



# FCC RF Test Report

APPLICANT : Motorola, Inc.  
EQUIPMENT : Enterprise Digital Assistant (EDA)  
BRAND NAME : Motorola  
MODEL NAME : MC659B  
FCC ID : UZ7MC659B  
STANDARD : FCC Part 15 Subpart C §15.247  
CLASSIFICATION : Digital Transmission System (DTS)

The product was received on Jan. 08, 2010 and completely tested on Jan. 22, 2010. We, SPORTON INTERNATIONAL INC., would like to declare that the tested sample has been evaluated in accordance with the procedures given in ANSI C63.4-2003 and shown the compliance with the applicable technical standards.

The test results in this report apply exclusively to the tested model / sample. Without written approval of SPORTON INTERNATIONAL INC., the test report shall not be reproduced except in full.

Reviewed by:

Roy Wu / Manager



## SPORTON INTERNATIONAL INC.

No. 52, Hwa Ya 1<sup>st</sup> Rd., Hwa Ya Technology Park, Kwei-Shan Hsiang, Tao Yuan Hsien, Taiwan, R.O.C.



# TABLE OF CONTENTS

REVISION HISTORY ..... 3

SUMMARY OF TEST RESULT ..... 4

1 GENERAL DESCRIPTION ..... 5

    1.1 Applicant ..... 5

    1.2 Manufacturer ..... 5

    1.3 Feature of Equipment Under Test ..... 5

    1.4 Testing Site ..... 6

    1.5 Applied Standards ..... 6

    1.6 Ancillary Equipment List ..... 7

2 TEST CONFIGURATION OF EQUIPMENT UNDER TEST ..... 8

    2.1 RF Power ..... 8

    2.2 Test Mode ..... 9

    2.3 Connection Diagram of Test System ..... 11

    2.4 RF Utility ..... 12

3 TEST RESULT ..... 13

    3.1 6dB and 99% Bandwidth Measurement ..... 13

    3.2 Output Power Measurement ..... 26

    3.3 Band Edges Measurement ..... 28

    3.4 Spurious Emission Measurement ..... 39

    3.5 Power Spectral Density Measurement ..... 49

    3.6 AC Conducted Emission Measurement ..... 56

    3.7 Radiated Emission Measurement ..... 64

    3.8 Antenna Requirements ..... 101

4 LIST OF MEASURING EQUIPMENT ..... 102

5 UNCERTAINTY OF EVALUATION ..... 103

APPENDIX A. PHOTOGRAPHS OF EUT

APPENDIX B. SETUP PHOTOGRAPHS



### REVISION HISTORY

REPORT NO.	VERSION	DESCRIPTION	ISSUED DATE
FR010801B	Rev. 01	Initial issue of report	Feb. 22, 2010

**SUMMARY OF TEST RESULT**

Report Section	FCC Rule	IC Rule	Description	Limit	Result	Remark
3.1	15.247(a)(2)	A8.2(a)	6dB Bandwidth	$\geq 0.5\text{MHz}$	Pass	-
3.1	-	Gen 4.4.1	99% Bandwidth	-	Pass	-
3.2	15.247(b)	A8.4	Output Power Measurement	$\leq 30\text{dBm}$	Pass	-
3.3	15.247(d)	A8.5	Frequency Band Edges	$\leq 20\text{dBc}$	Pass	-
3.4	15.247(d)	A8.5	Spurious Emission	$< 20\text{ dBc}$	Pass	-
3.5	15.247(e)	A8.2(b)	Power Spectral Density	$\leq 8\text{dBm}$	Pass	-
3.6	15.207	Gen 7.2.2	AC Conducted Emission	15.207(a)	Pass	Under limit 13.7 dB at 0.454 MHz
3.7	15.247(d)	A8.5	Transmitter Radiated Emission	15.209(a) & 15.247(d)	Pass	Under limit 6.10 dB at 2483.66 MHz
3.8	15.203 & 15.247(b)	A8.4	Antenna Requirement	N/A	Pass	-

# 1 General Description

## 1.1 Applicant

Motorola, Inc.

One Motorola Plaza, Holtsville, NY 11742-1300 USA

## 1.2 Manufacturer

Askey Technology (Jiangsu)

No. 1388, Jiao Tong Road, WuJiang Economic-Technological Development Area, Jiangsu Province  
215200, P. R. C.

## 1.3 Feature of Equipment Under Test

Product Feature & Specification	
Equipment	Enterprise Digital Assistant (EDA)
Brand Name	Motorola
Model Name	MC659B
FCC ID	UZ7MC659B
Tx/Rx Frequency Range	802.11b/g : 2400 MHz ~ 2483.5 MHz 802.11a : 5725 MHz ~ 5850 MHz
Channel Spacing	802.11b/g : 5 MHz 802.11a : 20 MHz
Maximum Output Power to Antenna	802.11b : 16.82 dBm (48.08 mW) 802.11g : 21.67 dBm (146.89 mW) 802.11a : 19.87 dBm (97.05 mW)
Antenna Type	802.11b/g : PIFA Antenna 802.11a : PIFA Antenna
Antenna Gain	802.11b/g : 2.17 dBi (1.67 + 0.5 dB trace loss) 802.11a : 3.70 dBi (2.70 + 1.0 dB trace loss)
HW Version	EVT2
SW Version	BSP2410
Type of Modulation	802.11b : DSSS (BPSK / QPSK / CCK) 802.11g/a : OFDM (BPSK / QPSK / 16QAM / 64QAM)
EUT Stage	Identical Prototype

**Remark:**

1. For other wireless features of this EUT, test report will be issued separately.
2. This test report recorded only product characteristics and test results of Digital Transmission System (DTS).
3. The above EUT's information was declared by manufacturer. Please refer to the specifications or user's manual for more detailed description.

## 1.4 Testing Site

<b>Test Site</b>	SPORTON INTERNATIONAL INC.		
<b>Test Site Location</b>	No. 52, Hwa Ya 1 <sup>st</sup> Rd., Hwa Ya Technology Park, Kwei-Shan Hsiang, Tao Yuan Hsien, Taiwan, R.O.C. TEL: +886-3-3273456 / FAX: +886-3-3284978		
<b>Test Site No.</b>	<b>Sporton Site No.</b>		<b>FCC/IC Registration No.</b>
	CO05-HY	03CH07HY	TW1022/4086B-1

## 1.5 Applied Standards

According to the specifications of the manufacturer, the EUT must comply with the requirements of the following standards:

- ♦ FCC Part 15 Subpart C §15.247
- ♦ FCC KDB Publication No. 558074 (Measurement Guidelines of DTS)
- ♦ ANSI C63.4-2003
- ♦ IC RSS-210 Issue 7 Annex 8

**Remark:**

1. All test items were verified and recorded according to the standards and without any deviation during the test.
2. This EUT has also been tested and complied with the requirements of FCC Part 15, Subpart B (DoC), recorded in a separate test report.



### 1.6 Ancillary Equipment List

Item	Equipment	Trade Name	Model Name	FCC ID	Data Cable	Power Cord
1.	System Simulator	R&S	CMU 200	N/A	N/A	Unshielded, 1.8 m
2.	GPS Station	T&E	GS-50	N/A	N/A	Unshielded, 1.8 m
3.	WLAN AP	D-Link	DIR-628	KA2DIR628A2	N/A	Unshielded, 1.8 m
4.	Notebook	DELL	Vostro 1510	FCC DoC	N/A	AC I/P: Unshielded, 1.2 m DC O/P: Shielded, 1.8 m
5.	LCD Monitor	Lenovo	6135-AB1	FCC DoC	Shielded, 1.6 m	Unshielded, 1.8 m
6.	LCD Monitor	Dell	U2410	FCC DoC	Shielded, 1.6 m	Unshielded, 1.8 m
7.	Bluetooth Earphone	Nokia	BH-102	PYAHS-107W	N/A	N/A
8.	iPod	Apple	A1285	FCC DoC	Shielded, 1.0 m	N/A
9.	iPod	Apple	A1199	FCC DoC	Shielded, 1.0 m	N/A

## 2 Test Configuration of Equipment Under Test

### 2.1 RF Power

Preliminary tests were performed in different data rate and recorded the RF Output Power in the following table:

Channel	Frequency	2.4GHz 802.11b RF Power (dBm)			
		At DSSS Data Rate			
		1 Mbps	2 Mbps	5.5 Mbps	11 Mbps
CH 01	2412 MHz	16.38	16.38	16.31	16.37
CH 06	2437 MHz	16.23	16.17	16.13	16.19
CH 11	2462 MHz	<b>16.82</b>	16.77	16.74	16.72
CH 12	2467 MHz	10.96	10.91	10.96	10.98
CH 13	2472 MHz	4.56	4.55	4.45	4.54

Channel	Frequency	2.4GHz 802.11g RF Power (dBm)							
		At OFDM Data Rate							
		6 Mbps	9 Mbps	12 Mbps	18 Mbps	24 Mbps	36 Mbps	48 Mbps	54 Mbps
CH 01	2412 MHz	20.30	20.28	20.71	20.14	20.50	20.45	20.25	20.36
CH 02	2417 MHz	20.58	20.38	20.93	20.41	20.72	20.58	20.57	20.10
CH 06	2437 MHz	<b>21.67</b>	21.43	21.65	21.45	21.66	21.33	21.04	20.57
CH 10	2457 MHz	21.01	20.73	21.14	20.62	21.09	20.93	21.05	20.60
CH 11	2462 MHz	20.12	19.85	20.15	19.80	20.45	20.04	19.65	20.24
CH 12	2467 MHz	14.90	14.06	14.99	14.03	14.44	14.13	14.15	14.39
CH 13	2472 MHz	-16.66	-15.71	-16.61	-16.40	-16.17	-16.50	-16.40	-16.41

Channel	Frequency	5GHz 802.11a RF Power (dBm)							
		At OFDM Data Rate							
		6 Mbps	9 Mbps	12 Mbps	18 Mbps	24 Mbps	36 Mbps	48 Mbps	54 Mbps
CH149	5745 MHz	<b>19.87</b>	19.80	19.86	19.74	19.79	19.21	19.00	18.69
CH157	5785 MHz	19.43	19.28	19.41	19.35	19.36	18.69	18.50	18.35
CH165	5825 MHz	18.99	18.86	18.92	18.95	19.04	18.50	18.16	17.98

**Remark:**

1. The data rates of WLAN 802.11a/b/g were set in 1Mbps for 802.11b and 6Mbps for 802.11g/a for all the test cases due to the highest RF output power.
2. The EUT is programmed to transmit signal continuously for all testing.





## 2.2 Test Mode

The EUT has been associated with peripherals pursuant to ANSI C63.4-2003 and configuration operated in a manner tended to maximize its emission characteristics in a typical application. Frequency range investigated: conducted emission (150 kHz to 30 MHz), radiated emission (30 MHz to the 10th harmonic of the highest fundamental frequency or to 40 GHz, whichever is lower).

Pre-scanned tests were conducted to determine the final configuration from all possible combinations.

The following tables are showing the test modes as the worst cases and recorded in this report.

Test Cases			
Test Item	802.11b (Modulation : DSSS)	802.11g (Modulation : OFDM)	802.11a Band III (Modulation : OFDM)
Conducted TCs	Mode 1: 802.11b_CH01_ 2412 MHz	Mode 4: 802.11g_CH01_ 2412 MHz	Mode 7: 802.11a_CH149_ 5745 MHz
	Mode 2: 802.11b_CH06_ 2437 MHz	Mode 5: 802.11g_CH06_ 2437 MHz	Mode 8: 802.11a_CH157_ 5785 MHz
	Mode 3: 802.11b_CH11_ 2462 MHz	Mode 6: 802.11g_CH11_ 2462 MHz	Mode 9: 802.11a_CH165_ 5825 MHz



Test Cases			
<b>Radiated TCs</b>	Mode 1: 802.11b_CH01_ 2412 MHz + Qwerty Keypad	Mode 6: 802.11g_CH01_ 2412 MHz + Qwerty Keypad	Mode 14: 802.11a_CH149 _5745 MHz + Qwerty Keypad
	Mode 2: 802.11b_CH06_ 2437 MHz + Qwerty Keypad	Mode 7: 802.11g_CH02_ 2417 MHz + Qwerty Keypad	Mode 15: 802.11a_CH157 _5785 MHz + Qwerty Keypad
	Mode 3: 802.11b_CH11_ 2462 MHz + Qwerty Keypad	Mode 8: 802.11g_CH06_ 2437 MHz + Qwerty Keypad	Mode 16: 802.11a_CH165 _5825 MHz + Qwerty Keypad
	Mode 4: 802.11b_CH12_ 2467 MHz + Qwerty Keypad	Mode 9: 802.11g_CH10_ 2457 MHz + Qwerty Keypad	Mode 17: 802.11a_CH165 _5825 MHz + Numeric Keypad
	Mode 5: 802.11b_CH13_ 2472 MHz + Qwerty Keypad	Mode 10: 802.11g_CH11_ 2462 MHz + Qwerty Keypad	
		Mode 11: 802.11g_CH12_ 2467 MHz + Qwerty Keypad	
		Mode 12: 802.11g_CH13_ 2472 MHz + Qwerty Keypad	
		Mode 13: 802.11g_CH11_ 2462 MHz + Numeric Keypad	
	<b>AC Conducted Emission</b>	Mode 1 : GSM 850 Idle + WLAN Link (2.4G) + Bluetooth Link + GPS Rx + USB Charging Cable with AC Power + USB Link + Camera + MP3 + Qwerty Keypad Mode 2 : WCDMA Band V Idle + WLAN Link (2.4G) + Bluetooth Link + GPS Rx + USB Charging Cable with AC Power + USB Link + Scanner + MP3 + Qwerty Keypad Mode 3 : CDMA2000 BC0 Idle + WLAN Link (2.4G) + Bluetooth Link + GPS Rx + USB Charging Cable with AC Power + USB Link + Camera + MP3 + Numeric Keypad	

**Remark:**

1. For radiated TCs test was performed together with USB charging cable with AC power.
2. The Mode 4, Mode 5, Mode 7, Mode 9, Mode 11, and Mode 12 of radiation test only performed Band Edges.
3. "Bluetooth Link" stands for terminal linked to headset by Bluetooth function.
4. "WLAN Link" stands for terminal associated with AP at 2.4GHz band.
5. "GPS Rx" stands for receive signals from GPS station continuously.
6. "Scanner" stands for scanning and decoding a barcode by scanner.
7. "MP3" stands for playing MP3 file.
8. "Camera" stands for playing camera to capture picture.
9. "USB Link" stands for active sync file transfer.

## 2.3 Connection Diagram of Test System

<Radiation Test>

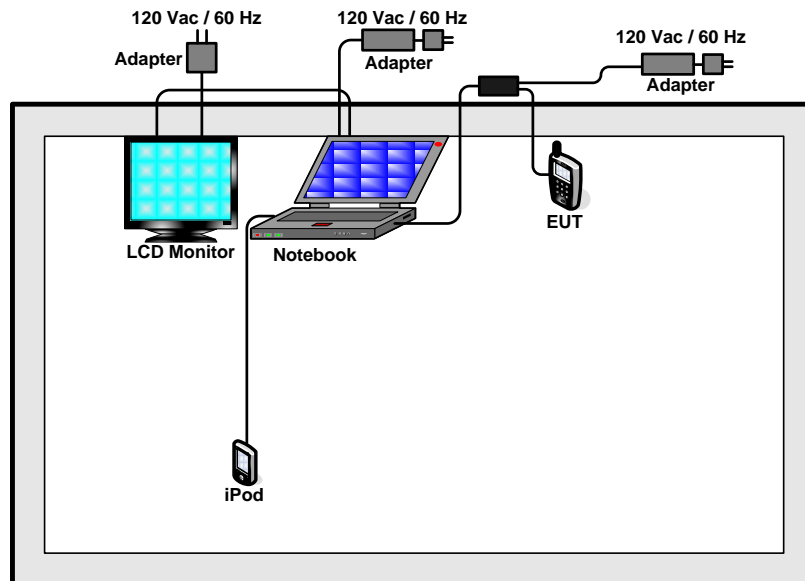

<Conduction Test>

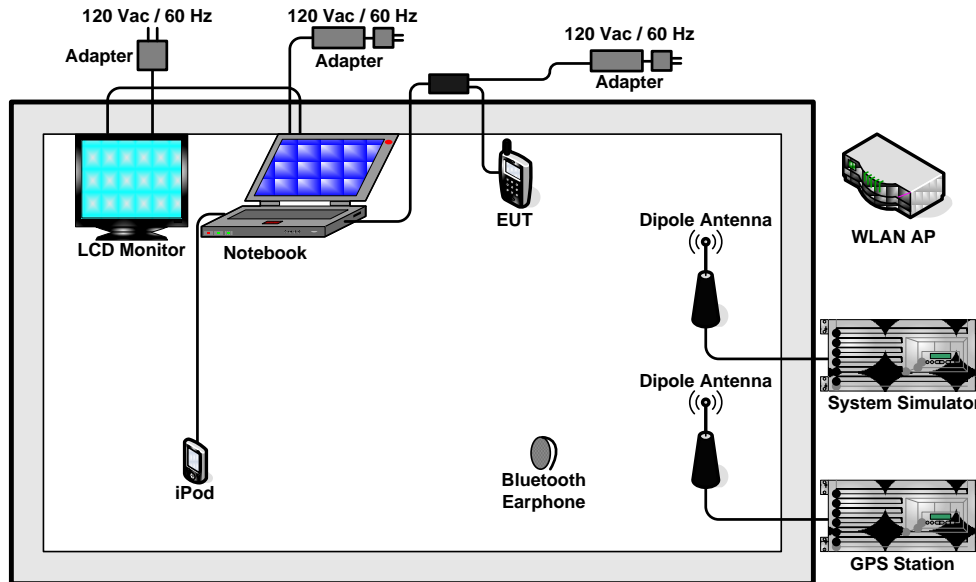

## 2.4 RF Utility

The programmed RF utility "Fcc test2009" is installed in EUT to provide channel selection, power level, data rate and the application type. RF Utility can send transmitting signal for all testing. The RF output power selection is for the setting of RF output power expected by the customer and is going to be fixed on the firmware of the final end product.

### 3 Test Result

#### 3.1 6dB and 99% Bandwidth Measurement

##### 3.1.1 Limit of 6dB Bandwidth

The minimum 6 dB bandwidth shall be at least 500 kHz.

##### 3.1.2 Measuring Instruments

See list of measuring instruments of this test report.

##### 3.1.3 Test Procedures

1. The testing follows FCC KDB Publication No. 558074 (Measurement Guidelines of DTS).
2. The RF output of EUT was connected to the spectrum analyzer by a low loss cable.
3. Make the measurement with the spectrum analyzer's resolution bandwidth (RBW) = 100 kHz. In order to make an accurate measurement, set the span greater than RBW. The 6 dB bandwidth must be greater than 500 kHz.
4. The marker-delta reading at this point is the 6 dB bandwidth of the emission.

##### 3.1.4 Test Setup

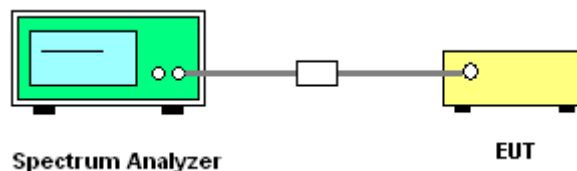



3.1.5 Test Result of 6dB Bandwidth

Test Mode :	Mode 1, 2, 3	Temperature :	24~26°C
Test Engineer :	Ken Hsu	Relative Humidity :	37~40%

Channel	Frequency (MHz)	802.11b 6dB Bandwidth (MHz)	6dB Bandwidth Min. Limit (MHz)	Pass/Fail
01	2412	13.04	0.5	Pass
06	2437	13.04	0.5	Pass
11	2462	13.08	0.5	Pass

Mode 1 : 6 dB Bandwidth Plot on 802.11b Channel 01

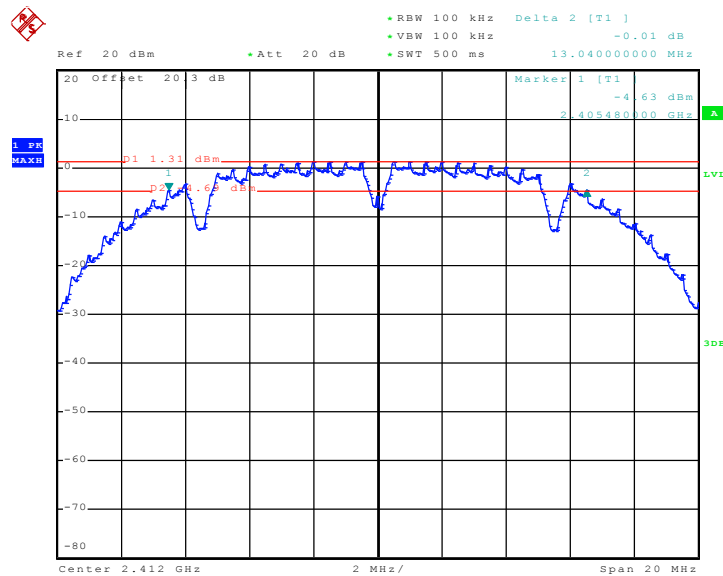

Date: 24.JAN.2010 04:06:27



Mode 2 : 6 dB Bandwidth Plot on 802.11b Channel 06

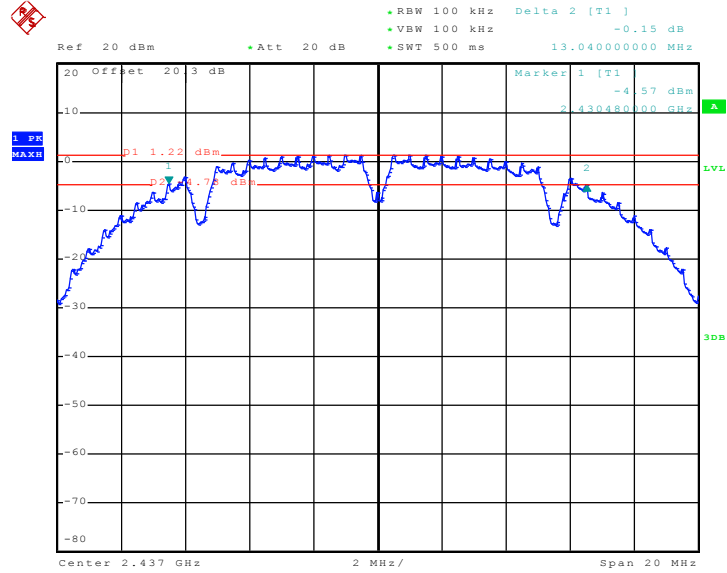

Date: 24.JAN.2010 04:09:30

Mode 3 : 6 dB Bandwidth Plot on 802.11b Channel 11

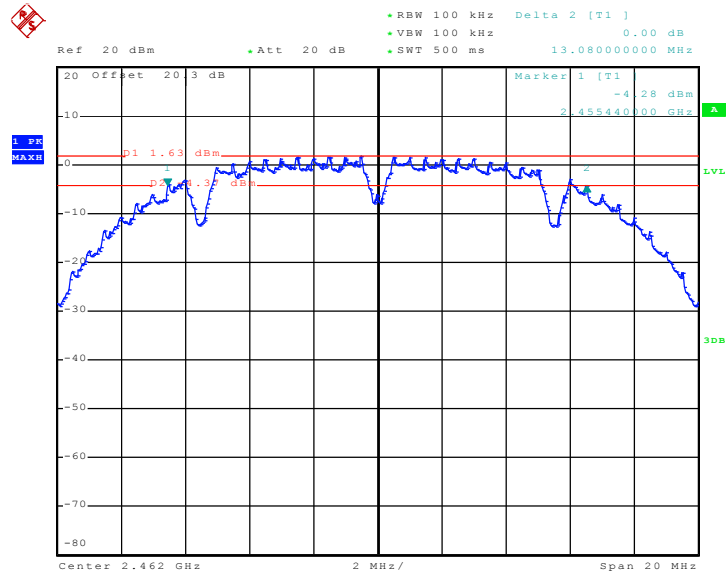

Date: 24.JAN.2010 04:07:36



Test Mode :	Mode 4, 5, 6	Temperature :	24~26°C
Test Engineer :	Ken Hsu	Relative Humidity :	37~40%

Channel	Frequency (MHz)	802.11g 6dB Bandwidth (MHz)	6dB Bandwidth Min. Limit (MHz)	Pass/Fail
01	2412	16.36	0.5	Pass
06	2437	16.36	0.5	Pass
11	2462	16.36	0.5	Pass

Mode 4 : 6 dB Bandwidth Plot on 802.11g Channel 01

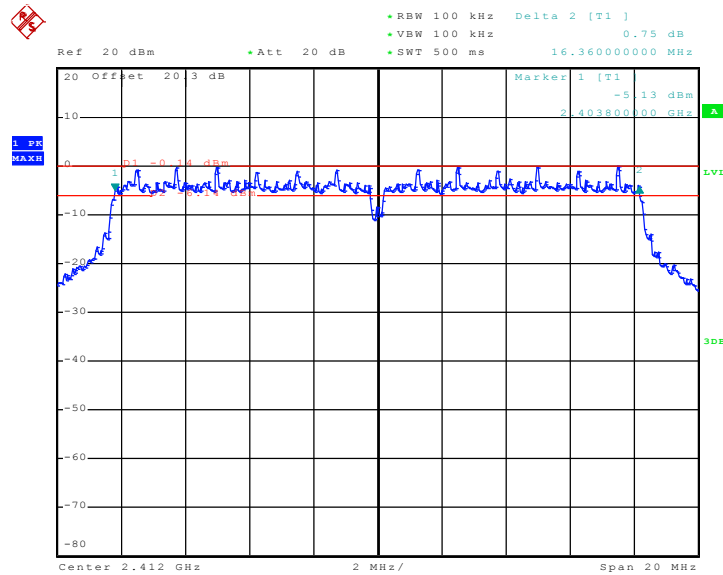

Date: 24..JAN..2010 03:59:46





Mode 5 : 6 dB Bandwidth Plot on 802.11g Channel 06

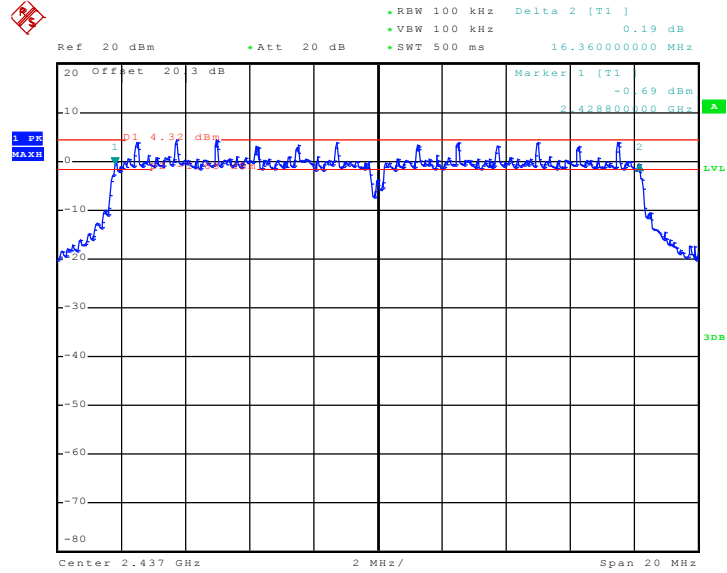

Date: 24.JAN.2010 04:02:24

Mode 6 : 6 dB Bandwidth Plot on 802.11g Channel 11

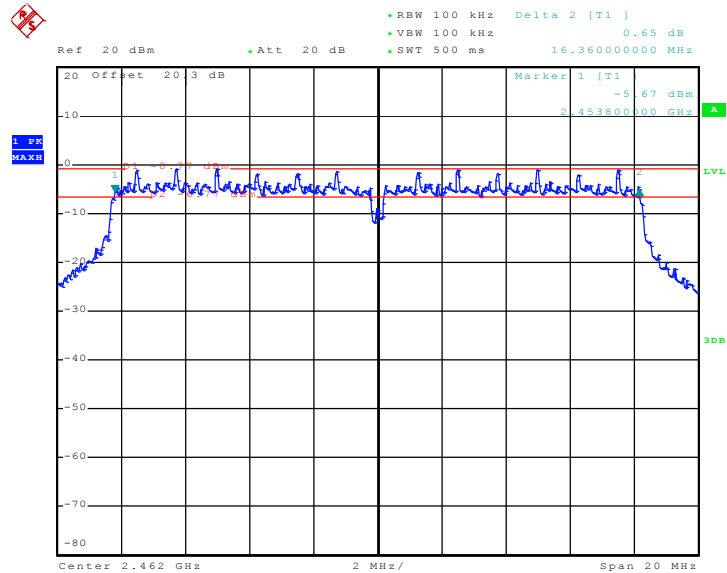

Date: 24.JAN.2010 04:00:59



Test Mode :	Mode 7, 8, 9	Temperature :	24~26°C
Test Engineer :	Ken Hsu	Relative Humidity :	37~40%

Channel	Frequency (MHz)	802.11a 6dB Bandwidth (MHz)	6dB Bandwidth Min. Limit (MHz)	Pass/Fail
149	5745	16.36	0.5	Pass
157	5785	16.36	0.5	Pass
165	5825	16.36	0.5	Pass

Mode 7: 6 dB Bandwidth Plot on 802.11a Channel 149

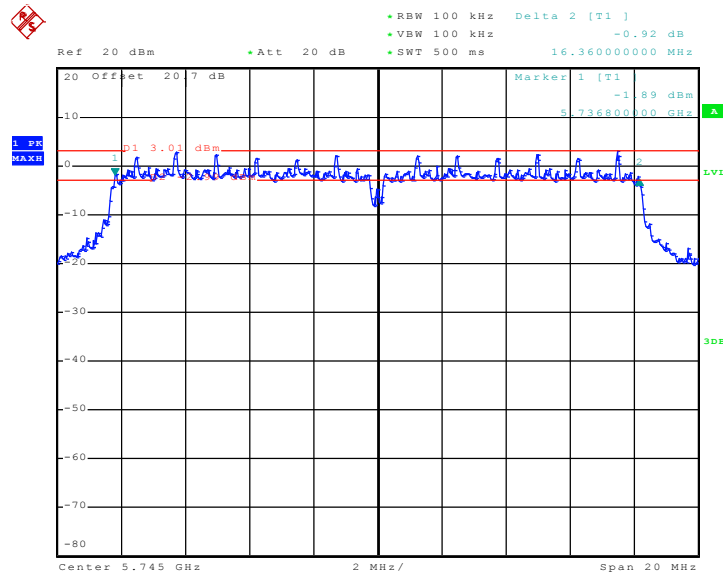

Date: 24..JAN.2010 04:58:43



Mode 8: 6 dB Bandwidth Plot on 802.11a Channel 157

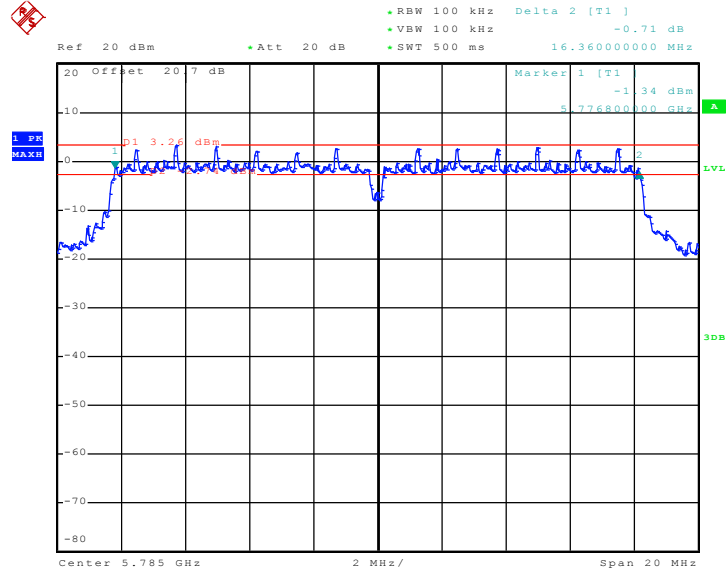

Date: 24.JAN.2010 04:57:48

Mode 9: 6 dB Bandwidth Plot on 802.11a Channel 165

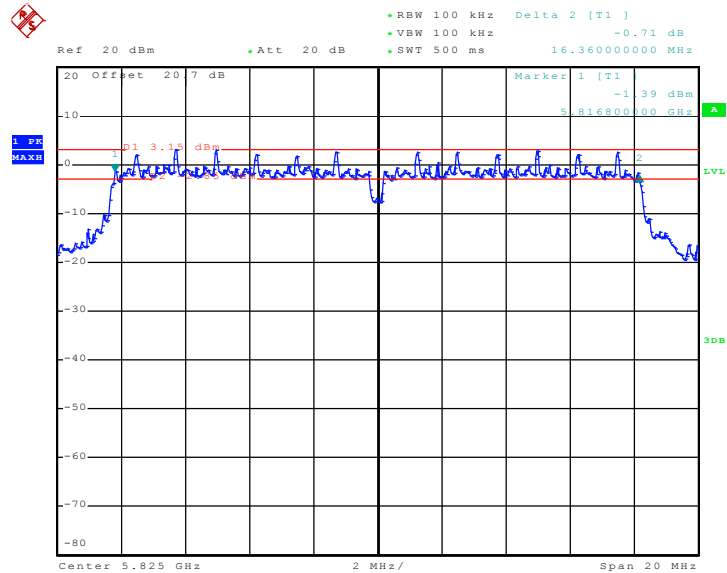

Date: 24.JAN.2010 04:56:45



3.1.6 Test Result of 99% Occupied Bandwidth

Test Mode :	Mode 1, 2, 3	Temperature :	24~26°C
Test Engineer :	Ken Hsu	Relative Humidity :	37~40%

Channel	Frequency (MHz)	802.11b 99% Occupied Bandwidth (MHz)	Pass/Fail
01	2412	15.80	Pass
06	2437	15.80	Pass
11	2462	15.72	Pass

Mode 1 : 99% Occupied Bandwidth Plot on 802.11b Channel 01

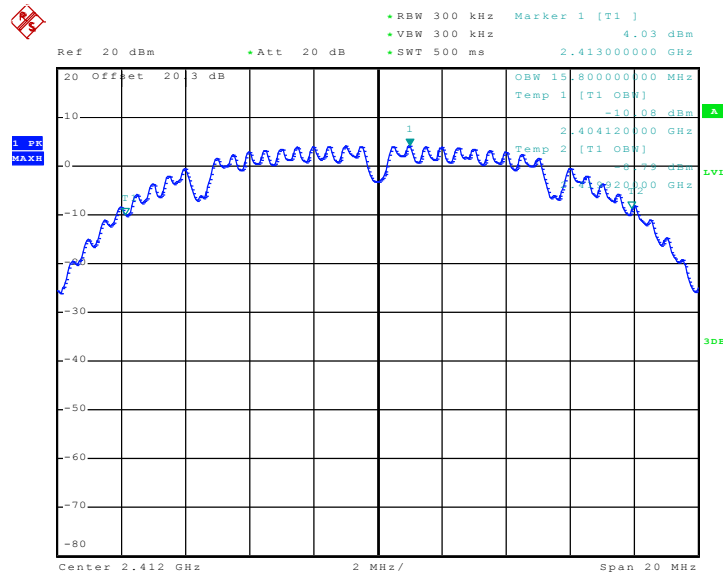

Date: 24.JAN.2010 04:24:13



Mode 2 : 99% Occupied Bandwidth Plot on 802.11b Channel 06

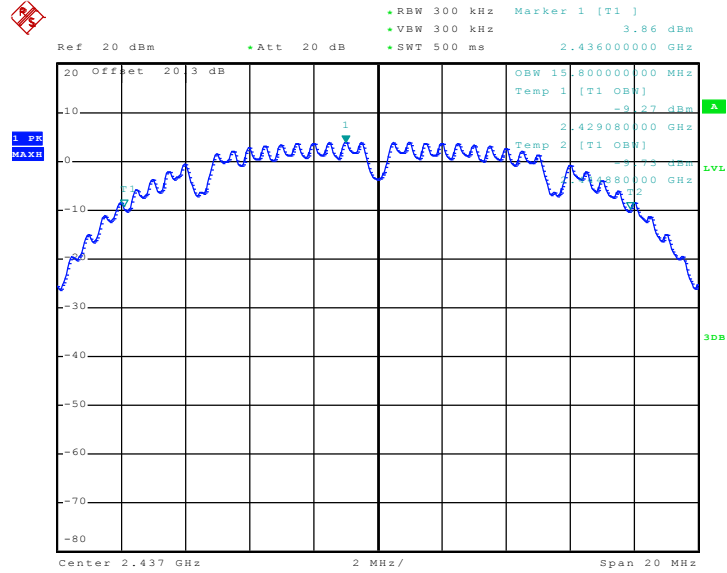

Date: 24.JAN.2010 04:24:39

Mode 3 : 99% Occupied Bandwidth Plot on 802.11b Channel 11

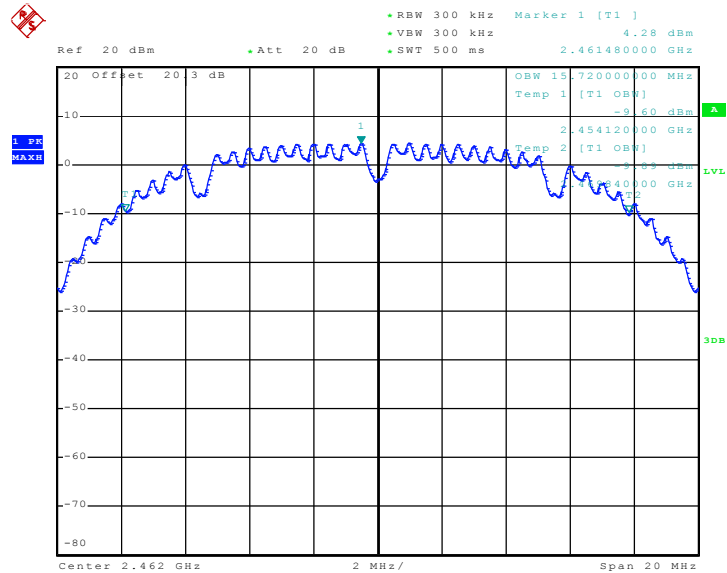

Date: 24.JAN.2010 04:24:58



Test Mode :	Mode 4, 5, 6	Temperature :	24~26°C
Test Engineer :	Ken Hsu	Relative Humidity :	37~40%

Channel	Frequency (MHz)	802.11g 99% Occupied Bandwidth (MHz)	Pass/Fail
01	2412	16.88	Pass
06	2437	16.88	Pass
11	2462	16.88	Pass

Mode 4 : 99% Occupied Bandwidth Plot on 802.11g Channel 01

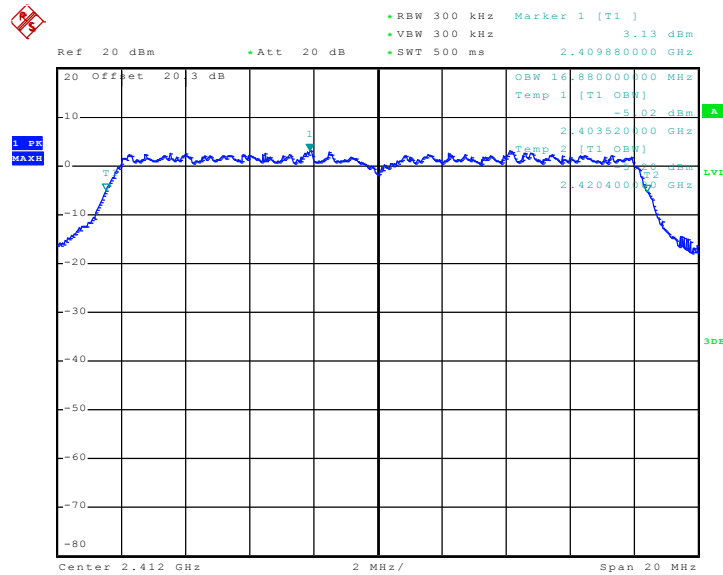

Date: 24..JAN..2010 04:26:57



Mode 5 : 99% Occupied Bandwidth Plot on 802.11g Channel 06

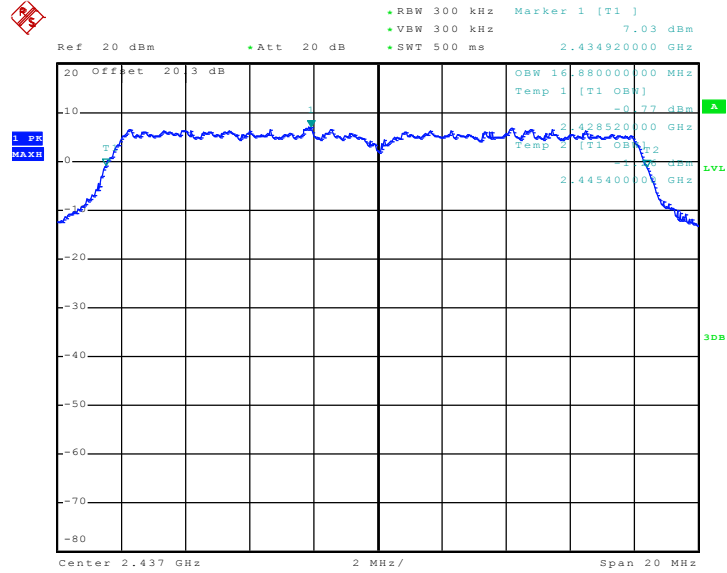

Date: 24.JAN.2010 04:26:25

Mode 6 : 99% Occupied Bandwidth Plot on 802.11g Channel 11

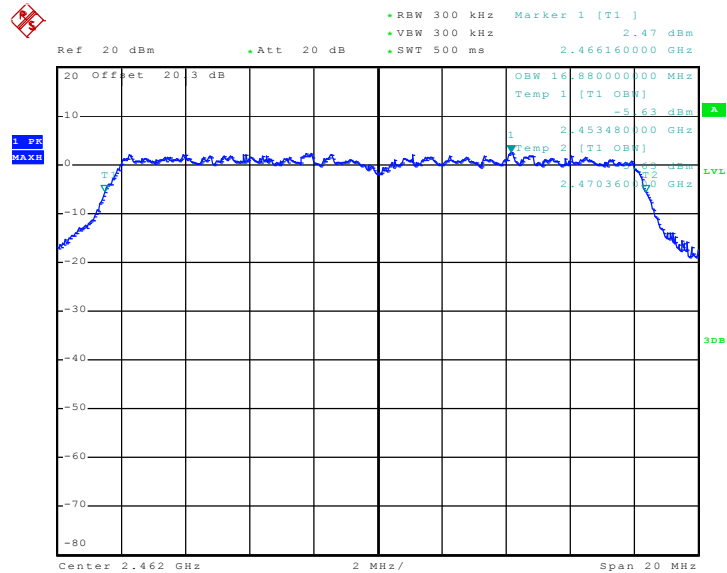

Date: 24.JAN.2010 04:25:55



Test Mode :	Mode 7, 8, 9	Temperature :	24~26°C
Test Engineer :	Ken Hsu	Relative Humidity :	37~40%

Channel	Frequency (MHz)	802.11a 99% Occupied Bandwidth (MHz)	Pass/Fail
149	5745	16.92	Pass
157	5785	16.96	Pass
165	5825	16.96	Pass

Mode 7: 99% Occupied Bandwidth Plot on 802.11a Channel 149

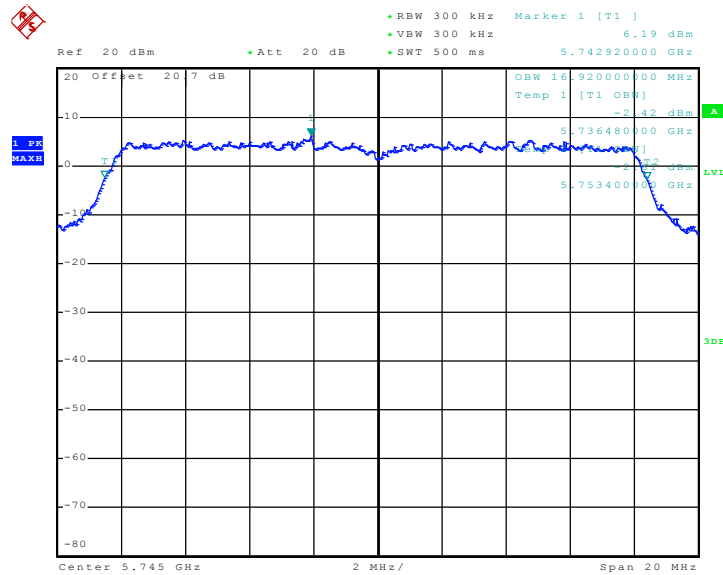

Date: 24 JAN. 2010 04:53:55





Mode 8: 99% Occupied Bandwidth Plot on 802.11a Channel 157

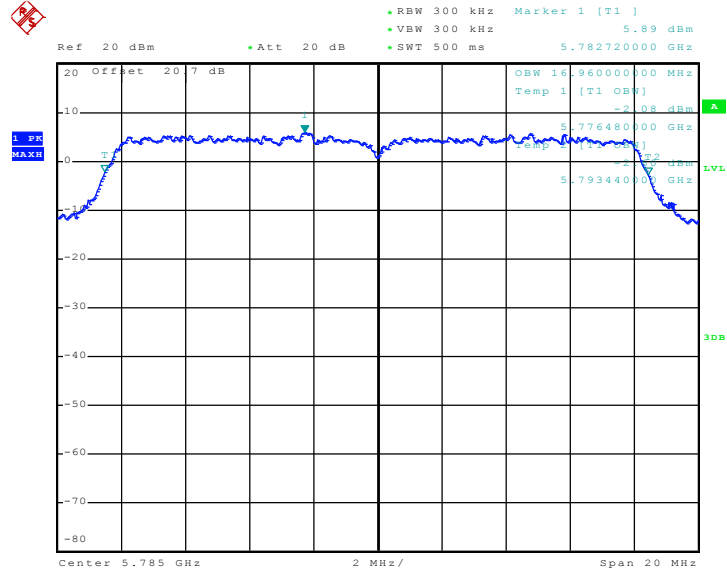

Date: 24.JAN.2010 04:54:47

Mode 9: 99% Occupied Bandwidth Plot on 802.11a Channel 165

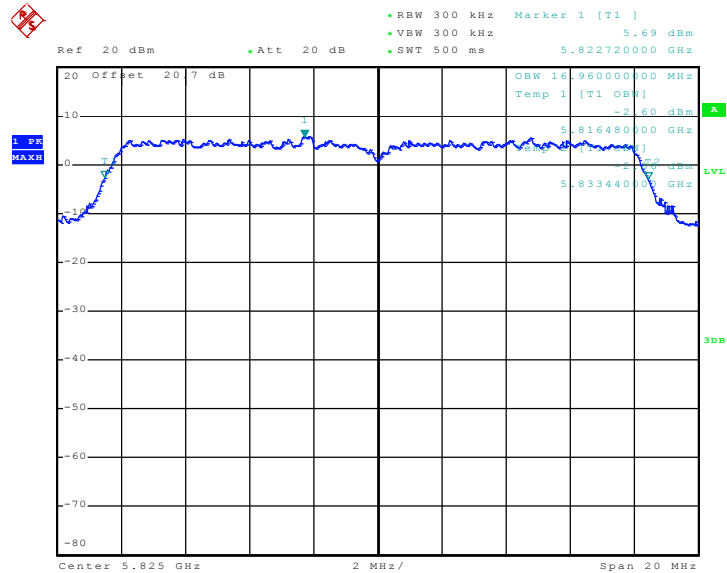

Date: 24.JAN.2010 04:55:16

## 3.2 Output Power Measurement

### 3.2.1 Limit of Output Power

For systems using digital modulation in the 2400-2483.5MHz and 5725-5850MHz, the limit for peak output power is 30dBm. If transmitting antenna of directional gain greater than 6dBi are used the peak output power from the intentional radiator shall be reduced below the above stated value by the amount in dB that the directional gain of the antenna exceeds 6 dBi. In case of point-to-point operation, the limit has to be reduced by 1dB for every 3dB that the directional gain of the antenna exceeds 6dBi.

### 3.2.2 Measuring Instruments

See list of measuring instruments of this test report.

### 3.2.3 Test Procedures

1. The testing follows FCC KDB Publication No. 558074 (Measurement Guidelines of DTS).
2. The RF output of EUT was connected to the power meter by a low loss cable.
3. Measure the power by power meter.

### 3.2.4 Test Setup

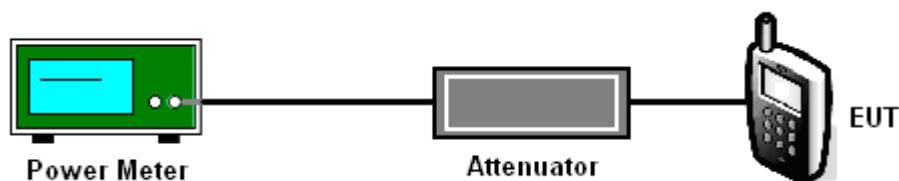

**3.2.5 Test Result of Output Power**

<b>Test Mode :</b>	Mode 1, 2, 3	<b>Temperature :</b>	24~26°C
<b>Test Engineer :</b>	Ken Hsu	<b>Relative Humidity :</b>	37~40%

Channel	Frequency (MHz)	802.11b Measured Output Power (dBm)	Max. Limits (dBm)	Pass/Fail
01	2412	16.38	30	Pass
06	2437	16.23	30	Pass
11	2462	16.82	30	Pass
13	2472	4.56	30	Pass

<b>Test Mode :</b>	Mode 4, 5, 6	<b>Temperature :</b>	24~26°C
<b>Test Engineer :</b>	Ken Hsu	<b>Relative Humidity :</b>	37~40%

Channel	Frequency (MHz)	802.11g Measured Output Power (dBm)	Max. Limits (dBm)	Pass/Fail
01	2412	20.30	30	Pass
06	2437	21.67	30	Pass
11	2462	20.12	30	Pass
13	2472	-16.66	30	Pass

<b>Test Mode :</b>	Mode 7, 8, 9	<b>Temperature :</b>	24~26°C
<b>Test Engineer :</b>	Ken Hsu	<b>Relative Humidity :</b>	37~40%

Channel	Frequency (MHz)	802.11a Measured Output Power (dBm)	Max. Limits (dBm)	Pass/Fail
149	5745	19.87	30	Pass
157	5785	19.43	30	Pass
165	5825	18.99	30	Pass



### **3.3 Band Edges Measurement**

#### **3.3.1 Limit of Band Edges**

In any 100 kHz bandwidth outside the intentional radiation frequency band, the radio frequency power shall be at least 20 dB below the highest level of the radiated power. If the output power of this device was measured by spectrum analyzer, the attenuation under this paragraph shall be 30 dB instead of 20 dB.

#### **3.3.2 Measuring Instruments**

See list of measuring instruments of this test report.

#### **3.3.3 Test Procedures**

1. The testing follows the guidelines in ANSI C63.4-2003 and FCC KDB Publication No. 558074 (Measurement Guidelines of DTS).
2. Conducted emission test: Set RBW = 100 kHz, Video bandwidth (VBW) > RBW. Band edge emissions must be at least 20 dB below the highest emission level within the authorized band as measured with a 100 kHz RBW. Note: If the output power of this device was measured by power meter, the attenuation under this paragraph shall be 30 dB instead of 20 dB.
3. Radiated emission test: Apply to band edge emissions that fall in the restricted bands listed in FCC Section 15.205. The maximum permitted average field strength is listed in FCC Section 15.209. A pre-amp is necessary for this measurement. For measurements above 1 GHz, set RBW = 1MHz, VBW = 10 Hz, Sweep=Auto. If the emission is pulsed, modify the unit for continuous operation; use the settings shown above, then correct the reading by subtracting the peak-average correction factor, derived from the appropriate duty cycle calculation as in FCC Section 15.35(b) and (c).

### 3.3.4 Test Setup

#### <Radiated Band Edges>

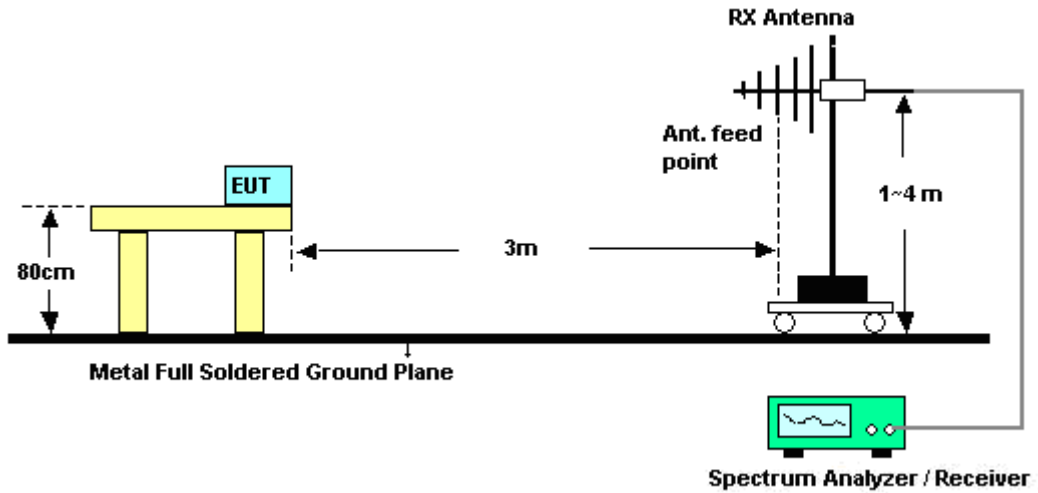

#### <Conducted Band Edges>

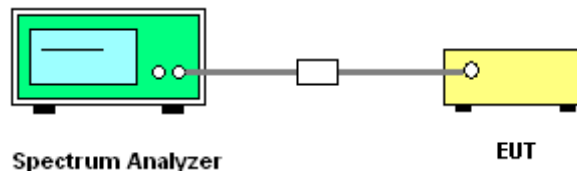



3.3.5 Test Result of Radiated Band Edges

Test Mode :	Mode 1	Temperature :	22~23°C
Test Band :	802.11b	Relative Humidity :	42~43%
Test Channel :	01	Test Engineer :	Kay Wu

ANTENNA POLARITY : HORIZONTAL										
Frequency ( MHz )	Level ( dBuV/m )	Over Limit ( dB )	Limit Line ( dBuV/m )	Read Level ( dBuV )	Antenna Factor ( dB )	Cable Loss ( dB )	Preamp Factor ( dB )	Ant Pos ( cm )	Table Pos ( deg )	Remark
2385.81	49.92	-24.08	74	46.48	32.13	5.46	34.15	100	7	Peak
2385.81	39.62	-14.38	54	36.18	32.13	5.46	34.15	100	7	Average

ANTENNA POLARITY : VERTICAL										
Frequency ( MHz )	Level ( dBuV/m )	Over Limit ( dB )	Limit Line ( dBuV/m )	Read Level ( dBuV )	Antenna Factor ( dB )	Cable Loss ( dB )	Preamp Factor ( dB )	Ant Pos ( cm )	Table Pos ( deg )	Remark
2386.38	51.39	-22.61	74	47.95	32.13	5.46	34.15	153	115	Peak
2386.38	41.16	-12.84	54	37.72	32.13	5.46	34.15	153	115	Average

Test Mode :	Mode 3	Temperature :	22~23°C
Test Band :	802.11b	Relative Humidity :	42~43%
Test Channel :	11	Test Engineer :	Kay Wu

ANTENNA POLARITY : HORIZONTAL										
Frequency ( MHz )	Level ( dBuV/m )	Over Limit ( dB )	Limit Line ( dBuV/m )	Read Level ( dBuV )	Antenna Factor ( dB )	Cable Loss ( dB )	Preamp Factor ( dB )	Ant Pos ( cm )	Table Pos ( deg )	Remark
2488.22	57.84	-16.16	74	54.36	32.3	5.37	34.19	101	48	Peak
2488.22	47.71	-6.29	54	44.23	32.3	5.37	34.19	101	48	Average

ANTENNA POLARITY : VERTICAL										
Frequency ( MHz )	Level ( dBuV/m )	Over Limit ( dB )	Limit Line ( dBuV/m )	Read Level ( dBuV )	Antenna Factor ( dB )	Cable Loss ( dB )	Preamp Factor ( dB )	Ant Pos ( cm )	Table Pos ( deg )	Remark
2488.22	56.4	-17.6	74	52.92	32.3	5.37	34.19	120	104	Peak
2488.22	46.98	-7.02	54	43.5	32.3	5.37	34.19	120	104	Average



Test Mode :	Mode 4	Temperature :	22~23°C
Test Band :	802.11b	Relative Humidity :	42~43%
Test Channel :	12	Test Engineer :	Kay Wu

ANTENNA POLARITY : HORIZONTAL										
Frequency ( MHz )	Level ( dBuV/m )	Over Limit ( dB )	Limit Line ( dBuV/m )	Read Level ( dBuV )	Antenna Factor ( dB )	Cable Loss ( dB )	Preamp Factor ( dB )	Ant Pos ( cm )	Table Pos ( deg )	Remark
2483.5	57.43	-16.57	74	53.97	32.27	5.38	34.19	101	47	Peak
2483.5	47.39	-6.61	54	43.93	32.27	5.38	34.19	101	47	Average

ANTENNA POLARITY : VERTICAL										
Frequency ( MHz )	Level ( dBuV/m )	Over Limit ( dB )	Limit Line ( dBuV/m )	Read Level ( dBuV )	Antenna Factor ( dB )	Cable Loss ( dB )	Preamp Factor ( dB )	Ant Pos ( cm )	Table Pos ( deg )	Remark
2483.66	55.26	-18.74	74	51.8	32.27	5.38	34.19	137	288	Peak
2483.66	46.32	-7.68	54	42.86	32.27	5.38	34.19	137	288	Average

Test Mode :	Mode 5	Temperature :	22~23°C
Test Band :	802.11b	Relative Humidity :	42~43%
Test Channel :	13	Test Engineer :	Kay Wu

ANTENNA POLARITY : HORIZONTAL										
Frequency ( MHz )	Level ( dBuV/m )	Over Limit ( dB )	Limit Line ( dBuV/m )	Read Level ( dBuV )	Antenna Factor ( dB )	Cable Loss ( dB )	Preamp Factor ( dB )	Ant Pos ( cm )	Table Pos ( deg )	Remark
2483.5	54.92	-19.08	74	51.46	32.27	5.38	34.19	100	54	Peak
2483.5	46.31	-7.69	54	42.85	32.27	5.38	34.19	100	54	Average

ANTENNA POLARITY : VERTICAL										
Frequency ( MHz )	Level ( dBuV/m )	Over Limit ( dB )	Limit Line ( dBuV/m )	Read Level ( dBuV )	Antenna Factor ( dB )	Cable Loss ( dB )	Preamp Factor ( dB )	Ant Pos ( cm )	Table Pos ( deg )	Remark
2483.5	54.65	-19.35	74	51.19	32.27	5.38	34.19	154	129	Peak
2483.5	45.8	-8.2	54	42.34	32.27	5.38	34.19	154	129	Average



Test Mode :	Mode 6	Temperature :	22~23°C
Test Band :	802.11g	Relative Humidity :	42~43%
Test Channel :	01	Test Engineer :	Kay Wu

ANTENNA POLARITY : HORIZONTAL										
Frequency ( MHz )	Level ( dBuV/m )	Over Limit ( dB )	Limit Line ( dBuV/m )	Read Level ( dBuV )	Antenna Factor ( dB )	Cable Loss ( dB )	Preamp Factor ( dB )	Ant Pos ( cm )	Table Pos ( deg )	Remark
2389.61	67.27	-6.73	74	63.83	32.13	5.46	34.15	100	57	Peak
2389.61	45.53	-8.47	54	42.09	32.13	5.46	34.15	100	57	Average

ANTENNA POLARITY : VERTICAL										
Frequency ( MHz )	Level ( dBuV/m )	Over Limit ( dB )	Limit Line ( dBuV/m )	Read Level ( dBuV )	Antenna Factor ( dB )	Cable Loss ( dB )	Preamp Factor ( dB )	Ant Pos ( cm )	Table Pos ( deg )	Remark
2389.61	59.86	-14.14	74	56.42	32.13	5.46	34.15	126	349	Peak
2389.61	40.06	-13.94	54	36.62	32.13	5.46	34.15	126	349	Average

Test Mode :	Mode 7	Temperature :	22~23°C
Test Band :	802.11g	Relative Humidity :	42~43%
Test Channel :	02	Test Engineer :	Kay Wu

ANTENNA POLARITY : HORIZONTAL										
Frequency ( MHz )	Level ( dBuV/m )	Over Limit ( dB )	Limit Line ( dBuV/m )	Read Level ( dBuV )	Antenna Factor ( dB )	Cable Loss ( dB )	Preamp Factor ( dB )	Ant Pos ( cm )	Table Pos ( deg )	Remark
2389.42	64.06	-9.94	74	60.62	32.13	5.46	34.15	100	54	Peak
2389.42	42.33	-11.67	54	38.89	32.13	5.46	34.15	100	54	Average

ANTENNA POLARITY : VERTICAL										
Frequency ( MHz )	Level ( dBuV/m )	Over Limit ( dB )	Limit Line ( dBuV/m )	Read Level ( dBuV )	Antenna Factor ( dB )	Cable Loss ( dB )	Preamp Factor ( dB )	Ant Pos ( cm )	Table Pos ( deg )	Remark
2389.99	60.98	-13.02	74	57.55	32.13	5.46	34.16	100	243	Peak
2389.99	40.3	-13.7	54	36.87	32.13	5.46	34.16	100	243	Average





Test Mode :	Mode 9	Temperature :	22~23°C
Test Band :	802.11g	Relative Humidity :	42~43%
Test Channel :	10	Test Engineer :	Kay Wu

ANTENNA POLARITY : HORIZONTAL										
Frequency ( MHz )	Level ( dBuV/m )	Over Limit ( dB )	Limit Line ( dBuV/m )	Read Level ( dBuV )	Antenna Factor ( dB )	Cable Loss ( dB )	Preamp Factor ( dB )	Ant Pos ( cm )	Table Pos ( deg )	Remark
2483.66	67.9	-6.1	74	64.44	32.27	5.38	34.19	123	63	Peak
2483.66	46.53	-7.47	54	43.07	32.27	5.38	34.19	123	63	Average

ANTENNA POLARITY : VERTICAL										
Frequency ( MHz )	Level ( dBuV/m )	Over Limit ( dB )	Limit Line ( dBuV/m )	Read Level ( dBuV )	Antenna Factor ( dB )	Cable Loss ( dB )	Preamp Factor ( dB )	Ant Pos ( cm )	Table Pos ( deg )	Remark
2484.61	66.7	-7.3	74	63.24	32.27	5.38	34.19	103	280	Peak
2484.61	44.44	-9.56	54	40.98	32.27	5.38	34.19	103	280	Average

Test Mode :	Mode 10	Temperature :	22~23°C
Test Band :	802.11g	Relative Humidity :	42~43%
Test Channel :	11	Test Engineer :	Kay Wu

ANTENNA POLARITY : HORIZONTAL										
Frequency ( MHz )	Level ( dBuV/m )	Over Limit ( dB )	Limit Line ( dBuV/m )	Read Level ( dBuV )	Antenna Factor ( dB )	Cable Loss ( dB )	Preamp Factor ( dB )	Ant Pos ( cm )	Table Pos ( deg )	Remark
2483.5	67.26	-6.74	74	63.8	32.27	5.38	34.19	100	59	Peak
2483.5	45.9	-8.1	54	42.44	32.27	5.38	34.19	100	59	Average

ANTENNA POLARITY : VERTICAL										
Frequency ( MHz )	Level ( dBuV/m )	Over Limit ( dB )	Limit Line ( dBuV/m )	Read Level ( dBuV )	Antenna Factor ( dB )	Cable Loss ( dB )	Preamp Factor ( dB )	Ant Pos ( cm )	Table Pos ( deg )	Remark
2483.5	66.48	-7.52	74	63.02	32.27	5.38	34.19	103	282	Peak
2483.5	45.09	-8.91	54	41.63	32.27	5.38	34.19	103	282	Average



Test Mode :	Mode 11	Temperature :	22~23°C
Test Band :	802.11g	Relative Humidity :	42~43%
Test Channel :	12	Test Engineer :	Kay Wu

ANTENNA POLARITY : HORIZONTAL										
Frequency ( MHz )	Level ( dBuV/m )	Over Limit ( dB )	Limit Line ( dBuV/m )	Read Level ( dBuV )	Antenna Factor ( dB )	Cable Loss ( dB )	Preamp Factor ( dB )	Ant Pos ( cm )	Table Pos ( deg )	Remark
2483.66	67.64	-6.36	74	64.18	32.27	5.38	34.19	122	63	Peak
2483.66	42.8	-11.2	54	39.34	32.27	5.38	34.19	122	63	Average

ANTENNA POLARITY : VERTICAL										
Frequency ( MHz )	Level ( dBuV/m )	Over Limit ( dB )	Limit Line ( dBuV/m )	Read Level ( dBuV )	Antenna Factor ( dB )	Cable Loss ( dB )	Preamp Factor ( dB )	Ant Pos ( cm )	Table Pos ( deg )	Remark
2483.66	65.83	-8.17	74	62.37	32.27	5.38	34.19	103	281	Peak
2483.66	42.08	-11.92	54	38.62	32.27	5.38	34.19	103	281	Average

Test Mode :	Mode 12	Temperature :	22~23°C
Test Band :	802.11g	Relative Humidity :	42~43%
Test Channel :	13	Test Engineer :	Kay Wu

ANTENNA POLARITY : HORIZONTAL										
Frequency ( MHz )	Level ( dBuV/m )	Over Limit ( dB )	Limit Line ( dBuV/m )	Read Level ( dBuV )	Antenna Factor ( dB )	Cable Loss ( dB )	Preamp Factor ( dB )	Ant Pos ( cm )	Table Pos ( deg )	Remark
2483.85	47.96	-26.04	74	44.5	32.27	5.38	34.19	102	62	Peak
2483.85	32.75	-21.25	54	29.29	32.27	5.38	34.19	102	62	Average

ANTENNA POLARITY : VERTICAL										
Frequency ( MHz )	Level ( dBuV/m )	Over Limit ( dB )	Limit Line ( dBuV/m )	Read Level ( dBuV )	Antenna Factor ( dB )	Cable Loss ( dB )	Preamp Factor ( dB )	Ant Pos ( cm )	Table Pos ( deg )	Remark
2483.85	50.35	-23.65	74	46.89	32.27	5.38	34.19	152	138	Peak
2483.85	33.17	-20.83	54	29.71	32.27	5.38	34.19	152	138	Average



Test Mode :	Mode 13	Temperature :	22~23°C
Test Band :	802.11g	Relative Humidity :	42~43%
Test Channel :	11	Test Engineer :	Kay Wu

ANTENNA POLARITY : HORIZONTAL										
Frequency ( MHz )	Level ( dBuV/m )	Over Limit ( dB )	Limit Line ( dBuV/m )	Read Level ( dBuV )	Antenna Factor ( dB )	Cable Loss ( dB )	Preamp Factor ( dB )	Ant Pos ( cm )	Table Pos ( deg )	Remark
2484.42	59.88	-14.12	74	56.42	32.27	5.38	34.19	117	33	Peak
2484.42	38.62	-15.38	54	35.16	32.27	5.38	34.19	117	33	Average

ANTENNA POLARITY : VERTICAL										
Frequency ( MHz )	Level ( dBuV/m )	Over Limit ( dB )	Limit Line ( dBuV/m )	Read Level ( dBuV )	Antenna Factor ( dB )	Cable Loss ( dB )	Preamp Factor ( dB )	Ant Pos ( cm )	Table Pos ( deg )	Remark
2484.61	53.64	-20.36	74	50.18	32.27	5.38	34.19	153	189	Peak
2484.61	35.04	-18.96	54	31.58	32.27	5.38	34.19	153	189	Average



### 3.3.6 Test Result of Conducted Band Edges

Test Mode :	Mode 1 and 3	Temperature :	24~26°C
Test Band :	802.11b	Relative Humidity :	37~40%
Test Channel :	01 and 11	Test Engineer :	Ken Hsu

Low Band Edge Plot on 802.11b Channel 01

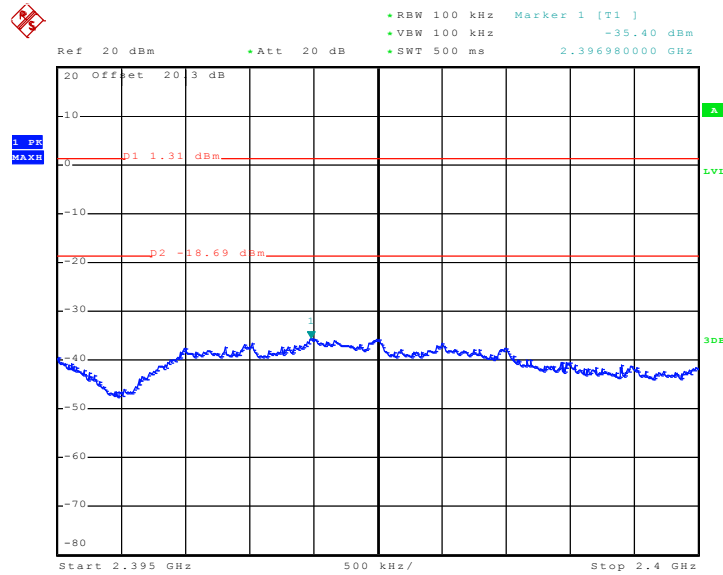

Date: 24.JAN.2010 04:15:26

High Band Edge Plot on 802.11b Channel 11

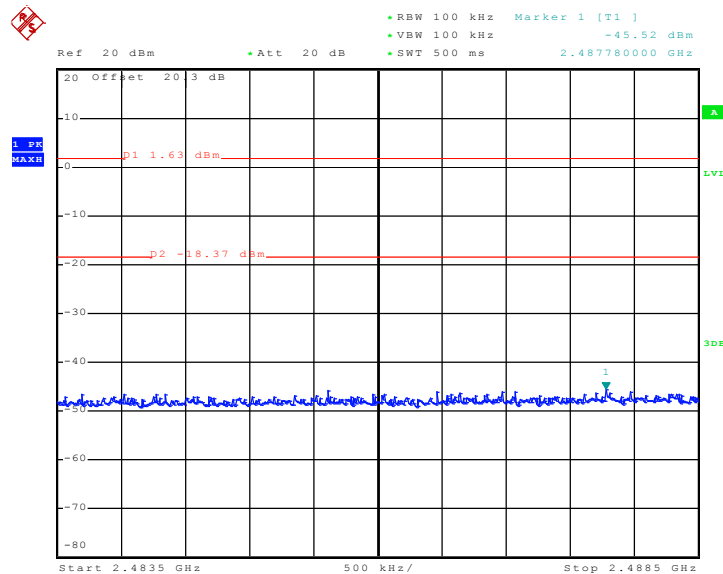

Date: 24.JAN.2010 04:19:32



Test Mode :	Mode 4 and 6	Temperature :	24~26°C
Test Band :	802.11g	Relative Humidity :	37~40%
Test Channel :	01 and 11	Test Engineer :	Ken Hsu

Low Band Edge Plot on 802.11g Channel 01

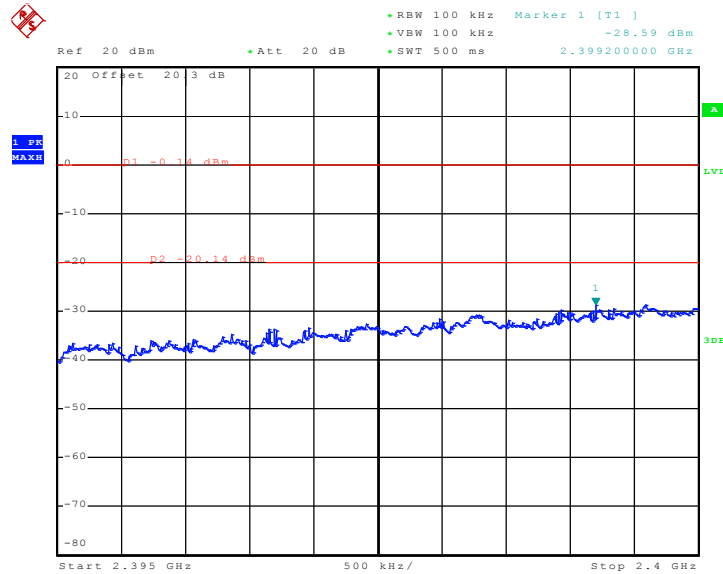

Date: 24.JAN.2010 04:16:22

High Band Edge Plot on 802.11g Channel 11

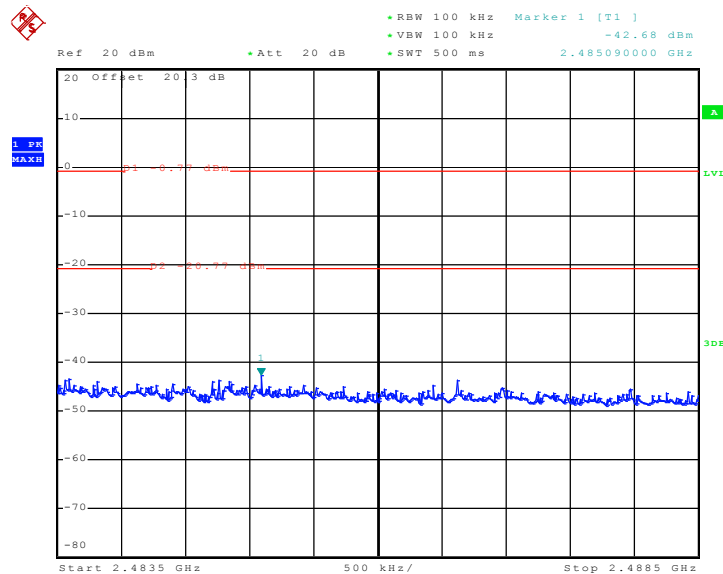

Date: 24.JAN.2010 04:20:25



Test Mode :	Mode 7 and 9	Temperature :	24~26°C
Test Band :	802.11a	Relative Humidity :	37~40%
Test Channel :	149 and 165	Test Engineer :	Ken Hsu

Low Band Edge Plot on 802.11a Channel 149

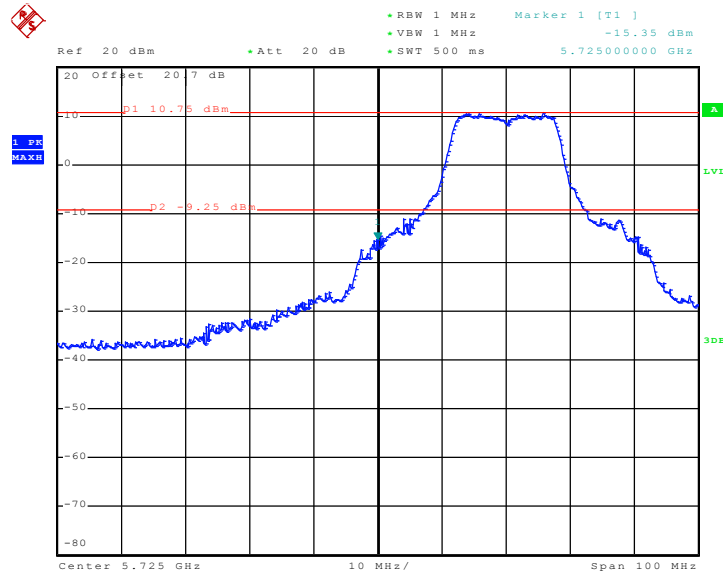

Date: 24.JAN.2010 04:59:49

High Band Edge Plot on 802.11a Channel 165

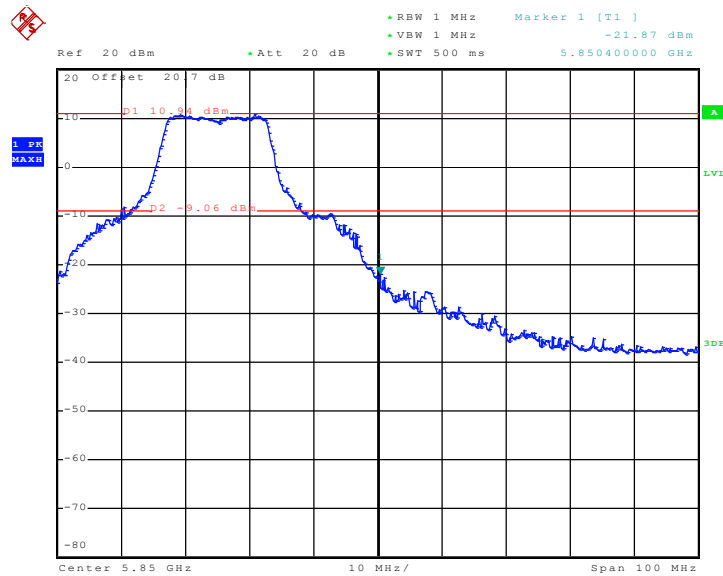

Date: 24.JAN.2010 05:00:42

## 3.4 Spurious Emission Measurement

### 3.4.1 Limit of Spurious Emission Measurement

All harmonics/spurs must be at least 20 dB down from the highest emission level within the authorized band.

### 3.4.2 Measuring Instruments

See list of measuring instruments of this test report.

### 3.4.3 Test Procedure

1. The transmitter output was connected to the spectrum analyzer via a low lose cable.
2. Set RBW = 100 kHz, Video bandwidth (VBW)  $\geq$  RBW, scan up through 10th harmonic. All harmonics/spurs must be at least 20 dB down from the highest emission level within the authorized band as measured with a 100 kHz RBW.

### 3.4.4 Test Setup

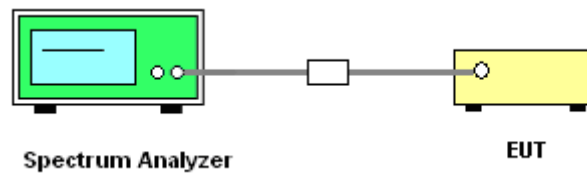

### 3.4.5 Test Result

Test Mode :	Mode 1	Temperature :	24~26°C
Test Band :	802.11b	Relative Humidity :	37~40%
Test Channel :	01	Test Engineer :	Ken Hsu

#### Conducted Spurious Emission Plot between 9 kHz ~ 3 GHz

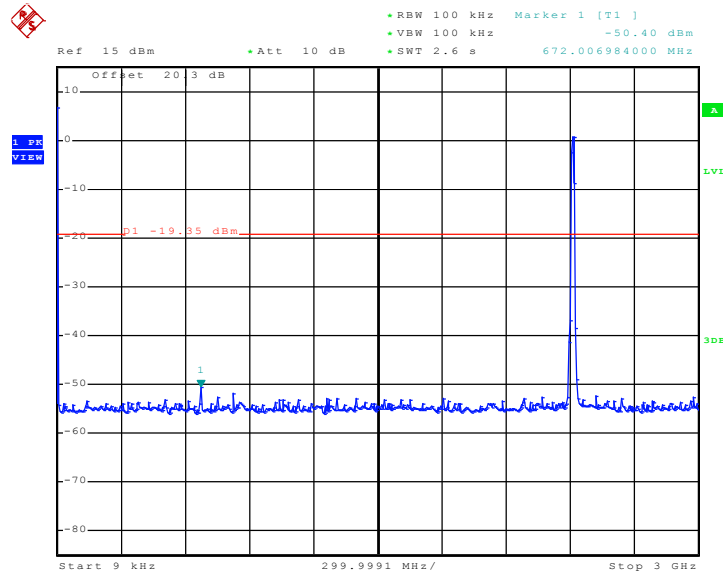

Date: 24.JAN.2010 04:40:50

#### Conducted Spurious Emission Plot between 1 GHz ~ 25 GHz

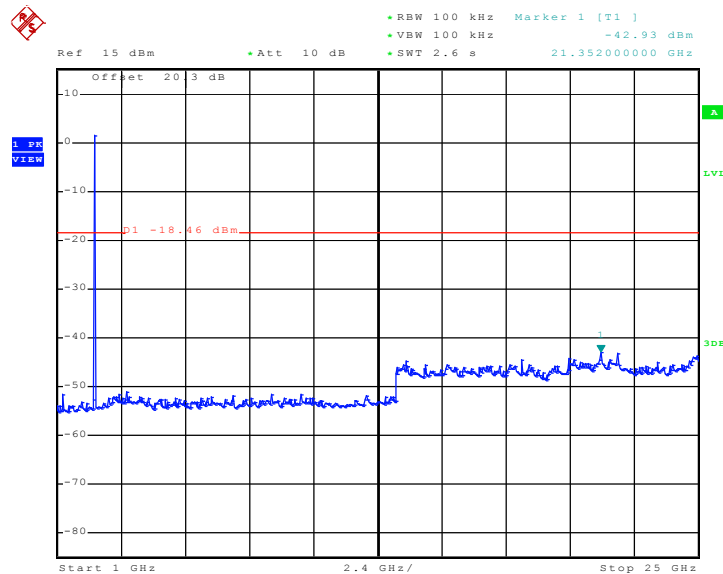

Date: 24.JAN.2010 04:41:16





Test Mode :	Mode 2	Temperature :	24~26°C
Test Band :	802.11b	Relative Humidity :	37~40%
Test Channel :	06	Test Engineer :	Ken Hsu

Conducted Spurious Emission Plot between 9 kHz ~ 3 GHz

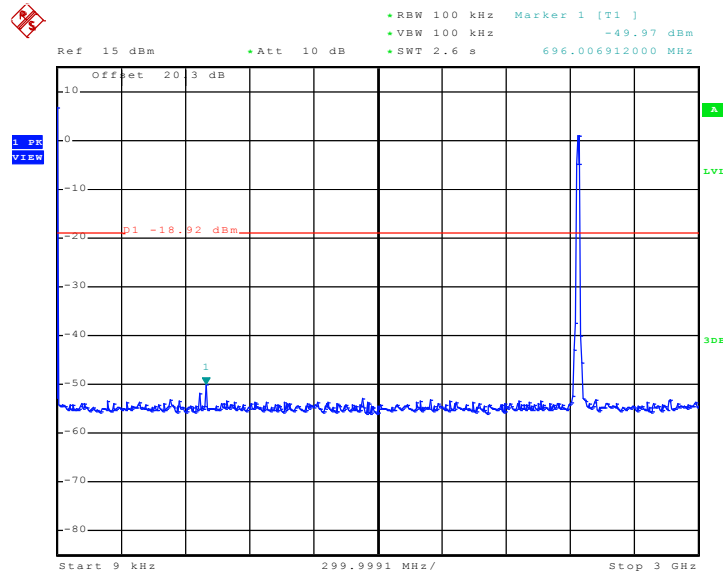

Date: 24.JAN.2010 04:41:53

Conducted Spurious Emission Plot between 1 GHz ~ 25 GHz

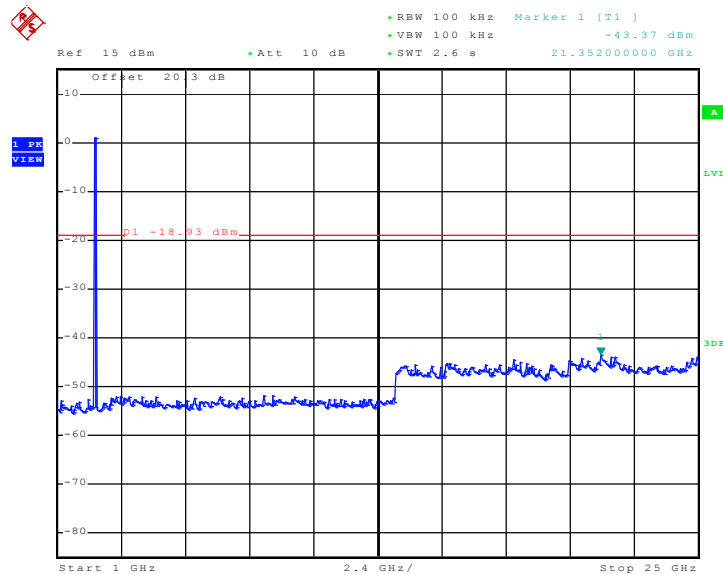

Date: 24.JAN.2010 04:42:14



Test Mode :	Mode 3	Temperature :	24~26°C
Test Band :	802.11b	Relative Humidity :	37~40%
Test Channel :	11	Test Engineer :	Ken Hsu

Conducted Spurious Emission Plot between 9 kHz ~ 3 GHz

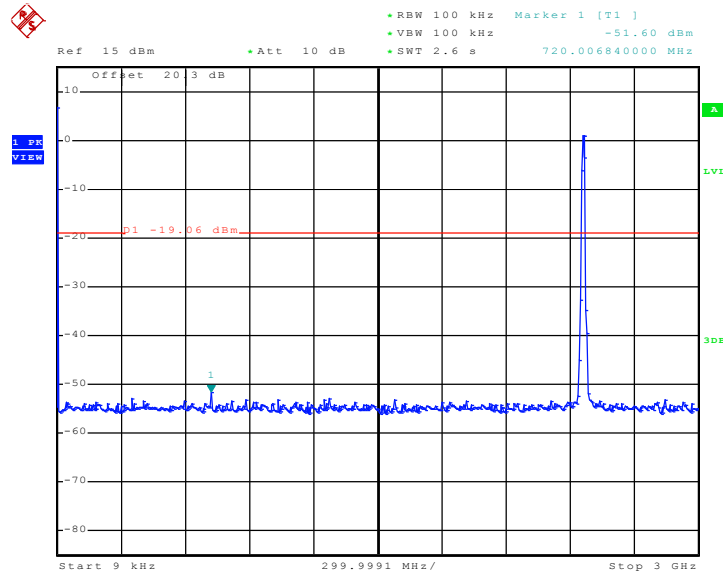

Date: 24.JAN.2010 04:42:54

Conducted Spurious Emission Plot between 1 GHz ~ 25 GHz

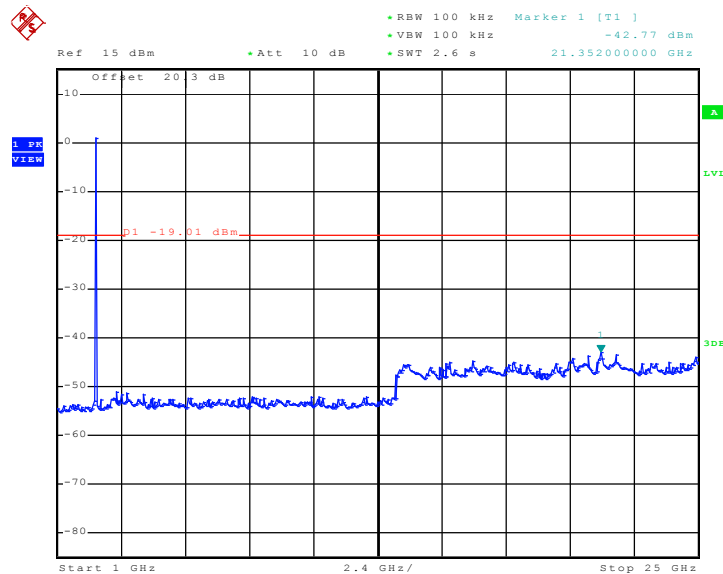

Date: 24.JAN.2010 04:43:15



Test Mode :	Mode 4	Temperature :	24~26°C
Test Band :	802.11g	Relative Humidity :	37~40%
Test Channel :	01	Test Engineer :	Ken Hsu

Conducted Spurious Emission Plot between 9 kHz ~ 3 GHz

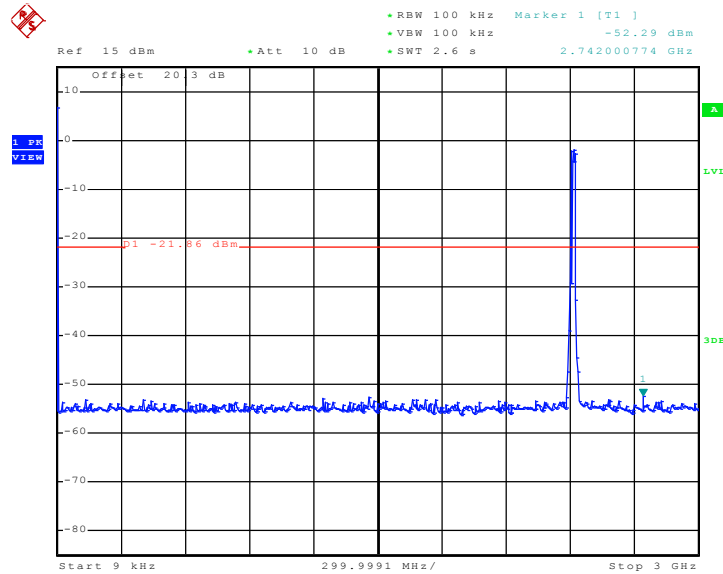

Date: 24.JAN.2010 04:43:46

Conducted Spurious Emission Plot between 1 GHz ~ 25 GHz

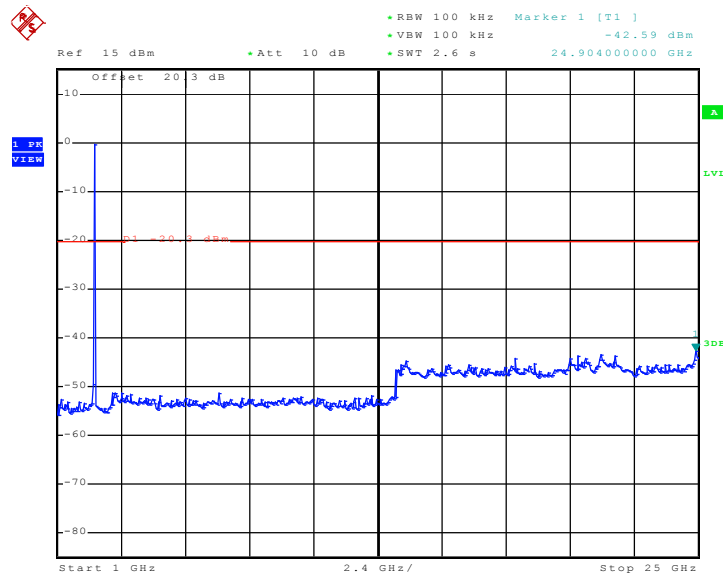

Date: 24.JAN.2010 04:44:08



Test Mode :	Mode 5	Temperature :	24~26°C
Test Band :	802.11g	Relative Humidity :	37~40%
Test Channel :	06	Test Engineer :	Ken Hsu

Conducted Spurious Emission Plot between 9 kHz ~ 3 GHz

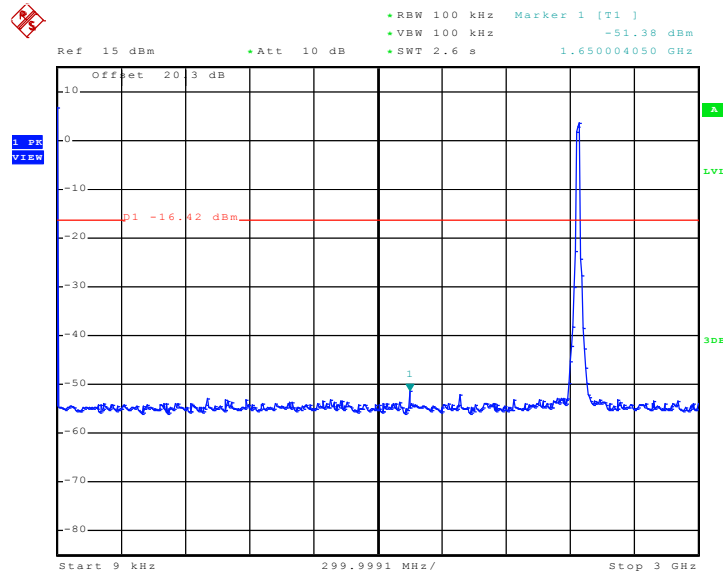

Date: 24.JAN.2010 04:44:55

Conducted Spurious Emission Plot between 1 GHz ~ 25 GHz

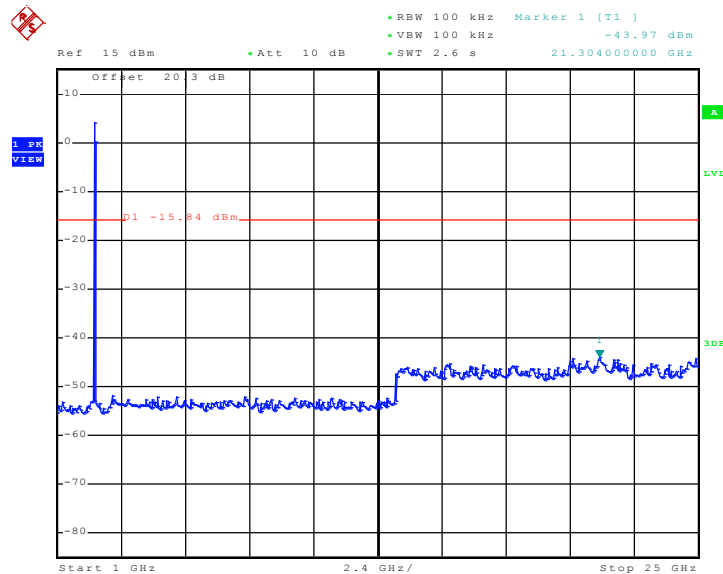

Date: 24.JAN.2010 04:45:10



Test Mode :	Mode 6	Temperature :	24~26°C
Test Band :	802.11g	Relative Humidity :	37~40%
Test Channel :	11	Test Engineer :	Ken Hsu

Conducted Spurious Emission Plot between 9 kHz ~ 3 GHz

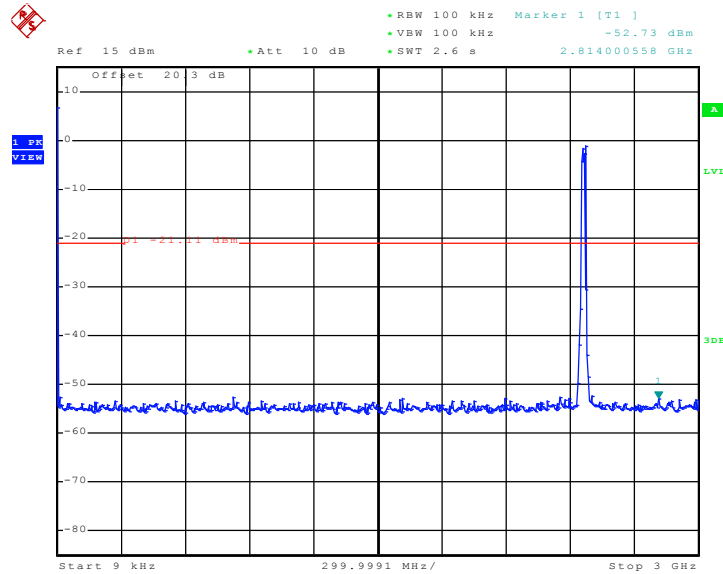

Date: 24.JAN.2010 04:45:40

Conducted Spurious Emission Plot between 1 GHz ~ 25 GHz

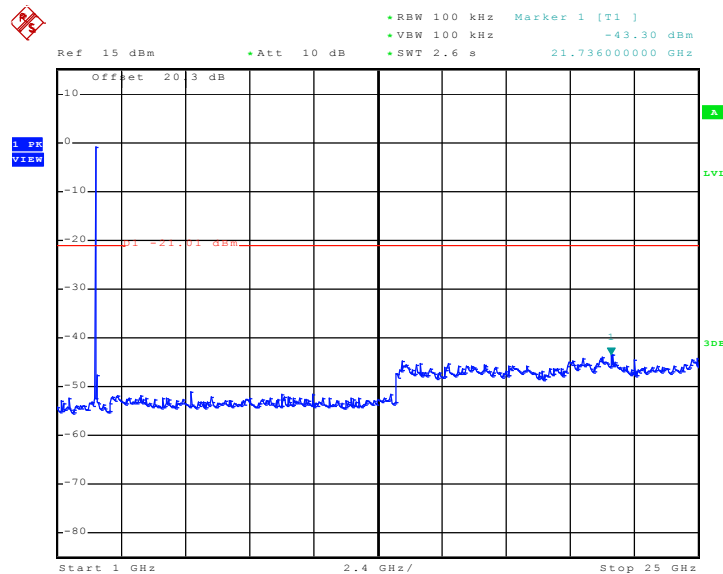

Date: 24.JAN.2010 04:46:01



Test Mode :	Mode 7	Temperature :	24~26°C
Test Band :	802.11a	Relative Humidity :	37~40%
Test Channel :	149	Test Engineer :	Ken Hsu

Conducted Spurious Emission Plot between 30 MHz ~ 40 GHz

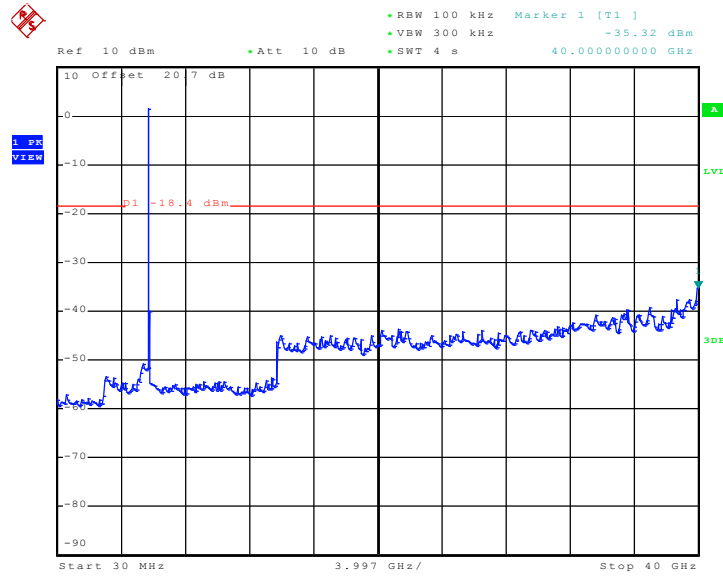

Date: 24.JAN.2010 04:50:57



Test Mode :	Mode 8	Temperature :	24~26°C
Test Band :	802.11a	Relative Humidity :	37~40%
Test Channel :	157	Test Engineer :	Ken Hsu

Conducted Spurious Emission Plot between 30 MHz ~ 40 GHz

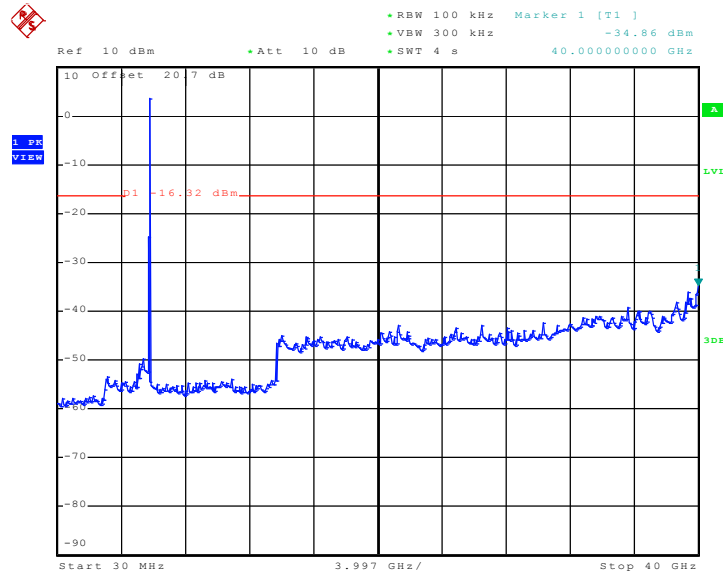

Date: 24.JAN.2010 04:51:46



Test Mode :	Mode 9	Temperature :	24~26°C
Test Band :	802.11a	Relative Humidity :	37~40%
Test Channel :	165	Test Engineer :	Ken Hsu

Conducted Spurious Emission Plot between 30 MHz ~ 40 GHz

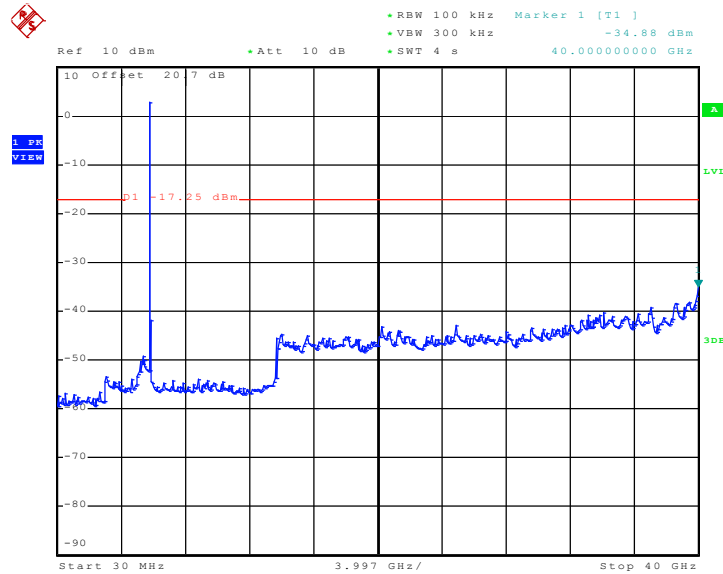

Date: 24.JAN.2010 04:52:30



## 3.5 Power Spectral Density Measurement

### 3.5.1 Limit of Power Spectral Density

The peak power spectral density shall not be greater than 8dBm in any 3 kHz band at any time interval of continuous transmission.

### 3.5.2 Measuring Instruments

See list of measuring instruments of this test report.

### 3.5.3 Test Procedures

1. The test follows FCC KDB Publication No. 558074 (Measurement Guidelines of DTS).
2. The RF output of EUT was connected to the spectrum analyzer by a low loss cable.
3. Take the measured data from spectrum analyzer.

### 3.5.4 Test Setup

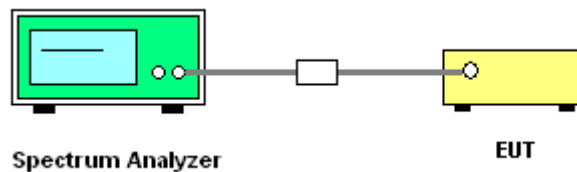



3.5.5 Test Result of Power Spectral Density

Test Mode :	Mode 1, 2, 3	Temperature :	24~26°C
Test Engineer :	Ken Hsu	Relative Humidity :	37~40%

Channel	Frequency (MHz)	802.11b Measured PSD (dBm)	Max. Limits (dBm)	Pass/Fail
01	2412	-12.44	8	Pass
06	2437	-12.17	8	Pass
11	2462	-12.02	8	Pass

Mode 1 : PSD Plot on 802.11b Channel 01

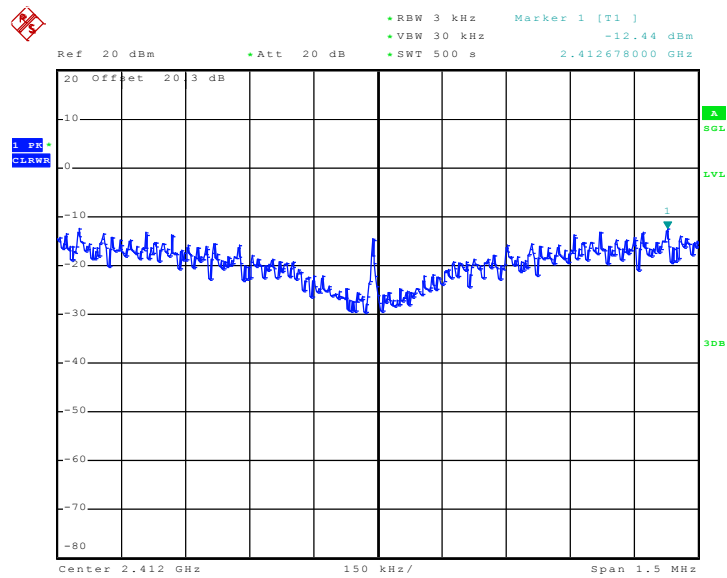

Date: 24.JAN.2010 05:42:36



Mode 2 : PSD Plot on 802.11b Channel 06

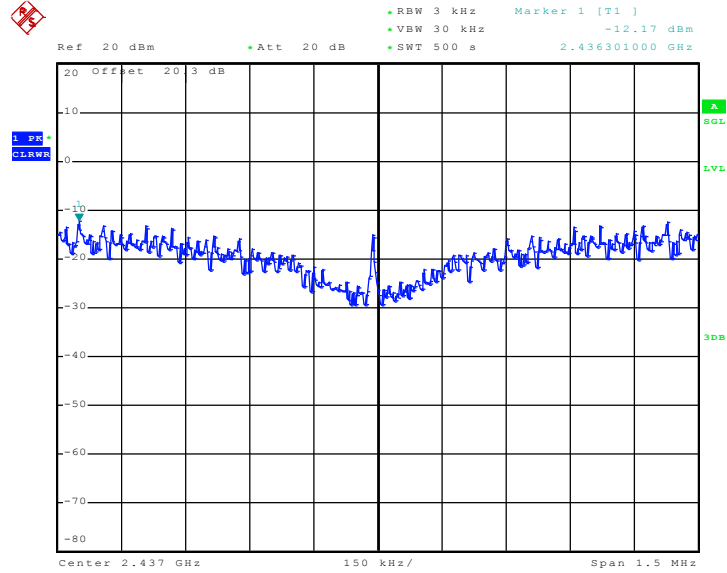

Date: 24.JAN.2010 05:57:50

Mode 3 : PSD Plot on 802.11b Channel 11

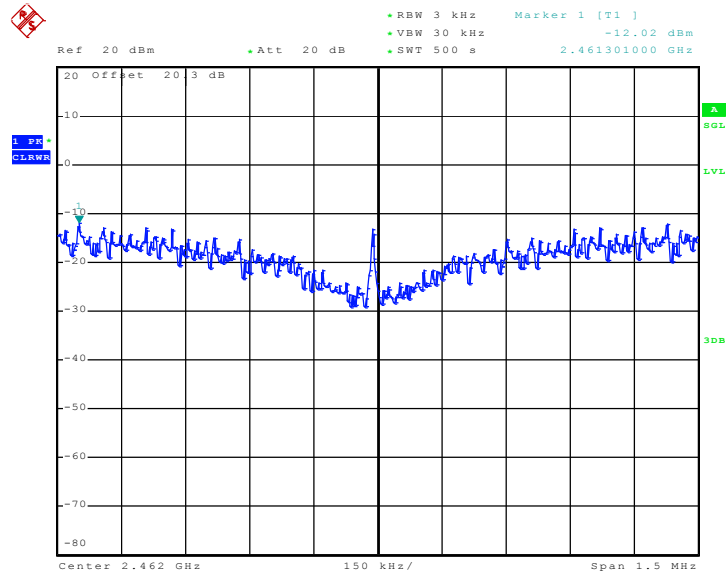

Date: 24.JAN.2010 06:07:03



Test Mode :	Mode 4, 5, 6	Temperature :	24~26°C
Test Engineer :	Ken Hsu	Relative Humidity :	37~40%

Channel	Frequency (MHz)	802.11g Measured PSD (dBm)	Max. Limits (dBm)	Pass/Fail
01	2412	-13.88	8	Pass
06	2437	-9.15	8	Pass
11	2462	-14.43	8	Pass

Mode 4 : PSD Plot on 802.11g Channel 01

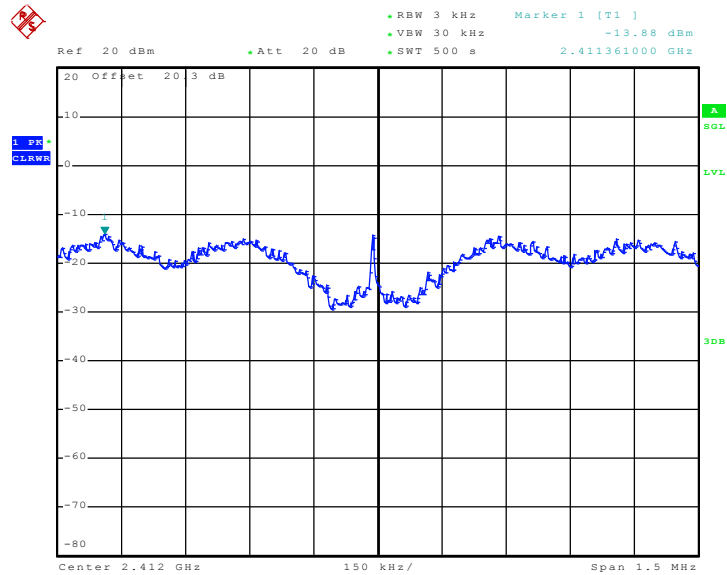

Date: 24..JAN..2010 06:16:02



Mode 5 : PSD Plot on 802.11g Channel 06

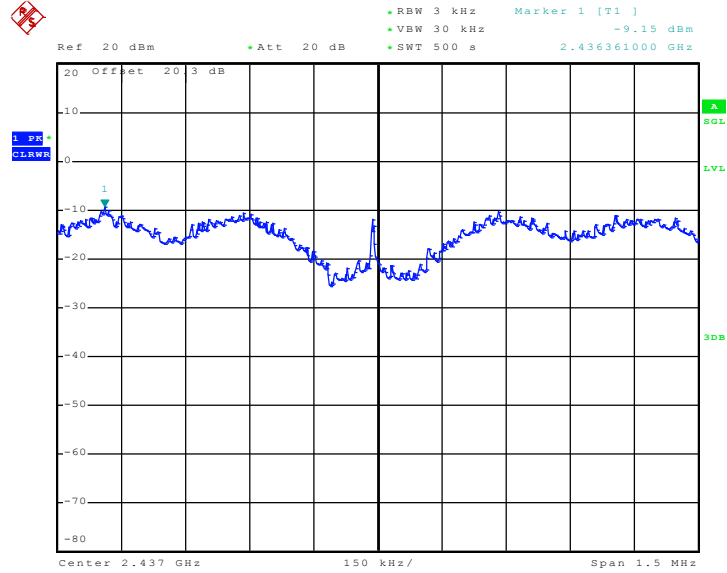

Date: 24.JAN.2010 06:24:55

Mode 6 : PSD Plot on 802.11g Channel 11

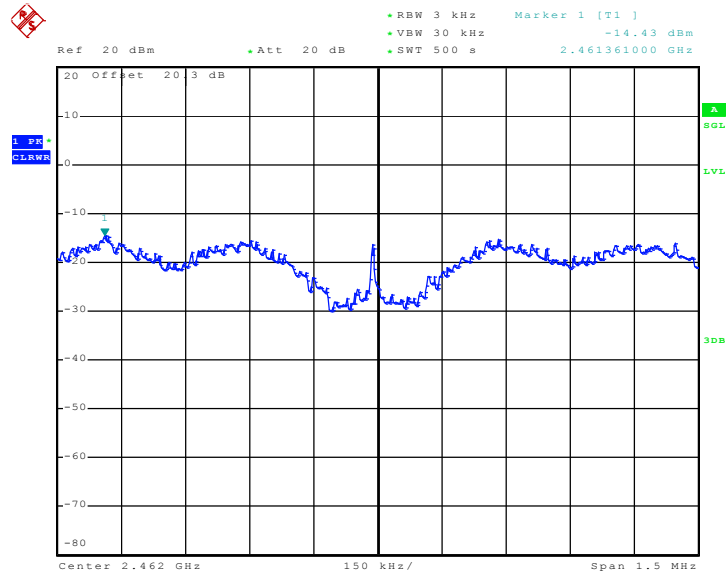

Date: 24.JAN.2010 06:34:20



Test Mode :	Mode 7, 8, 9	Temperature :	24~26
Test Engineer :	Ken Hsu	Relative Humidity :	37~40

Channel	Frequency (MHz)	802.11a Measured PSD (dBm)	Max. Limits (dBm)	Pass/Fail
149	5745	-11.23	8	Pass
157	5785	-10.76	8	Pass
165	5825	-10.72	8	Pass

Mode 7 : PSD Plot on 802.11a Channel 149

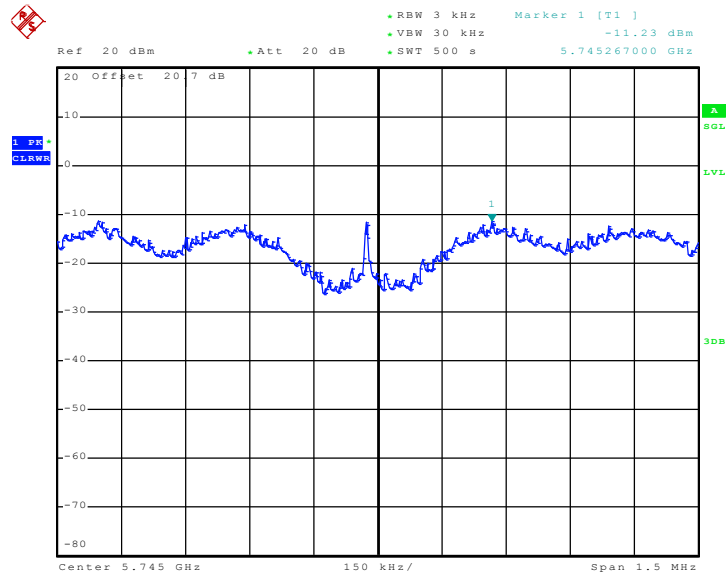

Date: 24..JAN..2010 05:10:20



Mode 8 : PSD Plot on 802.11a Channel 157

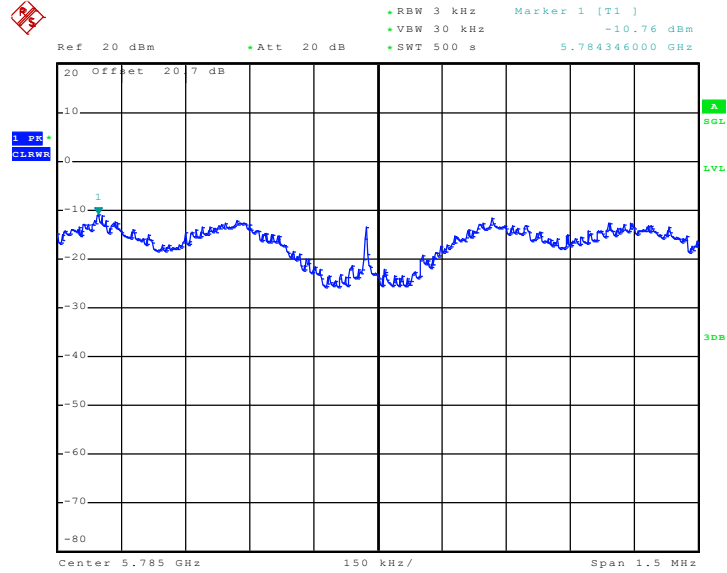

Date: 24.JAN.2010 05:19:07

Mode 9 : PSD Plot on 802.11a Channel 165

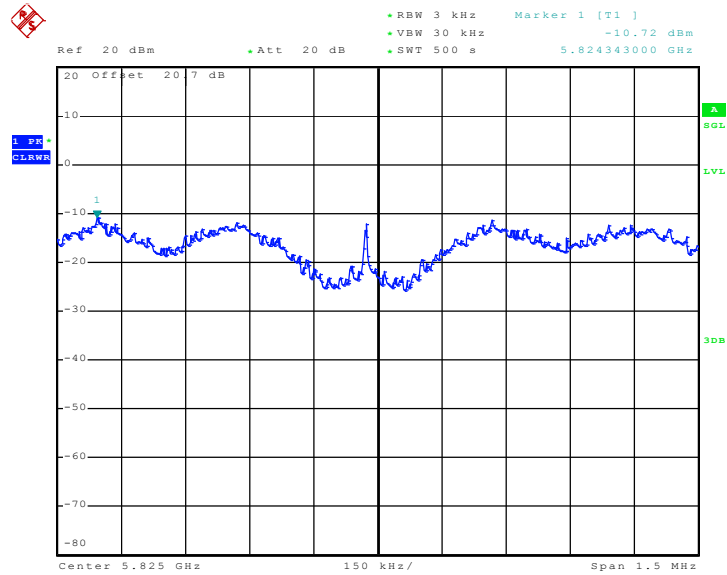

Date: 24.JAN.2010 05:28:11

## 3.6 AC Conducted Emission Measurement

### 3.6.1 Limit of AC Conducted Emission

For equipment that is designed to be connected to the public utility (AC) power line, the radio frequency voltage that is conducted back onto the AC power line on any frequency or frequencies within the band 150 kHz to 30 MHz shall not exceed the limits in the following table.

Frequency of Emission (MHz)	Conducted Limit (dBuV)	
	Quasi-Peak	Average
0.15-0.5	66 to 56*	56 to 46*
0.5-5	56	46
5-30	60	50

\*Decreases with the logarithm of the frequency.

### 3.6.2 Measuring Instruments

See list of measuring instruments of this test report.

### 3.6.3 Test Procedures

1. The testing follows the guidelines in ANSI C63.4-2003.
2. The EUT was placed 0.4 meter from the conducting wall of the shielding room, and it was kept at least 80 centimeters from any other grounded conducting surface.
3. Connect EUT to the power mains through a line impedance stabilization network (LISN).
4. All the support units are connecting to the other LISN.
5. The LISN provides 50 ohm coupling impedance for the measuring instrument.
6. The FCC states that a 50 ohm, 50 microhenry LISN should be used.
7. Both sides of AC line were checked for maximum conducted interference.
8. The frequency range from 150 kHz to 30 MHz was searched.
9. Set the test-receiver system to Peak Detect Function and specified bandwidth with Maximum Hold Mode.



### 3.6.4 Test Setup

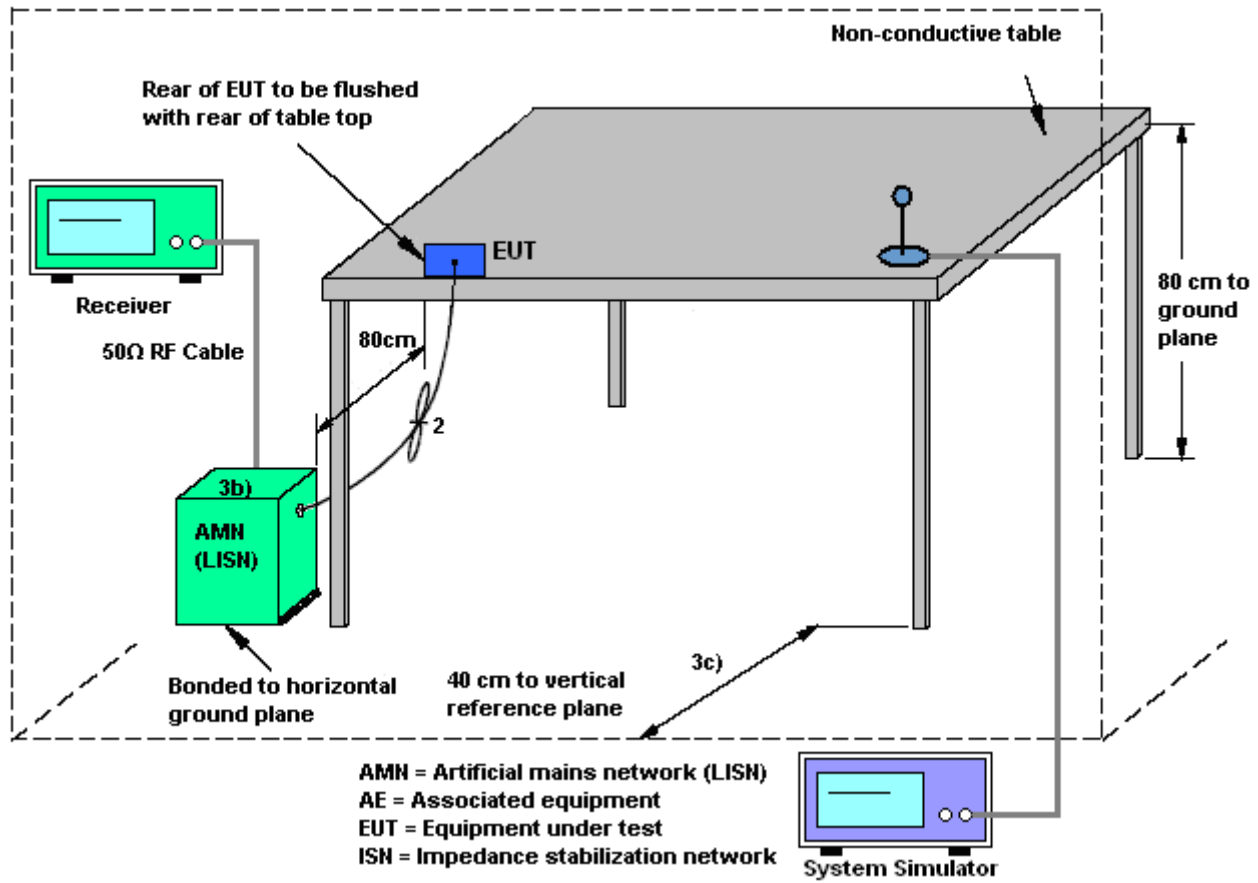

### 3.6.5 Test Result of AC Conducted Emission

Test Mode :	Mode 1	Temperature :	20~22°C
Test Engineer :	Hayden Wu	Relative Humidity :	41~44%
Test Voltage :	120Vac / 60Hz	Phase :	Line
Function Type :	GSM 850 Idle + WLAN Link (2.4G) + Bluetooth Link + GPS Rx + USB Charging Cable with AC Power + USB Link + Camera + MP3 + Qwerty Keypad		
Remark :	All emissions not reported here are more than 10 dB below the prescribed limit.		

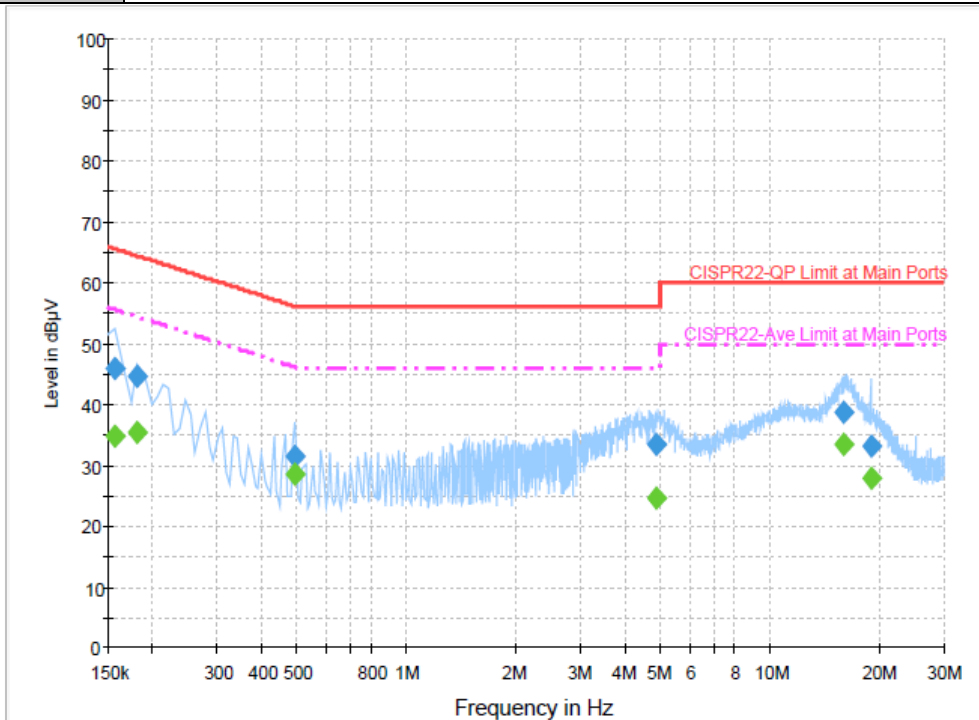

#### Final Result 1

Frequency (MHz)	QuasiPeak (dBµV)	Filter	Line	Corr. (dB)	Margin (dB)	Limit (dBµV)
0.158000	46.0	Off	L1	19.5	19.6	65.6
0.182000	44.4	Off	L1	19.5	20.0	64.4
0.494000	31.5	Off	L1	19.4	24.6	56.1
4.862000	33.4	Off	L1	19.5	22.6	56.0
15.878000	38.6	Off	L1	19.7	21.4	60.0
18.870000	33.2	Off	L1	19.7	26.8	60.0

#### Final Result 2

Frequency (MHz)	Average (dBµV)	Filter	Line	Corr. (dB)	Margin (dB)	Limit (dBµV)
0.158000	34.7	Off	L1	19.5	20.9	55.6
0.182000	35.3	Off	L1	19.5	19.1	54.4
0.494000	28.5	Off	L1	19.4	17.6	46.1
4.862000	24.6	Off	L1	19.5	21.4	46.0
15.878000	33.3	Off	L1	19.7	16.7	50.0
18.870000	27.9	Off	L1	19.7	22.1	50.0



Test Mode :	Mode 1	Temperature :	20~22°C
Test Engineer :	Hayden Wu	Relative Humidity :	41~44%
Test Voltage :	120Vac / 60Hz	Phase :	Neutral
Function Type :	GSM 850 Idle + WLAN Link (2.4G) + Bluetooth Link + GPS Rx + USB Charging Cable with AC Power + USB Link + Camera + MP3 + Qwerty Keypad		
Remark :	All emissions not reported here are more than 10 dB below the prescribed limit.		

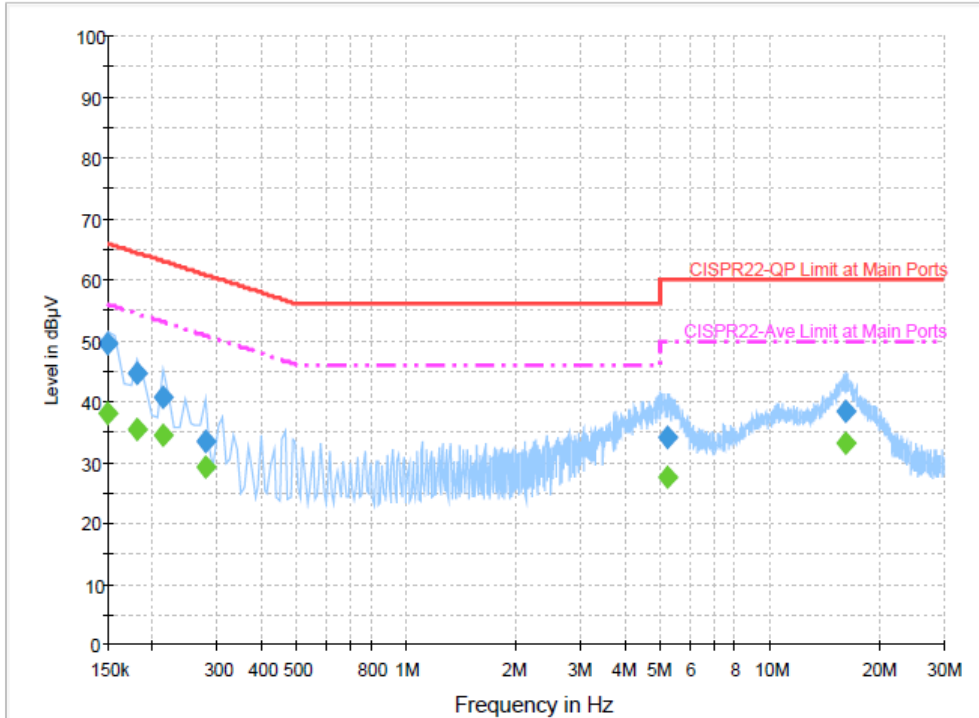

Final Result 1

Frequency (MHz)	QuasiPeak (dBµV)	Filter	Line	Corr. (dB)	Margin (dB)	Limit (dBµV)
0.150000	49.4	Off	N	19.5	16.6	66.0
0.182000	44.6	Off	N	19.5	19.8	64.4
0.214000	40.5	Off	N	19.5	22.5	63.0
0.278000	33.6	Off	N	19.5	27.3	60.9
5.214000	34.2	Off	N	19.5	25.8	60.0
16.086000	38.4	Off	N	19.8	21.6	60.0

Final Result 2

Frequency (MHz)	Average (dBµV)	Filter	Line	Corr. (dB)	Margin (dB)	Limit (dBµV)
0.150000	38.0	Off	N	19.5	18.0	56.0
0.182000	35.5	Off	N	19.5	18.9	54.4
0.214000	34.4	Off	N	19.5	18.6	53.0
0.278000	29.2	Off	N	19.5	21.7	50.9
5.214000	27.4	Off	N	19.5	22.6	50.0
16.086000	33.1	Off	N	19.8	16.9	50.0



Test Mode :	Mode 2	Temperature :	20~22°C
Test Engineer :	Hayden Wu	Relative Humidity :	41~44%
Test Voltage :	120Vac / 60Hz	Phase :	Line
Function Type :	WCDMA Band V Idle + WLAN Link (2.4G) + Bluetooth Link + GPS Rx + USB Charging Cable with AC Power + USB Link + Scanner + MP3 + Qwerty Keypad		
Remark :	All emissions not reported here are more than 10 dB below the prescribed limit.		

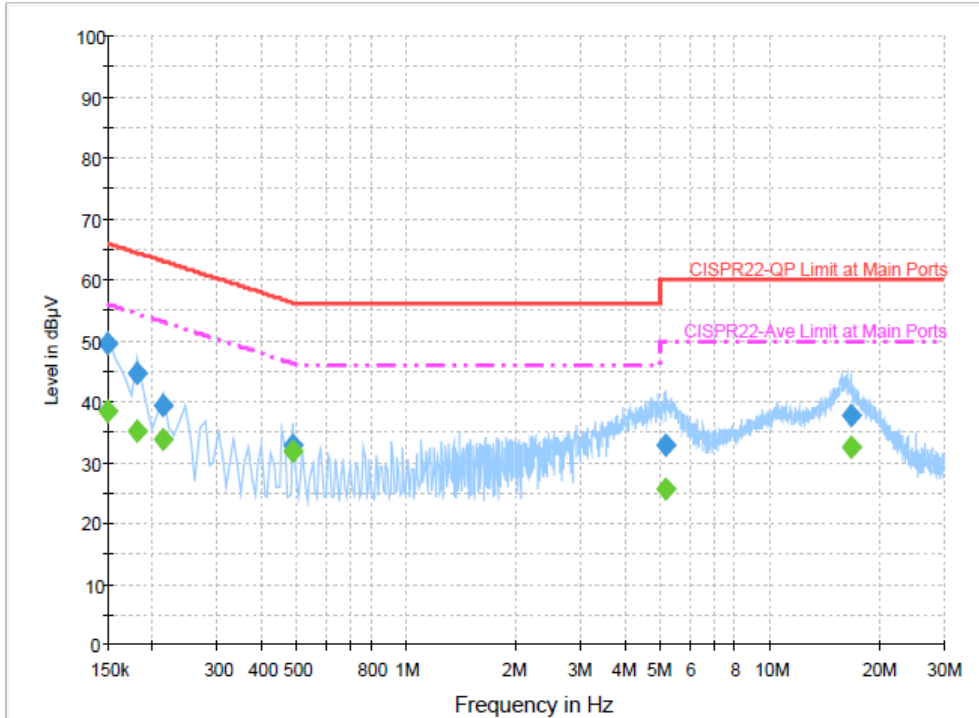

Final Result 1

Frequency (MHz)	QuasiPeak (dBµV)	Filter	Line	Corr. (dB)	Margin (dB)	Limit (dBµV)
0.150000	49.6	Off	L1	19.5	16.4	66.0
0.182000	44.6	Off	L1	19.5	19.8	64.4
0.214000	39.4	Off	L1	19.5	23.6	63.0
0.486000	32.6	Off	L1	19.4	23.6	56.2
5.126000	32.7	Off	L1	19.5	27.3	60.0
16.606000	37.7	Off	L1	19.7	22.3	60.0

Final Result 2

Frequency (MHz)	Average (dBµV)	Filter	Line	Corr. (dB)	Margin (dB)	Limit (dBµV)
0.150000	38.4	Off	L1	19.5	17.6	56.0
0.182000	35.2	Off	L1	19.5	19.2	54.4
0.214000	33.7	Off	L1	19.5	19.3	53.0
0.486000	31.9	Off	L1	19.4	14.3	46.2
5.126000	25.6	Off	L1	19.5	24.4	50.0
16.606000	32.3	Off	L1	19.7	17.7	50.0



Test Mode :	Mode 2	Temperature :	20~22°C
Test Engineer :	Hayden Wu	Relative Humidity :	41~44%
Test Voltage :	120Vac / 60Hz	Phase :	Neutral
Function Type :	WCDMA Band V Idle + WLAN Link (2.4G) + Bluetooth Link + GPS Rx + USB Charging Cable with AC Power + USB Link + Scanner + MP3 + Qwerty Keypad		
Remark :	All emissions not reported here are more than 10 dB below the prescribed limit.		

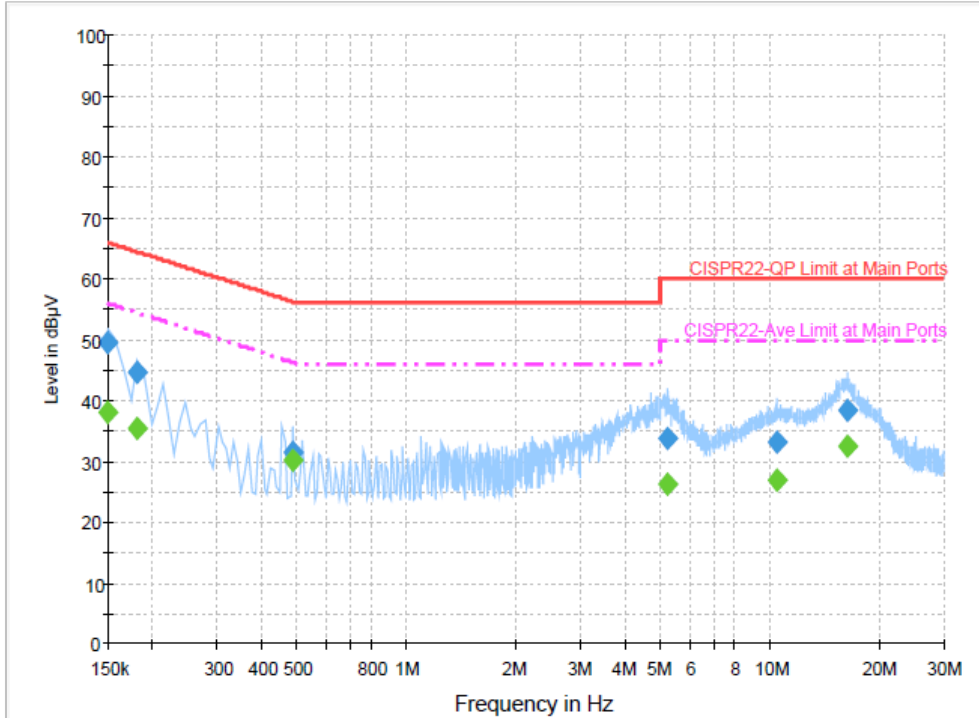

Final Result 1

Frequency (MHz)	QuasiPeak (dBµV)	Filter	Line	Corr. (dB)	Margin (dB)	Limit (dBµV)
0.150000	49.7	Off	N	19.5	16.3	66.0
0.182000	44.6	Off	N	19.5	19.8	64.4
0.486000	31.3	Off	N	19.4	24.9	56.2
5.238000	33.9	Off	N	19.5	26.1	60.0
10.446000	33.1	Off	N	19.6	26.9	60.0
16.350000	38.2	Off	N	19.8	21.8	60.0

Final Result 2

Frequency (MHz)	Average (dBµV)	Filter	Line	Corr. (dB)	Margin (dB)	Limit (dBµV)
0.150000	38.1	Off	N	19.5	17.9	56.0
0.182000	35.5	Off	N	19.5	18.9	54.4
0.486000	30.1	Off	N	19.4	16.1	46.2
5.238000	26.3	Off	N	19.5	23.7	50.0
10.446000	26.9	Off	N	19.6	23.1	50.0
16.350000	32.6	Off	N	19.8	17.4	50.0



Test Mode :	Mode 3	Temperature :	20~22°C
Test Engineer :	Hayden Wu	Relative Humidity :	41~44%
Test Voltage :	120Vac / 60Hz	Phase :	Line
Function Type :	CDMA2000 BC0 Idle + WLAN Link (2.4G) + Bluetooth Link + GPS Rx + USB Charging Cable with AC Power + USB Link + Camera + MP3 + Numeric Keypad		
Remark :	All emissions not reported here are more than 10 dB below the prescribed limit.		

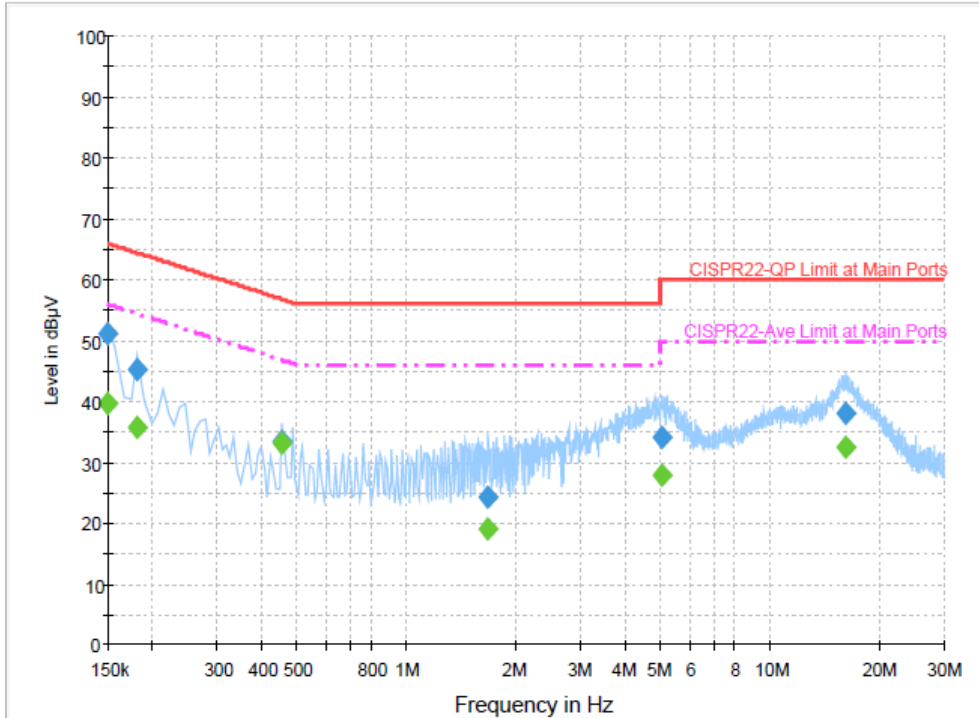

Final Result 1

Frequency (MHz)	QuasiPeak (dBµV)	Filter	Line	Corr. (dB)	Margin (dB)	Limit (dBµV)
0.150000	51.0	Off	L1	19.5	15.0	66.0
0.182000	45.4	Off	L1	19.5	19.0	64.4
0.454000	33.6	Off	L1	19.4	23.2	56.8
1.670000	24.1	Off	L1	19.5	31.9	56.0
5.046000	34.2	Off	L1	19.5	25.8	60.0
16.158000	37.9	Off	L1	19.7	22.1	60.0

Final Result 2

Frequency (MHz)	Average (dBµV)	Filter	Line	Corr. (dB)	Margin (dB)	Limit (dBµV)
0.150000	39.6	Off	L1	19.5	16.4	56.0
0.182000	35.7	Off	L1	19.5	18.7	54.4
0.454000	33.1	Off	L1	19.4	13.7	46.8
1.670000	19.0	Off	L1	19.5	27.0	46.0
5.046000	27.9	Off	L1	19.5	22.1	50.0
16.158000	32.5	Off	L1	19.7	17.5	50.0



Test Mode :	Mode 3	Temperature :	20~22°C
Test Engineer :	Hayden Wu	Relative Humidity :	41~44%
Test Voltage :	120Vac / 60Hz	Phase :	Neutral
Function Type :	CDMA2000 BC0 Idle + WLAN Link (2.4G) + Bluetooth Link + GPS Rx + USB Charging Cable with AC Power + USB Link + Camera + MP3 + Numeric Keypad		
Remark :	All emissions not reported here are more than 10 dB below the prescribed limit.		

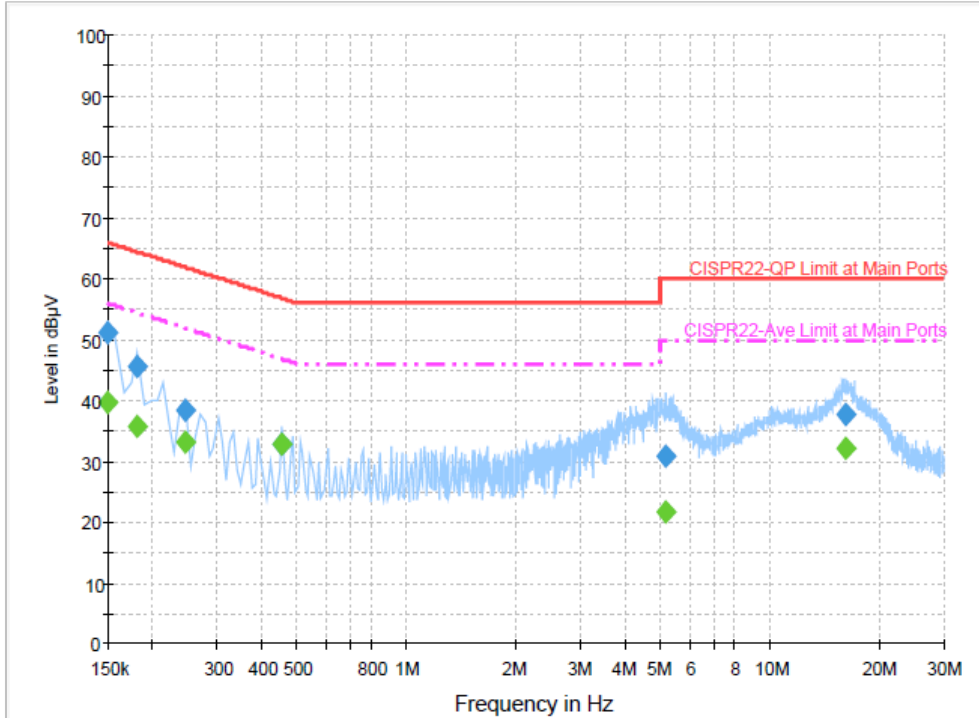

Final Result 1

Frequency (MHz)	QuasiPeak (dBµV)	Filter	Line	Corr. (dB)	Margin (dB)	Limit (dBµV)
0.150000	51.3	Off	N	19.5	14.7	66.0
0.182000	45.5	Off	N	19.5	18.9	64.4
0.246000	38.5	Off	N	19.5	23.4	61.9
0.454000	32.7	Off	N	19.4	24.1	56.8
5.174000	30.7	Off	N	19.5	29.3	60.0
16.142000	37.6	Off	N	19.8	22.4	60.0

Final Result 2

Frequency (MHz)	Average (dBµV)	Filter	Line	Corr. (dB)	Margin (dB)	Limit (dBµV)
0.150000	39.6	Off	N	19.5	16.4	56.0
0.182000	35.9	Off	N	19.5	18.5	54.4
0.246000	33.0	Off	N	19.5	18.9	51.9
0.454000	32.7	Off	N	19.4	14.1	46.8
5.174000	21.7	Off	N	19.5	28.3	50.0
16.142000	32.1	Off	N	19.8	17.9	50.0

### 3.7 Radiated Emission Measurement

#### 3.7.1 Limit of Radiated Emission

In any 100 kHz bandwidth outside the intentional radiator frequency band, all harmonics/spurious must be at least 20 dB below the highest emission level within the authorized band. If the output power of this device was measured by spectrum analyzer, the attenuation under this paragraph shall be 30 dB instead of 20 dB. In addition, radiated emissions which fall in the restricted bands must also comply with the FCC section 15.209 limits as below.

Frequency (MHz)	Field Strength (microvolts/meter)	Measurement Distance (meters)
0.009 – 0.490	2400/F(kHz)	300
0.490 – 1.705	24000/F(kHz)	30
1.705 – 30.0	30	30
30 – 88	100	3
88 – 216	150	3
216 - 960	200	3
Above 960	500	3

#### 3.7.2 Measuring Instruments

See list of measuring instruments of this test report.

#### 3.7.3 Test Procedures

- The testing follows the guidelines in FCC KDB Publication No. 558074 (Measurement Guidelines of DTS).
- Use the following spectrum analyzer settings:
  - Span = wide enough to fully capture the emission being measured; RBW = 1 MHz for  $f \geq 1$  GHz, 100 kHz for  $f < 1$  GHz; VBW  $\geq$  RBW; Sweep = auto; Detector function = peak; Trace = max hold.
  - Above 18 GHz shall be extrapolated to the specified distance using an extrapolation factor of 20 dB/decade from 3m to 1m.  
 Distance extrapolation factor =  $20 \log(\text{specific distance [3m]} / \text{test distance [1m]})$  (dB)
- Follow the guidelines in ANSI C63.4-2003 with respect to maximizing the emission by rotating the EUT, measuring the emission for three EUT orthogonal planes, and adjusting the measurement antenna height and polarization. A pre-amp and a high pass filter are used for this test in order to get the good signal level.



### 3.7.4 Test Setup

For radiated emissions below 30MHz

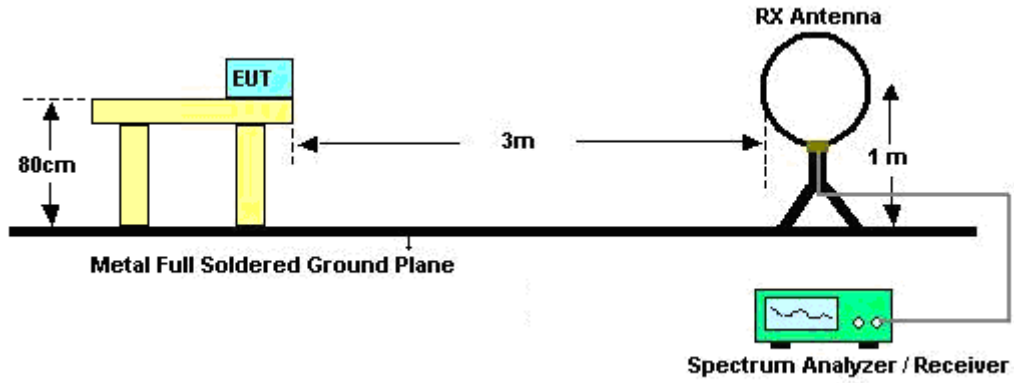

For radiated emissions above 30MHz

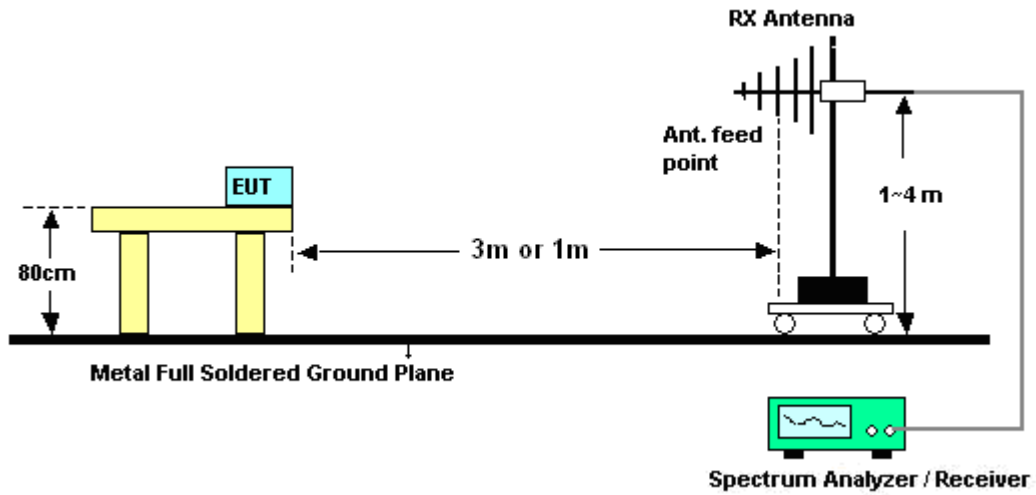



3.7.5 Test Results of Radiated Emissions (9kHz ~ 30MHz)

Test Engineer :	Kay Wu	Temperature :	22~23°C	
		Relative Humidity :	42~43%	
Frequency (MHz)	Level (dBuV)	Over Limit (dB)	Limit Line (dBuV)	Remark
-	-	-	-	See Note

Note:

The amplitude of spurious emissions that are attenuated by more than 20dB below the permissible value has no need to be reported.

Distance extrapolation factor =  $40 \log(\text{specific distance} / \text{test distance})$  (dB);

Limit line = specific limits (dBuV) + distance extrapolation factor.



3.7.6 Test Result of Radiated Emission (30MHz ~ 10<sup>th</sup> Harmonic)

Test Mode :	Mode 1	Temperature :	22~23°C
Test Channel :	01	Relative Humidity :	42~43%
Test Engineer :	Kay Wu	Polarization :	Horizontal
Remark :	2412 MHz is Fundamental Signals which can be ignored.		

Frequency ( MHz )	Level ( dBuV/m )	Over Limit ( dB )	Limit Line ( dBuV/m )	Read Level (dBuV)	Antenna Factor ( dB )	Cable Loss ( dB )	Preamp Factor ( dB )	Ant Pos ( cm )	Table Pos ( deg )	Remark
46.74	25.92	-14.08	40	46.92	9.94	0.76	31.7	100	114	Peak
142.86	25.12	-18.38	43.5	43.8	11.56	1.42	31.66	-	-	Peak
180.66	21.57	-21.93	43.5	42.53	9.04	1.62	31.62	-	-	Peak
399.4	25.32	-20.68	46	37.87	16.11	2.54	31.2	-	-	Peak
514.9	22.34	-23.66	46	31.99	18.46	2.98	31.09	-	-	Peak
881	27.59	-18.41	46	31.22	22.99	4.08	30.7	-	-	Peak
2385.81	49.92	-24.08	74	46.48	32.13	5.46	34.15	100	7	Peak
2385.81	39.62	-14.38	54	36.18	32.13	5.46	34.15	100	7	Average
2412	104.52	-	-	101.08	32.16	5.44	34.16	100	7	Peak
2412	100.39	-	-	96.95	32.16	5.44	34.16	100	7	Average
2500	32.92	-21.08	54	29.45	32.3	5.37	34.2	100	7	Average
2500	46.73	-27.27	74	43.26	32.3	5.37	34.2	100	7	Peak
8373	54.73	-19.27	74	43.73	36	10.1	35.1	100	73	Peak
8373	40.15	-13.85	54	29.15	36	10.1	35.1	100	73	Average



<b>Test Mode :</b>	Mode 1	<b>Temperature :</b>	22~23°C
<b>Test Channel :</b>	01	<b>Relative Humidity :</b>	42~43%
<b>Test Engineer :</b>	Kay Wu	<b>Polarization :</b>	Vertical
<b>Remark :</b>	2412 MHz is Fundamental Signals which can be ignored.		

Frequency ( MHz )	Level ( dBuV/m )	Over Limit ( dB )	Limit Line ( dBuV/m )	Read Level ( dBuV )	Antenna Factor ( dB )	Cable Loss ( dB )	Preamp Factor ( dB )	Ant Pos ( cm )	Table Pos ( deg )	Remark
43.77	33.37	-6.63	40	52.8	11.55	0.72	31.7	-	-	Peak
73.74	33.84	-6.16	40	57.62	6.95	0.97	31.7	100	215	Peak
164.46	29.07	-14.43	43.5	49.14	10.03	1.53	31.63	-	-	Peak
514.9	22.26	-23.74	46	31.91	18.46	2.98	31.09	-	-	Peak
803.3	25.78	-20.22	46	30.37	22.25	3.86	30.7	-	-	Peak
939.8	26.81	-19.19	46	29.45	23.78	4.24	30.66	-	-	Peak
2386.38	51.39	-22.61	74	47.95	32.13	5.46	34.15	153	115	Peak
2386.38	41.16	-12.84	54	37.72	32.13	5.46	34.15	153	115	Average
2412	102.93	-	-	99.49	32.16	5.44	34.16	153	115	Peak
2412	101.46	-	-	98.02	32.16	5.44	34.16	153	115	Average
2500	35.04	-18.96	54	31.57	32.3	5.37	34.2	153	115	Average
2500	46.24	-27.76	74	42.77	32.3	5.37	34.2	153	115	Peak
8346	54.51	-19.49	74	43.54	36	10.07	35.1	100	342	Peak
8346	40.24	-13.76	54	29.27	36	10.07	35.1	100	342	Average



<b>Test Mode :</b>	Mode 2	<b>Temperature :</b>	22~23°C
<b>Test Channel :</b>	06	<b>Relative Humidity :</b>	42~43%
<b>Test Engineer :</b>	Kay Wu	<b>Polarization :</b>	Horizontal
<b>Remark :</b>	2437 MHz is Fundamental Signals which can be ignored.		

Frequency ( MHz )	Level ( dBuV/m )	Over Limit ( dB )	Limit Line ( dBuV/m )	Read Level ( dBuV )	Antenna Factor ( dB )	Cable Loss ( dB )	Preamp Factor ( dB )	Ant Pos ( cm )	Table Pos ( deg )	Remark
46.74	26.45	-13.55	40	47.45	9.94	0.76	31.7	100	55	Peak
73.74	22.13	-17.87	40	45.91	6.95	0.97	31.7	-	-	Peak
140.97	28.86	-14.64	43.5	47.46	11.65	1.41	31.66	-	-	Peak
399.4	22.62	-23.38	46	35.17	16.11	2.54	31.2	-	-	Peak
514.9	22.36	-23.64	46	32.01	18.46	2.98	31.09	-	-	Peak
914.6	27.04	-18.96	46	30.14	23.4	4.19	30.69	-	-	Peak
2356	48.17	-25.83	74	44.74	32.08	5.49	34.14	100	343	Peak
2356	35.55	-18.45	54	32.12	32.08	5.49	34.14	100	343	Average
2437	104.63	-	-	101.17	32.22	5.41	34.17	100	343	Peak
2437	99.65	-	-	96.19	32.22	5.41	34.17	100	343	Average
2486	34.23	-19.77	54	30.77	32.27	5.38	34.19	100	343	Average
2486	45.8	-28.2	74	42.34	32.27	5.38	34.19	100	343	Peak
8301	54.74	-19.26	74	43.8	36	10.04	35.1	100	167	Peak
8301	40.38	-13.62	54	29.44	36	10.04	35.1	100	167	Average



<b>Test Mode :</b>	Mode 2	<b>Temperature :</b>	22~23°C
<b>Test Channel :</b>	06	<b>Relative Humidity :</b>	42~43%
<b>Test Engineer :</b>	Kay Wu	<b>Polarization :</b>	Vertical
<b>Remark :</b>	2437 MHz is Fundamental Signals which can be ignored.		

Frequency ( MHz )	Level ( dBuV/m )	Over Limit ( dB )	Limit Line ( dBuV/m )	Read Level ( dBuV )	Antenna Factor ( dB )	Cable Loss ( dB )	Preamp Factor ( dB )	Ant Pos ( cm )	Table Pos ( deg )	Remark
43.5	33.42	-6.58	40	52.85	11.55	0.72	31.7	100	164	Peak
74.01	33.14	-6.86	40	56.92	6.95	0.97	31.7	-	-	Peak
107.22	29.37	-14.13	43.5	48.79	11.06	1.21	31.69	-	-	Peak
399.4	20.62	-25.38	46	33.17	16.11	2.54	31.2	-	-	Peak
466.6	22.44	-23.56	46	33.25	17.48	2.84	31.13	-	-	Peak
934.9	26.45	-19.55	46	29.18	23.71	4.23	30.67	-	-	Peak
2342	46.39	-27.61	74	42.98	32.05	5.5	34.14	148	238	Peak
2342	34.17	-19.83	54	30.76	32.05	5.5	34.14	148	238	Average
2437	103.99	-	-	100.53	32.22	5.41	34.17	148	238	Peak
2437	100	-	-	96.54	32.22	5.41	34.17	148	238	Average
2486	34.45	-19.55	54	30.99	32.27	5.38	34.19	148	238	Average
2486	46.7	-27.3	74	43.24	32.27	5.38	34.19	148	238	Peak
8361	54.15	-19.85	74	43.16	36	10.09	35.1	100	61	Peak
8361	40.26	-13.74	54	29.27	36	10.09	35.1	100	61	Average



<b>Test Mode :</b>	Mode 3	<b>Temperature :</b>	22~23°C
<b>Test Channel :</b>	11	<b>Relative Humidity :</b>	42~43%
<b>Test Engineer :</b>	Kay Wu	<b>Polarization :</b>	Horizontal
<b>Remark :</b>	2462 MHz is Fundamental Signals which can be ignored.		

Frequency ( MHz )	Level ( dBuV/m )	Over Limit ( dB )	Limit Line ( dBuV/m )	Read Level ( dBuV )	Antenna Factor ( dB )	Cable Loss ( dB )	Preamp Factor ( dB )	Ant Pos ( cm )	Table Pos ( deg )	Remark
46.74	25.72	-14.28	40	46.72	9.94	0.76	31.7	100	137	Peak
73.74	25.22	-14.78	40	49	6.95	0.97	31.7	-	-	Peak
142.05	25.83	-17.67	43.5	44.51	11.56	1.42	31.66	-	-	Peak
399.4	24.14	-21.86	46	36.69	16.11	2.54	31.2	-	-	Peak
466.6	22.56	-23.44	46	33.37	17.48	2.84	31.13	-	-	Peak
825.7	26.94	-19.06	46	31.27	22.46	3.91	30.7	-	-	Peak
2380	46.86	-27.14	74	43.43	32.11	5.47	34.15	101	48	Peak
2380	34.7	-19.3	54	31.27	32.11	5.47	34.15	101	48	Average
2462	105.11	-	-	101.65	32.24	5.4	34.18	101	48	Peak
2462	101.58	-	-	98.12	32.24	5.4	34.18	101	48	Average
2488.22	57.84	-16.16	74	54.36	32.3	5.37	34.19	101	48	Peak
2488.22	47.71	-6.29	54	44.23	32.3	5.37	34.19	101	48	Average
8397	54.25	-19.75	74	43.24	36	10.11	35.1	100	68	Peak
8397	40.35	-13.65	54	29.34	36	10.11	35.1	100	68	Average



Test Mode :	Mode 3	Temperature :	22~23°C
Test Channel :	11	Relative Humidity :	42~43%
Test Engineer :	Kay Wu	Polarization :	Vertical
Remark :	2462 MHz is Fundamental Signals which can be ignored.		

Frequency ( MHz )	Level ( dBuV/m )	Over Limit ( dB )	Limit Line ( dBuV/m )	Read Level ( dBuV )	Antenna Factor ( dB )	Cable Loss ( dB )	Preamp Factor ( dB )	Ant Pos ( cm )	Table Pos ( deg )	Remark
43.77	33.01	-6.99	40	52.44	11.55	0.72	31.7	-	-	Peak
74.01	33.87	-6.13	40	57.65	6.95	0.97	31.7	100	66	Peak
165.81	28.91	-14.59	43.5	49.05	9.96	1.53	31.63	-	-	Peak
542.2	20.43	-25.57	46	29.45	18.97	3.07	31.06	-	-	Peak
668.9	23.9	-22.1	46	30.77	20.6	3.46	30.93	-	-	Peak
834.1	27.6	-18.4	46	31.82	22.55	3.93	30.7	-	-	Peak
2364	46.78	-27.22	74	43.35	32.08	5.49	34.14	120	104	Peak
2364	33.5	-20.5	54	30.07	32.08	5.49	34.14	120	104	Average
2462	105.08	-	-	101.62	32.24	5.4	34.18	120	104	Peak
2462	101.47	-	-	98.01	32.24	5.4	34.18	120	104	Average
2488.22	56.4	-17.6	74	52.92	32.3	5.37	34.19	120	104	Peak
2488.22	46.98	-7.02	54	43.5	32.3	5.37	34.19	120	104	Average
8298	54.49	-19.51	74	43.55	36	10.04	35.1	100	155	Peak
8298	40.82	-13.18	54	29.88	36	10.04	35.1	100	155	Average





<b>Test Mode :</b>	Mode 4	<b>Temperature :</b>	22~23°C
<b>Test Channel :</b>	12	<b>Relative Humidity :</b>	42~43%
<b>Test Engineer :</b>	Kay Wu	<b>Polarization :</b>	Horizontal
<b>Remark :</b>	2467 MHz is Fundamental Signals which can be ignored.		

Frequency ( MHz )	Level ( dBuV/m )	Over Limit ( dB )	Limit Line ( dBuV/m )	Read Level (dBuV)	Antenna Factor ( dB )	Cable Loss ( dB )	Preamp Factor ( dB )	Ant Pos ( cm )	Table Pos ( deg )	Remark
2364	46.03	-27.97	74	42.6	32.08	5.49	34.14	101	47	Peak
2364	33.64	-20.36	54	30.21	32.08	5.49	34.14	101	47	Average
2467	101.24	-	-	97.78	32.24	5.4	34.18	101	47	Peak
2467	97.14	-	-	93.68	32.24	5.4	34.18	101	47	Average
2483.5	57.43	-16.57	74	53.97	32.27	5.38	34.19	101	47	Peak
2483.5	47.39	-6.61	54	43.93	32.27	5.38	34.19	101	47	Average



Test Mode :	Mode 4	Temperature :	22~23°C
Test Channel :	12	Relative Humidity :	42~43%
Test Engineer :	Kay Wu	Polarization :	Vertical
Remark :	2467 MHz is Fundamental Signals which can be ignored.		

Frequency ( MHz )	Level ( dBuV/m )	Over Limit ( dB )	Limit Line ( dBuV/m )	Read Level (dBuV)	Antenna Factor ( dB )	Cable Loss ( dB )	Preamp Factor ( dB )	Ant Pos ( cm )	Table Pos ( deg )	Remark
2380	45.47	-28.53	74	42.04	32.11	5.47	34.15	137	288	Peak
2380	33.52	-20.48	54	30.09	32.11	5.47	34.15	137	288	Average
2467	100.74	-	-	97.28	32.24	5.4	34.18	137	288	Peak
2467	96.5	-	-	93.04	32.24	5.4	34.18	137	288	Average
2483.66	55.26	-18.74	74	51.8	32.27	5.38	34.19	137	288	Peak
2483.66	46.32	-7.68	54	42.86	32.27	5.38	34.19	137	288	Average



Test Mode :	Mode 5	Temperature :	22~23°C
Test Channel :	13	Relative Humidity :	42~43%
Test Engineer :	Kay Wu	Polarization :	Horizontal
Remark :	2472 MHz is Fundamental Signals which can be ignored.		

Frequency ( MHz )	Level ( dBuV/m )	Over Limit ( dB )	Limit Line ( dBuV/m )	Read Level ( dBuV )	Antenna Factor ( dB )	Cable Loss ( dB )	Preamp Factor ( dB )	Ant Pos ( cm )	Table Pos ( deg )	Remark
2326	46.2	-27.8	74	42.8	32.02	5.51	34.13	100	54	Peak
2326	32.51	-21.49	54	29.11	32.02	5.51	34.13	100	54	Average
2472	93.85	-	-	90.39	32.27	5.38	34.19	100	54	Peak
2472	89.67	-	-	86.21	32.27	5.38	34.19	100	54	Average
2483.5	54.92	-19.08	74	51.46	32.27	5.38	34.19	100	54	Peak
2483.5	46.31	-7.69	54	42.85	32.27	5.38	34.19	100	54	Average



<b>Test Mode :</b>	Mode 5	<b>Temperature :</b>	22~23°C
<b>Test Channel :</b>	13	<b>Relative Humidity :</b>	42~43%
<b>Test Engineer :</b>	Kay Wu	<b>Polarization :</b>	Vertical
<b>Remark :</b>	2472 MHz is Fundamental Signals which can be ignored.		

Frequency ( MHz )	Level ( dBuV/m )	Over Limit ( dB )	Limit Line ( dBuV/m )	Read Level (dBuV)	Antenna Factor ( dB )	Cable Loss ( dB )	Preamp Factor ( dB )	Ant Pos ( cm )	Table Pos ( deg )	Remark
2334	45.62	-28.38	74	42.22	32.02	5.51	34.13	154	129	Peak
2334	32.85	-21.15	54	29.45	32.02	5.51	34.13	154	129	Average
2472	93.14	-	-	89.68	32.27	5.38	34.19	154	129	Peak
2472	88.84	-	-	85.38	32.27	5.38	34.19	154	129	Average
2483.5	54.65	-19.35	74	51.19	32.27	5.38	34.19	154	129	Peak
2483.5	45.8	-8.2	54	42.34	32.27	5.38	34.19	154	129	Average



<b>Test Mode :</b>	Mode 6	<b>Temperature :</b>	22~23°C
<b>Test Channel :</b>	01	<b>Relative Humidity :</b>	42~43%
<b>Test Engineer :</b>	Kay Wu	<b>Polarization :</b>	Horizontal
<b>Remark :</b>	2412 MHz is Fundamental Signals which can be ignored.		

Frequency ( MHz )	Level ( dBuV/m )	Over Limit ( dB )	Limit Line ( dBuV/m )	Read Level ( dBuV )	Antenna Factor ( dB )	Cable Loss ( dB )	Preamp Factor ( dB )	Ant Pos ( cm )	Table Pos ( deg )	Remark
47.82	27.28	-12.72	40	48.76	9.45	0.77	31.7	100	164	Peak
74.82	22.61	-17.39	40	46.29	7.04	0.98	31.7	-	-	Peak
145.29	25.81	-17.69	43.5	44.59	11.43	1.44	31.65	-	-	Peak
318.9	21.6	-24.4	46	36.78	13.97	2.21	31.36	-	-	Peak
399.4	25.05	-20.95	46	37.6	16.11	2.54	31.2	-	-	Peak
942.6	26.72	-19.28	46	29.3	23.83	4.25	30.66	-	-	Peak
2389.61	45.53	-8.47	54	42.09	32.13	5.46	34.15	100	57	Average
2389.61	67.27	-6.73	74	63.83	32.13	5.46	34.15	100	57	Peak
2412	91.28	-	-	87.84	32.16	5.44	34.16	100	57	Average
2412	105.11	-	-	101.66	32.19	5.43	34.17	100	57	Peak
2486	48.26	-25.74	74	44.8	32.27	5.38	34.19	100	57	Peak
2486	35.81	-18.19	54	32.35	32.27	5.38	34.19	100	57	Average
8313	55.44	-18.56	74	44.49	36	10.05	35.1	100	88	Peak
8313	40.61	-13.39	54	29.66	36	10.05	35.1	100	88	Average



Test Mode :	Mode 6	Temperature :	22~23°C
Test Channel :	01	Relative Humidity :	42~43%
Test Engineer :	Kay Wu	Polarization :	Vertical
Remark :	2412 MHz is Fundamental Signals which can be ignored.		

Frequency ( MHz )	Level ( dBuV/m )	Over Limit ( dB )	Limit Line ( dBuV/m )	Read Level ( dBuV )	Antenna Factor ( dB )	Cable Loss ( dB )	Preamp Factor ( dB )	Ant Pos ( cm )	Table Pos ( deg )	Remark
44.58	32.81	-7.19	40	52.87	10.92	0.72	31.7	-	-	Peak
73.74	33.86	-6.14	40	57.64	6.95	0.97	31.7	100	133	Peak
163.65	29.18	-14.32	43.5	49.19	10.1	1.53	31.64	-	-	Peak
466.6	21.7	-24.3	46	32.51	17.48	2.84	31.13	-	-	Peak
780.9	24.38	-21.62	46	29.38	21.95	3.79	30.74	-	-	Peak
934.2	26.75	-19.25	46	29.5	23.69	4.23	30.67	-	-	Peak
2389.61	40.06	-13.94	54	36.62	32.13	5.46	34.15	126	349	Average
2389.61	59.86	-14.14	74	56.42	32.13	5.46	34.15	126	349	Peak
2412	88.04	-	-	84.6	32.16	5.44	34.16	126	349	Average
2412	101.75	-	-	98.3	32.19	5.43	34.17	126	349	Peak
2494	46.22	-27.78	74	42.75	32.3	5.37	34.2	126	349	Peak
2494	34.1	-19.9	54	30.63	32.3	5.37	34.2	126	349	Average
8430	54.27	-19.73	74	43.24	36	10.13	35.1	100	58	Peak
8430	40.91	-13.09	54	29.88	36	10.13	35.1	100	58	Average



<b>Test Mode :</b>	Mode 7	<b>Temperature :</b>	22~23°C
<b>Test Channel :</b>	02	<b>Relative Humidity :</b>	42~43%
<b>Test Engineer :</b>	Kay Wu	<b>Polarization :</b>	Horizontal
<b>Remark :</b>	2417 MHz is Fundamental Signals which can be ignored.		

Frequency ( MHz )	Level ( dBuV/m )	Over Limit ( dB )	Limit Line ( dBuV/m )	Read Level ( dBuV )	Antenna Factor ( dB )	Cable Loss ( dB )	Preamp Factor ( dB )	Ant Pos ( cm )	Table Pos ( deg )	Remark
2389.42	42.33	-11.67	54	38.89	32.13	5.46	34.15	100	54	Average
2389.42	64.06	-9.94	74	60.62	32.13	5.46	34.15	100	54	Peak
2417	93.46	-	-	90.03	32.16	5.44	34.17	100	54	Average
2417	106.36	-	-	102.91	32.19	5.43	34.17	100	54	Peak
2484	47.7	-26.3	74	44.24	32.27	5.38	34.19	100	54	Peak
2484	35.54	-18.46	54	32.08	32.27	5.38	34.19	100	54	Average



<b>Test Mode :</b>	Mode 7	<b>Temperature :</b>	22~23°C
<b>Test Channel :</b>	02	<b>Relative Humidity :</b>	42~43%
<b>Test Engineer :</b>	Kay Wu	<b>Polarization :</b>	Vertical
<b>Remark :</b>	2417 MHz is Fundamental Signals which can be ignored.		

Frequency ( MHz )	Level ( dBuV/m )	Over Limit ( dB )	Limit Line ( dBuV/m )	Read Level (dBuV)	Antenna Factor ( dB )	Cable Loss ( dB )	Preamp Factor ( dB )	Ant Pos ( cm )	Table Pos ( deg )	Remark
2389.99	40.3	-13.7	54	36.87	32.13	5.46	34.16	100	243	Average
2389.99	60.98	-13.02	74	57.55	32.13	5.46	34.16	100	243	Peak
2417	89.82	-	-	86.39	32.16	5.44	34.17	100	243	Average
2417	103.19	-	-	99.74	32.19	5.43	34.17	100	243	Peak
2500	45.34	-28.66	74	41.87	32.3	5.37	34.2	100	243	Peak
2500	33.14	-20.86	54	29.67	32.3	5.37	34.2	100	243	Average





<b>Test Mode :</b>	Mode 8	<b>Temperature :</b>	22~23°C
<b>Test Channel :</b>	06	<b>Relative Humidity :</b>	42~43%
<b>Test Engineer :</b>	Kay Wu	<b>Polarization :</b>	Horizontal
<b>Remark :</b>	2437 MHz is Fundamental Signals which can be ignored.		

Frequency ( MHz )	Level ( dBuV/m )	Over Limit ( dB )	Limit Line ( dBuV/m )	Read Level ( dBuV )	Antenna Factor ( dB )	Cable Loss ( dB )	Preamp Factor ( dB )	Ant Pos ( cm )	Table Pos ( deg )	Remark
45.93	25	-15	40	45.53	10.43	0.74	31.7	100	162	Peak
74.82	19.28	-20.72	40	42.96	7.04	0.98	31.7	-	-	Peak
145.02	25.26	-18.24	43.5	44.04	11.43	1.44	31.65	-	-	Peak
318.2	22.01	-23.99	46	37.21	13.95	2.21	31.36	-	-	Peak
399.4	24.4	-21.6	46	36.95	16.11	2.54	31.2	-	-	Peak
957.3	26.71	-19.29	46	29.03	24.04	4.28	30.64	-	-	Peak
2390	62.07	-11.93	74	58.64	32.13	5.46	34.16	100	342	Peak
2390	41.06	-12.94	54	37.63	32.13	5.46	34.16	100	342	Average
2437	108.64	-	-	105.19	32.22	5.41	34.18	100	342	Peak
2437	94.58	-	-	91.12	32.22	5.41	34.17	100	342	Average
2484	40.03	-13.97	54	36.57	32.27	5.38	34.19	100	342	Average
2484	61.12	-12.88	74	57.66	32.27	5.38	34.19	100	342	Peak
8418	54.27	-19.73	74	43.25	36	10.12	35.1	100	61	Peak
8418	40.35	-13.65	54	29.33	36	10.12	35.1	100	61	Average



Test Mode :	Mode 8	Temperature :	22~23°C
Test Channel :	06	Relative Humidity :	42~43%
Test Engineer :	Kay Wu	Polarization :	Vertical
Remark :	2437 MHz is Fundamental Signals which can be ignored.		

Frequency ( MHz )	Level ( dBuV/m )	Over Limit ( dB )	Limit Line ( dBuV/m )	Read Level ( dBuV )	Antenna Factor ( dB )	Cable Loss ( dB )	Preamp Factor ( dB )	Ant Pos ( cm )	Table Pos ( deg )	Remark
42.69	32.89	-7.11	40	51.69	12.18	0.72	31.7	-	-	Peak
74.28	33.68	-6.32	40	57.36	7.04	0.98	31.7	100	58	Peak
164.73	28.39	-15.11	43.5	48.46	10.03	1.53	31.63	-	-	Peak
466.6	21.54	-24.46	46	32.35	17.48	2.84	31.13	-	-	Peak
834.8	26.16	-19.84	46	30.37	22.56	3.93	30.7	-	-	Peak
953.8	26.55	-19.45	46	28.94	23.99	4.27	30.65	-	-	Peak
2390	60.27	-13.73	74	56.84	32.13	5.46	34.16	128	121	Peak
2390	41.6	-12.4	54	38.17	32.13	5.46	34.16	128	121	Average
2437	95.98	-	-	92.52	32.22	5.41	34.17	128	121	Average
2437	108.03	-	-	104.57	32.22	5.41	34.17	128	121	Peak
2484	61.59	-12.41	74	58.13	32.27	5.38	34.19	128	121	Peak
2484	41.04	-12.96	54	37.58	32.27	5.38	34.19	128	121	Average
8262	54.17	-19.83	74	43.25	36	10.02	35.1	100	58	Peak
8262	40.6	-13.4	54	29.68	36	10.02	35.1	100	58	Average



<b>Test Mode :</b>	Mode 9	<b>Temperature :</b>	22~23°C
<b>Test Channel :</b>	10	<b>Relative Humidity :</b>	42~43%
<b>Test Engineer :</b>	Kay Wu	<b>Polarization :</b>	Horizontal
<b>Remark :</b>	2457 MHz is Fundamental Signals which can be ignored.		

Frequency ( MHz )	Level ( dBuV/m )	Over Limit ( dB )	Limit Line ( dBuV/m )	Read Level (dBuV)	Antenna Factor ( dB )	Cable Loss ( dB )	Preamp Factor ( dB )	Ant Pos ( cm )	Table Pos ( deg )	Remark
2374	48.2	-25.8	74	44.77	32.11	5.47	34.15	123	63	Peak
2374	35.72	-18.28	54	32.29	32.11	5.47	34.15	123	63	Average
2457	108.04	-	-	104.59	32.22	5.41	34.18	123	23	Peak
2457	93.75	-	-	90.29	32.24	5.4	34.18	123	63	Average
2483.66	67.9	-6.1	74	64.44	32.27	5.38	34.19	123	63	Peak
2483.66	46.53	-7.47	54	43.07	32.27	5.38	34.19	123	63	Average



<b>Test Mode :</b>	Mode 9	<b>Temperature :</b>	22~23°C
<b>Test Channel :</b>	10	<b>Relative Humidity :</b>	42~43%
<b>Test Engineer :</b>	Kay Wu	<b>Polarization :</b>	Vertical
<b>Remark :</b>	2457 MHz is Fundamental Signals which can be ignored.		

Frequency ( MHz )	Level ( dBuV/m )	Over Limit ( dB )	Limit Line ( dBuV/m )	Read Level (dBuV)	Antenna Factor ( dB )	Cable Loss ( dB )	Preamp Factor ( dB )	Ant Pos ( cm )	Table Pos ( deg )	Remark
2374	47.67	-26.33	74	44.24	32.11	5.47	34.15	103	280	Peak
2374	35.89	-18.11	54	32.46	32.11	5.47	34.15	103	280	Average
2457	109.38	-	-	105.92	32.24	5.4	34.18	103	280	Peak
2457	94.42	-	-	90.96	32.24	5.4	34.18	103	280	Average
2484.61	66.7	-7.3	74	63.24	32.27	5.38	34.19	103	280	Peak
2484.61	44.44	-9.56	54	40.98	32.27	5.38	34.19	103	280	Average



Test Mode :	Mode 10	Temperature :	22~23°C
Test Channel :	11	Relative Humidity :	42~43%
Test Engineer :	Kay Wu	Polarization :	Horizontal
Remark :	2462 MHz is Fundamental Signals which can be ignored.		

Frequency ( MHz )	Level ( dBuV/m )	Over Limit ( dB )	Limit Line ( dBuV/m )	Read Level ( dBuV )	Antenna Factor ( dB )	Cable Loss ( dB )	Preamp Factor ( dB )	Ant Pos ( cm )	Table Pos ( deg )	Remark
45.93	25.26	-14.74	40	45.79	10.43	0.74	31.7	100	155	Peak
74.01	20.1	-19.9	40	43.88	6.95	0.97	31.7	-	-	Peak
143.13	25.56	-17.94	43.5	44.27	11.52	1.43	31.66	-	-	Peak
399.4	23.83	-22.17	46	36.38	16.11	2.54	31.2	-	-	Peak
693.4	22.76	-23.24	46	29.35	20.79	3.53	30.91	-	-	Peak
934.2	26.51	-19.49	46	29.26	23.69	4.23	30.67	-	-	Peak
2374	48.58	-25.42	74	45.15	32.11	5.47	34.15	100	59	Peak
2374	36.29	-17.71	54	32.86	32.11	5.47	34.15	100	59	Average
2462	105.63	-	-	102.17	32.24	5.4	34.18	100	59	Peak
2462	92.12	-	-	88.66	32.24	5.4	34.18	100	59	Average
2483.5	67.26	-6.74	74	63.8	32.27	5.38	34.19	100	59	Peak
2483.5	45.9	-8.1	54	42.44	32.27	5.38	34.19	100	59	Average
8457	54.13	-19.87	74	43.07	36	10.16	35.1	100	285	Peak
8457	40.43	-13.57	54	29.37	36	10.16	35.1	100	285	Average



<b>Test Mode :</b>	Mode 10	<b>Temperature :</b>	22~23°C
<b>Test Channel :</b>	11	<b>Relative Humidity :</b>	42~43%
<b>Test Engineer :</b>	Kay Wu	<b>Polarization :</b>	Vertical
<b>Remark :</b>	2462 MHz is Fundamental Signals which can be ignored.		

Frequency ( MHz )	Level ( dBuV/m )	Over Limit ( dB )	Limit Line ( dBuV/m )	Read Level ( dBuV )	Antenna Factor ( dB )	Cable Loss ( dB )	Preamp Factor ( dB )	Ant Pos ( cm )	Table Pos ( deg )	Remark
44.58	30.04	-9.96	40	50.1	10.92	0.72	31.7	-	-	Peak
73.74	33.05	-6.95	40	56.83	6.95	0.97	31.7	100	196	Peak
140.97	23.35	-20.15	43.5	41.95	11.65	1.41	31.66	-	-	Peak
466.6	22.8	-23.2	46	33.61	17.48	2.84	31.13	-	-	Peak
687.8	22.93	-23.07	46	29.59	20.74	3.51	30.91	-	-	Peak
920.2	26.84	-19.16	46	29.83	23.49	4.2	30.68	-	-	Peak
2372	48.8	-25.2	74	45.37	32.11	5.47	34.15	103	282	Peak
2372	36	-18	54	32.57	32.11	5.47	34.15	103	282	Average
2462	105.52	-	-	102.06	32.24	5.4	34.18	103	281	Peak
2462	92.71	-	-	89.25	32.24	5.4	34.18	103	282	Average
2483.5	66.48	-7.52	74	63.02	32.27	5.38	34.19	103	282	Peak
2483.5	45.09	-8.91	54	41.63	32.27	5.38	34.19	103	282	Average
8178	54.49	-19.51	74	43.63	36	9.96	35.1	100	62	Peak
8178	40.17	-13.83	54	29.31	36	9.96	35.1	100	62	Average



<b>Test Mode :</b>	Mode 11	<b>Temperature :</b>	22~23°C
<b>Test Channel :</b>	12	<b>Relative Humidity :</b>	42~43%
<b>Test Engineer :</b>	Kay Wu	<b>Polarization :</b>	Horizontal
<b>Remark :</b>	2467 MHz is Fundamental Signals which can be ignored.		

Frequency ( MHz )	Level ( dBuV/m )	Over Limit ( dB )	Limit Line ( dBuV/m )	Read Level (dBuV)	Antenna Factor ( dB )	Cable Loss ( dB )	Preamp Factor ( dB )	Ant Pos ( cm )	Table Pos ( deg )	Remark
2390	46.48	-27.52	74	43.05	32.13	5.46	34.16	122	63	Peak
2390	33.73	-20.27	54	30.3	32.13	5.46	34.16	122	63	Average
2467	99.53	-	-	96.07	32.27	5.38	34.19	122	63	Peak
2467	86.45	-	-	83	32.24	5.4	34.19	122	63	Average
2483.66	67.64	-6.36	74	64.18	32.27	5.38	34.19	122	63	Peak
2483.66	42.8	-11.2	54	39.34	32.27	5.38	34.19	122	63	Average



<b>Test Mode :</b>	Mode 11	<b>Temperature :</b>	22~23°C
<b>Test Channel :</b>	12	<b>Relative Humidity :</b>	42~43%
<b>Test Engineer :</b>	Kay Wu	<b>Polarization :</b>	Vertical
<b>Remark :</b>	2467 MHz is Fundamental Signals which can be ignored.		

Frequency ( MHz )	Level ( dBuV/m )	Over Limit ( dB )	Limit Line ( dBuV/m )	Read Level (dBuV)	Antenna Factor ( dB )	Cable Loss ( dB )	Preamp Factor ( dB )	Ant Pos ( cm )	Table Pos ( deg )	Remark
2374	45.58	-28.42	74	42.15	32.11	5.47	34.15	103	281	Peak
2374	33.93	-20.07	54	30.5	32.11	5.47	34.15	103	281	Average
2467	99.14	-	-	95.68	32.24	5.4	34.18	102	281	Peak
2467	85.87	-	-	82.42	32.24	5.4	34.19	103	281	Average
2483.66	65.83	-8.17	74	62.37	32.27	5.38	34.19	103	281	Peak
2483.66	42.08	-11.92	54	38.62	32.27	5.38	34.19	103	281	Average





<b>Test Mode :</b>	Mode 12	<b>Temperature :</b>	22~23°C
<b>Test Channel :</b>	13	<b>Relative Humidity :</b>	42~43%
<b>Test Engineer :</b>	Kay Wu	<b>Polarization :</b>	Horizontal
<b>Remark :</b>	2472 MHz is Fundamental Signals which can be ignored.		

Frequency ( MHz )	Level ( dBuV/m )	Over Limit ( dB )	Limit Line ( dBuV/m )	Read Level (dBuV)	Antenna Factor ( dB )	Cable Loss ( dB )	Preamp Factor ( dB )	Ant Pos ( cm )	Table Pos ( deg )	Remark
2316	46.04	-27.96	74	42.64	32	5.53	34.13	102	62	Peak
2316	31.85	-22.15	54	28.45	32	5.53	34.13	102	62	Average
2472	69.94	-	-	66.49	32.24	5.4	34.19	102	62	Peak
2472	59.09	-	-	55.63	32.27	5.38	34.19	102	62	Average
2483.85	47.96	-26.04	74	44.5	32.27	5.38	34.19	102	62	Peak
2483.85	32.75	-21.25	54	29.29	32.27	5.38	34.19	102	62	Average



Test Mode :	Mode 12	Temperature :	22~23°C
Test Channel :	13	Relative Humidity :	42~43%
Test Engineer :	Kay Wu	Polarization :	Vertical
Remark :	2472 MHz is Fundamental Signals which can be ignored.		

Frequency ( MHz )	Level ( dBuV/m )	Over Limit ( dB )	Limit Line ( dBuV/m )	Read Level (dBuV)	Antenna Factor ( dB )	Cable Loss ( dB )	Preamp Factor ( dB )	Ant Pos ( cm )	Table Pos ( deg )	Remark
2316	45.67	-28.33	74	42.27	32	5.53	34.13	152	138	Peak
2316	31.8	-22.2	54	28.4	32	5.53	34.13	152	138	Average
2472	69.49	-	-	66.04	32.24	5.4	34.19	152	138	Peak
2472	58.8	-	-	55.34	32.27	5.38	34.19	152	138	Average
2483.85	50.35	-23.65	74	46.89	32.27	5.38	34.19	152	138	Peak
2483.85	33.17	-20.83	54	29.71	32.27	5.38	34.19	152	138	Average



<b>Test Mode :</b>	Mode 13	<b>Temperature :</b>	22~23°C
<b>Test Channel :</b>	11	<b>Relative Humidity :</b>	42~43%
<b>Test Engineer :</b>	Kay Wu	<b>Polarization :</b>	Horizontal
<b>Remark :</b>	2462 MHz is Fundamental Signals which can be ignored.		

Frequency ( MHz )	Level ( dBuV/m )	Over Limit ( dB )	Limit Line ( dBuV/m )	Read Level ( dBuV )	Antenna Factor ( dB )	Cable Loss ( dB )	Preamp Factor ( dB )	Ant Pos ( cm )	Table Pos ( deg )	Remark
30	23.5	-16.5	40	35.05	19.51	0.64	31.7	152	33	Peak
123.69	22.62	-20.88	43.5	41.07	11.89	1.34	31.68	-	-	Peak
182.82	23.5	-20	43.5	44.49	9	1.63	31.62	-	-	Peak
399.4	27.1	-18.9	46	39.65	16.11	2.54	31.2	-	-	Peak
564.6	22.98	-23.02	46	31.49	19.39	3.14	31.04	-	-	Peak
805.4	25.42	-20.58	46	29.99	22.27	3.86	30.7	-	-	Peak
2390	45.93	-28.07	74	42.5	32.13	5.46	34.16	117	33	Peak
2390	33.88	-20.12	54	30.45	32.13	5.46	34.16	117	33	Average
2462	96.03	-	-	92.57	32.24	5.4	34.18	117	33	Peak
2462	84.48	-	-	81.02	32.24	5.4	34.18	117	33	Average
2484.42	59.88	-14.12	74	56.42	32.27	5.38	34.19	117	33	Peak
2484.42	38.62	-15.38	54	35.16	32.27	5.38	34.19	117	33	Average
8289	54.2	-19.8	74	43.26	36	10.04	35.1	100	254	Peak
8289	38.83	-15.17	54	27.89	36	10.04	35.1	100	254	Average



<b>Test Mode :</b>	Mode 13	<b>Temperature :</b>	22~23°C
<b>Test Channel :</b>	11	<b>Relative Humidity :</b>	42~43%
<b>Test Engineer :</b>	Kay Wu	<b>Polarization :</b>	Vertical
<b>Remark :</b>	2462 MHz is Fundamental Signals which can be ignored.		

Frequency ( MHz )	Level ( dBuV/m )	Over Limit ( dB )	Limit Line ( dBuV/m )	Read Level ( dBuV )	Antenna Factor ( dB )	Cable Loss ( dB )	Preamp Factor ( dB )	Ant Pos ( cm )	Table Pos ( deg )	Remark
43.77	27.77	-12.23	40	47.2	11.55	0.72	31.7	100	224	Peak
78.33	26.89	-13.11	40	50.21	7.39	0.99	31.7	-	-	Peak
140.7	25.42	-18.08	43.5	44.02	11.65	1.41	31.66	-	-	Peak
341.3	20.38	-25.62	46	34.82	14.57	2.31	31.32	-	-	Peak
531	25.41	-20.59	46	34.7	18.75	3.03	31.07	-	-	Peak
777.4	24.56	-21.44	46	29.61	21.91	3.78	30.74	-	-	Peak
2310	45.57	-28.43	74	42.16	32	5.53	34.12	153	189	Peak
2310	32.56	-21.44	54	29.15	32	5.53	34.12	153	189	Average
2462	90.89	-	-	87.43	32.24	5.4	34.18	153	189	Peak
2462	80.4	-	-	76.94	32.24	5.4	34.18	153	189	Average
2484.61	53.64	-20.36	74	50.18	32.27	5.38	34.19	153	189	Peak
2484.61	35.04	-18.96	54	31.58	32.27	5.38	34.19	153	189	Average
8370	54.53	-19.47	74	43.53	36	10.1	35.1	100	154	Peak
8370	39.52	-14.48	54	28.52	36	10.1	35.1	100	154	Average



<b>Test Mode :</b>	Mode 14	<b>Temperature :</b>	22~23°C
<b>Test Channel :</b>	149	<b>Relative Humidity :</b>	42~43%
<b>Test Engineer :</b>	Kay Wu	<b>Polarization :</b>	Horizontal
<b>Remark :</b>	1. 5745 MHz is Fundamental Signals which can be ignored. 2. 17235 MHz is not within a restricted band.		

Frequency ( MHz )	Level ( dBuV/m )	Over Limit ( dB )	Limit Line ( dBuV/m )	Read Level ( dBuV )	Antenna Factor ( dB )	Cable Loss ( dB )	Preamp Factor ( dB )	Ant Pos ( cm )	Table Pos ( deg )	Remark
30	22.8	-17.2	40	34.35	19.51	0.64	31.7	100	67	Peak
73.74	20.08	-19.92	40	43.86	6.95	0.97	31.7	-	-	Peak
172.02	21.67	-21.83	43.5	42.21	9.53	1.56	31.63	-	-	Peak
399.4	23.76	-22.24	46	36.31	16.11	2.54	31.2	-	-	Peak
466.6	22.81	-23.19	46	33.62	17.48	2.84	31.13	-	-	Peak
929.3	27.35	-18.65	46	30.18	23.62	4.22	30.67	-	-	Peak
5745	106.33	-	-	97.38	35.04	8.41	34.5	100	303	Peak
5745	94.02	-	-	85.07	35.04	8.41	34.5	100	303	Average
8422	53.98	-20.02	74	42.95	36	10.13	35.1	100	157	Peak
8422	40.34	-13.66	54	29.31	36	10.13	35.1	100	157	Average
11490	49.35	-24.65	74	84.03	-11.73	11.65	34.6	100	324	Peak
11490	37.53	-16.47	54	72.21	-11.73	11.65	34.6	100	324	Average
17235	58.59	-27.74	86.33	89.09	-11.07	14.83	34.26	100	0	Peak



<b>Test Mode :</b>	Mode 14	<b>Temperature :</b>	22~23°C
<b>Test Channel :</b>	149	<b>Relative Humidity :</b>	42~43%
<b>Test Engineer :</b>	Kay Wu	<b>Polarization :</b>	Vertical
<b>Remark :</b>	1. 5745 MHz is Fundamental Signals which can be ignored. 2. 17235 MHz is not within a restricted band.		

Frequency ( MHz )	Level ( dBuV/m )	Over Limit ( dB )	Limit Line ( dBuV/m )	Read Level ( dBuV )	Antenna Factor ( dB )	Cable Loss ( dB )	Preamp Factor ( dB )	Ant Pos ( cm )	Table Pos ( deg )	Remark
51.06	28.86	-11.14	40	51.95	7.77	0.84	31.7	-	-	Peak
74.01	30.29	-9.71	40	54.07	6.95	0.97	31.7	100	157	Peak
165.81	27.57	-15.93	43.5	47.71	9.96	1.53	31.63	-	-	Peak
564.6	22.21	-23.79	46	30.72	19.39	3.14	31.04	-	-	Peak
691.3	22.63	-23.37	46	29.24	20.77	3.53	30.91	-	-	Peak
932.1	26.48	-19.52	46	29.27	23.66	4.22	30.67	-	-	Peak
5745	104.45	-	-	95.5	35.04	8.41	34.5	100	254	Peak
5745	92.75	-	-	83.8	35.04	8.41	34.5	100	254	Average
8446	54.02	-19.98	74	42.98	36	10.14	35.1	100	228	Peak
8446	40.15	-13.85	54	29.11	36	10.14	35.1	100	228	Average
11490	48.09	-25.91	74	82.77	-11.73	11.65	34.6	100	203	Peak
11490	35	-19	54	69.68	-11.73	11.65	34.6	100	203	Average
17235	53.78	-30.67	84.45	84.28	-11.07	14.83	34.26	100	0	Peak



<b>Test Mode :</b>	Mode 15	<b>Temperature :</b>	22~23°C
<b>Test Channel :</b>	157	<b>Relative Humidity :</b>	42~43%
<b>Test Engineer :</b>	Kay Wu	<b>Polarization :</b>	Horizontal
<b>Remark :</b>	1. 5785 MHz is Fundamental Signals which can be ignored. 2. 17355 MHz is not within a restricted band.		

Frequency ( MHz )	Level ( dBuV/m )	Over Limit ( dB )	Limit Line ( dBuV/m )	Read Level ( dBuV )	Antenna Factor ( dB )	Cable Loss ( dB )	Preamp Factor ( dB )	Ant Pos ( cm )	Table Pos ( deg )	Remark
37.29	22.79	-17.21	40	38.65	15.13	0.71	31.7	100	57	Peak
45.93	20.84	-19.16	40	41.37	10.43	0.74	31.7	-	-	Peak
152.85	21.88	-21.62	43.5	41.1	10.95	1.48	31.65	-	-	Peak
399.4	24.36	-21.64	46	36.91	16.11	2.54	31.2	-	-	Peak
763.4	23.74	-22.26	46	29.06	21.71	3.74	30.77	-	-	Peak
937.7	26.6	-19.4	46	29.27	23.75	4.24	30.66	-	-	Peak
5785	106.49	-	-	97.49	35.09	8.42	34.51	100	303	Peak
5785	94.84	-	-	85.85	35.09	8.42	34.52	100	303	Average
8454	54.46	-19.54	74	43.42	36	10.14	35.1	100	66	Peak
8454	40.05	-13.95	54	29.01	36	10.14	35.1	100	66	Average
11570	51.26	-22.74	74	85.69	-11.49	11.69	34.63	100	304	Peak
11570	37.79	-16.21	54	72.22	-11.49	11.69	34.63	100	304	Average
17355	60.6	-25.89	86.49	91.44	-11.61	15	34.23	100	0	Peak



<b>Test Mode :</b>	Mode 15	<b>Temperature :</b>	22~23°C
<b>Test Channel :</b>	157	<b>Relative Humidity :</b>	42~43%
<b>Test Engineer :</b>	Kay Wu	<b>Polarization :</b>	Vertical
<b>Remark :</b>	1. 5785 MHz is Fundamental Signals which can be ignored. 2. 17355 MHz is not within a restricted band.		

Frequency ( MHz )	Level ( dBuV/m )	Over Limit ( dB )	Limit Line ( dBuV/m )	Read Level ( dBuV )	Antenna Factor ( dB )	Cable Loss ( dB )	Preamp Factor ( dB )	Ant Pos ( cm )	Table Pos ( deg )	Remark
41.61	29.36	-10.64	40	47.53	12.8	0.73	31.7	-	-	Peak
74.82	30.99	-9.01	40	54.67	7.04	0.98	31.7	100	89	Peak
164.73	27.94	-15.56	43.5	48.01	10.03	1.53	31.63	-	-	Peak
310.5	19.98	-26.02	46	35.44	13.74	2.18	31.38	-	-	Peak
466.6	22.64	-23.36	46	33.45	17.48	2.84	31.13	-	-	Peak
928.6	26.75	-19.25	46	29.59	23.61	4.22	30.67	-	-	Peak
5785	103.38	-	-	94.37	35.11	8.42	34.52	100	245	Peak
5785	91.69	-	-	82.7	35.09	8.42	34.52	100	245	Average
8452	54.4	-19.6	74	43.36	36	10.14	35.1	100	62	Peak
8452	40.71	-13.29	54	29.67	36	10.14	35.1	100	62	Average
11570	48.42	-25.58	74	82.85	-11.49	11.69	34.63	100	205	Peak
11570	35.5	-18.5	54	69.93	-11.49	11.69	34.63	100	205	Average
17355	54.19	-29.19	83.38	84.99	-11.57	15	34.23	100	0	Peak





<b>Test Mode :</b>	Mode 16	<b>Temperature :</b>	22~23°C
<b>Test Channel :</b>	165	<b>Relative Humidity :</b>	42~43%
<b>Test Engineer :</b>	Kay Wu	<b>Polarization :</b>	Horizontal
<b>Remark :</b>	1. 5825 MHz is Fundamental Signals which can be ignored. 2. 17475 MHz is not within a restricted band.		

Frequency ( MHz )	Level ( dBuV/m )	Over Limit ( dB )	Limit Line ( dBuV/m )	Read Level ( dBuV )	Antenna Factor ( dB )	Cable Loss ( dB )	Preamp Factor ( dB )	Ant Pos ( cm )	Table Pos ( deg )	Remark
30	23.15	-16.85	40	34.7	19.51	0.64	31.7	100	65	Peak
144.21	21.49	-22.01	43.5	40.25	11.47	1.43	31.66	-	-	Peak
172.02	22.19	-21.31	43.5	42.73	9.53	1.56	31.63	-	-	Peak
318.2	21.49	-24.51	46	36.69	13.95	2.21	31.36	-	-	Peak
399.4	23.23	-22.77	46	35.78	16.11	2.54	31.2	-	-	Peak
928.6	27.37	-18.63	46	30.21	23.61	4.22	30.67	-	-	Peak
5825	106.3	-	-	97.24	35.16	8.43	34.53	100	303	Peak
5825	94.57	-	-	85.51	35.16	8.43	34.53	100	303	Average
8390	55.39	-18.61	74	44.38	36	10.11	35.1	100	67	Peak
8390	40.68	-13.32	54	29.67	36	10.11	35.1	100	67	Average
11650	53.16	-20.84	74	87.22	-11.14	11.74	34.66	100	304	Peak
11650	39.12	-14.88	54	73.18	-11.14	11.74	34.66	100	304	Average
17475	61.91	-24.39	86.30	93.02	-12.07	15.17	34.21	100	0	Peak



<b>Test Mode :</b>	Mode 16	<b>Temperature :</b>	22~23°C
<b>Test Channel :</b>	165	<b>Relative Humidity :</b>	42~43%
<b>Test Engineer :</b>	Kay Wu	<b>Polarization :</b>	Vertical
<b>Remark :</b>	1. 5825 MHz is Fundamental Signals which can be ignored. 2. 17475 MHz is not within a restricted band.		

Frequency ( MHz )	Level ( dBuV/m )	Over Limit ( dB )	Limit Line ( dBuV/m )	Read Level ( dBuV )	Antenna Factor ( dB )	Cable Loss ( dB )	Preamp Factor ( dB )	Ant Pos ( cm )	Table Pos ( deg )	Remark
51.06	30.61	-9.39	40	53.7	7.77	0.84	31.7	-	-	Peak
71.85	31.44	-8.56	40	55.4	6.77	0.97	31.7	100	57	Peak
164.73	27.71	-15.79	43.5	47.78	10.03	1.53	31.63	-	-	Peak
466.6	22.45	-23.55	46	33.26	17.48	2.84	31.13	-	-	Peak
752.2	23.55	-22.45	46	29.08	21.56	3.71	30.8	-	-	Peak
903.4	26.74	-19.26	46	30.05	23.22	4.17	30.7	-	-	Peak
5825	102.56	-	-	93.5	35.16	8.43	34.53	100	249	Peak
5825	90.38	-	-	81.32	35.16	8.43	34.53	100	249	Average
8310	54.12	-19.88	74	43.17	36	10.05	35.1	100	86	Peak
8310	40.26	-13.74	54	29.31	36	10.05	35.1	100	86	Average
11650	49.26	-24.74	74	83.32	-11.14	11.74	34.66	100	203	Peak
11650	36.01	-17.99	54	70.07	-11.14	11.74	34.66	100	203	Average
17475	55.03	-29.53	82.56	86.19	-12.12	15.17	34.21	100	0	Peak



<b>Test Mode :</b>	Mode 17	<b>Temperature :</b>	22~23°C
<b>Test Channel :</b>	165	<b>Relative Humidity :</b>	42~43%
<b>Test Engineer :</b>	Kay Wu	<b>Polarization :</b>	Horizontal
<b>Remark :</b>	5825 MHz is Fundamental Signals which can be ignored.		

Frequency ( MHz )	Level ( dBuV/m )	Over Limit ( dB )	Limit Line ( dBuV/m )	Read Level ( dBuV )	Antenna Factor ( dB )	Cable Loss ( dB )	Preamp Factor ( dB )	Ant Pos ( cm )	Table Pos ( deg )	Remark
30	22.07	-17.93	40	33.62	19.51	0.64	31.7	100	335	Peak
113.7	20.29	-23.21	43.5	39.14	11.6	1.24	31.69	-	-	Peak
159.33	19.29	-24.21	43.5	38.96	10.46	1.51	31.64	-	-	Peak
368.6	21.87	-24.13	46	35.41	15.29	2.43	31.26	-	-	Peak
453.3	23.22	-22.78	46	34.36	17.2	2.81	31.15	-	-	Peak
671	23.39	-22.61	46	30.23	20.62	3.47	30.93	-	-	Peak
5825	106.15	-	-	97.09	35.16	8.43	34.53	100	331	Peak
5825	94.1	-	-	85.04	35.16	8.43	34.53	100	331	Average
8372	53.52	-20.48	74	42.52	36	10.1	35.1	100	214	Peak
8372	40.11	-13.89	54	29.11	36	10.1	35.1	100	214	Average
11650	49.12	-24.88	74	83.18	-11.14	11.74	34.66	100	0	Peak



<b>Test Mode :</b>	Mode 17	<b>Temperature :</b>	22~23°C
<b>Test Channel :</b>	165	<b>Relative Humidity :</b>	42~43%
<b>Test Engineer :</b>	Kay Wu	<b>Polarization :</b>	Vertical
<b>Remark :</b>	5825 MHz is Fundamental Signals which can be ignored.		

Frequency ( MHz )	Level ( dBuV/m )	Over Limit ( dB )	Limit Line ( dBuV/m )	Read Level ( dBuV )	Antenna Factor ( dB )	Cable Loss ( dB )	Preamp Factor ( dB )	Ant Pos ( cm )	Table Pos ( deg )	Remark
30.54	26.49	-13.51	40	38.59	18.95	0.65	31.7	-	-	Peak
72.66	27.67	-12.33	40	51.54	6.86	0.97	31.7	100	251	Peak
91.02	24.31	-19.19	43.5	45.86	9.03	1.12	31.7	-	-	Peak
379.8	20.54	-25.46	46	33.7	15.6	2.48	31.24	-	-	Peak
503	24.05	-21.95	46	33.96	18.24	2.95	31.1	-	-	Peak
680.1	24.85	-21.15	46	31.6	20.68	3.49	30.92	-	-	Peak
5825	104.05	-	-	94.99	35.16	8.43	34.53	100	241	Peak
5825	92.6	-	-	83.54	35.16	8.43	34.53	100	241	Average
8462	53.26	-20.74	74	42.2	36	10.16	35.1	100	29	Peak
8462	39.4	-14.6	54	28.34	36	10.16	35.1	100	29	Average
11650	44.54	-29.46	74	78.6	-11.14	11.74	34.66	100	0	Peak



## **3.8 Antenna Requirements**

### **3.8.1 Standard Applicable**

If directional gain of transmitting antennas is greater than 6dBi, the power shall be reduced by the same level in dB comparing to gain minus 6dBi. For the fixed point-to-point operation, the power shall be reduced by one dB for every 3 dB that the directional gain of the antenna exceeds 6 dBi. The use of a permanently attached antenna or of an antenna that uses a unique coupling to the intentional radiator shall be considered sufficient to comply with the FCC rule.

### **3.8.2 Antenna Connected Construction**

The antennas type used in this product is PIFA Antenna without connector and it is considered to meet antenna requirement.

### **3.8.3 Antenna Gain**

The antenna peak gain of EUT is less than 6 dBi. Therefore, it is not necessary to reduce maximum peak output power limit.

## 4 List of Measuring Equipment

Instrument	Manufacturer	Model No.	Serial No.	Characteristics	Calibration Date	Due Date	Remark
Spectrum Analyzer	R&S	FSP40	100055	9kHz~40GHz	Jun. 23, 2009	Jun. 22, 2010	Conducted (TH02-HY)
Power Meter	Anritsu	ML2495A	0932001	N/A	Sep. 17, 2009	Sep. 16, 2010	Conducted (TH02-HY)
Power Sensor	Anritsu	MA2411B	0846202	N/A	Sep. 10, 2009	Sep. 09, 2010	Conducted (TH02-HY)
EMI Test Receive	R&S	ESCS 30	100356	9KHz – 2.75GHz	Aug. 05, 2009	Aug. 04, 2010	Conduction (CO05-HY)
Two-LISN	R&S	ENV216	11-100081	9kHz~30MHz	Nov. 30, 2009	Nov. 29, 2010	Conduction (CO05-HY)
Two-LISN	R&S	ENV216	11-100080	9kHz~30MHz	Nov. 23, 2009	Nov. 22, 2010	Conduction (CO05-HY)
AC Power Source	APC	APC-1000W	N/A	N/A	N/A	N/A	Conduction (CO05-HY)
System Simulator	R&S	CMU200	105934	N/A	Nov. 11, 2008	Nov. 10, 2010	Conduction (CO05-HY)
GPS Station	T&E	GS-50	N/A	N/A	N/A	N/A	Conduction (CO05-HY)
Bilog Antenna	SCHAFFNER	CBL6111C	2726	30MHz ~ 1GHz	Oct. 31, 2009	Oct. 30, 2010	Radiation (03CH07-HY)
Spectrum Analyzer	R&S	FSP	101067	9KHz ~ 30GHz	Dec. 04, 2009	Dec. 03, 2010	Radiation (03CH07-HY)
Double Ridge Horn Antenna	ESCO	3117	00075962	1GHz ~ 18GHz	Aug. 20, 2009	Aug. 19, 2010	Radiation (03CH07-HY)
SHF-EHF Horn Antenna	SCHWARZBECK	BBHA 9170	BBHA9170251	15GHz- 40GHz	Oct. 14, 2009	Oct. 13, 2010	Radiation (03CH07-HY)
Pre Amplifier	Agilent	8449B	3008A02362	1GHz~ 26.5GHz	Dec.09,2009	Dec. 08, 2010	Radiation (03CH07-HY)
Pre Amplifier	COM-POWER	PA-103A	161241	10-1000MHz.32 dB.GAIN	Mar. 27, 2009	Mar. 26, 2010	Radiation (03CH07-HY)
Loop Antenna	R&S	HFH2-Z2	860004/001	9 KHz~30 MHz	May 22, 2008	May 21, 2010	Radiation (03CH07-HY)

## 5 Uncertainty of Evaluation

### Uncertainty of Conducted Emission Measurement (150kHz ~ 30MHz)

Contribution	Uncertainty of $X_i$		$u(X_i)$
	dB	Probability Distribution	
Receiver Reading	0.10	Normal (k=2)	0.05
Cable Loss	0.10	Normal (k=2)	0.05
AMN Insertion Loss	2.50	Rectangular	0.63
Receiver Specification	1.50	Rectangular	0.43
Site Imperfection	1.39	Rectangular	0.80
Mismatch	+0.34 / -0.35	U-Shape	0.24
<b>Combined Standard Uncertainty <math>U_c(y)</math></b>	<b>1.13</b>		
<b>Measuring Uncertainty for a Level of Confidence of 95% (<math>U = 2U_c(y)</math>)</b>	<b>2.26</b>		

### Uncertainty of Radiated Emission Measurement (30MHz ~ 1000MHz)

Contribution	Uncertainty of $X_i$		$u(X_i)$
	dB	Probability Distribution	
Receiver Reading	0.41	Normal (k=2)	0.21
Antenna Factor Calibration	0.83	Normal (k=2)	0.42
Cable Loss Calibration	0.25	Normal (k=2)	0.13
Pre-Amplifier Gain Calibration	0.27	Normal (k=2)	0.14
RCV/SPA Specification	2.50	Rectangular	0.72
Antenna Factor Interpolation for Frequency	1.00	Rectangular	0.29
Site Imperfection	1.43	Rectangular	0.83
Mismatch	+0.39 / -0.41	U-Shape	0.28
<b>Combined Standard Uncertainty <math>U_c(y)</math></b>	<b>1.27</b>		
<b>Measuring Uncertainty for a Level of Confidence of 95% (<math>U = 2U_c(y)</math>)</b>	<b>2.54</b>		



**Uncertainty of Radiated Emission Measurement (1GHz ~ 40GHz)**

Contribution	Uncertainty of $X_i$		$u(X_i)$	$C_i$	$C_i * u(X_i)$
	dB	Probability Distribution			
Receiver Reading	±0.10	Normal (k=2)	0.10	1	0.10
Antenna Factor Calibration	±1.70	Normal (k=2)	0.85	1	0.85
Cable Loss Calibration	±0.50	Normal (k=2)	0.25	1	0.25
Receiver Correction	±2.00	Rectangular	1.15	1	1.15
Antenna Factor Directional	±1.50	Rectangular	0.87	1	0.87
Site Imperfection	±2.80	Triangular	1.14	1	1.14
Mismatch Receiver VSWR $\Gamma_1 = 0.197$ Antenna VSWR $\Gamma_2 = 0.194$ Uncertainty = $20\text{Log}(1-\Gamma_1*\Gamma_2)$	+0.34 / -0.35	U-Shape	0.244	1	0.244
<b>Combined Standard Uncertainty <math>U_c(y)</math></b>	<b>2.36</b>				
<b>Measuring Uncertainty for a Level of Confidence of 95% (<math>U = 2U_c(y)</math>)</b>	<b>4.72</b>				





## **Appendix A. Photographs of EUT**

Please refer to Sporton report number EP010801 as below.