



SUPPLEMENTARY FCC TEST REPORT

REPORT NO.: RF120903C21S-2
MODEL NO.: MC40N0
FCC ID: UZ7MC40N0
RECEIVED: Mar. 23, 2015
TESTED: Apr. 02, 2015 ~ Apr. 16, 2015
ISSUED: Jun. 05, 2015

APPLICANT: Zebra Technologies Corporation

ADDRESS: 1 Zebra Plaza, Holtsville, NY 11742

ISSUED BY: Bureau Veritas Consumer Products Services (H.K.)
Ltd., Taoyuan Branch

LAB ADDRESS: No. 47-2, 14th Ling, Chia Pau Vil., Lin Kou Dist.,
New Taipei City, Taiwan (R.O.C)

TEST LOCATION: No. 19, Hwa Ya 2nd Rd, Wen Hwa Vil., Kwei Shan
Dist., Taoyuan City 33383, Taiwan (R.O.C.)

This report should not be used by the client to claim product certification, approval, or endorsement by TAF or any government agencies.



This report is for your exclusive use. Any copying or replication of this report to or for any other person or entity, or use of our name or trademark, is permitted only with our prior written permission. This report sets forth our findings solely with respect to the test samples identified herein. The results set forth in this report are not indicative or representative of the quality or characteristics of the lot from which a test sample was taken or any similar or identical product unless specifically and expressly noted. Our report includes all of the tests requested by you and the results thereof based upon the information that you provided to us. You have 60 days from date of issuance of this report to notify us of any material error or omission caused by our negligence, provided, however, that such notice shall be in writing and shall specifically address the issue you wish to raise. A failure to raise such issue within the prescribed time shall constitute your unqualified acceptance of the completeness of this report, the tests conducted and the correctness of the report contents. Unless specific mention, the uncertainty of measurement has been explicitly taken into account to declare the compliance or non-compliance to the specification.



TABLE OF CONTENTS

REPORT ISSUE HISTORY RECORD4

RELEASE CONTROL RECORD5

1. CERTIFICATION.....6

2. SUMMARY OF TEST RESULTS7

 2.1 MEASUREMENT UNCERTAINTY.....7

3. GENERAL INFORMATION8

 3.1 GENERAL DESCRIPTION OF EUT8

 3.2 DESCRIPTION OF TEST MODES9

 3.2.1 TEST MODE APPLICABILITY AND TESTED CHANNEL DETAIL 10

 3.3 DESCRIPTION OF SUPPORT UNITS 12

 3.3.1 CONFIGURATION OF SYSTEM UNDER TEST 12

 3.4 GENERAL DESCRIPTION OF APPLIED STANDARDS 13

4. TEST TYPES AND RESULTS (FOR BLUETOOTH EDR) 14

 4.1 RADIATED EMISSION AND BANDEDGE MEASUREMENT 14

 4.1.1 LIMITS OF RADIATED EMISSION AND BANDEDGE MEASUREMENT 14

 4.1.2 TEST INSTRUMENTS 15

 4.1.3 TEST PROCEDURES 16

 4.1.4 DEVIATION FROM TEST STANDARD 16

 4.1.5 TEST SETUP 17

 4.1.6 EUT OPERATING CONDITIONS 17

 4.1.7 TEST RESULTS..... 18

 4.2 CONDUCTED EMISSION MEASUREMENT 30

 4.2.1 LIMITS OF CONDUCTED EMISSION MEASUREMENT 30

 4.2.2 TEST INSTRUMENTS 30

 4.2.3 TEST PROCEDURES 31

 4.2.4 DEVIATION FROM TEST STANDARD 31

 4.2.5 TEST SETUP 32

 4.2.6 EUT OPERATING CONDITIONS 32

 4.2.7 TEST RESULTS..... 33

 4.3 NUMBER OF HOPPING FREQUENCY USED 37

 4.3.1 LIMIT OF HOPPING FREQUENCY USED 37

 4.3.2 TEST SETUP 37

 4.3.3 TEST INSTRUMENTS 37

 4.3.4 TEST PROCEDURE 37

 4.3.5 DEVIATION FROM TEST STANDARD 37

 4.3.6 TEST RESULTS..... 37

 4.4 DWELL TIME ON EACH CHANNEL 39

 4.4.1 LIMITS OF DWELL TIME USED 39

 4.4.2 TEST SETUP 39

 4.4.3 TEST INSTRUMENTS 39

 4.4.4 TEST PROCEDURES 39

 4.4.5 DEVIATION FROM TEST STANDARD 39

 4.4.6 TEST RESULTS..... 40

 4.5 CHANNEL BANDWIDTH 43

 4.5.1 LIMITS OF CHANNEL BANDWIDTH 43

 4.5.2 TEST SETUP 43

 4.5.3 TEST INSTRUMENTS 43

 4.5.4 TEST PROCEDURE 43

 4.5.5 DEVIATION FROM TEST STANDARD 43

 4.5.6 EUT OPERATING CONDITION 43

 4.5.7 TEST RESULTS..... 44



4.6	HOPPING CHANNEL SEPARATION	45
4.6.1	LIMITS OF HOPPING CHANNEL SEPARATION	45
4.6.2	TEST SETUP	45
4.6.3	TEST INSTRUMENTS	45
4.6.4	TEST PROCEDURE	45
4.6.5	DEVIATION FROM TEST STANDARD	45
4.6.6	TEST RESULTS.....	46
4.7	MAXIMUM OUTPUT POWER	47
4.7.1	LIMITS OF MAXIMUM OUTPUT POWER MEASUREMENT	47
4.7.2	TEST SETUP	47
4.7.3	TEST INSTRUMENTS	47
4.7.4	TEST PROCEDURE	47
4.7.5	DEVIATION FROM TEST STANDARD	47
4.7.6	EUT OPERATING CONDITION.....	47
4.7.7	TEST RESULTS.....	48
4.8	CONDUCTED OUT OF BAND EMISSION MEASUREMENT	49
4.8.1	LIMITS OF CONDUCTED OUT OF BAND EMISSION MEASUREMENT	49
4.8.2	TEST INSTRUMENTS.....	49
4.8.3	TEST PROCEDURE	49
4.8.4	DEVIATION FROM TEST STANDARD	49
4.8.5	EUT OPERATING CONDITION.....	49
4.8.6	TEST RESULTS.....	49
5.	PHOTOGRAPHS OF THE TEST CONFIGURATION.....	53
6.	INFORMATION ON THE TESTING LABORATORIES	54
7.	APPENDIX A – MODIFICATIONS RECORDERS FOR ENGINEERING CHANGES TO THE EUT BY THE LAB	55



A D T

REPORT ISSUE HISTORY RECORD

ISSUE NO.	REASON FOR CHANGE	DATE ISSUED
1	Original release	Sep. 17, 2012
2	1. New LCM, TP, Scanner engine, larger speaker and MIC 2. New antenna design (WLAN1, WLAN2) and new antenna location (WLAN2, BT) 3. New Schematic, Block Diagram 4. Update SW and HW	Jun. 05, 2015



A D T

RELEASE CONTROL RECORD

ISSUE NO.	REASON FOR CHANGE	DATE ISSUED
RF120903C21S-2	Original release	Jun. 05, 2015



1. CERTIFICATION

PRODUCT: Mobile Computer
MODEL NO.: MC40N0
BRAND: Symbol
APPLICANT: Zebra Technologies Corporation
TESTED: Apr. 02, 2015 ~ Apr. 16, 2015
TEST SAMPLE: Engineering Sample
STANDARDS: **FCC Part 15, Subpart C (Section 15.247)**
ANSI C63.10-2013

The above equipment (model: MC40N0) has been tested by **Bureau Veritas Consumer Products Services (H.K.) Ltd., Taoyuan Branch**, and found compliance with the requirement of the above standards. The test record, data evaluation & Equipment Under Test (EUT) configurations represented herein are true and accurate accounts of the measurements of the sample's EMC characteristics under the conditions specified in this report.

PREPARED BY : Rona Chen , **DATE :** Jun. 05, 2015
Rona Chen / Specialist

APPROVED BY : Sam chen , **DATE :** Jun. 05, 2015
Sam Chen / Senior Project Engineer

2. SUMMARY OF TEST RESULTS

The EUT has been tested according to the following specifications:

APPLIED STANDARD: FCC Part 15, Subpart C (Bluetooth EDR)			
STANDARD SECTION	TEST TYPE AND LIMIT	RESULT	REMARK
15.207	AC Power Conducted Emission	PASS	Meet the requirement of limit. Minimum passing margin is -8.21dB at 0.37287MHz.
15.247(a)(1) (iii)	Number of Hopping Frequency Used	PASS	Meet the requirement of limit.
15.247(a)(1) (iii)	Dwell Time on Each Channel	PASS	Meet the requirement of limit.
15.247(a)(1)	1. Hopping Channel Separation 2. Spectrum Bandwidth of a Frequency Hopping Sequence Spread Spectrum System	PASS	Meet the requirement of limit.
15.247(b)	Maximum Peak Output Power	PASS	Meet the requirement of limit.
15.247(d)	Transmitter Radiated Emissions	PASS	Meet the requirement of limit. Minimum passing margin is -9.02dB at 79.68MHz.
15.247(d)	Band Edge Measurement	PASS	Meet the requirement of limit.
15.203	Antenna Requirement	PASS	No antenna connector is used.

NOTE: If The Frequency Hopping System operating in 2400-2483.5MHz band and the output power less than 125mW. The hopping channel carrier frequencies separated by a minimum of 25kHz or two-thirds of the 20dB bandwidth of hopping channel whichever is greater.

2.1 MEASUREMENT UNCERTAINTY

Where relevant, the following measurement uncertainty levels have been estimated for tests performed on the EUT as specified in CISPR 16-4-2:

MEASUREMENT	FREQUENCY	UNCERTAINTY
Conducted emissions	9kHz~30MHz	2.44 dB
Radiated emissions	30MHz ~ 200MHz	2.93 dB
	200MHz ~1000MHz	2.95 dB
	1GHz ~ 18GHz	2.26 dB
	18GHz ~ 40GHz	1.94 dB

This uncertainty represents an expanded uncertainty expressed at approximately the 95% confidence level using a coverage factor of $k = 2$.



3. GENERAL INFORMATION

3.1 GENERAL DESCRIPTION OF EUT

EUT	Mobile Computer	
MODEL NO.	MC40N0	
POWER SUPPLY	5Vdc (adapter or host equipment) 3.7Vdc (Li-ion battery)	
MODULATION TYPE	Bluetooth EDR	GFSK, $\pi/4$ -DQPSK, 8DPSK
TRANSFER RATE	Bluetooth EDR	1/2/3Mbps
OPERATING FREQUENCY	2402 ~ 2480MHz	
NUMBER OF CHANNEL	Bluetooth EDR	79
CHANNEL SPACING	Bluetooth EDR	1MHz
OUTPUT POWER	Bluetooth EDR	2.138mW
ANTENNA TYPE	PIFA antenna with 3.1dBi gain	
ANTENNA CONNECTOR	NA	
DATA CABLE	Refer to Note as below	
I/O PORTS	Refer to user's manual	
ACCESSORY DEVICES	Refer to Note as below	
HW VERSION	EV2	
SW VERSION	Android version: 4.4.4 Build number: 99-4AJ22-K-0008-0004-V0-M1-031315	

NOTE:

1. This report is issued as a supplementary report of BV ADT report no.: RF120903C21-2. For more detail of difference compared with original report, please refer to issued no. 2 of "report issue history record" on page 5. Therefore, all items had been performed and presented in the test report.
2. The device is available with or without MSR.
3. The following accessories are optional.

ITEM	BRAND	MODEL	SPECIFICATION
Adapter	Motorola / Symbol	IU08-2050120-WP	I/P: 100-240Vac, 50/60Hz, 0.2A O/P: 5Vdc, 1.2A
Earphone 1	Symbol / Zebra	NA	1.3m non-shielded cable w/o core
Earphone 2	Symbol / Zebra	21-UNIV-HDSET1-01R	1.2m non-shielded cable w/o core
Micro USB Cable	Symbol / Zebra	25-MCXUSB-01R	1.5m shielded cable w/o core
Holster	Symbol / Zebra	SG-MC40HLSTR-03R	--
Handstrap	Symbol / Zebra	SG-MC40Strap-10R	--

4. The EUT uses following battery.

Brand	Symbol / Zebra
Rating	3.7Vdc

5. The above EUT information is declared by the manufacturer and for more detailed features description, please refer to the manufacturer's specifications or User's Manual.



A D T

3.2 DESCRIPTION OF TEST MODES

Bluetooth EDR:

79 channels are provided to this EUT:

CHANNEL	FREQ. (MHz)	CHANNEL	FREQ. (MHz)	CHANNEL	FREQ. (MHz)	CHANNEL	FREQ. (MHz)
0	2402	20	2422	40	2442	60	2462
1	2403	21	2423	41	2443	61	2463
2	2404	22	2424	42	2444	62	2464
3	2405	23	2425	43	2445	63	2465
4	2406	24	2426	44	2446	64	2466
5	2407	25	2427	45	2447	65	2467
6	2408	26	2428	46	2448	66	2468
7	2409	27	2429	47	2449	67	2469
8	2410	28	2430	48	2450	68	2470
9	2411	29	2431	49	2451	69	2471
10	2412	30	2432	50	2452	70	2472
11	2413	31	2433	51	2453	71	2473
12	2414	32	2434	52	2454	72	2474
13	2415	33	2435	53	2455	73	2475
14	2416	34	2436	54	2456	74	2476
15	2417	35	2437	55	2457	75	2477
16	2418	36	2438	56	2458	76	2478
17	2419	37	2439	57	2459	77	2479
18	2420	38	2440	58	2460	78	2480
19	2421	39	2441	59	2461		



3.2.1 TEST MODE APPLICABILITY AND TESTED CHANNEL DETAIL

BLUETOOTH EDR

EUT CONFIGURE MODE	APPLICABLE TO				DESCRIPTION
	RE≥1G	RE<1G	PLC	APCM	
A	√	√	√	√	With MSR SKU
B	√	√	√	-	Without MSR SKU

Where **RE≥1G**: Radiated Emission above 1GHz **RE<1G**: Radiated Emission below 1GHz
PLC: Power Line Conducted Emission **APCM**: Antenna Port Conducted Measurement

NOTE: 1. For Radiated emission test, pre-tested GFSK, π/4-DQPSK, 8DPSK modulation type and found 8DPSK was the worse, therefore chosen for the final test and presented in the test report.
2. The EUT had been pre-tested on the positioned of each 3 axis. The worst case was found when positioned on **Y-plane**.

RADIATED EMISSION TEST (ABOVE 1GHz):

- Pre-Scan has been conducted to determine the worst-case mode from all possible combinations between available modulations, data rates and antenna ports (if EUT with antenna diversity architecture).
- Following channel(s) was (were) selected for the final test as listed below.

EUT CONFIGURE MODE	AVAILABLE CHANNEL	TESTED CHANNEL	MODULATION TYPE	PACKET TYPE
A, B	0 to 78	0, 39, 78	8DPSK	DH5

RADIATED EMISSION TEST (BELOW 1GHz):

- Pre-Scan has been conducted to determine the worst-case mode from all possible combinations between available modulations, data rates and antenna ports (if EUT with antenna diversity architecture).
- Following channel(s) was (were) selected for the final test as listed below.

EUT CONFIGURE MODE	AVAILABLE CHANNEL	TESTED CHANNEL	MODULATION TYPE	PACKET TYPE
A, B	0 to 78	0, 39, 78	8DPSK	DH5

POWER LINE CONDUCTED EMISSION TEST:

- Pre-Scan has been conducted to determine the worst-case mode from all possible combinations between available modulations, data rates and antenna ports (if EUT with antenna diversity architecture).
- Following channel(s) was (were) selected for the final test as listed below.

EUT CONFIGURE MODE	AVAILABLE CHANNEL	TESTED CHANNEL	MODULATION TYPE	PACKET TYPE
A, B	0 to 78	0	8DPSK	DH5



A D T

ANTENNA PORT CONDUCTED MEASUREMENT:

- This item includes all test value of each mode, but only includes spectrum plot of worst value of each mode.
- Pre-Scan has been conducted to determine the worst-case mode from all possible combinations between available modulations, data rates and antenna ports (if EUT with antenna diversity architecture).
- Following channel(s) was (were) selected for the final test as listed below.

EUT CONFIGURE MODE	AVAILABLE CHANNEL	TESTED CHANNEL	MODULATION TYPE	PACKET TYPE
A	0 to 78	0, 39, 78	GFSK	DH5
A	0 to 78	0, 39, 78	$\pi/4$ -DQPSK	DH5
A	0 to 78	0, 39, 78	8DPSK	DH5

TEST CONDITION:

APPLICABLE TO	ENVIRONMENTAL CONDITIONS	INPUT POWER	TESTED BY
RE \geq 1G	25deg. C, 65%RH	120Vac, 60Hz	Toby Tian
RE $<$ 1G	25deg. C, 65%RH	120Vac, 60Hz	Toby Tian
PLC	25deg. C, 65%RH	120Vac, 60Hz	Toby Tian
APCM	25deg. C, 65%RH	120Vac, 60Hz	Howard Kao

3.3 DESCRIPTION OF SUPPORT UNITS

The EUT has been tested as an independent unit together with other necessary accessories or support units.

3.3.1 CONFIGURATION OF SYSTEM UNDER TEST

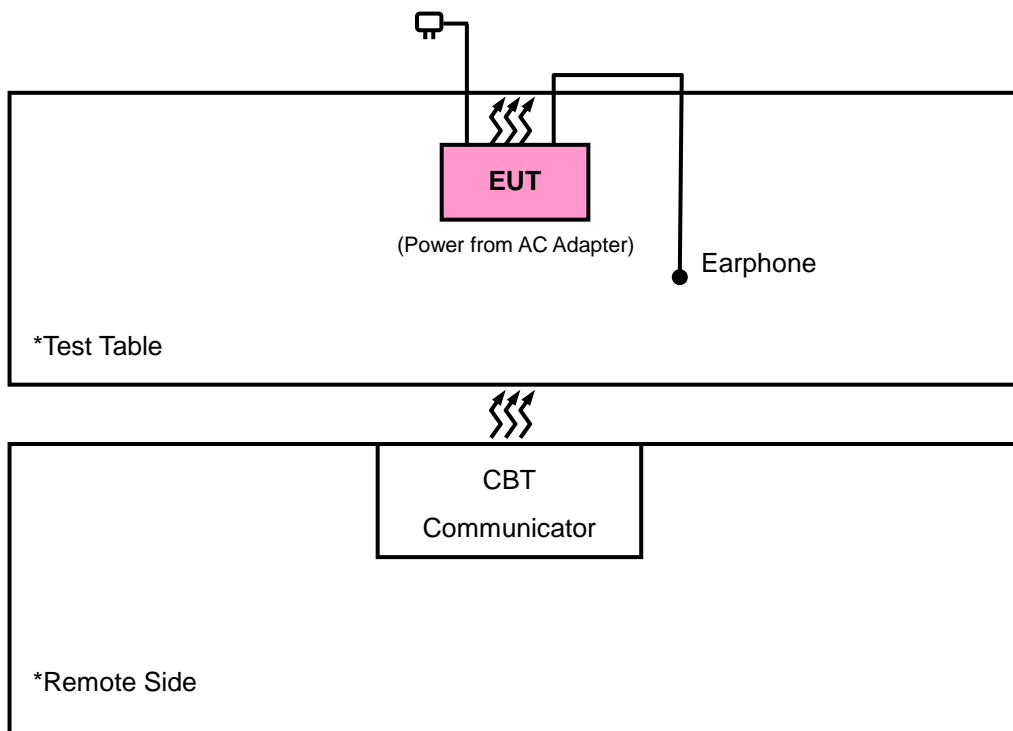



3.4 GENERAL DESCRIPTION OF APPLIED STANDARDS

The EUT is a RF Product. According to the specifications of the manufacturer, it must comply with the requirements of the following standards:

FCC Part 15, Subpart C (15.247)

ANSI C63.10-2013

FCC Public Notice DA 00-705

All test items have been performed and recorded as per the above standards.

NOTE: The EUT has been verified to comply with the requirements of FCC Part 15, Subpart B, Class B (DoC). The test report has been issued separately.

4. TEST TYPES AND RESULTS (FOR BLUETOOTH EDR)

4.1 RADIATED EMISSION AND BANDEDGE MEASUREMENT

4.1.1 LIMITS OF RADIATED EMISSION AND BANDEDGE MEASUREMENT

Radiated emissions which fall in the restricted bands must comply with the radiated emission limits specified as below table. Other emissions shall be at least 20dB below the highest level of the desired power:

FREQUENCIES (MHz)	FIELD STRENGTH (microvolts/meter)	MEASUREMENT DISTANCE (meters)
0.009 ~ 0.490	2400/F(kHz)	300
0.490 ~ 1.705	24000/F(kHz)	30
1.705 ~ 30.0	30	30
30 ~ 88	100	3
88 ~ 216	150	3
216 ~ 960	200	3
Above 960	500	3

NOTE:

1. The lower limit shall apply at the transition frequencies.
2. Emission level (dBuV/m) = 20 log Emission level (uV/m).
3. For frequencies above 1000MHz, the field strength limits are based on average detector, however, the peak field strength of any emission shall not exceed the maximum permitted average limits, specified above by more than 20dB under any condition of modulation.



A D T

4.1.2 TEST INSTRUMENTS

DESCRIPTION & MANUFACTURER	MODEL NO.	SERIAL NO.	DATE OF CALIBRATION	DUE DATE OF CALIBRATION
Test Receiver Agilent	N9038A	MY51210203	Jan.21, 2015	Jan.21, 2016
Spectrum Analyzer Agilent	N9010A	MY52220314	Sep.03, 2014	Sep.02, 2015
Spectrum Analyzer ROHDE & SCHWARZ	FSU43	101261	Dec. 10, 2014	Dec. 09, 2015
BILOG Antenna SCHWARZBECK	VULB9168	9168-472	Feb. 04, 2015	Feb. 04, 2016
HORN Antenna SCHWARZBECK	BBHA 9120 D	9120D-969	Feb. 09, 2015	Feb. 09, 2016
HORN Antenna SCHWARZBECK	BBHA 9170	9170-480	Feb. 04, 2015	Feb. 04, 2016
Loop Antenna	EM-6879	269	Aug.13, 2014	Aug.12, 2015
Preamplifier Agilent	8449B	3008A01911	Aug. 09, 2014	Aug. 08, 2015
Preamplifier EMCI	EMC 012645	980115	Dec. 12, 2014	Dec. 11, 2015
Preamplifier EMCI	EMC 184045	980116	Jan. 09, 2015	Jan. 08, 2016
Preamplifier EMCI	EMC 330H	980112	Dec. 27, 2014	Dec. 26, 2015
RF signal cable HUBER+SUHNNER	SUCOFLEX 104	309219/4 2950114	Oct. 18, 2014	Oct. 17, 2015
RF signal cable HUBER+SUHNNER	SUCOFLEX 104	250130/4	Oct. 18, 2014	Oct. 17, 2015
RF signal cable Worken	RG-213	NA	Nov. 07, 2014	Nov. 06, 2015
Software BV ADT	E3 6.120103	NA	NA	NA
Antenna Tower MF	MFA-440H	NA	NA	NA
Turn Table MF	MFT-201SS	NA	NA	NA
Antenna Tower & Turn Table Controller MF	MF-7802	NA	NA	NA
Bluetooth Tester	CBT	100980	Feb. 10, 2015	Feb. 09, 2016
Power Meter	ML2495A	1232002	Sep. 17, 2014	Sep. 16, 2015
Power Sensor	MA2411B	1207325	Sep. 17, 2014	Sep. 16, 2015

NOTE: 1. The calibration interval of the above test instruments is 12 months and the calibrations are traceable to NML/ROC and NIST/USA.

2. The calibration interval of the loop antenna is 24 months and the calibrations are traceable to NML/ROC and NIST/USA.

3. The test was performed in HwaYa Chamber 10.

4. The horn antenna and HP preamplifier (model: 8449B) are used only for the measurement of emission frequency above 1GHz if tested.

5. The FCC Site Registration No. is 690701.

6. The IC Site Registration No. is IC 7450F-10.

4.1.3 TEST PROCEDURES

- a. The EUT was placed on the top of a rotating table 0.8 meters (for below 1GHz) / 1.5 meters (for above 1GHz) above the ground at 3 meter chamber room for test. The table was rotated 360 degrees to determine the position of the highest radiation.
- b. The EUT was set 3 meters away from the interference-receiving antenna, which was mounted on the top of a variable-height antenna tower.
- c. The antenna is a broadband antenna, and its height is varied from one meter to four meters above the ground to determine the maximum value of the field strength. Both horizontal and vertical polarizations of the antenna are set to make the measurement.
- d. For each suspected emission, the EUT was arranged to its worst case and then the antenna was tuned to heights from 1 meter to 4 meters and the rotatable table was turned from 0 degrees to 360 degrees to find the maximum reading.
- e. The test-receiver system was set to Peak Detect Function and Specified Bandwidth with Maximum Hold Mode.
- f. If the emission level of the EUT in peak mode was lower than the limit specified, then testing could be stopped and the peak values of the EUT would be reported. Otherwise the emissions would be re-tested one by one using peak, quasi-peak or average method as specified and then reported in a data sheet.

NOTE:

1. The resolution bandwidth and video bandwidth of test receiver/spectrum analyzer is 120kHz for Quasi-peak detection at frequency below 1GHz.
2. The resolution bandwidth of test receiver/spectrum analyzer is 1MHz and video bandwidth is 3MHz for Peak detection at frequency above 1GHz.
3. The resolution bandwidth of test receiver/spectrum analyzer is 1MHz and the video bandwidth is 10Hz for Average detection (AV) at frequency above 1GHz.

4.1.4 DEVIATION FROM TEST STANDARD

No deviation.

4.1.5 TEST SETUP

<Frequency Range 30MHz ~ 1GHz>

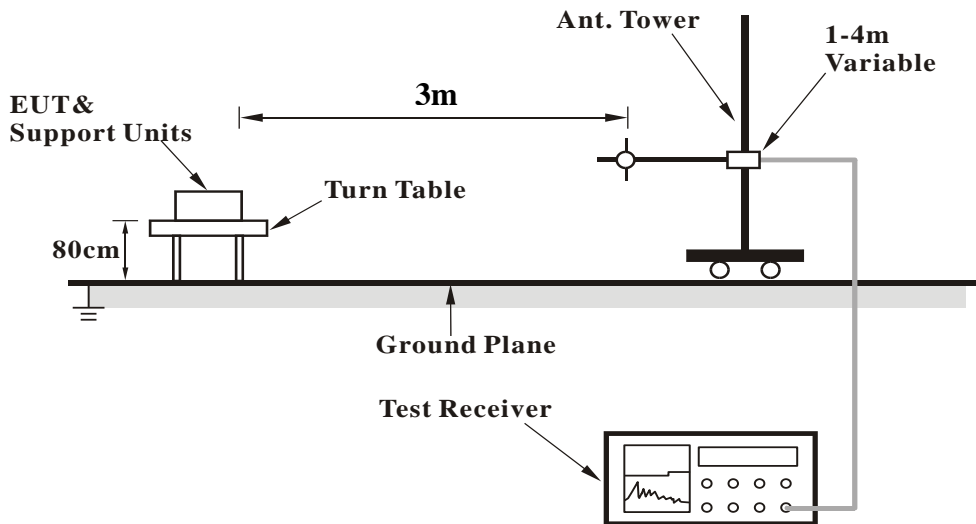

<Frequency Range above 1GHz>

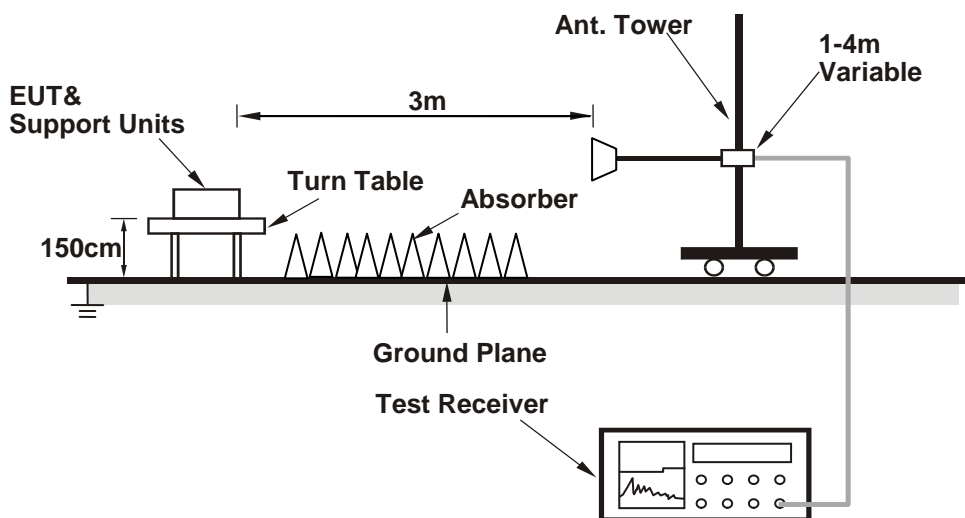

For the actual test configuration, please refer to the attached file (Test Setup Photo).

4.1.6 EUT OPERATING CONDITIONS

- a. Placed the EUT on a testing table.
- b. Use the software to control the EUT under transmission condition continuously at specific channel frequency.



A D T

4.1.7 TEST RESULTS

ABOVE 1GHz WORST-CASE DATA

8DPSK

Mode A

EUT TEST CONDITION		MEASUREMENT DETAIL	
CHANNEL	Channel 0	FREQUENCY RANGE	1GHz ~ 25GHz
INPUT POWER	120Vac, 60 Hz	DETECTOR FUNCTION	Peak (PK) Average (AV)
ENVIRONMENTAL CONDITIONS	25deg. C, 65%RH	TESTED BY	Toby Tian

ANTENNA POLARITY & TEST DISTANCE: HORIZONTAL AT 3 M										
FREQ. (MHz)	EMISSION LEVEL (dBuV/m)	READ LEVEL (dBuV)	LIMIT (dBuV/m)	MARGIN (dB)	ANTENNA FACTOR (dB/m)	CABLE LOSS (dB)	PREAMP FACTOR (dB)	ANTENNA HEIGHT (cm)	TABLE ANGLE (Degree)	REMARK
2356	33.6	40.78	54	-20.4	26.81	3.5	37.49	102	224	Average
2356	61.06	68.24	74	-12.94	26.81	3.5	37.49	102	224	Peak
2402	83.92	90.99			26.91	3.54	37.52	102	224	Average
2402	98.07	105.14			26.91	3.54	37.52	102	224	Peak
2486	33.51	40.08	54	-20.49	27.15	3.6	37.32	102	224	Average
2486	57.13	63.7	74	-16.87	27.15	3.6	37.32	102	224	Peak
4804	40.65	57.03	54	-13.35	30.97	5.75	53.1	140	129	Average
4804	49.06	65.44	74	-24.94	30.97	5.75	53.1	140	129	Peak
ANTENNA POLARITY & TEST DISTANCE: VERTICAL AT 3 M										
FREQ. (MHz)	EMISSION LEVEL (dBuV/m)	READ LEVEL (dBuV)	LIMIT (dBuV/m)	MARGIN (dB)	ANTENNA FACTOR (dB/m)	CABLE LOSS (dB)	PREAMP FACTOR (dB)	ANTENNA HEIGHT (cm)	TABLE ANGLE (Degree)	REMARK
2388	33.79	40.84	54	-20.21	26.91	3.54	37.5	123	183	Average
2388	62.63	69.68	74	-11.37	26.91	3.54	37.5	123	183	Peak
2402	83.44	90.51			26.91	3.54	37.52	123	183	Average
2402	97.48	104.55			26.91	3.54	37.52	123	183	Peak
2496	33.64	40.07	54	-20.36	27.2	3.62	37.25	123	183	Average
2496	57.79	64.22	74	-16.21	27.2	3.62	37.25	123	183	Peak
4804	37.34	53.72	54	-16.66	30.97	5.75	53.1	124	194	Average
4804	46.05	62.43	74	-27.95	30.97	5.75	53.1	124	194	Peak

REMARKS:

- Emission Level = Read Level + Antenna Factor + Cable Loss - Preamp Factor
Margin value = Emission level – Limit value
- 2402MHz: Fundamental frequency.



A D T

EUT TEST CONDITION		MEASUREMENT DETAIL	
CHANNEL	Channel 39	FREQUENCY RANGE	1GHz ~ 25GHz
INPUT POWER	120Vac, 60 Hz	DETECTOR FUNCTION	Peak (PK) Average (AV)
ENVIRONMENTAL CONDITIONS	25deg. C, 65%RH	TESTED BY	Toby Tian

ANTENNA POLARITY & TEST DISTANCE: HORIZONTAL AT 3 M

FREQ. (MHz)	EMISSION LEVEL (dBuV/m)	READ LEVEL (dBuV)	LIMIT (dBuV/m)	MARGIN (dB)	ANTENNA FACTOR (dB/m)	CABLE LOSS (dB)	PREAMP FACTOR (dB)	ANTENNA HEIGHT (cm)	TABLE ANGLE (Degree)	REMARK
2388	33.15	40.2	54	-20.85	26.91	3.54	37.5	102	224	Average
2388	60.35	67.4	74	-13.65	26.91	3.54	37.5	102	224	Peak
2441	86	92.75			27.06	3.58	37.39	102	224	Average
2441	100.26	107.01			27.06	3.58	37.39	102	224	Peak
2494	33.77	40.2	54	-20.23	27.2	3.62	37.25	102	224	Average
2494	58.17	64.6	74	-15.83	27.2	3.62	37.25	102	224	Peak
4882	38.82	55.01	54	-15.18	31.06	5.8	53.05	100	180	Average
4882	46.75	62.94	74	-27.25	31.06	5.8	53.05	100	180	Peak

ANTENNA POLARITY & TEST DISTANCE: VERTICAL AT 3 M

FREQ. (MHz)	EMISSION LEVEL (dBuV/m)	READ LEVEL (dBuV)	LIMIT (dBuV/m)	MARGIN (dB)	ANTENNA FACTOR (dB/m)	CABLE LOSS (dB)	PREAMP FACTOR (dB)	ANTENNA HEIGHT (cm)	TABLE ANGLE (Degree)	REMARK
2358	33	40.18	54	-21	26.81	3.5	37.49	136	341	Average
2358	57.79	64.97	74	-16.21	26.81	3.5	37.49	136	341	Peak
2441	83.17	89.92			27.06	3.58	37.39	136	341	Average
2441	96.83	103.58			27.06	3.58	37.39	136	341	Peak
2496	33.69	40.12	54	-20.31	27.2	3.62	37.25	136	341	Average
2496	57.37	63.8	74	-16.63	27.2	3.62	37.25	136	341	Peak
4882	37.11	53.3	54	-16.89	31.06	5.8	53.05	108	194	Average
4882	45.71	61.9	74	-28.29	31.06	5.8	53.05	108	194	Peak

REMARKS:

- Emission Level = Read Level + Antenna Factor + Cable Loss - Preamp Factor
Margin value = Emission level – Limit value
- 2441MHz: Fundamental frequency.



A D T

EUT TEST CONDITION		MEASUREMENT DETAIL	
CHANNEL	Channel 78	FREQUENCY RANGE	1GHz ~ 25GHz
INPUT POWER	120Vac, 60 Hz	DETECTOR FUNCTION	Peak (PK) Average (AV)
ENVIRONMENTAL CONDITIONS	25deg. C, 65%RH	TESTED BY	Toby Tian

ANTENNA POLARITY & TEST DISTANCE: HORIZONTAL AT 3 M

FREQ. (MHz)	EMISSION LEVEL (dBuV/m)	READ LEVEL (dBuV)	LIMIT (dBuV/m)	MARGIN (dB)	ANTENNA FACTOR (dB/m)	CABLE LOSS (dB)	PREAMP FACTOR (dB)	ANTENNA HEIGHT (cm)	TABLE ANGLE (Degree)	REMARK
2348	32.95	40.17	54	-21.05	26.77	3.5	37.49	100	227	Average
2348	57.45	64.67	74	-16.55	26.77	3.5	37.49	100	227	Peak
2480	86.02	92.59			27.15	3.6	37.32	100	227	Average
2480	100.53	107.1			27.15	3.6	37.32	100	227	Peak
2496	37.97	44.4	54	-16.03	27.2	3.62	37.25	100	227	Average
2496	59.37	65.8	74	-14.63	27.2	3.62	37.25	100	227	Peak
4804	40.12	56.5	54	-13.88	30.97	5.75	53.1	129	128	Average
4804	48.59	64.97	74	-25.41	30.97	5.75	53.1	129	128	Peak

ANTENNA POLARITY & TEST DISTANCE: VERTICAL AT 3 M

FREQ. (MHz)	EMISSION LEVEL (dBuV/m)	READ LEVEL (dBuV)	LIMIT (dBuV/m)	MARGIN (dB)	ANTENNA FACTOR (dB/m)	CABLE LOSS (dB)	PREAMP FACTOR (dB)	ANTENNA HEIGHT (cm)	TABLE ANGLE (Degree)	REMARK
2388	33.08	40.13	54	-20.92	26.91	3.54	37.5	139	339	Average
2388	59.9	66.95	74	-14.1	26.91	3.54	37.5	139	339	Peak
2480	82.99	89.56			27.15	3.6	37.32	139	339	Average
2480	96.76	103.33			27.15	3.6	37.32	139	339	Peak
2496	36.13	42.56	54	-17.87	27.2	3.62	37.25	139	339	Average
2496	59.29	65.72	74	-14.71	27.2	3.62	37.25	139	339	Peak
4804	37.41	53.79	54	-16.59	30.97	5.75	53.1	111	192	Average
4804	45.77	62.15	74	-28.23	30.97	5.75	53.1	111	192	Peak

REMARKS:

- Emission Level = Read Level + Antenna Factor + Cable Loss - Preamp Factor
Margin value = Emission level – Limit value
- 2480MHz: Fundamental frequency.



A D T

Mode B

EUT TEST CONDITION		MEASUREMENT DETAIL	
CHANNEL	Channel 0	FREQUENCY RANGE	1GHz ~ 25GHz
INPUT POWER	120Vac, 60 Hz	DETECTOR FUNCTION	Peak (PK) Average (AV)
ENVIRONMENTAL CONDITIONS	25deg. C, 65%RH	TESTED BY	Toby Tian

ANTENNA POLARITY & TEST DISTANCE: HORIZONTAL AT 3 M										
FREQ. (MHz)	EMISSION LEVEL (dBuV/m)	READ LEVEL (dBuV)	LIMIT (dBuV/m)	MARGIN (dB)	ANTENNA FACTOR (dB/m)	CABLE LOSS (dB)	PREAMP FACTOR (dB)	ANTENNA HEIGHT (cm)	TABLE ANGLE (Degree)	REMARK
2390	34.79	41.86	54	-19.21	26.91	3.54	37.52	102	227	Average
2390	59.82	66.89	74	-14.18	26.91	3.54	37.52	102	227	Peak
2402	84.47	91.54			26.91	3.54	37.52	102	227	Average
2402	98.51	105.58			26.91	3.54	37.52	102	227	Peak
2496	33.92	40.35	54	-20.08	27.2	3.62	37.25	102	227	Average
2496	56.92	63.35	74	-17.08	27.2	3.62	37.25	102	227	Peak
4804	43.72	60.1	54	-10.28	30.97	5.75	53.1	101	179	Average
4804	52.43	68.81	74	-21.57	30.97	5.75	53.1	101	179	Peak
ANTENNA POLARITY & TEST DISTANCE: VERTICAL AT 3 M										
FREQ. (MHz)	EMISSION LEVEL (dBuV/m)	READ LEVEL (dBuV)	LIMIT (dBuV/m)	MARGIN (dB)	ANTENNA FACTOR (dB/m)	CABLE LOSS (dB)	PREAMP FACTOR (dB)	ANTENNA HEIGHT (cm)	TABLE ANGLE (Degree)	REMARK
2378	33.98	41.1	54	-20.02	26.86	3.52	37.5	123	197	Average
2378	56.99	64.11	74	-17.01	26.86	3.52	37.5	123	197	Peak
2402	83.74	90.81			26.91	3.54	37.52	123	197	Average
2402	97.57	104.64			26.91	3.54	37.52	123	197	Peak
2488	33.63	40.13	54	-20.37	27.2	3.62	37.32	123	197	Average
2488	56.51	63.01	74	-17.49	27.2	3.62	37.32	123	197	Peak
4804	42.43	58.81	54	-11.57	30.97	5.75	53.1	123	172	Average
4804	50.85	67.23	74	-23.15	30.97	5.75	53.1	123	172	Peak

REMARKS:

- Emission Level = Read Level + Antenna Factor + Cable Loss - Preamp Factor
Margin value = Emission level – Limit value
- 2402MHz: Fundamental frequency.



A D T

EUT TEST CONDITION		MEASUREMENT DETAIL	
CHANNEL	Channel 39	FREQUENCY RANGE	1GHz ~ 25GHz
INPUT POWER	120Vac, 60 Hz	DETECTOR FUNCTION	Peak (PK) Average (AV)
ENVIRONMENTAL CONDITIONS	25deg. C, 65%RH	TESTED BY	Toby Tian

ANTENNA POLARITY & TEST DISTANCE: HORIZONTAL AT 3 M

FREQ. (MHz)	EMISSION LEVEL (dBuV/m)	READ LEVEL (dBuV)	LIMIT (dBuV/m)	MARGIN (dB)	ANTENNA FACTOR (dB/m)	CABLE LOSS (dB)	PREAMP FACTOR (dB)	ANTENNA HEIGHT (cm)	TABLE ANGLE (Degree)	REMARK
2312	32.87	40.19	54	-21.13	26.67	3.46	37.45	100	227	Average
2312	56.56	63.88	74	-17.44	26.67	3.46	37.45	100	227	Peak
2441	84.76	91.51			27.06	3.58	37.39	100	227	Average
2441	99.85	106.6			27.06	3.58	37.39	100	227	Peak
2488	33.78	40.28	54	-20.22	27.2	3.62	37.32	100	227	Average
2488	56.69	63.19	74	-17.31	27.2	3.62	37.32	100	227	Peak
4882	43.41	59.6	54	-10.59	31.06	5.8	53.05	113	156	Average
4882	51.71	67.9	74	-22.29	31.06	5.8	53.05	113	156	Peak

ANTENNA POLARITY & TEST DISTANCE: VERTICAL AT 3 M

FREQ. (MHz)	EMISSION LEVEL (dBuV/m)	READ LEVEL (dBuV)	LIMIT (dBuV/m)	MARGIN (dB)	ANTENNA FACTOR (dB/m)	CABLE LOSS (dB)	PREAMP FACTOR (dB)	ANTENNA HEIGHT (cm)	TABLE ANGLE (Degree)	REMARK
2340	32.99	40.21	54	-21.01	26.77	3.5	37.49	122	198	Average
2340	56.4	63.62	74	-17.6	26.77	3.5	37.49	122	198	Peak
2441	81.77	88.52			27.06	3.58	37.39	122	198	Average
2441	94.9	101.65			27.06	3.58	37.39	122	198	Peak
2486	33.55	40.12	54	-20.45	27.15	3.6	37.32	122	198	Average
2486	55.73	62.3	74	-18.27	27.15	3.6	37.32	122	198	Peak
4882	41.16	57.35	54	-12.84	31.06	5.8	53.05	108	167	Average
4882	49.44	65.63	74	-24.56	31.06	5.8	53.05	108	167	Peak

REMARKS:

- Emission Level = Read Level + Antenna Factor + Cable Loss - Preamp Factor
Margin value = Emission level – Limit value
- 2441MHz: Fundamental frequency.



A D T

EUT TEST CONDITION		MEASUREMENT DETAIL	
CHANNEL	Channel 78	FREQUENCY RANGE	1GHz ~ 25GHz
INPUT POWER	120Vac, 60 Hz	DETECTOR FUNCTION	Peak (PK) Average (AV)
ENVIRONMENTAL CONDITIONS	25deg. C, 65%RH	TESTED BY	Toby Tian

ANTENNA POLARITY & TEST DISTANCE: HORIZONTAL AT 3 M

FREQ. (MHz)	EMISSION LEVEL (dBuV/m)	READ LEVEL (dBuV)	LIMIT (dBuV/m)	MARGIN (dB)	ANTENNA FACTOR (dB/m)	CABLE LOSS (dB)	PREAMP FACTOR (dB)	ANTENNA HEIGHT (cm)	TABLE ANGLE (Degree)	REMARK
2354	32.97	40.15	54	-21.03	26.81	3.5	37.49	100	239	Average
2354	55.9	63.08	74	-18.1	26.81	3.5	37.49	100	239	Peak
2480	85.21	91.78			27.15	3.6	37.32	100	239	Average
2480	99.39	105.96			27.15	3.6	37.32	100	239	Peak
2488	37.57	44.07	54	-16.43	27.2	3.62	37.32	100	239	Average
2488	57.52	64.02	74	-16.48	27.2	3.62	37.32	100	239	Peak
4960	43.16	59.2	54	-10.84	31.16	5.84	53.04	110	158	Average
4960	51.41	67.45	74	-22.59	31.16	5.84	53.04	110	158	Peak

ANTENNA POLARITY & TEST DISTANCE: VERTICAL AT 3 M

FREQ. (MHz)	EMISSION LEVEL (dBuV/m)	READ LEVEL (dBuV)	LIMIT (dBuV/m)	MARGIN (dB)	ANTENNA FACTOR (dB/m)	CABLE LOSS (dB)	PREAMP FACTOR (dB)	ANTENNA HEIGHT (cm)	TABLE ANGLE (Degree)	REMARK
2326	32.88	40.15	54	-21.12	26.72	3.48	37.47	120	185	Average
2326	56.38	63.65	74	-17.62	26.72	3.48	37.47	120	185	Peak
2480	81.44	88.01			27.15	3.6	37.32	120	185	Average
2480	94.59	101.16			27.15	3.6	37.32	120	185	Peak
2484	35.33	41.9	54	-18.67	27.15	3.6	37.32	120	185	Average
2484	57.01	63.58	74	-16.99	27.15	3.6	37.32	120	185	Peak
4960	41.81	57.85	54	-12.19	31.16	5.84	53.04	104	144	Average
4960	49.32	65.36	74	-24.68	31.16	5.84	53.04	104	144	Peak

REMARKS:

- Emission Level = Read Level + Antenna Factor + Cable Loss - Preamp Factor
Margin value = Emission level – Limit value
- 2480MHz: Fundamental frequency.



A D T

BELOW 1GHz WORST-CASE DATA:

Mode A

EUT TEST CONDITION		MEASUREMENT DETAIL	
CHANNEL	Channel 0	FREQUENCY RANGE	30MHz ~ 1GHz
INPUT POWER	120Vac, 60 Hz	DETECTOR FUNCTION	Peak (PK)
ENVIRONMENTAL CONDITIONS	25deg. C, 65%RH	TESTED BY	Toby Tian

ANTENNA POLARITY & TEST DISTANCE: HORIZONTAL AT 3 M

FREQ. (MHz)	EMISSION LEVEL (dBuV/m)	READ LEVEL (dBuV)	LIMIT (dBuV/m)	MARGIN (dB)	ANTENNA FACTOR (dB/m)	CABLE LOSS (dB)	PREAMP FACTOR (dB)	ANTENNA HEIGHT (cm)	TABLE ANGLE (Degree)	REMARK
135.57	25.49	43.88	43.5	-18.01	12.08	1.27	31.74	101	54	Peak
173.37	23.66	42.59	43.5	-19.84	11.38	1.46	31.77	111	31	Peak
199.02	23.53	44.27	43.5	-19.97	9.43	1.59	31.76	100	241	Peak
654.2	22.91	31.37	46	-23.09	20.27	3.26	31.99	130	140	Peak
734	24.46	31.18	46	-21.54	21.3	3.53	31.55	106	81	Peak
771.1	25.91	31.78	46	-20.09	21.82	3.62	31.31	123	299	Peak

ANTENNA POLARITY & TEST DISTANCE: VERTICAL AT 3 M

FREQ. (MHz)	EMISSION LEVEL (dBuV/m)	READ LEVEL (dBuV)	LIMIT (dBuV/m)	MARGIN (dB)	ANTENNA FACTOR (dB/m)	CABLE LOSS (dB)	PREAMP FACTOR (dB)	ANTENNA HEIGHT (cm)	TABLE ANGLE (Degree)	REMARK
134.76	25.28	43.76	43.5	-18.22	12.01	1.27	31.76	111	330	Peak
190.92	22.19	42.34	43.5	-21.31	9.98	1.55	31.68	129	36	Peak
199.02	23.18	43.92	43.5	-20.32	9.43	1.59	31.76	126	105	Peak
661.2	22.94	31.22	46	-23.06	20.35	3.29	31.92	122	122	Peak
734	25.22	31.94	46	-20.78	21.3	3.53	31.55	128	75	Peak
769	26.32	32.22	46	-19.68	21.79	3.62	31.31	132	82	Peak

REMARKS: Emission Level = Read Level + Antenna Factor + Cable Loss - Preamp Factor

Margin value = Emission level – Limit value



A D T

EUT TEST CONDITION		MEASUREMENT DETAIL	
CHANNEL	Channel 39	FREQUENCY RANGE	30MHz ~ 1GHz
INPUT POWER	120Vac, 60 Hz	DETECTOR FUNCTION	Peak (PK)
ENVIRONMENTAL CONDITIONS	25deg. C, 65%RH	TESTED BY	Toby Tian

ANTENNA POLARITY & TEST DISTANCE: HORIZONTAL AT 3 M

FREQ. (MHz)	EMISSION LEVEL (dBuV/m)	READ LEVEL (dBuV)	LIMIT (dBuV/m)	MARGIN (dB)	ANTENNA FACTOR (dB/m)	CABLE LOSS (dB)	PREAMP FACTOR (dB)	ANTENNA HEIGHT (cm)	TABLE ANGLE (Degree)	REMARK
140.16	25.08	43.05	43.5	-18.42	12.37	1.3	31.64	138	293	Peak
169.86	22.83	41.36	43.5	-20.67	11.76	1.44	31.73	139	89	Peak
201.72	23.58	44.28	43.5	-19.92	9.44	1.6	31.74	108	322	Peak
588.4	22.26	32	46	-23.74	19.34	3.06	32.14	132	272	Peak
677.3	23.33	31.28	46	-22.67	20.54	3.34	31.83	133	325	Peak
745.2	24.77	31.15	46	-21.23	21.45	3.56	31.39	110	214	Peak

ANTENNA POLARITY & TEST DISTANCE: VERTICAL AT 3 M

FREQ. (MHz)	EMISSION LEVEL (dBuV/m)	READ LEVEL (dBuV)	LIMIT (dBuV/m)	MARGIN (dB)	ANTENNA FACTOR (dB/m)	CABLE LOSS (dB)	PREAMP FACTOR (dB)	ANTENNA HEIGHT (cm)	TABLE ANGLE (Degree)	REMARK
136.11	24.26	42.65	43.5	-19.24	12.08	1.27	31.74	105	55	Peak
161.76	22.65	40.56	43.5	-20.85	12.54	1.4	31.85	122	256	Peak
174.18	22.88	41.91	43.5	-20.62	11.28	1.47	31.78	114	16	Peak
644.4	22.87	31.57	46	-23.13	20.14	3.22	32.06	108	340	Peak
742.4	25.09	31.57	46	-20.91	21.41	3.55	31.44	134	39	Peak
780.2	26.38	32.22	46	-19.62	21.94	3.65	31.43	121	185	Peak

REMARKS: Emission Level = Read Level + Antenna Factor + Cable Loss - Preamp Factor
 Margin value = Emission level – Limit value



A D T

EUT TEST CONDITION		MEASUREMENT DETAIL	
CHANNEL	Channel 78	FREQUENCY RANGE	30MHz ~ 1GHz
INPUT POWER	120Vac, 60 Hz	DETECTOR FUNCTION	Peak (PK)
ENVIRONMENTAL CONDITIONS	25deg. C, 65%RH	TESTED BY	Toby Tian

ANTENNA POLARITY & TEST DISTANCE: HORIZONTAL AT 3 M

FREQ. (MHz)	EMISSION LEVEL (dBuV/m)	READ LEVEL (dBuV)	LIMIT (dBuV/m)	MARGIN (dB)	ANTENNA FACTOR (dB/m)	CABLE LOSS (dB)	PREAMP FACTOR (dB)	ANTENNA HEIGHT (cm)	TABLE ANGLE (Degree)	REMARK
136.38	25.75	44.04	43.5	-17.75	12.14	1.28	31.71	113	182	Peak
146.91	24.93	42.61	43.5	-18.57	12.61	1.33	31.62	128	235	Peak
172.29	22	40.83	43.5	-21.5	11.47	1.46	31.76	113	342	Peak
563.2	22.13	32.44	46	-23.87	18.77	2.99	32.07	107	69	Peak
647.2	23.15	31.79	46	-22.85	20.17	3.23	32.04	117	17	Peak
681.5	25.01	32.89	46	-20.99	20.6	3.36	31.84	115	103	Peak

ANTENNA POLARITY & TEST DISTANCE: VERTICAL AT 3 M

FREQ. (MHz)	EMISSION LEVEL (dBuV/m)	READ LEVEL (dBuV)	LIMIT (dBuV/m)	MARGIN (dB)	ANTENNA FACTOR (dB/m)	CABLE LOSS (dB)	PREAMP FACTOR (dB)	ANTENNA HEIGHT (cm)	TABLE ANGLE (Degree)	REMARK
31.35	23.02	41.43	40	-16.98	12.14	0.57	31.12	116	12	Peak
37.83	22.5	39.65	40	-17.5	13.24	0.63	31.02	139	5	Peak
138	26.06	44.26	43.5	-17.44	12.21	1.28	31.69	138	272	Peak
575.1	21.92	31.97	46	-24.08	19.03	3.02	32.1	140	183	Peak
646.5	24.37	33.01	46	-21.63	20.17	3.23	32.04	128	358	Peak
694.1	24.19	31.85	46	-21.81	20.75	3.41	31.82	111	132	Peak

REMARKS: Emission Level = Read Level + Antenna Factor + Cable Loss - Preamp Factor

Margin value = Emission level – Limit value



A D T

Mode B

EUT TEST CONDITION		MEASUREMENT DETAIL	
CHANNEL	Channel 0	FREQUENCY RANGE	30MHz ~ 1GHz
INPUT POWER	120Vac, 60 Hz	DETECTOR FUNCTION	Peak (PK)
ENVIRONMENTAL CONDITIONS	25deg. C, 65%RH	TESTED BY	Toby Tian

ANTENNA POLARITY & TEST DISTANCE: HORIZONTAL AT 3 M										
FREQ. (MHz)	EMISSION LEVEL (dBuV/m)	READ LEVEL (dBuV)	LIMIT (dBuV/m)	MARGIN (dB)	ANTENNA FACTOR (dB/m)	CABLE LOSS (dB)	PREAMP FACTOR (dB)	ANTENNA HEIGHT (cm)	TABLE ANGLE (Degree)	REMARK
79.95	19.6	41.8	40	-20.4	8.37	0.97	31.54	114	206	Peak
127.47	26.23	45.42	43.5	-17.27	11.48	1.22	31.89	128	51	Peak
188.22	28.22	48.19	43.5	-15.28	10.19	1.54	31.7	115	263	Peak
309.1	21.05	37.74	46	-24.95	13.17	2.08	31.94	122	154	Peak
393.8	21.24	35.73	46	-24.76	15.19	2.4	32.08	128	315	Peak
538	24.33	34.95	46	-21.67	18.19	2.91	31.72	104	314	Peak

ANTENNA POLARITY & TEST DISTANCE: VERTICAL AT 3 M										
FREQ. (MHz)	EMISSION LEVEL (dBuV/m)	READ LEVEL (dBuV)	LIMIT (dBuV/m)	MARGIN (dB)	ANTENNA FACTOR (dB/m)	CABLE LOSS (dB)	PREAMP FACTOR (dB)	ANTENNA HEIGHT (cm)	TABLE ANGLE (Degree)	REMARK
31.89	23.14	41.37	40	-16.86	12.3	0.58	31.11	113	348	Peak
79.68	30.98	53.18	40	-9.02	8.37	0.97	31.54	102	197	Peak
126.93	30.89	50.08	43.5	-12.61	11.48	1.22	31.89	103	267	Peak
313.3	17.89	34.46	46	-28.11	13.26	2.1	31.93	139	328	Peak
436.5	20.61	33.99	46	-25.39	16.06	2.56	32	105	169	Peak
584.9	25.49	35.32	46	-20.51	19.26	3.04	32.13	128	137	Peak

REMARKS: Emission Level = Read Level + Antenna Factor + Cable Loss - Preamp Factor
Margin value = Emission level – Limit value



A D T

EUT TEST CONDITION		MEASUREMENT DETAIL	
CHANNEL	Channel 39	FREQUENCY RANGE	30MHz ~ 1GHz
INPUT POWER	120Vac, 60 Hz	DETECTOR FUNCTION	Peak (PK)
ENVIRONMENTAL CONDITIONS	25deg. C, 65%RH	TESTED BY	Toby Tian

ANTENNA POLARITY & TEST DISTANCE: HORIZONTAL AT 3 M										
FREQ. (MHz)	EMISSION LEVEL (dBuV/m)	READ LEVEL (dBuV)	LIMIT (dBuV/m)	MARGIN (dB)	ANTENNA FACTOR (dB/m)	CABLE LOSS (dB)	PREAMP FACTOR (dB)	ANTENNA HEIGHT (cm)	TABLE ANGLE (Degree)	REMARK
83.46	19.18	41.66	40	-20.82	8.18	0.99	31.65	140	317	Peak
127.74	25.83	44.93	43.5	-17.67	11.55	1.23	31.88	123	272	Peak
186.87	27.63	47.56	43.5	-15.87	10.26	1.53	31.72	102	188	Peak
318.2	20.34	36.74	46	-25.66	13.38	2.12	31.9	105	104	Peak
393.8	20.87	35.36	46	-25.13	15.19	2.4	32.08	100	109	Peak
573.7	22.12	32.19	46	-23.88	19.01	3.02	32.1	118	295	Peak

ANTENNA POLARITY & TEST DISTANCE: VERTICAL AT 3 M										
FREQ. (MHz)	EMISSION LEVEL (dBuV/m)	READ LEVEL (dBuV)	LIMIT (dBuV/m)	MARGIN (dB)	ANTENNA FACTOR (dB/m)	CABLE LOSS (dB)	PREAMP FACTOR (dB)	ANTENNA HEIGHT (cm)	TABLE ANGLE (Degree)	REMARK
30	25.55	44.14	40	-14.45	11.98	0.57	31.14	105	71	Peak
83.19	28.52	51	40	-11.48	8.18	0.99	31.65	107	147	Peak
128.82	27.32	46.36	43.5	-16.18	11.61	1.23	31.88	113	144	Peak
323.1	17.27	33.51	46	-28.73	13.5	2.13	31.87	140	329	Peak
479.2	24.1	36.33	46	-21.9	16.91	2.71	31.85	111	320	Peak
605.9	24.84	34.2	46	-21.16	19.68	3.11	32.15	132	158	Peak

REMARKS: Emission Level = Read Level + Antenna Factor + Cable Loss - Preamp Factor
 Margin value = Emission level – Limit value



A D T

EUT TEST CONDITION		MEASUREMENT DETAIL	
CHANNEL	Channel 78	FREQUENCY RANGE	30MHz ~ 1GHz
INPUT POWER	120Vac, 60 Hz	DETECTOR FUNCTION	Peak (PK)
ENVIRONMENTAL CONDITIONS	25deg. C, 65%RH	TESTED BY	Toby Tian

ANTENNA POLARITY & TEST DISTANCE: HORIZONTAL AT 3 M										
FREQ. (MHz)	EMISSION LEVEL (dBuV/m)	READ LEVEL (dBuV)	LIMIT (dBuV/m)	MARGIN (dB)	ANTENNA FACTOR (dB/m)	CABLE LOSS (dB)	PREAMP FACTOR (dB)	ANTENNA HEIGHT (cm)	TABLE ANGLE (Degree)	REMARK
79.95	18.38	40.58	40	-21.62	8.37	0.97	31.54	118	340	Peak
126.93	26.24	45.43	43.5	-17.26	11.48	1.22	31.89	102	204	Peak
194.7	28.02	48.47	43.5	-15.48	9.7	1.57	31.72	118	179	Peak
319.6	21.24	37.58	46	-24.76	13.43	2.12	31.89	122	213	Peak
415.5	21.03	34.93	46	-24.97	15.64	2.48	32.02	104	42	Peak
541.5	21.87	32.44	46	-24.13	18.26	2.92	31.75	107	295	Peak

ANTENNA POLARITY & TEST DISTANCE: VERTICAL AT 3 M										
FREQ. (MHz)	EMISSION LEVEL (dBuV/m)	READ LEVEL (dBuV)	LIMIT (dBuV/m)	MARGIN (dB)	ANTENNA FACTOR (dB/m)	CABLE LOSS (dB)	PREAMP FACTOR (dB)	ANTENNA HEIGHT (cm)	TABLE ANGLE (Degree)	REMARK
30	25.46	44.05	40	-14.54	11.98	0.57	31.14	128	296	Peak
79.41	29.39	51.59	40	-10.61	8.37	0.97	31.54	131	344	Peak
119.64	27.91	47.69	43.5	-15.59	10.93	1.18	31.89	102	71	Peak
347.6	17.83	33.36	46	-28.17	14.08	2.22	31.83	111	359	Peak
479.2	23.32	35.55	46	-22.68	16.91	2.71	31.85	118	206	Peak
619.2	23.84	33.03	46	-22.16	19.83	3.14	32.16	104	274	Peak

REMARKS: Emission Level = Read Level + Antenna Factor + Cable Loss - Preamp Factor
 Margin value = Emission level – Limit value

4.2 CONDUCTED EMISSION MEASUREMENT

4.2.1 LIMITS OF CONDUCTED EMISSION MEASUREMENT

FREQUENCY OF EMISSION (MHz)	CONDUCTED LIMIT (dB μ V)	
	Quasi-peak	Average
0.15 ~ 0.5	66 to 56	56 to 46
0.5 ~ 5	56	46
5 ~ 30	60	50

- NOTE:**
1. The lower limit shall apply at the transition frequencies.
 2. The limit decreases in line with the logarithm of the frequency in the range of 0.15 to 0.50MHz.
 3. All emanations from a class A/B digital device or system, including any network of conductors and apparatus connected thereto, shall not exceed the level of field strengths specified above.

4.2.2 TEST INSTRUMENTS

DESCRIPTION & MANUFACTURER	MODEL NO.	SERIAL NO.	DATE OF CALIBRATION	DUE DATE OF CALIBRATION
Test Receiver ROHDE & SCHWARZ	ESCI	100613	Nov. 11, 2014	Nov. 10, 2015
RF signal cable Woken	5D-FB	Cable-HYC01-01	Dec. 26, 2014	Dec. 25, 2015
LISN ROHDE & SCHWARZ (EUT)	ESH3-Z5	835239/001	Mar. 02, 2015	Mar. 01, 2016
LISN ROHDE & SCHWARZ (Peripheral)	ESH3-Z5	100311	Jul. 21, 2014	Jul. 20, 2015
Software ADT	BV ADT_Cond_ V7.3.7.3	NA	NA	NA

- NOTE:**
1. The calibration interval of the above test instruments is 12 months and the calibrations are traceable to NML/ROC and NIST/USA.
 2. The test was performed in HwaYa Shielded Room 1.
 3. The VCCI Site Registration No. is C-2047.



A D T

4.2.3 TEST PROCEDURES

- a. The EUT was placed 0.4 meters from the conducting wall of the shielded room with EUT being connected to the power mains through a line impedance stabilization network (LISN). Other support units were connected to the power mains through another LISN. The two LISNs provide 50 ohm/ 50uH of coupling impedance for the measuring instrument.
- b. Both lines of the power mains connected to the EUT were checked for maximum conducted interference.
- c. The frequency range from 150kHz to 30MHz was searched. Emission levels under (Limit - 20dB) was not recorded.

NOTE: All modes of operation were investigated and the worst-case emissions are reported.

4.2.4 DEVIATION FROM TEST STANDARD

No deviation.

4.2.5 TEST SETUP

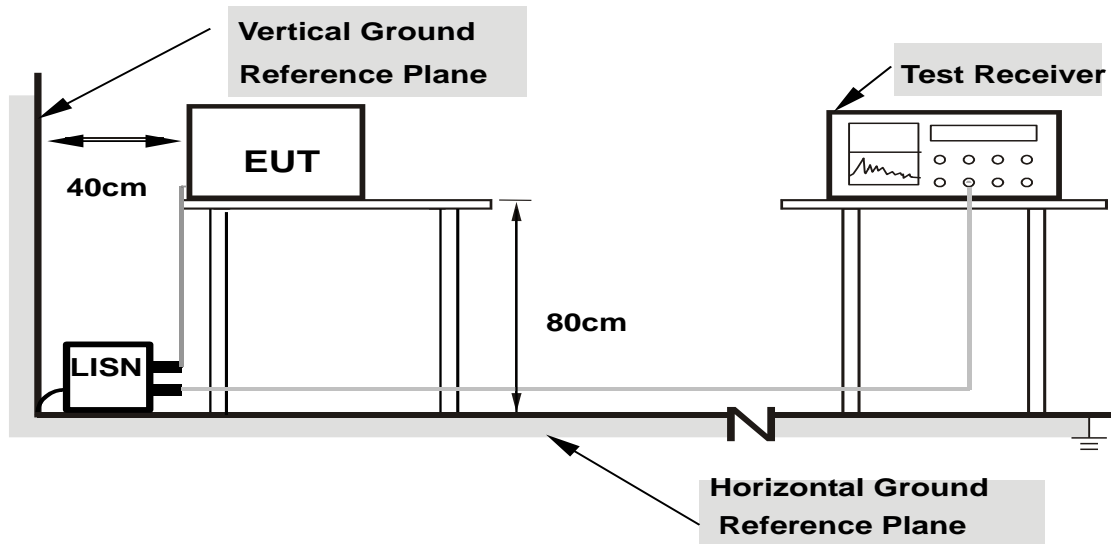

- Note:**
1. Support units were connected to second LISN.
 2. Both of LISNs (AMN) are 80 cm from EUT and at least 80 from other units and other metal planes

For the actual test configuration, please refer to the attached file (Test Setup Photo).

4.2.6 EUT OPERATING CONDITIONS

Same as section 4.1.6.

4.2.7 TEST RESULTS

CONDUCTED WORST-CASE DATA :

Mode A

PHASE	Line 1	6dB BANDWIDTH	9kHz
FUNCTION TYPE	BT Tx + Adapter + USB Cable + Earphone		

No	Frequency (MHz)	Correction Factor (dB)	Reading Value (dBuV)		Emission Level (dBuV)		Limit (dBuV)		Margin (dB)	
			Q.P.	AV.	Q.P.	AV.	Q.P.	AV.	Q.P.	AV.
1	0.16139	0.05	48.10	31.46	48.15	31.51	65.39	55.39	-17.24	-23.88
2	0.16967	0.05	48.54	31.85	48.59	31.90	64.98	54.98	-16.38	-23.07
3	0.20458	0.06	45.27	28.83	45.33	28.89	63.42	53.42	-18.09	-24.53
4	0.25948	0.06	37.28	25.73	37.34	25.79	61.45	51.45	-24.11	-25.66
5	0.34469	0.06	39.03	27.23	39.09	27.29	59.09	49.09	-20.00	-21.80
6	1.05321	0.08	37.02	27.81	37.10	27.89	56.00	46.00	-18.90	-18.11

Remarks:

1. Q.P. and AV. are abbreviations of quasi-peak and average individually.
2. The emission levels of other frequencies were very low against the limit.
3. Margin value = Emission level – Limit value
4. Correction factor = Insertion loss + Cable loss
5. Emission Level = Correction Factor + Reading Value

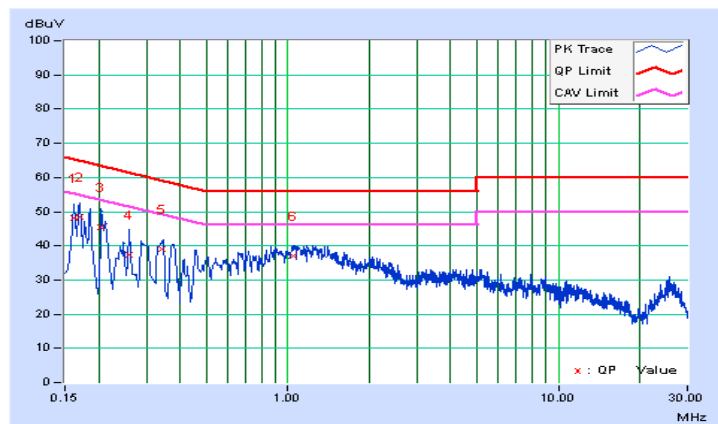



A D T

PHASE	Line 2	6dB BANDWIDTH	9kHz
FUNCTION TYPE	BT Tx + Adapter + USB Cable + Earphone		

No	Frequency (MHz)	Correction Factor (dB)	Reading Value (dBuV)		Emission Level (dBuV)		Limit (dBuV)		Margin (dB)	
			Q.P.	AV.	Q.P.	AV.	Q.P.	AV.	Q.P.	AV.
1	0.15782	0.05	43.32	29.02	43.37	29.07	65.58	55.58	-22.21	-26.51
2	0.25557	0.05	40.33	29.16	40.38	29.21	61.57	51.57	-21.19	-22.36
3	0.29043	0.05	44.98	38.80	45.03	38.85	60.51	50.51	-15.48	-11.66
4	0.37206	0.06	43.60	38.16	43.66	38.22	58.45	48.45	-14.80	-10.24
5	1.03757	0.08	37.87	29.81	37.95	29.89	56.00	46.00	-18.05	-16.11
6	1.75701	0.10	37.24	29.09	37.34	29.19	56.00	46.00	-18.66	-16.81

Remarks:

1. Q.P. and AV. are abbreviations of quasi-peak and average individually.
2. The emission levels of other frequencies were very low against the limit.
3. Margin value = Emission level – Limit value
4. Correction factor = Insertion loss + Cable loss
5. Emission Level = Correction Factor + Reading Value

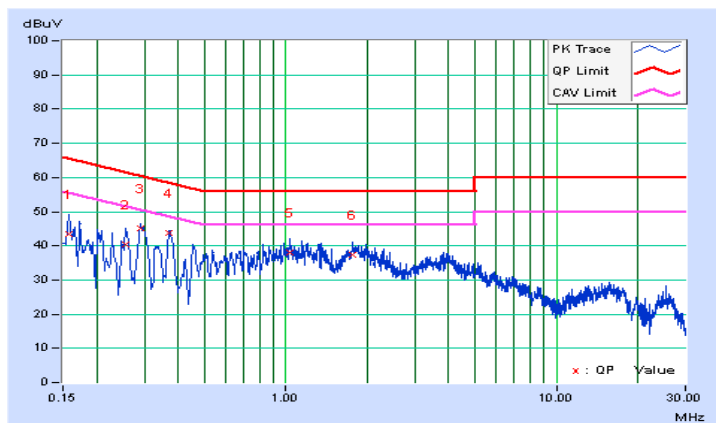

Mode B

PHASE	Line 1	6dB BANDWIDTH	9kHz
FUNCTION TYPE	BT Tx + Adapter + USB Cable + Earphone		

No	Frequency (MHz)	Correction Factor (dB)	Reading Value (dBuV)		Emission Level (dBuV)		Limit (dBuV)		Margin (dB)	
			Q.P.	AV.	Q.P.	AV.	Q.P.	AV.	Q.P.	AV.
1	0.16181	0.05	44.11	30.74	44.16	30.79	65.37	55.37	-21.21	-24.58
2	0.20458	0.06	43.50	30.90	43.56	30.96	63.42	53.42	-19.86	-22.46
3	0.29120	0.06	41.45	36.80	41.51	36.86	60.49	50.49	-18.98	-13.63
4	0.37108	0.06	40.75	35.88	40.81	35.94	58.48	48.48	-17.67	-12.54
5	0.86913	0.08	39.49	31.71	39.57	31.79	56.00	46.00	-16.43	-14.21
6	1.03421	0.08	40.16	31.96	40.24	32.04	56.00	46.00	-15.76	-13.96

Remarks:

1. Q.P. and AV. are abbreviations of quasi-peak and average individually.
2. The emission levels of other frequencies were very low against the limit.
3. Margin value = Emission level – Limit value
4. Correction factor = Insertion loss + Cable loss
5. Emission Level = Correction Factor + Reading Value

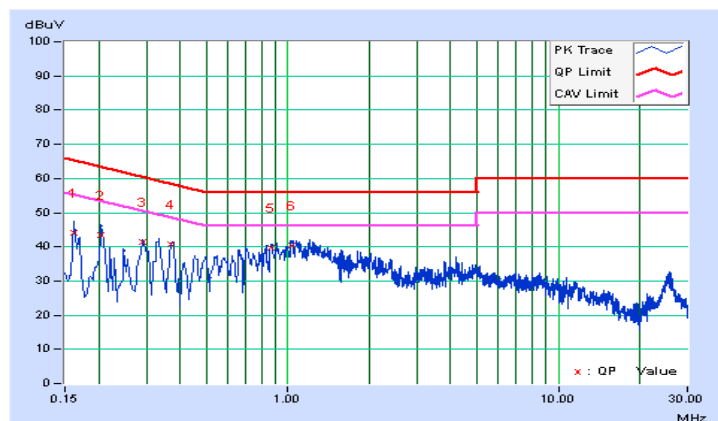



A D T

PHASE	Line 2	6dB BANDWIDTH	9kHz
FUNCTION TYPE	BT Tx + Adapter + USB Cable + Earphone		

No	Frequency (MHz)	Correction Factor (dB)	Reading Value (dBuV)		Emission Level (dBuV)		Limit (dBuV)		Margin (dB)	
			Q.P.	AV.	Q.P.	AV.	Q.P.	AV.	Q.P.	AV.
1	0.16139	0.05	44.40	32.71	44.45	32.76	65.39	55.39	-20.94	-22.63
2	0.21282	0.05	39.72	28.52	39.77	28.57	63.09	53.09	-23.32	-24.52
3	0.24384	0.05	41.28	29.75	41.33	29.80	61.96	51.96	-20.63	-22.16
4	0.30249	0.06	42.04	29.03	42.10	29.09	60.17	50.17	-18.08	-21.09
5	0.37287	0.06	44.12	40.17	44.18	40.23	58.44	48.44	-14.26	-8.21
6	0.82643	0.07	39.24	33.10	39.31	33.17	56.00	46.00	-16.69	-12.83

Remarks:

1. Q.P. and AV. are abbreviations of quasi-peak and average individually.
2. The emission levels of other frequencies were very low against the limit.
3. Margin value = Emission level – Limit value
4. Correction factor = Insertion loss + Cable loss
5. Emission Level = Correction Factor + Reading Value

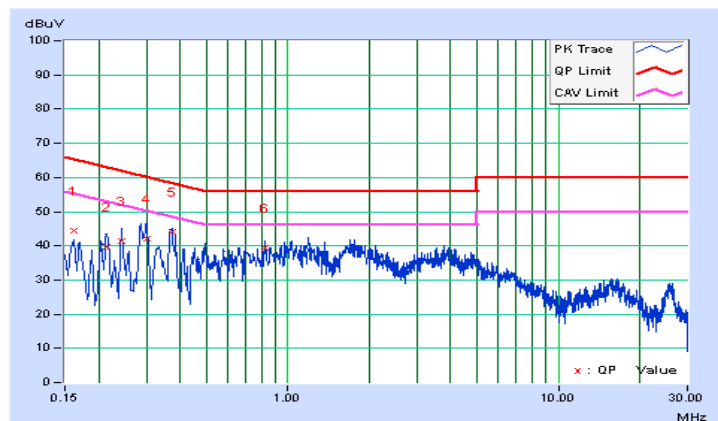

4.3 NUMBER OF HOPPING FREQUENCY USED

4.3.1 LIMIT OF HOPPING FREQUENCY USED

At least 15 channels frequencies, and should be equally spaced.

4.3.2 TEST SETUP

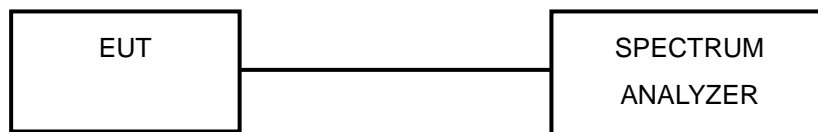

4.3.3 TEST INSTRUMENTS

Refer to section 4.1.2 to get information of above instrument.

4.3.4 TEST PROCEDURE

- Check the calibration of the measuring instrument (SA) using either an internal calibrator or a known signal from an external generator.
- Turn on the EUT and connect its antenna terminal to measurement via a low loss cable. Then set it to any one measured frequency within its operating range and make sure the instrument is operated in its linear range.
- Set the SA on MaxHold Mode, and then keep the EUT in hopping mode. Record all the signals from each channel until each one has been recorded.
- Set the SA on View mode and then plot the result on SA screen.
- Repeat above procedures until all frequencies measured were complete.

4.3.5 DEVIATION FROM TEST STANDARD

No deviation.

4.3.6 TEST RESULTS

There are 79 hopping frequencies in the hopping mode. Please refer to next page for the test result. On the plot, it shows that the hopping frequencies are equally spaced.



A D T

8DPSK

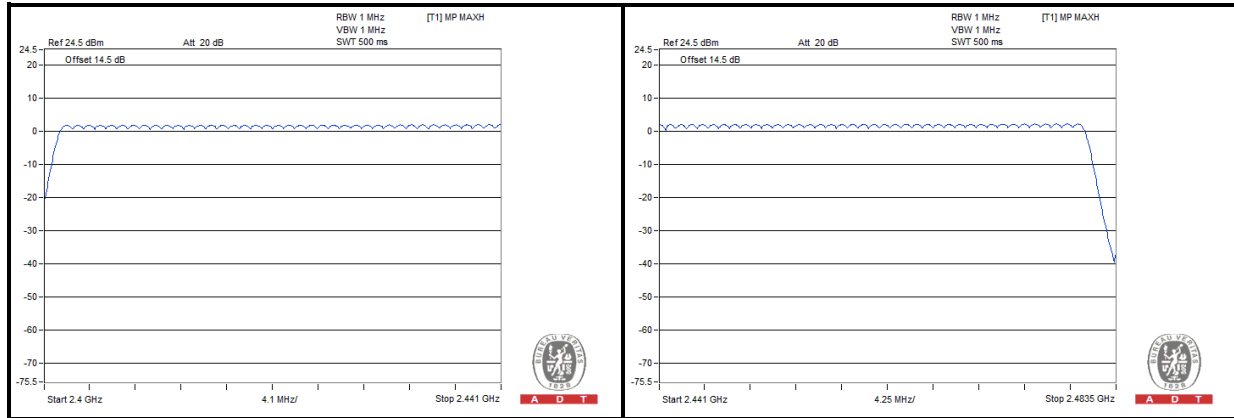

4.4 DWELL TIME ON EACH CHANNEL

4.4.1 LIMITS OF DWELL TIME USED

The average time of occupancy on any channel shall not be greater than 0.4 seconds within a period of 0.4 seconds multiplied by the number of hopping channels employed.

4.4.2 TEST SETUP

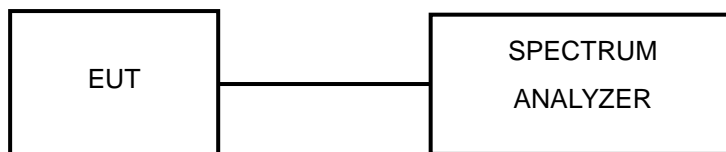

4.4.3 TEST INSTRUMENTS

Refer to section 4.1.2 to get information of above instrument.

4.4.4 TEST PROCEDURES

- a. Check the calibration of the measuring instrument (SA) using either an internal calibrator or a known signal from an external generator.
- b. Turn on the EUT and connect its antenna terminal to measurement via a low loss cable. Then set it to any one measured frequency within its operating range and make sure the instrument is operated in its linear range.
- c. Adjust the center frequency of SA on any frequency be measured and set SA to zero span mode. And then, set RBW and VBW of spectrum analyzer to proper value.
- d. Measure the time duration of one transmission on the measured frequency. And then plot the result with time difference of this time duration.
- e. Repeat above procedures until all different time-slot modes have been completed.

4.4.5 DEVIATION FROM TEST STANDARD

No deviation.



A D T

4.4.6 TEST RESULTS

GFSK

Mode	Average Hopping Channel	Package Transfer Time (usec)	Result (sec)	Limit (sec)
DH1	10.00	452.00	0.14	0.4
DH3	5.40	1674.00	0.29	0.4
DH5	3.20	2948.00	0.30	0.4

NOTE:

1. Dwell Time=79(channels) x 0.4(s) x average hopping channel x package transfer time
2. 79 channels come from the Hopping Channel number
3. Average Hopping Channel = hops/sweep time
4. t: Package Transfer Time(us)
5. Test plots of the transmitting time slot are shown as below.





A D T

π/4-DQPSK

Mode	Average Hopping Channel	Package Transfer Time (usec)	Result (sec)	Limit (sec)
2DH1	10.20	471.00	0.15	0.4
2DH3	5.40	1730.00	0.30	0.4
2DH5	3.20	3004.00	0.30	0.4

NOTE:

1. Dwell Time=79(channels) x 0.4(s) x average hopping channel x package transfer time
2. 79 channels come from the Hopping Channel number
3. Average Hopping Channel = hops/sweep time
4. t: Package Transfer Time(us)
5. Test plots of the transmitting time slot are shown as below.





A D T

8DPSK

Mode	Average Hopping Channel	Package Transfer Time (usec)	Result (sec)	Limit (sec)
3DH1	10.00	457.00	0.14	0.4
3DH3	5.00	1730.00	0.27	0.4
3DH5	3.60	3004.00	0.34	0.4

NOTE:

1. Dwell Time=79(channels) x 0.4(s) x average hopping channel x package transfer time
2. 79 channels come from the Hopping Channel number
3. Average Hopping Channel = hops/sweep time
4. t: Package Transfer Time(us)
5. Test plots of the transmitting time slot are shown as below.



4.5 CHANNEL BANDWIDTH

4.5.1 LIMITS OF CHANNEL BANDWIDTH

For frequency hopping system operating in the 2400-2483.5MHz, If the 20dB bandwidth of hopping channel is greater than 25kHz, two-thirds 20dB bandwidth of hopping channel shall be a minimum limit for the hopping channel separation.

4.5.2 TEST SETUP

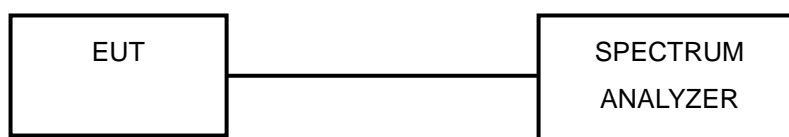

4.5.3 TEST INSTRUMENTS

Refer to section 4.1.2 to get information of above instrument.

4.5.4 TEST PROCEDURE

- a. Check the calibration of the measuring instrument using either an internal calibrator or a known signal from an external generator.
- b. Turn on the EUT and connect it to measurement instrument. Then set it to any one convenient frequency within its operating range. Set a reference level on the measuring instrument equal to the highest peak value.
- c. Measure the frequency difference of two frequencies that were attenuated 20dB from the reference level. Record the frequency difference as the emission bandwidth.
- d. Repeat above procedures until all frequencies measured were complete.

4.5.5 DEVIATION FROM TEST STANDARD

No deviation.

4.5.6 EUT OPERATING CONDITION

The software provided by client enabled the EUT to transmit and receive data at lowest, middle and highest channel frequencies individually.



A D T

4.5.7 TEST RESULTS

CHANNEL	FREQUENCY (MHz)	20dB BANDWIDTH (MHz)		
		GFSK	$\pi/4$ -DQPSK	8DPSK
0	2402	0.93	1.35	1.32
39	2441	0.93	1.34	1.31
78	2480	0.93	1.35	1.31

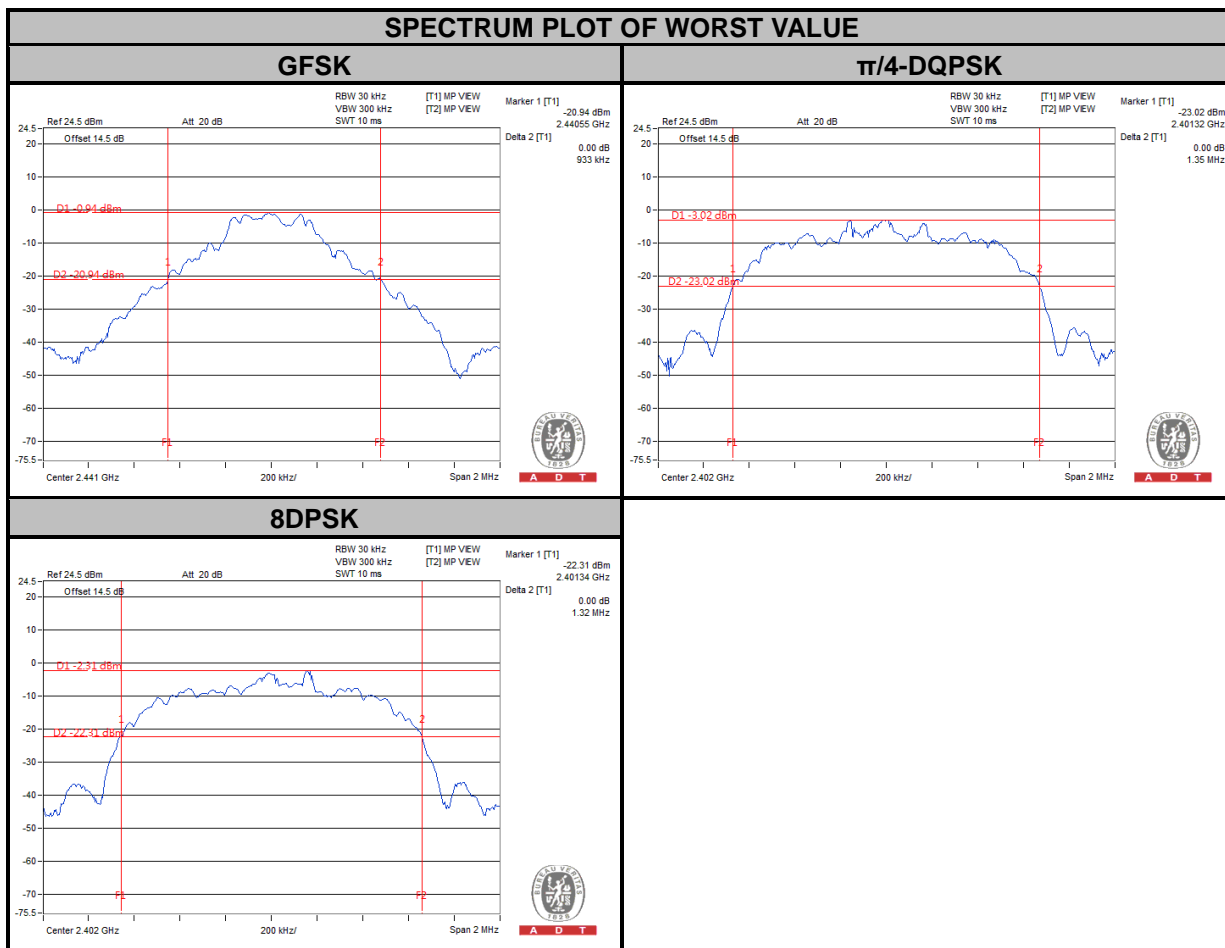

4.6 HOPPING CHANNEL SEPARATION

4.6.1 LIMITS OF HOPPING CHANNEL SEPARATION

At least 25kHz or two-third of 20dB hopping channel bandwidth (whichever is greater).

4.6.2 TEST SETUP

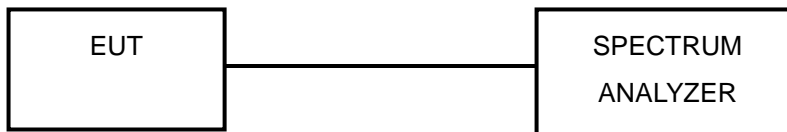

4.6.3 TEST INSTRUMENTS

Refer to section 4.1.2 to get information of above instrument.

4.6.4 TEST PROCEDURE

- a. Check the calibration of the measuring instrument using either an internal calibrator or a known signal from an external generator.
- b. Turn on the EUT and connect it to measurement instrument. Then set it to any one convenient frequency within its operating range.
- c. By using the MaxHold function record the separation of two adjacent channels.
- d. Measure the frequency difference of these two adjacent channels by SA MARK function. And then plot the result on SA screen.
- e. Repeat above procedures until all frequencies measured were complete.

4.6.5 DEVIATION FROM TEST STANDARD

No deviation.



A D T

4.6.6 TEST RESULTS

CHAN.	FREQ. (MHz)	ADJACENT CHANNEL SEPARATION (MHz)			20dB BANDWIDTH (MHz)			MINIMUM LIMIT (MHz)			PASS / FAIL
		GFSK	$\pi/4$ -DQPSK	8DPSK	GFSK	$\pi/4$ -DQPSK	8DPSK	GFSK	$\pi/4$ -DQPSK	8DPSK	
0	2402	1.00	1.10	1.00	0.93	1.35	1.32	0.620	0.900	0.880	PASS
39	2441	1.00	1.00	1.00	0.93	1.34	1.31	0.622	0.893	0.873	PASS
78	2480	1.00	1.10	1.00	0.93	1.35	1.31	0.621	0.900	0.873	PASS

NOTE:

- The minimum limit is two-third 20dB bandwidth.

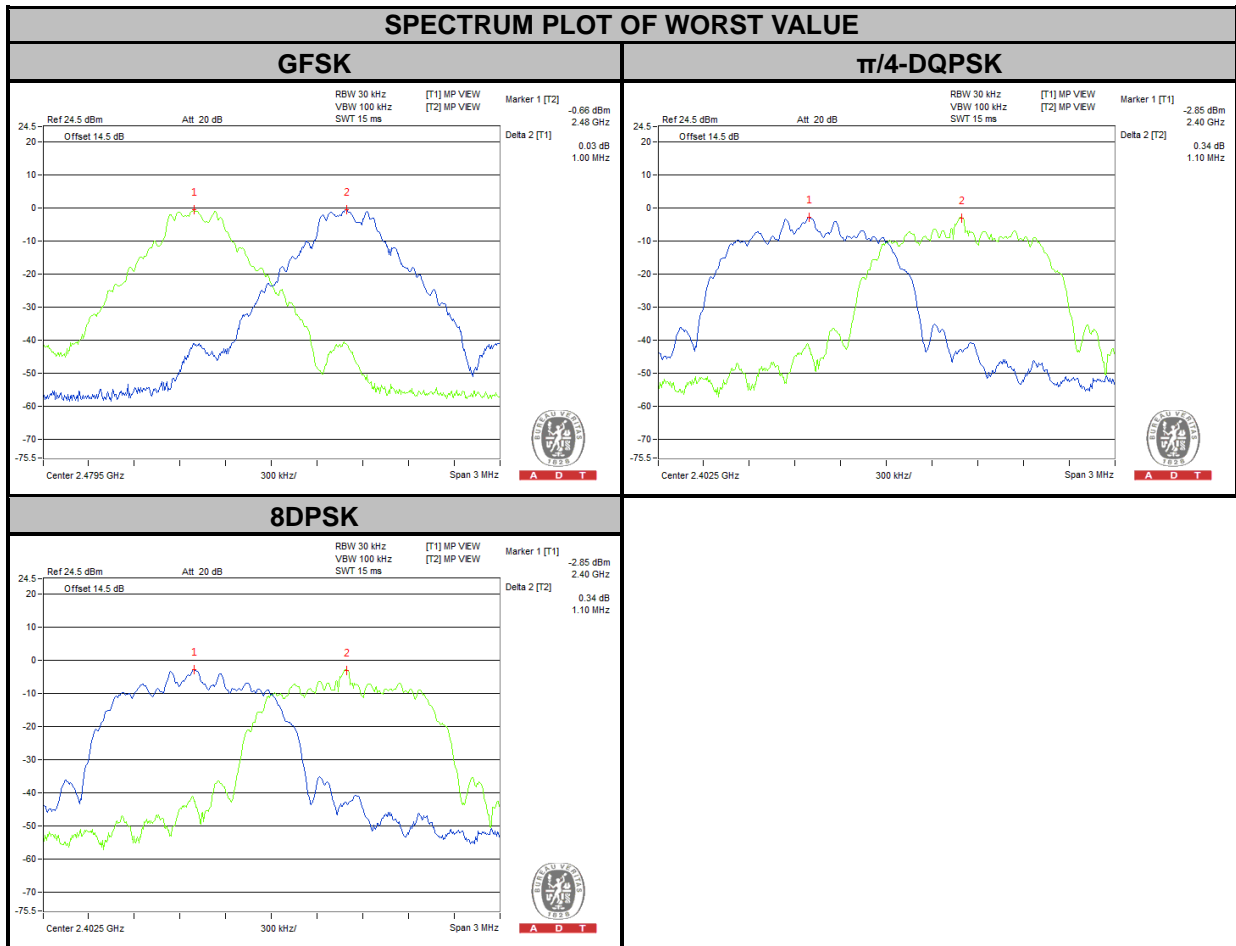

4.7 MAXIMUM OUTPUT POWER

4.7.1 LIMITS OF MAXIMUM OUTPUT POWER MEASUREMENT

The Maximum Output Power Measurement is 125mW.

4.7.2 TEST SETUP

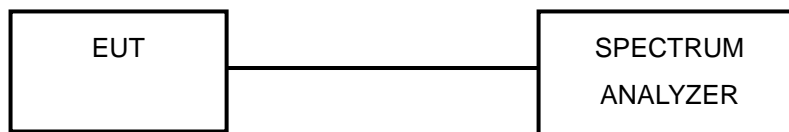

4.7.3 TEST INSTRUMENTS

Refer to section 4.1.2 to get information of above instrument.

4.7.4 TEST PROCEDURE

- Check the calibration of the measuring instrument using either an internal calibrator or a known signal from an external generator.
- Turn on the EUT and connect it to measurement instrument. Then set it to any one convenient frequency within its operating range. Set a reference level on the measuring instrument equal to the highest peak value.
- The center frequency of the spectrum analyzer is set to the fundamental frequency and using 3MHz RBW and 10 MHz VBW.
- Measure the captured power within the band and recording the plot.
- Repeat above procedures until all frequencies required were complete.

4.7.5 DEVIATION FROM TEST STANDARD

No deviation.

4.7.6 EUT OPERATING CONDITION

The software provided by client enabled the EUT to transmit and receive data at lowest, middle and highest channel frequencies individually.



A D T

4.7.7 TEST RESULTS

CHANNEL	FREQUENCY (MHz)	OUTPUT POWER (mW)			OUTPUT POWER (dBm)			POWER LIMIT (mW)	PASS / FAIL
		GFSK	$\pi/4$ -DQPSK	8DPSK	GFSK	$\pi/4$ -DQPSK	8DPSK		
0	2402	1.687	1.667	1.824	2.27	2.22	2.61	125	PASS
39	2441	1.750	1.683	1.901	2.43	2.26	2.79	125	PASS
78	2480	1.866	1.782	2.138	2.71	2.51	3.30	125	PASS

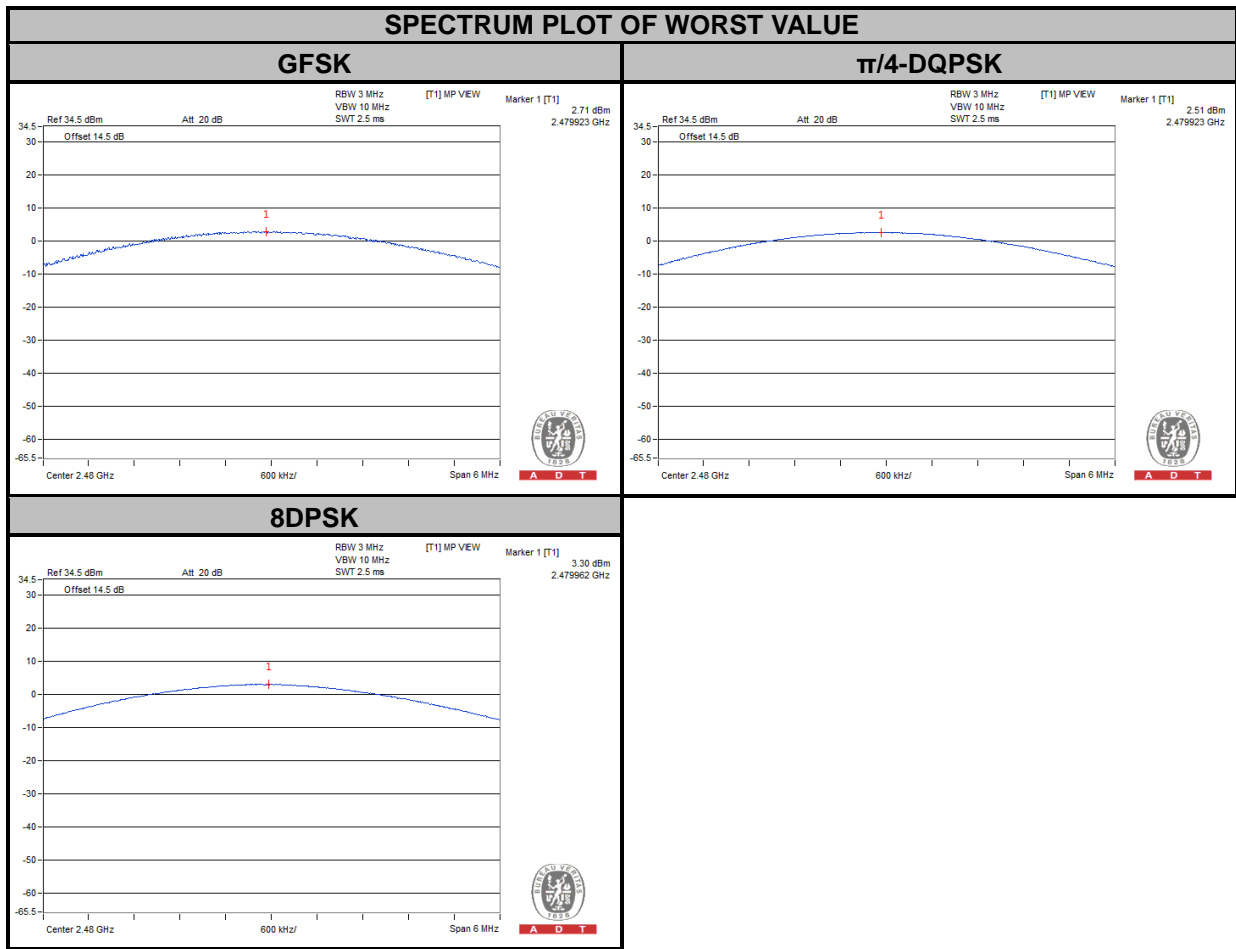

4.8 CONDUCTED OUT OF BAND EMISSION MEASUREMENT

4.8.1 LIMITS OF CONDUCTED OUT OF BAND EMISSION MEASUREMENT

Below -20dB of the highest emission level of operating band (in 100kHz RBW).

4.8.2 TEST INSTRUMENTS

Refer to section 4.1.2 to get information of above instrument.

4.8.3 TEST PROCEDURE

1. Set RBW = 100 kHz .
2. Set VBW = 300 kHz .
3. Set span to encompass the spectrum to be examined.
4. Detector = peak.
5. Trace Mode = max hold.
6. Sweep = auto couple.

4.8.4 DEVIATION FROM TEST STANDARD

No deviation.

4.8.5 EUT OPERATING CONDITION

The software provided by client enabled the EUT to transmit continuously.

4.8.6 TEST RESULTS

The spectrum plots are attached on the following images. D1 line indicates the highest level, D2 line indicates the 20dB offset below D1. It shows compliance with the requirement.



A D T

GFSK

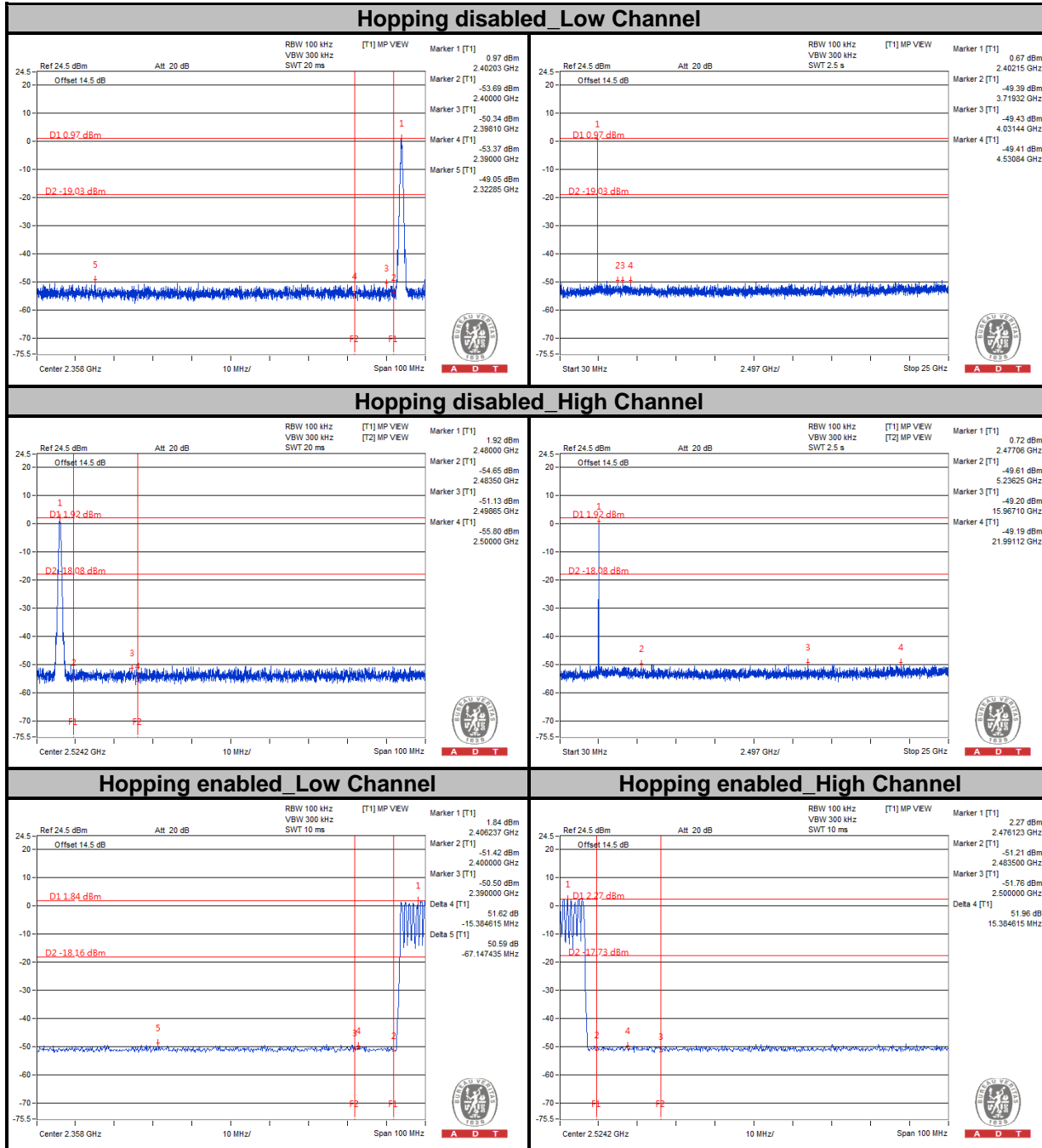



A D T

$\pi/4$ -DQPSK

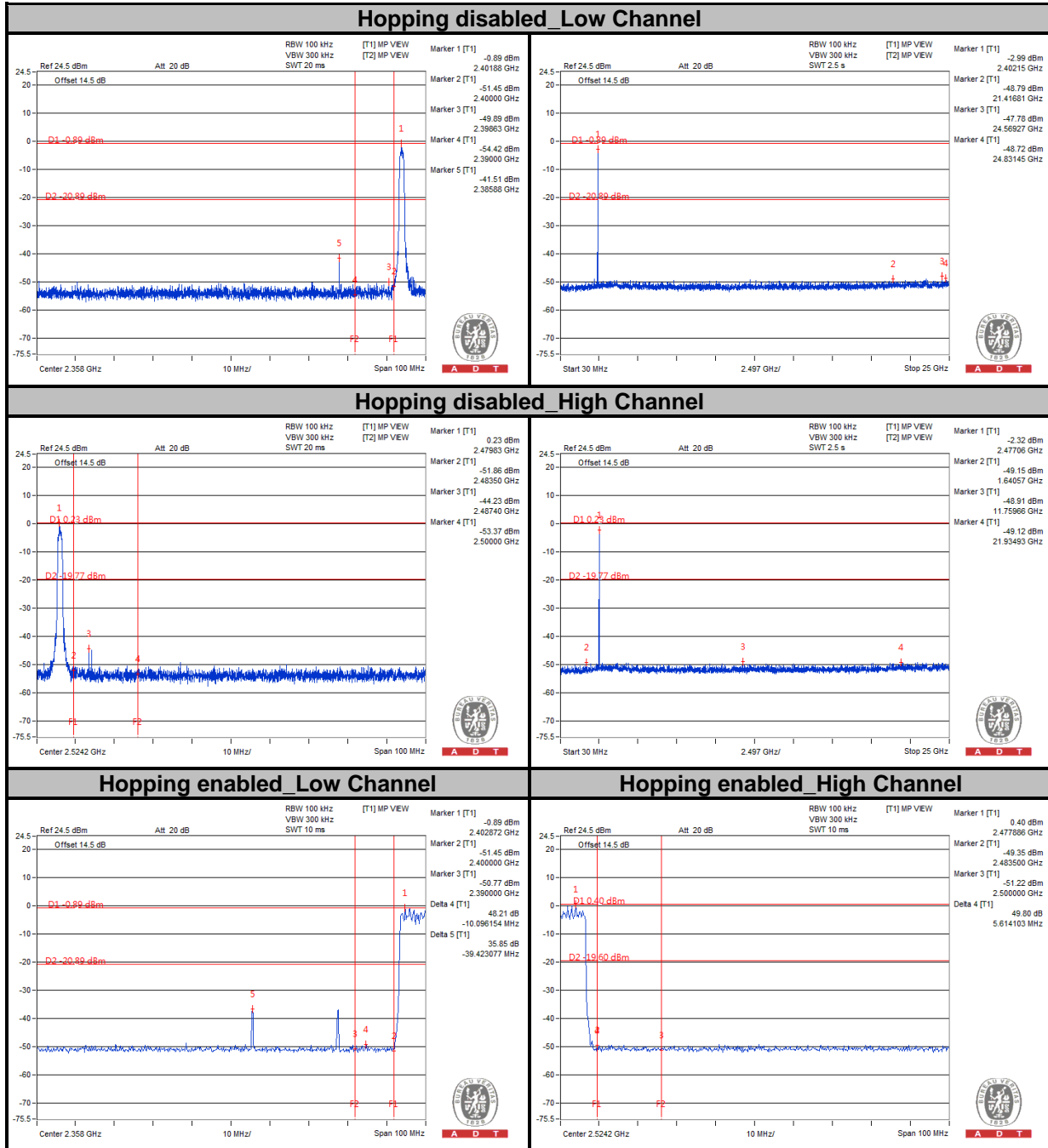



A D T

8DPSK

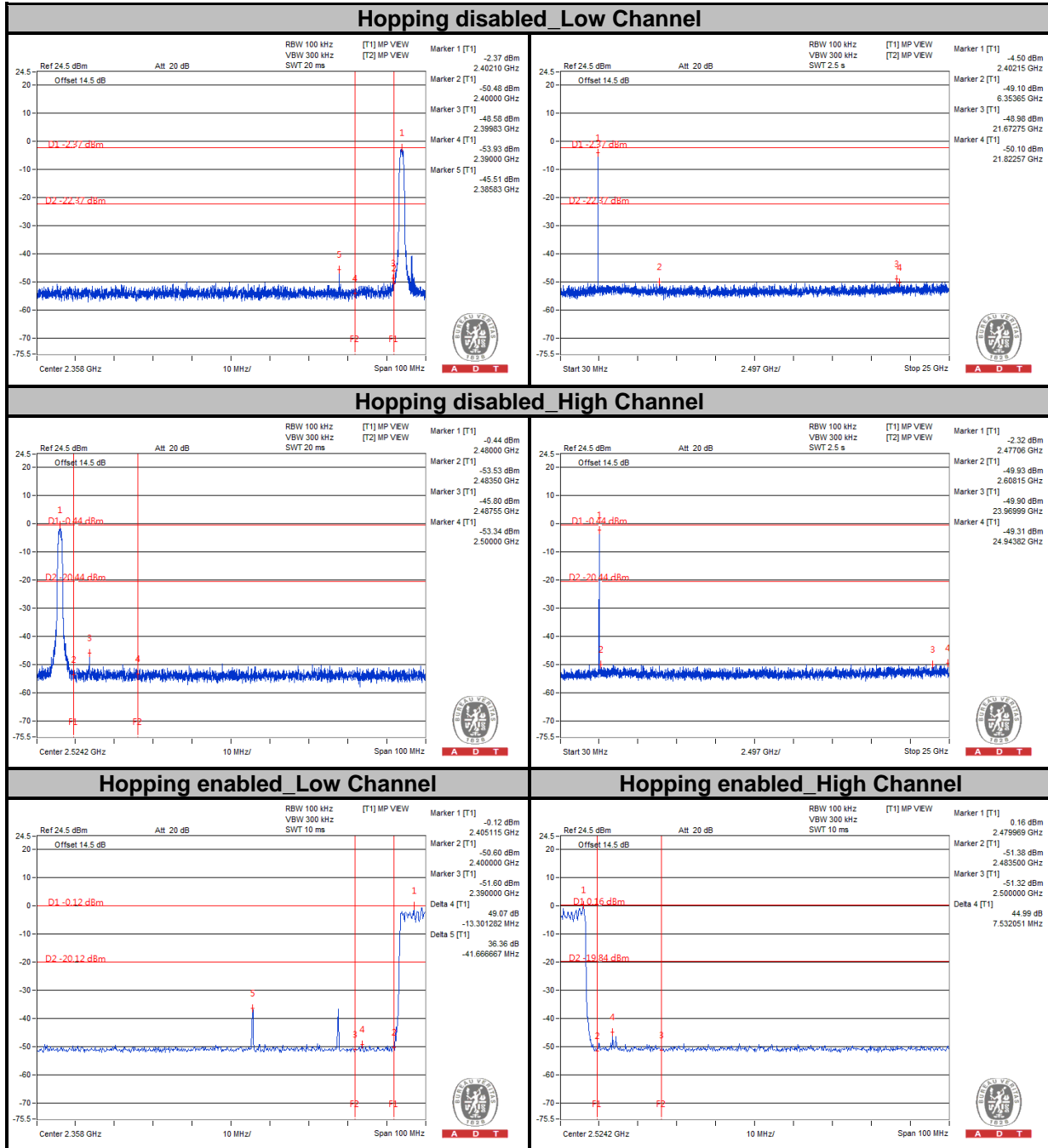



A D T

5. PHOTOGRAPHS OF THE TEST CONFIGURATION

Please refer to the attached file (Test Setup Photo).



6. INFORMATION ON THE TESTING LABORATORIES

We, Bureau Veritas Consumer Products Services (H.K.) Ltd., Taoyuan Branch, were founded in 1988 to provide our best service in EMC, Radio, Telecom and Safety consultation. Our laboratories are accredited and approved according to ISO/IEC 17025.

If you have any comments, please feel free to contact us at the following:

Linko EMC/RF Lab:

Tel: 886-2-26052180

Fax: 886-2-26051924

Hsin Chu EMC/RF/Telecom Lab:

Tel: 886-3-5935343

Fax: 886-3-5935342

Hwa Ya EMC/RF/Safety Lab:

Tel: 886-3-3183232

Fax: 886-3-3270892

Email: service.adt@tw.bureauveritas.com

Web Site: www.bureauveritas-adt.com

The address and road map of all our labs can be found in our web site also.



A D T

7. APPENDIX A – MODIFICATIONS RECORDERS FOR ENGINEERING CHANGES TO THE EUT BY THE LAB

No any modifications are made to the EUT by the lab during the test.

---END---