



# SUPPLEMENTARY FCC TEST REPORT (15.247)

**REPORT NO.:** RF120903C21S  
**MODEL NO.:** MC40N0  
**FCC ID:** UZ7MC40N0  
**RECEIVED:** Mar. 23, 2015  
**TESTED:** Apr. 09, 2015 ~ Apr. 16, 2015  
**ISSUED:** Jun. 05, 2015

**APPLICANT:** Zebra Technologies Corporation

**ADDRESS:** 1 Zebra Plaza, Holtsville, NY 11742

**ISSUED BY:** Bureau Veritas Consumer Products Services (H.K.)  
Ltd., Taoyuan Branch

**LAB ADDRESS:** No. 47-2, 14th Ling, Chia Pau Vil., Lin Kou Dist., New  
Taipei City, Taiwan ( R.O.C )

**TEST LOCATION:** No. 19, Hwa Ya 2nd Rd, Wen Hwa Vil., Kwei Shan  
Dist., Taoyuan City 33383, Taiwan (R.O.C.)

This report should not be used by the client to claim  
product certification, approval, or endorsement by  
TAF or any government agencies.



This report is for your exclusive use. Any copying or replication of this report to or for any other person or entity, or use of our name or trademark, is permitted only with our prior written permission. This report sets forth our findings solely with respect to the test samples identified herein. The results set forth in this report are not indicative or representative of the quality or characteristics of the lot from which a test sample was taken or any similar or identical product unless specifically and expressly noted. Our report includes all of the tests requested by you and the results thereof based upon the information that you provided to us. You have 60 days from date of issuance of this report to notify us of any material error or omission caused by our negligence, provided, however, that such notice shall be in writing and shall specifically address the issue you wish to raise. A failure to raise such issue within the prescribed time shall constitute your unqualified acceptance of the completeness of this report, the tests conducted and the correctness of the report contents. Unless specific mention, the uncertainty of measurement has been explicitly taken into account to declare the compliance or non-compliance to the specification.



# TABLE OF CONTENTS

REPORT ISSUE HISTORY RECORD .....	4
RELEASE CONTROL RECORD .....	5
1. CERTIFICATION.....	6
2. SUMMARY OF TEST RESULTS .....	7
2.1 MEASUREMENT UNCERTAINTY.....	7
3. GENERAL INFORMATION .....	8
3.1 GENERAL DESCRIPTION OF EUT .....	8
3.2 DESCRIPTION OF TEST MODES.....	10
3.2.1 TEST MODE APPLICABILITY AND TESTED CHANNEL DETAIL.....	11
3.3 DESCRIPTION OF SUPPORT UNITS.....	14
3.3.1 CONFIGURATION OF SYSTEM UNDER TEST .....	14
3.4 DUTY CYCLE TEST SIGNAL.....	15
3.5 GENERAL DESCRIPTION OF APPLIED STANDARDS.....	16
4. TEST TYPES AND RESULTS (FOR 2.4GHz BAND).....	17
4.1 RADIATED EMISSION AND BANDEDGE MEASUREMENT .....	17
4.1.1 LIMITS OF RADIATED EMISSION AND BANDEDGE MEASUREMENT .....	17
4.1.2 TEST INSTRUMENTS.....	18
4.1.3 TEST PROCEDURES .....	19
4.1.4 DEVIATION FROM TEST STANDARD .....	19
4.1.5 TEST SETUP .....	20
4.1.6 EUT OPERATING CONDITIONS .....	20
4.1.7 TEST RESULTS.....	21
4.2 CONDUCTED EMISSION MEASUREMENT .....	81
4.2.1 LIMITS OF CONDUCTED EMISSION MEASUREMENT .....	81
4.2.2 TEST INSTRUMENTS.....	81
4.2.3 TEST PROCEDURES .....	82
4.2.4 DEVIATION FROM TEST STANDARD .....	82
4.2.5 TEST SETUP .....	83
4.2.6 EUT OPERATING CONDITIONS .....	83
4.2.7 TEST RESULTS.....	84
4.3 6dB BANDWIDTH MEASUREMENT .....	88
4.3.1 LIMITS OF 6dB BANDWIDTH MEASUREMENT .....	88
4.3.2 TEST SETUP .....	88
4.3.3 TEST INSTRUMENTS.....	88
4.3.4 TEST PROCEDURE.....	88
4.3.5 DEVIATION FROM TEST STANDARD .....	88
4.3.6 EUT OPERATING CONDITIONS .....	88
4.3.7 TEST RESULTS.....	89
4.4 CONDUCTED OUTPUT POWER .....	93
4.4.1 LIMITS OF CONDUCTED OUTPUT POWER MEASUREMENT.....	93
4.4.2 TEST SETUP .....	93
4.4.3 TEST INSTRUMENTS.....	93
4.4.4 TEST PROCEDURES .....	93
4.4.5 DEVIATION FROM TEST STANDARD .....	93
4.4.6 EUT OPERATING CONDITIONS .....	93
4.4.7 TEST RESULTS.....	94
4.5 POWER SPECTRAL DENSITY MEASUREMENT.....	106
4.5.1 LIMITS OF POWER SPECTRAL DENSITY MEASUREMENT .....	106
4.5.2 TEST SETUP .....	106
4.5.3 TEST INSTRUMENTS.....	106
4.5.4 TEST PROCEDURE .....	106



A D T

4.5.5	DEVIATION FROM TEST STANDARD .....	106
4.5.6	EUT OPERATING CONDITION.....	106
4.5.7	TEST RESULTS.....	107
4.6	CONDUCTED OUT OF BAND EMISSION MEASUREMENT .....	111
4.6.1	LIMITS OF CONDUCTED OUT OF BAND EMISSION MEASUREMENT .....	111
4.6.2	TEST SETUP .....	111
4.6.3	TEST INSTRUMENTS .....	111
4.6.4	TEST PROCEDURE .....	111
4.6.5	DEVIATION FROM TEST STANDARD .....	111
4.6.6	EUT OPERATING CONDITION.....	111
4.6.7	TEST RESULTS.....	112
5.	PHOTOGRAPHS OF THE TEST CONFIGURATION.....	124
6.	INFORMATION ON THE TESTING LABORATORIES .....	125
7.	APPENDIX A – MODIFICATIONS RECORDERS FOR ENGINEERING CHANGES TO THE EUT BY THE LAB .....	126



A D T

## REPORT ISSUE HISTORY RECORD

ISSUE NO.	REASON FOR CHANGE	DATE ISSUED
1	Original release	Sep. 17, 2012
2	1. New LCM, TP, Scanner engine, larger speaker and MIC 2. New antenna design (WLAN1, WLAN2) and new antenna location (WLAN2, BT) 3. New Schematic, Block Diagram 4. Update SW and HW	Jun. 05, 2015



A D T

## RELEASE CONTROL RECORD

ISSUE NO.	REASON FOR CHANGE	DATE ISSUED
RF120903C21S	Original release	Jun. 05, 2015

## 1. CERTIFICATION

**PRODUCT:** Mobile Computer  
**MODEL NO.:** MC40N0  
**BRAND:** Symbol  
**APPLICANT:** Zebra Technologies Corporation  
**TESTED:** Apr. 09, 2015 ~ Apr. 16, 2015  
**TEST SAMPLE:** Engineering Sample  
**STANDARDS:** **FCC Part 15, Subpart C (Section 15.247)**  
ANSI C63.10-2013

The above equipment (model: MC40N0) has been tested by **Bureau Veritas Consumer Products Services (H.K.) Ltd., Taoyuan Branch**, and found compliance with the requirement of the above standards. The test record, data evaluation & Equipment Under Test (EUT) configurations represented herein are true and accurate accounts of the measurements of the sample's EMC characteristics under the conditions specified in this report.

**PREPARED BY** : Rona Chen , **DATE** : Jun. 05, 2015  
Rona Chen / Specialist

**APPROVED BY** : Sam chen , **DATE** : Jun. 05, 2015  
Sam Chen / Senior Project Engineer

## 2. SUMMARY OF TEST RESULTS

The EUT has been tested according to the following specifications:

APPLIED STANDARD: FCC PART 15, SUBPART C (SECTION 15.247)			
STANDARD SECTION	TEST TYPE	RESULT	REMARK
15.207	AC Power Conducted Emission	PASS	Meet the requirement of limit. Minimum passing margin is -8.26dB at 0.37304MHz.
15.205 & 15.209	Radiated Emissions	PASS	Meet the requirement of limit. Minimum passing margin is -1.01dB at 2484MHz.
15.247(d)	Band Edge Measurement	PASS	Meet the requirement of limit.
15.247(d)	Antenna Port Emission	PASS	Meet the requirement of limit.
15.247(a)(2)	6dB bandwidth	PASS	Meet the requirement of limit.
15.247(b)	Conducted power	PASS	Meet the requirement of limit.
15.247(e)	Power Spectral Density	PASS	Meet the requirement of limit.
15.203	Antenna Requirement	PASS	No antenna connector is used.

### 2.1 MEASUREMENT UNCERTAINTY

Where relevant, the following measurement uncertainty levels have been estimated for tests performed on the EUT as specified in CISPR 16-4-2:

MEASUREMENT	FREQUENCY	UNCERTAINTY
Conducted emissions	9kHz~30MHz	2.44 dB
Radiated emissions	30MHz ~ 200MHz	2.93 dB
	200MHz ~1000MHz	2.95 dB
	1GHz ~ 18GHz	2.26 dB
	18GHz ~ 40GHz	1.94 dB

This uncertainty represents an expanded uncertainty expressed at approximately the 95% confidence level using a coverage factor of  $k = 2$ .



### 3. GENERAL INFORMATION

#### 3.1 GENERAL DESCRIPTION OF EUT

<b>EUT</b>	Mobile Computer
<b>MODEL NO.</b>	MC40N0
<b>POWER SUPPLY</b>	5Vdc (adapter or host equipment) 3.7Vdc (Li-ion battery)
<b>MODULATION TYPE</b>	CCK, DQPSK, DBPSK for DSSS 64QAM, 16QAM, QPSK, BPSK for OFDM
<b>MODULATION TECHNOLOGY</b>	DSSS, OFDM
<b>TRANSFER RATE</b>	802.11b: 11.0 / 5.5 / 2.0 / 1.0 Mbps 802.11g: 54.0 / 48.0 / 36.0 / 24.0 / 18.0 / 12.0 / 9.0 / 6.0 Mbps 802.11n: up to MCS7
<b>OPERATING FREQUENCY</b>	2412 ~ 2472MHz
<b>NUMBER OF CHANNEL</b>	13 for 802.11b, 802.11g, 802.11n (20MHz)
<b>OUTPUT POWER</b>	225.42mW
<b>ANTENNA TYPE</b>	Refer to Note as below
<b>ANTENNA CONNECTOR</b>	NA
<b>DATA CABLE</b>	Refer to Note as below
<b>I/O PORTS</b>	Refer to user's manual
<b>ACCESSORY DEVICES</b>	Refer to Note as below
<b>HW VERSION</b>	EV2
<b>SW VERSION</b>	Android version: 4.4.4 Build number: 99-4AJ22-K-0008-0004-V0-M1-031315

**NOTE:**

1. This report is issued as a supplementary report of BV ADT report no.: RF120903C21. For more detail of difference compared with original report, please refer to issued no. 7 of "report issue history record" on page 4. Therefore, all items had been performed and presented in the test report.
2. The device is available with or without MSR.
3. Antenna gain is listed as table below.

Configuration	Antenna type	Main antenna gain (dBi)	AUX antenna gain (dBi)
With MSR	PIFA	2.6	0.8
Without MSR		2.7	1.0





A D T

4. The following accessories are optional.

ITEM	BRAND	MODEL	SPECIFICATION
Adapter	Motorola / Symbol	IU08-2050120-WP	I/P: 100-240Vac, 50/60Hz, 0.2A O/P: 5Vdc, 1.2A
Earphone 1	Symbol / Zebra	NA	1.3m non-shielded cable w/o core
Earphone 2	Symbol / Zebra	21-UNIV-HDSET1-01R	1.2m non-shielded cable w/o core
Micro USB Cable	Symbol / Zebra	25-MCXUSB-01R	1.5m shielded cable w/o core
Holster	Symbol / Zebra	SG-MC40HLSTR-03R	--
Handstrap	Symbol / Zebra	SG-MC40Strap-10R	--

5. The EUT uses following battery.

<b>Brand</b>	Symbol / Zebra
<b>Rating</b>	3.7Vdc

6. The EUT incorporates a MIMO function. Physically, the EUT provides 1 completed transmitter and 2 receivers.

MODULATION MODE	TX FUNCTION
<b>802.11b</b>	1TX
<b>802.11g</b>	1TX
<b>802.11n (20MHz)</b>	1TX

7. The above EUT information is declared by the manufacturer and for more detailed features description, please refer to the manufacturer's specifications or User's Manual.



A D T

### 3.2 DESCRIPTION OF TEST MODES

#### FOR 2.4GHz:

13 hannels are provided for 802.11b, 802.11g and 802.11n (20MHz):

CHANNEL	FREQUENCY	CHANNEL	FREQUENCY
1	2412MHz	8	2447MHz
2	2417MHz	9	2452MHz
3	2422MHz	10	2457MHz
4	2427MHz	11	2462MHz
5	2432MHz	12	2467MHz
6	2437MHz	13	2472MHz
7	2442MHz		



A D T

**3.2.1 TEST MODE APPLICABILITY AND TESTED CHANNEL DETAIL**

**WLAN 2.4GHz:**

EUT CONFIGURE MODE	APPLICABLE TO				DESCRIPTION
	RE≥1G	RE<1G	PLC	APCM	
A	√	√	√	√	With MSR SKU
B	√	√	√	√	Without MSR SKU

Where **RE≥1G**: Radiated Emission above 1GHz      **RE<1G**: Radiated Emission below 1GHz  
**PLC**: Power Line Conducted Emission      **APCM**: Antenna Port Conducted Measurement

**NOTE:** The EUT had been pre-tested on the positioned of each 3 axis. The worst case was found when positioned on **Y-plane**.

**RADIATED EMISSION TEST (ABOVE 1GHz):**

- Pre-Scan has been conducted to determine the worst-case mode from all possible combinations between available modulations, data rates and antenna ports (if EUT with antenna diversity architecture).
- Following channel(s) was (were) selected for the final test as listed below.

EUT CONFIGURE MODE	MODE	AVAILABLE CHANNEL	TESTED CHANNEL	MODULATION TECHNOLOGY	MODULATION TYPE	DATA RATE (Mbps)
A, B	802.11b	1 to 13	1, 6, 11, 12, 13	DSSS	DBPSK	1.0
A, B	802.11g	1 to 13	1, 6, 11, 12, 13	OFDM	BPSK	6.0
A, B	802.11n (20MHz)	1 to 13	1, 6, 11, 12, 13	OFDM	BPSK	MCS0

**RADIATED EMISSION TEST (BELOW 1GHz):**

- Pre-Scan has been conducted to determine the worst-case mode from all possible combinations between available modulations, data rates and antenna ports (if EUT with antenna diversity architecture).
- Following channel(s) was (were) selected for the final test as listed below.

EUT CONFIGURE MODE	MODE	AVAILABLE CHANNEL	TESTED CHANNEL	MODULATION TECHNOLOGY	MODULATION TYPE	DATA RATE (Mbps)
A, B	802.11b	1 to 13	1, 6, 11, 12, 13	DSSS	DBPSK	1.0
A, B	802.11g	1 to 13	1, 6, 11, 12, 13	OFDM	BPSK	6.0
A, B	802.11n (20MHz)	1 to 13	1, 6, 11, 12, 13	OFDM	BPSK	MCS0



A D T

**POWER LINE CONDUCTED EMISSION TEST:**

- Pre-Scan has been conducted to determine the worst-case mode from all possible combinations between available modulations, data rates and antenna ports (if EUT with antenna diversity architecture).
- Following channel(s) was (were) selected for the final test as listed below.

EUT CONFIGURE MODE	MODE	AVAILABLE CHANNEL	TESTED CHANNEL	MODULATION TECHNOLOGY	MODULATION TYPE	DATA RATE (Mbps)
A	802.11n (20MHz)	1 to 13	11	OFDM	BPSK	MCS0
B	802.11g	1 to 13	1	OFDM	BPSK	6.0

**BANDEDGE MEASUREMENT:**

- Pre-Scan has been conducted to determine the worst-case mode from all possible combinations between available modulations, data rates and antenna ports (if EUT with antenna diversity architecture).
- Following channel(s) was (were) selected for the final test as listed below.

EUT CONFIGURE MODE	MODE	AVAILABLE CHANNEL	TESTED CHANNEL	MODULATION TECHNOLOGY	MODULATION TYPE	DATA RATE (Mbps)
A, B	802.11b	1 to 13	1, 6, 11	DSSS	DBPSK	1.0
A, B	802.11g	1 to 13	1, 6, 11	OFDM	BPSK	6.0
A, B	802.11n (20MHz)	1 to 13	1, 6, 11	OFDM	BPSK	MCS0

**ANTENNA PORT CONDUCTED MEASUREMENT:**

- This item includes all test value of each mode, but only includes spectrum plot of worst value of each mode.
- Pre-Scan has been conducted to determine the worst-case mode from all possible combinations between available modulations, data rates and antenna ports (if EUT with antenna diversity architecture).
- Following channel(s) was (were) selected for the final test as listed below.

EUT CONFIGURE MODE	MODE	AVAILABLE CHANNEL	TESTED CHANNEL	MODULATION TECHNOLOGY	MODULATION TYPE	DATA RATE (Mbps)
A, B	802.11b	1 to 13	1, 6, 11	DSSS	DBPSK	1.0
A, B	802.11g	1 to 13	1, 6, 11	OFDM	BPSK	6.0
A, B	802.11n (20MHz)	1 to 13	1, 6, 11	OFDM	BPSK	MCS0



A D T

**TEST CONDITION:**

APPLICABLE TO	ENVIRONMENTAL CONDITIONS	INPUT POWER	TESTED BY
RE $\geq$ 1G	25deg. C, 65%RH	120Vac, 60Hz	Gavin Wu / Toby Tian
RE<1G	25deg. C, 65%RH	120Vac, 60Hz	Gavin Wu
PLC	25deg. C, 65%RH	120Vac, 60Hz	Toby Tian
APCM	25deg. C, 65%RH	120Vac, 60Hz	Howard Kao

### 3.3 DESCRIPTION OF SUPPORT UNITS

The EUT has been tested as an independent unit together with other necessary accessories or support units.

#### 3.3.1 CONFIGURATION OF SYSTEM UNDER TEST

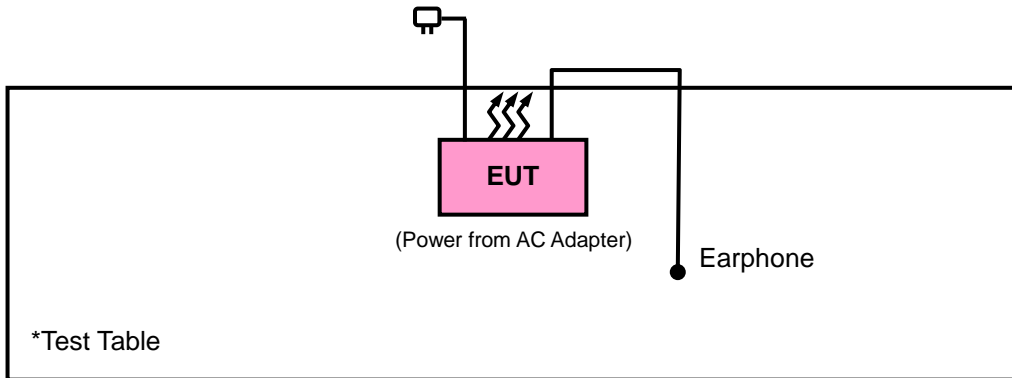

### 3.4 DUTY CYCLE TEST SIGNAL

#### Mode B

#### WLAN 2.4GHz

**802.11b:** Duty cycle of test signal is 100 %, duty factor is not required.

**802.11g:** Duty cycle of test signal is > 98 %, duty factor is not required.

**802.11n (20MHz):** Duty cycle of test signal is > 98 %, duty factor is not required.

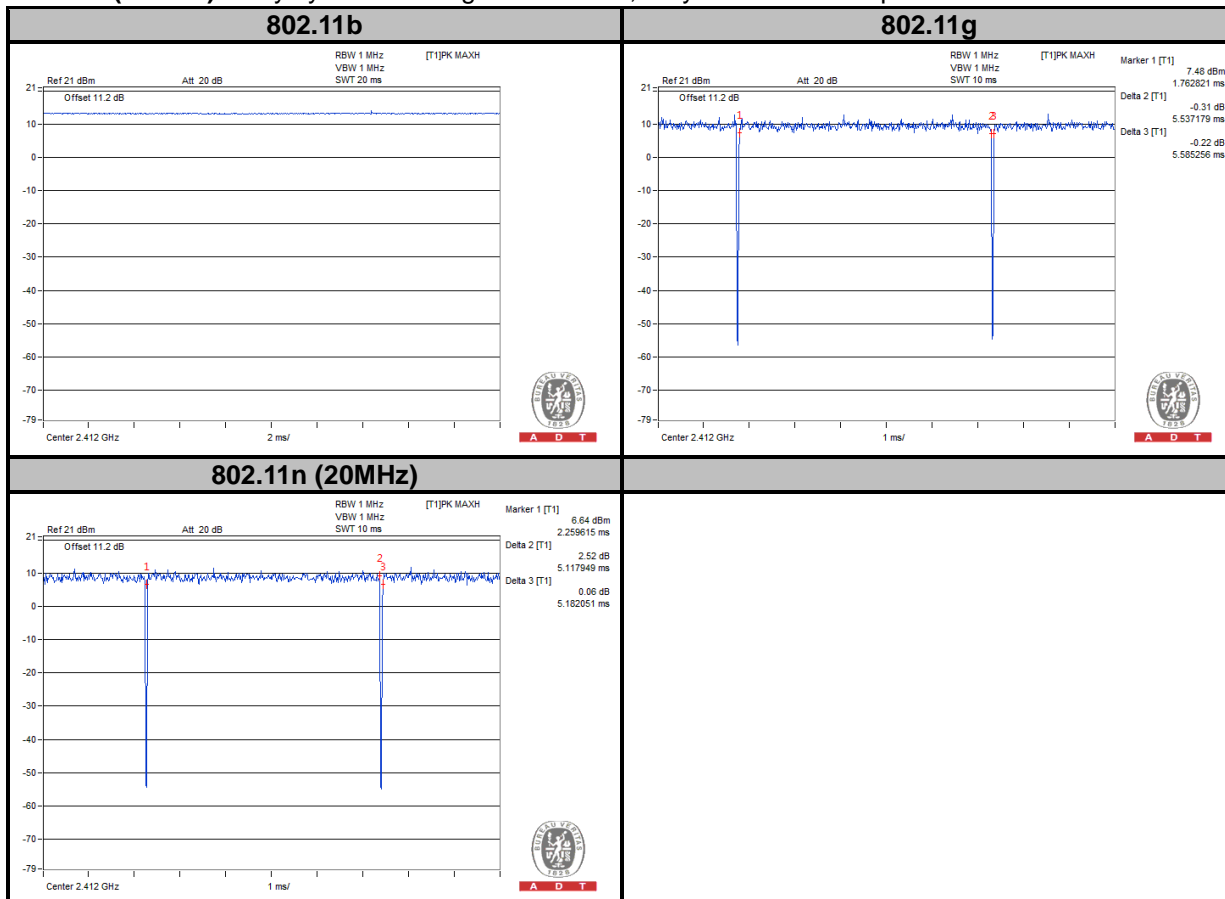



### 3.5 GENERAL DESCRIPTION OF APPLIED STANDARDS

The EUT is a RF Product. According to the specifications of the manufacturer, it must comply with the requirements of the following standards:

**FCC Part 15, Subpart C (15.247)**  
**558074 D01 DTS Meas Guidance v03r02**  
ANSI C63.10-2013

All test items have been performed and recorded as per the above standards.

**NOTE:** The EUT has been verified to comply with the requirements of FCC Part 15, Subpart B, Class B (DoC). The test report has been issued separately.



## 4. TEST TYPES AND RESULTS (FOR 2.4GHz BAND)

### 4.1 RADIATED EMISSION AND BANDEDGE MEASUREMENT

#### 4.1.1 LIMITS OF RADIATED EMISSION AND BANDEDGE MEASUREMENT

Radiated emissions which fall in the restricted bands must comply with the radiated emission limits specified as below table. Other emissions shall be at least 20dB below the highest level of the desired power:

FREQUENCIES (MHz)	FIELD STRENGTH (microvolts/meter)	MEASUREMENT DISTANCE (meters)
0.009 ~ 0.490	2400/F(kHz)	300
0.490 ~ 1.705	24000/F(kHz)	30
1.705 ~ 30.0	30	30
30 ~ 88	100	3
88 ~ 216	150	3
216 ~ 960	200	3
Above 960	500	3

**NOTE:**

1. The lower limit shall apply at the transition frequencies.
2. Emission level (dBuV/m) = 20 log Emission level (uV/m).
3. For frequencies above 1000MHz, the field strength limits are based on average detector, however, the peak field strength of any emission shall not exceed the maximum permitted average limits, specified above by more than 20dB under any condition of modulation.



A D T

**4.1.2 TEST INSTRUMENTS**

DESCRIPTION & MANUFACTURER	MODEL NO.	SERIAL NO.	DATE OF CALIBRATION	DUE DATE OF CALIBRATION
Test Receiver Agilent	N9038A	MY51210203	Jan.21, 2015	Jan.21, 2016
Spectrum Analyzer Agilent	N9010A	MY52220314	Sep.03, 2014	Sep.02, 2015
Spectrum Analyzer ROHDE & SCHWARZ	FSU43	101261	Dec. 10, 2014	Dec. 09, 2015
BILOG Antenna SCHWARZBECK	VULB9168	9168-472	Feb. 04, 2015	Feb. 04, 2016
HORN Antenna SCHWARZBECK	BBHA 9120 D	9120D-969	Feb. 09, 2015	Feb. 09, 2016
HORN Antenna SCHWARZBECK	BBHA 9170	9170-480	Feb. 04, 2015	Feb. 04, 2016
Loop Antenna	EM-6879	269	Aug.13, 2014	Aug.12, 2015
Preamplifier Agilent	8449B	3008A01911	Aug. 09, 2014	Aug. 08, 2015
Preamplifier EMCI	EMC 012645	980115	Dec. 12, 2014	Dec. 11, 2015
Preamplifier EMCI	EMC 184045	980116	Jan. 09, 2015	Jan. 08, 2016
Preamplifier EMCI	EMC 330H	980112	Dec. 27, 2014	Dec. 26, 2015
RF signal cable HUBER+SUHNNER	SUCOFLEX 104	309219/4 2950114	Oct. 18, 2014	Oct. 17, 2015
RF signal cable HUBER+SUHNNER	SUCOFLEX 104	250130/4	Oct. 18, 2014	Oct. 17, 2015
RF signal cable Worken	RG-213	NA	Nov. 07, 2014	Nov. 06, 2015
Software BV ADT	E3 6.120103	NA	NA	NA
Antenna Tower MF	MFA-440H	NA	NA	NA
Turn Table MF	MFT-201SS	NA	NA	NA
Antenna Tower & Turn Table Controller MF	MF-7802	NA	NA	NA
Power Meter	ML2495A	1232002	Sep. 17, 2014	Sep. 16, 2015
Power Sensor	MA2411B	1207325	Sep. 17, 2014	Sep. 16, 2015

- NOTE:**
1. The calibration interval of the above test instruments is 12 months and the calibrations are traceable to NML/ROC and NIST/USA.
  2. The calibration interval of the loop antenna is 24 months and the calibrations are traceable to NML/ROC and NIST/USA.
  3. The test was performed in HwaYa Chamber 10.
  4. The horn antenna and HP preamplifier (model: 8449B) are used only for the measurement of emission frequency above 1GHz if tested.
  5. The FCC Site Registration No. is 690701.
  6. The IC Site Registration No. is IC 7450F-10.

#### 4.1.3 TEST PROCEDURES

- a. The EUT was placed on the top of a rotating table 0.8 meters (for below 1GHz) / 1.5 meters (for above 1GHz) above the ground at 3 meter chamber room for test. The table was rotated 360 degrees to determine the position of the highest radiation.
- b. The EUT was set 3 meters away from the interference-receiving antenna, which was mounted on the top of a variable-height antenna tower.
- c. Height of receiving antenna is varied from one meter to four meters above the ground to determine the maximum value of the field strength. Both horizontal and vertical polarizations of the antenna are set to make the measurement.
- d. For each suspected emission, the EUT was arranged to its worst case and then the antenna was tuned to heights from 1 meter to 4 meters and the rotatable table was turned from 0 degrees to 360 degrees to find the maximum reading.
- e. The test-receiver system was set to Peak Detect Function and Specified Bandwidth with Maximum Hold Mode.
- f. If the emission level of the EUT in peak mode was lower than the limit specified, then testing could be stopped and the peak values of the EUT would be reported. Otherwise the emissions would be re-tested one by one using peak, quasi-peak or average method as specified and then reported in a data sheet.

**NOTE:**

1. The resolution bandwidth and video bandwidth of test receiver/spectrum analyzer is 120kHz for Quasi-peak detection at frequency below 1GHz.
2. The resolution bandwidth of test receiver/spectrum analyzer is 1MHz and video bandwidth is 3MHz for Peak detection at frequency above 1GHz.
3. The resolution bandwidth of test receiver/spectrum analyzer is 1MHz and the video bandwidth is 1kHz (Duty cycle < 98%) or 10Hz (Duty cycle > 98%) for Average detection (AV) at frequency above 1GHz.
4. All modes of operation were investigated and the worst-case emissions are reported.

#### 4.1.4 DEVIATION FROM TEST STANDARD

No deviation.

#### 4.1.5 TEST SETUP

<Frequency Range 30MHz ~ 1GHz>

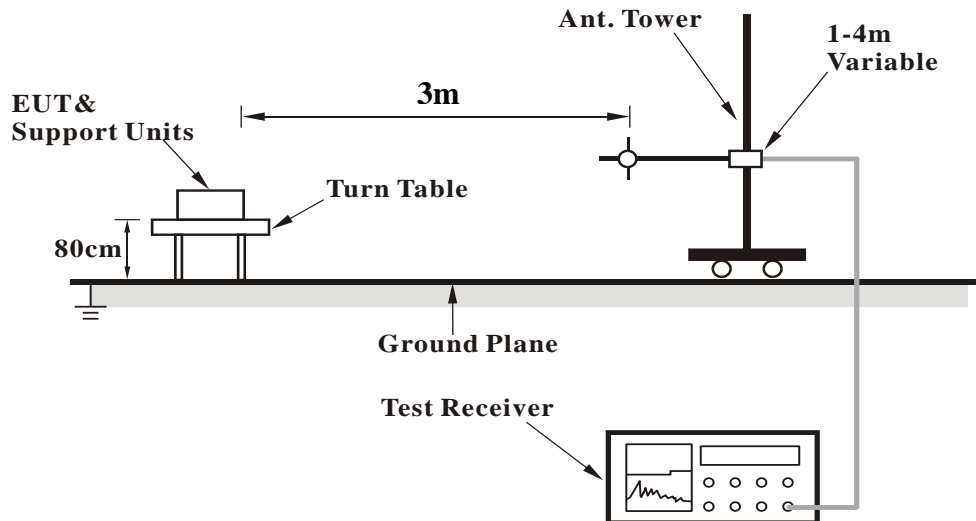

<Frequency Range above 1GHz>

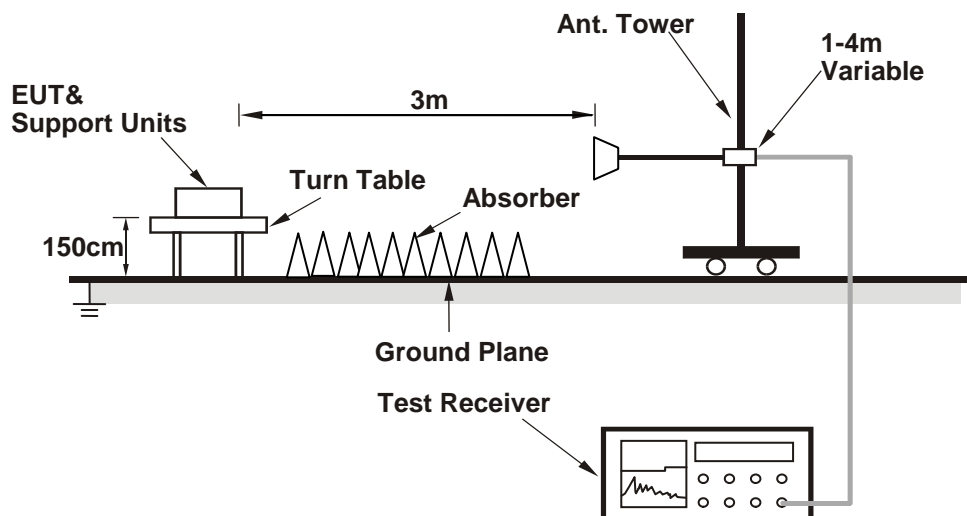

For the actual test configuration, please refer to the attached file (Test Setup Photo).

#### 4.1.6 EUT OPERATING CONDITIONS

- Placed the EUT on a testing table.
- Use the software to control the EUT under transmission condition continuously at specific channel frequency.



A D T

**4.1.7 TEST RESULTS**

**ABOVE 1GHz WORST-CASE DATA**

**Mode A**

**802.11b**

EUT TEST CONDITION		MEASUREMENT DETAIL	
CHANNEL	Channel 1	FREQUENCY RANGE	1GHz ~ 25GHz
INPUT POWER	120Vac, 60 Hz	DETECTOR FUNCTION	Peak (PK) Average (AV)
ENVIRONMENTAL CONDITIONS	25deg. C, 65%RH	TESTED BY	Gavin Wu

**ANTENNA POLARITY & TEST DISTANCE: HORIZONTAL AT 3 M**

FREQ. (MHz)	EMISSION LEVEL (dBuV/m)	READ LEVEL (dBuV)	LIMIT (dBuV/m)	MARGIN (dB)	ANTENNA FACTOR (dB/m)	CABLE LOSS (dB)	PREAMP FACTOR (dB)	ANTENNA HEIGHT (cm)	TABLE ANGLE (Degree)	REMARK
2390	52.12	59.19	54	-1.88	26.91	3.54	37.52	132	243	Average
2390	60.9	67.97	74	-13.1	26.91	3.54	37.52	132	243	Peak
2412	106.08	113.1			26.96	3.54	37.52	132	243	Average
2412	110.23	117.25			26.96	3.54	37.52	132	243	Peak
2500	37.49	43.92	54	-16.51	27.2	3.62	37.25	132	243	Average
2500	56.47	62.9	74	-17.53	27.2	3.62	37.25	132	243	Peak
4824	43.86	60.18	54	-10.14	30.99	5.77	53.08	124	233	Average
4824	46.62	62.94	74	-27.38	30.99	5.77	53.08	124	233	Peak

**ANTENNA POLARITY & TEST DISTANCE: VERTICAL AT 3 M**

FREQ. (MHz)	EMISSION LEVEL (dBuV/m)	READ LEVEL (dBuV)	LIMIT (dBuV/m)	MARGIN (dB)	ANTENNA FACTOR (dB/m)	CABLE LOSS (dB)	PREAMP FACTOR (dB)	ANTENNA HEIGHT (cm)	TABLE ANGLE (Degree)	REMARK
2390	46.8	53.87	54	-7.2	26.91	3.54	37.52	117	214	Average
2390	58.5	65.57	74	-15.5	26.91	3.54	37.52	117	214	Peak
2412	99.71	106.73			26.96	3.54	37.52	117	214	Average
2412	103.97	110.99			26.96	3.54	37.52	117	214	Peak
2498	34.17	40.6	54	-19.83	27.2	3.62	37.25	117	214	Average
2498	55.84	62.27	74	-18.16	27.2	3.62	37.25	117	214	Peak
4824	37.68	54	54	-16.32	30.99	5.77	53.08	140	264	Average
4824	43.58	59.9	74	-30.42	30.99	5.77	53.08	140	264	Peak

**REMARKS:**

- Emission Level = Read Level + Antenna Factor + Cable Loss - Preamp Factor  
Margin value = Emission level – Limit value
- 2412MHz: Fundamental frequency.



A D T

EUT TEST CONDITION		MEASUREMENT DETAIL	
CHANNEL	Channel 6	FREQUENCY RANGE	1GHz ~ 25GHz
INPUT POWER	120Vac, 60 Hz	DETECTOR FUNCTION	Peak (PK) Average (AV)
ENVIRONMENTAL CONDITIONS	25deg. C, 65%RH	TESTED BY	Gavin Wu

ANTENNA POLARITY & TEST DISTANCE: HORIZONTAL AT 3 M										
FREQ. (MHz)	EMISSION LEVEL (dBuV/m)	READ LEVEL (dBuV)	LIMIT (dBuV/m)	MARGIN (dB)	ANTENNA FACTOR (dB/m)	CABLE LOSS (dB)	PREAMP FACTOR (dB)	ANTENNA HEIGHT (cm)	TABLE ANGLE (Degree)	REMARK
2360	41.38	48.56	54	-12.62	26.81	3.5	37.49	134	241	Average
2360	56.64	63.82	74	-17.36	26.81	3.5	37.49	134	241	Peak
2437	106.28	113.12			27.06	3.56	37.46	134	241	Average
2437	110.63	117.47			27.06	3.56	37.46	134	241	Peak
2488	46.72	53.22	54	-7.28	27.2	3.62	37.32	134	241	Average
2488	57.61	64.11	74	-16.39	27.2	3.62	37.32	134	241	Peak
4874	43.92	60.11	54	-10.08	31.06	5.8	53.05	151	229	Average
4874	46.11	62.3	74	-27.89	31.06	5.8	53.05	151	229	Peak
ANTENNA POLARITY & TEST DISTANCE: VERTICAL AT 3 M										
FREQ. (MHz)	EMISSION LEVEL (dBuV/m)	READ LEVEL (dBuV)	LIMIT (dBuV/m)	MARGIN (dB)	ANTENNA FACTOR (dB/m)	CABLE LOSS (dB)	PREAMP FACTOR (dB)	ANTENNA HEIGHT (cm)	TABLE ANGLE (Degree)	REMARK
2324	35.17	42.44	54	-18.83	26.72	3.48	37.47	119	209	Average
2324	56.27	63.54	74	-17.73	26.72	3.48	37.47	119	209	Peak
2437	100.7	107.54			27.06	3.56	37.46	119	209	Average
2437	104.76	111.6			27.06	3.56	37.46	119	209	Peak
2488	38.87	45.37	54	-15.13	27.2	3.62	37.32	119	209	Average
2488	55.34	61.84	74	-18.66	27.2	3.62	37.32	119	209	Peak
4874	41.06	57.25	54	-12.94	31.06	5.8	53.05	102	194	Average
4874	44.04	60.23	74	-29.96	31.06	5.8	53.05	102	194	Peak

**REMARKS:**

- Emission Level = Read Level + Antenna Factor + Cable Loss - Preamp Factor  
Margin value = Emission level – Limit value
- 2437MHz: Fundamental frequency.



A D T

EUT TEST CONDITION		MEASUREMENT DETAIL	
CHANNEL	Channel 11	FREQUENCY RANGE	1GHz ~ 25GHz
INPUT POWER	120Vac, 60 Hz	DETECTOR FUNCTION	Peak (PK) Average (AV)
ENVIRONMENTAL CONDITIONS	25deg. C, 65%RH	TESTED BY	Gavin Wu

**ANTENNA POLARITY & TEST DISTANCE: HORIZONTAL AT 3 M**

FREQ. (MHz)	EMISSION LEVEL (dBuV/m)	READ LEVEL (dBuV)	LIMIT (dBuV/m)	MARGIN (dB)	ANTENNA FACTOR (dB/m)	CABLE LOSS (dB)	PREAMP FACTOR (dB)	ANTENNA HEIGHT (cm)	TABLE ANGLE (Degree)	REMARK
2358	34.5	41.68	54	-19.5	26.81	3.5	37.49	105	221	Average
2358	55.22	62.4	74	-18.78	26.81	3.5	37.49	105	221	Peak
2462	107.02	113.73			27.1	3.58	37.39	105	221	Average
2462	111.17	117.88			27.1	3.58	37.39	105	221	Peak
2486	52.39	58.96	54	-1.61	27.15	3.6	37.32	105	221	Average
2486	62.2	68.77	74	-11.8	27.15	3.6	37.32	105	221	Peak
4924	42.34	58.42	54	-11.66	31.12	5.83	53.03	124	192	Average
4924	45.41	61.49	74	-28.59	31.12	5.83	53.03	124	192	Peak

**ANTENNA POLARITY & TEST DISTANCE: VERTICAL AT 3 M**

FREQ. (MHz)	EMISSION LEVEL (dBuV/m)	READ LEVEL (dBuV)	LIMIT (dBuV/m)	MARGIN (dB)	ANTENNA FACTOR (dB/m)	CABLE LOSS (dB)	PREAMP FACTOR (dB)	ANTENNA HEIGHT (cm)	TABLE ANGLE (Degree)	REMARK
2346	32.51	39.73	54	-21.49	26.77	3.5	37.49	139	215	Average
2346	56.13	63.35	74	-17.87	26.77	3.5	37.49	139	215	Peak
2462	100.05	106.76			27.1	3.58	37.39	139	215	Average
2462	104.43	111.14			27.1	3.58	37.39	139	215	Peak
2492	41.87	48.3	54	-12.13	27.2	3.62	37.25	139	215	Average
2492	56.74	63.17	74	-17.26	27.2	3.62	37.25	139	215	Peak
4924	40.26	56.34	54	-13.74	31.12	5.83	53.03	138	199	Average
4924	42.13	58.21	74	-31.87	31.12	5.83	53.03	138	199	Peak

**REMARKS:**

- Emission Level = Read Level + Antenna Factor + Cable Loss - Preamp Factor  
Margin value = Emission level – Limit value
- 2462MHz: Fundamental frequency.



A D T

EUT TEST CONDITION		MEASUREMENT DETAIL	
CHANNEL	Channel 12	FREQUENCY RANGE	1GHz ~ 25GHz
INPUT POWER	120Vac, 60 Hz	DETECTOR FUNCTION	Peak (PK) Average (AV)
ENVIRONMENTAL CONDITIONS	25deg. C, 65%RH	TESTED BY	Gavin Wu

ANTENNA POLARITY & TEST DISTANCE: HORIZONTAL AT 3 M										
FREQ. (MHz)	EMISSION LEVEL (dBuV/m)	READ LEVEL (dBuV)	LIMIT (dBuV/m)	MARGIN (dB)	ANTENNA FACTOR (dB/m)	CABLE LOSS (dB)	PREAMP FACTOR (dB)	ANTENNA HEIGHT (cm)	TABLE ANGLE (Degree)	REMARK
2362	32.69	39.87	54	-21.31	26.81	3.5	37.49	104	224	Average
2362	56.67	63.85	74	-17.33	26.81	3.5	37.49	104	224	Peak
2467	79.52	86.14			27.1	3.6	37.32	104	224	Average
2467	84.87	91.49			27.1	3.6	37.32	104	224	Peak
2490	35.14	41.64	54	-18.86	27.2	3.62	37.32	104	224	Average
2490	56.69	63.19	74	-17.31	27.2	3.62	37.32	104	224	Peak
ANTENNA POLARITY & TEST DISTANCE: VERTICAL AT 3 M										
FREQ. (MHz)	EMISSION LEVEL (dBuV/m)	READ LEVEL (dBuV)	LIMIT (dBuV/m)	MARGIN (dB)	ANTENNA FACTOR (dB/m)	CABLE LOSS (dB)	PREAMP FACTOR (dB)	ANTENNA HEIGHT (cm)	TABLE ANGLE (Degree)	REMARK
2378	33.54	40.66	54	-20.46	26.86	3.52	37.5	115	191	Average
2378	57.16	64.28	74	-16.84	26.86	3.52	37.5	115	191	Peak
2467	74.05	80.67			27.1	3.6	37.32	115	191	Average
2467	79.17	85.79			27.1	3.6	37.32	115	191	Peak
2490	34.59	41.09	54	-19.41	27.2	3.62	37.32	115	191	Average
2490	56.88	63.38	74	-17.12	27.2	3.62	37.32	115	191	Peak

**REMARKS:**

- Emission Level = Read Level + Antenna Factor + Cable Loss - Preamp Factor  
Margin value = Emission level – Limit value
- 2467MHz: Fundamental frequency.





A D T

EUT TEST CONDITION		MEASUREMENT DETAIL	
CHANNEL	Channel 13	FREQUENCY RANGE	1GHz ~ 25GHz
INPUT POWER	120Vac, 60 Hz	DETECTOR FUNCTION	Peak (PK) Average (AV)
ENVIRONMENTAL CONDITIONS	25deg. C, 65%RH	TESTED BY	Gavin Wu

ANTENNA POLARITY & TEST DISTANCE: HORIZONTAL AT 3 M										
FREQ. (MHz)	EMISSION LEVEL (dBuV/m)	READ LEVEL (dBuV)	LIMIT (dBuV/m)	MARGIN (dB)	ANTENNA FACTOR (dB/m)	CABLE LOSS (dB)	PREAMP FACTOR (dB)	ANTENNA HEIGHT (cm)	TABLE ANGLE (Degree)	REMARK
2322	33.34	40.61	54	-20.66	26.72	3.48	37.47	103	224	Average
2322	56.95	64.22	74	-17.05	26.72	3.48	37.47	103	224	Peak
2472	79.57	86.14			27.15	3.6	37.32	103	224	Average
2472	84.47	91.04			27.15	3.6	37.32	103	224	Peak
2486	36.12	42.69	54	-17.88	27.15	3.6	37.32	103	224	Average
2486	56.5	63.07	74	-17.5	27.15	3.6	37.32	103	224	Peak
ANTENNA POLARITY & TEST DISTANCE: VERTICAL AT 3 M										
FREQ. (MHz)	EMISSION LEVEL (dBuV/m)	READ LEVEL (dBuV)	LIMIT (dBuV/m)	MARGIN (dB)	ANTENNA FACTOR (dB/m)	CABLE LOSS (dB)	PREAMP FACTOR (dB)	ANTENNA HEIGHT (cm)	TABLE ANGLE (Degree)	REMARK
2390	32.72	39.79	54	-21.28	26.91	3.54	37.52	114	204	Average
2390	56.97	64.04	74	-17.03	26.91	3.54	37.52	114	204	Peak
2472	73.77	80.34			27.15	3.6	37.32	114	204	Average
2472	79.19	85.76			27.15	3.6	37.32	114	204	Peak
2496	33.93	40.36	54	-20.07	27.2	3.62	37.25	114	204	Average
2496	57.33	63.76	74	-16.67	27.2	3.62	37.25	114	204	Peak

**REMARKS:**

- Emission Level = Read Level + Antenna Factor + Cable Loss - Preamp Factor  
Margin value = Emission level – Limit value
- 2472MHz: Fundamental frequency.



A D T

802.11g

EUT TEST CONDITION		MEASUREMENT DETAIL	
CHANNEL	Channel 1	FREQUENCY RANGE	1GHz ~ 25GHz
INPUT POWER	120Vac, 60 Hz	DETECTOR FUNCTION	Peak (PK) Average (AV)
ENVIRONMENTAL CONDITIONS	25deg. C, 65%RH	TESTED BY	Gavin Wu

**ANTENNA POLARITY & TEST DISTANCE: HORIZONTAL AT 3 M**

FREQ. (MHz)	EMISSION LEVEL (dBuV/m)	READ LEVEL (dBuV)	LIMIT (dBuV/m)	MARGIN (dB)	ANTENNA FACTOR (dB/m)	CABLE LOSS (dB)	PREAMP FACTOR (dB)	ANTENNA HEIGHT (cm)	TABLE ANGLE (Degree)	REMARK
2390	52.71	59.78	54	-1.29	26.91	3.54	37.52	134	240	Average
2390	72.62	79.69	74	-1.38	26.91	3.54	37.52	134	240	Peak
2412	99.85	106.87			26.96	3.54	37.52	134	240	Average
2412	109.7	116.72			26.96	3.54	37.52	134	240	Peak
2490	36.62	43.12	54	-17.38	27.2	3.62	37.32	134	240	Average
2490	55.95	62.45	74	-18.05	27.2	3.62	37.32	134	240	Peak
4824	30.25	46.57	54	-23.75	30.99	5.77	53.08	125	235	Average
4824	41.26	57.58	74	-32.74	30.99	5.77	53.08	125	235	Peak

**ANTENNA POLARITY & TEST DISTANCE: VERTICAL AT 3 M**

FREQ. (MHz)	EMISSION LEVEL (dBuV/m)	READ LEVEL (dBuV)	LIMIT (dBuV/m)	MARGIN (dB)	ANTENNA FACTOR (dB/m)	CABLE LOSS (dB)	PREAMP FACTOR (dB)	ANTENNA HEIGHT (cm)	TABLE ANGLE (Degree)	REMARK
2390	47.47	54.54	54	-6.53	26.91	3.54	37.52	121	205	Average
2390	64.79	71.86	74	-9.21	26.91	3.54	37.52	121	205	Peak
2412	93.33	100.35			26.96	3.54	37.52	121	205	Average
2412	102.99	110.01			26.96	3.54	37.52	121	205	Peak
2488	34.2	40.7	54	-19.8	27.2	3.62	37.32	121	205	Average
2488	55.98	62.48	74	-18.02	27.2	3.62	37.32	121	205	Peak
4824	28.51	44.83	54	-25.49	30.99	5.77	53.08	113	298	Average
4824	37.5	53.82	74	-36.5	30.99	5.77	53.08	113	298	Peak

**REMARKS:**

- Emission Level = Read Level + Antenna Factor + Cable Loss - Preamp Factor  
Margin value = Emission level – Limit value
- 2412MHz: Fundamental frequency.



A D T

EUT TEST CONDITION		MEASUREMENT DETAIL	
CHANNEL	Channel 6	FREQUENCY RANGE	1GHz ~ 25GHz
INPUT POWER	120Vac, 60 Hz	DETECTOR FUNCTION	Peak (PK) Average (AV)
ENVIRONMENTAL CONDITIONS	25deg. C, 65%RH	TESTED BY	Gavin Wu

**ANTENNA POLARITY & TEST DISTANCE: HORIZONTAL AT 3 M**

FREQ. (MHz)	EMISSION LEVEL (dBuV/m)	READ LEVEL (dBuV)	LIMIT (dBuV/m)	MARGIN (dB)	ANTENNA FACTOR (dB/m)	CABLE LOSS (dB)	PREAMP FACTOR (dB)	ANTENNA HEIGHT (cm)	TABLE ANGLE (Degree)	REMARK
2390	48.54	55.61	54	-5.46	26.91	3.54	37.52	133	243	Average
2390	64.46	71.53	74	-9.54	26.91	3.54	37.52	133	243	Peak
2437	102.72	109.56			27.06	3.56	37.46	133	243	Average
2437	112.6	119.44			27.06	3.56	37.46	133	243	Peak
2484	49.1	55.67	54	-4.9	27.15	3.6	37.32	133	243	Average
2484	63.41	69.98	74	-10.59	27.15	3.6	37.32	133	243	Peak
4874	31.73	47.92	54	-22.27	31.06	5.8	53.05	100	193	Average
4874	41.09	57.28	74	-32.91	31.06	5.8	53.05	100	193	Peak

**ANTENNA POLARITY & TEST DISTANCE: VERTICAL AT 3 M**

FREQ. (MHz)	EMISSION LEVEL (dBuV/m)	READ LEVEL (dBuV)	LIMIT (dBuV/m)	MARGIN (dB)	ANTENNA FACTOR (dB/m)	CABLE LOSS (dB)	PREAMP FACTOR (dB)	ANTENNA HEIGHT (cm)	TABLE ANGLE (Degree)	REMARK
2388	44.57	51.62	54	-9.43	26.91	3.54	37.5	148	212	Average
2388	61.73	68.78	74	-12.27	26.91	3.54	37.5	148	212	Peak
2437	96.2	103.04			27.06	3.56	37.46	148	212	Average
2437	106.16	113			27.06	3.56	37.46	148	212	Peak
2486	40.3	46.87	54	-13.7	27.15	3.6	37.32	148	212	Average
2486	57.86	64.43	74	-16.14	27.15	3.6	37.32	148	212	Peak
4874	30.29	46.48	54	-23.71	31.06	5.8	53.05	105	197	Average
4874	40.58	56.77	74	-33.42	31.06	5.8	53.05	105	197	Peak

**REMARKS:**

- Emission Level = Read Level + Antenna Factor + Cable Loss - Preamp Factor  
Margin value = Emission level – Limit value
- 2437MHz: Fundamental frequency.



A D T

EUT TEST CONDITION		MEASUREMENT DETAIL	
CHANNEL	Channel 11	FREQUENCY RANGE	1GHz ~ 25GHz
INPUT POWER	120Vac, 60 Hz	DETECTOR FUNCTION	Peak (PK) Average (AV)
ENVIRONMENTAL CONDITIONS	25deg. C, 65%RH	TESTED BY	Gavin Wu

**ANTENNA POLARITY & TEST DISTANCE: HORIZONTAL AT 3 M**

FREQ. (MHz)	EMISSION LEVEL (dBuV/m)	READ LEVEL (dBuV)	LIMIT (dBuV/m)	MARGIN (dB)	ANTENNA FACTOR (dB/m)	CABLE LOSS (dB)	PREAMP FACTOR (dB)	ANTENNA HEIGHT (cm)	TABLE ANGLE (Degree)	REMARK
2380	33.98	41.1	54	-20.02	26.86	3.52	37.5	132	228	Average
2380	55.48	62.6	74	-18.52	26.86	3.52	37.5	132	228	Peak
2462	99.87	106.58			27.1	3.58	37.39	132	228	Average
2462	109.49	116.2			27.1	3.58	37.39	132	228	Peak
2484	52.53	59.1	54	-1.47	27.15	3.6	37.32	132	228	Average
2484	72.35	78.92	74	-1.65	27.15	3.6	37.32	132	228	Peak
4924	28.98	45.06	54	-25.02	31.12	5.83	53.03	123	229	Average
4924	39.71	55.79	74	-34.29	31.12	5.83	53.03	123	229	Peak

**ANTENNA POLARITY & TEST DISTANCE: VERTICAL AT 3 M**

FREQ. (MHz)	EMISSION LEVEL (dBuV/m)	READ LEVEL (dBuV)	LIMIT (dBuV/m)	MARGIN (dB)	ANTENNA FACTOR (dB/m)	CABLE LOSS (dB)	PREAMP FACTOR (dB)	ANTENNA HEIGHT (cm)	TABLE ANGLE (Degree)	REMARK
2386	33.15	40.22	54	-20.85	26.91	3.52	37.5	100	338	Average
2386	55.67	62.74	74	-18.33	26.91	3.52	37.5	100	338	Peak
2462	91.54	98.25			27.1	3.58	37.39	100	338	Average
2462	101.78	108.49			27.1	3.58	37.39	100	338	Peak
2484	42.95	49.52	54	-11.05	27.15	3.6	37.32	100	338	Average
2484	64.91	71.48	74	-9.09	27.15	3.6	37.32	100	338	Peak
4924	28.32	44.4	54	-25.68	31.12	5.83	53.03	109	281	Average
4924	40.39	56.47	74	-33.61	31.12	5.83	53.03	109	281	Peak

**REMARKS:**

- Emission Level = Read Level + Antenna Factor + Cable Loss - Preamp Factor  
Margin value = Emission level – Limit value
- 2462MHz: Fundamental frequency.



A D T

EUT TEST CONDITION		MEASUREMENT DETAIL	
CHANNEL	Channel 12	FREQUENCY RANGE	1GHz ~ 25GHz
INPUT POWER	120Vac, 60 Hz	DETECTOR FUNCTION	Peak (PK) Average (AV)
ENVIRONMENTAL CONDITIONS	25deg. C, 65%RH	TESTED BY	Gavin Wu

ANTENNA POLARITY & TEST DISTANCE: HORIZONTAL AT 3 M										
FREQ. (MHz)	EMISSION LEVEL (dBuV/m)	READ LEVEL (dBuV)	LIMIT (dBuV/m)	MARGIN (dB)	ANTENNA FACTOR (dB/m)	CABLE LOSS (dB)	PREAMP FACTOR (dB)	ANTENNA HEIGHT (cm)	TABLE ANGLE (Degree)	REMARK
2366	33.61	40.78	54	-20.39	26.81	3.52	37.5	105	226	Average
2366	56.89	64.06	74	-17.11	26.81	3.52	37.5	105	226	Peak
2467	80.68	87.3			27.1	3.6	37.32	105	226	Average
2467	91.61	98.23			27.1	3.6	37.32	105	226	Peak
2484	36.68	43.25	54	-17.32	27.15	3.6	37.32	105	226	Average
2484	58.85	65.42	74	-15.15	27.15	3.6	37.32	105	226	Peak
ANTENNA POLARITY & TEST DISTANCE: VERTICAL AT 3 M										
FREQ. (MHz)	EMISSION LEVEL (dBuV/m)	READ LEVEL (dBuV)	LIMIT (dBuV/m)	MARGIN (dB)	ANTENNA FACTOR (dB/m)	CABLE LOSS (dB)	PREAMP FACTOR (dB)	ANTENNA HEIGHT (cm)	TABLE ANGLE (Degree)	REMARK
2374	33.57	40.69	54	-20.43	26.86	3.52	37.5	118	179	Average
2374	56.28	63.4	74	-17.72	26.86	3.52	37.5	118	179	Peak
2467	74.02	80.64			27.1	3.6	37.32	118	179	Average
2467	84.21	90.83			27.1	3.6	37.32	118	179	Peak
2494	34.86	41.29	54	-19.14	27.2	3.62	37.25	118	179	Average
2494	56.87	63.3	74	-17.13	27.2	3.62	37.25	118	179	Peak

**REMARKS:**

- Emission Level = Read Level + Antenna Factor + Cable Loss - Preamp Factor  
Margin value = Emission level – Limit value
- 2467MHz: Fundamental frequency.



A D T

EUT TEST CONDITION		MEASUREMENT DETAIL	
CHANNEL	Channel 13	FREQUENCY RANGE	1GHz ~ 25GHz
INPUT POWER	120Vac, 60 Hz	DETECTOR FUNCTION	Peak (PK) Average (AV)
ENVIRONMENTAL CONDITIONS	25deg. C, 65%RH	TESTED BY	Gavin Wu

ANTENNA POLARITY & TEST DISTANCE: HORIZONTAL AT 3 M										
FREQ. (MHz)	EMISSION LEVEL (dBuV/m)	READ LEVEL (dBuV)	LIMIT (dBuV/m)	MARGIN (dB)	ANTENNA FACTOR (dB/m)	CABLE LOSS (dB)	PREAMP FACTOR (dB)	ANTENNA HEIGHT (cm)	TABLE ANGLE (Degree)	REMARK
2348	33.4	40.62	54	-20.6	26.77	3.5	37.49	102	221	Average
2348	56.22	63.44	74	-17.78	26.77	3.5	37.49	102	221	Peak
2472	78.91	85.48			27.15	3.6	37.32	102	221	Average
2472	89.02	95.59			27.15	3.6	37.32	102	221	Peak
2484	40.12	46.69	54	-13.88	27.15	3.6	37.32	102	221	Average
2484	68.4	74.97	74	-5.6	27.15	3.6	37.32	102	221	Peak
ANTENNA POLARITY & TEST DISTANCE: VERTICAL AT 3 M										
FREQ. (MHz)	EMISSION LEVEL (dBuV/m)	READ LEVEL (dBuV)	LIMIT (dBuV/m)	MARGIN (dB)	ANTENNA FACTOR (dB/m)	CABLE LOSS (dB)	PREAMP FACTOR (dB)	ANTENNA HEIGHT (cm)	TABLE ANGLE (Degree)	REMARK
2384	33.52	40.64	54	-20.48	26.86	3.52	37.5	116	186	Average
2384	56.74	63.86	74	-17.26	26.86	3.52	37.5	116	186	Peak
2472	73.18	79.75			27.15	3.6	37.32	116	186	Average
2472	82.75	89.32			27.15	3.6	37.32	116	186	Peak
2484	37.37	43.94	54	-16.63	27.15	3.6	37.32	116	186	Average
2484	64.21	70.78	74	-9.79	27.15	3.6	37.32	116	186	Peak

**REMARKS:**

- Emission Level = Read Level + Antenna Factor + Cable Loss - Preamp Factor  
Margin value = Emission level – Limit value
- 2472MHz: Fundamental frequency.



A D T

**802.11n (20MHz)**

EUT TEST CONDITION		MEASUREMENT DETAIL	
CHANNEL	Channel 1	FREQUENCY RANGE	1GHz ~ 25GHz
INPUT POWER	120Vac, 60 Hz	DETECTOR FUNCTION	Peak (PK) Average (AV)
ENVIRONMENTAL CONDITIONS	25deg. C, 65%RH	TESTED BY	Gavin Wu

**ANTENNA POLARITY & TEST DISTANCE: HORIZONTAL AT 3 M**

FREQ. (MHz)	EMISSION LEVEL (dBuV/m)	READ LEVEL (dBuV)	LIMIT (dBuV/m)	MARGIN (dB)	ANTENNA FACTOR (dB/m)	CABLE LOSS (dB)	PREAMP FACTOR (dB)	ANTENNA HEIGHT (cm)	TABLE ANGLE (Degree)	REMARK
2390	52.08	59.15	54	-1.92	26.91	3.54	37.52	132	242	Average
2390	71.99	79.06	74	-2.01	26.91	3.54	37.52	132	242	Peak
2412	98.93	105.95			26.96	3.54	37.52	132	242	Average
2412	108.48	115.5			26.96	3.54	37.52	132	242	Peak
2494	37.03	43.46	54	-16.97	27.2	3.62	37.25	132	242	Average
2494	55.64	62.07	74	-18.36	27.2	3.62	37.25	132	242	Peak
4824	29.7	46.02	54	-24.3	30.99	5.77	53.08	126	233	Average
4824	41.1	57.42	74	-32.9	30.99	5.77	53.08	126	233	Peak

**ANTENNA POLARITY & TEST DISTANCE: VERTICAL AT 3 M**

FREQ. (MHz)	EMISSION LEVEL (dBuV/m)	READ LEVEL (dBuV)	LIMIT (dBuV/m)	MARGIN (dB)	ANTENNA FACTOR (dB/m)	CABLE LOSS (dB)	PREAMP FACTOR (dB)	ANTENNA HEIGHT (cm)	TABLE ANGLE (Degree)	REMARK
2390	46.49	53.56	54	-7.51	26.91	3.54	37.52	149	212	Average
2390	67.53	74.6	74	-6.47	26.91	3.54	37.52	149	212	Peak
2412	92.91	99.93			26.96	3.54	37.52	149	212	Average
2412	102.53	109.55			26.96	3.54	37.52	149	212	Peak
2500	34.16	40.59	54	-19.84	27.2	3.62	37.25	149	212	Average
2500	55.38	61.81	74	-18.62	27.2	3.62	37.25	149	212	Peak
4824	28.65	44.97	54	-25.35	30.99	5.77	53.08	105	240	Average
4824	39.67	55.99	74	-34.33	30.99	5.77	53.08	105	240	Peak

**REMARKS:**

- Emission Level = Read Level + Antenna Factor + Cable Loss - Preamp Factor  
Margin value = Emission level – Limit value
- 2412MHz: Fundamental frequency.



A D T

EUT TEST CONDITION		MEASUREMENT DETAIL	
CHANNEL	Channel 6	FREQUENCY RANGE	1GHz ~ 25GHz
INPUT POWER	120Vac, 60 Hz	DETECTOR FUNCTION	Peak (PK) Average (AV)
ENVIRONMENTAL CONDITIONS	25deg. C, 65%RH	TESTED BY	Gavin Wu

**ANTENNA POLARITY & TEST DISTANCE: HORIZONTAL AT 3 M**

FREQ. (MHz)	EMISSION LEVEL (dBuV/m)	READ LEVEL (dBuV)	LIMIT (dBuV/m)	MARGIN (dB)	ANTENNA FACTOR (dB/m)	CABLE LOSS (dB)	PREAMP FACTOR (dB)	ANTENNA HEIGHT (cm)	TABLE ANGLE (Degree)	REMARK
2390	50.97	58.04	54	-3.03	26.91	3.54	37.52	133	241	Average
2390	67.16	74.23	74	-6.84	26.91	3.54	37.52	133	241	Peak
2437	103.04	109.88			27.06	3.56	37.46	133	241	Average
2437	112.6	119.44			27.06	3.56	37.46	133	241	Peak
2484	50	56.57	54	-4	27.15	3.6	37.32	133	241	Average
2484	66.41	72.98	74	-7.59	27.15	3.6	37.32	133	241	Peak
4874	31.07	47.26	54	-22.93	31.06	5.8	53.05	144	194	Average
4874	40.8	56.99	74	-33.2	31.06	5.8	53.05	144	194	Peak

**ANTENNA POLARITY & TEST DISTANCE: VERTICAL AT 3 M**

FREQ. (MHz)	EMISSION LEVEL (dBuV/m)	READ LEVEL (dBuV)	LIMIT (dBuV/m)	MARGIN (dB)	ANTENNA FACTOR (dB/m)	CABLE LOSS (dB)	PREAMP FACTOR (dB)	ANTENNA HEIGHT (cm)	TABLE ANGLE (Degree)	REMARK
2390	45.18	52.25	54	-8.82	26.91	3.54	37.52	148	214	Average
2390	60.4	67.47	74	-13.6	26.91	3.54	37.52	148	214	Peak
2437	96.49	103.33			27.06	3.56	37.46	148	214	Average
2437	106.03	112.87			27.06	3.56	37.46	148	214	Peak
2488	40.52	47.02	54	-13.48	27.2	3.62	37.32	148	214	Average
2488	56.29	62.79	74	-17.71	27.2	3.62	37.32	148	214	Peak
4874	30.83	47.02	54	-23.17	31.06	5.8	53.05	104	195	Average
4874	41.35	57.54	74	-32.65	31.06	5.8	53.05	104	195	Peak

**REMARKS:**

- Emission Level = Read Level + Antenna Factor + Cable Loss - Preamp Factor  
Margin value = Emission level – Limit value
- 2437MHz: Fundamental frequency.





A D T

EUT TEST CONDITION		MEASUREMENT DETAIL	
CHANNEL	Channel 11	FREQUENCY RANGE	1GHz ~ 25GHz
INPUT POWER	120Vac, 60 Hz	DETECTOR FUNCTION	Peak (PK) Average (AV)
ENVIRONMENTAL CONDITIONS	25deg. C, 65%RH	TESTED BY	Gavin Wu

**ANTENNA POLARITY & TEST DISTANCE: HORIZONTAL AT 3 M**

FREQ. (MHz)	EMISSION LEVEL (dBuV/m)	READ LEVEL (dBuV)	LIMIT (dBuV/m)	MARGIN (dB)	ANTENNA FACTOR (dB/m)	CABLE LOSS (dB)	PREAMP FACTOR (dB)	ANTENNA HEIGHT (cm)	TABLE ANGLE (Degree)	REMARK
2384	34.92	42.04	54	-19.08	26.86	3.52	37.5	133	240	Average
2384	55.76	62.88	74	-18.24	26.86	3.52	37.5	133	240	Peak
2462	99.06	105.77			27.1	3.58	37.39	133	240	Average
2462	108.86	115.57			27.1	3.58	37.39	133	240	Peak
2484	52.99	59.56	54	-1.01	27.15	3.6	37.32	133	240	Average
2484	72.16	78.73	74	-1.84	27.15	3.6	37.32	133	240	Peak
4924	28.88	44.96	54	-25.12	31.12	5.83	53.03	120	220	Average
4924	38.11	54.19	74	-35.89	31.12	5.83	53.03	120	220	Peak

**ANTENNA POLARITY & TEST DISTANCE: VERTICAL AT 3 M**

FREQ. (MHz)	EMISSION LEVEL (dBuV/m)	READ LEVEL (dBuV)	LIMIT (dBuV/m)	MARGIN (dB)	ANTENNA FACTOR (dB/m)	CABLE LOSS (dB)	PREAMP FACTOR (dB)	ANTENNA HEIGHT (cm)	TABLE ANGLE (Degree)	REMARK
2332	33.06	40.33	54	-20.94	26.72	3.48	37.47	139	216	Average
2332	56.39	63.66	74	-17.61	26.72	3.48	37.47	139	216	Peak
2462	92.7	99.41			27.1	3.58	37.39	139	216	Average
2462	102.24	108.95			27.1	3.58	37.39	139	216	Peak
2484	45.68	52.25	54	-8.32	27.15	3.6	37.32	139	216	Average
2484	65.9	72.47	74	-8.1	27.15	3.6	37.32	139	216	Peak
4924	28.25	44.33	54	-25.75	31.12	5.83	53.03	110	269	Average
4924	37.49	53.57	74	-36.51	31.12	5.83	53.03	110	269	Peak

**REMARKS:**

- Emission Level = Read Level + Antenna Factor + Cable Loss - Preamp Factor  
Margin value = Emission level – Limit value
- 2462MHz: Fundamental frequency.



A D T

EUT TEST CONDITION		MEASUREMENT DETAIL	
CHANNEL	Channel 12	FREQUENCY RANGE	1GHz ~ 25GHz
INPUT POWER	120Vac, 60 Hz	DETECTOR FUNCTION	Peak (PK) Average (AV)
ENVIRONMENTAL CONDITIONS	25deg. C, 65%RH	TESTED BY	Gavin Wu

ANTENNA POLARITY & TEST DISTANCE: HORIZONTAL AT 3 M										
FREQ. (MHz)	EMISSION LEVEL (dBuV/m)	READ LEVEL (dBuV)	LIMIT (dBuV/m)	MARGIN (dB)	ANTENNA FACTOR (dB/m)	CABLE LOSS (dB)	PREAMP FACTOR (dB)	ANTENNA HEIGHT (cm)	TABLE ANGLE (Degree)	REMARK
2324	33.65	40.92	54	-20.35	26.72	3.48	37.47	105	222	Average
2324	57.11	64.38	74	-16.89	26.72	3.48	37.47	105	222	Peak
2467	80.51	87.13			27.1	3.6	37.32	105	222	Average
2467	90.94	97.56			27.1	3.6	37.32	105	222	Peak
2484	37.09	43.66	54	-16.91	27.15	3.6	37.32	105	222	Average
2484	60.03	66.6	74	-13.97	27.15	3.6	37.32	105	222	Peak
ANTENNA POLARITY & TEST DISTANCE: VERTICAL AT 3 M										
FREQ. (MHz)	EMISSION LEVEL (dBuV/m)	READ LEVEL (dBuV)	LIMIT (dBuV/m)	MARGIN (dB)	ANTENNA FACTOR (dB/m)	CABLE LOSS (dB)	PREAMP FACTOR (dB)	ANTENNA HEIGHT (cm)	TABLE ANGLE (Degree)	REMARK
2332	33.28	40.55	54	-20.72	26.72	3.48	37.47	117	188	Average
2332	57.02	64.29	74	-16.98	26.72	3.48	37.47	117	188	Peak
2467	74.49	81.11			27.1	3.6	37.32	117	188	Average
2467	85.01	91.63			27.1	3.6	37.32	117	188	Peak
2498	35.01	41.44	54	-18.99	27.2	3.62	37.25	117	188	Average
2498	57.75	64.18	74	-16.25	27.2	3.62	37.25	117	188	Peak

**REMARKS:**

- Emission Level = Read Level + Antenna Factor + Cable Loss - Preamp Factor  
Margin value = Emission level – Limit value
- 2467MHz: Fundamental frequency.



A D T

EUT TEST CONDITION		MEASUREMENT DETAIL	
CHANNEL	Channel 13	FREQUENCY RANGE	1GHz ~ 25GHz
INPUT POWER	120Vac, 60 Hz	DETECTOR FUNCTION	Peak (PK) Average (AV)
ENVIRONMENTAL CONDITIONS	25deg. C, 65%RH	TESTED BY	Gavin Wu

ANTENNA POLARITY & TEST DISTANCE: HORIZONTAL AT 3 M										
FREQ. (MHz)	EMISSION LEVEL (dBuV/m)	READ LEVEL (dBuV)	LIMIT (dBuV/m)	MARGIN (dB)	ANTENNA FACTOR (dB/m)	CABLE LOSS (dB)	PREAMP FACTOR (dB)	ANTENNA HEIGHT (cm)	TABLE ANGLE (Degree)	REMARK
2380	33.62	40.74	54	-20.38	26.86	3.52	37.5	103	223	Average
2380	56.94	64.06	74	-17.06	26.86	3.52	37.5	103	223	Peak
2472	78.68	85.25			27.15	3.6	37.32	103	223	Average
2472	89.15	95.72			27.15	3.6	37.32	103	223	Peak
2484	41.01	47.58	54	-12.99	27.15	3.6	37.32	103	223	Average
2484	69.58	76.15	74	-4.42	27.15	3.6	37.32	103	223	Peak
ANTENNA POLARITY & TEST DISTANCE: VERTICAL AT 3 M										
FREQ. (MHz)	EMISSION LEVEL (dBuV/m)	READ LEVEL (dBuV)	LIMIT (dBuV/m)	MARGIN (dB)	ANTENNA FACTOR (dB/m)	CABLE LOSS (dB)	PREAMP FACTOR (dB)	ANTENNA HEIGHT (cm)	TABLE ANGLE (Degree)	REMARK
2366	33.52	40.69	54	-20.48	26.81	3.52	37.5	115	188	Average
2366	56.79	63.96	74	-17.21	26.81	3.52	37.5	115	188	Peak
2472	72.55	79.12			27.15	3.6	37.32	115	188	Average
2472	83.11	89.68			27.15	3.6	37.32	115	188	Peak
2484	38.13	44.7	54	-15.87	27.15	3.6	37.32	115	188	Average
2484	64.75	71.32	74	-9.25	27.15	3.6	37.32	115	188	Peak

**REMARKS:**

- Emission Level = Read Level + Antenna Factor + Cable Loss - Preamp Factor  
Margin value = Emission level – Limit value
- 2472MHz: Fundamental frequency.



A D T

**Mode B**

**802.11b**

EUT TEST CONDITION		MEASUREMENT DETAIL	
CHANNEL	Channel 1	FREQUENCY RANGE	1GHz ~ 25GHz
INPUT POWER	120Vac, 60 Hz	DETECTOR FUNCTION	Peak (PK) Average (AV)
ENVIRONMENTAL CONDITIONS	25deg. C, 65%RH	TESTED BY	Gavin Wu

**ANTENNA POLARITY & TEST DISTANCE: HORIZONTAL AT 3 M**

FREQ. (MHz)	EMISSION LEVEL (dBuV/m)	READ LEVEL (dBuV)	LIMIT (dBuV/m)	MARGIN (dB)	ANTENNA FACTOR (dB/m)	CABLE LOSS (dB)	PREAMP FACTOR (dB)	ANTENNA HEIGHT (cm)	TABLE ANGLE (Degree)	REMARK
2390	52.42	59.49	54	-1.58	26.91	3.54	37.52	124	224	Average
2390	63.71	70.78	74	-10.29	26.91	3.54	37.52	124	224	Peak
2412	107.9	114.92			26.96	3.54	37.52	124	224	Average
2412	112.12	119.14			26.96	3.54	37.52	124	224	Peak
2496	39.66	46.09	54	-14.34	27.2	3.62	37.25	124	224	Average
2496	57.91	64.34	74	-16.09	27.2	3.62	37.25	124	224	Peak
4824	35.96	52.28	54	-18.04	30.99	5.77	53.08	100	253	Average
4824	41.49	57.81	74	-32.51	30.99	5.77	53.08	100	253	Peak

**ANTENNA POLARITY & TEST DISTANCE: VERTICAL AT 3 M**

FREQ. (MHz)	EMISSION LEVEL (dBuV/m)	READ LEVEL (dBuV)	LIMIT (dBuV/m)	MARGIN (dB)	ANTENNA FACTOR (dB/m)	CABLE LOSS (dB)	PREAMP FACTOR (dB)	ANTENNA HEIGHT (cm)	TABLE ANGLE (Degree)	REMARK
2390	46.63	53.7	54	-7.37	26.91	3.54	37.52	116	350	Average
2390	58.61	65.68	74	-15.39	26.91	3.54	37.52	116	350	Peak
2412	102.36	109.38			26.96	3.54	37.52	116	350	Average
2412	106.74	113.76			26.96	3.54	37.52	116	350	Peak
2496	36.26	42.69	54	-17.74	27.2	3.62	37.25	116	350	Average
2496	56.18	62.61	74	-17.82	27.2	3.62	37.25	116	350	Peak
4824	35.56	51.88	54	-18.44	30.99	5.77	53.08	167	182	Average
4824	42.4	58.72	74	-31.6	30.99	5.77	53.08	167	182	Peak

**REMARKS:**

- Emission Level = Read Level + Antenna Factor + Cable Loss - Preamp Factor  
Margin value = Emission level – Limit value
- 2412MHz: Fundamental frequency.



A D T

EUT TEST CONDITION		MEASUREMENT DETAIL	
CHANNEL	Channel 6	FREQUENCY RANGE	1GHz ~ 25GHz
INPUT POWER	120Vac, 60 Hz	DETECTOR FUNCTION	Peak (PK) Average (AV)
ENVIRONMENTAL CONDITIONS	25deg. C, 65%RH	TESTED BY	Gavin Wu

**ANTENNA POLARITY & TEST DISTANCE: HORIZONTAL AT 3 M**

FREQ. (MHz)	EMISSION LEVEL (dBuV/m)	READ LEVEL (dBuV)	LIMIT (dBuV/m)	MARGIN (dB)	ANTENNA FACTOR (dB/m)	CABLE LOSS (dB)	PREAMP FACTOR (dB)	ANTENNA HEIGHT (cm)	TABLE ANGLE (Degree)	REMARK
2386	44.21	51.28	54	-9.79	26.91	3.52	37.5	107	228	Average
2386	57.92	64.99	74	-16.08	26.91	3.52	37.5	107	228	Peak
2437	110.32	117.16			27.06	3.56	37.46	107	228	Average
2437	114.51	121.35			27.06	3.56	37.46	107	228	Peak
2486	49.05	55.62	54	-4.95	27.15	3.6	37.32	107	228	Average
2486	59.58	66.15	74	-14.42	27.15	3.6	37.32	107	228	Peak
4874	40.46	56.65	54	-13.54	31.06	5.8	53.05	102	133	Average
4874	43.4	59.59	74	-30.6	31.06	5.8	53.05	102	133	Peak

**ANTENNA POLARITY & TEST DISTANCE: VERTICAL AT 3 M**

FREQ. (MHz)	EMISSION LEVEL (dBuV/m)	READ LEVEL (dBuV)	LIMIT (dBuV/m)	MARGIN (dB)	ANTENNA FACTOR (dB/m)	CABLE LOSS (dB)	PREAMP FACTOR (dB)	ANTENNA HEIGHT (cm)	TABLE ANGLE (Degree)	REMARK
2380	40.54	47.66	54	-13.46	26.86	3.52	37.5	100	329	Average
2380	56.89	64.01	74	-17.11	26.86	3.52	37.5	100	329	Peak
2437	104.93	111.77			27.06	3.56	37.46	100	329	Average
2437	109.04	115.88			27.06	3.56	37.46	100	329	Peak
2484	43.69	50.26	54	-10.31	27.15	3.6	37.32	100	329	Average
2484	58	64.57	74	-16	27.15	3.6	37.32	100	329	Peak
4874	36.63	52.82	54	-17.37	31.06	5.8	53.05	132	209	Average
4874	40.64	56.83	74	-33.36	31.06	5.8	53.05	132	209	Peak

**REMARKS:**

- Emission Level = Read Level + Antenna Factor + Cable Loss - Preamp Factor  
Margin value = Emission level – Limit value
- 2437MHz: Fundamental frequency.



A D T

EUT TEST CONDITION		MEASUREMENT DETAIL	
CHANNEL	Channel 11	FREQUENCY RANGE	1GHz ~ 25GHz
INPUT POWER	120Vac, 60 Hz	DETECTOR FUNCTION	Peak (PK) Average (AV)
ENVIRONMENTAL CONDITIONS	25deg. C, 65%RH	TESTED BY	Gavin Wu

**ANTENNA POLARITY & TEST DISTANCE: HORIZONTAL AT 3 M**

FREQ. (MHz)	EMISSION LEVEL (dBuV/m)	READ LEVEL (dBuV)	LIMIT (dBuV/m)	MARGIN (dB)	ANTENNA FACTOR (dB/m)	CABLE LOSS (dB)	PREAMP FACTOR (dB)	ANTENNA HEIGHT (cm)	TABLE ANGLE (Degree)	REMARK
2344	38.36	45.58	54	-15.64	26.77	3.5	37.49	106	223	Average
2344	57.88	65.1	74	-16.12	26.77	3.5	37.49	106	223	Peak
2462	110.13	116.84			27.1	3.58	37.39	106	223	Average
2462	114.34	121.05			27.1	3.58	37.39	106	223	Peak
2490	50.92	57.42	54	-3.08	27.2	3.62	37.32	106	223	Average
2490	62.81	69.31	74	-11.19	27.2	3.62	37.32	106	223	Peak
4924	38.44	54.52	54	-15.56	31.12	5.83	53.03	135	255	Average
4924	44.95	61.03	74	-29.05	31.12	5.83	53.03	135	255	Peak

**ANTENNA POLARITY & TEST DISTANCE: VERTICAL AT 3 M**

FREQ. (MHz)	EMISSION LEVEL (dBuV/m)	READ LEVEL (dBuV)	LIMIT (dBuV/m)	MARGIN (dB)	ANTENNA FACTOR (dB/m)	CABLE LOSS (dB)	PREAMP FACTOR (dB)	ANTENNA HEIGHT (cm)	TABLE ANGLE (Degree)	REMARK
2360	34.28	41.46	54	-19.72	26.81	3.5	37.49	125	331	Average
2360	57.02	64.2	74	-16.98	26.81	3.5	37.49	125	331	Peak
2462	102.35	109.06			27.1	3.58	37.39	125	331	Average
2462	106.45	113.16			27.1	3.58	37.39	125	331	Peak
2484	41.79	48.36	54	-12.21	27.15	3.6	37.32	125	331	Average
2484	58.08	64.65	74	-15.92	27.15	3.6	37.32	125	331	Peak
4924	39.9	55.98	54	-14.1	31.12	5.83	53.03	108	162	Average
4924	44.38	60.46	74	-29.62	31.12	5.83	53.03	108	162	Peak

**REMARKS:**

- Emission Level = Read Level + Antenna Factor + Cable Loss - Preamp Factor  
Margin value = Emission level – Limit value
- 2462MHz: Fundamental frequency.



A D T

EUT TEST CONDITION		MEASUREMENT DETAIL	
CHANNEL	Channel 12	FREQUENCY RANGE	1GHz ~ 25GHz
INPUT POWER	120Vac, 60 Hz	DETECTOR FUNCTION	Peak (PK) Average (AV)
ENVIRONMENTAL CONDITIONS	25deg. C, 65%RH	TESTED BY	Gavin Wu

ANTENNA POLARITY & TEST DISTANCE: HORIZONTAL AT 3 M										
FREQ. (MHz)	EMISSION LEVEL (dBuV/m)	READ LEVEL (dBuV)	LIMIT (dBuV/m)	MARGIN (dB)	ANTENNA FACTOR (dB/m)	CABLE LOSS (dB)	PREAMP FACTOR (dB)	ANTENNA HEIGHT (cm)	TABLE ANGLE (Degree)	REMARK
2368	32.79	39.96	54	-21.21	26.81	3.52	37.5	132	238	Average
2368	57.52	64.69	74	-16.48	26.81	3.52	37.5	132	238	Peak
2467	78.98	85.6			27.1	3.6	37.32	132	238	Average
2467	83.88	90.5			27.1	3.6	37.32	132	238	Peak
2484	34.12	40.69	54	-19.88	27.15	3.6	37.32	132	238	Average
2484	56.8	63.37	74	-17.2	27.15	3.6	37.32	132	238	Peak
ANTENNA POLARITY & TEST DISTANCE: VERTICAL AT 3 M										
FREQ. (MHz)	EMISSION LEVEL (dBuV/m)	READ LEVEL (dBuV)	LIMIT (dBuV/m)	MARGIN (dB)	ANTENNA FACTOR (dB/m)	CABLE LOSS (dB)	PREAMP FACTOR (dB)	ANTENNA HEIGHT (cm)	TABLE ANGLE (Degree)	REMARK
2368	32.62	39.79	54	-21.38	26.81	3.52	37.5	116	346	Average
2368	55.88	63.05	74	-18.12	26.81	3.52	37.5	116	346	Peak
2467	72.8	79.42			27.1	3.6	37.32	116	346	Average
2467	78.41	85.03			27.1	3.6	37.32	116	346	Peak
2496	33.48	39.91	54	-20.52	27.2	3.62	37.25	116	346	Average
2496	56.2	62.63	74	-17.8	27.2	3.62	37.25	116	346	Peak

**REMARKS:**

- Emission Level = Read Level + Antenna Factor + Cable Loss - Preamp Factor  
Margin value = Emission level – Limit value
- 2467MHz: Fundamental frequency.



A D T

EUT TEST CONDITION		MEASUREMENT DETAIL	
CHANNEL	Channel 13	FREQUENCY RANGE	1GHz ~ 25GHz
INPUT POWER	120Vac, 60 Hz	DETECTOR FUNCTION	Peak (PK) Average (AV)
ENVIRONMENTAL CONDITIONS	25deg. C, 65%RH	TESTED BY	Gavin Wu

ANTENNA POLARITY & TEST DISTANCE: HORIZONTAL AT 3 M										
FREQ. (MHz)	EMISSION LEVEL (dBuV/m)	READ LEVEL (dBuV)	LIMIT (dBuV/m)	MARGIN (dB)	ANTENNA FACTOR (dB/m)	CABLE LOSS (dB)	PREAMP FACTOR (dB)	ANTENNA HEIGHT (cm)	TABLE ANGLE (Degree)	REMARK
2334	32.53	39.8	54	-21.47	26.72	3.48	37.47	122	247	Average
2334	57.07	64.34	74	-16.93	26.72	3.48	37.47	122	247	Peak
2472	78.66	85.23			27.15	3.6	37.32	122	247	Average
2472	84.21	90.78			27.15	3.6	37.32	122	247	Peak
2492	34.23	40.66	54	-19.77	27.2	3.62	37.25	122	247	Average
2492	57.2	63.63	74	-16.8	27.2	3.62	37.25	122	247	Peak
ANTENNA POLARITY & TEST DISTANCE: VERTICAL AT 3 M										
FREQ. (MHz)	EMISSION LEVEL (dBuV/m)	READ LEVEL (dBuV)	LIMIT (dBuV/m)	MARGIN (dB)	ANTENNA FACTOR (dB/m)	CABLE LOSS (dB)	PREAMP FACTOR (dB)	ANTENNA HEIGHT (cm)	TABLE ANGLE (Degree)	REMARK
2314	32.41	39.73	54	-21.59	26.67	3.48	37.47	115	348	Average
2314	56.51	63.83	74	-17.49	26.67	3.48	37.47	115	348	Peak
2472	72.94	79.51			27.15	3.6	37.32	115	348	Average
2472	78.63	85.2			27.15	3.6	37.32	115	348	Peak
2484	33.35	39.92	54	-20.65	27.15	3.6	37.32	115	348	Average
2484	56.86	63.43	74	-17.14	27.15	3.6	37.32	115	348	Peak

**REMARKS:**

- Emission Level = Read Level + Antenna Factor + Cable Loss - Preamp Factor  
Margin value = Emission level – Limit value
- 2472MHz: Fundamental frequency.





A D T

802.11g

EUT TEST CONDITION		MEASUREMENT DETAIL	
CHANNEL	Channel 1	FREQUENCY RANGE	1GHz ~ 25GHz
INPUT POWER	120Vac, 60 Hz	DETECTOR FUNCTION	Peak (PK) Average (AV)
ENVIRONMENTAL CONDITIONS	25deg. C, 65%RH	TESTED BY	Gavin Wu

**ANTENNA POLARITY & TEST DISTANCE: HORIZONTAL AT 3 M**

FREQ. (MHz)	EMISSION LEVEL (dBuV/m)	READ LEVEL (dBuV)	LIMIT (dBuV/m)	MARGIN (dB)	ANTENNA FACTOR (dB/m)	CABLE LOSS (dB)	PREAMP FACTOR (dB)	ANTENNA HEIGHT (cm)	TABLE ANGLE (Degree)	REMARK
2390	52.84	59.91	54	-1.16	26.91	3.54	37.52	110	234	Average
2390	72.7	79.77	74	-1.3	26.91	3.54	37.52	110	234	Peak
2412	101.12	108.14			26.96	3.54	37.52	110	234	Average
2412	111.9	118.92			26.96	3.54	37.52	110	234	Peak
2490	36.7	43.2	54	-17.3	27.2	3.62	37.32	110	234	Average
2490	56.71	63.21	74	-17.29	27.2	3.62	37.32	110	234	Peak
4824	29.1	45.42	54	-24.9	30.99	5.77	53.08	100	212	Average
4824	40.99	57.31	74	-33.01	30.99	5.77	53.08	100	212	Peak

**ANTENNA POLARITY & TEST DISTANCE: VERTICAL AT 3 M**

FREQ. (MHz)	EMISSION LEVEL (dBuV/m)	READ LEVEL (dBuV)	LIMIT (dBuV/m)	MARGIN (dB)	ANTENNA FACTOR (dB/m)	CABLE LOSS (dB)	PREAMP FACTOR (dB)	ANTENNA HEIGHT (cm)	TABLE ANGLE (Degree)	REMARK
2390	47.87	54.94	54	-6.13	26.91	3.54	37.52	100	343	Average
2390	68.76	75.83	74	-5.24	26.91	3.54	37.52	100	343	Peak
2412	95.86	102.88			26.96	3.54	37.52	100	343	Average
2412	106.88	113.9			26.96	3.54	37.52	100	343	Peak
2500	34.56	40.99	54	-19.44	27.2	3.62	37.25	100	343	Average
2500	56.78	63.21	74	-17.22	27.2	3.62	37.25	100	343	Peak
4824	29.03	45.35	54	-24.97	30.99	5.77	53.08	125	196	Average
4824	40.74	57.06	74	-33.26	30.99	5.77	53.08	125	196	Peak

**REMARKS:**

- Emission Level = Read Level + Antenna Factor + Cable Loss - Preamp Factor  
Margin value = Emission level – Limit value
- 2412MHz: Fundamental frequency.



A D T

EUT TEST CONDITION		MEASUREMENT DETAIL	
CHANNEL	Channel 6	FREQUENCY RANGE	1GHz ~ 25GHz
INPUT POWER	120Vac, 60 Hz	DETECTOR FUNCTION	Peak (PK) Average (AV)
ENVIRONMENTAL CONDITIONS	25deg. C, 65%RH	TESTED BY	Gavin Wu

**ANTENNA POLARITY & TEST DISTANCE: HORIZONTAL AT 3 M**

FREQ. (MHz)	EMISSION LEVEL (dBuV/m)	READ LEVEL (dBuV)	LIMIT (dBuV/m)	MARGIN (dB)	ANTENNA FACTOR (dB/m)	CABLE LOSS (dB)	PREAMP FACTOR (dB)	ANTENNA HEIGHT (cm)	TABLE ANGLE (Degree)	REMARK
2390	51.96	59.03	54	-2.04	26.91	3.54	37.52	109	224	Average
2390	70.1	77.17	74	-3.9	26.91	3.54	37.52	109	224	Peak
2437	106.38	113.22			27.06	3.56	37.46	109	224	Average
2437	116.27	123.11			27.06	3.56	37.46	109	224	Peak
2484	49.61	56.18	54	-4.39	27.15	3.6	37.32	109	224	Average
2484	66.11	72.68	74	-7.89	27.15	3.6	37.32	109	224	Peak
4874	29.37	45.56	54	-24.63	31.06	5.8	53.05	136	138	Average
4874	39.59	55.78	74	-34.41	31.06	5.8	53.05	136	138	Peak

**ANTENNA POLARITY & TEST DISTANCE: VERTICAL AT 3 M**

FREQ. (MHz)	EMISSION LEVEL (dBuV/m)	READ LEVEL (dBuV)	LIMIT (dBuV/m)	MARGIN (dB)	ANTENNA FACTOR (dB/m)	CABLE LOSS (dB)	PREAMP FACTOR (dB)	ANTENNA HEIGHT (cm)	TABLE ANGLE (Degree)	REMARK
2390	45.35	52.42	54	-8.65	26.91	3.54	37.52	127	332	Average
2390	62.89	69.96	74	-11.11	26.91	3.54	37.52	127	332	Peak
2437	100.3	107.14			27.06	3.56	37.46	127	332	Average
2437	110.41	117.25			27.06	3.56	37.46	127	332	Peak
2484	44.28	50.85	54	-9.72	27.15	3.6	37.32	127	332	Average
2484	65.63	72.2	74	-8.37	27.15	3.6	37.32	127	332	Peak
4874	29.18	45.37	54	-24.82	31.06	5.8	53.05	123	162	Average
4874	39.77	55.96	74	-34.23	31.06	5.8	53.05	123	162	Peak

**REMARKS:**

- Emission Level = Read Level + Antenna Factor + Cable Loss - Preamp Factor  
Margin value = Emission level – Limit value
- 2437MHz: Fundamental frequency.



A D T

EUT TEST CONDITION		MEASUREMENT DETAIL	
CHANNEL	Channel 11	FREQUENCY RANGE	1GHz ~ 25GHz
INPUT POWER	120Vac, 60 Hz	DETECTOR FUNCTION	Peak (PK) Average (AV)
ENVIRONMENTAL CONDITIONS	25deg. C, 65%RH	TESTED BY	Gavin Wu

**ANTENNA POLARITY & TEST DISTANCE: HORIZONTAL AT 3 M**

FREQ. (MHz)	EMISSION LEVEL (dBuV/m)	READ LEVEL (dBuV)	LIMIT (dBuV/m)	MARGIN (dB)	ANTENNA FACTOR (dB/m)	CABLE LOSS (dB)	PREAMP FACTOR (dB)	ANTENNA HEIGHT (cm)	TABLE ANGLE (Degree)	REMARK
2342	34.29	41.51	54	-19.71	26.77	3.5	37.49	137	229	Average
2342	56.79	64.01	74	-17.21	26.77	3.5	37.49	137	229	Peak
2462	101.82	108.53			27.1	3.58	37.39	137	229	Average
2462	112.09	118.8			27.1	3.58	37.39	137	229	Peak
2484	51.79	58.36	54	-2.21	27.15	3.6	37.32	137	229	Average
2484	72.47	79.04	74	-1.53	27.15	3.6	37.32	137	229	Peak
4924	28.83	44.91	54	-25.17	31.12	5.83	53.03	100	204	Average
4924	38.75	54.83	74	-35.25	31.12	5.83	53.03	100	204	Peak

**ANTENNA POLARITY & TEST DISTANCE: VERTICAL AT 3 M**

FREQ. (MHz)	EMISSION LEVEL (dBuV/m)	READ LEVEL (dBuV)	LIMIT (dBuV/m)	MARGIN (dB)	ANTENNA FACTOR (dB/m)	CABLE LOSS (dB)	PREAMP FACTOR (dB)	ANTENNA HEIGHT (cm)	TABLE ANGLE (Degree)	REMARK
2338	33.9	41.1	54	-20.1	26.77	3.5	37.47	135	343	Average
2338	56.89	64.09	74	-17.11	26.77	3.5	37.47	135	343	Peak
2462	94.66	101.37			27.1	3.58	37.39	135	343	Average
2462	105.75	112.46			27.1	3.58	37.39	135	343	Peak
2484	44.26	50.83	54	-9.74	27.15	3.6	37.32	135	343	Average
2484	65.87	72.44	74	-8.13	27.15	3.6	37.32	135	343	Peak
4924	28.76	44.84	54	-25.24	31.12	5.83	53.03	122	158	Average
4924	39.99	56.07	74	-34.01	31.12	5.83	53.03	122	158	Peak

**REMARKS:**

- Emission Level = Read Level + Antenna Factor + Cable Loss - Preamp Factor  
Margin value = Emission level – Limit value
- 2462MHz: Fundamental frequency.



A D T

EUT TEST CONDITION		MEASUREMENT DETAIL	
CHANNEL	Channel 12	FREQUENCY RANGE	1GHz ~ 25GHz
INPUT POWER	120Vac, 60 Hz	DETECTOR FUNCTION	Peak (PK) Average (AV)
ENVIRONMENTAL CONDITIONS	25deg. C, 65%RH	TESTED BY	Gavin Wu

ANTENNA POLARITY & TEST DISTANCE: HORIZONTAL AT 3 M										
FREQ. (MHz)	EMISSION LEVEL (dBuV/m)	READ LEVEL (dBuV)	LIMIT (dBuV/m)	MARGIN (dB)	ANTENNA FACTOR (dB/m)	CABLE LOSS (dB)	PREAMP FACTOR (dB)	ANTENNA HEIGHT (cm)	TABLE ANGLE (Degree)	REMARK
2322	33.5	40.77	54	-20.5	26.72	3.48	37.47	131	240	Average
2322	56.26	63.53	74	-17.74	26.72	3.48	37.47	131	240	Peak
2467	79.11	85.73			27.1	3.6	37.32	131	240	Average
2467	88.79	95.41			27.1	3.6	37.32	131	240	Peak
2496	35.77	42.2	54	-18.23	27.2	3.62	37.25	131	240	Average
2496	57.49	63.92	74	-16.51	27.2	3.62	37.25	131	240	Peak
ANTENNA POLARITY & TEST DISTANCE: VERTICAL AT 3 M										
FREQ. (MHz)	EMISSION LEVEL (dBuV/m)	READ LEVEL (dBuV)	LIMIT (dBuV/m)	MARGIN (dB)	ANTENNA FACTOR (dB/m)	CABLE LOSS (dB)	PREAMP FACTOR (dB)	ANTENNA HEIGHT (cm)	TABLE ANGLE (Degree)	REMARK
2358	33.43	40.61	54	-20.57	26.81	3.5	37.49	117	315	Average
2358	57.17	64.35	74	-16.83	26.81	3.5	37.49	117	315	Peak
2467	72.1	78.72			27.1	3.6	37.32	117	315	Average
2467	82.86	89.48			27.1	3.6	37.32	117	315	Peak
2488	34.76	41.26	54	-19.24	27.2	3.62	37.32	117	315	Average
2488	58.1	64.6	74	-15.9	27.2	3.62	37.32	117	315	Peak

**REMARKS:**

- Emission Level = Read Level + Antenna Factor + Cable Loss - Preamp Factor  
Margin value = Emission level – Limit value
- 2467MHz: Fundamental frequency.



A D T

EUT TEST CONDITION		MEASUREMENT DETAIL	
CHANNEL	Channel 13	FREQUENCY RANGE	1GHz ~ 25GHz
INPUT POWER	120Vac, 60 Hz	DETECTOR FUNCTION	Peak (PK) Average (AV)
ENVIRONMENTAL CONDITIONS	25deg. C, 65%RH	TESTED BY	Gavin Wu

ANTENNA POLARITY & TEST DISTANCE: HORIZONTAL AT 3 M										
FREQ. (MHz)	EMISSION LEVEL (dBuV/m)	READ LEVEL (dBuV)	LIMIT (dBuV/m)	MARGIN (dB)	ANTENNA FACTOR (dB/m)	CABLE LOSS (dB)	PREAMP FACTOR (dB)	ANTENNA HEIGHT (cm)	TABLE ANGLE (Degree)	REMARK
2380	33.61	40.73	54	-20.39	26.86	3.52	37.5	127	239	Average
2380	55.92	63.04	74	-18.08	26.86	3.52	37.5	127	239	Peak
2472	80.99	87.56			27.15	3.6	37.32	127	239	Average
2472	90.66	97.23			27.15	3.6	37.32	127	239	Peak
2484	40.78	47.35	54	-13.22	27.15	3.6	37.32	127	239	Average
2484	68.93	75.5	74	-5.07	27.15	3.6	37.32	127	239	Peak
ANTENNA POLARITY & TEST DISTANCE: VERTICAL AT 3 M										
FREQ. (MHz)	EMISSION LEVEL (dBuV/m)	READ LEVEL (dBuV)	LIMIT (dBuV/m)	MARGIN (dB)	ANTENNA FACTOR (dB/m)	CABLE LOSS (dB)	PREAMP FACTOR (dB)	ANTENNA HEIGHT (cm)	TABLE ANGLE (Degree)	REMARK
2354	33.52	40.7	54	-20.48	26.81	3.5	37.49	117	342	Average
2354	57.04	64.22	74	-16.96	26.81	3.5	37.49	117	342	Peak
2472	73.03	79.6			27.15	3.6	37.32	117	342	Average
2472	83.73	90.3			27.15	3.6	37.32	117	342	Peak
2484	37.31	43.88	54	-16.69	27.15	3.6	37.32	117	342	Average
2484	63.81	70.38	74	-10.19	27.15	3.6	37.32	117	342	Peak

**REMARKS:**

- Emission Level = Read Level + Antenna Factor + Cable Loss - Preamp Factor  
Margin value = Emission level – Limit value
- 2472MHz: Fundamental frequency.



A D T

**802.11n (20MHz)**

EUT TEST CONDITION		MEASUREMENT DETAIL	
CHANNEL	Channel 1	FREQUENCY RANGE	1GHz ~ 25GHz
INPUT POWER	120Vac, 60 Hz	DETECTOR FUNCTION	Peak (PK) Average (AV)
ENVIRONMENTAL CONDITIONS	25deg. C, 65%RH	TESTED BY	Gavin Wu

**ANTENNA POLARITY & TEST DISTANCE: HORIZONTAL AT 3 M**

FREQ. (MHz)	EMISSION LEVEL (dBuV/m)	READ LEVEL (dBuV)	LIMIT (dBuV/m)	MARGIN (dB)	ANTENNA FACTOR (dB/m)	CABLE LOSS (dB)	PREAMP FACTOR (dB)	ANTENNA HEIGHT (cm)	TABLE ANGLE (Degree)	REMARK
2390	52.18	59.25	54	-1.82	26.91	3.54	37.52	124	224	Average
2390	70.65	77.72	74	-3.35	26.91	3.54	37.52	124	224	Peak
2412	99.38	106.4			26.96	3.54	37.52	124	224	Average
2412	110.78	117.8			26.96	3.54	37.52	124	224	Peak
2488	37	43.5	54	-17	27.2	3.62	37.32	124	224	Average
2488	58.1	64.6	74	-15.9	27.2	3.62	37.32	124	224	Peak
4824	33.34	49.66	54	-20.66	30.99	5.77	53.08	100	175	Average
4824	45.98	62.3	74	-28.02	30.99	5.77	53.08	100	175	Peak

**ANTENNA POLARITY & TEST DISTANCE: VERTICAL AT 3 M**

FREQ. (MHz)	EMISSION LEVEL (dBuV/m)	READ LEVEL (dBuV)	LIMIT (dBuV/m)	MARGIN (dB)	ANTENNA FACTOR (dB/m)	CABLE LOSS (dB)	PREAMP FACTOR (dB)	ANTENNA HEIGHT (cm)	TABLE ANGLE (Degree)	REMARK
2388	48.69	55.74	54	-5.31	26.91	3.54	37.5	102	345	Average
2388	68.31	75.36	74	-5.69	26.91	3.54	37.5	102	345	Peak
2412	94.71	101.73			26.96	3.54	37.52	102	345	Average
2412	105.9	112.92			26.96	3.54	37.52	102	345	Peak
2494	34.8	41.23	54	-19.2	27.2	3.62	37.25	102	345	Average
2494	56.71	63.14	74	-17.29	27.2	3.62	37.25	102	345	Peak
4824	29.89	46.21	54	-24.11	30.99	5.77	53.08	125	211	Average
4824	39.54	55.86	74	-34.46	30.99	5.77	53.08	125	211	Peak

**REMARKS:**

- Emission Level = Read Level + Antenna Factor + Cable Loss - Preamp Factor  
Margin value = Emission level – Limit value
- 2412MHz: Fundamental frequency.



A D T

EUT TEST CONDITION		MEASUREMENT DETAIL	
CHANNEL	Channel 6	FREQUENCY RANGE	1GHz ~ 25GHz
INPUT POWER	120Vac, 60 Hz	DETECTOR FUNCTION	Peak (PK) Average (AV)
ENVIRONMENTAL CONDITIONS	25deg. C, 65%RH	TESTED BY	Gavin Wu

ANTENNA POLARITY & TEST DISTANCE: HORIZONTAL AT 3 M										
FREQ. (MHz)	EMISSION LEVEL (dBuV/m)	READ LEVEL (dBuV)	LIMIT (dBuV/m)	MARGIN (dB)	ANTENNA FACTOR (dB/m)	CABLE LOSS (dB)	PREAMP FACTOR (dB)	ANTENNA HEIGHT (cm)	TABLE ANGLE (Degree)	REMARK
2390	52.12	59.19	54	-1.88	26.91	3.54	37.52	109	225	Average
2390	71.62	78.69	74	-2.38	26.91	3.54	37.52	109	225	Peak
2437	106.01	112.85			27.06	3.56	37.46	109	225	Average
2437	116.72	123.56			27.06	3.56	37.46	109	225	Peak
2484	50.01	56.58	54	-3.99	27.15	3.6	37.32	109	225	Average
2484	67.71	74.28	74	-6.29	27.15	3.6	37.32	109	225	Peak
4874	30.69	46.88	54	-23.31	31.06	5.8	53.05	150	265	Average
4874	39.49	55.68	74	-34.51	31.06	5.8	53.05	150	265	Peak
ANTENNA POLARITY & TEST DISTANCE: VERTICAL AT 3 M										
FREQ. (MHz)	EMISSION LEVEL (dBuV/m)	READ LEVEL (dBuV)	LIMIT (dBuV/m)	MARGIN (dB)	ANTENNA FACTOR (dB/m)	CABLE LOSS (dB)	PREAMP FACTOR (dB)	ANTENNA HEIGHT (cm)	TABLE ANGLE (Degree)	REMARK
2384	46.03	53.15	54	-7.97	26.86	3.52	37.5	101	329	Average
2384	65.28	72.4	74	-8.72	26.86	3.52	37.5	101	329	Peak
2437	99.66	106.5			27.06	3.56	37.46	101	329	Average
2437	109.81	116.65			27.06	3.56	37.46	101	329	Peak
2484	43.49	50.06	54	-10.51	27.15	3.6	37.32	101	329	Average
2484	61.88	68.45	74	-12.12	27.15	3.6	37.32	101	329	Peak
4874	30.44	46.63	54	-23.56	31.06	5.8	53.05	120	180	Average
4874	41.6	57.79	74	-32.4	31.06	5.8	53.05	120	180	Peak

**REMARKS:**

- Emission Level = Read Level + Antenna Factor + Cable Loss - Preamp Factor  
Margin value = Emission level – Limit value
- 2437MHz: Fundamental frequency.



A D T

EUT TEST CONDITION		MEASUREMENT DETAIL	
CHANNEL	Channel 11	FREQUENCY RANGE	1GHz ~ 25GHz
INPUT POWER	120Vac, 60 Hz	DETECTOR FUNCTION	Peak (PK) Average (AV)
ENVIRONMENTAL CONDITIONS	25deg. C, 65%RH	TESTED BY	Gavin Wu

**ANTENNA POLARITY & TEST DISTANCE: HORIZONTAL AT 3 M**

FREQ. (MHz)	EMISSION LEVEL (dBuV/m)	READ LEVEL (dBuV)	LIMIT (dBuV/m)	MARGIN (dB)	ANTENNA FACTOR (dB/m)	CABLE LOSS (dB)	PREAMP FACTOR (dB)	ANTENNA HEIGHT (cm)	TABLE ANGLE (Degree)	REMARK
2318	34.92	42.19	54	-19.08	26.72	3.48	37.47	106	226	Average
2318	57.15	64.42	74	-16.85	26.72	3.48	37.47	106	226	Peak
2462	99.35	106.06			27.1	3.58	37.39	106	226	Average
2462	109.58	116.29			27.1	3.58	37.39	106	226	Peak
2484	51.83	58.4	54	-2.17	27.15	3.6	37.32	106	226	Average
2484	72.69	79.26	74	-1.31	27.15	3.6	37.32	106	226	Peak
4924	29.85	45.93	54	-24.15	31.12	5.83	53.03	100	266	Average
4924	40.36	56.44	74	-33.64	31.12	5.83	53.03	100	266	Peak

**ANTENNA POLARITY & TEST DISTANCE: VERTICAL AT 3 M**

FREQ. (MHz)	EMISSION LEVEL (dBuV/m)	READ LEVEL (dBuV)	LIMIT (dBuV/m)	MARGIN (dB)	ANTENNA FACTOR (dB/m)	CABLE LOSS (dB)	PREAMP FACTOR (dB)	ANTENNA HEIGHT (cm)	TABLE ANGLE (Degree)	REMARK
2388	35.44	42.49	54	-18.56	26.91	3.54	37.5	119	190	Average
2388	57.84	64.89	74	-16.16	26.91	3.54	37.5	119	190	Peak
2462	96.69	103.4			27.1	3.58	37.39	119	190	Average
2462	107.15	113.86			27.1	3.58	37.39	119	190	Peak
2484	47.14	53.71	54	-6.86	27.15	3.6	37.32	119	190	Average
2484	70.6	77.17	74	-3.4	27.15	3.6	37.32	119	190	Peak
4924	29.77	45.85	54	-24.23	31.12	5.83	53.03	129	175	Average
4924	39.71	55.79	74	-34.29	31.12	5.83	53.03	129	175	Peak

**REMARKS:**

- Emission Level = Read Level + Antenna Factor + Cable Loss - Preamp Factor  
Margin value = Emission level – Limit value
- 2462MHz: Fundamental frequency.





A D T

EUT TEST CONDITION		MEASUREMENT DETAIL	
CHANNEL	Channel 12	FREQUENCY RANGE	1GHz ~ 25GHz
INPUT POWER	120Vac, 60 Hz	DETECTOR FUNCTION	Peak (PK) Average (AV)
ENVIRONMENTAL CONDITIONS	25deg. C, 65%RH	TESTED BY	Gavin Wu

ANTENNA POLARITY & TEST DISTANCE: HORIZONTAL AT 3 M										
FREQ. (MHz)	EMISSION LEVEL (dBuV/m)	READ LEVEL (dBuV)	LIMIT (dBuV/m)	MARGIN (dB)	ANTENNA FACTOR (dB/m)	CABLE LOSS (dB)	PREAMP FACTOR (dB)	ANTENNA HEIGHT (cm)	TABLE ANGLE (Degree)	REMARK
2320	33.53	40.8	54	-20.47	26.72	3.48	37.47	130	243	Average
2320	57.32	64.59	74	-16.68	26.72	3.48	37.47	130	243	Peak
2467	78.52	85.14			27.1	3.6	37.32	130	243	Average
2467	88.69	95.31			27.1	3.6	37.32	130	243	Peak
2484	36.1	42.67	54	-17.9	27.15	3.6	37.32	130	243	Average
2484	58.14	64.71	74	-15.86	27.15	3.6	37.32	130	243	Peak
ANTENNA POLARITY & TEST DISTANCE: VERTICAL AT 3 M										
FREQ. (MHz)	EMISSION LEVEL (dBuV/m)	READ LEVEL (dBuV)	LIMIT (dBuV/m)	MARGIN (dB)	ANTENNA FACTOR (dB/m)	CABLE LOSS (dB)	PREAMP FACTOR (dB)	ANTENNA HEIGHT (cm)	TABLE ANGLE (Degree)	REMARK
2380	33.52	40.64	54	-20.48	26.86	3.52	37.5	116	314	Average
2380	56.18	63.3	74	-17.82	26.86	3.52	37.5	116	314	Peak
2467	71.33	77.95			27.1	3.6	37.32	116	314	Average
2467	81.09	87.71			27.1	3.6	37.32	116	314	Peak
2500	34.8	41.23	54	-19.2	27.2	3.62	37.25	116	314	Average
2500	56.56	62.99	74	-17.44	27.2	3.62	37.25	116	314	Peak

**REMARKS:**

- Emission Level = Read Level + Antenna Factor + Cable Loss - Preamp Factor  
Margin value = Emission level – Limit value
- 2467MHz: Fundamental frequency.



A D T

EUT TEST CONDITION		MEASUREMENT DETAIL	
CHANNEL	Channel 13	FREQUENCY RANGE	1GHz ~ 25GHz
INPUT POWER	120Vac, 60 Hz	DETECTOR FUNCTION	Peak (PK) Average (AV)
ENVIRONMENTAL CONDITIONS	25deg. C, 65%RH	TESTED BY	Gavin Wu

ANTENNA POLARITY & TEST DISTANCE: HORIZONTAL AT 3 M										
FREQ. (MHz)	EMISSION LEVEL (dBuV/m)	READ LEVEL (dBuV)	LIMIT (dBuV/m)	MARGIN (dB)	ANTENNA FACTOR (dB/m)	CABLE LOSS (dB)	PREAMP FACTOR (dB)	ANTENNA HEIGHT (cm)	TABLE ANGLE (Degree)	REMARK
2376	33.63	40.75	54	-20.37	26.86	3.52	37.5	129	240	Average
2376	56.48	63.6	74	-17.52	26.86	3.52	37.5	129	240	Peak
2472	77.69	84.26			27.15	3.6	37.32	129	240	Average
2472	87.68	94.25			27.15	3.6	37.32	129	240	Peak
2484	40.15	46.72	54	-13.85	27.15	3.6	37.32	129	240	Average
2484	66.95	73.52	74	-7.05	27.15	3.6	37.32	129	240	Peak
ANTENNA POLARITY & TEST DISTANCE: VERTICAL AT 3 M										
FREQ. (MHz)	EMISSION LEVEL (dBuV/m)	READ LEVEL (dBuV)	LIMIT (dBuV/m)	MARGIN (dB)	ANTENNA FACTOR (dB/m)	CABLE LOSS (dB)	PREAMP FACTOR (dB)	ANTENNA HEIGHT (cm)	TABLE ANGLE (Degree)	REMARK
2344	33.45	40.67	54	-20.55	26.77	3.5	37.49	124	329	Average
2344	56.78	64	74	-17.22	26.77	3.5	37.49	124	329	Peak
2472	70.15	76.72			27.15	3.6	37.32	124	329	Average
2472	80.38	86.95			27.15	3.6	37.32	124	329	Peak
2484	37.58	44.15	54	-16.42	27.15	3.6	37.32	124	329	Average
2484	63.29	69.86	74	-10.71	27.15	3.6	37.32	124	329	Peak

**REMARKS:**

- Emission Level = Read Level + Antenna Factor + Cable Loss - Preamp Factor  
Margin value = Emission level – Limit value
- 2472MHz: Fundamental frequency.



A D T

**BELOW 1GHz WORST-CASE DATA:**

**Mode A**

**802.11b**

EUT TEST CONDITION		MEASUREMENT DETAIL	
CHANNEL	Channel 1	FREQUENCY RANGE	30MHz ~ 1GHz
INPUT POWER	120Vac, 60 Hz	DETECTOR FUNCTION	Peak (PK)
ENVIRONMENTAL CONDITIONS	25deg. C, 65%RH	TESTED BY	Gavin Wu

**ANTENNA POLARITY & TEST DISTANCE: HORIZONTAL AT 3 M**

FREQ. (MHz)	EMISSION LEVEL (dBuV/m)	READ LEVEL (dBuV)	LIMIT (dBuV/m)	MARGIN (dB)	ANTENNA FACTOR (dB/m)	CABLE LOSS (dB)	PREAMP FACTOR (dB)	ANTENNA HEIGHT (cm)	TABLE ANGLE (Degree)	REMARK
83.46	22.03	44.51	40	-17.97	8.18	0.99	31.65	125	217	Peak
126.39	26.88	46.13	43.5	-16.62	11.42	1.22	31.89	105	242	Peak
187.95	30.82	50.79	43.5	-12.68	10.19	1.54	31.7	139	108	Peak
317.5	23.12	39.56	46	-22.88	13.36	2.11	31.91	112	187	Peak
458.9	23.58	36.42	46	-22.42	16.5	2.65	31.99	135	347	Peak
543.6	23.71	34.29	46	-22.29	18.3	2.92	31.8	104	160	Peak

**ANTENNA POLARITY & TEST DISTANCE: VERTICAL AT 3 M**

FREQ. (MHz)	EMISSION LEVEL (dBuV/m)	READ LEVEL (dBuV)	LIMIT (dBuV/m)	MARGIN (dB)	ANTENNA FACTOR (dB/m)	CABLE LOSS (dB)	PREAMP FACTOR (dB)	ANTENNA HEIGHT (cm)	TABLE ANGLE (Degree)	REMARK
30.54	24.85	43.26	40	-15.15	12.14	0.57	31.12	100	355	Peak
83.46	32.15	54.63	40	-7.85	8.18	0.99	31.65	127	146	Peak
126.12	33.74	52.99	43.5	-9.76	11.42	1.22	31.89	131	95	Peak
358.8	18.4	33.74	46	-27.6	14.36	2.26	31.96	125	286	Peak
437.2	20.86	34.21	46	-25.14	16.08	2.57	32	107	12	Peak
565.3	23.45	33.72	46	-22.55	18.81	2.99	32.07	134	176	Peak

**REMARKS:** Emission Level = Read Level + Antenna Factor + Cable Loss - Preamp Factor

Margin value = Emission level – Limit value



A D T

EUT TEST CONDITION		MEASUREMENT DETAIL	
CHANNEL	Channel 6	FREQUENCY RANGE	30MHz ~ 1GHz
INPUT POWER	120Vac, 60 Hz	DETECTOR FUNCTION	Peak (PK)
ENVIRONMENTAL CONDITIONS	25deg. C, 65%RH	TESTED BY	Gavin Wu

ANTENNA POLARITY & TEST DISTANCE: HORIZONTAL AT 3 M										
FREQ. (MHz)	EMISSION LEVEL (dBuV/m)	READ LEVEL (dBuV)	LIMIT (dBuV/m)	MARGIN (dB)	ANTENNA FACTOR (dB/m)	CABLE LOSS (dB)	PREAMP FACTOR (dB)	ANTENNA HEIGHT (cm)	TABLE ANGLE (Degree)	REMARK
83.46	23.94	46.42	40	-16.06	8.18	0.99	31.65	119	34	Peak
126.12	27.06	46.31	43.5	-16.44	11.42	1.22	31.89	122	35	Peak
189.3	30.11	50.14	43.5	-13.39	10.12	1.54	31.69	118	89	Peak
318.9	22.4	38.78	46	-23.6	13.4	2.12	31.9	106	305	Peak
415.5	22.05	35.95	46	-23.95	15.64	2.48	32.02	104	92	Peak
577.9	23.95	33.93	46	-22.05	19.1	3.03	32.11	113	272	Peak

ANTENNA POLARITY & TEST DISTANCE: VERTICAL AT 3 M										
FREQ. (MHz)	EMISSION LEVEL (dBuV/m)	READ LEVEL (dBuV)	LIMIT (dBuV/m)	MARGIN (dB)	ANTENNA FACTOR (dB/m)	CABLE LOSS (dB)	PREAMP FACTOR (dB)	ANTENNA HEIGHT (cm)	TABLE ANGLE (Degree)	REMARK
30.54	26.77	45.18	40	-13.23	12.14	0.57	31.12	108	263	Peak
83.19	33.32	55.8	40	-6.68	8.18	0.99	31.65	119	296	Peak
126.12	33.87	53.12	43.5	-9.63	11.42	1.22	31.89	120	357	Peak
311.2	18.47	35.1	46	-27.53	13.22	2.09	31.94	129	303	Peak
421.8	19.55	33.31	46	-26.45	15.77	2.51	32.04	127	143	Peak
534.5	22.59	33.3	46	-23.41	18.1	2.9	31.71	127	273	Peak

**REMARKS:** Emission Level = Read Level + Antenna Factor + Cable Loss - Preamp Factor  
 Margin value = Emission level – Limit value



A D T

EUT TEST CONDITION		MEASUREMENT DETAIL	
CHANNEL	Channel 11	FREQUENCY RANGE	30MHz ~ 1GHz
INPUT POWER	120Vac, 60 Hz	DETECTOR FUNCTION	Peak (PK)
ENVIRONMENTAL CONDITIONS	25deg. C, 65%RH	TESTED BY	Gavin Wu

ANTENNA POLARITY & TEST DISTANCE: HORIZONTAL AT 3 M										
FREQ. (MHz)	EMISSION LEVEL (dBuV/m)	READ LEVEL (dBuV)	LIMIT (dBuV/m)	MARGIN (dB)	ANTENNA FACTOR (dB/m)	CABLE LOSS (dB)	PREAMP FACTOR (dB)	ANTENNA HEIGHT (cm)	TABLE ANGLE (Degree)	REMARK
83.46	23.03	45.51	40	-16.97	8.18	0.99	31.65	125	249	Peak
126.66	27.42	46.61	43.5	-16.08	11.48	1.22	31.89	139	185	Peak
188.76	29.92	49.95	43.5	-13.58	10.12	1.54	31.69	140	341	Peak
311.2	22.19	38.82	46	-23.81	13.22	2.09	31.94	114	204	Peak
437.2	21.47	34.82	46	-24.53	16.08	2.57	32	104	65	Peak
538	22.86	33.48	46	-23.14	18.19	2.91	31.72	133	155	Peak

ANTENNA POLARITY & TEST DISTANCE: VERTICAL AT 3 M										
FREQ. (MHz)	EMISSION LEVEL (dBuV/m)	READ LEVEL (dBuV)	LIMIT (dBuV/m)	MARGIN (dB)	ANTENNA FACTOR (dB/m)	CABLE LOSS (dB)	PREAMP FACTOR (dB)	ANTENNA HEIGHT (cm)	TABLE ANGLE (Degree)	REMARK
30.54	26.39	44.8	40	-13.61	12.14	0.57	31.12	130	71	Peak
83.19	30.82	53.3	40	-9.18	8.18	0.99	31.65	128	321	Peak
125.58	31.88	51.13	43.5	-11.62	11.42	1.22	31.89	100	239	Peak
360.2	18.74	34.06	46	-27.26	14.38	2.27	31.97	134	323	Peak
479.2	22.39	34.62	46	-23.61	16.91	2.71	31.85	130	201	Peak
586.3	24.04	33.82	46	-21.96	19.3	3.05	32.13	104	207	Peak

**REMARKS:** Emission Level = Read Level + Antenna Factor + Cable Loss - Preamp Factor  
 Margin value = Emission level – Limit value



A D T

EUT TEST CONDITION		MEASUREMENT DETAIL	
CHANNEL	Channel 12	FREQUENCY RANGE	30MHz ~ 1GHz
INPUT POWER	120Vac, 60 Hz	DETECTOR FUNCTION	Peak (PK)
ENVIRONMENTAL CONDITIONS	25deg. C, 65%RH	TESTED BY	Gavin Wu

ANTENNA POLARITY & TEST DISTANCE: HORIZONTAL AT 3 M										
FREQ. (MHz)	EMISSION LEVEL (dBuV/m)	READ LEVEL (dBuV)	LIMIT (dBuV/m)	MARGIN (dB)	ANTENNA FACTOR (dB/m)	CABLE LOSS (dB)	PREAMP FACTOR (dB)	ANTENNA HEIGHT (cm)	TABLE ANGLE (Degree)	REMARK
84.27	21.61	44.11	40	-18.39	8.2	0.99	31.69	127	14	Peak
124.23	25.05	44.45	43.5	-18.45	11.28	1.21	31.89	126	108	Peak
208.74	27.88	48.14	43.5	-15.62	9.73	1.63	31.62	105	103	Peak
318.9	21.17	37.55	46	-24.83	13.4	2.12	31.9	111	250	Peak
464.5	19.63	32.29	46	-26.37	16.62	2.66	31.94	139	274	Peak
603.1	22.68	32.13	46	-23.32	19.65	3.1	32.2	128	229	Peak
ANTENNA POLARITY & TEST DISTANCE: VERTICAL AT 3 M										
FREQ. (MHz)	EMISSION LEVEL (dBuV/m)	READ LEVEL (dBuV)	LIMIT (dBuV/m)	MARGIN (dB)	ANTENNA FACTOR (dB/m)	CABLE LOSS (dB)	PREAMP FACTOR (dB)	ANTENNA HEIGHT (cm)	TABLE ANGLE (Degree)	REMARK
31.35	23.16	41.57	40	-16.84	12.14	0.57	31.12	110	258	Peak
84	28.14	50.64	40	-11.86	8.2	0.99	31.69	114	344	Peak
128.28	30.28	49.38	43.5	-13.22	11.55	1.23	31.88	102	28	Peak
333.6	15.88	31.77	46	-30.12	13.75	2.17	31.81	139	185	Peak
448.4	20.03	33.11	46	-25.97	16.29	2.61	31.98	117	58	Peak
654.2	23.09	31.55	46	-22.91	20.27	3.26	31.99	102	325	Peak

**REMARKS:** Emission Level = Read Level + Antenna Factor + Cable Loss - Preamp Factor  
 Margin value = Emission level – Limit value



A D T

EUT TEST CONDITION		MEASUREMENT DETAIL	
CHANNEL	Channel 13	FREQUENCY RANGE	30MHz ~ 1GHz
INPUT POWER	120Vac, 60 Hz	DETECTOR FUNCTION	Peak (PK)
ENVIRONMENTAL CONDITIONS	25deg. C, 65%RH	TESTED BY	Gavin Wu

ANTENNA POLARITY & TEST DISTANCE: HORIZONTAL AT 3 M										
FREQ. (MHz)	EMISSION LEVEL (dBuV/m)	READ LEVEL (dBuV)	LIMIT (dBuV/m)	MARGIN (dB)	ANTENNA FACTOR (dB/m)	CABLE LOSS (dB)	PREAMP FACTOR (dB)	ANTENNA HEIGHT (cm)	TABLE ANGLE (Degree)	REMARK
82.92	22.21	44.69	40	-17.79	8.18	0.99	31.65	115	186	Peak
128.01	26.56	45.66	43.5	-16.94	11.55	1.23	31.88	105	340	Peak
207.39	28.53	48.85	43.5	-14.97	9.69	1.63	31.64	110	57	Peak
311.9	20.05	36.65	46	-25.95	13.24	2.1	31.94	112	56	Peak
473.6	19.48	31.88	46	-26.52	16.79	2.69	31.88	111	230	Peak
660.5	22.94	31.26	46	-23.06	20.34	3.28	31.94	108	198	Peak
ANTENNA POLARITY & TEST DISTANCE: VERTICAL AT 3 M										
FREQ. (MHz)	EMISSION LEVEL (dBuV/m)	READ LEVEL (dBuV)	LIMIT (dBuV/m)	MARGIN (dB)	ANTENNA FACTOR (dB/m)	CABLE LOSS (dB)	PREAMP FACTOR (dB)	ANTENNA HEIGHT (cm)	TABLE ANGLE (Degree)	REMARK
31.35	23.19	41.6	40	-16.81	12.14	0.57	31.12	104	147	Peak
84	30.7	53.2	40	-9.3	8.2	0.99	31.69	124	115	Peak
128.28	32.48	51.58	43.5	-11.02	11.55	1.23	31.88	120	354	Peak
367.9	16.85	31.92	46	-29.15	14.56	2.3	31.93	113	121	Peak
489	20.52	32.46	46	-25.48	17.1	2.74	31.78	135	241	Peak
680.8	25.17	33.06	46	-20.83	20.59	3.36	31.84	138	225	Peak

**REMARKS:** Emission Level = Read Level + Antenna Factor + Cable Loss - Preamp Factor  
Margin value = Emission level – Limit value



A D T

802.11g

EUT TEST CONDITION		MEASUREMENT DETAIL	
CHANNEL	Channel 1	FREQUENCY RANGE	30MHz ~ 1GHz
INPUT POWER	120Vac, 60 Hz	DETECTOR FUNCTION	Peak (PK)
ENVIRONMENTAL CONDITIONS	25deg. C, 65%RH	TESTED BY	Gavin Wu

**ANTENNA POLARITY & TEST DISTANCE: HORIZONTAL AT 3 M**

FREQ. (MHz)	EMISSION LEVEL (dBuV/m)	READ LEVEL (dBuV)	LIMIT (dBuV/m)	MARGIN (dB)	ANTENNA FACTOR (dB/m)	CABLE LOSS (dB)	PREAMP FACTOR (dB)	ANTENNA HEIGHT (cm)	TABLE ANGLE (Degree)	REMARK
83.19	24.12	46.6	40	-15.88	8.18	0.99	31.65	139	24	Peak
126.12	27.49	46.74	43.5	-16.01	11.42	1.22	31.89	117	223	Peak
187.68	29.88	49.85	43.5	-13.62	10.19	1.54	31.7	112	40	Peak
316.8	21.59	38.03	46	-24.41	13.36	2.11	31.91	117	57	Peak
415.5	22.64	36.54	46	-23.36	15.64	2.48	32.02	105	25	Peak
521.9	22.59	33.51	46	-23.41	17.82	2.85	31.59	125	308	Peak

**ANTENNA POLARITY & TEST DISTANCE: VERTICAL AT 3 M**

FREQ. (MHz)	EMISSION LEVEL (dBuV/m)	READ LEVEL (dBuV)	LIMIT (dBuV/m)	MARGIN (dB)	ANTENNA FACTOR (dB/m)	CABLE LOSS (dB)	PREAMP FACTOR (dB)	ANTENNA HEIGHT (cm)	TABLE ANGLE (Degree)	REMARK
30.27	25.47	44.06	40	-14.53	11.98	0.57	31.14	103	139	Peak
83.19	33.53	56.01	40	-6.47	8.18	0.99	31.65	122	2	Peak
125.85	33.58	52.83	43.5	-9.92	11.42	1.22	31.89	137	271	Peak
316.8	19.04	35.48	46	-26.96	13.36	2.11	31.91	118	294	Peak
394.5	19.46	33.93	46	-26.54	15.21	2.4	32.08	102	336	Peak
514.9	22.83	33.92	46	-23.17	17.66	2.83	31.58	123	49	Peak

**REMARKS:** Emission Level = Read Level + Antenna Factor + Cable Loss - Preamp Factor  
 Margin value = Emission level – Limit value





A D T

EUT TEST CONDITION		MEASUREMENT DETAIL	
CHANNEL	Channel 6	FREQUENCY RANGE	30MHz ~ 1GHz
INPUT POWER	120Vac, 60 Hz	DETECTOR FUNCTION	Peak (PK)
ENVIRONMENTAL CONDITIONS	25deg. C, 65%RH	TESTED BY	Gavin Wu

**ANTENNA POLARITY & TEST DISTANCE: HORIZONTAL AT 3 M**

FREQ. (MHz)	EMISSION LEVEL (dBuV/m)	READ LEVEL (dBuV)	LIMIT (dBuV/m)	MARGIN (dB)	ANTENNA FACTOR (dB/m)	CABLE LOSS (dB)	PREAMP FACTOR (dB)	ANTENNA HEIGHT (cm)	TABLE ANGLE (Degree)	REMARK
83.19	22.65	45.13	40	-17.35	8.18	0.99	31.65	124	129	Peak
125.58	28.04	47.29	43.5	-15.46	11.42	1.22	31.89	107	226	Peak
193.35	28.95	49.25	43.5	-14.55	9.84	1.56	31.7	134	184	Peak
316.1	21.16	37.63	46	-24.84	13.33	2.11	31.91	103	33	Peak
436.5	21.59	34.97	46	-24.41	16.06	2.56	32	139	240	Peak
577.2	23.25	33.26	46	-22.75	19.08	3.02	32.11	130	243	Peak

**ANTENNA POLARITY & TEST DISTANCE: VERTICAL AT 3 M**

FREQ. (MHz)	EMISSION LEVEL (dBuV/m)	READ LEVEL (dBuV)	LIMIT (dBuV/m)	MARGIN (dB)	ANTENNA FACTOR (dB/m)	CABLE LOSS (dB)	PREAMP FACTOR (dB)	ANTENNA HEIGHT (cm)	TABLE ANGLE (Degree)	REMARK
31.08	25.62	44.03	40	-14.38	12.14	0.57	31.12	105	58	Peak
83.46	32.68	55.16	40	-7.32	8.18	0.99	31.65	130	258	Peak
126.12	34	53.25	43.5	-9.5	11.42	1.22	31.89	117	213	Peak
310.5	19.82	36.48	46	-26.18	13.2	2.09	31.95	140	190	Peak
444.9	20.6	33.76	46	-25.4	16.23	2.6	31.99	124	24	Peak
585.6	24.45	34.25	46	-21.55	19.28	3.05	32.13	137	159	Peak

**REMARKS:** Emission Level = Read Level + Antenna Factor + Cable Loss - Preamp Factor

Margin value = Emission level – Limit value



A D T

EUT TEST CONDITION		MEASUREMENT DETAIL	
CHANNEL	Channel 11	FREQUENCY RANGE	30MHz ~ 1GHz
INPUT POWER	120Vac, 60 Hz	DETECTOR FUNCTION	Peak (PK)
ENVIRONMENTAL CONDITIONS	25deg. C, 65%RH	TESTED BY	Gavin Wu

ANTENNA POLARITY & TEST DISTANCE: HORIZONTAL AT 3 M										
FREQ. (MHz)	EMISSION LEVEL (dBuV/m)	READ LEVEL (dBuV)	LIMIT (dBuV/m)	MARGIN (dB)	ANTENNA FACTOR (dB/m)	CABLE LOSS (dB)	PREAMP FACTOR (dB)	ANTENNA HEIGHT (cm)	TABLE ANGLE (Degree)	REMARK
83.46	22.17	44.65	40	-17.83	8.18	0.99	31.65	139	306	Peak
125.58	26.13	45.38	43.5	-17.37	11.42	1.22	31.89	101	338	Peak
188.76	28.45	48.48	43.5	-15.05	10.12	1.54	31.69	138	285	Peak
315.4	21.6	38.1	46	-24.4	13.31	2.11	31.92	110	158	Peak
415.5	22.29	36.19	46	-23.71	15.64	2.48	32.02	103	64	Peak
553.4	23.15	33.63	46	-22.85	18.55	2.96	31.99	106	253	Peak
ANTENNA POLARITY & TEST DISTANCE: VERTICAL AT 3 M										
FREQ. (MHz)	EMISSION LEVEL (dBuV/m)	READ LEVEL (dBuV)	LIMIT (dBuV/m)	MARGIN (dB)	ANTENNA FACTOR (dB/m)	CABLE LOSS (dB)	PREAMP FACTOR (dB)	ANTENNA HEIGHT (cm)	TABLE ANGLE (Degree)	REMARK
30.27	25.84	44.43	40	-14.16	11.98	0.57	31.14	113	296	Peak
83.19	33.6	56.08	40	-6.4	8.18	0.99	31.65	127	312	Peak
126.12	33.19	52.44	43.5	-10.31	11.42	1.22	31.89	113	22	Peak
349	18.42	33.92	46	-27.58	14.12	2.22	31.84	101	219	Peak
481.3	21.56	33.73	46	-24.44	16.95	2.72	31.84	125	83	Peak
605.9	24.31	33.67	46	-21.69	19.68	3.11	32.15	132	74	Peak

**REMARKS:** Emission Level = Read Level + Antenna Factor + Cable Loss - Preamp Factor  
Margin value = Emission level – Limit value



A D T

EUT TEST CONDITION		MEASUREMENT DETAIL	
CHANNEL	Channel 12	FREQUENCY RANGE	30MHz ~ 1GHz
INPUT POWER	120Vac, 60 Hz	DETECTOR FUNCTION	Peak (PK)
ENVIRONMENTAL CONDITIONS	25deg. C, 65%RH	TESTED BY	Gavin Wu

ANTENNA POLARITY & TEST DISTANCE: HORIZONTAL AT 3 M										
FREQ. (MHz)	EMISSION LEVEL (dBuV/m)	READ LEVEL (dBuV)	LIMIT (dBuV/m)	MARGIN (dB)	ANTENNA FACTOR (dB/m)	CABLE LOSS (dB)	PREAMP FACTOR (dB)	ANTENNA HEIGHT (cm)	TABLE ANGLE (Degree)	REMARK
82.38	20.49	42.95	40	-19.51	8.16	0.98	31.6	135	274	Peak
124.23	24.58	43.98	43.5	-18.92	11.28	1.21	31.89	128	260	Peak
193.89	27.02	47.4	43.5	-16.48	9.77	1.56	31.71	125	162	Peak
323.8	19.81	36.01	46	-26.19	13.52	2.14	31.86	128	117	Peak
501.6	21.42	32.91	46	-24.58	17.35	2.78	31.62	124	305	Peak
662.6	24.28	32.54	46	-21.72	20.36	3.29	31.91	124	347	Peak
ANTENNA POLARITY & TEST DISTANCE: VERTICAL AT 3 M										
FREQ. (MHz)	EMISSION LEVEL (dBuV/m)	READ LEVEL (dBuV)	LIMIT (dBuV/m)	MARGIN (dB)	ANTENNA FACTOR (dB/m)	CABLE LOSS (dB)	PREAMP FACTOR (dB)	ANTENNA HEIGHT (cm)	TABLE ANGLE (Degree)	REMARK
31.62	22.92	41.15	40	-17.08	12.3	0.58	31.11	119	352	Peak
83.73	32.4	54.88	40	-7.6	8.18	0.99	31.65	104	110	Peak
128.55	30.5	49.54	43.5	-13	11.61	1.23	31.88	104	97	Peak
380.5	17.59	32.32	46	-28.41	14.87	2.35	31.95	138	49	Peak
540.1	21.14	31.71	46	-24.86	18.24	2.92	31.73	101	157	Peak
674.5	24.38	32.37	46	-21.62	20.5	3.33	31.82	115	161	Peak

**REMARKS:** Emission Level = Read Level + Antenna Factor + Cable Loss - Preamp Factor  
Margin value = Emission level – Limit value



A D T

EUT TEST CONDITION		MEASUREMENT DETAIL	
CHANNEL	Channel 13	FREQUENCY RANGE	30MHz ~ 1GHz
INPUT POWER	120Vac, 60 Hz	DETECTOR FUNCTION	Peak (PK)
ENVIRONMENTAL CONDITIONS	25deg. C, 65%RH	TESTED BY	Gavin Wu

ANTENNA POLARITY & TEST DISTANCE: HORIZONTAL AT 3 M										
FREQ. (MHz)	EMISSION LEVEL (dBuV/m)	READ LEVEL (dBuV)	LIMIT (dBuV/m)	MARGIN (dB)	ANTENNA FACTOR (dB/m)	CABLE LOSS (dB)	PREAMP FACTOR (dB)	ANTENNA HEIGHT (cm)	TABLE ANGLE (Degree)	REMARK
84	22.49	44.99	40	-17.51	8.2	0.99	31.69	132	247	Peak
124.23	25.75	45.15	43.5	-17.75	11.28	1.21	31.89	117	236	Peak
208.2	27.95	48.21	43.5	-15.55	9.73	1.63	31.62	102	263	Peak
327.3	19.04	35.13	46	-26.96	13.59	2.15	31.83	120	200	Peak
474.3	20.31	32.67	46	-25.69	16.81	2.7	31.87	121	37	Peak
638.1	22.53	31.36	46	-23.47	20.07	3.2	32.1	124	262	Peak

ANTENNA POLARITY & TEST DISTANCE: VERTICAL AT 3 M										
FREQ. (MHz)	EMISSION LEVEL (dBuV/m)	READ LEVEL (dBuV)	LIMIT (dBuV/m)	MARGIN (dB)	ANTENNA FACTOR (dB/m)	CABLE LOSS (dB)	PREAMP FACTOR (dB)	ANTENNA HEIGHT (cm)	TABLE ANGLE (Degree)	REMARK
31.35	23.77	42.18	40	-16.23	12.14	0.57	31.12	115	93	Peak
83.73	32.1	54.58	40	-7.9	8.18	0.99	31.65	104	243	Peak
128.28	32.13	51.23	43.5	-11.37	11.55	1.23	31.88	129	184	Peak
335.7	16.6	32.44	46	-29.4	13.8	2.18	31.82	104	196	Peak
448.4	19.58	32.66	46	-26.42	16.29	2.61	31.98	115	204	Peak
666.1	24.29	32.44	46	-21.71	20.41	3.3	31.86	112	324	Peak

**REMARKS:** Emission Level = Read Level + Antenna Factor + Cable Loss - Preamp Factor  
 Margin value = Emission level – Limit value



A D T

802.11n (20MHz)

EUT TEST CONDITION		MEASUREMENT DETAIL	
CHANNEL	Channel 1	FREQUENCY RANGE	30MHz ~ 1GHz
INPUT POWER	120Vac, 60 Hz	DETECTOR FUNCTION	Peak (PK)
ENVIRONMENTAL CONDITIONS	25deg. C, 65%RH	TESTED BY	Gavin Wu

ANTENNA POLARITY & TEST DISTANCE: HORIZONTAL AT 3 M

FREQ. (MHz)	EMISSION LEVEL (dBuV/m)	READ LEVEL (dBuV)	LIMIT (dBuV/m)	MARGIN (dB)	ANTENNA FACTOR (dB/m)	CABLE LOSS (dB)	PREAMP FACTOR (dB)	ANTENNA HEIGHT (cm)	TABLE ANGLE (Degree)	REMARK
83.19	22.53	45.01	40	-17.47	8.18	0.99	31.65	128	46	Peak
126.12	27.47	46.72	43.5	-16.03	11.42	1.22	31.89	136	217	Peak
192.54	29.01	49.31	43.5	-14.49	9.84	1.56	31.7	136	252	Peak
320.3	21.46	37.8	46	-24.54	13.43	2.12	31.89	100	343	Peak
436.5	20.66	34.04	46	-25.34	16.06	2.56	32	113	180	Peak
584.9	22.96	32.79	46	-23.04	19.26	3.04	32.13	119	104	Peak

ANTENNA POLARITY & TEST DISTANCE: VERTICAL AT 3 M

FREQ. (MHz)	EMISSION LEVEL (dBuV/m)	READ LEVEL (dBuV)	LIMIT (dBuV/m)	MARGIN (dB)	ANTENNA FACTOR (dB/m)	CABLE LOSS (dB)	PREAMP FACTOR (dB)	ANTENNA HEIGHT (cm)	TABLE ANGLE (Degree)	REMARK
30.27	26.24	44.83	40	-13.76	11.98	0.57	31.14	131	144	Peak
82.92	33.27	55.75	40	-6.73	8.18	0.99	31.65	133	225	Peak
125.85	33.23	52.48	43.5	-10.27	11.42	1.22	31.89	120	122	Peak
341.3	18.7	34.38	46	-27.3	13.94	2.2	31.82	123	332	Peak
457.5	20.97	33.84	46	-25.03	16.48	2.64	31.99	115	353	Peak
628.3	24.18	33.21	46	-21.82	19.95	3.17	32.15	108	130	Peak

REMARKS: Emission Level = Read Level + Antenna Factor + Cable Loss - Preamp Factor  
 Margin value = Emission level – Limit value



A D T

EUT TEST CONDITION		MEASUREMENT DETAIL	
CHANNEL	Channel 6	FREQUENCY RANGE	30MHz ~ 1GHz
INPUT POWER	120Vac, 60 Hz	DETECTOR FUNCTION	Peak (PK)
ENVIRONMENTAL CONDITIONS	25deg. C, 65%RH	TESTED BY	Gavin Wu

ANTENNA POLARITY & TEST DISTANCE: HORIZONTAL AT 3 M										
FREQ. (MHz)	EMISSION LEVEL (dBuV/m)	READ LEVEL (dBuV)	LIMIT (dBuV/m)	MARGIN (dB)	ANTENNA FACTOR (dB/m)	CABLE LOSS (dB)	PREAMP FACTOR (dB)	ANTENNA HEIGHT (cm)	TABLE ANGLE (Degree)	REMARK
83.46	22.52	45	40	-17.48	8.18	0.99	31.65	125	301	Peak
125.31	27.72	47.05	43.5	-15.78	11.35	1.21	31.89	129	136	Peak
187.14	29.21	49.14	43.5	-14.29	10.26	1.53	31.72	131	149	Peak
311.9	21.61	38.21	46	-24.39	13.24	2.1	31.94	117	238	Peak
458.2	22.51	35.38	46	-23.49	16.48	2.64	31.99	110	12	Peak
574.4	23.17	33.24	46	-22.83	19.01	3.02	32.1	125	31	Peak

ANTENNA POLARITY & TEST DISTANCE: VERTICAL AT 3 M										
FREQ. (MHz)	EMISSION LEVEL (dBuV/m)	READ LEVEL (dBuV)	LIMIT (dBuV/m)	MARGIN (dB)	ANTENNA FACTOR (dB/m)	CABLE LOSS (dB)	PREAMP FACTOR (dB)	ANTENNA HEIGHT (cm)	TABLE ANGLE (Degree)	REMARK
30.81	26.45	44.86	40	-13.55	12.14	0.57	31.12	103	351	Peak
82.92	33.13	55.61	40	-6.87	8.18	0.99	31.65	114	31	Peak
126.12	33.04	52.29	43.5	-10.46	11.42	1.22	31.89	133	280	Peak
313.3	18.37	34.94	46	-27.63	13.26	2.1	31.93	138	184	Peak
461.7	21.16	33.92	46	-24.84	16.56	2.65	31.97	111	332	Peak
585.6	25.24	35.04	46	-20.76	19.28	3.05	32.13	109	114	Peak

**REMARKS:** Emission Level = Read Level + Antenna Factor + Cable Loss - Preamp Factor  
 Margin value = Emission level – Limit value



A D T

EUT TEST CONDITION		MEASUREMENT DETAIL	
CHANNEL	Channel 11	FREQUENCY RANGE	30MHz ~ 1GHz
INPUT POWER	120Vac, 60 Hz	DETECTOR FUNCTION	Peak (PK)
ENVIRONMENTAL CONDITIONS	25deg. C, 65%RH	TESTED BY	Gavin Wu

ANTENNA POLARITY & TEST DISTANCE: HORIZONTAL AT 3 M										
FREQ. (MHz)	EMISSION LEVEL (dBuV/m)	READ LEVEL (dBuV)	LIMIT (dBuV/m)	MARGIN (dB)	ANTENNA FACTOR (dB/m)	CABLE LOSS (dB)	PREAMP FACTOR (dB)	ANTENNA HEIGHT (cm)	TABLE ANGLE (Degree)	REMARK
83.19	21.96	44.44	40	-18.04	8.18	0.99	31.65	118	106	Peak
126.66	26.35	45.54	43.5	-17.15	11.48	1.22	31.89	100	212	Peak
186.87	28.44	48.37	43.5	-15.06	10.26	1.53	31.72	121	146	Peak
318.2	20.79	37.19	46	-25.21	13.38	2.12	31.9	124	288	Peak
415.5	21.8	35.7	46	-24.2	15.64	2.48	32.02	105	350	Peak
526.8	22.46	33.31	46	-23.54	17.93	2.87	31.65	115	289	Peak
ANTENNA POLARITY & TEST DISTANCE: VERTICAL AT 3 M										
FREQ. (MHz)	EMISSION LEVEL (dBuV/m)	READ LEVEL (dBuV)	LIMIT (dBuV/m)	MARGIN (dB)	ANTENNA FACTOR (dB/m)	CABLE LOSS (dB)	PREAMP FACTOR (dB)	ANTENNA HEIGHT (cm)	TABLE ANGLE (Degree)	REMARK
30.81	26.1	44.51	40	-13.9	12.14	0.57	31.12	104	53	Peak
83.46	32.9	55.38	40	-7.1	8.18	0.99	31.65	101	211	Peak
125.85	33.05	52.3	43.5	-10.45	11.42	1.22	31.89	129	337	Peak
314.7	17.56	34.06	46	-28.44	13.31	2.11	31.92	137	289	Peak
457.5	21.04	33.91	46	-24.96	16.48	2.64	31.99	127	88	Peak
584.9	24.03	33.86	46	-21.97	19.26	3.04	32.13	126	212	Peak

**REMARKS:** Emission Level = Read Level + Antenna Factor + Cable Loss - Preamp Factor  
 Margin value = Emission level – Limit value



A D T

EUT TEST CONDITION		MEASUREMENT DETAIL	
CHANNEL	Channel 12	FREQUENCY RANGE	30MHz ~ 1GHz
INPUT POWER	120Vac, 60 Hz	DETECTOR FUNCTION	Peak (PK)
ENVIRONMENTAL CONDITIONS	25deg. C, 65%RH	TESTED BY	Gavin Wu

ANTENNA POLARITY & TEST DISTANCE: HORIZONTAL AT 3 M										
FREQ. (MHz)	EMISSION LEVEL (dBuV/m)	READ LEVEL (dBuV)	LIMIT (dBuV/m)	MARGIN (dB)	ANTENNA FACTOR (dB/m)	CABLE LOSS (dB)	PREAMP FACTOR (dB)	ANTENNA HEIGHT (cm)	TABLE ANGLE (Degree)	REMARK
84.27	20.2	42.7	40	-19.8	8.2	0.99	31.69	140	164	Peak
128.01	26.88	45.98	43.5	-16.62	11.55	1.23	31.88	118	306	Peak
204.15	26.17	46.68	43.5	-17.33	9.56	1.62	31.69	126	172	Peak
333.6	17.93	33.82	46	-28.07	13.75	2.17	31.81	135	286	Peak
510	20.23	31.46	46	-25.77	17.55	2.81	31.59	112	213	Peak
662.6	23.16	31.42	46	-22.84	20.36	3.29	31.91	127	317	Peak

ANTENNA POLARITY & TEST DISTANCE: VERTICAL AT 3 M										
FREQ. (MHz)	EMISSION LEVEL (dBuV/m)	READ LEVEL (dBuV)	LIMIT (dBuV/m)	MARGIN (dB)	ANTENNA FACTOR (dB/m)	CABLE LOSS (dB)	PREAMP FACTOR (dB)	ANTENNA HEIGHT (cm)	TABLE ANGLE (Degree)	REMARK
31.89	22.91	41.14	40	-17.09	12.3	0.58	31.11	105	136	Peak
78.87	29.94	51.94	40	-10.06	8.61	0.96	31.57	127	340	Peak
128.28	31.38	50.48	43.5	-12.12	11.55	1.23	31.88	138	94	Peak
358.8	17.92	33.26	46	-28.08	14.36	2.26	31.96	113	82	Peak
510.7	21.63	32.83	46	-24.37	17.57	2.82	31.59	128	135	Peak
647.9	24.01	32.62	46	-21.99	20.19	3.23	32.03	140	163	Peak

**REMARKS:** Emission Level = Read Level + Antenna Factor + Cable Loss - Preamp Factor  
 Margin value = Emission level – Limit value





A D T

EUT TEST CONDITION		MEASUREMENT DETAIL	
CHANNEL	Channel 13	FREQUENCY RANGE	30MHz ~ 1GHz
INPUT POWER	120Vac, 60 Hz	DETECTOR FUNCTION	Peak (PK)
ENVIRONMENTAL CONDITIONS	25deg. C, 65%RH	TESTED BY	Gavin Wu

ANTENNA POLARITY & TEST DISTANCE: HORIZONTAL AT 3 M										
FREQ. (MHz)	EMISSION LEVEL (dBuV/m)	READ LEVEL (dBuV)	LIMIT (dBuV/m)	MARGIN (dB)	ANTENNA FACTOR (dB/m)	CABLE LOSS (dB)	PREAMP FACTOR (dB)	ANTENNA HEIGHT (cm)	TABLE ANGLE (Degree)	REMARK
84	20.01	42.51	40	-19.99	8.2	0.99	31.69	130	252	Peak
124.5	23.29	42.69	43.5	-20.21	11.28	1.21	31.89	100	180	Peak
183.36	25.5	45.25	43.5	-18	10.53	1.51	31.79	128	59	Peak
307	18.9	35.61	46	-27.1	13.13	2.08	31.92	101	181	Peak
446.3	19.07	32.21	46	-26.93	16.25	2.6	31.99	127	218	Peak
620.6	22.63	31.79	46	-23.37	19.86	3.15	32.17	140	79	Peak
ANTENNA POLARITY & TEST DISTANCE: VERTICAL AT 3 M										
FREQ. (MHz)	EMISSION LEVEL (dBuV/m)	READ LEVEL (dBuV)	LIMIT (dBuV/m)	MARGIN (dB)	ANTENNA FACTOR (dB/m)	CABLE LOSS (dB)	PREAMP FACTOR (dB)	ANTENNA HEIGHT (cm)	TABLE ANGLE (Degree)	REMARK
31.62	23.93	42.16	40	-16.07	12.3	0.58	31.11	129	316	Peak
82.38	30.91	53.37	40	-9.09	8.16	0.98	31.6	127	22	Peak
127.74	31.58	50.68	43.5	-11.92	11.55	1.23	31.88	109	106	Peak
363.7	16.15	31.35	46	-29.85	14.47	2.28	31.95	123	257	Peak
527.5	20.69	31.54	46	-25.31	17.95	2.87	31.67	112	261	Peak
680.8	24.07	31.96	46	-21.93	20.59	3.36	31.84	110	206	Peak

**REMARKS:** Emission Level = Read Level + Antenna Factor + Cable Loss - Preamp Factor  
 Margin value = Emission level – Limit value



A D T

**Mode B**

**802.11b**

EUT TEST CONDITION		MEASUREMENT DETAIL	
CHANNEL	Channel 1	FREQUENCY RANGE	30MHz ~ 1GHz
INPUT POWER	120Vac, 60 Hz	DETECTOR FUNCTION	Peak (PK)
ENVIRONMENTAL CONDITIONS	25deg. C, 65%RH	TESTED BY	Gavin Wu

**ANTENNA POLARITY & TEST DISTANCE: HORIZONTAL AT 3 M**

FREQ. (MHz)	EMISSION LEVEL (dBuV/m)	READ LEVEL (dBuV)	LIMIT (dBuV/m)	MARGIN (dB)	ANTENNA FACTOR (dB/m)	CABLE LOSS (dB)	PREAMP FACTOR (dB)	ANTENNA HEIGHT (cm)	TABLE ANGLE (Degree)	REMARK
82.92	21.05	43.53	40	-18.95	8.18	0.99	31.65	132	295	Peak
125.85	27.2	46.45	43.5	-16.3	11.42	1.22	31.89	108	244	Peak
192.54	29.44	49.74	43.5	-14.06	9.84	1.56	31.7	129	288	Peak
318.2	22.19	38.59	46	-23.81	13.38	2.12	31.9	132	177	Peak
477.8	21.46	33.72	46	-24.54	16.89	2.71	31.86	116	231	Peak
601.7	23.97	33.49	46	-22.03	19.62	3.09	32.23	124	285	Peak

**ANTENNA POLARITY & TEST DISTANCE: VERTICAL AT 3 M**

FREQ. (MHz)	EMISSION LEVEL (dBuV/m)	READ LEVEL (dBuV)	LIMIT (dBuV/m)	MARGIN (dB)	ANTENNA FACTOR (dB/m)	CABLE LOSS (dB)	PREAMP FACTOR (dB)	ANTENNA HEIGHT (cm)	TABLE ANGLE (Degree)	REMARK
30.81	25.98	44.39	40	-14.02	12.14	0.57	31.12	136	220	Peak
82.38	31.59	54.05	40	-8.41	8.16	0.98	31.6	100	338	Peak
125.58	31.88	51.13	43.5	-11.62	11.42	1.22	31.89	137	194	Peak
300	18.02	34.87	46	-27.98	12.94	2.05	31.84	120	259	Peak
396.6	19.4	33.83	46	-26.6	15.26	2.41	32.1	100	100	Peak
500.9	22.61	34.12	46	-23.39	17.33	2.78	31.62	107	327	Peak

**REMARKS:** Emission Level = Read Level + Antenna Factor + Cable Loss - Preamp Factor

Margin value = Emission level – Limit value



A D T

EUT TEST CONDITION		MEASUREMENT DETAIL	
CHANNEL	Channel 6	FREQUENCY RANGE	30MHz ~ 1GHz
INPUT POWER	120Vac, 60 Hz	DETECTOR FUNCTION	Peak (PK)
ENVIRONMENTAL CONDITIONS	25deg. C, 65%RH	TESTED BY	Gavin Wu

ANTENNA POLARITY & TEST DISTANCE: HORIZONTAL AT 3 M										
FREQ. (MHz)	EMISSION LEVEL (dBuV/m)	READ LEVEL (dBuV)	LIMIT (dBuV/m)	MARGIN (dB)	ANTENNA FACTOR (dB/m)	CABLE LOSS (dB)	PREAMP FACTOR (dB)	ANTENNA HEIGHT (cm)	TABLE ANGLE (Degree)	REMARK
82.11	20.7	43.16	40	-19.3	8.16	0.98	31.6	116	243	Peak
126.12	26.94	46.19	43.5	-16.56	11.42	1.22	31.89	114	350	Peak
193.62	29.22	49.6	43.5	-14.28	9.77	1.56	31.71	126	166	Peak
312.6	21.62	38.22	46	-24.38	13.24	2.1	31.94	101	157	Peak
458.2	21.3	34.17	46	-24.7	16.48	2.64	31.99	109	60	Peak
624.8	24.53	33.63	46	-21.47	19.9	3.16	32.16	133	109	Peak

ANTENNA POLARITY & TEST DISTANCE: VERTICAL AT 3 M										
FREQ. (MHz)	EMISSION LEVEL (dBuV/m)	READ LEVEL (dBuV)	LIMIT (dBuV/m)	MARGIN (dB)	ANTENNA FACTOR (dB/m)	CABLE LOSS (dB)	PREAMP FACTOR (dB)	ANTENNA HEIGHT (cm)	TABLE ANGLE (Degree)	REMARK
30.81	25.82	44.23	40	-14.18	12.14	0.57	31.12	108	330	Peak
79.68	29.02	51.22	40	-10.98	8.37	0.97	31.54	101	272	Peak
125.85	29.59	48.84	43.5	-13.91	11.42	1.22	31.89	107	70	Peak
340.6	17.56	33.28	46	-28.44	13.91	2.19	31.82	136	202	Peak
436.5	21.15	34.53	46	-24.85	16.06	2.56	32	114	251	Peak
585.6	24.95	34.75	46	-21.05	19.28	3.05	32.13	104	299	Peak

**REMARKS:** Emission Level = Read Level + Antenna Factor + Cable Loss - Preamp Factor

Margin value = Emission level – Limit value



A D T

EUT TEST CONDITION		MEASUREMENT DETAIL	
CHANNEL	Channel 11	FREQUENCY RANGE	30MHz ~ 1GHz
INPUT POWER	120Vac, 60 Hz	DETECTOR FUNCTION	Peak (PK)
ENVIRONMENTAL CONDITIONS	25deg. C, 65%RH	TESTED BY	Gavin Wu

ANTENNA POLARITY & TEST DISTANCE: HORIZONTAL AT 3 M										
FREQ. (MHz)	EMISSION LEVEL (dBuV/m)	READ LEVEL (dBuV)	LIMIT (dBuV/m)	MARGIN (dB)	ANTENNA FACTOR (dB/m)	CABLE LOSS (dB)	PREAMP FACTOR (dB)	ANTENNA HEIGHT (cm)	TABLE ANGLE (Degree)	REMARK
82.92	20.82	43.3	40	-19.18	8.18	0.99	31.65	112	316	Peak
125.04	26.79	46.12	43.5	-16.71	11.35	1.21	31.89	128	132	Peak
192.54	29.32	49.62	43.5	-14.18	9.84	1.56	31.7	105	230	Peak
312.6	21.83	38.43	46	-24.17	13.24	2.1	31.94	104	296	Peak
458.2	22.4	35.27	46	-23.6	16.48	2.64	31.99	105	79	Peak
618.5	24.62	33.81	46	-21.38	19.83	3.14	32.16	116	174	Peak

ANTENNA POLARITY & TEST DISTANCE: VERTICAL AT 3 M										
FREQ. (MHz)	EMISSION LEVEL (dBuV/m)	READ LEVEL (dBuV)	LIMIT (dBuV/m)	MARGIN (dB)	ANTENNA FACTOR (dB/m)	CABLE LOSS (dB)	PREAMP FACTOR (dB)	ANTENNA HEIGHT (cm)	TABLE ANGLE (Degree)	REMARK
30.81	26.3	44.71	40	-13.7	12.14	0.57	31.12	106	155	Peak
82.92	30.39	52.87	40	-9.61	8.18	0.99	31.65	136	150	Peak
125.04	29.75	49.08	43.5	-13.75	11.35	1.21	31.89	111	145	Peak
310.5	18.41	35.07	46	-27.59	13.2	2.09	31.95	117	259	Peak
436.5	20.38	33.76	46	-25.62	16.06	2.56	32	108	111	Peak
564.6	23.18	33.47	46	-22.82	18.79	2.99	32.07	110	159	Peak

**REMARKS:** Emission Level = Read Level + Antenna Factor + Cable Loss - Preamp Factor  
 Margin value = Emission level – Limit value



A D T

EUT TEST CONDITION		MEASUREMENT DETAIL	
CHANNEL	Channel 12	FREQUENCY RANGE	30MHz ~ 1GHz
INPUT POWER	120Vac, 60 Hz	DETECTOR FUNCTION	Peak (PK)
ENVIRONMENTAL CONDITIONS	25deg. C, 65%RH	TESTED BY	Gavin Wu

ANTENNA POLARITY & TEST DISTANCE: HORIZONTAL AT 3 M										
FREQ. (MHz)	EMISSION LEVEL (dBuV/m)	READ LEVEL (dBuV)	LIMIT (dBuV/m)	MARGIN (dB)	ANTENNA FACTOR (dB/m)	CABLE LOSS (dB)	PREAMP FACTOR (dB)	ANTENNA HEIGHT (cm)	TABLE ANGLE (Degree)	REMARK
83.73	19.24	41.72	40	-20.76	8.18	0.99	31.65	122	7	Peak
128.28	25.23	44.33	43.5	-18.27	11.55	1.23	31.88	123	83	Peak
185.25	26.28	46.13	43.5	-17.22	10.39	1.52	31.76	129	100	Peak
316.8	19.97	36.41	46	-26.03	13.36	2.11	31.91	104	344	Peak
507.2	21.61	32.93	46	-24.39	17.48	2.8	31.6	114	306	Peak
652.8	23.13	31.64	46	-22.87	20.24	3.25	32	137	143	Peak
ANTENNA POLARITY & TEST DISTANCE: VERTICAL AT 3 M										
FREQ. (MHz)	EMISSION LEVEL (dBuV/m)	READ LEVEL (dBuV)	LIMIT (dBuV/m)	MARGIN (dB)	ANTENNA FACTOR (dB/m)	CABLE LOSS (dB)	PREAMP FACTOR (dB)	ANTENNA HEIGHT (cm)	TABLE ANGLE (Degree)	REMARK
31.89	22.17	40.4	40	-17.83	12.3	0.58	31.11	134	145	Peak
81.57	27.21	49.64	40	-12.79	8.15	0.98	31.56	138	321	Peak
128.82	27.32	46.36	43.5	-16.18	11.61	1.23	31.88	126	160	Peak
358.1	16.75	32.1	46	-29.25	14.33	2.26	31.94	112	356	Peak
497.4	20.71	32.33	46	-25.29	17.27	2.77	31.66	139	220	Peak
675.9	24.23	32.19	46	-21.77	20.53	3.34	31.83	107	7	Peak

**REMARKS:** Emission Level = Read Level + Antenna Factor + Cable Loss - Preamp Factor  
Margin value = Emission level – Limit value



A D T

EUT TEST CONDITION		MEASUREMENT DETAIL	
CHANNEL	Channel 13	FREQUENCY RANGE	30MHz ~ 1GHz
INPUT POWER	120Vac, 60 Hz	DETECTOR FUNCTION	Peak (PK)
ENVIRONMENTAL CONDITIONS	25deg. C, 65%RH	TESTED BY	Gavin Wu

ANTENNA POLARITY & TEST DISTANCE: HORIZONTAL AT 3 M										
FREQ. (MHz)	EMISSION LEVEL (dBuV/m)	READ LEVEL (dBuV)	LIMIT (dBuV/m)	MARGIN (dB)	ANTENNA FACTOR (dB/m)	CABLE LOSS (dB)	PREAMP FACTOR (dB)	ANTENNA HEIGHT (cm)	TABLE ANGLE (Degree)	REMARK
81.57	18.2	40.63	40	-21.8	8.15	0.98	31.56	105	120	Peak
128.55	24.8	43.84	43.5	-18.7	11.61	1.23	31.88	119	137	Peak
185.52	27.25	47.1	43.5	-16.25	10.39	1.52	31.76	107	352	Peak
326.6	19.24	35.33	46	-26.76	13.59	2.15	31.83	105	64	Peak
527.5	21.56	32.41	46	-24.44	17.95	2.87	31.67	130	114	Peak
679.4	24.35	32.28	46	-21.65	20.56	3.35	31.84	133	79	Peak

ANTENNA POLARITY & TEST DISTANCE: VERTICAL AT 3 M										
FREQ. (MHz)	EMISSION LEVEL (dBuV/m)	READ LEVEL (dBuV)	LIMIT (dBuV/m)	MARGIN (dB)	ANTENNA FACTOR (dB/m)	CABLE LOSS (dB)	PREAMP FACTOR (dB)	ANTENNA HEIGHT (cm)	TABLE ANGLE (Degree)	REMARK
31.89	22.37	40.6	40	-17.63	12.3	0.58	31.11	119	282	Peak
83.73	27.69	50.17	40	-12.31	8.18	0.99	31.65	132	118	Peak
128.55	27.86	46.9	43.5	-15.64	11.61	1.23	31.88	135	169	Peak
349.7	16.49	31.95	46	-29.51	14.15	2.23	31.84	114	303	Peak
507.2	20.25	31.57	46	-25.75	17.48	2.8	31.6	128	3	Peak
653.5	23.09	31.56	46	-22.91	20.26	3.26	31.99	122	179	Peak

**REMARKS:** Emission Level = Read Level + Antenna Factor + Cable Loss - Preamp Factor  
 Margin value = Emission level – Limit value



A D T

802.11g

EUT TEST CONDITION		MEASUREMENT DETAIL	
CHANNEL	Channel 1	FREQUENCY RANGE	30MHz ~ 1GHz
INPUT POWER	120Vac, 60 Hz	DETECTOR FUNCTION	Peak (PK)
ENVIRONMENTAL CONDITIONS	25deg. C, 65%RH	TESTED BY	Gavin Wu

**ANTENNA POLARITY & TEST DISTANCE: HORIZONTAL AT 3 M**

FREQ. (MHz)	EMISSION LEVEL (dBuV/m)	READ LEVEL (dBuV)	LIMIT (dBuV/m)	MARGIN (dB)	ANTENNA FACTOR (dB/m)	CABLE LOSS (dB)	PREAMP FACTOR (dB)	ANTENNA HEIGHT (cm)	TABLE ANGLE (Degree)	REMARK
83.19	20.71	43.19	40	-19.29	8.18	0.99	31.65	135	196	Peak
127.2	26.71	45.9	43.5	-16.79	11.48	1.22	31.89	130	96	Peak
188.22	29.52	49.49	43.5	-13.98	10.19	1.54	31.7	136	287	Peak
315.4	21.97	38.47	46	-24.03	13.31	2.11	31.92	122	168	Peak
445.6	20.33	33.49	46	-25.67	16.23	2.6	31.99	109	89	Peak
608.7	24.2	33.46	46	-21.8	19.72	3.12	32.1	114	94	Peak

**ANTENNA POLARITY & TEST DISTANCE: VERTICAL AT 3 M**

FREQ. (MHz)	EMISSION LEVEL (dBuV/m)	READ LEVEL (dBuV)	LIMIT (dBuV/m)	MARGIN (dB)	ANTENNA FACTOR (dB/m)	CABLE LOSS (dB)	PREAMP FACTOR (dB)	ANTENNA HEIGHT (cm)	TABLE ANGLE (Degree)	REMARK
30.81	25.9	44.31	40	-14.1	12.14	0.57	31.12	119	306	Peak
82.92	29.85	52.33	40	-10.15	8.18	0.99	31.65	108	24	Peak
126.12	29.85	49.1	43.5	-13.65	11.42	1.22	31.89	107	294	Peak
363	17.9	33.13	46	-28.1	14.45	2.28	31.96	126	351	Peak
458.2	23.09	35.96	46	-22.91	16.48	2.64	31.99	118	200	Peak
584.9	24.45	34.28	46	-21.55	19.26	3.04	32.13	127	35	Peak

**REMARKS:** Emission Level = Read Level + Antenna Factor + Cable Loss - Preamp Factor  
 Margin value = Emission level – Limit value



A D T

EUT TEST CONDITION		MEASUREMENT DETAIL	
CHANNEL	Channel 6	FREQUENCY RANGE	30MHz ~ 1GHz
INPUT POWER	120Vac, 60 Hz	DETECTOR FUNCTION	Peak (PK)
ENVIRONMENTAL CONDITIONS	25deg. C, 65%RH	TESTED BY	Gavin Wu

ANTENNA POLARITY & TEST DISTANCE: HORIZONTAL AT 3 M										
FREQ. (MHz)	EMISSION LEVEL (dBuV/m)	READ LEVEL (dBuV)	LIMIT (dBuV/m)	MARGIN (dB)	ANTENNA FACTOR (dB/m)	CABLE LOSS (dB)	PREAMP FACTOR (dB)	ANTENNA HEIGHT (cm)	TABLE ANGLE (Degree)	REMARK
82.92	20.98	43.46	40	-19.02	8.18	0.99	31.65	100	317	Peak
125.31	26.04	45.37	43.5	-17.46	11.35	1.21	31.89	125	222	Peak
192.27	29.52	49.74	43.5	-13.98	9.91	1.56	31.69	115	128	Peak
309.1	21.76	38.45	46	-24.24	13.17	2.08	31.94	128	142	Peak
393.8	21.38	35.87	46	-24.62	15.19	2.4	32.08	125	270	Peak
591.9	23.84	33.53	46	-22.16	19.41	3.06	32.16	106	150	Peak
ANTENNA POLARITY & TEST DISTANCE: VERTICAL AT 3 M										
FREQ. (MHz)	EMISSION LEVEL (dBuV/m)	READ LEVEL (dBuV)	LIMIT (dBuV/m)	MARGIN (dB)	ANTENNA FACTOR (dB/m)	CABLE LOSS (dB)	PREAMP FACTOR (dB)	ANTENNA HEIGHT (cm)	TABLE ANGLE (Degree)	REMARK
31.08	25.86	44.27	40	-14.14	12.14	0.57	31.12	140	182	Peak
82.92	31.49	53.97	40	-8.51	8.18	0.99	31.65	115	335	Peak
126.12	30.96	50.21	43.5	-12.54	11.42	1.22	31.89	139	308	Peak
377	18.24	33.05	46	-27.76	14.8	2.33	31.94	132	69	Peak
479.9	22.31	34.52	46	-23.69	16.93	2.71	31.85	138	223	Peak
554.1	23.05	33.53	46	-22.95	18.55	2.96	31.99	112	120	Peak

**REMARKS:** Emission Level = Read Level + Antenna Factor + Cable Loss - Preamp Factor  
 Margin value = Emission level – Limit value





A D T

EUT TEST CONDITION		MEASUREMENT DETAIL	
CHANNEL	Channel 11	FREQUENCY RANGE	30MHz ~ 1GHz
INPUT POWER	120Vac, 60 Hz	DETECTOR FUNCTION	Peak (PK)
ENVIRONMENTAL CONDITIONS	25deg. C, 65%RH	TESTED BY	Gavin Wu

**ANTENNA POLARITY & TEST DISTANCE: HORIZONTAL AT 3 M**

FREQ. (MHz)	EMISSION LEVEL (dBuV/m)	READ LEVEL (dBuV)	LIMIT (dBuV/m)	MARGIN (dB)	ANTENNA FACTOR (dB/m)	CABLE LOSS (dB)	PREAMP FACTOR (dB)	ANTENNA HEIGHT (cm)	TABLE ANGLE (Degree)	REMARK
83.19	20.75	43.23	40	-19.25	8.18	0.99	31.65	117	346	Peak
126.39	25.86	45.11	43.5	-17.64	11.42	1.22	31.89	125	128	Peak
193.35	28.92	49.22	43.5	-14.58	9.84	1.56	31.7	121	52	Peak
315.4	21.36	37.86	46	-24.64	13.31	2.11	31.92	114	82	Peak
458.2	22.63	35.5	46	-23.37	16.48	2.64	31.99	123	345	Peak
582.8	24.29	34.17	46	-21.71	19.21	3.04	32.13	121	55	Peak

**ANTENNA POLARITY & TEST DISTANCE: VERTICAL AT 3 M**

FREQ. (MHz)	EMISSION LEVEL (dBuV/m)	READ LEVEL (dBuV)	LIMIT (dBuV/m)	MARGIN (dB)	ANTENNA FACTOR (dB/m)	CABLE LOSS (dB)	PREAMP FACTOR (dB)	ANTENNA HEIGHT (cm)	TABLE ANGLE (Degree)	REMARK
30.81	26.97	45.38	40	-13.03	12.14	0.57	31.12	132	100	Peak
83.19	31.27	53.75	40	-8.73	8.18	0.99	31.65	101	1	Peak
126.12	31.53	50.78	43.5	-11.97	11.42	1.22	31.89	104	42	Peak
347.6	17.49	33.02	46	-28.51	14.08	2.22	31.83	140	69	Peak
458.2	20.68	33.55	46	-25.32	16.48	2.64	31.99	134	139	Peak
589.8	25.4	35.11	46	-20.6	19.37	3.06	32.14	101	297	Peak

**REMARKS:** Emission Level = Read Level + Antenna Factor + Cable Loss - Preamp Factor

Margin value = Emission level – Limit value



A D T

EUT TEST CONDITION		MEASUREMENT DETAIL	
CHANNEL	Channel 12	FREQUENCY RANGE	30MHz ~ 1GHz
INPUT POWER	120Vac, 60 Hz	DETECTOR FUNCTION	Peak (PK)
ENVIRONMENTAL CONDITIONS	25deg. C, 65%RH	TESTED BY	Gavin Wu

ANTENNA POLARITY & TEST DISTANCE: HORIZONTAL AT 3 M										
FREQ. (MHz)	EMISSION LEVEL (dBuV/m)	READ LEVEL (dBuV)	LIMIT (dBuV/m)	MARGIN (dB)	ANTENNA FACTOR (dB/m)	CABLE LOSS (dB)	PREAMP FACTOR (dB)	ANTENNA HEIGHT (cm)	TABLE ANGLE (Degree)	REMARK
83.73	19.02	41.5	40	-20.98	8.18	0.99	31.65	110	4	Peak
128.28	25.07	44.17	43.5	-18.43	11.55	1.23	31.88	100	334	Peak
195.51	27.2	47.72	43.5	-16.3	9.64	1.57	31.73	129	313	Peak
317.5	20.77	37.21	46	-25.23	13.36	2.11	31.91	107	64	Peak
438.6	18.57	31.9	46	-27.43	16.1	2.57	32	102	274	Peak
621.3	22.97	32.11	46	-23.03	19.87	3.15	32.16	137	306	Peak

ANTENNA POLARITY & TEST DISTANCE: VERTICAL AT 3 M										
FREQ. (MHz)	EMISSION LEVEL (dBuV/m)	READ LEVEL (dBuV)	LIMIT (dBuV/m)	MARGIN (dB)	ANTENNA FACTOR (dB/m)	CABLE LOSS (dB)	PREAMP FACTOR (dB)	ANTENNA HEIGHT (cm)	TABLE ANGLE (Degree)	REMARK
31.89	22.57	40.8	40	-17.43	12.3	0.58	31.11	110	287	Peak
81.3	29.41	51.84	40	-10.59	8.15	0.98	31.56	121	282	Peak
128.55	29.1	48.14	43.5	-14.4	11.61	1.23	31.88	129	93	Peak
331.5	16.61	32.55	46	-29.39	13.71	2.16	31.81	114	184	Peak
514.9	20.53	31.62	46	-25.47	17.66	2.83	31.58	122	281	Peak
650.7	24	32.55	46	-22	20.22	3.24	32.01	117	357	Peak

**REMARKS:** Emission Level = Read Level + Antenna Factor + Cable Loss - Preamp Factor  
 Margin value = Emission level – Limit value



A D T

EUT TEST CONDITION		MEASUREMENT DETAIL	
CHANNEL	Channel 13	FREQUENCY RANGE	30MHz ~ 1GHz
INPUT POWER	120Vac, 60 Hz	DETECTOR FUNCTION	Peak (PK)
ENVIRONMENTAL CONDITIONS	25deg. C, 65%RH	TESTED BY	Gavin Wu

ANTENNA POLARITY & TEST DISTANCE: HORIZONTAL AT 3 M										
FREQ. (MHz)	EMISSION LEVEL (dBuV/m)	READ LEVEL (dBuV)	LIMIT (dBuV/m)	MARGIN (dB)	ANTENNA FACTOR (dB/m)	CABLE LOSS (dB)	PREAMP FACTOR (dB)	ANTENNA HEIGHT (cm)	TABLE ANGLE (Degree)	REMARK
83.73	17.78	40.26	40	-22.22	8.18	0.99	31.65	105	110	Peak
127.74	24.62	43.72	43.5	-18.88	11.55	1.23	31.88	107	37	Peak
196.05	27.22	47.74	43.5	-16.28	9.64	1.57	31.73	114	173	Peak
300	18.96	35.81	46	-27.04	12.94	2.05	31.84	101	154	Peak
424.6	18.28	31.96	46	-27.72	15.83	2.52	32.03	134	50	Peak
694.8	24.52	32.18	46	-21.48	20.75	3.41	31.82	105	281	Peak
ANTENNA POLARITY & TEST DISTANCE: VERTICAL AT 3 M										
FREQ. (MHz)	EMISSION LEVEL (dBuV/m)	READ LEVEL (dBuV)	LIMIT (dBuV/m)	MARGIN (dB)	ANTENNA FACTOR (dB/m)	CABLE LOSS (dB)	PREAMP FACTOR (dB)	ANTENNA HEIGHT (cm)	TABLE ANGLE (Degree)	REMARK
31.62	24.39	42.62	40	-15.61	12.3	0.58	31.11	129	350	Peak
84	29.11	51.61	40	-10.89	8.2	0.99	31.69	100	289	Peak
127.74	29.62	48.72	43.5	-13.88	11.55	1.23	31.88	100	129	Peak
393.1	17.34	31.84	46	-28.66	15.17	2.4	32.07	131	53	Peak
526.1	20.96	31.82	46	-25.04	17.91	2.87	31.64	129	28	Peak
676.6	24.71	32.66	46	-21.29	20.54	3.34	31.83	102	93	Peak

**REMARKS:** Emission Level = Read Level + Antenna Factor + Cable Loss - Preamp Factor  
 Margin value = Emission level – Limit value



A D T

**802.11n (20MHz)**

EUT TEST CONDITION		MEASUREMENT DETAIL	
CHANNEL	Channel 1	FREQUENCY RANGE	30MHz ~ 1GHz
INPUT POWER	120Vac, 60 Hz	DETECTOR FUNCTION	Peak (PK)
ENVIRONMENTAL CONDITIONS	25deg. C, 65%RH	TESTED BY	Gavin Wu

**ANTENNA POLARITY & TEST DISTANCE: HORIZONTAL AT 3 M**

FREQ. (MHz)	EMISSION LEVEL (dBuV/m)	READ LEVEL (dBuV)	LIMIT (dBuV/m)	MARGIN (dB)	ANTENNA FACTOR (dB/m)	CABLE LOSS (dB)	PREAMP FACTOR (dB)	ANTENNA HEIGHT (cm)	TABLE ANGLE (Degree)	REMARK
82.92	20.18	42.66	40	-19.82	8.18	0.99	31.65	129	342	Peak
125.58	26.11	45.36	43.5	-17.39	11.42	1.22	31.89	139	119	Peak
188.22	29.44	49.41	43.5	-14.06	10.19	1.54	31.7	120	186	Peak
311.2	22.17	38.8	46	-23.83	13.22	2.09	31.94	115	264	Peak
479.2	21.8	34.03	46	-24.2	16.91	2.71	31.85	112	203	Peak
628.3	25.01	34.04	46	-20.99	19.95	3.17	32.15	121	280	Peak

**ANTENNA POLARITY & TEST DISTANCE: VERTICAL AT 3 M**

FREQ. (MHz)	EMISSION LEVEL (dBuV/m)	READ LEVEL (dBuV)	LIMIT (dBuV/m)	MARGIN (dB)	ANTENNA FACTOR (dB/m)	CABLE LOSS (dB)	PREAMP FACTOR (dB)	ANTENNA HEIGHT (cm)	TABLE ANGLE (Degree)	REMARK
30.81	26.96	45.37	40	-13.04	12.14	0.57	31.12	134	318	Peak
82.38	30.05	52.51	40	-9.95	8.16	0.98	31.6	104	143	Peak
126.12	29.59	48.84	43.5	-13.91	11.42	1.22	31.89	109	135	Peak
347.6	18.11	33.64	46	-27.89	14.08	2.22	31.83	122	106	Peak
500.2	22.99	34.5	46	-23.01	17.33	2.78	31.62	125	133	Peak
651.4	24.92	33.45	46	-21.08	20.23	3.25	32.01	132	37	Peak

**REMARKS:** Emission Level = Read Level + Antenna Factor + Cable Loss - Preamp Factor  
 Margin value = Emission level – Limit value



A D T

EUT TEST CONDITION		MEASUREMENT DETAIL	
CHANNEL	Channel 6	FREQUENCY RANGE	30MHz ~ 1GHz
INPUT POWER	120Vac, 60 Hz	DETECTOR FUNCTION	Peak (PK)
ENVIRONMENTAL CONDITIONS	25deg. C, 65%RH	TESTED BY	Gavin Wu

**ANTENNA POLARITY & TEST DISTANCE: HORIZONTAL AT 3 M**

FREQ. (MHz)	EMISSION LEVEL (dBuV/m)	READ LEVEL (dBuV)	LIMIT (dBuV/m)	MARGIN (dB)	ANTENNA FACTOR (dB/m)	CABLE LOSS (dB)	PREAMP FACTOR (dB)	ANTENNA HEIGHT (cm)	TABLE ANGLE (Degree)	REMARK
82.92	20.65	43.13	40	-19.35	8.18	0.99	31.65	140	56	Peak
126.39	24.74	43.99	43.5	-18.76	11.42	1.22	31.89	117	359	Peak
193.35	29.25	49.55	43.5	-14.25	9.84	1.56	31.7	124	259	Peak
314.7	22.12	38.62	46	-23.88	13.31	2.11	31.92	113	33	Peak
458.2	24.35	37.22	46	-21.65	16.48	2.64	31.99	110	149	Peak
638.8	24.73	33.54	46	-21.27	20.08	3.21	32.1	106	196	Peak

**ANTENNA POLARITY & TEST DISTANCE: VERTICAL AT 3 M**

FREQ. (MHz)	EMISSION LEVEL (dBuV/m)	READ LEVEL (dBuV)	LIMIT (dBuV/m)	MARGIN (dB)	ANTENNA FACTOR (dB/m)	CABLE LOSS (dB)	PREAMP FACTOR (dB)	ANTENNA HEIGHT (cm)	TABLE ANGLE (Degree)	REMARK
30.81	26.13	44.54	40	-13.87	12.14	0.57	31.12	113	96	Peak
79.68	28.96	51.16	40	-11.04	8.37	0.97	31.54	101	173	Peak
125.58	28.75	48	43.5	-14.75	11.42	1.22	31.89	132	207	Peak
329.4	18.65	34.64	46	-27.35	13.66	2.16	31.81	127	147	Peak
457.5	24.32	37.19	46	-21.68	16.48	2.64	31.99	127	228	Peak
686.4	25.27	33.07	46	-20.73	20.66	3.38	31.84	123	263	Peak

**REMARKS:** Emission Level = Read Level + Antenna Factor + Cable Loss - Preamp Factor

Margin value = Emission level – Limit value



A D T

EUT TEST CONDITION		MEASUREMENT DETAIL	
CHANNEL	Channel 11	FREQUENCY RANGE	30MHz ~ 1GHz
INPUT POWER	120Vac, 60 Hz	DETECTOR FUNCTION	Peak (PK)
ENVIRONMENTAL CONDITIONS	25deg. C, 65%RH	TESTED BY	Gavin Wu

**ANTENNA POLARITY & TEST DISTANCE: HORIZONTAL AT 3 M**

FREQ. (MHz)	EMISSION LEVEL (dBuV/m)	READ LEVEL (dBuV)	LIMIT (dBuV/m)	MARGIN (dB)	ANTENNA FACTOR (dB/m)	CABLE LOSS (dB)	PREAMP FACTOR (dB)	ANTENNA HEIGHT (cm)	TABLE ANGLE (Degree)	REMARK
82.92	19.34	41.82	40	-20.66	8.18	0.99	31.65	108	25	Peak
126.12	24.76	44.01	43.5	-18.74	11.42	1.22	31.89	114	115	Peak
187.95	29.63	49.6	43.5	-13.87	10.19	1.54	31.7	117	273	Peak
308.4	21.68	38.38	46	-24.32	13.15	2.08	31.93	119	223	Peak
479.2	22.63	34.86	46	-23.37	16.91	2.71	31.85	107	128	Peak
624.8	25.17	34.27	46	-20.83	19.9	3.16	32.16	119	220	Peak

**ANTENNA POLARITY & TEST DISTANCE: VERTICAL AT 3 M**

FREQ. (MHz)	EMISSION LEVEL (dBuV/m)	READ LEVEL (dBuV)	LIMIT (dBuV/m)	MARGIN (dB)	ANTENNA FACTOR (dB/m)	CABLE LOSS (dB)	PREAMP FACTOR (dB)	ANTENNA HEIGHT (cm)	TABLE ANGLE (Degree)	REMARK
30.81	26.03	44.44	40	-13.97	12.14	0.57	31.12	131	335	Peak
82.92	31.77	54.25	40	-8.23	8.18	0.99	31.65	115	22	Peak
126.12	31.2	50.45	43.5	-12.3	11.42	1.22	31.89	118	307	Peak
421.8	19.69	33.45	46	-26.31	15.77	2.51	32.04	126	74	Peak
500.9	22.32	33.83	46	-23.68	17.33	2.78	31.62	115	170	Peak
679.4	25.59	33.52	46	-20.41	20.56	3.35	31.84	120	316	Peak

**REMARKS:** Emission Level = Read Level + Antenna Factor + Cable Loss - Preamp Factor

Margin value = Emission level – Limit value



A D T

EUT TEST CONDITION		MEASUREMENT DETAIL	
CHANNEL	Channel 12	FREQUENCY RANGE	30MHz ~ 1GHz
INPUT POWER	120Vac, 60 Hz	DETECTOR FUNCTION	Peak (PK)
ENVIRONMENTAL CONDITIONS	25deg. C, 65%RH	TESTED BY	Gavin Wu

ANTENNA POLARITY & TEST DISTANCE: HORIZONTAL AT 3 M										
FREQ. (MHz)	EMISSION LEVEL (dBuV/m)	READ LEVEL (dBuV)	LIMIT (dBuV/m)	MARGIN (dB)	ANTENNA FACTOR (dB/m)	CABLE LOSS (dB)	PREAMP FACTOR (dB)	ANTENNA HEIGHT (cm)	TABLE ANGLE (Degree)	REMARK
83.73	18.81	41.29	40	-21.19	8.18	0.99	31.65	127	25	Peak
128.55	23.74	42.78	43.5	-19.76	11.61	1.23	31.88	116	62	Peak
181.74	27.55	47.19	43.5	-15.95	10.67	1.51	31.82	102	16	Peak
307.7	19.66	36.37	46	-26.34	13.13	2.08	31.92	115	285	Peak
428.1	19.52	33.12	46	-26.48	15.89	2.53	32.02	110	284	Peak
580.7	21.6	31.52	46	-24.4	19.17	3.03	32.12	126	47	Peak

ANTENNA POLARITY & TEST DISTANCE: VERTICAL AT 3 M										
FREQ. (MHz)	EMISSION LEVEL (dBuV/m)	READ LEVEL (dBuV)	LIMIT (dBuV/m)	MARGIN (dB)	ANTENNA FACTOR (dB/m)	CABLE LOSS (dB)	PREAMP FACTOR (dB)	ANTENNA HEIGHT (cm)	TABLE ANGLE (Degree)	REMARK
31.62	23.42	41.65	40	-16.58	12.3	0.58	31.11	101	241	Peak
84	25.73	48.23	40	-14.27	8.2	0.99	31.69	120	146	Peak
128.55	26.23	45.27	43.5	-17.27	11.61	1.23	31.88	130	251	Peak
363	16.53	31.76	46	-29.47	14.45	2.28	31.96	126	128	Peak
551.3	21.97	32.5	46	-24.03	18.48	2.95	31.96	116	111	Peak
647.9	23.68	32.29	46	-22.32	20.19	3.23	32.03	130	283	Peak

**REMARKS:** Emission Level = Read Level + Antenna Factor + Cable Loss - Preamp Factor  
 Margin value = Emission level – Limit value



A D T

EUT TEST CONDITION		MEASUREMENT DETAIL	
CHANNEL	Channel 13	FREQUENCY RANGE	30MHz ~ 1GHz
INPUT POWER	120Vac, 60 Hz	DETECTOR FUNCTION	Peak (PK)
ENVIRONMENTAL CONDITIONS	25deg. C, 65%RH	TESTED BY	Gavin Wu

ANTENNA POLARITY & TEST DISTANCE: HORIZONTAL AT 3 M										
FREQ. (MHz)	EMISSION LEVEL (dBuV/m)	READ LEVEL (dBuV)	LIMIT (dBuV/m)	MARGIN (dB)	ANTENNA FACTOR (dB/m)	CABLE LOSS (dB)	PREAMP FACTOR (dB)	ANTENNA HEIGHT (cm)	TABLE ANGLE (Degree)	REMARK
83.73	18.04	40.52	40	-21.96	8.18	0.99	31.65	132	74	Peak
128.55	23.81	42.85	43.5	-19.69	11.61	1.23	31.88	120	160	Peak
194.43	28.53	48.98	43.5	-14.97	9.7	1.57	31.72	113	149	Peak
332.2	18.18	34.09	46	-27.82	13.73	2.17	31.81	107	181	Peak
567.4	21.34	31.55	46	-24.66	18.86	3	32.07	117	31	Peak
671.7	23.2	31.21	46	-22.8	20.48	3.33	31.82	128	323	Peak
ANTENNA POLARITY & TEST DISTANCE: VERTICAL AT 3 M										
FREQ. (MHz)	EMISSION LEVEL (dBuV/m)	READ LEVEL (dBuV)	LIMIT (dBuV/m)	MARGIN (dB)	ANTENNA FACTOR (dB/m)	CABLE LOSS (dB)	PREAMP FACTOR (dB)	ANTENNA HEIGHT (cm)	TABLE ANGLE (Degree)	REMARK
31.89	22.54	40.77	40	-17.46	12.3	0.58	31.11	138	269	Peak
78.06	27.03	49.03	40	-12.97	8.61	0.96	31.57	111	17	Peak
123.69	29.42	48.82	43.5	-14.08	11.28	1.21	31.89	103	292	Peak
358.1	18.17	33.52	46	-27.83	14.33	2.26	31.94	102	184	Peak
514.9	21.48	32.57	46	-24.52	17.66	2.83	31.58	123	161	Peak
643	23.26	31.98	46	-22.74	20.13	3.22	32.07	106	104	Peak

**REMARKS:** Emission Level = Read Level + Antenna Factor + Cable Loss - Preamp Factor  
 Margin value = Emission level – Limit value



## 4.2 CONDUCTED EMISSION MEASUREMENT

### 4.2.1 LIMITS OF CONDUCTED EMISSION MEASUREMENT

FREQUENCY OF EMISSION (MHz)	CONDUCTED LIMIT (dB $\mu$ V)	
	Quasi-peak	Average
0.15 ~ 0.5	66 to 56	56 to 46
0.5 ~ 5	56	46
5 ~ 30	60	50

- NOTE:**
1. The lower limit shall apply at the transition frequencies.
  2. The limit decreases in line with the logarithm of the frequency in the range of 0.15 to 0.50MHz.
  3. All emanations from a class A/B digital device or system, including any network of conductors and apparatus connected thereto, shall not exceed the level of field strengths specified above.

### 4.2.2 TEST INSTRUMENTS

DESCRIPTION & MANUFACTURER	MODEL NO.	SERIAL NO.	DATE OF CALIBRATION	DUE DATE OF CALIBRATION
Test Receiver ROHDE & SCHWARZ	ESCI	100613	Nov. 11, 2014	Nov. 10, 2015
RF signal cable Woken	5D-FB	Cable-HYC01-01	Dec. 26, 2014	Dec. 25, 2015
LISN ROHDE & SCHWARZ (EUT)	ESH3-Z5	835239/001	Mar. 02, 2015	Mar. 01, 2016
LISN ROHDE & SCHWARZ (Peripheral)	ESH3-Z5	100311	Jul. 21, 2014	Jul. 20, 2015
Software ADT	BV ADT_Cond_ V7.3.7.3	NA	NA	NA

- NOTE:**
1. The calibration interval of the above test instruments is 12 months and the calibrations are traceable to NML/ROC and NIST/USA.
  2. The test was performed in HwaYa Shielded Room 1.
  3. The VCCI Site Registration No. is C-2047.

#### 4.2.3 TEST PROCEDURES

- a. The EUT was placed 0.4 meters from the conducting wall of the shielded room with EUT being connected to the power mains through a line impedance stabilization network (LISN). Other support units were connected to the power mains through another LISN. The two LISNs provide 50 ohm/ 50uH of coupling impedance for the measuring instrument.
- b. Both lines of the power mains connected to the EUT were checked for maximum conducted interference.
- c. The frequency range from 150kHz to 30MHz was searched. Emission levels under (Limit - 20dB) was not recorded.

**NOTE:** All modes of operation were investigated and the worst-case emissions are reported.

#### 4.2.4 DEVIATION FROM TEST STANDARD

No deviation.

#### 4.2.5 TEST SETUP

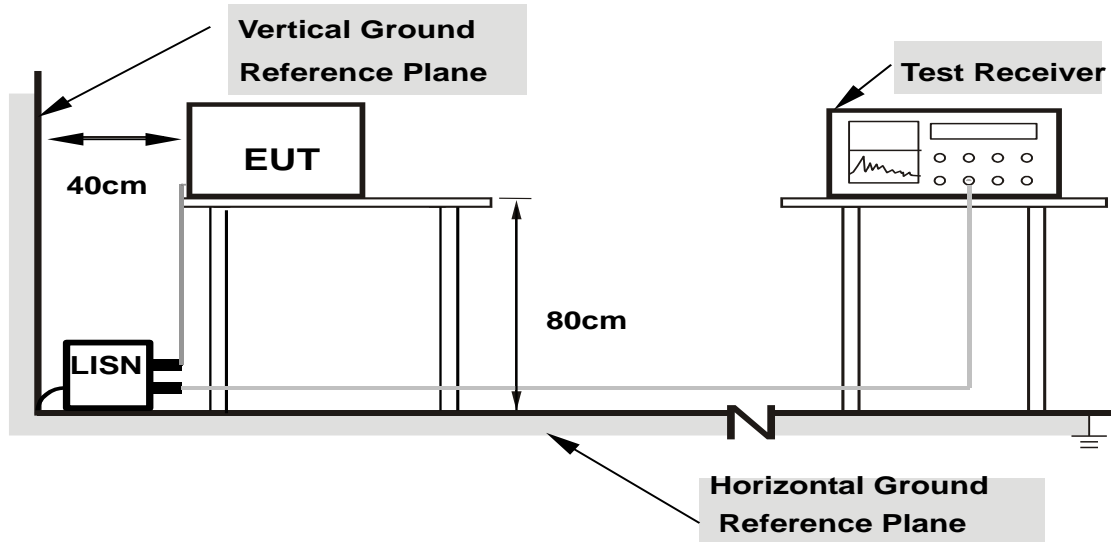

- Note:**
1. Support units were connected to second LISN.
  2. Both of LISNs (AMN) are 80 cm from EUT and at least 80 from other units and other metal planes

For the actual test configuration, please refer to the attached file (Test Setup Photo).

#### 4.2.6 EUT OPERATING CONDITIONS

Same as section 4.1.6.

#### 4.2.7 TEST RESULTS

##### CONDUCTED WORST-CASE DATA :

##### Mode A

<b>PHASE</b>	Line 1	<b>6dB BANDWIDTH</b>	9kHz
<b>FUNCTION TYPE</b>	WLAN 2.4G Tx + Adapter + USB Cable + Earphone		

No	Frequency (MHz)	Correction Factor (dB)	Reading Value (dBuV)		Emission Level (dBuV)		Limit (dBuV)		Margin (dB)	
			Q.P.	AV.	Q.P.	AV.	Q.P.	AV.	Q.P.	AV.
1	0.16526	0.05	46.50	31.68	46.55	31.73	65.20	55.20	-18.64	-23.46
2	0.20865	0.06	43.67	29.79	43.73	29.85	63.26	53.26	-19.53	-23.41
3	0.28685	0.06	39.96	31.45	40.02	31.51	60.62	50.62	-20.60	-19.11
4	0.33377	0.06	42.26	34.24	42.32	34.30	59.36	49.36	-17.04	-15.06
5	0.37700	0.06	39.52	34.21	39.58	34.27	58.35	48.35	-18.77	-14.08
6	1.02878	0.08	38.83	28.27	38.91	28.35	56.00	46.00	-17.09	-17.65

##### Remarks:

1. Q.P. and AV. are abbreviations of quasi-peak and average individually.
2. The emission levels of other frequencies were very low against the limit.
3. Margin value = Emission level – Limit value
4. Correction factor = Insertion loss + Cable loss
5. Emission Level = Correction Factor + Reading Value

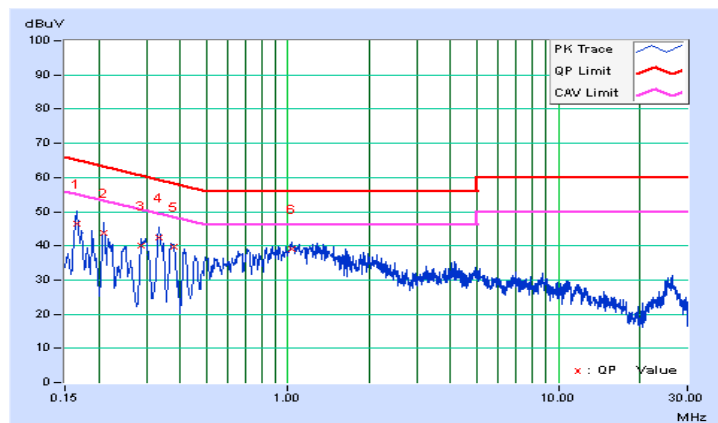

<b>PHASE</b>	Line 2	<b>6dB BANDWIDTH</b>	9kHz
<b>FUNCTION TYPE</b>	WLAN 2.4G Tx + Adapter + USB Cable + Earphone		

No	Frequency (MHz)	Correction Factor (dB)	Reading Value (dBuV)		Emission Level (dBuV)		Limit (dBuV)		Margin (dB)	
			Q.P.	AV.	Q.P.	AV.	Q.P.	AV.	Q.P.	AV.
1	0.16569	0.05	46.70	33.83	46.75	33.88	65.17	55.17	-18.42	-21.29
2	0.20893	0.05	43.97	31.51	44.02	31.56	63.25	53.25	-19.23	-21.69
3	0.29858	0.05	44.84	37.43	44.89	37.48	60.28	50.28	-15.39	-12.80
<b>4</b>	<b>0.37700</b>	<b>0.06</b>	<b>43.23</b>	<b>38.61</b>	<b>43.29</b>	<b>38.67</b>	<b>58.35</b>	<b>48.35</b>	<b>-15.06</b>	<b>-9.68</b>
5	1.03968	0.08	37.88	29.90	37.96	29.98	56.00	46.00	-18.04	-16.02
6	1.71522	0.10	36.75	29.22	36.85	29.32	56.00	46.00	-19.15	-16.68

Remarks:

1. Q.P. and AV. are abbreviations of quasi-peak and average individually.
2. The emission levels of other frequencies were very low against the limit.
3. Margin value = Emission level – Limit value
4. Correction factor = Insertion loss + Cable loss
5. Emission Level = Correction Factor + Reading Value

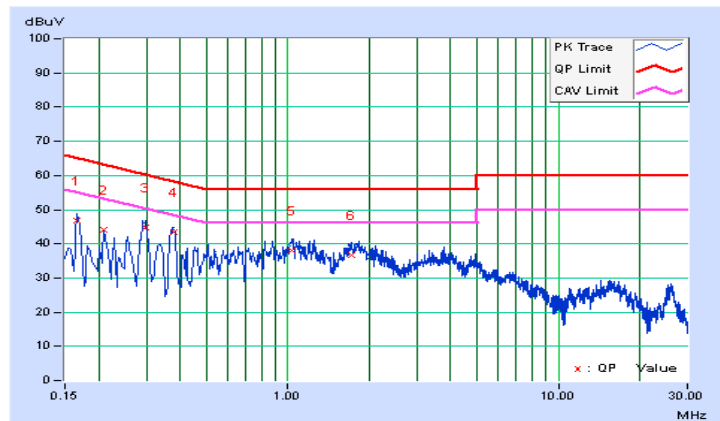



A D T

**Mode B**

<b>PHASE</b>	Line 1	<b>6dB BANDWIDTH</b>	9kHz
<b>FUNCTION TYPE</b>	WLAN 2.4G Tx + Adapter + USB Cable + Earphone		

No	Frequency (MHz)	Correction Factor (dB)	Reading Value (dBuV)		Emission Level (dBuV)		Limit (dBuV)		Margin (dB)	
			Q.P.	AV.	Q.P.	AV.	Q.P.	AV.	Q.P.	AV.
1	0.16967	0.05	38.45	28.31	38.50	28.36	64.98	54.98	-26.47	-26.61
2	0.21256	0.06	38.70	27.09	38.76	27.15	63.10	53.10	-24.34	-25.95
3	0.28739	0.06	41.00	36.11	41.06	36.17	60.60	50.60	-19.54	-14.43
4	0.32187	0.06	38.27	25.66	38.33	25.72	59.66	49.66	-21.33	-23.94
5	0.37304	0.06	40.89	36.61	40.95	36.67	58.43	48.43	-17.48	-11.76
6	1.08840	0.08	37.94	27.60	38.02	27.68	56.00	46.00	-17.98	-18.32

Remarks:

1. Q.P. and AV. are abbreviations of quasi-peak and average individually.
2. The emission levels of other frequencies were very low against the limit.
3. Margin value = Emission level – Limit value
4. Correction factor = Insertion loss + Cable loss
5. Emission Level = Correction Factor + Reading Value

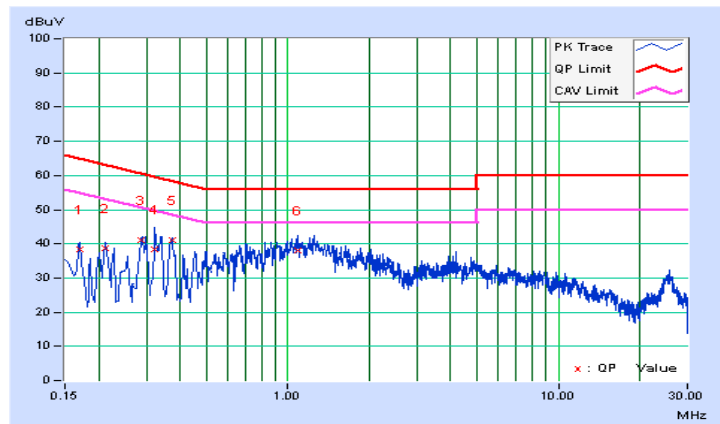



A D T

<b>PHASE</b>	Line 2	<b>6dB BANDWIDTH</b>	9kHz
<b>FUNCTION TYPE</b>	WLAN 2.4G Tx + Adapter + USB Cable + Earphone		

No	Frequency (MHz)	Correction Factor (dB)	Reading Value (dBuV)		Emission Level (dBuV)		Limit (dBuV)		Margin (dB)	
			Q.P.	AV.	Q.P.	AV.	Q.P.	AV.	Q.P.	AV.
1	0.16181	0.05	44.04	33.25	44.09	33.30	65.37	55.37	-21.28	-22.07
2	0.20474	0.05	45.01	33.43	45.06	33.48	63.42	53.42	-18.36	-19.94
3	0.29043	0.05	45.77	41.15	45.82	41.20	60.51	50.51	-14.69	-9.31
<b>4</b>	<b>0.37304</b>	<b>0.06</b>	<b>44.20</b>	<b>40.11</b>	<b>44.26</b>	<b>40.17</b>	<b>58.43</b>	<b>48.43</b>	<b>-14.17</b>	<b>-8.26</b>
5	0.81861	0.07	38.81	31.47	38.88	31.54	56.00	46.00	-17.12	-14.46
6	1.19788	0.09	40.13	31.59	40.22	31.68	56.00	46.00	-15.78	-14.32

Remarks:

1. Q.P. and AV. are abbreviations of quasi-peak and average individually.
2. The emission levels of other frequencies were very low against the limit.
3. Margin value = Emission level – Limit value
4. Correction factor = Insertion loss + Cable loss
5. Emission Level = Correction Factor + Reading Value

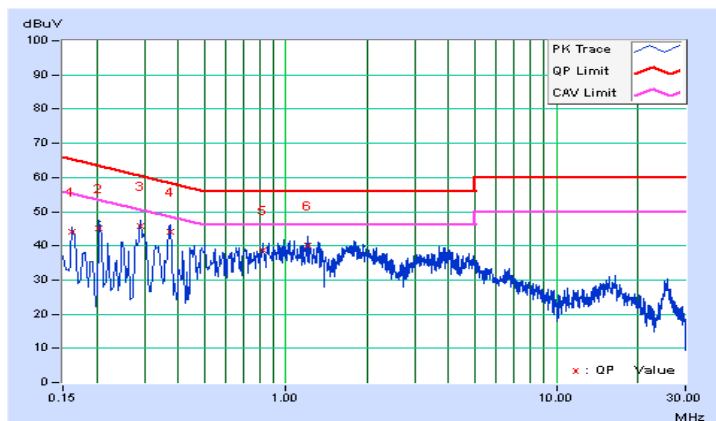

## 4.3 6dB BANDWIDTH MEASUREMENT

### 4.3.1 LIMITS OF 6dB BANDWIDTH MEASUREMENT

The minimum of 6dB Bandwidth Measurement is 0.5 MHz.

### 4.3.2 TEST SETUP

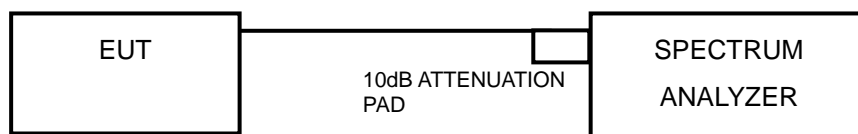

### 4.3.3 TEST INSTRUMENTS

Refer to section 4.1.2 to get information of above instrument.

### 4.3.4 TEST PROCEDURE

- Set resolution bandwidth (RBW) = 100kHz
- Set the video bandwidth (VBW)  $\geq 3 \times$  RBW, Detector = Peak.
- Trace mode = max hold.
- Sweep = auto couple.
- Measure the maximum width of the emission that is constrained by the frequencies associated with the two amplitude points (upper and lower) that are attenuated by 6 dB relative to the maximum level measured in the fundamental emission

### 4.3.5 DEVIATION FROM TEST STANDARD

No deviation.

### 4.3.6 EUT OPERATING CONDITIONS

The software provided by client to enable the EUT under transmission condition continuously at lowest, middle and highest channel frequencies individually.





A D T

#### 4.3.7 TEST RESULTS

##### Mode A

##### 802.11b

CHANNEL	FREQUENCY (MHz)	6dB BANDWIDTH (MHz)	MINIMUM LIMIT (MHz)	PASS / FAIL
1	2412	9.10	0.5	PASS
6	2437	12.10	0.5	PASS
11	2462	10.05	0.5	PASS

##### 802.11g

CHANNEL	FREQUENCY (MHz)	6dB BANDWIDTH (MHz)	MINIMUM LIMIT (MHz)	PASS / FAIL
1	2412	12.16	0.5	PASS
6	2437	15.51	0.5	PASS
11	2462	13.85	0.5	PASS

##### 802.11n (20MHz)

CHANNEL	FREQUENCY (MHz)	6dB BANDWIDTH (MHz)	MINIMUM LIMIT (MHz)	PASS / FAIL
1	2412	13.88	0.5	PASS
6	2437	15.12	0.5	PASS
11	2462	15.14	0.5	PASS



A D T

### SPECTRUM PLOT OF WORST VALUE

#### 802.11b

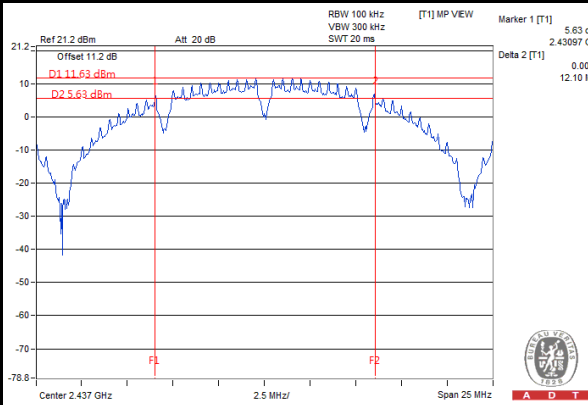

#### 802.11g

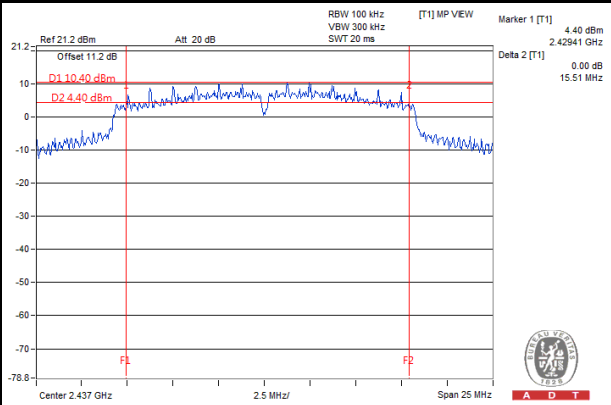

#### 802.11n (20MHz)

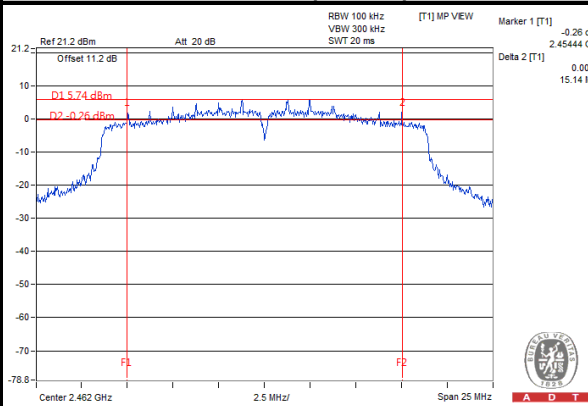



A D T

**Mode B**

**802.11b**

CHANNEL	FREQUENCY (MHz)	6dB BANDWIDTH (MHz)	MINIMUM LIMIT (MHz)	PASS / FAIL
1	2412	9.56	0.5	PASS
6	2437	10.10	0.5	PASS
11	2462	9.57	0.5	PASS

**802.11g**

CHANNEL	FREQUENCY (MHz)	6dB BANDWIDTH (MHz)	MINIMUM LIMIT (MHz)	PASS / FAIL
1	2412	15.15	0.5	PASS
6	2437	15.09	0.5	PASS
11	2462	15.08	0.5	PASS

**802.11n (20MHz)**

CHANNEL	FREQUENCY (MHz)	6dB BANDWIDTH (MHz)	MINIMUM LIMIT (MHz)	PASS / FAIL
1	2412	15.13	0.5	PASS
6	2437	15.14	0.5	PASS
11	2462	15.17	0.5	PASS



A D T

### SPECTRUM PLOT OF WORST VALUE

#### 802.11b

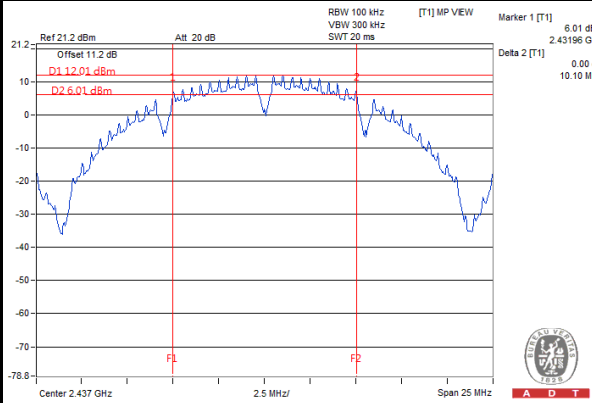

#### 802.11g

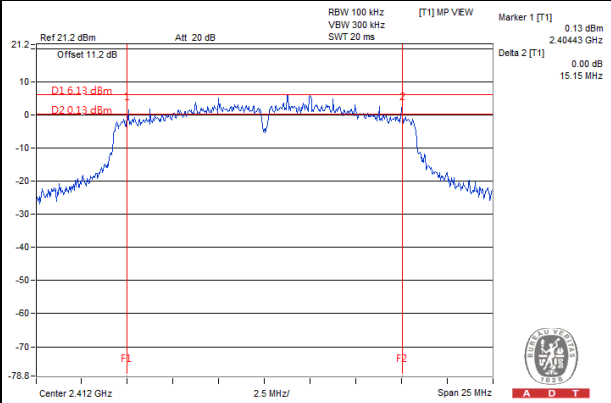

#### 802.11n (20MHz)

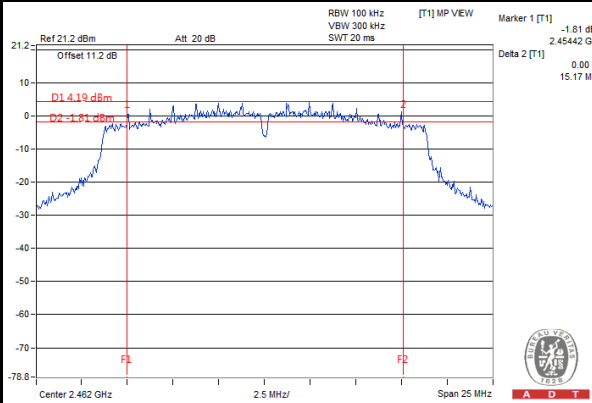

## 4.4 CONDUCTED OUTPUT POWER

### 4.4.1 LIMITS OF CONDUCTED OUTPUT POWER MEASUREMENT

For systems using digital modulation in the 2400–2483.5 MHz bands: 1 Watt (30dBm)

### 4.4.2 TEST SETUP

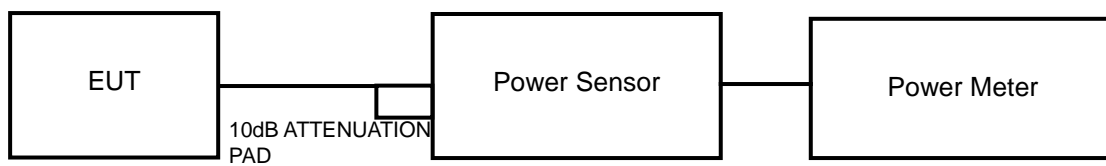

### 4.4.3 TEST INSTRUMENTS

Refer to section 4.1.2 to get information of above instrument.

### 4.4.4 TEST PROCEDURES

A peak power sensor was used on the output port of the EUT. A power meter was used to read the response of the peak power sensor. Record the peak power level.

### 4.4.5 DEVIATION FROM TEST STANDARD

No deviation.

### 4.4.6 EUT OPERATING CONDITIONS

Same as section 4.3.6.



A D T

#### 4.4.7 TEST RESULTS

##### Mode A

<FOR PEAK POWER>

##### 802.11b\_Ant. A

CHANNEL	FREQUENCY (MHz)	CHAIN	DATA RATE			
			1M bps	2M bps	5.5M bps	11M bps
1	2412	A	22.31	22.27	22.02	22.03
6	2437	A	22.25	22.13	22.11	22.11
11	2462	A	22.75	22.74	22.41	22.52
12	2467	A	1.88	1.87	1.86	1.87
13	2472	A	1.77	1.75	1.73	1.76

CHANNEL	FREQUENCY (MHz)	PEAK POWER (mW)	PEAK POWER (dBm)	LIMIT (dBm)	PASS / FAIL
1	2412	170.22	22.31	30	PASS
6	2437	167.88	22.25	30	PASS
11	2462	188.36	22.75	30	PASS
12	2467	1.54	1.88	30	PASS
13	2472	1.50	1.77	30	PASS

##### 802.11b\_Ant. B

CHANNEL	FREQUENCY (MHz)	CHAIN	DATA RATE			
			1M bps	2M bps	5.5M bps	11M bps
1	2412	B	22.26	22.24	22.21	22.19
6	2437	B	22.69	22.67	22.65	22.64
11	2462	B	22.52	22.5	22.03	22.14
12	2467	B	2.44	2.42	2.41	2.39
13	2472	B	2.36	2.35	2.33	2.34

CHANNEL	FREQUENCY (MHz)	PEAK POWER (mW)	PEAK POWER (dBm)	LIMIT (dBm)	PASS / FAIL
1	2412	168.27	22.26	30	PASS
6	2437	185.78	22.69	30	PASS
11	2462	178.65	22.52	30	PASS
12	2467	1.75	2.44	30	PASS
13	2472	1.72	2.36	30	PASS



A D T

### 802.11g\_Ant. A

CHANNEL	FREQUENCY (MHz)	CHAIN	DATA RATE							
			6M bps	9M bps	12M bps	18M bps	24M bps	36M bps	48M bps	54M bps
1	2412	A	22.97	22.92	22.95	22.93	22.95	22.94	22.96	22.95
6	2437	A	23.03	22.89	23.01	22.99	22.92	22.92	22.97	22.97
11	2462	A	23.49	23.47	23.48	23.42	23.47	23.45	23.44	23.45
12	2467	A	10.7	10.68	10.65	10.69	10.64	10.63	10.66	10.62
13	2472	A	10.5	10.46	10.47	10.42	10.46	10.43	10.42	10.4

CHANNEL	FREQUENCY (MHz)	PEAK POWER (mW)	PEAK POWER (dBm)	LIMIT (dBm)	PASS / FAIL
1	2412	198.15	22.97	30	PASS
6	2437	200.91	23.03	30	PASS
11	2462	223.36	23.49	30	PASS
12	2467	11.75	10.7	30	PASS
13	2472	11.22	10.5	30	PASS

### 802.11g\_Ant. B

CHANNEL	FREQUENCY (MHz)	CHAIN	DATA RATE							
			6M bps	9M bps	12M bps	18M bps	24M bps	36M bps	48M bps	54M bps
1	2412	B	22.89	22.89	22.86	22.85	22.87	22.86	22.88	22.82
6	2437	B	23.35	23.24	23.31	23.29	23.32	23.3	23.31	23.34
11	2462	B	23.46	23.41	23.35	23.45	23.41	23.45	23.43	23.44
12	2467	B	10.01	9.97	9.94	9.92	9.95	9.93	9.91	9.9
13	2472	B	10.16	10.14	10.12	10.09	10.08	10.04	10.13	10.1

CHANNEL	FREQUENCY (MHz)	PEAK POWER (mW)	PEAK POWER (dBm)	LIMIT (dBm)	PASS / FAIL
1	2412	194.54	22.89	30	PASS
6	2437	216.27	23.35	30	PASS
11	2462	221.82	23.46	30	PASS
12	2467	10.02	10.01	30	PASS
13	2472	10.38	10.16	30	PASS



A D T

### 802.11n (20MHz)\_ Ant. A

CHANNEL	FREQUENCY (MHz)	CHAIN	DATA RATE							
			MCS0	MCS1	MCS2	MCS3	MCS4	MCS5	MCS6	MCS7
1	2412	A	22.34	22.22	22.15	22.12	22.03	22.03	22.12	22.2
6	2437	A	22.92	22.9	22.92	22.9	22.92	22.82	22.86	22.85
11	2462	A	23.53	23.43	23.41	23.47	23.43	23.49	23.48	23.47
12	2467	A	10.62	10.58	10.59	10.54	10.56	10.57	10.54	10.55
13	2472	A	9.48	9.46	9.47	9.45	9.44	9.46	9.43	9.42

CHANNEL	FREQUENCY (MHz)	PEAK POWER (mW)	PEAK POWER (dBm)	LIMIT (dBm)	PASS / FAIL
1	2412	171.40	22.34	30	PASS
6	2437	195.88	22.92	30	PASS
11	2462	225.42	23.53	30	PASS
12	2467	11.53	10.62	30	PASS
13	2472	8.87	9.48	30	PASS

### 802.11n (20MHz)\_ Ant. B

CHANNEL	FREQUENCY (MHz)	CHAIN	DATA RATE							
			MCS0	MCS1	MCS2	MCS3	MCS4	MCS5	MCS6	MCS7
1	2412	B	22.51	22.46	22.47	22.45	22.48	22.46	22.44	22.41
6	2437	B	23.49	23.27	23.47	23.28	23.44	23.47	23.45	23.45
11	2462	B	23.46	23.41	23.34	23.42	23.4	23.38	23.4	23.43
12	2467	B	10.46	10.44	10.43	10.42	10.44	10.45	10.43	10.45
13	2472	B	11.11	11.1	11.09	11.08	11.07	11.09	11.1	11.8

CHANNEL	FREQUENCY (MHz)	PEAK POWER (mW)	PEAK POWER (dBm)	LIMIT (dBm)	PASS / FAIL
1	2412	178.24	22.51	30	PASS
6	2437	223.36	23.49	30	PASS
11	2462	221.82	23.46	30	PASS
12	2467	11.12	10.46	30	PASS
13	2472	15.14	11.8	30	PASS





A D T

<FOR AVERAGE POWER>

**802.11b\_Ant. A**

CHANNEL	FREQUENCY (MHz)	CHAIN	DATA RATE			
			1M bps	2M bps	5.5M bps	11M bps
1	2412	A	20.4	20.35	20.31	20.35
6	2437	A	21.76	21.6	21.52	21.68
11	2462	A	20.8	20.79	20.64	20.76
12	2467	A	-0.52	-0.54	-0.55	-0.53
13	2472	A	-0.63	-0.66	-0.65	-0.66

CHANNEL	FREQUENCY (MHz)	PEAK POWER (mW)	PEAK POWER (dBm)	LIMIT (dBm)	PASS / FAIL
1	2412	109.65	20.4	30	PASS
6	2437	149.97	21.76	30	PASS
11	2462	120.23	20.8	30	PASS
12	2467	0.89	-0.52	30	PASS
13	2472	0.86	-0.63	30	PASS

**802.11b\_Ant. B**

CHANNEL	FREQUENCY (MHz)	CHAIN	DATA RATE			
			1M bps	2M bps	5.5M bps	11M bps
1	2412	B	20.34	20.29	20.26	20.3
6	2437	B	22.18	22.04	22.09	22.11
11	2462	B	20.44	20.44	20.17	20.25
12	2467	B	0.06	0.04	0.05	0.03
13	2472	B	-0.02	-0.04	-0.03	-0.06

CHANNEL	FREQUENCY (MHz)	PEAK POWER (mW)	PEAK POWER (dBm)	LIMIT (dBm)	PASS / FAIL
1	2412	108.14	20.34	30	PASS
6	2437	165.20	22.18	30	PASS
11	2462	110.66	20.44	30	PASS
12	2467	1.01	0.06	30	PASS
13	2472	1.00	-0.02	30	PASS



A D T

### 802.11g\_Ant. A

CHANNEL	FREQUENCY (MHz)	CHAIN	DATA RATE							
			6M bps	9M bps	12M bps	18M bps	24M bps	36M bps	48M bps	54M bps
1	2412	A	17.02	16.93	16.91	17.01	16.91	16.93	16.9	16.9
6	2437	A	21.69	21.41	21.6	21.59	21.45	21.45	21.56	21.56
11	2462	A	16.72	16.64	16.65	16.68	16.6	16.65	16.71	16.67
12	2467	A	-0.25	-0.28	-0.3	-0.29	-0.26	-0.27	-0.26	-0.28
13	2472	A	-0.99	-1.02	-1.03	-1	-1.02	-1.01	-1.2	-1.03

CHANNEL	FREQUENCY (MHz)	PEAK POWER (mW)	PEAK POWER (dBm)	LIMIT (dBm)	PASS / FAIL
1	2412	50.35	17.02	30	PASS
6	2437	147.57	21.69	30	PASS
11	2462	46.99	16.72	30	PASS
12	2467	0.94	-0.25	30	PASS
13	2472	0.80	-0.99	30	PASS

### 802.11g\_Ant. B

CHANNEL	FREQUENCY (MHz)	CHAIN	DATA RATE							
			6M bps	9M bps	12M bps	18M bps	24M bps	36M bps	48M bps	54M bps
1	2412	B	16.58	16.54	16.47	16.51	16.53	16.52	16.51	16.43
6	2437	B	20.53	20.48	20.49	20.46	20.28	20.36	20.41	20.41
11	2462	B	16.71	16.63	16.68	16.62	16.53	16.57	16.59	16.6
12	2467	B	0.53	0.51	0.47	0.5	0.48	0.46	0.51	0.48
13	2472	B	0.14	0.1	0.11	0.09	0.12	0.1	0.13	0.08

CHANNEL	FREQUENCY (MHz)	PEAK POWER (mW)	PEAK POWER (dBm)	LIMIT (dBm)	PASS / FAIL
1	2412	45.50	16.58	30	PASS
6	2437	112.98	20.53	30	PASS
11	2462	46.88	16.71	30	PASS
12	2467	1.13	0.53	30	PASS
13	2472	1.03	0.14	30	PASS



A D T

**802.11n (20MHz)\_ Ant. A**

CHANNEL	FREQUENCY (MHz)	CHAIN	DATA RATE							
			MCS0	MCS1	MCS2	MCS3	MCS4	MCS5	MCS6	MCS7
1	2412	A	15.42	15.34	15.33	15.38	15.39	15.4	15.36	15.41
6	2437	A	21.57	21.48	21.46	21.46	21.48	21.54	21.56	21.54
11	2462	A	16.25	16.18	16.18	16.25	16.14	16.19	16.18	16.21
12	2467	A	-0.19	-0.23	-0.22	-0.2	-0.25	-0.21	-0.23	-0.22
13	2472	A	-0.24	-0.26	-0.25	-0.27	-0.28	-0.25	-0.26	-0.25

CHANNEL	FREQUENCY (MHz)	PEAK POWER (mW)	PEAK POWER (dBm)	LIMIT (dBm)	PASS / FAIL
1	2412	34.83	15.42	30	PASS
6	2437	143.55	21.57	30	PASS
11	2462	42.17	16.25	30	PASS
12	2467	0.96	-0.19	30	PASS
13	2472	0.95	-0.24	30	PASS

**802.11n (20MHz)\_ Ant. B**

CHANNEL	FREQUENCY (MHz)	CHAIN	DATA RATE							
			MCS0	MCS1	MCS2	MCS3	MCS4	MCS5	MCS6	MCS7
1	2412	B	15.04	15.02	14.98	15	14.96	14.95	14.91	14.93
6	2437	B	21.84	21.82	21.83	21.82	21.81	21.81	21.82	21.83
11	2462	B	16.22	16.2	16.17	16.19	16.21	16.16	16.18	16.16
12	2467	B	0.51	0.5	0.49	0.48	0.47	0.49	0.47	0.5
13	2472	B	0.64	0.63	0.62	0.6	0.62	0.61	0.59	0.62

CHANNEL	FREQUENCY (MHz)	PEAK POWER (mW)	PEAK POWER (dBm)	LIMIT (dBm)	PASS / FAIL
1	2412	31.92	15.04	30	PASS
6	2437	152.76	21.84	30	PASS
11	2462	41.88	16.22	30	PASS
12	2467	1.12	0.51	30	PASS
13	2472	1.16	0.64	30	PASS



A D T

**Mode B**

**<FOR PEAK POWER>**

**802.11b\_Ant. A**

CHANNEL	FREQUENCY (MHz)	CHAIN	DATA RATE			
			1M bps	2M bps	5.5M bps	11M bps
1	2412	A	21.39	21.36	21.01	21.01
6	2437	A	22.51	22.41	22.24	22.33
11	2462	A	22.31	22.28	21.79	21.85
12	2467	A	1.88	1.87	1.86	1.87
13	2472	A	1.77	1.75	1.73	1.76

CHANNEL	FREQUENCY (MHz)	PEAK POWER (mW)	PEAK POWER (dBm)	LIMIT (dBm)	PASS / FAIL
1	2412	137.72	21.39	30	PASS
6	2437	178.24	22.51	30	PASS
11	2462	170.22	22.31	30	PASS
12	2467	1.54	1.88	30	PASS
13	2472	1.50	1.77	30	PASS

**802.11b\_Ant. B**

CHANNEL	FREQUENCY (MHz)	CHAIN	DATA RATE			
			1M bps	2M bps	5.5M bps	11M bps
1	2412	B	21.37	21.34	21.34	21.32
6	2437	B	22.42	22.4	22.41	22.38
11	2462	B	22.1	22.07	22.09	22.05
12	2467	B	2.44	2.42	2.41	2.39
13	2472	B	2.36	2.35	2.33	2.34

CHANNEL	FREQUENCY (MHz)	PEAK POWER (mW)	PEAK POWER (dBm)	LIMIT (dBm)	PASS / FAIL
1	2412	137.09	21.37	30	PASS
6	2437	174.58	22.42	30	PASS
11	2462	162.18	22.1	30	PASS
12	2467	1.75	2.44	30	PASS
13	2472	1.72	2.36	30	PASS



A D T

802.11g\_Ant. A

CHANNEL	FREQUENCY (MHz)	CHAIN	DATA RATE							
			6M bps	9M bps	12M bps	18M bps	24M bps	36M bps	48M bps	54M bps
1	2412	A	22.32	22.27	22.28	22.32	22.23	22.31	22.26	22.26
6	2437	A	22.91	22.85	22.88	22.86	22.83	22.84	22.87	22.82
11	2462	A	23.18	23.15	23.1	23.03	23.06	23	23.06	22.99
12	2467	A	10.7	10.68	10.65	10.69	10.64	10.63	10.66	10.62
13	2472	A	10.5	10.46	10.47	10.42	10.46	10.43	10.42	10.4

CHANNEL	FREQUENCY (MHz)	PEAK POWER (mW)	PEAK POWER (dBm)	LIMIT (dBm)	PASS / FAIL
1	2412	170.61	22.32	30	PASS
6	2437	195.43	22.91	30	PASS
11	2462	207.97	23.18	30	PASS
12	2467	11.75	10.7	30	PASS
13	2472	11.22	10.5	30	PASS

802.11g\_Ant. B

CHANNEL	FREQUENCY (MHz)	CHAIN	DATA RATE							
			6M bps	9M bps	12M bps	18M bps	24M bps	36M bps	48M bps	54M bps
1	2412	B	22.86	22.85	22.84	22.81	22.84	22.85	22.8	22.79
6	2437	B	23.39	23.29	23.21	23.27	23.24	23.33	23.26	23.24
11	2462	B	23.04	23.03	23	22.98	22.99	22.95	22.93	22.94
12	2467	B	10.01	9.97	9.94	9.92	9.95	9.93	9.91	9.9
13	2472	B	10.16	10.14	10.12	10.09	10.08	10.04	10.13	10.1

CHANNEL	FREQUENCY (MHz)	PEAK POWER (mW)	PEAK POWER (dBm)	LIMIT (dBm)	PASS / FAIL
1	2412	193.20	22.86	30	PASS
6	2437	218.27	23.39	30	PASS
11	2462	201.37	23.04	30	PASS
12	2467	10.02	10.01	30	PASS
13	2472	10.38	10.16	30	PASS



A D T

**802.11n (20MHz)\_ Ant. A**

CHANNEL	FREQUENCY (MHz)	CHAIN	DATA RATE							
			MCS0	MCS1	MCS2	MCS3	MCS4	MCS5	MCS6	MCS7
1	2412	A	22.34	22.22	22.15	22.12	22.03	22.03	22.12	22.2
6	2437	A	22.88	22.84	22.86	22.79	22.82	22.8	22.79	22.81
11	2462	A	22.92	22.84	22.84	22.8	22.91	22.87	22.84	22.88
12	2467	A	10.62	10.58	10.59	10.54	10.56	10.57	10.54	10.55
13	2472	A	9.48	9.46	9.47	9.45	9.44	9.46	9.43	9.42

CHANNEL	FREQUENCY (MHz)	PEAK POWER (mW)	PEAK POWER (dBm)	LIMIT (dBm)	PASS / FAIL
1	2412	171.40	22.34	30	PASS
6	2437	194.09	22.88	30	PASS
11	2462	195.88	22.92	30	PASS
12	2467	11.53	10.62	30	PASS
13	2472	8.87	9.48	30	PASS

**802.11n (20MHz)\_ Ant. B**

CHANNEL	FREQUENCY (MHz)	CHAIN	DATA RATE							
			MCS0	MCS1	MCS2	MCS3	MCS4	MCS5	MCS6	MCS7
1	2412	B	22.51	22.46	22.47	22.45	22.48	22.46	22.44	22.41
6	2437	B	23.43	23.4	22.39	22.41	22.42	22.4	22.37	22.34
11	2462	B	22.94	22.9	22.88	22.91	22.85	22.86	22.83	22.82
12	2467	B	10.46	10.44	10.43	10.42	10.44	10.45	10.43	10.45
13	2472	B	11.11	11.1	11.09	11.08	11.07	11.09	11.1	11.8

CHANNEL	FREQUENCY (MHz)	PEAK POWER (mW)	PEAK POWER (dBm)	LIMIT (dBm)	PASS / FAIL
1	2412	178.24	22.51	30	PASS
6	2437	220.29	23.43	30	PASS
11	2462	196.79	22.94	30	PASS
12	2467	11.12	10.46	30	PASS
13	2472	15.14	11.8	30	PASS



A D T

<FOR AVERAGE POWER>

**802.11b\_Ant. A**

CHANNEL	FREQUENCY (MHz)	CHAIN	DATA RATE			
			1M bps	2M bps	5.5M bps	11M bps
1	2412	A	19.36	19.35	19.24	19.25
6	2437	A	20.96	20.85	20.91	20.89
11	2462	A	20.24	20.23	19.91	20.03
12	2467	A	-0.52	-0.54	-0.55	-0.53
13	2472	A	-0.63	-0.66	-0.65	-0.66

CHANNEL	FREQUENCY (MHz)	PEAK POWER (mW)	PEAK POWER (dBm)	LIMIT (dBm)	PASS / FAIL
1	2412	86.30	19.36	30	PASS
6	2437	124.74	20.96	30	PASS
11	2462	105.68	20.24	30	PASS
12	2467	0.89	-0.52	30	PASS
13	2472	0.86	-0.63	30	PASS

**802.11b\_Ant. B**

CHANNEL	FREQUENCY (MHz)	CHAIN	DATA RATE			
			1M bps	2M bps	5.5M bps	11M bps
1	2412	B	19.21	19.2	19.18	19.15
6	2437	B	20.62	20.57	20.58	20.54
11	2462	B	19.95	19.91	19.9	19.92
12	2467	B	0.06	0.04	0.05	0.03
13	2472	B	-0.02	-0.04	-0.03	-0.06

CHANNEL	FREQUENCY (MHz)	PEAK POWER (mW)	PEAK POWER (dBm)	LIMIT (dBm)	PASS / FAIL
1	2412	83.37	19.21	30	PASS
6	2437	115.35	20.62	30	PASS
11	2462	98.86	19.95	30	PASS
12	2467	1.01	0.06	30	PASS
13	2472	1.00	-0.02	30	PASS



A D T

### 802.11g\_Ant. A

CHANNEL	FREQUENCY (MHz)	CHAIN	DATA RATE							
			6M bps	9M bps	12M bps	18M bps	24M bps	36M bps	48M bps	54M bps
1	2412	A	15.96	15.95	15.94	15.91	15.88	15.93	15.91	15.9
6	2437	A	19.56	19.49	19.43	19.43	19.42	19.5	19.42	19.49
11	2462	A	15.65	15.57	15.52	15.53	15.47	15.52	15.57	15.55
12	2467	A	-0.25	-0.28	-0.3	-0.29	-0.26	-0.27	-0.26	-0.28
13	2472	A	-0.99	-1.02	-1.03	-1	-1.02	-1.01	-1.2	-1.03

CHANNEL	FREQUENCY (MHz)	PEAK POWER (mW)	PEAK POWER (dBm)	LIMIT (dBm)	PASS / FAIL
1	2412	39.45	15.96	30	PASS
6	2437	90.36	19.56	30	PASS
11	2462	36.73	15.65	30	PASS
12	2467	0.94	-0.25	30	PASS
13	2472	0.80	-0.99	30	PASS

### 802.11g\_Ant. B

CHANNEL	FREQUENCY (MHz)	CHAIN	DATA RATE							
			6M bps	9M bps	12M bps	18M bps	24M bps	36M bps	48M bps	54M bps
1	2412	B	15.57	15.54	15.52	15.49	15.47	15.41	15.5	15.43
6	2437	B	19.5	19.46	19.47	19.41	19.44	19.43	19.4	19.38
11	2462	B	15.4	15.36	15.3	15.32	15.33	15.34	15.3	15.29
12	2467	B	0.53	0.51	0.47	0.5	0.48	0.46	0.51	0.48
13	2472	B	0.14	0.1	0.11	0.09	0.12	0.1	0.13	0.08

CHANNEL	FREQUENCY (MHz)	PEAK POWER (mW)	PEAK POWER (dBm)	LIMIT (dBm)	PASS / FAIL
1	2412	36.06	15.57	30	PASS
6	2437	89.13	19.5	30	PASS
11	2462	34.67	15.4	30	PASS
12	2467	1.13	0.53	30	PASS
13	2472	1.03	0.14	30	PASS





A D T

**802.11n (20MHz)\_ Ant. A**

CHANNEL	FREQUENCY (MHz)	CHAIN	DATA RATE							
			MCS0	MCS1	MCS2	MCS3	MCS4	MCS5	MCS6	MCS7
1	2412	A	15.42	15.34	15.33	15.38	15.39	15.4	15.36	15.41
6	2437	A	19.2	19.13	19.14	19.11	19.18	19.15	19.12	19.16
11	2462	A	15.1	14.96	14.92	15.09	15.08	14.96	15.03	15.08
12	2467	A	-0.19	-0.23	-0.22	-0.2	-0.25	-0.21	-0.23	-0.22
13	2472	A	-0.24	-0.26	-0.25	-0.27	-0.28	-0.25	-0.26	-0.25

CHANNEL	FREQUENCY (MHz)	PEAK POWER (mW)	PEAK POWER (dBm)	LIMIT (dBm)	PASS / FAIL
1	2412	34.83	15.42	30	PASS
6	2437	83.18	19.2	30	PASS
11	2462	32.36	15.1	30	PASS
12	2467	0.96	-0.19	30	PASS
13	2472	0.95	-0.24	30	PASS

**802.11n (20MHz)\_ Ant. B**

CHANNEL	FREQUENCY (MHz)	CHAIN	DATA RATE							
			MCS0	MCS1	MCS2	MCS3	MCS4	MCS5	MCS6	MCS7
1	2412	B	15.04	15.02	14.98	15	14.96	14.95	14.91	14.93
6	2437	B	18.86	18.84	18.84	18.82	18.77	18.76	18.8	18.75
11	2462	B	14.75	14.74	14.74	14.73	14.71	14.65	14.69	14.66
12	2467	B	0.51	0.5	0.49	0.48	0.47	0.49	0.47	0.5
13	2472	B	0.64	0.63	0.62	0.6	0.62	0.61	0.59	0.62

CHANNEL	FREQUENCY (MHz)	PEAK POWER (mW)	PEAK POWER (dBm)	LIMIT (dBm)	PASS / FAIL
1	2412	31.92	15.04	30	PASS
6	2437	76.91	18.86	30	PASS
11	2462	29.85	14.75	30	PASS
12	2467	1.12	0.51	30	PASS
13	2472	1.16	0.64	30	PASS

## 4.5 POWER SPECTRAL DENSITY MEASUREMENT

### 4.5.1 LIMITS OF POWER SPECTRAL DENSITY MEASUREMENT

The Maximum of Power Spectral Density Measurement is 8dBm.

### 4.5.2 TEST SETUP

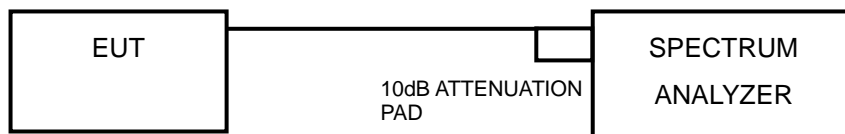

### 4.5.3 TEST INSTRUMENTS

Refer to section 4.1.2 to get information of above instrument.

### 4.5.4 TEST PROCEDURE

- Set the RBW = 3 kHz, VBW =10 kHz, Detector = peak.
- Sweep time = auto couple, Trace mode = max hold, allow trace to fully stabilize.
- Use the peak marker function to determine the maximum power level in any 100 kHz band segment within the fundamental EBW.

### 4.5.5 DEVIATION FROM TEST STANDARD

No deviation.

### 4.5.6 EUT OPERATING CONDITION

Same as section 4.3.6.



### 4.5.7 TEST RESULTS

#### Mode A

##### 802.11b

CHANNEL	FREQUENCY (MHz)	PSD (dBm/3kHz)	LIMIT (dBm/3kHz)	PASS / FAIL
1	2412	-2.94	8	PASS
6	2437	-2.56	8	PASS
11	2462	-2.71	8	PASS

##### 802.11g

CHANNEL	FREQUENCY (MHz)	PSD (dBm/3kHz)	LIMIT (dBm/3kHz)	PASS / FAIL
1	2412	-7.62	8	PASS
6	2437	-5.36	8	PASS
11	2462	-7.31	8	PASS

##### 802.11n (20MHz)

CHANNEL	FREQUENCY (MHz)	PSD (dBm/3kHz)	LIMIT (dBm/3kHz)	PASS / FAIL
1	2412	-9.22	8	PASS
6	2437	-5.24	8	PASS
11	2462	-9.58	8	PASS



A D T

### SPECTRUM PLOT OF WORST VALUE

#### 802.11b

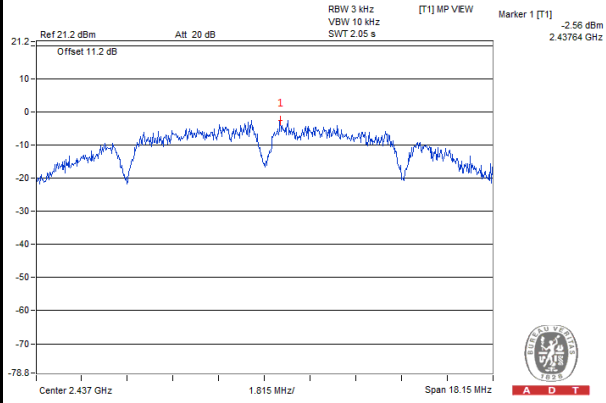

#### 802.11g

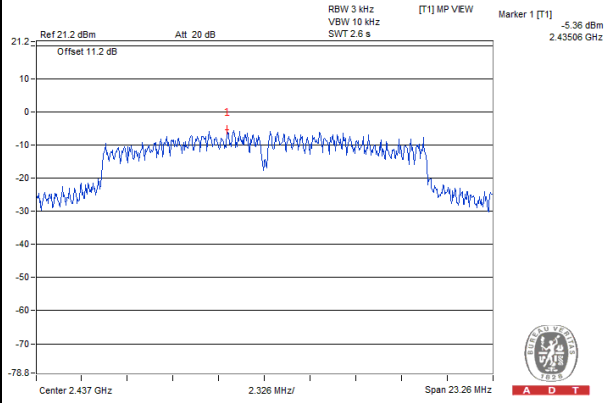

#### 802.11n (20MHz)

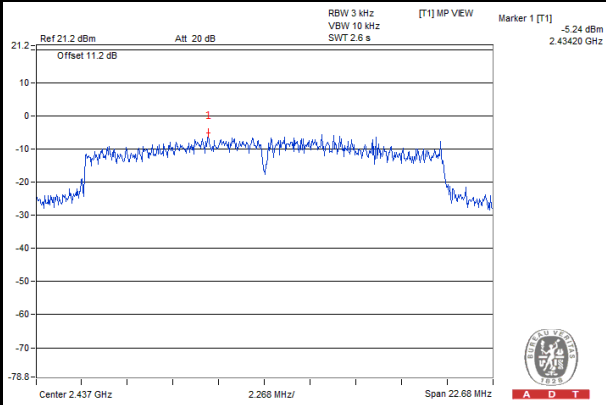



A D T

**Mode B**

**802.11b**

CHANNEL	FREQUENCY (MHz)	PSD (dBm/3kHz)	LIMIT (dBm/3kHz)	PASS / FAIL
1	2412	-3.03	8	PASS
6	2437	-2.96	8	PASS
11	2462	-3.55	8	PASS

**802.11g**

CHANNEL	FREQUENCY (MHz)	PSD (dBm/3kHz)	LIMIT (dBm/3kHz)	PASS / FAIL
1	2412	-8.83	8	PASS
6	2437	-5.27	8	PASS
11	2462	-7.10	8	PASS

**802.11n (20MHz)**

CHANNEL	FREQUENCY (MHz)	PSD (dBm/3kHz)	LIMIT (dBm/3kHz)	PASS / FAIL
1	2412	-9.58	8	PASS
6	2437	-4.54	8	PASS
11	2462	-10.13	8	PASS



A D T

### SPECTRUM PLOT OF WORST VALUE

#### 802.11b

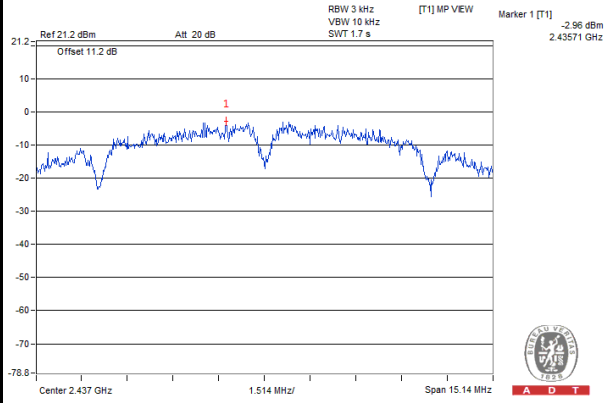

#### 802.11g

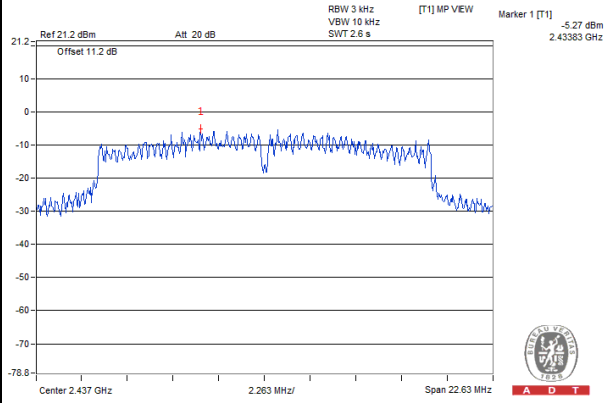

#### 802.11n (20MHz)

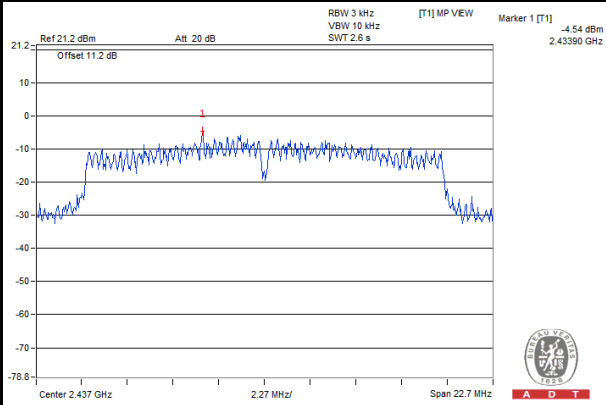

## 4.6 CONDUCTED OUT OF BAND EMISSION MEASUREMENT

### 4.6.1 LIMITS OF CONDUCTED OUT OF BAND EMISSION MEASUREMENT

Below  $-20\text{dB}$  of the highest emission level of operating band (in 100kHz Resolution Bandwidth).

### 4.6.2 TEST SETUP

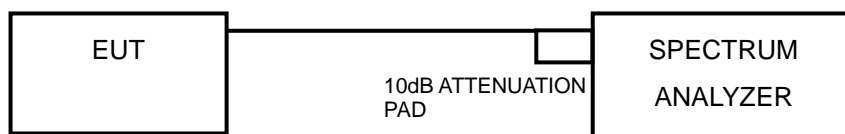

### 4.6.3 TEST INSTRUMENTS

Refer to section 4.1.2 to get information of above instrument.

### 4.6.4 TEST PROCEDURE

#### MEASUREMENT PROCEDURE REF

1. Set the RBW = 100 kHz.
2. Set the VBW  $\geq$  300 kHz.
3. Detector = peak.
4. Sweep time = auto couple.
5. Trace mode = max hold.
6. Allow trace to fully stabilize.
7. Use the peak marker function to determine the maximum power level in any 100 kHz band segment within the fundamental EBW.

#### MEASUREMENT PROCEDURE OOB

1. Set RBW = 100 kHz.
2. Set VBW  $\geq$  300 kHz.
3. Detector = peak.
4. Sweep = auto couple.
5. Trace Mode = max hold.
6. Allow trace to fully stabilize.
7. Use the peak marker function to determine the maximum amplitude level.

### 4.6.5 DEVIATION FROM TEST STANDARD

No deviation.

### 4.6.6 EUT OPERATING CONDITION

Same as section 4.3.6.



A D T

### 4.6.7 TEST RESULTS

The spectrum plots are attached on the following images. D1 line indicates the highest level, and D2 line indicates the 20dB offset below D1. It shows compliance with the requirement.

#### Mode A

#### 802.11b

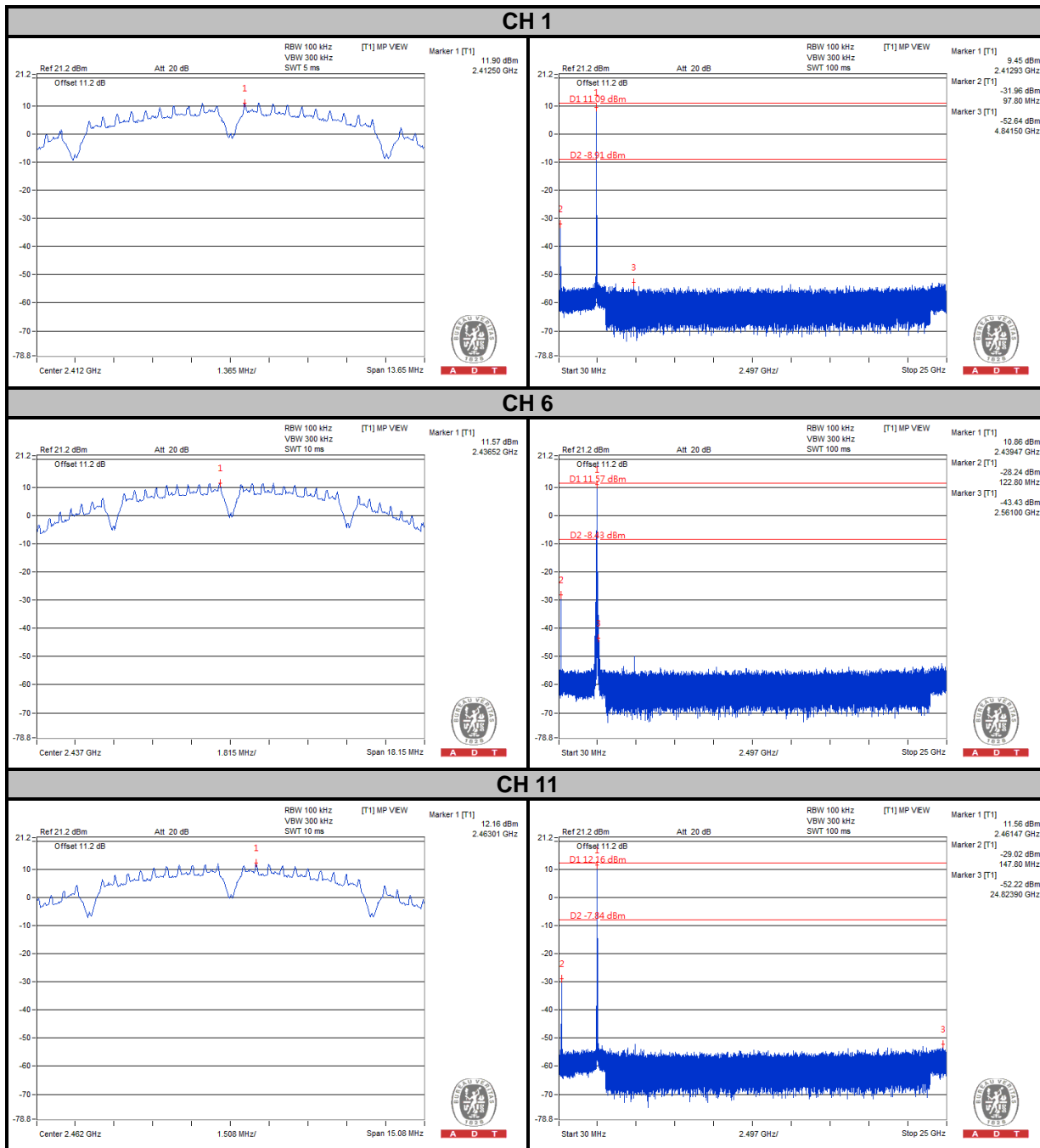





A D T

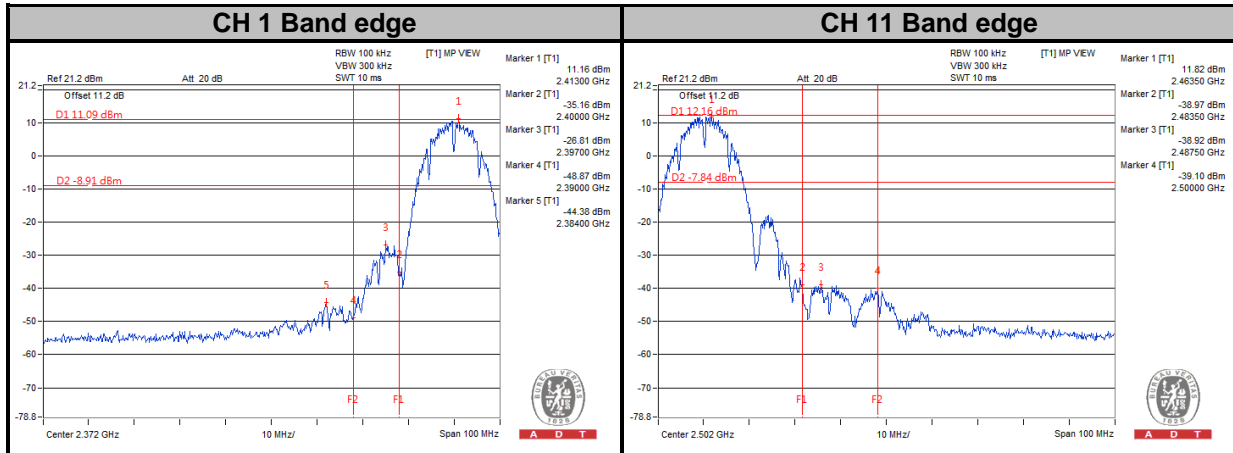



A D T

### 802.11g

#### CH 1

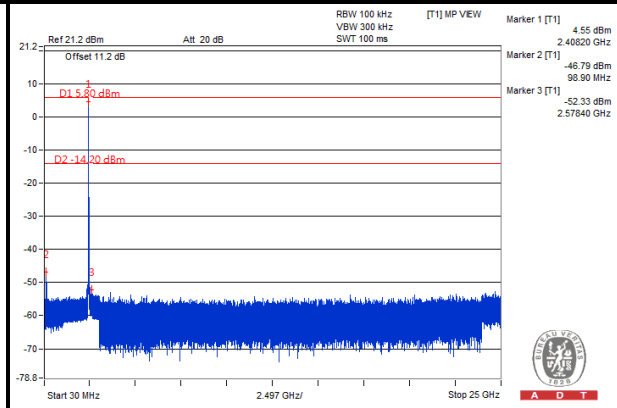
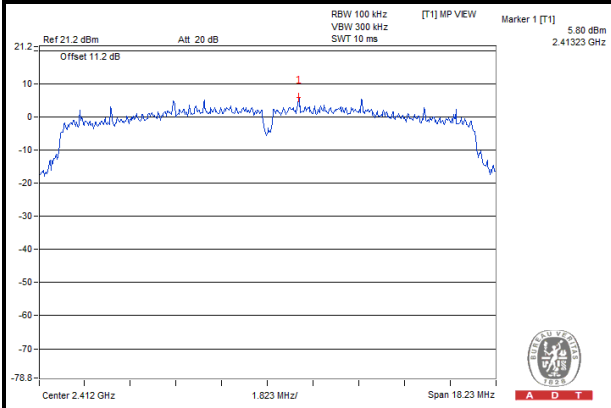

#### CH 6

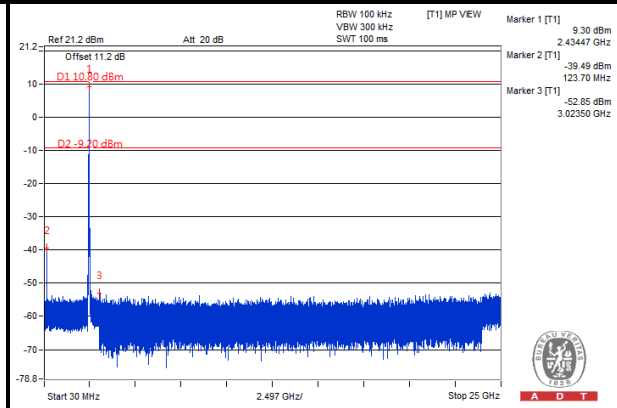
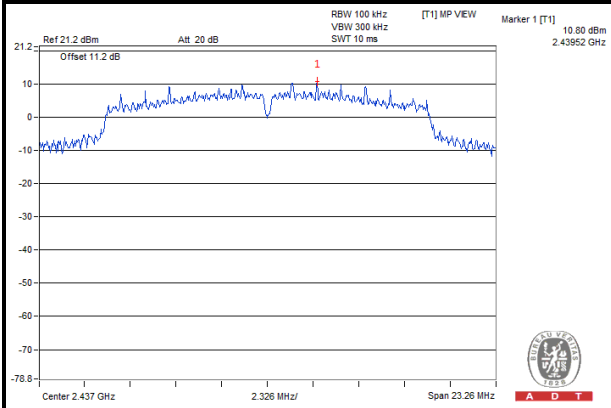

#### CH 11

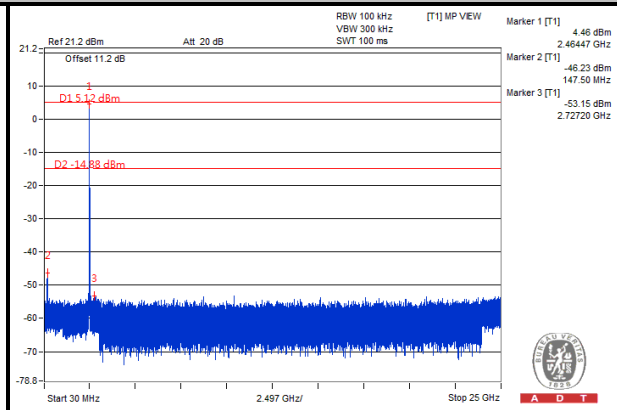
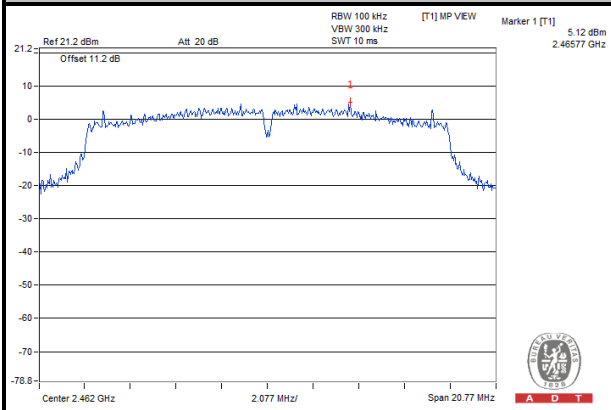



A D T

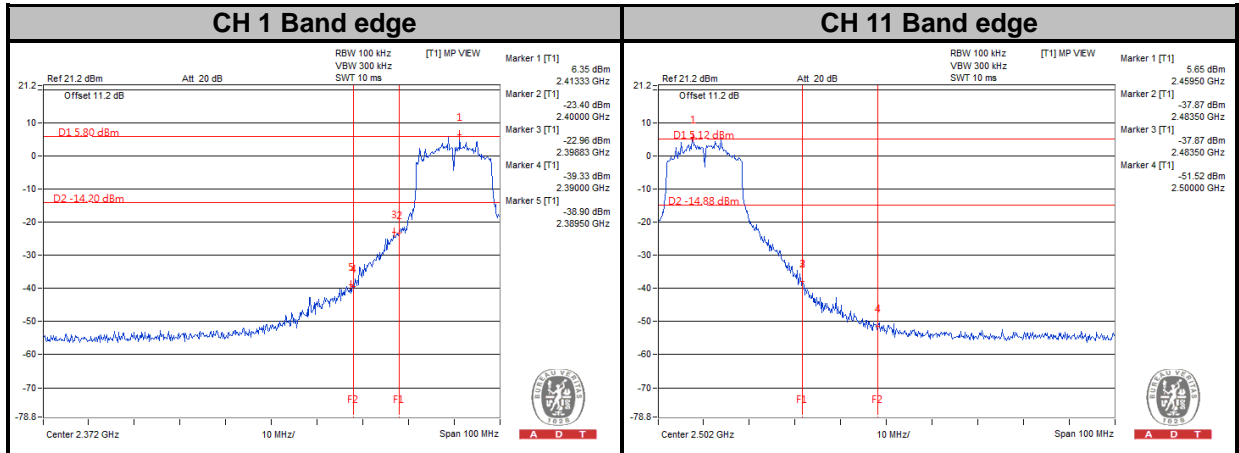



A D T

### 802.11n (20MHz)

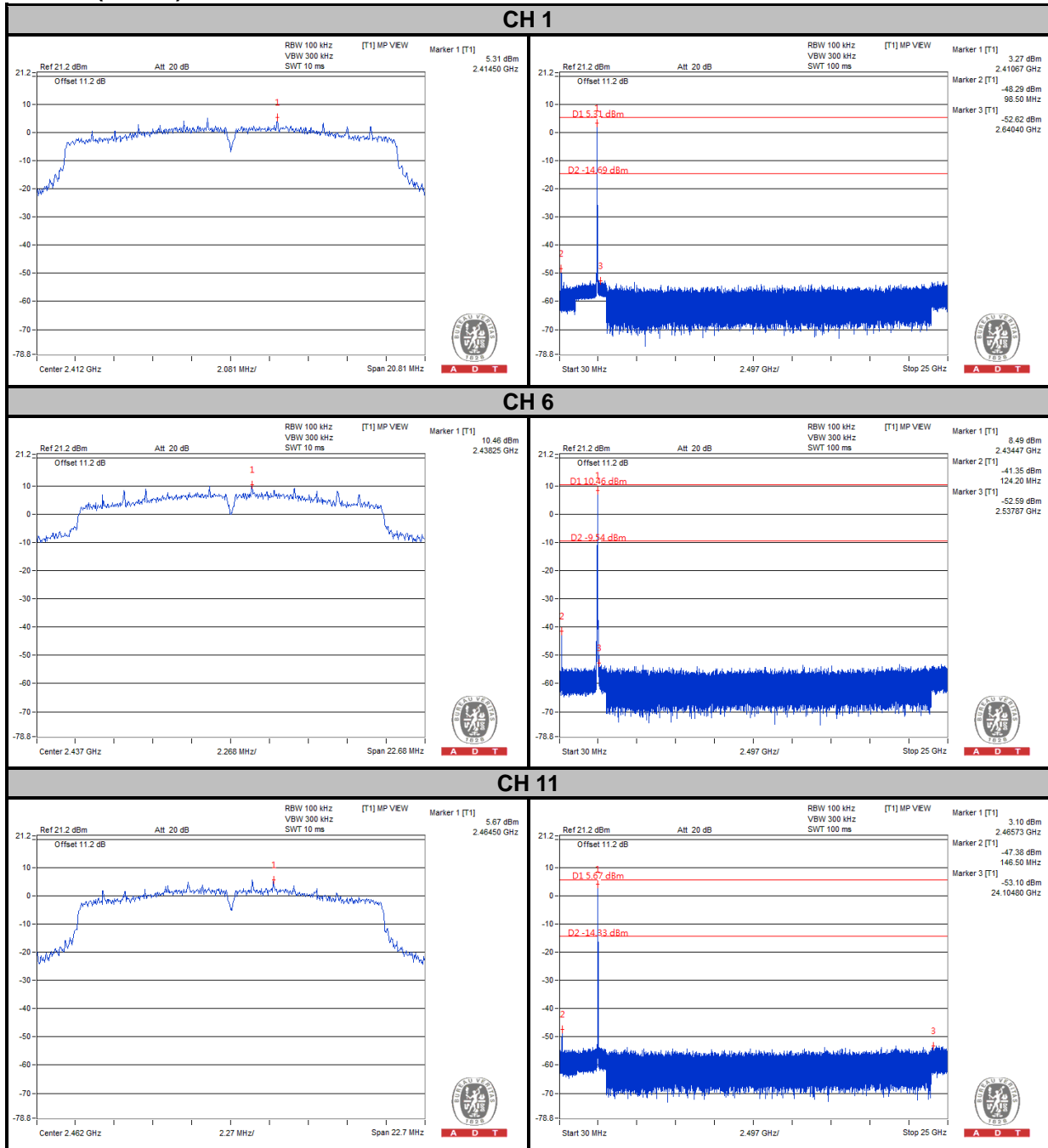



A D T

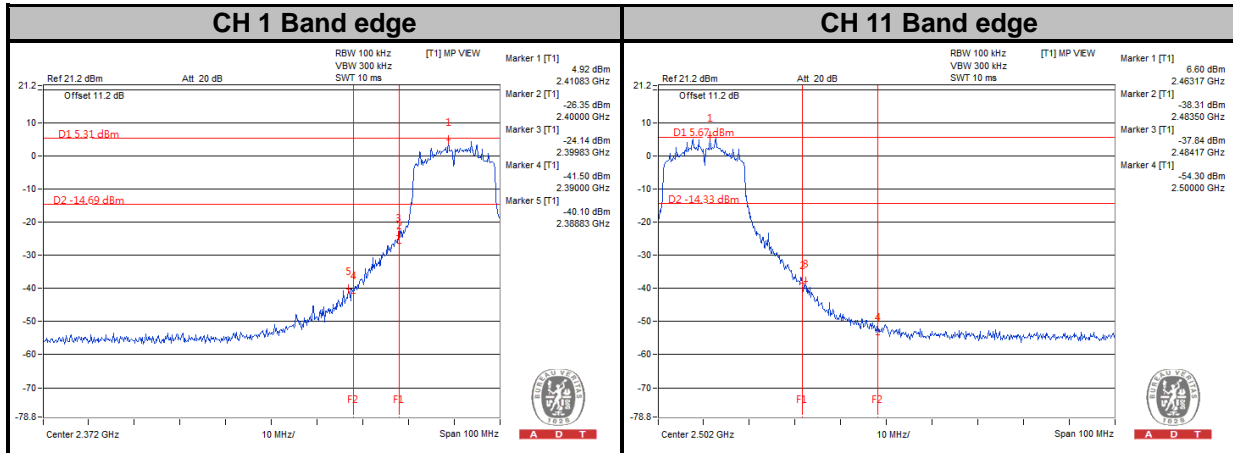



A D T

# Mode B

## 802.11b

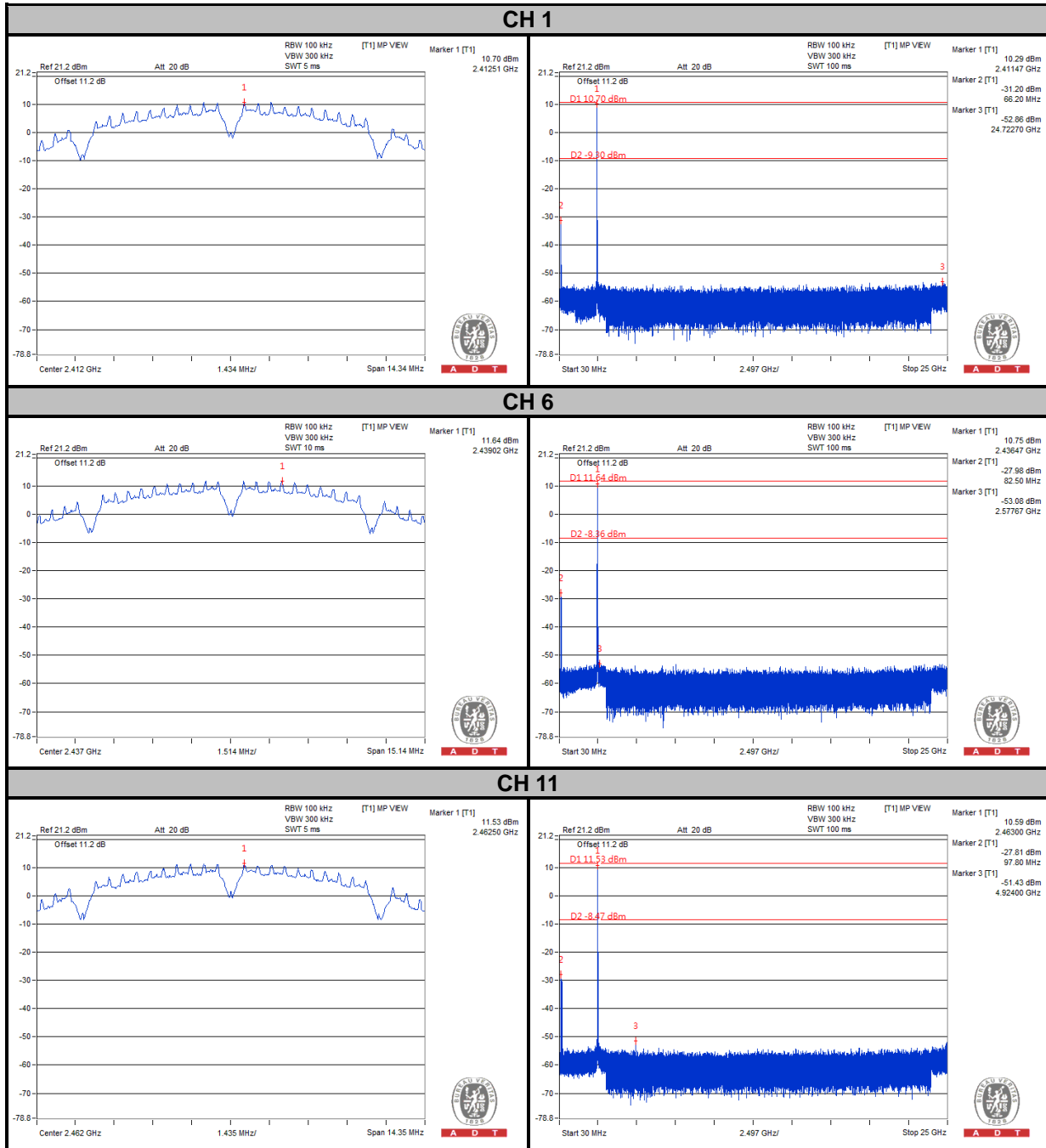



A D T

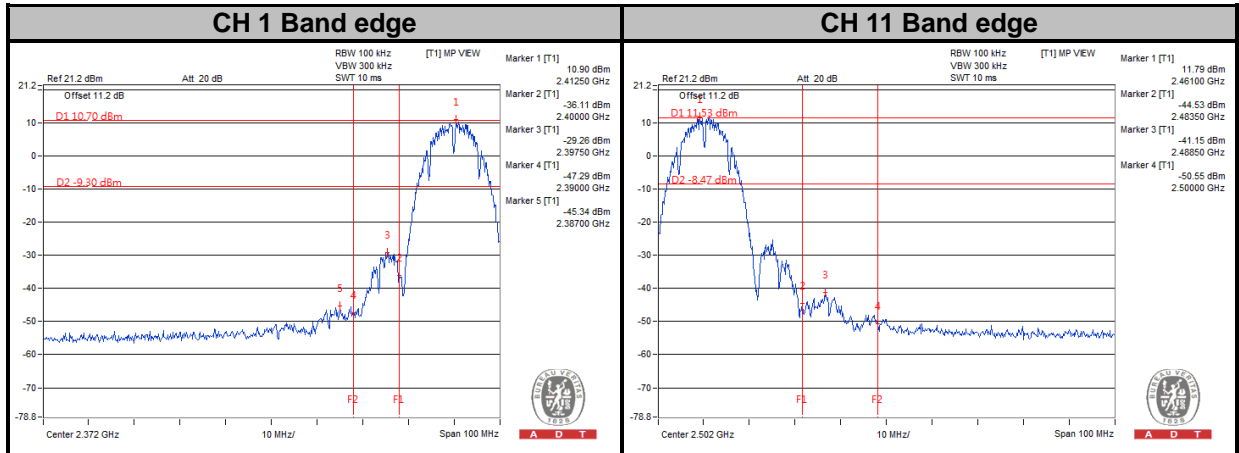



A D T

### 802.11g

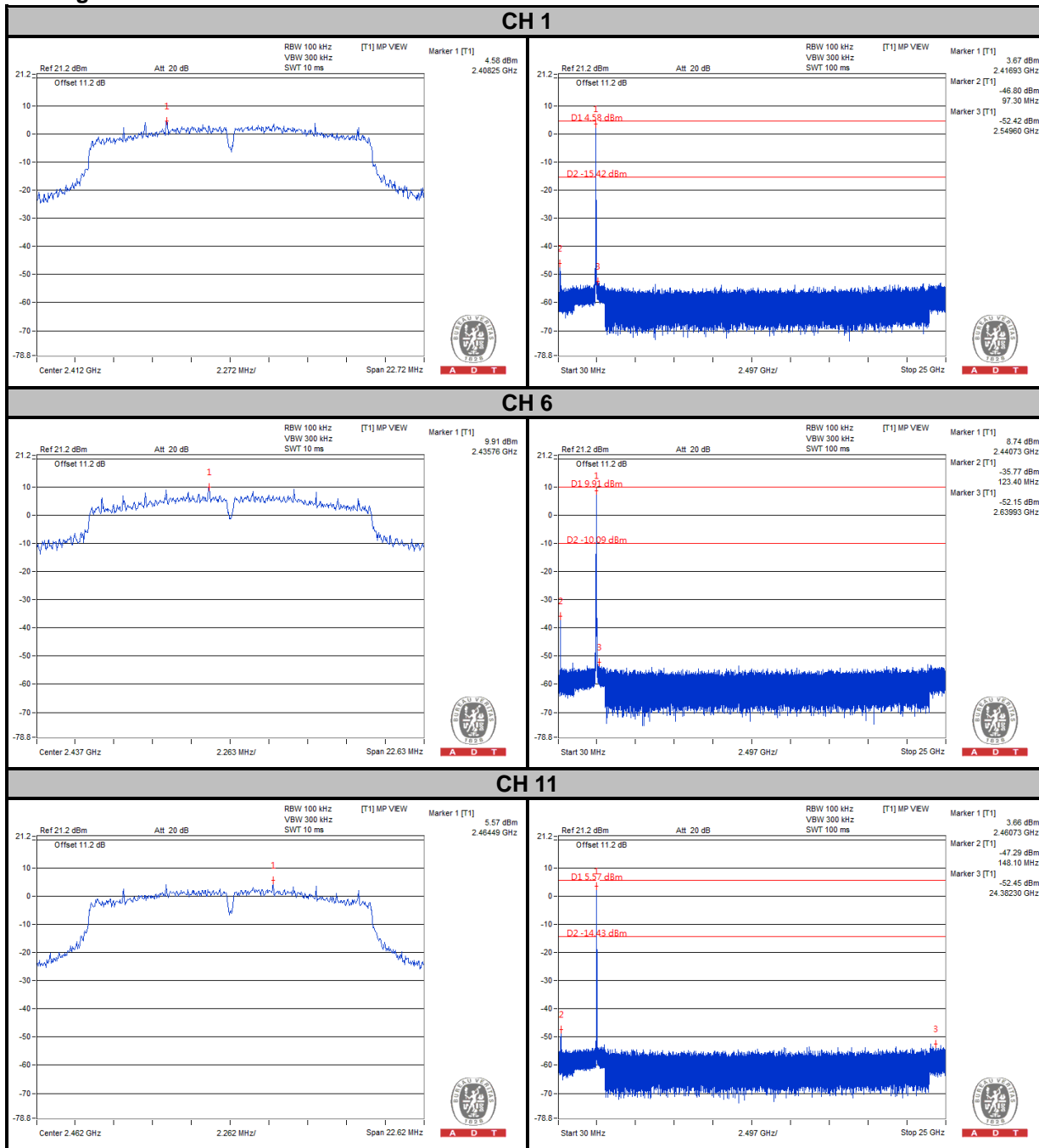





A D T

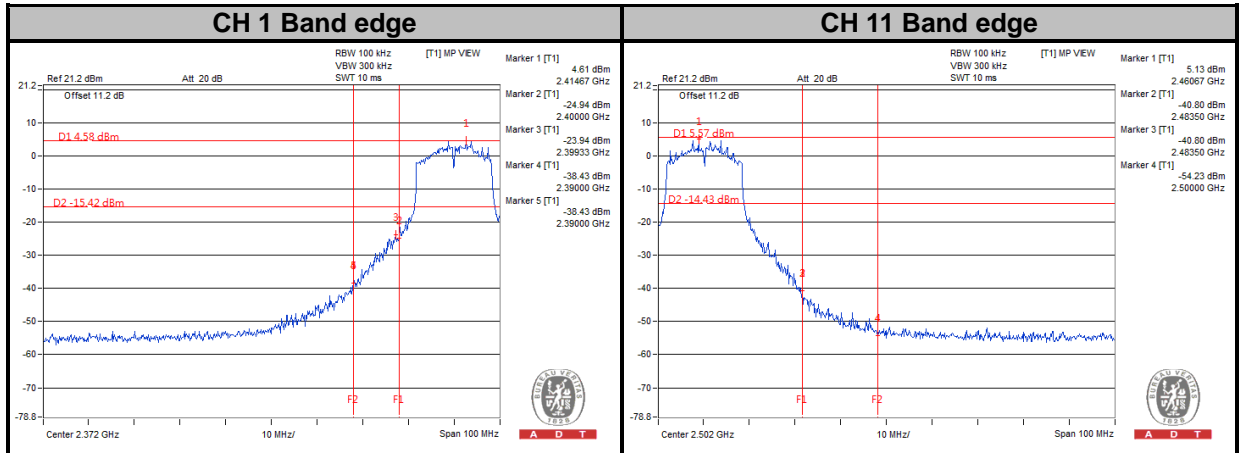



A D T

### 802.11n (20MHz)

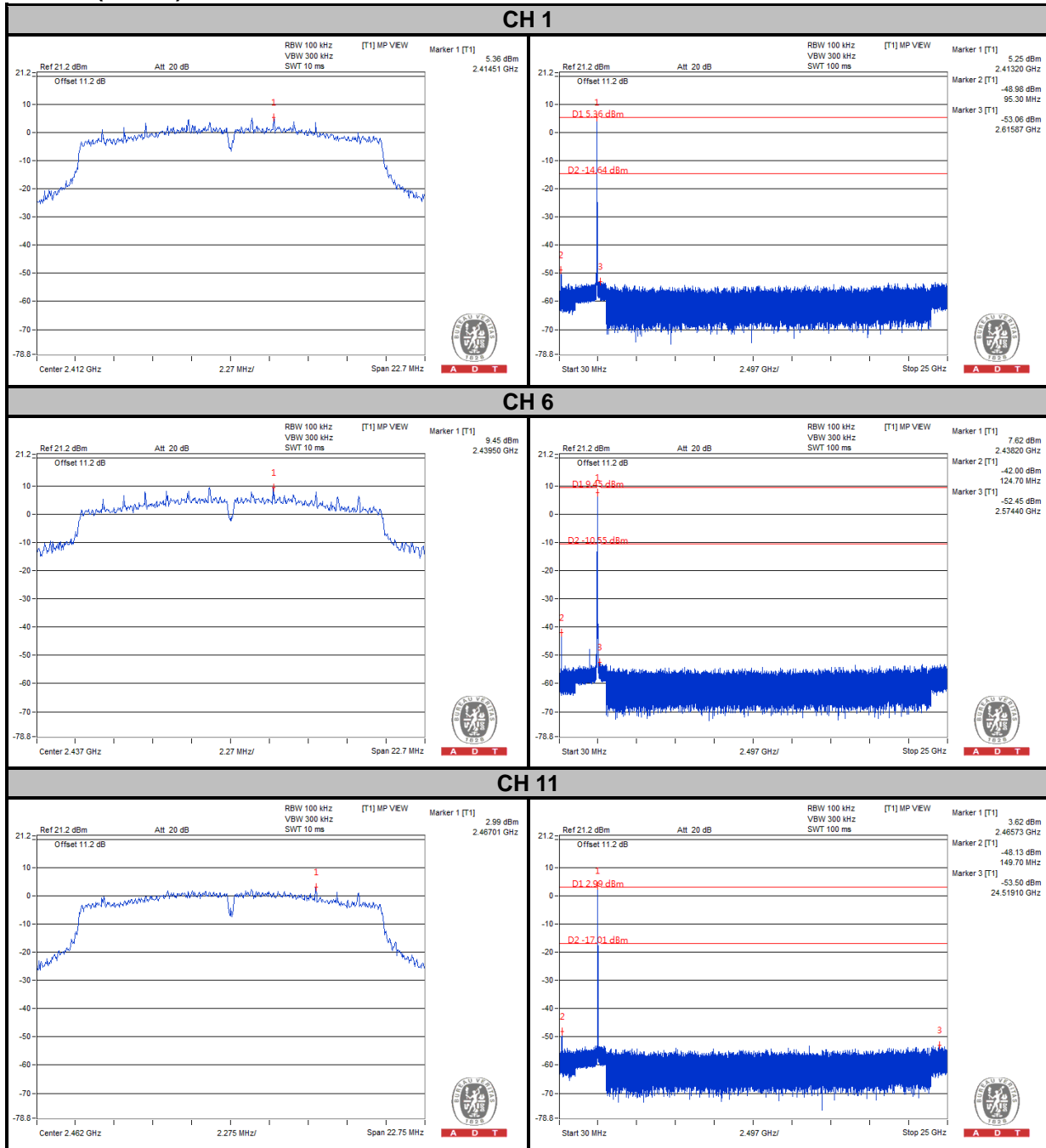



A D T

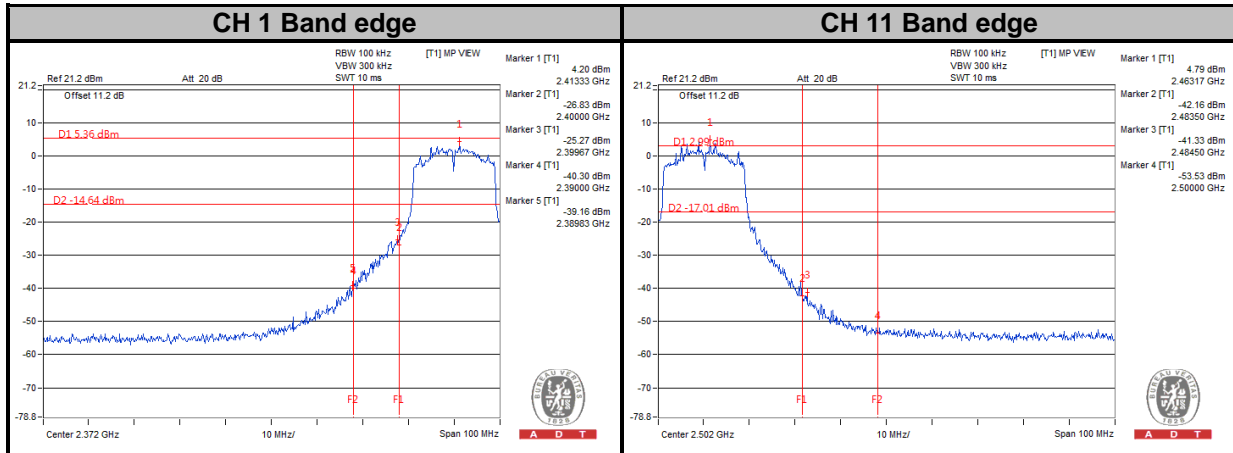



A D T

## 5. PHOTOGRAPHS OF THE TEST CONFIGURATION

Please refer to the attached file (Test Setup Photo).



## 6. INFORMATION ON THE TESTING LABORATORIES

We, Bureau Veritas Consumer Products Services (H.K.) Ltd., Taoyuan Branch, were founded in 1988 to provide our best service in EMC, Radio, Telecom and Safety consultation. Our laboratories are accredited and approved according to ISO/IEC 17025.

If you have any comments, please feel free to contact us at the following:

**Linko EMC/RF Lab:**

Tel: 886-2-26052180

Fax: 886-2-26051924

**Hsin Chu EMC/RF/Telecom Lab:**

Tel: 886-3-5935343

Fax: 886-3-5935342

**Hwa Ya EMC/RF/Safety Lab:**

Tel: 886-3-3183232

Fax: 886-3-3270892

**Email:** [service.adt@tw.bureauveritas.com](mailto:service.adt@tw.bureauveritas.com)

**Web Site:** [www.bureauveritas-adt.com](http://www.bureauveritas-adt.com)

The address and road map of all our labs can be found in our web site also.



A D T

## 7. APPENDIX A – MODIFICATIONS RECORDERS FOR ENGINEERING CHANGES TO THE EUT BY THE LAB

No any modifications are made to the EUT by the lab during the test.

---END---