



SUPPLEMENTARY FCC TEST REPORT (15.407)

REPORT NO.: RF120903C21S-3
MODEL NO.: MC40N0
FCC ID: UZ7MC40N0
RECEIVED: Mar. 23, 2015
TESTED: Mar. 26, 2015 ~ Apr. 16, 2015
ISSUED: Jun. 05, 2015

APPLICANT: Zebra Technologies Corporation

ADDRESS: 1 Zebra Plaza, Holtsville, NY 11742

ISSUED BY: Bureau Veritas Consumer Products Services
(H.K.) Ltd., Taoyuan Branch

LAB ADDRESS: No. 47-2, 14th Ling, Chia Pau Vil., Lin Kou Dist.,
New Taipei City, Taiwan (R.O.C)

TEST LOCATION: No. 19, Hwa Ya 2nd Rd, Wen Hwa Vil., Kwei
Shan Dist., Taoyuan City 33383, Taiwan (R.O.C.)

This report should not be used by the client to claim product certification, approval, or endorsement by TAF or any government agencies.



This report is for your exclusive use. Any copying or replication of this report to or for any other person or entity, or use of our name or trademark, is permitted only with our prior written permission. This report sets forth our findings solely with respect to the test samples identified herein. The results set forth in this report are not indicative or representative of the quality or characteristics of the lot from which a test sample was taken or any similar or identical product unless specifically and expressly noted. Our report includes all of the tests requested by you and the results thereof based upon the information that you provided to us. You have 60 days from date of issuance of this report to notify us of any material error or omission caused by our negligence, provided, however, that such notice shall be in writing and shall specifically address the issue you wish to raise. A failure to raise such issue within the prescribed time shall constitute your unqualified acceptance of the completeness of this report, the tests conducted and the correctness of the report contents. Unless specific mention, the uncertainty of measurement has been explicitly taken into account to declare the compliance or non-compliance to the specification.



TABLE OF CONTENTS

REPORT ISSUE HISTORY RECORD	4
RELEASE CONTROL RECORD	5
1. CERTIFICATION.....	6
2. SUMMARY OF TEST RESULTS	7
2.1 MEASUREMENT UNCERTAINTY.....	7
3. GENERAL INFORMATION	8
3.1 GENERAL DESCRIPTION OF EUT	8
3.2 DESCRIPTION OF TEST MODES	10
3.2.1 TEST MODE APPLICABILITY AND TESTED CHANNEL DETAIL.....	11
3.3 DESCRIPTION OF SUPPORT UNITS	14
3.3.1 CONFIGURATION OF SYSTEM UNDER TEST	14
3.4 DUTY CYCLE TEST SIGNAL.....	15
3.5 GENERAL DESCRIPTION OF APPLIED STANDARDS	21
4. TEST TYPES AND RESULTS	22
4.1 RADIATED EMISSION AND BANDEDGE MEASUREMENT	22
4.1.1 LIMITS OF RADIATED EMISSION AND BANDEDGE MEASUREMENT	22
4.1.2 LIMITS OF UNWANTED EMISSION OUT OF THE RESTRICTED BANDS	22
4.1.3 TEST INSTRUMENTS.....	23
4.1.4 TEST PROCEDURES	24
4.1.5 DEVIATION FROM TEST STANDARD	24
4.1.6 TEST SETUP	25
4.1.7 EUT OPERATING CONDITIONS	25
4.1.8 TEST RESULTS.....	26
4.2 CONDUCTED EMISSION MEASUREMENT	130
4.2.1 LIMITS OF CONDUCTED EMISSION MEASUREMENT	130
4.2.2 TEST INSTRUMENTS.....	130
4.2.3 TEST PROCEDURES	131
4.2.4 DEVIATION FROM TEST STANDARD	131
4.2.5 TEST SETUP	132
4.2.6 EUT OPERATING CONDITIONS	132
4.2.7 TEST RESULTS.....	133
4.3 TRANSMIT POWER MEASUREMENT	137
4.3.1 LIMITS OF TRANSMIT POWER MEASUREMENT	137
4.3.2 TEST SETUP	137
4.3.3 TEST INSTRUMENTS.....	137
4.3.4 TEST PROCEDURE	138
4.3.5 DEVIATION FROM TEST STANDARD	138
4.3.6 EUT OPERATING CONDITIONS	138
4.3.7 TEST RESULTS.....	139
4.4 PEAK POWER SPECTRAL DENSITY MEASUREMENT	157
4.4.1 LIMITS OF PEAK POWER SPECTRAL DENSITY MEASUREMENT	157
4.4.2 TEST SETUP	157
4.4.3 TEST INSTRUMENTS.....	157
4.4.4 TEST PROCEDURES	157
4.4.5 DEVIATION FROM TEST STANDARD	158
4.4.6 EUT OPERATING CONDITIONS	158
4.4.7 TEST RESULTS.....	159
4.5 FREQUENCY STABILITY	165
4.5.1 LIMITS OF FREQUENCY STABILITY MEASUREMENT	165
4.5.2 TEST SETUP	165
4.5.3 TEST INSTRUMENTS.....	165



A D T

4.5.4	TEST PROCEDURE	166
4.5.5	DEVIATION FROM TEST STANDARD	166
4.5.6	EUT OPERATING CONDITION.....	166
4.5.7	TEST RESULTS.....	167
4.6	6dB BANDWIDTH MEASUREMENT	171
4.6.1	LIMITS OF 6dB BANDWIDTH MEASUREMENT	171
4.6.2	TEST SETUP	171
4.6.3	TEST INSTRUMENTS	171
4.6.4	TEST PROCEDURE	171
4.6.5	DEVIATION FROM TEST STANDARD	171
4.6.6	EUT OPERATING CONDITIONS	171
4.6.7	TEST RESULTS.....	172
5.	PHOTOGRAPHS OF THE TEST CONFIGURATION.....	174
6.	INFORMATION ON THE TESTING LABORATORIES	175
7.	APPENDIX A - MODIFICATIONS RECORDERS FOR ENGINEERING CHANGES TO THE EUT BY THE LAB	176



A D T

REPORT ISSUE HISTORY RECORD

ISSUE NO.	REASON FOR CHANGE	DATE ISSUED
1	Original release	Sep. 17, 2012
2	1. New LCM, TP, Scanner engine, larger speaker and MIC 2. New antenna design (WLAN1, WLAN2) and new antenna location (WLAN2, BT) 3. New Schematic, Block Diagram 4. Update SW and HW	Jun. 05, 2015



A D T

RELEASE CONTROL RECORD

ISSUE NO.	REASON FOR CHANGE	DATE ISSUED
RF120903C21S-3	Original release	Jun. 05, 2015

1. CERTIFICATION

PRODUCT: Mobile Computer
MODEL NO.: MC40N0
BRAND: Symbol
APPLICANT: Zebra Technologies Corporation
TESTED: Mar. 26, 2015 ~ Apr. 16, 2015
TEST SAMPLE: Engineering Sample
STANDARDS: **FCC Part 15, Subpart E (Section 15.407)**
ANSI C63.10-2013

The above equipment (model: MC40N0) has been tested by **Bureau Veritas Consumer Products Services (H.K.) Ltd., Taoyuan Branch**, and found compliance with the requirement of the above standards. The test record, data evaluation & Equipment Under Test (EUT) configurations represented herein are true and accurate accounts of the measurements of the sample's EMC characteristics under the conditions specified in this report.

PREPARED BY : Rona Chen , **DATE** : Jun. 05, 2015
Rona Chen / Specialist

APPROVED BY : Sam chen , **DATE** : Jun. 05, 2015
Sam Chen / Senior Project Engineer

2. SUMMARY OF TEST RESULTS

The EUT has been tested according to the following specifications:

APPLIED STANDARD: FCC PART 15, SUBPART E (SECTION 15.407)			
STANDARD SECTION	TEST TYPE	RESULT	REMARK
15.407(b)(6)	AC Power Conducted Emission	PASS	Meet the requirement of limit. Minimum passing margin is -7.78dB at 0.37304MHz.
15.407(b/1/2/3) (b)(6)	Radiated Emissions	PASS	Meet the requirement of limit. Minimum passing margin is -1.07dB at 5320MHz.
15.407(a/1/2/3)	Max Average Transmit Power	PASS	Meet the requirement of limit.
15.407(a/1/2/3)	Peak Power Spectral Density	PASS	Meet the requirement of limit.
15.407(e)	6dB bandwidth	PASS	Meet the requirement of limit. (U-NII-3 Band only)
15.407(g)	Frequency Stability	PASS	Meet the requirement of limit.
15.203	Antenna Requirement	PASS	No antenna connector is used.

2.1 MEASUREMENT UNCERTAINTY

Where relevant, the following measurement uncertainty levels have been estimated for tests performed on the EUT as specified in CISPR 16-4-2:

MEASUREMENT	FREQUENCY	UNCERTAINTY
Conducted emissions	9kHz~30MHz	2.44 dB
Radiated emissions	30MHz ~ 200MHz	2.93 dB
	200MHz ~1000MHz	2.95 dB
	1GHz ~ 18GHz	2.26 dB
	18GHz ~ 40GHz	1.94 dB

This uncertainty represents an expanded uncertainty expressed at approximately the 95% confidence level using a coverage factor of $k = 2$.

3. GENERAL INFORMATION

3.1 GENERAL DESCRIPTION OF EUT

EUT	Mobile Computer
MODEL NO.	MC40N0
POWER SUPPLY	5Vdc (adapter or host equipment) 3.7Vdc (Li-ion battery)
MODULATION TYPE	64QAM, 16QAM, QPSK, BPSK
MODULATION TECHNOLOGY	OFDM
TRANSFER RATE	802.11a: 54.0/ 48.0/ 36.0/ 24.0/ 18.0/ 12.0/ 9.0/ 6.0Mbps 802.11n: up to MCS7
OPERATING FREQUENCY	5180 ~ 5240MHz, 5260 ~ 5320MHz, 5500 ~ 5700MHz, 5745 ~ 5825MHz
NUMBER OF CHANNEL	5180 ~ 5240MHz: 4 for 802.11a, 802.11n (20MHz) 5260 ~ 5320MHz: 4 for 802.11a, 802.11n (20MHz) 5500 ~ 5700MHz: 11 for 802.11a, 802.11n (20MHz) 5745 ~ 5825MHz: 5 for 802.11a, 802.11n (20MHz)
OUTPUT POWER	69.82mW for 5180 ~ 5240MHz 78.52mW for 5260 ~ 5320MHz 81.47mW for 5500 ~ 5700MHz 73.11mW for 5745 ~ 5825MHz
ANTENNA TYPE	Refer to Note as below
ANTENNA CONNECTOR	NA
DATA CABLE	Refer to Note as below
I/O PORTS	Refer to user's manual
ACCESSORY DEVICES	Refer to Note as below
HW VERSION	EV2
SW VERSION	Android version: 4.4.4 Build number: 99-4AJ22-K-0008-0004-V0-M1-031315

NOTE:

1. This report is issued as a supplementary report of BV ADT report no.: RF120903C21-1. For more detail of difference compared with original report, please refer to issued no. 5 of "report issue history record" on page 4. Therefore, all items had been performed and presented in the test report.
2. The device is available with or without MSR.
3. Antenna gain is listed as table below.

Configuration	Antenna type	Main antenna gain (dBi)				AUX antenna gain (dBi)			
		Band 1	Band 2	Band 3	Band 4	Band 1	Band 2	Band 3	Band 4
With MSR	PIFA	2.4	3.2	1.8	1.5	4.4	4.1	4.5	3.9
Without MSR		2.5	3.1	3.1	3.1	3.9	3.9	3.1	3.6



A D T

4. The following accessories are optional.

ITEM	BRAND	MODEL	SPECIFICATION
Adapter	Motorola / Symbol	IU08-2050120-WP	I/P: 100-240Vac, 50/60Hz, 0.2A O/P: 5Vdc, 1.2A
Earphone 1	Symbol / Zebra	NA	1.3m non-shielded cable w/o core
Earphone 2	Symbol / Zebra	21-UNIV-HDSET1-01 R	1.2m non-shielded cable w/o core
Micro USB Cable	Symbol / Zebra	25-MCXUSB-01R	1.5m shielded cable w/o core
Holster	Symbol / Zebra	SG-MC40HLSTR-03R	--
Handstrap	Symbol / Zebra	SG-MC40Strap-10R	--

5. The EUT uses following battery.

Brand	Symbol / Zebra
Rating	3.7Vdc

6. The EUT incorporates a MIMO function. Physically, the EUT provides 1 completed transmitter and 2 receivers.

MODULATION MODE	TX FUNCTION
802.11a	1TX
802.11n (20MHz)	1TX

7. The above EUT information is declared by the manufacturer and for more detailed features description, please refer to the manufacturer's specifications or User's Manual.

3.2 DESCRIPTION OF TEST MODES

WLAN 5180 ~ 5240MHz

4 channels are provided for 802.11a, 802.11n (20MHz):

CHANNEL	FREQUENCY	CHANNEL	FREQUENCY
36	5180 MHz	44	5220 MHz
40	5200 MHz	48	5240 MHz

WLAN 5260 ~ 5320MHz

4 channels are provided for 802.11a, 802.11n (20MHz):

CHANNEL	FREQUENCY	CHANNEL	FREQUENCY
52	5260 MHz	60	5300 MHz
56	5280 MHz	64	5320 MHz

WLAN 5500 ~ 5700MHz

11 channels are provided for 802.11a, 802.11n (20MHz):

CHANNEL	FREQUENCY	CHANNEL	FREQUENCY
100	5500MHz	124	5620MHz
104	5520MHz	128	5640MHz
108	5540MHz	132	5660MHz
112	5560MHz	136	5680MHz
116	5580MHz	140	5700MHz
120	5600MHz		

WLAN 5745 ~ 5825MHz

5 channels are provided for 802.11a, 802.11n (20MHz):

CHANNEL	FREQUENCY	CHANNEL	FREQUENCY
149	5745MHz	161	5805MHz
153	5765MHz	165	5825MHz
157	5785MHz		



3.2.1 TEST MODE APPLICABILITY AND TESTED CHANNEL DETAIL

EUT CONFIGURE MODE	APPLICABLE TO				DESCRIPTION
	RE \geq 1G	RE $<$ 1G	PLC	APCM	
A	√	√	√	√	With MSR SKU
B	√	√	√	√	Without MSR SKU

Where **RE \geq 1G**: Radiated Emission above 1GHz **RE $<$ 1G**: Radiated Emission below 1GHz
PLC: Power Line Conducted Emission **APCM**: Antenna Port Conducted Measurement

NOTE: The EUT had been pre-tested on the positioned of each 3 axis. The worst case was found when positioned on **Y-plane for Mode A for Band 3 and Z-plane for Mode A for Band 1, Band 2, Band 4 and Mode B.**

RADIATED EMISSION TEST (ABOVE 1GHz):

Pre-Scan has been conducted to determine the worst-case mode from all possible combinations between available modulations, data rates and antenna ports (if EUT with antenna diversity architecture).

Following channel(s) was (were) selected for the final test as listed below.

EUT CONFIGURE MODE	MODE	FREQ. BAND (MHz)	AVAILABLE CHANNEL	TESTED CHANNEL	MODULATION TECHNOLOGY	MODULATION TYPE	DATA RATE (Mbps)
A, B	802.11a	5180-5240	36 to 48	36, 44, 48	OFDM	BPSK	6.0
	802.11n (20MHz)		36 to 48	36, 44, 48	OFDM	BPSK	MCS0
A, B	802.11a	5260-5320	52 to 64	52, 60, 64	OFDM	BPSK	6.0
	802.11n (20MHz)		52 to 64	52, 60, 64	OFDM	BPSK	MCS0
A, B	802.11a	5500-5700	100 to 140	100, 116, 120, 140	OFDM	BPSK	6.0
	802.11n (20MHz)		100 to 140	100, 116, 120, 140	OFDM	BPSK	MCS0
A, B	802.11a	5745-5825	149 to 165	149, 157, 165	OFDM	BPSK	6.0
	802.11n (20MHz)		149 to 165	149, 157, 165	OFDM	BPSK	MCS0



A D T

RADIATED EMISSION TEST (BELOW 1GHz):

Pre-Scan has been conducted to determine the worst-case mode from all possible combinations between available modulations, data rates and antenna ports (if EUT with antenna diversity architecture).

Following channel(s) was (were) selected for the final test as listed below.

EUT CONFIGURE MODE	MODE	FREQ. BAND (MHz)	AVAILABLE CHANNEL	TESTED CHANNEL	MODULATION TECHNOLOGY	MODULATION TYPE	DATA RATE (Mbps)
A, B	802.11a	5180-5240	36 to 48	36, 44, 48	OFDM	BPSK	6.0
	802.11n (20MHz)		36 to 48	36, 44, 48	OFDM	BPSK	MCS0
A, B	802.11a	5260-5320	52 to 64	52, 60, 64	OFDM	BPSK	6.0
	802.11n (20MHz)		52 to 64	52, 60, 64	OFDM	BPSK	MCS0
A, B	802.11a	5500-5700	100 to 140	100, 116, 120, 140	OFDM	BPSK	6.0
	802.11n (20MHz)		100 to 140	100, 116, 120, 140	OFDM	BPSK	MCS0
A, B	802.11a	5745-5825	149 to 165	149, 157, 165	OFDM	BPSK	6.0
	802.11n (20MHz)		149 to 165	149, 157, 165	OFDM	BPSK	MCS0

POWER LINE CONDUCTED EMISSION TEST:

EUT CONFIGURE MODE	MODE	FREQ. BAND (MHz)	AVAILABLE CHANNEL	TESTED CHANNEL	MODULATION TECHNOLOGY	MODULATION TYPE	DATA RATE (Mbps)
A	802.11a	5260-5320	52 to 64	64	OFDM	BPSK	6.0
B	802.11a	5180-5240	36 to 48	36	OFDM	BPSK	6.0

BANDEDGE MEASUREMENT:

Pre-Scan has been conducted to determine the worst-case mode from all possible combinations between available modulations, data rates and antenna ports (if EUT with antenna diversity architecture).

Following channel(s) was (were) selected for the final test as listed below.

EUT CONFIGURE MODE	MODE	FREQ. BAND (MHz)	AVAILABLE CHANNEL	TESTED CHANNEL	MODULATION TECHNOLOGY	MODULATION TYPE	DATA RATE (Mbps)
A, B	802.11a	5180-5240	36 to 48	36, 44, 48	OFDM	BPSK	6.0
	802.11n (20MHz)		36 to 48	36, 44, 48	OFDM	BPSK	MCS0
A, B	802.11a	5260-5320	52 to 64	52, 60, 64	OFDM	BPSK	6.0
	802.11n (20MHz)		52 to 64	52, 60, 64	OFDM	BPSK	MCS0
A, B	802.11a	5500-5700	100 to 140	100, 116, 140	OFDM	BPSK	6.0
	802.11n (20MHz)		100 to 140	100, 116, 140	OFDM	BPSK	MCS0
A, B	802.11a	5745-5825	149 to 165	149, 157, 165	OFDM	BPSK	6.0
	802.11n (20MHz)		149 to 165	149, 157, 165	OFDM	BPSK	MCS0



ANTENNA PORT CONDUCTED MEASUREMENT:

- This item includes all test value of each mode, but only includes spectrum plot of worst value of each mode.
- Pre-Scan has been conducted to determine the worst-case mode from all possible combinations between available modulations, data rates and antenna ports (if EUT with antenna diversity architecture).
- Following channel(s) was (were) selected for the final test as listed below.

EUT CONFIGURE MODE	MODE	FREQ. BAND (MHz)	AVAILABLE CHANNEL	TESTED CHANNEL	MODULATION TECHNOLOGY	MODULATION TYPE	DATA RATE (Mbps)
A, B	802.11a	5180-5240	36 to 48	36, 44, 48	OFDM	BPSK	6.0
	802.11n (20MHz)		36 to 48	36, 44, 48	OFDM	BPSK	MCS0
A, B	802.11a	5260-5320	52 to 64	52, 60, 64	OFDM	BPSK	6.0
	802.11n (20MHz)		52 to 64	52, 60, 64	OFDM	BPSK	MCS0
A, B	802.11a	5500-5700	100 to 140	100, 116, 140	OFDM	BPSK	6.0
	802.11n (20MHz)		100 to 140	100, 116, 140	OFDM	BPSK	MCS0
A, B	802.11a	5745-5825	149 to 165	149, 157, 165	OFDM	BPSK	6.0
	802.11n (20MHz)		149 to 165	149, 157, 165	OFDM	BPSK	MCS0

TEST CONDITION:

APPLICABLE TO	ENVIRONMENTAL CONDITIONS	INPUT POWER	TESTED BY
RE≥1G	25deg. C, 65%RH	120Vac, 60Hz	Toby Tian
RE<1G	25deg. C, 65%RH	120Vac, 60Hz	Toby Tian
PLC	25deg. C, 65%RH	120Vac, 60Hz	Toby Tian
APCM	25deg. C, 65%RH	120Vac, 60Hz	Howard Kao

3.3 DESCRIPTION OF SUPPORT UNITS

The EUT has been tested as an independent unit together with other necessary accessories or support units.

3.3.1 CONFIGURATION OF SYSTEM UNDER TEST

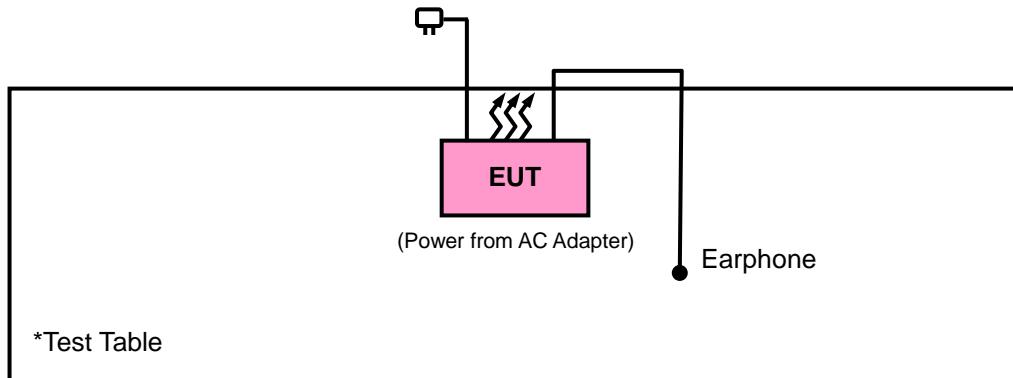

3.4 DUTY CYCLE TEST SIGNAL

Mode A

5180 ~ 5700 MHz

MODULATION TYPE: BPSK

802.11a: Duty cycle of test signal is > 98 %, duty factor is not required.

802.11n (20MHz): Duty cycle of test signal is > 98 %, duty factor is not required.

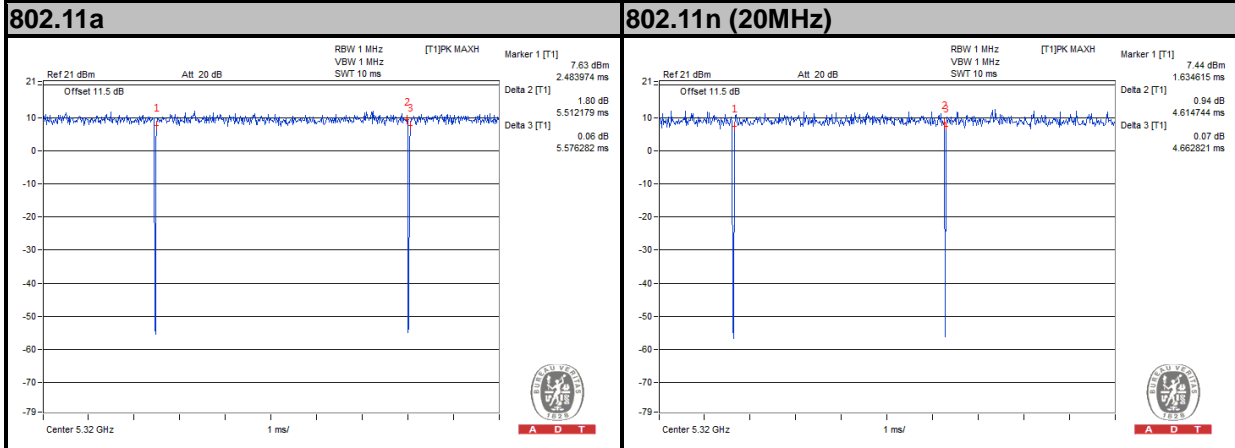

MODULATION TYPE: QPSK

If duty cycle is < 98%, duty factor shall be considered.

802.11a: Duty cycle = $2.772/2.837 = 0.977$, Duty factor = $10 * \log(1/0.977) = 0.10$

802.11n (20MHz): Duty cycle = $2.316/2.372 = 0.976$, Duty factor = $10 * \log(1/0.976) = 0.10$

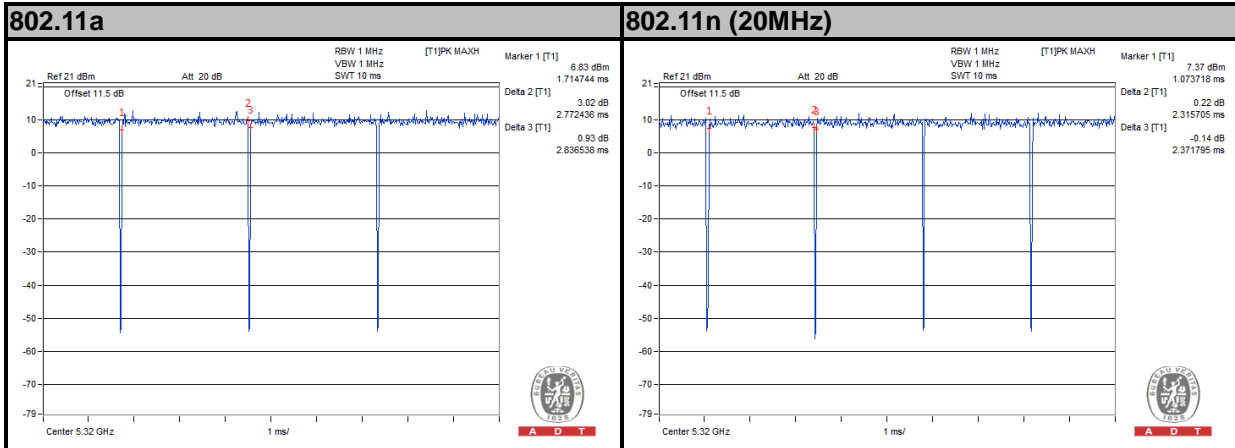



A D T

MODULATION TYPE: 16QAM

If duty cycle is < 98%, duty factor shall be considered.

802.11a: Duty cycle = 1.386/1.442 = 0.961, Duty factor = $10 * \log(1/0.961) = 0.17$

802.11n (20MHz): Duty cycle = 1.170/1.234 = 0.948, Duty factor = $10 * \log(1/0.948) = 0.23$

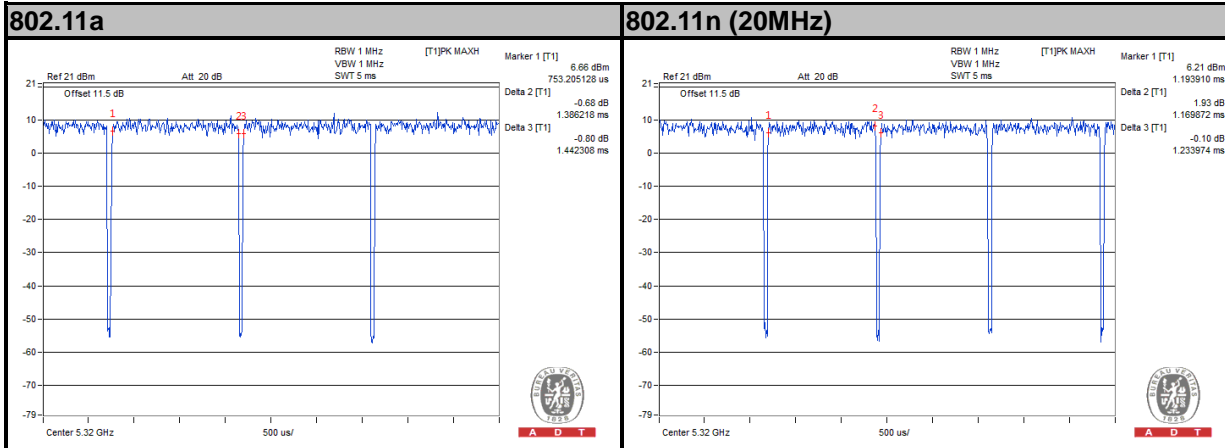

MODULATION TYPE: 64QAM

If duty cycle is < 98%, duty factor shall be considered.

802.11a: Duty cycle = 0.697/0.753 = 0.926, Duty factor = $10 * \log(1/0.926) = 0.34$

802.11n (20MHz): Duty cycle = 0.601/0.665 = 0.604, Duty factor = $10 * \log(1/0.604) = 0.44$

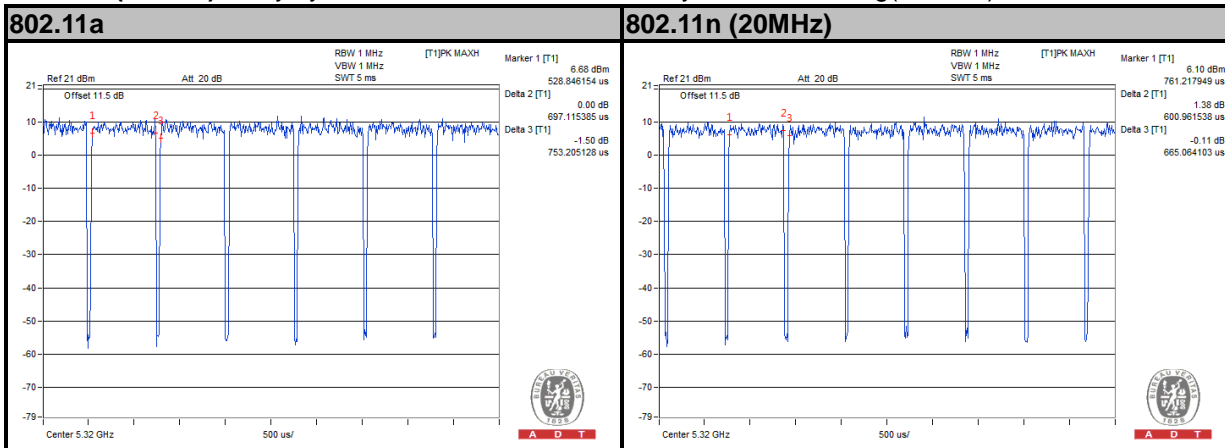



A D T

5725MHz ~ 5825MHz

802.11a: Duty cycle of test signal is > 98 %, duty factor is not required.

802.11n (20MHz): Duty cycle of test signal is > 98 %, duty factor is not required.

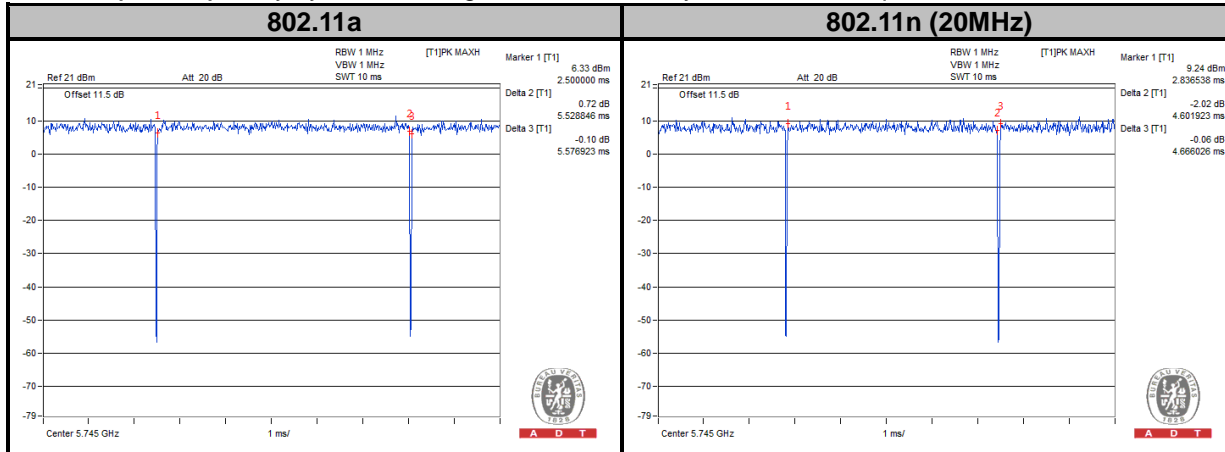



A D T

Mode B

5180 ~ 5700 MHz

MODULATION TYPE: BPSK

802.11a: Duty cycle of test signal is > 98 %, duty factor is not required.

802.11n (20MHz): Duty cycle of test signal is > 98 %, duty factor is not required.

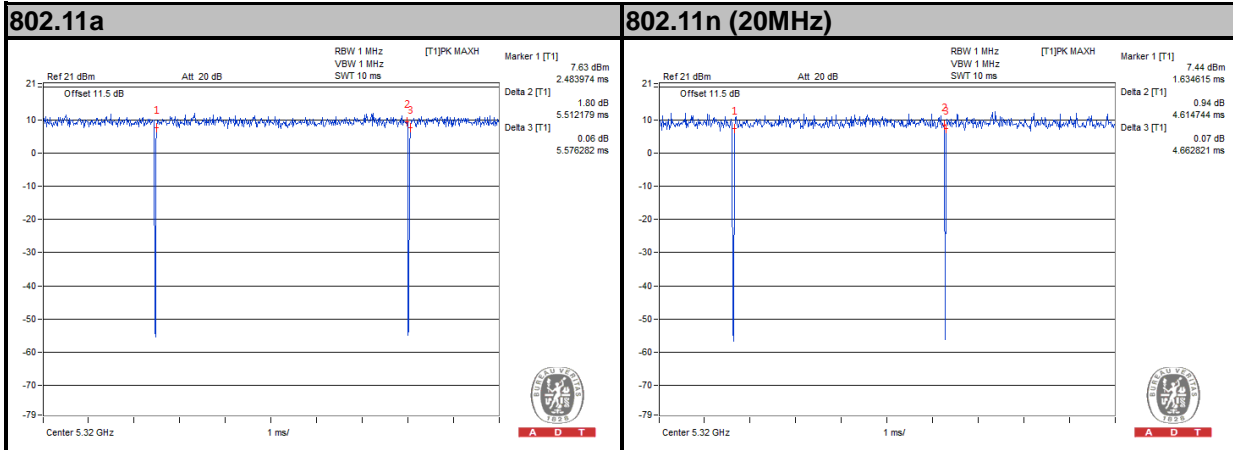

MODULATION TYPE: QPSK

If duty cycle is < 98%, duty factor shall be considered.

802.11a: Duty cycle = $2.772/2.837 = 0.977$, Duty factor = $10 * \log(1/0.977) = 0.10$

802.11n (20MHz): Duty cycle = $2.316/2.372 = 0.976$, Duty factor = $10 * \log(1/0.976) = 0.10$

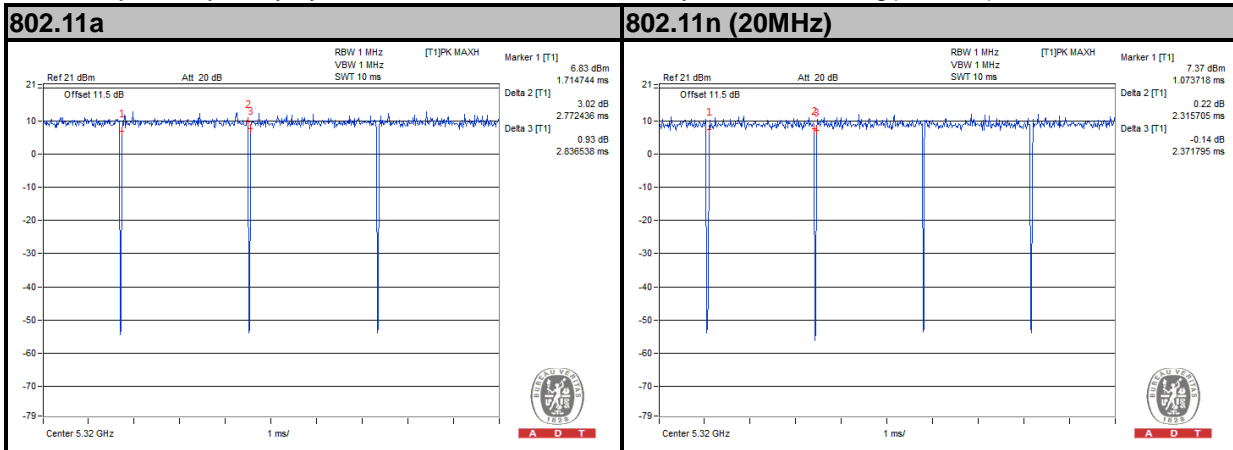



A D T

MODULATION TYPE: 16QAM

If duty cycle is < 98%, duty factor shall be considered.

802.11a: Duty cycle = 1.386/1.442 = 0.961, Duty factor = $10 * \log(1/0.961) = 0.17$

802.11n (20MHz): Duty cycle = 1.170/1.234 = 0.948, Duty factor = $10 * \log(1/0.948) = 0.23$

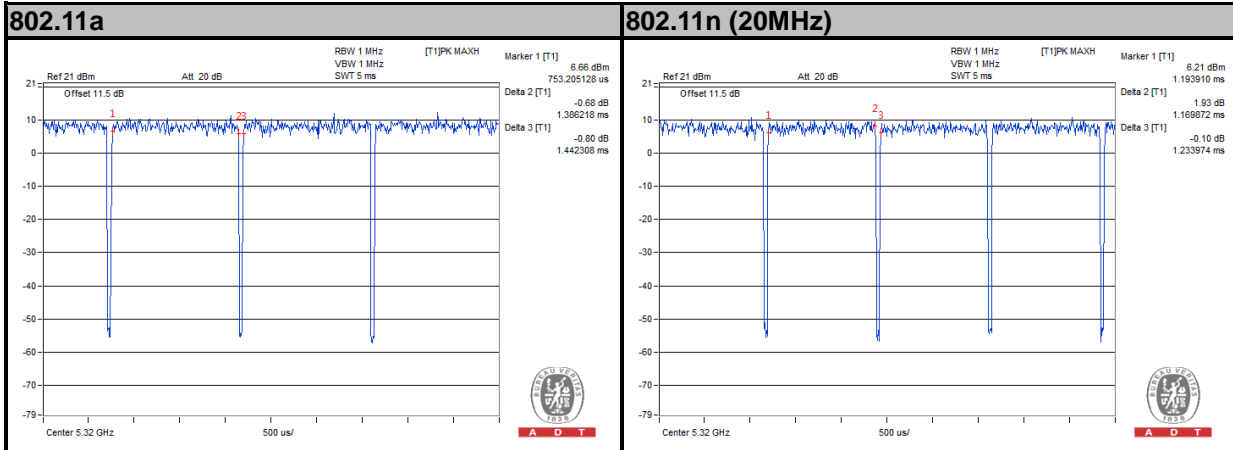

MODULATION TYPE: 64QAM

If duty cycle is < 98%, duty factor shall be considered.

802.11a: Duty cycle = 0.697/0.753 = 0.926, Duty factor = $10 * \log(1/0.926) = 0.34$

802.11n (20MHz): Duty cycle = 0.601/0.665 = 0.604, Duty factor = $10 * \log(1/0.604) = 0.44$

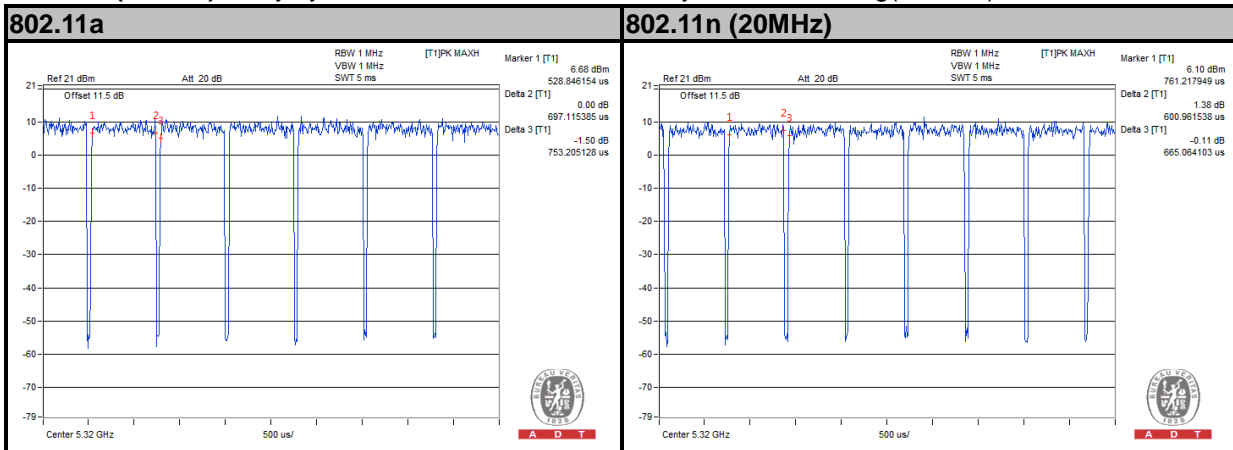



A D T

5725MHz ~ 5825MHz

802.11a: Duty cycle of test signal is > 98 %, duty factor is not required.

802.11n (20MHz): Duty cycle of test signal is > 98 %, duty factor is not required.

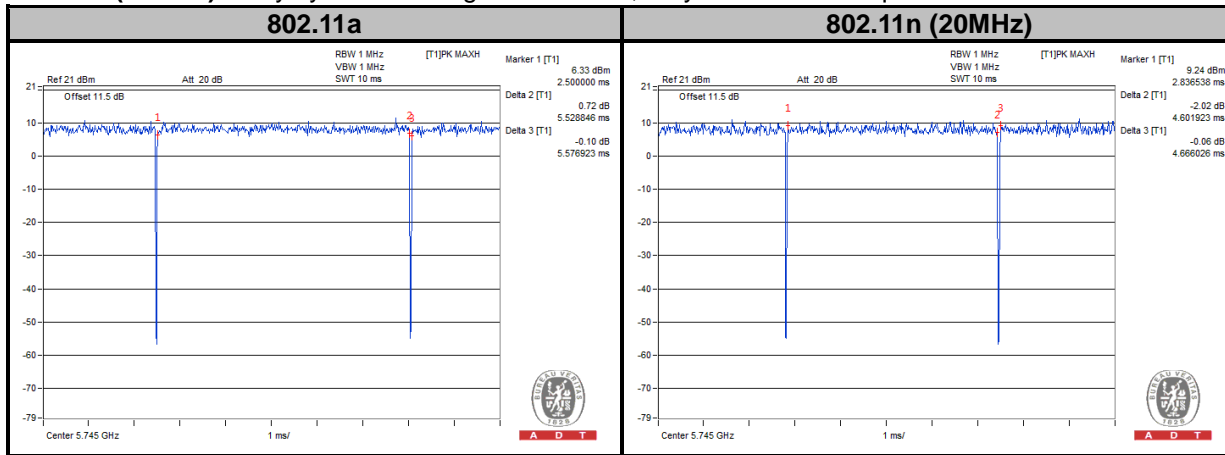



A D T

3.5 GENERAL DESCRIPTION OF APPLIED STANDARDS

The EUT is a RF Product. According to the specifications of the manufacturer, it must comply with the requirements of the following standards:

FCC Part 15, Subpart E (15.407)

789033 D02 General UNII Test Procedures New Rules v01

ANSI C63.10-2013

All test items have been performed and recorded as per the above standards.

NOTE: The EUT has been verified to comply with the requirements of FCC Part 15, Subpart B, Class B (DoC). The test report has been issued separately.

4. TEST TYPES AND RESULTS

4.1 RADIATED EMISSION AND BANDEDGE MEASUREMENT

4.1.1 LIMITS OF RADIATED EMISSION AND BANDEDGE MEASUREMENT

Radiated emissions which fall in the restricted bands must comply with the radiated emission limits specified as below table:

FREQUENCIES (MHz)	FIELD STRENGTH (microvolts/meter)	MEASUREMENT DISTANCE (meters)
0.009 ~ 0.490	2400/F(kHz)	300
0.490 ~ 1.705	24000/F(kHz)	30
1.705 ~ 30.0	30	30
30 ~ 88	100	3
88 ~ 216	150	3
216 ~ 960	200	3
Above 960	500	3

NOTE:

1. The lower limit shall apply at the transition frequencies.
2. Emission level (dBuV/m) = 20 log Emission level (uV/m).
3. For frequencies above 1000MHz, the field strength limits are based on average detector, however, the peak field strength of any emission shall not exceed the maximum permitted average limits, specified above by more than 20dB under any condition of modulation.

4.1.2 LIMITS OF UNWANTED EMISSION OUT OF THE RESTRICTED BANDS

APPLICABLE TO	LIMIT	
789033 D02 General UNII Test Procedures New Rules v01	FIELD STRENGTH AT 3m	
	PK: 74 (dBµV/m)	AV: 54 (dBµV/m)
APPLICABLE TO	EIRP LIMIT	EQUIVALENT FIELD STRENGTH AT 3m
15.407(b)(1)	PK: -27 (dBm/MHz)	PK: 68.2 (dBµV/m)
15.407(b)(2)		
15.407(b)(3)		
15.407(b)(4)	PK: -27 (dBm/MHz) ^{*1} PK: -17 (dBm/MHz) ^{*2}	PK: 68.2 (dBµV/m) ^{*1} PK: 78.2 (dBµV/m) ^{*2}

NOTE: ^{*1} beyond 10MHz of the band edge ^{*2} within 10 MHz of band edge

The following formula is used to convert the equipment isotropic radiated power (eirp) to field strength:

$$E = \frac{1000000\sqrt{30P}}{3} \mu\text{V/m, where P is the eirp (Watts).}$$



A D T

4.1.3 TEST INSTRUMENTS

DESCRIPTION & MANUFACTURER	MODEL NO.	SERIAL NO.	DATE OF CALIBRATION	DUE DATE OF CALIBRATION
Test Receiver Agilent	N9038A	MY51210203	Jan.21, 2015	Jan.21, 2016
Spectrum Analyzer Agilent	N9010A	MY52220314	Sep.03, 2014	Sep.02, 2015
Spectrum Analyzer ROHDE & SCHWARZ	FSU43	101261	Dec. 10, 2014	Dec. 09, 2015
BILOG Antenna SCHWARZBECK	VULB9168	9168-472	Feb. 04, 2015	Feb. 04, 2016
HORN Antenna SCHWARZBECK	BBHA 9120 D	9120D-969	Feb. 09, 2015	Feb. 09, 2016
HORN Antenna SCHWARZBECK	BBHA 9170	9170-480	Feb. 04, 2015	Feb. 04, 2016
Loop Antenna	EM-6879	269	Aug.13, 2014	Aug.12, 2015
Preamplifier Agilent	8449B	3008A01911	Aug. 09, 2014	Aug. 08, 2015
Preamplifier EMCI	EMC 012645	980115	Dec. 12, 2014	Dec. 11, 2015
Preamplifier EMCI	EMC 184045	980116	Jan. 09, 2015	Jan. 08, 2016
Preamplifier EMCI	EMC 330H	980112	Dec. 27, 2013	Dec. 26, 2014
RF signal cable HUBER+SUHNNER	SUCOFLEX 104	309219/4 2950114	Oct. 18, 2014	Oct. 17, 2015
RF signal cable HUBER+SUHNNER	SUCOFLEX 104	250130/4	Oct. 18, 2014	Oct. 17, 2015
RF signal cable Worken	RG-213	NA	Nov. 07, 2014	Nov. 06, 2015
Software BV ADT	E3 6.120103	NA	NA	NA
Antenna Tower MF	MFA-440H	NA	NA	NA
Turn Table MF	MFT-201SS	NA	NA	NA
Antenna Tower & Turn Table Controller MF	MF-7802	NA	NA	NA
Power Meter	ML2495A	1232002	Sep. 17, 2014	Sep. 16, 2015
Power Sensor	MA2411B	1207325	Sep. 17, 2014	Sep. 16, 2015

- NOTE:**
1. The calibration interval of the above test instruments is 12 months and the calibrations are traceable to NML/ROC and NIST/USA.
 2. The calibration interval of the loop antenna is 24 months and the calibrations are traceable to NML/ROC and NIST/USA.
 3. The test was performed in HwaYa Chamber 10.
 4. The horn antenna and HP preamplifier (model: 8449B) are used only for the measurement of emission frequency above 1GHz if tested.
 5. The FCC Site Registration No. is 690701.
 6. The IC Site Registration No. is IC 7450F-10.

4.1.4 TEST PROCEDURES

- a. The EUT was placed on the top of a rotating table 0.8 meters (for below 1GHz) / 1.5 meters (for above 1GHz) above the ground at 3 meter chamber room for test. The table was rotated 360 degrees to determine the position of the highest radiation.
- b. The EUT was set 3 meters away from the interference-receiving antenna, which was mounted on the top of a variable-height antenna tower.
- c. The antenna is a broadband antenna, and its height is varied from one meter to four meters above the ground to determine the maximum value of the field strength. Both horizontal and vertical polarizations of the antenna are set to make the measurement.
- d. For each suspected emission, the EUT was arranged to its worst case and then the antenna was tuned to heights from 1 meter to 4 meters and the rotatable table was turned from 0 degrees to 360 degrees to find the maximum reading.
- e. The test-receiver system was set to Peak Detect Function and Specified Bandwidth with Maximum Hold Mode.
- f. If the emission level of the EUT in peak mode was 10dB lower than the limit specified, then testing could be stopped and the peak values of the EUT would be reported. Otherwise the emissions that did not have 10dB margin would be re-tested one by one using peak, quasi-peak or average method as specified and then reported in a data sheet.

NOTE:

1. The resolution bandwidth and video bandwidth of test receiver/spectrum analyzer is 120kHz for Peak detection (PK) and Quasi-peak detection (QP) at frequency below 1GHz.
2. The resolution bandwidth of test receiver/spectrum analyzer is 1MHz and video bandwidth is 3MHz for Peak detection at frequency above 1GHz.
3. The resolution bandwidth of test receiver/spectrum analyzer is 1MHz and the video bandwidth is 1kHz (Duty cycle < 98%) or 10Hz (Duty cycle > 98%) for Average detection (AV) at frequency above 1GHz.
4. All modes of operation were investigated and the worst-case emissions are reported.

4.1.5 DEVIATION FROM TEST STANDARD

No deviation.

4.1.6 TEST SETUP

<Frequency Range 30MHz ~ 1GHz>

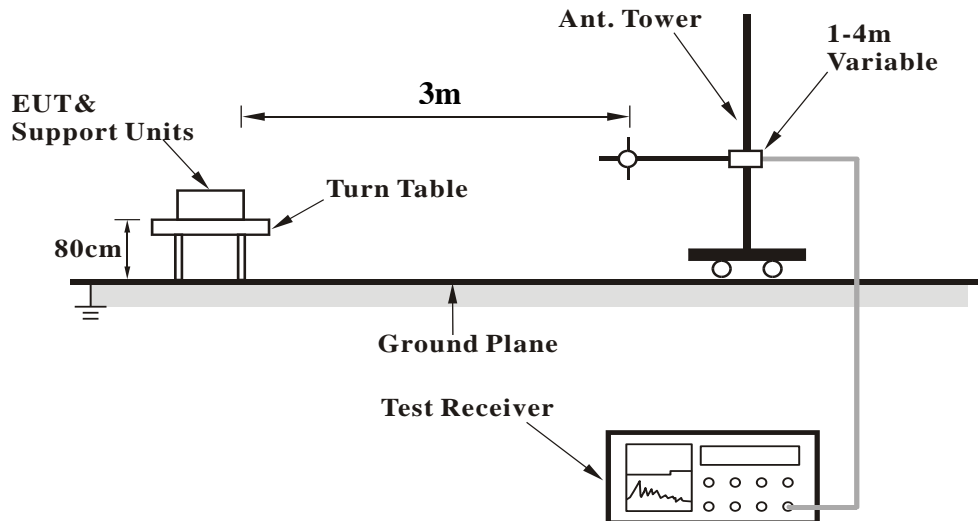

<Frequency Range above 1GHz>

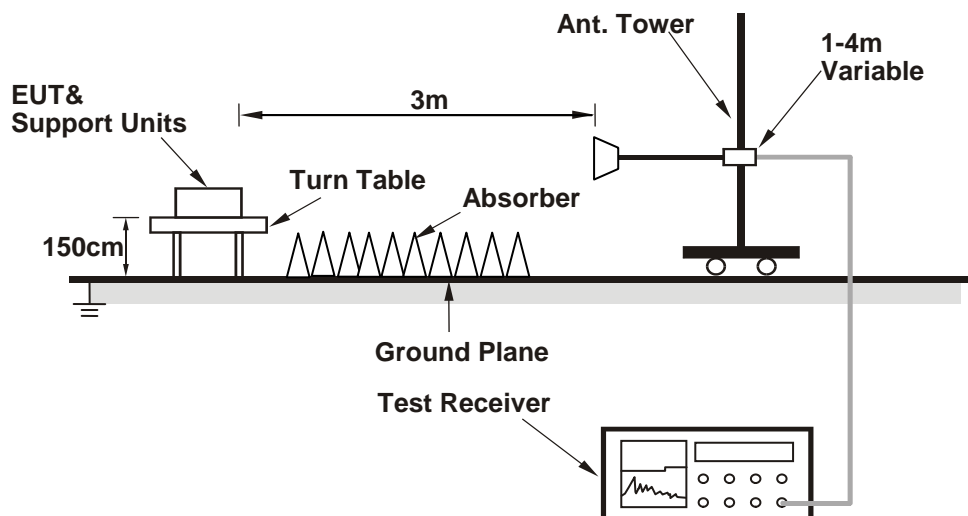

For the actual test configuration, please refer to the attached file (Test Setup Photo).

4.1.7 EUT OPERATING CONDITIONS

- a. Placed the EUT on a testing table.
- b. Use the software to control the EUT under transmission condition continuously at specific channel frequency.



A D T

4.1.8 TEST RESULTS

ABOVE 1GHz WORST-CASE DATA

Mode A

802.11a

EUT TEST CONDITION		MEASUREMENT DETAIL	
CHANNEL	Channel 36	FREQUENCY RANGE	1GHz ~ 40GHz
INPUT POWER	120Vac, 60 Hz	DETECTOR FUNCTION	Peak (PK) Average (AV)
ENVIRONMENTAL CONDITIONS	25deg. C, 65%RH	TESTED BY	Toby Tian

ANTENNA POLARITY & TEST DISTANCE: HORIZONTAL AT 3 M										
FREQ. (MHz)	EMISSION LEVEL (dBuV/m)	READ LEVEL (dBuV)	LIMIT (dBuV/m)	MARGIN (dB)	ANTENNA FACTOR (dB/m)	CABLE LOSS (dB)	PREAMP FACTOR (dB)	ANTENNA HEIGHT (cm)	TABLE ANGLE (Degree)	REMARK
5150	45.07	45.78	54	-8.93	31.32	5.29	37.32	105	297	Average
5150	63.43	64.14	74	-10.57	31.32	5.29	37.32	105	297	Peak
5180	96.22	96.9			31.35	5.31	37.34	105	297	Average
5180	105.61	106.29			31.35	5.31	37.34	105	297	Peak
5402	38.77	39.02	54	-15.23	31.52	5.41	37.18	105	297	Average
5402	59.61	59.86	74	-14.39	31.52	5.41	37.18	105	297	Peak
10360	49.8	54.62	68.2	-18.4	39.19	8.13	52.14	100	300	Peak
ANTENNA POLARITY & TEST DISTANCE: VERTICAL AT 3 M										
FREQ. (MHz)	EMISSION LEVEL (dBuV/m)	READ LEVEL (dBuV)	LIMIT (dBuV/m)	MARGIN (dB)	ANTENNA FACTOR (dB/m)	CABLE LOSS (dB)	PREAMP FACTOR (dB)	ANTENNA HEIGHT (cm)	TABLE ANGLE (Degree)	REMARK
5150	52.68	53.39	54	-1.32	31.32	5.29	37.32	101	188	Average
5150	69.49	70.2	74	-4.51	31.32	5.29	37.32	101	188	Peak
5180	103	103.68			31.35	5.31	37.34	101	188	Average
5180	111.51	112.19			31.35	5.31	37.34	101	188	Peak
5400	39.45	39.7	54	-14.55	31.52	5.41	37.18	101	188	Average
5400	60.06	60.31	74	-13.94	31.52	5.41	37.18	101	188	Peak
10360	49.9	54.72	68.2	-18.3	39.19	8.13	52.14	100	83	Peak

REMARKS:

- Emission Level = Read Level + Antenna Factor + Cable Loss - Preamp Factor
Margin value = Emission level – Limit value
- 5180MHz: Fundamental frequency.
- 10360MHz: Out of restricted band



A D T

EUT TEST CONDITION		MEASUREMENT DETAIL	
CHANNEL	Channel 44	FREQUENCY RANGE	1GHz ~ 40GHz
INPUT POWER	120Vac, 60 Hz	DETECTOR FUNCTION	Peak (PK) Average (AV)
ENVIRONMENTAL CONDITIONS	25deg. C, 65%RH	TESTED BY	Toby Tian

ANTENNA POLARITY & TEST DISTANCE: HORIZONTAL AT 3 M										
FREQ. (MHz)	EMISSION LEVEL (dBuV/m)	READ LEVEL (dBuV)	LIMIT (dBuV/m)	MARGIN (dB)	ANTENNA FACTOR (dB/m)	CABLE LOSS (dB)	PREAMP FACTOR (dB)	ANTENNA HEIGHT (cm)	TABLE ANGLE (Degree)	REMARK
5150	39.14	39.85	54	-14.86	31.32	5.29	37.32	102	296	Average
5150	59.82	60.53	74	-14.18	31.32	5.29	37.32	102	296	Peak
5220	98.81	99.47			31.37	5.33	37.36	102	296	Average
5220	107.83	108.49			31.37	5.33	37.36	102	296	Peak
5402	38.79	39.04	54	-15.21	31.52	5.41	37.18	102	296	Average
5402	60.81	61.06	74	-13.19	31.52	5.41	37.18	102	296	Peak
10440	49.6	54.6	68.2	-18.6	39.29	8.19	52.48	100	297	Peak
ANTENNA POLARITY & TEST DISTANCE: VERTICAL AT 3 M										
FREQ. (MHz)	EMISSION LEVEL (dBuV/m)	READ LEVEL (dBuV)	LIMIT (dBuV/m)	MARGIN (dB)	ANTENNA FACTOR (dB/m)	CABLE LOSS (dB)	PREAMP FACTOR (dB)	ANTENNA HEIGHT (cm)	TABLE ANGLE (Degree)	REMARK
5094	43.3	44.03	54	-1.32	31.28	5.27	37.28	100	185	Average
5094	60.85	61.58	74	-4.51	31.28	5.27	37.28	100	185	Peak
5220	105.08	105.74			31.37	5.33	37.36	100	185	Average
5220	113.57	114.23			31.37	5.33	37.36	100	185	Peak
5380	40.75	41.02	54	-14.55	31.51	5.4	37.18	100	185	Average
5380	60.68	60.95	74	-13.94	31.51	5.4	37.18	100	185	Peak
10440	49.68	54.68	68.2	-18.52	39.29	8.19	52.48	100	136	Peak

REMARKS:

- Emission Level = Read Level + Antenna Factor + Cable Loss - Preamp Factor
Margin value = Emission level – Limit value
- 5220MHz: Fundamental frequency.
- 10440MHz: Out of restricted band



A D T

EUT TEST CONDITION		MEASUREMENT DETAIL	
CHANNEL	Channel 48	FREQUENCY RANGE	1GHz ~ 40GHz
INPUT POWER	120Vac, 60 Hz	DETECTOR FUNCTION	Peak (PK) Average (AV)
ENVIRONMENTAL CONDITIONS	25deg. C, 65%RH	TESTED BY	Toby Tian

ANTENNA POLARITY & TEST DISTANCE: HORIZONTAL AT 3 M										
FREQ. (MHz)	EMISSION LEVEL (dBuV/m)	READ LEVEL (dBuV)	LIMIT (dBuV/m)	MARGIN (dB)	ANTENNA FACTOR (dB/m)	CABLE LOSS (dB)	PREAMP FACTOR (dB)	ANTENNA HEIGHT (cm)	TABLE ANGLE (Degree)	REMARK
5078	38.72	39.46	54	-15.28	31.27	5.26	37.27	102	295	Average
5078	59.6	60.34	74	-14.4	31.27	5.26	37.27	102	295	Peak
5240	98.75	99.34			31.39	5.34	37.32	102	295	Average
5240	107.73	108.32			31.39	5.34	37.32	102	295	Peak
5374	38.8	39.09	54	-15.2	31.49	5.4	37.18	102	295	Average
5374	59.99	60.28	74	-14.01	31.49	5.4	37.18	102	295	Peak
10480	50.85	55.99	68.2	-17.35	39.37	8.2	52.71	100	301	Peak
ANTENNA POLARITY & TEST DISTANCE: VERTICAL AT 3 M										
FREQ. (MHz)	EMISSION LEVEL (dBuV/m)	READ LEVEL (dBuV)	LIMIT (dBuV/m)	MARGIN (dB)	ANTENNA FACTOR (dB/m)	CABLE LOSS (dB)	PREAMP FACTOR (dB)	ANTENNA HEIGHT (cm)	TABLE ANGLE (Degree)	REMARK
5056	41.9	42.65	54	-1.32	31.25	5.25	37.25	100	176	Average
5056	60.37	61.12	74	-4.51	31.25	5.25	37.25	100	176	Peak
5240	105.12	105.71			31.39	5.34	37.32	100	176	Average
5240	113.51	114.1			31.39	5.34	37.32	100	176	Peak
5422	40.84	41.07	54	-14.55	31.53	5.42	37.18	100	176	Average
5422	61.3	61.53	74	-13.94	31.53	5.42	37.18	100	176	Peak
10480	50.92	56.06	68.2	-17.28	39.37	8.2	52.71	100	34	Peak

REMARKS:

- Emission Level = Read Level + Antenna Factor + Cable Loss - Preamp Factor
Margin value = Emission level – Limit value
- 5240MHz: Fundamental frequency.
- 10480MHz: Out of restricted band



A D T

EUT TEST CONDITION		MEASUREMENT DETAIL	
CHANNEL	Channel 52	FREQUENCY RANGE	1GHz ~ 40GHz
INPUT POWER	120Vac, 60 Hz	DETECTOR FUNCTION	Peak (PK) Average (AV)
ENVIRONMENTAL CONDITIONS	25deg. C, 65%RH	TESTED BY	Toby Tian

ANTENNA POLARITY & TEST DISTANCE: HORIZONTAL AT 3 M										
FREQ. (MHz)	EMISSION LEVEL (dBuV/m)	READ LEVEL (dBuV)	LIMIT (dBuV/m)	MARGIN (dB)	ANTENNA FACTOR (dB/m)	CABLE LOSS (dB)	PREAMP FACTOR (dB)	ANTENNA HEIGHT (cm)	TABLE ANGLE (Degree)	REMARK
5082	38.32	39.06	54	-15.68	31.27	5.26	37.27	106	196	Average
5082	59.43	60.17	74	-14.57	31.27	5.26	37.27	106	196	Peak
5260	99.55	100.07			31.41	5.34	37.27	106	196	Average
5260	108.24	108.76			31.41	5.34	37.27	106	196	Peak
5374	39.25	39.54	54	-14.75	31.49	5.4	37.18	106	196	Average
5374	59.72	60.01	74	-14.28	31.49	5.4	37.18	106	196	Peak
10520	50.49	55.66	68.2	-17.71	39.43	8.23	52.83	100	185	Peak
ANTENNA POLARITY & TEST DISTANCE: VERTICAL AT 3 M										
FREQ. (MHz)	EMISSION LEVEL (dBuV/m)	READ LEVEL (dBuV)	LIMIT (dBuV/m)	MARGIN (dB)	ANTENNA FACTOR (dB/m)	CABLE LOSS (dB)	PREAMP FACTOR (dB)	ANTENNA HEIGHT (cm)	TABLE ANGLE (Degree)	REMARK
5082	41.71	42.45	54	-12.29	31.27	5.26	37.27	100	186	Average
5082	59.66	60.4	74	-14.34	31.27	5.26	37.27	100	186	Peak
5260	104.91	105.43			31.41	5.34	37.27	100	186	Average
5260	112.56	113.08			31.41	5.34	37.27	100	186	Peak
5440	41.76	41.9	54	-12.24	31.55	5.44	37.13	100	186	Average
5440	59.93	60.07	74	-14.07	31.55	5.44	37.13	100	186	Peak
10520	53.13	58.3	68.2	-15.07	39.43	8.23	52.83	100	319	Peak

REMARKS:

- Emission Level = Read Level + Antenna Factor + Cable Loss - Preamp Factor
Margin value = Emission level – Limit value
- 5260MHz: Fundamental frequency.
- 10520MHz: Out of restricted band



A D T

EUT TEST CONDITION		MEASUREMENT DETAIL	
CHANNEL	Channel 60	FREQUENCY RANGE	1GHz ~ 40GHz
INPUT POWER	120Vac, 60 Hz	DETECTOR FUNCTION	Peak (PK) Average (AV)
ENVIRONMENTAL CONDITIONS	25deg. C, 65%RH	TESTED BY	Toby Tian

ANTENNA POLARITY & TEST DISTANCE: HORIZONTAL AT 3 M										
FREQ. (MHz)	EMISSION LEVEL (dBuV/m)	READ LEVEL (dBuV)	LIMIT (dBuV/m)	MARGIN (dB)	ANTENNA FACTOR (dB/m)	CABLE LOSS (dB)	PREAMP FACTOR (dB)	ANTENNA HEIGHT (cm)	TABLE ANGLE (Degree)	REMARK
5032	37.89	38.66	54	-16.11	31.23	5.24	37.24	105	190	Average
5032	59.2	59.97	74	-14.8	31.23	5.24	37.24	105	190	Peak
5300	99.32	99.7			31.44	5.37	37.19	105	190	Average
5300	108.66	109.04			31.44	5.37	37.19	105	190	Peak
5350	45.54	45.85	54	-8.46	31.48	5.39	37.18	105	190	Average
5350	62.43	62.74	74	-11.57	31.48	5.39	37.18	105	190	Peak
10600	41.2	45.76	54	-12.8	39.57	8.28	52.41	100	166	Average
10600	52.2	56.76	74	-21.8	39.57	8.28	52.41	100	166	Peak
ANTENNA POLARITY & TEST DISTANCE: VERTICAL AT 3 M										
FREQ. (MHz)	EMISSION LEVEL (dBuV/m)	READ LEVEL (dBuV)	LIMIT (dBuV/m)	MARGIN (dB)	ANTENNA FACTOR (dB/m)	CABLE LOSS (dB)	PREAMP FACTOR (dB)	ANTENNA HEIGHT (cm)	TABLE ANGLE (Degree)	REMARK
5150	41.71	42.42	54	-12.29	31.32	5.29	37.32	100	188	Average
5150	60.16	60.87	74	-13.84	31.32	5.29	37.32	100	188	Peak
5300	104.52	104.9			31.44	5.37	37.19	100	188	Average
5300	112.2	112.58			31.44	5.37	37.19	100	188	Peak
5350	48.87	49.18	54	-5.13	31.48	5.39	37.18	100	188	Average
5350	65.51	65.82	74	-8.49	31.48	5.39	37.18	100	188	Peak
10600	41.91	46.47	54	-12.09	39.57	8.28	52.41	100	263	Average
10600	52.65	57.21	74	-21.35	39.57	8.28	52.41	100	263	Peak

REMARKS:

- Emission Level = Read Level + Antenna Factor + Cable Loss - Preamp Factor
Margin value = Emission level – Limit value
- 5300MHz: Fundamental frequency.



A D T

EUT TEST CONDITION		MEASUREMENT DETAIL	
CHANNEL	Channel 64	FREQUENCY RANGE	1GHz ~ 40GHz
INPUT POWER	120Vac, 60 Hz	DETECTOR FUNCTION	Peak (PK) Average (AV)
ENVIRONMENTAL CONDITIONS	25deg. C, 65%RH	TESTED BY	Toby Tian

ANTENNA POLARITY & TEST DISTANCE: HORIZONTAL AT 3 M										
FREQ. (MHz)	EMISSION LEVEL (dBuV/m)	READ LEVEL (dBuV)	LIMIT (dBuV/m)	MARGIN (dB)	ANTENNA FACTOR (dB/m)	CABLE LOSS (dB)	PREAMP FACTOR (dB)	ANTENNA HEIGHT (cm)	TABLE ANGLE (Degree)	REMARK
5132	37.65	38.36	54	-16.35	31.31	5.28	37.3	104	192	Average
5132	59.52	60.23	74	-14.48	31.31	5.28	37.3	104	192	Peak
5320	98.02	98.38			31.45	5.38	37.19	104	192	Average
5320	107.53	107.89			31.45	5.38	37.19	104	192	Peak
5350	48.33	48.64	54	-5.67	31.48	5.39	37.18	104	192	Average
5350	64.93	65.24	74	-9.07	31.48	5.39	37.18	104	192	Peak
10640	41.6	45.93	54	-12.4	39.62	8.32	52.27	100	114	Average
10640	53.87	58.2	74	-20.13	39.62	8.32	52.27	100	114	Peak
ANTENNA POLARITY & TEST DISTANCE: VERTICAL AT 3 M										
FREQ. (MHz)	EMISSION LEVEL (dBuV/m)	READ LEVEL (dBuV)	LIMIT (dBuV/m)	MARGIN (dB)	ANTENNA FACTOR (dB/m)	CABLE LOSS (dB)	PREAMP FACTOR (dB)	ANTENNA HEIGHT (cm)	TABLE ANGLE (Degree)	REMARK
5010	39.69	40.49	54	-14.31	31.21	5.22	37.23	100	183	Average
5010	58.92	59.72	74	-15.08	31.21	5.22	37.23	100	183	Peak
5320	103.27	103.63			31.45	5.38	37.19	100	183	Average
5320	111.12	111.48			31.45	5.38	37.19	100	183	Peak
5350	52.93	53.24	54	-1.07	31.48	5.39	37.18	100	183	Average
5350	70.14	70.45	74	-3.86	31.48	5.39	37.18	100	183	Peak
10640	41.94	46.27	54	-12.06	39.62	8.32	52.27	100	318	Average
10640	53.33	57.66	74	-20.67	39.62	8.32	52.27	100	318	Peak

REMARKS:

- Emission Level = Read Level + Antenna Factor + Cable Loss - Preamp Factor
Margin value = Emission level – Limit value
- 5320MHz: Fundamental frequency.



A D T

EUT TEST CONDITION		MEASUREMENT DETAIL	
CHANNEL	Channel 100	FREQUENCY RANGE	1GHz ~ 40GHz
INPUT POWER	120Vac, 60 Hz	DETECTOR FUNCTION	Peak (PK) Average (AV)
ENVIRONMENTAL CONDITIONS	25deg. C, 65%RH	TESTED BY	Toby Tian

ANTENNA POLARITY & TEST DISTANCE: HORIZONTAL AT 3 M										
FREQ. (MHz)	EMISSION LEVEL (dBuV/m)	READ LEVEL (dBuV)	LIMIT (dBuV/m)	MARGIN (dB)	ANTENNA FACTOR (dB/m)	CABLE LOSS (dB)	PREAMP FACTOR (dB)	ANTENNA HEIGHT (cm)	TABLE ANGLE (Degree)	REMARK
5368	45.94	46.23	54	-8.06	31.49	5.4	37.18	118	235	Average
5368	60.51	60.8	74	-13.49	31.49	5.4	37.18	118	235	Peak
5470	66.97	67.03	68.2	-1.23	31.57	5.45	37.08	118	235	Peak
5500	99.12	99.09			31.6	5.46	37.03	118	235	Average
5500	108.19	108.16			31.6	5.46	37.03	118	235	Peak
5725	59.17	59.05	68.2	-9.03	31.96	5.59	37.43	118	235	Peak
11000	41.49	46.18	54	-12.51	40.2	8.56	53.45	100	272	Average
11000	51.43	56.12	74	-22.57	40.2	8.56	53.45	100	272	Peak
ANTENNA POLARITY & TEST DISTANCE: VERTICAL AT 3 M										
FREQ. (MHz)	EMISSION LEVEL (dBuV/m)	READ LEVEL (dBuV)	LIMIT (dBuV/m)	MARGIN (dB)	ANTENNA FACTOR (dB/m)	CABLE LOSS (dB)	PREAMP FACTOR (dB)	ANTENNA HEIGHT (cm)	TABLE ANGLE (Degree)	REMARK
5452	41.58	41.66	54	-12.42	31.56	5.44	37.08	101	202	Average
5452	59.9	59.98	74	-14.1	31.56	5.44	37.08	101	202	Peak
5470	62.46	62.52	68.2	-5.74	31.57	5.45	37.08	101	202	Peak
5500	95.44	95.41			31.6	5.46	37.03	101	202	Average
5500	104.4	104.37			31.6	5.46	37.03	101	202	Peak
5725	59.37	59.25	68.2	-8.83	31.96	5.59	37.43	101	202	Peak
11000	41.1	45.79	54	-12.9	40.2	8.56	53.45	100	112	Average
11000	51.5	56.19	74	-22.5	40.2	8.56	53.45	100	112	Peak

REMARKS:

- Emission Level = Read Level + Antenna Factor + Cable Loss - Preamp Factor
Margin value = Emission level – Limit value
- 5500MHz: Fundamental frequency.
- 5470MHz & 5725MHz: Out of restricted band



A D T

EUT TEST CONDITION		MEASUREMENT DETAIL	
CHANNEL	Channel 116	FREQUENCY RANGE	1GHz ~ 40GHz
INPUT POWER	120Vac, 60 Hz	DETECTOR FUNCTION	Peak (PK) Average (AV)
ENVIRONMENTAL CONDITIONS	25deg. C, 65%RH	TESTED BY	Toby Tian

ANTENNA POLARITY & TEST DISTANCE: HORIZONTAL AT 3 M										
FREQ. (MHz)	EMISSION LEVEL (dBuV/m)	READ LEVEL (dBuV)	LIMIT (dBuV/m)	MARGIN (dB)	ANTENNA FACTOR (dB/m)	CABLE LOSS (dB)	PREAMP FACTOR (dB)	ANTENNA HEIGHT (cm)	TABLE ANGLE (Degree)	REMARK
5444	40.46	40.6	54	-13.54	31.55	5.44	37.13	118	244	Average
5444	59.34	59.48	74	-14.66	31.55	5.44	37.13	118	244	Peak
5470	58.15	58.21	68.2	-10.05	31.57	5.45	37.08	118	244	Peak
5580	102.17	102.12			31.71	5.5	37.16	118	244	Average
5580	110.81	110.76			31.71	5.5	37.16	118	244	Peak
5725	59.55	59.43	68.2	-8.65	31.96	5.59	37.43	118	244	Peak
11160	42.31	46.89	54	-11.69	40.1	8.71	53.39	100	245	Average
11160	53.77	58.35	74	-20.23	40.1	8.71	53.39	100	245	Peak
ANTENNA POLARITY & TEST DISTANCE: VERTICAL AT 3 M										
FREQ. (MHz)	EMISSION LEVEL (dBuV/m)	READ LEVEL (dBuV)	LIMIT (dBuV/m)	MARGIN (dB)	ANTENNA FACTOR (dB/m)	CABLE LOSS (dB)	PREAMP FACTOR (dB)	ANTENNA HEIGHT (cm)	TABLE ANGLE (Degree)	REMARK
5454	39.02	39.1	54	-14.98	31.56	5.44	37.08	113	206	Average
5454	60.78	60.86	74	-13.22	31.56	5.44	37.08	113	206	Peak
5470	58.2	58.26	68.2	-10	31.57	5.45	37.08	113	206	Peak
5580	97.05	97			31.71	5.5	37.16	113	206	Average
5580	106.48	106.43			31.71	5.5	37.16	113	206	Peak
5725	59.21	59.09	68.2	-8.99	31.96	5.59	37.43	113	206	Peak
11160	42.07	46.65	54	-11.93	40.1	8.71	53.39	100	110	Average
11160	51.96	56.54	74	-22.04	40.1	8.71	53.39	100	110	Peak

REMARKS:

- Emission Level = Read Level + Antenna Factor + Cable Loss - Preamp Factor
Margin value = Emission level – Limit value
- 5580MHz: Fundamental frequency.
- 5470MHz & 5725MHz: Out of restricted band



A D T

EUT TEST CONDITION		MEASUREMENT DETAIL	
CHANNEL	Channel 120	FREQUENCY RANGE	1GHz ~ 40GHz
INPUT POWER	120Vac, 60 Hz	DETECTOR FUNCTION	Peak (PK) Average (AV)
ENVIRONMENTAL CONDITIONS	25deg. C, 65%RH	TESTED BY	Toby Tian

ANTENNA POLARITY & TEST DISTANCE: HORIZONTAL AT 3 M										
FREQ. (MHz)	EMISSION LEVEL (dBuV/m)	READ LEVEL (dBuV)	LIMIT (dBuV/m)	MARGIN (dB)	ANTENNA FACTOR (dB/m)	CABLE LOSS (dB)	PREAMP FACTOR (dB)	ANTENNA HEIGHT (cm)	TABLE ANGLE (Degree)	REMARK
5442	40.19	40.33	54	-13.81	31.55	5.44	37.13	123	245	Average
5442	60.33	60.47	74	-13.67	31.55	5.44	37.13	123	245	Peak
5470	58.04	58.1	68.2	-10.16	31.57	5.45	37.08	123	245	Peak
5600	105.63	105.5			31.77	5.52	37.16	123	245	Average
5600	114.53	114.4			31.77	5.52	37.16	123	245	Peak
5725	60.81	60.69	68.2	-7.39	31.96	5.59	37.43	123	245	Peak
11200	41.82	46.14	54	-12.18	40.08	8.76	53.16	100	244	Average
11200	52.4	56.72	74	-21.6	40.08	8.76	53.16	100	244	Peak
ANTENNA POLARITY & TEST DISTANCE: VERTICAL AT 3 M										
FREQ. (MHz)	EMISSION LEVEL (dBuV/m)	READ LEVEL (dBuV)	LIMIT (dBuV/m)	MARGIN (dB)	ANTENNA FACTOR (dB/m)	CABLE LOSS (dB)	PREAMP FACTOR (dB)	ANTENNA HEIGHT (cm)	TABLE ANGLE (Degree)	REMARK
5384	38.72	38.99	54	-15.28	31.51	5.4	37.18	102	276	Average
5384	59.88	60.15	74	-14.12	31.51	5.4	37.18	102	276	Peak
5470	57.8	57.86	68.2	-10.4	31.57	5.45	37.08	102	276	Peak
5600	101.67	101.54			31.77	5.52	37.16	102	276	Average
5600	111.4	111.27			31.77	5.52	37.16	102	276	Peak
5725	59.99	59.87	68.2	-8.21	31.96	5.59	37.43	102	276	Peak
11200	41.61	45.93	54	-12.39	40.08	8.76	53.16	100	111	Average
11200	52.04	56.36	74	-21.96	40.08	8.76	53.16	100	111	Peak

REMARKS:

- Emission Level = Read Level + Antenna Factor + Cable Loss - Preamp Factor
Margin value = Emission level – Limit value
- 5600MHz: Fundamental frequency.
- 5470MHz & 5725MHz: Out of restricted band



A D T

EUT TEST CONDITION		MEASUREMENT DETAIL	
CHANNEL	Channel 140	FREQUENCY RANGE	1GHz ~ 40GHz
INPUT POWER	120Vac, 60 Hz	DETECTOR FUNCTION	Peak (PK) Average (AV)
ENVIRONMENTAL CONDITIONS	25deg. C, 65%RH	TESTED BY	Toby Tian

ANTENNA POLARITY & TEST DISTANCE: HORIZONTAL AT 3 M										
FREQ. (MHz)	EMISSION LEVEL (dBuV/m)	READ LEVEL (dBuV)	LIMIT (dBuV/m)	MARGIN (dB)	ANTENNA FACTOR (dB/m)	CABLE LOSS (dB)	PREAMP FACTOR (dB)	ANTENNA HEIGHT (cm)	TABLE ANGLE (Degree)	REMARK
5446	38.74	38.87	54	-15.26	31.56	5.44	37.13	119	248	Average
5446	59.64	59.77	74	-14.36	31.56	5.44	37.13	119	248	Peak
5470	57.8	57.86	68.2	-10.4	31.57	5.45	37.08	119	248	Peak
5700	99.51	99.44			31.9	5.57	37.4	119	248	Average
5700	108.93	108.86			31.9	5.57	37.4	119	248	Peak
5725	66.97	66.85	68.2	-1.23	31.96	5.59	37.43	119	248	Peak
11400	42.05	45.27	54	-11.95	39.96	8.95	52.13	100	206	Average
11400	52.59	55.81	74	-21.41	39.96	8.95	52.13	100	206	Peak
ANTENNA POLARITY & TEST DISTANCE: VERTICAL AT 3 M										
FREQ. (MHz)	EMISSION LEVEL (dBuV/m)	READ LEVEL (dBuV)	LIMIT (dBuV/m)	MARGIN (dB)	ANTENNA FACTOR (dB/m)	CABLE LOSS (dB)	PREAMP FACTOR (dB)	ANTENNA HEIGHT (cm)	TABLE ANGLE (Degree)	REMARK
5352	37.81	38.12	54	-16.19	31.48	5.39	37.18	123	264	Average
5352	59.18	59.49	74	-14.82	31.48	5.39	37.18	123	264	Peak
5470	58.05	58.11	68.2	-10.15	31.57	5.45	37.08	123	264	Peak
5700	96.96	96.89			31.9	5.57	37.4	123	264	Average
5700	106.35	106.28			31.9	5.57	37.4	123	264	Peak
5725	64.75	64.63	68.2	-3.45	31.96	5.59	37.43	123	264	Peak
11400	43.14	46.36	54	-10.86	39.96	8.95	52.13	100	122	Average
11400	53.41	56.63	74	-20.59	39.96	8.95	52.13	100	122	Peak

REMARKS:

- Emission Level = Read Level + Antenna Factor + Cable Loss - Preamp Factor
Margin value = Emission level – Limit value
- 5700MHz: Fundamental frequency.
- 5470MHz & 5725MHz: Out of restricted band



A D T

EUT TEST CONDITION		MEASUREMENT DETAIL	
CHANNEL	Channel 149	FREQUENCY RANGE	1GHz ~ 40GHz
INPUT POWER	120Vac, 60 Hz	DETECTOR FUNCTION	Peak (PK) Average (AV)
ENVIRONMENTAL CONDITIONS	25deg. C, 65%RH	TESTED BY	Toby Tian

ANTENNA POLARITY & TEST DISTANCE: HORIZONTAL AT 3 M

FREQ. (MHz)	EMISSION LEVEL (dBuV/m)	READ LEVEL (dBuV)	LIMIT (dBuV/m)	MARGIN (dB)	ANTENNA FACTOR (dB/m)	CABLE LOSS (dB)	PREAMP FACTOR (dB)	ANTENNA HEIGHT (cm)	TABLE ANGLE (Degree)	REMARK
5714	61.62	61.53	68.2	-6.58	31.93	5.59	37.43	100	242	Peak
5725	67.43	67.31	78.2	-10.77	31.96	5.59	37.43	100	242	Peak
5745	95.8	95.68			31.99	5.6	37.47	100	242	Average
5745	105.18	105.06			31.99	5.6	37.47	100	242	Peak
5850	60.53	60.23	78.2	-17.67	32.15	5.66	37.51	100	242	Peak
5861	59.58	59.24	68.2	-8.62	32.18	5.66	37.5	100	242	Peak
11490	40.97	44.84	54	-13.03	39.91	9.05	52.83	100	38	Average
11490	51.67	55.54	74	-22.33	39.91	9.05	52.83	100	38	Peak

ANTENNA POLARITY & TEST DISTANCE: VERTICAL AT 3 M

FREQ. (MHz)	EMISSION LEVEL (dBuV/m)	READ LEVEL (dBuV)	LIMIT (dBuV/m)	MARGIN (dB)	ANTENNA FACTOR (dB/m)	CABLE LOSS (dB)	PREAMP FACTOR (dB)	ANTENNA HEIGHT (cm)	TABLE ANGLE (Degree)	REMARK
5714	61.97	61.88	68.2	-6.23	31.93	5.59	37.43	118	126	Peak
5725	71.71	71.59	78.2	-6.49	31.96	5.59	37.43	118	126	Peak
5745	99.94	99.82			31.99	5.6	37.47	118	126	Average
5745	109.48	109.36			31.99	5.6	37.47	118	126	Peak
5850	60.22	59.92	78.2	-17.98	32.15	5.66	37.51	118	126	Peak
5861	58.8	58.46	68.2	-9.4	32.18	5.66	37.5	118	126	Peak
11490	41.08	44.95	54	-12.92	39.91	9.05	52.83	100	325	Average
11490	51.8	55.67	74	-22.2	39.91	9.05	52.83	100	325	Peak

REMARKS:

- Emission Level = Read Level + Antenna Factor + Cable Loss - Preamp Factor
Margin value = Emission level – Limit value
- 5745MHz: Fundamental frequency.
- 5714, 5725MHz, 5850 & 5861MHz: Out of restricted band



A D T

EUT TEST CONDITION		MEASUREMENT DETAIL	
CHANNEL	Channel 157	FREQUENCY RANGE	1GHz ~ 40GHz
INPUT POWER	120Vac, 60 Hz	DETECTOR FUNCTION	Peak (PK) Average (AV)
ENVIRONMENTAL CONDITIONS	25deg. C, 65%RH	TESTED BY	Toby Tian

ANTENNA POLARITY & TEST DISTANCE: HORIZONTAL AT 3 M

FREQ. (MHz)	EMISSION LEVEL (dBuV/m)	READ LEVEL (dBuV)	LIMIT (dBuV/m)	MARGIN (dB)	ANTENNA FACTOR (dB/m)	CABLE LOSS (dB)	PREAMP FACTOR (dB)	ANTENNA HEIGHT (cm)	TABLE ANGLE (Degree)	REMARK
5714	59.23	59.14	68.2	-8.97	31.93	5.59	37.43	100	248	Peak
5725	59.63	59.51	78.2	-18.57	31.96	5.59	37.43	100	248	Peak
5785	98.69	98.57			32.04	5.62	37.54	100	248	Average
5785	107.77	107.65			32.04	5.62	37.54	100	248	Peak
5850	59.92	59.62	78.2	-18.28	32.15	5.66	37.51	100	248	Peak
5861	59.67	59.33	68.2	-8.53	32.18	5.66	37.5	100	248	Peak
11570	40.3	44.76	54	-13.7	39.78	9.09	53.33	100	85	Average
11570	50.28	54.74	74	-23.72	39.78	9.09	53.33	100	85	Peak

ANTENNA POLARITY & TEST DISTANCE: VERTICAL AT 3 M

FREQ. (MHz)	EMISSION LEVEL (dBuV/m)	READ LEVEL (dBuV)	LIMIT (dBuV/m)	MARGIN (dB)	ANTENNA FACTOR (dB/m)	CABLE LOSS (dB)	PREAMP FACTOR (dB)	ANTENNA HEIGHT (cm)	TABLE ANGLE (Degree)	REMARK
5714	60.51	60.42	68.2	-7.69	31.93	5.59	37.43	111	146	Peak
5725	60.68	60.56	78.2	-17.52	31.96	5.59	37.43	111	146	Peak
5785	102.38	102.26			32.04	5.62	37.54	111	146	Average
5785	111.84	111.72			32.04	5.62	37.54	111	146	Peak
5850	60.38	60.08	78.2	-17.82	32.15	5.66	37.51	111	146	Peak
5861	60.14	59.8	68.2	-8.06	32.18	5.66	37.5	111	146	Peak
11570	40.54	45	54	-13.46	39.78	9.09	53.33	100	324	Average
11570	50.07	54.53	74	-23.93	39.78	9.09	53.33	100	324	Peak

REMARKS:

- Emission Level = Read Level + Antenna Factor + Cable Loss - Preamp Factor
Margin value = Emission level – Limit value
- 5785MHz: Fundamental frequency.
- 5714, 5725MHz, 5850 & 5861MHz: Out of restricted band



A D T

EUT TEST CONDITION		MEASUREMENT DETAIL	
CHANNEL	Channel 165	FREQUENCY RANGE	1GHz ~ 40GHz
INPUT POWER	120Vac, 60 Hz	DETECTOR FUNCTION	Peak (PK) Average (AV)
ENVIRONMENTAL CONDITIONS	25deg. C, 65%RH	TESTED BY	Toby Tian

ANTENNA POLARITY & TEST DISTANCE: HORIZONTAL AT 3 M

FREQ. (MHz)	EMISSION LEVEL (dBuV/m)	READ LEVEL (dBuV)	LIMIT (dBuV/m)	MARGIN (dB)	ANTENNA FACTOR (dB/m)	CABLE LOSS (dB)	PREAMP FACTOR (dB)	ANTENNA HEIGHT (cm)	TABLE ANGLE (Degree)	REMARK
5714	59.55	59.46	68.2	-8.65	31.93	5.59	37.43	100	243	Peak
5725	58.74	58.62	78.2	-19.46	31.96	5.59	37.43	100	243	Peak
5825	99.05	98.82			32.12	5.64	37.53	100	243	Average
5825	108.21	107.98			32.12	5.64	37.53	100	243	Peak
5850	70.37	70.07	78.2	-7.83	32.15	5.66	37.51	100	243	Peak
5861	64.1	63.76	68.2	-4.1	32.18	5.66	37.5	100	243	Peak
11650	41.24	45.82	54	-12.76	39.65	9.12	53.35	100	58	Average
11650	49.46	54.04	74	-24.54	39.65	9.12	53.35	100	58	Peak

ANTENNA POLARITY & TEST DISTANCE: VERTICAL AT 3 M

FREQ. (MHz)	EMISSION LEVEL (dBuV/m)	READ LEVEL (dBuV)	LIMIT (dBuV/m)	MARGIN (dB)	ANTENNA FACTOR (dB/m)	CABLE LOSS (dB)	PREAMP FACTOR (dB)	ANTENNA HEIGHT (cm)	TABLE ANGLE (Degree)	REMARK
5714	59.16	59.07	68.2	-9.04	31.93	5.59	37.43	118	122	Peak
5725	60.57	60.45	78.2	-17.63	31.96	5.59	37.43	118	122	Peak
5825	102.37	102.14			32.12	5.64	37.53	118	122	Average
5825	111.87	111.64			32.12	5.64	37.53	118	122	Peak
5850	73.22	72.92	78.2	-4.98	32.15	5.66	37.51	118	122	Peak
5861	66.15	65.81	68.2	-2.05	32.18	5.66	37.5	118	122	Peak
11650	41.33	45.91	54	-12.67	39.65	9.12	53.35	100	257	Average
11650	50.23	54.81	74	-23.77	39.65	9.12	53.35	100	257	Peak

REMARKS:

- Emission Level = Read Level + Antenna Factor + Cable Loss - Preamp Factor
Margin value = Emission level – Limit value
- 5825MHz: Fundamental frequency.
- 5714, 5725MHz, 5850 & 5861MHz: Out of restricted band



A D T

802.11n (20MHz)

EUT TEST CONDITION		MEASUREMENT DETAIL	
CHANNEL	Channel 36	FREQUENCY RANGE	1GHz ~ 40GHz
INPUT POWER	120Vac, 60 Hz	DETECTOR FUNCTION	Peak (PK) Average (AV)
ENVIRONMENTAL CONDITIONS	25deg. C, 65%RH	TESTED BY	Toby Tian

ANTENNA POLARITY & TEST DISTANCE: HORIZONTAL AT 3 M

FREQ. (MHz)	EMISSION LEVEL (dBuV/m)	READ LEVEL (dBuV)	LIMIT (dBuV/m)	MARGIN (dB)	ANTENNA FACTOR (dB/m)	CABLE LOSS (dB)	PREAMP FACTOR (dB)	ANTENNA HEIGHT (cm)	TABLE ANGLE (Degree)	REMARK
5150	44.28	44.99	54	-9.72	31.32	5.29	37.32	102	299	Average
5150	61.17	61.88	74	-12.83	31.32	5.29	37.32	102	299	Peak
5180	95.15	95.83			31.35	5.31	37.34	102	299	Average
5180	104.29	104.97			31.35	5.31	37.34	102	299	Peak
5430	38.84	39	54	-15.16	31.55	5.42	37.13	102	299	Average
5430	60.58	60.74	74	-13.42	31.55	5.42	37.13	102	299	Peak
10360	49.73	54.55	68.2	-18.47	39.19	8.13	52.14	100	223	Peak

ANTENNA POLARITY & TEST DISTANCE: VERTICAL AT 3 M

FREQ. (MHz)	EMISSION LEVEL (dBuV/m)	READ LEVEL (dBuV)	LIMIT (dBuV/m)	MARGIN (dB)	ANTENNA FACTOR (dB/m)	CABLE LOSS (dB)	PREAMP FACTOR (dB)	ANTENNA HEIGHT (cm)	TABLE ANGLE (Degree)	REMARK
5150	52.96	53.67	54	-1.32	31.32	5.29	37.32	100	185	Average
5150	70.09	70.8	74	-4.51	31.32	5.29	37.32	100	185	Peak
5180	102.46	103.14			31.35	5.31	37.34	100	185	Average
5180	110.85	111.53			31.35	5.31	37.34	100	185	Peak
5410	40.34	40.59	54	-14.55	31.52	5.41	37.18	100	185	Average
5410	60.11	60.36	74	-13.94	31.52	5.41	37.18	100	185	Peak
10360	50	54.82	68.2	-18.2	39.19	8.13	52.14	100	82	Peak

REMARKS:

- Emission Level = Read Level + Antenna Factor + Cable Loss - Preamp Factor
Margin value = Emission level – Limit value
- 5180MHz: Fundamental frequency.
- 10360MHz: Out of restricted band



A D T

EUT TEST CONDITION		MEASUREMENT DETAIL	
CHANNEL	Channel 44	FREQUENCY RANGE	1GHz ~ 40GHz
INPUT POWER	120Vac, 60 Hz	DETECTOR FUNCTION	Peak (PK) Average (AV)
ENVIRONMENTAL CONDITIONS	25deg. C, 65%RH	TESTED BY	Toby Tian

ANTENNA POLARITY & TEST DISTANCE: HORIZONTAL AT 3 M										
FREQ. (MHz)	EMISSION LEVEL (dBuV/m)	READ LEVEL (dBuV)	LIMIT (dBuV/m)	MARGIN (dB)	ANTENNA FACTOR (dB/m)	CABLE LOSS (dB)	PREAMP FACTOR (dB)	ANTENNA HEIGHT (cm)	TABLE ANGLE (Degree)	REMARK
5056	39.07	39.82	54	-14.93	31.25	5.25	37.25	103	301	Average
5056	59.93	60.68	74	-14.07	31.25	5.25	37.25	103	301	Peak
5220	98.18	98.84			31.37	5.33	37.36	103	301	Average
5220	107.16	107.82			31.37	5.33	37.36	103	301	Peak
5388	38.73	38.99	54	-15.27	31.51	5.41	37.18	103	301	Average
5388	59.86	60.12	74	-14.14	31.51	5.41	37.18	103	301	Peak
10440	50.21	55.21	68.2	-17.99	39.29	8.19	52.48	100	262	Peak
ANTENNA POLARITY & TEST DISTANCE: VERTICAL AT 3 M										
FREQ. (MHz)	EMISSION LEVEL (dBuV/m)	READ LEVEL (dBuV)	LIMIT (dBuV/m)	MARGIN (dB)	ANTENNA FACTOR (dB/m)	CABLE LOSS (dB)	PREAMP FACTOR (dB)	ANTENNA HEIGHT (cm)	TABLE ANGLE (Degree)	REMARK
5144	43.26	43.97	54	-1.32	31.32	5.29	37.32	100	192	Average
5144	61.43	62.14	74	-4.51	31.32	5.29	37.32	100	192	Peak
5220	104.68	105.34			31.37	5.33	37.36	100	192	Average
5220	113.33	113.99			31.37	5.33	37.36	100	192	Peak
5424	39.96	40.19	54	-14.55	31.53	5.42	37.18	100	192	Average
5424	60.65	60.88	74	-13.94	31.53	5.42	37.18	100	192	Peak
10438	50.43	55.43	68.2	-17.77	39.29	8.19	52.48	100	56	Peak

REMARKS:

- Emission Level = Read Level + Antenna Factor + Cable Loss - Preamp Factor
Margin value = Emission level – Limit value
- 5220MHz: Fundamental frequency.
- 10438MHz & 10440MHz: Out of restricted band



A D T

EUT TEST CONDITION		MEASUREMENT DETAIL	
CHANNEL	Channel 48	FREQUENCY RANGE	1GHz ~ 40GHz
INPUT POWER	120Vac, 60 Hz	DETECTOR FUNCTION	Peak (PK) Average (AV)
ENVIRONMENTAL CONDITIONS	25deg. C, 65%RH	TESTED BY	Toby Tian

ANTENNA POLARITY & TEST DISTANCE: HORIZONTAL AT 3 M										
FREQ. (MHz)	EMISSION LEVEL (dBuV/m)	READ LEVEL (dBuV)	LIMIT (dBuV/m)	MARGIN (dB)	ANTENNA FACTOR (dB/m)	CABLE LOSS (dB)	PREAMP FACTOR (dB)	ANTENNA HEIGHT (cm)	TABLE ANGLE (Degree)	REMARK
5034	38.48	39.25	54	-15.52	31.23	5.24	37.24	102	298	Average
5034	60.09	60.86	74	-13.91	31.23	5.24	37.24	102	298	Peak
5240	98.44	99.03			31.39	5.34	37.32	102	298	Average
5240	107.4	107.99			31.39	5.34	37.32	102	298	Peak
5350	38.76	39.07	54	-15.24	31.48	5.39	37.18	102	298	Average
5350	59.78	60.09	74	-14.22	31.48	5.39	37.18	102	298	Peak
10480	50.91	56.05	68.2	-17.29	39.37	8.2	52.71	100	346	Peak
ANTENNA POLARITY & TEST DISTANCE: VERTICAL AT 3 M										
FREQ. (MHz)	EMISSION LEVEL (dBuV/m)	READ LEVEL (dBuV)	LIMIT (dBuV/m)	MARGIN (dB)	ANTENNA FACTOR (dB/m)	CABLE LOSS (dB)	PREAMP FACTOR (dB)	ANTENNA HEIGHT (cm)	TABLE ANGLE (Degree)	REMARK
5120	40.95	41.68	54	-1.32	31.29	5.28	37.3	100	170	Average
5120	60.53	61.26	74	-4.51	31.29	5.28	37.3	100	170	Peak
5240	104.73	105.32			31.39	5.34	37.32	100	170	Average
5240	113.18	113.77			31.39	5.34	37.32	100	170	Peak
5350	40.18	40.49	54	-14.55	31.48	5.39	37.18	100	170	Average
5350	60.23	60.54	74	-13.94	31.48	5.39	37.18	100	170	Peak
10480	51.2	56.34	68.2	-17	39.37	8.2	52.71	100	14	Peak

REMARKS:

- Emission Level = Read Level + Antenna Factor + Cable Loss - Preamp Factor
Margin value = Emission level – Limit value
- 5240MHz: Fundamental frequency.
- 10480MHz: Out of restricted band



A D T

EUT TEST CONDITION		MEASUREMENT DETAIL	
CHANNEL	Channel 52	FREQUENCY RANGE	1GHz ~ 40GHz
INPUT POWER	120Vac, 60 Hz	DETECTOR FUNCTION	Peak (PK) Average (AV)
ENVIRONMENTAL CONDITIONS	25deg. C, 65%RH	TESTED BY	Toby Tian

ANTENNA POLARITY & TEST DISTANCE: HORIZONTAL AT 3 M										
FREQ. (MHz)	EMISSION LEVEL (dBuV/m)	READ LEVEL (dBuV)	LIMIT (dBuV/m)	MARGIN (dB)	ANTENNA FACTOR (dB/m)	CABLE LOSS (dB)	PREAMP FACTOR (dB)	ANTENNA HEIGHT (cm)	TABLE ANGLE (Degree)	REMARK
5102	37.79	38.52	54	-16.21	31.28	5.27	37.28	106	199	Average
5102	59.73	60.46	74	-14.27	31.28	5.27	37.28	106	199	Peak
5260	98.57	99.09			31.41	5.34	37.27	106	199	Average
5260	108.04	108.56			31.41	5.34	37.27	106	199	Peak
5420	38.36	38.59	54	-15.64	31.53	5.42	37.18	106	199	Average
5420	59.61	59.84	74	-14.39	31.53	5.42	37.18	106	199	Peak
10520	51.91	57.08	68.2	-16.29	39.43	8.23	52.83	100	82	Peak
ANTENNA POLARITY & TEST DISTANCE: VERTICAL AT 3 M										
FREQ. (MHz)	EMISSION LEVEL (dBuV/m)	READ LEVEL (dBuV)	LIMIT (dBuV/m)	MARGIN (dB)	ANTENNA FACTOR (dB/m)	CABLE LOSS (dB)	PREAMP FACTOR (dB)	ANTENNA HEIGHT (cm)	TABLE ANGLE (Degree)	REMARK
5104	39.3	40.03	54	-14.7	31.28	5.27	37.28	100	184	Average
5104	59.67	60.4	74	-14.33	31.28	5.27	37.28	100	184	Peak
5260	103.88	104.4			31.41	5.34	37.27	100	184	Average
5260	111.93	112.45			31.41	5.34	37.27	100	184	Peak
5446	40.2	40.33	54	-13.8	31.56	5.44	37.13	100	184	Average
5446	59.72	59.85	74	-14.28	31.56	5.44	37.13	100	184	Peak
10520	51.43	56.6	68.2	-16.77	39.43	8.23	52.83	100	175	Peak

REMARKS:

- Emission Level = Read Level + Antenna Factor + Cable Loss - Preamp Factor
Margin value = Emission level – Limit value
- 5260MHz: Fundamental frequency.
- 10520MHz: Out of restricted band



A D T

EUT TEST CONDITION		MEASUREMENT DETAIL	
CHANNEL	Channel 60	FREQUENCY RANGE	1GHz ~ 40GHz
INPUT POWER	120Vac, 60 Hz	DETECTOR FUNCTION	Peak (PK) Average (AV)
ENVIRONMENTAL CONDITIONS	25deg. C, 65%RH	TESTED BY	Toby Tian

ANTENNA POLARITY & TEST DISTANCE: HORIZONTAL AT 3 M										
FREQ. (MHz)	EMISSION LEVEL (dBuV/m)	READ LEVEL (dBuV)	LIMIT (dBuV/m)	MARGIN (dB)	ANTENNA FACTOR (dB/m)	CABLE LOSS (dB)	PREAMP FACTOR (dB)	ANTENNA HEIGHT (cm)	TABLE ANGLE (Degree)	REMARK
5086	37.9	38.64	54	-16.1	31.27	5.26	37.27	106	198	Average
5086	59.46	60.2	74	-14.54	31.27	5.26	37.27	106	198	Peak
5300	98.95	99.33			31.44	5.37	37.19	106	198	Average
5300	108.74	109.12			31.44	5.37	37.19	106	198	Peak
5354	43.63	43.94	54	-10.37	31.48	5.39	37.18	106	198	Average
5354	60.25	60.56	74	-13.75	31.48	5.39	37.18	106	198	Peak
10600	42.59	47.15	54	-11.41	39.57	8.28	52.41	100	232	Average
10600	51.63	56.19	74	-22.37	39.57	8.28	52.41	100	232	Peak
ANTENNA POLARITY & TEST DISTANCE: VERTICAL AT 3 M										
FREQ. (MHz)	EMISSION LEVEL (dBuV/m)	READ LEVEL (dBuV)	LIMIT (dBuV/m)	MARGIN (dB)	ANTENNA FACTOR (dB/m)	CABLE LOSS (dB)	PREAMP FACTOR (dB)	ANTENNA HEIGHT (cm)	TABLE ANGLE (Degree)	REMARK
5150	40.34	41.05	54	-13.66	31.32	5.29	37.32	100	186	Average
5150	60.34	61.05	74	-13.66	31.32	5.29	37.32	100	186	Peak
5300	103.99	104.37			31.44	5.37	37.19	100	186	Average
5300	112.51	112.89			31.44	5.37	37.19	100	186	Peak
5350	47.4	47.71	54	-6.6	31.48	5.39	37.18	100	186	Average
5350	64.14	64.45	74	-9.86	31.48	5.39	37.18	100	186	Peak
10600	42.25	46.81	54	-11.75	39.57	8.28	52.41	100	145	Average
10600	52.4	56.96	74	-21.6	39.57	8.28	52.41	100	145	Peak

REMARKS:

- Emission Level = Read Level + Antenna Factor + Cable Loss - Preamp Factor
Margin value = Emission level – Limit value
- 5300MHz: Fundamental frequency.



A D T

EUT TEST CONDITION		MEASUREMENT DETAIL	
CHANNEL	Channel 64	FREQUENCY RANGE	1GHz ~ 40GHz
INPUT POWER	120Vac, 60 Hz	DETECTOR FUNCTION	Peak (PK) Average (AV)
ENVIRONMENTAL CONDITIONS	25deg. C, 65%RH	TESTED BY	Toby Tian

ANTENNA POLARITY & TEST DISTANCE: HORIZONTAL AT 3 M										
FREQ. (MHz)	EMISSION LEVEL (dBuV/m)	READ LEVEL (dBuV)	LIMIT (dBuV/m)	MARGIN (dB)	ANTENNA FACTOR (dB/m)	CABLE LOSS (dB)	PREAMP FACTOR (dB)	ANTENNA HEIGHT (cm)	TABLE ANGLE (Degree)	REMARK
5148	37.78	38.49	54	-16.22	31.32	5.29	37.32	104	192	Average
5148	59.64	60.35	74	-14.36	31.32	5.29	37.32	104	192	Peak
5320	97.34	97.7			31.45	5.38	37.19	104	192	Average
5320	107.45	107.81			31.45	5.38	37.19	104	192	Peak
5350	48.11	48.42	54	-5.89	31.48	5.39	37.18	104	192	Average
5350	67.93	68.24	74	-6.07	31.48	5.39	37.18	104	192	Peak
10640	42.05	46.38	54	-11.95	39.62	8.32	52.27	100	266	Average
10640	53.13	57.46	74	-20.87	39.62	8.32	52.27	100	266	Peak
ANTENNA POLARITY & TEST DISTANCE: VERTICAL AT 3 M										
FREQ. (MHz)	EMISSION LEVEL (dBuV/m)	READ LEVEL (dBuV)	LIMIT (dBuV/m)	MARGIN (dB)	ANTENNA FACTOR (dB/m)	CABLE LOSS (dB)	PREAMP FACTOR (dB)	ANTENNA HEIGHT (cm)	TABLE ANGLE (Degree)	REMARK
5006	39.23	40.03	54	-14.77	31.21	5.22	37.23	100	183	Average
5006	59.67	60.47	74	-14.33	31.21	5.22	37.23	100	183	Peak
5320	102.44	102.8			31.45	5.38	37.19	100	183	Average
5320	110.41	110.77			31.45	5.38	37.19	100	183	Peak
5350	52.27	52.58	54	-1.73	31.48	5.39	37.18	100	183	Average
5350	68.97	69.28	74	-5.03	31.48	5.39	37.18	100	183	Peak
10640	41.92	46.25	54	-12.08	39.62	8.32	52.27	100	61	Average
10640	53.32	57.65	74	-20.68	39.62	8.32	52.27	100	61	Peak

REMARKS:

- Emission Level = Read Level + Antenna Factor + Cable Loss - Preamp Factor
Margin value = Emission level – Limit value
- 5320MHz: Fundamental frequency.



A D T

EUT TEST CONDITION		MEASUREMENT DETAIL	
CHANNEL	Channel 100	FREQUENCY RANGE	1GHz ~ 40GHz
INPUT POWER	120Vac, 60 Hz	DETECTOR FUNCTION	Peak (PK) Average (AV)
ENVIRONMENTAL CONDITIONS	25deg. C, 65%RH	TESTED BY	Toby Tian

ANTENNA POLARITY & TEST DISTANCE: HORIZONTAL AT 3 M										
FREQ. (MHz)	EMISSION LEVEL (dBuV/m)	READ LEVEL (dBuV)	LIMIT (dBuV/m)	MARGIN (dB)	ANTENNA FACTOR (dB/m)	CABLE LOSS (dB)	PREAMP FACTOR (dB)	ANTENNA HEIGHT (cm)	TABLE ANGLE (Degree)	REMARK
5460	45.59	45.67	54	-8.41	31.56	5.44	37.08	121	247	Average
5460	63.4	63.48	74	-10.6	31.56	5.44	37.08	121	247	Peak
5470	66.83	66.89	68.2	-1.37	31.57	5.45	37.08	121	247	Peak
5500	99.45	99.42			31.6	5.46	37.03	121	247	Average
5500	109.15	109.12			31.6	5.46	37.03	121	247	Peak
5725	57.74	57.62	68.2	-10.46	31.96	5.59	37.43	121	247	Peak
11000	41.52	46.21	54	-12.48	40.2	8.56	53.45	100	109	Average
11000	51.42	56.11	74	-22.58	40.2	8.56	53.45	100	109	Peak
ANTENNA POLARITY & TEST DISTANCE: VERTICAL AT 3 M										
FREQ. (MHz)	EMISSION LEVEL (dBuV/m)	READ LEVEL (dBuV)	LIMIT (dBuV/m)	MARGIN (dB)	ANTENNA FACTOR (dB/m)	CABLE LOSS (dB)	PREAMP FACTOR (dB)	ANTENNA HEIGHT (cm)	TABLE ANGLE (Degree)	REMARK
5460	45.59	45.67	54	-8.41	31.56	5.44	37.08	113	207	Average
5460	61.21	61.29	74	-12.79	31.56	5.44	37.08	113	207	Peak
5470	64	64.06	68.2	-4.2	31.57	5.45	37.08	113	207	Peak
5500	95.5	95.47			31.6	5.46	37.03	113	207	Average
5500	105.23	105.2			31.6	5.46	37.03	113	207	Peak
5725	58.39	58.27	68.2	-9.81	31.96	5.59	37.43	113	207	Peak
11000	41.14	45.83	54	-12.86	40.2	8.56	53.45	100	326	Average
11000	51.59	56.28	74	-22.41	40.2	8.56	53.45	100	326	Peak

REMARKS:

- Emission Level = Read Level + Antenna Factor + Cable Loss - Preamp Factor
Margin value = Emission level – Limit value
- 5500MHz: Fundamental frequency.
- 5470MHz & 5725MHz: Out of restricted band



A D T

EUT TEST CONDITION		MEASUREMENT DETAIL	
CHANNEL	Channel 116	FREQUENCY RANGE	1GHz ~ 40GHz
INPUT POWER	120Vac, 60 Hz	DETECTOR FUNCTION	Peak (PK) Average (AV)
ENVIRONMENTAL CONDITIONS	25deg. C, 65%RH	TESTED BY	Toby Tian

ANTENNA POLARITY & TEST DISTANCE: HORIZONTAL AT 3 M										
FREQ. (MHz)	EMISSION LEVEL (dBuV/m)	READ LEVEL (dBuV)	LIMIT (dBuV/m)	MARGIN (dB)	ANTENNA FACTOR (dB/m)	CABLE LOSS (dB)	PREAMP FACTOR (dB)	ANTENNA HEIGHT (cm)	TABLE ANGLE (Degree)	REMARK
5406	38.57	38.82	54	-15.43	31.52	5.41	37.18	113	245	Average
5406	58.93	59.18	74	-15.07	31.52	5.41	37.18	113	245	Peak
5470	59.32	59.38	68.2	-8.88	31.57	5.45	37.08	113	245	Peak
5580	102.03	101.98			31.71	5.5	37.16	113	245	Average
5580	112.1	112.05			31.71	5.5	37.16	113	245	Peak
5725	58.24	58.12	68.2	-9.96	31.96	5.59	37.43	113	245	Peak
11160	42.04	46.62	54	-11.96	40.1	8.71	53.39	100	284	Average
11160	53.83	58.41	74	-20.17	40.1	8.71	53.39	100	284	Peak
ANTENNA POLARITY & TEST DISTANCE: VERTICAL AT 3 M										
FREQ. (MHz)	EMISSION LEVEL (dBuV/m)	READ LEVEL (dBuV)	LIMIT (dBuV/m)	MARGIN (dB)	ANTENNA FACTOR (dB/m)	CABLE LOSS (dB)	PREAMP FACTOR (dB)	ANTENNA HEIGHT (cm)	TABLE ANGLE (Degree)	REMARK
5386	37.64	37.91	54	-16.36	31.51	5.4	37.18	114	273	Average
5386	59.53	59.8	74	-14.47	31.51	5.4	37.18	114	273	Peak
5470	57.64	57.7	68.2	-10.56	31.57	5.45	37.08	114	273	Peak
5580	99.07	99.02			31.71	5.5	37.16	114	273	Average
5580	108.29	108.24			31.71	5.5	37.16	114	273	Peak
5725	58.38	58.26	68.2	-9.82	31.96	5.59	37.43	114	273	Peak
11160	41.68	46.26	54	-12.32	40.1	8.71	53.39	100	129	Average
11160	52.57	57.15	74	-21.43	40.1	8.71	53.39	100	129	Peak

REMARKS:

- Emission Level = Read Level + Antenna Factor + Cable Loss - Preamp Factor
Margin value = Emission level – Limit value
- 5580MHz: Fundamental frequency.
- 5470MHz & 5725MHz: Out of restricted band



A D T

EUT TEST CONDITION		MEASUREMENT DETAIL	
CHANNEL	Channel 120	FREQUENCY RANGE	1GHz ~ 40GHz
INPUT POWER	120Vac, 60 Hz	DETECTOR FUNCTION	Peak (PK) Average (AV)
ENVIRONMENTAL CONDITIONS	25deg. C, 65%RH	TESTED BY	Toby Tian

ANTENNA POLARITY & TEST DISTANCE: HORIZONTAL AT 3 M										
FREQ. (MHz)	EMISSION LEVEL (dBuV/m)	READ LEVEL (dBuV)	LIMIT (dBuV/m)	MARGIN (dB)	ANTENNA FACTOR (dB/m)	CABLE LOSS (dB)	PREAMP FACTOR (dB)	ANTENNA HEIGHT (cm)	TABLE ANGLE (Degree)	REMARK
5372	40.04	40.33	54	-13.96	31.49	5.4	37.18	122	245	Average
5372	60.32	60.61	74	-13.68	31.49	5.4	37.18	122	245	Peak
5470	59.01	59.07	68.2	-9.19	31.57	5.45	37.08	122	245	Peak
5600	104.75	104.62			31.77	5.52	37.16	122	245	Average
5600	113.03	112.9			31.77	5.52	37.16	122	245	Peak
5725	60.13	60.01	68.2	-8.07	31.96	5.59	37.43	122	245	Peak
11200	41.78	46.1	54	-12.22	40.08	8.76	53.16	100	274	Average
11200	51.91	56.23	74	-22.09	40.08	8.76	53.16	100	274	Peak
ANTENNA POLARITY & TEST DISTANCE: VERTICAL AT 3 M										
FREQ. (MHz)	EMISSION LEVEL (dBuV/m)	READ LEVEL (dBuV)	LIMIT (dBuV/m)	MARGIN (dB)	ANTENNA FACTOR (dB/m)	CABLE LOSS (dB)	PREAMP FACTOR (dB)	ANTENNA HEIGHT (cm)	TABLE ANGLE (Degree)	REMARK
5348	39.17	39.48	54	-14.83	31.48	5.39	37.18	100	212	Average
5348	60.77	61.08	74	-13.23	31.48	5.39	37.18	100	212	Peak
5470	59.47	59.53	68.2	-8.73	31.57	5.45	37.08	100	212	Peak
5600	101.09	100.96			31.77	5.52	37.16	100	212	Average
5600	111.27	111.14			31.77	5.52	37.16	100	212	Peak
5725	59.09	58.97	68.2	-9.11	31.96	5.59	37.43	100	212	Peak
11200	41.67	45.99	54	-12.33	40.08	8.76	53.16	100	113	Average
11200	54.27	58.59	74	-19.73	40.08	8.76	53.16	100	113	Peak

REMARKS:

- Emission Level = Read Level + Antenna Factor + Cable Loss - Preamp Factor
Margin value = Emission level – Limit value
- 5600MHz: Fundamental frequency.
- 5470MHz & 5725MHz: Out of restricted band



A D T

EUT TEST CONDITION		MEASUREMENT DETAIL	
CHANNEL	Channel 140	FREQUENCY RANGE	1GHz ~ 40GHz
INPUT POWER	120Vac, 60 Hz	DETECTOR FUNCTION	Peak (PK) Average (AV)
ENVIRONMENTAL CONDITIONS	25deg. C, 65%RH	TESTED BY	Toby Tian

ANTENNA POLARITY & TEST DISTANCE: HORIZONTAL AT 3 M

FREQ. (MHz)	EMISSION LEVEL (dBuV/m)	READ LEVEL (dBuV)	LIMIT (dBuV/m)	MARGIN (dB)	ANTENNA FACTOR (dB/m)	CABLE LOSS (dB)	PREAMP FACTOR (dB)	ANTENNA HEIGHT (cm)	TABLE ANGLE (Degree)	REMARK
5372	38.68	38.97	54	-15.32	31.49	5.4	37.18	121	249	Average
5372	59.67	59.96	74	-14.33	31.49	5.4	37.18	121	249	Peak
5470	59.27	59.33	68.2	-8.93	31.57	5.45	37.08	121	249	Peak
5700	99.33	99.26			31.9	5.57	37.4	121	249	Average
5700	108.68	108.61			31.9	5.57	37.4	121	249	Peak
5725	66.64	66.52	68.2	-1.56	31.96	5.59	37.43	121	249	Peak
11400	43.61	46.83	54	-10.39	39.96	8.95	52.13	100	168	Average
11400	53.51	56.73	74	-20.49	39.96	8.95	52.13	100	168	Peak

ANTENNA POLARITY & TEST DISTANCE: VERTICAL AT 3 M

FREQ. (MHz)	EMISSION LEVEL (dBuV/m)	READ LEVEL (dBuV)	LIMIT (dBuV/m)	MARGIN (dB)	ANTENNA FACTOR (dB/m)	CABLE LOSS (dB)	PREAMP FACTOR (dB)	ANTENNA HEIGHT (cm)	TABLE ANGLE (Degree)	REMARK
5400	37.68	37.93	54	-16.32	31.52	5.41	37.18	112	262	Average
5400	60.36	60.61	74	-13.64	31.52	5.41	37.18	112	262	Peak
5470	58.47	58.53	68.2	-9.73	31.57	5.45	37.08	112	262	Peak
5700	96.1	96.03			31.9	5.57	37.4	112	262	Average
5700	105.67	105.6			31.9	5.57	37.4	112	262	Peak
5725	65.43	65.31	68.2	-2.77	31.96	5.59	37.43	112	262	Peak
11400	42.59	45.81	54	-11.41	39.96	8.95	52.13	100	227	Average
11400	54.01	57.23	74	-19.99	39.96	8.95	52.13	100	227	Peak

REMARKS:

- Emission Level = Read Level + Antenna Factor + Cable Loss - Preamp Factor
Margin value = Emission level – Limit value
- 5700MHz: Fundamental frequency.
- 5470MHz & 5725MHz: Out of restricted band



A D T

EUT TEST CONDITION		MEASUREMENT DETAIL	
CHANNEL	Channel 149	FREQUENCY RANGE	1GHz ~ 40GHz
INPUT POWER	120Vac, 60 Hz	DETECTOR FUNCTION	Peak (PK) Average (AV)
ENVIRONMENTAL CONDITIONS	25deg. C, 65%RH	TESTED BY	Toby Tian

ANTENNA POLARITY & TEST DISTANCE: HORIZONTAL AT 3 M

FREQ. (MHz)	EMISSION LEVEL (dBuV/m)	READ LEVEL (dBuV)	LIMIT (dBuV/m)	MARGIN (dB)	ANTENNA FACTOR (dB/m)	CABLE LOSS (dB)	PREAMP FACTOR (dB)	ANTENNA HEIGHT (cm)	TABLE ANGLE (Degree)	REMARK
5714	62.38	62.29	68.2	-5.82	31.93	5.59	37.43	100	247	Peak
5725	72.2	72.08	78.2	-6	31.96	5.59	37.43	100	247	Peak
5745	96.02	95.9			31.99	5.6	37.47	100	247	Average
5745	105.58	105.46			31.99	5.6	37.47	100	247	Peak
5850	59.7	59.4	78.2	-18.5	32.15	5.66	37.51	100	247	Peak
5861	60.41	60.07	68.2	-7.79	32.18	5.66	37.5	100	247	Peak
11490	40.92	44.79	54	-13.08	39.91	9.05	52.83	100	92	Average
11490	52.4	56.27	74	-21.6	39.91	9.05	52.83	100	92	Peak

ANTENNA POLARITY & TEST DISTANCE: VERTICAL AT 3 M

FREQ. (MHz)	EMISSION LEVEL (dBuV/m)	READ LEVEL (dBuV)	LIMIT (dBuV/m)	MARGIN (dB)	ANTENNA FACTOR (dB/m)	CABLE LOSS (dB)	PREAMP FACTOR (dB)	ANTENNA HEIGHT (cm)	TABLE ANGLE (Degree)	REMARK
5714	64.79	64.7	68.2	-3.41	31.93	5.59	37.43	102	159	Peak
5725	73.79	73.67	78.2	-4.41	31.96	5.59	37.43	102	159	Peak
5745	100.16	100.04			31.99	5.6	37.47	102	159	Average
5745	109.93	109.81			31.99	5.6	37.47	102	159	Peak
5850	59.12	58.82	78.2	-19.08	32.15	5.66	37.51	102	159	Peak
5861	59.15	58.81	68.2	-9.05	32.18	5.66	37.5	102	159	Peak
11490	40.94	44.81	54	-13.06	39.91	9.05	52.83	100	306	Average
11490	50.69	54.56	74	-23.31	39.91	9.05	52.83	100	306	Peak

REMARKS:

- Emission Level = Read Level + Antenna Factor + Cable Loss - Preamp Factor
Margin value = Emission level – Limit value
- 5745MHz: Fundamental frequency.
- 5714, 5725MHz, 5850 & 5861MHz: Out of restricted band



A D T

EUT TEST CONDITION		MEASUREMENT DETAIL	
CHANNEL	Channel 157	FREQUENCY RANGE	1GHz ~ 40GHz
INPUT POWER	120Vac, 60 Hz	DETECTOR FUNCTION	Peak (PK) Average (AV)
ENVIRONMENTAL CONDITIONS	25deg. C, 65%RH	TESTED BY	Toby Tian

ANTENNA POLARITY & TEST DISTANCE: HORIZONTAL AT 3 M

FREQ. (MHz)	EMISSION LEVEL (dBuV/m)	READ LEVEL (dBuV)	LIMIT (dBuV/m)	MARGIN (dB)	ANTENNA FACTOR (dB/m)	CABLE LOSS (dB)	PREAMP FACTOR (dB)	ANTENNA HEIGHT (cm)	TABLE ANGLE (Degree)	REMARK
5714	58.93	58.84	68.2	-9.27	31.93	5.59	37.43	100	249	Peak
5725	60.26	60.14	78.2	-17.94	31.96	5.59	37.43	100	249	Peak
5785	98.15	98.03			32.04	5.62	37.54	100	249	Average
5785	107.92	107.8			32.04	5.62	37.54	100	249	Peak
5850	60.91	60.61	78.2	-17.29	32.15	5.66	37.51	100	249	Peak
5861	60.11	59.77	68.2	-8.09	32.18	5.66	37.5	100	249	Peak
11570	40.11	44.57	54	-13.89	39.78	9.09	53.33	100	38	Average
11570	49.78	54.24	74	-24.22	39.78	9.09	53.33	100	38	Peak

ANTENNA POLARITY & TEST DISTANCE: VERTICAL AT 3 M

FREQ. (MHz)	EMISSION LEVEL (dBuV/m)	READ LEVEL (dBuV)	LIMIT (dBuV/m)	MARGIN (dB)	ANTENNA FACTOR (dB/m)	CABLE LOSS (dB)	PREAMP FACTOR (dB)	ANTENNA HEIGHT (cm)	TABLE ANGLE (Degree)	REMARK
5714	60.84	60.75	68.2	-7.36	31.93	5.59	37.43	111	150	Peak
5725	59.85	59.73	78.2	-18.35	31.96	5.59	37.43	111	150	Peak
5785	102.01	101.89			32.04	5.62	37.54	111	150	Average
5785	111.56	111.44			32.04	5.62	37.54	111	150	Peak
5850	61.69	61.39	78.2	-16.51	32.15	5.66	37.51	111	150	Peak
5861	60.56	60.22	68.2	-7.64	32.18	5.66	37.5	111	150	Peak
11570	40.44	44.9	54	-13.56	39.78	9.09	53.33	100	241	Average
11570	50.42	54.88	74	-23.58	39.78	9.09	53.33	100	241	Peak

REMARKS:

- Emission Level = Read Level + Antenna Factor + Cable Loss - Preamp Factor
Margin value = Emission level – Limit value
- 5785MHz: Fundamental frequency.
- 5714, 5725MHz, 5850 & 5861MHz: Out of restricted band



A D T

EUT TEST CONDITION		MEASUREMENT DETAIL	
CHANNEL	Channel 165	FREQUENCY RANGE	1GHz ~ 40GHz
INPUT POWER	120Vac, 60 Hz	DETECTOR FUNCTION	Peak (PK) Average (AV)
ENVIRONMENTAL CONDITIONS	25deg. C, 65%RH	TESTED BY	Toby Tian

ANTENNA POLARITY & TEST DISTANCE: HORIZONTAL AT 3 M

FREQ. (MHz)	EMISSION LEVEL (dBuV/m)	READ LEVEL (dBuV)	LIMIT (dBuV/m)	MARGIN (dB)	ANTENNA FACTOR (dB/m)	CABLE LOSS (dB)	PREAMP FACTOR (dB)	ANTENNA HEIGHT (cm)	TABLE ANGLE (Degree)	REMARK
5714	60.09	60	68.2	-8.11	31.93	5.59	37.43	100	244	Peak
5725	59.25	59.13	78.2	-18.95	31.96	5.59	37.43	100	244	Peak
5825	98.36	98.13			32.12	5.64	37.53	100	244	Average
5825	107.92	107.69			32.12	5.64	37.53	100	244	Peak
5850	69.21	68.91	78.2	-8.99	32.15	5.66	37.51	100	244	Peak
5861	64.08	63.74	68.2	-4.12	32.18	5.66	37.5	100	244	Peak
11650	41.2	45.78	54	-12.8	39.65	9.12	53.35	100	158	Average
11650	50.7	55.28	74	-23.3	39.65	9.12	53.35	100	158	Peak

ANTENNA POLARITY & TEST DISTANCE: VERTICAL AT 3 M

FREQ. (MHz)	EMISSION LEVEL (dBuV/m)	READ LEVEL (dBuV)	LIMIT (dBuV/m)	MARGIN (dB)	ANTENNA FACTOR (dB/m)	CABLE LOSS (dB)	PREAMP FACTOR (dB)	ANTENNA HEIGHT (cm)	TABLE ANGLE (Degree)	REMARK
5714	59.56	59.47	68.2	-8.64	31.93	5.59	37.43	101	151	Peak
5725	59.69	59.57	78.2	-18.51	31.96	5.59	37.43	101	151	Peak
5825	101.55	101.32			32.12	5.64	37.53	101	151	Average
5825	111.32	111.09			32.12	5.64	37.53	101	151	Peak
5850	71	70.7	78.2	-7.2	32.15	5.66	37.51	101	151	Peak
5861	65.54	65.2	68.2	-2.66	32.18	5.66	37.5	101	151	Peak
11650	41.25	45.83	54	-12.75	39.65	9.12	53.35	100	279	Average
11650	50.16	54.74	74	-23.84	39.65	9.12	53.35	100	279	Peak

REMARKS:

- Emission Level = Read Level + Antenna Factor + Cable Loss - Preamp Factor
Margin value = Emission level – Limit value
- 5825MHz: Fundamental frequency.
- 5714, 5725MHz, 5850 & 5861MHz: Out of restricted band



A D T

Mode B

802.11a

EUT TEST CONDITION		MEASUREMENT DETAIL	
CHANNEL	Channel 36	FREQUENCY RANGE	1GHz ~ 40GHz
INPUT POWER	120Vac, 60 Hz	DETECTOR FUNCTION	Peak (PK) Average (AV)
ENVIRONMENTAL CONDITIONS	25deg. C, 65%RH	TESTED BY	Toby Tian

ANTENNA POLARITY & TEST DISTANCE: HORIZONTAL AT 3 M

FREQ. (MHz)	EMISSION LEVEL (dBuV/m)	READ LEVEL (dBuV)	LIMIT (dBuV/m)	MARGIN (dB)	ANTENNA FACTOR (dB/m)	CABLE LOSS (dB)	PREAMP FACTOR (dB)	ANTENNA HEIGHT (cm)	TABLE ANGLE (Degree)	REMARK
5146	48.74	49.45	54	-5.26	31.32	5.29	37.32	105	199	Average
5146	64.74	65.45	74	-9.26	31.32	5.29	37.32	105	199	Peak
5180	99.87	100.55			31.35	5.31	37.34	105	199	Average
5180	108.82	109.5			31.35	5.31	37.34	105	199	Peak
5408	38.72	38.97	54	-15.28	31.52	5.41	37.18	105	199	Average
5408	60.35	60.6	74	-13.65	31.52	5.41	37.18	105	199	Peak
10360	50.43	55.25	68.2	-17.77	39.19	8.13	52.14	100	264	Peak

ANTENNA POLARITY & TEST DISTANCE: VERTICAL AT 3 M

FREQ. (MHz)	EMISSION LEVEL (dBuV/m)	READ LEVEL (dBuV)	LIMIT (dBuV/m)	MARGIN (dB)	ANTENNA FACTOR (dB/m)	CABLE LOSS (dB)	PREAMP FACTOR (dB)	ANTENNA HEIGHT (cm)	TABLE ANGLE (Degree)	REMARK
5150	52.92	53.63	54	-1.08	31.32	5.29	37.32	100	154	Average
5150	70.79	71.5	74	-3.21	31.32	5.29	37.32	100	154	Peak
5180	103.96	104.64			31.35	5.31	37.34	100	154	Average
5180	111.78	112.46			31.35	5.31	37.34	100	154	Peak
5426	39.5	39.68	54	-14.5	31.53	5.42	37.13	100	154	Average
5426	60.45	60.63	74	-13.55	31.53	5.42	37.13	100	154	Peak
10360	50.55	55.37	68.2	-17.65	39.19	8.13	52.14	100	119	Peak

REMARKS:

- Emission Level = Read Level + Antenna Factor + Cable Loss - Preamp Factor
Margin value = Emission level – Limit value
- 5180MHz: Fundamental frequency.
- 10360MHz: Out of restricted band



A D T

EUT TEST CONDITION		MEASUREMENT DETAIL	
CHANNEL	Channel 44	FREQUENCY RANGE	1GHz ~ 40GHz
INPUT POWER	120Vac, 60 Hz	DETECTOR FUNCTION	Peak (PK) Average (AV)
ENVIRONMENTAL CONDITIONS	25deg. C, 65%RH	TESTED BY	Toby Tian

ANTENNA POLARITY & TEST DISTANCE: HORIZONTAL AT 3 M										
FREQ. (MHz)	EMISSION LEVEL (dBuV/m)	READ LEVEL (dBuV)	LIMIT (dBuV/m)	MARGIN (dB)	ANTENNA FACTOR (dB/m)	CABLE LOSS (dB)	PREAMP FACTOR (dB)	ANTENNA HEIGHT (cm)	TABLE ANGLE (Degree)	REMARK
5016	39.87	40.65	54	-14.13	31.21	5.24	37.23	105	201	Average
5016	60.63	61.41	74	-13.37	31.21	5.24	37.23	105	201	Peak
5220	100.82	101.48			31.37	5.33	37.36	105	201	Average
5220	109.7	110.36			31.37	5.33	37.36	105	201	Peak
5424	38.8	39.03	54	-15.2	31.53	5.42	37.18	105	201	Average
5424	60.57	60.8	74	-13.43	31.53	5.42	37.18	105	201	Peak
10440	49.94	54.94	68.2	-18.26	39.29	8.19	52.48	100	288	Peak
ANTENNA POLARITY & TEST DISTANCE: VERTICAL AT 3 M										
FREQ. (MHz)	EMISSION LEVEL (dBuV/m)	READ LEVEL (dBuV)	LIMIT (dBuV/m)	MARGIN (dB)	ANTENNA FACTOR (dB/m)	CABLE LOSS (dB)	PREAMP FACTOR (dB)	ANTENNA HEIGHT (cm)	TABLE ANGLE (Degree)	REMARK
5130	42.27	42.98	54	-11.73	31.31	5.28	37.3	100	159	Average
5130	61.14	61.85	74	-12.86	31.31	5.28	37.3	100	159	Peak
5220	104.86	105.52			31.37	5.33	37.36	100	159	Average
5220	112.37	113.03			31.37	5.33	37.36	100	159	Peak
5424	40.5	40.73	54	-13.5	31.53	5.42	37.18	100	159	Average
5424	60.22	60.45	74	-13.78	31.53	5.42	37.18	100	159	Peak
10440	50.49	55.49	68.2	-17.71	39.29	8.19	52.48	100	62	Peak

REMARKS:

- Emission Level = Read Level + Antenna Factor + Cable Loss - Preamp Factor
Margin value = Emission level – Limit value
- 5220MHz: Fundamental frequency.
- 10440MHz: Out of restricted band



A D T

EUT TEST CONDITION		MEASUREMENT DETAIL	
CHANNEL	Channel 48	FREQUENCY RANGE	1GHz ~ 40GHz
INPUT POWER	120Vac, 60 Hz	DETECTOR FUNCTION	Peak (PK) Average (AV)
ENVIRONMENTAL CONDITIONS	25deg. C, 65%RH	TESTED BY	Toby Tian

ANTENNA POLARITY & TEST DISTANCE: HORIZONTAL AT 3 M										
FREQ. (MHz)	EMISSION LEVEL (dBuV/m)	READ LEVEL (dBuV)	LIMIT (dBuV/m)	MARGIN (dB)	ANTENNA FACTOR (dB/m)	CABLE LOSS (dB)	PREAMP FACTOR (dB)	ANTENNA HEIGHT (cm)	TABLE ANGLE (Degree)	REMARK
5126	39.38	40.09	54	-14.62	31.31	5.28	37.3	104	209	Average
5126	60.18	60.89	74	-13.82	31.31	5.28	37.3	104	209	Peak
5240	100.12	100.71			31.39	5.34	37.32	104	209	Average
5240	109.38	109.97			31.39	5.34	37.32	104	209	Peak
5420	38.84	39.07	54	-15.16	31.53	5.42	37.18	104	209	Average
5420	60.55	60.78	74	-13.45	31.53	5.42	37.18	104	209	Peak
10480	51.95	57.09	68.2	-16.25	39.37	8.2	52.71	100	240	Peak
ANTENNA POLARITY & TEST DISTANCE: VERTICAL AT 3 M										
FREQ. (MHz)	EMISSION LEVEL (dBuV/m)	READ LEVEL (dBuV)	LIMIT (dBuV/m)	MARGIN (dB)	ANTENNA FACTOR (dB/m)	CABLE LOSS (dB)	PREAMP FACTOR (dB)	ANTENNA HEIGHT (cm)	TABLE ANGLE (Degree)	REMARK
5098	40.94	41.67	54	-13.06	31.28	5.27	37.28	100	162	Average
5098	60.05	60.78	74	-13.95	31.28	5.27	37.28	100	162	Peak
5240	104.87	105.46			31.39	5.34	37.32	100	162	Average
5240	112.66	113.25			31.39	5.34	37.32	100	162	Peak
5352	39.86	40.17	54	-14.14	31.48	5.39	37.18	100	162	Average
5352	60.6	60.91	74	-13.4	31.48	5.39	37.18	100	162	Peak
10480	51.98	57.12	68.2	-16.22	39.37	8.2	52.71	100	84	Peak

REMARKS:

- Emission Level = Read Level + Antenna Factor + Cable Loss - Preamp Factor
Margin value = Emission level – Limit value
- 5240MHz: Fundamental frequency.
- 10480MHz: Out of restricted band



A D T

EUT TEST CONDITION		MEASUREMENT DETAIL	
CHANNEL	Channel 52	FREQUENCY RANGE	1GHz ~ 40GHz
INPUT POWER	120Vac, 60 Hz	DETECTOR FUNCTION	Peak (PK) Average (AV)
ENVIRONMENTAL CONDITIONS	25deg. C, 65%RH	TESTED BY	Toby Tian

ANTENNA POLARITY & TEST DISTANCE: HORIZONTAL AT 3 M										
FREQ. (MHz)	EMISSION LEVEL (dBuV/m)	READ LEVEL (dBuV)	LIMIT (dBuV/m)	MARGIN (dB)	ANTENNA FACTOR (dB/m)	CABLE LOSS (dB)	PREAMP FACTOR (dB)	ANTENNA HEIGHT (cm)	TABLE ANGLE (Degree)	REMARK
5108	39.28	40	54	-14.72	31.29	5.27	37.28	105	202	Average
5108	59.9	60.62	74	-14.1	31.29	5.27	37.28	105	202	Peak
5260	98.88	99.4			31.41	5.34	37.27	105	202	Average
5260	108.31	108.83			31.41	5.34	37.27	105	202	Peak
5448	38.83	38.96	54	-15.17	31.56	5.44	37.13	105	202	Average
5448	59.67	59.8	74	-14.33	31.56	5.44	37.13	105	202	Peak
10520	47.81	52.98	68.2	-20.39	39.43	8.23	52.83	100	172	Peak
ANTENNA POLARITY & TEST DISTANCE: VERTICAL AT 3 M										
FREQ. (MHz)	EMISSION LEVEL (dBuV/m)	READ LEVEL (dBuV)	LIMIT (dBuV/m)	MARGIN (dB)	ANTENNA FACTOR (dB/m)	CABLE LOSS (dB)	PREAMP FACTOR (dB)	ANTENNA HEIGHT (cm)	TABLE ANGLE (Degree)	REMARK
5148	39.81	40.52	54	-14.19	31.32	5.29	37.32	100	186	Average
5148	59.84	60.55	74	-14.16	31.32	5.29	37.32	100	186	Peak
5260	103.15	103.67			31.41	5.34	37.27	100	186	Average
5260	111.71	112.23			31.41	5.34	37.27	100	186	Peak
5392	40.94	41.2	54	-13.06	31.51	5.41	37.18	100	186	Average
5392	60.11	60.37	74	-13.89	31.51	5.41	37.18	100	186	Peak
10520	48.02	53.19	68.2	-20.18	39.43	8.23	52.83	100	108	Peak

REMARKS:

- Emission Level = Read Level + Antenna Factor + Cable Loss - Preamp Factor
Margin value = Emission level – Limit value
- 5260MHz: Fundamental frequency.
- 10520MHz: Out of restricted band



A D T

EUT TEST CONDITION		MEASUREMENT DETAIL	
CHANNEL	Channel 60	FREQUENCY RANGE	1GHz ~ 40GHz
INPUT POWER	120Vac, 60 Hz	DETECTOR FUNCTION	Peak (PK) Average (AV)
ENVIRONMENTAL CONDITIONS	25deg. C, 65%RH	TESTED BY	Toby Tian

ANTENNA POLARITY & TEST DISTANCE: HORIZONTAL AT 3 M										
FREQ. (MHz)	EMISSION LEVEL (dBuV/m)	READ LEVEL (dBuV)	LIMIT (dBuV/m)	MARGIN (dB)	ANTENNA FACTOR (dB/m)	CABLE LOSS (dB)	PREAMP FACTOR (dB)	ANTENNA HEIGHT (cm)	TABLE ANGLE (Degree)	REMARK
5148	38.57	39.28	54	-15.43	31.32	5.29	37.32	103	203	Average
5148	59.81	60.52	74	-14.19	31.32	5.29	37.32	103	203	Peak
5300	98.65	99.03			31.44	5.37	37.19	103	203	Average
5300	108.15	108.53			31.44	5.37	37.19	103	203	Peak
5350	42.43	42.74	54	-11.57	31.48	5.39	37.18	103	203	Average
5350	61.18	61.49	74	-12.82	31.48	5.39	37.18	103	203	Peak
10600	41.3	45.86	54	-12.7	39.57	8.28	52.41	100	172	Average
10600	50.25	54.81	74	-23.75	39.57	8.28	52.41	100	172	Peak
ANTENNA POLARITY & TEST DISTANCE: VERTICAL AT 3 M										
FREQ. (MHz)	EMISSION LEVEL (dBuV/m)	READ LEVEL (dBuV)	LIMIT (dBuV/m)	MARGIN (dB)	ANTENNA FACTOR (dB/m)	CABLE LOSS (dB)	PREAMP FACTOR (dB)	ANTENNA HEIGHT (cm)	TABLE ANGLE (Degree)	REMARK
5026	39.18	39.95	54	-14.82	31.23	5.24	37.24	100	186	Average
5026	60.29	61.06	74	-13.71	31.23	5.24	37.24	100	186	Peak
5300	102.97	103.35			31.44	5.37	37.19	100	186	Average
5300	111.7	112.08			31.44	5.37	37.19	100	186	Peak
5352	45.22	45.53	54	-8.78	31.48	5.39	37.18	100	186	Average
5352	64.22	64.53	74	-9.78	31.48	5.39	37.18	100	186	Peak
10600	41.11	45.67	54	-12.89	39.57	8.28	52.41	100	108	Average
10600	49.02	53.58	74	-24.98	39.57	8.28	52.41	100	108	Peak

REMARKS:

- Emission Level = Read Level + Antenna Factor + Cable Loss - Preamp Factor
Margin value = Emission level – Limit value
- 5300MHz: Fundamental frequency.



A D T

EUT TEST CONDITION		MEASUREMENT DETAIL	
CHANNEL	Channel 64	FREQUENCY RANGE	1GHz ~ 40GHz
INPUT POWER	120Vac, 60 Hz	DETECTOR FUNCTION	Peak (PK) Average (AV)
ENVIRONMENTAL CONDITIONS	25deg. C, 65%RH	TESTED BY	Toby Tian

ANTENNA POLARITY & TEST DISTANCE: HORIZONTAL AT 3 M										
FREQ. (MHz)	EMISSION LEVEL (dBuV/m)	READ LEVEL (dBuV)	LIMIT (dBuV/m)	MARGIN (dB)	ANTENNA FACTOR (dB/m)	CABLE LOSS (dB)	PREAMP FACTOR (dB)	ANTENNA HEIGHT (cm)	TABLE ANGLE (Degree)	REMARK
5106	37.96	38.68	54	-16.04	31.29	5.27	37.28	103	202	Average
5106	60.52	61.24	74	-13.48	31.29	5.27	37.28	103	202	Peak
5320	97.26	97.62			31.45	5.38	37.19	103	202	Average
5320	106.97	107.33			31.45	5.38	37.19	103	202	Peak
5350	48.23	48.54	54	-5.77	31.48	5.39	37.18	103	202	Average
5350	68.5	68.81	74	-5.5	31.48	5.39	37.18	103	202	Peak
10640	42	46.33	54	-12	39.62	8.32	52.27	100	172	Average
10640	51.01	55.34	74	-22.99	39.62	8.32	52.27	100	172	Peak
ANTENNA POLARITY & TEST DISTANCE: VERTICAL AT 3 M										
FREQ. (MHz)	EMISSION LEVEL (dBuV/m)	READ LEVEL (dBuV)	LIMIT (dBuV/m)	MARGIN (dB)	ANTENNA FACTOR (dB/m)	CABLE LOSS (dB)	PREAMP FACTOR (dB)	ANTENNA HEIGHT (cm)	TABLE ANGLE (Degree)	REMARK
5006	38.1	38.9	54	-15.9	31.21	5.22	37.23	100	186	Average
5006	59.96	60.76	74	-14.04	31.21	5.22	37.23	100	186	Peak
5320	102.32	102.68			31.45	5.38	37.19	100	186	Average
5320	110.99	111.35			31.45	5.38	37.19	100	186	Peak
5350	52.49	52.8	54	-1.51	31.48	5.39	37.18	100	186	Average
5350	70.24	70.55	74	-3.76	31.48	5.39	37.18	100	186	Peak
10640	41.89	46.22	54	-12.11	39.62	8.32	52.27	100	108	Average
10640	50.04	54.37	74	-23.96	39.62	8.32	52.27	100	108	Peak

REMARKS:

- Emission Level = Read Level + Antenna Factor + Cable Loss - Preamp Factor
Margin value = Emission level – Limit value
- 5320MHz: Fundamental frequency.



A D T

EUT TEST CONDITION		MEASUREMENT DETAIL	
CHANNEL	Channel 100	FREQUENCY RANGE	1GHz ~ 40GHz
INPUT POWER	120Vac, 60 Hz	DETECTOR FUNCTION	Peak (PK) Average (AV)
ENVIRONMENTAL CONDITIONS	25deg. C, 65%RH	TESTED BY	Toby Tian

ANTENNA POLARITY & TEST DISTANCE: HORIZONTAL AT 3 M

FREQ. (MHz)	EMISSION LEVEL (dBuV/m)	READ LEVEL (dBuV)	LIMIT (dBuV/m)	MARGIN (dB)	ANTENNA FACTOR (dB/m)	CABLE LOSS (dB)	PREAMP FACTOR (dB)	ANTENNA HEIGHT (cm)	TABLE ANGLE (Degree)	REMARK
5432	41.17	41.33	54	-12.83	31.55	5.42	37.13	100	193	Average
5432	60.58	60.74	74	-13.42	31.55	5.42	37.13	100	193	Peak
5470	62.85	62.91	68.2	-5.35	31.57	5.45	37.08	100	193	Peak
5500	93.63	93.6			31.6	5.46	37.03	100	193	Average
5500	103.41	103.38			31.6	5.46	37.03	100	193	Peak
5725	59.5	59.38	68.2	-8.7	31.96	5.59	37.43	100	193	Peak
11000	40.29	44.98	54	-13.71	40.2	8.56	53.45	100	86	Average
11000	47.87	52.56	74	-26.13	40.2	8.56	53.45	100	86	Peak

ANTENNA POLARITY & TEST DISTANCE: VERTICAL AT 3 M

FREQ. (MHz)	EMISSION LEVEL (dBuV/m)	READ LEVEL (dBuV)	LIMIT (dBuV/m)	MARGIN (dB)	ANTENNA FACTOR (dB/m)	CABLE LOSS (dB)	PREAMP FACTOR (dB)	ANTENNA HEIGHT (cm)	TABLE ANGLE (Degree)	REMARK
5460	42.14	42.22	54	-11.86	31.56	5.44	37.08	102	114	Average
5460	60.48	60.56	74	-13.52	31.56	5.44	37.08	102	114	Peak
5470	64.79	64.85	68.2	-3.41	31.57	5.45	37.08	102	114	Peak
5500	96.19	96.16			31.6	5.46	37.03	102	114	Average
5500	105.61	105.58			31.6	5.46	37.03	102	114	Peak
5725	58.41	58.29	68.2	-9.79	31.96	5.59	37.43	102	114	Peak
11000	39.81	44.5	54	-14.19	40.2	8.56	53.45	100	228	Average
11000	49.36	54.05	74	-24.64	40.2	8.56	53.45	100	228	Peak

REMARKS:

- Emission Level = Read Level + Antenna Factor + Cable Loss - Preamp Factor
Margin value = Emission level – Limit value
- 5500MHz: Fundamental frequency.
- 5470MHz & 5725MHz: Out of restricted band



A D T

EUT TEST CONDITION		MEASUREMENT DETAIL	
CHANNEL	Channel 116	FREQUENCY RANGE	1GHz ~ 40GHz
INPUT POWER	120Vac, 60 Hz	DETECTOR FUNCTION	Peak (PK) Average (AV)
ENVIRONMENTAL CONDITIONS	25deg. C, 65%RH	TESTED BY	Toby Tian

ANTENNA POLARITY & TEST DISTANCE: HORIZONTAL AT 3 M

FREQ. (MHz)	EMISSION LEVEL (dBuV/m)	READ LEVEL (dBuV)	LIMIT (dBuV/m)	MARGIN (dB)	ANTENNA FACTOR (dB/m)	CABLE LOSS (dB)	PREAMP FACTOR (dB)	ANTENNA HEIGHT (cm)	TABLE ANGLE (Degree)	REMARK
5366	38.11	38.4	54	-15.89	31.49	5.4	37.18	133	156	Average
5366	59.88	60.17	74	-14.12	31.49	5.4	37.18	133	156	Peak
5470	58.49	58.55	68.2	-9.71	31.57	5.45	37.08	133	156	Peak
5580	95.57	95.52			31.71	5.5	37.16	133	156	Average
5580	104.85	104.8			31.71	5.5	37.16	133	156	Peak
5725	59.73	59.61	68.2	-8.47	31.96	5.59	37.43	133	156	Peak
11160	41.36	45.94	54	-12.64	40.1	8.71	53.39	100	86	Average
11160	52.07	56.65	74	-21.93	40.1	8.71	53.39	100	86	Peak

ANTENNA POLARITY & TEST DISTANCE: VERTICAL AT 3 M

FREQ. (MHz)	EMISSION LEVEL (dBuV/m)	READ LEVEL (dBuV)	LIMIT (dBuV/m)	MARGIN (dB)	ANTENNA FACTOR (dB/m)	CABLE LOSS (dB)	PREAMP FACTOR (dB)	ANTENNA HEIGHT (cm)	TABLE ANGLE (Degree)	REMARK
5452	38.67	38.75	54	-15.33	31.56	5.44	37.08	100	117	Average
5452	60.2	60.28	74	-13.8	31.56	5.44	37.08	100	117	Peak
5470	58.57	58.63	68.2	-9.63	31.57	5.45	37.08	100	117	Peak
5580	100.07	100.02			31.71	5.5	37.16	100	117	Average
5580	110.14	110.09			31.71	5.5	37.16	100	117	Peak
5725	60.95	60.83	68.2	-7.25	31.96	5.59	37.43	100	117	Peak
11160	41.2	45.78	54	-12.8	40.1	8.71	53.39	100	228	Average
11160	52.36	56.94	74	-21.64	40.1	8.71	53.39	100	228	Peak

REMARKS:

- Emission Level = Read Level + Antenna Factor + Cable Loss - Preamp Factor
Margin value = Emission level – Limit value
- 5580MHz: Fundamental frequency.
- 5470MHz & 5725MHz: Out of restricted band



A D T

EUT TEST CONDITION		MEASUREMENT DETAIL	
CHANNEL	Channel 120	FREQUENCY RANGE	1GHz ~ 40GHz
INPUT POWER	120Vac, 60 Hz	DETECTOR FUNCTION	Peak (PK) Average (AV)
ENVIRONMENTAL CONDITIONS	25deg. C, 65%RH	TESTED BY	Toby Tian

ANTENNA POLARITY & TEST DISTANCE: HORIZONTAL AT 3 M										
FREQ. (MHz)	EMISSION LEVEL (dBuV/m)	READ LEVEL (dBuV)	LIMIT (dBuV/m)	MARGIN (dB)	ANTENNA FACTOR (dB/m)	CABLE LOSS (dB)	PREAMP FACTOR (dB)	ANTENNA HEIGHT (cm)	TABLE ANGLE (Degree)	REMARK
5410	39	39.25	54	-15	31.52	5.41	37.18	100	190	Average
5410	59.54	59.79	74	-14.46	31.52	5.41	37.18	100	190	Peak
5470	58.38	58.44	68.2	-9.82	31.57	5.45	37.08	100	190	Peak
5600	98.7	98.57			31.77	5.52	37.16	100	190	Average
5600	108.47	108.34			31.77	5.52	37.16	100	190	Peak
5725	57.91	57.79	68.2	-10.29	31.96	5.59	37.43	100	190	Peak
11200	41.75	46.07	54	-12.25	40.08	8.76	53.16	100	87	Average
11200	52.23	56.55	74	-21.77	40.08	8.76	53.16	100	87	Peak
ANTENNA POLARITY & TEST DISTANCE: VERTICAL AT 3 M										
FREQ. (MHz)	EMISSION LEVEL (dBuV/m)	READ LEVEL (dBuV)	LIMIT (dBuV/m)	MARGIN (dB)	ANTENNA FACTOR (dB/m)	CABLE LOSS (dB)	PREAMP FACTOR (dB)	ANTENNA HEIGHT (cm)	TABLE ANGLE (Degree)	REMARK
5430	39.06	39.22	54	-14.94	31.55	5.42	37.13	101	124	Average
5430	60.5	60.66	74	-13.5	31.55	5.42	37.13	101	124	Peak
5470	58.53	58.59	68.2	-9.67	31.57	5.45	37.08	101	124	Peak
5600	101.9	101.77			31.77	5.52	37.16	101	124	Average
5600	111.21	111.08			31.77	5.52	37.16	101	124	Peak
5725	59.02	58.9	68.2	-9.18	31.96	5.59	37.43	101	124	Peak
11200	41.78	46.1	54	-12.22	40.08	8.76	53.16	100	228	Average
11200	51.85	56.17	74	-22.15	40.08	8.76	53.16	100	228	Peak

REMARKS:

- Emission Level = Read Level + Antenna Factor + Cable Loss - Preamp Factor
Margin value = Emission level – Limit value
- 5600MHz: Fundamental frequency.
- 5470MHz & 5725MHz: Out of restricted band



A D T

EUT TEST CONDITION		MEASUREMENT DETAIL	
CHANNEL	Channel 140	FREQUENCY RANGE	1GHz ~ 40GHz
INPUT POWER	120Vac, 60 Hz	DETECTOR FUNCTION	Peak (PK) Average (AV)
ENVIRONMENTAL CONDITIONS	25deg. C, 65%RH	TESTED BY	Toby Tian

ANTENNA POLARITY & TEST DISTANCE: HORIZONTAL AT 3 M										
FREQ. (MHz)	EMISSION LEVEL (dBuV/m)	READ LEVEL (dBuV)	LIMIT (dBuV/m)	MARGIN (dB)	ANTENNA FACTOR (dB/m)	CABLE LOSS (dB)	PREAMP FACTOR (dB)	ANTENNA HEIGHT (cm)	TABLE ANGLE (Degree)	REMARK
5416	37.85	38.08	54	-16.15	31.53	5.42	37.18	100	175	Average
5416	59.54	59.77	74	-14.46	31.53	5.42	37.18	100	175	Peak
5470	57.32	57.38	68.2	-10.88	31.57	5.45	37.08	100	175	Peak
5700	95.08	95.01			31.9	5.57	37.4	100	175	Average
5700	104.82	104.75			31.9	5.57	37.4	100	175	Peak
5725	63.95	63.83	68.2	-4.25	31.96	5.59	37.43	100	175	Peak
11400	42.41	45.63	54	-11.59	39.96	8.95	52.13	100	86	Average
11400	52.61	55.83	74	-21.39	39.96	8.95	52.13	100	86	Peak
ANTENNA POLARITY & TEST DISTANCE: VERTICAL AT 3 M										
FREQ. (MHz)	EMISSION LEVEL (dBuV/m)	READ LEVEL (dBuV)	LIMIT (dBuV/m)	MARGIN (dB)	ANTENNA FACTOR (dB/m)	CABLE LOSS (dB)	PREAMP FACTOR (dB)	ANTENNA HEIGHT (cm)	TABLE ANGLE (Degree)	REMARK
5364	37.83	38.12	54	-16.17	31.49	5.4	37.18	111	136	Average
5364	59.71	60	74	-14.29	31.49	5.4	37.18	111	136	Peak
5470	58.02	58.08	68.2	-10.18	31.57	5.45	37.08	111	136	Peak
5700	99.38	99.31			31.9	5.57	37.4	111	136	Average
5700	108.76	108.69			31.9	5.57	37.4	111	136	Peak
5725	66.58	66.46	68.2	-1.62	31.96	5.59	37.43	111	136	Peak
11400	42.05	45.27	54	-11.95	39.96	8.95	52.13	100	228	Average
11400	52.75	55.97	74	-21.25	39.96	8.95	52.13	100	228	Peak

REMARKS:

- Emission Level = Read Level + Antenna Factor + Cable Loss - Preamp Factor
Margin value = Emission level – Limit value
- 5700MHz: Fundamental frequency.
- 5470MHz & 5725MHz: Out of restricted band



A D T

EUT TEST CONDITION		MEASUREMENT DETAIL	
CHANNEL	Channel 149	FREQUENCY RANGE	1GHz ~ 40GHz
INPUT POWER	120Vac, 60 Hz	DETECTOR FUNCTION	Peak (PK) Average (AV)
ENVIRONMENTAL CONDITIONS	25deg. C, 65%RH	TESTED BY	Toby Tian

ANTENNA POLARITY & TEST DISTANCE: HORIZONTAL AT 3 M

FREQ. (MHz)	EMISSION LEVEL (dBuV/m)	READ LEVEL (dBuV)	LIMIT (dBuV/m)	MARGIN (dB)	ANTENNA FACTOR (dB/m)	CABLE LOSS (dB)	PREAMP FACTOR (dB)	ANTENNA HEIGHT (cm)	TABLE ANGLE (Degree)	REMARK
5714	61.22	61.13	68.2	-6.98	31.93	5.59	37.43	116	172	Peak
5725	71.72	71.6	78.2	-6.48	31.96	5.59	37.43	116	172	Peak
5745	99.16	99.04			31.99	5.6	37.47	116	172	Average
5745	108.69	108.57			31.99	5.6	37.47	116	172	Peak
5850	58.35	58.05	78.2	-19.85	32.15	5.66	37.51	116	172	Peak
5861	59.12	58.78	68.2	-9.08	32.18	5.66	37.5	116	172	Peak
11490	42.35	46.22	54	-11.65	39.91	9.05	52.83	100	306	Average
11490	53.39	57.26	74	-20.61	39.91	9.05	52.83	100	306	Peak

ANTENNA POLARITY & TEST DISTANCE: VERTICAL AT 3 M

FREQ. (MHz)	EMISSION LEVEL (dBuV/m)	READ LEVEL (dBuV)	LIMIT (dBuV/m)	MARGIN (dB)	ANTENNA FACTOR (dB/m)	CABLE LOSS (dB)	PREAMP FACTOR (dB)	ANTENNA HEIGHT (cm)	TABLE ANGLE (Degree)	REMARK
5714	64.93	64.84	68.2	-3.27	31.93	5.59	37.43	101	146	Peak
5725	71.11	70.99	78.2	-7.09	31.96	5.59	37.43	101	146	Peak
5745	100.7	100.58			31.99	5.6	37.47	101	146	Average
5745	110.04	109.92			31.99	5.6	37.47	101	146	Peak
5850	59.51	59.21	78.2	-18.69	32.15	5.66	37.51	101	146	Peak
5861	59.78	59.44	68.2	-8.42	32.18	5.66	37.5	101	146	Peak
11490	42.45	46.32	54	-11.55	39.91	9.05	52.83	100	80	Average
11490	52.67	56.54	74	-21.33	39.91	9.05	52.83	100	80	Peak

REMARKS:

- Emission Level = Read Level + Antenna Factor + Cable Loss - Preamp Factor
Margin value = Emission level – Limit value
- 5745MHz: Fundamental frequency.
- 5714, 5725MHz, 5850 & 5861MHz: Out of restricted band



A D T

EUT TEST CONDITION		MEASUREMENT DETAIL	
CHANNEL	Channel 157	FREQUENCY RANGE	1GHz ~ 40GHz
INPUT POWER	120Vac, 60 Hz	DETECTOR FUNCTION	Peak (PK) Average (AV)
ENVIRONMENTAL CONDITIONS	25deg. C, 65%RH	TESTED BY	Toby Tian

ANTENNA POLARITY & TEST DISTANCE: HORIZONTAL AT 3 M

FREQ. (MHz)	EMISSION LEVEL (dBuV/m)	READ LEVEL (dBuV)	LIMIT (dBuV/m)	MARGIN (dB)	ANTENNA FACTOR (dB/m)	CABLE LOSS (dB)	PREAMP FACTOR (dB)	ANTENNA HEIGHT (cm)	TABLE ANGLE (Degree)	REMARK
5714	59.09	59	68.2	-9.11	31.93	5.59	37.43	115	176	Peak
5725	60.03	59.91	78.2	-18.17	31.96	5.59	37.43	115	176	Peak
5785	101.28	101.16			32.04	5.62	37.54	115	176	Average
5785	110.78	110.66			32.04	5.62	37.54	115	176	Peak
5850	61.4	61.1	78.2	-16.8	32.15	5.66	37.51	115	176	Peak
5861	60.27	59.93	68.2	-7.93	32.18	5.66	37.5	115	176	Peak
11570	41.57	46.03	54	-12.43	39.78	9.09	53.33	100	335	Average
11570	51.93	56.39	74	-22.07	39.78	9.09	53.33	100	335	Peak

ANTENNA POLARITY & TEST DISTANCE: VERTICAL AT 3 M

FREQ. (MHz)	EMISSION LEVEL (dBuV/m)	READ LEVEL (dBuV)	LIMIT (dBuV/m)	MARGIN (dB)	ANTENNA FACTOR (dB/m)	CABLE LOSS (dB)	PREAMP FACTOR (dB)	ANTENNA HEIGHT (cm)	TABLE ANGLE (Degree)	REMARK
5714	60.51	60.42	68.2	-7.69	31.93	5.59	37.43	100	143	Peak
5725	60.43	60.31	78.2	-17.77	31.96	5.59	37.43	100	143	Peak
5785	102.95	102.83			32.04	5.62	37.54	100	143	Average
5785	112.13	112.01			32.04	5.62	37.54	100	143	Peak
5850	59.97	59.67	78.2	-18.23	32.15	5.66	37.51	100	143	Peak
5861	59.67	59.33	68.2	-8.53	32.18	5.66	37.5	100	143	Peak
11570	41.65	46.11	54	-12.35	39.78	9.09	53.33	100	52	Average
11570	52.9	57.36	74	-21.1	39.78	9.09	53.33	100	52	Peak

REMARKS:

- Emission Level = Read Level + Antenna Factor + Cable Loss - Preamp Factor
Margin value = Emission level – Limit value
- 5785MHz: Fundamental frequency.
- 5714, 5725MHz, 5850 & 5861MHz: Out of restricted band



A D T

EUT TEST CONDITION		MEASUREMENT DETAIL	
CHANNEL	Channel 165	FREQUENCY RANGE	1GHz ~ 40GHz
INPUT POWER	120Vac, 60 Hz	DETECTOR FUNCTION	Peak (PK) Average (AV)
ENVIRONMENTAL CONDITIONS	25deg. C, 65%RH	TESTED BY	Toby Tian

ANTENNA POLARITY & TEST DISTANCE: HORIZONTAL AT 3 M

FREQ. (MHz)	EMISSION LEVEL (dBuV/m)	READ LEVEL (dBuV)	LIMIT (dBuV/m)	MARGIN (dB)	ANTENNA FACTOR (dB/m)	CABLE LOSS (dB)	PREAMP FACTOR (dB)	ANTENNA HEIGHT (cm)	TABLE ANGLE (Degree)	REMARK
5714	57.84	57.75	68.2	-10.36	31.93	5.59	37.43	114	174	Peak
5725	60.28	60.16	78.2	-17.92	31.96	5.59	37.43	114	174	Peak
5825	102.73	102.5			32.12	5.64	37.53	114	174	Average
5825	111.58	111.35			32.12	5.64	37.53	114	174	Peak
5850	74.58	74.28	78.2	-3.62	32.15	5.66	37.51	114	174	Peak
5861	66.66	66.32	68.2	-1.54	32.18	5.66	37.5	114	174	Peak
11650	41.83	46.41	54	-12.17	39.65	9.12	53.35	100	295	Average
11650	53.27	57.85	74	-20.73	39.65	9.12	53.35	100	295	Peak

ANTENNA POLARITY & TEST DISTANCE: VERTICAL AT 3 M

FREQ. (MHz)	EMISSION LEVEL (dBuV/m)	READ LEVEL (dBuV)	LIMIT (dBuV/m)	MARGIN (dB)	ANTENNA FACTOR (dB/m)	CABLE LOSS (dB)	PREAMP FACTOR (dB)	ANTENNA HEIGHT (cm)	TABLE ANGLE (Degree)	REMARK
5714	59.38	59.29	68.2	-8.82	31.93	5.59	37.43	100	142	Peak
5725	60.44	60.32	78.2	-17.76	31.96	5.59	37.43	100	142	Peak
5825	103.24	103.01			32.12	5.64	37.53	100	142	Average
5825	112.33	112.1			32.12	5.64	37.53	100	142	Peak
5850	73.64	73.34	78.2	-4.56	32.15	5.66	37.51	100	142	Peak
5861	66.71	66.37	68.2	-1.49	32.18	5.66	37.5	100	142	Peak
11650	41.87	46.45	54	-12.13	39.65	9.12	53.35	100	79	Average
11650	51.68	56.26	74	-22.32	39.65	9.12	53.35	100	79	Peak

REMARKS:

- Emission Level = Read Level + Antenna Factor + Cable Loss - Preamp Factor
Margin value = Emission level – Limit value
- 5825MHz: Fundamental frequency.
- 5714, 5725MHz, 5850 & 5861MHz: Out of restricted band



A D T

802.11n (20MHz)

EUT TEST CONDITION		MEASUREMENT DETAIL	
CHANNEL	Channel 36	FREQUENCY RANGE	1GHz ~ 40GHz
INPUT POWER	120Vac, 60 Hz	DETECTOR FUNCTION	Peak (PK) Average (AV)
ENVIRONMENTAL CONDITIONS	25deg. C, 65%RH	TESTED BY	Toby Tian

ANTENNA POLARITY & TEST DISTANCE: HORIZONTAL AT 3 M

FREQ. (MHz)	EMISSION LEVEL (dBuV/m)	READ LEVEL (dBuV)	LIMIT (dBuV/m)	MARGIN (dB)	ANTENNA FACTOR (dB/m)	CABLE LOSS (dB)	PREAMP FACTOR (dB)	ANTENNA HEIGHT (cm)	TABLE ANGLE (Degree)	REMARK
5150	48.96	49.67	54	-5.04	31.32	5.29	37.32	106	199	Average
5150	66.38	67.09	74	-7.62	31.32	5.29	37.32	106	199	Peak
5180	99.36	100.04			31.35	5.31	37.34	106	199	Average
5180	108.26	108.94			31.35	5.31	37.34	106	199	Peak
5398	38.75	39	54	-15.25	31.52	5.41	37.18	106	199	Average
5398	60.13	60.38	74	-13.87	31.52	5.41	37.18	106	199	Peak
10360	49.74	54.56	68.2	-18.46	39.19	8.13	52.14	100	290	Peak

ANTENNA POLARITY & TEST DISTANCE: VERTICAL AT 3 M

FREQ. (MHz)	EMISSION LEVEL (dBuV/m)	READ LEVEL (dBuV)	LIMIT (dBuV/m)	MARGIN (dB)	ANTENNA FACTOR (dB/m)	CABLE LOSS (dB)	PREAMP FACTOR (dB)	ANTENNA HEIGHT (cm)	TABLE ANGLE (Degree)	REMARK
5150	52.88	53.59	54	-1.12	31.32	5.29	37.32	101	156	Average
5150	70.45	71.16	74	-3.55	31.32	5.29	37.32	101	156	Peak
5180	102.85	103.53			31.35	5.31	37.34	101	156	Average
5180	110.8	111.48			31.35	5.31	37.34	101	156	Peak
5392	38.96	39.22	54	-15.04	31.51	5.41	37.18	101	156	Average
5392	60.49	60.75	74	-13.51	31.51	5.41	37.18	101	156	Peak
10360	50.29	55.11	68.2	-17.91	39.19	8.13	52.14	100	94	Peak

REMARKS:

- Emission Level = Read Level + Antenna Factor + Cable Loss - Preamp Factor
Margin value = Emission level – Limit value
- 5180MHz: Fundamental frequency.
- 10360MHz: Out of restricted band



A D T

EUT TEST CONDITION		MEASUREMENT DETAIL	
CHANNEL	Channel 44	FREQUENCY RANGE	1GHz ~ 40GHz
INPUT POWER	120Vac, 60 Hz	DETECTOR FUNCTION	Peak (PK) Average (AV)
ENVIRONMENTAL CONDITIONS	25deg. C, 65%RH	TESTED BY	Toby Tian

ANTENNA POLARITY & TEST DISTANCE: HORIZONTAL AT 3 M										
FREQ. (MHz)	EMISSION LEVEL (dBuV/m)	READ LEVEL (dBuV)	LIMIT (dBuV/m)	MARGIN (dB)	ANTENNA FACTOR (dB/m)	CABLE LOSS (dB)	PREAMP FACTOR (dB)	ANTENNA HEIGHT (cm)	TABLE ANGLE (Degree)	REMARK
5078	40.22	40.96	54	-13.78	31.27	5.26	37.27	106	201	Average
5078	60.14	60.88	74	-13.86	31.27	5.26	37.27	106	201	Peak
5220	100.49	101.15			31.37	5.33	37.36	106	201	Average
5220	109.32	109.98			31.37	5.33	37.36	106	201	Peak
5422	38.71	38.94	54	-15.29	31.53	5.42	37.18	106	201	Average
5422	60.62	60.85	74	-13.38	31.53	5.42	37.18	106	201	Peak
10438	50.5	55.5	68.2	-17.7	39.29	8.19	52.48	100	324	Peak
ANTENNA POLARITY & TEST DISTANCE: VERTICAL AT 3 M										
FREQ. (MHz)	EMISSION LEVEL (dBuV/m)	READ LEVEL (dBuV)	LIMIT (dBuV/m)	MARGIN (dB)	ANTENNA FACTOR (dB/m)	CABLE LOSS (dB)	PREAMP FACTOR (dB)	ANTENNA HEIGHT (cm)	TABLE ANGLE (Degree)	REMARK
5072	41.86	42.6	54	-12.14	31.27	5.26	37.27	100	160	Average
5072	60.54	61.28	74	-13.46	31.27	5.26	37.27	100	160	Peak
5220	104.15	104.81			31.37	5.33	37.36	100	160	Average
5220	112.41	113.07			31.37	5.33	37.36	100	160	Peak
5376	39.7	39.99	54	-14.3	31.49	5.4	37.18	100	160	Average
5376	60.46	60.75	74	-13.54	31.49	5.4	37.18	100	160	Peak
10440	51.12	56.12	68.2	-17.08	39.29	8.19	52.48	100	141	Peak

REMARKS:

- Emission Level = Read Level + Antenna Factor + Cable Loss - Preamp Factor
Margin value = Emission level – Limit value
- 5220MHz: Fundamental frequency.
- 10438MHz & 10440MHz: Out of restricted band



A D T

EUT TEST CONDITION		MEASUREMENT DETAIL	
CHANNEL	Channel 48	FREQUENCY RANGE	1GHz ~ 40GHz
INPUT POWER	120Vac, 60 Hz	DETECTOR FUNCTION	Peak (PK) Average (AV)
ENVIRONMENTAL CONDITIONS	25deg. C, 65%RH	TESTED BY	Toby Tian

ANTENNA POLARITY & TEST DISTANCE: HORIZONTAL AT 3 M										
FREQ. (MHz)	EMISSION LEVEL (dBuV/m)	READ LEVEL (dBuV)	LIMIT (dBuV/m)	MARGIN (dB)	ANTENNA FACTOR (dB/m)	CABLE LOSS (dB)	PREAMP FACTOR (dB)	ANTENNA HEIGHT (cm)	TABLE ANGLE (Degree)	REMARK
5126	39.48	40.19	54	-14.52	31.31	5.28	37.3	104	200	Average
5126	60.11	60.82	74	-13.89	31.31	5.28	37.3	104	200	Peak
5240	100.3	100.89			31.39	5.34	37.32	104	200	Average
5240	109.11	109.7			31.39	5.34	37.32	104	200	Peak
5460	38.97	39.05	54	-15.03	31.56	5.44	37.08	104	200	Average
5460	60.44	60.52	74	-13.56	31.56	5.44	37.08	104	200	Peak
10480	52.26	57.4	68.2	-15.94	39.37	8.2	52.71	100	269	Peak
ANTENNA POLARITY & TEST DISTANCE: VERTICAL AT 3 M										
FREQ. (MHz)	EMISSION LEVEL (dBuV/m)	READ LEVEL (dBuV)	LIMIT (dBuV/m)	MARGIN (dB)	ANTENNA FACTOR (dB/m)	CABLE LOSS (dB)	PREAMP FACTOR (dB)	ANTENNA HEIGHT (cm)	TABLE ANGLE (Degree)	REMARK
5068	41.06	41.82	54	-12.94	31.25	5.26	37.27	100	162	Average
5068	59.74	60.5	74	-14.26	31.25	5.26	37.27	100	162	Peak
5240	104.05	104.64			31.39	5.34	37.32	100	162	Average
5240	111.94	112.53			31.39	5.34	37.32	100	162	Peak
5430	39.89	40.05	54	-14.11	31.55	5.42	37.13	100	162	Average
5430	61.07	61.23	74	-12.93	31.55	5.42	37.13	100	162	Peak
10480	52.78	57.92	68.2	-15.42	39.37	8.2	52.71	100	50	Peak

REMARKS:

- Emission Level = Read Level + Antenna Factor + Cable Loss - Preamp Factor
Margin value = Emission level – Limit value
- 5240MHz: Fundamental frequency.
- 10480MHz: Out of restricted band



A D T

EUT TEST CONDITION		MEASUREMENT DETAIL	
CHANNEL	Channel 52	FREQUENCY RANGE	1GHz ~ 40GHz
INPUT POWER	120Vac, 60 Hz	DETECTOR FUNCTION	Peak (PK) Average (AV)
ENVIRONMENTAL CONDITIONS	25deg. C, 65%RH	TESTED BY	Toby Tian

ANTENNA POLARITY & TEST DISTANCE: HORIZONTAL AT 3 M										
FREQ. (MHz)	EMISSION LEVEL (dBuV/m)	READ LEVEL (dBuV)	LIMIT (dBuV/m)	MARGIN (dB)	ANTENNA FACTOR (dB/m)	CABLE LOSS (dB)	PREAMP FACTOR (dB)	ANTENNA HEIGHT (cm)	TABLE ANGLE (Degree)	REMARK
5042	38.14	38.9	54	-15.86	31.24	5.25	37.25	105	204	Average
5042	59.89	60.65	74	-14.11	31.24	5.25	37.25	105	204	Peak
5260	97.54	98.06			31.41	5.34	37.27	105	204	Average
5260	107.31	107.83			31.41	5.34	37.27	105	204	Peak
5370	38.22	38.51	54	-15.78	31.49	5.4	37.18	105	204	Average
5370	59.96	60.25	74	-14.04	31.49	5.4	37.18	105	204	Peak
10520	48.64	53.81	68.2	-19.56	39.43	8.23	52.83	100	172	Peak
ANTENNA POLARITY & TEST DISTANCE: VERTICAL AT 3 M										
FREQ. (MHz)	EMISSION LEVEL (dBuV/m)	READ LEVEL (dBuV)	LIMIT (dBuV/m)	MARGIN (dB)	ANTENNA FACTOR (dB/m)	CABLE LOSS (dB)	PREAMP FACTOR (dB)	ANTENNA HEIGHT (cm)	TABLE ANGLE (Degree)	REMARK
5094	38.21	38.94	54	-15.79	31.28	5.27	37.28	100	187	Average
5094	59.76	60.49	74	-14.24	31.28	5.27	37.28	100	187	Peak
5260	102.33	102.85			31.41	5.34	37.27	100	187	Average
5260	111.28	111.8			31.41	5.34	37.27	100	187	Peak
5374	39.16	39.45	54	-14.84	31.49	5.4	37.18	100	187	Average
5374	60.03	60.32	74	-13.97	31.49	5.4	37.18	100	187	Peak
10520	49.65	54.82	68.2	-18.55	39.43	8.23	52.83	100	108	Peak

REMARKS:

- Emission Level = Read Level + Antenna Factor + Cable Loss - Preamp Factor
Margin value = Emission level – Limit value
- 5260MHz: Fundamental frequency.
- 10520MHz: Out of restricted band



A D T

EUT TEST CONDITION		MEASUREMENT DETAIL	
CHANNEL	Channel 60	FREQUENCY RANGE	1GHz ~ 40GHz
INPUT POWER	120Vac, 60 Hz	DETECTOR FUNCTION	Peak (PK) Average (AV)
ENVIRONMENTAL CONDITIONS	25deg. C, 65%RH	TESTED BY	Toby Tian

ANTENNA POLARITY & TEST DISTANCE: HORIZONTAL AT 3 M										
FREQ. (MHz)	EMISSION LEVEL (dBuV/m)	READ LEVEL (dBuV)	LIMIT (dBuV/m)	MARGIN (dB)	ANTENNA FACTOR (dB/m)	CABLE LOSS (dB)	PREAMP FACTOR (dB)	ANTENNA HEIGHT (cm)	TABLE ANGLE (Degree)	REMARK
5126	37.75	38.46	54	-16.25	31.31	5.28	37.3	104	201	Average
5126	60.32	61.03	74	-13.68	31.31	5.28	37.3	104	201	Peak
5300	97.25	97.63			31.44	5.37	37.19	104	201	Average
5300	107.36	107.74			31.44	5.37	37.19	104	201	Peak
5350	40.6	40.91	54	-13.4	31.48	5.39	37.18	104	201	Average
5350	61.97	62.28	74	-12.03	31.48	5.39	37.18	104	201	Peak
10600	41.25	45.81	54	-12.75	39.57	8.28	52.41	100	172	Average
10600	49.04	53.6	74	-24.96	39.57	8.28	52.41	100	172	Peak
ANTENNA POLARITY & TEST DISTANCE: VERTICAL AT 3 M										
FREQ. (MHz)	EMISSION LEVEL (dBuV/m)	READ LEVEL (dBuV)	LIMIT (dBuV/m)	MARGIN (dB)	ANTENNA FACTOR (dB/m)	CABLE LOSS (dB)	PREAMP FACTOR (dB)	ANTENNA HEIGHT (cm)	TABLE ANGLE (Degree)	REMARK
5066	38.16	38.9	54	-15.84	31.25	5.26	37.25	100	188	Average
5066	59.66	60.4	74	-14.34	31.25	5.26	37.25	100	188	Peak
5300	102.02	102.4			31.44	5.37	37.19	100	188	Average
5300	111.48	111.86			31.44	5.37	37.19	100	188	Peak
5350	43.23	43.54	54	-10.77	31.48	5.39	37.18	100	188	Average
5350	61.94	62.25	74	-12.06	31.48	5.39	37.18	100	188	Peak
10600	41.19	45.75	54	-12.81	39.57	8.28	52.41	100	108	Average
10600	49.07	53.63	74	-24.93	39.57	8.28	52.41	100	108	Peak

REMARKS:

- Emission Level = Read Level + Antenna Factor + Cable Loss - Preamp Factor
Margin value = Emission level – Limit value
- 5300MHz: Fundamental frequency.



A D T

EUT TEST CONDITION		MEASUREMENT DETAIL	
CHANNEL	Channel 64	FREQUENCY RANGE	1GHz ~ 40GHz
INPUT POWER	120Vac, 60 Hz	DETECTOR FUNCTION	Peak (PK) Average (AV)
ENVIRONMENTAL CONDITIONS	25deg. C, 65%RH	TESTED BY	Toby Tian

ANTENNA POLARITY & TEST DISTANCE: HORIZONTAL AT 3 M										
FREQ. (MHz)	EMISSION LEVEL (dBuV/m)	READ LEVEL (dBuV)	LIMIT (dBuV/m)	MARGIN (dB)	ANTENNA FACTOR (dB/m)	CABLE LOSS (dB)	PREAMP FACTOR (dB)	ANTENNA HEIGHT (cm)	TABLE ANGLE (Degree)	REMARK
5134	37.99	38.7	54	-16.01	31.31	5.28	37.3	104	201	Average
5134	60.48	61.19	74	-13.52	31.31	5.28	37.3	104	201	Peak
5320	96.36	96.72			31.45	5.38	37.19	104	201	Average
5320	105.73	106.09			31.45	5.38	37.19	104	201	Peak
5350	47.76	48.07	54	-6.24	31.48	5.39	37.18	104	201	Average
5350	66.52	66.83	74	-7.48	31.48	5.39	37.18	104	201	Peak
10640	41.95	46.28	54	-12.05	39.62	8.32	52.27	100	172	Average
10640	50.17	54.5	74	-23.83	39.62	8.32	52.27	100	172	Peak
ANTENNA POLARITY & TEST DISTANCE: VERTICAL AT 3 M										
FREQ. (MHz)	EMISSION LEVEL (dBuV/m)	READ LEVEL (dBuV)	LIMIT (dBuV/m)	MARGIN (dB)	ANTENNA FACTOR (dB/m)	CABLE LOSS (dB)	PREAMP FACTOR (dB)	ANTENNA HEIGHT (cm)	TABLE ANGLE (Degree)	REMARK
5014	38.43	39.21	54	-15.57	31.21	5.24	37.23	100	186	Average
5014	59.85	60.63	74	-14.15	31.21	5.24	37.23	100	186	Peak
5320	101.53	101.89			31.45	5.38	37.19	100	186	Average
5320	110.96	111.32			31.45	5.38	37.19	100	186	Peak
5350	51.57	51.88	54	-2.43	31.48	5.39	37.18	100	186	Average
5350	69.68	69.99	74	-4.32	31.48	5.39	37.18	100	186	Peak
10640	41.68	46.01	54	-12.32	39.62	8.32	52.27	100	108	Average
10640	49.85	54.18	74	-24.15	39.62	8.32	52.27	100	108	Peak

REMARKS:

- Emission Level = Read Level + Antenna Factor + Cable Loss - Preamp Factor
Margin value = Emission level – Limit value
- 5320MHz: Fundamental frequency.



A D T

EUT TEST CONDITION		MEASUREMENT DETAIL	
CHANNEL	Channel 100	FREQUENCY RANGE	1GHz ~ 40GHz
INPUT POWER	120Vac, 60 Hz	DETECTOR FUNCTION	Peak (PK) Average (AV)
ENVIRONMENTAL CONDITIONS	25deg. C, 65%RH	TESTED BY	Toby Tian

ANTENNA POLARITY & TEST DISTANCE: HORIZONTAL AT 3 M										
FREQ. (MHz)	EMISSION LEVEL (dBuV/m)	READ LEVEL (dBuV)	LIMIT (dBuV/m)	MARGIN (dB)	ANTENNA FACTOR (dB/m)	CABLE LOSS (dB)	PREAMP FACTOR (dB)	ANTENNA HEIGHT (cm)	TABLE ANGLE (Degree)	REMARK
5458	42.67	42.75	54	-11.33	31.56	5.44	37.08	100	196	Average
5458	60.12	60.2	74	-13.88	31.56	5.44	37.08	100	196	Peak
5470	64.83	64.89	68.2	-3.37	31.57	5.45	37.08	100	196	Peak
5500	94.17	94.14			31.6	5.46	37.03	100	196	Average
5500	104.19	104.16			31.6	5.46	37.03	100	196	Peak
5725	59.57	59.45	68.2	-8.63	31.96	5.59	37.43	100	196	Peak
11000	39.81	44.5	54	-14.19	40.2	8.56	53.45	100	86	Average
11000	49.1	53.79	74	-24.9	40.2	8.56	53.45	100	86	Peak
ANTENNA POLARITY & TEST DISTANCE: VERTICAL AT 3 M										
FREQ. (MHz)	EMISSION LEVEL (dBuV/m)	READ LEVEL (dBuV)	LIMIT (dBuV/m)	MARGIN (dB)	ANTENNA FACTOR (dB/m)	CABLE LOSS (dB)	PREAMP FACTOR (dB)	ANTENNA HEIGHT (cm)	TABLE ANGLE (Degree)	REMARK
5460	43.36	43.44	54	-10.64	31.56	5.44	37.08	102	116	Average
5460	61.23	61.31	74	-12.77	31.56	5.44	37.08	102	116	Peak
5470	65.14	65.2	68.2	-3.06	31.57	5.45	37.08	102	116	Peak
5500	96.42	96.39			31.6	5.46	37.03	102	116	Average
5500	106.1	106.07			31.6	5.46	37.03	102	116	Peak
5725	59.61	59.49	68.2	-8.59	31.96	5.59	37.43	102	116	Peak
11000	39.65	44.34	54	-14.35	40.2	8.56	53.45	100	228	Average
11000	48.42	53.11	74	-25.58	40.2	8.56	53.45	100	228	Peak

REMARKS:

- Emission Level = Read Level + Antenna Factor + Cable Loss - Preamp Factor
Margin value = Emission level – Limit value
- 5500MHz: Fundamental frequency.
- 5470MHz & 5725MHz: Out of restricted band



A D T

EUT TEST CONDITION		MEASUREMENT DETAIL	
CHANNEL	Channel 116	FREQUENCY RANGE	1GHz ~ 40GHz
INPUT POWER	120Vac, 60 Hz	DETECTOR FUNCTION	Peak (PK) Average (AV)
ENVIRONMENTAL CONDITIONS	25deg. C, 65%RH	TESTED BY	Toby Tian

ANTENNA POLARITY & TEST DISTANCE: HORIZONTAL AT 3 M										
FREQ. (MHz)	EMISSION LEVEL (dBuV/m)	READ LEVEL (dBuV)	LIMIT (dBuV/m)	MARGIN (dB)	ANTENNA FACTOR (dB/m)	CABLE LOSS (dB)	PREAMP FACTOR (dB)	ANTENNA HEIGHT (cm)	TABLE ANGLE (Degree)	REMARK
5406	38.07	38.32	54	-15.93	31.52	5.41	37.18	133	158	Average
5406	60.55	60.8	74	-13.45	31.52	5.41	37.18	133	158	Peak
5470	59.11	59.17	68.2	-9.09	31.57	5.45	37.08	133	158	Peak
5580	95	94.95			31.71	5.5	37.16	133	158	Average
5580	104.76	104.71			31.71	5.5	37.16	133	158	Peak
5725	59	58.88	68.2	-9.2	31.96	5.59	37.43	133	158	Peak
11160	41.08	45.66	54	-12.92	40.1	8.71	53.39	100	86	Average
11160	52.02	56.6	74	-21.98	40.1	8.71	53.39	100	86	Peak
ANTENNA POLARITY & TEST DISTANCE: VERTICAL AT 3 M										
FREQ. (MHz)	EMISSION LEVEL (dBuV/m)	READ LEVEL (dBuV)	LIMIT (dBuV/m)	MARGIN (dB)	ANTENNA FACTOR (dB/m)	CABLE LOSS (dB)	PREAMP FACTOR (dB)	ANTENNA HEIGHT (cm)	TABLE ANGLE (Degree)	REMARK
5378	38.32	38.59	54	-15.68	31.51	5.4	37.18	100	120	Average
5378	59.88	60.15	74	-14.12	31.51	5.4	37.18	100	120	Peak
5470	60.17	60.23	68.2	-8.03	31.57	5.45	37.08	100	120	Peak
5580	99.11	99.06			31.71	5.5	37.16	100	120	Average
5580	109.02	108.97			31.71	5.5	37.16	100	120	Peak
5725	59.65	59.53	68.2	-8.55	31.96	5.59	37.43	100	120	Peak
11160	40.87	45.45	54	-13.13	40.1	8.71	53.39	100	228	Average
11160	51.73	56.31	74	-22.27	40.1	8.71	53.39	100	228	Peak

REMARKS:

- Emission Level = Read Level + Antenna Factor + Cable Loss - Preamp Factor
Margin value = Emission level – Limit value
- 5580MHz: Fundamental frequency.
- 5470MHz & 5725MHz: Out of restricted band



A D T

EUT TEST CONDITION		MEASUREMENT DETAIL	
CHANNEL	Channel 120	FREQUENCY RANGE	1GHz ~ 40GHz
INPUT POWER	120Vac, 60 Hz	DETECTOR FUNCTION	Peak (PK) Average (AV)
ENVIRONMENTAL CONDITIONS	25deg. C, 65%RH	TESTED BY	Toby Tian

ANTENNA POLARITY & TEST DISTANCE: HORIZONTAL AT 3 M										
FREQ. (MHz)	EMISSION LEVEL (dBuV/m)	READ LEVEL (dBuV)	LIMIT (dBuV/m)	MARGIN (dB)	ANTENNA FACTOR (dB/m)	CABLE LOSS (dB)	PREAMP FACTOR (dB)	ANTENNA HEIGHT (cm)	TABLE ANGLE (Degree)	REMARK
5408	38.95	39.2	54	-15.05	31.52	5.41	37.18	100	192	Average
5408	59.8	60.05	74	-14.2	31.52	5.41	37.18	100	192	Peak
5470	59.02	59.08	68.2	-9.18	31.57	5.45	37.08	100	192	Peak
5600	97.87	97.74			31.77	5.52	37.16	100	192	Average
5600	107.66	107.53			31.77	5.52	37.16	100	192	Peak
5725	59.23	59.11	68.2	-8.97	31.96	5.59	37.43	100	192	Peak
11200	41.7	46.02	54	-12.3	40.08	8.76	53.16	100	87	Average
11200	52.65	56.97	74	-21.35	40.08	8.76	53.16	100	87	Peak
ANTENNA POLARITY & TEST DISTANCE: VERTICAL AT 3 M										
FREQ. (MHz)	EMISSION LEVEL (dBuV/m)	READ LEVEL (dBuV)	LIMIT (dBuV/m)	MARGIN (dB)	ANTENNA FACTOR (dB/m)	CABLE LOSS (dB)	PREAMP FACTOR (dB)	ANTENNA HEIGHT (cm)	TABLE ANGLE (Degree)	REMARK
5370	39.88	40.17	54	-14.12	31.49	5.4	37.18	102	126	Average
5370	59.49	59.78	74	-14.51	31.49	5.4	37.18	102	126	Peak
5470	57.37	57.43	68.2	-10.83	31.57	5.45	37.08	102	126	Peak
5600	100.51	100.38			31.77	5.52	37.16	102	126	Average
5600	110.02	109.89			31.77	5.52	37.16	102	126	Peak
5724	59.58	59.46	68.2	-8.62	31.96	5.59	37.43	102	126	Peak
11200	41.51	45.83	54	-12.49	40.08	8.76	53.16	100	227	Average
11200	51.59	55.91	74	-22.41	40.08	8.76	53.16	100	227	Peak

REMARKS:

- Emission Level = Read Level + Antenna Factor + Cable Loss - Preamp Factor
Margin value = Emission level – Limit value
- 5600MHz: Fundamental frequency.
- 5470MHz & 5725MHz: Out of restricted band



A D T

EUT TEST CONDITION		MEASUREMENT DETAIL	
CHANNEL	Channel 140	FREQUENCY RANGE	1GHz ~ 40GHz
INPUT POWER	120Vac, 60 Hz	DETECTOR FUNCTION	Peak (PK) Average (AV)
ENVIRONMENTAL CONDITIONS	25deg. C, 65%RH	TESTED BY	Toby Tian

ANTENNA POLARITY & TEST DISTANCE: HORIZONTAL AT 3 M										
FREQ. (MHz)	EMISSION LEVEL (dBuV/m)	READ LEVEL (dBuV)	LIMIT (dBuV/m)	MARGIN (dB)	ANTENNA FACTOR (dB/m)	CABLE LOSS (dB)	PREAMP FACTOR (dB)	ANTENNA HEIGHT (cm)	TABLE ANGLE (Degree)	REMARK
5432	37.92	38.08	54	-16.08	31.55	5.42	37.13	100	176	Average
5432	59.2	59.36	74	-14.8	31.55	5.42	37.13	100	176	Peak
5470	59.1	59.16	68.2	-9.1	31.57	5.45	37.08	100	176	Peak
5700	94.81	94.74			31.9	5.57	37.4	100	176	Average
5700	104.28	104.21			31.9	5.57	37.4	100	176	Peak
5725	64.8	64.68	68.2	-3.4	31.96	5.59	37.43	100	176	Peak
11400	42.22	45.44	54	-11.78	39.96	8.95	52.13	100	86	Average
11400	52.44	55.66	74	-21.56	39.96	8.95	52.13	100	86	Peak

ANTENNA POLARITY & TEST DISTANCE: VERTICAL AT 3 M										
FREQ. (MHz)	EMISSION LEVEL (dBuV/m)	READ LEVEL (dBuV)	LIMIT (dBuV/m)	MARGIN (dB)	ANTENNA FACTOR (dB/m)	CABLE LOSS (dB)	PREAMP FACTOR (dB)	ANTENNA HEIGHT (cm)	TABLE ANGLE (Degree)	REMARK
5448	37.92	38.05	54	-16.08	31.56	5.44	37.13	120	127	Average
5448	59.86	59.99	74	-14.14	31.56	5.44	37.13	120	127	Peak
5470	57.59	57.65	68.2	-10.61	31.57	5.45	37.08	120	127	Peak
5700	98.57	98.5			31.9	5.57	37.4	120	127	Average
5700	108.32	108.25			31.9	5.57	37.4	120	127	Peak
5725	66.94	66.82	68.2	-1.26	31.96	5.59	37.43	120	127	Peak
11400	42.01	45.23	54	-11.99	39.96	8.95	52.13	100	228	Average
11400	51.87	55.09	74	-22.13	39.96	8.95	52.13	100	228	Peak

REMARKS:

- Emission Level = Read Level + Antenna Factor + Cable Loss - Preamp Factor
Margin value = Emission level – Limit value
- 5700MHz: Fundamental frequency.
- 5470MHz & 5725MHz: Out of restricted band



A D T

EUT TEST CONDITION		MEASUREMENT DETAIL	
CHANNEL	Channel 149	FREQUENCY RANGE	1GHz ~ 40GHz
INPUT POWER	120Vac, 60 Hz	DETECTOR FUNCTION	Peak (PK) Average (AV)
ENVIRONMENTAL CONDITIONS	25deg. C, 65%RH	TESTED BY	Toby Tian

ANTENNA POLARITY & TEST DISTANCE: HORIZONTAL AT 3 M

FREQ. (MHz)	EMISSION LEVEL (dBuV/m)	READ LEVEL (dBuV)	LIMIT (dBuV/m)	MARGIN (dB)	ANTENNA FACTOR (dB/m)	CABLE LOSS (dB)	PREAMP FACTOR (dB)	ANTENNA HEIGHT (cm)	TABLE ANGLE (Degree)	REMARK
5714	63.6	63.51	68.2	-4.6	31.93	5.59	37.43	115	171	Peak
5725	74.18	74.06	78.2	-4.02	31.96	5.59	37.43	115	171	Peak
5745	99.15	99.03			31.99	5.6	37.47	115	171	Average
5745	108.6	108.48			31.99	5.6	37.47	115	171	Peak
5850	59.44	59.14	78.2	-18.76	32.15	5.66	37.51	115	171	Peak
5861	60.5	60.16	68.2	-7.7	32.18	5.66	37.5	115	171	Peak
11490	42.24	46.11	54	-11.76	39.91	9.05	52.83	100	320	Average
11490	52.71	56.58	74	-21.29	39.91	9.05	52.83	100	320	Peak

ANTENNA POLARITY & TEST DISTANCE: VERTICAL AT 3 M

FREQ. (MHz)	EMISSION LEVEL (dBuV/m)	READ LEVEL (dBuV)	LIMIT (dBuV/m)	MARGIN (dB)	ANTENNA FACTOR (dB/m)	CABLE LOSS (dB)	PREAMP FACTOR (dB)	ANTENNA HEIGHT (cm)	TABLE ANGLE (Degree)	REMARK
5714	63.78	63.69	68.2	-4.42	31.93	5.59	37.43	100	140	Peak
5725	73.94	73.82	78.2	-4.26	31.96	5.59	37.43	100	140	Peak
5745	100.66	100.54			31.99	5.6	37.47	100	140	Average
5745	110.09	109.97			31.99	5.6	37.47	100	140	Peak
5850	58.72	58.42	78.2	-19.48	32.15	5.66	37.51	100	140	Peak
5861	59.03	58.69	68.2	-9.17	32.18	5.66	37.5	100	140	Peak
11490	42.33	46.2	54	-11.67	39.91	9.05	52.83	100	60	Average
11490	53.54	57.41	74	-20.46	39.91	9.05	52.83	100	60	Peak

REMARKS:

- Emission Level = Read Level + Antenna Factor + Cable Loss - Preamp Factor
Margin value = Emission level – Limit value
- 5745MHz: Fundamental frequency.
- 5714, 5725MHz, 5850 & 5861MHz: Out of restricted band



A D T

EUT TEST CONDITION		MEASUREMENT DETAIL	
CHANNEL	Channel 157	FREQUENCY RANGE	1GHz ~ 40GHz
INPUT POWER	120Vac, 60 Hz	DETECTOR FUNCTION	Peak (PK) Average (AV)
ENVIRONMENTAL CONDITIONS	25deg. C, 65%RH	TESTED BY	Toby Tian

ANTENNA POLARITY & TEST DISTANCE: HORIZONTAL AT 3 M

FREQ. (MHz)	EMISSION LEVEL (dBuV/m)	READ LEVEL (dBuV)	LIMIT (dBuV/m)	MARGIN (dB)	ANTENNA FACTOR (dB/m)	CABLE LOSS (dB)	PREAMP FACTOR (dB)	ANTENNA HEIGHT (cm)	TABLE ANGLE (Degree)	REMARK
5714	59.89	59.8	68.2	-8.31	31.93	5.59	37.43	114	171	Peak
5725	59.72	59.6	78.2	-18.48	31.96	5.59	37.43	114	171	Peak
5785	101.37	101.25			32.04	5.62	37.54	114	171	Average
5785	110.62	110.5			32.04	5.62	37.54	114	171	Peak
5850	60.94	60.64	78.2	-17.26	32.15	5.66	37.51	114	171	Peak
5861	61.18	60.84	68.2	-7.02	32.18	5.66	37.5	114	171	Peak
11570	41.47	45.93	54	-12.53	39.78	9.09	53.33	100	314	Average
11570	51.15	55.61	74	-22.85	39.78	9.09	53.33	100	314	Peak

ANTENNA POLARITY & TEST DISTANCE: VERTICAL AT 3 M

FREQ. (MHz)	EMISSION LEVEL (dBuV/m)	READ LEVEL (dBuV)	LIMIT (dBuV/m)	MARGIN (dB)	ANTENNA FACTOR (dB/m)	CABLE LOSS (dB)	PREAMP FACTOR (dB)	ANTENNA HEIGHT (cm)	TABLE ANGLE (Degree)	REMARK
5714	59.45	59.36	68.2	-8.75	31.93	5.59	37.43	100	144	Peak
5725	60.5	60.38	78.2	-17.7	31.96	5.59	37.43	100	144	Peak
5785	102.26	102.14			32.04	5.62	37.54	100	144	Average
5785	111.48	111.36			32.04	5.62	37.54	100	144	Peak
5850	62.13	61.83	78.2	-16.07	32.15	5.66	37.51	100	144	Peak
5861	61.22	60.88	68.2	-6.98	32.18	5.66	37.5	100	144	Peak
11570	41.6	46.06	54	-12.4	39.78	9.09	53.33	100	96	Average
11570	51.49	55.95	74	-22.51	39.78	9.09	53.33	100	96	Peak

REMARKS:

- Emission Level = Read Level + Antenna Factor + Cable Loss - Preamp Factor
Margin value = Emission level – Limit value
- 5785MHz: Fundamental frequency.
- 5714, 5725MHz, 5850 & 5861MHz: Out of restricted band



A D T

EUT TEST CONDITION		MEASUREMENT DETAIL	
CHANNEL	Channel 165	FREQUENCY RANGE	1GHz ~ 40GHz
INPUT POWER	120Vac, 60 Hz	DETECTOR FUNCTION	Peak (PK) Average (AV)
ENVIRONMENTAL CONDITIONS	25deg. C, 65%RH	TESTED BY	Toby Tian

ANTENNA POLARITY & TEST DISTANCE: HORIZONTAL AT 3 M

FREQ. (MHz)	EMISSION LEVEL (dBuV/m)	READ LEVEL (dBuV)	LIMIT (dBuV/m)	MARGIN (dB)	ANTENNA FACTOR (dB/m)	CABLE LOSS (dB)	PREAMP FACTOR (dB)	ANTENNA HEIGHT (cm)	TABLE ANGLE (Degree)	REMARK
5714	60.29	60.2	68.2	-7.91	31.93	5.59	37.43	114	176	Peak
5725	59.1	58.98	78.2	-19.1	31.96	5.59	37.43	114	176	Peak
5825	101.43	101.2			32.12	5.64	37.53	114	176	Average
5825	110.55	110.32			32.12	5.64	37.53	114	176	Peak
5850	72.69	72.39	78.2	-5.51	32.15	5.66	37.51	114	176	Peak
5861	66.09	65.75	68.2	-2.11	32.18	5.66	37.5	114	176	Peak
11650	41.75	46.33	54	-12.25	39.65	9.12	53.35	100	278	Average
11650	52.49	57.07	74	-21.51	39.65	9.12	53.35	100	278	Peak

ANTENNA POLARITY & TEST DISTANCE: VERTICAL AT 3 M

FREQ. (MHz)	EMISSION LEVEL (dBuV/m)	READ LEVEL (dBuV)	LIMIT (dBuV/m)	MARGIN (dB)	ANTENNA FACTOR (dB/m)	CABLE LOSS (dB)	PREAMP FACTOR (dB)	ANTENNA HEIGHT (cm)	TABLE ANGLE (Degree)	REMARK
5714	60.19	60.1	68.2	-8.01	31.93	5.59	37.43	100	144	Peak
5725	59.19	59.07	78.2	-19.01	31.96	5.59	37.43	100	144	Peak
5825	101.9	101.67			32.12	5.64	37.53	100	144	Average
5825	111.39	111.16			32.12	5.64	37.53	100	144	Peak
5850	72.7	72.4	78.2	-5.5	32.15	5.66	37.51	100	144	Peak
5861	66.2	65.86	68.2	-2	32.18	5.66	37.5	100	144	Peak
11650	41.82	46.4	54	-12.18	39.65	9.12	53.35	100	42	Average
11650	52.57	57.15	74	-21.43	39.65	9.12	53.35	100	42	Peak

REMARKS:

- Emission Level = Read Level + Antenna Factor + Cable Loss - Preamp Factor
Margin value = Emission level – Limit value
- 5825MHz: Fundamental frequency.
- 5714, 5725MHz, 5850 & 5861MHz: Out of restricted band



A D T

BELOW 1GHz WORST-CASE DATA:

Mode A

802.11a

EUT TEST CONDITION		MEASUREMENT DETAIL	
CHANNEL	Channel 36	FREQUENCY RANGE	30MHz ~ 1GHz
INPUT POWER	120Vac, 60 Hz	DETECTOR FUNCTION	Peak (PK)
ENVIRONMENTAL CONDITIONS	25deg. C, 65%RH	TESTED BY	Toby Tian

ANTENNA POLARITY & TEST DISTANCE: HORIZONTAL AT 3 M

FREQ. (MHz)	EMISSION LEVEL (dBuV/m)	READ LEVEL (dBuV)	LIMIT (dBuV/m)	MARGIN (dB)	ANTENNA FACTOR (dB/m)	CABLE LOSS (dB)	PREAMP FACTOR (dB)	ANTENNA HEIGHT (cm)	TABLE ANGLE (Degree)	REMARK
133.14	28.97	47.64	43.5	-14.53	11.88	1.26	31.81	123	279	Peak
179.85	25.78	45.28	43.5	-17.72	10.83	1.5	31.83	111	360	Peak
206.85	29.62	50	43.5	-13.88	9.65	1.63	31.66	102	84	Peak
500.9	22.47	33.98	46	-23.53	17.33	2.78	31.62	133	201	Peak
675.9	24.82	32.78	46	-21.18	20.53	3.34	31.83	135	170	Peak
773.9	27.42	33.28	46	-18.58	21.86	3.63	31.35	120	148	Peak

ANTENNA POLARITY & TEST DISTANCE: VERTICAL AT 3 M

FREQ. (MHz)	EMISSION LEVEL (dBuV/m)	READ LEVEL (dBuV)	LIMIT (dBuV/m)	MARGIN (dB)	ANTENNA FACTOR (dB/m)	CABLE LOSS (dB)	PREAMP FACTOR (dB)	ANTENNA HEIGHT (cm)	TABLE ANGLE (Degree)	REMARK
30.81	26.99	45.4	40	-13.01	12.14	0.57	31.12	107	20	Peak
87.24	26.77	49.33	40	-13.23	8.25	1.01	31.82	108	62	Peak
138.54	25.52	43.62	43.5	-17.98	12.27	1.29	31.66	114	57	Peak
585.6	24.79	34.59	46	-21.21	19.28	3.05	32.13	109	20	Peak
715.8	25.66	32.83	46	-20.34	21.04	3.48	31.69	131	298	Peak
775.3	27.91	33.77	46	-18.09	21.87	3.63	31.36	118	169	Peak

REMARKS: Emission Level = Read Level + Antenna Factor + Cable Loss - Preamp Factor

Margin value = Emission level – Limit value



A D T

EUT TEST CONDITION		MEASUREMENT DETAIL	
CHANNEL	Channel 44	FREQUENCY RANGE	30MHz ~ 1GHz
INPUT POWER	120Vac, 60 Hz	DETECTOR FUNCTION	Peak (PK)
ENVIRONMENTAL CONDITIONS	25deg. C, 65%RH	TESTED BY	Toby Tian

ANTENNA POLARITY & TEST DISTANCE: HORIZONTAL AT 3 M										
FREQ. (MHz)	EMISSION LEVEL (dBuV/m)	READ LEVEL (dBuV)	LIMIT (dBuV/m)	MARGIN (dB)	ANTENNA FACTOR (dB/m)	CABLE LOSS (dB)	PREAMP FACTOR (dB)	ANTENNA HEIGHT (cm)	TABLE ANGLE (Degree)	REMARK
143.4	28.27	46.12	43.5	-15.23	12.47	1.31	31.63	137	277	Peak
187.95	29.15	49.12	43.5	-14.35	10.19	1.54	31.7	128	287	Peak
205.23	28.94	49.39	43.5	-14.56	9.6	1.62	31.67	116	210	Peak
553.4	23.04	33.52	46	-22.96	18.55	2.96	31.99	109	82	Peak
677.3	24.56	32.51	46	-21.44	20.54	3.34	31.83	114	118	Peak
755.7	26.83	33.02	46	-19.17	21.6	3.59	31.38	116	322	Peak
ANTENNA POLARITY & TEST DISTANCE: VERTICAL AT 3 M										
FREQ. (MHz)	EMISSION LEVEL (dBuV/m)	READ LEVEL (dBuV)	LIMIT (dBuV/m)	MARGIN (dB)	ANTENNA FACTOR (dB/m)	CABLE LOSS (dB)	PREAMP FACTOR (dB)	ANTENNA HEIGHT (cm)	TABLE ANGLE (Degree)	REMARK
31.08	27.32	45.73	40	-12.68	12.14	0.57	31.12	123	355	Peak
86.97	26.74	49.3	40	-13.26	8.25	1.01	31.82	117	84	Peak
133.68	25.69	44.27	43.5	-17.81	11.94	1.26	31.78	132	266	Peak
542.9	24.99	35.57	46	-21.01	18.3	2.92	31.8	139	356	Peak
682.2	25.71	33.59	46	-20.29	20.6	3.36	31.84	128	166	Peak
787.9	27.59	33.29	46	-18.41	22.05	3.66	31.41	104	25	Peak
31.08	27.32	45.73	40	-12.68	12.14	0.57	31.12	123	355	Peak

REMARKS: Emission Level = Read Level + Antenna Factor + Cable Loss - Preamp Factor
 Margin value = Emission level – Limit value



A D T

EUT TEST CONDITION		MEASUREMENT DETAIL	
CHANNEL	Channel 48	FREQUENCY RANGE	30MHz ~ 1GHz
INPUT POWER	120Vac, 60 Hz	DETECTOR FUNCTION	Peak (PK)
ENVIRONMENTAL CONDITIONS	25deg. C, 65%RH	TESTED BY	Toby Tian

ANTENNA POLARITY & TEST DISTANCE: HORIZONTAL AT 3 M										
FREQ. (MHz)	EMISSION LEVEL (dBuV/m)	READ LEVEL (dBuV)	LIMIT (dBuV/m)	MARGIN (dB)	ANTENNA FACTOR (dB/m)	CABLE LOSS (dB)	PREAMP FACTOR (dB)	ANTENNA HEIGHT (cm)	TABLE ANGLE (Degree)	REMARK
141.51	28.5	46.42	43.5	-15	12.41	1.3	31.63	139	266	Peak
187.95	28.91	48.88	43.5	-14.59	10.19	1.54	31.7	126	39	Peak
207.39	28.78	49.1	43.5	-14.72	9.69	1.63	31.64	108	168	Peak
611.5	24.18	33.41	46	-21.82	19.74	3.12	32.09	100	80	Peak
715.8	26.11	33.28	46	-19.89	21.04	3.48	31.69	131	316	Peak
786.5	28.55	34.26	46	-17.45	22.04	3.66	31.41	125	161	Peak
ANTENNA POLARITY & TEST DISTANCE: VERTICAL AT 3 M										
FREQ. (MHz)	EMISSION LEVEL (dBuV/m)	READ LEVEL (dBuV)	LIMIT (dBuV/m)	MARGIN (dB)	ANTENNA FACTOR (dB/m)	CABLE LOSS (dB)	PREAMP FACTOR (dB)	ANTENNA HEIGHT (cm)	TABLE ANGLE (Degree)	REMARK
31.08	26.43	44.84	40	-13.57	12.14	0.57	31.12	105	9	Peak
87.24	27.34	49.9	40	-12.66	8.25	1.01	31.82	116	276	Peak
134.49	26.68	45.16	43.5	-16.82	12.01	1.27	31.76	130	77	Peak
591.9	25.25	34.94	46	-20.75	19.41	3.06	32.16	131	16	Peak
655.6	25.05	33.49	46	-20.95	20.28	3.26	31.98	135	198	Peak
785.8	27.3	33.03	46	-18.7	22.02	3.66	31.41	111	305	Peak

REMARKS: Emission Level = Read Level + Antenna Factor + Cable Loss - Preamp Factor

Margin value = Emission level – Limit value



A D T

EUT TEST CONDITION		MEASUREMENT DETAIL	
CHANNEL	Channel 52	FREQUENCY RANGE	30MHz ~ 1GHz
INPUT POWER	120Vac, 60 Hz	DETECTOR FUNCTION	Peak (PK)
ENVIRONMENTAL CONDITIONS	25deg. C, 65%RH	TESTED BY	Toby Tian

ANTENNA POLARITY & TEST DISTANCE: HORIZONTAL AT 3 M										
FREQ. (MHz)	EMISSION LEVEL (dBuV/m)	READ LEVEL (dBuV)	LIMIT (dBuV/m)	MARGIN (dB)	ANTENNA FACTOR (dB/m)	CABLE LOSS (dB)	PREAMP FACTOR (dB)	ANTENNA HEIGHT (cm)	TABLE ANGLE (Degree)	REMARK
56.46	19.8	37.99	40	-20.2	12.35	0.8	31.34	140	28	Peak
139.08	27.83	45.93	43.5	-15.67	12.27	1.29	31.66	115	191	Peak
202.53	25.34	45.97	43.5	-18.16	9.48	1.61	31.72	132	224	Peak
304.9	21.43	38.19	46	-24.57	13.06	2.07	31.89	139	314	Peak
477.8	21.38	33.64	46	-24.62	16.89	2.71	31.86	138	162	Peak
618.5	24.34	33.53	46	-21.66	19.83	3.14	32.16	115	5	Peak
ANTENNA POLARITY & TEST DISTANCE: VERTICAL AT 3 M										
FREQ. (MHz)	EMISSION LEVEL (dBuV/m)	READ LEVEL (dBuV)	LIMIT (dBuV/m)	MARGIN (dB)	ANTENNA FACTOR (dB/m)	CABLE LOSS (dB)	PREAMP FACTOR (dB)	ANTENNA HEIGHT (cm)	TABLE ANGLE (Degree)	REMARK
30.27	24.48	43.07	40	-15.52	11.98	0.57	31.14	117	38	Peak
68.34	24.4	44.39	40	-15.6	10.89	0.89	31.77	127	72	Peak
137.46	26.49	44.69	43.5	-17.01	12.21	1.28	31.69	118	2	Peak
308.4	18.1	34.8	46	-27.9	13.15	2.08	31.93	104	210	Peak
477.1	21.27	33.56	46	-24.73	16.87	2.7	31.86	120	288	Peak
592.6	24.71	34.38	46	-21.29	19.43	3.07	32.17	100	202	Peak

REMARKS: Emission Level = Read Level + Antenna Factor + Cable Loss - Preamp Factor
Margin value = Emission level – Limit value



A D T

EUT TEST CONDITION		MEASUREMENT DETAIL	
CHANNEL	Channel 60	FREQUENCY RANGE	30MHz ~ 1GHz
INPUT POWER	120Vac, 60 Hz	DETECTOR FUNCTION	Peak (PK)
ENVIRONMENTAL CONDITIONS	25deg. C, 65%RH	TESTED BY	Toby Tian

ANTENNA POLARITY & TEST DISTANCE: HORIZONTAL AT 3 M										
FREQ. (MHz)	EMISSION LEVEL (dBuV/m)	READ LEVEL (dBuV)	LIMIT (dBuV/m)	MARGIN (dB)	ANTENNA FACTOR (dB/m)	CABLE LOSS (dB)	PREAMP FACTOR (dB)	ANTENNA HEIGHT (cm)	TABLE ANGLE (Degree)	REMARK
43.77	20.49	37.3	40	-19.51	13.59	0.71	31.11	120	320	Peak
137.73	27.36	45.56	43.5	-16.14	12.21	1.28	31.69	117	176	Peak
200.37	24.96	45.71	43.5	-18.54	9.4	1.6	31.75	114	220	Peak
308.4	21.34	38.04	46	-24.66	13.15	2.08	31.93	109	294	Peak
372.8	21.69	36.62	46	-24.31	14.68	2.32	31.93	134	218	Peak
559.7	23.32	33.73	46	-22.68	18.68	2.97	32.06	113	184	Peak
ANTENNA POLARITY & TEST DISTANCE: VERTICAL AT 3 M										
FREQ. (MHz)	EMISSION LEVEL (dBuV/m)	READ LEVEL (dBuV)	LIMIT (dBuV/m)	MARGIN (dB)	ANTENNA FACTOR (dB/m)	CABLE LOSS (dB)	PREAMP FACTOR (dB)	ANTENNA HEIGHT (cm)	TABLE ANGLE (Degree)	REMARK
30.54	24.23	42.64	40	-15.77	12.14	0.57	31.12	110	6	Peak
68.61	24.07	44.06	40	-15.93	10.89	0.89	31.77	101	290	Peak
138.54	26.63	44.73	43.5	-16.87	12.27	1.29	31.66	101	177	Peak
349.7	18.83	34.29	46	-27.17	14.15	2.23	31.84	104	174	Peak
436.5	20.76	34.14	46	-25.24	16.06	2.56	32	111	289	Peak
500.2	23.35	34.86	46	-22.65	17.33	2.78	31.62	138	101	Peak

REMARKS: Emission Level = Read Level + Antenna Factor + Cable Loss - Preamp Factor

Margin value = Emission level – Limit value



A D T

EUT TEST CONDITION		MEASUREMENT DETAIL	
CHANNEL	Channel 64	FREQUENCY RANGE	30MHz ~ 1GHz
INPUT POWER	120Vac, 60 Hz	DETECTOR FUNCTION	Peak (PK)
ENVIRONMENTAL CONDITIONS	25deg. C, 65%RH	TESTED BY	Toby Tian

ANTENNA POLARITY & TEST DISTANCE: HORIZONTAL AT 3 M										
FREQ. (MHz)	EMISSION LEVEL (dBuV/m)	READ LEVEL (dBuV)	LIMIT (dBuV/m)	MARGIN (dB)	ANTENNA FACTOR (dB/m)	CABLE LOSS (dB)	PREAMP FACTOR (dB)	ANTENNA HEIGHT (cm)	TABLE ANGLE (Degree)	REMARK
43.23	19.4	36.21	40	-20.6	13.59	0.71	31.11	105	109	Peak
138	27.65	45.85	43.5	-15.85	12.21	1.28	31.69	124	5	Peak
201.45	25.06	45.76	43.5	-18.44	9.44	1.6	31.74	120	323	Peak
302.8	21.8	38.6	46	-24.2	13.01	2.06	31.87	121	96	Peak
457.5	22.81	35.68	46	-23.19	16.48	2.64	31.99	107	11	Peak
582.8	24.19	34.07	46	-21.81	19.21	3.04	32.13	128	250	Peak
ANTENNA POLARITY & TEST DISTANCE: VERTICAL AT 3 M										
FREQ. (MHz)	EMISSION LEVEL (dBuV/m)	READ LEVEL (dBuV)	LIMIT (dBuV/m)	MARGIN (dB)	ANTENNA FACTOR (dB/m)	CABLE LOSS (dB)	PREAMP FACTOR (dB)	ANTENNA HEIGHT (cm)	TABLE ANGLE (Degree)	REMARK
30.54	24.04	42.45	40	-15.96	12.14	0.57	31.12	129	47	Peak
67.8	23.57	43.42	40	-16.43	11	0.88	31.73	135	273	Peak
137.19	26.51	44.71	43.5	-16.99	12.21	1.28	31.69	106	280	Peak
341.3	18.33	34.01	46	-27.67	13.94	2.2	31.82	137	359	Peak
452.6	20.7	33.66	46	-25.3	16.39	2.63	31.98	125	350	Peak
627.6	24.1	33.14	46	-21.9	19.94	3.17	32.15	120	240	Peak

REMARKS: Emission Level = Read Level + Antenna Factor + Cable Loss - Preamp Factor
 Margin value = Emission level – Limit value



A D T

EUT TEST CONDITION		MEASUREMENT DETAIL	
CHANNEL	Channel 100	FREQUENCY RANGE	30MHz ~ 1GHz
INPUT POWER	120Vac, 60 Hz	DETECTOR FUNCTION	Peak (PK)
ENVIRONMENTAL CONDITIONS	25deg. C, 65%RH	TESTED BY	Toby Tian

ANTENNA POLARITY & TEST DISTANCE: HORIZONTAL AT 3 M										
FREQ. (MHz)	EMISSION LEVEL (dBuV/m)	READ LEVEL (dBuV)	LIMIT (dBuV/m)	MARGIN (dB)	ANTENNA FACTOR (dB/m)	CABLE LOSS (dB)	PREAMP FACTOR (dB)	ANTENNA HEIGHT (cm)	TABLE ANGLE (Degree)	REMARK
45.12	21.67	38.59	40	-18.33	13.5	0.74	31.16	123	59	Peak
136.65	27.77	46.06	43.5	-15.73	12.14	1.28	31.71	139	355	Peak
201.18	25.96	46.71	43.5	-17.54	9.4	1.6	31.75	133	72	Peak
304.9	21.41	38.17	46	-24.59	13.06	2.07	31.89	132	230	Peak
436.5	20.73	34.11	46	-25.27	16.06	2.56	32	110	273	Peak
541.5	22.83	33.4	46	-23.17	18.26	2.92	31.75	111	45	Peak

ANTENNA POLARITY & TEST DISTANCE: VERTICAL AT 3 M										
FREQ. (MHz)	EMISSION LEVEL (dBuV/m)	READ LEVEL (dBuV)	LIMIT (dBuV/m)	MARGIN (dB)	ANTENNA FACTOR (dB/m)	CABLE LOSS (dB)	PREAMP FACTOR (dB)	ANTENNA HEIGHT (cm)	TABLE ANGLE (Degree)	REMARK
30.54	24.58	42.99	40	-15.42	12.14	0.57	31.12	105	11	Peak
67.8	24.72	44.57	40	-15.28	11	0.88	31.73	112	252	Peak
138.81	27.56	45.66	43.5	-15.94	12.27	1.29	31.66	126	134	Peak
310.5	18.53	35.19	46	-27.47	13.2	2.09	31.95	129	287	Peak
500.9	23.44	34.95	46	-22.56	17.33	2.78	31.62	135	118	Peak
607.3	26.69	36.02	46	-19.31	19.69	3.11	32.13	118	310	Peak

REMARKS: Emission Level = Read Level + Antenna Factor + Cable Loss - Preamp Factor
 Margin value = Emission level – Limit value



A D T

EUT TEST CONDITION		MEASUREMENT DETAIL	
CHANNEL	Channel 116	FREQUENCY RANGE	30MHz ~ 1GHz
INPUT POWER	120Vac, 60 Hz	DETECTOR FUNCTION	Peak (PK)
ENVIRONMENTAL CONDITIONS	25deg. C, 65%RH	TESTED BY	Toby Tian

ANTENNA POLARITY & TEST DISTANCE: HORIZONTAL AT 3 M										
FREQ. (MHz)	EMISSION LEVEL (dBuV/m)	READ LEVEL (dBuV)	LIMIT (dBuV/m)	MARGIN (dB)	ANTENNA FACTOR (dB/m)	CABLE LOSS (dB)	PREAMP FACTOR (dB)	ANTENNA HEIGHT (cm)	TABLE ANGLE (Degree)	REMARK
43.77	18.2	35.01	40	-21.8	13.59	0.71	31.11	108	142	Peak
137.73	27.52	45.72	43.5	-15.98	12.21	1.28	31.69	139	158	Peak
202.26	25.01	45.64	43.5	-18.49	9.48	1.61	31.72	127	121	Peak
304.9	20.81	37.57	46	-25.19	13.06	2.07	31.89	114	180	Peak
409.9	19.51	33.5	46	-26.49	15.54	2.46	31.99	111	249	Peak
500.2	23.14	34.65	46	-22.86	17.33	2.78	31.62	110	170	Peak
ANTENNA POLARITY & TEST DISTANCE: VERTICAL AT 3 M										
FREQ. (MHz)	EMISSION LEVEL (dBuV/m)	READ LEVEL (dBuV)	LIMIT (dBuV/m)	MARGIN (dB)	ANTENNA FACTOR (dB/m)	CABLE LOSS (dB)	PREAMP FACTOR (dB)	ANTENNA HEIGHT (cm)	TABLE ANGLE (Degree)	REMARK
30	24.35	42.94	40	-15.65	11.98	0.57	31.14	104	315	Peak
67.53	25.59	45.44	40	-14.41	11	0.88	31.73	102	168	Peak
137.46	26.77	44.97	43.5	-16.73	12.21	1.28	31.69	103	208	Peak
330.1	18.52	34.51	46	-27.48	13.66	2.16	31.81	128	318	Peak
458.2	21.24	34.11	46	-24.76	16.48	2.64	31.99	115	200	Peak
554.1	23.43	33.91	46	-22.57	18.55	2.96	31.99	136	278	Peak

REMARKS: Emission Level = Read Level + Antenna Factor + Cable Loss - Preamp Factor
 Margin value = Emission level – Limit value



A D T

EUT TEST CONDITION		MEASUREMENT DETAIL	
CHANNEL	Channel 120	FREQUENCY RANGE	30MHz ~ 1GHz
INPUT POWER	120Vac, 60 Hz	DETECTOR FUNCTION	Peak (PK)
ENVIRONMENTAL CONDITIONS	25deg. C, 65%RH	TESTED BY	Toby Tian

ANTENNA POLARITY & TEST DISTANCE: HORIZONTAL AT 3 M										
FREQ. (MHz)	EMISSION LEVEL (dBuV/m)	READ LEVEL (dBuV)	LIMIT (dBuV/m)	MARGIN (dB)	ANTENNA FACTOR (dB/m)	CABLE LOSS (dB)	PREAMP FACTOR (dB)	ANTENNA HEIGHT (cm)	TABLE ANGLE (Degree)	REMARK
45.12	15.39	32.31	40	-24.61	13.5	0.74	31.16	102	259	Peak
133.68	25.37	43.95	43.5	-18.13	11.94	1.26	31.78	120	321	Peak
191.19	23.29	43.44	43.5	-20.21	9.98	1.55	31.68	107	272	Peak
309.8	20.53	37.22	46	-25.47	13.17	2.08	31.94	117	62	Peak
462.4	19.62	32.34	46	-26.38	16.58	2.66	31.96	136	283	Peak
625.5	22.74	31.8	46	-23.26	19.92	3.17	32.15	121	348	Peak

ANTENNA POLARITY & TEST DISTANCE: VERTICAL AT 3 M										
FREQ. (MHz)	EMISSION LEVEL (dBuV/m)	READ LEVEL (dBuV)	LIMIT (dBuV/m)	MARGIN (dB)	ANTENNA FACTOR (dB/m)	CABLE LOSS (dB)	PREAMP FACTOR (dB)	ANTENNA HEIGHT (cm)	TABLE ANGLE (Degree)	REMARK
31.08	23.28	41.69	40	-16.72	12.14	0.57	31.12	127	359	Peak
63.75	22.67	41.88	40	-17.33	11.47	0.86	31.54	129	44	Peak
134.76	24.94	43.42	43.5	-18.56	12.01	1.27	31.76	127	256	Peak
345.5	17.22	32.81	46	-28.78	14.03	2.21	31.83	133	56	Peak
512.8	21.37	32.51	46	-24.63	17.62	2.82	31.58	110	312	Peak
628.3	23.95	32.98	46	-22.05	19.95	3.17	32.15	110	312	Peak

REMARKS: Emission Level = Read Level + Antenna Factor + Cable Loss - Preamp Factor
 Margin value = Emission level – Limit value



A D T

EUT TEST CONDITION		MEASUREMENT DETAIL	
CHANNEL	Channel 140	FREQUENCY RANGE	30MHz ~ 1GHz
INPUT POWER	120Vac, 60 Hz	DETECTOR FUNCTION	Peak (PK)
ENVIRONMENTAL CONDITIONS	25deg. C, 65%RH	TESTED BY	Toby Tian

ANTENNA POLARITY & TEST DISTANCE: HORIZONTAL AT 3 M										
FREQ. (MHz)	EMISSION LEVEL (dBuV/m)	READ LEVEL (dBuV)	LIMIT (dBuV/m)	MARGIN (dB)	ANTENNA FACTOR (dB/m)	CABLE LOSS (dB)	PREAMP FACTOR (dB)	ANTENNA HEIGHT (cm)	TABLE ANGLE (Degree)	REMARK
45.12	21.1	38.02	40	-18.9	13.5	0.74	31.16	126	176	Peak
138.81	27.1	45.2	43.5	-16.4	12.27	1.29	31.66	115	40	Peak
192.54	24.47	44.77	43.5	-19.03	9.84	1.56	31.7	122	89	Peak
300.7	23.53	40.37	46	-22.47	12.96	2.05	31.85	132	11	Peak
393.8	19.59	34.08	46	-26.41	15.19	2.4	32.08	137	270	Peak
559.7	23.1	33.51	46	-22.9	18.68	2.97	32.06	119	297	Peak
ANTENNA POLARITY & TEST DISTANCE: VERTICAL AT 3 M										
FREQ. (MHz)	EMISSION LEVEL (dBuV/m)	READ LEVEL (dBuV)	LIMIT (dBuV/m)	MARGIN (dB)	ANTENNA FACTOR (dB/m)	CABLE LOSS (dB)	PREAMP FACTOR (dB)	ANTENNA HEIGHT (cm)	TABLE ANGLE (Degree)	REMARK
30.54	24.57	42.98	40	-15.43	12.14	0.57	31.12	112	353	Peak
68.34	24.87	44.86	40	-15.13	10.89	0.89	31.77	133	234	Peak
138.27	27.21	45.31	43.5	-16.29	12.27	1.29	31.66	139	218	Peak
311.9	18.96	35.56	46	-27.04	13.24	2.1	31.94	117	236	Peak
428.8	19.86	33.43	46	-26.14	15.91	2.53	32.01	109	288	Peak
500.2	23.39	34.9	46	-22.61	17.33	2.78	31.62	120	199	Peak

REMARKS: Emission Level = Read Level + Antenna Factor + Cable Loss - Preamp Factor
 Margin value = Emission level – Limit value



A D T

EUT TEST CONDITION		MEASUREMENT DETAIL	
CHANNEL	Channel 149	FREQUENCY RANGE	30MHz ~ 1GHz
INPUT POWER	120Vac, 60 Hz	DETECTOR FUNCTION	Peak (PK)
ENVIRONMENTAL CONDITIONS	25deg. C, 65%RH	TESTED BY	Toby Tian

ANTENNA POLARITY & TEST DISTANCE: HORIZONTAL AT 3 M

FREQ. (MHz)	EMISSION LEVEL (dBuV/m)	READ LEVEL (dBuV)	LIMIT (dBuV/m)	MARGIN (dB)	ANTENNA FACTOR (dB/m)	CABLE LOSS (dB)	PREAMP FACTOR (dB)	ANTENNA HEIGHT (cm)	TABLE ANGLE (Degree)	REMARK
140.43	29.5	47.47	43.5	-14	12.37	1.3	31.64	115	259	Peak
186.33	28.65	48.53	43.5	-14.85	10.33	1.53	31.74	116	170	Peak
204.96	29.07	49.58	43.5	-14.43	9.56	1.62	31.69	113	312	Peak
569.5	23.04	33.22	46	-22.96	18.9	3	32.08	118	345	Peak
706	25.67	33.08	46	-20.33	20.9	3.45	31.76	112	109	Peak
778.1	27.89	33.73	46	-18.11	21.92	3.64	31.4	120	265	Peak

ANTENNA POLARITY & TEST DISTANCE: VERTICAL AT 3 M

FREQ. (MHz)	EMISSION LEVEL (dBuV/m)	READ LEVEL (dBuV)	LIMIT (dBuV/m)	MARGIN (dB)	ANTENNA FACTOR (dB/m)	CABLE LOSS (dB)	PREAMP FACTOR (dB)	ANTENNA HEIGHT (cm)	TABLE ANGLE (Degree)	REMARK
36.75	25.42	42.74	40	-14.58	13.09	0.62	31.03	111	107	Peak
86.97	27.34	49.9	40	-12.66	8.25	1.01	31.82	125	224	Peak
138.54	25.79	43.89	43.5	-17.71	12.27	1.29	31.66	100	44	Peak
596.8	24.56	34.17	46	-21.44	19.52	3.08	32.21	101	152	Peak
696.9	25.7	33.3	46	-20.3	20.78	3.42	31.8	121	261	Peak
807.5	27.54	32.95	46	-18.46	22.33	3.71	31.45	109	161	Peak

REMARKS: Emission Level = Read Level + Antenna Factor + Cable Loss - Preamp Factor
 Margin value = Emission level – Limit value



A D T

EUT TEST CONDITION		MEASUREMENT DETAIL	
CHANNEL	Channel 157	FREQUENCY RANGE	30MHz ~ 1GHz
INPUT POWER	120Vac, 60 Hz	DETECTOR FUNCTION	Peak (PK)
ENVIRONMENTAL CONDITIONS	25deg. C, 65%RH	TESTED BY	Toby Tian

ANTENNA POLARITY & TEST DISTANCE: HORIZONTAL AT 3 M										
FREQ. (MHz)	EMISSION LEVEL (dBuV/m)	READ LEVEL (dBuV)	LIMIT (dBuV/m)	MARGIN (dB)	ANTENNA FACTOR (dB/m)	CABLE LOSS (dB)	PREAMP FACTOR (dB)	ANTENNA HEIGHT (cm)	TABLE ANGLE (Degree)	REMARK
134.49	29.07	47.55	43.5	-14.43	12.01	1.27	31.76	130	132	Peak
144.75	28.01	45.81	43.5	-15.49	12.51	1.32	31.63	129	71	Peak
207.39	29	49.32	43.5	-14.5	9.69	1.63	31.64	103	238	Peak
654.9	25.04	33.5	46	-20.96	20.27	3.26	31.99	140	303	Peak
759.9	26.93	33.11	46	-19.07	21.66	3.6	31.44	114	276	Peak
787.2	27.55	33.25	46	-18.45	22.05	3.66	31.41	101	68	Peak

ANTENNA POLARITY & TEST DISTANCE: VERTICAL AT 3 M										
FREQ. (MHz)	EMISSION LEVEL (dBuV/m)	READ LEVEL (dBuV)	LIMIT (dBuV/m)	MARGIN (dB)	ANTENNA FACTOR (dB/m)	CABLE LOSS (dB)	PREAMP FACTOR (dB)	ANTENNA HEIGHT (cm)	TABLE ANGLE (Degree)	REMARK
30.81	27.82	46.23	40	-12.18	12.14	0.57	31.12	140	45	Peak
86.43	27.41	49.96	40	-12.59	8.23	1	31.78	107	254	Peak
133.14	26.17	44.84	43.5	-17.33	11.88	1.26	31.81	114	36	Peak
617.1	24.24	33.43	46	-21.76	19.81	3.14	32.14	124	16	Peak
715.8	26.45	33.62	46	-19.55	21.04	3.48	31.69	105	38	Peak
792.1	27.48	33.09	46	-18.52	22.12	3.68	31.41	108	247	Peak

REMARKS: Emission Level = Read Level + Antenna Factor + Cable Loss - Preamp Factor
Margin value = Emission level – Limit value



A D T

EUT TEST CONDITION		MEASUREMENT DETAIL	
CHANNEL	Channel 165	FREQUENCY RANGE	30MHz ~ 1GHz
INPUT POWER	120Vac, 60 Hz	DETECTOR FUNCTION	Peak (PK)
ENVIRONMENTAL CONDITIONS	25deg. C, 65%RH	TESTED BY	Toby Tian

ANTENNA POLARITY & TEST DISTANCE: HORIZONTAL AT 3 M

FREQ. (MHz)	EMISSION LEVEL (dBuV/m)	READ LEVEL (dBuV)	LIMIT (dBuV/m)	MARGIN (dB)	ANTENNA FACTOR (dB/m)	CABLE LOSS (dB)	PREAMP FACTOR (dB)	ANTENNA HEIGHT (cm)	TABLE ANGLE (Degree)	REMARK
132.87	29.49	48.16	43.5	-14.01	11.88	1.26	31.81	109	158	Peak
144.48	28.49	46.29	43.5	-15.01	12.51	1.32	31.63	137	113	Peak
203.61	29.39	49.96	43.5	-14.11	9.52	1.61	31.7	129	19	Peak
637.4	24.37	33.21	46	-21.63	20.06	3.2	32.1	106	266	Peak
751.5	26.58	32.78	46	-19.42	21.55	3.58	31.33	112	181	Peak
787.2	27.37	33.07	46	-18.63	22.05	3.66	31.41	124	73	Peak

ANTENNA POLARITY & TEST DISTANCE: VERTICAL AT 3 M

FREQ. (MHz)	EMISSION LEVEL (dBuV/m)	READ LEVEL (dBuV)	LIMIT (dBuV/m)	MARGIN (dB)	ANTENNA FACTOR (dB/m)	CABLE LOSS (dB)	PREAMP FACTOR (dB)	ANTENNA HEIGHT (cm)	TABLE ANGLE (Degree)	REMARK
30.81	27.64	46.05	40	-12.36	12.14	0.57	31.12	131	164	Peak
86.43	26.95	49.5	40	-13.05	8.23	1	31.78	132	258	Peak
138	26.17	44.37	43.5	-17.33	12.21	1.28	31.69	128	193	Peak
629.7	24.37	33.37	46	-21.63	19.96	3.18	32.14	127	70	Peak
725.6	26.99	33.93	46	-19.01	21.18	3.5	31.62	114	253	Peak
780.9	27.71	33.53	46	-18.29	21.96	3.65	31.43	109	260	Peak

REMARKS: Emission Level = Read Level + Antenna Factor + Cable Loss - Preamp Factor

Margin value = Emission level – Limit value



A D T

802.11n (20MHz)

EUT TEST CONDITION		MEASUREMENT DETAIL	
CHANNEL	Channel 36	FREQUENCY RANGE	30MHz ~ 1GHz
INPUT POWER	120Vac, 60 Hz	DETECTOR FUNCTION	Peak (PK)
ENVIRONMENTAL CONDITIONS	25deg. C, 65%RH	TESTED BY	Toby Tian

ANTENNA POLARITY & TEST DISTANCE: HORIZONTAL AT 3 M										
FREQ. (MHz)	EMISSION LEVEL (dBuV/m)	READ LEVEL (dBuV)	LIMIT (dBuV/m)	MARGIN (dB)	ANTENNA FACTOR (dB/m)	CABLE LOSS (dB)	PREAMP FACTOR (dB)	ANTENNA HEIGHT (cm)	TABLE ANGLE (Degree)	REMARK
142.86	28.98	46.86	43.5	-14.52	12.44	1.31	31.63	107	294	Peak
185.79	27.16	47.04	43.5	-16.34	10.33	1.53	31.74	106	108	Peak
208.2	27.38	47.64	43.5	-16.12	9.73	1.63	31.62	128	228	Peak
554.1	22.84	33.32	46	-23.16	18.55	2.96	31.99	112	239	Peak
624.8	24.58	33.68	46	-21.42	19.9	3.16	32.16	106	275	Peak
767.6	27.64	33.61	46	-18.36	21.76	3.61	31.34	137	213	Peak
ANTENNA POLARITY & TEST DISTANCE: VERTICAL AT 3 M										
FREQ. (MHz)	EMISSION LEVEL (dBuV/m)	READ LEVEL (dBuV)	LIMIT (dBuV/m)	MARGIN (dB)	ANTENNA FACTOR (dB/m)	CABLE LOSS (dB)	PREAMP FACTOR (dB)	ANTENNA HEIGHT (cm)	TABLE ANGLE (Degree)	REMARK
86.43	26.8	49.35	40	-13.2	8.23	1	31.78	131	145	Peak
141.24	25.04	42.96	43.5	-18.46	12.41	1.3	31.63	105	33	Peak
186.6	24.13	44.01	43.5	-19.37	10.33	1.53	31.74	106	146	Peak
688.5	25.89	33.66	46	-20.11	20.68	3.39	31.84	122	3	Peak
756.4	26.52	32.72	46	-19.48	21.61	3.59	31.4	135	86	Peak
773.9	27.32	33.18	46	-18.68	21.86	3.63	31.35	119	240	Peak

REMARKS: Emission Level = Read Level + Antenna Factor + Cable Loss - Preamp Factor

Margin value = Emission level – Limit value



A D T

EUT TEST CONDITION		MEASUREMENT DETAIL	
CHANNEL	Channel 44	FREQUENCY RANGE	30MHz ~ 1GHz
INPUT POWER	120Vac, 60 Hz	DETECTOR FUNCTION	Peak (PK)
ENVIRONMENTAL CONDITIONS	25deg. C, 65%RH	TESTED BY	Toby Tian

ANTENNA POLARITY & TEST DISTANCE: HORIZONTAL AT 3 M

FREQ. (MHz)	EMISSION LEVEL (dBuV/m)	READ LEVEL (dBuV)	LIMIT (dBuV/m)	MARGIN (dB)	ANTENNA FACTOR (dB/m)	CABLE LOSS (dB)	PREAMP FACTOR (dB)	ANTENNA HEIGHT (cm)	TABLE ANGLE (Degree)	REMARK
140.7	29.26	47.23	43.5	-14.24	12.37	1.3	31.64	104	27	Peak
187.41	28.54	48.47	43.5	-14.96	10.26	1.53	31.72	130	114	Peak
206.85	28.74	49.12	43.5	-14.76	9.65	1.63	31.66	113	22	Peak
715.8	25.56	32.73	46	-20.44	21.04	3.48	31.69	104	180	Peak
762	26.23	32.35	46	-19.77	21.7	3.6	31.42	131	328	Peak
794.2	28.58	34.16	46	-17.42	22.15	3.68	31.41	138	234	Peak

ANTENNA POLARITY & TEST DISTANCE: VERTICAL AT 3 M

FREQ. (MHz)	EMISSION LEVEL (dBuV/m)	READ LEVEL (dBuV)	LIMIT (dBuV/m)	MARGIN (dB)	ANTENNA FACTOR (dB/m)	CABLE LOSS (dB)	PREAMP FACTOR (dB)	ANTENNA HEIGHT (cm)	TABLE ANGLE (Degree)	REMARK
30.54	27.56	45.97	40	-12.44	12.14	0.57	31.12	139	133	Peak
86.43	27.2	49.75	40	-12.8	8.23	1	31.78	116	2	Peak
133.41	25.84	44.42	43.5	-17.66	11.94	1.26	31.78	123	94	Peak
624.1	25.41	34.52	46	-20.59	19.89	3.16	32.16	113	156	Peak
737.5	25.97	32.6	46	-20.03	21.34	3.54	31.51	109	51	Peak
780.9	27.21	33.03	46	-18.79	21.96	3.65	31.43	126	325	Peak

REMARKS: Emission Level = Read Level + Antenna Factor + Cable Loss - Preamp Factor
 Margin value = Emission level – Limit value



A D T

EUT TEST CONDITION		MEASUREMENT DETAIL	
CHANNEL	Channel 48	FREQUENCY RANGE	30MHz ~ 1GHz
INPUT POWER	120Vac, 60 Hz	DETECTOR FUNCTION	Peak (PK)
ENVIRONMENTAL CONDITIONS	25deg. C, 65%RH	TESTED BY	Toby Tian

ANTENNA POLARITY & TEST DISTANCE: HORIZONTAL AT 3 M										
FREQ. (MHz)	EMISSION LEVEL (dBuV/m)	READ LEVEL (dBuV)	LIMIT (dBuV/m)	MARGIN (dB)	ANTENNA FACTOR (dB/m)	CABLE LOSS (dB)	PREAMP FACTOR (dB)	ANTENNA HEIGHT (cm)	TABLE ANGLE (Degree)	REMARK
141.24	29.63	47.55	43.5	-13.87	12.41	1.3	31.63	105	93	Peak
186.87	28.52	48.45	43.5	-14.98	10.26	1.53	31.72	100	46	Peak
206.58	28.82	49.2	43.5	-14.68	9.65	1.63	31.66	110	192	Peak
606.6	23.96	33.32	46	-22.04	19.68	3.11	32.15	118	215	Peak
710.2	25.39	32.71	46	-20.61	20.96	3.46	31.74	110	239	Peak
789.3	27.49	33.14	46	-18.51	22.08	3.67	31.4	139	269	Peak
ANTENNA POLARITY & TEST DISTANCE: VERTICAL AT 3 M										
FREQ. (MHz)	EMISSION LEVEL (dBuV/m)	READ LEVEL (dBuV)	LIMIT (dBuV/m)	MARGIN (dB)	ANTENNA FACTOR (dB/m)	CABLE LOSS (dB)	PREAMP FACTOR (dB)	ANTENNA HEIGHT (cm)	TABLE ANGLE (Degree)	REMARK
86.97	27.3	49.86	40	-12.7	8.25	1.01	31.82	120	59	Peak
140.7	24.87	42.84	43.5	-18.63	12.37	1.3	31.64	103	67	Peak
187.95	23.72	43.69	43.5	-19.78	10.19	1.54	31.7	122	347	Peak
563.9	24.02	34.33	46	-21.98	18.77	2.99	32.07	110	246	Peak
661.9	26.18	34.46	46	-19.82	20.35	3.29	31.92	101	40	Peak
794.2	26.98	32.56	46	-19.02	22.15	3.68	31.41	103	50	Peak

REMARKS: Emission Level = Read Level + Antenna Factor + Cable Loss - Preamp Factor
 Margin value = Emission level – Limit value



A D T

EUT TEST CONDITION		MEASUREMENT DETAIL	
CHANNEL	Channel 52	FREQUENCY RANGE	30MHz ~ 1GHz
INPUT POWER	120Vac, 60 Hz	DETECTOR FUNCTION	Peak (PK)
ENVIRONMENTAL CONDITIONS	25deg. C, 65%RH	TESTED BY	Toby Tian

ANTENNA POLARITY & TEST DISTANCE: HORIZONTAL AT 3 M										
FREQ. (MHz)	EMISSION LEVEL (dBuV/m)	READ LEVEL (dBuV)	LIMIT (dBuV/m)	MARGIN (dB)	ANTENNA FACTOR (dB/m)	CABLE LOSS (dB)	PREAMP FACTOR (dB)	ANTENNA HEIGHT (cm)	TABLE ANGLE (Degree)	REMARK
56.46	18.7	36.89	40	-21.3	12.35	0.8	31.34	140	335	Peak
138	27.15	45.35	43.5	-16.35	12.21	1.28	31.69	110	132	Peak
201.72	25.07	45.77	43.5	-18.43	9.44	1.6	31.74	131	345	Peak
309.1	20.92	37.61	46	-25.08	13.17	2.08	31.94	106	191	Peak
449.8	20.91	33.94	46	-25.09	16.33	2.62	31.98	117	317	Peak
589.8	23.69	33.4	46	-22.31	19.37	3.06	32.14	133	206	Peak
ANTENNA POLARITY & TEST DISTANCE: VERTICAL AT 3 M										
FREQ. (MHz)	EMISSION LEVEL (dBuV/m)	READ LEVEL (dBuV)	LIMIT (dBuV/m)	MARGIN (dB)	ANTENNA FACTOR (dB/m)	CABLE LOSS (dB)	PREAMP FACTOR (dB)	ANTENNA HEIGHT (cm)	TABLE ANGLE (Degree)	REMARK
30.81	24.76	43.17	40	-15.24	12.14	0.57	31.12	122	318	Peak
68.07	23.8	43.65	40	-16.2	11	0.88	31.73	134	6	Peak
136.92	26.22	44.51	43.5	-17.28	12.14	1.28	31.71	110	116	Peak
309.1	18.56	35.25	46	-27.44	13.17	2.08	31.94	121	279	Peak
435.8	20.22	33.62	46	-25.78	16.04	2.56	32	122	80	Peak
582.8	23.4	33.28	46	-22.6	19.21	3.04	32.13	100	70	Peak

REMARKS: Emission Level = Read Level + Antenna Factor + Cable Loss - Preamp Factor

Margin value = Emission level – Limit value



A D T

EUT TEST CONDITION		MEASUREMENT DETAIL	
CHANNEL	Channel 60	FREQUENCY RANGE	30MHz ~ 1GHz
INPUT POWER	120Vac, 60 Hz	DETECTOR FUNCTION	Peak (PK)
ENVIRONMENTAL CONDITIONS	25deg. C, 65%RH	TESTED BY	Toby Tian

ANTENNA POLARITY & TEST DISTANCE: HORIZONTAL AT 3 M										
FREQ. (MHz)	EMISSION LEVEL (dBuV/m)	READ LEVEL (dBuV)	LIMIT (dBuV/m)	MARGIN (dB)	ANTENNA FACTOR (dB/m)	CABLE LOSS (dB)	PREAMP FACTOR (dB)	ANTENNA HEIGHT (cm)	TABLE ANGLE (Degree)	REMARK
42.96	19.37	36.17	40	-20.63	13.58	0.7	31.08	115	188	Peak
137.73	27.2	45.4	43.5	-16.3	12.21	1.28	31.69	109	227	Peak
192.54	24.39	44.69	43.5	-19.11	9.84	1.56	31.7	132	147	Peak
305.6	21.36	38.11	46	-24.64	13.08	2.07	31.9	133	256	Peak
414.8	20.33	34.23	46	-25.67	15.64	2.48	32.02	123	276	Peak
587.7	23.28	33.05	46	-22.72	19.32	3.05	32.14	126	12	Peak
ANTENNA POLARITY & TEST DISTANCE: VERTICAL AT 3 M										
FREQ. (MHz)	EMISSION LEVEL (dBuV/m)	READ LEVEL (dBuV)	LIMIT (dBuV/m)	MARGIN (dB)	ANTENNA FACTOR (dB/m)	CABLE LOSS (dB)	PREAMP FACTOR (dB)	ANTENNA HEIGHT (cm)	TABLE ANGLE (Degree)	REMARK
30.54	24.62	43.03	40	-15.38	12.14	0.57	31.12	128	138	Peak
85.08	23.14	45.66	40	-16.86	8.22	1	31.74	118	216	Peak
138.54	26.51	44.61	43.5	-16.99	12.27	1.29	31.66	101	354	Peak
309.8	18.34	35.03	46	-27.66	13.17	2.08	31.94	128	207	Peak
433.7	20.36	33.82	46	-25.64	16	2.55	32.01	125	29	Peak
563.9	23.69	34	46	-22.31	18.77	2.99	32.07	109	327	Peak

REMARKS: Emission Level = Read Level + Antenna Factor + Cable Loss - Preamp Factor

Margin value = Emission level – Limit value



A D T

EUT TEST CONDITION		MEASUREMENT DETAIL	
CHANNEL	Channel 64	FREQUENCY RANGE	30MHz ~ 1GHz
INPUT POWER	120Vac, 60 Hz	DETECTOR FUNCTION	Peak (PK)
ENVIRONMENTAL CONDITIONS	25deg. C, 65%RH	TESTED BY	Toby Tian

ANTENNA POLARITY & TEST DISTANCE: HORIZONTAL AT 3 M										
FREQ. (MHz)	EMISSION LEVEL (dBuV/m)	READ LEVEL (dBuV)	LIMIT (dBuV/m)	MARGIN (dB)	ANTENNA FACTOR (dB/m)	CABLE LOSS (dB)	PREAMP FACTOR (dB)	ANTENNA HEIGHT (cm)	TABLE ANGLE (Degree)	REMARK
43.23	19.02	35.83	40	-20.98	13.59	0.71	31.11	108	125	Peak
137.19	27.36	45.56	43.5	-16.14	12.21	1.28	31.69	116	330	Peak
201.45	25.18	45.88	43.5	-18.32	9.44	1.6	31.74	135	187	Peak
303.5	20.84	37.63	46	-25.16	13.03	2.06	31.88	127	244	Peak
447	21.06	34.17	46	-24.94	16.27	2.61	31.99	121	306	Peak
566	23.35	33.59	46	-22.65	18.84	2.99	32.07	107	282	Peak

ANTENNA POLARITY & TEST DISTANCE: VERTICAL AT 3 M										
FREQ. (MHz)	EMISSION LEVEL (dBuV/m)	READ LEVEL (dBuV)	LIMIT (dBuV/m)	MARGIN (dB)	ANTENNA FACTOR (dB/m)	CABLE LOSS (dB)	PREAMP FACTOR (dB)	ANTENNA HEIGHT (cm)	TABLE ANGLE (Degree)	REMARK
30.54	24.42	42.83	40	-15.58	12.14	0.57	31.12	132	257	Peak
87.24	23.8	46.36	40	-16.2	8.25	1.01	31.82	129	319	Peak
138	26.06	44.26	43.5	-17.44	12.21	1.28	31.69	106	247	Peak
351.1	18.16	33.61	46	-27.84	14.17	2.23	31.85	115	207	Peak
479.2	22.07	34.3	46	-23.93	16.91	2.71	31.85	114	153	Peak
589.8	24.06	33.77	46	-21.94	19.37	3.06	32.14	124	319	Peak

REMARKS: Emission Level = Read Level + Antenna Factor + Cable Loss - Preamp Factor
Margin value = Emission level – Limit value



A D T

EUT TEST CONDITION		MEASUREMENT DETAIL	
CHANNEL	Channel 100	FREQUENCY RANGE	30MHz ~ 1GHz
INPUT POWER	120Vac, 60 Hz	DETECTOR FUNCTION	Peak (PK)
ENVIRONMENTAL CONDITIONS	25deg. C, 65%RH	TESTED BY	Toby Tian

ANTENNA POLARITY & TEST DISTANCE: HORIZONTAL AT 3 M										
FREQ. (MHz)	EMISSION LEVEL (dBuV/m)	READ LEVEL (dBuV)	LIMIT (dBuV/m)	MARGIN (dB)	ANTENNA FACTOR (dB/m)	CABLE LOSS (dB)	PREAMP FACTOR (dB)	ANTENNA HEIGHT (cm)	TABLE ANGLE (Degree)	REMARK
56.73	19.92	38.21	40	-20.08	12.25	0.81	31.35	132	66	Peak
138.81	28.01	46.11	43.5	-15.49	12.27	1.29	31.66	117	173	Peak
200.37	25.36	46.11	43.5	-18.14	9.4	1.6	31.75	121	117	Peak
303.5	20.73	37.52	46	-25.27	13.03	2.06	31.88	135	203	Peak
436.5	21.02	34.4	46	-24.98	16.06	2.56	32	129	176	Peak
560.4	22.72	33.1	46	-23.28	18.7	2.98	32.06	134	225	Peak

ANTENNA POLARITY & TEST DISTANCE: VERTICAL AT 3 M										
FREQ. (MHz)	EMISSION LEVEL (dBuV/m)	READ LEVEL (dBuV)	LIMIT (dBuV/m)	MARGIN (dB)	ANTENNA FACTOR (dB/m)	CABLE LOSS (dB)	PREAMP FACTOR (dB)	ANTENNA HEIGHT (cm)	TABLE ANGLE (Degree)	REMARK
30.27	24	42.59	40	-16	11.98	0.57	31.14	108	1	Peak
68.07	24.6	44.45	40	-15.4	11	0.88	31.73	127	112	Peak
136.65	26.86	45.15	43.5	-16.64	12.14	1.28	31.71	134	56	Peak
321.7	17.95	34.22	46	-28.05	13.47	2.13	31.87	111	300	Peak
395.2	19.45	33.92	46	-26.55	15.21	2.4	32.08	140	161	Peak
555.5	22.98	33.45	46	-23.02	18.59	2.96	32.02	132	72	Peak

REMARKS: Emission Level = Read Level + Antenna Factor + Cable Loss - Preamp Factor
 Margin value = Emission level – Limit value



A D T

EUT TEST CONDITION		MEASUREMENT DETAIL	
CHANNEL	Channel 116	FREQUENCY RANGE	30MHz ~ 1GHz
INPUT POWER	120Vac, 60 Hz	DETECTOR FUNCTION	Peak (PK)
ENVIRONMENTAL CONDITIONS	25deg. C, 65%RH	TESTED BY	Toby Tian

ANTENNA POLARITY & TEST DISTANCE: HORIZONTAL AT 3 M										
FREQ. (MHz)	EMISSION LEVEL (dBuV/m)	READ LEVEL (dBuV)	LIMIT (dBuV/m)	MARGIN (dB)	ANTENNA FACTOR (dB/m)	CABLE LOSS (dB)	PREAMP FACTOR (dB)	ANTENNA HEIGHT (cm)	TABLE ANGLE (Degree)	REMARK
43.77	18.74	35.55	40	-21.26	13.59	0.71	31.11	103	239	Peak
137.73	28	46.2	43.5	-15.5	12.21	1.28	31.69	126	57	Peak
199.56	25.07	45.89	43.5	-18.43	9.36	1.59	31.77	133	244	Peak
302.8	20.89	37.69	46	-25.11	13.01	2.06	31.87	119	198	Peak
372.8	19.8	34.73	46	-26.2	14.68	2.32	31.93	108	105	Peak
566.7	22.61	32.85	46	-23.39	18.84	2.99	32.07	119	28	Peak
ANTENNA POLARITY & TEST DISTANCE: VERTICAL AT 3 M										
FREQ. (MHz)	EMISSION LEVEL (dBuV/m)	READ LEVEL (dBuV)	LIMIT (dBuV/m)	MARGIN (dB)	ANTENNA FACTOR (dB/m)	CABLE LOSS (dB)	PREAMP FACTOR (dB)	ANTENNA HEIGHT (cm)	TABLE ANGLE (Degree)	REMARK
30.81	24.35	42.76	40	-15.65	12.14	0.57	31.12	120	143	Peak
67.8	24.53	44.38	40	-15.47	11	0.88	31.73	104	117	Peak
138.54	26.77	44.87	43.5	-16.73	12.27	1.29	31.66	110	10	Peak
326.6	18.23	34.32	46	-27.77	13.59	2.15	31.83	139	354	Peak
436.5	20.1	33.48	46	-25.9	16.06	2.56	32	101	210	Peak
554.1	23.05	33.53	46	-22.95	18.55	2.96	31.99	110	233	Peak

REMARKS: Emission Level = Read Level + Antenna Factor + Cable Loss - Preamp Factor

Margin value = Emission level – Limit value



A D T

EUT TEST CONDITION		MEASUREMENT DETAIL	
CHANNEL	Channel 120	FREQUENCY RANGE	30MHz ~ 1GHz
INPUT POWER	120Vac, 60 Hz	DETECTOR FUNCTION	Peak (PK)
ENVIRONMENTAL CONDITIONS	25deg. C, 65%RH	TESTED BY	Toby Tian

ANTENNA POLARITY & TEST DISTANCE: HORIZONTAL AT 3 M										
FREQ. (MHz)	EMISSION LEVEL (dBuV/m)	READ LEVEL (dBuV)	LIMIT (dBuV/m)	MARGIN (dB)	ANTENNA FACTOR (dB/m)	CABLE LOSS (dB)	PREAMP FACTOR (dB)	ANTENNA HEIGHT (cm)	TABLE ANGLE (Degree)	REMARK
42.96	17.53	34.33	40	-22.47	13.58	0.7	31.08	117	316	Peak
134.76	25.81	44.29	43.5	-17.69	12.01	1.27	31.76	112	116	Peak
194.16	23.34	43.72	43.5	-20.16	9.77	1.56	31.71	117	246	Peak
307.7	19.65	36.36	46	-26.35	13.13	2.08	31.92	140	228	Peak
488.3	19.99	31.96	46	-26.01	17.08	2.74	31.79	102	315	Peak
597.5	22.31	31.91	46	-23.69	19.54	3.08	32.22	122	17	Peak

ANTENNA POLARITY & TEST DISTANCE: VERTICAL AT 3 M										
FREQ. (MHz)	EMISSION LEVEL (dBuV/m)	READ LEVEL (dBuV)	LIMIT (dBuV/m)	MARGIN (dB)	ANTENNA FACTOR (dB/m)	CABLE LOSS (dB)	PREAMP FACTOR (dB)	ANTENNA HEIGHT (cm)	TABLE ANGLE (Degree)	REMARK
37.56	21.96	39.11	40	-18.04	13.24	0.63	31.02	101	113	Peak
86.97	22.61	45.17	40	-17.39	8.25	1.01	31.82	128	121	Peak
135.84	24.74	43.13	43.5	-18.76	12.08	1.27	31.74	114	321	Peak
380.5	18.02	32.75	46	-27.98	14.87	2.35	31.95	108	325	Peak
486.9	20.72	32.71	46	-25.28	17.06	2.74	31.79	139	102	Peak
607.3	23.26	32.59	46	-22.74	19.69	3.11	32.13	137	175	Peak

REMARKS: Emission Level = Read Level + Antenna Factor + Cable Loss - Preamp Factor
 Margin value = Emission level – Limit value



A D T

EUT TEST CONDITION		MEASUREMENT DETAIL	
CHANNEL	Channel 140	FREQUENCY RANGE	30MHz ~ 1GHz
INPUT POWER	120Vac, 60 Hz	DETECTOR FUNCTION	Peak (PK)
ENVIRONMENTAL CONDITIONS	25deg. C, 65%RH	TESTED BY	Toby Tian

ANTENNA POLARITY & TEST DISTANCE: HORIZONTAL AT 3 M										
FREQ. (MHz)	EMISSION LEVEL (dBuV/m)	READ LEVEL (dBuV)	LIMIT (dBuV/m)	MARGIN (dB)	ANTENNA FACTOR (dB/m)	CABLE LOSS (dB)	PREAMP FACTOR (dB)	ANTENNA HEIGHT (cm)	TABLE ANGLE (Degree)	REMARK
56.73	18.77	37.06	40	-21.23	12.25	0.81	31.35	134	231	Peak
138.54	27.51	45.61	43.5	-15.99	12.27	1.29	31.66	108	238	Peak
194.7	24.81	45.26	43.5	-18.69	9.7	1.57	31.72	108	235	Peak
304.2	21.28	38.04	46	-24.72	13.06	2.07	31.89	105	305	Peak
419	20.32	34.15	46	-25.68	15.71	2.5	32.04	129	120	Peak
509.3	22.52	33.77	46	-23.48	17.53	2.81	31.59	121	340	Peak
ANTENNA POLARITY & TEST DISTANCE: VERTICAL AT 3 M										
FREQ. (MHz)	EMISSION LEVEL (dBuV/m)	READ LEVEL (dBuV)	LIMIT (dBuV/m)	MARGIN (dB)	ANTENNA FACTOR (dB/m)	CABLE LOSS (dB)	PREAMP FACTOR (dB)	ANTENNA HEIGHT (cm)	TABLE ANGLE (Degree)	REMARK
30.81	24.18	42.59	40	-15.82	12.14	0.57	31.12	139	13	Peak
68.88	24.01	44	40	-15.99	10.89	0.89	31.77	101	29	Peak
139.35	26.14	44.15	43.5	-17.36	12.34	1.29	31.64	104	19	Peak
372.8	19.96	34.89	46	-26.04	14.68	2.32	31.93	113	36	Peak
500.2	23.84	35.35	46	-22.16	17.33	2.78	31.62	105	50	Peak
592.6	26.15	35.82	46	-19.85	19.43	3.07	32.17	103	147	Peak

REMARKS: Emission Level = Read Level + Antenna Factor + Cable Loss - Preamp Factor

Margin value = Emission level – Limit value



A D T

EUT TEST CONDITION		MEASUREMENT DETAIL	
CHANNEL	Channel 149	FREQUENCY RANGE	30MHz ~ 1GHz
INPUT POWER	120Vac, 60 Hz	DETECTOR FUNCTION	Peak (PK)
ENVIRONMENTAL CONDITIONS	25deg. C, 65%RH	TESTED BY	Toby Tian

ANTENNA POLARITY & TEST DISTANCE: HORIZONTAL AT 3 M										
FREQ. (MHz)	EMISSION LEVEL (dBuV/m)	READ LEVEL (dBuV)	LIMIT (dBuV/m)	MARGIN (dB)	ANTENNA FACTOR (dB/m)	CABLE LOSS (dB)	PREAMP FACTOR (dB)	ANTENNA HEIGHT (cm)	TABLE ANGLE (Degree)	REMARK
145.02	27.57	45.33	43.5	-15.93	12.54	1.32	31.62	103	74	Peak
189.03	28.37	48.4	43.5	-15.13	10.12	1.54	31.69	113	154	Peak
204.42	29.52	50.03	43.5	-13.98	9.56	1.62	31.69	125	46	Peak
671	24.67	32.69	46	-21.33	20.47	3.32	31.81	129	102	Peak
757.8	26.49	32.68	46	-19.51	21.63	3.59	31.41	111	323	Peak
772.5	27.41	33.28	46	-18.59	21.83	3.63	31.33	101	327	Peak

ANTENNA POLARITY & TEST DISTANCE: VERTICAL AT 3 M										
FREQ. (MHz)	EMISSION LEVEL (dBuV/m)	READ LEVEL (dBuV)	LIMIT (dBuV/m)	MARGIN (dB)	ANTENNA FACTOR (dB/m)	CABLE LOSS (dB)	PREAMP FACTOR (dB)	ANTENNA HEIGHT (cm)	TABLE ANGLE (Degree)	REMARK
30.81	27.44	45.85	40	-12.56	12.14	0.57	31.12	122	216	Peak
83.73	27.8	50.28	40	-12.2	8.18	0.99	31.65	107	22	Peak
133.14	25.68	44.35	43.5	-17.82	11.88	1.26	31.81	100	150	Peak
678	25.05	32.98	46	-20.95	20.55	3.35	31.83	131	17	Peak
722.1	26.14	33.15	46	-19.86	21.13	3.5	31.64	118	86	Peak
778.1	27	32.84	46	-19	21.92	3.64	31.4	113	41	Peak

REMARKS: Emission Level = Read Level + Antenna Factor + Cable Loss - Preamp Factor
 Margin value = Emission level – Limit value



A D T

EUT TEST CONDITION		MEASUREMENT DETAIL	
CHANNEL	Channel 157	FREQUENCY RANGE	30MHz ~ 1GHz
INPUT POWER	120Vac, 60 Hz	DETECTOR FUNCTION	Peak (PK)
ENVIRONMENTAL CONDITIONS	25deg. C, 65%RH	TESTED BY	Toby Tian

ANTENNA POLARITY & TEST DISTANCE: HORIZONTAL AT 3 M										
FREQ. (MHz)	EMISSION LEVEL (dBuV/m)	READ LEVEL (dBuV)	LIMIT (dBuV/m)	MARGIN (dB)	ANTENNA FACTOR (dB/m)	CABLE LOSS (dB)	PREAMP FACTOR (dB)	ANTENNA HEIGHT (cm)	TABLE ANGLE (Degree)	REMARK
133.68	28.74	47.32	43.5	-14.76	11.94	1.26	31.78	129	14	Peak
141.24	29.59	47.51	43.5	-13.91	12.41	1.3	31.63	122	49	Peak
203.34	29.74	50.31	43.5	-13.76	9.52	1.61	31.7	104	158	Peak
633.9	25.06	33.97	46	-20.94	20.02	3.19	32.12	121	6	Peak
748.7	27.56	33.81	46	-18.44	21.5	3.57	31.32	100	229	Peak
799.1	27.75	33.27	46	-18.25	22.22	3.69	31.43	105	338	Peak

ANTENNA POLARITY & TEST DISTANCE: VERTICAL AT 3 M										
FREQ. (MHz)	EMISSION LEVEL (dBuV/m)	READ LEVEL (dBuV)	LIMIT (dBuV/m)	MARGIN (dB)	ANTENNA FACTOR (dB/m)	CABLE LOSS (dB)	PREAMP FACTOR (dB)	ANTENNA HEIGHT (cm)	TABLE ANGLE (Degree)	REMARK
30.81	27.15	45.56	40	-12.85	12.14	0.57	31.12	102	191	Peak
84	27.95	50.45	40	-12.05	8.2	0.99	31.69	131	2	Peak
132.87	25.76	44.43	43.5	-17.74	11.88	1.26	31.81	139	356	Peak
631.1	24.31	33.27	46	-21.69	19.99	3.18	32.13	110	324	Peak
715.8	25.44	32.61	46	-20.56	21.04	3.48	31.69	135	136	Peak
759.9	26.56	32.74	46	-19.44	21.66	3.6	31.44	125	68	Peak

REMARKS: Emission Level = Read Level + Antenna Factor + Cable Loss - Preamp Factor
Margin value = Emission level – Limit value



A D T

EUT TEST CONDITION		MEASUREMENT DETAIL	
CHANNEL	Channel 165	FREQUENCY RANGE	30MHz ~ 1GHz
INPUT POWER	120Vac, 60 Hz	DETECTOR FUNCTION	Peak (PK)
ENVIRONMENTAL CONDITIONS	25deg. C, 65%RH	TESTED BY	Toby Tian

ANTENNA POLARITY & TEST DISTANCE: HORIZONTAL AT 3 M										
FREQ. (MHz)	EMISSION LEVEL (dBuV/m)	READ LEVEL (dBuV)	LIMIT (dBuV/m)	MARGIN (dB)	ANTENNA FACTOR (dB/m)	CABLE LOSS (dB)	PREAMP FACTOR (dB)	ANTENNA HEIGHT (cm)	TABLE ANGLE (Degree)	REMARK
140.97	29.47	47.44	43.5	-14.03	12.37	1.3	31.64	111	10	Peak
186.6	28.96	48.84	43.5	-14.54	10.33	1.53	31.74	128	132	Peak
204.42	29.49	50	43.5	-14.01	9.56	1.62	31.69	124	47	Peak
692.7	25.75	33.45	46	-20.25	20.73	3.4	31.83	131	289	Peak
748.7	26.98	33.23	46	-19.02	21.5	3.57	31.32	123	98	Peak
793.5	27.81	33.41	46	-18.19	22.13	3.68	31.41	134	224	Peak

ANTENNA POLARITY & TEST DISTANCE: VERTICAL AT 3 M										
FREQ. (MHz)	EMISSION LEVEL (dBuV/m)	READ LEVEL (dBuV)	LIMIT (dBuV/m)	MARGIN (dB)	ANTENNA FACTOR (dB/m)	CABLE LOSS (dB)	PREAMP FACTOR (dB)	ANTENNA HEIGHT (cm)	TABLE ANGLE (Degree)	REMARK
31.08	27.65	46.06	40	-12.35	12.14	0.57	31.12	137	144	Peak
86.43	27.82	50.37	40	-12.18	8.23	1	31.78	108	198	Peak
133.68	26.05	44.63	43.5	-17.45	11.94	1.26	31.78	124	340	Peak
584.9	24.73	34.56	46	-21.27	19.26	3.04	32.13	105	266	Peak
687.1	25.28	33.08	46	-20.72	20.66	3.38	31.84	100	265	Peak
766.2	28.32	34.32	46	-17.68	21.75	3.61	31.36	100	140	Peak

REMARKS: Emission Level = Read Level + Antenna Factor + Cable Loss - Preamp Factor
 Margin value = Emission level – Limit value



A D T

Mode B

802.11a

EUT TEST CONDITION		MEASUREMENT DETAIL	
CHANNEL	Channel 36	FREQUENCY RANGE	30MHz ~ 1GHz
INPUT POWER	120Vac, 60 Hz	DETECTOR FUNCTION	Peak (PK)
ENVIRONMENTAL CONDITIONS	25deg. C, 65%RH	TESTED BY	Toby Tian

ANTENNA POLARITY & TEST DISTANCE: HORIZONTAL AT 3 M

FREQ. (MHz)	EMISSION LEVEL (dBuV/m)	READ LEVEL (dBuV)	LIMIT (dBuV/m)	MARGIN (dB)	ANTENNA FACTOR (dB/m)	CABLE LOSS (dB)	PREAMP FACTOR (dB)	ANTENNA HEIGHT (cm)	TABLE ANGLE (Degree)	REMARK
138.27	28.97	47.07	43.5	-14.53	12.27	1.29	31.66	118	108	Peak
188.76	27.01	47.04	43.5	-16.49	10.12	1.54	31.69	118	328	Peak
204.96	28.99	49.5	43.5	-14.51	9.56	1.62	31.69	135	261	Peak
650	23.73	32.3	46	-22.27	20.21	3.24	32.02	131	175	Peak
679.4	23.78	31.71	46	-22.22	20.56	3.35	31.84	133	232	Peak
757.8	25.65	31.84	46	-20.35	21.63	3.59	31.41	138	341	Peak

ANTENNA POLARITY & TEST DISTANCE: VERTICAL AT 3 M

FREQ. (MHz)	EMISSION LEVEL (dBuV/m)	READ LEVEL (dBuV)	LIMIT (dBuV/m)	MARGIN (dB)	ANTENNA FACTOR (dB/m)	CABLE LOSS (dB)	PREAMP FACTOR (dB)	ANTENNA HEIGHT (cm)	TABLE ANGLE (Degree)	REMARK
86.97	25.01	47.57	40	-14.99	8.25	1.01	31.82	138	182	Peak
134.49	25.57	44.05	43.5	-17.93	12.01	1.27	31.76	133	198	Peak
138.27	25.35	43.45	43.5	-18.15	12.27	1.29	31.66	128	232	Peak
676.6	24	31.95	46	-22	20.54	3.34	31.83	122	228	Peak
725.6	24.67	31.61	46	-21.33	21.18	3.5	31.62	132	268	Peak
766.2	26.27	32.27	46	-19.73	21.75	3.61	31.36	139	165	Peak

REMARKS: Emission Level = Read Level + Antenna Factor + Cable Loss - Preamp Factor

Margin value = Emission level – Limit value



A D T

EUT TEST CONDITION		MEASUREMENT DETAIL	
CHANNEL	Channel 44	FREQUENCY RANGE	30MHz ~ 1GHz
INPUT POWER	120Vac, 60 Hz	DETECTOR FUNCTION	Peak (PK)
ENVIRONMENTAL CONDITIONS	25deg. C, 65%RH	TESTED BY	Toby Tian

ANTENNA POLARITY & TEST DISTANCE: HORIZONTAL AT 3 M										
FREQ. (MHz)	EMISSION LEVEL (dBuV/m)	READ LEVEL (dBuV)	LIMIT (dBuV/m)	MARGIN (dB)	ANTENNA FACTOR (dB/m)	CABLE LOSS (dB)	PREAMP FACTOR (dB)	ANTENNA HEIGHT (cm)	TABLE ANGLE (Degree)	REMARK
141.51	29.18	47.1	43.5	-14.32	12.41	1.3	31.63	100	154	Peak
184.44	26.45	46.24	43.5	-17.05	10.46	1.52	31.77	105	242	Peak
202.8	28.59	49.22	43.5	-14.91	9.48	1.61	31.72	128	257	Peak
681.5	24.58	32.46	46	-21.42	20.6	3.36	31.84	135	227	Peak
742.4	26.06	32.54	46	-19.94	21.41	3.55	31.44	100	134	Peak
777.4	26.08	31.92	46	-19.92	21.92	3.64	31.4	108	135	Peak

ANTENNA POLARITY & TEST DISTANCE: VERTICAL AT 3 M										
FREQ. (MHz)	EMISSION LEVEL (dBuV/m)	READ LEVEL (dBuV)	LIMIT (dBuV/m)	MARGIN (dB)	ANTENNA FACTOR (dB/m)	CABLE LOSS (dB)	PREAMP FACTOR (dB)	ANTENNA HEIGHT (cm)	TABLE ANGLE (Degree)	REMARK
81.84	25.62	48.05	40	-14.38	8.15	0.98	31.56	119	323	Peak
86.97	24.19	46.75	40	-15.81	8.25	1.01	31.82	124	23	Peak
136.92	25.04	43.33	43.5	-18.46	12.14	1.28	31.71	140	92	Peak
666.1	24.01	32.16	46	-21.99	20.41	3.3	31.86	127	216	Peak
717.2	24.65	31.8	46	-21.35	21.05	3.48	31.68	101	269	Peak
780.9	27.28	33.1	46	-18.72	21.96	3.65	31.43	127	305	Peak

REMARKS: Emission Level = Read Level + Antenna Factor + Cable Loss - Preamp Factor
 Margin value = Emission level – Limit value



A D T

EUT TEST CONDITION		MEASUREMENT DETAIL	
CHANNEL	Channel 48	FREQUENCY RANGE	30MHz ~ 1GHz
INPUT POWER	120Vac, 60 Hz	DETECTOR FUNCTION	Peak (PK)
ENVIRONMENTAL CONDITIONS	25deg. C, 65%RH	TESTED BY	Toby Tian

ANTENNA POLARITY & TEST DISTANCE: HORIZONTAL AT 3 M										
FREQ. (MHz)	EMISSION LEVEL (dBuV/m)	READ LEVEL (dBuV)	LIMIT (dBuV/m)	MARGIN (dB)	ANTENNA FACTOR (dB/m)	CABLE LOSS (dB)	PREAMP FACTOR (dB)	ANTENNA HEIGHT (cm)	TABLE ANGLE (Degree)	REMARK
135.03	28.96	47.44	43.5	-14.54	12.01	1.27	31.76	128	47	Peak
143.94	28.73	46.58	43.5	-14.77	12.47	1.31	31.63	138	15	Peak
204.96	29.21	49.72	43.5	-14.29	9.56	1.62	31.69	119	18	Peak
654.9	24.28	32.74	46	-21.72	20.27	3.26	31.99	136	288	Peak
713.7	23.56	30.79	46	-22.44	21.01	3.47	31.71	129	93	Peak
778.8	26.33	32.18	46	-19.67	21.93	3.64	31.42	126	196	Peak

ANTENNA POLARITY & TEST DISTANCE: VERTICAL AT 3 M										
FREQ. (MHz)	EMISSION LEVEL (dBuV/m)	READ LEVEL (dBuV)	LIMIT (dBuV/m)	MARGIN (dB)	ANTENNA FACTOR (dB/m)	CABLE LOSS (dB)	PREAMP FACTOR (dB)	ANTENNA HEIGHT (cm)	TABLE ANGLE (Degree)	REMARK
81.84	26.85	49.28	40	-13.15	8.15	0.98	31.56	112	350	Peak
128.01	23.38	42.48	43.5	-20.12	11.55	1.23	31.88	115	114	Peak
144.75	22.77	40.57	43.5	-20.73	12.51	1.32	31.63	127	204	Peak
575.1	22.05	32.1	46	-23.95	19.03	3.02	32.1	135	282	Peak
645.8	23.29	31.95	46	-22.71	20.16	3.23	32.05	107	25	Peak
762	26.22	32.34	46	-19.78	21.7	3.6	31.42	100	177	Peak

REMARKS: Emission Level = Read Level + Antenna Factor + Cable Loss - Preamp Factor
Margin value = Emission level – Limit value



A D T

EUT TEST CONDITION		MEASUREMENT DETAIL	
CHANNEL	Channel 52	FREQUENCY RANGE	30MHz ~ 1GHz
INPUT POWER	120Vac, 60 Hz	DETECTOR FUNCTION	Peak (PK)
ENVIRONMENTAL CONDITIONS	25deg. C, 65%RH	TESTED BY	Toby Tian

ANTENNA POLARITY & TEST DISTANCE: HORIZONTAL AT 3 M										
FREQ. (MHz)	EMISSION LEVEL (dBuV/m)	READ LEVEL (dBuV)	LIMIT (dBuV/m)	MARGIN (dB)	ANTENNA FACTOR (dB/m)	CABLE LOSS (dB)	PREAMP FACTOR (dB)	ANTENNA HEIGHT (cm)	TABLE ANGLE (Degree)	REMARK
43.77	18.9	35.71	40	-21.1	13.59	0.71	31.11	107	294	Peak
143.4	28.39	46.24	43.5	-15.11	12.47	1.31	31.63	124	182	Peak
200.37	25.46	46.21	43.5	-18.04	9.4	1.6	31.75	122	162	Peak
303.5	21.48	38.27	46	-24.52	13.03	2.06	31.88	127	14	Peak
500.9	21.3	32.81	46	-24.7	17.33	2.78	31.62	127	177	Peak
594.7	23.43	33.07	46	-22.57	19.48	3.07	32.19	124	345	Peak
ANTENNA POLARITY & TEST DISTANCE: VERTICAL AT 3 M										
FREQ. (MHz)	EMISSION LEVEL (dBuV/m)	READ LEVEL (dBuV)	LIMIT (dBuV/m)	MARGIN (dB)	ANTENNA FACTOR (dB/m)	CABLE LOSS (dB)	PREAMP FACTOR (dB)	ANTENNA HEIGHT (cm)	TABLE ANGLE (Degree)	REMARK
30.81	24.93	43.34	40	-15.07	12.14	0.57	31.12	134	39	Peak
87.51	23.96	46.52	40	-16.04	8.25	1.01	31.82	100	18	Peak
135.84	26.37	44.76	43.5	-17.13	12.08	1.27	31.74	103	244	Peak
300	20.53	37.38	46	-25.47	12.94	2.05	31.84	118	126	Peak
479.2	21.76	33.99	46	-24.24	16.91	2.71	31.85	105	309	Peak
592.6	27.64	37.31	46	-18.36	19.43	3.07	32.17	102	354	Peak

REMARKS: Emission Level = Read Level + Antenna Factor + Cable Loss - Preamp Factor
Margin value = Emission level – Limit value



A D T

EUT TEST CONDITION		MEASUREMENT DETAIL	
CHANNEL	Channel 60	FREQUENCY RANGE	30MHz ~ 1GHz
INPUT POWER	120Vac, 60 Hz	DETECTOR FUNCTION	Peak (PK)
ENVIRONMENTAL CONDITIONS	25deg. C, 65%RH	TESTED BY	Toby Tian

ANTENNA POLARITY & TEST DISTANCE: HORIZONTAL AT 3 M										
FREQ. (MHz)	EMISSION LEVEL (dBuV/m)	READ LEVEL (dBuV)	LIMIT (dBuV/m)	MARGIN (dB)	ANTENNA FACTOR (dB/m)	CABLE LOSS (dB)	PREAMP FACTOR (dB)	ANTENNA HEIGHT (cm)	TABLE ANGLE (Degree)	REMARK
43.5	20.06	36.87	40	-19.94	13.59	0.71	31.11	129	226	Peak
144.75	29.14	46.94	43.5	-14.36	12.51	1.32	31.63	122	99	Peak
203.34	25.71	46.28	43.5	-17.79	9.52	1.61	31.7	134	270	Peak
300	21.1	37.95	46	-24.9	12.94	2.05	31.84	120	273	Peak
457.5	20.6	33.47	46	-25.4	16.48	2.64	31.99	103	304	Peak
589.8	24.17	33.88	46	-21.83	19.37	3.06	32.14	116	176	Peak
ANTENNA POLARITY & TEST DISTANCE: VERTICAL AT 3 M										
FREQ. (MHz)	EMISSION LEVEL (dBuV/m)	READ LEVEL (dBuV)	LIMIT (dBuV/m)	MARGIN (dB)	ANTENNA FACTOR (dB/m)	CABLE LOSS (dB)	PREAMP FACTOR (dB)	ANTENNA HEIGHT (cm)	TABLE ANGLE (Degree)	REMARK
30.54	24.6	43.01	40	-15.4	12.14	0.57	31.12	104	227	Peak
87.24	23.88	46.44	40	-16.12	8.25	1.01	31.82	137	39	Peak
133.95	26.03	44.61	43.5	-17.47	11.94	1.26	31.78	131	305	Peak
310.5	19.69	36.35	46	-26.31	13.2	2.09	31.95	131	103	Peak
465.9	20.96	33.59	46	-25.04	16.64	2.67	31.94	124	148	Peak
596.1	23.71	33.32	46	-22.29	19.52	3.08	32.21	138	258	Peak

REMARKS: Emission Level = Read Level + Antenna Factor + Cable Loss - Preamp Factor
Margin value = Emission level – Limit value



A D T

EUT TEST CONDITION		MEASUREMENT DETAIL	
CHANNEL	Channel 64	FREQUENCY RANGE	30MHz ~ 1GHz
INPUT POWER	120Vac, 60 Hz	DETECTOR FUNCTION	Peak (PK)
ENVIRONMENTAL CONDITIONS	25deg. C, 65%RH	TESTED BY	Toby Tian

ANTENNA POLARITY & TEST DISTANCE: HORIZONTAL AT 3 M										
FREQ. (MHz)	EMISSION LEVEL (dBuV/m)	READ LEVEL (dBuV)	LIMIT (dBuV/m)	MARGIN (dB)	ANTENNA FACTOR (dB/m)	CABLE LOSS (dB)	PREAMP FACTOR (dB)	ANTENNA HEIGHT (cm)	TABLE ANGLE (Degree)	REMARK
55.92	19.14	37.33	40	-20.86	12.35	0.8	31.34	119	307	Peak
145.83	28.92	46.68	43.5	-14.58	12.54	1.32	31.62	108	184	Peak
191.73	24.55	44.77	43.5	-18.95	9.91	1.56	31.69	137	126	Peak
302.1	21.3	38.1	46	-24.7	13.01	2.06	31.87	120	268	Peak
457.5	22.43	35.3	46	-23.57	16.48	2.64	31.99	136	334	Peak
622	24.75	33.89	46	-21.25	19.87	3.15	32.16	108	245	Peak
ANTENNA POLARITY & TEST DISTANCE: VERTICAL AT 3 M										
FREQ. (MHz)	EMISSION LEVEL (dBuV/m)	READ LEVEL (dBuV)	LIMIT (dBuV/m)	MARGIN (dB)	ANTENNA FACTOR (dB/m)	CABLE LOSS (dB)	PREAMP FACTOR (dB)	ANTENNA HEIGHT (cm)	TABLE ANGLE (Degree)	REMARK
31.08	23.38	41.79	40	-16.62	12.14	0.57	31.12	123	134	Peak
87.24	23.81	46.37	40	-16.19	8.25	1.01	31.82	117	71	Peak
133.95	26.6	45.18	43.5	-16.9	11.94	1.26	31.78	114	248	Peak
348.3	18.66	34.18	46	-27.34	14.1	2.22	31.84	127	22	Peak
457.5	22.02	34.89	46	-23.98	16.48	2.64	31.99	113	198	Peak
563.9	24.12	34.43	46	-21.88	18.77	2.99	32.07	122	87	Peak

REMARKS: Emission Level = Read Level + Antenna Factor + Cable Loss - Preamp Factor
 Margin value = Emission level – Limit value



A D T

EUT TEST CONDITION		MEASUREMENT DETAIL	
CHANNEL	Channel 100	FREQUENCY RANGE	30MHz ~ 1GHz
INPUT POWER	120Vac, 60 Hz	DETECTOR FUNCTION	Peak (PK)
ENVIRONMENTAL CONDITIONS	25deg. C, 65%RH	TESTED BY	Toby Tian

ANTENNA POLARITY & TEST DISTANCE: HORIZONTAL AT 3 M										
FREQ. (MHz)	EMISSION LEVEL (dBuV/m)	READ LEVEL (dBuV)	LIMIT (dBuV/m)	MARGIN (dB)	ANTENNA FACTOR (dB/m)	CABLE LOSS (dB)	PREAMP FACTOR (dB)	ANTENNA HEIGHT (cm)	TABLE ANGLE (Degree)	REMARK
55.92	19.25	37.44	40	-20.75	12.35	0.8	31.34	139	119	Peak
135.3	28.42	46.81	43.5	-15.08	12.08	1.27	31.74	126	263	Peak
201.45	25.43	46.13	43.5	-18.07	9.44	1.6	31.74	140	211	Peak
303.5	21.14	37.93	46	-24.86	13.03	2.06	31.88	134	114	Peak
436.5	20.62	34	46	-25.38	16.06	2.56	32	137	232	Peak
589.8	23.85	33.56	46	-22.15	19.37	3.06	32.14	124	140	Peak
ANTENNA POLARITY & TEST DISTANCE: VERTICAL AT 3 M										
FREQ. (MHz)	EMISSION LEVEL (dBuV/m)	READ LEVEL (dBuV)	LIMIT (dBuV/m)	MARGIN (dB)	ANTENNA FACTOR (dB/m)	CABLE LOSS (dB)	PREAMP FACTOR (dB)	ANTENNA HEIGHT (cm)	TABLE ANGLE (Degree)	REMARK
30.81	24.47	42.88	40	-15.53	12.14	0.57	31.12	122	295	Peak
66.99	23.26	42.94	40	-16.74	11.12	0.88	31.68	119	168	Peak
134.22	26.86	45.44	43.5	-16.64	11.94	1.26	31.78	116	353	Peak
300	20.55	37.4	46	-25.45	12.94	2.05	31.84	107	264	Peak
372.8	20.2	35.13	46	-25.8	14.68	2.32	31.93	137	174	Peak
500.2	23.15	34.66	46	-22.85	17.33	2.78	31.62	112	200	Peak

REMARKS: Emission Level = Read Level + Antenna Factor + Cable Loss - Preamp Factor

Margin value = Emission level – Limit value



A D T

EUT TEST CONDITION		MEASUREMENT DETAIL	
CHANNEL	Channel 116	FREQUENCY RANGE	30MHz ~ 1GHz
INPUT POWER	120Vac, 60 Hz	DETECTOR FUNCTION	Peak (PK)
ENVIRONMENTAL CONDITIONS	25deg. C, 65%RH	TESTED BY	Toby Tian

ANTENNA POLARITY & TEST DISTANCE: HORIZONTAL AT 3 M										
FREQ. (MHz)	EMISSION LEVEL (dBuV/m)	READ LEVEL (dBuV)	LIMIT (dBuV/m)	MARGIN (dB)	ANTENNA FACTOR (dB/m)	CABLE LOSS (dB)	PREAMP FACTOR (dB)	ANTENNA HEIGHT (cm)	TABLE ANGLE (Degree)	REMARK
43.23	18.52	35.33	40	-21.48	13.59	0.71	31.11	119	178	Peak
143.94	28.26	46.11	43.5	-15.24	12.47	1.31	31.63	116	36	Peak
200.64	25.44	46.19	43.5	-18.06	9.4	1.6	31.75	117	228	Peak
301.4	21.04	37.85	46	-24.96	12.99	2.06	31.86	135	40	Peak
435.8	20.77	34.17	46	-25.23	16.04	2.56	32	120	197	Peak
569.5	23.24	33.42	46	-22.76	18.9	3	32.08	139	155	Peak
ANTENNA POLARITY & TEST DISTANCE: VERTICAL AT 3 M										
FREQ. (MHz)	EMISSION LEVEL (dBuV/m)	READ LEVEL (dBuV)	LIMIT (dBuV/m)	MARGIN (dB)	ANTENNA FACTOR (dB/m)	CABLE LOSS (dB)	PREAMP FACTOR (dB)	ANTENNA HEIGHT (cm)	TABLE ANGLE (Degree)	REMARK
30.54	24.11	42.52	40	-15.89	12.14	0.57	31.12	101	98	Peak
86.7	23.34	45.89	40	-16.66	8.23	1	31.78	130	307	Peak
134.76	26.99	45.47	43.5	-16.51	12.01	1.27	31.76	122	145	Peak
302.8	20.84	37.64	46	-25.16	13.01	2.06	31.87	121	102	Peak
440.7	20.79	34.07	46	-25.21	16.14	2.58	32	111	124	Peak
591.9	26.61	36.3	46	-19.39	19.41	3.06	32.16	109	50	Peak

REMARKS: Emission Level = Read Level + Antenna Factor + Cable Loss - Preamp Factor
 Margin value = Emission level – Limit value



A D T

EUT TEST CONDITION		MEASUREMENT DETAIL	
CHANNEL	Channel 120	FREQUENCY RANGE	30MHz ~ 1GHz
INPUT POWER	120Vac, 60 Hz	DETECTOR FUNCTION	Peak (PK)
ENVIRONMENTAL CONDITIONS	25deg. C, 65%RH	TESTED BY	Toby Tian

ANTENNA POLARITY & TEST DISTANCE: HORIZONTAL AT 3 M										
FREQ. (MHz)	EMISSION LEVEL (dBuV/m)	READ LEVEL (dBuV)	LIMIT (dBuV/m)	MARGIN (dB)	ANTENNA FACTOR (dB/m)	CABLE LOSS (dB)	PREAMP FACTOR (dB)	ANTENNA HEIGHT (cm)	TABLE ANGLE (Degree)	REMARK
56.46	19.4	37.59	40	-20.6	12.35	0.8	31.34	127	158	Peak
135.57	27.04	45.43	43.5	-16.46	12.08	1.27	31.74	122	137	Peak
193.89	23.47	43.85	43.5	-20.03	9.77	1.56	31.71	130	52	Peak
312.6	18.68	35.28	46	-27.32	13.24	2.1	31.94	101	13	Peak
482	19.33	31.48	46	-26.67	16.96	2.72	31.83	117	112	Peak
623.4	23.99	33.1	46	-22.01	19.89	3.16	32.16	122	55	Peak
ANTENNA POLARITY & TEST DISTANCE: VERTICAL AT 3 M										
FREQ. (MHz)	EMISSION LEVEL (dBuV/m)	READ LEVEL (dBuV)	LIMIT (dBuV/m)	MARGIN (dB)	ANTENNA FACTOR (dB/m)	CABLE LOSS (dB)	PREAMP FACTOR (dB)	ANTENNA HEIGHT (cm)	TABLE ANGLE (Degree)	REMARK
38.91	21.99	38.96	40	-18.01	13.39	0.64	31	101	13	Peak
81.84	21.62	44.05	40	-18.38	8.15	0.98	31.56	108	340	Peak
133.14	26.37	45.04	43.5	-17.13	11.88	1.26	31.81	140	170	Peak
363	17.06	32.29	46	-28.94	14.45	2.28	31.96	105	44	Peak
495.3	21.18	32.88	46	-24.82	17.23	2.76	31.69	122	128	Peak
628.3	24.71	33.74	46	-21.29	19.95	3.17	32.15	139	286	Peak

REMARKS: Emission Level = Read Level + Antenna Factor + Cable Loss - Preamp Factor
 Margin value = Emission level – Limit value



A D T

EUT TEST CONDITION		MEASUREMENT DETAIL	
CHANNEL	Channel 140	FREQUENCY RANGE	30MHz ~ 1GHz
INPUT POWER	120Vac, 60 Hz	DETECTOR FUNCTION	Peak (PK)
ENVIRONMENTAL CONDITIONS	25deg. C, 65%RH	TESTED BY	Toby Tian

ANTENNA POLARITY & TEST DISTANCE: HORIZONTAL AT 3 M										
FREQ. (MHz)	EMISSION LEVEL (dBuV/m)	READ LEVEL (dBuV)	LIMIT (dBuV/m)	MARGIN (dB)	ANTENNA FACTOR (dB/m)	CABLE LOSS (dB)	PREAMP FACTOR (dB)	ANTENNA HEIGHT (cm)	TABLE ANGLE (Degree)	REMARK
44.04	20.54	37.35	40	-19.46	13.59	0.71	31.11	125	207	Peak
144.48	28.44	46.24	43.5	-15.06	12.51	1.32	31.63	133	112	Peak
201.18	25.25	46	43.5	-18.25	9.4	1.6	31.75	136	325	Peak
311.2	20.71	37.34	46	-25.29	13.22	2.09	31.94	121	235	Peak
457.5	20.96	33.83	46	-25.04	16.48	2.64	31.99	122	5	Peak
582.1	23.17	33.06	46	-22.83	19.19	3.04	32.12	118	201	Peak
ANTENNA POLARITY & TEST DISTANCE: VERTICAL AT 3 M										
FREQ. (MHz)	EMISSION LEVEL (dBuV/m)	READ LEVEL (dBuV)	LIMIT (dBuV/m)	MARGIN (dB)	ANTENNA FACTOR (dB/m)	CABLE LOSS (dB)	PREAMP FACTOR (dB)	ANTENNA HEIGHT (cm)	TABLE ANGLE (Degree)	REMARK
30.81	24.75	43.16	40	-15.25	12.14	0.57	31.12	117	286	Peak
87.24	23.3	45.86	40	-16.7	8.25	1.01	31.82	111	67	Peak
134.22	26.6	45.18	43.5	-16.9	11.94	1.26	31.78	105	91	Peak
303.5	20.68	37.47	46	-25.32	13.03	2.06	31.88	133	232	Peak
500.2	24.52	36.03	46	-21.48	17.33	2.78	31.62	106	279	Peak
592.6	25.91	35.58	46	-20.09	19.43	3.07	32.17	112	228	Peak

REMARKS: Emission Level = Read Level + Antenna Factor + Cable Loss - Preamp Factor
 Margin value = Emission level – Limit value



A D T

EUT TEST CONDITION		MEASUREMENT DETAIL	
CHANNEL	Channel 149	FREQUENCY RANGE	30MHz ~ 1GHz
INPUT POWER	120Vac, 60 Hz	DETECTOR FUNCTION	Peak (PK)
ENVIRONMENTAL CONDITIONS	25deg. C, 65%RH	TESTED BY	Toby Tian

ANTENNA POLARITY & TEST DISTANCE: HORIZONTAL AT 3 M

FREQ. (MHz)	EMISSION LEVEL (dBuV/m)	READ LEVEL (dBuV)	LIMIT (dBuV/m)	MARGIN (dB)	ANTENNA FACTOR (dB/m)	CABLE LOSS (dB)	PREAMP FACTOR (dB)	ANTENNA HEIGHT (cm)	TABLE ANGLE (Degree)	REMARK
127.74	23.35	42.45	43.5	-20.15	11.55	1.23	31.88	137	113	Peak
185.79	26.29	46.17	43.5	-17.21	10.33	1.53	31.74	117	307	Peak
197.13	26.53	47.12	43.5	-16.97	9.57	1.58	31.74	112	293	Peak
559	21.77	32.19	46	-24.23	18.66	2.97	32.05	110	4	Peak
650.7	24.1	32.65	46	-21.9	20.22	3.24	32.01	125	267	Peak
780.2	25.91	31.75	46	-20.09	21.94	3.65	31.43	104	292	Peak

ANTENNA POLARITY & TEST DISTANCE: VERTICAL AT 3 M

FREQ. (MHz)	EMISSION LEVEL (dBuV/m)	READ LEVEL (dBuV)	LIMIT (dBuV/m)	MARGIN (dB)	ANTENNA FACTOR (dB/m)	CABLE LOSS (dB)	PREAMP FACTOR (dB)	ANTENNA HEIGHT (cm)	TABLE ANGLE (Degree)	REMARK
83.19	29.22	51.7	40	-10.78	8.18	0.99	31.65	132	119	Peak
117.75	26.61	46.58	43.5	-16.89	10.74	1.17	31.88	127	261	Peak
127.74	26.25	45.35	43.5	-17.25	11.55	1.23	31.88	118	62	Peak
560.4	21.72	32.1	46	-24.28	18.7	2.98	32.06	135	335	Peak
635.3	23.13	32.01	46	-22.87	20.03	3.2	32.11	130	243	Peak
745.9	25.4	31.75	46	-20.6	21.46	3.56	31.37	132	95	Peak

REMARKS: Emission Level = Read Level + Antenna Factor + Cable Loss - Preamp Factor

Margin value = Emission level – Limit value



A D T

EUT TEST CONDITION		MEASUREMENT DETAIL	
CHANNEL	Channel 157	FREQUENCY RANGE	30MHz ~ 1GHz
INPUT POWER	120Vac, 60 Hz	DETECTOR FUNCTION	Peak (PK)
ENVIRONMENTAL CONDITIONS	25deg. C, 65%RH	TESTED BY	Toby Tian

ANTENNA POLARITY & TEST DISTANCE: HORIZONTAL AT 3 M										
FREQ. (MHz)	EMISSION LEVEL (dBuV/m)	READ LEVEL (dBuV)	LIMIT (dBuV/m)	MARGIN (dB)	ANTENNA FACTOR (dB/m)	CABLE LOSS (dB)	PREAMP FACTOR (dB)	ANTENNA HEIGHT (cm)	TABLE ANGLE (Degree)	REMARK
127.74	22.13	41.23	43.5	-21.37	11.55	1.23	31.88	128	118	Peak
145.02	24.61	42.37	43.5	-18.89	12.54	1.32	31.62	134	49	Peak
190.92	27.85	48	43.5	-15.65	9.98	1.55	31.68	123	64	Peak
541.5	21.48	32.05	46	-24.52	18.26	2.92	31.75	102	2	Peak
618.5	22.87	32.06	46	-23.13	19.83	3.14	32.16	107	207	Peak
731.9	25.36	32.14	46	-20.64	21.27	3.52	31.57	132	310	Peak
ANTENNA POLARITY & TEST DISTANCE: VERTICAL AT 3 M										
FREQ. (MHz)	EMISSION LEVEL (dBuV/m)	READ LEVEL (dBuV)	LIMIT (dBuV/m)	MARGIN (dB)	ANTENNA FACTOR (dB/m)	CABLE LOSS (dB)	PREAMP FACTOR (dB)	ANTENNA HEIGHT (cm)	TABLE ANGLE (Degree)	REMARK
82.11	28.96	51.42	40	-11.04	8.16	0.98	31.6	127	121	Peak
117.75	26.75	46.72	43.5	-16.75	10.74	1.17	31.88	111	340	Peak
130.44	21.82	40.68	43.5	-21.68	11.75	1.25	31.86	121	14	Peak
611.5	21.97	31.2	46	-24.03	19.74	3.12	32.09	103	182	Peak
658.4	23.59	31.97	46	-22.41	20.31	3.27	31.96	100	29	Peak
748	25.03	31.31	46	-20.97	21.49	3.57	31.34	135	213	Peak

REMARKS: Emission Level = Read Level + Antenna Factor + Cable Loss - Preamp Factor
 Margin value = Emission level – Limit value



A D T

EUT TEST CONDITION		MEASUREMENT DETAIL	
CHANNEL	Channel 165	FREQUENCY RANGE	30MHz ~ 1GHz
INPUT POWER	120Vac, 60 Hz	DETECTOR FUNCTION	Peak (PK)
ENVIRONMENTAL CONDITIONS	25deg. C, 65%RH	TESTED BY	Toby Tian

ANTENNA POLARITY & TEST DISTANCE: HORIZONTAL AT 3 M										
FREQ. (MHz)	EMISSION LEVEL (dBuV/m)	READ LEVEL (dBuV)	LIMIT (dBuV/m)	MARGIN (dB)	ANTENNA FACTOR (dB/m)	CABLE LOSS (dB)	PREAMP FACTOR (dB)	ANTENNA HEIGHT (cm)	TABLE ANGLE (Degree)	REMARK
145.29	23.52	41.28	43.5	-19.98	12.54	1.32	31.62	135	31	Peak
182.82	26.24	45.99	43.5	-17.26	10.53	1.51	31.79	140	240	Peak
194.7	27.69	48.14	43.5	-15.81	9.7	1.57	31.72	106	77	Peak
661.9	23.68	31.96	46	-22.32	20.35	3.29	31.92	100	357	Peak
739.6	25.3	31.85	46	-20.7	21.38	3.55	31.48	127	96	Peak
765.5	26.36	32.39	46	-19.64	21.74	3.61	31.38	107	178	Peak

ANTENNA POLARITY & TEST DISTANCE: VERTICAL AT 3 M										
FREQ. (MHz)	EMISSION LEVEL (dBuV/m)	READ LEVEL (dBuV)	LIMIT (dBuV/m)	MARGIN (dB)	ANTENNA FACTOR (dB/m)	CABLE LOSS (dB)	PREAMP FACTOR (dB)	ANTENNA HEIGHT (cm)	TABLE ANGLE (Degree)	REMARK
79.14	30.51	52.71	40	-9.49	8.37	0.97	31.54	122	222	Peak
84	27.78	50.28	40	-12.22	8.2	0.99	31.69	134	286	Peak
128.01	28.15	47.25	43.5	-15.35	11.55	1.23	31.88	125	341	Peak
588.4	23.39	33.13	46	-22.61	19.34	3.06	32.14	105	195	Peak
671.7	24.06	32.07	46	-21.94	20.48	3.33	31.82	114	305	Peak
737.5	24.68	31.31	46	-21.32	21.34	3.54	31.51	119	293	Peak

REMARKS: Emission Level = Read Level + Antenna Factor + Cable Loss - Preamp Factor
Margin value = Emission level – Limit value



A D T

802.11n (20MHz)

EUT TEST CONDITION		MEASUREMENT DETAIL	
CHANNEL	Channel 36	FREQUENCY RANGE	30MHz ~ 1GHz
INPUT POWER	120Vac, 60 Hz	DETECTOR FUNCTION	Peak (PK)
ENVIRONMENTAL CONDITIONS	25deg. C, 65%RH	TESTED BY	Toby Tian

ANTENNA POLARITY & TEST DISTANCE: HORIZONTAL AT 3 M										
FREQ. (MHz)	EMISSION LEVEL (dBuV/m)	READ LEVEL (dBuV)	LIMIT (dBuV/m)	MARGIN (dB)	ANTENNA FACTOR (dB/m)	CABLE LOSS (dB)	PREAMP FACTOR (dB)	ANTENNA HEIGHT (cm)	TABLE ANGLE (Degree)	REMARK
136.11	28.41	46.8	43.5	-15.09	12.08	1.27	31.74	102	125	Peak
141.24	29.08	47	43.5	-14.42	12.41	1.3	31.63	110	75	Peak
203.61	29.03	49.6	43.5	-14.47	9.52	1.61	31.7	108	210	Peak
584.9	22.86	32.69	46	-23.14	19.26	3.04	32.13	137	353	Peak
631.8	23.31	32.27	46	-22.69	19.99	3.18	32.13	131	164	Peak
748.7	25.4	31.65	46	-20.6	21.5	3.57	31.32	134	58	Peak

ANTENNA POLARITY & TEST DISTANCE: VERTICAL AT 3 M										
FREQ. (MHz)	EMISSION LEVEL (dBuV/m)	READ LEVEL (dBuV)	LIMIT (dBuV/m)	MARGIN (dB)	ANTENNA FACTOR (dB/m)	CABLE LOSS (dB)	PREAMP FACTOR (dB)	ANTENNA HEIGHT (cm)	TABLE ANGLE (Degree)	REMARK
86.43	26.61	49.16	40	-13.39	8.23	1	31.78	123	280	Peak
132.6	25.71	44.38	43.5	-17.79	11.88	1.26	31.81	105	269	Peak
138.27	24.96	43.06	43.5	-18.54	12.27	1.29	31.66	111	131	Peak
657.7	24.03	32.42	46	-21.97	20.3	3.27	31.96	127	183	Peak
735.4	25.54	32.23	46	-20.46	21.31	3.53	31.53	125	196	Peak
783	25.65	31.44	46	-20.35	21.98	3.65	31.42	122	131	Peak

REMARKS: Emission Level = Read Level + Antenna Factor + Cable Loss - Preamp Factor

Margin value = Emission level – Limit value



A D T

EUT TEST CONDITION		MEASUREMENT DETAIL	
CHANNEL	Channel 44	FREQUENCY RANGE	30MHz ~ 1GHz
INPUT POWER	120Vac, 60 Hz	DETECTOR FUNCTION	Peak (PK)
ENVIRONMENTAL CONDITIONS	25deg. C, 65%RH	TESTED BY	Toby Tian

ANTENNA POLARITY & TEST DISTANCE: HORIZONTAL AT 3 M

FREQ. (MHz)	EMISSION LEVEL (dBuV/m)	READ LEVEL (dBuV)	LIMIT (dBuV/m)	MARGIN (dB)	ANTENNA FACTOR (dB/m)	CABLE LOSS (dB)	PREAMP FACTOR (dB)	ANTENNA HEIGHT (cm)	TABLE ANGLE (Degree)	REMARK
130.98	26.32	45.18	43.5	-17.18	11.75	1.25	31.86	110	217	Peak
143.13	27.42	45.27	43.5	-16.08	12.47	1.31	31.63	133	55	Peak
187.68	27.86	47.83	43.5	-15.64	10.19	1.54	31.7	118	152	Peak
676.6	23.64	31.59	46	-22.36	20.54	3.34	31.83	113	232	Peak
738.2	24.66	31.27	46	-21.34	21.35	3.54	31.5	128	162	Peak
774.6	25.93	31.79	46	-20.07	21.87	3.63	31.36	102	258	Peak

ANTENNA POLARITY & TEST DISTANCE: VERTICAL AT 3 M

FREQ. (MHz)	EMISSION LEVEL (dBuV/m)	READ LEVEL (dBuV)	LIMIT (dBuV/m)	MARGIN (dB)	ANTENNA FACTOR (dB/m)	CABLE LOSS (dB)	PREAMP FACTOR (dB)	ANTENNA HEIGHT (cm)	TABLE ANGLE (Degree)	REMARK
87.24	22.52	45.08	40	-17.48	8.25	1.01	31.82	106	35	Peak
128.55	21.8	40.84	43.5	-21.7	11.61	1.23	31.88	109	333	Peak
142.05	24.06	41.94	43.5	-19.44	12.44	1.31	31.63	134	39	Peak
658.4	23.14	31.52	46	-22.86	20.31	3.27	31.96	122	276	Peak
739.6	26.33	32.88	46	-19.67	21.38	3.55	31.48	119	356	Peak
790.7	26.73	32.37	46	-19.27	22.09	3.67	31.4	100	330	Peak

REMARKS: Emission Level = Read Level + Antenna Factor + Cable Loss - Preamp Factor
 Margin value = Emission level – Limit value



A D T

EUT TEST CONDITION		MEASUREMENT DETAIL	
CHANNEL	Channel 48	FREQUENCY RANGE	30MHz ~ 1GHz
INPUT POWER	120Vac, 60 Hz	DETECTOR FUNCTION	Peak (PK)
ENVIRONMENTAL CONDITIONS	25deg. C, 65%RH	TESTED BY	Toby Tian

ANTENNA POLARITY & TEST DISTANCE: HORIZONTAL AT 3 M										
FREQ. (MHz)	EMISSION LEVEL (dBuV/m)	READ LEVEL (dBuV)	LIMIT (dBuV/m)	MARGIN (dB)	ANTENNA FACTOR (dB/m)	CABLE LOSS (dB)	PREAMP FACTOR (dB)	ANTENNA HEIGHT (cm)	TABLE ANGLE (Degree)	REMARK
143.67	27.89	45.74	43.5	-15.61	12.47	1.31	31.63	128	344	Peak
184.71	26.86	46.65	43.5	-16.64	10.46	1.52	31.77	128	137	Peak
206.58	28.71	49.09	43.5	-14.79	9.65	1.63	31.66	135	176	Peak
654.9	23.41	31.87	46	-22.59	20.27	3.26	31.99	107	241	Peak
722.1	24.66	31.67	46	-21.34	21.13	3.5	31.64	113	300	Peak
769	25.44	31.34	46	-20.56	21.79	3.62	31.31	128	179	Peak
ANTENNA POLARITY & TEST DISTANCE: VERTICAL AT 3 M										
FREQ. (MHz)	EMISSION LEVEL (dBuV/m)	READ LEVEL (dBuV)	LIMIT (dBuV/m)	MARGIN (dB)	ANTENNA FACTOR (dB/m)	CABLE LOSS (dB)	PREAMP FACTOR (dB)	ANTENNA HEIGHT (cm)	TABLE ANGLE (Degree)	REMARK
81.84	24.95	47.38	40	-15.05	8.15	0.98	31.56	111	25	Peak
135.3	25.15	43.54	43.5	-18.35	12.08	1.27	31.74	126	109	Peak
188.49	22.59	42.56	43.5	-20.91	10.19	1.54	31.7	112	263	Peak
669.6	23.29	31.36	46	-22.71	20.44	3.31	31.82	115	134	Peak
717.2	24.99	32.14	46	-21.01	21.05	3.48	31.68	119	321	Peak
769.7	25.12	30.99	46	-20.88	21.81	3.62	31.3	122	95	Peak

REMARKS: Emission Level = Read Level + Antenna Factor + Cable Loss - Preamp Factor
Margin value = Emission level – Limit value



A D T

EUT TEST CONDITION		MEASUREMENT DETAIL	
CHANNEL	Channel 52	FREQUENCY RANGE	30MHz ~ 1GHz
INPUT POWER	120Vac, 60 Hz	DETECTOR FUNCTION	Peak (PK)
ENVIRONMENTAL CONDITIONS	25deg. C, 65%RH	TESTED BY	Toby Tian

ANTENNA POLARITY & TEST DISTANCE: HORIZONTAL AT 3 M										
FREQ. (MHz)	EMISSION LEVEL (dBuV/m)	READ LEVEL (dBuV)	LIMIT (dBuV/m)	MARGIN (dB)	ANTENNA FACTOR (dB/m)	CABLE LOSS (dB)	PREAMP FACTOR (dB)	ANTENNA HEIGHT (cm)	TABLE ANGLE (Degree)	REMARK
55.65	19.1	37.18	40	-20.9	12.45	0.8	31.33	133	280	Peak
145.83	29.28	47.04	43.5	-14.22	12.54	1.32	31.62	112	233	Peak
200.1	25.77	46.59	43.5	-17.73	9.36	1.59	31.77	130	321	Peak
304.2	21.09	37.85	46	-24.91	13.06	2.07	31.89	106	143	Peak
494.6	21.55	33.28	46	-24.45	17.21	2.76	31.7	124	184	Peak
624.8	23.86	32.96	46	-22.14	19.9	3.16	32.16	116	104	Peak
ANTENNA POLARITY & TEST DISTANCE: VERTICAL AT 3 M										
FREQ. (MHz)	EMISSION LEVEL (dBuV/m)	READ LEVEL (dBuV)	LIMIT (dBuV/m)	MARGIN (dB)	ANTENNA FACTOR (dB/m)	CABLE LOSS (dB)	PREAMP FACTOR (dB)	ANTENNA HEIGHT (cm)	TABLE ANGLE (Degree)	REMARK
30.81	25.14	43.55	40	-14.86	12.14	0.57	31.12	100	166	Peak
87.24	24.06	46.62	40	-15.94	8.25	1.01	31.82	136	290	Peak
136.11	25.76	44.15	43.5	-17.74	12.08	1.27	31.74	108	206	Peak
342	18.73	34.39	46	-27.27	13.96	2.2	31.82	129	35	Peak
436.5	22.68	36.06	46	-23.32	16.06	2.56	32	123	21	Peak
585.6	24.15	33.95	46	-21.85	19.28	3.05	32.13	113	220	Peak

REMARKS: Emission Level = Read Level + Antenna Factor + Cable Loss - Preamp Factor
 Margin value = Emission level – Limit value



A D T

EUT TEST CONDITION		MEASUREMENT DETAIL	
CHANNEL	Channel 60	FREQUENCY RANGE	30MHz ~ 1GHz
INPUT POWER	120Vac, 60 Hz	DETECTOR FUNCTION	Peak (PK)
ENVIRONMENTAL CONDITIONS	25deg. C, 65%RH	TESTED BY	Toby Tian

ANTENNA POLARITY & TEST DISTANCE: HORIZONTAL AT 3 M										
FREQ. (MHz)	EMISSION LEVEL (dBuV/m)	READ LEVEL (dBuV)	LIMIT (dBuV/m)	MARGIN (dB)	ANTENNA FACTOR (dB/m)	CABLE LOSS (dB)	PREAMP FACTOR (dB)	ANTENNA HEIGHT (cm)	TABLE ANGLE (Degree)	REMARK
43.5	19.61	36.42	40	-20.39	13.59	0.71	31.11	105	123	Peak
146.64	28.49	46.2	43.5	-15.01	12.58	1.33	31.62	121	293	Peak
203.34	25.15	45.72	43.5	-18.35	9.52	1.61	31.7	111	254	Peak
302.8	21.9	38.7	46	-24.1	13.01	2.06	31.87	113	136	Peak
479.2	21.23	33.46	46	-24.77	16.91	2.71	31.85	111	278	Peak
657	24.44	32.85	46	-21.56	20.29	3.27	31.97	124	33	Peak
ANTENNA POLARITY & TEST DISTANCE: VERTICAL AT 3 M										
FREQ. (MHz)	EMISSION LEVEL (dBuV/m)	READ LEVEL (dBuV)	LIMIT (dBuV/m)	MARGIN (dB)	ANTENNA FACTOR (dB/m)	CABLE LOSS (dB)	PREAMP FACTOR (dB)	ANTENNA HEIGHT (cm)	TABLE ANGLE (Degree)	REMARK
30.81	25.71	44.12	40	-14.29	12.14	0.57	31.12	117	99	Peak
133.68	26.64	45.22	43.5	-16.86	11.94	1.26	31.78	124	131	Peak
193.62	24.66	45.04	43.5	-18.84	9.77	1.56	31.71	115	81	Peak
303.5	19.49	36.28	46	-26.51	13.03	2.06	31.88	120	180	Peak
457.5	22.95	35.82	46	-23.05	16.48	2.64	31.99	114	247	Peak
662.6	25.27	33.53	46	-20.73	20.36	3.29	31.91	109	114	Peak

REMARKS: Emission Level = Read Level + Antenna Factor + Cable Loss - Preamp Factor
Margin value = Emission level – Limit value



A D T

EUT TEST CONDITION		MEASUREMENT DETAIL	
CHANNEL	Channel 64	FREQUENCY RANGE	30MHz ~ 1GHz
INPUT POWER	120Vac, 60 Hz	DETECTOR FUNCTION	Peak (PK)
ENVIRONMENTAL CONDITIONS	25deg. C, 65%RH	TESTED BY	Toby Tian

ANTENNA POLARITY & TEST DISTANCE: HORIZONTAL AT 3 M										
FREQ. (MHz)	EMISSION LEVEL (dBuV/m)	READ LEVEL (dBuV)	LIMIT (dBuV/m)	MARGIN (dB)	ANTENNA FACTOR (dB/m)	CABLE LOSS (dB)	PREAMP FACTOR (dB)	ANTENNA HEIGHT (cm)	TABLE ANGLE (Degree)	REMARK
43.5	19.69	36.5	40	-20.31	13.59	0.71	31.11	130	142	Peak
145.83	28.95	46.71	43.5	-14.55	12.54	1.32	31.62	108	135	Peak
202.53	25.99	46.62	43.5	-17.51	9.48	1.61	31.72	114	336	Peak
304.9	21.13	37.89	46	-24.87	13.06	2.07	31.89	133	175	Peak
479.2	20.65	32.88	46	-25.35	16.91	2.71	31.85	123	205	Peak
559.7	23.24	33.65	46	-22.76	18.68	2.97	32.06	138	230	Peak
ANTENNA POLARITY & TEST DISTANCE: VERTICAL AT 3 M										
FREQ. (MHz)	EMISSION LEVEL (dBuV/m)	READ LEVEL (dBuV)	LIMIT (dBuV/m)	MARGIN (dB)	ANTENNA FACTOR (dB/m)	CABLE LOSS (dB)	PREAMP FACTOR (dB)	ANTENNA HEIGHT (cm)	TABLE ANGLE (Degree)	REMARK
30.81	24.44	42.85	40	-15.56	12.14	0.57	31.12	107	132	Peak
86.97	23.39	45.95	40	-16.61	8.25	1.01	31.82	112	251	Peak
134.76	25.39	43.87	43.5	-18.11	12.01	1.27	31.76	137	208	Peak
310.5	18.76	35.42	46	-27.24	13.2	2.09	31.95	111	165	Peak
436.5	20.89	34.27	46	-25.11	16.06	2.56	32	109	183	Peak
573	23.43	33.52	46	-22.57	18.99	3.01	32.09	137	328	Peak

REMARKS: Emission Level = Read Level + Antenna Factor + Cable Loss - Preamp Factor
 Margin value = Emission level – Limit value



A D T

EUT TEST CONDITION		MEASUREMENT DETAIL	
CHANNEL	Channel 100	FREQUENCY RANGE	30MHz ~ 1GHz
INPUT POWER	120Vac, 60 Hz	DETECTOR FUNCTION	Peak (PK)
ENVIRONMENTAL CONDITIONS	25deg. C, 65%RH	TESTED BY	Toby Tian

ANTENNA POLARITY & TEST DISTANCE: HORIZONTAL AT 3 M										
FREQ. (MHz)	EMISSION LEVEL (dBuV/m)	READ LEVEL (dBuV)	LIMIT (dBuV/m)	MARGIN (dB)	ANTENNA FACTOR (dB/m)	CABLE LOSS (dB)	PREAMP FACTOR (dB)	ANTENNA HEIGHT (cm)	TABLE ANGLE (Degree)	REMARK
43.77	20.76	37.57	40	-19.24	13.59	0.71	31.11	108	213	Peak
145.02	28.35	46.11	43.5	-15.15	12.54	1.32	31.62	119	82	Peak
201.45	25.65	46.35	43.5	-17.85	9.44	1.6	31.74	114	342	Peak
304.9	21.31	38.07	46	-24.69	13.06	2.07	31.89	134	16	Peak
479.2	22.22	34.45	46	-23.78	16.91	2.71	31.85	138	312	Peak
652.1	25.93	34.46	46	-20.07	20.23	3.25	32.01	124	340	Peak
ANTENNA POLARITY & TEST DISTANCE: VERTICAL AT 3 M										
FREQ. (MHz)	EMISSION LEVEL (dBuV/m)	READ LEVEL (dBuV)	LIMIT (dBuV/m)	MARGIN (dB)	ANTENNA FACTOR (dB/m)	CABLE LOSS (dB)	PREAMP FACTOR (dB)	ANTENNA HEIGHT (cm)	TABLE ANGLE (Degree)	REMARK
30.54	24.88	43.29	40	-15.12	12.14	0.57	31.12	122	234	Peak
87.51	23.6	46.16	40	-16.4	8.25	1.01	31.82	128	85	Peak
136.38	26.25	44.54	43.5	-17.25	12.14	1.28	31.71	108	250	Peak
300.7	22.1	38.94	46	-23.9	12.96	2.05	31.85	135	54	Peak
457.5	21.87	34.74	46	-24.13	16.48	2.64	31.99	127	235	Peak
592.6	25.5	35.17	46	-20.5	19.43	3.07	32.17	107	84	Peak

REMARKS: Emission Level = Read Level + Antenna Factor + Cable Loss - Preamp Factor
 Margin value = Emission level – Limit value



A D T

EUT TEST CONDITION		MEASUREMENT DETAIL	
CHANNEL	Channel 116	FREQUENCY RANGE	30MHz ~ 1GHz
INPUT POWER	120Vac, 60 Hz	DETECTOR FUNCTION	Peak (PK)
ENVIRONMENTAL CONDITIONS	25deg. C, 65%RH	TESTED BY	Toby Tian

ANTENNA POLARITY & TEST DISTANCE: HORIZONTAL AT 3 M										
FREQ. (MHz)	EMISSION LEVEL (dBuV/m)	READ LEVEL (dBuV)	LIMIT (dBuV/m)	MARGIN (dB)	ANTENNA FACTOR (dB/m)	CABLE LOSS (dB)	PREAMP FACTOR (dB)	ANTENNA HEIGHT (cm)	TABLE ANGLE (Degree)	REMARK
56.46	18.89	37.08	40	-21.11	12.35	0.8	31.34	133	157	Peak
144.75	28.56	46.36	43.5	-14.94	12.51	1.32	31.63	137	242	Peak
201.45	25.65	46.35	43.5	-17.85	9.44	1.6	31.74	103	285	Peak
302.8	21.71	38.51	46	-24.29	13.01	2.06	31.87	127	262	Peak
450.5	20.58	33.59	46	-25.42	16.35	2.62	31.98	123	89	Peak
597.5	23.86	33.46	46	-22.14	19.54	3.08	32.22	103	176	Peak
ANTENNA POLARITY & TEST DISTANCE: VERTICAL AT 3 M										
FREQ. (MHz)	EMISSION LEVEL (dBuV/m)	READ LEVEL (dBuV)	LIMIT (dBuV/m)	MARGIN (dB)	ANTENNA FACTOR (dB/m)	CABLE LOSS (dB)	PREAMP FACTOR (dB)	ANTENNA HEIGHT (cm)	TABLE ANGLE (Degree)	REMARK
30.54	24.88	43.29	40	-15.12	12.14	0.57	31.12	110	159	Peak
87.24	23.59	46.15	40	-16.41	8.25	1.01	31.82	116	14	Peak
134.22	26.63	45.21	43.5	-16.87	11.94	1.26	31.78	102	308	Peak
307	19.61	36.32	46	-26.39	13.13	2.08	31.92	126	268	Peak
372.8	19.16	34.09	46	-26.84	14.68	2.32	31.93	104	351	Peak
561.8	24.04	34.4	46	-21.96	18.72	2.98	32.06	137	110	Peak

REMARKS: Emission Level = Read Level + Antenna Factor + Cable Loss - Preamp Factor
 Margin value = Emission level – Limit value



A D T

EUT TEST CONDITION		MEASUREMENT DETAIL	
CHANNEL	Channel 120	FREQUENCY RANGE	30MHz ~ 1GHz
INPUT POWER	120Vac, 60 Hz	DETECTOR FUNCTION	Peak (PK)
ENVIRONMENTAL CONDITIONS	25deg. C, 65%RH	TESTED BY	Toby Tian

ANTENNA POLARITY & TEST DISTANCE: HORIZONTAL AT 3 M										
FREQ. (MHz)	EMISSION LEVEL (dBuV/m)	READ LEVEL (dBuV)	LIMIT (dBuV/m)	MARGIN (dB)	ANTENNA FACTOR (dB/m)	CABLE LOSS (dB)	PREAMP FACTOR (dB)	ANTENNA HEIGHT (cm)	TABLE ANGLE (Degree)	REMARK
44.31	17.03	33.84	40	-22.97	13.6	0.73	31.14	134	119	Peak
132.87	25.28	43.95	43.5	-18.22	11.88	1.26	31.81	131	70	Peak
191.73	23.01	43.23	43.5	-20.49	9.91	1.56	31.69	131	47	Peak
370.7	17.34	32.32	46	-28.66	14.63	2.31	31.92	118	277	Peak
500.2	20.83	32.34	46	-25.17	17.33	2.78	31.62	127	222	Peak
654.2	23.52	31.98	46	-22.48	20.27	3.26	31.99	108	73	Peak

ANTENNA POLARITY & TEST DISTANCE: VERTICAL AT 3 M										
FREQ. (MHz)	EMISSION LEVEL (dBuV/m)	READ LEVEL (dBuV)	LIMIT (dBuV/m)	MARGIN (dB)	ANTENNA FACTOR (dB/m)	CABLE LOSS (dB)	PREAMP FACTOR (dB)	ANTENNA HEIGHT (cm)	TABLE ANGLE (Degree)	REMARK
38.37	21.8	38.77	40	-18.2	13.39	0.64	31	117	119	Peak
68.07	22.11	41.96	40	-17.89	11	0.88	31.73	136	356	Peak
192.81	24.66	44.96	43.5	-18.84	9.84	1.56	31.7	116	326	Peak
335	16.61	32.47	46	-29.39	13.78	2.17	31.81	130	172	Peak
441.4	17.92	31.18	46	-28.08	16.16	2.58	32	113	162	Peak
615	22.68	31.88	46	-23.32	19.79	3.13	32.12	117	81	Peak

REMARKS: Emission Level = Read Level + Antenna Factor + Cable Loss - Preamp Factor
 Margin value = Emission level – Limit value



A D T

EUT TEST CONDITION		MEASUREMENT DETAIL	
CHANNEL	Channel 140	FREQUENCY RANGE	30MHz ~ 1GHz
INPUT POWER	120Vac, 60 Hz	DETECTOR FUNCTION	Peak (PK) Quasi-peak (QP)
ENVIRONMENTAL CONDITIONS	25deg. C, 65%RH	TESTED BY	Toby Tian

ANTENNA POLARITY & TEST DISTANCE: HORIZONTAL AT 3 M										
FREQ. (MHz)	EMISSION LEVEL (dBuV/m)	READ LEVEL (dBuV)	LIMIT (dBuV/m)	MARGIN (dB)	ANTENNA FACTOR (dB/m)	CABLE LOSS (dB)	PREAMP FACTOR (dB)	ANTENNA HEIGHT (cm)	TABLE ANGLE (Degree)	REMARK
43.5	18.94	35.75	40	-21.06	13.59	0.71	31.11	100	5	Peak
143.67	28.23	46.08	43.5	-15.27	12.47	1.31	31.63	119	254	Peak
201.45	25.61	46.31	43.5	-17.89	9.44	1.6	31.74	138	38	Peak
304.2	22.01	38.77	46	-23.99	13.06	2.07	31.89	101	88	Peak
457.5	21.35	34.22	46	-24.65	16.48	2.64	31.99	133	105	Peak
568.8	23.12	33.32	46	-22.88	18.88	3	32.08	119	183	Peak
ANTENNA POLARITY & TEST DISTANCE: VERTICAL AT 3 M										
FREQ. (MHz)	EMISSION LEVEL (dBuV/m)	READ LEVEL (dBuV)	LIMIT (dBuV/m)	MARGIN (dB)	ANTENNA FACTOR (dB/m)	CABLE LOSS (dB)	PREAMP FACTOR (dB)	ANTENNA HEIGHT (cm)	TABLE ANGLE (Degree)	REMARK
30.54	24.72	43.13	40	-15.28	12.14	0.57	31.12	103	280	Peak
86.97	23.57	46.13	40	-16.43	8.25	1.01	31.82	117	193	Peak
134.22	27.25	45.83	43.5	-16.25	11.94	1.26	31.78	112	310	Peak
300.7	20.62	37.46	46	-25.38	12.96	2.05	31.85	132	83	Peak
435.8	20.6	34	46	-25.4	16.04	2.56	32	111	78	Peak
566.7	23.86	34.1	46	-22.14	18.84	2.99	32.07	124	345	Peak

REMARKS: Emission Level = Read Level + Antenna Factor + Cable Loss - Preamp Factor

Margin value = Emission level – Limit value



A D T

EUT TEST CONDITION		MEASUREMENT DETAIL	
CHANNEL	Channel 149	FREQUENCY RANGE	30MHz ~ 1GHz
INPUT POWER	120Vac, 60 Hz	DETECTOR FUNCTION	Peak (PK)
ENVIRONMENTAL CONDITIONS	25deg. C, 65%RH	TESTED BY	Toby Tian

ANTENNA POLARITY & TEST DISTANCE: HORIZONTAL AT 3 M

FREQ. (MHz)	EMISSION LEVEL (dBuV/m)	READ LEVEL (dBuV)	LIMIT (dBuV/m)	MARGIN (dB)	ANTENNA FACTOR (dB/m)	CABLE LOSS (dB)	PREAMP FACTOR (dB)	ANTENNA HEIGHT (cm)	TABLE ANGLE (Degree)	REMARK
128.82	22.4	41.44	43.5	-21.1	11.61	1.23	31.88	130	98	Peak
186.06	26.83	46.71	43.5	-16.67	10.33	1.53	31.74	119	334	Peak
197.13	26.2	46.79	43.5	-17.3	9.57	1.58	31.74	115	222	Peak
642.3	23.46	32.2	46	-22.54	20.12	3.22	32.08	100	175	Peak
732.6	25.28	32.06	46	-20.72	21.27	3.52	31.57	120	195	Peak
782.3	26.42	32.21	46	-19.58	21.98	3.65	31.42	129	348	Peak

ANTENNA POLARITY & TEST DISTANCE: VERTICAL AT 3 M

FREQ. (MHz)	EMISSION LEVEL (dBuV/m)	READ LEVEL (dBuV)	LIMIT (dBuV/m)	MARGIN (dB)	ANTENNA FACTOR (dB/m)	CABLE LOSS (dB)	PREAMP FACTOR (dB)	ANTENNA HEIGHT (cm)	TABLE ANGLE (Degree)	REMARK
79.68	30.61	52.81	40	-9.39	8.37	0.97	31.54	129	221	Peak
84	26.04	48.54	40	-13.96	8.2	0.99	31.69	131	79	Peak
127.2	27.73	46.92	43.5	-15.77	11.48	1.22	31.89	103	356	Peak
672.4	23.48	31.49	46	-22.52	20.48	3.33	31.82	124	45	Peak
724.9	24.4	31.37	46	-21.6	21.16	3.5	31.63	140	47	Peak
780.9	26.11	31.93	46	-19.89	21.96	3.65	31.43	111	223	Peak

REMARKS: Emission Level = Read Level + Antenna Factor + Cable Loss - Preamp Factor

Margin value = Emission level – Limit value



A D T

EUT TEST CONDITION		MEASUREMENT DETAIL	
CHANNEL	Channel 157	FREQUENCY RANGE	30MHz ~ 1GHz
INPUT POWER	120Vac, 60 Hz	DETECTOR FUNCTION	Peak (PK)
ENVIRONMENTAL CONDITIONS	25deg. C, 65%RH	TESTED BY	Toby Tian

ANTENNA POLARITY & TEST DISTANCE: HORIZONTAL AT 3 M

FREQ. (MHz)	EMISSION LEVEL (dBuV/m)	READ LEVEL (dBuV)	LIMIT (dBuV/m)	MARGIN (dB)	ANTENNA FACTOR (dB/m)	CABLE LOSS (dB)	PREAMP FACTOR (dB)	ANTENNA HEIGHT (cm)	TABLE ANGLE (Degree)	REMARK
141.78	29.87	47.79	43.5	-13.63	12.41	1.3	31.63	113	113	Peak
181.47	26.31	45.95	43.5	-17.19	10.67	1.51	31.82	123	310	Peak
202.8	28.01	48.64	43.5	-15.49	9.48	1.61	31.72	127	94	Peak
650	23.58	32.15	46	-22.42	20.21	3.24	32.02	126	256	Peak
708.8	23.83	31.17	46	-22.17	20.94	3.46	31.74	103	44	Peak
757.1	24.91	31.1	46	-21.09	21.63	3.59	31.41	130	264	Peak

ANTENNA POLARITY & TEST DISTANCE: VERTICAL AT 3 M

FREQ. (MHz)	EMISSION LEVEL (dBuV/m)	READ LEVEL (dBuV)	LIMIT (dBuV/m)	MARGIN (dB)	ANTENNA FACTOR (dB/m)	CABLE LOSS (dB)	PREAMP FACTOR (dB)	ANTENNA HEIGHT (cm)	TABLE ANGLE (Degree)	REMARK
85.89	27.8	50.35	40	-12.2	8.23	1	31.78	102	312	Peak
132.87	26.92	45.59	43.5	-16.58	11.88	1.26	31.81	115	342	Peak
138	25.3	43.5	43.5	-18.2	12.21	1.28	31.69	124	214	Peak
573	22.18	32.27	46	-23.82	18.99	3.01	32.09	135	157	Peak
668.9	23.89	31.96	46	-22.11	20.44	3.31	31.82	101	213	Peak
748	25.18	31.46	46	-20.82	21.49	3.57	31.34	128	258	Peak

REMARKS: Emission Level = Read Level + Antenna Factor + Cable Loss - Preamp Factor

Margin value = Emission level – Limit value



A D T

EUT TEST CONDITION		MEASUREMENT DETAIL	
CHANNEL	Channel 165	FREQUENCY RANGE	30MHz ~ 1GHz
INPUT POWER	120Vac, 60 Hz	DETECTOR FUNCTION	Peak (PK)
ENVIRONMENTAL CONDITIONS	25deg. C, 65%RH	TESTED BY	Toby Tian

ANTENNA POLARITY & TEST DISTANCE: HORIZONTAL AT 3 M										
FREQ. (MHz)	EMISSION LEVEL (dBuV/m)	READ LEVEL (dBuV)	LIMIT (dBuV/m)	MARGIN (dB)	ANTENNA FACTOR (dB/m)	CABLE LOSS (dB)	PREAMP FACTOR (dB)	ANTENNA HEIGHT (cm)	TABLE ANGLE (Degree)	REMARK
133.68	29.55	48.13	43.5	-13.95	11.94	1.26	31.78	137	49	Peak
146.91	25.33	43.01	43.5	-18.17	12.61	1.33	31.62	107	259	Peak
200.91	28.48	49.23	43.5	-15.02	9.4	1.6	31.75	109	92	Peak
650.7	22.98	31.53	46	-23.02	20.22	3.24	32.01	124	251	Peak
705.3	23.71	31.13	46	-22.29	20.89	3.45	31.76	108	240	Peak
776.7	26.75	32.6	46	-19.25	21.9	3.64	31.39	116	343	Peak

ANTENNA POLARITY & TEST DISTANCE: VERTICAL AT 3 M										
FREQ. (MHz)	EMISSION LEVEL (dBuV/m)	READ LEVEL (dBuV)	LIMIT (dBuV/m)	MARGIN (dB)	ANTENNA FACTOR (dB/m)	CABLE LOSS (dB)	PREAMP FACTOR (dB)	ANTENNA HEIGHT (cm)	TABLE ANGLE (Degree)	REMARK
65.91	23.14	42.67	40	-16.86	11.24	0.87	31.64	114	286	Peak
82.92	27.16	49.64	40	-12.84	8.18	0.99	31.65	106	113	Peak
134.22	26.23	44.81	43.5	-17.27	11.94	1.26	31.78	139	37	Peak
657	24.87	33.28	46	-21.13	20.29	3.27	31.97	137	349	Peak
695.5	25.18	32.82	46	-20.82	20.76	3.41	31.81	124	33	Peak
769	25.47	31.37	46	-20.53	21.79	3.62	31.31	138	193	Peak

REMARKS: Emission Level = Read Level + Antenna Factor + Cable Loss - Preamp Factor
 Margin value = Emission level – Limit value

4.2 CONDUCTED EMISSION MEASUREMENT

4.2.1 LIMITS OF CONDUCTED EMISSION MEASUREMENT

FREQUENCY OF EMISSION (MHz)	CONDUCTED LIMIT (dB μ V)	
	Quasi-peak	Average
0.15 ~ 0.5	66 to 56	56 to 46
0.5 ~ 5	56	46
5 ~ 30	60	50

NOTE:

1. The lower limit shall apply at the transition frequencies.
2. The limit decreases in line with the logarithm of the frequency in the range of 0.15 to 0.50MHz.
3. All emanations from a class A/B digital device or system, including any network of conductors and apparatus connected thereto, shall not exceed the level of field strengths specified above.

4.2.2 TEST INSTRUMENTS

DESCRIPTION & MANUFACTURER	MODEL NO.	SERIAL NO.	DATE OF CALIBRATION	DUE DATE OF CALIBRATION
Test Receiver ROHDE & SCHWARZ	ESCI	100613	Nov. 11, 2014	Nov. 10, 2015
RF signal cable Woken	5D-FB	Cable-HYC01-01	Dec. 26, 2014	Dec. 25, 2015
LISN ROHDE & SCHWARZ (EUT)	ESH3-Z5	835239/001	Mar. 02, 2015	Mar. 01, 2016
LISN ROHDE & SCHWARZ (Peripheral)	ESH3-Z5	100311	Jul. 21, 2014	Jul. 20, 2015
Software ADT	BV ADT_Cond_ V7.3.7.3	NA	NA	NA

- NOTE:**
1. The calibration interval of the above test instruments is 12 months and the calibrations are traceable to NML/ROC and NIST/USA.
 2. The test was performed in HwaYa Shielded Room 1.
 3. The VCCI Site Registration No. is C-2047.

4.2.3 TEST PROCEDURES

- a. The EUT was placed 0.4 meters from the conducting wall of the shielded room with EUT being connected to the power mains through a line impedance stabilization network (LISN). Other support units were connected to the power mains through another LISN. The two LISNs provide 50 ohm/ 50uH of coupling impedance for the measuring instrument.
- b. Both lines of the power mains connected to the EUT were checked for maximum conducted interference.
- c. The frequency range from 150kHz to 30MHz was searched. Emission levels under (Limit - 20dB) was not recorded.

NOTE: All modes of operation were investigated and the worst-case emissions are reported.

4.2.4 DEVIATION FROM TEST STANDARD

No deviation.

4.2.5 TEST SETUP

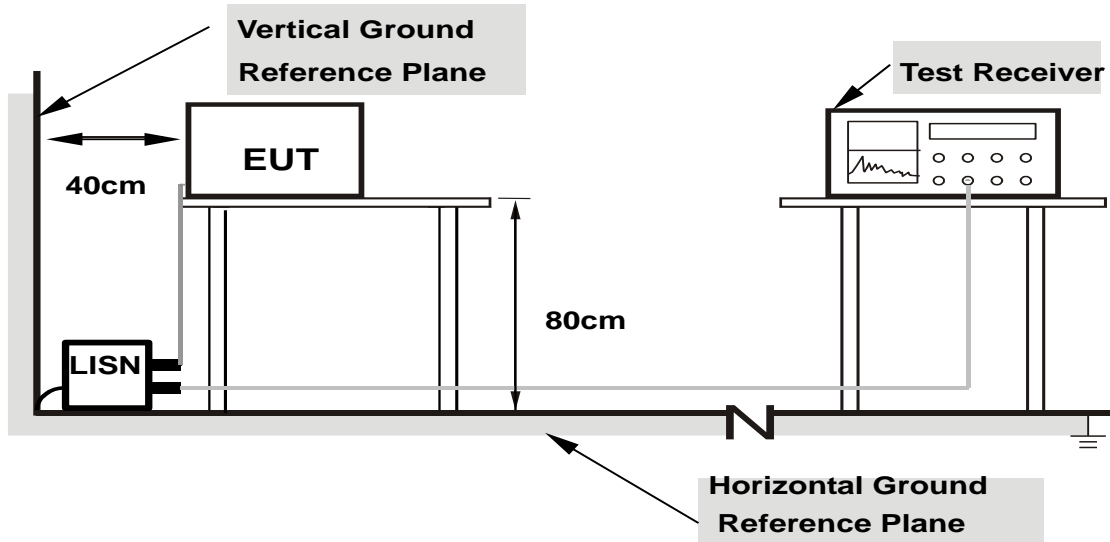

- Note:**
1. Support units were connected to second LISN.
 2. Both of LISNs (AMN) are 80 cm from EUT and at least 80 from other units and other metal planes

For the actual test configuration, please refer to the attached file (Test Setup Photo).

4.2.6 EUT OPERATING CONDITIONS

Same as section 4.1.6.

4.2.7 TEST RESULTS

CONDUCTED WORST-CASE DATA :

Mode A

PHASE	Line 1	6dB BANDWIDTH	9kHz
FUNCTION TYPE	WLAN 5G Tx + Adapter + USB Cable + Earphone		

No	Frequency (MHz)	Correction Factor (dB)	Reading Value (dBuV)		Emission Level (dBuV)		Limit (dBuV)		Margin (dB)	
			Q.P.	AV.	Q.P.	AV.	Q.P.	AV.	Q.P.	AV.
1	0.16569	0.05	45.39	31.28	45.44	31.33	65.17	55.17	-19.73	-23.84
2	0.20838	0.06	42.91	29.73	42.97	29.79	63.27	53.27	-20.30	-23.48
3	0.29429	0.06	40.63	35.15	40.69	35.21	60.40	50.40	-19.71	-15.19
4	0.33484	0.06	41.78	34.89	41.84	34.95	59.33	49.33	-17.49	-14.38
5	0.70395	0.07	37.41	28.80	37.48	28.87	56.00	46.00	-18.52	-17.13
6	1.03757	0.08	38.10	28.75	38.18	28.83	56.00	46.00	-17.82	-17.17

Remarks:

1. Q.P. and AV. are abbreviations of quasi-peak and average individually.
2. The emission levels of other frequencies were very low against the limit.
3. Margin value = Emission level – Limit value
4. Correction factor = Insertion loss + Cable loss
5. Emission Level = Correction Factor + Reading Value

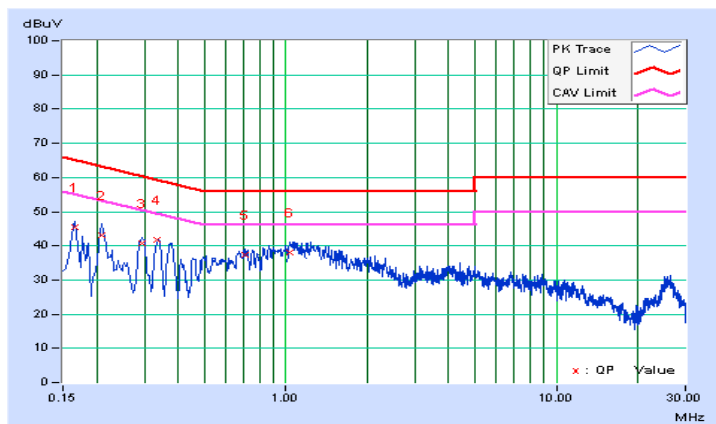

PHASE	Line 2	6dB BANDWIDTH	9kHz
FUNCTION TYPE	WLAN 5G Tx + Adapter + USB Cable + Earphone		

No	Frequency (MHz)	Correction Factor (dB)	Reading Value (dBuV)		Emission Level (dBuV)		Limit (dBuV)		Margin (dB)	
			Q.P.	AV.	Q.P.	AV.	Q.P.	AV.	Q.P.	AV.
1	0.15391	0.05	39.39	28.86	39.44	28.91	65.79	55.79	-26.35	-26.88
2	0.16955	0.05	43.31	31.26	43.36	31.31	64.98	54.98	-21.62	-23.67
3	0.29429	0.05	45.00	39.57	45.05	39.62	60.40	50.40	-15.35	-10.78
4	0.38069	0.06	42.71	35.44	42.77	35.50	58.26	48.26	-15.50	-12.77
5	1.02193	0.08	38.45	28.51	38.53	28.59	56.00	46.00	-17.47	-17.41
6	1.87822	0.11	37.55	29.93	37.66	30.04	56.00	46.00	-18.34	-15.96

Remarks:

1. Q.P. and AV. are abbreviations of quasi-peak and average individually.
2. The emission levels of other frequencies were very low against the limit.
3. Margin value = Emission level – Limit value
4. Correction factor = Insertion loss + Cable loss
5. Emission Level = Correction Factor + Reading Value

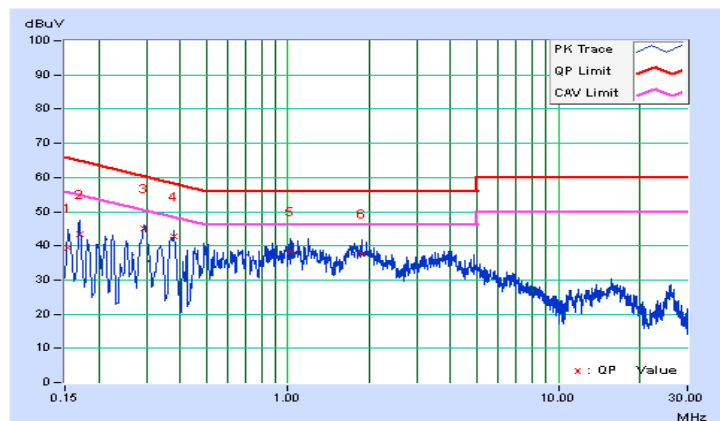



A D T

Mode B

PHASE	Line 1	6dB BANDWIDTH	9kHz
FUNCTION TYPE	WLAN 5G Tx + Adapter + USB Cable + Earphone		

No	Frequency (MHz)	Correction Factor (dB)	Reading Value (dBuV)		Emission Level (dBuV)		Limit (dBuV)		Margin (dB)	
			Q.P.	AV.	Q.P.	AV.	Q.P.	AV.	Q.P.	AV.
1	0.16526	0.05	43.42	32.09	43.47	32.14	65.20	55.20	-21.72	-23.05
2	0.20893	0.06	40.86	30.17	40.92	30.23	63.25	53.25	-22.33	-23.02
3	0.29740	0.06	40.62	31.69	40.68	31.75	60.32	50.32	-19.64	-18.57
4	0.33308	0.06	41.72	35.63	41.78	35.69	59.37	49.37	-17.59	-13.68
5	0.37108	0.06	40.88	36.21	40.94	36.27	58.48	48.48	-17.54	-12.21
6	1.04517	0.08	37.90	27.39	37.98	27.47	56.00	46.00	-18.02	-18.53

Remarks:

1. Q.P. and AV. are abbreviations of quasi-peak and average individually.
2. The emission levels of other frequencies were very low against the limit.
3. Margin value = Emission level – Limit value
4. Correction factor = Insertion loss + Cable loss
5. Emission Level = Correction Factor + Reading Value

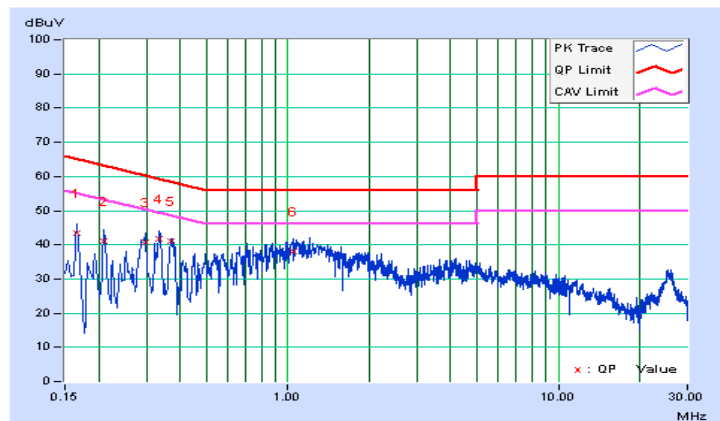

PHASE	Line 2	6dB BANDWIDTH	9kHz
FUNCTION TYPE	WLAN 5G Tx + Adapter + USB Cable + Earphone		

No	Frequency (MHz)	Correction Factor (dB)	Reading Value (dBuV)		Emission Level (dBuV)		Limit (dBuV)		Margin (dB)	
			Q.P.	AV.	Q.P.	AV.	Q.P.	AV.	Q.P.	AV.
1	0.16139	0.05	43.71	32.60	43.76	32.65	65.39	55.39	-21.63	-22.74
2	0.21508	0.05	38.45	25.62	38.50	25.67	63.01	53.01	-24.51	-27.34
3	0.30056	0.06	43.93	31.12	43.99	31.18	60.23	50.23	-16.24	-19.05
4	0.37304	0.06	44.43	40.59	44.49	40.65	58.43	48.43	-13.94	-7.78
5	0.98283	0.08	38.85	30.15	38.93	30.23	56.00	46.00	-17.07	-15.77
6	1.19006	0.09	39.19	30.58	39.28	30.67	56.00	46.00	-16.72	-15.33

Remarks:

1. Q.P. and AV. are abbreviations of quasi-peak and average individually.
2. The emission levels of other frequencies were very low against the limit.
3. Margin value = Emission level – Limit value
4. Correction factor = Insertion loss + Cable loss
5. Emission Level = Correction Factor + Reading Value

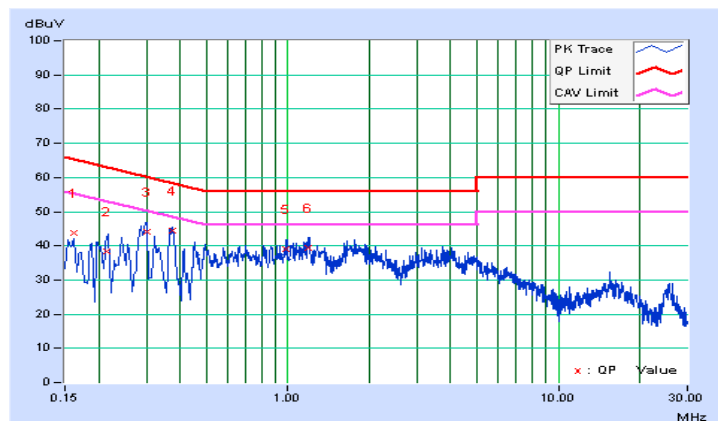

4.3 TRANSMIT POWER MEASUREMENT

4.3.1 LIMITS OF TRANSMIT POWER MEASUREMENT

OPERATION BAND	EUT CATEGORY		LIMIT
U-NII-1		Outdoor Access Point	1 Watt (30 dBm) (Max. e.i.r.p \leq 125mW(21 dBm) at any elevation angle above 30 degrees as measured from the horizon)
		Fixed point-to-point Access Point	1 Watt (30 dBm)
		Indoor Access Point	1 Watt (30 dBm)
	√	Mobile and Portable client device	250mW (24 dBm)
U-NII-2A	√	---	250mW (24 dBm) or 11 dBm+10 log B*
U-NII-2C	√	---	250mW (24 dBm) or 11 dBm+10 log B*
U-NII-3	√	---	1 Watt (30 dBm)

NOTE: Where B is the 26dB emission bandwidth in MHz.

4.3.2 TEST SETUP

FOR POWER OUTPUT MEASUREMENT

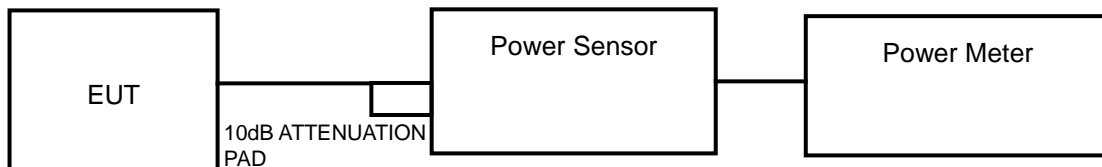

FOR 26dB BANDWIDTH

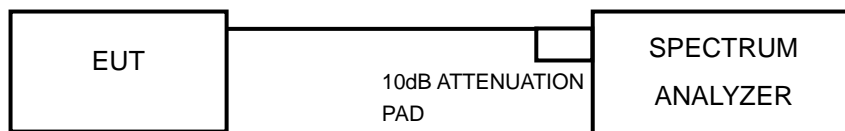

4.3.3 TEST INSTRUMENTS

Refer to section 4.1.3 to get information of above instrument.

4.3.4 TEST PROCEDURE

FOR AVERAGE POWER MEASUREMENT

Method PM is used to perform output power measurement, trigger and gating function of wide band power meter is enabled to measure max output power of TX on burst. Duty factor is not added to measured value.

FOR 26dB BANDWIDTH

- 1) Set RBW = approximately 1% of the emission bandwidth.
- 2) Set the VBW > RBW.
- 3) Detector = Peak.
- 4) Trace mode = max hold.
- 5) Measure the maximum width of the emission that is 26 dB down from the peak of the emission.
Compare this with the RBW setting of the analyzer. Readjust RBW and repeat measurement as needed until the RBW/EBW ratio is approximately 1%.

4.3.5 DEVIATION FROM TEST STANDARD

No deviation.

4.3.6 EUT OPERATING CONDITIONS

The software provided by client to enable the EUT under transmission condition continuously at specific channel frequencies individually.



4.3.7 TEST RESULTS

POWER OUTPUT

Mode A

802.11a _ Ant. A

CHANNEL	FREQUENCY (MHz)	CHAIN	DATA RATE							
			6M bps	9M bps	12M bps	18M bps	24M bps	36M bps	48M bps	54M bps
36	5180	A	15.78	15.76	15.74	15.75	15.71	15.69	15.7	15.72
40	5200	A	17.79	17.78	17.75	17.73	17.76	17.71	17.72	17.7
44	5220	A	17.96	17.95	17.92	17.94	17.88	17.85	17.86	17.84
48	5240	A	17.45	17.42	17.41	17.37	17.38	17.35	17.32	17.36
52	5260	A	18.31	18.24	18.2	18.24	18.23	18.26	18.22	18.14
56	5280	A	18.3	18.26	18.24	18.25	18.23	18.27	18.22	18.21
60	5300	A	18.49	18.48	18.42	18.42	18.35	18.27	18.19	18.18
64	5320	A	16.61	16.53	16.52	16.55	16.4	16.43	16.44	16.43
100	5500	A	16.88	16.86	16.83	16.82	16.79	16.81	16.86	16.85
104	5520	A	16.58	16.55	16.54	16.52	16.57	16.51	16.5	16.46
108	5540	A	16.65	16.61	16.58	16.59	16.57	16.59	16.61	16.62
112	5560	A	16.58	16.57	16.53	16.52	16.48	16.47	16.5	16.51
116	5580	A	16.78	16.75	16.74	16.72	16.73	16.71	16.69	16.7
120	5600	A	16.74	16.73	16.69	16.7	16.68	16.69	16.65	16.66
132	5660	A	16.65	16.63	16.62	16.61	16.58	16.56	16.57	16.55
136	5680	A	16.68	16.67	16.64	16.65	16.62	16.6	16.59	16.56
140	5700	A	15.78	15.77	15.74	15.76	15.72	15.77	15.76	15.75
149	5745	A	16	15.97	15.98	15.95	15.95	15.97	15.91	15.92
153	5765	A	16.94	16.93	16.91	16.9	16.92	16.88	16.86	16.87
157	5785	A	16.98	16.97	16.94	16.92	16.91	16.93	16.92	16.89
161	5805	A	16.97	16.96	16.92	16.9	16.93	16.89	16.88	16.87
165	5825	A	16.98	16.95	16.91	16.94	16.92	16.95	16.92	16.9



A D T

CHANNEL	CHANNEL FREQUENCY (MHz)	MAX. CONDUCTED POWER (mW)	MAX. CONDUCTED POWER (dBm)	POWER LIMIT (dBm)	PASS/FAIL
36	5180	37.84	15.78	24	PASS
40	5200	60.12	17.79	24	PASS
44	5220	62.52	17.96	24	PASS
48	5240	55.59	17.45	24	PASS
52	5260	67.76	18.31	24	PASS
56	5280	67.61	18.3	24	PASS
60	5300	70.63	18.49	24	PASS
64	5320	45.81	16.61	24	PASS
100	5500	48.75	16.88	24	PASS
104	5520	45.50	16.58	24	PASS
108	5540	46.24	16.65	24	PASS
112	5560	45.50	16.58	24	PASS
116	5580	47.64	16.78	24	PASS
120	5600	47.21	16.74	24	PASS
132	5660	46.24	16.65	24	PASS
136	5680	46.56	16.68	24	PASS
140	5700	37.84	15.78	24	PASS
149	5745	39.81	16	30	PASS
153	5765	49.43	16.94	30	PASS
157	5785	49.89	16.98	30	PASS
161	5805	49.77	16.97	30	PASS
165	5825	49.89	16.98	30	PASS

NOTE:

For U-NII-2A, U-NII-2C Band:

1. $11\text{dBm} + 10\log(41.66) = 27.20\text{ dBm} > 24\text{dBm}$.
2. $11\text{dBm} + 10\log(41.98) = 27.23\text{ dBm} > 24\text{dBm}$.
3. $11\text{dBm} + 10\log(37.56) = 26.75\text{ dBm} > 24\text{dBm}$.
4. $11\text{dBm} + 10\log(37.13) = 26.70\text{ dBm} > 24\text{dBm}$.
5. $11\text{dBm} + 10\log(42.13) = 27.25\text{ dBm} > 24\text{dBm}$.
6. $11\text{dBm} + 10\log(43.63) = 27.40\text{ dBm} > 24\text{dBm}$.
7. $11\text{dBm} + 10\log(26.13) = 25.17\text{ dBm} > 24\text{dBm}$.



A D T

802.11n (20MHz)_Ant. A

CHANNEL	FREQUENCY (MHz)	CHAIN	DATA RATE							
			MCS0	MCS1	MCS2	MCS3	MCS4	MCS5	MCS6	MCS7
36	5180	A	15.51	15.47	15.48	15.44	15.43	15.41	15.4	15.39
40	5200	A	17.31	17.29	17.24	17.26	17.2	17.23	17.22	17.19
44	5220	A	17.27	17.24	17.22	17.21	17.19	17.18	17.2	17.17
48	5240	A	17.29	17.26	17.25	17.21	17.24	17.2	17.18	17.17
52	5260	A	17.63	17.62	17.6	17.59	17.54	17.51	17.53	17.55
56	5280	A	17.91	17.87	17.89	17.85	16.84	17.82	17.79	17.8
60	5300	A	17.95	17.93	17.92	17.9	17.87	17.91	17.82	17.91
64	5320	A	16.57	16.46	16.43	16.51	16.46	16.48	16.45	16.55
100	5500	A	16.48	16.38	16.4	16.37	16.42	16.34	16.33	16.43
104	5520	A	16.52	16.33	16.28	16.31	16.29	16.27	16.27	16.24
108	5540	A	16.5	16.49	16.44	16.48	16.41	16.4	16.34	16.39
112	5560	A	16.52	16.48	16.47	16.45	16.44	16.41	16.39	16.4
116	5580	A	16.52	16.42	16.43	16.39	16.4	16.37	16.36	16.33
120	5600	A	16.51	16.41	16.4	16.37	16.4	16.35	16.33	16.32
132	5660	A	16.64	16.61	16.6	16.59	16.53	16.55	16.52	16.53
136	5680	A	16.63	16.59	16.58	16.57	16.55	16.54	16.51	16.5
140	5700	A	14.91	14.7	14.82	14.88	14.81	14.91	14.76	14.88
149	5745	A	15.94	15.87	15.92	15.93	15.86	15.88	15.92	15.83
153	5765	A	16.72	16.7	16.69	16.66	16.71	16.64	16.62	16.6
157	5785	A	16.72	16.68	16.67	16.6	16.7	16.65	16.64	16.62
161	5805	A	16.65	16.63	16.59	16.62	16.58	16.57	16.61	16.59
165	5825	A	16.97	16.96	16.94	16.9	16.92	16.88	16.89	16.85



A D T

CHANNEL	CHANNEL FREQUENCY (MHz)	MAX. CONDUCTED POWER (mW)	MAX. CONDUCTED POWER (dBm)	POWER LIMIT (dBm)	PASS/FAIL
36	5180	35.56	15.51	24	PASS
40	5200	53.83	17.31	24	PASS
44	5220	53.33	17.27	24	PASS
48	5240	53.58	17.29	24	PASS
52	5260	57.94	17.63	24	PASS
56	5280	61.80	17.91	24	PASS
60	5300	62.37	17.95	24	PASS
64	5320	45.39	16.57	24	PASS
100	5500	44.46	16.48	24	PASS
104	5520	44.87	16.52	24	PASS
108	5540	44.67	16.5	24	PASS
112	5560	44.87	16.52	24	PASS
116	5580	44.87	16.52	24	PASS
120	5600	44.77	16.51	24	PASS
132	5660	46.13	16.64	24	PASS
136	5680	46.03	16.63	24	PASS
140	5700	30.97	14.91	24	PASS
149	5745	39.26	15.94	30	PASS
153	5765	46.99	16.72	30	PASS
157	5785	46.99	16.72	30	PASS
161	5805	46.24	16.65	30	PASS
165	5825	49.77	16.97	30	PASS

NOTE:

For U-NII-2A, U-NII-2C Band:

1. $11\text{dBm} + 10\log(40.81) = 27.11\text{ dBm} > 24\text{dBm}$.
2. $11\text{dBm} + 10\log(43.12) = 27.35\text{ dBm} > 24\text{dBm}$.
3. $11\text{dBm} + 10\log(39.34) = 26.95\text{ dBm} > 24\text{dBm}$.
4. $11\text{dBm} + 10\log(38.42) = 26.85\text{ dBm} > 24\text{dBm}$.
5. $11\text{dBm} + 10\log(43.67) = 27.40\text{ dBm} > 24\text{dBm}$.
6. $11\text{dBm} + 10\log(42.21) = 27.25\text{ dBm} > 24\text{dBm}$.
7. $11\text{dBm} + 10\log(27.22) = 25.35\text{ dBm} > 24\text{dBm}$.



A D T

802.11a _ Ant. B

CHANNEL	FREQUENCY (MHz)	CHAIN	DATA RATE							
			6M bps	9M bps	12M bps	18M bps	24M bps	36M bps	48M bps	54M bps
36	5180	B	16.03	15.99	15.89	15.94	15.83	15.81	15.88	15.89
40	5200	B	18.44	18.41	18.4	18.31	18.36	18.34	18.32	18.3
44	5220	B	18.19	18.15	18.14	18.09	18.18	18.14	18.11	18.15
48	5240	B	18.16	18.13	18.12	18.14	18.11	18.09	18.12	18.15
52	5260	B	18.95	18.93	18.92	18.88	18.9	18.86	18.81	18.83
56	5280	B	18.93	18.9	18.92	18.87	18.86	18.83	18.82	18.81
60	5300	B	18.94	18.92	18.93	18.9	18.89	18.9	18.85	18.86
64	5320	B	16.66	16.57	16.62	16.63	16.58	16.57	16.58	16.61
100	5500	B	17.01	16.93	17	16.84	16.95	16.86	16.89	16.88
104	5520	B	18.89	18.87	18.84	18.82	18.79	18.78	18.82	18.77
108	5540	B	18.98	18.94	18.95	18.92	18.9	18.88	18.91	18.86
112	5560	B	18.94	18.93	18.9	18.89	18.91	18.87	18.89	18.91
116	5580	B	19.11	19.03	19.04	19.06	18.97	19.01	18.96	18.97
120	5600	B	19.07	19.06	19.06	19.02	19.04	18.98	18.97	18.95
132	5660	B	19.06	19.03	18.99	18.96	18.95	19.01	19	18.94
136	5680	B	18.84	18.79	18.82	18.81	18.77	18.76	18.76	18.73
140	5700	B	15.9	15.82	15.83	15.81	15.83	15.75	15.82	15.89
149	5745	B	16.02	15.97	15.94	15.93	15.87	15.91	15.85	15.82
153	5765	B	18.34	18.31	18.32	18.3	18.29	18.26	18.27	18.25
157	5785	B	18.64	18.6	18.62	18.59	18.55	18.54	18.57	18.51
161	5805	B	18.34	18.31	18.33	18.27	18.25	18.24	18.17	18.2
165	5825	B	18.54	18.53	18.52	18.49	18.51	18.47	18.5	18.42



A D T

CHANNEL	CHANNEL FREQUENCY (MHz)	MAX. CONDUCTED POWER (mW)	MAX. CONDUCTED POWER (dBm)	POWER LIMIT (dBm)	PASS/FAIL
36	5180	40.09	16.03	24	PASS
40	5200	69.82	18.44	24	PASS
44	5220	65.92	18.19	24	PASS
48	5240	65.46	18.16	24	PASS
52	5260	78.52	18.95	24	PASS
56	5280	78.16	18.93	24	PASS
60	5300	78.34	18.94	24	PASS
64	5320	46.34	16.66	24	PASS
100	5500	50.23	17.01	24	PASS
104	5520	77.45	18.89	24	PASS
108	5540	79.07	18.98	24	PASS
112	5560	78.34	18.94	24	PASS
116	5580	81.47	19.11	24	PASS
120	5600	80.72	19.07	24	PASS
132	5660	80.54	19.06	24	PASS
136	5680	76.56	18.84	24	PASS
140	5700	38.90	15.9	24	PASS
149	5745	39.99	16.02	30	PASS
153	5765	68.23	18.34	30	PASS
157	5785	73.11	18.64	30	PASS
161	5805	68.23	18.34	30	PASS
165	5825	71.45	18.54	30	PASS

NOTE:

For U-NII-2A, U-NII-2C Band:

1. $11\text{dBm} + 10\log(41.66) = 27.20\text{ dBm} > 24\text{dBm}$.
2. $11\text{dBm} + 10\log(41.98) = 27.23\text{ dBm} > 24\text{dBm}$.
3. $11\text{dBm} + 10\log(37.56) = 26.75\text{ dBm} > 24\text{dBm}$.
4. $11\text{dBm} + 10\log(37.13) = 26.70\text{ dBm} > 24\text{dBm}$.
5. $11\text{dBm} + 10\log(42.13) = 27.25\text{ dBm} > 24\text{dBm}$.
6. $11\text{dBm} + 10\log(43.63) = 27.40\text{ dBm} > 24\text{dBm}$.
7. $11\text{dBm} + 10\log(26.13) = 25.17\text{ dBm} > 24\text{dBm}$.



802.11n (20MHz)_Ant. B

CHANNEL	FREQUENCY (MHz)	CHAIN	DATA RATE							
			MCS0	MCS1	MCS2	MCS3	MCS4	MCS5	MCS6	MCS7
36	5180	B	15.93	15.91	15.87	15.9	15.84	15.81	15.85	15.83
40	5200	B	17.74	17.72	17.68	17.66	17.65	17.68	17.64	16.61
44	5220	B	17.76	17.75	17.74	17.7	17.74	17.71	17.73	17.74
48	5240	B	17.74	17.72	17.71	17.7	17.68	17.64	17.63	17.62
52	5260	B	18.15	18.06	18.1	18.08	18.02	18.05	18.11	18.03
56	5280	B	18.13	18.09	18.09	18.11	18.07	18.02	18.01	18
60	5300	B	18.17	18.06	18.1	18.13	18.13	18.07	18.04	18.1
64	5320	B	16.17	16.15	16.13	16.15	16.16	16.11	16.1	16.16
100	5500	B	16.59	16.56	16.51	16.54	16.55	16.48	16.44	16.47
104	5520	B	18.41	18.4	18.37	18.38	18.34	18.32	18.33	18.3
108	5540	B	18.51	18.48	18.46	18.47	18.44	18.43	18.41	18.43
112	5560	B	18.49	18.47	18.46	18.41	18.42	18.39	18.4	18.36
116	5580	B	18.62	18.59	18.6	18.55	18.57	18.54	18.51	18.6
120	5600	B	18.37	18.33	18.32	18.34	18.29	18.25	18.26	18.24
132	5660	B	18.64	18.62	18.61	18.56	18.55	18.52	18.53	18.52
136	5680	B	18.73	18.7	18.67	18.61	18.64	18.62	18.59	18.6
140	5700	B	15.77	15.75	15.69	15.73	15.76	15.74	15.76	15.75
149	5745	B	15.82	15.8	15.77	15.79	15.75	15.71	15.73	15.72
153	5765	B	17.87	17.84	17.83	17.8	17.79	17.81	17.77	17.76
157	5785	B	18.1	18.07	18.06	18.09	18.03	18.08	18.06	18.06
161	5805	B	18.01	17.99	17.98	17.94	17.95	17.91	17.94	17.92
165	5825	B	18.08	18.04	18.01	17.97	18.02	17.96	17.95	17.97



A D T

CHANNEL	CHANNEL FREQUENCY (MHz)	MAX. CONDUCTED POWER (mW)	MAX. CONDUCTED POWER (dBm)	POWER LIMIT (dBm)	PASS/FAIL
36	5180	39.17	15.93	24	PASS
40	5200	59.43	17.74	24	PASS
44	5220	59.70	17.76	24	PASS
48	5240	59.43	17.74	24	PASS
52	5260	65.31	18.15	24	PASS
56	5280	65.01	18.13	24	PASS
60	5300	65.61	18.17	24	PASS
64	5320	41.40	16.17	24	PASS
100	5500	45.60	16.59	24	PASS
104	5520	69.34	18.41	24	PASS
108	5540	70.96	18.51	24	PASS
112	5560	70.63	18.49	24	PASS
116	5580	72.78	18.62	24	PASS
120	5600	68.71	18.37	24	PASS
132	5660	73.11	18.64	24	PASS
136	5680	74.64	18.73	24	PASS
140	5700	37.76	15.77	24	PASS
149	5745	38.19	15.82	30	PASS
153	5765	61.24	17.87	30	PASS
157	5785	64.57	18.1	30	PASS
161	5805	63.24	18.01	30	PASS
165	5825	64.27	18.08	30	PASS

NOTE:

For U-NII-2A, U-NII-2C Band:

1. $11\text{dBm} + 10\log(40.81) = 27.11\text{ dBm} > 24\text{dBm}$.
2. $11\text{dBm} + 10\log(43.12) = 27.35\text{ dBm} > 24\text{dBm}$.
3. $11\text{dBm} + 10\log(39.34) = 26.95\text{ dBm} > 24\text{dBm}$.
4. $11\text{dBm} + 10\log(38.42) = 26.85\text{ dBm} > 24\text{dBm}$.
5. $11\text{dBm} + 10\log(43.67) = 27.40\text{ dBm} > 24\text{dBm}$.
6. $11\text{dBm} + 10\log(42.21) = 27.25\text{ dBm} > 24\text{dBm}$.
7. $11\text{dBm} + 10\log(27.22) = 25.35\text{ dBm} > 24\text{dBm}$.



Mode B

802.11a _ Ant. A

CHANNEL	FREQUENCY (MHz)	CHAIN	DATA RATE							
			6M bps	9M bps	12M bps	18M bps	24M bps	36M bps	48M bps	54M bps
36	5180	A	16.33	16.3	16.28	16.24	16.31	16.22	16.25	16.23
40	5200	A	18.04	18.01	17.96	18.02	17.95	17.93	17.94	17.96
44	5220	A	18.14	18.11	18.09	18.12	18.1	18.04	18.09	18.06
48	5240	A	18.03	17.98	17.99	18.01	17.97	17.96	17.97	17.92
52	5260	A	18.31	18.24	18.2	18.24	18.23	18.26	18.22	18.14
56	5280	A	18.3	18.26	18.24	18.25	18.23	18.27	18.22	18.21
60	5300	A	18.49	18.48	18.42	18.42	18.35	18.27	18.19	18.18
64	5320	A	16.94	16.91	16.84	16.9	16.83	16.81	16.89	16.81
100	5500	A	16.88	16.86	16.83	16.82	16.79	16.81	16.86	16.85
104	5520	A	16.58	16.55	16.54	16.52	16.57	16.51	16.5	16.46
108	5540	A	16.65	16.61	16.58	16.59	16.57	16.59	16.61	16.62
112	5560	A	16.58	16.57	16.53	16.52	16.48	16.47	16.5	16.51
116	5580	A	16.78	16.75	16.74	16.72	16.73	16.71	16.69	16.7
120	5600	A	16.74	16.73	16.69	16.7	16.68	16.69	16.65	16.66
132	5660	A	16.65	16.63	16.62	16.61	16.58	16.56	16.57	16.55
136	5680	A	16.68	16.67	16.64	16.65	16.62	16.6	16.59	16.56
140	5700	A	15.78	15.77	15.74	15.76	15.72	15.77	15.76	15.75
149	5745	A	16	15.97	15.98	15.95	15.95	15.97	15.91	15.92
153	5765	A	16.94	16.93	16.91	16.9	16.92	16.88	16.86	16.87
157	5785	A	16.98	16.97	16.94	16.92	16.91	16.93	16.92	16.89
161	5805	A	16.97	16.96	16.92	16.9	16.93	16.89	16.88	16.87
165	5825	A	16.98	16.95	16.91	16.94	16.92	16.95	16.92	16.9



A D T

CHANNEL	CHANNEL FREQUENCY (MHz)	MAX. CONDUCTED POWER (mW)	MAX. CONDUCTED POWER (dBm)	POWER LIMIT (dBm)	PASS/FAIL
36	5180	42.95	16.33	24	PASS
40	5200	63.68	18.04	24	PASS
44	5220	65.16	18.14	24	PASS
48	5240	63.53	18.03	24	PASS
52	5260	67.76	18.31	24	PASS
56	5280	67.61	18.3	24	PASS
60	5300	70.63	18.49	24	PASS
64	5320	49.43	16.94	24	PASS
100	5500	48.75	16.88	24	PASS
104	5520	45.50	16.58	24	PASS
108	5540	46.24	16.65	24	PASS
112	5560	45.50	16.58	24	PASS
116	5580	47.64	16.78	24	PASS
120	5600	47.21	16.74	24	PASS
132	5660	46.24	16.65	24	PASS
136	5680	46.56	16.68	24	PASS
140	5700	37.84	15.78	24	PASS
149	5745	39.81	16	30	PASS
153	5765	49.43	16.94	30	PASS
157	5785	49.89	16.98	30	PASS
161	5805	49.77	16.97	30	PASS
165	5825	49.89	16.98	30	PASS

NOTE:

For U-NII-2A, U-NII-2C Band:

1. $11\text{dBm} + 10\log(41.66) = 27.20\text{ dBm} > 24\text{dBm}$.
2. $11\text{dBm} + 10\log(41.98) = 27.23\text{ dBm} > 24\text{dBm}$.
3. $11\text{dBm} + 10\log(37.56) = 26.75\text{ dBm} > 24\text{dBm}$.
4. $11\text{dBm} + 10\log(37.13) = 26.70\text{ dBm} > 24\text{dBm}$.
5. $11\text{dBm} + 10\log(42.13) = 27.25\text{ dBm} > 24\text{dBm}$.
6. $11\text{dBm} + 10\log(43.63) = 27.40\text{ dBm} > 24\text{dBm}$.
7. $11\text{dBm} + 10\log(26.13) = 25.17\text{ dBm} > 24\text{dBm}$.



A D T

802.11n (20MHz)_Ant. A

CHANNEL	FREQUENCY (MHz)	CHAIN	DATA RATE							
			MCS0	MCS1	MCS2	MCS3	MCS4	MCS5	MCS6	MCS7
36	5180	A	16.19	16.14	16.12	16.11	16.09	16.12	16.05	16.02
40	5200	A	18	17.96	17.95	17.92	17.93	17.89	17.88	17.9
44	5220	A	17.92	17.87	17.85	17.86	17.83	17.81	17.82	17.85
48	5240	A	17.99	17.96	17.84	17.95	17.97	17.87	17.87	17.96
52	5260	A	17.63	17.62	17.6	17.59	17.54	17.51	17.53	17.55
56	5280	A	17.91	17.87	17.89	17.85	16.84	17.82	17.79	17.8
60	5300	A	17.95	17.93	17.92	17.9	17.87	17.91	17.82	17.86
64	5320	A	16.82	16.78	16.81	16.8	16.81	16.8	16.73	16.79
100	5500	A	15.94	15.88	15.9	15.87	15.91	15.82	15.8	15.93
104	5520	A	16.52	16.33	16.28	16.31	16.29	16.27	16.27	16.24
108	5540	A	16.5	16.49	16.44	16.48	16.41	16.4	16.34	16.39
112	5560	A	16.52	16.48	16.47	16.45	16.44	16.41	16.39	16.4
116	5580	A	16.51	16.42	16.43	16.39	16.4	16.37	16.36	16.33
120	5600	A	16.5	16.41	16.4	16.37	16.4	16.35	16.33	16.32
132	5660	A	16.64	16.61	16.6	16.59	16.53	16.55	16.52	16.53
136	5680	A	16.63	16.59	16.58	16.57	16.55	16.54	16.51	16.5
140	5700	A	14.9	14.87	14.86	14.79	14.86	14.84	14.81	14.85
149	5745	A	15.94	15.87	15.92	15.93	15.86	15.88	15.92	15.83
153	5765	A	16.72	16.7	16.69	16.66	16.71	16.64	16.62	16.6
157	5785	A	16.72	16.68	16.67	16.6	16.7	16.65	16.64	16.62
161	5805	A	16.65	16.63	16.59	16.62	16.58	16.57	16.61	16.59
165	5825	A	16.97	16.96	16.94	16.9	16.92	16.88	16.89	16.85



A D T

CHANNEL	CHANNEL FREQUENCY (MHz)	MAX. CONDUCTED POWER (mW)	MAX. CONDUCTED POWER (dBm)	POWER LIMIT (dBm)	PASS/FAIL
36	5180	41.59	16.19	24	PASS
40	5200	63.10	18	24	PASS
44	5220	61.94	17.92	24	PASS
48	5240	62.95	17.99	24	PASS
52	5260	57.94	17.63	24	PASS
56	5280	61.80	17.91	24	PASS
60	5300	62.37	17.95	24	PASS
64	5320	48.08	16.82	24	PASS
100	5500	39.26	15.94	24	PASS
104	5520	44.87	16.52	24	PASS
108	5540	44.67	16.5	24	PASS
112	5560	44.87	16.52	24	PASS
116	5580	44.77	16.51	24	PASS
120	5600	44.67	16.5	24	PASS
132	5660	46.13	16.64	24	PASS
136	5680	46.03	16.63	24	PASS
140	5700	30.90	14.9	24	PASS
149	5745	39.26	15.94	30	PASS
153	5765	46.99	16.72	30	PASS
157	5785	46.99	16.72	30	PASS
161	5805	46.24	16.65	30	PASS
165	5825	49.77	16.97	30	PASS

NOTE:

For U-NII-2A, U-NII-2C Band:

1. $11\text{dBm} + 10\log(40.81) = 27.11\text{ dBm} > 24\text{dBm}$.
2. $11\text{dBm} + 10\log(43.12) = 27.35\text{ dBm} > 24\text{dBm}$.
3. $11\text{dBm} + 10\log(39.34) = 26.95\text{ dBm} > 24\text{dBm}$.
4. $11\text{dBm} + 10\log(38.42) = 26.85\text{ dBm} > 24\text{dBm}$.
5. $11\text{dBm} + 10\log(43.67) = 27.40\text{ dBm} > 24\text{dBm}$.
6. $11\text{dBm} + 10\log(42.21) = 27.25\text{ dBm} > 24\text{dBm}$.
7. $11\text{dBm} + 10\log(27.22) = 25.35\text{ dBm} > 24\text{dBm}$.



A D T

802.11a _ Ant. B

CHANNEL	FREQUENCY (MHz)	CHAIN	DATA RATE							
			6M bps	9M bps	12M bps	18M bps	24M bps	36M bps	48M bps	54M bps
36	5180	B	16.63	16.6	16.57	16.56	16.54	16.58	16.51	16.52
40	5200	B	18.44	18.41	18.4	18.31	18.36	18.34	18.32	18.3
44	5220	B	18.19	18.15	18.14	18.09	18.18	18.14	18.11	18.15
48	5240	B	18.16	18.13	18.12	18.14	18.11	18.09	18.12	18.15
52	5260	B	18.95	18.93	18.92	18.88	18.9	18.86	18.81	18.83
56	5280	B	18.93	18.9	18.92	18.87	18.86	18.83	18.82	18.81
60	5300	B	18.94	18.92	18.93	18.9	18.89	18.9	18.85	18.86
64	5320	B	17.55	17.47	17.41	17.51	17.46	17.47	17.51	17.46
100	5500	B	17.01	16.93	17	16.84	16.95	16.86	16.89	16.88
104	5520	B	18.89	18.87	18.84	18.82	18.79	18.78	18.82	18.77
108	5540	B	18.98	18.94	18.95	18.92	18.9	18.88	18.91	18.86
112	5560	B	18.94	18.93	18.9	18.89	18.91	18.87	18.89	18.91
116	5580	B	19.11	19.03	19.04	19.06	18.97	19.01	18.96	18.97
120	5600	B	19.07	19.06	19.06	19.02	19.04	18.98	18.97	18.95
132	5660	B	19.06	19.03	18.99	18.96	18.95	19.01	19	18.94
136	5680	B	18.84	18.79	18.82	18.81	18.77	18.76	18.76	18.73
140	5700	B	15.81	15.79	15.8	15.78	15.75	15.79	15.79	15.73
149	5745	B	16.02	15.97	15.94	15.93	15.87	15.91	15.85	15.82
153	5765	B	18.34	18.31	18.32	18.3	18.29	18.26	18.27	18.25
157	5785	B	18.64	18.6	18.62	18.59	18.55	18.54	18.57	18.51
161	5805	B	18.34	18.31	18.33	18.27	18.25	18.24	18.17	18.2
165	5825	B	18.54	18.53	18.52	18.49	18.51	18.47	18.5	18.42



A D T

CHANNEL	CHANNEL FREQUENCY (MHz)	MAX. CONDUCTED POWER (mW)	MAX. CONDUCTED POWER (dBm)	POWER LIMIT (dBm)	PASS/FAIL
36	5180	46.03	16.63	24	PASS
40	5200	69.82	18.44	24	PASS
44	5220	65.92	18.19	24	PASS
48	5240	65.46	18.16	24	PASS
52	5260	78.52	18.95	24	PASS
56	5280	78.16	18.93	24	PASS
60	5300	78.34	18.94	24	PASS
64	5320	56.89	17.55	24	PASS
100	5500	50.23	17.01	24	PASS
104	5520	77.45	18.89	24	PASS
108	5540	79.07	18.98	24	PASS
112	5560	78.34	18.94	24	PASS
116	5580	81.47	19.11	24	PASS
120	5600	80.72	19.07	24	PASS
132	5660	80.54	19.06	24	PASS
136	5680	76.56	18.84	24	PASS
140	5700	38.11	15.81	24	PASS
149	5745	39.99	16.02	30	PASS
153	5765	68.23	18.34	30	PASS
157	5785	73.11	18.64	30	PASS
161	5805	68.23	18.34	30	PASS
165	5825	71.45	18.54	30	PASS

NOTE:

For U-NII-2A, U-NII-2C Band:

1. $11\text{dBm} + 10\log(41.66) = 27.20\text{ dBm} > 24\text{dBm}$.
2. $11\text{dBm} + 10\log(41.98) = 27.23\text{ dBm} > 24\text{dBm}$.
3. $11\text{dBm} + 10\log(37.56) = 26.75\text{ dBm} > 24\text{dBm}$.
4. $11\text{dBm} + 10\log(37.13) = 26.70\text{ dBm} > 24\text{dBm}$.
5. $11\text{dBm} + 10\log(42.13) = 27.25\text{ dBm} > 24\text{dBm}$.
6. $11\text{dBm} + 10\log(43.63) = 27.40\text{ dBm} > 24\text{dBm}$.
7. $11\text{dBm} + 10\log(26.13) = 25.17\text{ dBm} > 24\text{dBm}$.



802.11n (20MHz)_Ant. B

CHANNEL	FREQUENCY (MHz)	CHAIN	DATA RATE							
			MCS0	MCS1	MCS2	MCS3	MCS4	MCS5	MCS6	MCS7
36	5180	B	16.07	16.01	15.97	16.02	15.96	15.98	15.93	15.92
40	5200	B	17.74	17.72	17.68	17.66	17.65	17.68	17.64	16.61
44	5220	B	17.76	17.75	17.74	17.7	17.74	17.71	17.73	17.74
48	5240	B	17.74	17.72	17.71	17.7	17.68	17.64	17.63	17.62
52	5260	B	18.15	18.06	18.1	18.08	18.02	18.05	18.11	18.03
56	5280	B	18.13	18.11	18.12	18.09	18.04	18.05	18.1	18.04
60	5300	B	18.17	18.06	18.1	18.13	18.13	18.07	18.04	18.1
64	5320	B	17.03	16.92	16.98	16.98	16.99	16.87	17.01	17.01
100	5500	B	17.3	17.26	17.21	17.28	17.25	17.24	17.22	17.27
104	5520	B	18.41	18.4	18.37	18.38	18.34	18.32	18.33	18.3
108	5540	B	18.51	18.48	18.46	18.47	18.44	18.43	18.41	18.43
112	5560	B	18.49	18.47	18.46	18.41	18.42	18.39	18.4	18.36
116	5580	B	18.62	18.59	18.6	18.55	18.57	18.54	18.51	18.6
120	5600	B	18.37	18.33	18.32	18.34	18.29	18.25	18.26	18.24
132	5660	B	18.64	18.62	18.61	18.56	18.55	18.52	18.53	18.52
136	5680	B	18.73	18.7	18.67	18.61	18.64	18.62	18.59	18.6
140	5700	B	15.75	15.69	15.71	15.74	15.7	15.73	15.7	15.72
149	5745	B	15.82	15.8	15.77	15.79	15.75	15.71	15.73	15.72
153	5765	B	17.87	17.84	17.83	17.8	17.79	17.81	17.77	17.76
157	5785	B	18.1	18.07	18.06	18.09	18.03	18.08	18.06	18.06
161	5805	B	18.01	17.99	17.98	17.94	17.95	17.91	17.94	17.92
165	5825	B	18.08	18.04	18.01	17.97	18.02	17.96	17.95	17.97



A D T

CHANNEL	CHANNEL FREQUENCY (MHz)	MAX. CONDUCTED POWER (Mw)	MAX. CONDUCTED POWER (dBm)	POWER LIMIT (dBm)	PASS/FAIL
36	5180	40.46	16.07	24	PASS
40	5200	59.43	17.74	24	PASS
44	5220	59.70	17.76	24	PASS
48	5240	59.43	17.74	24	PASS
52	5260	65.31	18.15	24	PASS
56	5280	65.01	18.13	24	PASS
60	5300	65.61	18.17	24	PASS
64	5320	50.47	17.03	24	PASS
100	5500	53.70	17.3	24	PASS
104	5520	69.34	18.41	24	PASS
108	5540	70.96	18.51	24	PASS
112	5560	70.63	18.49	24	PASS
116	5580	72.78	18.62	24	PASS
120	5600	68.71	18.37	24	PASS
132	5660	73.11	18.64	24	PASS
136	5680	74.64	18.73	24	PASS
140	5700	37.58	15.75	24	PASS
149	5745	38.19	15.82	30	PASS
153	5765	61.24	17.87	30	PASS
157	5785	64.57	18.1	30	PASS
161	5805	63.24	18.01	30	PASS
165	5825	64.27	18.08	30	PASS

NOTE:

For U-NII-2A, U-NII-2C Band:

1. $11\text{dBm} + 10\log(40.81) = 27.11\text{ dBm} > 24\text{dBm}$.
2. $11\text{dBm} + 10\log(43.12) = 27.35\text{ dBm} > 24\text{dBm}$.
3. $11\text{dBm} + 10\log(39.34) = 26.95\text{ dBm} > 24\text{dBm}$.
4. $11\text{dBm} + 10\log(38.42) = 26.85\text{ dBm} > 24\text{dBm}$.
5. $11\text{dBm} + 10\log(43.67) = 27.40\text{ dBm} > 24\text{dBm}$.
6. $11\text{dBm} + 10\log(42.21) = 27.25\text{ dBm} > 24\text{dBm}$.
7. $11\text{dBm} + 10\log(27.22) = 25.35\text{ dBm} > 24\text{dBm}$.



A D T

26dB BANDWIDTH

Mode A

802.11a

CHANNEL	CHANNEL FREQUENCY (MHz)	26dBc BANDWIDTH (MHz)	PASS / FAIL
52	5260	41.66	PASS
60	5300	41.98	PASS
64	5320	37.56	PASS
100	5500	37.13	PASS
116	5580	42.13	PASS
120	5600	43.63	PASS
140	5700	26.13	PASS

802.11n (20MHz)

CHANNEL	CHANNEL FREQUENCY (MHz)	26dBc BANDWIDTH (MHz)	PASS / FAIL
52	5260	40.81	PASS
60	5300	43.12	PASS
64	5320	39.34	PASS
100	5500	38.42	PASS
116	5580	43.67	PASS
120	5600	42.21	PASS
140	5700	27.22	PASS

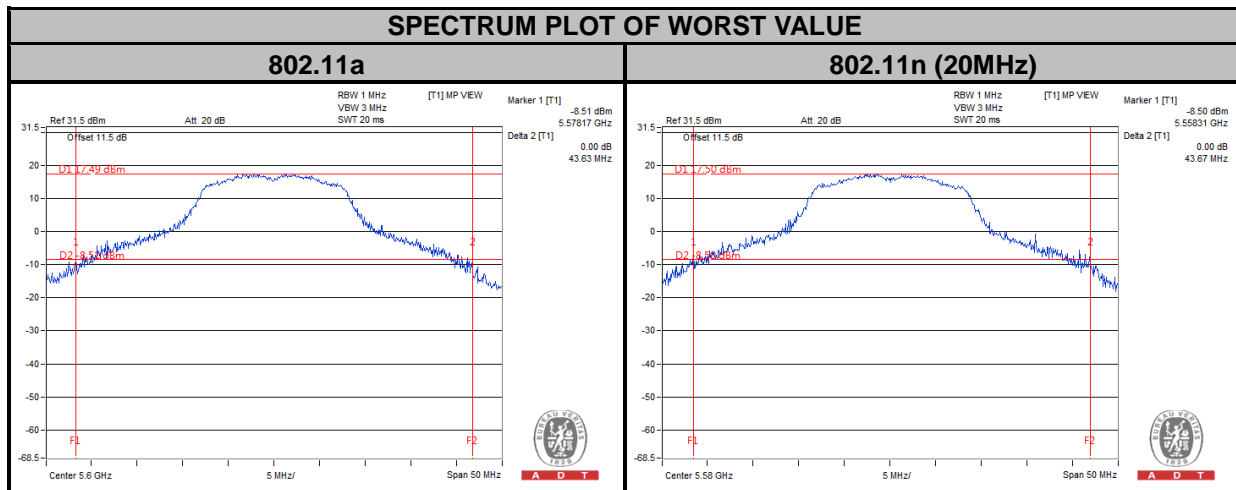



A D T

Mode B

802.11a

CHANNEL	CHANNEL FREQUENCY (MHz)	26dBc BANDWIDTH (MHz)	PASS / FAIL
52	5260	41.66	PASS
60	5300	41.98	PASS
64	5320	37.56	PASS
100	5500	37.13	PASS
116	5580	42.13	PASS
120	5600	43.63	PASS
140	5700	26.13	PASS

802.11n (20MHz)

CHANNEL	CHANNEL FREQUENCY (MHz)	26dBc BANDWIDTH (MHz)	PASS / FAIL
52	5260	40.81	PASS
60	5300	43.12	PASS
64	5320	39.34	PASS
100	5500	38.42	PASS
116	5580	43.67	PASS
120	5600	42.21	PASS
140	5700	27.22	PASS

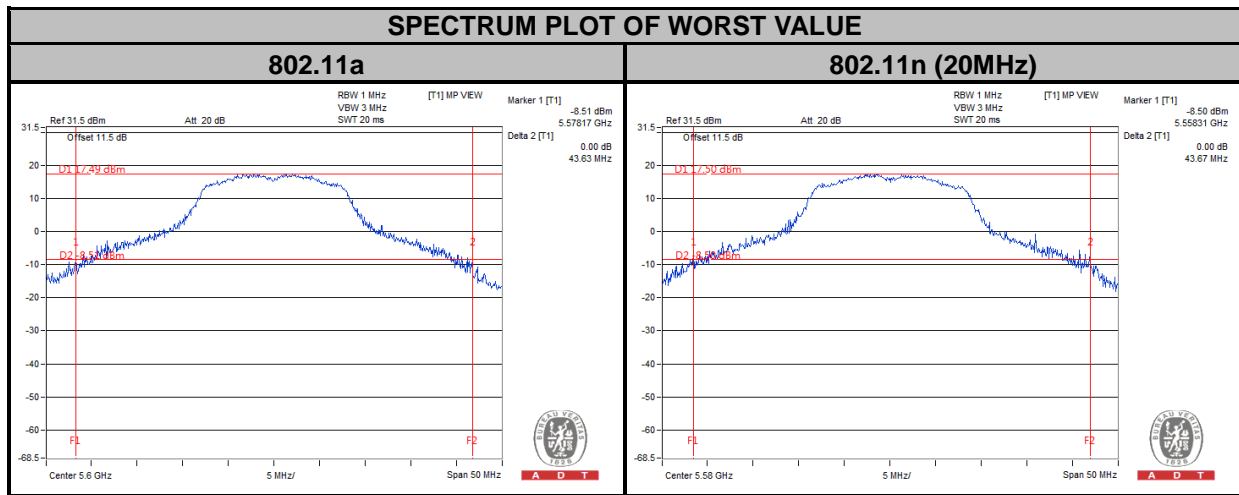

4.4 PEAK POWER SPECTRAL DENSITY MEASUREMENT

4.4.1 LIMITS OF PEAK POWER SPECTRAL DENSITY MEASUREMENT

Operation Band	EUT Category		LIMIT
U-NII-1		Outdoor Access Point	17dBm/ MHz
		Fixed point-to-point Access Point	
		Indoor Access Point	
	√	Mobile and Portable client device	11dBm/ MHz
U-NII-2A	√	---	11dBm/ MHz
U-NII-2C	√	---	11dBm/ MHz
U-NII-3	√	---	30dBm/ 500kHz

4.4.2 TEST SETUP

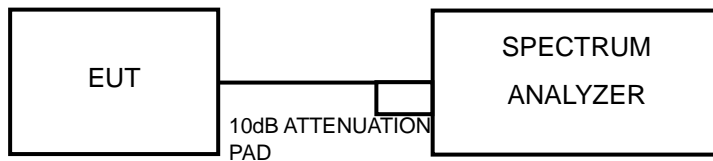

4.4.3 TEST INSTRUMENTS

Refer to section 4.1.3 to get information of above instrument.

4.4.4 TEST PROCEDURES

For U-NII-1, U-NII-2A, U-NII-2C band:

Using method SA-1

- 1) Set span to encompass the entire emission bandwidth (EBW) of the signal.
- 2) Set RBW = 30 kHz, Set VBW ≥ 1 MHz, Detector = RMS
- 3) Set Channel power measure = 1MHz
- 4) Sweep time = auto, trigger set to “free run”.
- 5) Trace average at least 100 traces in power averaging mode.
- 6) Record the max value



A D T

For U-NII-3 band:

- 1) Set span to encompass the entire emission bandwidth (EBW) of the signal.
- 2) Set RBW = 500 kHz, Set VBW \geq 3 RBW, Detector = RMS
- 3) Sweep time = auto, trigger set to “free run”.
- 4) Trace average at least 100 traces in power averaging mode.
- 5) Record the max value and add 10 log (1/duty cycle)

4.4.5 DEVIATION FROM TEST STANDARD

No deviation.

4.4.6 EUT OPERATING CONDITIONS

Same as Item 4.3.6.

4.4.7 TEST RESULTS

Mode A

For U-NII-1, U-NII-2A, U-NII-2C Band

802.11a

CHANNEL	FREQUENCY (MHz)	PSD (dBm)	MAXIMUM LIMIT (dBm)	PASS/FAIL
36	5180	4.55	11	PASS
44	5220	6.67	11	PASS
48	5240	6.71	11	PASS
52	5260	7.85	11	PASS
60	5300	8.30	11	PASS
64	5320	6.44	11	PASS
100	5500	7.09	11	PASS
116	5580	8.80	11	PASS
120	5600	8.36	11	PASS
140	5700	4.88	11	PASS

802.11n (20MHz)

CHANNEL	FREQUENCY (MHz)	PSD (dBm)	MAXIMUM LIMIT (dBm)	PASS/FAIL
36	5180	4.27	11	PASS
44	5220	7.30	11	PASS
48	5240	5.99	11	PASS
52	5260	6.90	11	PASS
60	5300	7.25	11	PASS
64	5320	5.61	11	PASS
100	5500	6.35	11	PASS
116	5580	8.22	11	PASS
120	5600	7.30	11	PASS
140	5700	4.48	11	PASS



A D T

SPECTRUM PLOT OF WORST VALUE

802.11a

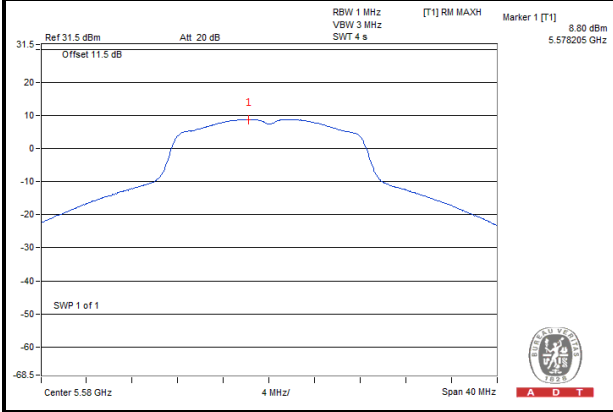

A D T

802.11n (20MHz)

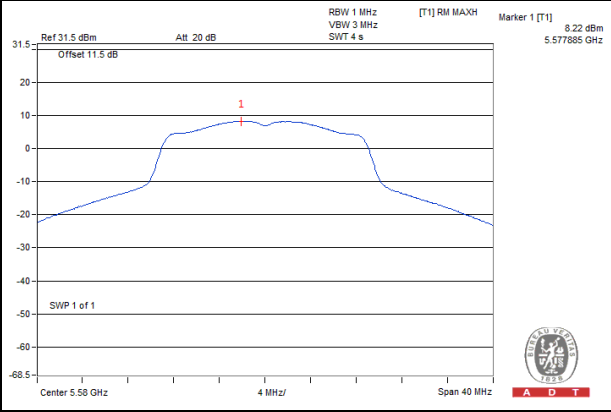

A D T



A D T

For U-NII-3 Band

802.11a

CHANNEL	FREQUENCY (MHz)	PSD (dBm/500kHz)	LIMIT (dBm/500kHz)	PASS / FAIL
149	5745	1.39	30	PASS
157	5785	3.93	30	PASS
165	5825	4.49	30	PASS

802.11n (20MHz)

CHANNEL	FREQUENCY (MHz)	PSD (dBm/500kHz)	LIMIT (dBm/500kHz)	PASS / FAIL
149	5745	0.94	30	PASS
157	5785	3.19	30	PASS
165	5825	3.66	30	PASS

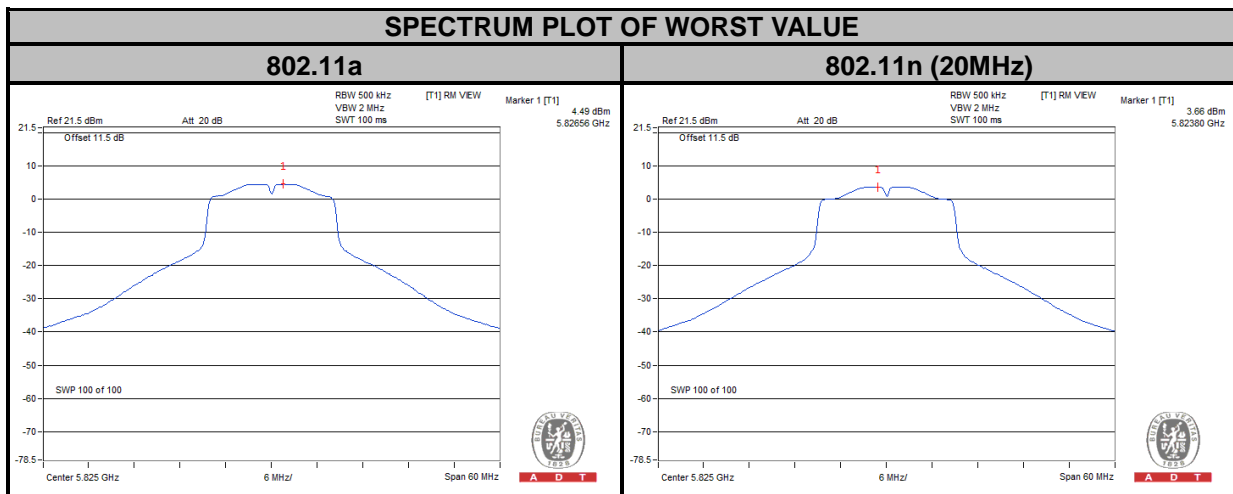



A D T

Mode B

For U-NII-1, U-NII-2A, U-NII-2C Band

802.11a

CHANNEL	FREQUENCY (MHz)	PSD (dBm)	MAXIMUM LIMIT (dBm)	PASS/FAIL
36	5180	5.27	11	PASS
44	5220	6.67	11	PASS
48	5240	6.71	11	PASS
52	5260	7.85	11	PASS
60	5300	8.30	11	PASS
64	5320	6.89	11	PASS
100	5500	7.09	11	PASS
116	5580	8.80	11	PASS
120	5600	8.21	11	PASS
140	5700	4.88	11	PASS

802.11n (20MHz)

CHANNEL	FREQUENCY (MHz)	PSD (dBm)	MAXIMUM LIMIT (dBm)	PASS/FAIL
36	5180	4.61	11	PASS
44	5220	7.30	11	PASS
48	5240	5.99	11	PASS
52	5260	6.90	11	PASS
60	5300	7.25	11	PASS
64	5320	6.09	11	PASS
100	5500	7.32	11	PASS
116	5580	8.22	11	PASS
120	5600	7.30	11	PASS
140	5700	4.48	11	PASS



A D T

SPECTRUM PLOT OF WORST VALUE

802.11a

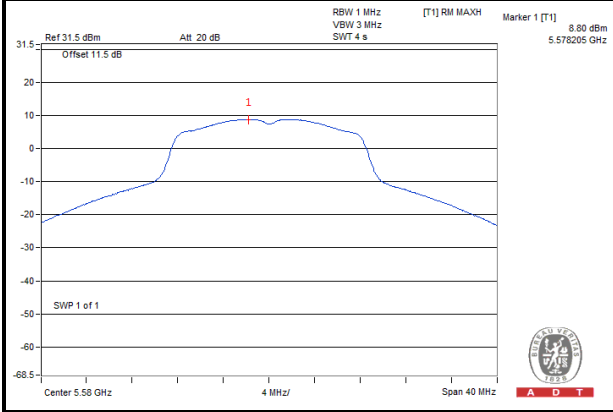

802.11n (20MHz)

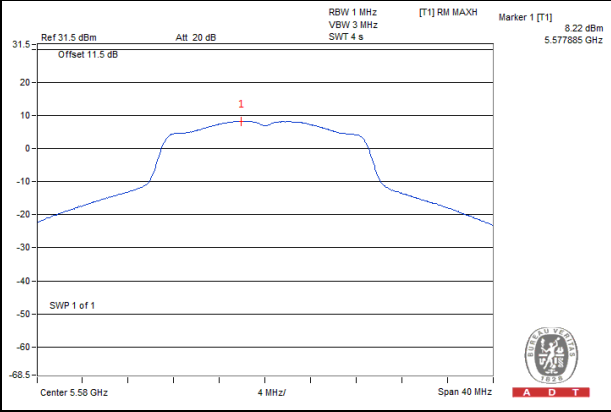



A D T

For U-NII-3 Band

802.11a

CHANNEL	FREQUENCY (MHz)	PSD (dBm/500kHz)	LIMIT (dBm/500kHz)	PASS / FAIL
149	5745	1.39	30	PASS
157	5785	3.93	30	PASS
165	5825	4.49	30	PASS

802.11n (20MHz)

CHANNEL	FREQUENCY (MHz)	PSD (dBm/500kHz)	LIMIT (dBm/500kHz)	PASS / FAIL
149	5745	0.94	30	PASS
157	5785	3.19	30	PASS
165	5825	3.66	30	PASS

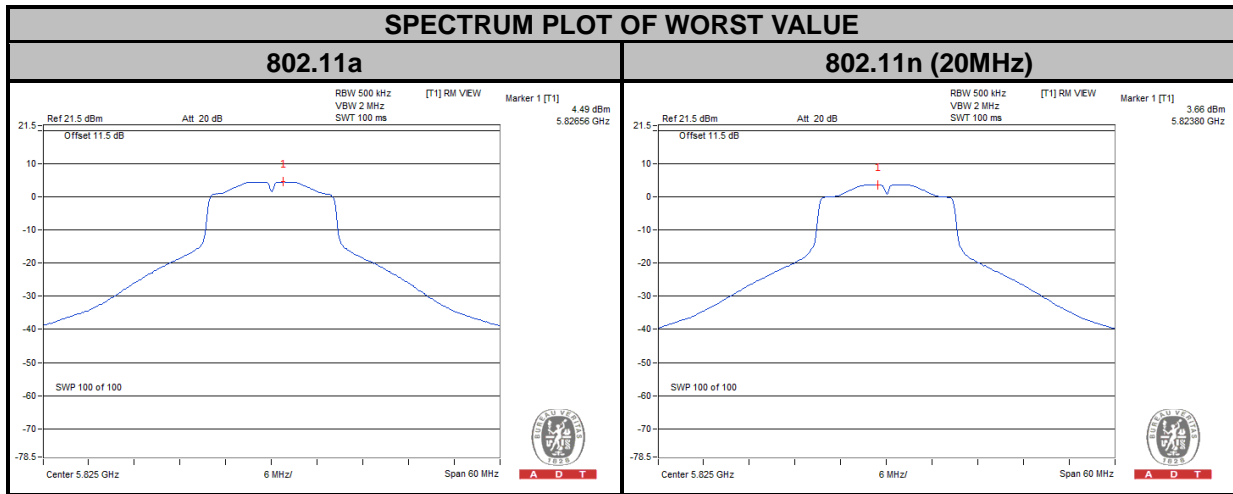

4.5 FREQUENCY STABILITY

4.5.1 LIMITS OF FREQUENCY STABILITY MEASUREMENT

The frequency of the carrier signal shall be maintained within band of operation.

4.5.2 TEST SETUP

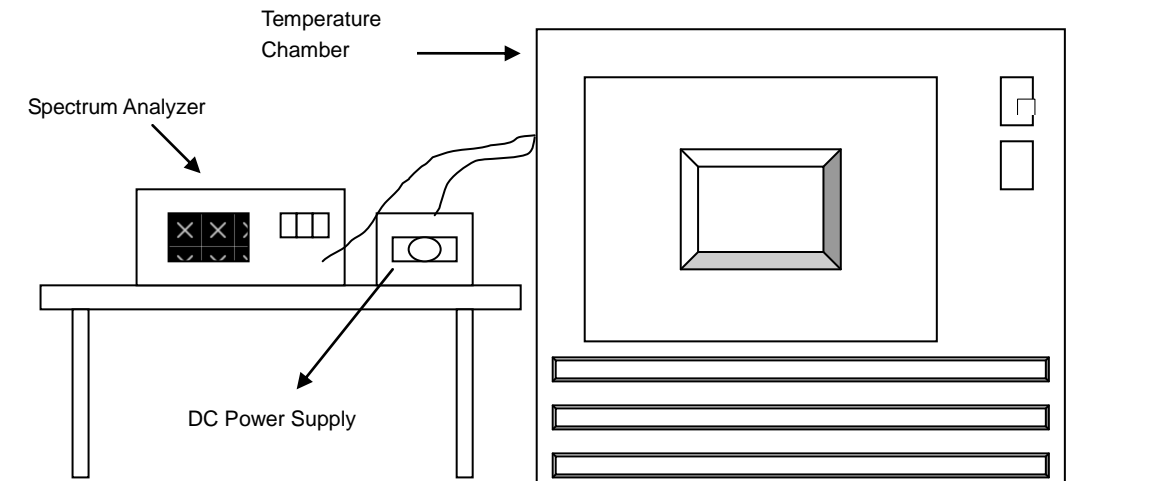

4.5.3 TEST INSTRUMENTS

Refer to section 4.1.3 to get information of above instrument.

4.5.4 TEST PROCEDURE

- a. To ensure emission at the band edge is maintained within the authorized band, those values shall be measured by radiation emissions at upper and lower frequency points, and finally compensated by frequency deviation as procedures below.
- b. The EUT was operated at the maximum output power, and connected to the spectrum analyzer, which is set to maximum hold function and peak detector. The peak value of the power envelope was measured and noted. The upper and lower frequency points were respectively measured relatively 10dB lower than the measured peak value.
- c. The frequency deviation was calculated by adding the upper frequency point and the lower frequency point divided by two. Those detailed values of frequency deviation are provided in table below.

4.5.5 DEVIATION FROM TEST STANDARD

No deviation.

4.5.6 EUT OPERATING CONDITION

Set the EUT transmit at un-modulation mode to test frequency stability.



A D T

4.5.7 TEST RESULTS

Mode A

FREQUENCY STABILITY VERSUS TEMP.									
OPERATING FREQUENCY: 5180MHz									
TEMP. (°C)	POWER SUPPLY (Vdc)	0 MINUTE		2 MINUTE		5 MINUTE		10 MINUTE	
		Measured Frequency (MHz)	Frequency Drift (ppm)	Measured Frequency (MHz)	Frequency Drift (ppm)	Measured Frequency (MHz)	Frequency Drift (ppm)	Measured Frequency (MHz)	Frequency Drift (ppm)
50	3.7	5180.037638	7.266	5180.037177	7.177	5180.037312	7.203	5180.037095	7.161
40	3.7	5180.036904	7.124	5180.037034	7.149	5180.036949	7.133	5180.036904	7.124
30	3.7	5180.038689	7.469	5180.038733	7.477	5180.038342	7.402	5180.038358	7.405
20	3.7	5180.039394	7.605	5180.039500	7.625	5180.039134	7.555	5180.039634	7.651
10	3.7	5180.040750	7.867	5180.040474	7.814	5180.041118	7.938	5180.040796	7.876
0	3.7	5180.039515	7.628	5180.039127	7.553	5180.039514	7.628	5180.039271	7.581
-10	3.7	5180.037590	7.257	5180.037518	7.243	5180.038048	7.345	5180.037868	7.310
-20	3.7	5180.036537	7.053	5180.036786	7.102	5180.036747	7.094	5180.037025	7.148
-30	3.7	5180.036354	7.018	5180.036199	6.988	5180.035826	6.916	5180.036063	6.962

FREQUENCY STABILITY VERSUS VOLTAGE									
OPERATING FREQUENCY: 5180MHz									
TEMP. (°C)	POWER SUPPLY (Vdc)	0 MINUTE		2 MINUTE		5 MINUTE		10 MINUTE	
		Measured Frequency (MHz)	Frequency Drift (ppm)	Measured Frequency (MHz)	Frequency Drift (ppm)	Measured Frequency (MHz)	Frequency Drift (ppm)	Measured Frequency (MHz)	Frequency Drift (ppm)
20	3.4	5180.039103	7.549	5180.038461	7.425	5180.038705	7.472	5180.038919	7.513
	3.7	5180.039394	7.605	5180.039500	7.625	5180.039134	7.555	5180.039634	7.651
	4.20	5180.040820	7.880	5180.040523	7.823	5180.040432	7.805	5180.040646	7.847



A D T

FREQUENCY STABILITY VERSUS TEMP.									
OPERATING FREQUENCY: 5320MHz									
TEMP. (°C)	POWER SUPPLY (Vdc)	0 MINUTE		2 MINUTE		5 MINUTE		10 MINUTE	
		Measured Frequency (MHz)	Frequency Drift (ppm)	Measured Frequency (MHz)	Frequency Drift (ppm)	Measured Frequency (MHz)	Frequency Drift (ppm)	Measured Frequency (MHz)	Frequency Drift (ppm)
50	3.7	5320.037164	6.986	5320.036584	6.877	5320.036621	6.884	5320.036914	6.939
40	3.7	5320.036516	6.864	5320.037172	6.987	5320.036924	6.941	5320.036681	6.895
30	3.7	5320.038445	7.227	5320.038404	7.219	5320.038018	7.146	5320.038436	7.225
20	3.7	5320.039078	7.345	5320.038960	7.323	5320.039133	7.356	5320.038989	7.329
10	3.7	5320.040678	7.646	5320.040531	7.619	5320.040372	7.589	5320.040737	7.657
0	3.7	5320.039226	7.373	5320.038757	7.285	5320.038972	7.326	5320.039464	7.418
-10	3.7	5320.037622	7.072	5320.037911	7.126	5320.037683	7.083	5320.037576	7.063
-20	3.7	5320.036739	6.906	5320.036836	6.924	5320.036706	6.900	5320.037337	7.018
-30	3.7	5320.036071	6.780	5320.035965	6.760	5320.036279	6.819	5320.036169	6.799

FREQUENCY STABILITY VERSUS VOLTAGE									
OPERATING FREQUENCY: 5320MHz									
TEMP. (°C)	POWER SUPPLY (Vdc)	0 MINUTE		2 MINUTE		5 MINUTE		10 MINUTE	
		Measured Frequency (MHz)	Frequency Drift (ppm)	Measured Frequency (MHz)	Frequency Drift (ppm)	Measured Frequency (MHz)	Frequency Drift (ppm)	Measured Frequency (MHz)	Frequency Drift (ppm)
20	3.4	5320.038655	7.266	5320.038727	7.280	5320.038265	7.193	5320.038499	7.237
	3.7	5320.039078	7.345	5320.038960	7.323	5320.039133	7.356	5320.038989	7.329
	4.20	5320.040524	7.617	5320.040631	7.637	5320.040734	7.657	5320.040287	7.573



A D T

Mode B

FREQUENCY STABILITY VERSUS TEMP.									
OPERATING FREQUENCY: 5180MHz									
TEMP. (°C)	POWER SUPPLY (Vdc)	0 MINUTE		2 MINUTE		5 MINUTE		10 MINUTE	
		Measured Frequency (MHz)	Frequency Drift (ppm)	Measured Frequency (MHz)	Frequency Drift (ppm)	Measured Frequency (MHz)	Frequency Drift (ppm)	Measured Frequency (MHz)	Frequency Drift (ppm)
50	3.7	5180.037638	7.266	5180.037177	7.177	5180.037312	7.203	5180.037095	7.161
40	3.7	5180.036904	7.124	5180.037034	7.149	5180.036949	7.133	5180.036904	7.124
30	3.7	5180.038689	7.469	5180.038733	7.477	5180.038342	7.402	5180.038358	7.405
20	3.7	5180.039394	7.605	5180.039500	7.625	5180.039134	7.555	5180.039634	7.651
10	3.7	5180.040750	7.867	5180.040474	7.814	5180.041118	7.938	5180.040796	7.876
0	3.7	5180.039515	7.628	5180.039127	7.553	5180.039514	7.628	5180.039271	7.581
-10	3.7	5180.037590	7.257	5180.037518	7.243	5180.038048	7.345	5180.037868	7.310
-20	3.7	5180.036537	7.053	5180.036786	7.102	5180.036747	7.094	5180.037025	7.148
-30	3.7	5180.036354	7.018	5180.036199	6.988	5180.035826	6.916	5180.036063	6.962

FREQUENCY STABILITY VERSUS VOLTAGE									
OPERATING FREQUENCY: 5180MHz									
TEMP. (°C)	POWER SUPPLY (Vdc)	0 MINUTE		2 MINUTE		5 MINUTE		10 MINUTE	
		Measured Frequency (MHz)	Frequency Drift (ppm)	Measured Frequency (MHz)	Frequency Drift (ppm)	Measured Frequency (MHz)	Frequency Drift (ppm)	Measured Frequency (MHz)	Frequency Drift (ppm)
20	3.4	5180.039103	7.549	5180.038461	7.425	5180.038705	7.472	5180.038919	7.513
	3.7	5180.039394	7.605	5180.039500	7.625	5180.039134	7.555	5180.039634	7.651
	4.20	5180.040820	7.880	5180.040523	7.823	5180.040432	7.805	5180.040646	7.847



A D T

FREQUENCY STABILITY VERSUS TEMP.									
OPERATING FREQUENCY: 5320MHz									
TEMP. (°C)	POWER SUPPLY (Vdc)	0 MINUTE		2 MINUTE		5 MINUTE		10 MINUTE	
		Measured Frequency (MHz)	Frequency Drift (ppm)	Measured Frequency (MHz)	Frequency Drift (ppm)	Measured Frequency (MHz)	Frequency Drift (ppm)	Measured Frequency (MHz)	Frequency Drift (ppm)
50	3.7	5320.037164	6.986	5320.036584	6.877	5320.036621	6.884	5320.036914	6.939
40	3.7	5320.036516	6.864	5320.037172	6.987	5320.036924	6.941	5320.036681	6.895
30	3.7	5320.038445	7.227	5320.038404	7.219	5320.038018	7.146	5320.038436	7.225
20	3.7	5320.039078	7.345	5320.038960	7.323	5320.039133	7.356	5320.038989	7.329
10	3.7	5320.040678	7.646	5320.040531	7.619	5320.040372	7.589	5320.040737	7.657
0	3.7	5320.039226	7.373	5320.038757	7.285	5320.038972	7.326	5320.039464	7.418
-10	3.7	5320.037622	7.072	5320.037911	7.126	5320.037683	7.083	5320.037576	7.063
-20	3.7	5320.036739	6.906	5320.036836	6.924	5320.036706	6.900	5320.037337	7.018
-30	3.7	5320.036071	6.780	5320.035965	6.760	5320.036279	6.819	5320.036169	6.799

FREQUENCY STABILITY VERSUS VOLTAGE									
OPERATING FREQUENCY: 5320MHz									
TEMP. (°C)	POWER SUPPLY (Vdc)	0 MINUTE		2 MINUTE		5 MINUTE		10 MINUTE	
		Measured Frequency (MHz)	Frequency Drift (ppm)	Measured Frequency (MHz)	Frequency Drift (ppm)	Measured Frequency (MHz)	Frequency Drift (ppm)	Measured Frequency (MHz)	Frequency Drift (ppm)
20	3.4	5320.038655	7.266	5320.038727	7.280	5320.038265	7.193	5320.038499	7.237
	3.7	5320.039078	7.345	5320.038960	7.323	5320.039133	7.356	5320.038989	7.329
	4.20	5320.040524	7.617	5320.040631	7.637	5320.040734	7.657	5320.040287	7.573

4.6 6dB BANDWIDTH MEASUREMENT

4.6.1 LIMITS OF 6dB BANDWIDTH MEASUREMENT

The minimum of 6dB Bandwidth Measurement is 0.5MHz.

4.6.2 TEST SETUP

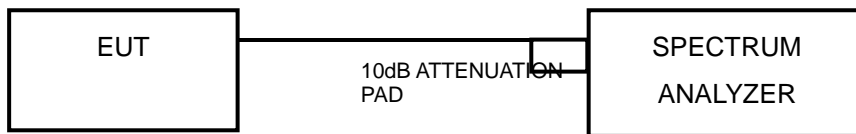

4.6.3 TEST INSTRUMENTS

Refer to section 4.1.3 to get information of above instrument.

4.6.4 TEST PROCEDURE

- Set resolution bandwidth (RBW) = 100kHz
- Set the video bandwidth (VBW) $\geq 3 \times$ RBW, Detector = Peak.
- Trace mode = max hold.
- Sweep = auto couple.
- Measure the maximum width of the emission that is constrained by the frequencies associated with the two amplitude points (upper and lower) that are attenuated by 6 dB relative to the maximum level measured in the fundamental emission.

4.6.5 DEVIATION FROM TEST STANDARD

No deviation.

4.6.6 EUT OPERATING CONDITIONS

The software provided by client to enable the EUT under transmission condition continuously at lowest, middle and highest channel frequencies individually.



A D T

4.6.7 TEST RESULTS

Mode A

802.11a

CHANNEL	FREQUENCY (MHz)	6dB BANDWIDTH (MHz)	MINIMUM LIMIT (MHz)	PASS / FAIL
149	5745	15.11	0.5	PASS
157	5785	13.11	0.5	PASS
165	5825	15.70	0.5	PASS

802.11n (20MHz)

CHANNEL	FREQUENCY (MHz)	6dB BANDWIDTH (MHz)	MINIMUM LIMIT (MHz)	PASS / FAIL
149	5745	14.25	0.5	PASS
157	5785	15.07	0.5	PASS
165	5825	15.09	0.5	PASS

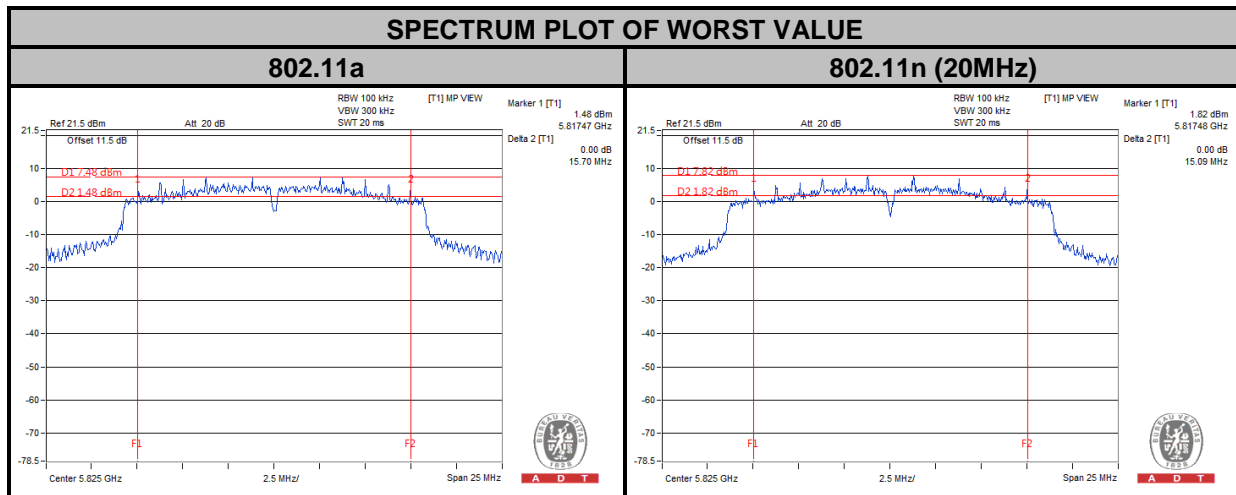



A D T

Mode B

802.11a

CHANNEL	FREQUENCY (MHz)	6dB BANDWIDTH (MHz)	MINIMUM LIMIT (MHz)	PASS / FAIL
149	5745	15.11	0.5	PASS
157	5785	13.11	0.5	PASS
165	5825	15.70	0.5	PASS

802.11n (20MHz)

CHANNEL	FREQUENCY (MHz)	6dB BANDWIDTH (MHz)	MINIMUM LIMIT (MHz)	PASS / FAIL
149	5745	14.25	0.5	PASS
157	5785	15.07	0.5	PASS
165	5825	15.09	0.5	PASS

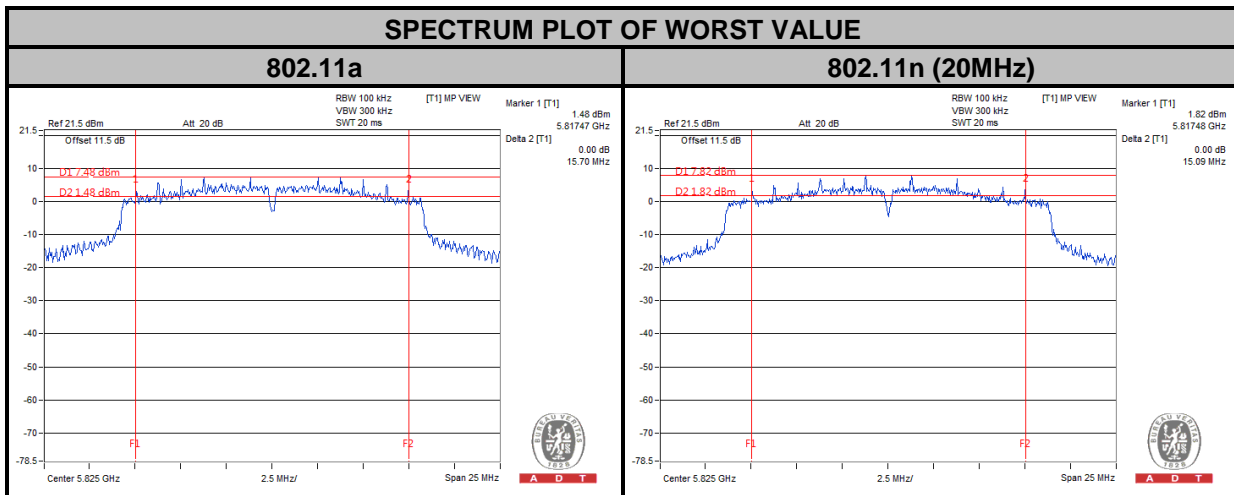



A D T

5. PHOTOGRAPHS OF THE TEST CONFIGURATION

Please refer to the attached file (Test Setup Photo).



6. INFORMATION ON THE TESTING LABORATORIES

We, Bureau Veritas Consumer Products Services (H.K.) Ltd., Taoyuan Branch, were founded in 1988 to provide our best service in EMC, Radio, Telecom and Safety consultation. Our laboratories are accredited and approved according to ISO/IEC 17025.

If you have any comments, please feel free to contact us at the following:

Linko EMC/RF Lab:

Tel: 886-2-26052180

Fax: 886-2-26051924

Hsin Chu EMC/RF/Telecom Lab:

Tel: 886-3-5935343

Fax: 886-3-5935342

Hwa Ya EMC/RF/Safety Lab:

Tel: 886-3-3183232

Fax: 886-3-3270892

Email: service.adt@tw.bureauveritas.com

Web Site: www.bureauveritas-adt.com

The address and road map of all our labs can be found in our web site also.



A D T

7. APPENDIX A - MODIFICATIONS RECORDERS FOR ENGINEERING CHANGES TO THE EUT BY THE LAB

No any modifications are made to the EUT by the lab during the test.

---END---