



FCC SAR Test Report

Report No. : SA120903C21
Applicant : Motorola Solutions, Inc.
Address : One Motorola Plaza, Holtsville, NY 11742-1300 USA
Product : Mobile Computer
FCC ID : UZ7MC40N0
Brand : Motorola
Model No. : MC40N0
Standards : FCC 47 CFR Part 2 (2.1093) / IEEE C95.1:1991 / IEEE 1528:2003
 FCC OET Bulletin 65 Supplement C (Edition 01-01)
 KDB 248227 D01 v01r02 / KDB 447498 D01 v04
Date of Testing : Aug. 11, 2012 ~ Aug. 24, 2012

CERTIFICATION: The above equipment have been tested by **Bureau Veritas Consumer Products Services (H.K.) Ltd., Taoyuan Branch - Taiwan HwaYa Lab**, and found compliance with the requirement of the above standards. The test record, data evaluation & Equipment Under Test (EUT) configurations represented herein are true and accurate accounts of the measurements of the sample’s SAR characteristics under the conditions specified in this report. It should not be reproduced except in full, without the written approval of our laboratory. The client should not use it to claim product certification, approval, or endorsement by TAF or any government agencies.

Prepared By : Ivonne Wu
 Ivonne Wu / Senior Specialist
Approved By : Roy Wu
 Roy Wu / Manager



This report is for your exclusive use. Any copying or replication of this report to or for any other person or entity, or use of our name or trademark, is permitted only with our prior written permission. This report sets forth our findings solely with respect to the test samples identified herein. The results set forth in this report are not indicative or representative of the quality or characteristics of the lot from which a test sample was taken or any similar or identical product unless specifically and expressly noted. Our report includes all of the tests requested by you and the results thereof based upon the information that you provided to us. You have 60 days from date of issuance of this report to notify us of any material error or omission caused by our negligence, provided, however, that such notice shall be in writing and shall specifically address the issue you wish to raise. A failure to raise such issue within the prescribed time shall constitute your unqualified acceptance of the completeness of this report, the tests conducted and the correctness of the report contents. Unless specific mention, the uncertainty of measurement has been explicitly taken into account to declare the compliance or non-compliance to the specification.



Table of Contents

Release Control Record	3
1. Summary of Maximum SAR Value	4
2. Description of Equipment Under Test	5
3. SAR Measurement System	6
3.1 Definition of Specific Absorption Rate (SAR).....	6
3.2 SPEAG DASY System	6
3.2.1 Robot.....	7
3.2.2 Probes.....	8
3.2.3 Data Acquisition Electronics (DAE)	8
3.2.4 Phantoms	9
3.2.5 Device Holder.....	10
3.2.6 System Validation Dipoles	10
3.2.7 Tissue Simulating Liquids.....	11
3.3 SAR System Verification	12
3.4 SAR Measurement Procedure	13
3.4.1 Area & Zoom Scan Procedure	13
3.4.2 Volume Scan Procedure.....	13
3.4.3 Power Drift Monitoring.....	13
3.4.4 Spatial Peak SAR Evaluation	14
3.4.5 SAR Averaged Methods	14
4. SAR Measurement Evaluation	15
4.1 EUT Configuration and Setting.....	15
4.2 EUT Testing Position	15
4.3 Tissue Verification	17
4.4 System Verification.....	18
4.5 Conducted Power Results.....	19
4.6 SAR Testing Results.....	21
4.6.1 SAR Results for Head	21
4.6.2 SAR Results for Body.....	23
5. Calibration of Test Equipment	24
6. Measurement Uncertainty	25
7. Information on the Testing Laboratories	27
Appendix A. SAR Plots of System Verification	
Appendix B. SAR Plots of SAR Measurement	
Appendix C. Calibration Certificate for Probe and Dipole	
Appendix D. Photographs of EUT and Setup	



Release Control Record

Issue No.	Reason for Change	Date Issued
R01	Original release	Sep. 17, 2012



1. Summary of Maximum SAR Value

Mode / Band	Test Position	SAR-1g (W/kg)
WLAN 2.4GHz	Head	0.257
	Body (w/o Holster, 1.5 cm Gap)	0.161
	Body (with Holster, 0 cm Gap)	0.28
WLAN 5GHz	Head	0.147
	Body (w/o Holster, 1.5 cm Gap)	0.663
	Body (with Holster, 0 cm Gap)	0.505
Bluetooth	Head	N/A
	Body (w/o Holster, 1.5 cm Gap)	N/A
	Body (with Holster, 0 cm Gap)	N/A

Note:

1. The SAR limit (**1.6 W/kg**) for general population/uncontrolled exposure is specified in FCC 47 CFR part 2 (2.1093) and ANSI/IEEE C95.1-1991.
2. Since the Bluetooth maximum power is less than 60/f, SAR testing for Bluetooth is not required.



FCC SAR Test Report

2. Description of Equipment Under Test

EUT Type	Mobile Computer
FCC ID	UZ7MC40N0
Brand Name	Motorola
Model Name	MC40N0
SW Version	Android 2.3.4 Build number 9927301-G-0500-0003-00-E2-072312
HW Version	EV2 (PCBA: 12H00-SD)
Tx Frequency Bands (Unit: MHz)	WLAN : 2400 ~ 2483.5, 5150 ~ 5350, 5470 ~ 5725, 5725 ~ 5825 Bluetooth : 2400 ~ 2483.5
Uplink Modulations	802.11b : DSSS 802.11a/g/n : OFDM
Maximum AVG Conducted Power (Unit: dBm)	802.11b : 22.59 802.11g : 22.60 802.11n HT20 (2.4GHz) : 21.89 802.11a : 19.31 802.11n HT20 (5GHz) : 18.92 Bluetooth : 3.26
Antenna Type	PIFA Antenna
EUT Stage	Identical Prototype

Note:

1. The above EUT information is declared by manufacturer and for more detailed features description please refers to the manufacturer's specifications or User's Manual.

List of Accessory:

Battery	Brand Name	Motorola
	Power Rating	3.7Vdc, 2680mAh
	Type	Li-ion

3. SAR Measurement System

3.1 Definition of Specific Absorption Rate (SAR)

SAR is related to the rate at which energy is absorbed per unit mass in an object exposed to a radio field. The SAR distribution in a biological body is complicated and is usually carried out by experimental techniques or numerical modeling. The standard recommends limits for two tiers of groups, occupational/controlled and general population/uncontrolled, based on a person's awareness and ability to exercise control over his or her exposure. In general, occupational/controlled exposure limits are higher than the limits for general population/uncontrolled.

The SAR definition is the time derivative (rate) of the incremental energy (dW) absorbed by (dissipated in) an incremental mass (dm) contained in a volume element (dv) of a given density (ρ). The equation description is as below:

$$\text{SAR} = \frac{d}{dt} \left(\frac{dW}{dm} \right) = \frac{d}{dt} \left(\frac{dW}{\rho dv} \right)$$

SAR is expressed in units of Watts per kilogram (W/kg)

SAR measurement can be related to the electrical field in the tissue by

$$\text{SAR} = \frac{\sigma |E|^2}{\rho}$$

Where: σ is the conductivity of the tissue, ρ is the mass density of the tissue and E is the RMS electrical field strength.

3.2 SPEAG DASY System

DASY system consists of high precision robot, probe alignment sensor, phantom, robot controller, controlled measurement server and near-field probe. The robot includes six axes that can move to the precision position of the DASY4/5 software defined. The DASY software can define the area that is detected by the probe. The robot is connected to controlled box. Controlled measurement server is connected to the controlled robot box. The DAE includes amplifier, signal multiplexing, AD converter, offset measurement and surface detection. It is connected to the Electro-optical coupler (ECO). The ECO performs the conversion from the optical into digital electric signal of the DAE and transfers data to the PC.

FCC SAR Test Report

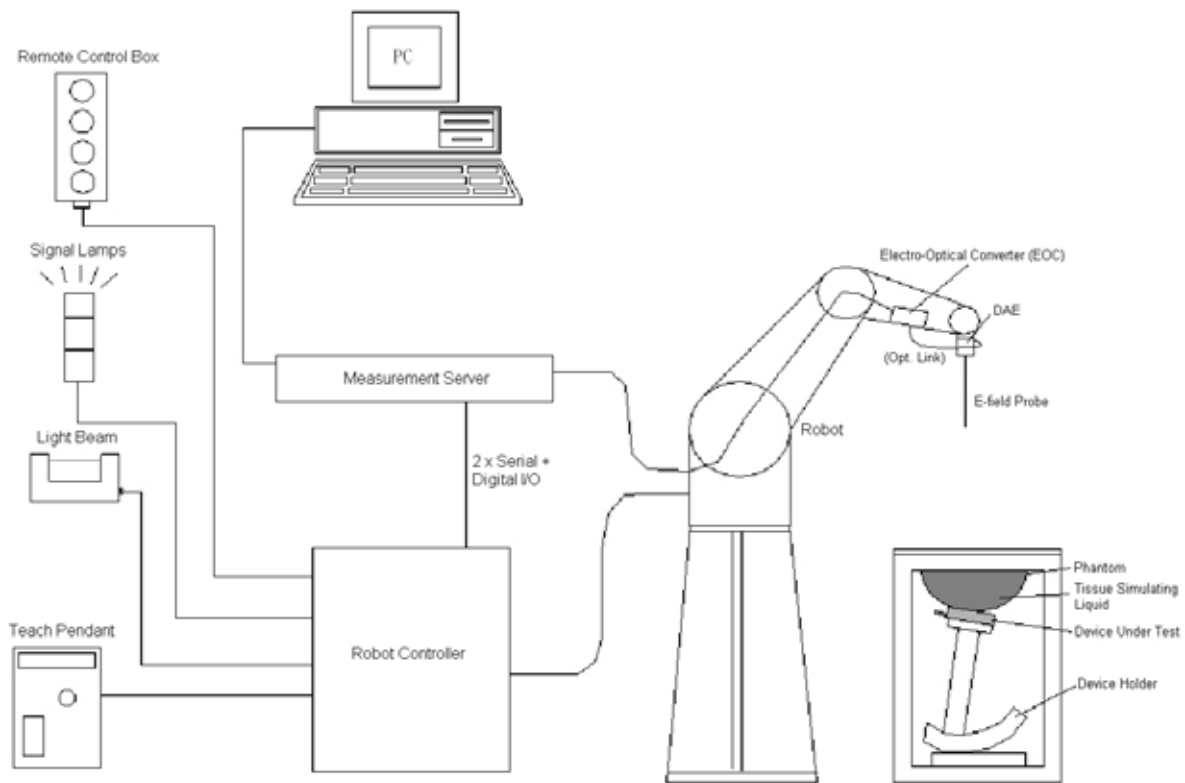

Fig-3.1 DASY System Setup

3.2.1 Robot

The DASY system uses the high precision robots from Stäubli SA (France). For the 6-axis controller system, the robot controller version (DASY4: CS7MB; DASY5: CS8c) from Stäubli is used. The Stäubli robot series have many features that are important for our application:

- High precision (repeatability ± 0.035 mm)
- High reliability (industrial design)
- Jerk-free straight movements
- Low ELF interference (the closed metallic construction shields against motor control fields)



Fig-3.2 DASY4



Fig-3.3 DASY5

FCC SAR Test Report

3.2.2 Probes

The SAR measurement is conducted with the dosimetric probe. The probe is specially designed and calibrated for use in liquid with high permittivity. The dosimetric probe has special calibration in liquid at different frequency.

Model	EX3DV4	
Construction	Symmetrical design with triangular core. Built-in shielding against static charges. PEEK enclosure material (resistant to organic solvents, e.g., DGBE).	
Frequency	10 MHz to 6 GHz Linearity: ± 0.2 dB	
Directivity	± 0.3 dB in HSL (rotation around probe axis) ± 0.5 dB in tissue material (rotation normal to probe axis)	
Dynamic Range	10 μ W/g to 100 mW/g Linearity: ± 0.2 dB (noise: typically < 1 μ W/g)	
Dimensions	Overall length: 337 mm (Tip: 20 mm) Tip diameter: 2.5 mm (Body: 12 mm) Typical distance from probe tip to dipole centers: 1 mm	

Model	ES3DV3	
Construction	Symmetrical design with triangular core. Interleaved sensors. Built-in shielding against static charges. PEEK enclosure material (resistant to organic solvents, e.g., DGBE).	
Frequency	10 MHz to 4 GHz Linearity: ± 0.2 dB	
Directivity	± 0.2 dB in HSL (rotation around probe axis) ± 0.3 dB in tissue material (rotation normal to probe axis)	
Dynamic Range	5 μ W/g to 100 mW/g Linearity: ± 0.2 dB	
Dimensions	Overall length: 337 mm (Tip: 20 mm) Tip diameter: 3.9 mm (Body: 12 mm) Distance from probe tip to dipole centers: 2.0 mm	

3.2.3 Data Acquisition Electronics (DAE)

Model	DAE3, DAE4	
Construction	Signal amplifier, multiplexer, A/D converter and control logic. Serial optical link for communication with DASY4/5 embedded system (fully remote controlled). Two step probe touch detector for mechanical surface detection and emergency robot stop.	
Measurement Range	-100 to +300 mV (16 bit resolution and two range settings: 4mV, 400mV)	
Input Offset Voltage	< 5 μ V (with auto zero)	
Input Bias Current	< 50 fA	
Dimensions	60 x 60 x 68 mm	

3.2.4 Phantoms

Model	Twin SAM	
Construction	The shell corresponds to the specifications of the Specific Anthropomorphic Mannequin (SAM) phantom defined in IEEE 1528 and IEC 62209-1. It enables the dosimetric evaluation of left and right hand phone usage as well as body mounted usage at the flat phantom region. A cover prevents evaporation of the liquid. Reference markings on the phantom allow the complete setup of all predefined phantom positions and measurement grids by teaching three points with the robot.	
Material	Vinylester, glass fiber reinforced (VE-GF)	
Shell Thickness	2 ± 0.2 mm (6 ± 0.2 mm at ear point)	
Dimensions	Length: 1000 mm Width: 500 mm Height: adjustable feet	
Filling Volume	approx. 25 liters	

Model	ELI	
Construction	Phantom for compliance testing of handheld and body-mounted wireless devices in the frequency range of 30 MHz to 6 GHz. ELI is fully compatible with the IEC 62209-2 standard and all known tissue simulating liquids. ELI has been optimized regarding its performance and can be integrated into our standard phantom tables. A cover prevents evaporation of the liquid. Reference markings on the phantom allow installation of the complete setup, including all predefined phantom positions and measurement grids, by teaching three points. The phantom is compatible with all SPEAG dosimetric probes and dipoles.	
Material	Vinylester, glass fiber reinforced (VE-GF)	
Shell Thickness	2.0 ± 0.2 mm (bottom plate)	
Dimensions	Major axis: 600 mm Minor axis: 400 mm	
Filling Volume	approx. 30 liters	

FCC SAR Test Report

3.2.5 Device Holder

Model	Mounting Device	
Construction	In combination with the Twin SAM Phantom or ELI4, the Mounting Device enables the rotation of the mounted transmitter device in spherical coordinates. Rotation point is the ear opening point. Transmitter devices can be easily and accurately positioned according to IEC, IEEE, FCC or other specifications. The device holder can be locked for positioning at different phantom sections (left head, right head, flat).	
Material	POM	

Model	Laptop Extensions Kit	
Construction	Simple but effective and easy-to-use extension for Mounting Device that facilitates the testing of larger devices according to IEC 62209-2 (e.g., laptops, cameras, etc.). It is lightweight and fits easily on the upper part of the Mounting Device in place of the phone positioner.	
Material	POM, Acrylic glass, Foam	

3.2.6 System Validation Dipoles

Model	D-Serial	
Construction	Symmetrical dipole with 1/4 balun. Enables measurement of feed point impedance with NWA. Matched for use near flat phantoms filled with tissue simulating solutions.	
Frequency	750 MHz to 5800 MHz	
Return Loss	> 20 dB	
Power Capability	> 100 W (f < 1GHz), > 40 W (f > 1GHz)	

FCC SAR Test Report

3.2.7 Tissue Simulating Liquids

For SAR measurement of the field distribution inside the phantom, the phantom must be filled with homogeneous tissue simulating liquid to a depth of at least 15 cm. For head SAR testing, the liquid height from the ear reference point (ERP) of the phantom to the liquid top surface is larger than 15 cm. For body SAR testing, the liquid height from the center of the flat phantom to the liquid top surface is larger than 15 cm. The nominal dielectric values of the tissue simulating liquids in the phantom and the tolerance of 5% are listed in Table-3.1.

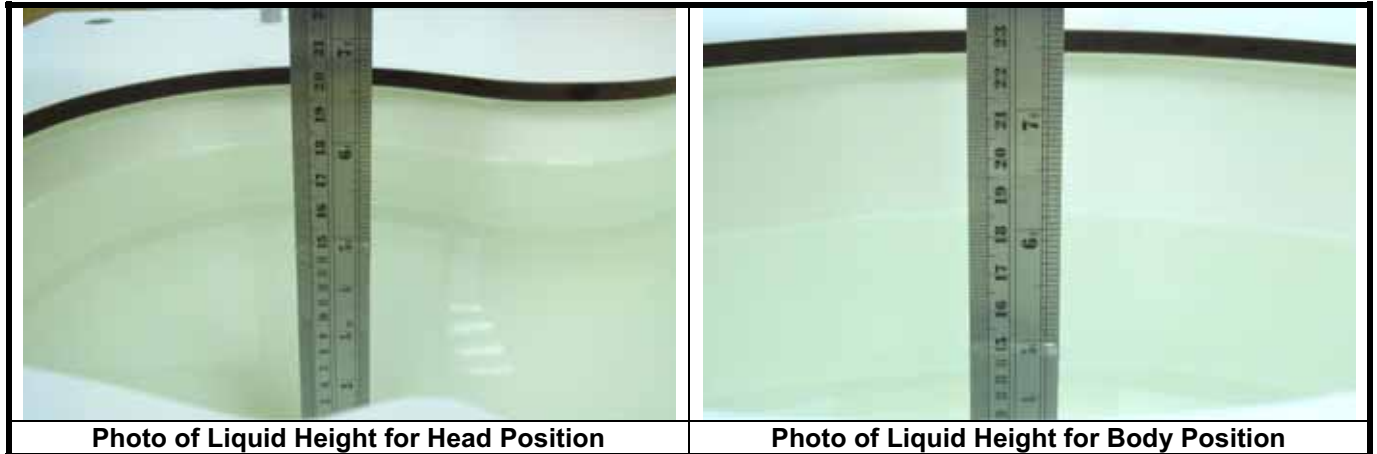

The dielectric properties of the head tissue simulating liquids are defined in IEEE 1528 and FCC OET 65 Supplement C Appendix C. For the body tissue simulating liquids, the dielectric properties are defined in FCC OET 65 Supplement C Appendix C. The dielectric properties of the tissue simulating liquids were verified prior to the SAR evaluation using an Agilent 85070D Dielectric Probe Kit and an Agilent Network Analyzer.

Table-3.1 Targets of Tissue Simulating Liquid

Frequency (MHz)	Target Permittivity	Range of $\pm 5\%$	Target Conductivity	Range of $\pm 5\%$
For Head				
2450	39.2	37.2 ~ 41.2	1.80	1.71 ~ 1.89
5200	36.0	34.2 ~ 37.8	4.66	4.43 ~ 4.89
5300	35.9	34.1 ~ 37.7	4.76	4.52 ~ 5.00
5500	35.6	33.8 ~ 37.4	4.96	4.71 ~ 5.21
5600	35.5	33.7 ~ 37.3	5.07	4.82 ~ 5.32
5800	35.3	33.5 ~ 37.1	5.27	5.01 ~ 5.53
For Body				
2450	52.7	50.1 ~ 55.3	1.95	1.85 ~ 2.05
5300	48.9	46.5 ~ 51.3	5.42	5.15 ~ 5.69
5500	48.6	46.2 ~ 51.0	5.65	5.37 ~ 5.93
5600	48.5	46.1 ~ 50.9	5.77	5.48 ~ 6.06
5800	48.2	45.8 ~ 50.6	6.00	5.70 ~ 6.30

FCC SAR Test Report

The following table gives the recipes for tissue simulating liquids.

Table-3.2 Recipes of Tissue Simulating Liquid

Tissue Type	Bactericide	DGBE	HEC	NaCl	Sucrose	Triton X-100	Water	Diethylene Glycol Mono-hexylether
H2450	-	45.0	-	0.1	-	-	54.9	-
H5G	-	-	-	-	-	17.2	65.5	17.3
B2450	-	31.4	-	0.1	-	-	68.5	-
B5G	-	-	-	-	-	10.7	78.6	10.7

3.3 SAR System Verification

The system check verifies that the system operates within its specifications. It is performed daily or before every SAR measurement. The system check uses normal SAR measurements in the flat section of the phantom with a matched dipole at a specified distance. The system verification setup is shown as below.

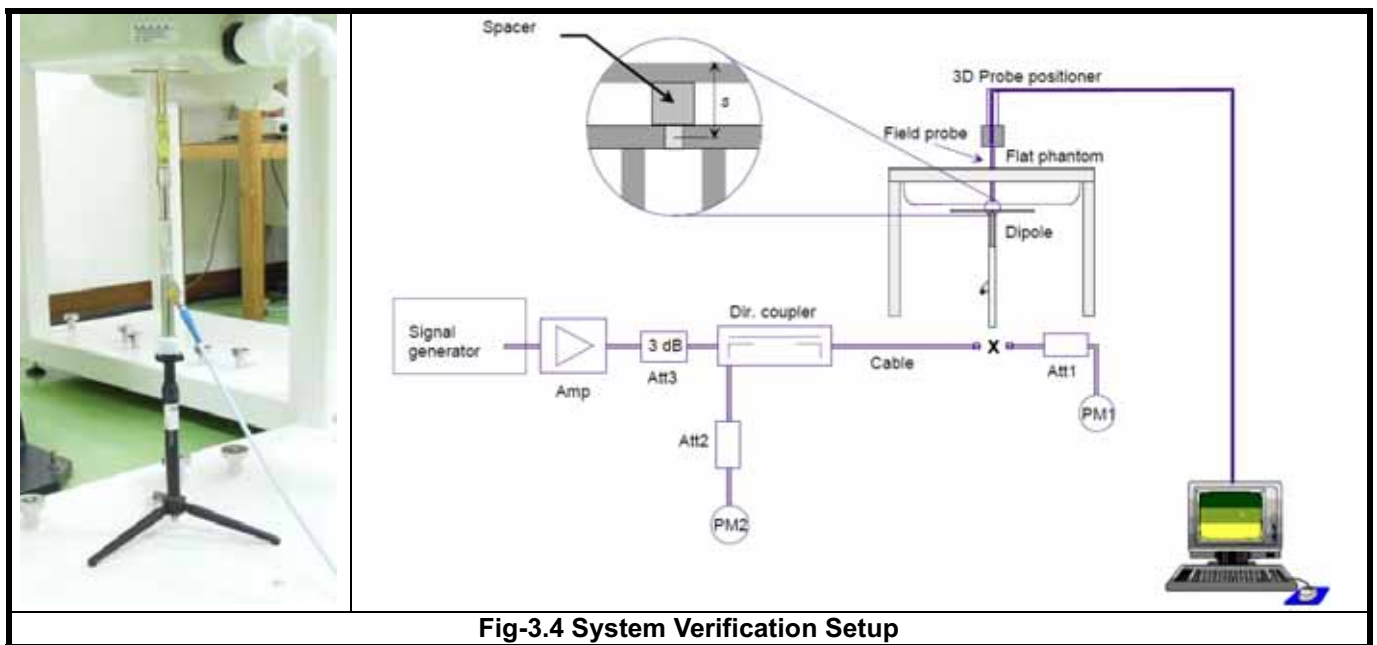

Fig-3.4 System Verification Setup

The validation dipole is placed beneath the flat phantom with the specific spacer in place. The distance spacer is touch the phantom surface with a light pressure at the reference marking and be oriented parallel to the long side of the phantom. The power meter PM1 measures the forward power at the location of the system check dipole connector. The signal generator is adjusted for the desired forward power (250 mW is used for 700 MHz to 3 GHz, 100 mW is used for 3.5 GHz to 6 GHz) at the dipole connector and the power meter PM2 is read at that level. After connecting the cable to the dipole, the signal generator is readjusted for the same reading at power meter PM2.

After system check testing, the SAR result will be normalized to 1W forward input power and compared with the reference SAR value derived from validation dipole certificate report. The deviation of system check should be within 10 %.



3.4 SAR Measurement Procedure

According to the SAR test standard, the recommended procedure for assessing the peak spatial-average SAR value consists of the following steps:

- (a) Power reference measurement
- (b) Area scan
- (c) Zoom scan
- (d) Power drift measurement

The SAR measurement procedures for each of test conditions are as follows:

- (a) Make EUT to transmit maximum output power
- (b) Measure conducted output power through RF cable
- (c) Place the EUT in the specific position of phantom
- (d) Perform SAR testing steps on the DASY system
- (e) Record the SAR value

3.4.1 Area & Zoom Scan Procedure

First Area Scan is used to locate the approximate location(s) of the local peak SAR value(s). The measurement grid within an Area Scan is defined by the grid extent, grid step size and grid offset. Next, in order to determine the EM field distribution in a three-dimensional spatial extension, Zoom Scan is required. The Zoom Scan measures 5x5x7 points with step size 8, 8 and 5 mm for below 3 GHz, and 7x7x9 points with step size 4, 4 and 2.5 mm for above 5 GHz. The Zoom Scan is performed around the highest E-field value to determine the averaged SAR-distribution over 10 g.

3.4.2 Volume Scan Procedure

The volume scan is used for assess overlapping SAR distributions for antennas transmitting in different frequency bands. It is equivalent to an oversized zoom scan used in standalone measurements. The measurement volume will be used to enclose all the simultaneous transmitting antennas. For antennas transmitting simultaneously in different frequency bands, the volume scan is measured separately in each frequency band. In order to sum correctly to compute the 1g aggregate SAR, the EUT remain in the same test position for all measurements and all volume scan use the same spatial resolution and grid spacing. When all volume scan were completed, the software, SEMCAD postprocessor can combine and subsequently superpose these measurement data to calculating the multiband SAR.

3.4.3 Power Drift Monitoring

All SAR testing is under the EUT install full charged battery and transmit maximum output power. In DASY measurement software, the power reference measurement and power drift measurement procedures are used for monitoring the power drift of EUT during SAR test. Both these procedures measure the field at a specified reference position before and after the SAR testing. The software will calculate the field difference in dB. If the power drift more than 5%, the SAR will be retested.



FCC SAR Test Report

3.4.4 Spatial Peak SAR Evaluation

The procedure for spatial peak SAR evaluation has been implemented according to the test standard. It can be conducted for 1g and 10g, as well as for user-specific masses. The DASY software includes all numerical procedures necessary to evaluate the spatial peak SAR value.

The base for the evaluation is a "cube" measurement. The measured volume must include the 1g and 10g cubes with the highest averaged SAR values. For that purpose, the center of the measured volume is aligned to the interpolated peak SAR value of a previously performed area scan.

The entire evaluation of the spatial peak values is performed within the post-processing engine (SEMCAD). The system always gives the maximum values for the 1g and 10g cubes. The algorithm to find the cube with highest averaged SAR is divided into the following stages:

- (a) Extraction of the measured data (grid and values) from the Zoom Scan
- (b) Calculation of the SAR value at every measurement point based on all stored data (A/D values and measurement parameters)
- (c) Generation of a high-resolution mesh within the measured volume
- (d) Interpolation of all measured values from the measurement grid to the high-resolution grid
- (e) Extrapolation of the entire 3-D field distribution to the phantom surface over the distance from sensor to surface
- (f) Calculation of the averaged SAR within masses of 1g and 10g

3.4.5 SAR Averaged Methods

In DASY, the interpolation and extrapolation are both based on the modified Quadratic Shepard's method. The interpolation scheme combines a least-square fitted function method and a weighted average method which are the two basic types of computational interpolation and approximation.

Extrapolation routines are used to obtain SAR values between the lowest measurement points and the inner phantom surface. The extrapolation distance is determined by the surface detection distance and the probe sensor offset. The uncertainty increases with the extrapolation distance. To keep the uncertainty within 1% for the 1 g and 10 g cubes, the extrapolation distance should not be larger than 5 mm.

4. SAR Measurement Evaluation

4.1 EUT Configuration and Setting

For WLAN SAR testing, the EUT has installed WLAN engineering testing software which can provide continuous transmitting RF signal. This RF signal utilized in SAR measurement has almost 100% duty cycle. The data rates for WLAN SAR testing were set in 1 Mbps for 802.11b, 6 Mbps for 802.11a, and MCS0 for 802.11n HT20 due to the highest RF output power.

4.2 EUT Testing Position

This EUT was tested in **Right Cheek, Right Tilted, Left Cheek, Left Tilted, Front Face, and Rear Face** positions as illustrated below:

1. Define two imaginary lines on the handset

- (a) The vertical centerline passes through two points on the front side of the handset - the midpoint of the width w_t of the handset at the level of the acoustic output, and the midpoint of the width w_b of the bottom of the handset.
- (b) The horizontal line is perpendicular to the vertical centerline and passes through the center of the acoustic output. The horizontal line is also tangential to the face of the handset at point A.
- (c) The two lines intersect at point A. Note that for many handsets, point A coincides with the center of the acoustic output; however, the acoustic output may be located elsewhere on the horizontal line. Also note that the vertical centerline is not necessarily parallel to the front face of the handset, especially for clamshell handsets, handsets with flip covers, and other irregularly shaped handsets.

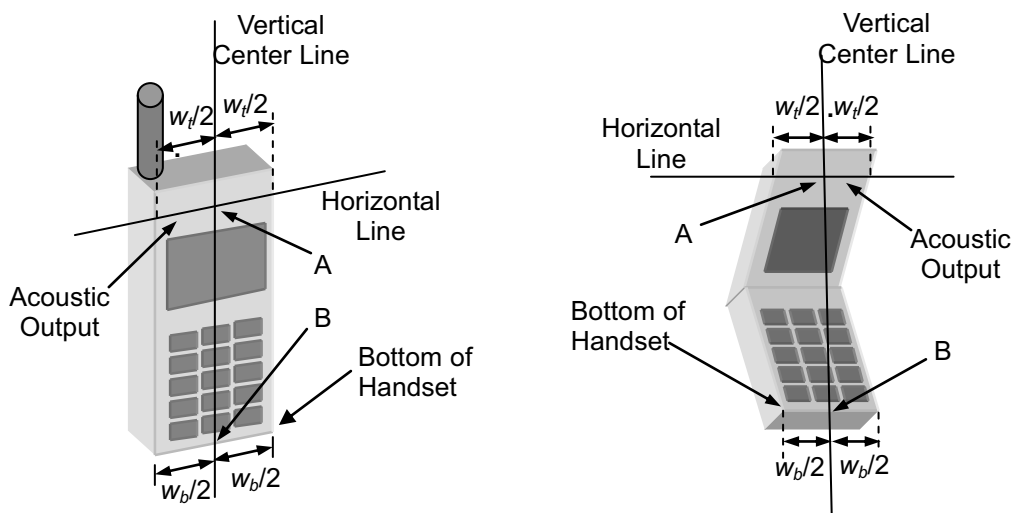

Fig-4.1 Illustration for Handset Vertical and Horizontal Reference Lines

FCC SAR Test Report

2. Cheek Position

- (a) To position the device with the vertical center line of the body of the device and the horizontal line crossing the center piece in a plane parallel to the sagittal plane of the phantom. While maintaining the device in this plane, align the vertical center line with the reference plane containing the three ear and mouth reference point (M: Mouth, RE: Right Ear, and LE: Left Ear) and align the center of the ear piece with the line RE-LE.
- (b) To move the device towards the phantom with the ear piece aligned with the line LE-RE until the phone touched the ear. While maintaining the device in the reference plane and maintaining the phone contact with the ear, move the bottom of the phone until any point on the front side is in contact with the cheek of the phantom or until contact with the ear is lost (see Fig-4.2).

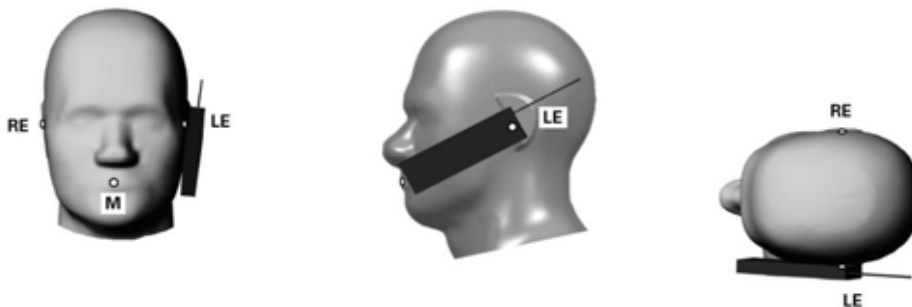

Fig-4.2 Illustration for Cheek Position

3. Tilted Position

- (a) To position the device in the “cheek” position described above.
- (b) While maintaining the device the reference plane described above and pivoting against the ear, moves it outward away from the mouth by an angle of 15 degrees or until contact with the ear is lost (see Fig-4.3).

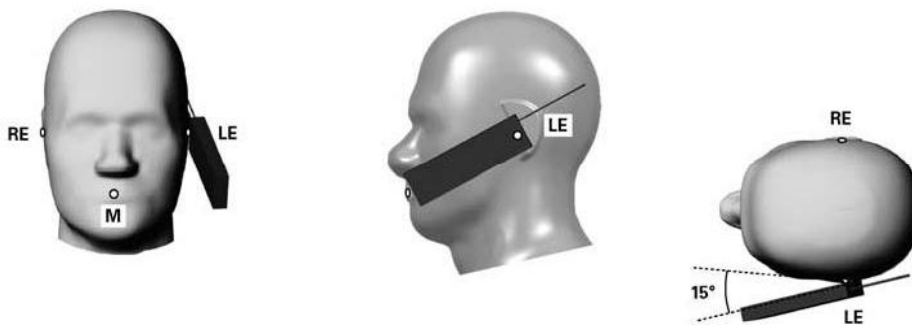

Fig-4.3 Illustration for Tilted Position

FCC SAR Test Report

4. Body Worn Position

- (a) To position the EUT parallel to the phantom surface.
- (b) To adjust the EUT parallel to the flat phantom.
- (c) To adjust the distance between the EUT surface and the flat phantom to 1.5 cm or holster surface and the flat phantom to 0 cm.

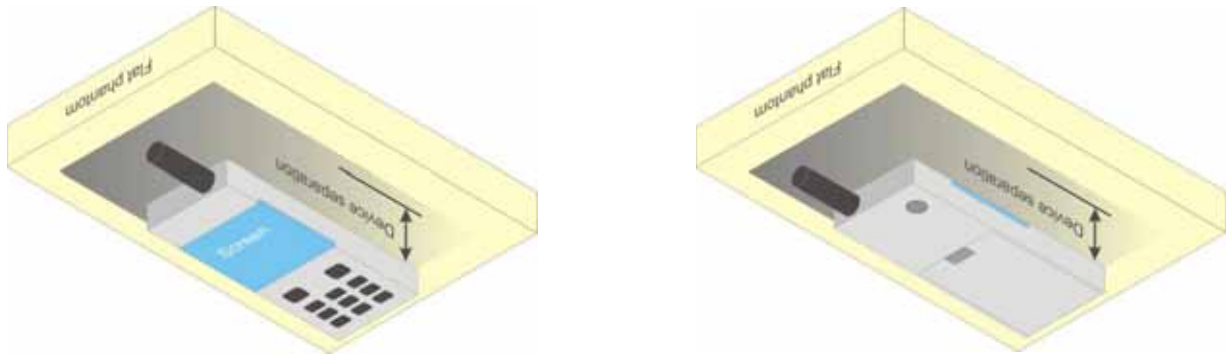

Fig-4.4 Illustration for Body Worn Position

4.3 Tissue Verification

The measuring results for tissue simulating liquid are shown as below.

Tissue Type	Frequency (MHz)	Liquid Temp. (°C)	Measured Conductivity (σ)	Measured Permittivity (ϵ_r)	Target Conductivity (σ)	Target Permittivity (ϵ_r)	Conductivity Deviation (%)	Permittivity Deviation (%)	Test Date
H2450	2450	20.5	1.78	40.30	1.80	39.2	-1.11	2.81	Aug. 16, 2012
H5G	5200	20.2	4.742	37.162	4.66	36.0	1.76	3.23	Aug. 11, 2012
H5G	5200	20.3	4.688	36.999	4.66	36.0	0.60	2.78	Aug. 12, 2012
H5G	5500	20.3	5.065	36.364	4.96	35.6	2.12	2.15	Aug. 12, 2012
H5G	5500	20.4	5.059	36.34	4.96	35.6	2.00	2.08	Aug. 13, 2012
H5G	5800	20.2	5.415	35.658	5.27	35.3	2.75	1.01	Aug. 14, 2012
B2450	2450	20.5	2.01	52.80	1.95	52.7	3.08	0.19	Aug. 15, 2012
B2450	2450	20.5	1.971	51.743	1.95	52.7	1.08	-1.82	Aug. 23, 2012
B5G	5200	20.2	5.28	49.20	5.30	49.0	-0.38	0.41	Aug. 15, 2012
B5G	5200	20.6	5.237	51.076	5.30	49.0	-1.19	4.24	Aug. 21, 2012
B5G	5200	20.6	5.266	49.215	5.30	49.0	-0.64	0.44	Aug. 23, 2012
B5G	5500	20.4	5.706	48.521	5.65	48.6	0.99	-0.16	Aug. 24, 2012
B5G	5800	20.4	6.118	47.772	6.00	48.2	1.97	-0.89	Aug. 24, 2012

Note:

The dielectric properties of the tissue simulating liquid must be measured within 24 hours before the SAR testing and within $\pm 5\%$ of the target values. Liquid temperature during the SAR testing must be within $\pm 2^\circ\text{C}$.



FCC SAR Test Report

A D T

4.4 System Verification

The measuring results for system check are shown as below.

Test Date	Mode	Frequency (MHz)	1W Target SAR-1g (W/kg)	Measured SAR-1g (W/kg)	Normalized to 1W SAR-1g (W/kg)	Deviation (%)	Dipole S/N	Probe S/N	DAE S/N
Aug. 16, 2012	Head	2450	52.90	13.10	52.40	-0.95	737	3650	1277
Aug. 11, 2012	Head	5200	79.60	8.23	82.30	3.39	1018	3590	579
Aug. 12, 2012	Head	5200	79.60	7.64	76.40	-4.02	1018	3590	579
Aug. 12, 2012	Head	5500	84.70	8.53	85.30	0.71	1018	3590	579
Aug. 13, 2012	Head	5500	84.70	8.52	85.20	0.59	1018	3590	579
Aug. 14, 2012	Head	5800	78.60	7.68	76.80	-2.29	1018	3590	579
Aug. 15, 2012	Body	2450	50.00	12.70	50.80	1.60	737	3650	1277
Aug. 23, 2012	Body	2450	50.00	12.20	48.80	-2.40	737	3864	1277
Aug. 15, 2012	Body	5200	72.70	7.26	72.60	-0.14	1018	3650	1277
Aug. 21, 2012	Body	5200	72.70	7.52	75.20	3.44	1018	3650	910
Aug. 23, 2012	Body	5200	72.70	7.48	74.80	2.89	1018	3590	579
Aug. 24, 2012	Body	5500	78.30	7.69	76.90	-1.79	1018	3590	579
Aug. 24, 2012	Body	5800	73.40	7.70	77.00	4.90	1018	3590	579

Note:

Comparing to the reference SAR value provided by SPEAG, the validation data should be within its specification of 10 %. The result indicates the system check can meet the variation criterion and the plots can be referred to Appendix A of this report.



FCC SAR Test Report

4.5 Conducted Power Results

The measuring conducted power (Unit: dBm) are shown as below.

<EUT without MSR>

Band	802.11b					802.11g				
Channel	1	6	11	12	13	1	6	11	12	13
Frequency (MHz)	2412	2437	2462	2467	2472	2412	2437	2462	2467	2472
Average Power (Ant-0)	22.59	22.49	22.39	-15.5	-15.6	18.35	22.60	17.72	-15.91	-15.75
Average Power (Ant-1)	22.43	22.28	21.76	-15.5	-15.72	21.62	21.90	17.39	-16.44	-16.39

Band	802.11n (HT20)					-				
Channel	1	6	11	12	13	-	-	-	-	-
Frequency (MHz)	2412	2437	2462	2467	2472	-	-	-	-	-
Average Power (Ant-0)	17.91	21.89	18.10	-16.01	-15.93	-	-	-	-	-
Average Power (Ant-1)	18.10	21.85	17.24	-16.4	-16.69	-	-	-	-	-

Band	802.11a							
Channel	36	40	44	48	52	56	60	64
Frequency (MHz)	5180	5200	5220	5240	5260	5280	5300	5320
Average Power (Ant-0)	13.22	13.19	13.29	13.39	18.34	18.39	18.50	18.52
Average Power (Ant-1)	13.22	13.21	13.21	13.39	19.00	19.25	19.22	19.31

Band	802.11a							
Channel	100	104	108	112	116	132	136	140
Frequency (MHz)	5500	5520	5540	5560	5580	5660	5680	5700
Average Power (Ant-0)	17.20	19.06	18.96	19.00	19.15	19.02	18.63	17.08
Average Power (Ant-1)	17.20	19.06	18.86	18.61	19.15	18.93	18.63	17.08

Band	802.11a							
Channel	149	153	157	161	165	-	-	-
Frequency (MHz)	5745	5765	5785	5805	5825	-	-	-
Average Power (Ant-0)	19.02	18.91	18.96	18.93	18.92	-	-	-
Average Power (Ant-1)	17.52	17.45	17.46	17.47	17.42	-	-	-

Band	802.11n (HT20)							
Channel	36	40	44	48	52	56	60	64
Frequency (MHz)	5180	5200	5220	5240	5260	5280	5300	5320
Average Power (Ant-0)	13.30	13.32	13.20	13.36	17.81	17.92	18.02	17.85
Average Power (Ant-1)	13.25	13.14	13.14	13.34	18.19	18.41	18.24	18.48

Band	802.11n (HT20)							
Channel	100	104	108	112	116	132	136	140
Frequency (MHz)	5500	5520	5540	5560	5580	5660	5680	5700
Average Power (Ant-0)	17.42	18.63	18.66	18.60	18.68	18.41	18.32	16.94
Average Power (Ant-1)	17.31	18.42	18.39	18.38	18.64	18.37	18.22	17.04

Band	802.11n (HT20)							
Channel	149	153	157	161	165	-	-	-
Frequency (MHz)	5745	5765	5785	5805	5825	-	-	-
Average Power (Ant-0)	18.50	18.45	18.46	18.43	18.42	-	-	-
Average Power (Ant-1)	18.92	18.82	18.88	18.85	18.92	-	-	-



FCC SAR Test Report

A D T

<EUT with MSR>

Band	802.11b					802.11g				
Channel	1	6	11	12	13	1	6	11	12	13
Frequency (MHz)	2412	2437	2462	2467	2472	2412	2437	2462	2467	2472
Average Power (Ant-0)	22.23	22.21	19.47	-15.63	-15.65	18.13	21.97	16.31	-16.02	-15.86
Average Power (Ant-1)	22.43	22.28	21.76	-15.5	-15.72	21.62	21.90	17.39	-16.44	-16.39

Band	802.11n (HT20)					-				
Channel	1	6	11	12	13	-	-	-	-	-
Frequency (MHz)	2412	2437	2462	2467	2472	-	-	-	-	-
Average Power (Ant-0)	17.43	21.89	15.65	-16.11	-15.99	-	-	-	-	-
Average Power (Ant-1)	18.10	21.85	17.24	-16.4	-16.69	-	-	-	-	-

Band	802.11a							
Channel	36	40	44	48	52	56	60	64
Frequency (MHz)	5180	5200	5220	5240	5260	5280	5300	5320
Average Power (Ant-0)	13.29	13.36	13.34	13.58	18.64	18.63	18.68	18.71
Average Power (Ant-1)	13.22	13.21	12.92	13.39	19.00	19.25	19.22	19.31

Band	802.11a							
Channel	100	104	108	112	116	132	136	140
Frequency (MHz)	5500	5520	5540	5560	5580	5660	5680	5700
Average Power (Ant-0)	17.03	19.01	18.67	18.73	18.99	18.79	18.54	16.95
Average Power (Ant-1)	17.20	19.06	18.86	18.61	19.15	18.93	18.63	17.08

Band	802.11a							
Channel	149	153	157	161	165	-	-	-
Frequency (MHz)	5745	5765	5785	5805	5825	-	-	-
Average Power (Ant-0)	18.94	18.88	18.96	18.84	18.91	-	-	-
Average Power (Ant-1)	17.52	17.45	17.46	17.47	17.42	-	-	-

Band	802.11n (HT20)							
Channel	36	40	44	48	52	56	60	64
Frequency (MHz)	5180	5200	5220	5240	5260	5280	5300	5320
Average Power (Ant-0)	13.50	13.49	13.43	13.52	18.15	18.21	18.24	18.11
Average Power (Ant-1)	13.25	13.14	13.09	13.34	18.19	18.41	18.24	18.48

Band	802.11n (HT20)							
Channel	100	104	108	112	116	132	136	140
Frequency (MHz)	5500	5520	5540	5560	5580	5660	5680	5700
Average Power (Ant-0)	16.93	18.07	18.02	17.96	18.11	18.05	18.03	16.93
Average Power (Ant-1)	17.31	18.42	18.39	18.38	18.64	18.37	18.22	17.04

Band	802.11n (HT20)							
Channel	149	153	157	161	165	-	-	-
Frequency (MHz)	5745	5765	5785	5805	5825	-	-	-
Average Power (Ant-0)	18.53	18.34	18.48	18.45	18.41	-	-	-
Average Power (Ant-1)	18.92	18.82	18.88	18.85	18.92	-	-	-



FCC SAR Test Report

4.6 SAR Testing Results

4.6.1 SAR Results for Head

Plot No.	Band	Mode	Test Position	Channel	MSR	Tx Antenna	SAR-1g (W/kg)
1	802.11b	-	Right Cheek	1	w/o	0	0.189
2	802.11b	-	Right Cheek	1	w/	0	0.068
3	802.11b	-	Right Tilted	1	w/o	0	0.102
4	802.11b	-	Left Cheek	1	w/o	0	0.11
5	802.11b	-	Left Tilted	1	w/o	0	0.107
137	802.11b	-	Right Cheek	1	w/o	1	0.165
138	802.11b	-	Right Cheek	1	w/	1	0.257
139	802.11b	-	Right Tilted	1	w/	1	0.111
140	802.11b	-	Left Cheek	1	w/	1	0.182
141	802.11b	-	Left Tilted	1	w/	1	0.11
15	802.11a	-	Right Cheek	48	w/o	0	N/A
16	802.11a	-	Right Cheek	48	w/	0	0.000225
17	802.11a	-	Right Tilted	48	w/	0	0.000117
18	802.11a	-	Left Cheek	48	w/	0	0.00564
19	802.11a	-	Left Tilted	48	w/	0	0.00288
21	802.11a	-	Right Cheek	48	w/o	1	0.0000166
22	802.11a	-	Right Cheek	48	w/	1	0.00103
23	802.11a	-	Right Tilted	48	w/	1	0.000268
24	802.11a	-	Left Cheek	48	w/	1	0.019
25	802.11a	-	Left Tilted	48	w/	1	0.000118
27	802.11a	-	Right Cheek	64	w/o	0	N/A
28	802.11a	-	Right Cheek	64	w/	0	0.014
29	802.11a	-	Right Tilted	64	w/	0	0.00707
30	802.11a	-	Left Cheek	64	w/	0	0.00246
31	802.11a	-	Left Tilted	64	w/	0	0.012
33	802.11a	-	Right Cheek	64	w/o	1	0.014
34	802.11a	-	Right Cheek	64	w/	1	0.0000522
35	802.11a	-	Right Tilted	64	w/o	1	0.00173
36	802.11a	-	Left Cheek	64	w/o	1	0.00194
37	802.11a	-	Left Tilted	64	w/o	1	0.00794
39	802.11a	-	Right Cheek	116	w/o	0	N/A
40	802.11a	-	Right Cheek	104	w/	0	0.0000353
41	802.11a	-	Right Tilted	104	w/	0	0.0093
42	802.11a	-	Left Cheek	104	w/	0	0.00109
43	802.11a	-	Left Tilted	104	w/	0	0.00039
46	802.11a	-	Right Cheek	116	w/o	1	0.03
47	802.11a	-	Right Cheek	116	w/	1	0.045
48	802.11a	-	Right Tilted	116	w/	1	0.0000187
49	802.11a	-	Left Cheek	116	w/	1	0.0033
50	802.11a	-	Left Tilted	116	w/	1	0.000411
53	802.11a	-	Right Cheek	149	w/o	0	0.00208
54	802.11a	-	Right Cheek	157	w/	0	0.000762
55	802.11a	-	Right Tilted	149	w/o	0	0.00000406
56	802.11a	-	Left Cheek	149	w/o	0	0.0000409
57	802.11a	-	Left Tilted	149	w/o	0	0.00118
60	802.11a	HT20	Right Cheek	149	w/o	1	0.092
61	802.11a	HT20	Right Cheek	149	w/	1	0.147
62	802.11a	HT20	Right Tilted	149	w/	1	0.033
63	802.11a	HT20	Left Cheek	149	w/	1	0.037
64	802.11a	HT20	Left Tilted	149	w/	1	0.00314



FCC SAR Test Report

Note:

1. SAR is performed on the highest power channel. When the SAR value of highest power channel is less than 0.8 W/kg, SAR testing for optional channel is not required.
2. Since WLAN of this device supports VOIP capability through 3rd party apps software, we have evaluated data mode for head SAR.
3. SAR testing for 802.11g/n is not required because its maximum power is less than 1/4 dB higher than 802.11b.
4. SAR testing for WLAN 5G is performed on the maximum power mode.
5. The "N/A" means there is no SAR value or the SAR is too low to be measured.
6. SAR Test reduction has got the opinion from FCC through KDB 428320.



FCC SAR Test Report

4.6.2 SAR Results for Body

Plot No.	Band	Mode	Test Position	Separation Distance (cm)	Channel	MSR	Tx Antenna	Earphone	Holster	SAR-1g (W/kg)
67	802.11b	-	Front Face	1.5	1	w/o	0	w/	w/o	0.037
68	802.11b	-	Front Face	1.5	1	w/	0	w/	w/o	0.00602
69	802.11b	-	Rear Face	1.5	1	w/o	0	w/	w/o	0.161
135	802.11b	-	Front Face	1.5	1	w/o	1	w/	w/o	0.026
136	802.11b	-	Front Face	1.5	1	w/	1	w/	w/o	0.018
134	802.11b	-	Rear Face	1.5	1	w/o	1	w/	w/o	0.16
77	802.11b	-	Front Face	0	1	w/o	0	w/o	w/	0.019
78	802.11b	-	Rear Face	0	1	w/o	0	w/o	w/	0.28
81	802.11a	-	Front Face	1.5	48	w/o	0	w/	w/o	0.000195
82	802.11a	-	Front Face	1.5	48	w/	0	w/	w/o	N/A
83	802.11a	-	Rear Face	1.5	48	w/o	0	w/	w/o	0.178
85	802.11a	-	Front Face	1.5	48	w/o	1	w/	w/o	0.00164
86	802.11a	-	Front Face	1.5	48	w/	1	w/	w/o	0.019
87	802.11a	-	Rear Face	1.5	48	w/	1	w/	w/o	0.185
89	802.11a	-	Front Face	0	48	w/	1	w/o	w/	0.012
90	802.11a	-	Rear Face	0	48	w/	1	w/o	w/	0.267
92	802.11a	-	Front Face	1.5	64	w/o	0	w/	w/o	0.026
93	802.11a	-	Front Face	1.5	64	w/	0	w/	w/o	0.00539
94	802.11a	-	Rear Face	1.5	64	w/o	0	w/	w/o	0.26
96	802.11a	-	Front Face	1.5	64	w/o	1	w/	w/o	0.017
97	802.11a	-	Front Face	1.5	64	w/	1	w/	w/o	0.02
98	802.11a	-	Rear Face	1.5	64	w/	1	w/	w/o	0.197
100	802.11a	-	Front Face	0	64	w/o	0	w/o	w/	0.015
101	802.11a	-	Rear Face	0	64	w/o	0	w/o	w/	0.122
103	802.11a	-	Front Face	1.5	116	w/o	0	w/	w/o	0.041
104	802.11a	-	Front Face	1.5	104	w/	0	w/	w/o	0.000963
105	802.11a	-	Rear Face	1.5	116	w/o	0	w/	w/o	0.663
108	802.11a	-	Front Face	1.5	116	w/o	1	w/	w/o	0.00673
109	802.11a	-	Front Face	1.5	116	w/	1	w/	w/o	0.012
110	802.11a	-	Rear Face	1.5	116	w/	1	w/	w/o	0.512
113	802.11a	-	Front Face	0	116	w/o	0	w/o	w/	0.014
114	802.11a	-	Rear Face	0	116	w/o	0	w/o	w/	0.222
117	802.11a	-	Front Face	1.5	149	w/o	0	w/	w/o	0.024
118	802.11a	-	Front Face	1.5	157	w/	0	w/	w/o	0.00185
119	802.11a	-	Rear Face	1.5	149	w/o	0	w/	w/o	0.527
122	802.11a	HT20	Front Face	1.5	149	w/o	1	w/	w/o	0.035
123	802.11a	HT20	Front Face	1.5	149	w/	1	w/	w/o	0.084
124	802.11a	HT20	Rear Face	1.5	149	w/	1	w/	w/o	0.564
127	802.11a	HT20	Front Face	0	149	w/	1	w/o	w/	0.021
128	802.11a	HT20	Rear Face	0	149	w/	1	w/o	w/	0.505

Note:

- SAR is performed on the highest power channel. When the SAR value of highest power channel is less than 0.8 W/kg, SAR testing for optional channel is not required.
- Since WLAN of this device supports VOIP capability through 3rd party apps software, we have evaluated data mode for body worn mode.
- SAR testing for 802.11g/n is not required because its maximum power is less than 1/4 dB higher than 802.11b.
- SAR testing for WLAN 5G is performed on the maximum power mode.
- The "N/A" means there is no SAR value or the SAR is too low to be measured.
- SAR Test reduction has got the opinion from FCC through KDB 428320.

Test Engineer : Mars Chang, and Hank Wu



5. Calibration of Test Equipment

Equipment	Manufacturer	Model	SN	Cal. Date	Cal. Interval
System Validation Kit	SPEAG	D2450V2	737	Jan. 24, 2012	Annual
System Validation Kit	SPEAG	D5GHzV2	1018	Jan. 18, 2012	Annual
Dosimetric E-Field Probe	SPEAG	EX3DV4	3590	Feb. 23, 2012	Annual
Dosimetric E-Field Probe	SPEAG	EX3DV4	3650	Oct. 26, 2011	Annual
Dosimetric E-Field Probe	SPEAG	EX3DV4	3864	Jul. 19, 2012	Annual
Data Acquisition Electronics	SPEAG	DAE3	579	Apr. 27, 2012	Annual
Data Acquisition Electronics	SPEAG	DAE4	910	Dec. 07, 2011	Annual
Data Acquisition Electronics	SPEAG	DAE4	1277	Jul. 19, 2012	Annual
SAM Phantom	SPEAG	QD000P40CD	TP-1652	N/A	N/A
SAM Phantom	SPEAG	QD000P40CD	TP-1654	N/A	N/A
SAM Phantom	SPEAG	QD000P40CD	TP-1653	N/A	N/A
ENA Series Network Analyzer	Agilent	E5071C	MY46214281	May 14, 2012	Annual
MXG Analog Signal Generator	Agilent	N5181A	MY50143868	May 06, 2012	Annual
Power Meter	Anritsu	ML2495A	1218009	May 07, 2012	Annual
Power Sensor	Anritsu	MA2411B	1207252	May 07, 2012	Annual
EXA Spectrum Analyzer	Agilent	N9010A	MY52100136	Apr. 23, 2012	Annual
Dielectric Probe Kit	Agilent	85070D	E2-020018	May 14, 2012	Annual
Thermometer	YFE	YF-160A	110600361	Feb. 21, 2012	Annual
Directional Coupler	Woken	0110A056020-10	11122702	Apr. 19, 2012	Annual
Power Amplifier	AR	5S1G4	0339656	Apr. 23, 2012	Annual
Power Amplifier	Mini-Circuit	ZVE-8G	001000422	Apr. 23, 2012	Annual
Attenuator	Woken	00800A1G01L-03	N/A	Apr. 19, 2012	Annual



FCC SAR Test Report

6. Measurement Uncertainty

Error Description	Uncertainty Value (±%)	Probability Distribution	Divisor	C _i (1g)	Standard Uncertainty (1g)	V _i
Measurement System						
Probe Calibration	6.0	Normal	1	1	± 6.0 %	∞
Axial Isotropy	4.7	Rectangular	√3	0.7	± 1.9 %	∞
Hemispherical Isotropy	9.6	Rectangular	√3	0.7	± 3.9 %	∞
Boundary Effects	1.0	Rectangular	√3	1	± 0.6 %	∞
Linearity	4.7	Rectangular	√3	1	± 2.7 %	∞
System Detection Limits	1.0	Rectangular	√3	1	± 0.6 %	∞
Readout Electronics	0.6	Normal	1	1	± 0.6 %	∞
Response Time	0.0	Rectangular	√3	1	± 0.0 %	∞
Integration Time	1.7	Rectangular	√3	1	± 1.0 %	∞
RF Ambient Noise	3.0	Rectangular	√3	1	± 1.7 %	∞
RF Ambient Reflections	3.0	Rectangular	√3	1	± 1.7 %	∞
Probe Positioner	0.5	Rectangular	√3	1	± 0.3 %	∞
Probe Positioning	2.9	Rectangular	√3	1	± 1.7 %	∞
Max. SAR Eval.	2.3	Rectangular	√3	1	± 1.3 %	∞
Test Sample Related						
Device Positioning	3.9	Normal	1	1	± 3.9 %	31
Device Holder	2.7	Normal	1	1	± 2.7 %	19
Power Drift	5.0	Rectangular	√3	1	± 2.9 %	∞
Phantom and Setup						
Phantom Uncertainty	4.0	Rectangular	√3	1	± 2.3 %	∞
Liquid Conductivity (Target)	5.0	Rectangular	√3	0.64	± 1.8 %	∞
Liquid Conductivity (Meas.)	5.0	Normal	1	0.64	± 3.2 %	29
Liquid Permittivity (Target)	5.0	Rectangular	√3	0.6	± 1.7 %	∞
Liquid Permittivity (Meas.)	5.0	Normal	1	0.6	± 3.0 %	29
Combined Standard Uncertainty					± 11.7 %	
Expanded Uncertainty (K=2)					± 23.4 %	

Uncertainty budget for frequency range 300 MHz to 3 GHz



FCC SAR Test Report

Error Description	Uncertainty Value (±%)	Probability Distribution	Divisor	Ci (1g)	Standard Uncertainty (1g)	Vi
Measurement System						
Probe Calibration	6.55	Normal	1	1	± 6.55 %	∞
Axial Isotropy	4.7	Rectangular	√3	0.7	± 1.9 %	∞
Hemispherical Isotropy	9.6	Rectangular	√3	0.7	± 3.9 %	∞
Boundary Effects	2.0	Rectangular	√3	1	± 1.2 %	∞
Linearity	4.7	Rectangular	√3	1	± 2.7 %	∞
System Detection Limits	1.0	Rectangular	√3	1	± 0.6 %	∞
Readout Electronics	0.3	Normal	1	1	± 0.3 %	∞
Response Time	0.8	Rectangular	√3	1	± 0.5 %	∞
Integration Time	2.6	Rectangular	√3	1	± 1.5 %	∞
RF Ambient Noise	3.0	Rectangular	√3	1	± 1.7 %	∞
RF Ambient Reflections	3.0	Rectangular	√3	1	± 1.7 %	∞
Probe Positioner	0.8	Rectangular	√3	1	± 0.5 %	∞
Probe Positioning	9.9	Rectangular	√3	1	± 5.7 %	∞
Max. SAR Eval.	4.0	Rectangular	√3	1	± 2.3 %	∞
Test Sample Related						
Device Positioning	3.9	Normal	1	1	± 3.9 %	31
Device Holder	2.7	Normal	1	1	± 2.7 %	19
Power Drift	5.0	Rectangular	√3	1	± 2.9 %	∞
Phantom and Setup						
Phantom Uncertainty	4.0	Rectangular	√3	1	± 2.3 %	∞
Liquid Conductivity (Target)	5.0	Rectangular	√3	0.64	± 1.8 %	∞
Liquid Conductivity (Meas.)	5.0	Normal	1	0.64	± 3.2 %	30
Liquid Permittivity (Target)	5.0	Rectangular	√3	0.6	± 1.7 %	∞
Liquid Permittivity (Meas.)	5.0	Normal	1	0.6	± 3.0 %	30
Combined Standard Uncertainty					± 13.4 %	
Expanded Uncertainty (K=2)					± 26.8 %	

Uncertainty budget for frequency range 3 GHz to 6 GHz



7. Information on the Testing Laboratories

We, Bureau Veritas Consumer Products Services (H.K.) Ltd., Taoyuan Branch, were founded in 1988 to provide our best service in EMC, Radio, Telecom and Safety consultation. Our laboratories are accredited and approved according to ISO/IEC 17025.

If you have any comments, please feel free to contact us at the following:

Taiwan HwaYa EMC/RF/Safety/Telecom Lab:

Add: No. 19, Hwa Ya 2nd Rd, Wen Hwa Vil., Kwei Shan Hsiang, Taoyuan Hsien 333, Taiwan, R.O.C.
Tel: 886-3-318-3232
Fax: 886-3-327-0892

Taiwan LinKo EMC/RF Lab:

Add: No. 47, 14th Ling, Chia Pau Vil., Linkou Dist., New Taipei City 244, Taiwan, R.O.C.
Tel: 886-2-2605-2180
Fax: 886-2-2605-1924

Taiwan HsinChu EMC/RF Lab:

Add: No. 81-1, Lu Liao Keng, 9th Ling, Wu Lung Vil., Chiung Lin Township, Hsinchu County 307, Taiwan, R.O.C.
Tel: 886-3-593-5343
Fax: 886-3-593-5342

Email: service.adt@tw.bureauveritas.com

Web Site: www.adt.com.tw

The road map of all our labs can be found in our web site also.

---END---



Appendix A. SAR Plots of System Verification

The plots for system verification are shown as follows.

System Check_H2450_120816

DUT: Dipole 2450 MHz; Type: D2450V2; SN: 737

Communication System: CW; Frequency: 2450 MHz; Duty Cycle: 1:1

Medium: H2450_0816 Medium parameters used: $f = 2450$ MHz; $\sigma = 1.78$ mho/m; $\epsilon_r = 40.3$; $\rho = 1000$ kg/m³

Ambient Temperature : 21.6 °C ; Liquid Temperature : 20.5 °C

DASY4 Configuration:

- Probe: EX3DV4 - SN3650; ConvF(6.8, 6.8, 6.8); Calibrated: 2011/10/26
- Sensor-Surface: 2mm (Mechanical Surface Detection)
- Electronics: DAE4 Sn1277; Calibrated: 2012/07/19
- Phantom: SAM Phantom_Left; Type: SAM V4.0; Serial: TP 1652
- Measurement SW: DASY4, V4.7 Build 80; Postprocessing SW: SEMCAD, V1.8 Build 186

Pin=250mW/Area Scan (61x61x1): Measurement grid: dx=15mm, dy=15mm

Maximum value of SAR (interpolated) = 22.3 mW/g

Pin=250mW/Zoom Scan (5x5x7)/Cube 0: Measurement grid: dx=8mm, dy=8mm, dz=5mm

Reference Value = 105.9 V/m; Power Drift = -0.011 dB

Peak SAR (extrapolated) = 28.7 W/kg

SAR(1 g) = 13.1 mW/g; SAR(10 g) = 5.96 mW/g

Maximum value of SAR (measured) = 20.4 mW/g

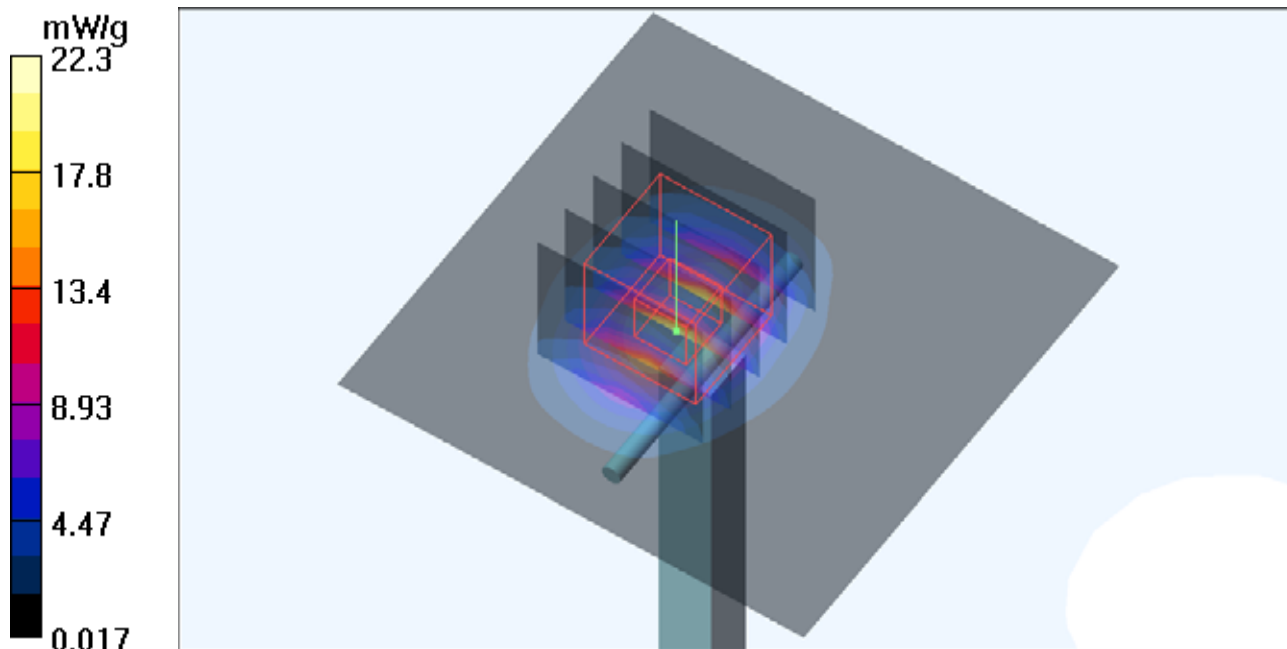

System Check_H5200_120811

DUT: Dipole 5 GHz; Type: D5GHzV2; SN: 1018

Communication System: CW; Frequency: 5200 MHz; Duty Cycle: 1:1

Medium: H5G_0811 Medium parameters used: $f = 5200$ MHz; $\sigma = 4.742$ mho/m; $\epsilon_r = 37.162$; $\rho = 1000$ kg/m³

Ambient Temperature : 21.6 °C ; Liquid Temperature : 20.2 °C

DASY5 Configuration:

- Probe: EX3DV4 - SN3590; ConvF(5.64, 5.64, 5.64); Calibrated: 2012/02/23;
- Sensor-Surface: 2mm (Mechanical Surface Detection)
- Electronics: DAE3 Sn579; Calibrated: 2012/04/27
- Phantom: SAM with CRP v5.0 Front; Type: QD000P40CD; Serial: TP:1653
- Measurement SW: DASY52, Version 52.8 (1); SEMCAD X Version 14.6.5 (6469)

Pin=100mW, f=5200 MHz/Area Scan (91x91x1): Measurement grid: dx=10mm, dy=10mm
Maximum value of SAR (interpolated) = 17.2 mW/g

Pin=100mW, f=5200 MHz/Zoom Scan (7x7x9)/Cube 0: Measurement grid: dx=4mm, dy=4mm, dz=2.5mm

Reference Value = 63.034 V/m; Power Drift = 0.01 dB

Peak SAR (extrapolated) = 35.902 mW/g

SAR(1 g) = 8.23 mW/g; SAR(10 g) = 2.31 mW/g

Maximum value of SAR (measured) = 17.8 mW/g

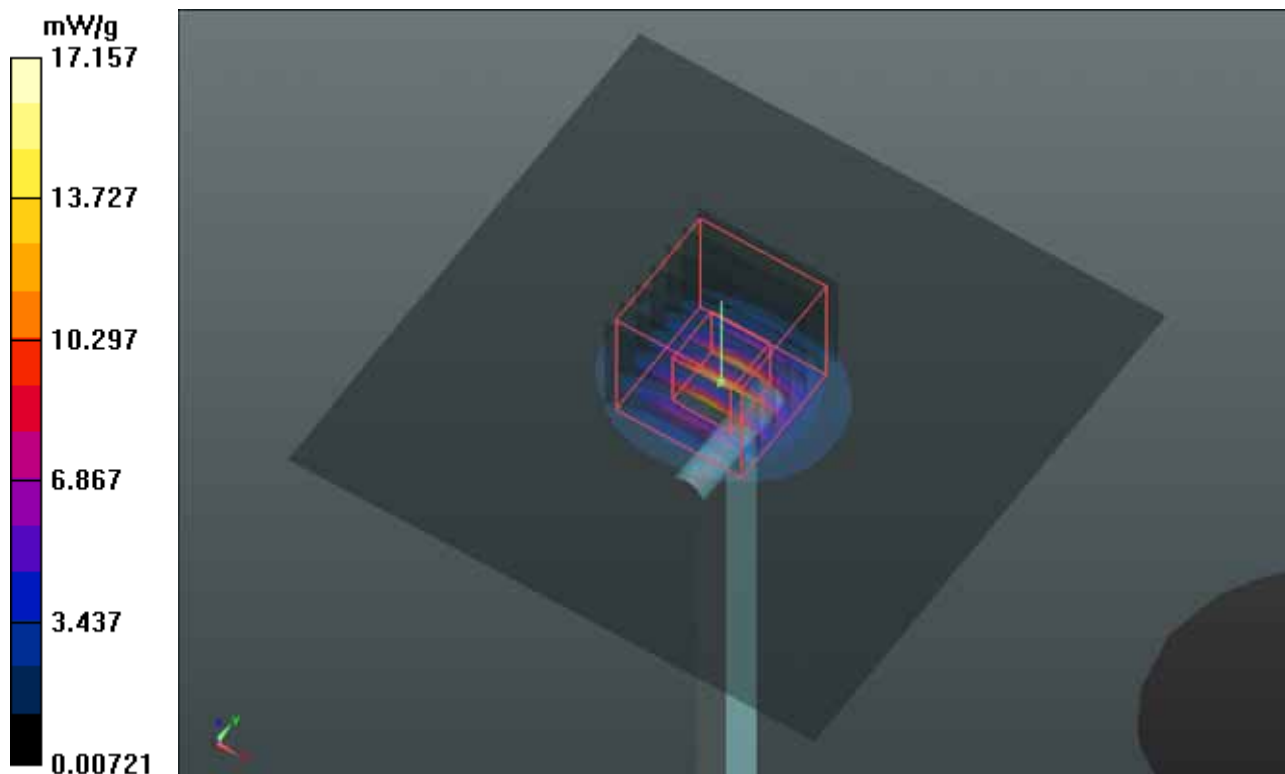

System Check_H5200_120812

DUT: Dipole 5 GHz; Type: D5GHzV2; SN: 1018

Communication System: CW; Frequency: 5200 MHz; Duty Cycle: 1:1

Medium: H5G_0812 Medium parameters used: $f = 5200$ MHz; $\sigma = 4.688$ mho/m; $\epsilon_r = 36.999$; $\rho = 1000$ kg/m³

Ambient Temperature : 21.7 °C ; Liquid Temperature : 20.3 °C

DASY5 Configuration:

- Probe: EX3DV4 - SN3590; ConvF(5.64, 5.64, 5.64); Calibrated: 2012/02/23;
- Sensor-Surface: 2mm (Mechanical Surface Detection)
- Electronics: DAE3 Sn579; Calibrated: 2012/04/27
- Phantom: SAM with CRP v5.0 Front; Type: QD000P40CD; Serial: TP:1653
- Measurement SW: DASY52, Version 52.8 (2); SEMCAD X Version 14.6.6 (6824)

Pin=100mW, f=5200 MHz/Area Scan (91x91x1): Measurement grid: dx=10mm, dy=10mm
Maximum value of SAR (interpolated) = 16.3 W/kg

Pin=100mW, f=5200 MHz/Zoom Scan (7x7x9)/Cube 0: Measurement grid: dx=4mm, dy=4mm, dz=2.5mm

Reference Value = 61.298 V/m; Power Drift = 0.01 dB

Peak SAR (extrapolated) = 32.347 mW/g

SAR(1 g) = 7.64 mW/g; SAR(10 g) = 2.16 mW/g

Maximum value of SAR (measured) = 15.8 W/kg

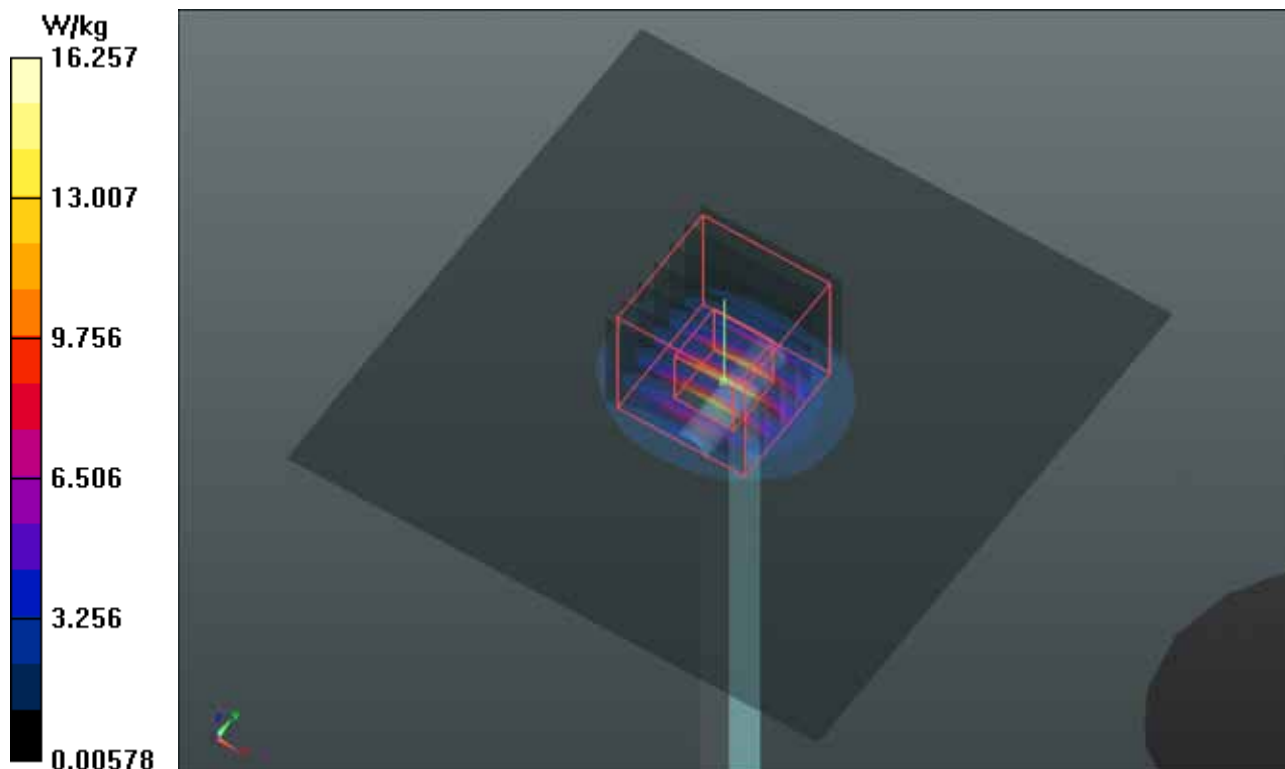

System Check_H5500_120812

DUT: Dipole 5 GHz; Type: D5GHzV2; SN: 1018

Communication System: CW; Frequency: 5500 MHz; Duty Cycle: 1:1

Medium: H5G_0812 Medium parameters used: $f = 5500$ MHz; $\sigma = 5.065$ mho/m; $\epsilon_r = 36.364$; $\rho = 1000$ kg/m³

Ambient Temperature : 21.7 °C ; Liquid Temperature : 20.3 °C

DASY5 Configuration:

- Probe: EX3DV4 - SN3590; ConvF(5.13, 5.13, 5.13); Calibrated: 2012/02/23;
- Sensor-Surface: 2mm (Mechanical Surface Detection)
- Electronics: DAE3 Sn579; Calibrated: 2012/04/27
- Phantom: SAM with CRP v5.0 Front; Type: QD000P40CD; Serial: TP:1653
- Measurement SW: DASY52, Version 52.8 (1); SEMCAD X Version 14.6.5 (6469)

Pin=100mW, f=5500 MHz/Area Scan (91x91x1): Measurement grid: dx=10mm, dy=10mm
Maximum value of SAR (interpolated) = 18.5 mW/g

Pin=100mW, f=5500 MHz/Zoom Scan (7x7x9)/Cube 0: Measurement grid: dx=4mm, dy=4mm, dz=2.5mm

Reference Value = 64.500 V/m; Power Drift = 0.02 dB

Peak SAR (extrapolated) = 38.427 mW/g

SAR(1 g) = 8.53 mW/g; SAR(10 g) = 2.37 mW/g

Maximum value of SAR (measured) = 18.7 mW/g

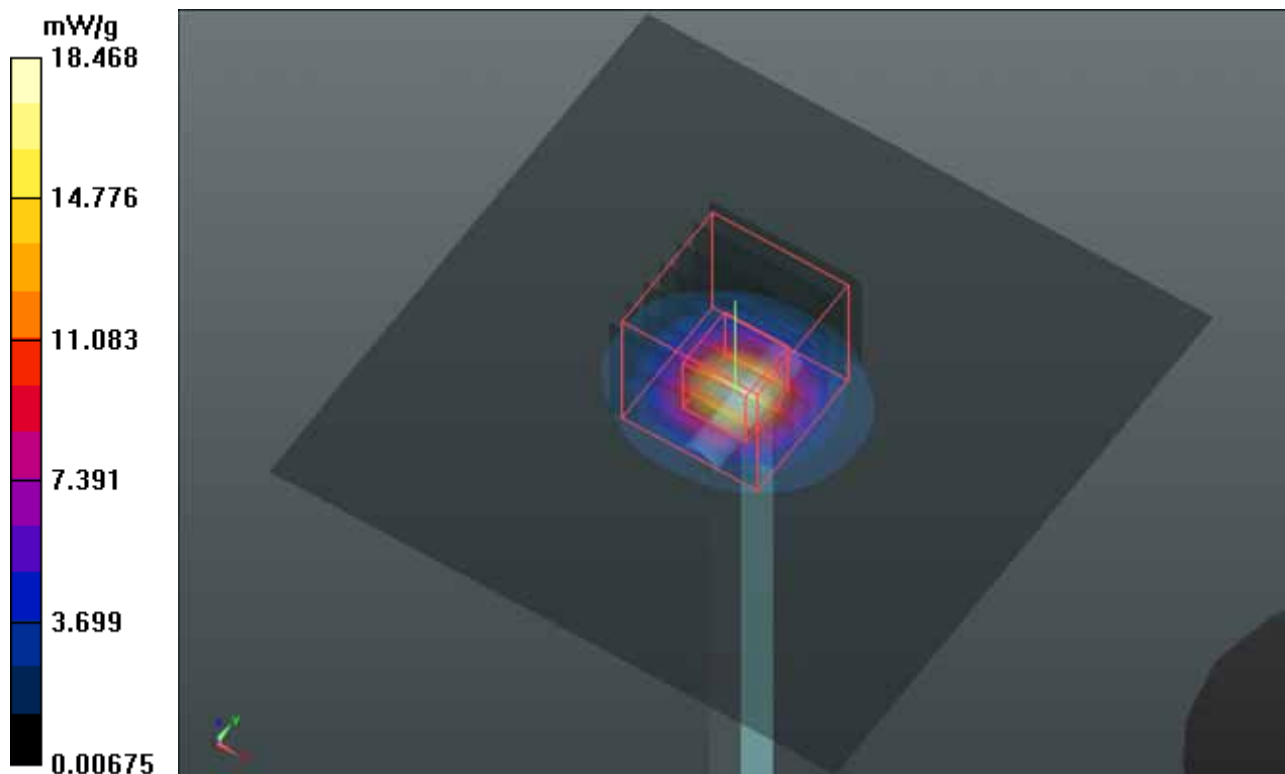

System Check_H5500_120813

DUT: Dipole 5 GHz; Type: D5GHzV2; SN: 1018

Communication System: CW; Frequency: 5500 MHz; Duty Cycle: 1:1

Medium: H5G_0813 Medium parameters used: $f = 5500$ MHz; $\sigma = 5.059$ mho/m; $\epsilon_r = 36.34$; $\rho = 1000$ kg/m³

Ambient Temperature : 21.7 °C ; Liquid Temperature : 20.4 °C

DASY5 Configuration:

- Probe: EX3DV4 - SN3590; ConvF(5.13, 5.13, 5.13); Calibrated: 2012/02/23;
- Sensor-Surface: 2mm (Mechanical Surface Detection)
- Electronics: DAE3 Sn579; Calibrated: 2012/04/27
- Phantom: SAM with CRP v5.0 Front; Type: QD000P40CD; Serial: TP:1653
- Measurement SW: DASY52, Version 52.8 (2); SEMCAD X Version 14.6.6 (6824)

Pin=100mW, f=5500 MHz/Area Scan (91x91x1): Measurement grid: dx=10mm, dy=10mm
Maximum value of SAR (interpolated) = 18.4 W/kg

Pin=100mW, f=5500 MHz/Zoom Scan (7x7x9)/Cube 0: Measurement grid: dx=4mm, dy=4mm, dz=2.5mm
Reference Value = 64.500 V/m; Power Drift = 0.02 dB
Peak SAR (extrapolated) = 38.387 mW/g
SAR(1 g) = 8.52 mW/g; SAR(10 g) = 2.36 mW/g
Maximum value of SAR (measured) = 18.6 W/kg

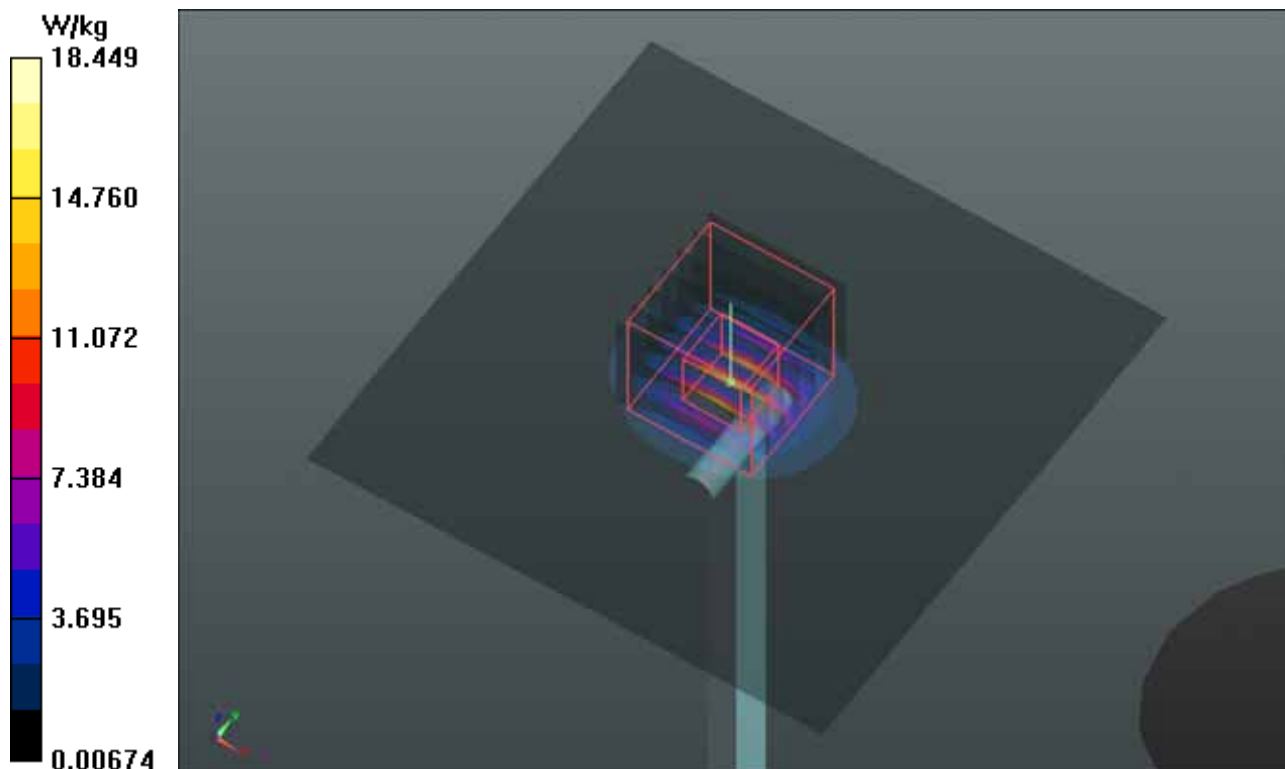

System Check_H5800_120814

DUT: Dipole 5 GHz; Type: D5GHzV2; SN: 1018

Communication System: CW; Frequency: 5800 MHz; Duty Cycle: 1:1

Medium: H5G_0814 Medium parameters used: $f = 5800$ MHz; $\sigma = 5.415$ mho/m; $\epsilon_r = 35.658$; $\rho = 1000$ kg/m³

Ambient Temperature : 21.7 °C ; Liquid Temperature : 20.2 °C

DASY5 Configuration:

- Probe: EX3DV4 - SN3590; ConvF(4.79, 4.79, 4.79); Calibrated: 2012/02/23;
- Sensor-Surface: 2mm (Mechanical Surface Detection)
- Electronics: DAE3 Sn579; Calibrated: 2012/04/27
- Phantom: SAM with CRP v5.0 Front; Type: QD000P40CD; Serial: TP:1653
- Measurement SW: DASY52, Version 52.8 (2); SEMCAD X Version 14.6.6 (6824)

Pin=100mW, f=5800 MHz/Area Scan (91x91x1): Measurement grid: dx=10mm, dy=10mm
Maximum value of SAR (interpolated) = 16.4 W/kg

Pin=100mW, f=5800 MHz/Zoom Scan (7x7x9)/Cube 0: Measurement grid: dx=4mm, dy=4mm, dz=2.5mm

Reference Value = 60.304 V/m; Power Drift = -0.02 dB

Peak SAR (extrapolated) = 35.281 mW/g

SAR(1 g) = 7.68 mW/g; SAR(10 g) = 2.14 mW/g

Maximum value of SAR (measured) = 17.0 W/kg

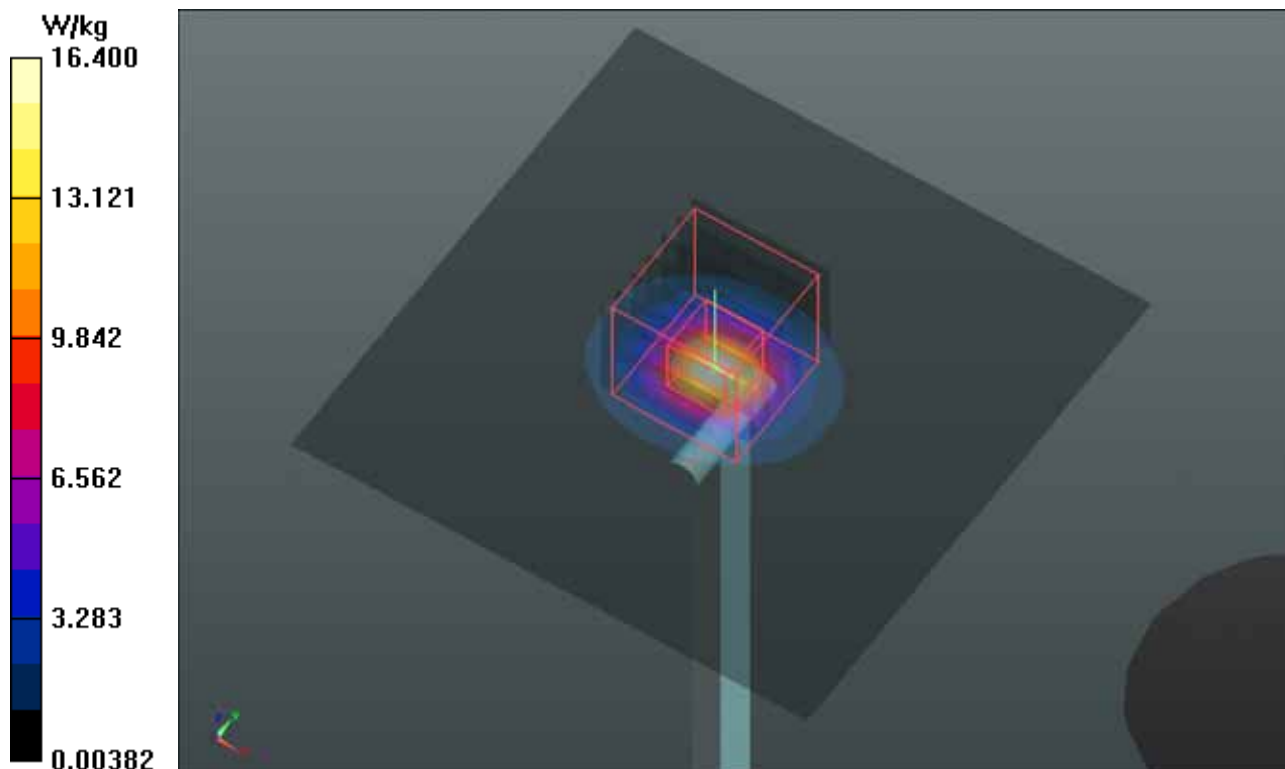

System Check_B2450_120815

DUT: Dipole 2450 MHz; Type: D2450V2; SN: 737

Communication System: CW; Frequency: 2450 MHz; Duty Cycle: 1:1

Medium: B2450_0815 Medium parameters used: $f = 2450$ MHz; $\sigma = 2.01$ mho/m; $\epsilon_r = 52.8$; $\rho = 1000$ kg/m³

Ambient Temperature : 21.6 °C ; Liquid Temperature : 20.5 °C

DASY4 Configuration:

- Probe: EX3DV4 - SN3650; ConvF(6.89, 6.89, 6.89); Calibrated: 2011/10/26
- Sensor-Surface: 2mm (Mechanical Surface Detection)
- Electronics: DAE4 Sn1277; Calibrated: 2012/07/19
- Phantom: SAM Phantom_Front; Type: SAM V4.0; Serial: TP 1654
- Measurement SW: DASY4, V4.7 Build 80; Postprocessing SW: SEMCAD, V1.8 Build 186

Pin=250mW/Area Scan (61x61x1): Measurement grid: dx=15mm, dy=15mm

Maximum value of SAR (interpolated) = 19.5 mW/g

Pin=250mW/Zoom Scan (5x5x7)/Cube 0: Measurement grid: dx=8mm, dy=8mm, dz=5mm

Reference Value = 98.9 V/m; Power Drift = -0.003 dB

Peak SAR (extrapolated) = 26.3 W/kg

SAR(1 g) = 12.7 mW/g; SAR(10 g) = 5.85 mW/g

Maximum value of SAR (measured) = 18.8 mW/g

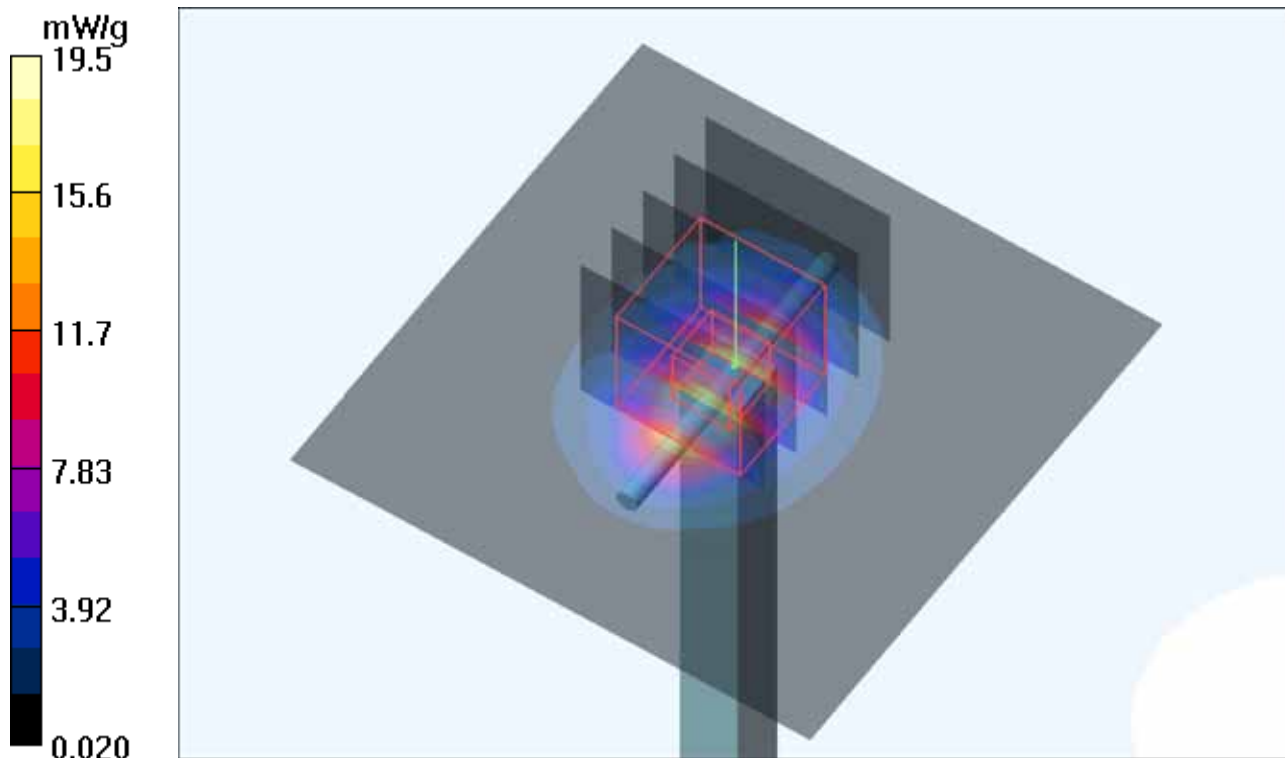

System Check_B2450_120823

DUT: Dipole 2450 MHz; Type: D2450V2; SN: 737

Communication System: CW; Frequency: 2450 MHz; Duty Cycle: 1:1

Medium: B2450_0822 Medium parameters used: $f = 2450$ MHz; $\sigma = 1.971$ mho/m; $\epsilon_r = 51.743$; $\rho = 1000$ kg/m³

Ambient Temperature : 21.6 °C ; Liquid Temperature : 20.5 °C

DASY5 Configuration:

- Probe: EX3DV4 - SN3864; ConvF(7.49, 7.49, 7.49); Calibrated: 2012/07/19;
- Sensor-Surface: 2mm (Mechanical Surface Detection)
- Electronics: DAE4 Sn1277; Calibrated: 2012/07/19
- Phantom: SAM with CRP v5.0 Front; Type: QD000P40CD; Serial: TP:1653
- Measurement SW: DASY52, Version 52.8 (2); SEMCAD X Version 14.6.6 (6824)

Pin=250mW/Area Scan (61x61x1): Measurement grid: dx=15mm, dy=15mm

Maximum value of SAR (interpolated) = 19.3 W/kg

Pin=250mW/Zoom Scan (5x5x7)/Cube 0: Measurement grid: dx=8mm, dy=8mm, dz=5mm

Reference Value = 98.250 V/m; Power Drift = -0.02 dB

Peak SAR (extrapolated) = 25.474 mW/g

SAR(1 g) = 12.2 mW/g; SAR(10 g) = 5.62 mW/g

Maximum value of SAR (measured) = 18.3 W/kg

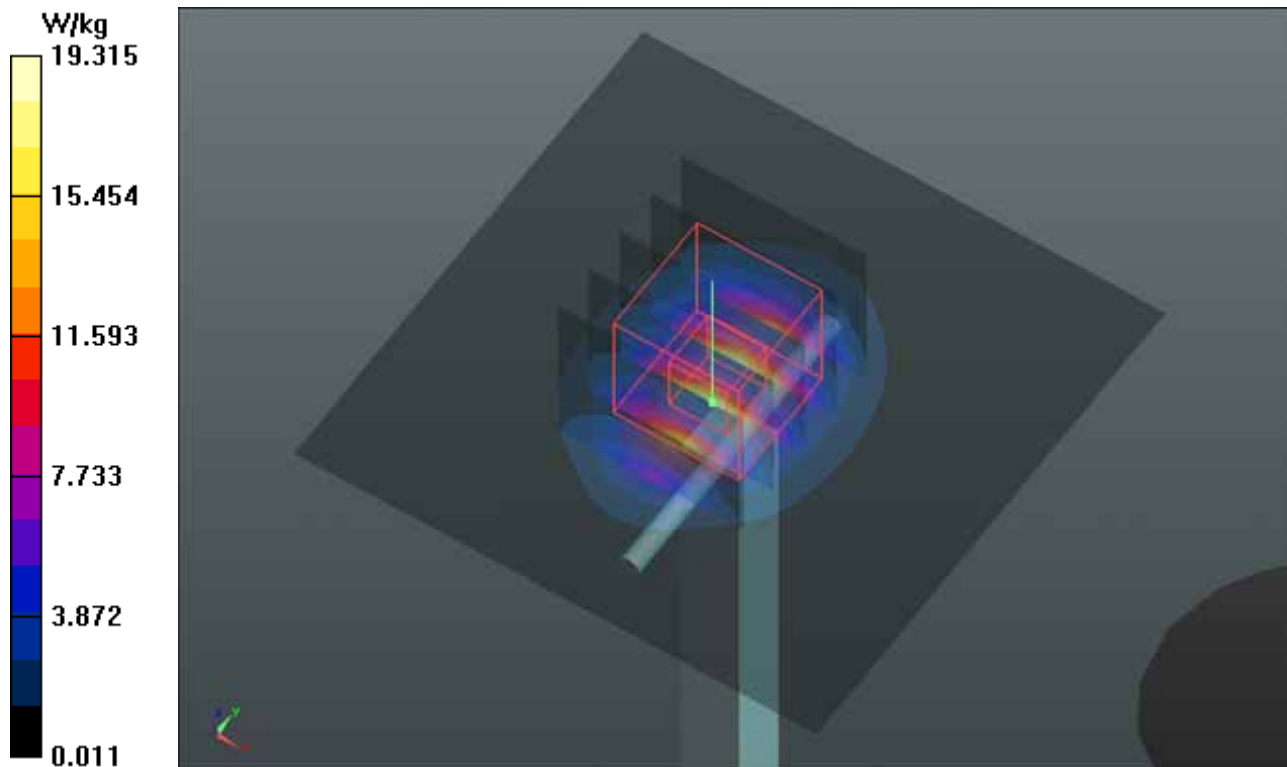

System Check_B5200_120815

DUT: Dipole 5 GHz; Type: D5GHzV2; SN: 1018

Communication System: 802.11a; Frequency: 5200 MHz; Duty Cycle: 1:1

Medium: B5G_0815 Medium parameters used: $f = 5200$ MHz; $\sigma = 5.28$ mho/m; $\epsilon_r = 49.2$; $\rho = 1000$ kg/m³

Ambient Temperature : 21.5 °C ; Liquid Temperature : 20.2 °C

DASY4 Configuration:

- Probe: EX3DV4 - SN3650; ConvF(4.28, 4.28, 4.28); Calibrated: 2011/10/26
- Sensor-Surface: 2mm (Mechanical Surface Detection)
- Electronics: DAE4 Sn1277; Calibrated: 2012/07/19
- Phantom: SAM Phantom_Left; Type: SAM V4.0; Serial: TP 1652
- Measurement SW: DASY4, V4.7 Build 80; Postprocessing SW: SEMCAD, V1.8 Build 186

Pin=100mW, f=5200 MHz/Area Scan (91x91x1): Measurement grid: dx=10mm, dy=10mm
Maximum value of SAR (interpolated) = 15.6 mW/g

Pin=100mW, f=5200 MHz/Zoom Scan (7x7x9)/Cube 0: Measurement grid: dx=4mm, dy=4mm, dz=2.5mm

Reference Value = 58.6 V/m; Power Drift = 0.049 dB

Peak SAR (extrapolated) = 28.0 W/kg

SAR(1 g) = 7.26 mW/g; SAR(10 g) = 2.05 mW/g

Maximum value of SAR (measured) = 15.4 mW/g

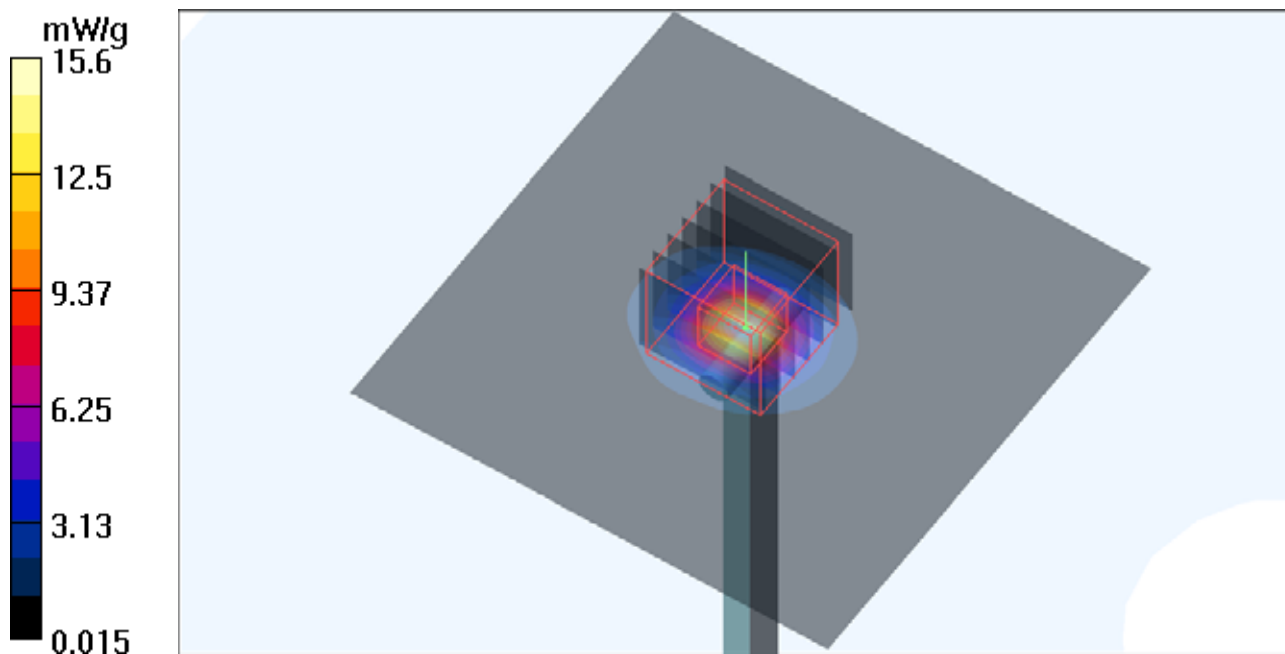

System Check_B5200_120821

DUT: Dipole 5 GHz; Type: D5GHzV2; SN: 1018

Communication System: CW; Frequency: 5200 MHz; Duty Cycle: 1:1

Medium: B5G_0821 Medium parameters used: $f = 5200$ MHz; $\sigma = 5.237$ mho/m; $\epsilon_r = 51.076$; $\rho = 1000$ kg/m³

Ambient Temperature : 21.6 °C ; Liquid Temperature : 20.6 °C

DASY5 Configuration:

- Probe: EX3DV4 - SN3650; ConvF(4.28, 4.28, 4.28); Calibrated: 2011/10/26;
- Sensor-Surface: 2mm (Mechanical Surface Detection)
- Electronics: DAE4 Sn910; Calibrated: 2011/12/07
- Phantom: SAM Phantom_Front; Type: SAM V4.0; Serial: TP 1654
- Measurement SW: DASY52, Version 52.8 (2); SEMCAD X Version 14.6.6 (6824)

Pin=100mW, f=5200 MHz/Area Scan (91x91x1): Measurement grid: dx=10mm, dy=10mm
Maximum value of SAR (interpolated) = 15.6 W/kg

Pin=100mW, f=5200 MHz/Zoom Scan (7x7x9)/Cube 0: Measurement grid: dx=4mm, dy=4mm, dz=2.5mm

Reference Value = 60.298 V/m; Power Drift = 0.04 dB

Peak SAR (extrapolated) = 29.113 mW/g

SAR(1 g) = 7.52 mW/g; SAR(10 g) = 2.11 mW/g

Maximum value of SAR (measured) = 15.9 W/kg

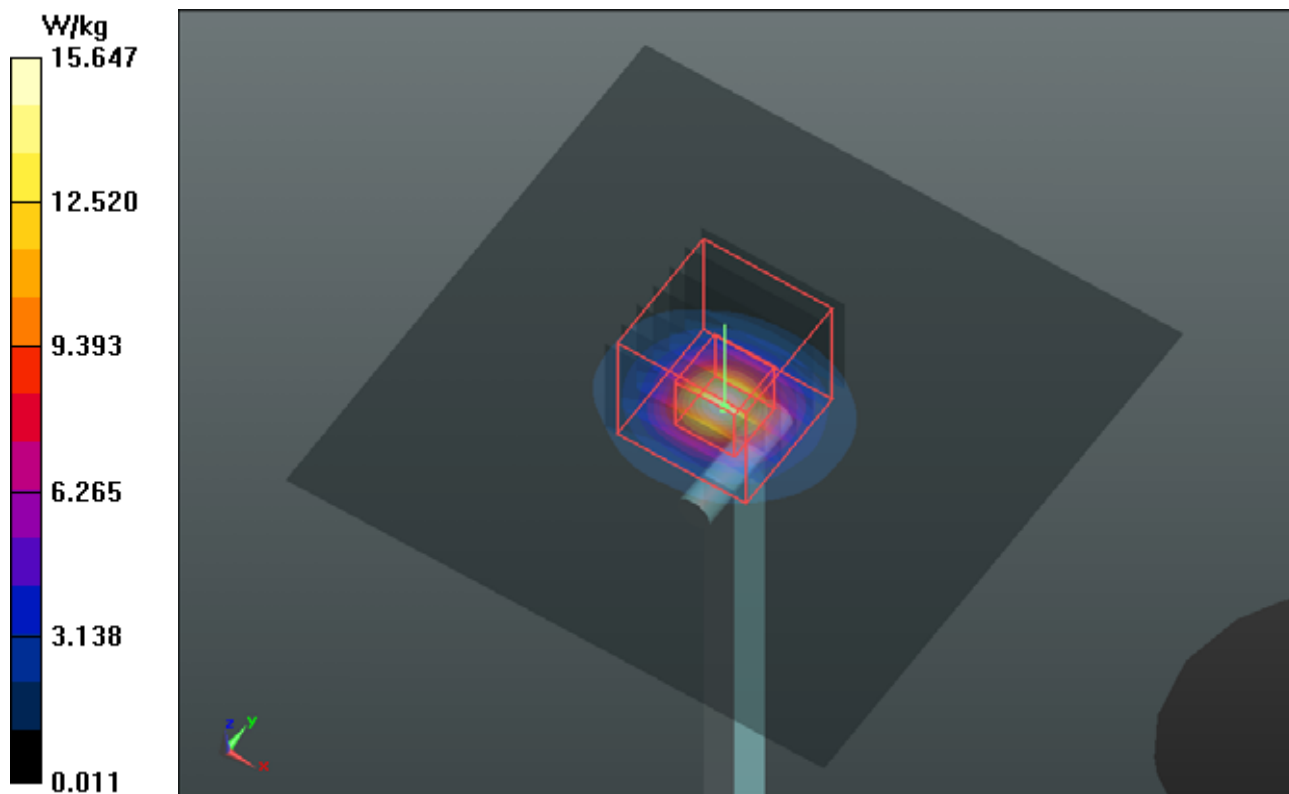

System Check_B5200_120823

DUT: Dipole 5 GHz; Type: D5GHzV2; SN: 1018

Communication System: CW; Frequency: 5200 MHz; Duty Cycle: 1:1

Medium: B5G_0823 Medium parameters used: $f = 5200$ MHz; $\sigma = 5.266$ mho/m; $\epsilon_r = 49.215$; $\rho = 1000$ kg/m³

Ambient Temperature : 21.7 °C ; Liquid Temperature : 20.6 °C

DASY5 Configuration:

- Probe: EX3DV4 - SN3590; ConvF(4.89, 4.89, 4.89); Calibrated: 2012/02/23;
- Sensor-Surface: 2mm (Mechanical Surface Detection)
- Electronics: DAE3 Sn579; Calibrated: 2012/04/27
- Phantom: SAM with CRP v5.0 Front; Type: QD000P40CD; Serial: TP:1653
- Measurement SW: DASY52, Version 52.8 (2); SEMCAD X Version 14.6.6 (6824)

Pin=100mW/Area Scan (91x91x1): Measurement grid: dx=10mm, dy=10mm

Maximum value of SAR (interpolated) = 15.4 W/kg

Pin=100mW/Zoom Scan (7x7x9)/Cube 0: Measurement grid: dx=4mm, dy=4mm, dz=2.5mm

Reference Value = 60.233 V/m; Power Drift = 0.03 dB

Peak SAR (extrapolated) = 28.207 mW/g

SAR(1 g) = 7.48 mW/g; SAR(10 g) = 2.09 mW/g

Maximum value of SAR (measured) = 15.8 W/kg

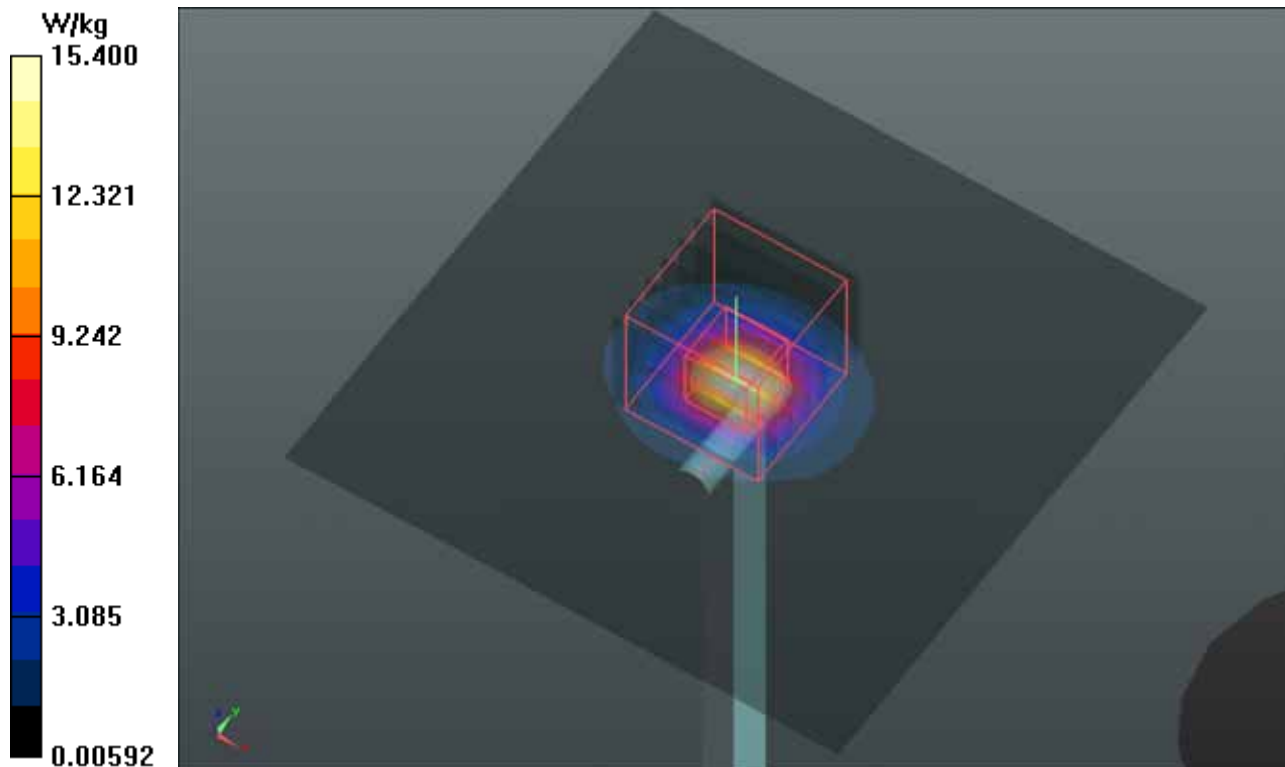

System Check_B5500_120824

DUT: Dipole 5 GHz; Type: D5GHzV2; SN: 1018

Communication System: CW; Frequency: 5500 MHz; Duty Cycle: 1:1

Medium: B5G_0824 Medium parameters used: $f = 5500$ MHz; $\sigma = 5.706$ mho/m; $\epsilon_r = 48.521$; $\rho = 1000$ kg/m³

Ambient Temperature : 21.5 °C ; Liquid Temperature : 20.4 °C

DASY5 Configuration:

- Probe: EX3DV4 - SN3590; ConvF(4.35, 4.35, 4.35); Calibrated: 2012/02/23;
- Sensor-Surface: 2mm (Mechanical Surface Detection)
- Electronics: DAE3 Sn579; Calibrated: 2012/04/27
- Phantom: SAM with CRP v5.0 Front; Type: QD000P40CD; Serial: TP:1653
- Measurement SW: DASY52, Version 52.8 (2); SEMCAD X Version 14.6.6 (6824)

Pin=100mW/Area Scan (91x91x1): Measurement grid: dx=10mm, dy=10mm

Maximum value of SAR (interpolated) = 16.0 W/kg

Pin=100mW/Zoom Scan (7x7x9)/Cube 0: Measurement grid: dx=4mm, dy=4mm, dz=2.5mm

Reference Value = 58.065 V/m; Power Drift = -0.01 dB

Peak SAR (extrapolated) = 31.167 mW/g

SAR(1 g) = 7.69 mW/g; SAR(10 g) = 2.06 mW/g

Maximum value of SAR (measured) = 16.1 W/kg

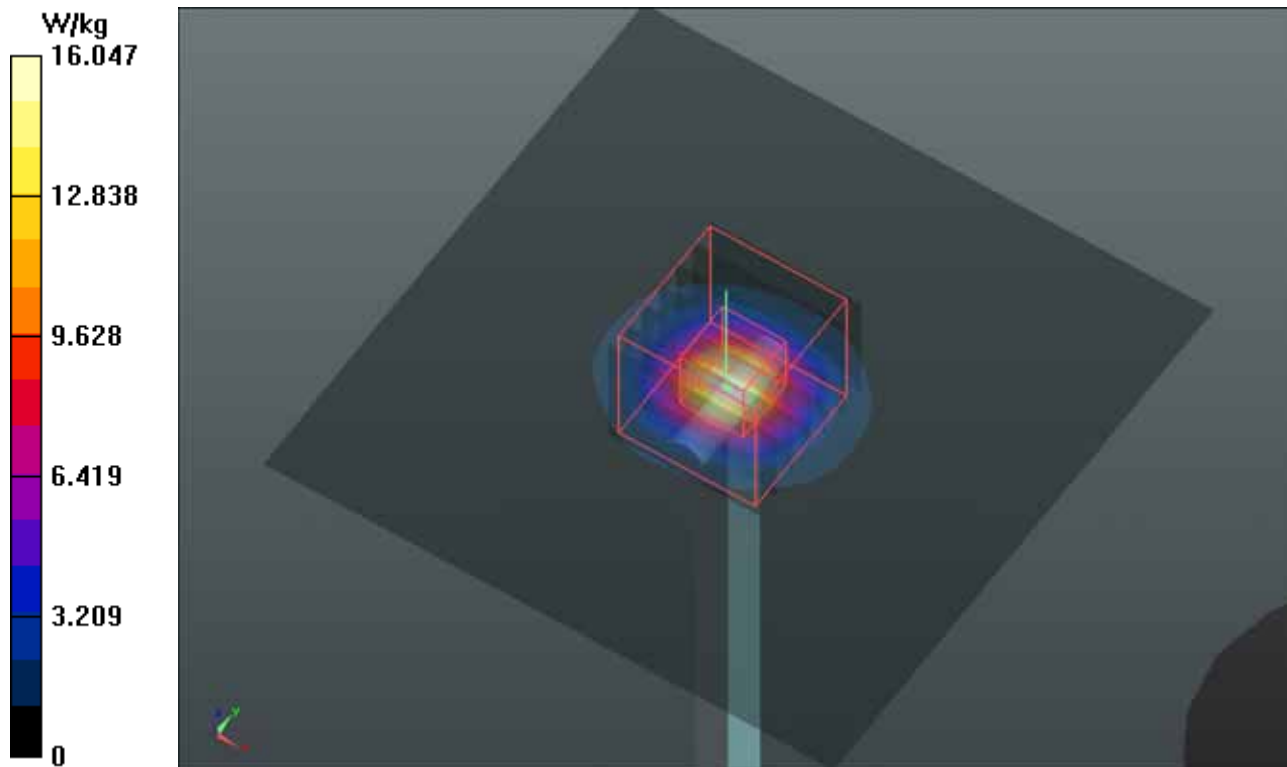

System Check_B5800_120824

DUT: Dipole 5 GHz; Type: D5GHzV2; SN: 1018

Communication System: CW; Frequency: 5800 MHz; Duty Cycle: 1:1

Medium: B5G_0824 Medium parameters used: $f = 5800$ MHz; $\sigma = 6.118$ mho/m; $\epsilon_r = 47.772$; $\rho = 1000$ kg/m³

Ambient Temperature : 21.5 °C ; Liquid Temperature : 20.4 °C

DASY5 Configuration:

- Probe: EX3DV4 - SN3590; ConvF(4.54, 4.54, 4.54); Calibrated: 2012/02/23;
- Sensor-Surface: 2mm (Mechanical Surface Detection)
- Electronics: DAE3 Sn579; Calibrated: 2012/04/27
- Phantom: SAM with CRP v5.0 Front; Type: QD000P40CD; Serial: TP:1653
- Measurement SW: DASY52, Version 52.8 (2); SEMCAD X Version 14.6.6 (6824)

Pin=100mW/Area Scan (91x91x1): Measurement grid: dx=10mm, dy=10mm

Maximum value of SAR (interpolated) = 16.6 W/kg

Pin=100mW/Zoom Scan (7x7x9)/Cube 0: Measurement grid: dx=4mm, dy=4mm, dz=2.5mm

Reference Value = 57.558 V/m; Power Drift = -0.07 dB

Peak SAR (extrapolated) = 33.701 mW/g

SAR(1 g) = 7.7 mW/g; SAR(10 g) = 2.14 mW/g

Maximum value of SAR (measured) = 16.5 W/kg

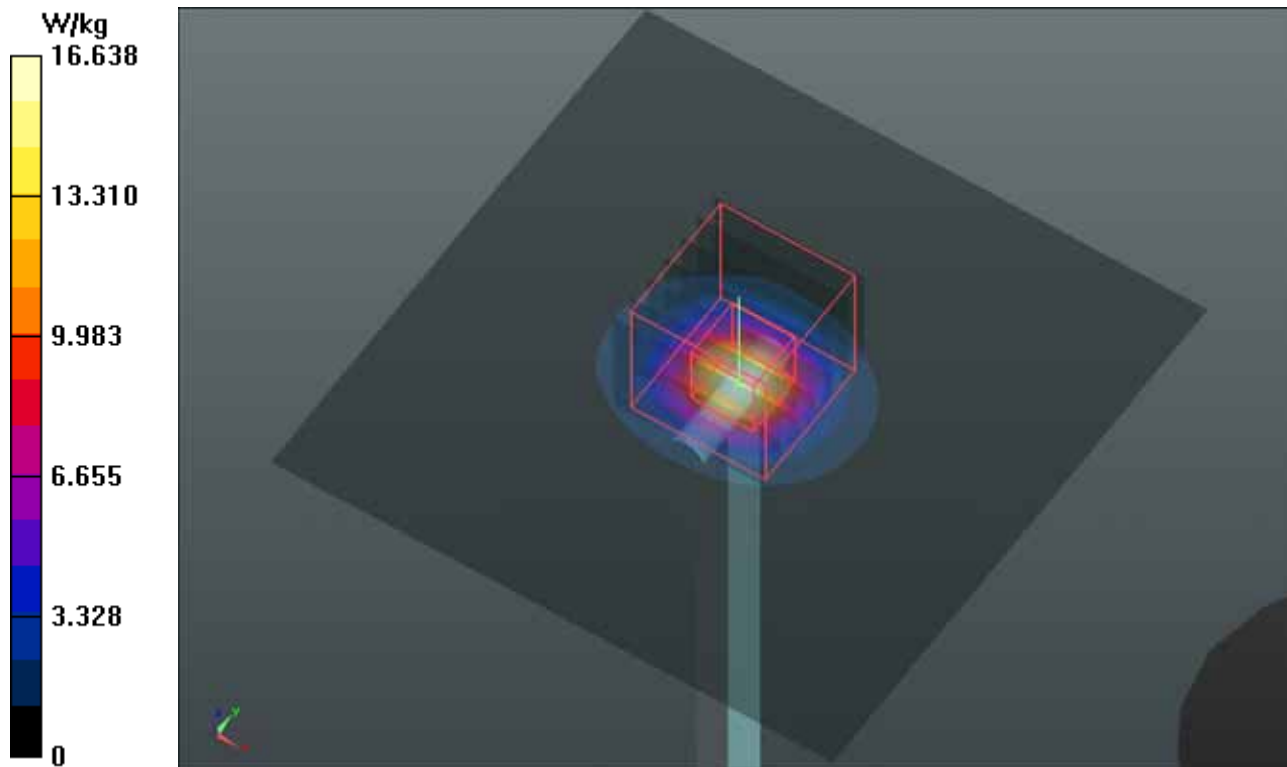



Appendix B. SAR Plots of SAR Measurement

The plots for SAR measurement are shown as follows.

P01 802.11b_Right Cheek_Ch01_w_o MSR_ANT 0_w_o Holster

DUT: 120703C13

Communication System: 802.11b; Frequency: 2412 MHz; Duty Cycle: 1:1

Medium: H2450_0816 Medium parameters used: $f = 2412$ MHz; $\sigma = 1.74$ mho/m; $\epsilon_r = 40.3$; $\rho = 1000$ kg/m³

Ambient Temperature : 21.6 °C ; Liquid Temperature : 20.5 °C

DASY4 Configuration:

- Probe: EX3DV4 - SN3650; ConvF(6.8, 6.8, 6.8); Calibrated: 2011/10/26
- Sensor-Surface: 2mm (Mechanical Surface Detection)
- Electronics: DAE4 Sn1277; Calibrated: 2012/07/19
- Phantom: SAM Phantom_Left; Type: SAM V4.0; Serial: TP 1652
- Measurement SW: DASY4, V4.7 Build 80; Postprocessing SW: SEMCAD, V1.8 Build 186

Ch01/Area Scan (61x101x1): Measurement grid: dx=20mm, dy=20mm

Maximum value of SAR (interpolated) = 0.269 mW/g

Ch01/Zoom Scan (5x5x7)/Cube 0: Measurement grid: dx=8mm, dy=8mm, dz=5mm

Reference Value = 9.02 V/m; Power Drift = 0.164 dB

Peak SAR (extrapolated) = 0.333 W/kg

SAR(1 g) = 0.189 mW/g; SAR(10 g) = 0.101 mW/g

Maximum value of SAR (measured) = 0.264 mW/g

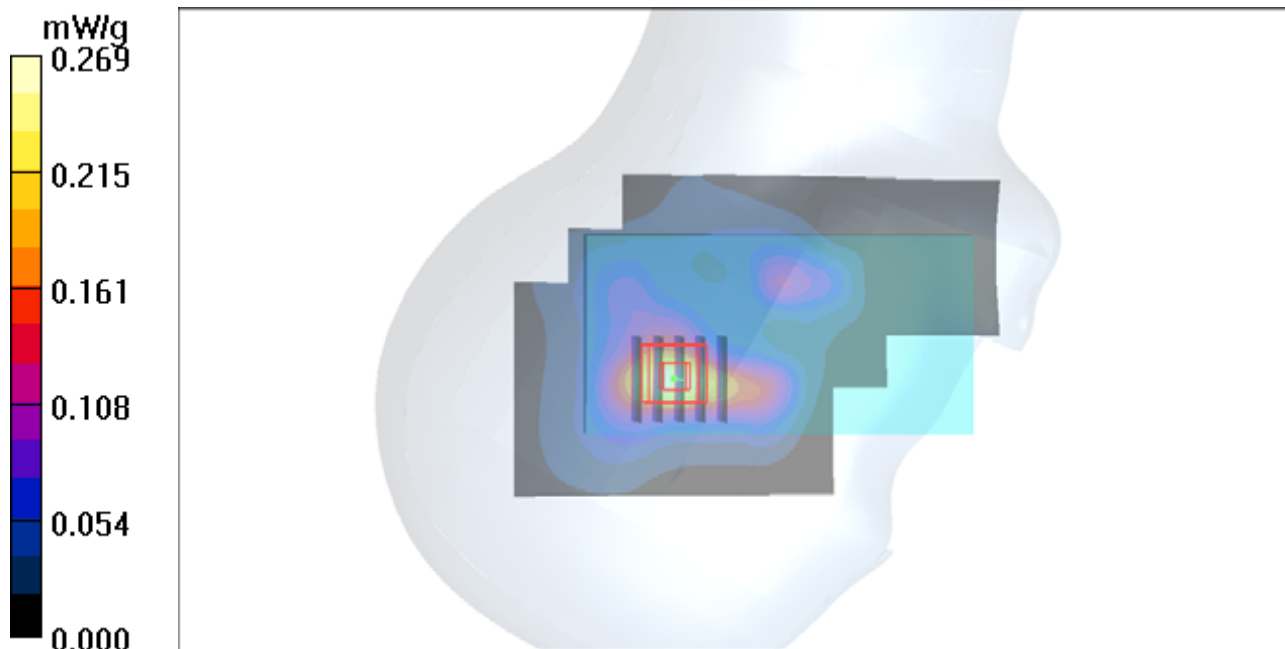

P02 802.11b_Right Cheek_Ch01_w MSR_ANT 0_w_o Holster

DUT: 120703C13

Communication System: 802.11b; Frequency: 2412 MHz; Duty Cycle: 1:1

Medium: H2450_0816 Medium parameters used: $f = 2412$ MHz; $\sigma = 1.74$ mho/m; $\epsilon_r = 40.3$; $\rho = 1000$ kg/m³

Ambient Temperature : 21.6 °C ; Liquid Temperature : 20.5 °C

DASY4 Configuration:

- Probe: EX3DV4 - SN3650; ConvF(6.8, 6.8, 6.8); Calibrated: 2011/10/26
- Sensor-Surface: 2mm (Mechanical Surface Detection)
- Electronics: DAE4 Sn1277; Calibrated: 2012/07/19
- Phantom: SAM Phantom_Left; Type: SAM V4.0; Serial: TP 1652
- Measurement SW: DASY4, V4.7 Build 80; Postprocessing SW: SEMCAD, V1.8 Build 186

Ch01/Area Scan (61x101x1): Measurement grid: dx=20mm, dy=20mm

Maximum value of SAR (interpolated) = 0.104 mW/g

Ch01/Zoom Scan (5x5x7)/Cube 0: Measurement grid: dx=8mm, dy=8mm, dz=5mm

Reference Value = 6.39 V/m; Power Drift = 0.029 dB

Peak SAR (extrapolated) = 0.127 W/kg

SAR(1 g) = 0.068 mW/g; SAR(10 g) = 0.035 mW/g

Maximum value of SAR (measured) = 0.097 mW/g

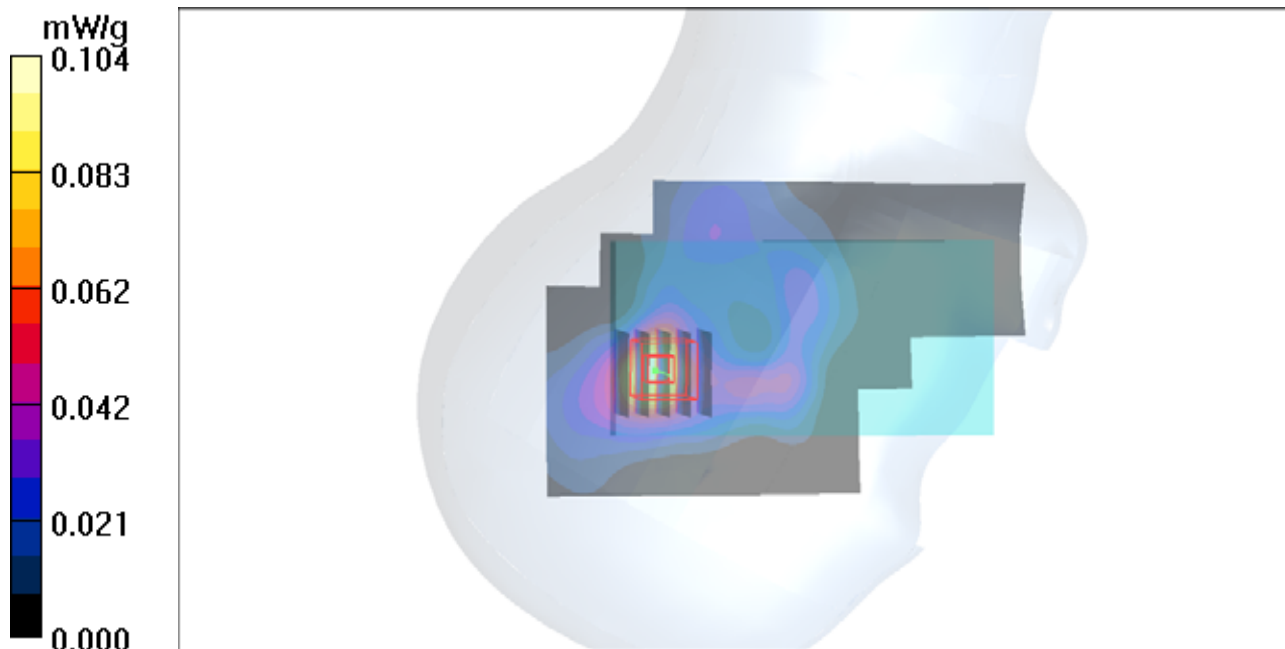

P03 802.11b_Right Tilted_Ch01_w_o MSR_ANT 0_w_o Holster

DUT: 120703C13

Communication System: 802.11b; Frequency: 2412 MHz; Duty Cycle: 1:1

Medium: H2450_0816 Medium parameters used: $f = 2412$ MHz; $\sigma = 1.74$ mho/m; $\epsilon_r = 40.3$; $\rho = 1000$ kg/m³

Ambient Temperature : 21.6 °C ; Liquid Temperature : 20.5 °C

DASY4 Configuration:

- Probe: EX3DV4 - SN3650; ConvF(6.8, 6.8, 6.8); Calibrated: 2011/10/26
- Sensor-Surface: 2mm (Mechanical Surface Detection)
- Electronics: DAE4 Sn1277; Calibrated: 2012/07/19
- Phantom: SAM Phantom_Left; Type: SAM V4.0; Serial: TP 1652
- Measurement SW: DASY4, V4.7 Build 80; Postprocessing SW: SEMCAD, V1.8 Build 186

Ch01/Area Scan (61x101x1): Measurement grid: dx=20mm, dy=20mm

Maximum value of SAR (interpolated) = 0.123 mW/g

Ch01/Zoom Scan (5x5x7)/Cube 0: Measurement grid: dx=8mm, dy=8mm, dz=5mm

Reference Value = 7.93 V/m; Power Drift = 0.069 dB

Peak SAR (extrapolated) = 0.178 W/kg

SAR(1 g) = 0.102 mW/g; SAR(10 g) = 0.054 mW/g

Maximum value of SAR (measured) = 0.138 mW/g

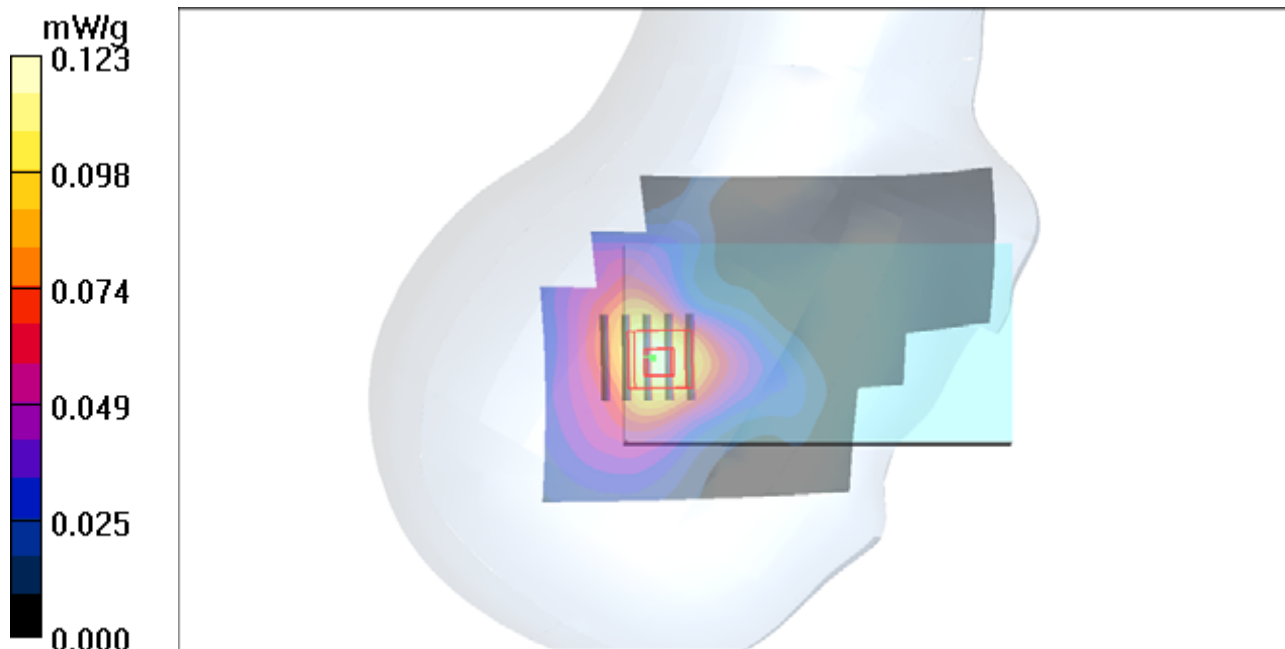

P04 802.11b_Left Cheek_Ch01_w_o MSR_ANT 0_w_o Holster

DUT: 120703C13

Communication System: 802.11b; Frequency: 2412 MHz; Duty Cycle: 1:1

Medium: H2450_0816 Medium parameters used: $f = 2412$ MHz; $\sigma = 1.74$ mho/m; $\epsilon_r = 40.3$; $\rho = 1000$ kg/m³

Ambient Temperature : 21.6 °C ; Liquid Temperature : 20.5 °C

DASY4 Configuration:

- Probe: EX3DV4 - SN3650; ConvF(6.8, 6.8, 6.8); Calibrated: 2011/10/26
- Sensor-Surface: 2mm (Mechanical Surface Detection)
- Electronics: DAE4 Sn1277; Calibrated: 2012/07/19
- Phantom: SAM Phantom_Left; Type: SAM V4.0; Serial: TP 1652
- Measurement SW: DASY4, V4.7 Build 80; Postprocessing SW: SEMCAD, V1.8 Build 186

Ch01/Area Scan (61x101x1): Measurement grid: dx=20mm, dy=20mm

Maximum value of SAR (interpolated) = 0.152 mW/g

Ch01/Zoom Scan (5x5x7)/Cube 1: Measurement grid: dx=8mm, dy=8mm, dz=5mm

Reference Value = 8.47 V/m; Power Drift = -0.124 dB

Peak SAR (extrapolated) = 0.225 W/kg

SAR(1 g) = 0.110 mW/g; SAR(10 g) = 0.055 mW/g

Maximum value of SAR (measured) = 0.168 mW/g

Ch01/Zoom Scan (5x5x7)/Cube 0: Measurement grid: dx=8mm, dy=8mm, dz=5mm

Reference Value = 8.47 V/m; Power Drift = -0.124 dB

Peak SAR (extrapolated) = 0.159 W/kg

SAR(1 g) = 0.094 mW/g; SAR(10 g) = 0.051 mW/g

Maximum value of SAR (measured) = 0.124 mW/g

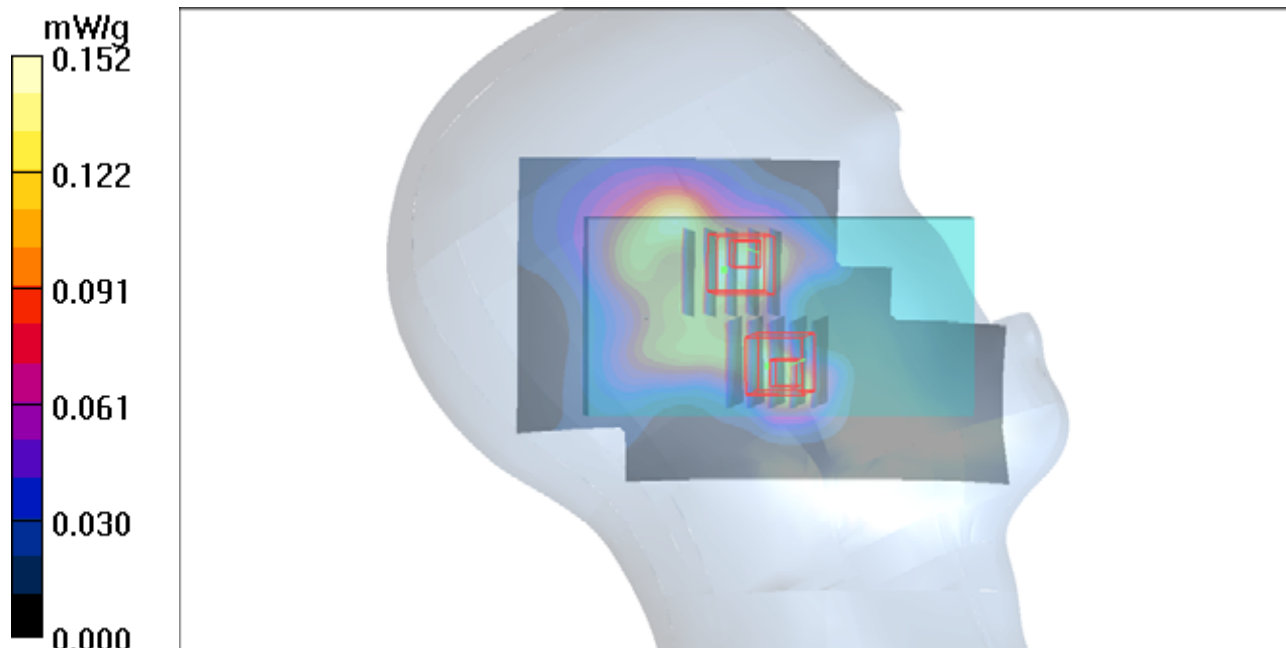

P05 802.11b_Left Tilted_Ch01_w_o MSR_ANT 0_w_o Holster

DUT: 120703C13

Communication System: 802.11b; Frequency: 2412 MHz; Duty Cycle: 1:1

Medium: H2450_0816 Medium parameters used: $f = 2412$ MHz; $\sigma = 1.74$ mho/m; $\epsilon_r = 40.3$; $\rho = 1000$ kg/m³

Ambient Temperature : 21.6 °C ; Liquid Temperature : 20.5 °C

DASY4 Configuration:

- Probe: EX3DV4 - SN3650; ConvF(6.8, 6.8, 6.8); Calibrated: 2011/10/26
- Sensor-Surface: 2mm (Mechanical Surface Detection)
- Electronics: DAE4 Sn1277; Calibrated: 2012/07/19
- Phantom: SAM Phantom_Left; Type: SAM V4.0; Serial: TP 1652
- Measurement SW: DASY4, V4.7 Build 80; Postprocessing SW: SEMCAD, V1.8 Build 186

Ch01/Area Scan (61x101x1): Measurement grid: dx=20mm, dy=20mm

Maximum value of SAR (interpolated) = 0.158 mW/g

Ch01/Zoom Scan (5x5x7)/Cube 0: Measurement grid: dx=8mm, dy=8mm, dz=5mm

Reference Value = 8.66 V/m; Power Drift = -0.005 dB

Peak SAR (extrapolated) = 0.211 W/kg

SAR(1 g) = 0.107 mW/g; SAR(10 g) = 0.056 mW/g

Maximum value of SAR (measured) = 0.158 mW/g

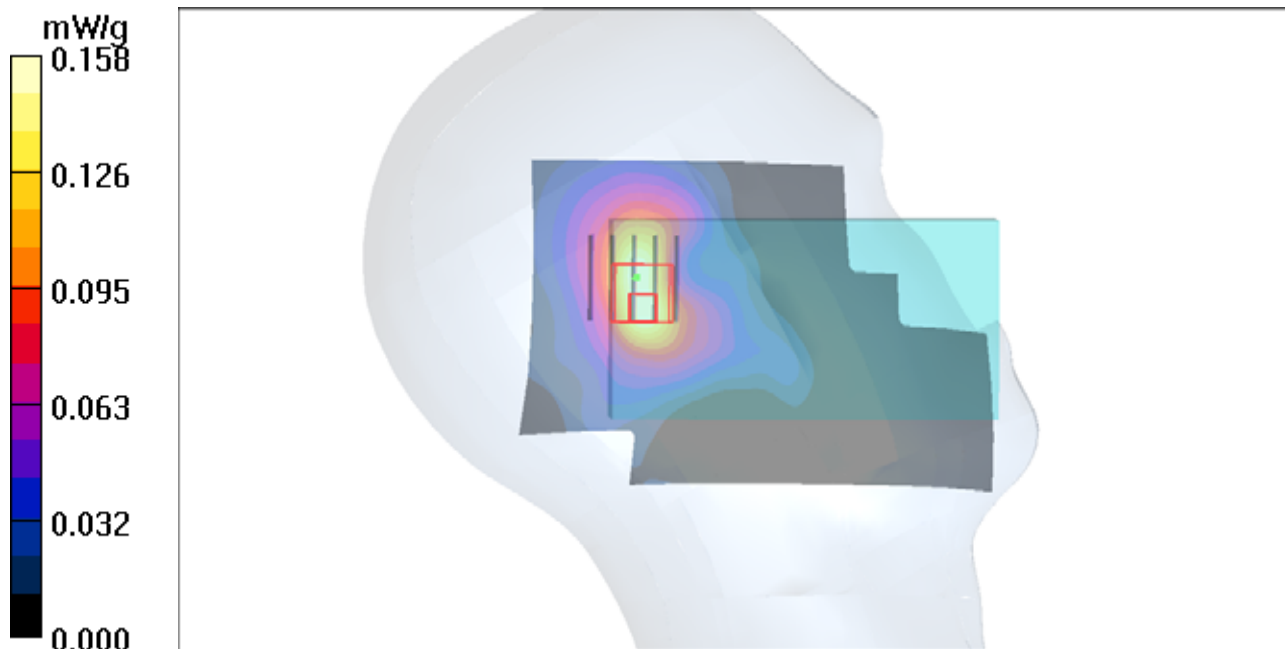

P137 802.11b_Right Cheek_Ch01_w_o MSR_ANT 1_w_o Holster

DUT: 120703C13

Communication System: 802.11b; Frequency: 2412 MHz; Duty Cycle: 1:1

Medium: H2450_0816 Medium parameters used: $f = 2412$ MHz; $\sigma = 1.74$ mho/m; $\epsilon_r = 40.3$; $\rho = 1000$ kg/m³

Ambient Temperature : 21.6 °C ; Liquid Temperature : 20.5 °C

DASY4 Configuration:

- Probe: EX3DV4 - SN3650; ConvF(6.8, 6.8, 6.8); Calibrated: 2011/10/26
- Sensor-Surface: 2mm (Mechanical Surface Detection)
- Electronics: DAE4 Sn1277; Calibrated: 2012/07/19
- Phantom: SAM Phantom_Left; Type: SAM V4.0; Serial: TP 1652
- Measurement SW: DASY4, V4.7 Build 80; Postprocessing SW: SEMCAD, V1.8 Build 186

Ch01/Area Scan (61x101x1): Measurement grid: dx=20mm, dy=20mm

Maximum value of SAR (interpolated) = 0.207 mW/g

Ch01/Zoom Scan (5x5x7)/Cube 0: Measurement grid: dx=8mm, dy=8mm, dz=5mm

Reference Value = 8.57 V/m; Power Drift = 0.181 dB

Peak SAR (extrapolated) = 0.293 W/kg

SAR(1 g) = 0.165 mW/g; SAR(10 g) = 0.086 mW/g

Maximum value of SAR (measured) = 0.225 mW/g

Ch01/Zoom Scan (5x5x7)/Cube 1: Measurement grid: dx=8mm, dy=8mm, dz=5mm

Reference Value = 8.57 V/m; Power Drift = 0.181 dB

Peak SAR (extrapolated) = 0.257 W/kg

SAR(1 g) = 0.123 mW/g; SAR(10 g) = 0.066 mW/g

Maximum value of SAR (measured) = 0.200 mW/g

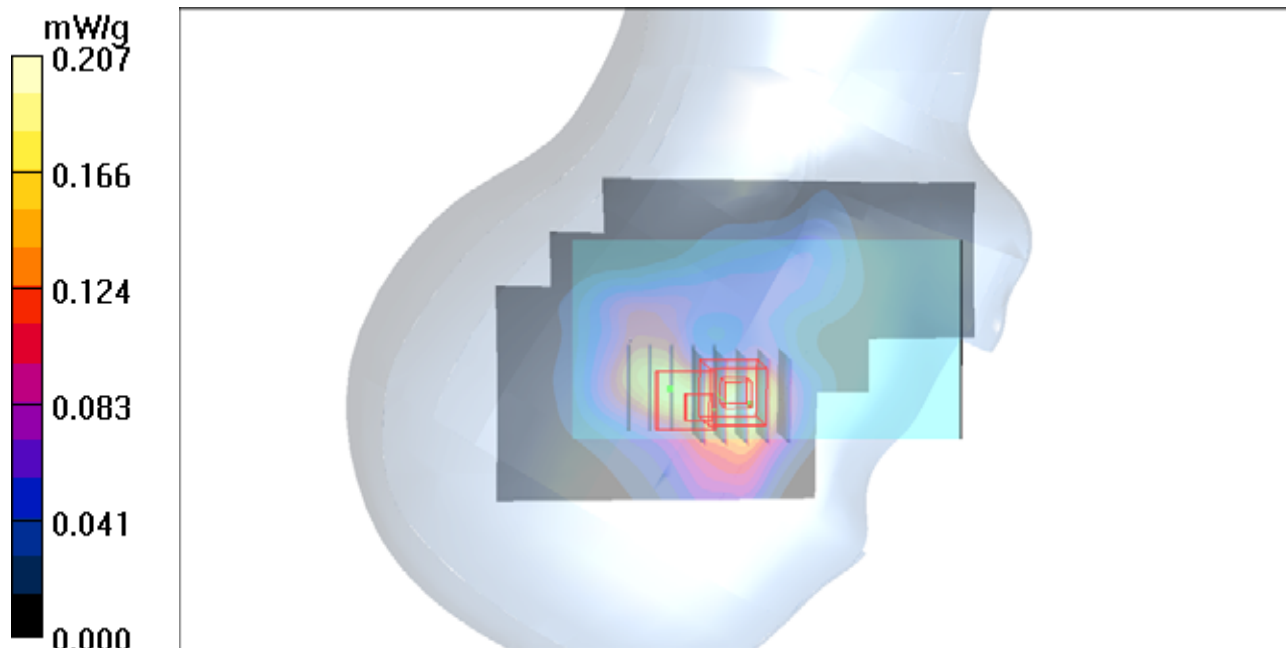

P138 802.11b_Right Cheek_Ch01_w MSR_ANT 1_w_o Holster

DUT: 120703C13

Communication System: 802.11b; Frequency: 2412 MHz; Duty Cycle: 1:1

Medium: H2450_0816 Medium parameters used: $f = 2412$ MHz; $\sigma = 1.74$ mho/m; $\epsilon_r = 40.3$; $\rho = 1000$ kg/m³

Ambient Temperature : 21.6 °C ; Liquid Temperature : 20.5 °C

DASY4 Configuration:

- Probe: EX3DV4 - SN3650; ConvF(6.8, 6.8, 6.8); Calibrated: 2011/10/26
- Sensor-Surface: 2mm (Mechanical Surface Detection)
- Electronics: DAE4 Sn1277; Calibrated: 2012/07/19
- Phantom: SAM Phantom_Left; Type: SAM V4.0; Serial: TP 1652
- Measurement SW: DASY4, V4.7 Build 80; Postprocessing SW: SEMCAD, V1.8 Build 186

Ch01/Area Scan (61x101x1): Measurement grid: dx=20mm, dy=20mm

Maximum value of SAR (interpolated) = 0.313 mW/g

Ch01/Zoom Scan (5x5x7)/Cube 0: Measurement grid: dx=8mm, dy=8mm, dz=5mm

Reference Value = 8.01 V/m; Power Drift = 0.026 dB

Peak SAR (extrapolated) = 0.460 W/kg

SAR(1 g) = 0.257 mW/g; SAR(10 g) = 0.134 mW/g

Maximum value of SAR (measured) = 0.350 mW/g

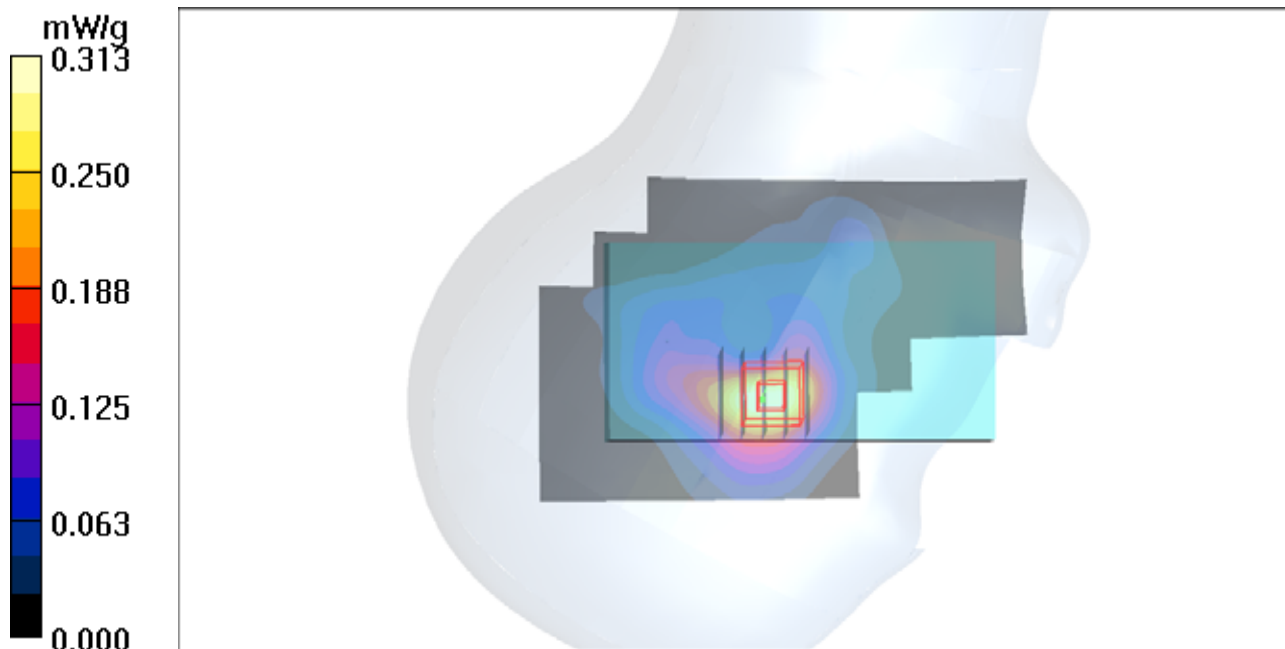

1g/10g Averaged SAR

SAR; Zoom Scan: Value Along Z, X=2, Y=2

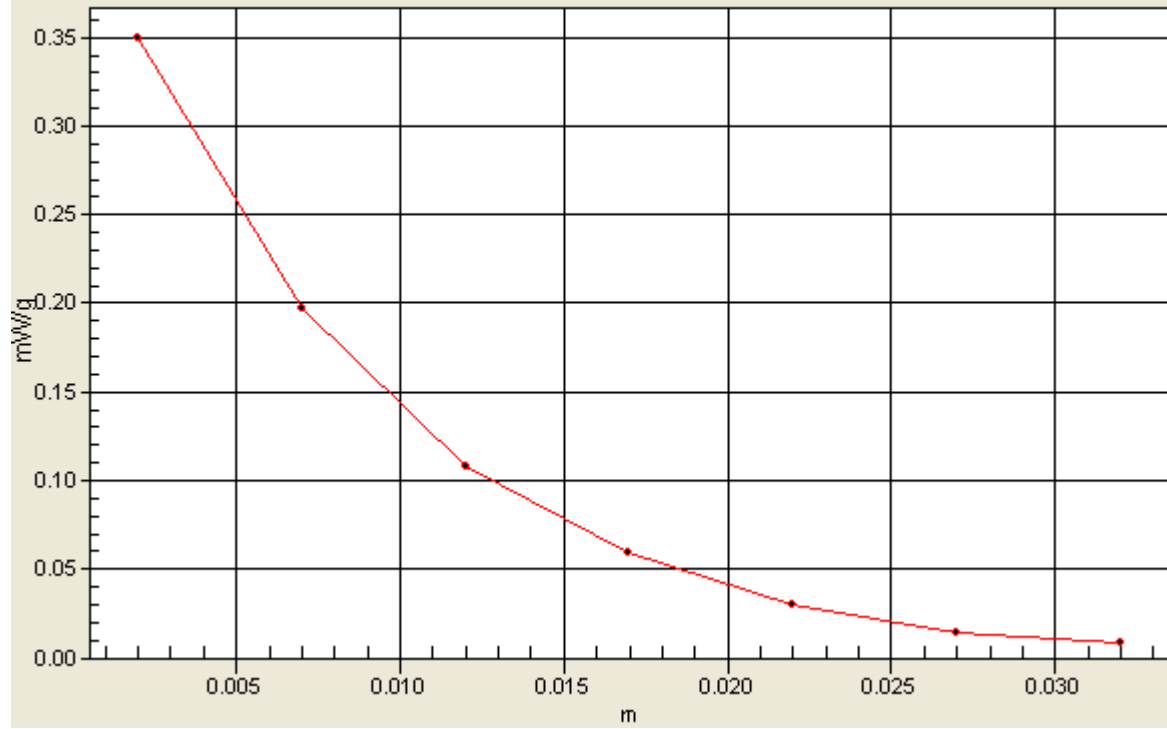

P139 802.11b_Right Tilted_Ch01_w MSR_ANT 1_w_o Holster

DUT: 120703C13

Communication System: 802.11b; Frequency: 2412 MHz; Duty Cycle: 1:1

Medium: H2450_0816 Medium parameters used: $f = 2412$ MHz; $\sigma = 1.74$ mho/m; $\epsilon_r = 40.3$; $\rho = 1000$ kg/m³

Ambient Temperature : 21.6 °C ; Liquid Temperature : 20.5 °C

DASY4 Configuration:

- Probe: EX3DV4 - SN3650; ConvF(6.8, 6.8, 6.8); Calibrated: 2011/10/26
- Sensor-Surface: 2mm (Mechanical Surface Detection)
- Electronics: DAE4 Sn1277; Calibrated: 2012/07/19
- Phantom: SAM Phantom_Left; Type: SAM V4.0; Serial: TP 1652
- Measurement SW: DASY4, V4.7 Build 80; Postprocessing SW: SEMCAD, V1.8 Build 186

Ch01/Area Scan (61x101x1): Measurement grid: dx=20mm, dy=20mm

Maximum value of SAR (interpolated) = 0.169 mW/g

Ch01/Zoom Scan (5x5x7)/Cube 0: Measurement grid: dx=8mm, dy=8mm, dz=5mm

Reference Value = 7.74 V/m; Power Drift = 0.111 dB

Peak SAR (extrapolated) = 0.201 W/kg

SAR(1 g) = 0.111 mW/g; SAR(10 g) = 0.060 mW/g

Maximum value of SAR (measured) = 0.150 mW/g

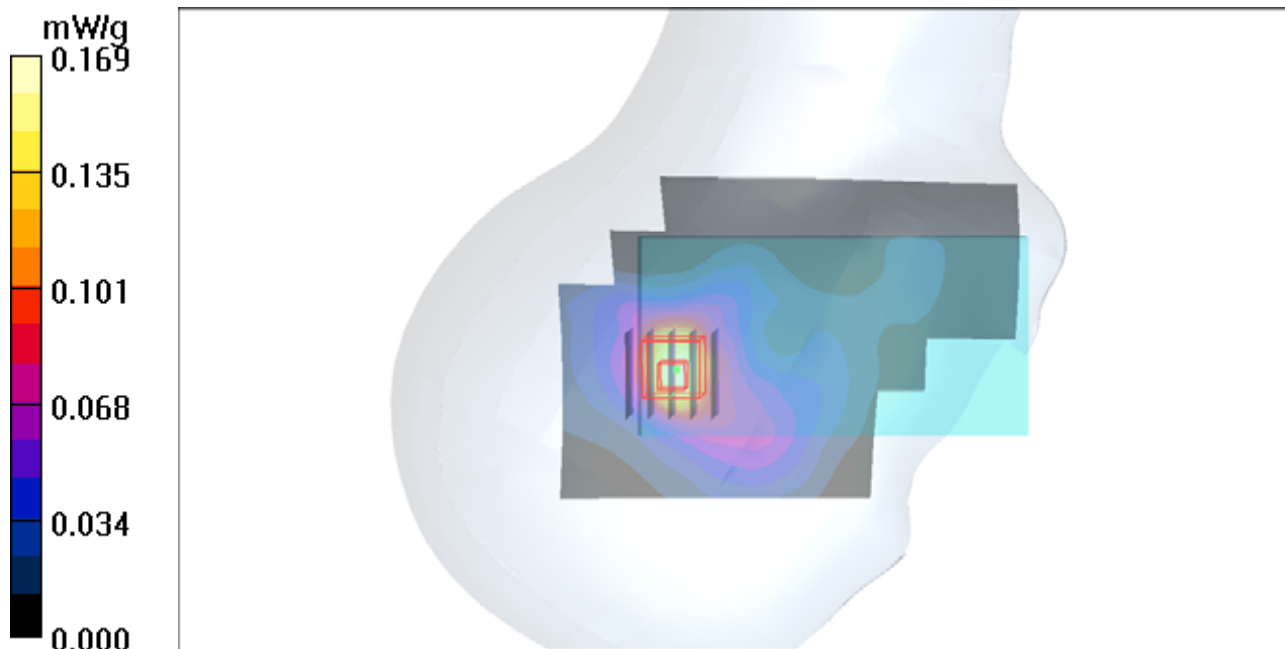

P140 802.11b_Left Cheek_Ch01_w MSR_ANT 1_w_o Holster

DUT: 120703C13

Communication System: 802.11b; Frequency: 2412 MHz; Duty Cycle: 1:1

Medium: H2450_0816 Medium parameters used: $f = 2412$ MHz; $\sigma = 1.74$ mho/m; $\epsilon_r = 40.3$; $\rho = 1000$ kg/m³

Ambient Temperature : 21.6 °C ; Liquid Temperature : 20.5 °C

DASY4 Configuration:

- Probe: EX3DV4 - SN3650; ConvF(6.8, 6.8, 6.8); Calibrated: 2011/10/26
- Sensor-Surface: 2mm (Mechanical Surface Detection)
- Electronics: DAE4 Sn1277; Calibrated: 2012/07/19
- Phantom: SAM Phantom_Left; Type: SAM V4.0; Serial: TP 1652
- Measurement SW: DASY4, V4.7 Build 80; Postprocessing SW: SEMCAD, V1.8 Build 186

Ch01/Area Scan (61x101x1): Measurement grid: dx=20mm, dy=20mm

Maximum value of SAR (interpolated) = 0.247 mW/g

Ch01/Zoom Scan (5x5x7)/Cube 0: Measurement grid: dx=8mm, dy=8mm, dz=5mm

Reference Value = 7.40 V/m; Power Drift = -0.023 dB

Peak SAR (extrapolated) = 0.318 W/kg

SAR(1 g) = 0.182 mW/g; SAR(10 g) = 0.096 mW/g

Maximum value of SAR (measured) = 0.251 mW/g

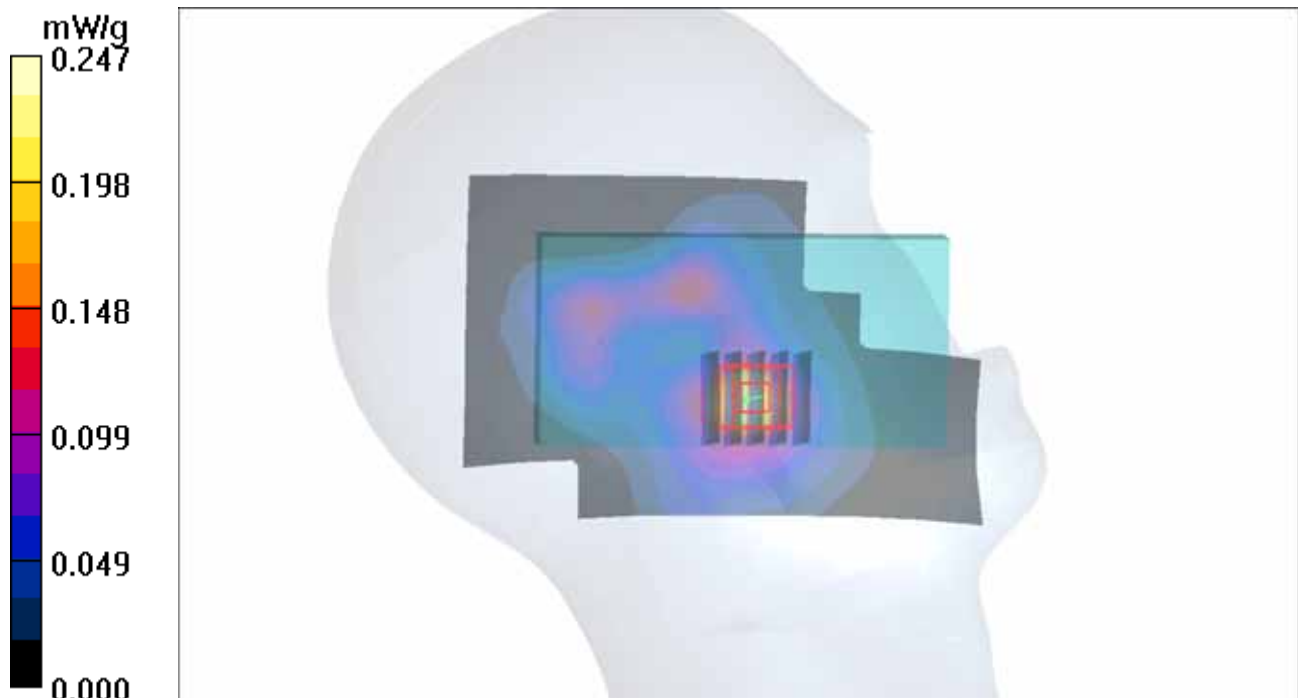

P141 802.11b_Left Tilted_Ch01_w MSR_ANT 1_w_o Holster

DUT: 120703C13

Communication System: 802.11b; Frequency: 2412 MHz; Duty Cycle: 1:1

Medium: H2450_0816 Medium parameters used: $f = 2412$ MHz; $\sigma = 1.74$ mho/m; $\epsilon_r = 40.3$; $\rho = 1000$ kg/m³

Ambient Temperature : 21.6 °C; Liquid Temperature : 20.5 °C

DASY4 Configuration:

- Probe: EX3DV4 - SN3650; ConvF(6.8, 6.8, 6.8); Calibrated: 2011/10/26
- Sensor-Surface: 2mm (Mechanical Surface Detection)
- Electronics: DAE4 Sn1277; Calibrated: 2012/07/19
- Phantom: SAM Phantom_Left; Type: SAM V4.0; Serial: TP 1652
- Measurement SW: DASY4, V4.7 Build 80; Postprocessing SW: SEMCAD, V1.8 Build 186

Ch01/Area Scan (61x101x1): Measurement grid: dx=20mm, dy=20mm

Maximum value of SAR (interpolated) = 0.163 mW/g

Ch01/Zoom Scan (5x5x7)/Cube 0: Measurement grid: dx=8mm, dy=8mm, dz=5mm

Reference Value = 7.51 V/m; Power Drift = -0.023 dB

Peak SAR (extrapolated) = 0.213 W/kg

SAR(1 g) = 0.110 mW/g; SAR(10 g) = 0.055 mW/g

Maximum value of SAR (measured) = 0.161 mW/g

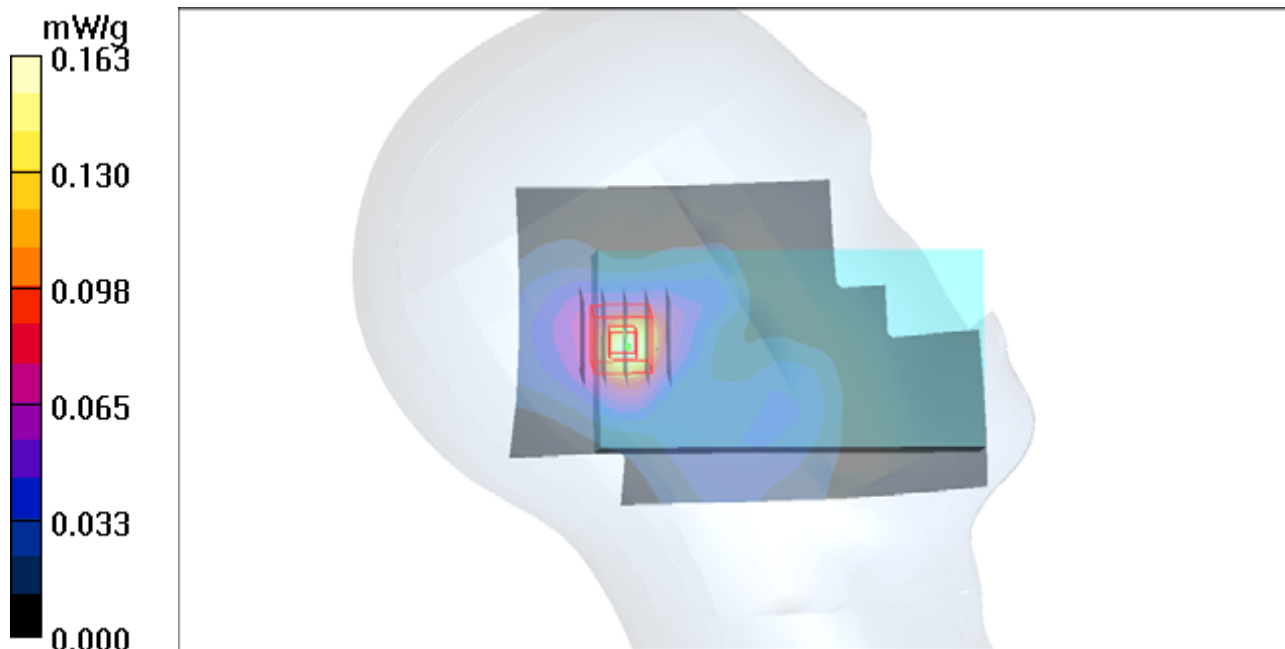

P16 802.11a_Right Cheek_Ch48_w MSR_Ant 0_w_o Holster

DUT: 120703C13

Communication System: WLAN_5G; Frequency: 5240 MHz; Duty Cycle: 1:1

Medium: H5G_0811 Medium parameters used: $f = 5240$ MHz; $\sigma = 4.79$ mho/m; $\epsilon_r = 37.074$; $\rho = 1000$ kg/m³

Ambient Temperature : 21.6 °C ; Liquid Temperature : 20.2 °C

DASY5 Configuration:

- Probe: EX3DV4 - SN3590; ConvF(5.64, 5.64, 5.64); Calibrated: 2012/02/23;
- Sensor-Surface: 2mm (Mechanical Surface Detection)
- Electronics: DAE3 Sn579; Calibrated: 2012/04/27
- Phantom: SAM with CRP v5.0 Front; Type: QD000P40CD; Serial: TP:1653
- Measurement SW: DASY52, Version 52.8 (1); SEMCAD X Version 14.6.5 (6469)

Ch48/Area Scan (161x201x1): Measurement grid: dx=10mm, dy=10mm

Maximum value of SAR (interpolated) = 0.00480 mW/g

Ch48/Zoom Scan (7x7x9)/Cube 0: Measurement grid: dx=4mm, dy=4mm, dz=2.5mm

Reference Value = 0 V/m; Power Drift = 0.00 dB

Peak SAR (extrapolated) = 0.022 mW/g

SAR(1 g) = 0.000225 mW/g; SAR(10 g) = 2.19e-005 mW/g

Maximum value of SAR (measured) = 0.0465 mW/g

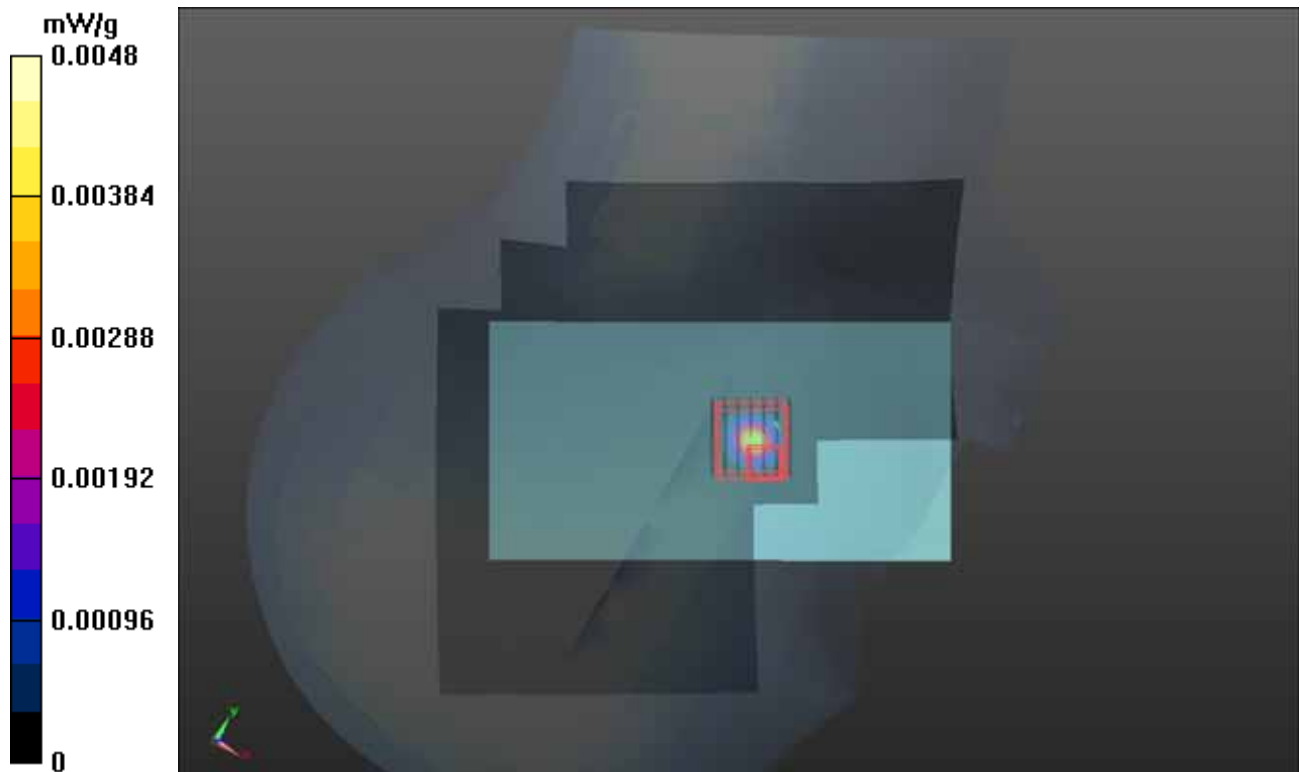

P17 802.11a_Right Tilted_Ch48_w MSR_Ant 0_w_o Holster

DUT: 120703C13

Communication System: WLAN_5G; Frequency: 5240 MHz; Duty Cycle: 1:1

Medium: H5G_0811 Medium parameters used: $f = 5240$ MHz; $\sigma = 4.79$ mho/m; $\epsilon_r = 37.074$; $\rho = 1000$ kg/m³

Ambient Temperature : 21.6 °C ; Liquid Temperature : 20.2 °C

DASY5 Configuration:

- Probe: EX3DV4 - SN3590; ConvF(5.64, 5.64, 5.64); Calibrated: 2012/02/23;
- Sensor-Surface: 2mm (Mechanical Surface Detection)
- Electronics: DAE3 Sn579; Calibrated: 2012/04/27
- Phantom: SAM with CRP v5.0 Front; Type: QD000P40CD; Serial: TP:1653
- Measurement SW: DASY52, Version 52.8 (1); SEMCAD X Version 14.6.5 (6469)

Ch48/Area Scan (161x201x1): Measurement grid: dx=10mm, dy=10mm

Maximum value of SAR (interpolated) = 0.00235 mW/g

Ch48/Zoom Scan (7x7x9)/Cube 0: Measurement grid: dx=4mm, dy=4mm, dz=2.5mm

Reference Value = 0 V/m; Power Drift = 0.00 dB

Peak SAR (extrapolated) = 0.012 mW/g

SAR(1 g) = 0.000117 mW/g; SAR(10 g) = 7.49e-006 mW/g

Maximum value of SAR (measured) = 0.0243 mW/g

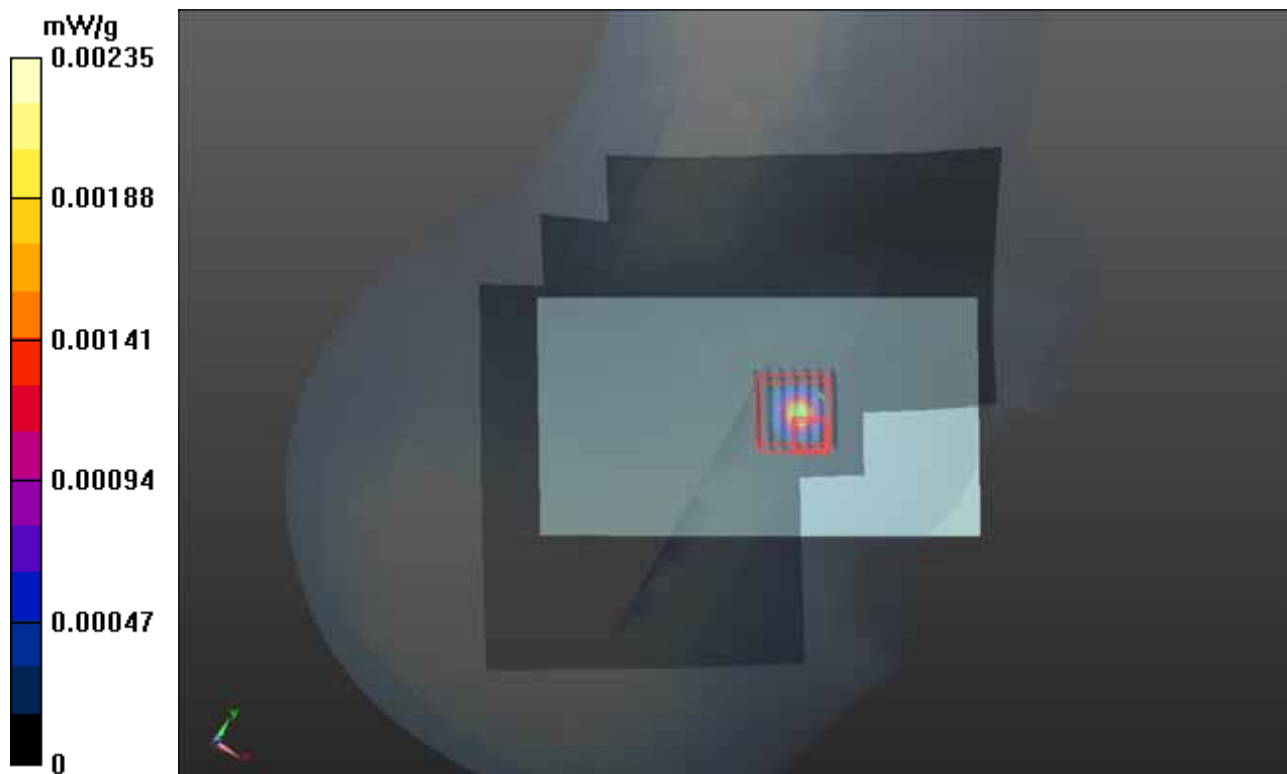

P18 802.11a_Left Cheek_Ch48_w MSR_Ant 0_w_o Holster

DUT: 120703C13

Communication System: WLAN_5G; Frequency: 5240 MHz; Duty Cycle: 1:1

Medium: H5G_0811 Medium parameters used: $f = 5240$ MHz; $\sigma = 4.79$ mho/m; $\epsilon_r = 37.074$; $\rho = 1000$ kg/m³

Ambient Temperature : 21.6 °C ; Liquid Temperature : 20.2 °C

DASY5 Configuration:

- Probe: EX3DV4 - SN3590; ConvF(5.64, 5.64, 5.64); Calibrated: 2012/02/23;
- Sensor-Surface: 2mm (Mechanical Surface Detection)
- Electronics: DAE3 Sn579; Calibrated: 2012/04/27
- Phantom: SAM with CRP v5.0 Front; Type: QD000P40CD; Serial: TP:1653
- Measurement SW: DASY52, Version 52.8 (1); SEMCAD X Version 14.6.5 (6469)

Ch48/Area Scan (141x181x1): Measurement grid: dx=10mm, dy=10mm

Maximum value of SAR (interpolated) = 0.0545 mW/g

Ch48/Zoom Scan (7x7x9)/Cube 0: Measurement grid: dx=4mm, dy=4mm, dz=2.5mm

Reference Value = 0 V/m; Power Drift = 0.00 dB

Peak SAR (extrapolated) = 0.217 mW/g

SAR(1 g) = 0.00564 mW/g; SAR(10 g) = 0.000585 mW/g

Maximum value of SAR (measured) = 0.141 mW/g

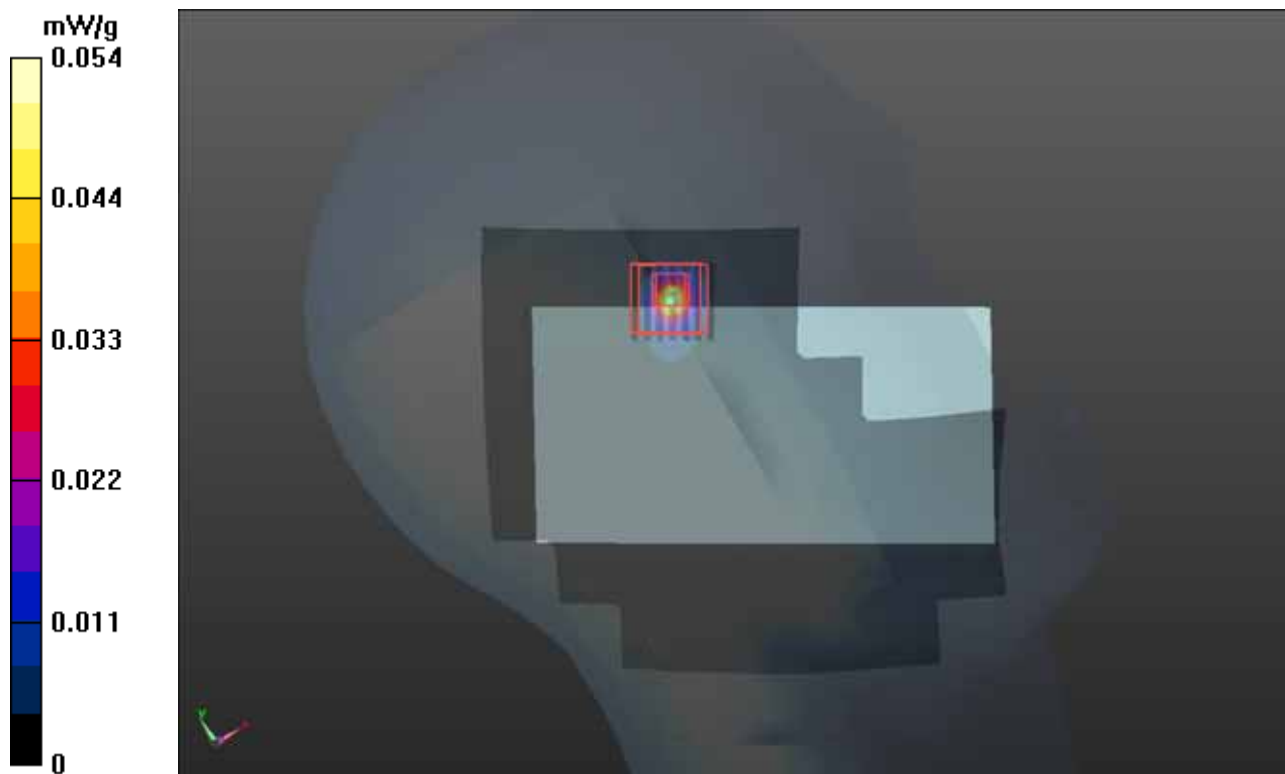

P19 802.11a_Left Tilted_Ch48_w MSR_Ant 0_w_o Holster

DUT: 120703C13

Communication System: WLAN_5G; Frequency: 5240 MHz; Duty Cycle: 1:1

Medium: H5G_0811 Medium parameters used: $f = 5240$ MHz; $\sigma = 4.79$ mho/m; $\epsilon_r = 37.074$; $\rho = 1000$ kg/m³

Ambient Temperature : 21.6 °C ; Liquid Temperature : 20.2 °C

DASY5 Configuration:

- Probe: EX3DV4 - SN3590; ConvF(5.64, 5.64, 5.64); Calibrated: 2012/02/23;
- Sensor-Surface: 2mm (Mechanical Surface Detection)
- Electronics: DAE3 Sn579; Calibrated: 2012/04/27
- Phantom: SAM with CRP v5.0 Front; Type: QD000P40CD; Serial: TP:1653
- Measurement SW: DASY52, Version 52.8 (1); SEMCAD X Version 14.6.5 (6469)

Ch48/Area Scan (141x181x1): Measurement grid: dx=10mm, dy=10mm

Maximum value of SAR (interpolated) = 0.0145 mW/g

Ch48/Zoom Scan (7x7x9)/Cube 1: Measurement grid: dx=4mm, dy=4mm, dz=2.5mm

Reference Value = 0 V/m; Power Drift = 0.19 dB

Peak SAR (extrapolated) = 0.098 mW/g

SAR(1 g) = 0.00288 mW/g; SAR(10 g) = 0.000298 mW/g

Maximum value of SAR (measured) = 0.0521 mW/g

Ch48/Zoom Scan (7x7x9)/Cube 0: Measurement grid: dx=4mm, dy=4mm, dz=2.5mm

Reference Value = 0 V/m; Power Drift = 0.19 dB

Peak SAR (extrapolated) = 0.033 mW/g

SAR(1 g) = 0.000351 mW/g; SAR(10 g) = 2.24e-005 mW/g

Maximum value of SAR (measured) = 0.108 mW/g

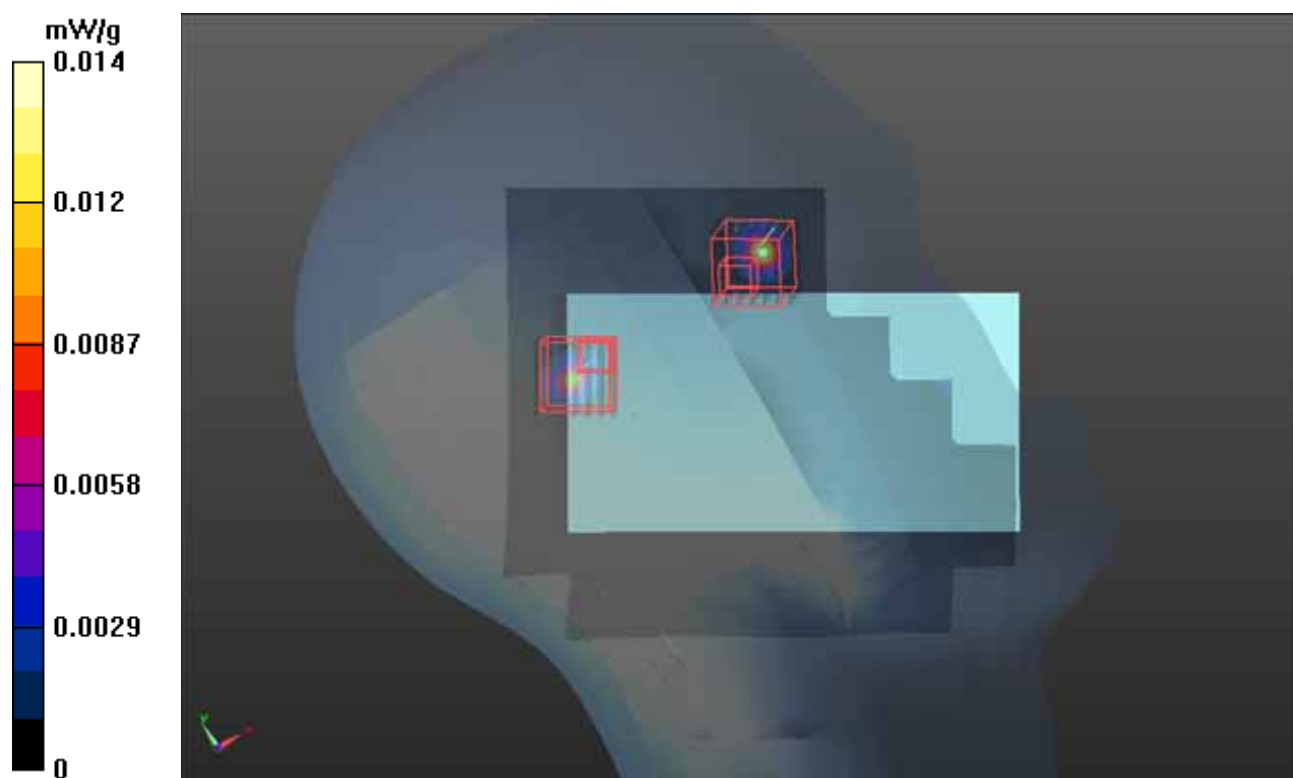

P21 802.11a_Right Cheek_Ch48_w_o MSR_Ant 1_w_o_Holster

DUT: 120703C13

Communication System: WLAN_5G; Frequency: 5240 MHz; Duty Cycle: 1:1

Medium: H5G_0811 Medium parameters used: $f = 5240$ MHz; $\sigma = 4.79$ mho/m; $\epsilon_r = 37.074$; $\rho = 1000$ kg/m³

Ambient Temperature : 21.6 °C ; Liquid Temperature : 20.2 °C

DASY5 Configuration:

- Probe: EX3DV4 - SN3590; ConvF(5.64, 5.64, 5.64); Calibrated: 2012/02/23;
- Sensor-Surface: 2mm (Mechanical Surface Detection)
- Electronics: DAE3 Sn579; Calibrated: 2012/04/27
- Phantom: SAM with CRP v5.0 Front; Type: QD000P40CD; Serial: TP:1653
- Measurement SW: DASY52, Version 52.8 (1); SEMCAD X Version 14.6.5 (6469)

Ch48/Area Scan (161x201x1): Measurement grid: dx=10mm, dy=10mm

Maximum value of SAR (interpolated) = 0.196 mW/g

Ch48/Zoom Scan (7x7x9)/Cube 0: Measurement grid: dx=4mm, dy=4mm, dz=2.5mm

Reference Value = 0.569 V/m; Power Drift = 0.19 dB

Peak SAR (extrapolated) = 0.00708 mW/g

SAR(1 g) = 1.66e-005 mW/g; SAR(10 g) = 7.44e-007 mW/g

Maximum value of SAR (measured) = 0.0507 mW/g

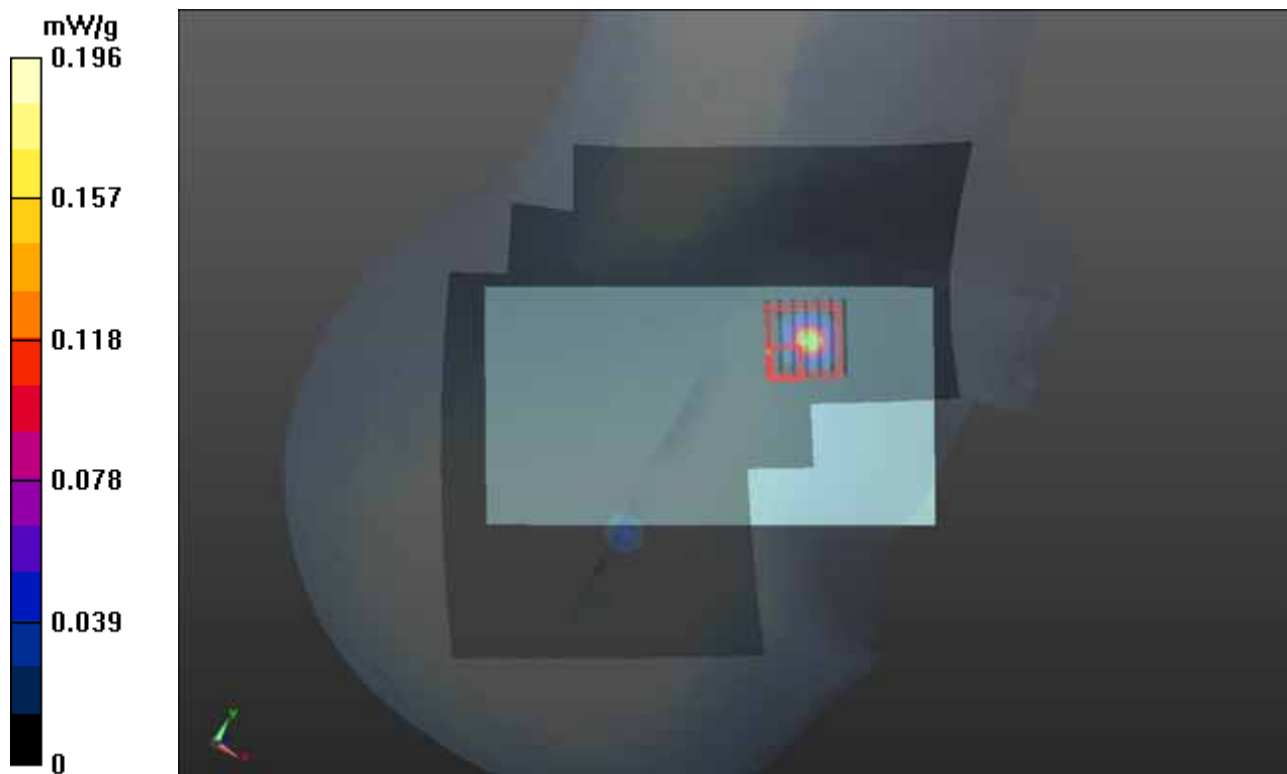

P22 802.11a_Right Cheek_Ch48_w MSR_Ant 1_w_o_Holster

DUT: 120703C13

Communication System: WLAN_5G; Frequency: 5240 MHz; Duty Cycle: 1:1

Medium: H5G_0811 Medium parameters used: $f = 5240$ MHz; $\sigma = 4.79$ mho/m; $\epsilon_r = 37.074$; $\rho = 1000$ kg/m³

Ambient Temperature : 21.6 °C ; Liquid Temperature : 20.2 °C

DASY5 Configuration:

- Probe: EX3DV4 - SN3590; ConvF(5.64, 5.64, 5.64); Calibrated: 2012/02/23;
- Sensor-Surface: 2mm (Mechanical Surface Detection)
- Electronics: DAE3 Sn579; Calibrated: 2012/04/27
- Phantom: SAM with CRP v5.0 Front; Type: QD000P40CD; Serial: TP:1653
- Measurement SW: DASY52, Version 52.8 (1); SEMCAD X Version 14.6.5 (6469)

Ch48/Area Scan (141x201x1): Measurement grid: dx=10mm, dy=10mm

Maximum value of SAR (interpolated) = 0.138 mW/g

Ch48/Zoom Scan (7x7x9)/Cube 0: Measurement grid: dx=4mm, dy=4mm, dz=2.5mm

Reference Value = 0 V/m; Power Drift = 0.00 dB

Peak SAR (extrapolated) = 0.036 mW/g

SAR(1 g) = 0.00103 mW/g; SAR(10 g) = n.a.

Maximum value of SAR (measured) = 0.0818 mW/g

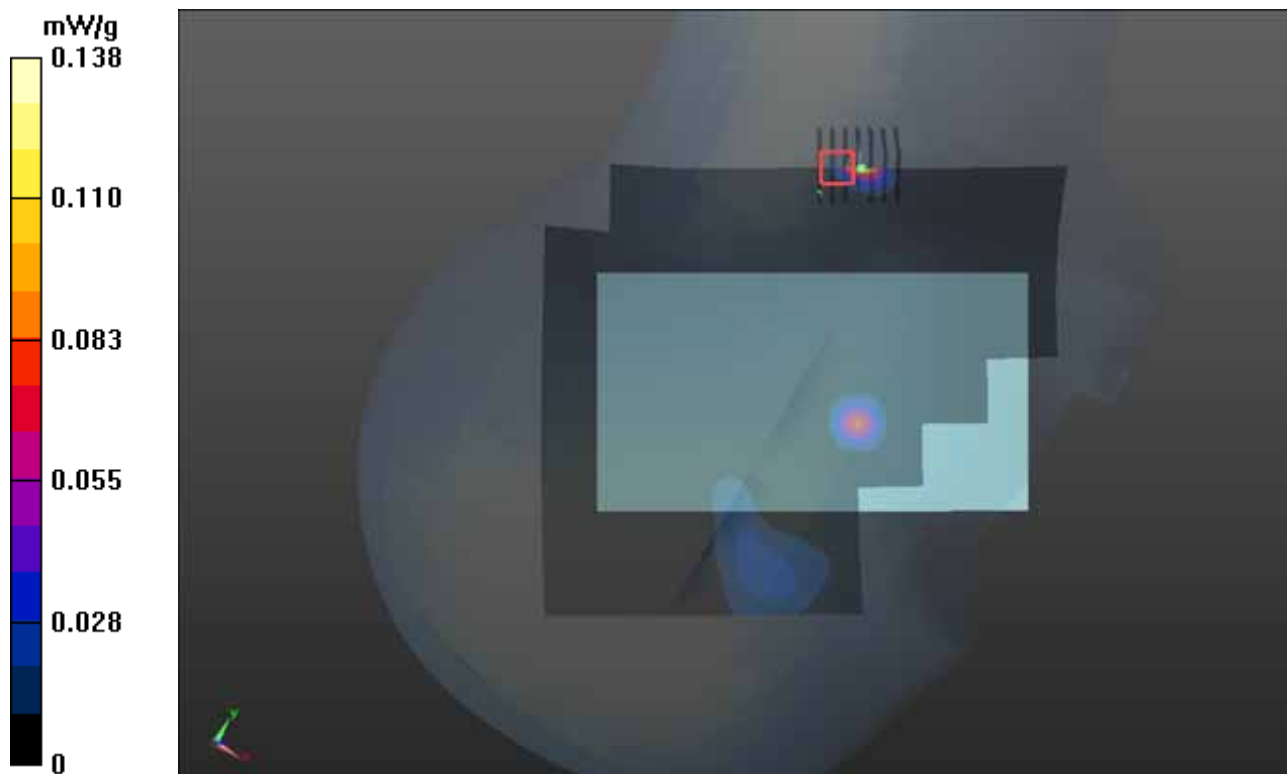

P23 802.11a_Right Tilted_Ch48_w MSR_Ant 1_w_o_Holster

DUT: 120703C13

Communication System: WLAN_5G; Frequency: 5240 MHz; Duty Cycle: 1:1

Medium: H5G_0811 Medium parameters used: $f = 5240$ MHz; $\sigma = 4.79$ mho/m; $\epsilon_r = 37.074$; $\rho = 1000$ kg/m³

Ambient Temperature : 21.6 °C ; Liquid Temperature : 20.2 °C

DASY5 Configuration:

- Probe: EX3DV4 - SN3590; ConvF(5.64, 5.64, 5.64); Calibrated: 2012/02/23;
- Sensor-Surface: 2mm (Mechanical Surface Detection)
- Electronics: DAE3 Sn579; Calibrated: 2012/04/27
- Phantom: SAM with CRP v5.0 Front; Type: QD000P40CD; Serial: TP:1653
- Measurement SW: DASY52, Version 52.8 (1); SEMCAD X Version 14.6.5 (6469)

Ch48/Area Scan (161x201x1): Measurement grid: dx=10mm, dy=10mm

Maximum value of SAR (interpolated) = 0.0128 mW/g

Ch48/Zoom Scan (7x7x9)/Cube 0: Measurement grid: dx=4mm, dy=4mm, dz=2.5mm

Reference Value = 0 V/m; Power Drift = 0.18 dB

Peak SAR (extrapolated) = 0.017 mW/g

SAR(1 g) = 0.000268 mW/g; SAR(10 g) = 2.67e-005 mW/g

Maximum value of SAR (measured) = 0.0644 mW/g

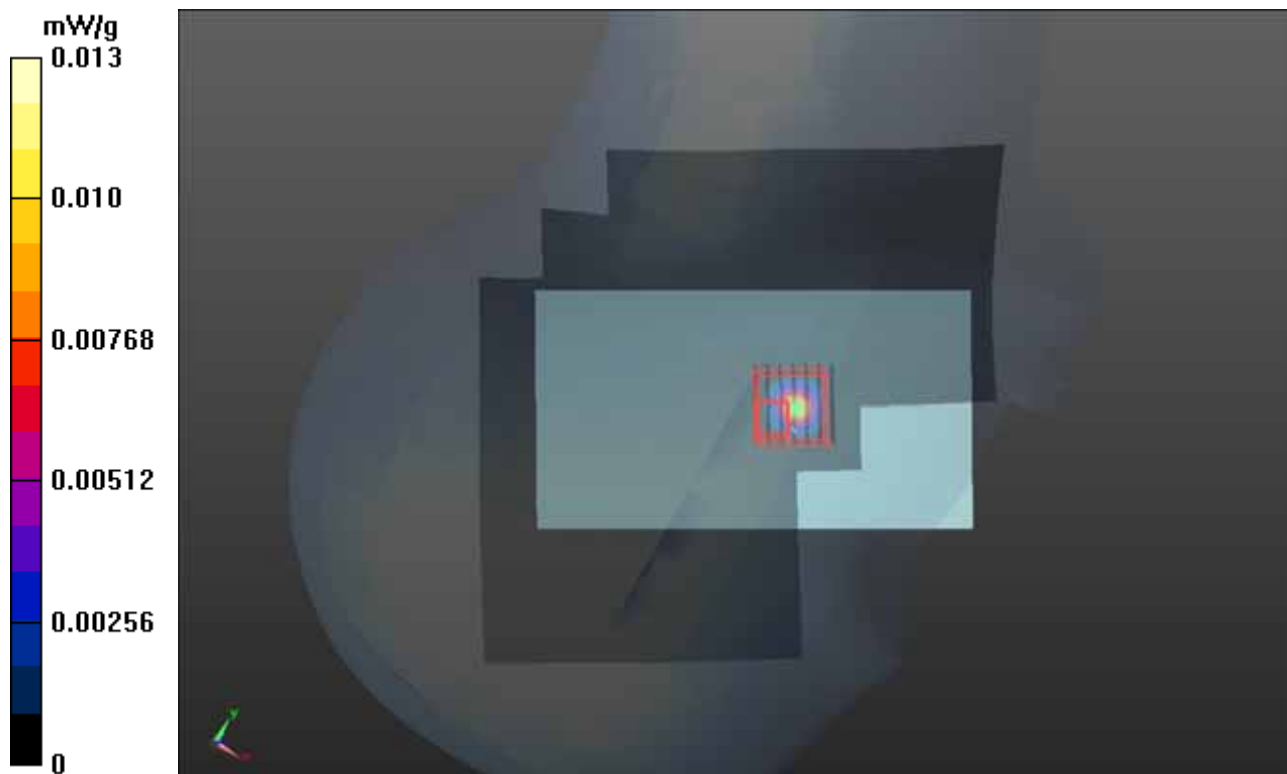

P24 802.11a_Left Cheek_Ch48_w MSR_Ant 1_w_o_Holster

DUT: 120703C13

Communication System: WLAN_5G; Frequency: 5240 MHz; Duty Cycle: 1:1

Medium: H5G_0811 Medium parameters used: $f = 5240$ MHz; $\sigma = 4.79$ mho/m; $\epsilon_r = 37.074$; $\rho = 1000$ kg/m³

Ambient Temperature : 21.6 °C ; Liquid Temperature : 20.2 °C

DASY5 Configuration:

- Probe: EX3DV4 - SN3590; ConvF(5.64, 5.64, 5.64); Calibrated: 2012/02/23;
- Sensor-Surface: 2mm (Mechanical Surface Detection)
- Electronics: DAE3 Sn579; Calibrated: 2012/04/27
- Phantom: SAM with CRP v5.0 Front; Type: QD000P40CD; Serial: TP:1653
- Measurement SW: DASY52, Version 52.8 (1); SEMCAD X Version 14.6.5 (6469)

Ch48/Area Scan (141x201x1): Measurement grid: dx=10mm, dy=10mm

Maximum value of SAR (interpolated) = 0.0455 mW/g

Ch48/Zoom Scan (7x7x9)/Cube 1: Measurement grid: dx=4mm, dy=4mm, dz=2.5mm

Reference Value = 0 V/m; Power Drift = 0.00 dB

Peak SAR (extrapolated) = 0.164 mW/g

SAR(1 g) = 0.019 mW/g; SAR(10 g) = 0.00638 mW/g

Maximum value of SAR (measured) = 0.0482 mW/g

Ch48/Zoom Scan (7x7x9)/Cube 0: Measurement grid: dx=4mm, dy=4mm, dz=2.5mm

Reference Value = 0 V/m; Power Drift = 0.00 dB

Peak SAR (extrapolated) = 0.028 mW/g

SAR(1 g) = 0.000295 mW/g; SAR(10 g) = 1.89e-005 mW/g

Maximum value of SAR (measured) = 0.0684 mW/g

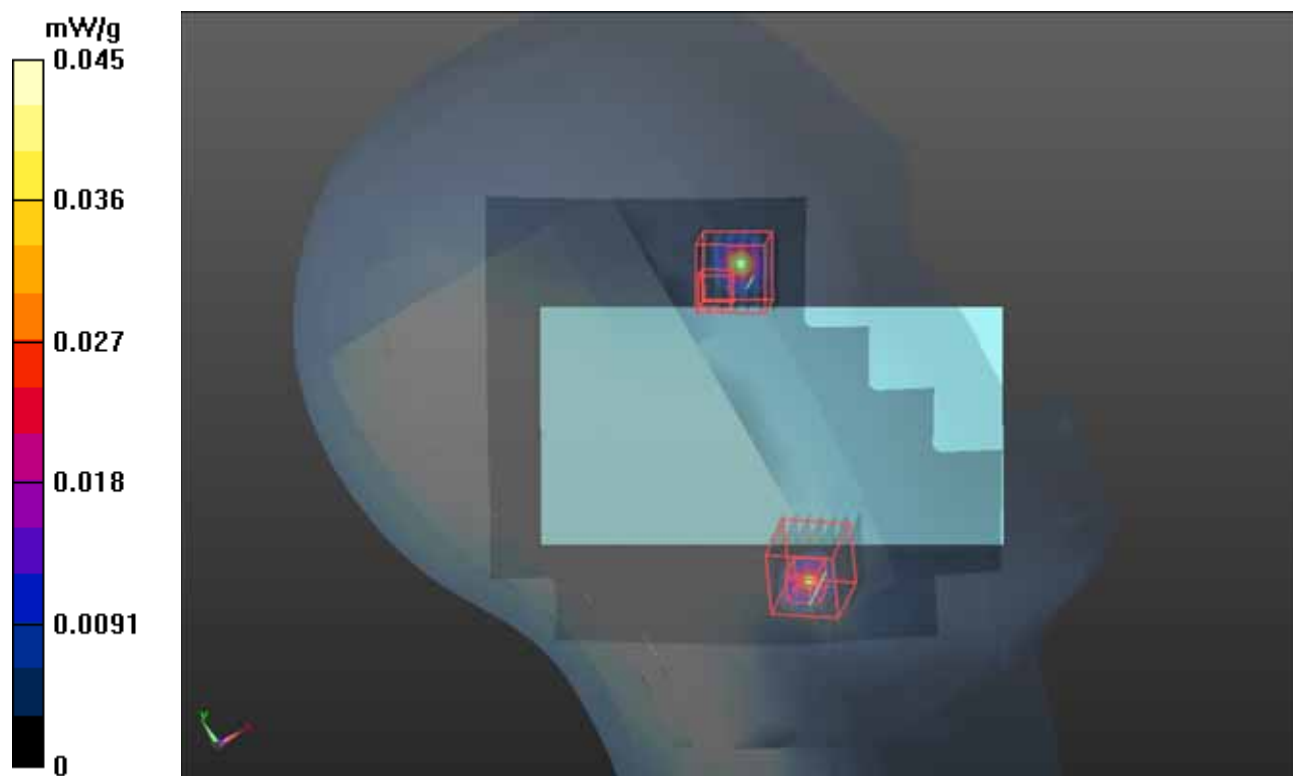

P25 802.11a_Left Tilted_Ch48_w MSR_Ant 1_w_o_Holster

DUT: 120703C13

Communication System: WLAN_5G; Frequency: 5240 MHz; Duty Cycle: 1:1

Medium: H5G_0811 Medium parameters used: $f = 5240$ MHz; $\sigma = 4.79$ mho/m; $\epsilon_r = 37.074$; $\rho = 1000$ kg/m³

Ambient Temperature : 21.6 °C ; Liquid Temperature : 20.2 °C

DASY5 Configuration:

- Probe: EX3DV4 - SN3590; ConvF(5.64, 5.64, 5.64); Calibrated: 2012/02/23;
- Sensor-Surface: 2mm (Mechanical Surface Detection)
- Electronics: DAE3 Sn579; Calibrated: 2012/04/27
- Phantom: SAM with CRP v5.0 Front; Type: QD000P40CD; Serial: TP:1653
- Measurement SW: DASY52, Version 52.8 (1); SEMCAD X Version 14.6.5 (6469)

Ch48/Area Scan (141x201x1): Measurement grid: dx=10mm, dy=10mm

Maximum value of SAR (interpolated) = 0.000136 mW/g

Ch48/Zoom Scan (7x7x9)/Cube 0: Measurement grid: dx=4mm, dy=4mm, dz=2.5mm

Reference Value = 0 V/m; Power Drift = 0.18 dB

Peak SAR (extrapolated) = 0.021 mW/g

SAR(1 g) = 0.000118 mW/g; SAR(10 g) = 1.16e-005 mW/g

Maximum value of SAR (measured) = 0.0212 mW/g

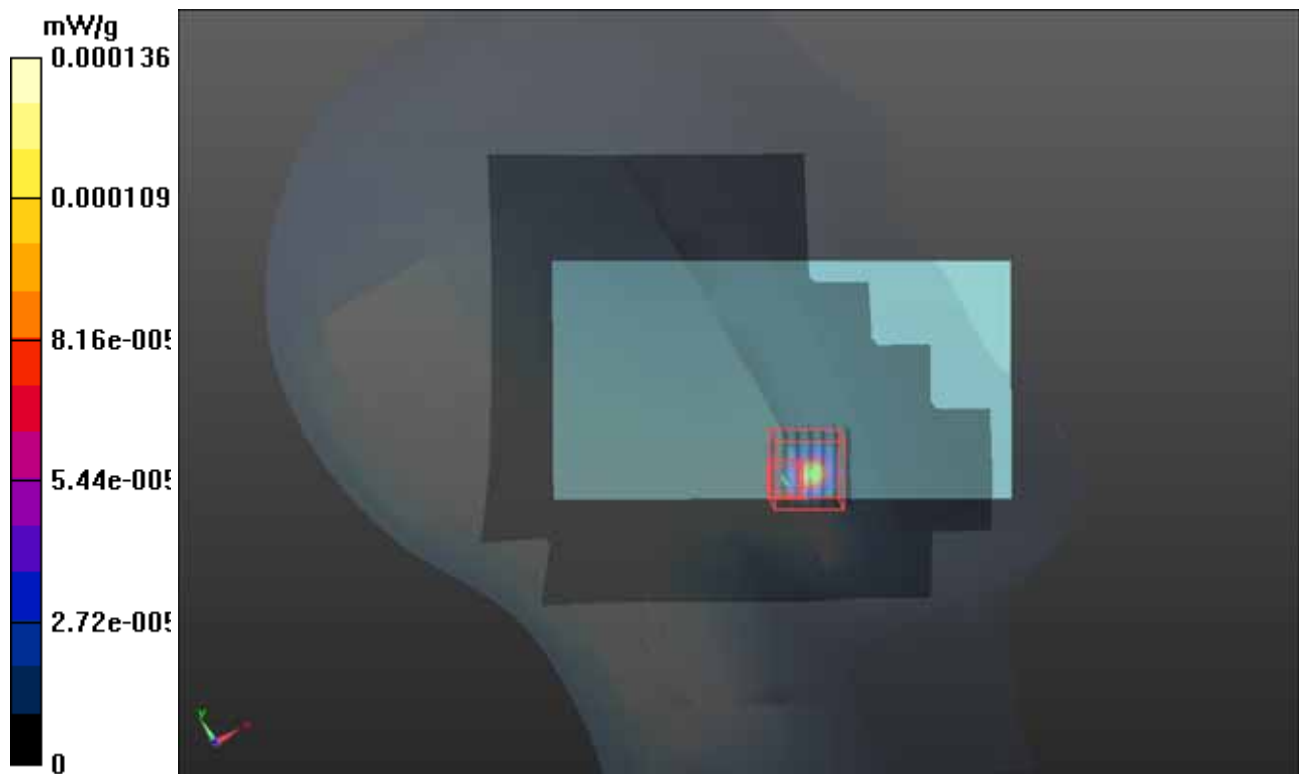

P28 802.11a_Right Cheek_Ch64_w MSR_Ant 0_w_o_Holster

DUT: 120703C13

Communication System: WLAN_5G; Frequency: 5320 MHz; Duty Cycle: 1:1

Medium: H5G_0811 Medium parameters used: $f = 5320$ MHz; $\sigma = 4.89$ mho/m; $\epsilon_r = 36.893$; $\rho = 1000$ kg/m³

Ambient Temperature : 21.6 °C ; Liquid Temperature : 20.2 °C

DASY5 Configuration:

- Probe: EX3DV4 - SN3590; ConvF(5.32, 5.32, 5.32); Calibrated: 2012/02/23;
- Sensor-Surface: 2mm (Mechanical Surface Detection)
- Electronics: DAE3 Sn579; Calibrated: 2012/04/27
- Phantom: SAM with CRP v5.0 Front; Type: QD000P40CD; Serial: TP:1653
- Measurement SW: DASY52, Version 52.8 (1); SEMCAD X Version 14.6.5 (6469)

Ch64/Area Scan (161x181x1): Measurement grid: dx=10mm, dy=10mm

Maximum value of SAR (interpolated) = 0.347 mW/g

Ch64/Zoom Scan (7x7x9)/Cube 0: Measurement grid: dx=4mm, dy=4mm, dz=2.5mm

Reference Value = 0 V/m; Power Drift = 0.00 dB

Peak SAR (extrapolated) = 0.527 mW/g

SAR(1 g) = 0.014 mW/g; SAR(10 g) = 0.00258 mW/g

Maximum value of SAR (measured) = 0.207 mW/g

Ch64/Zoom Scan (7x7x9)/Cube 1: Measurement grid: dx=4mm, dy=4mm, dz=2.5mm

Reference Value = 0 V/m; Power Drift = 0.00 dB

Peak SAR (extrapolated) = 0.141 mW/g

SAR(1 g) = 0.000245 mW/g; SAR(10 g) = 7.47e-006 mW/g

Maximum value of SAR (measured) = 0.141 mW/g

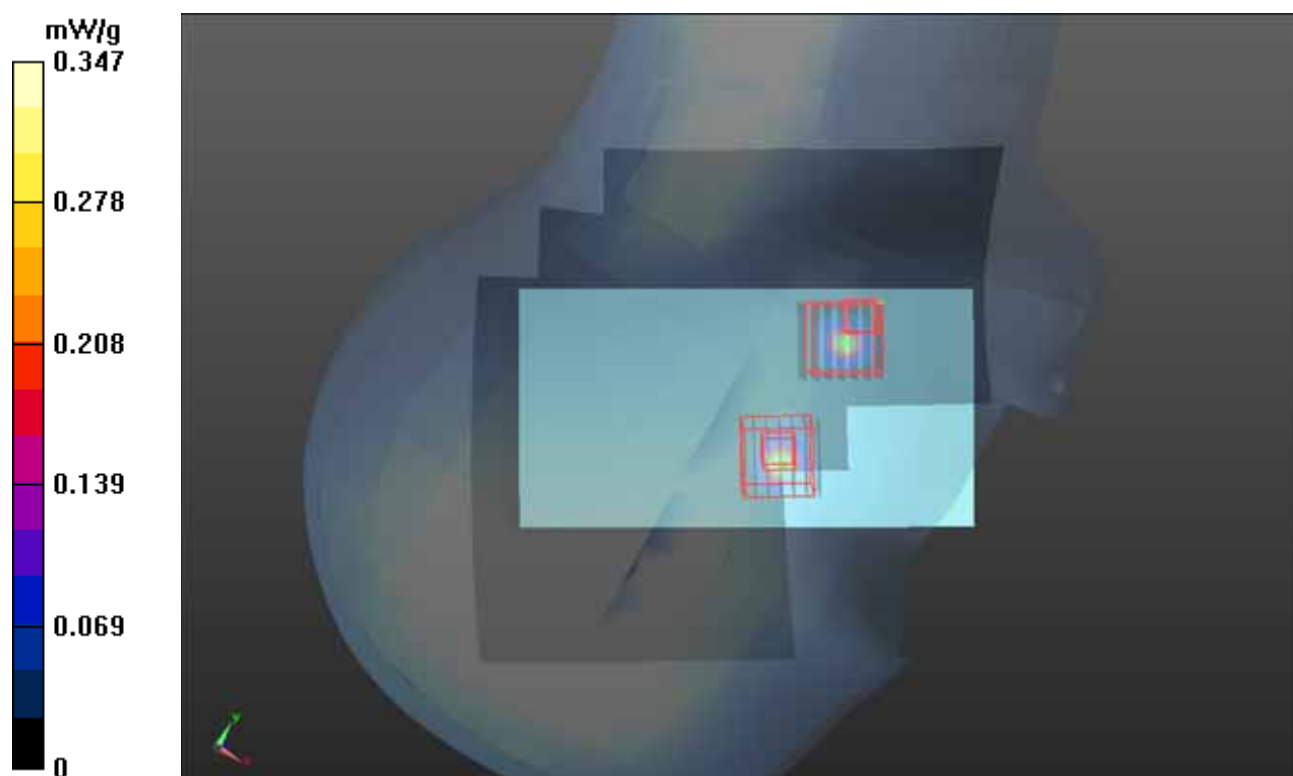

1g/10g Averaged SAR

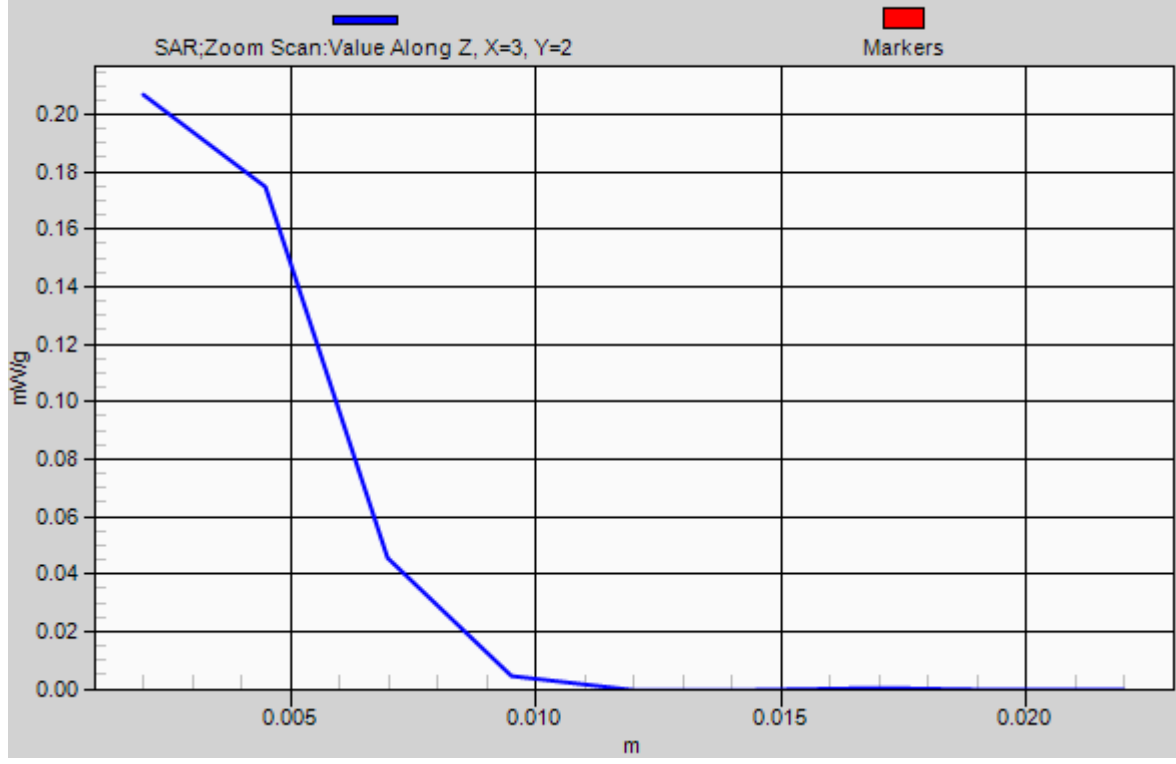

P29 802.11a_Right Tilted_Ch64_w MSR_Ant 0_w_o_Holster

DUT: 120703C13

Communication System: WLAN_5G; Frequency: 5320 MHz; Duty Cycle: 1:1

Medium: H5G_0812 Medium parameters used: $f = 5320$ MHz; $\sigma = 4.835$ mho/m; $\epsilon_r = 36.74$; $\rho = 1000$ kg/m³

Ambient Temperature : 21.7 °C ; Liquid Temperature : 20.3 °C

DASY5 Configuration:

- Probe: EX3DV4 - SN3590; ConvF(5.32, 5.32, 5.32); Calibrated: 2012/02/23;
- Sensor-Surface: 2mm (Mechanical Surface Detection)
- Electronics: DAE3 Sn579; Calibrated: 2012/04/27
- Phantom: SAM with CRP v5.0 Front; Type: QD000P40CD; Serial: TP:1653
- Measurement SW: DASY52, Version 52.8 (1); SEMCAD X Version 14.6.5 (6469)

Ch64/Area Scan (161x181x1): Measurement grid: dx=10mm, dy=10mm

Maximum value of SAR (interpolated) = 0.0146 mW/g

Ch64/Zoom Scan (7x7x9)/Cube 0: Measurement grid: dx=4mm, dy=4mm, dz=2.5mm

Reference Value = 0 V/m; Power Drift = 0.02 dB

Peak SAR (extrapolated) = 0.075 mW/g

SAR(1 g) = 0.00707 mW/g; SAR(10 g) = 0.00154 mW/g

Maximum value of SAR (measured) = 0.0131 mW/g



P30 802.11a_Left Cheek_Ch64_w MSR_Ant 0_w_o_Holstery

DUT: 120703C13

Communication System: WLAN_5G; Frequency: 5320 MHz; Duty Cycle: 1:1

Medium: H5G_0812 Medium parameters used: $f = 5320$ MHz; $\sigma = 4.835$ mho/m; $\epsilon_r = 36.74$; $\rho = 1000$ kg/m³

Ambient Temperature : 21.7 °C ; Liquid Temperature : 20.3 °C

DASY5 Configuration:

- Probe: EX3DV4 - SN3590; ConvF(5.32, 5.32, 5.32); Calibrated: 2012/02/23;
- Sensor-Surface: 2mm (Mechanical Surface Detection)
- Electronics: DAE3 Sn579; Calibrated: 2012/04/27
- Phantom: SAM with CRP v5.0 Front; Type: QD000P40CD; Serial: TP:1653
- Measurement SW: DASY52, Version 52.8 (1); SEMCAD X Version 14.6.5 (6469)

Ch64/Area Scan (161x181x1): Measurement grid: dx=10mm, dy=10mm

Maximum value of SAR (interpolated) = 0.0724 mW/g

Ch64/Zoom Scan (7x7x9)/Cube 0: Measurement grid: dx=4mm, dy=4mm, dz=2.5mm

Reference Value = 3.857 V/m; Power Drift = -0.16 dB

Peak SAR (extrapolated) = 0.083 mW/g

SAR(1 g) = 0.00246 mW/g; SAR(10 g) = 0.000428 mW/g

Maximum value of SAR (measured) = 0.0509 mW/g

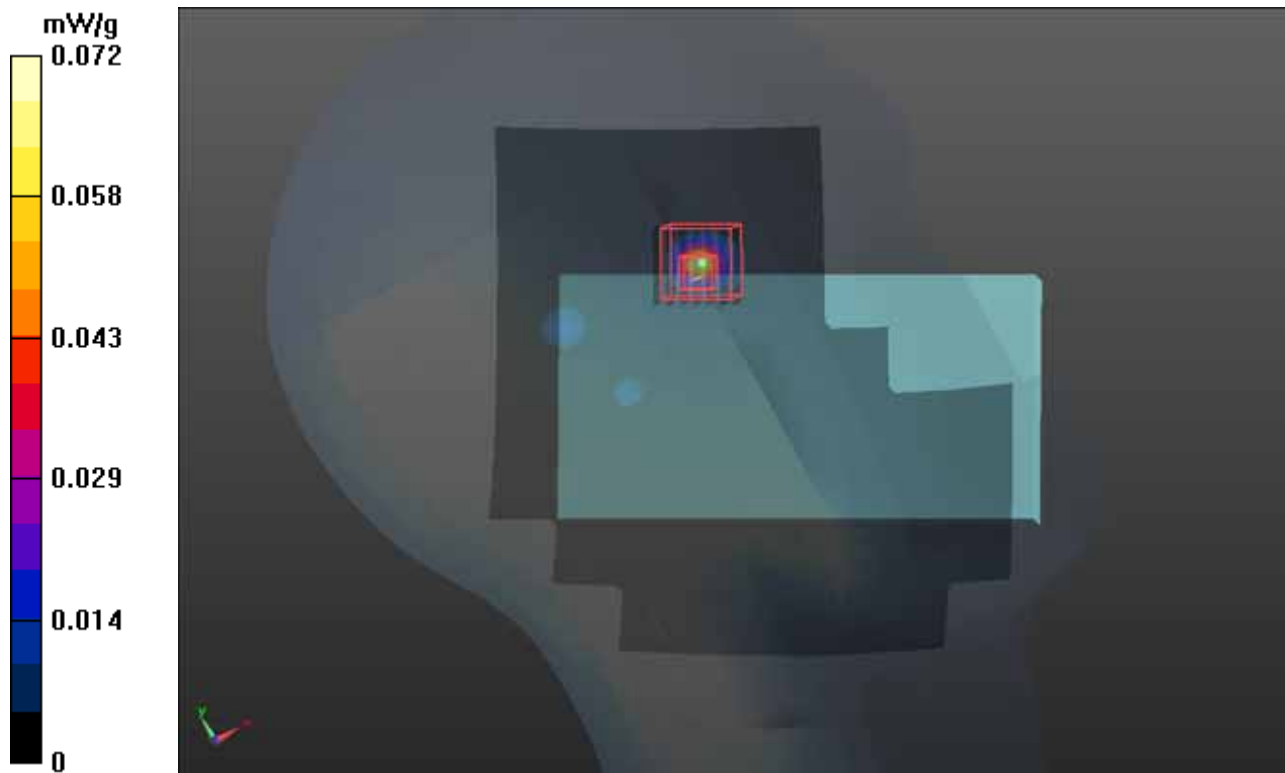

P31 802.11a_Left Tilted_Ch64_w MSR_Ant 0_w_o_Holstery

DUT: 120703C13

Communication System: WLAN_5G; Frequency: 5320 MHz; Duty Cycle: 1:1

Medium: H5G_0812 Medium parameters used: $f = 5320$ MHz; $\sigma = 4.835$ mho/m; $\epsilon_r = 36.74$; $\rho = 1000$ kg/m³

Ambient Temperature : 21.7 °C ; Liquid Temperature : 20.3 °C

DASY5 Configuration:

- Probe: EX3DV4 - SN3590; ConvF(5.32, 5.32, 5.32); Calibrated: 2012/02/23;
- Sensor-Surface: 2mm (Mechanical Surface Detection)
- Electronics: DAE3 Sn579; Calibrated: 2012/04/27
- Phantom: SAM with CRP v5.0 Front; Type: QD000P40CD; Serial: TP:1653
- Measurement SW: DASY52, Version 52.8 (1); SEMCAD X Version 14.6.5 (6469)

Ch64/Area Scan (161x181x1): Measurement grid: dx=10mm, dy=10mm

Maximum value of SAR (interpolated) = 0.0347 mW/g

Ch64/Zoom Scan (7x7x9)/Cube 1: Measurement grid: dx=4mm, dy=4mm, dz=2.5mm

Reference Value = 0 V/m; Power Drift = 0.01 dB

Peak SAR (extrapolated) = 0.129 mW/g

SAR(1 g) = 0.012 mW/g; SAR(10 g) = 0.00253 mW/g

Maximum value of SAR (measured) = 0.0325 mW/g

Ch64/Zoom Scan (7x7x9)/Cube 0: Measurement grid: dx=4mm, dy=4mm, dz=2.5mm

Reference Value = 0 V/m; Power Drift = 0.01 dB

Peak SAR (extrapolated) = 0 mW/g

SAR(1 g) = n.a. ; SAR(10 g) = n.a.

Maximum value of SAR (measured) = 0.0357 mW/g

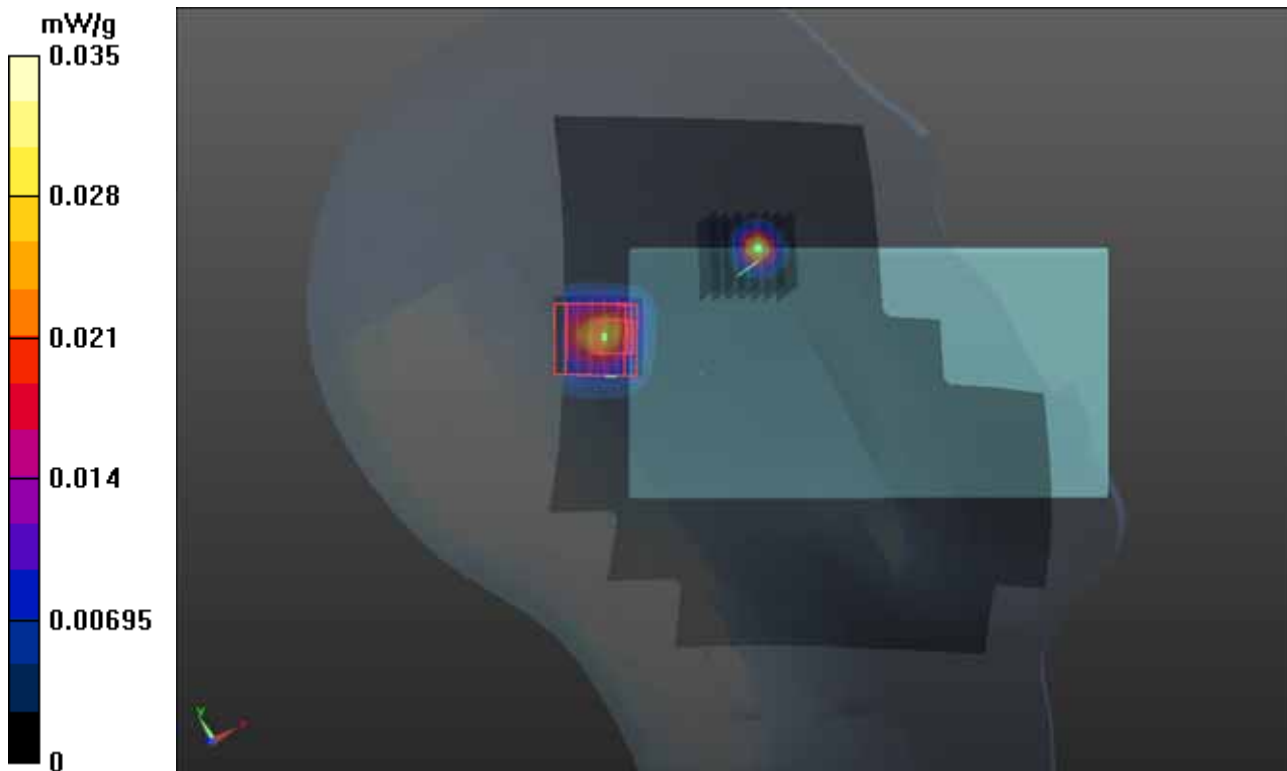

P33 802.11a_Right Cheek_Ch64_w_o MSR_Ant 1_w_o_Holstery

DUT: 120703C13

Communication System: WLAN_5G; Frequency: 5320 MHz; Duty Cycle: 1:1

Medium: H5G_0812 Medium parameters used: $f = 5320$ MHz; $\sigma = 4.835$ mho/m; $\epsilon_r = 36.74$; $\rho = 1000$ kg/m³

Ambient Temperature : 21.7 °C ; Liquid Temperature : 20.3 °C

DASY5 Configuration:

- Probe: EX3DV4 - SN3590; ConvF(5.32, 5.32, 5.32); Calibrated: 2012/02/23;
- Sensor-Surface: 2mm (Mechanical Surface Detection)
- Electronics: DAE3 Sn579; Calibrated: 2012/04/27
- Phantom: SAM with CRP v5.0 Front; Type: QD000P40CD; Serial: TP:1653
- Measurement SW: DASY52, Version 52.8 (1); SEMCAD X Version 14.6.5 (6469)

Ch64/Area Scan (161x181x1): Measurement grid: dx=10mm, dy=10mm

Maximum value of SAR (interpolated) = 0.0230 mW/g

Ch64/Zoom Scan (7x7x9)/Cube 0: Measurement grid: dx=4mm, dy=4mm, dz=2.5mm

Reference Value = 0.295 V/m; Power Drift = 0.14 dB

Peak SAR (extrapolated) = 0.169 mW/g

SAR(1 g) = 0.014 mW/g; SAR(10 g) = 0.00208 mW/g

Maximum value of SAR (measured) = 0.111 mW/g

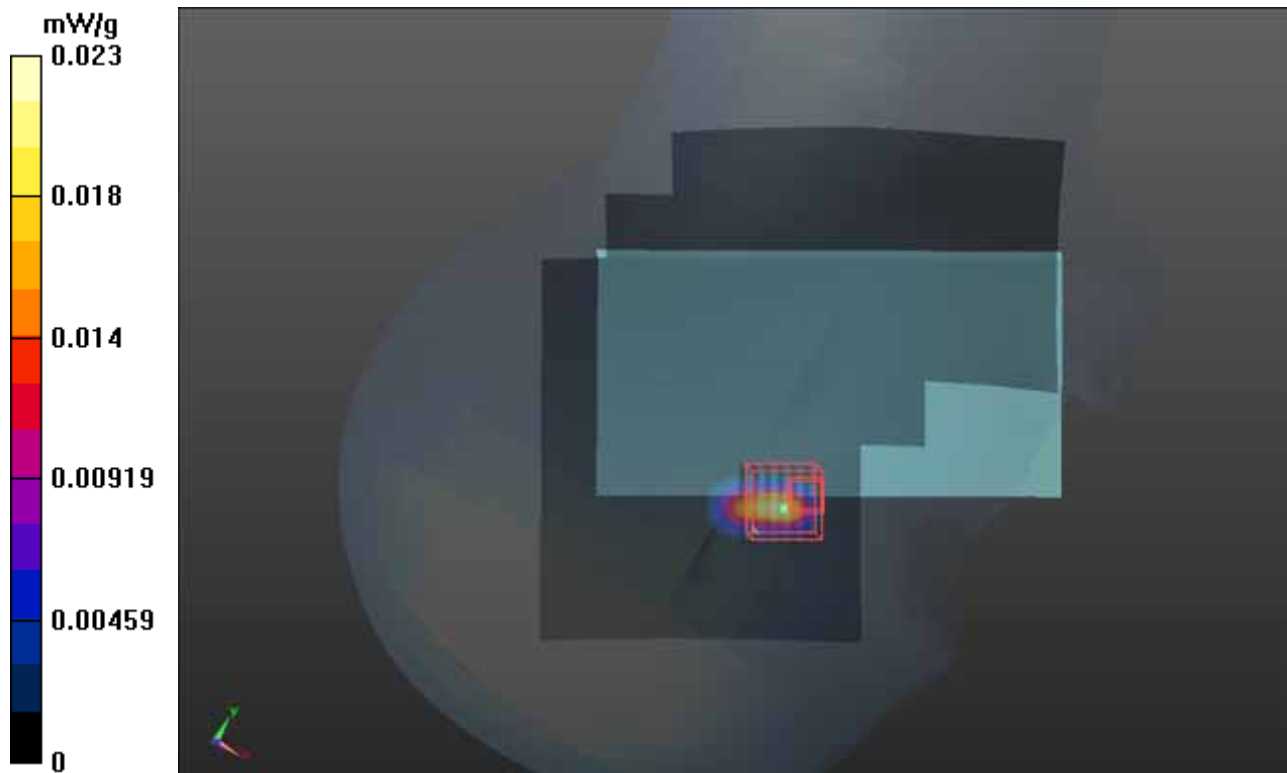

P34 802.11a_Right Cheek_Ch64_w MSR_Ant 1_w_o_Holstery

DUT: 120703C13

Communication System: WLAN_5G; Frequency: 5320 MHz; Duty Cycle: 1:1

Medium: H5G_0812 Medium parameters used: $f = 5320$ MHz; $\sigma = 4.835$ mho/m; $\epsilon_r = 36.74$; $\rho = 1000$ kg/m³

Ambient Temperature : 21.7 °C ; Liquid Temperature : 20.3 °C

DASY5 Configuration:

- Probe: EX3DV4 - SN3590; ConvF(5.32, 5.32, 5.32); Calibrated: 2012/02/23;
- Sensor-Surface: 2mm (Mechanical Surface Detection)
- Electronics: DAE3 Sn579; Calibrated: 2012/04/27
- Phantom: SAM with CRP v5.0 Front; Type: QD000P40CD; Serial: TP:1653
- Measurement SW: DASY52, Version 52.8 (1); SEMCAD X Version 14.6.5 (6469)

Ch64/Area Scan (161x181x1): Measurement grid: dx=10mm, dy=10mm

Maximum value of SAR (interpolated) = 0.0691 mW/g

Ch64/Zoom Scan (7x7x9)/Cube 0: Measurement grid: dx=4mm, dy=4mm, dz=2.5mm

Reference Value = 0 V/m; Power Drift = 0.10 dB

Peak SAR (extrapolated) = 0.000521 mW/g

SAR(1 g) = 5.22e-006 mW/g; SAR(10 g) = 3.32e-007 mW/g

Maximum value of SAR (measured) = 0.0358 mW/g

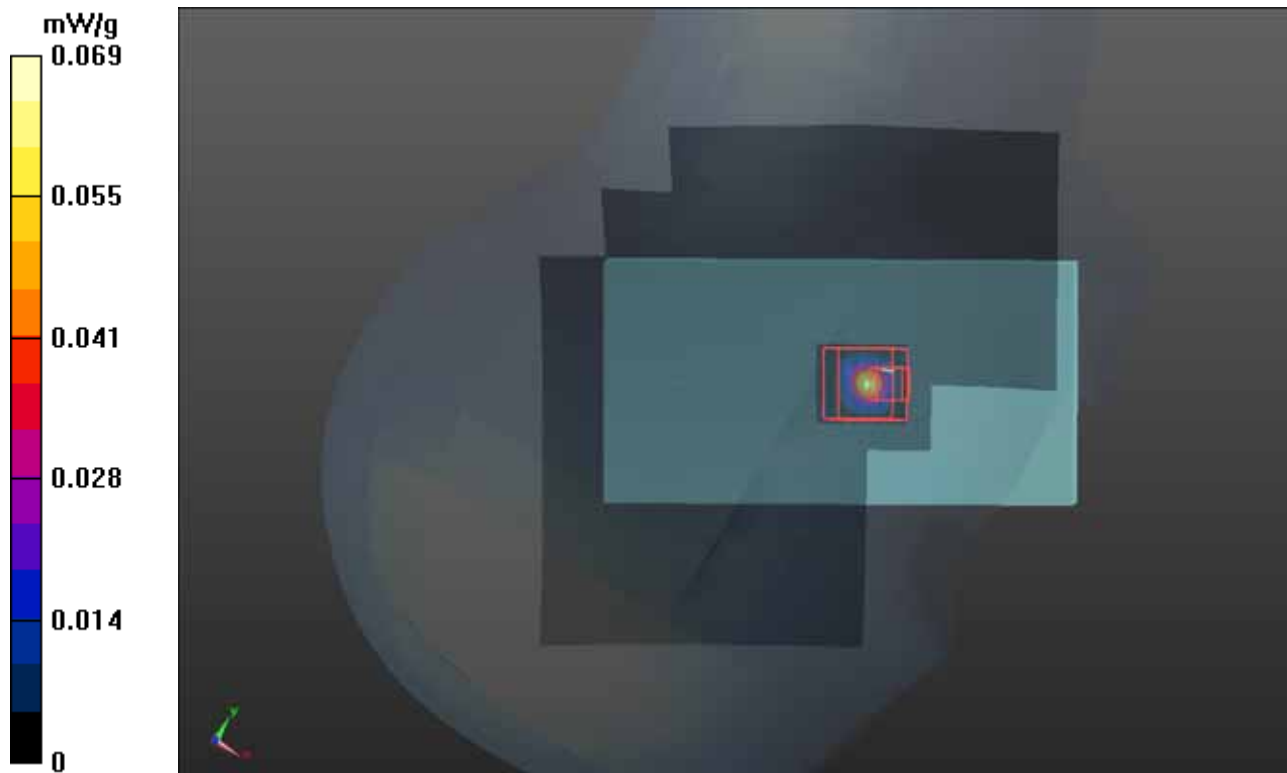

P35 802.11a_Right Tilted_Ch64_w_o MSR_Ant 1_w_o_Holstery

DUT: 120703C13

Communication System: WLAN_5G; Frequency: 5320 MHz; Duty Cycle: 1:1

Medium: H5G_0812 Medium parameters used: $f = 5320$ MHz; $\sigma = 4.835$ mho/m; $\epsilon_r = 36.74$; $\rho = 1000$ kg/m³

Ambient Temperature : 21.7 °C ; Liquid Temperature : 20.3 °C

DASY5 Configuration:

- Probe: EX3DV4 - SN3590; ConvF(5.32, 5.32, 5.32); Calibrated: 2012/02/23;
- Sensor-Surface: 2mm (Mechanical Surface Detection)
- Electronics: DAE3 Sn579; Calibrated: 2012/04/27
- Phantom: SAM with CRP v5.0 Front; Type: QD000P40CD; Serial: TP:1653
- Measurement SW: DASY52, Version 52.8 (1); SEMCAD X Version 14.6.5 (6469)

Ch64/Area Scan (161x181x1): Measurement grid: dx=10mm, dy=10mm

Maximum value of SAR (interpolated) = 0.00963 mW/g

Ch64/Zoom Scan (7x7x9)/Cube 0: Measurement grid: dx=4mm, dy=4mm, dz=2.5mm

Reference Value = 0 V/m; Power Drift = 0.10 dB

Peak SAR (extrapolated) = 0.322 mW/g

SAR(1 g) = 0.00173 mW/g; SAR(10 g) = 0.000343 mW/g

Maximum value of SAR (measured) = 0.322 mW/g

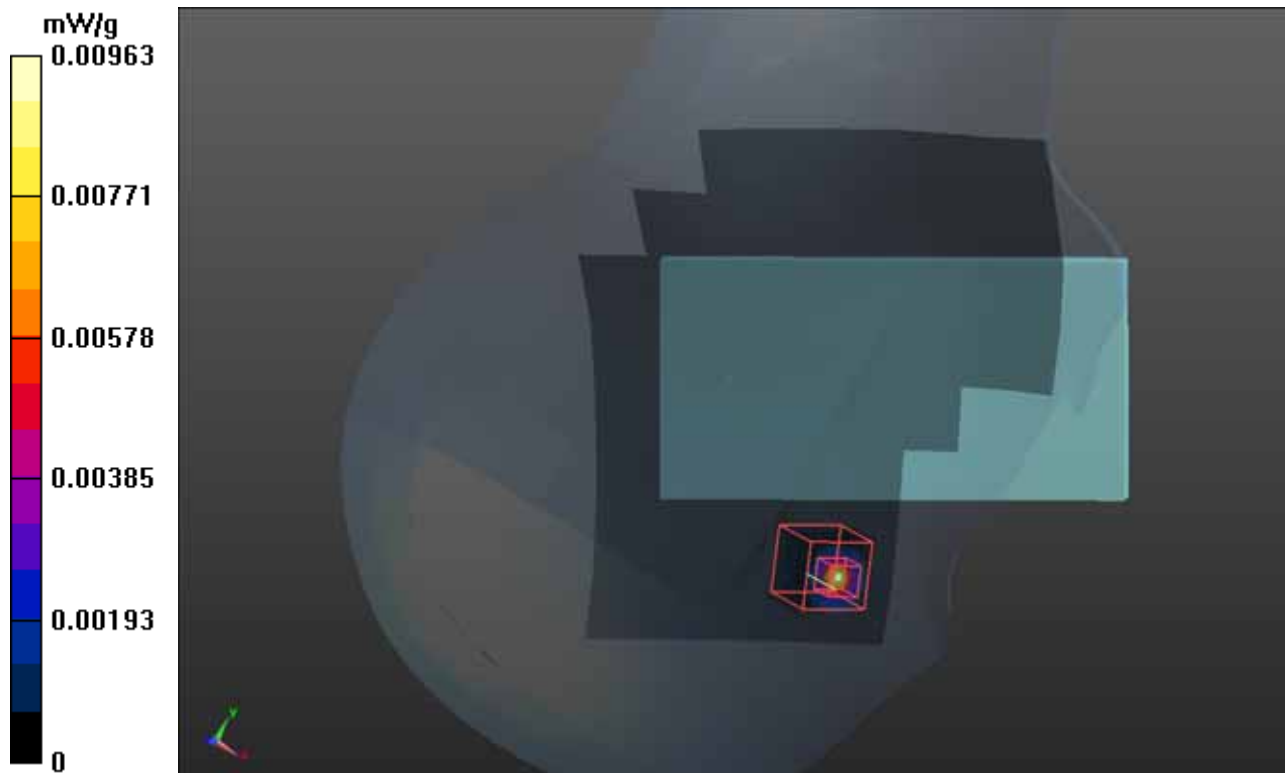

P36 802.11a_Left Cheek_Ch64_w_o MSR_Ant 1_w_o_Holstery

DUT: 120703C13

Communication System: WLAN_5G; Frequency: 5320 MHz; Duty Cycle: 1:1

Medium: H5G_0812 Medium parameters used: $f = 5320$ MHz; $\sigma = 4.835$ mho/m; $\epsilon_r = 36.74$; $\rho = 1000$ kg/m³

Ambient Temperature : 21.7 °C ; Liquid Temperature : 20.3 °C

DASY5 Configuration:

- Probe: EX3DV4 - SN3590; ConvF(5.32, 5.32, 5.32); Calibrated: 2012/02/23;
- Sensor-Surface: 2mm (Mechanical Surface Detection)
- Electronics: DAE3 Sn579; Calibrated: 2012/04/27
- Phantom: SAM with CRP v5.0 Front; Type: QD000P40CD; Serial: TP:1653
- Measurement SW: DASY52, Version 52.8 (1); SEMCAD X Version 14.6.5 (6469)

Ch64/Area Scan (161x181x1): Measurement grid: dx=10mm, dy=10mm

Maximum value of SAR (interpolated) = 0.0415 mW/g

Ch64/Zoom Scan (7x7x9)/Cube 0: Measurement grid: dx=4mm, dy=4mm, dz=2.5mm

Reference Value = 0.634 V/m; Power Drift = 0.09 dB

Peak SAR (extrapolated) = 0.084 mW/g

SAR(1 g) = 0.00194 mW/g; SAR(10 g) = 0.000186 mW/g

Maximum value of SAR (measured) = 0.0838 mW/g

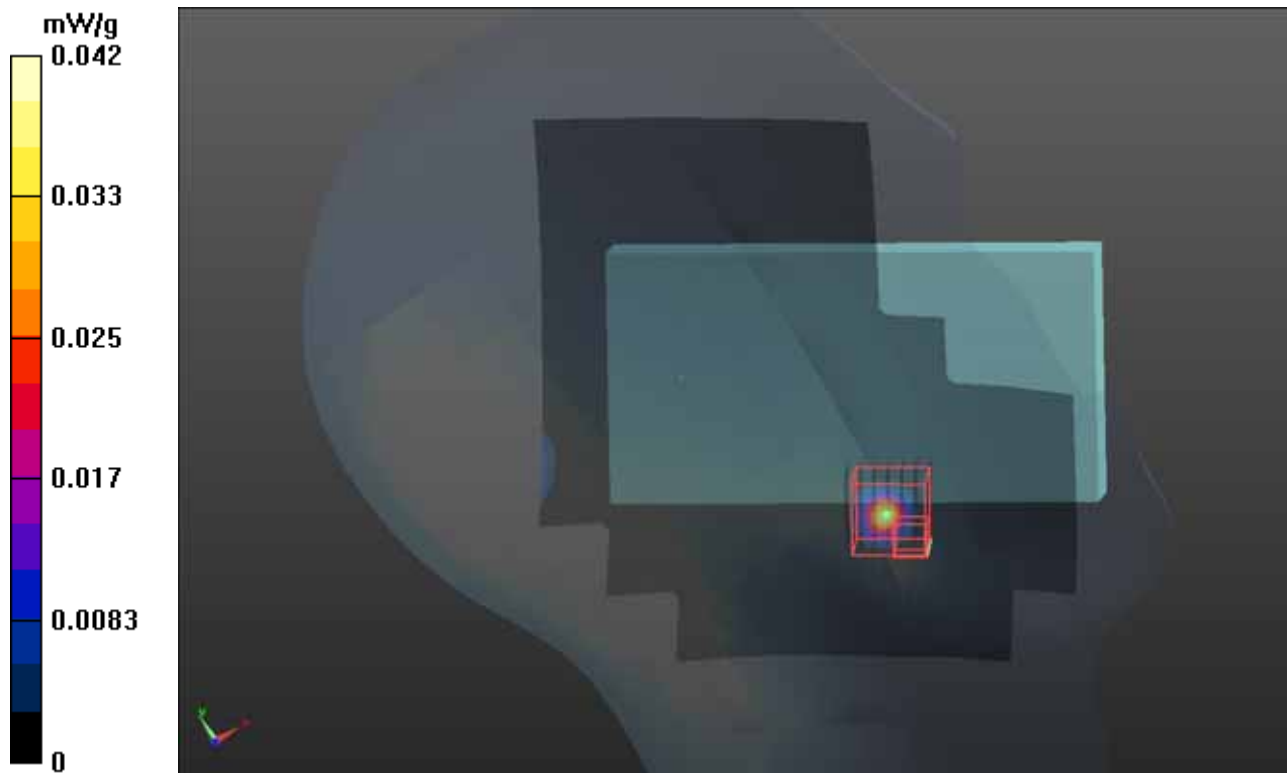

P37 802.11a_Left Tilted_Ch64_w_o MSR_Ant 1_w_o_Holstery

DUT: 120703C13

Communication System: WLAN_5G; Frequency: 5320 MHz; Duty Cycle: 1:1

Medium: H5G_0812 Medium parameters used: $f = 5320$ MHz; $\sigma = 4.835$ mho/m; $\epsilon_r = 36.74$; $\rho = 1000$ kg/m³

Ambient Temperature : 21.7 °C ; Liquid Temperature : 20.3 °C

DASY5 Configuration:

- Probe: EX3DV4 - SN3590; ConvF(5.32, 5.32, 5.32); Calibrated: 2012/02/23;
- Sensor-Surface: 2mm (Mechanical Surface Detection)
- Electronics: DAE3 Sn579; Calibrated: 2012/04/27
- Phantom: SAM with CRP v5.0 Front; Type: QD000P40CD; Serial: TP:1653
- Measurement SW: DASY52, Version 52.8 (1); SEMCAD X Version 14.6.5 (6469)

Ch64/Area Scan (161x181x1): Measurement grid: dx=10mm, dy=10mm

Maximum value of SAR (interpolated) = 0.0212 mW/g

Ch64/Zoom Scan (7x7x9)/Cube 1: Measurement grid: dx=4mm, dy=4mm, dz=2.5mm

Reference Value = 0 V/m; Power Drift = 0.11 dB

Peak SAR (extrapolated) = 0.073 mW/g

SAR(1 g) = 0.00794 mW/g; SAR(10 g) = 0.00231 mW/g

Maximum value of SAR (measured) = 0.0419 mW/g

Ch64/Zoom Scan (7x7x9)/Cube 0: Measurement grid: dx=4mm, dy=4mm, dz=2.5mm

Reference Value = 0 V/m; Power Drift = 0.11 dB

Peak SAR (extrapolated) = 0.207 mW/g

SAR(1 g) = 0.000953 mW/g; SAR(10 g) = 9.95e-005 mW/g

Maximum value of SAR (measured) = 0.207 mW/g

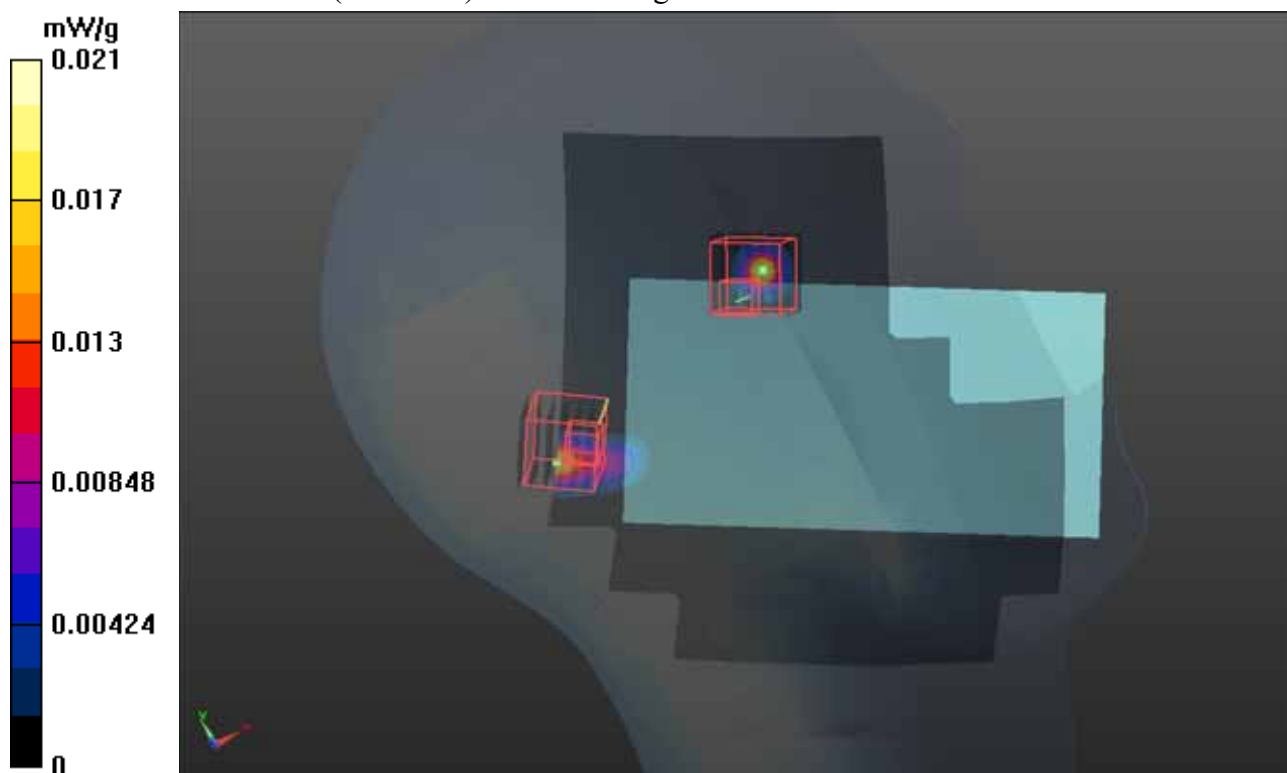

P40 802.11a_Right Cheek_Ch104_w MSR_Ant 0_w_o_Holstery

DUT: 120703C13

Communication System: WLAN_5G; Frequency: 5520 MHz; Duty Cycle: 1:1

Medium: H5G_0812 Medium parameters used: $f = 5520$ MHz; $\sigma = 5.08$ mho/m; $\epsilon_r = 36.326$; $\rho = 1000$ kg/m³

Ambient Temperature : 21.7 °C ; Liquid Temperature : 20.3 °C

DASY5 Configuration:

- Probe: EX3DV4 - SN3590; ConvF(5.13, 5.13, 5.13); Calibrated: 2012/02/23;
- Sensor-Surface: 2mm (Mechanical Surface Detection)
- Electronics: DAE3 Sn579; Calibrated: 2012/04/27
- Phantom: SAM with CRP v5.0 Front; Type: QD000P40CD; Serial: TP:1653
- Measurement SW: DASY52, Version 52.8 (1); SEMCAD X Version 14.6.5 (6469)

Ch104/Area Scan (161x181x1): Measurement grid: dx=10mm, dy=10mm

Maximum value of SAR (interpolated) = 0.00201 mW/g

Ch104/Zoom Scan (7x7x9)/Cube 0: Measurement grid: dx=4mm, dy=4mm, dz=2.5mm

Reference Value = 0 V/m; Power Drift = 0.14 dB

Peak SAR (extrapolated) = 0.00134 mW/g

SAR(1 g) = 3.53e-005 mW/g; SAR(10 g) = 3.53e-006 mW/g

Maximum value of SAR (measured) = 0.0121 mW/g

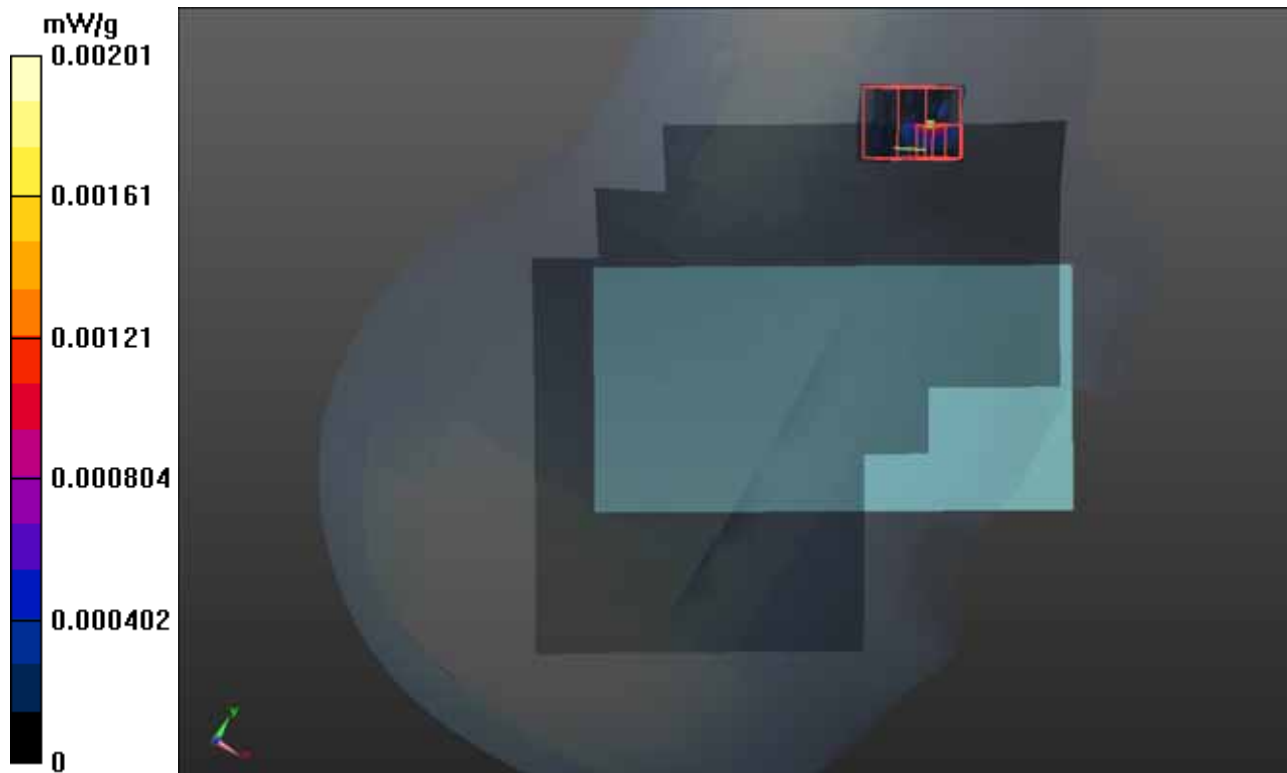

P41 802.11a_Right Tilted_Ch104_w MSR_Ant 0_w_o_Holstery

DUT: 120703C13

Communication System: WLAN_5G; Frequency: 5520 MHz; Duty Cycle: 1:1

Medium: H5G_0812 Medium parameters used: $f = 5520$ MHz; $\sigma = 5.08$ mho/m; $\epsilon_r = 36.326$; $\rho = 1000$ kg/m³

Ambient Temperature : 21.7 °C ; Liquid Temperature : 20.3 °C

DASY5 Configuration:

- Probe: EX3DV4 - SN3590; ConvF(5.13, 5.13, 5.13); Calibrated: 2012/02/23;
- Sensor-Surface: 2mm (Mechanical Surface Detection)
- Electronics: DAE3 Sn579; Calibrated: 2012/04/27
- Phantom: SAM with CRP v5.0 Front; Type: QD000P40CD; Serial: TP:1653
- Measurement SW: DASY52, Version 52.8 (1); SEMCAD X Version 14.6.5 (6469)

Ch104/Area Scan (161x181x1): Measurement grid: dx=10mm, dy=10mm

Maximum value of SAR (interpolated) = 0.0125 mW/g

Ch104/Zoom Scan (7x7x9)/Cube 0: Measurement grid: dx=4mm, dy=4mm, dz=2.5mm

Reference Value = 0 V/m; Power Drift = 0.12 dB

Peak SAR (extrapolated) = 0.106 mW/g

SAR(1 g) = 0.0093 mW/g; SAR(10 g) = 0.00198 mW/g

Maximum value of SAR (measured) = 0.0818 mW/g

Ch104/Zoom Scan (7x7x9)/Cube 1: Measurement grid: dx=4mm, dy=4mm, dz=2.5mm

Reference Value = 0 V/m; Power Drift = 0.12 dB

Peak SAR (extrapolated) = 0.015 mW/g

SAR(1 g) = 0.000376 mW/g; SAR(10 g) = 4.22e-005 mW/g

Maximum value of SAR (measured) = 0.0135 mW/g

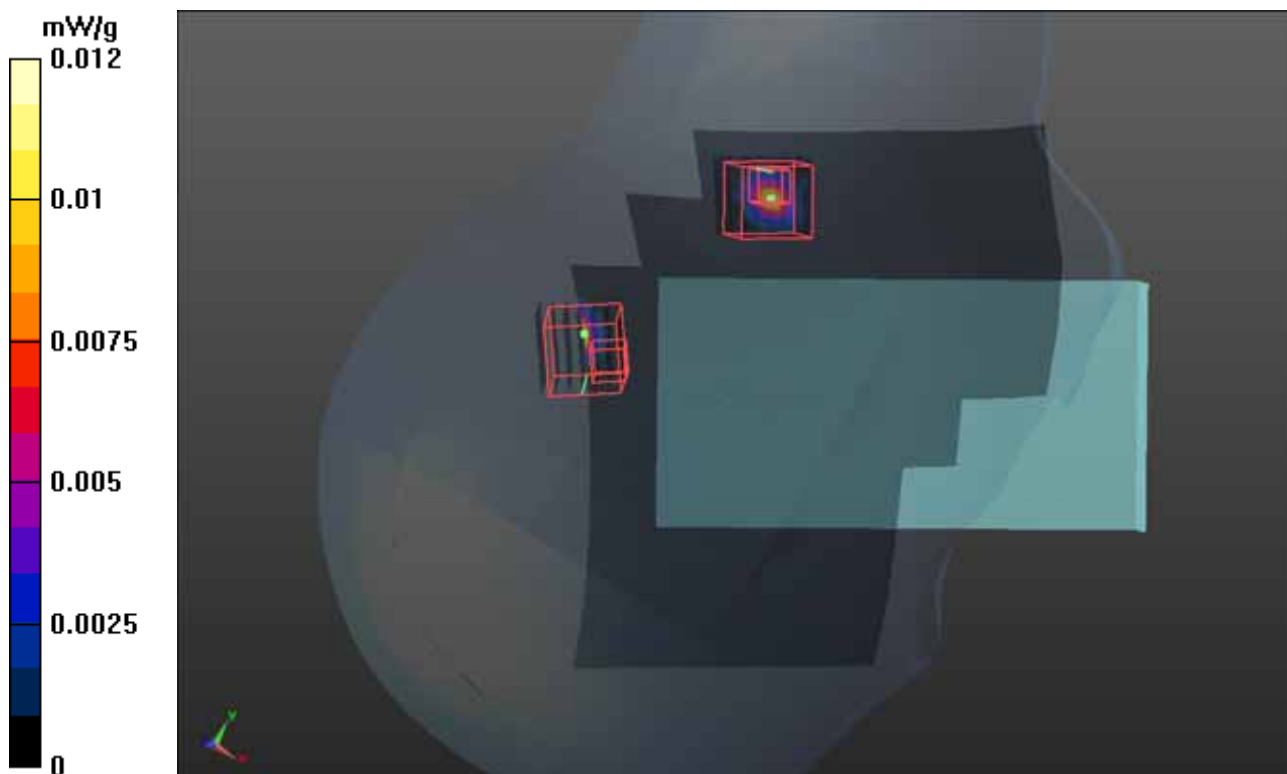

P42 802.11a_Left Cheek_Ch104_w MSR_Ant 0_w_o_Holstery

DUT: 120703C13

Communication System: WLAN_5G; Frequency: 5520 MHz; Duty Cycle: 1:1

Medium: H5G_0813 Medium parameters used: $f = 5520$ MHz; $\sigma = 5.074$ mho/m; $\epsilon_r = 36.299$; $\rho = 1000$ kg/m³

Ambient Temperature : 21.7 °C ; Liquid Temperature : 20.4 °C

DASY5 Configuration:

- Probe: EX3DV4 - SN3590; ConvF(5.13, 5.13, 5.13); Calibrated: 2012/02/23;
- Sensor-Surface: 2mm (Mechanical Surface Detection)
- Electronics: DAE3 Sn579; Calibrated: 2012/04/27
- Phantom: SAM with CRP v5.0 Front; Type: QD000P40CD; Serial: TP:1653
- Measurement SW: DASY52, Version 52.8 (1); SEMCAD X Version 14.6.5 (6469)

Ch104/Area Scan (161x181x1): Measurement grid: dx=10mm, dy=10mm

Maximum value of SAR (interpolated) = 0.0156 mW/g

Ch104/Zoom Scan (7x7x9)/Cube 0: Measurement grid: dx=4mm, dy=4mm, dz=2.5mm

Reference Value = 0 V/m; Power Drift = 0.00 dB

Peak SAR (extrapolated) = 0.223 mW/g

SAR(1 g) = 0.00109 mW/g; SAR(10 g) = 0.000111 mW/g

Maximum value of SAR (measured) = 0.223 mW/g

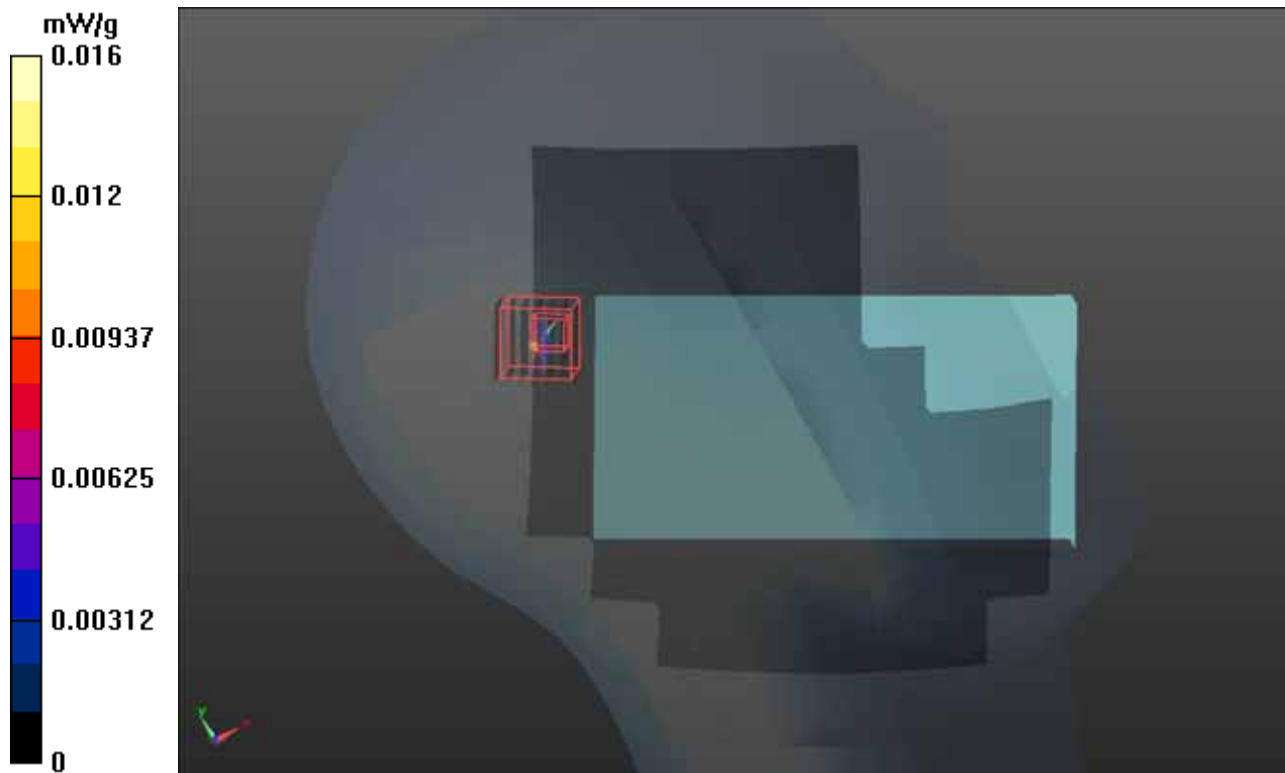

P43 802.11a_Left Tilted_Ch104_w MSR_Ant 0_w_o_Holstery

DUT: 120703C13

Communication System: WLAN_5G; Frequency: 5520 MHz; Duty Cycle: 1:1

Medium: H5G_0813 Medium parameters used: $f = 5520$ MHz; $\sigma = 5.074$ mho/m; $\epsilon_r = 36.299$; $\rho = 1000$ kg/m³

Ambient Temperature : 21.7 °C ; Liquid Temperature : 20.4 °C

DASY5 Configuration:

- Probe: EX3DV4 - SN3590; ConvF(5.13, 5.13, 5.13); Calibrated: 2012/02/23;
- Sensor-Surface: 2mm (Mechanical Surface Detection)
- Electronics: DAE3 Sn579; Calibrated: 2012/04/27
- Phantom: SAM with CRP v5.0 Front; Type: QD000P40CD; Serial: TP:1653
- Measurement SW: DASY52, Version 52.8 (1); SEMCAD X Version 14.6.5 (6469)

Ch104/Area Scan (161x181x1): Measurement grid: dx=10mm, dy=10mm

Maximum value of SAR (interpolated) = 0.847 mW/g

Ch104/Zoom Scan (7x7x9)/Cube 0: Measurement grid: dx=4mm, dy=4mm, dz=2.5mm

Reference Value = 0 V/m; Power Drift = 0.00 dB

Peak SAR (extrapolated) = 0.162 mW/g

SAR(1 g) = 0.00039 mW/g; SAR(10 g) = 1.88e-005 mW/g

Maximum value of SAR (measured) = 0.162 mW/g

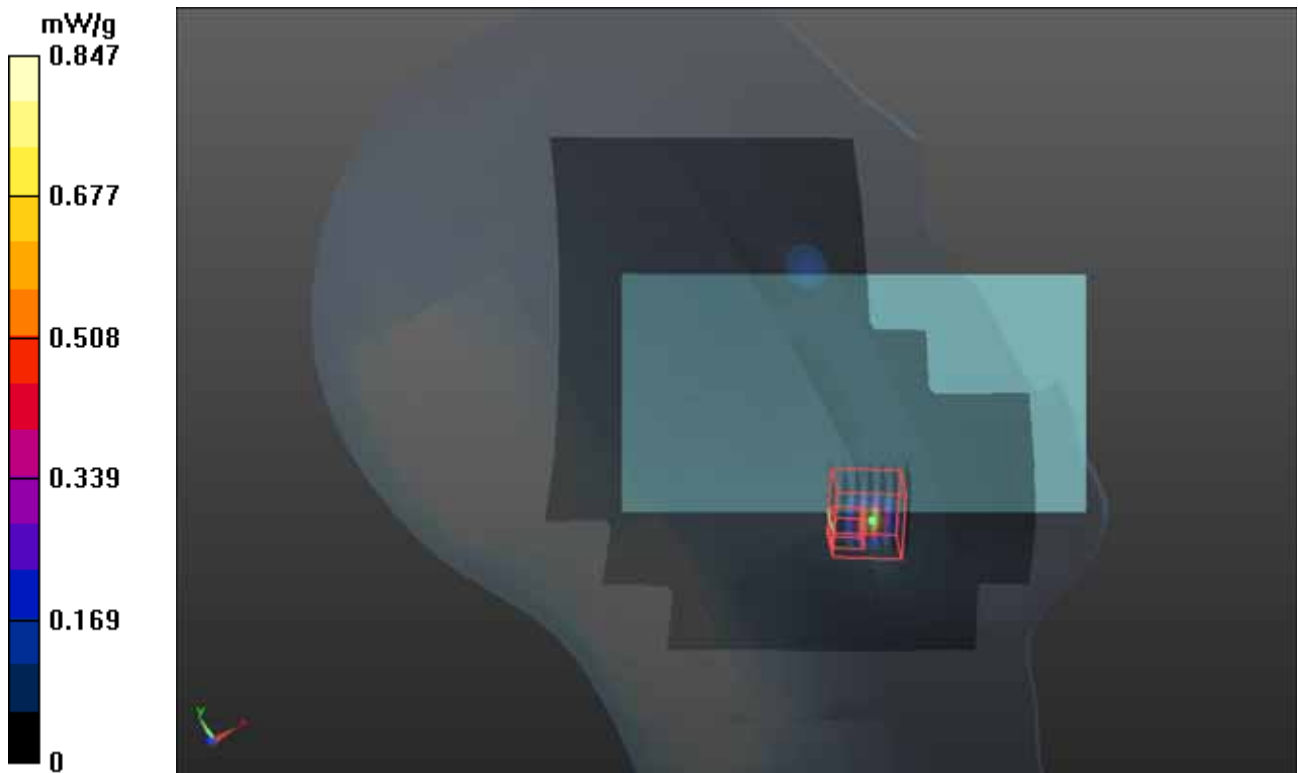

P46 802.11a_Right Cheek_Ch116_w_o MSR_Ant 1_w_o_Holstery

DUT: 120703C13

Communication System: WLAN_5G; Frequency: 5580 MHz; Duty Cycle: 1:1

Medium: H5G_0813 Medium parameters used: $f = 5580$ MHz; $\sigma = 5.148$ mho/m; $\epsilon_r = 36.136$; $\rho = 1000$ kg/m³

Ambient Temperature : 21.7 °C ; Liquid Temperature : 20.4 °C

DASY5 Configuration:

- Probe: EX3DV4 - SN3590; ConvF(4.89, 4.89, 4.89); Calibrated: 2012/02/23;
- Sensor-Surface: 2mm (Mechanical Surface Detection)
- Electronics: DAE3 Sn579; Calibrated: 2012/04/27
- Phantom: SAM with CRP v5.0 Front; Type: QD000P40CD; Serial: TP:1653
- Measurement SW: DASY52, Version 52.8 (1); SEMCAD X Version 14.6.5 (6469)

Ch116/Area Scan (161x181x1): Measurement grid: dx=10mm, dy=10mm

Maximum value of SAR (interpolated) = 0.0659 mW/g

Ch116/Zoom Scan (7x7x9)/Cube 1: Measurement grid: dx=4mm, dy=4mm, dz=2.5mm

Reference Value = 0 V/m; Power Drift = 0.00 dB

Peak SAR (extrapolated) = 0.275 mW/g

SAR(1 g) = 0.030 mW/g; SAR(10 g) = 0.00888 mW/g

Maximum value of SAR (measured) = 0.0689 mW/g

Ch116/Zoom Scan (7x7x9)/Cube 0: Measurement grid: dx=4mm, dy=4mm, dz=2.5mm

Reference Value = 0 V/m; Power Drift = 0.00 dB

Peak SAR (extrapolated) = 0.315 mW/g

SAR(1 g) = 0.00303 mW/g; SAR(10 g) = 0.000192 mW/g

Maximum value of SAR (measured) = 0.151 mW/g

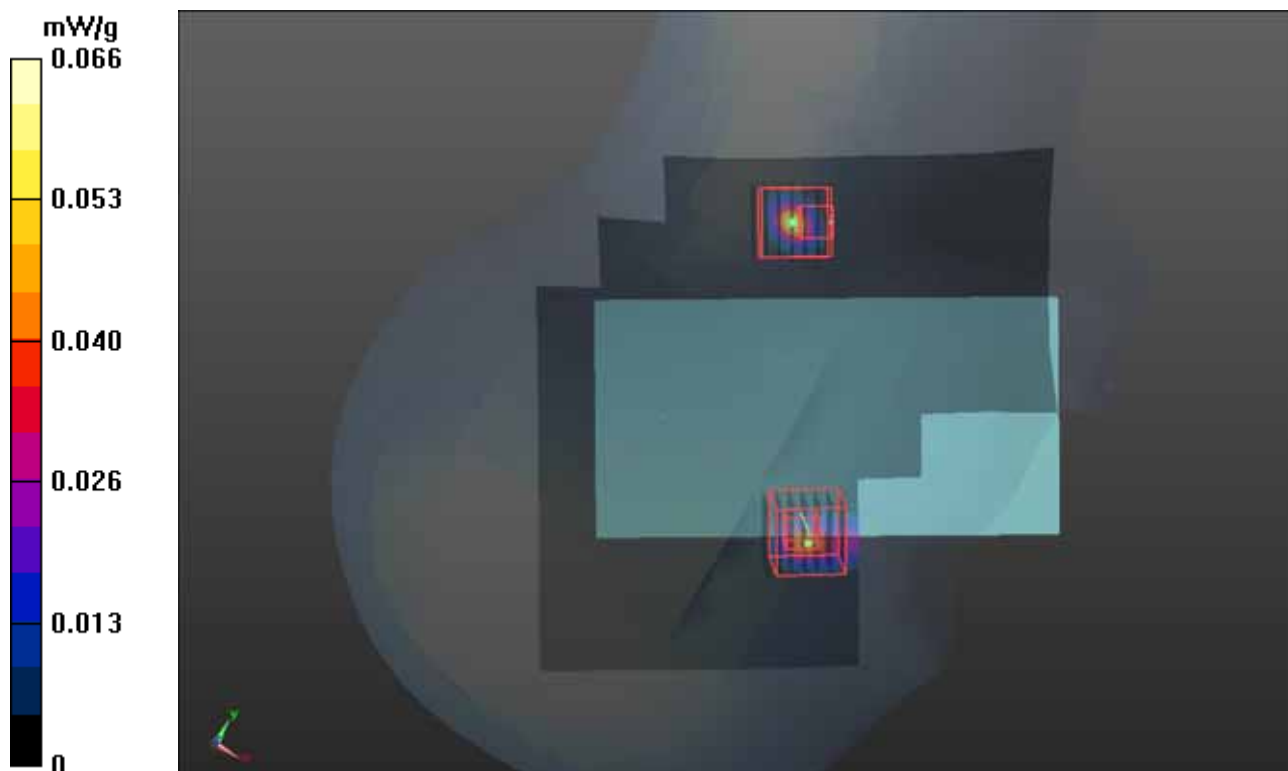

P47 802.11a_Right Cheek_Ch116_w MSR_Ant 1_w_o_Holstery

DUT: 120703C13

Communication System: WLAN_5G; Frequency: 5580 MHz; Duty Cycle: 1:1

Medium: H5G_0813 Medium parameters used: $f = 5580$ MHz; $\sigma = 5.148$ mho/m; $\epsilon_r = 36.136$; $\rho = 1000$ kg/m³

Ambient Temperature : 21.7 °C ; Liquid Temperature : 20.4 °C

DASY5 Configuration:

- Probe: EX3DV4 - SN3590; ConvF(4.89, 4.89, 4.89); Calibrated: 2012/02/23;
- Sensor-Surface: 2mm (Mechanical Surface Detection)
- Electronics: DAE3 Sn579; Calibrated: 2012/04/27
- Phantom: SAM with CRP v5.0 Front; Type: QD000P40CD; Serial: TP:1653
- Measurement SW: DASY52, Version 52.8 (1); SEMCAD X Version 14.6.5 (6469)

Ch116/Area Scan (161x181x1): Measurement grid: dx=10mm, dy=10mm

Maximum value of SAR (interpolated) = 0.148 mW/g

Ch116/Zoom Scan (7x7x9)/Cube 0: Measurement grid: dx=4mm, dy=4mm, dz=2.5mm

Reference Value = 0 V/m; Power Drift = 0.12 dB

Peak SAR (extrapolated) = 0.233 mW/g

SAR(1 g) = 0.045 mW/g; SAR(10 g) = 0.014 mW/g

Maximum value of SAR (measured) = 0.123 mW/g

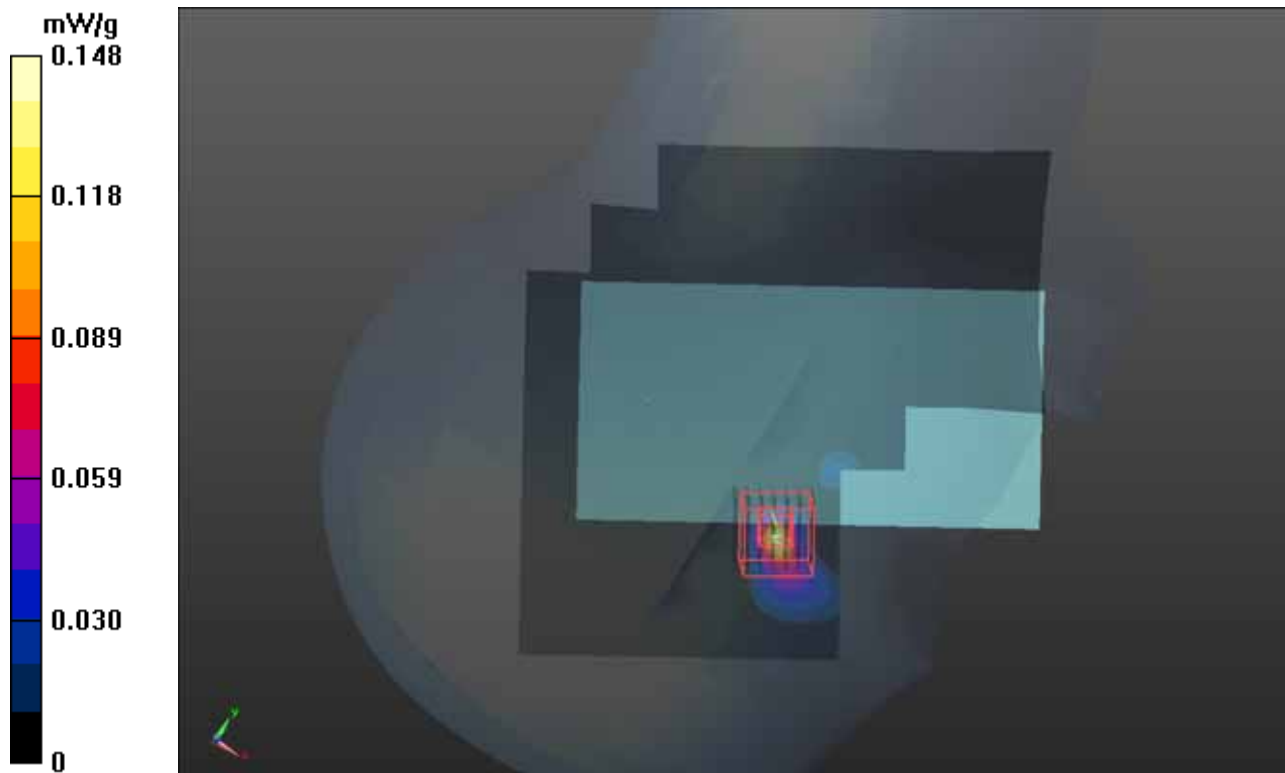

P48 802.11a_Right Tilted_Ch116_w MSR_Ant 1_w_o_Holstery

DUT: 120703C13

Communication System: WLAN_5G; Frequency: 5580 MHz; Duty Cycle: 1:1

Medium: H5G_0813 Medium parameters used: $f = 5580$ MHz; $\sigma = 5.148$ mho/m; $\epsilon_r = 36.136$; $\rho = 1000$ kg/m³

Ambient Temperature : 21.7 °C ; Liquid Temperature : 20.4 °C

DASY5 Configuration:

- Probe: EX3DV4 - SN3590; ConvF(4.89, 4.89, 4.89); Calibrated: 2012/02/23;
- Sensor-Surface: 2mm (Mechanical Surface Detection)
- Electronics: DAE3 Sn579; Calibrated: 2012/04/27
- Phantom: SAM with CRP v5.0 Front; Type: QD000P40CD; Serial: TP:1653
- Measurement SW: DASY52, Version 52.8 (1); SEMCAD X Version 14.6.5 (6469)

Ch116/Area Scan (161x181x1): Measurement grid: dx=10mm, dy=10mm

Maximum value of SAR (interpolated) = 0.00254 mW/g

Ch116/Zoom Scan (7x7x9)/Cube 0: Measurement grid: dx=4mm, dy=4mm, dz=2.5mm

Reference Value = 0 V/m; Power Drift = 0.101 dB

Peak SAR (extrapolated) = 0.00378 mW/g

SAR(1 g) = 1.87e-005 mW/g; SAR(10 g) = 1.9e-006 mW/g

Maximum value of SAR (measured) = 0.0876 mW/g

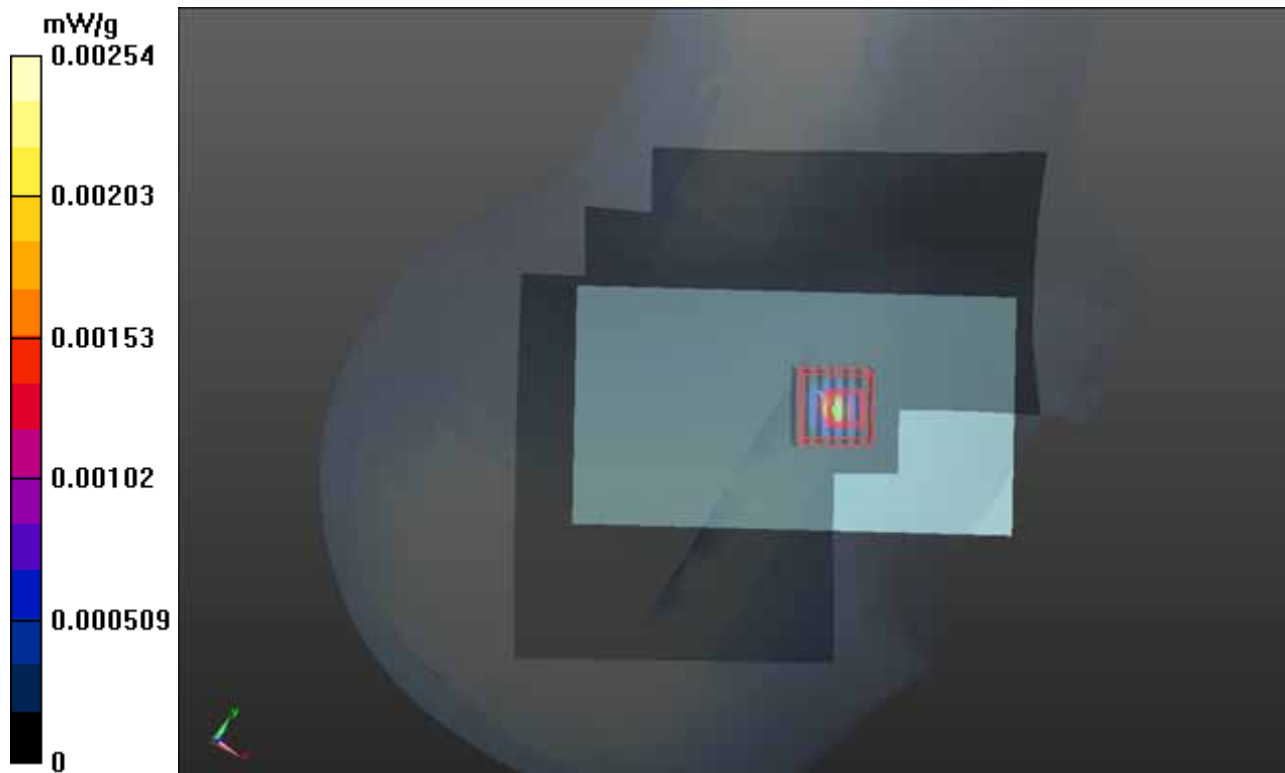

P49 802.11a_Left Cheek_Ch116_w MSR_Ant 1_w_o_Holstery

DUT: 120703C13

Communication System: WLAN_5G; Frequency: 5580 MHz; Duty Cycle: 1:1

Medium: H5G_0813 Medium parameters used: $f = 5580$ MHz; $\sigma = 5.148$ mho/m; $\epsilon_r = 36.136$; $\rho = 1000$ kg/m³

Ambient Temperature : 21.7 °C ; Liquid Temperature : 20.4 °C

DASY5 Configuration:

- Probe: EX3DV4 - SN3590; ConvF(4.89, 4.89, 4.89); Calibrated: 2012/02/23;
- Sensor-Surface: 2mm (Mechanical Surface Detection)
- Electronics: DAE3 Sn579; Calibrated: 2012/04/27
- Phantom: SAM with CRP v5.0 Front; Type: QD000P40CD; Serial: TP:1653
- Measurement SW: DASY52, Version 52.8 (1); SEMCAD X Version 14.6.5 (6469)

Ch116/Area Scan (161x181x1): Measurement grid: dx=10mm, dy=10mm

Maximum value of SAR (interpolated) = 0.185 mW/g

Ch116/Zoom Scan (7x7x9)/Cube 1: Measurement grid: dx=4mm, dy=4mm, dz=2.5mm

Reference Value = 0.888 V/m; Power Drift = 0.14 dB

Peak SAR (extrapolated) = 0.236 mW/g

SAR(1 g) = 0.0033 mW/g; SAR(10 g) = 0.000366 mW/g

Maximum value of SAR (measured) = 0.118 mW/g

Ch116/Zoom Scan (7x7x9)/Cube 0: Measurement grid: dx=4mm, dy=4mm, dz=2.5mm

Reference Value = 0.888 V/m; Power Drift = 0.14 dB

Peak SAR (extrapolated) = 0 mW/g

SAR(1 g) = n.a. ; SAR(10 g) = n.a.

Maximum value of SAR (measured) = 0.0878 mW/g

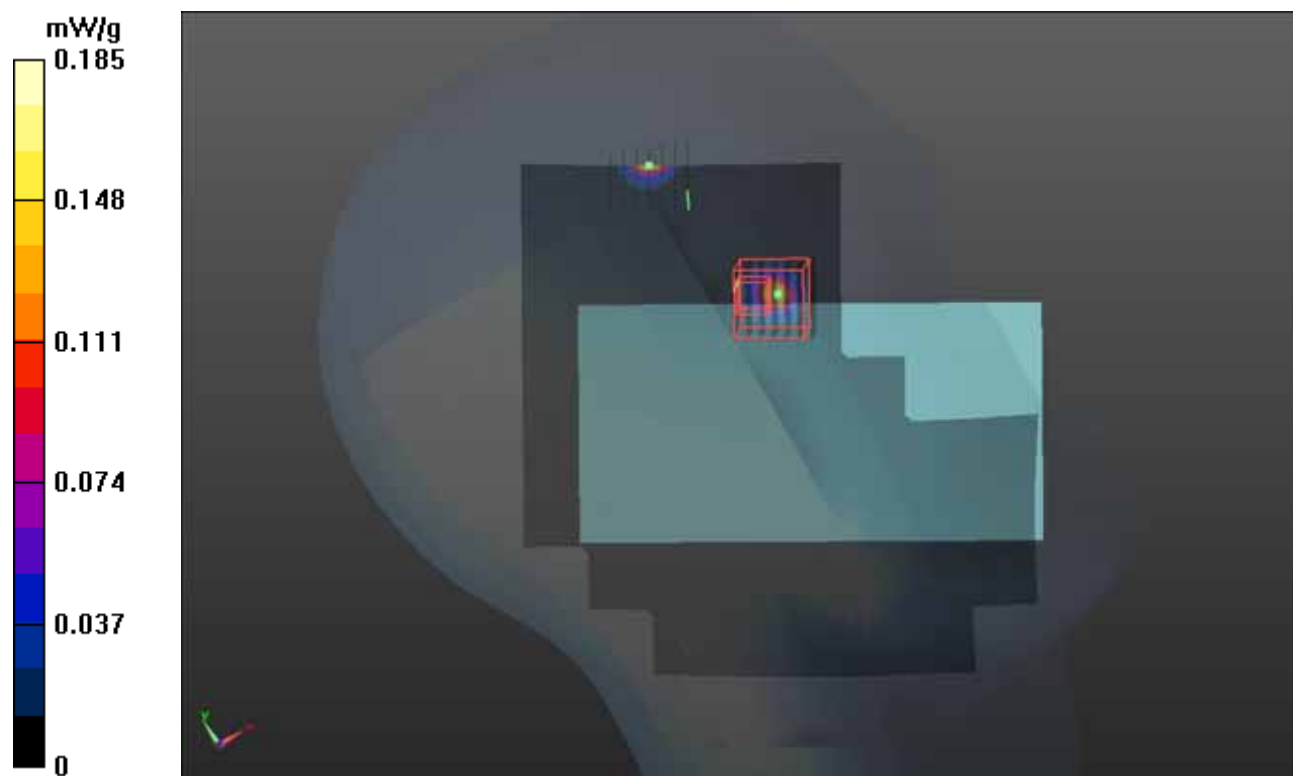

P50 802.11a_Left Tilted_Ch116_w MSR_Ant 1_w_o_Holstery

DUT: 120703C13

Communication System: WLAN_5G; Frequency: 5580 MHz; Duty Cycle: 1:1

Medium: H5G_0813 Medium parameters used: $f = 5580$ MHz; $\sigma = 5.148$ mho/m; $\epsilon_r = 36.136$; $\rho = 1000$ kg/m³

Ambient Temperature : 21.7 °C ; Liquid Temperature : 20.4 °C

DASY5 Configuration:

- Probe: EX3DV4 - SN3590; ConvF(4.89, 4.89, 4.89); Calibrated: 2012/02/23;
- Sensor-Surface: 2mm (Mechanical Surface Detection)
- Electronics: DAE3 Sn579; Calibrated: 2012/04/27
- Phantom: SAM with CRP v5.0 Front; Type: QD000P40CD; Serial: TP:1653
- Measurement SW: DASY52, Version 52.8 (1); SEMCAD X Version 14.6.5 (6469)

Ch116/Area Scan (161x181x1): Measurement grid: dx=10mm, dy=10mm

Maximum value of SAR (interpolated) = 0.125 mW/g

Ch116/Zoom Scan (7x7x9)/Cube 0: Measurement grid: dx=4mm, dy=4mm, dz=2.5mm

Reference Value = 0.798 V/m; Power Drift = -0.13 dB

Peak SAR (extrapolated) = 0.015 mW/g

SAR(1 g) = 0.000411 mW/g; SAR(10 g) = 4.12e-005 mW/g

Maximum value of SAR (measured) = 0.149 mW/g

Ch116/Zoom Scan (7x7x9)/Cube 1: Measurement grid: dx=4mm, dy=4mm, dz=2.5mm

Reference Value = 0.798 V/m; Power Drift = -0.13 dB

Peak SAR (extrapolated) = 0.00271 mW/g

SAR(1 g) = 4.34e-005 mW/g; SAR(10 g) = 4.33e-006 mW/g

Maximum value of SAR (measured) = 0.0482 mW/g

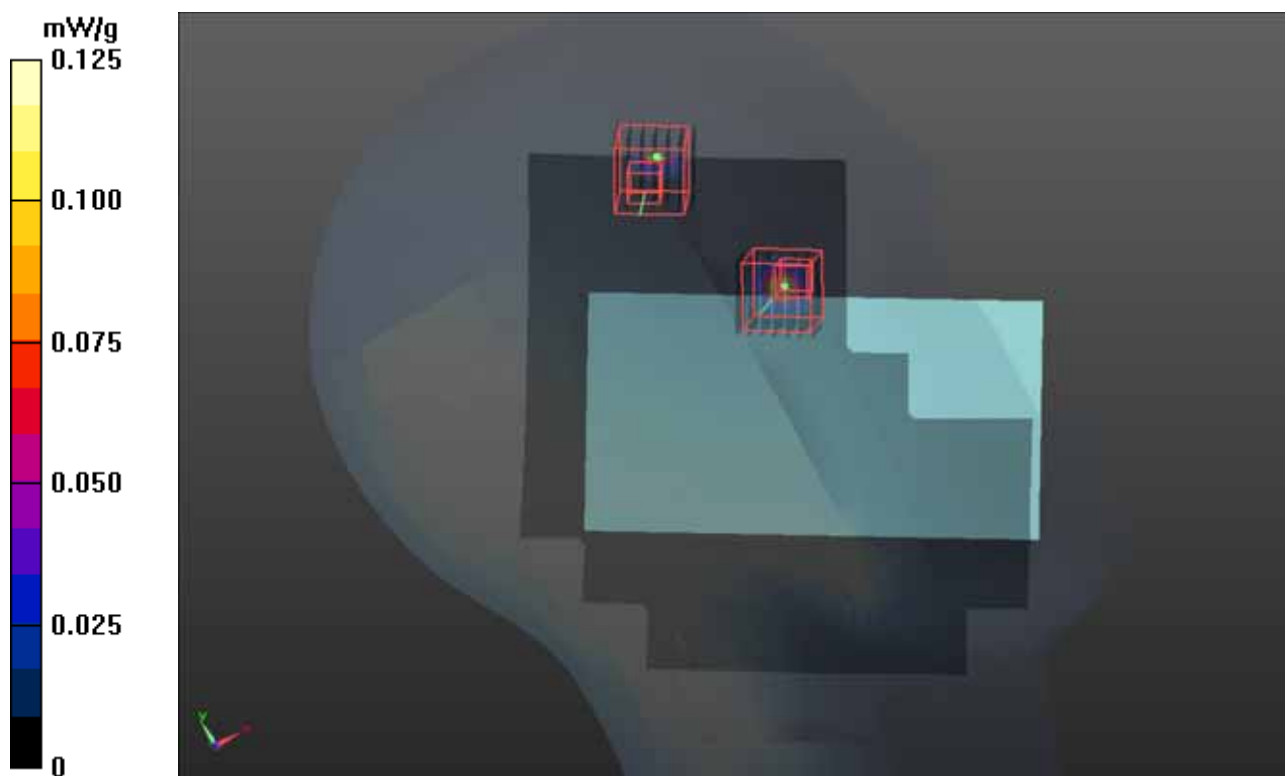

P53 802.11a_Right Cheek_Ch149_w_o MSR_Ant 0_w_o_Holstery

DUT: 120703C13

Communication System: WLAN_5G; Frequency: 5745 MHz; Duty Cycle: 1:1

Medium: H5G_0814 Medium parameters used: $f = 5745$ MHz; $\sigma = 5.352$ mho/m; $\epsilon_r = 35.824$; $\rho = 1000$ kg/m³

Ambient Temperature : 21.7 °C ; Liquid Temperature : 20.2 °C

DASY5 Configuration:

- Probe: EX3DV4 - SN3590; ConvF(4.79, 4.79, 4.79); Calibrated: 2012/02/23;
- Sensor-Surface: 2mm (Mechanical Surface Detection)
- Electronics: DAE3 Sn579; Calibrated: 2012/04/27
- Phantom: SAM with CRP v5.0 Front; Type: QD000P40CD; Serial: TP:1653
- Measurement SW: DASY52, Version 52.8 (1); SEMCAD X Version 14.6.5 (6469)

Ch149/Area Scan (161x181x1): Measurement grid: dx=10mm, dy=10mm

Maximum value of SAR (interpolated) = 0.0316 mW/g

Ch149/Zoom Scan (7x7x9)/Cube 0: Measurement grid: dx=4mm, dy=4mm, dz=2.5mm

Reference Value = 0 V/m; Power Drift = 0.10 dB

Peak SAR (extrapolated) = 0.219 mW/g

SAR(1 g) = 0.00208 mW/g; SAR(10 g) = 0.000131 mW/g

Maximum value of SAR (measured) = 0.105 mW/g

Ch149/Zoom Scan (7x7x9)/Cube 1: Measurement grid: dx=4mm, dy=4mm, dz=2.5mm

Reference Value = 0 V/m; Power Drift = 0.10 dB

Peak SAR (extrapolated) = 0.149 mW/g

SAR(1 g) = 0.00153 mW/g; SAR(10 g) = 9.79e-005 mW/g

Maximum value of SAR (measured) = 0.0730 mW/g

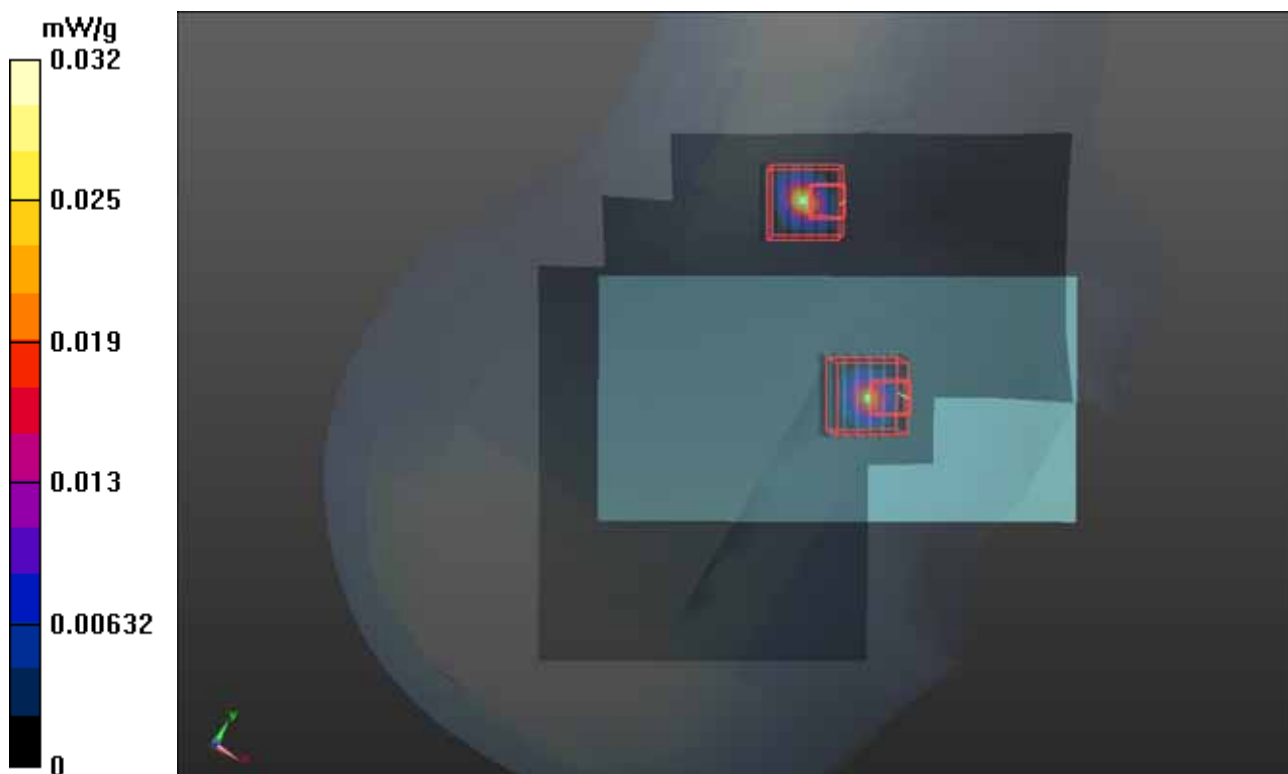

P54 802.11a_Right Cheek_Ch157_w MSR_Ant 0_w_o_Holstery

DUT: 120703C13

Communication System: WLAN_5G; Frequency: 5785 MHz; Duty Cycle: 1:1

Medium: H5G_0814 Medium parameters used: $f = 5785$ MHz; $\sigma = 5.391$ mho/m; $\epsilon_r = 35.714$; $\rho = 1000$ kg/m³

Ambient Temperature : 21.7 °C ; Liquid Temperature : 20.2 °C

DASY5 Configuration:

- Probe: EX3DV4 - SN3590; ConvF(4.79, 4.79, 4.79); Calibrated: 2012/02/23;
- Sensor-Surface: 2mm (Mechanical Surface Detection)
- Electronics: DAE3 Sn579; Calibrated: 2012/04/27
- Phantom: SAM with CRP v5.0 Front; Type: QD000P40CD; Serial: TP:1653
- Measurement SW: DASY52, Version 52.8 (1); SEMCAD X Version 14.6.5 (6469)

Ch157/Area Scan (161x181x1): Measurement grid: dx=10mm, dy=10mm

Maximum value of SAR (interpolated) = 0.00166 mW/g

Ch157/Zoom Scan (7x7x9)/Cube 0: Measurement grid: dx=4mm, dy=4mm, dz=2.5mm

Reference Value = 0.507 V/m; Power Drift = 0.19 dB

Peak SAR (extrapolated) = 0.019 mW/g

SAR(1 g) = 0.000762 mW/g; SAR(10 g) = 8.37e-005 mW/g

Maximum value of SAR (measured) = 0.0191 mW/g

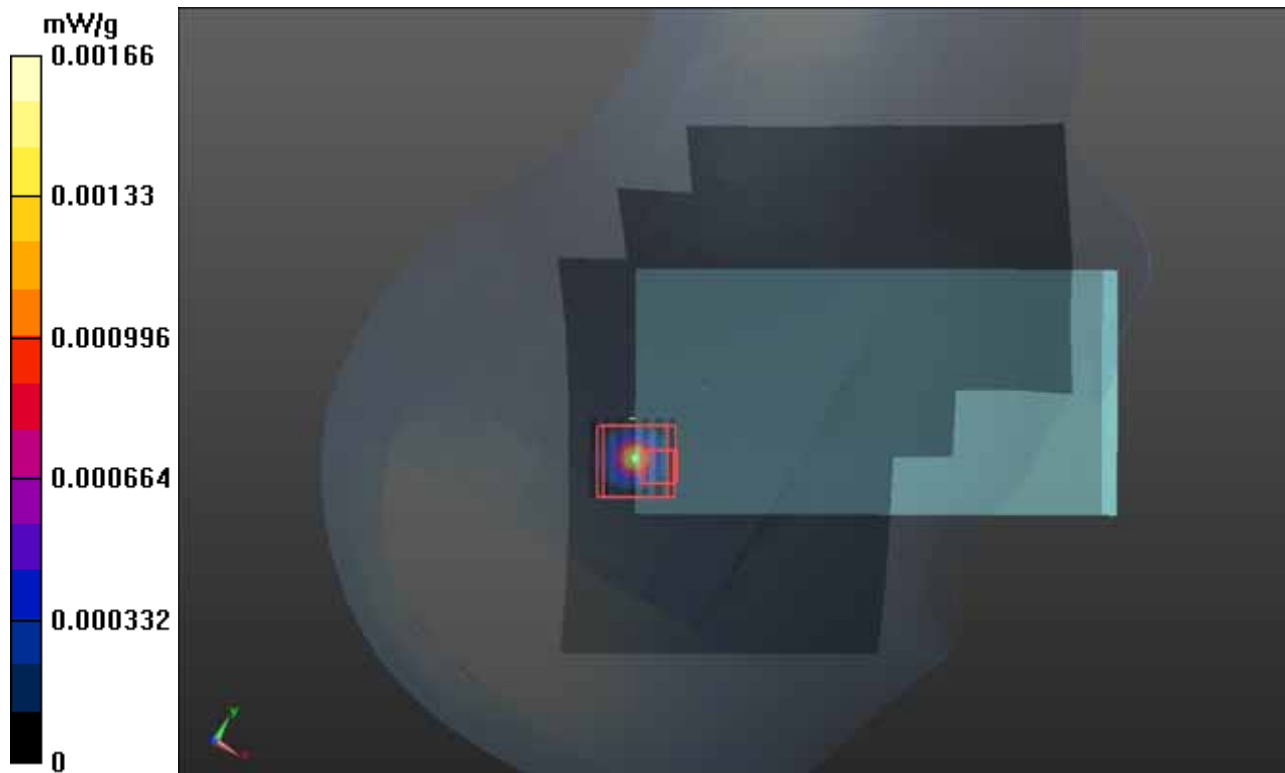

P55 802.11a_Right Tilted_Ch149_w_o MSR_Ant 0_w_o_Holstery

DUT: 120703C13

Communication System: WLAN_5G; Frequency: 5745 MHz; Duty Cycle: 1:1

Medium: H5G_0814 Medium parameters used: $f = 5745$ MHz; $\sigma = 5.352$ mho/m; $\epsilon_r = 35.824$; $\rho = 1000$ kg/m³

Ambient Temperature : 21.7 °C ; Liquid Temperature : 20.2 °C

DASY5 Configuration:

- Probe: EX3DV4 - SN3590; ConvF(4.79, 4.79, 4.79); Calibrated: 2012/02/23;
- Sensor-Surface: 2mm (Mechanical Surface Detection)
- Electronics: DAE3 Sn579; Calibrated: 2012/04/27
- Phantom: SAM with CRP v5.0 Front; Type: QD000P40CD; Serial: TP:1653
- Measurement SW: DASY52, Version 52.8 (1); SEMCAD X Version 14.6.5 (6469)

Ch149/Area Scan (161x181x1): Measurement grid: dx=10mm, dy=10mm

Maximum value of SAR (interpolated) = 0.0776 mW/g

Ch149/Zoom Scan (7x7x9)/Cube 0: Measurement grid: dx=4mm, dy=4mm, dz=2.5mm

Reference Value = 0 V/m; Power Drift = 0.05 dB

Peak SAR (extrapolated) = 0.00175 mW/g

SAR(1 g) = 4.06e-006 mW/g; SAR(10 g) = 1.93e-007 mW/g

Maximum value of SAR (measured) = 0.0233 mW/g

Ch149/Zoom Scan (7x7x9)/Cube 1: Measurement grid: dx=4mm, dy=4mm, dz=2.5mm

Reference Value = 0 V/m; Power Drift = 0.05 dB

Peak SAR (extrapolated) = 0.024 mW/g

SAR(1 g) = n.a. ; SAR(10 g) = n.a.

Maximum value of SAR (measured) = 0.0244 mW/g

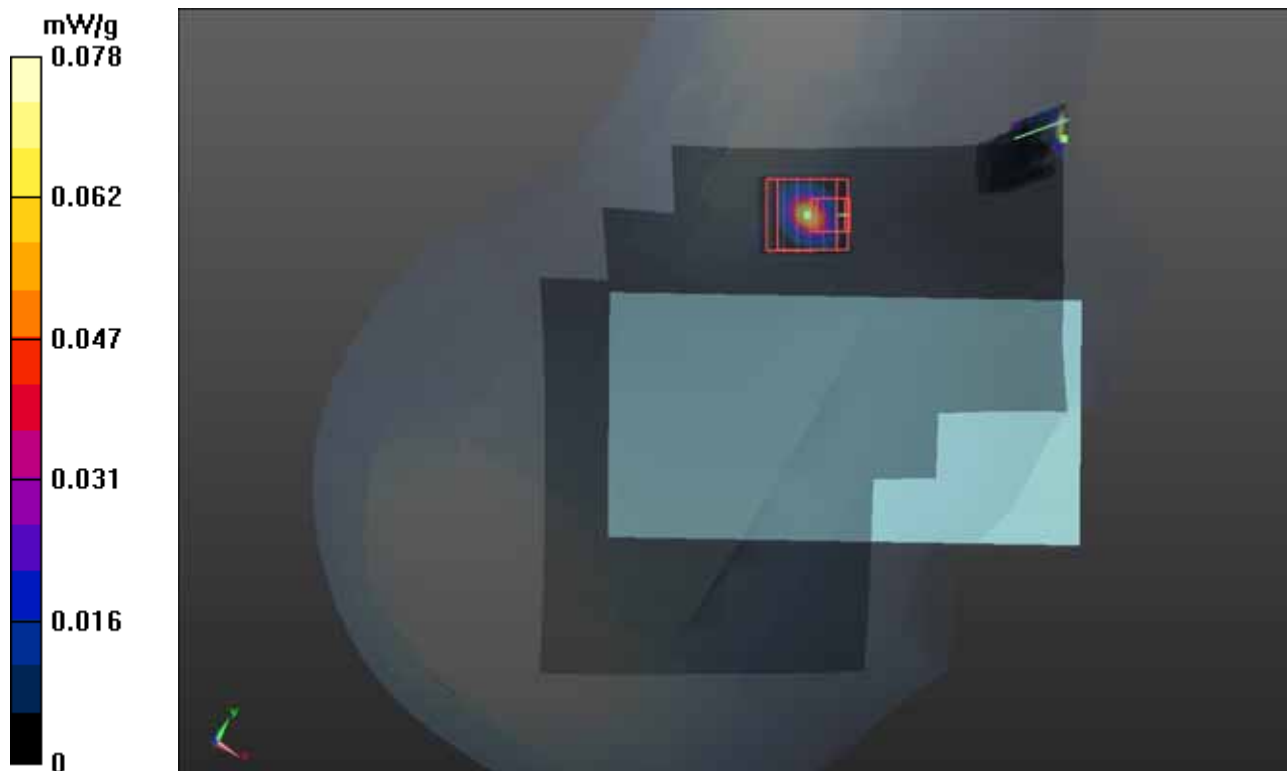

P56 802.11a_Left Cheek_Ch149_w_o MSR_Ant 0_w_o_Holstery

DUT: 120703C13

Communication System: WLAN_5G; Frequency: 5745 MHz; Duty Cycle: 1:1

Medium: H5G_0814 Medium parameters used: $f = 5745$ MHz; $\sigma = 5.352$ mho/m; $\epsilon_r = 35.824$; $\rho = 1000$ kg/m³

Ambient Temperature : 21.7 °C ; Liquid Temperature : 20.2 °C

DASY5 Configuration:

- Probe: EX3DV4 - SN3590; ConvF(4.79, 4.79, 4.79); Calibrated: 2012/02/23;
- Sensor-Surface: 2mm (Mechanical Surface Detection)
- Electronics: DAE3 Sn579; Calibrated: 2012/04/27
- Phantom: SAM with CRP v5.0 Front; Type: QD000P40CD; Serial: TP:1653
- Measurement SW: DASY52, Version 52.8 (1); SEMCAD X Version 14.6.5 (6469)

Ch149/Area Scan (161x181x1): Measurement grid: dx=10mm, dy=10mm

Maximum value of SAR (interpolated) = 0.187 mW/g

Ch149/Zoom Scan (7x7x9)/Cube 0: Measurement grid: dx=4mm, dy=4mm, dz=2.5mm

Reference Value = 0 V/m; Power Drift = 0.08 dB

Peak SAR (extrapolated) = 0.027 mW/g

SAR(1 g) = 4.09e-005 mW/g; SAR(10 g) = 1.01e-006 mW/g

Maximum value of SAR (measured) = 0.0836 mW/g

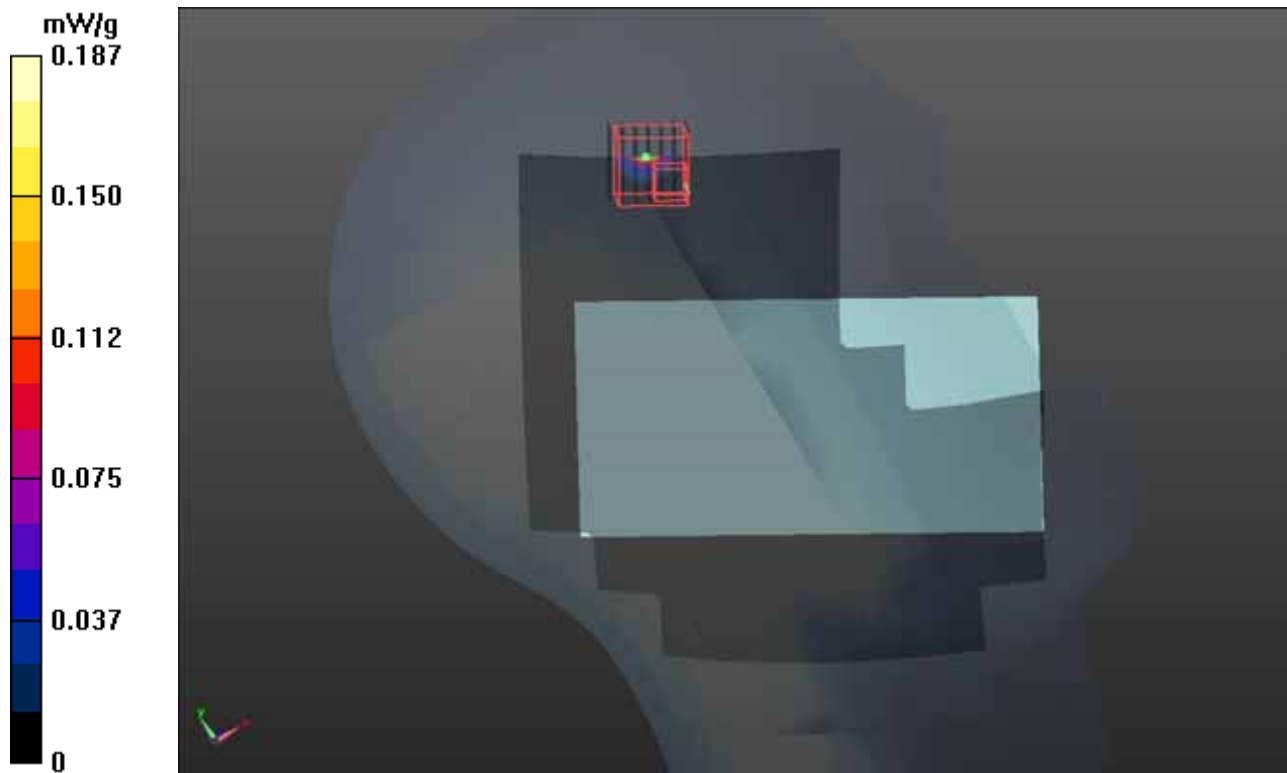

P57 802.11a_Left Tilted_Ch149_w_o MSR_Ant 0_w_o_Holstery

DUT: 120703C13

Communication System: WLAN_5G; Frequency: 5745 MHz; Duty Cycle: 1:1

Medium: H5G_0814 Medium parameters used: $f = 5745$ MHz; $\sigma = 5.352$ mho/m; $\epsilon_r = 35.824$; $\rho = 1000$ kg/m³

Ambient Temperature : 21.7 °C ; Liquid Temperature : 20.2 °C

DASY5 Configuration:

- Probe: EX3DV4 - SN3590; ConvF(4.79, 4.79, 4.79); Calibrated: 2012/02/23;
- Sensor-Surface: 2mm (Mechanical Surface Detection)
- Electronics: DAE3 Sn579; Calibrated: 2012/04/27
- Phantom: SAM with CRP v5.0 Front; Type: QD000P40CD; Serial: TP:1653
- Measurement SW: DASY52, Version 52.8 (1); SEMCAD X Version 14.6.5 (6469)

Ch149/Area Scan (161x181x1): Measurement grid: dx=10mm, dy=10mm

Maximum value of SAR (interpolated) = 0.000351 mW/g

Ch149/Zoom Scan (7x7x9)/Cube 0: Measurement grid: dx=4mm, dy=4mm, dz=2.5mm

Reference Value = 0 V/m; Power Drift = 0.01 dB

Peak SAR (extrapolated) = 0.253 mW/g

SAR(1 g) = 0.00118 mW/g; SAR(10 g) = n.a.

Maximum value of SAR (measured) = 0.253 mW/g



P60 802.11n_HT20_Right Cheek_Ch149_w_o MSR_Ant 1_w_o_Holstery

DUT: 120703C13

Communication System: WLAN_5G; Frequency: 5745 MHz; Duty Cycle: 1:1

Medium: H5G_0814 Medium parameters used: $f = 5745$ MHz; $\sigma = 5.352$ mho/m; $\epsilon_r = 35.824$; $\rho = 1000$ kg/m³

Ambient Temperature : 21.7 °C ; Liquid Temperature : 20.2 °C

DASY5 Configuration:

- Probe: EX3DV4 - SN3590; ConvF(4.79, 4.79, 4.79); Calibrated: 2012/02/23;
- Sensor-Surface: 2mm (Mechanical Surface Detection)
- Electronics: DAE3 Sn579; Calibrated: 2012/04/27
- Phantom: SAM with CRP v5.0 Front; Type: QD000P40CD; Serial: TP:1653
- Measurement SW: DASY52, Version 52.8 (1); SEMCAD X Version 14.6.5 (6469)

Ch149/Area Scan (161x181x1): Measurement grid: dx=10mm, dy=10mm

Maximum value of SAR (interpolated) = 0.248 mW/g

Ch149/Zoom Scan (7x7x9)/Cube 0: Measurement grid: dx=4mm, dy=4mm, dz=2.5mm

Reference Value = 0 V/m; Power Drift = 0.05 dB

Peak SAR (extrapolated) = 0.437 mW/g

SAR(1 g) = 0.092 mW/g; SAR(10 g) = 0.028 mW/g

Maximum value of SAR (measured) = 0.234 mW/g

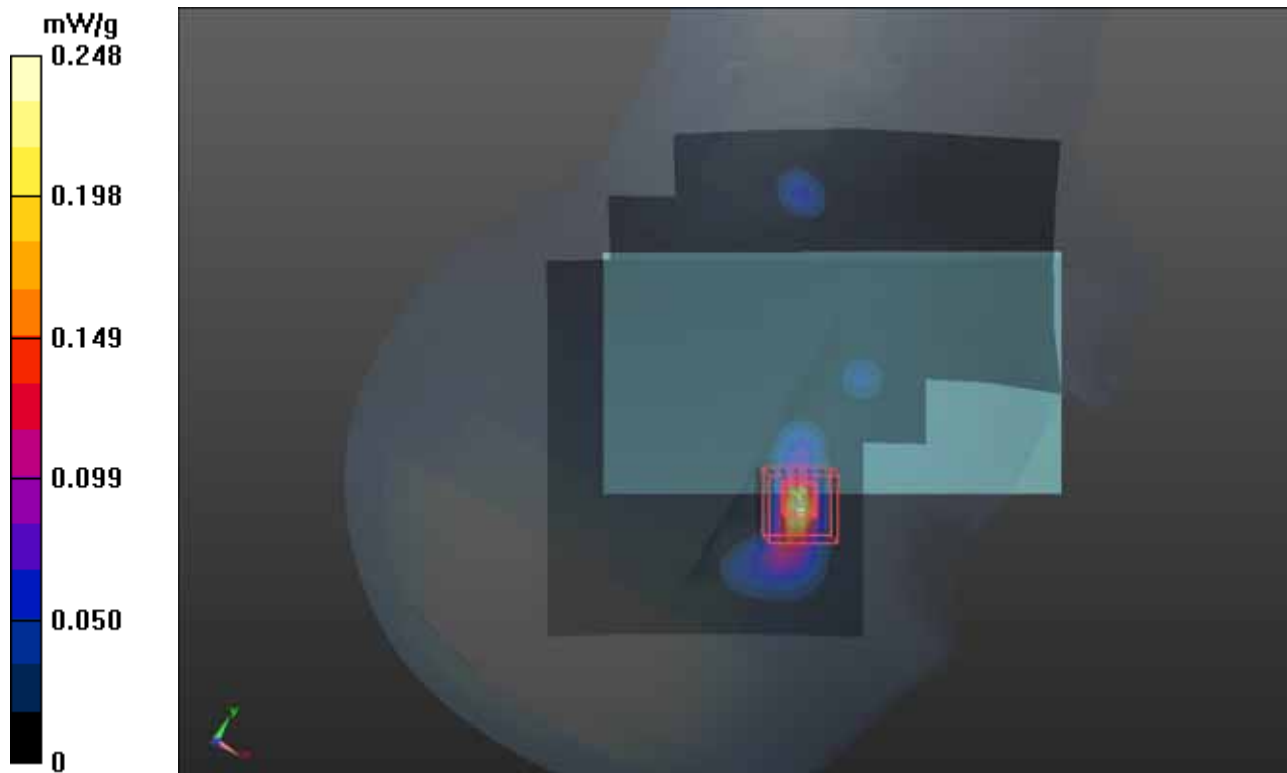

P61 802.11n_HT20_Right Cheek_Ch149_w MSR_Ant 1_w_o_Holstery

DUT: 120703C13

Communication System: WLAN_5G; Frequency: 5745 MHz; Duty Cycle: 1:1

Medium: H5G_0814 Medium parameters used: $f = 5745$ MHz; $\sigma = 5.352$ mho/m; $\epsilon_r = 35.824$; $\rho = 1000$ kg/m³

Ambient Temperature : 21.7 °C ; Liquid Temperature : 20.2 °C

DASY5 Configuration:

- Probe: EX3DV4 - SN3590; ConvF(4.79, 4.79, 4.79); Calibrated: 2012/02/23;
- Sensor-Surface: 2mm (Mechanical Surface Detection)
- Electronics: DAE3 Sn579; Calibrated: 2012/04/27
- Phantom: SAM with CRP v5.0 Front; Type: QD000P40CD; Serial: TP:1653
- Measurement SW: DASY52, Version 52.8 (1); SEMCAD X Version 14.6.5 (6469)

Ch149/Area Scan (161x181x1): Measurement grid: dx=10mm, dy=10mm

Maximum value of SAR (interpolated) = 0.388 mW/g

Ch149/Zoom Scan (7x7x9)/Cube 0: Measurement grid: dx=4mm, dy=4mm, dz=2.5mm

Reference Value = 0 V/m; Power Drift = 0.01 dB

Peak SAR (extrapolated) = 0.655 mW/g

SAR(1 g) = 0.147 mW/g; SAR(10 g) = 0.045 mW/g

Maximum value of SAR (measured) = 0.339 mW/g

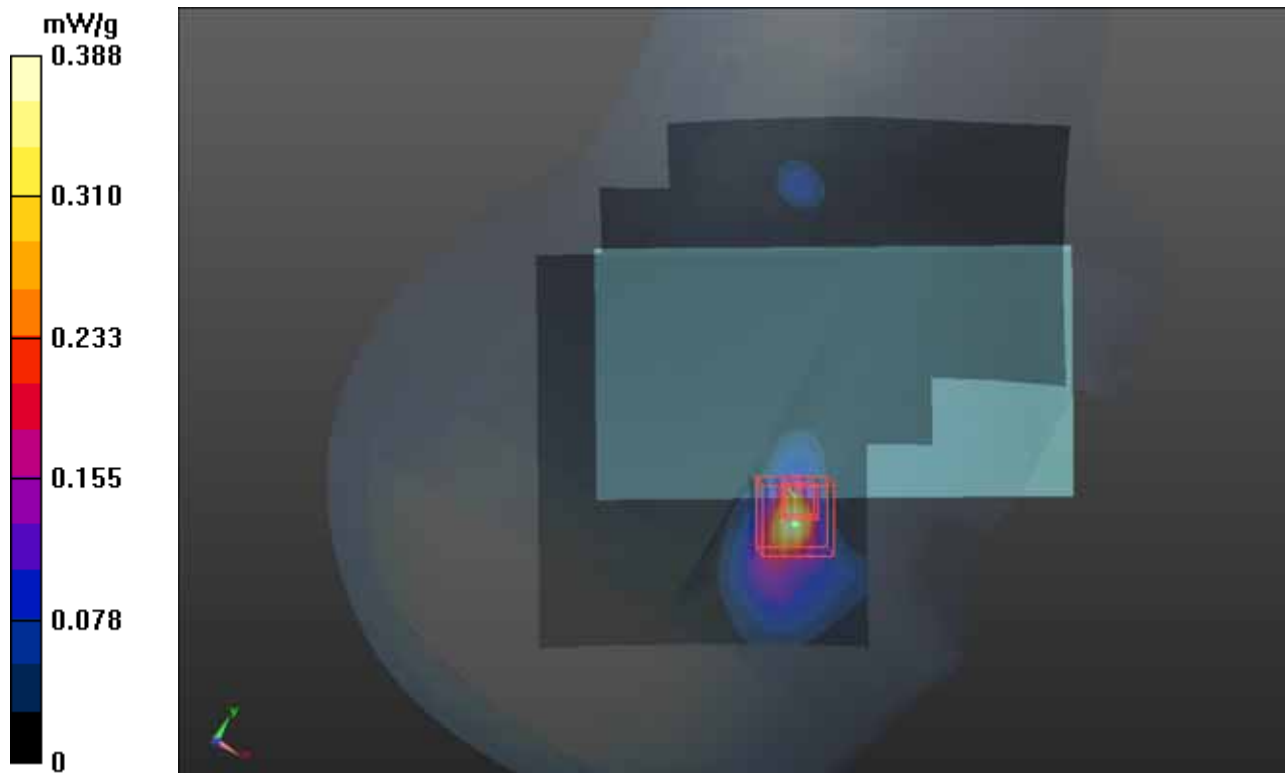

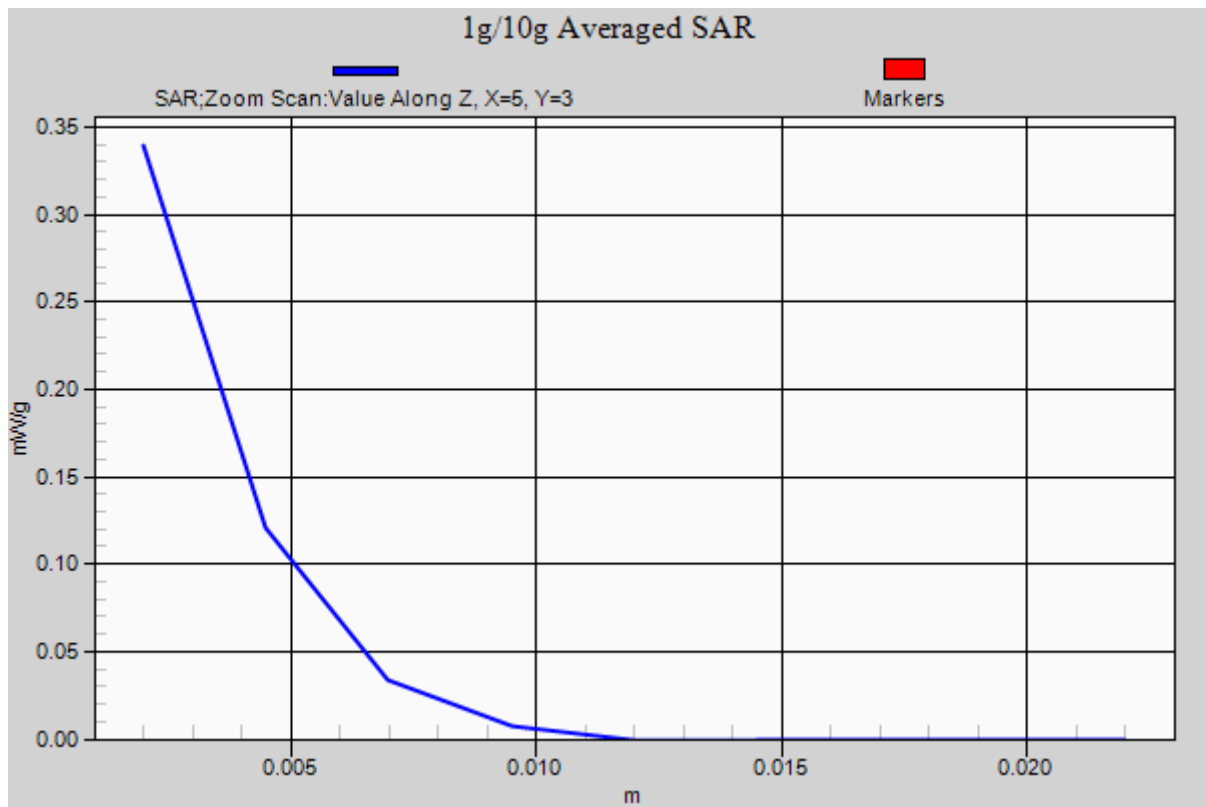

P62 802.11n_HT20_Right Tilted_Ch149_w MSR_Ant 1_w_o_Holstery

DUT: 120703C13

Communication System: WLAN_5G; Frequency: 5745 MHz; Duty Cycle: 1:1

Medium: H5G_0814 Medium parameters used: $f = 5745$ MHz; $\sigma = 5.352$ mho/m; $\epsilon_r = 35.824$; $\rho = 1000$ kg/m³

Ambient Temperature : 21.7 °C ; Liquid Temperature : 20.2 °C

DASY5 Configuration:

- Probe: EX3DV4 - SN3590; ConvF(4.79, 4.79, 4.79); Calibrated: 2012/02/23;
- Sensor-Surface: 2mm (Mechanical Surface Detection)
- Electronics: DAE3 Sn579; Calibrated: 2012/04/27
- Phantom: SAM with CRP v5.0 Front; Type: QD000P40CD; Serial: TP:1653
- Measurement SW: DASY52, Version 52.8 (1); SEMCAD X Version 14.6.5 (6469)

Ch149/Area Scan (161x181x1): Measurement grid: dx=10mm, dy=10mm

Maximum value of SAR (interpolated) = 0.206 mW/g

Ch149/Zoom Scan (7x7x9)/Cube 0: Measurement grid: dx=4mm, dy=4mm, dz=2.5mm

Reference Value = 0 V/m; Power Drift = 0.07 dB

Peak SAR (extrapolated) = 0.284 mW/g

SAR(1 g) = 0.033 mW/g; SAR(10 g) = 0.013 mW/g

Maximum value of SAR (measured) = 0.0725 mW/g

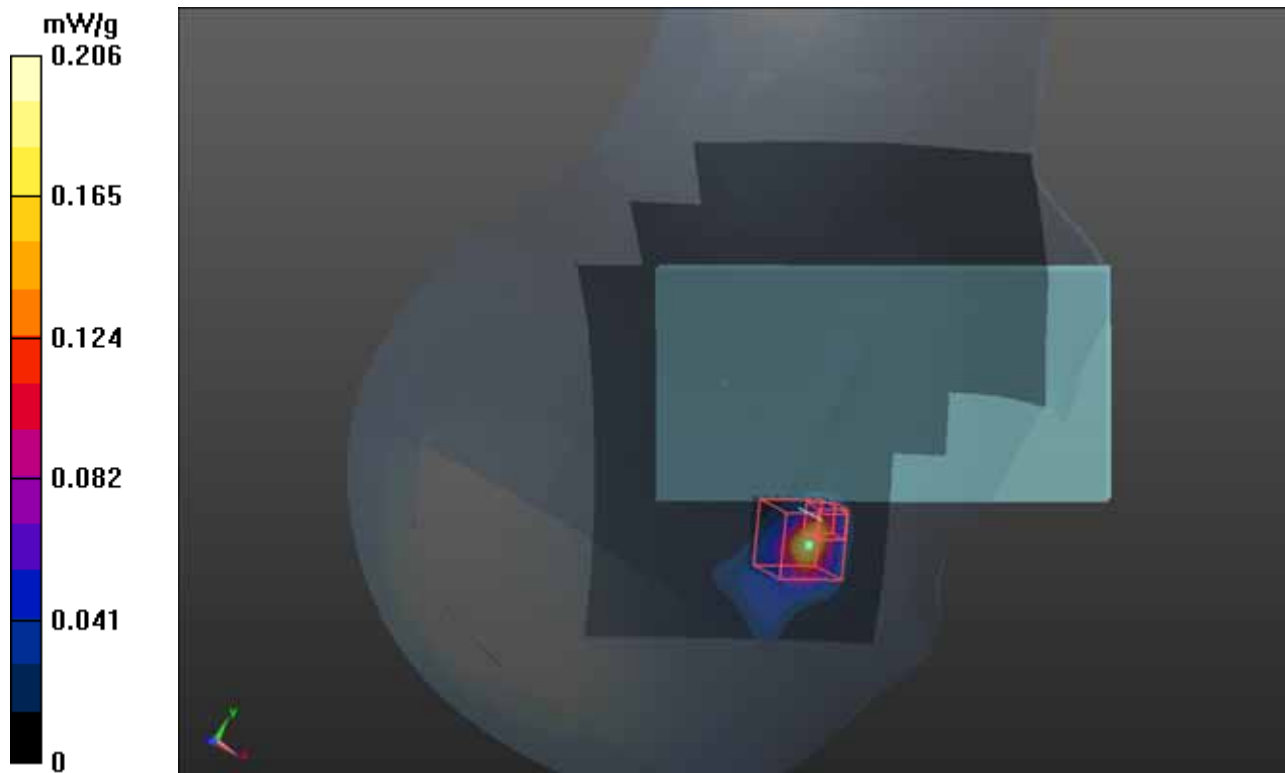

P63 802.11n_HT20_Left Cheek_Ch149_w MSR_Ant 1_w_o_Holstery

DUT: 120703C13

Communication System: WLAN_5G; Frequency: 5745 MHz; Duty Cycle: 1:1

Medium: H5G_0814 Medium parameters used: $f = 5745$ MHz; $\sigma = 5.352$ mho/m; $\epsilon_r = 35.824$; $\rho = 1000$ kg/m³

Ambient Temperature : 21.7 °C ; Liquid Temperature : 20.2 °C

DASY5 Configuration:

- Probe: EX3DV4 - SN3590; ConvF(4.79, 4.79, 4.79); Calibrated: 2012/02/23;
- Sensor-Surface: 2mm (Mechanical Surface Detection)
- Electronics: DAE3 Sn579; Calibrated: 2012/04/27
- Phantom: SAM with CRP v5.0 Front; Type: QD000P40CD; Serial: TP:1653
- Measurement SW: DASY52, Version 52.8 (1); SEMCAD X Version 14.6.5 (6469)

Ch149/Area Scan (161x181x1): Measurement grid: dx=10mm, dy=10mm

Maximum value of SAR (interpolated) = 0.310 mW/g

Ch149/Zoom Scan (7x7x9)/Cube 0: Measurement grid: dx=4mm, dy=4mm, dz=2.5mm

Reference Value = 0 V/m; Power Drift = 0.06 dB

Peak SAR (extrapolated) = 0.266 mW/g

SAR(1 g) = 0.037 mW/g; SAR(10 g) = 0.00471 mW/g

Maximum value of SAR (measured) = 0.186 mW/g



P64 802.11n_HT20_Left Tilted_Ch149_w MSR_Ant 1_w_o_Holstery

DUT: 120703C13

Communication System: WLAN_5G; Frequency: 5745 MHz; Duty Cycle: 1:1

Medium: H5G_0814 Medium parameters used: $f = 5745$ MHz; $\sigma = 5.352$ mho/m; $\epsilon_r = 35.824$; $\rho = 1000$ kg/m³

Ambient Temperature : 21.7 °C ; Liquid Temperature : 20.2 °C

DASY5 Configuration:

- Probe: EX3DV4 - SN3590; ConvF(4.79, 4.79, 4.79); Calibrated: 2012/02/23;
- Sensor-Surface: 2mm (Mechanical Surface Detection)
- Electronics: DAE3 Sn579; Calibrated: 2012/04/27
- Phantom: SAM with CRP v5.0 Front; Type: QD000P40CD; Serial: TP:1653
- Measurement SW: DASY52, Version 52.8 (1); SEMCAD X Version 14.6.5 (6469)

Ch149/Area Scan (161x181x1): Measurement grid: dx=10mm, dy=10mm

Maximum value of SAR (interpolated) = 0.165 mW/g

Ch149/Zoom Scan (7x7x9)/Cube 0: Measurement grid: dx=4mm, dy=4mm, dz=2.5mm

Reference Value = 0 V/m; Power Drift = 0.08 dB

Peak SAR (extrapolated) = 0.129 mW/g

SAR(1 g) = 0.00314 mW/g; SAR(10 g) = 0.000449 mW/g

Maximum value of SAR (measured) = 0.0645 mW/g

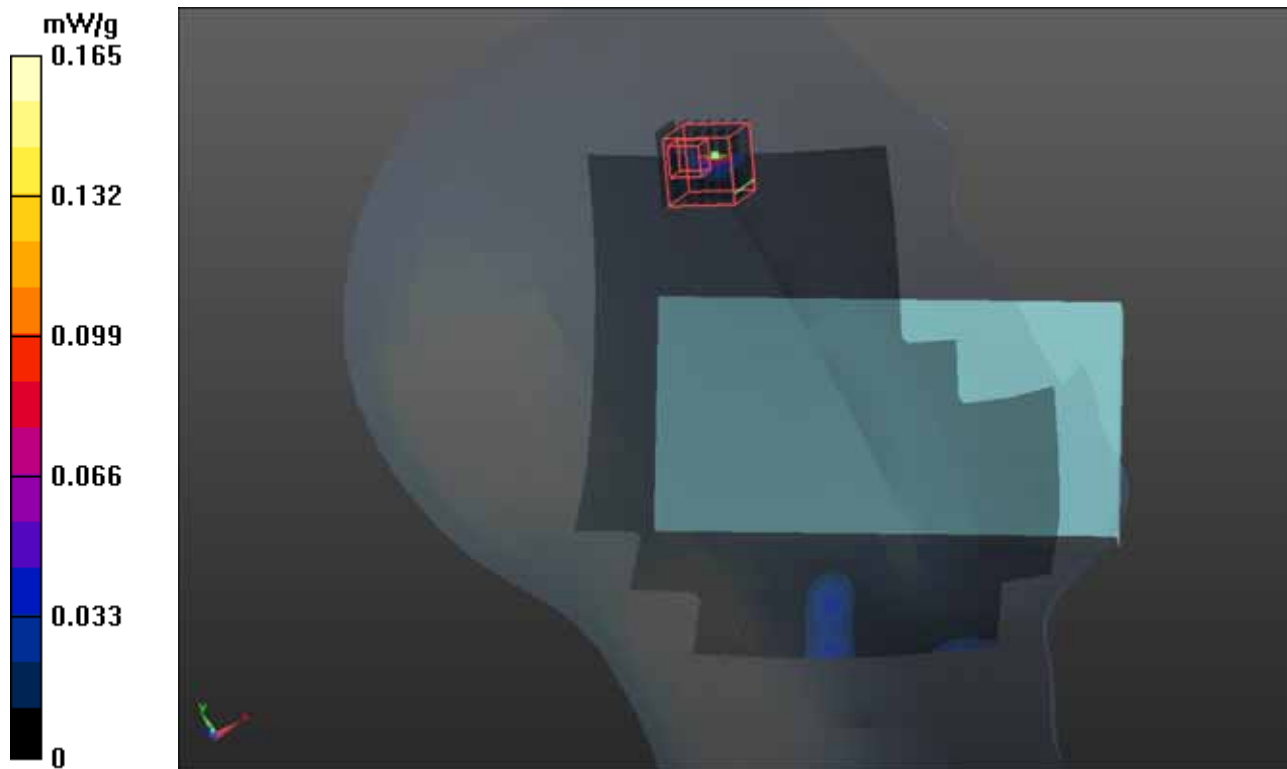

P67 802.11b_Front Face_1.5cm_Ch01_w_o MSR_ANT 0_w_o Holster

DUT: 120703C13

Communication System: 802.11b; Frequency: 2412 MHz; Duty Cycle: 1:1

Medium: B2450_0815 Medium parameters used: $f = 2412$ MHz; $\sigma = 1.95$ mho/m; $\epsilon_r = 52.9$; $\rho = 1000$ kg/m³

Ambient Temperature : 21.6 °C ; Liquid Temperature : 20.5 °C

DASY4 Configuration:

- Probe: EX3DV4 - SN3650; ConvF(6.89, 6.89, 6.89); Calibrated: 2011/10/26
- Sensor-Surface: 2mm (Mechanical Surface Detection)
- Electronics: DAE4 Sn1277; Calibrated: 2012/07/19
- Phantom: SAM Phantom_Front; Type: SAM V4.0; Serial: TP 1654
- Measurement SW: DASY4, V4.7 Build 80; Postprocessing SW: SEMCAD, V1.8 Build 186

Ch01/Area Scan (61x101x1): Measurement grid: dx=20mm, dy=20mm

Maximum value of SAR (interpolated) = 0.068 mW/g

Ch01/Zoom Scan (5x5x7)/Cube 0: Measurement grid: dx=8mm, dy=8mm, dz=5mm

Reference Value = 1.70 V/m; Power Drift = -0.15 dB

Peak SAR (extrapolated) = 0.066 W/kg

SAR(1 g) = 0.037 mW/g; SAR(10 g) = 0.018 mW/g

Maximum value of SAR (measured) = 0.053 mW/g

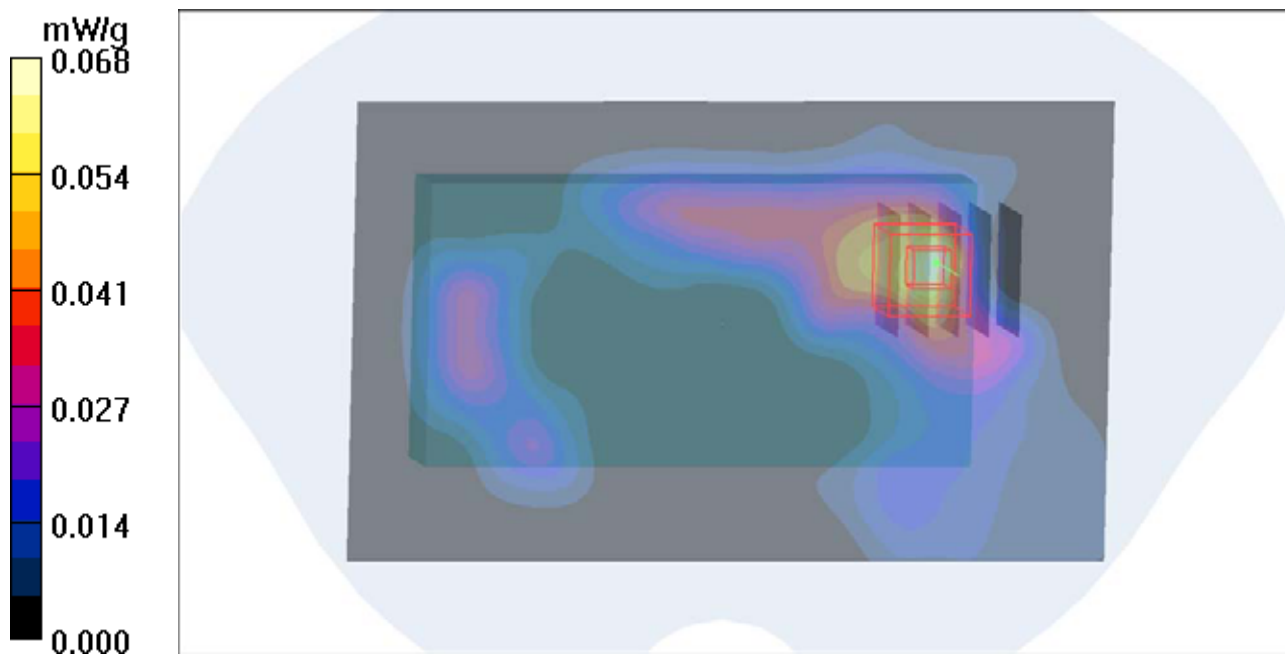

P68 802.11b_Front Face_1.5cm_Ch01_w MSR_ANT 0_w_o Holster

DUT: 120703C13

Communication System: 802.11b; Frequency: 2412 MHz; Duty Cycle: 1:1

Medium: B2450_0815 Medium parameters used: $f = 2412$ MHz; $\sigma = 1.95$ mho/m; $\epsilon_r = 52.9$; $\rho = 1000$ kg/m³

Ambient Temperature : 21.6 °C; Liquid Temperature : 20.5 °C

DASY4 Configuration:

- Probe: EX3DV4 - SN3650; ConvF(6.89, 6.89, 6.89); Calibrated: 2011/10/26
- Sensor-Surface: 2mm (Mechanical Surface Detection)
- Electronics: DAE4 Sn1277; Calibrated: 2012/07/19
- Phantom: SAM Phantom_Front; Type: SAM V4.0; Serial: TP 1654
- Measurement SW: DASY4, V4.7 Build 80; Postprocessing SW: SEMCAD, V1.8 Build 186

Ch01/Area Scan (61x101x1): Measurement grid: dx=20mm, dy=20mm

Maximum value of SAR (interpolated) = 0.020 mW/g

Ch01/Zoom Scan (5x5x7)/Cube 0: Measurement grid: dx=8mm, dy=8mm, dz=5mm

Reference Value = 0.852 V/m; Power Drift = -0.011 dB

Peak SAR (extrapolated) = 0.018 W/kg

SAR(1 g) = 0.00602 mW/g; SAR(10 g) = 0.0019 mW/g

Maximum value of SAR (measured) = 0.014 mW/g

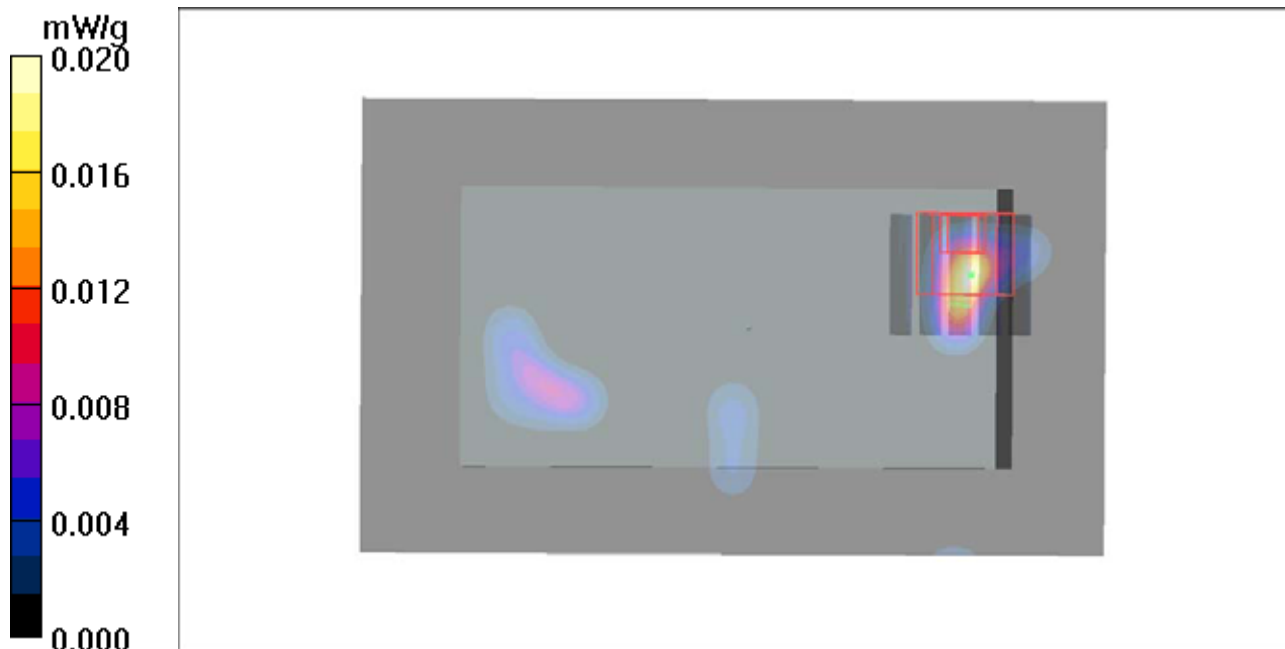

P69 802.11b_Rear Face_1.5cm_Ch01_w_o MSR_ANT 0_w_o Holster

DUT: 120703C13

Communication System: 802.11b; Frequency: 2412 MHz; Duty Cycle: 1:1

Medium: B2450_0815 Medium parameters used: $f = 2412$ MHz; $\sigma = 1.95$ mho/m; $\epsilon_r = 52.9$; $\rho = 1000$ kg/m³

Ambient Temperature : 21.6 °C ; Liquid Temperature : 20.5 °C

DASY4 Configuration:

- Probe: EX3DV4 - SN3650; ConvF(6.89, 6.89, 6.89); Calibrated: 2011/10/26
- Sensor-Surface: 2mm (Mechanical Surface Detection)
- Electronics: DAE4 Sn1277; Calibrated: 2012/07/19
- Phantom: SAM Phantom_Front; Type: SAM V4.0; Serial: TP 1654
- Measurement SW: DASY4, V4.7 Build 80; Postprocessing SW: SEMCAD, V1.8 Build 186

Ch01/Area Scan (61x101x1): Measurement grid: dx=20mm, dy=20mm

Maximum value of SAR (interpolated) = 0.222 mW/g

Ch01/Zoom Scan (5x5x7)/Cube 0: Measurement grid: dx=8mm, dy=8mm, dz=5mm

Reference Value = 6.83 V/m; Power Drift = -0.153 dB

Peak SAR (extrapolated) = 0.294 W/kg

SAR(1 g) = 0.161 mW/g; SAR(10 g) = 0.091 mW/g

Maximum value of SAR (measured) = 0.225 mW/g

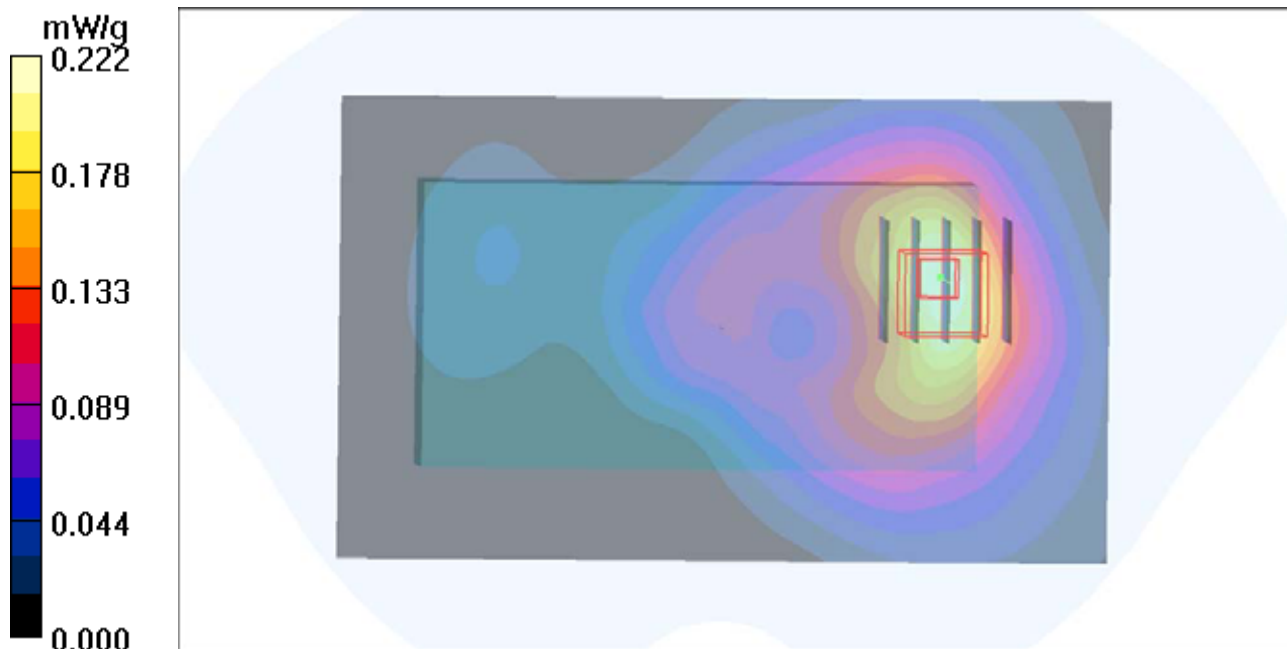

P135 802.11b_Front Face_1.5cm_Ch01_w_o MSR_ANT 1_w_o Holster

DUT: 120703C13

Communication System: 802.11b; Frequency: 2412 MHz; Duty Cycle: 1:1

Medium: B2450_0815 Medium parameters used: $f = 2412$ MHz; $\sigma = 1.95$ mho/m; $\epsilon_r = 52.9$; $\rho = 1000$ kg/m³

Ambient Temperature : 21.6 °C ; Liquid Temperature : 20.5 °C

DASY4 Configuration:

- Probe: EX3DV4 - SN3650; ConvF(6.89, 6.89, 6.89); Calibrated: 2011/10/26
- Sensor-Surface: 2mm (Mechanical Surface Detection)
- Electronics: DAE4 Sn1277; Calibrated: 2012/07/19
- Phantom: SAM Phantom_Front; Type: SAM V4.0; Serial: TP 1654
- Measurement SW: DASY4, V4.7 Build 80; Postprocessing SW: SEMCAD, V1.8 Build 186

Ch01/Area Scan (61x101x1): Measurement grid: dx=20mm, dy=20mm

Maximum value of SAR (interpolated) = 0.097 mW/g

Ch01/Zoom Scan (5x5x7)/Cube 0: Measurement grid: dx=8mm, dy=8mm, dz=5mm

Reference Value = 2.55 V/m; Power Drift = 0.064 dB

Peak SAR (extrapolated) = 0.044 W/kg

SAR(1 g) = 0.026 mW/g; SAR(10 g) = 0.013 mW/g

Maximum value of SAR (measured) = 0.035 mW/g

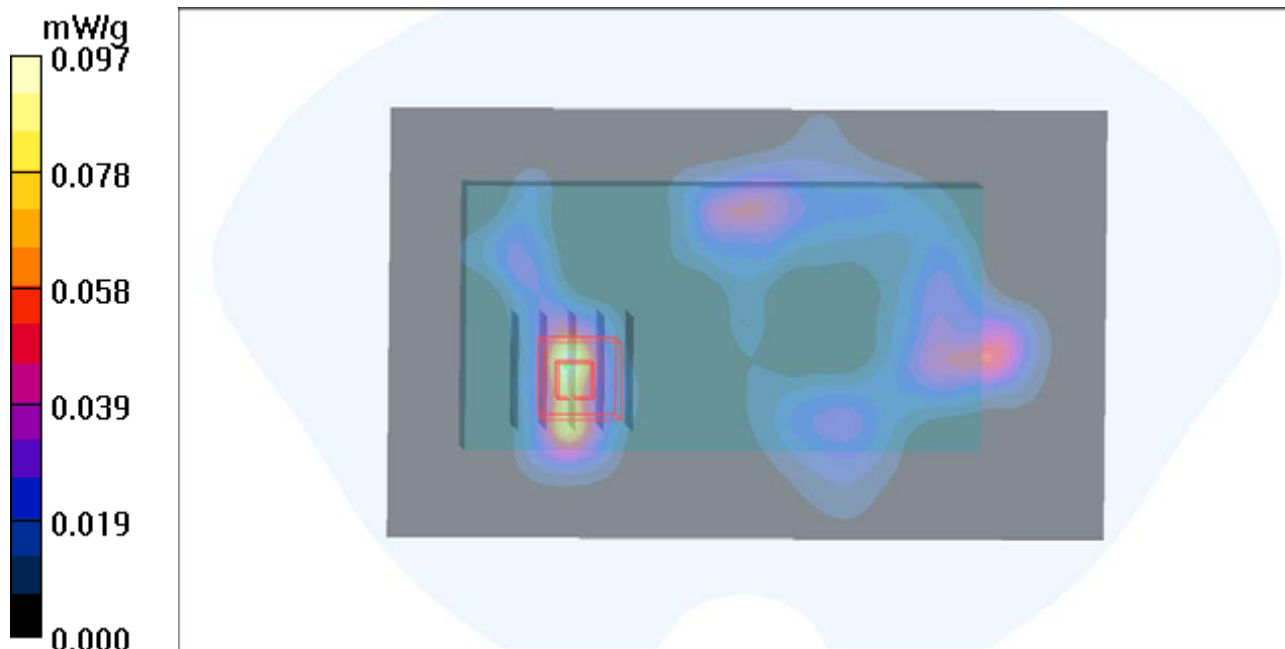

P136 802.11b_Front Face_1.5cm_Ch01_w MSR_ANT 1_w_o Holster

DUT: 120703C13

Communication System: 802.11b; Frequency: 2412 MHz; Duty Cycle: 1:1

Medium: B2450_0815 Medium parameters used: $f = 2412$ MHz; $\sigma = 1.95$ mho/m; $\epsilon_r = 52.9$; $\rho = 1000$ kg/m³

Ambient Temperature : 21.6 °C ; Liquid Temperature : 20.5 °C

DASY4 Configuration:

- Probe: EX3DV4 - SN3650; ConvF(6.89, 6.89, 6.89); Calibrated: 2011/10/26
- Sensor-Surface: 2mm (Mechanical Surface Detection)
- Electronics: DAE4 Sn1277; Calibrated: 2012/07/19
- Phantom: SAM Phantom_Front; Type: SAM V4.0; Serial: TP 1654
- Measurement SW: DASY4, V4.7 Build 80; Postprocessing SW: SEMCAD, V1.8 Build 186

Ch01/Area Scan (61x101x1): Measurement grid: dx=20mm, dy=20mm

Maximum value of SAR (interpolated) = 0.027 mW/g

Ch01/Zoom Scan (5x5x7)/Cube 0: Measurement grid: dx=8mm, dy=8mm, dz=5mm

Reference Value = 1.51 V/m; Power Drift = 0.155 dB

Peak SAR (extrapolated) = 0.049 W/kg

SAR(1 g) = 0.018 mW/g; SAR(10 g) = 0.00812 mW/g

Maximum value of SAR (measured) = 0.025 mW/g

Ch01/Zoom Scan (5x5x7)/Cube 1: Measurement grid: dx=8mm, dy=8mm, dz=5mm

Reference Value = 1.51 V/m; Power Drift = 0.155 dB

Peak SAR (extrapolated) = 0.025 W/kg

SAR(1 g) = 0.015 mW/g; SAR(10 g) = 0.00712 mW/g

Maximum value of SAR (measured) = 0.022 mW/g

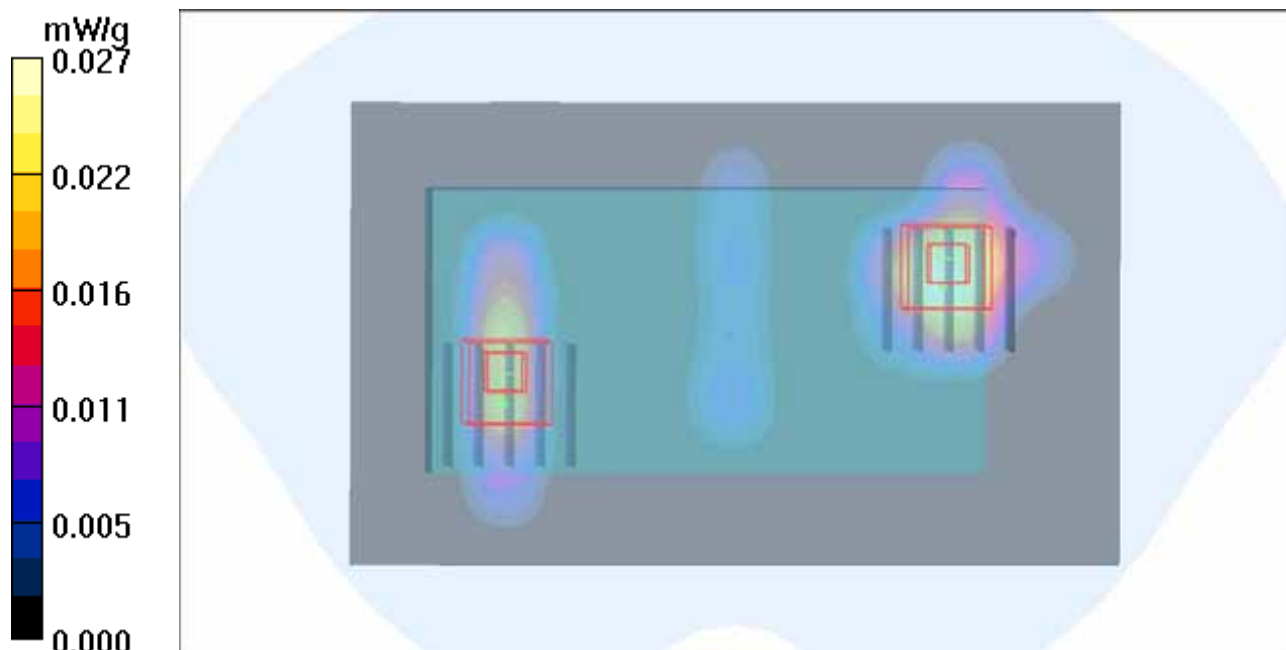

P134 802.11b_Rear Face_1.5cm_Ch01_w_o MSR_ANT 1_w_o Holster

DUT: 120703C13

Communication System: 802.11b; Frequency: 2412 MHz; Duty Cycle: 1:1

Medium: B2450_0815 Medium parameters used: $f = 2412$ MHz; $\sigma = 1.95$ mho/m; $\epsilon_r = 52.9$; $\rho = 1000$ kg/m³

Ambient Temperature : 21.6 °C ; Liquid Temperature : 20.5 °C

DASY4 Configuration:

- Probe: EX3DV4 - SN3650; ConvF(6.89, 6.89, 6.89); Calibrated: 2011/10/26
- Sensor-Surface: 2mm (Mechanical Surface Detection)
- Electronics: DAE4 Sn1277; Calibrated: 2012/07/19
- Phantom: SAM Phantom_Front; Type: SAM V4.0; Serial: TP 1654
- Measurement SW: DASY4, V4.7 Build 80; Postprocessing SW: SEMCAD, V1.8 Build 186

Ch01/Area Scan (61x101x1): Measurement grid: dx=20mm, dy=20mm

Maximum value of SAR (interpolated) = 0.248 mW/g

Ch01/Zoom Scan (5x5x7)/Cube 0: Measurement grid: dx=8mm, dy=8mm, dz=5mm

Reference Value = 9.78 V/m; Power Drift = 0.042 dB

Peak SAR (extrapolated) = 0.292 W/kg

SAR(1 g) = 0.160 mW/g; SAR(10 g) = 0.090 mW/g

Maximum value of SAR (measured) = 0.220 mW/g

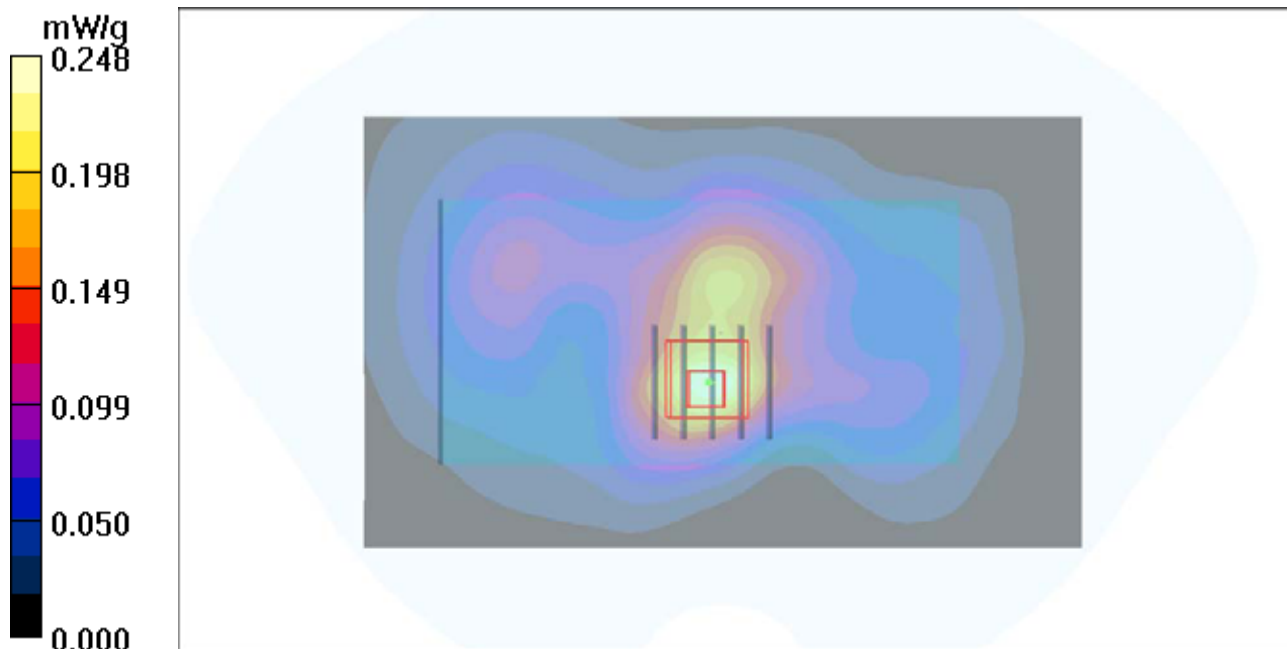

P77 802.11b_Front Face_0cm_Ch01_w_o MSR_ANT 0_w_o Earphone_w Holster

DUT: 120703C13

Communication System: 802.11b; Frequency: 2412 MHz; Duty Cycle: 1:1

Medium: B2450_0822 Medium parameters used: $f = 2412$ MHz; $\sigma = 1.917$ mho/m; $\epsilon_r = 51.835$; $\rho = 1000$ kg/m³

Ambient Temperature : 21.6 °C ; Liquid Temperature : 20.5 °C

DASY5 Configuration:

- Probe: EX3DV4 - SN3864; ConvF(7.49, 7.49, 7.49); Calibrated: 2012/07/19;
- Sensor-Surface: 2mm (Mechanical Surface Detection)
- Electronics: DAE4 Sn1277; Calibrated: 2012/07/19
- Phantom: SAM with CRP v5.0 Front; Type: QD000P40CD; Serial: TP:1653
- Measurement SW: DASY52, Version 52.8 (2); SEMCAD X Version 14.6.6 (6824)

Ch01/Area Scan (61x101x1): Measurement grid: dx=20mm, dy=20mm

Maximum value of SAR (interpolated) = 0.0464 W/kg

Ch01/Zoom Scan (5x5x7)/Cube 0: Measurement grid: dx=8mm, dy=8mm, dz=5mm

Reference Value = 0 V/m; Power Drift = 0.00 dB

Peak SAR (extrapolated) = 0.033 mW/g

SAR(1 g) = 0.019 mW/g; SAR(10 g) = 0.00813 mW/g

Maximum value of SAR (measured) = 0.0270 W/kg

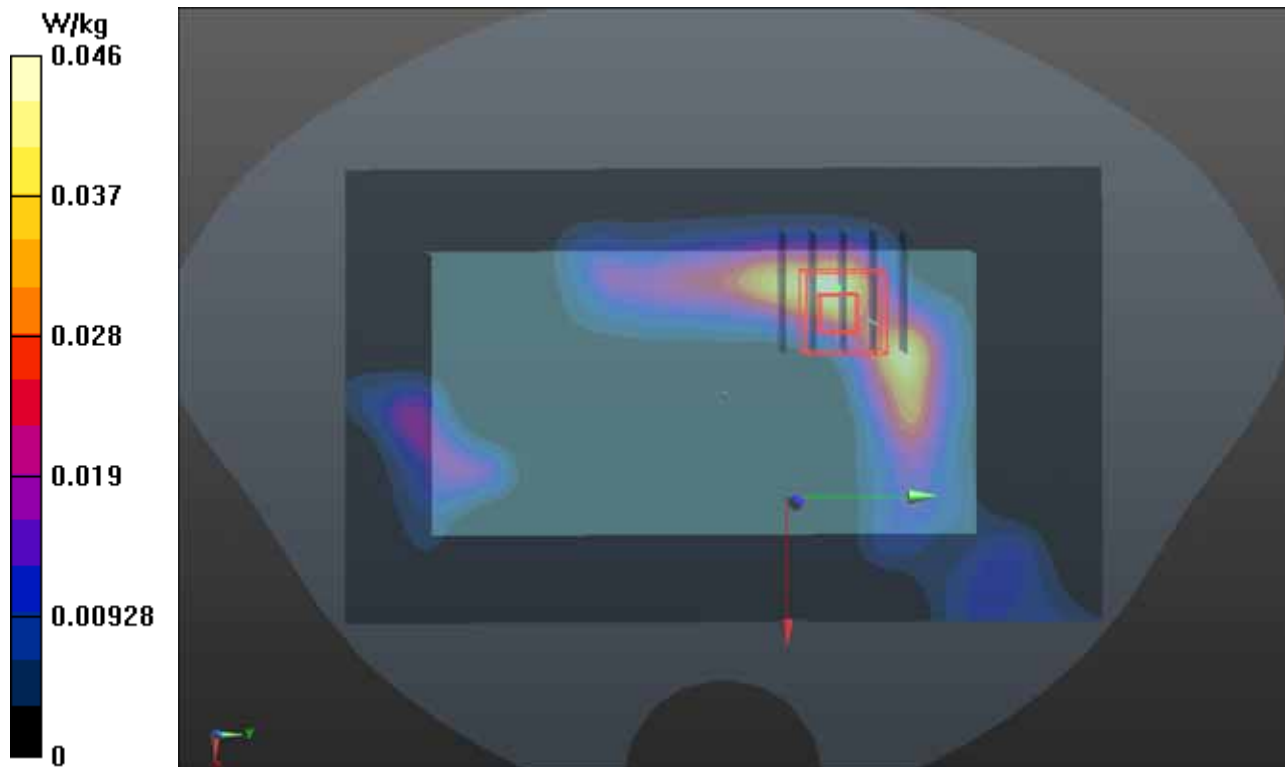

P78 802.11b_Rear Face_0cm_Ch01_w_o MSR_ANT 0_w_o Earphone_w Holster

DUT: 120703C13

Communication System: WLAN_2.4G; Frequency: 2412 MHz; Duty Cycle: 1:1

Medium: B2450_0822 Medium parameters used: $f = 2412$ MHz; $\sigma = 1.917$ mho/m; $\epsilon_r = 51.835$; $\rho = 1000$ kg/m³

Ambient Temperature : 21.6 °C ; Liquid Temperature : 20.5 °C

DASY5 Configuration:

- Probe: EX3DV4 - SN3864; ConvF(7.49, 7.49, 7.49); Calibrated: 2012/07/19;
- Sensor-Surface: 2mm (Mechanical Surface Detection)
- Electronics: DAE4 Sn1277; Calibrated: 2012/07/19
- Phantom: SAM with CRP v5.0 Front; Type: QD000P40CD; Serial: TP:1653
- Measurement SW: DASY52, Version 52.8 (2); SEMCAD X Version 14.6.6 (6824)

Ch01/Area Scan (61x101x1): Measurement grid: dx=20mm, dy=20mm

Maximum value of SAR (interpolated) = 0.387 W/kg

Ch01/Zoom Scan (5x5x7)/Cube 0: Measurement grid: dx=8mm, dy=8mm, dz=5mm

Reference Value = 9.099 V/m; Power Drift = -0.03 dB

Peak SAR (extrapolated) = 0.522 mW/g

SAR(1 g) = 0.280 mW/g; SAR(10 g) = 0.152 mW/g

Maximum value of SAR (measured) = 0.393 W/kg

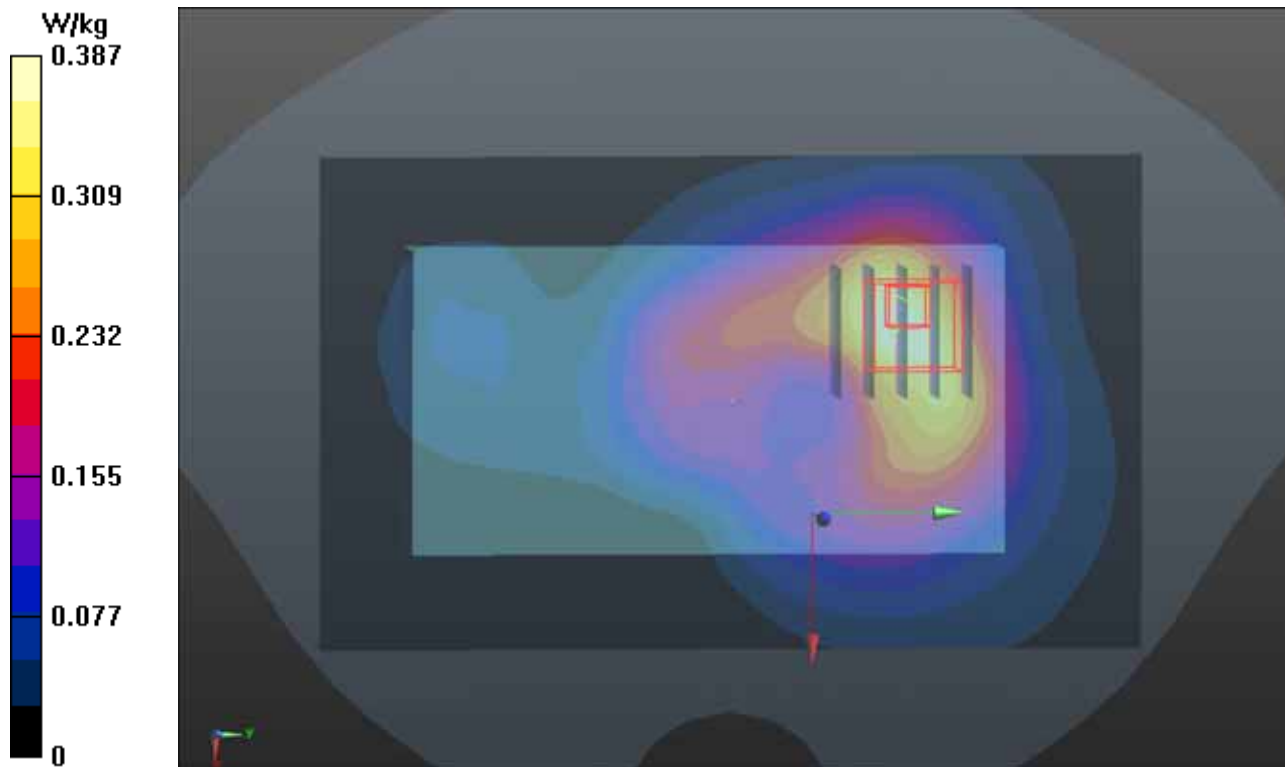

1g/10g Averaged SAR

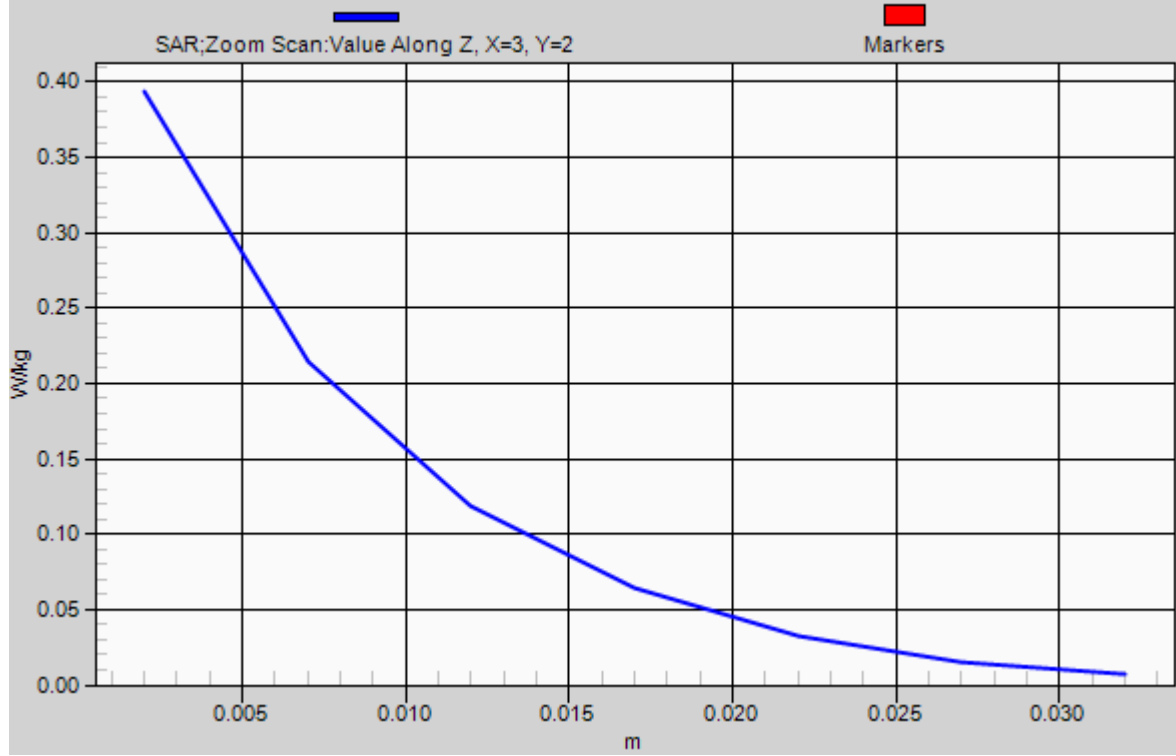

P81 802.11a_Front Face_1.5cm_Ch48_w_o MSR_ANT 0_w_o Holster

DUT: 120703C13

Communication System: 802.11a; Frequency: 5240 MHz; Duty Cycle: 1:1

Medium: B5G_0815 Medium parameters used: $f = 5240$ MHz; $\sigma = 5.36$ mho/m; $\epsilon_r = 49.1$; $\rho = 1000$ kg/m³

Ambient Temperature : 21.5 °C ; Liquid Temperature : 20.2 °C

DASY4 Configuration:

- Probe: EX3DV4 - SN3650; ConvF(4.28, 4.28, 4.28); Calibrated: 2011/10/26
- Sensor-Surface: 2mm (Mechanical Surface Detection)
- Electronics: DAE4 Sn1277; Calibrated: 2012/07/19
- Phantom: SAM Phantom_Left; Type: SAM V4.0; Serial: TP 1652
- Measurement SW: DASY4, V4.7 Build 80; Postprocessing SW: SEMCAD, V1.8 Build 186

Ch48/Area Scan (161x221x1): Measurement grid: dx=10mm, dy=10mm

Maximum value of SAR (interpolated) = 0.012 mW/g

Ch48/Zoom Scan (7x7x9)/Cube 0: Measurement grid: dx=4mm, dy=4mm, dz=2.5mm

Reference Value = 0.000 V/m; Power Drift = 0.025 dB

Peak SAR (extrapolated) = 0.042 W/kg

SAR(1 g) = 0.000195 mW/g; SAR(10 g) = 1.91e-005 mW/g

Maximum value of SAR (measured) = 0.042 mW/g

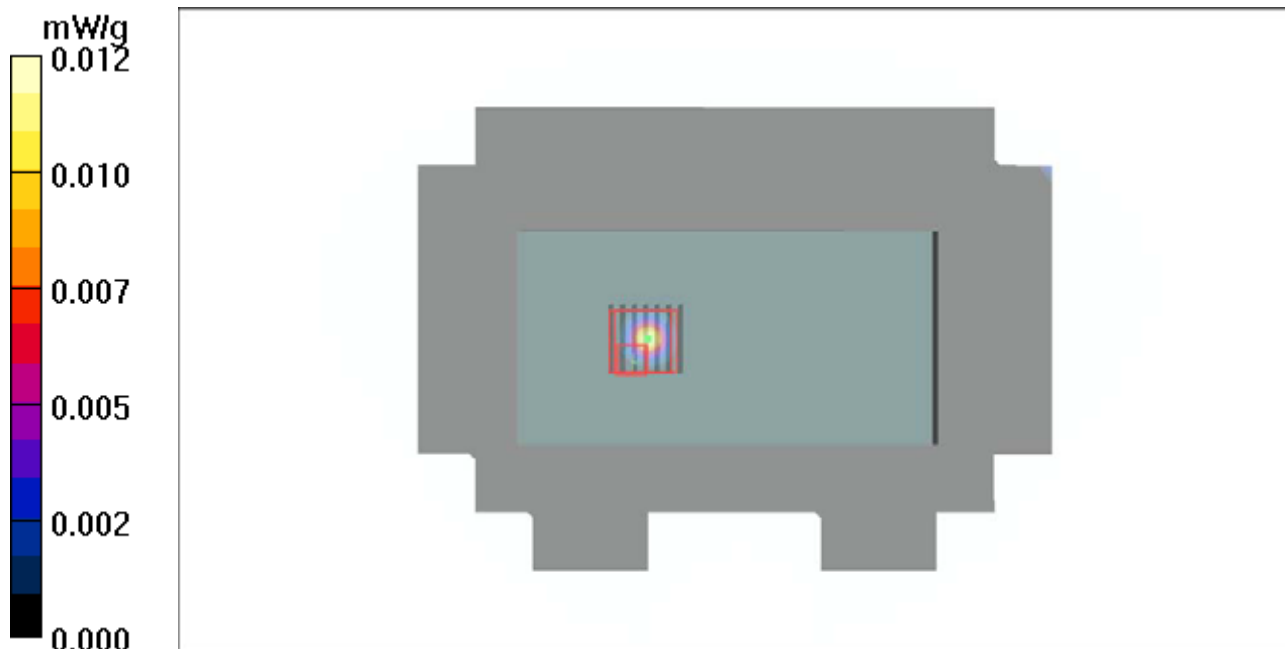

P83 802.11a_Rear Face_1.5cm_Ch48_w_o MSR_ANT 0_Earphone_w_o Holster

DUT: 120703C13

Communication System: WLAN 5G; Frequency: 5240 MHz; Duty Cycle: 1:1

Medium: B5G_0821 Medium parameters used: $f = 5240$ MHz; $\sigma = 5.302$ mho/m; $\epsilon_r = 51.038$; $\rho = 1000$ kg/m³

Ambient Temperature : 21.6 °C ; Liquid Temperature : 20.6 °C

DASY5 Configuration:

- Probe: EX3DV4 - SN3650; ConvF(4.28, 4.28, 4.28); Calibrated: 2011/10/26;
- Sensor-Surface: 2mm (Mechanical Surface Detection)
- Electronics: DAE4 Sn910; Calibrated: 2011/12/07
- Phantom: SAM Phantom_Front; Type: SAM V4.0; Serial: TP 1654
- Measurement SW: DASY52, Version 52.8 (2); SEMCAD X Version 14.6.6 (6824)

Ch48/Area Scan (161x221x1): Measurement grid: dx=10mm, dy=10mm

Maximum value of SAR (interpolated) = 0.311 W/kg

Ch48/Zoom Scan (7x7x9)/Cube 0: Measurement grid: dx=4mm, dy=4mm, dz=2.5mm

Reference Value = 3.210 V/m; Power Drift = 0.13 dB

Peak SAR (extrapolated) = 0.611 mW/g

SAR(1 g) = 0.178 mW/g; SAR(10 g) = 0.081 mW/g

Maximum value of SAR (measured) = 0.308 W/kg

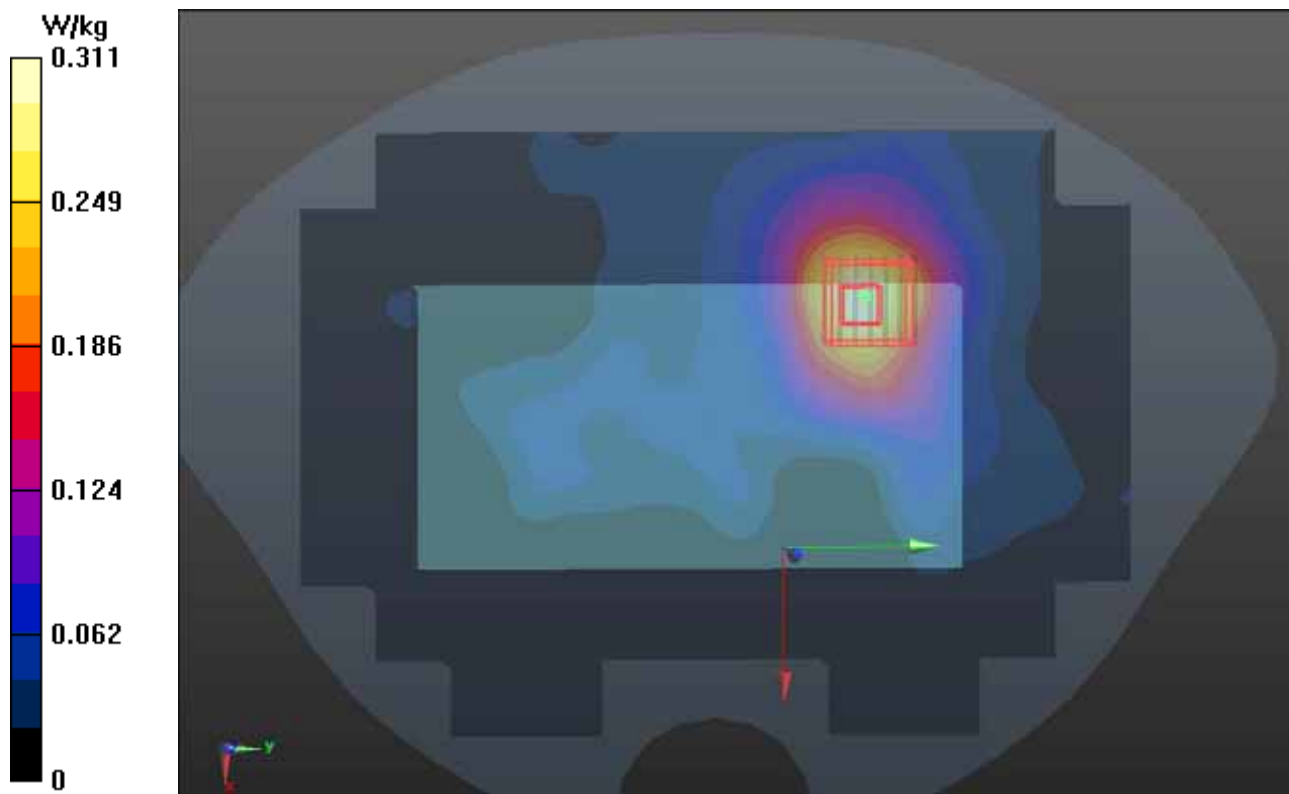

P85 802.11a_Front Face_1.5cm_Ch48_w_o MSR_ANT 1_Earphone_w_o Holster

DUT: 120703C13

Communication System: WLAN 5G; Frequency: 5240 MHz; Duty Cycle: 1:1

Medium: B5G_0821 Medium parameters used: $f = 5240$ MHz; $\sigma = 5.302$ mho/m; $\epsilon_r = 51.038$; $\rho = 1000$ kg/m³

Ambient Temperature : 21.6 °C ; Liquid Temperature : 20.6 °C

DASY5 Configuration:

- Probe: EX3DV4 - SN3650; ConvF(4.28, 4.28, 4.28); Calibrated: 2011/10/26;
- Sensor-Surface: 2mm (Mechanical Surface Detection)
- Electronics: DAE4 Sn910; Calibrated: 2011/12/07
- Phantom: SAM Phantom_Front; Type: SAM V4.0; Serial: TP 1654
- Measurement SW: DASY52, Version 52.8 (2); SEMCAD X Version 14.6.6 (6824)

Ch48/Area Scan (161x221x1): Measurement grid: dx=10mm, dy=10mm

Maximum value of SAR (interpolated) = 0.0568 W/kg

Ch48/Zoom Scan (7x7x9)/Cube 0: Measurement grid: dx=4mm, dy=4mm, dz=2.5mm

Reference Value = 1.304 V/m; Power Drift = 0.11 dB

Peak SAR (extrapolated) = 0.281 mW/g

SAR(1 g) = 0.00164 mW/g; SAR(10 g) = 0.000276 mW/g

Maximum value of SAR (measured) = 0.281 W/kg

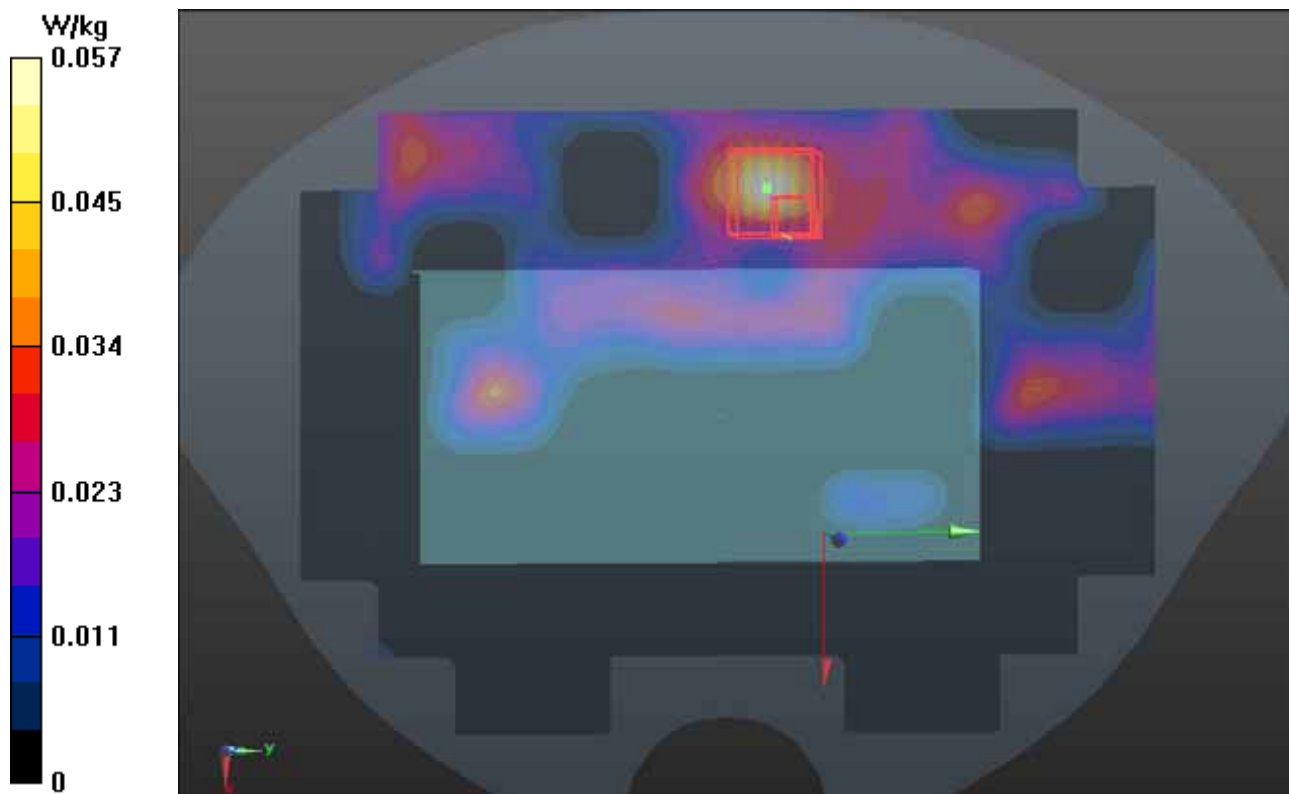

P86 802.11a_Front Face_1.5cm_Ch48_w MSR_ANT 1_Earphone_w_o Holster

DUT: 120703C13

Communication System: WLAN 5G; Frequency: 5240 MHz; Duty Cycle: 1:1

Medium: B5G_0821 Medium parameters used: $f = 5240$ MHz; $\sigma = 5.302$ mho/m; $\epsilon_r = 51.038$; $\rho = 1000$ kg/m³

Ambient Temperature : 21.6 °C ; Liquid Temperature : 20.6 °C

DASY5 Configuration:

- Probe: EX3DV4 - SN3650; ConvF(4.28, 4.28, 4.28); Calibrated: 2011/10/26;
- Sensor-Surface: 2mm (Mechanical Surface Detection)
- Electronics: DAE4 Sn910; Calibrated: 2011/12/07
- Phantom: SAM Phantom_Front; Type: SAM V4.0; Serial: TP 1654
- Measurement SW: DASY52, Version 52.8 (2); SEMCAD X Version 14.6.6 (6824)

Ch48/Area Scan (161x221x1): Measurement grid: dx=10mm, dy=10mm

Maximum value of SAR (interpolated) = 0.0415 W/kg

Ch48/Zoom Scan (7x7x9)/Cube 1: Measurement grid: dx=4mm, dy=4mm, dz=2.5mm

Reference Value = 1.538 V/m; Power Drift = -0.15 dB

Peak SAR (extrapolated) = 0.161 mW/g

SAR(1 g) = 0.019 mW/g; SAR(10 g) = 0.012 mW/g

Maximum value of SAR (measured) = 0.128 W/kg

Ch48/Zoom Scan (7x7x9)/Cube 0: Measurement grid: dx=4mm, dy=4mm, dz=2.5mm

Reference Value = 1.538 V/m; Power Drift = -0.15 dB

Peak SAR (extrapolated) = 0.091 mW/g

SAR(1 g) = 0.016 mW/g; SAR(10 g) = 0.012 mW/g

Maximum value of SAR (measured) = 0.0811 W/kg

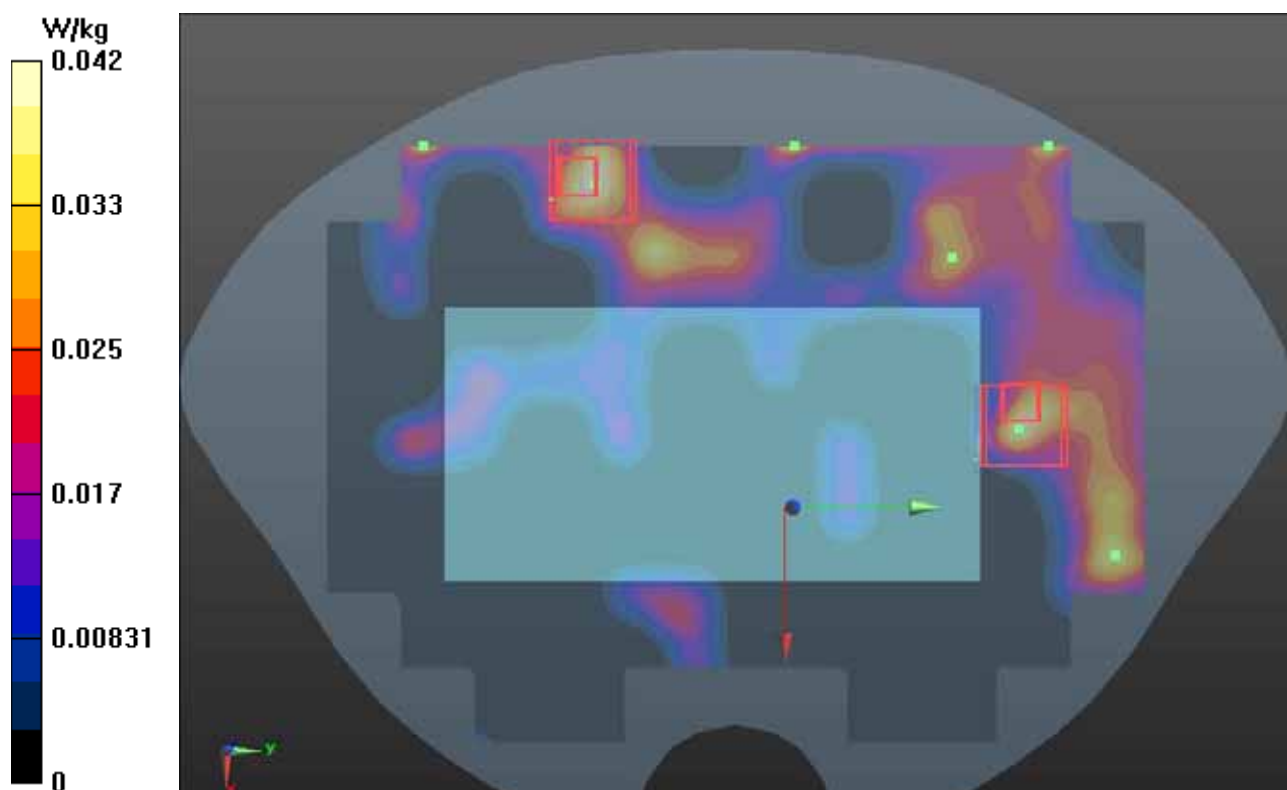

P87 802.11a_Rear Face_1.5cm_Ch48_w MSR_ANT 1_Earphone_w_o Holster

DUT: 120703C13

Communication System: WLAN 5G; Frequency: 5240 MHz; Duty Cycle: 1:1

Medium: B5G_0823 Medium parameters used: $f = 5240$ MHz; $\sigma = 5.346$ mho/m; $\epsilon_r = 49.138$; $\rho = 1000$ kg/m³

Ambient Temperature : 21.7 °C ; Liquid Temperature : 20.6 °C

DASY5 Configuration:

- Probe: EX3DV4 - SN3590; ConvF(4.89, 4.89, 4.89); Calibrated: 2012/02/23;
- Sensor-Surface: 2mm (Mechanical Surface Detection)
- Electronics: DAE3 Sn579; Calibrated: 2012/04/27
- Phantom: SAM with CRP v5.0 Front; Type: QD000P40CD; Serial: TP:1653
- Measurement SW: DASY52, Version 52.8 (2); SEMCAD X Version 14.6.6 (6824)

Ch48/Area Scan (161x221x1): Measurement grid: dx=10mm, dy=10mm

Maximum value of SAR (interpolated) = 0.455 W/kg

Ch48/Zoom Scan (7x7x9)/Cube 0: Measurement grid: dx=4mm, dy=4mm, dz=2.5mm

Reference Value = 4.684 V/m; Power Drift = 0.15 dB

Peak SAR (extrapolated) = 0.590 mW/g

SAR(1 g) = 0.185 mW/g; SAR(10 g) = 0.069 mW/g

Maximum value of SAR (measured) = 0.341 W/kg

Ch48/Zoom Scan (7x7x9)/Cube 1: Measurement grid: dx=4mm, dy=4mm, dz=2.5mm

Reference Value = 4.684 V/m; Power Drift = 0.15 dB

Peak SAR (extrapolated) = 0.435 mW/g

SAR(1 g) = 0.138 mW/g; SAR(10 g) = 0.056 mW/g

Maximum value of SAR (measured) = 0.254 W/kg

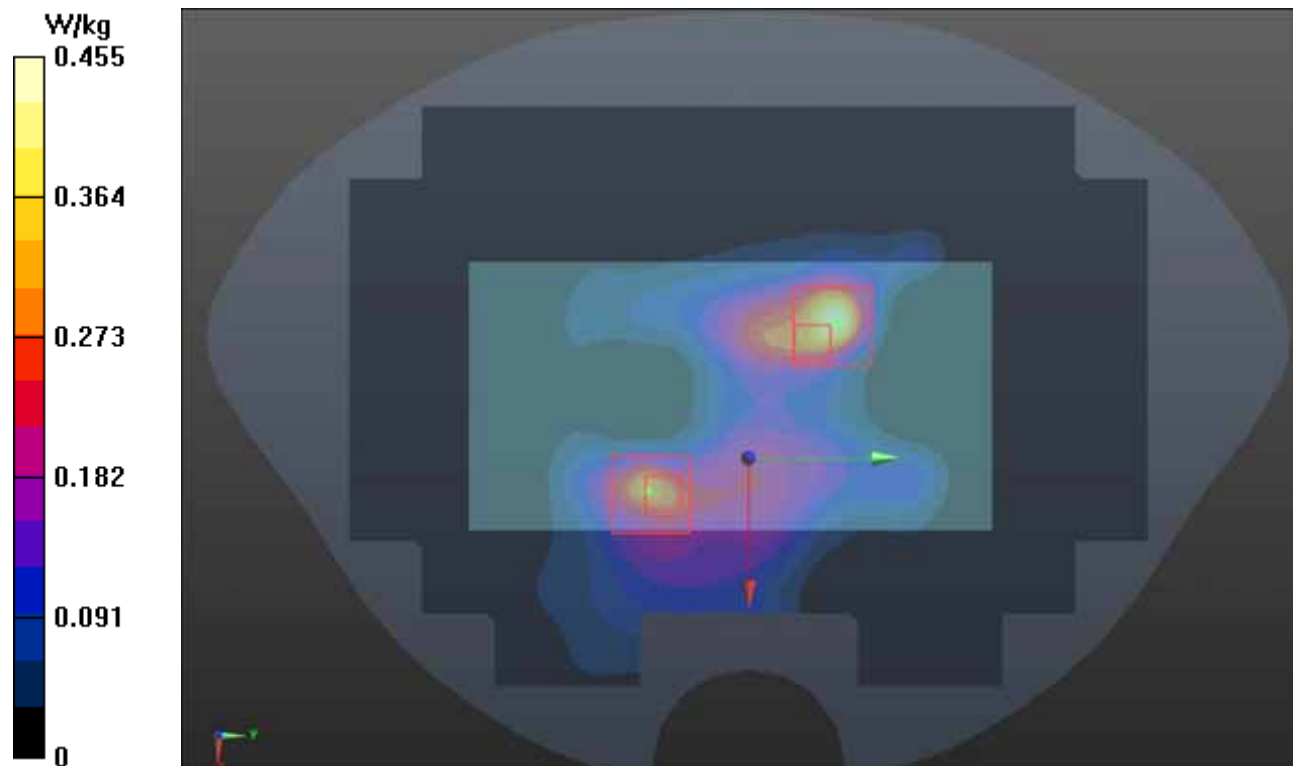

P89 802.11a_Front Face_0cm_Ch48_w MSR_ANT 1_w_o Earphone_w Holster

DUT: 120703C13

Communication System: WLAN 5G; Frequency: 5240 MHz; Duty Cycle: 1:1

Medium: B5G_0823 Medium parameters used: $f = 5240$ MHz; $\sigma = 5.346$ mho/m; $\epsilon_r = 49.138$; $\rho = 1000$ kg/m³

Ambient Temperature : 21.7 °C ; Liquid Temperature : 20.6 °C

DASY5 Configuration:

- Probe: EX3DV4 - SN3590; ConvF(4.89, 4.89, 4.89); Calibrated: 2012/02/23;
- Sensor-Surface: 2mm (Mechanical Surface Detection)
- Electronics: DAE3 Sn579; Calibrated: 2012/04/27
- Phantom: SAM with CRP v5.0 Front; Type: QD000P40CD; Serial: TP:1653
- Measurement SW: DASY52, Version 52.8 (2); SEMCAD X Version 14.6.6 (6824)

Ch48/Area Scan (161x221x1): Measurement grid: dx=10mm, dy=10mm

Maximum value of SAR (interpolated) = 0.0193 W/kg

Ch48/Zoom Scan (7x7x9)/Cube 0: Measurement grid: dx=4mm, dy=4mm, dz=2.5mm

Reference Value = 0 V/m; Power Drift = 0.00 dB

Peak SAR (extrapolated) = 0.252 mW/g

SAR(1 g) = 0.012 mW/g; SAR(10 g) = 0.0044 mW/g

Maximum value of SAR (measured) = 0.153 W/kg

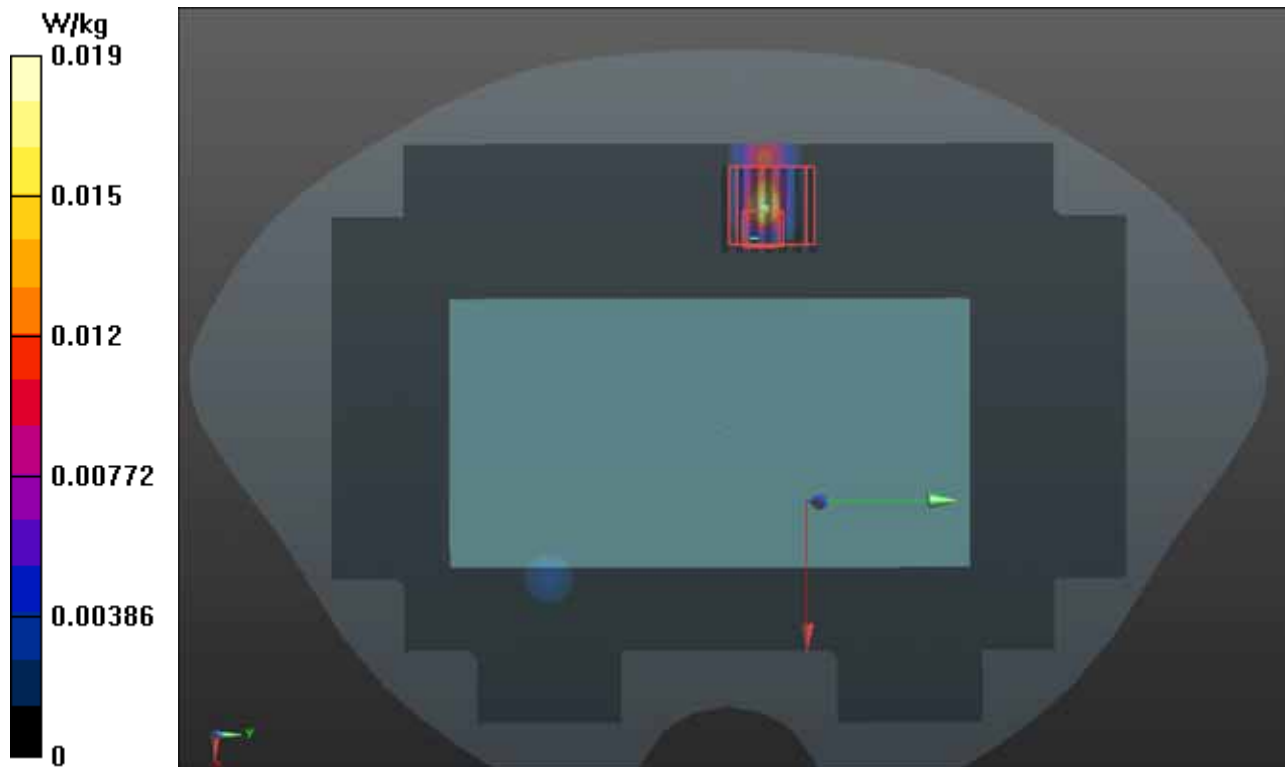

P90 802.11a_Rear Face_0cm_Ch48_w MSR_ANT 1_w_o Earphone_w Holster

DUT: 120703C13

Communication System: WLAN 5G; Frequency: 5240 MHz; Duty Cycle: 1:1

Medium: B5G_0823 Medium parameters used: $f = 5240$ MHz; $\sigma = 5.346$ mho/m; $\epsilon_r = 49.138$; $\rho = 1000$ kg/m³

Ambient Temperature : 21.7 °C ; Liquid Temperature : 20.6 °C

DASY5 Configuration:

- Probe: EX3DV4 - SN3590; ConvF(4.89, 4.89, 4.89); Calibrated: 2012/02/23;
- Sensor-Surface: 2mm (Mechanical Surface Detection)
- Electronics: DAE3 Sn579; Calibrated: 2012/04/27
- Phantom: SAM with CRP v5.0 Front; Type: QD000P40CD; Serial: TP:1653
- Measurement SW: DASY52, Version 52.8 (2); SEMCAD X Version 14.6.6 (6824)

Ch48/Area Scan (161x221x1): Measurement grid: dx=10mm, dy=10mm

Maximum value of SAR (interpolated) = 0.462 W/kg

Ch48/Zoom Scan (7x7x9)/Cube 1: Measurement grid: dx=4mm, dy=4mm, dz=2.5mm

Reference Value = 3.930 V/m; Power Drift = 0.12 dB

Peak SAR (extrapolated) = 0.850 mW/g

SAR(1 g) = 0.267 mW/g; SAR(10 g) = 0.099 mW/g

Maximum value of SAR (measured) = 0.489 W/kg

Ch48/Zoom Scan (7x7x9)/Cube 0: Measurement grid: dx=4mm, dy=4mm, dz=2.5mm

Reference Value = 3.930 V/m; Power Drift = 0.12 dB

Peak SAR (extrapolated) = 0.760 mW/g

SAR(1 g) = 0.213 mW/g; SAR(10 g) = 0.082 mW/g

Maximum value of SAR (measured) = 0.395 W/kg

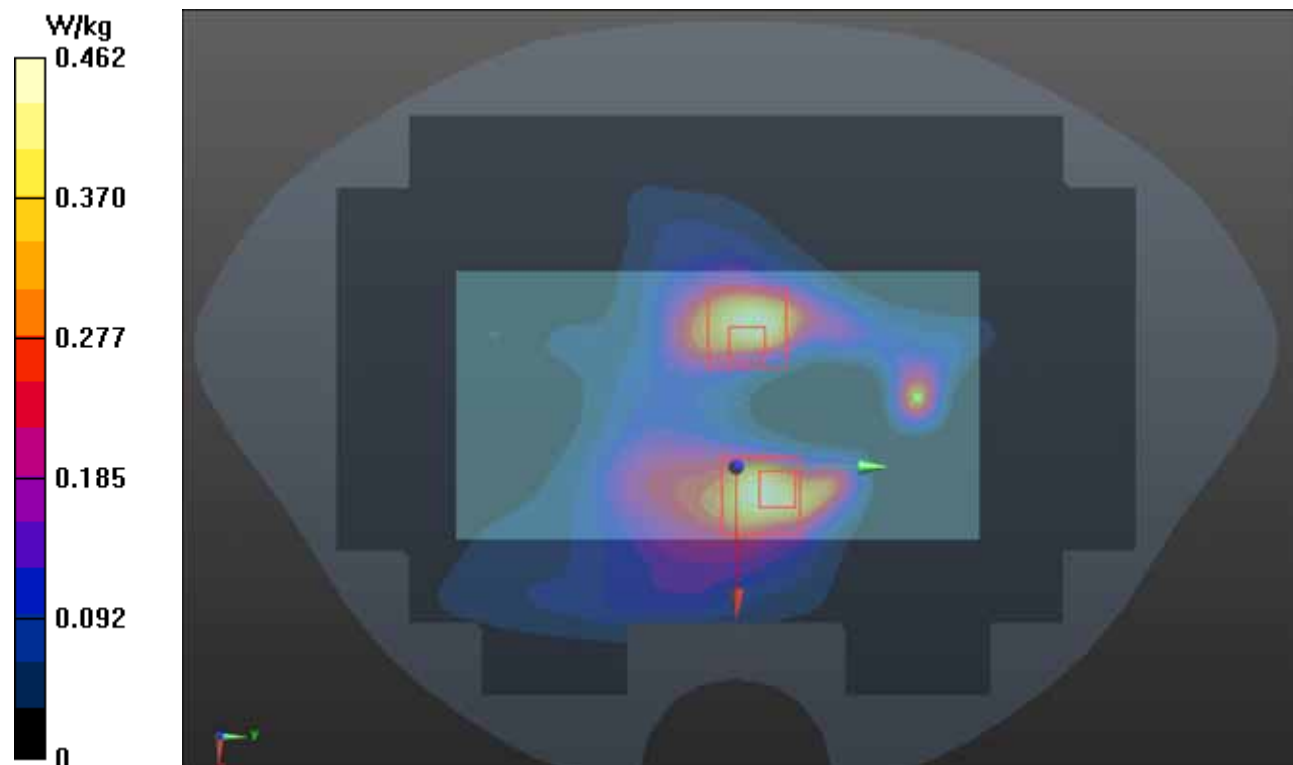

1g/10g Averaged SAR

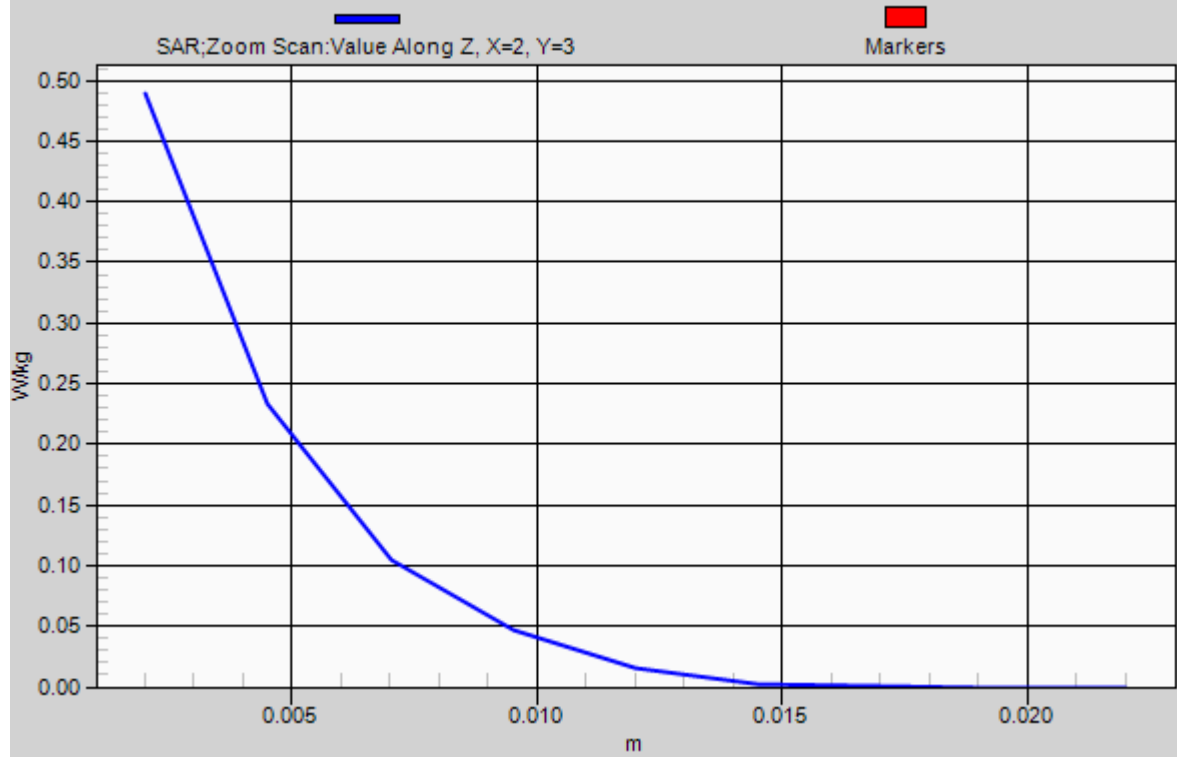

P92 802.11a_Front Face_1.5cm_Ch64_w_o MSR_ANT 0_Earphone_w_o Holster

DUT: 120703C13

Communication System: WLAN_5G; Frequency: 5320 MHz; Duty Cycle: 1:1

Medium: B5G_0823 Medium parameters used: $f = 5320$ MHz; $\sigma = 5.428$ mho/m; $\epsilon_r = 48.934$; $\rho = 1000$ kg/m³

Ambient Temperature : 21.7 °C ; Liquid Temperature : 20.6 °C

DASY5 Configuration:

- Probe: EX3DV4 - SN3590; ConvF(4.81, 4.81, 4.81); Calibrated: 2012/02/23;
- Sensor-Surface: 2mm (Mechanical Surface Detection)
- Electronics: DAE3 Sn579; Calibrated: 2012/04/27
- Phantom: SAM with CRP v5.0 Front; Type: QD000P40CD; Serial: TP:1653
- Measurement SW: DASY52, Version 52.8 (2); SEMCAD X Version 14.6.6 (6824)

Ch64/Area Scan (161x221x1): Measurement grid: dx=10mm, dy=10mm

Maximum value of SAR (interpolated) = 0.131 W/kg

Ch64/Zoom Scan (7x7x9)/Cube 0: Measurement grid: dx=4mm, dy=4mm, dz=2.5mm

Reference Value = 0 V/m; Power Drift = 0.05 dB

Peak SAR (extrapolated) = 0.270 mW/g

SAR(1 g) = 0.026 mW/g; SAR(10 g) = 0.00599 mW/g

Maximum value of SAR (measured) = 0.227 W/kg

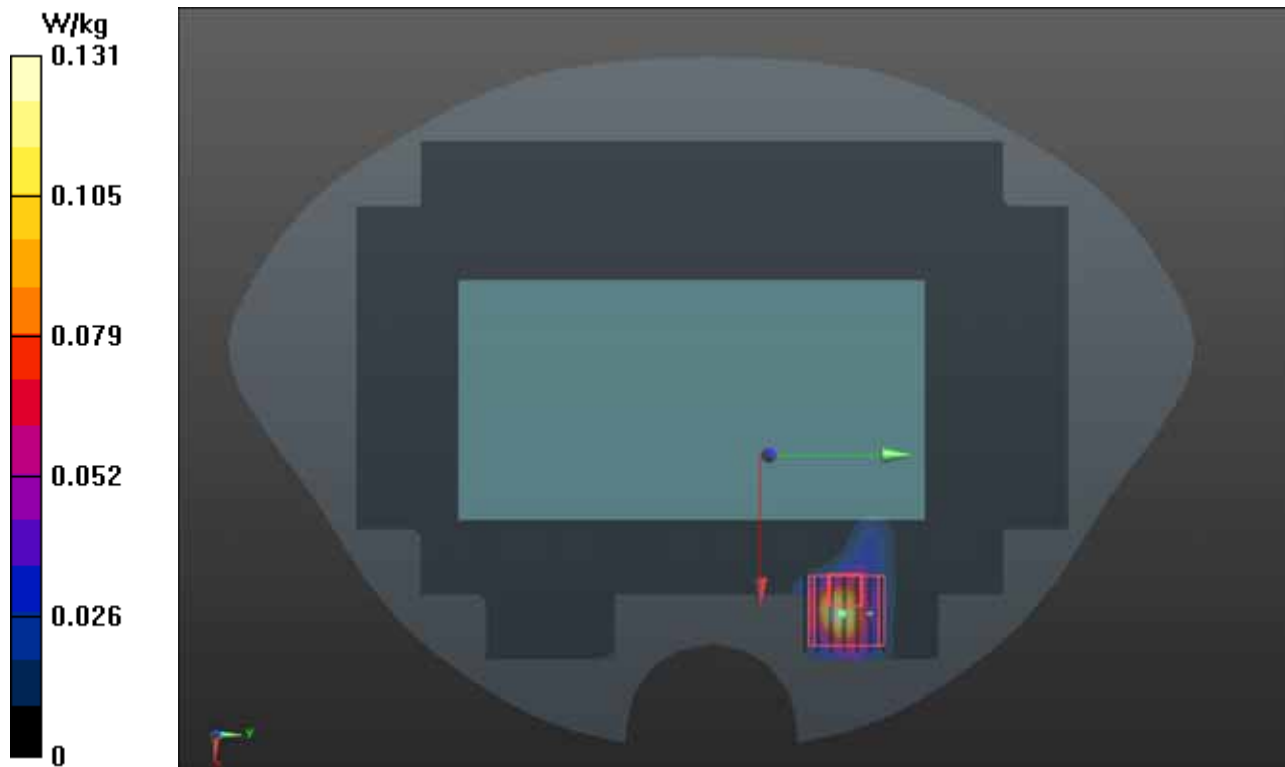

P93 802.11a_Front Face_1.5cm_Ch64_w_MSR_ANT 0_Earphone_w_o Holster

DUT: 120703C13

Communication System: WLAN_5G; Frequency: 5320 MHz; Duty Cycle: 1:1

Medium: B5G_0823 Medium parameters used: $f = 5320$ MHz; $\sigma = 5.428$ mho/m; $\epsilon_r = 48.934$; $\rho = 1000$ kg/m³

Ambient Temperature : 21.7 °C ; Liquid Temperature : 20.6 °C

DASY5 Configuration:

- Probe: EX3DV4 - SN3590; ConvF(4.81, 4.81, 4.81); Calibrated: 2012/02/23;
- Sensor-Surface: 2mm (Mechanical Surface Detection)
- Electronics: DAE3 Sn579; Calibrated: 2012/04/27
- Phantom: SAM with CRP v5.0 Front; Type: QD000P40CD; Serial: TP:1653
- Measurement SW: DASY52, Version 52.8 (2); SEMCAD X Version 14.6.6 (6824)

Ch64/Area Scan (161x221x1): Measurement grid: dx=10mm, dy=10mm

Maximum value of SAR (interpolated) = 0.0210 W/kg

Ch64/Zoom Scan (7x7x9)/Cube 0: Measurement grid: dx=4mm, dy=4mm, dz=2.5mm

Reference Value = 0 V/m; Power Drift = 0.01 dB

Peak SAR (extrapolated) = 0.087 mW/g

SAR(1 g) = 0.00539 mW/g; SAR(10 g) = 0.000594 mW/g

Maximum value of SAR (measured) = 0.0153 W/kg

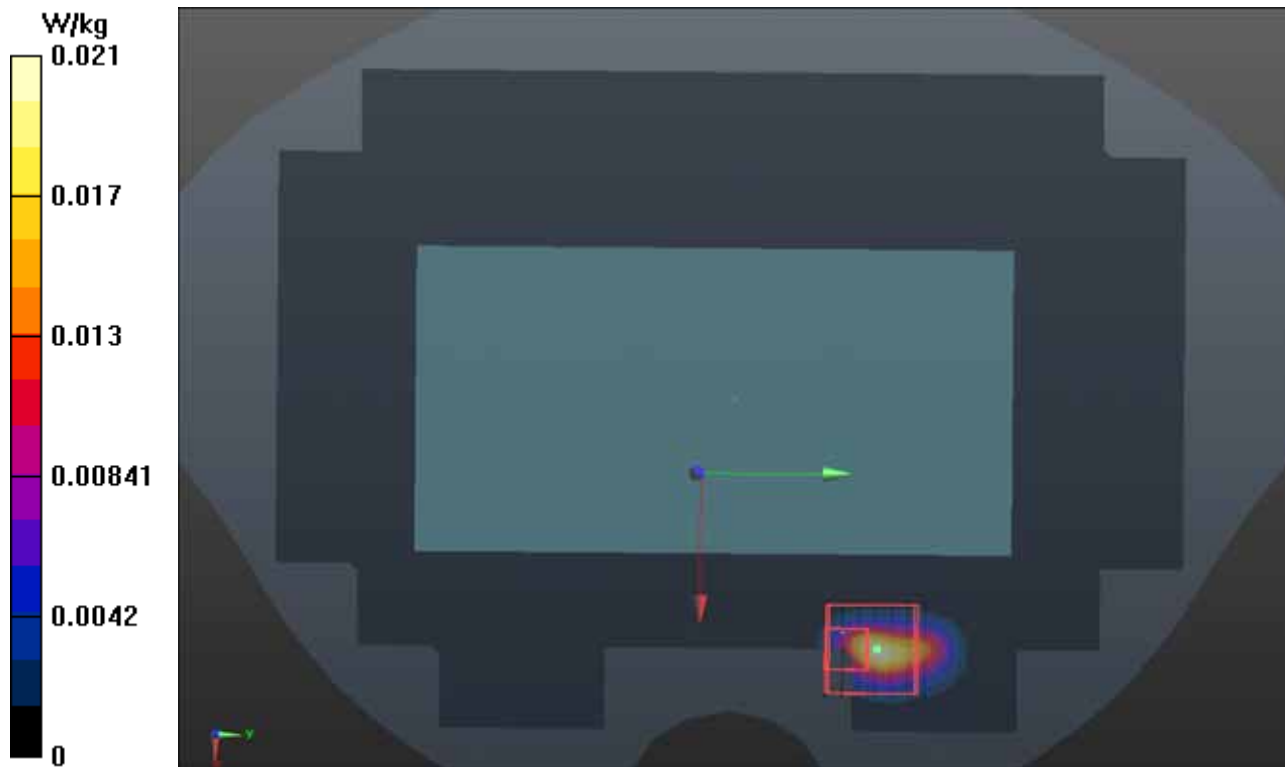

P94 802.11a_Front Face_1.5cm_Ch64_w_o MSR_ANT 0_Earphone_w_o Holster

DUT: 120703C13

Communication System: WLAN_5G; Frequency: 5320 MHz; Duty Cycle: 1:1

Medium: B5G_0823 Medium parameters used: $f = 5320$ MHz; $\sigma = 5.428$ mho/m; $\epsilon_r = 48.934$; $\rho = 1000$ kg/m³

Ambient Temperature : 21.7 °C ; Liquid Temperature : 20.6 °C

DASY5 Configuration:

- Probe: EX3DV4 - SN3590; ConvF(4.81, 4.81, 4.81); Calibrated: 2012/02/23;
- Sensor-Surface: 2mm (Mechanical Surface Detection)
- Electronics: DAE3 Sn579; Calibrated: 2012/04/27
- Phantom: SAM with CRP v5.0 Front; Type: QD000P40CD; Serial: TP:1653
- Measurement SW: DASY52, Version 52.8 (2); SEMCAD X Version 14.6.6 (6824)

Ch64/Area Scan (161x221x1): Measurement grid: dx=10mm, dy=10mm

Maximum value of SAR (interpolated) = 0.533 W/kg

Ch64/Zoom Scan (7x7x9)/Cube 0: Measurement grid: dx=4mm, dy=4mm, dz=2.5mm

Reference Value = 3.980 V/m; Power Drift = -0.16 dB

Peak SAR (extrapolated) = 1.723 mW/g

SAR(1 g) = 0.260 mW/g; SAR(10 g) = 0.085 mW/g

Maximum value of SAR (measured) = 0.667 W/kg

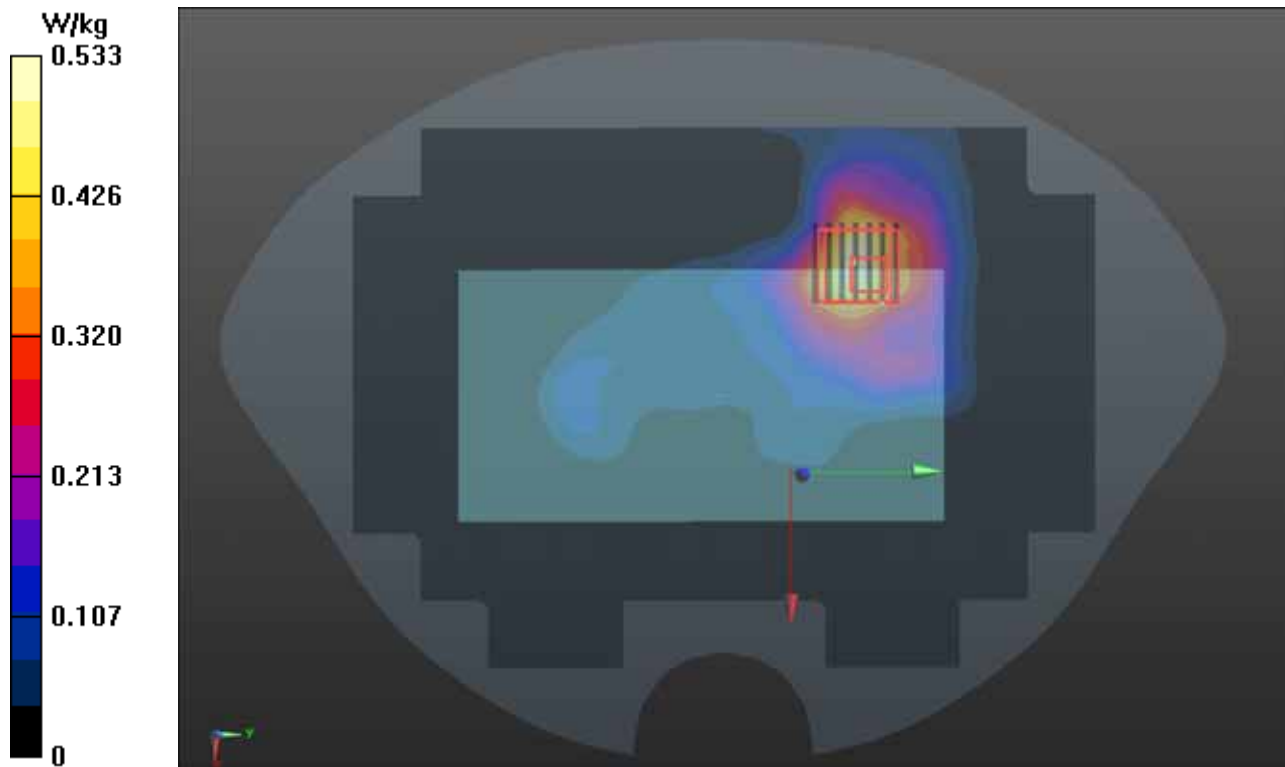

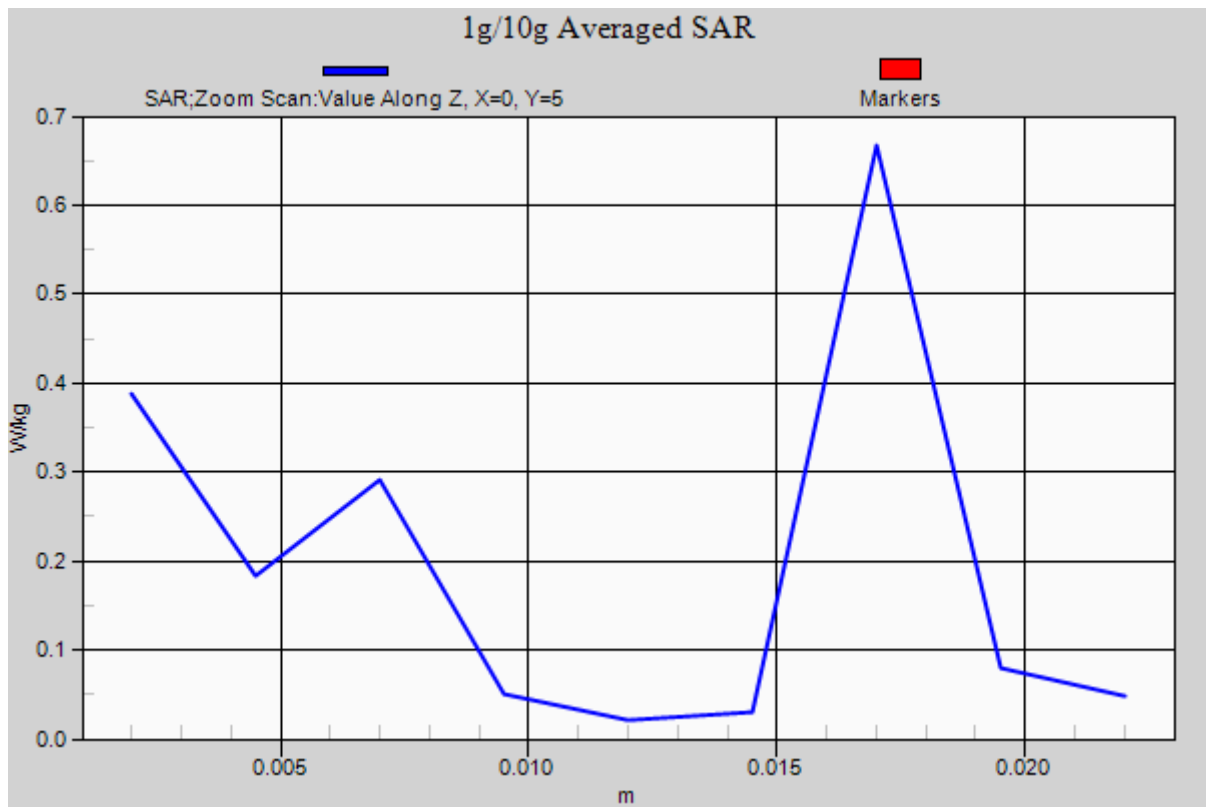

P96 802.11a_Front Face_1.5cm_Ch64_w_o MSR_ANT 1_Earphone_w_o Holster

DUT: 120703C13

Communication System: WLAN_5G; Frequency: 5320 MHz; Duty Cycle: 1:1

Medium: B5G_0823 Medium parameters used: $f = 5320$ MHz; $\sigma = 5.428$ mho/m; $\epsilon_r = 48.934$; $\rho = 1000$ kg/m³

Ambient Temperature : 21.7 °C ; Liquid Temperature : 20.6 °C

DASY5 Configuration:

- Probe: EX3DV4 - SN3590; ConvF(4.81, 4.81, 4.81); Calibrated: 2012/02/23;
- Sensor-Surface: 2mm (Mechanical Surface Detection)
- Electronics: DAE3 Sn579; Calibrated: 2012/04/27
- Phantom: SAM with CRP v5.0 Front; Type: QD000P40CD; Serial: TP:1653
- Measurement SW: DASY52, Version 52.8 (2); SEMCAD X Version 14.6.6 (6824)

Ch64/Area Scan (161x221x1): Measurement grid: dx=10mm, dy=10mm

Maximum value of SAR (interpolated) = 0.0736 W/kg

Ch64/Zoom Scan (7x7x9)/Cube 1: Measurement grid: dx=4mm, dy=4mm, dz=2.5mm

Reference Value = 0 V/m; Power Drift = 0.09 dB

Peak SAR (extrapolated) = 0.164 mW/g

SAR(1 g) = 0.017 mW/g; SAR(10 g) = 0.00643 mW/g

Maximum value of SAR (measured) = 0.0416 W/kg

Ch64/Zoom Scan (7x7x9)/Cube 0: Measurement grid: dx=4mm, dy=4mm, dz=2.5mm

Reference Value = 0 V/m; Power Drift = 0.09 dB

Peak SAR (extrapolated) = 0.102 mW/g

SAR(1 g) = 4.08e-007 mW/g; SAR(10 g) = n.a.

Maximum value of SAR (measured) = 0.102 W/kg

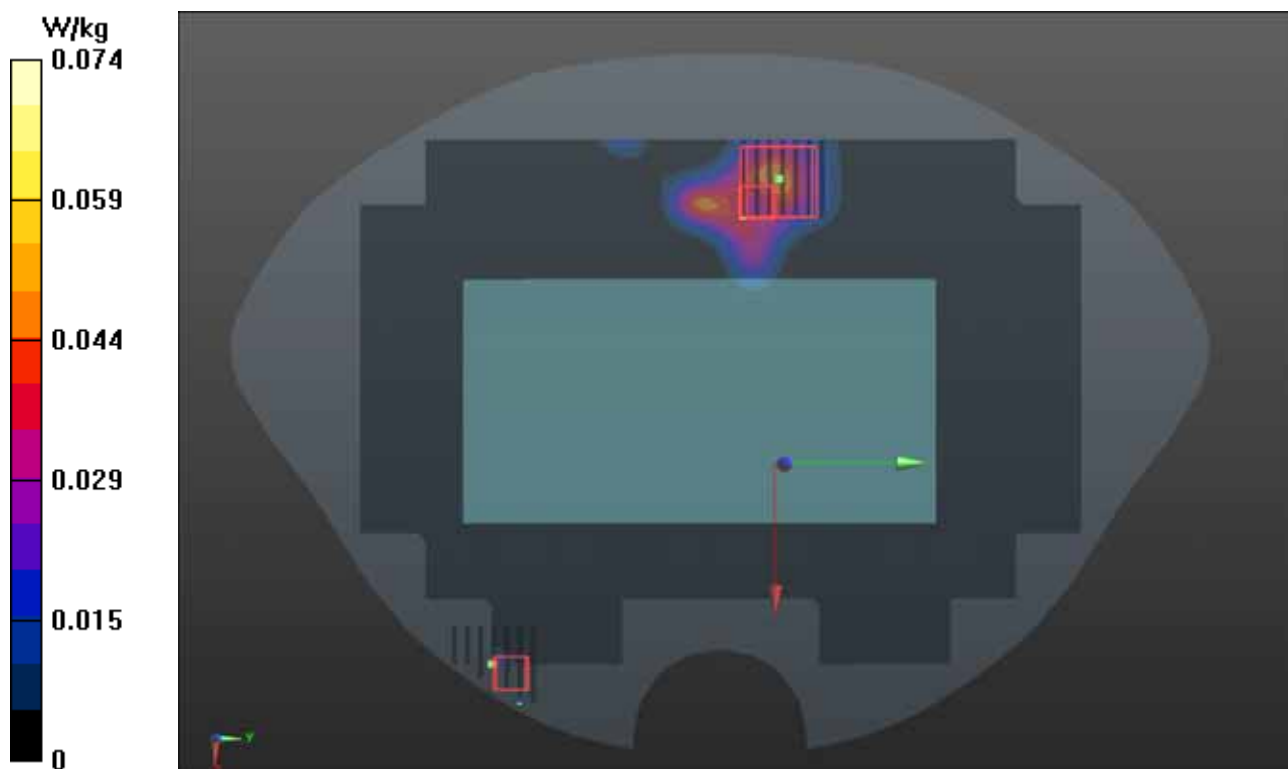

P97 802.11a_Front Face_1.5cm_Ch64_w MSR_ANT 1_Earphone_w_o Holster

DUT: 120703C13

Communication System: WLAN_5G; Frequency: 5320 MHz; Duty Cycle: 1:1

Medium: B5G_0823 Medium parameters used: $f = 5320$ MHz; $\sigma = 5.428$ mho/m; $\epsilon_r = 48.934$; $\rho = 1000$ kg/m³

Ambient Temperature : 21.7 °C ; Liquid Temperature : 20.6 °C

DASY5 Configuration:

- Probe: EX3DV4 - SN3590; ConvF(4.81, 4.81, 4.81); Calibrated: 2012/02/23;
- Sensor-Surface: 2mm (Mechanical Surface Detection)
- Electronics: DAE3 Sn579; Calibrated: 2012/04/27
- Phantom: SAM with CRP v5.0 Front; Type: QD000P40CD; Serial: TP:1653
- Measurement SW: DASY52, Version 52.8 (2); SEMCAD X Version 14.6.6 (6824)

Ch64/Area Scan (161x221x1): Measurement grid: dx=10mm, dy=10mm

Maximum value of SAR (interpolated) = 0.0752 W/kg

Ch64/Zoom Scan (7x7x9)/Cube 0: Measurement grid: dx=4mm, dy=4mm, dz=2.5mm

Reference Value = 0 V/m; Power Drift = 0.04 dB

Peak SAR (extrapolated) = 0.204 mW/g

SAR(1 g) = 0.020 mW/g; SAR(10 g) = 0.00495 mW/g

Maximum value of SAR (measured) = 0.180 W/kg

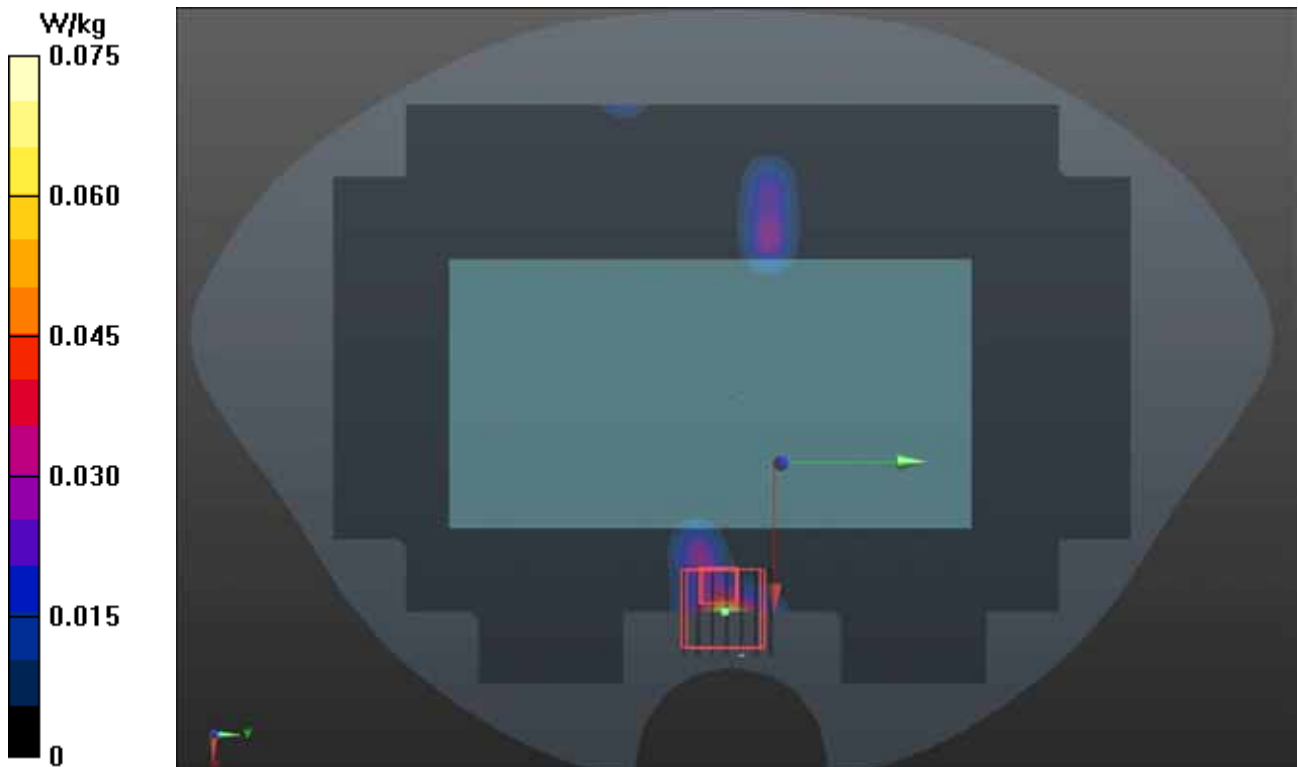

P98 802.11a_Rear Face_1.5cm_Ch64_w MSR_ANT 1_Earphone_w_o Holster

DUT: 120703C13

Communication System: WLAN_5G; Frequency: 5320 MHz; Duty Cycle: 1:1

Medium: B5G_0823 Medium parameters used: $f = 5320$ MHz; $\sigma = 5.428$ mho/m; $\epsilon_r = 48.934$; $\rho = 1000$ kg/m³

Ambient Temperature : 21.7 °C ; Liquid Temperature : 20.6 °C

DASY5 Configuration:

- Probe: EX3DV4 - SN3590; ConvF(4.81, 4.81, 4.81); Calibrated: 2012/02/23;
- Sensor-Surface: 2mm (Mechanical Surface Detection)
- Electronics: DAE3 Sn579; Calibrated: 2012/04/27
- Phantom: SAM with CRP v5.0 Front; Type: QD000P40CD; Serial: TP:1653
- Measurement SW: DASY52, Version 52.8 (2); SEMCAD X Version 14.6.6 (6824)

Ch64/Area Scan (161x221x1): Measurement grid: dx=10mm, dy=10mm

Maximum value of SAR (interpolated) = 0.397 W/kg

Ch64/Zoom Scan (7x7x9)/Cube 0: Measurement grid: dx=4mm, dy=4mm, dz=2.5mm

Reference Value = 3.800 V/m; Power Drift = -0.16 dB

Peak SAR (extrapolated) = 0.693 mW/g

SAR(1 g) = 0.197 mW/g; SAR(10 g) = 0.076 mW/g

Maximum value of SAR (measured) = 0.365 W/kg

Ch64/Zoom Scan (7x7x9)/Cube 1: Measurement grid: dx=4mm, dy=4mm, dz=2.5mm

Reference Value = 3.800 V/m; Power Drift = -0.16 dB

Peak SAR (extrapolated) = 0.538 mW/g

SAR(1 g) = 0.162 mW/g; SAR(10 g) = 0.066 mW/g

Maximum value of SAR (measured) = 0.298 W/kg

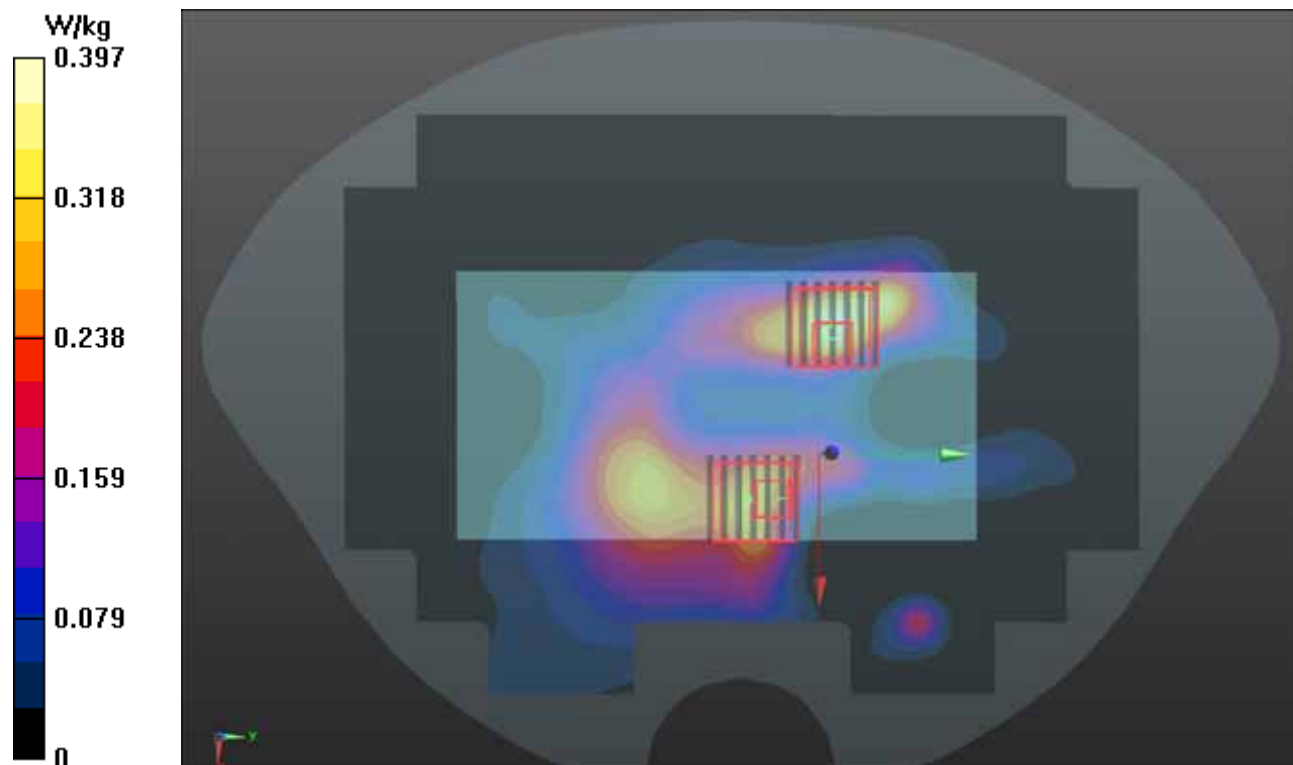

P100 802.11a_Front Face_0cm_Ch64_w_o MSR_ANT 0_w_o Earphone_w Holster

DUT: 120703C13

Communication System: WLAN_5G; Frequency: 5320 MHz; Duty Cycle: 1:1

Medium: B5G_0823 Medium parameters used: $f = 5320$ MHz; $\sigma = 5.428$ mho/m; $\epsilon_r = 48.934$; $\rho = 1000$ kg/m³

Ambient Temperature : 21.7 °C ; Liquid Temperature : 20.6 °C

DASY5 Configuration:

- Probe: EX3DV4 - SN3590; ConvF(4.81, 4.81, 4.81); Calibrated: 2012/02/23;
- Sensor-Surface: 2mm (Mechanical Surface Detection)
- Electronics: DAE3 Sn579; Calibrated: 2012/04/27
- Phantom: SAM with CRP v5.0 Front; Type: QD000P40CD; Serial: TP:1653
- Measurement SW: DASY52, Version 52.8 (2); SEMCAD X Version 14.6.6 (6824)

Ch64/Area Scan (161x221x1): Measurement grid: dx=10mm, dy=10mm

Maximum value of SAR (interpolated) = 0.0431 W/kg

Ch64/Zoom Scan (7x7x9)/Cube 0: Measurement grid: dx=4mm, dy=4mm, dz=2.5mm

Reference Value = 0.364 V/m; Power Drift = 0.14 dB

Peak SAR (extrapolated) = 0.154 mW/g

SAR(1 g) = 0.015 mW/g; SAR(10 g) = 0.00592 mW/g

Maximum value of SAR (measured) = 0.0279 W/kg

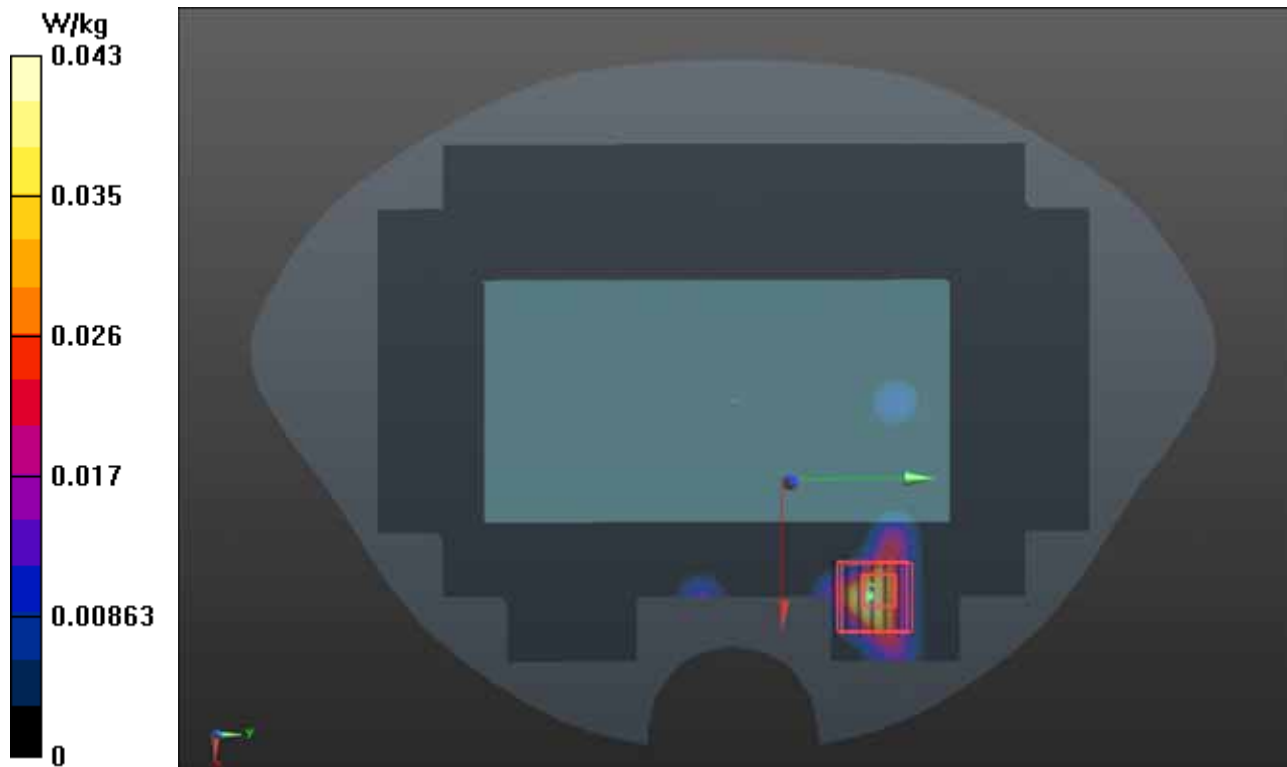

P101 802.11a_Rear Face_0cm_Ch64_w_o MSR_ANT 0_w_o Earphone_w Holster

DUT: 120703C13

Communication System: WLAN_5G; Frequency: 5320 MHz; Duty Cycle: 1:1

Medium: B5G_0823 Medium parameters used: $f = 5320$ MHz; $\sigma = 5.428$ mho/m; $\epsilon_r = 48.934$; $\rho = 1000$ kg/m³

Ambient Temperature : 21.7 °C ; Liquid Temperature : 20.6 °C

DASY5 Configuration:

- Probe: EX3DV4 - SN3590; ConvF(4.81, 4.81, 4.81); Calibrated: 2012/02/23;
- Sensor-Surface: 2mm (Mechanical Surface Detection)
- Electronics: DAE3 Sn579; Calibrated: 2012/04/27
- Phantom: SAM with CRP v5.0 Front; Type: QD000P40CD; Serial: TP:1653
- Measurement SW: DASY52, Version 52.8 (2); SEMCAD X Version 14.6.6 (6824)

Ch64/Area Scan (161x221x1): Measurement grid: dx=10mm, dy=10mm

Maximum value of SAR (interpolated) = 0.369 W/kg

Ch64/Zoom Scan (7x7x9)/Cube 0: Measurement grid: dx=4mm, dy=4mm, dz=2.5mm

Reference Value = 4.670 V/m; Power Drift = -0.04 dB

Peak SAR (extrapolated) = 0.581 mW/g

SAR(1 g) = 0.122 mW/g; SAR(10 g) = 0.042 mW/g

Maximum value of SAR (measured) = 0.379 W/kg

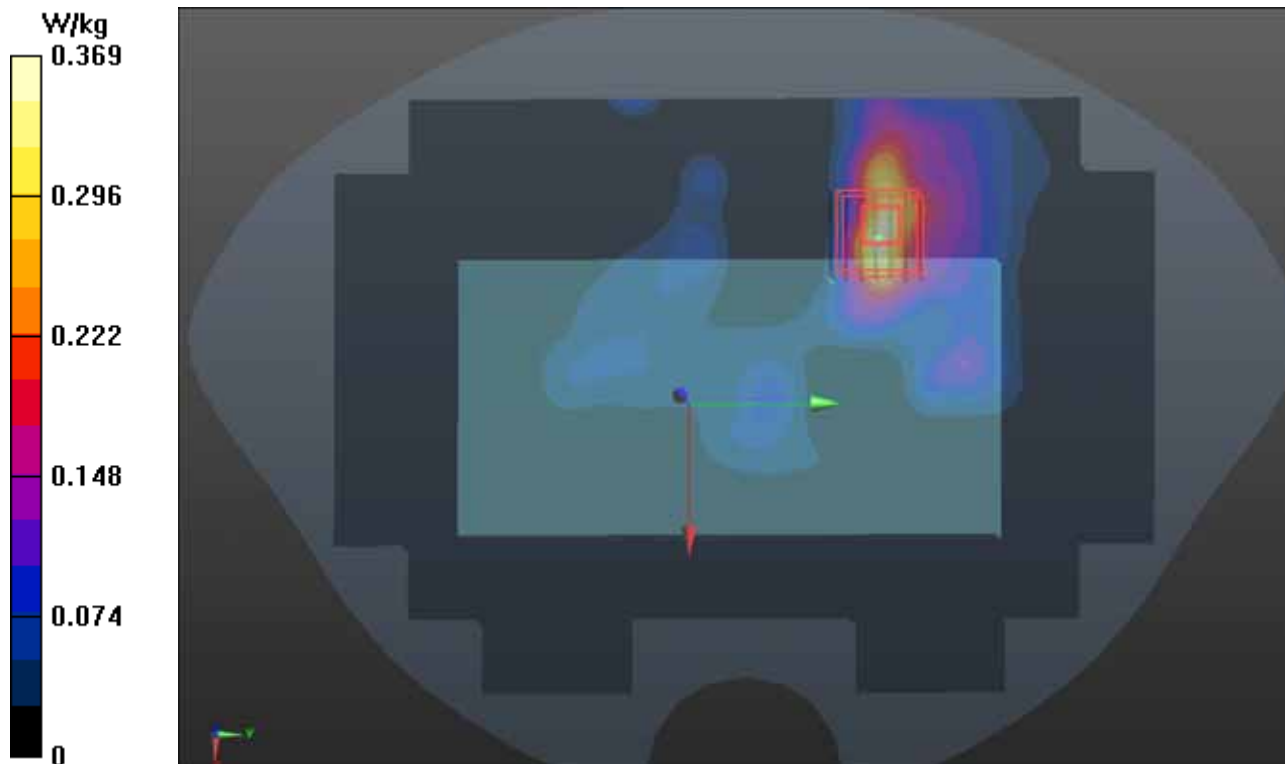

P103 802.11a_Front Face_1.5cm_Ch116_w_o MSR_ANT 0_w Earphone_w_o Holster

DUT: 120703C13

Communication System: WLAN_5G; Frequency: 5580 MHz; Duty Cycle: 1:1

Medium: B5G_0824 Medium parameters used: $f = 5580$ MHz; $\sigma = 5.818$ mho/m; $\epsilon_r = 48.209$; $\rho = 1000$ kg/m³

Ambient Temperature : 21.5 °C ; Liquid Temperature : 20.4 °C

DASY5 Configuration:

- Probe: EX3DV4 - SN3590; ConvF(3.92, 3.92, 3.92); Calibrated: 2012/02/23;
- Sensor-Surface: 2mm (Mechanical Surface Detection)
- Electronics: DAE3 Sn579; Calibrated: 2012/04/27
- Phantom: SAM with CRP v5.0 Front; Type: QD000P40CD; Serial: TP:1653
- Measurement SW: DASY52, Version 52.8 (2); SEMCAD X Version 14.6.6 (6824)

Ch116/Area Scan (161x221x1): Measurement grid: dx=10mm, dy=10mm

Maximum value of SAR (interpolated) = 0.200 W/kg

Ch116/Zoom Scan (7x7x9)/Cube 0: Measurement grid: dx=4mm, dy=4mm, dz=2.5mm

Reference Value = 0 V/m; Power Drift = 0.01 dB

Peak SAR (extrapolated) = 0.265 mW/g

SAR(1 g) = 0.041 mW/g; SAR(10 g) = 0.017 mW/g

Maximum value of SAR (measured) = 0.242 W/kg

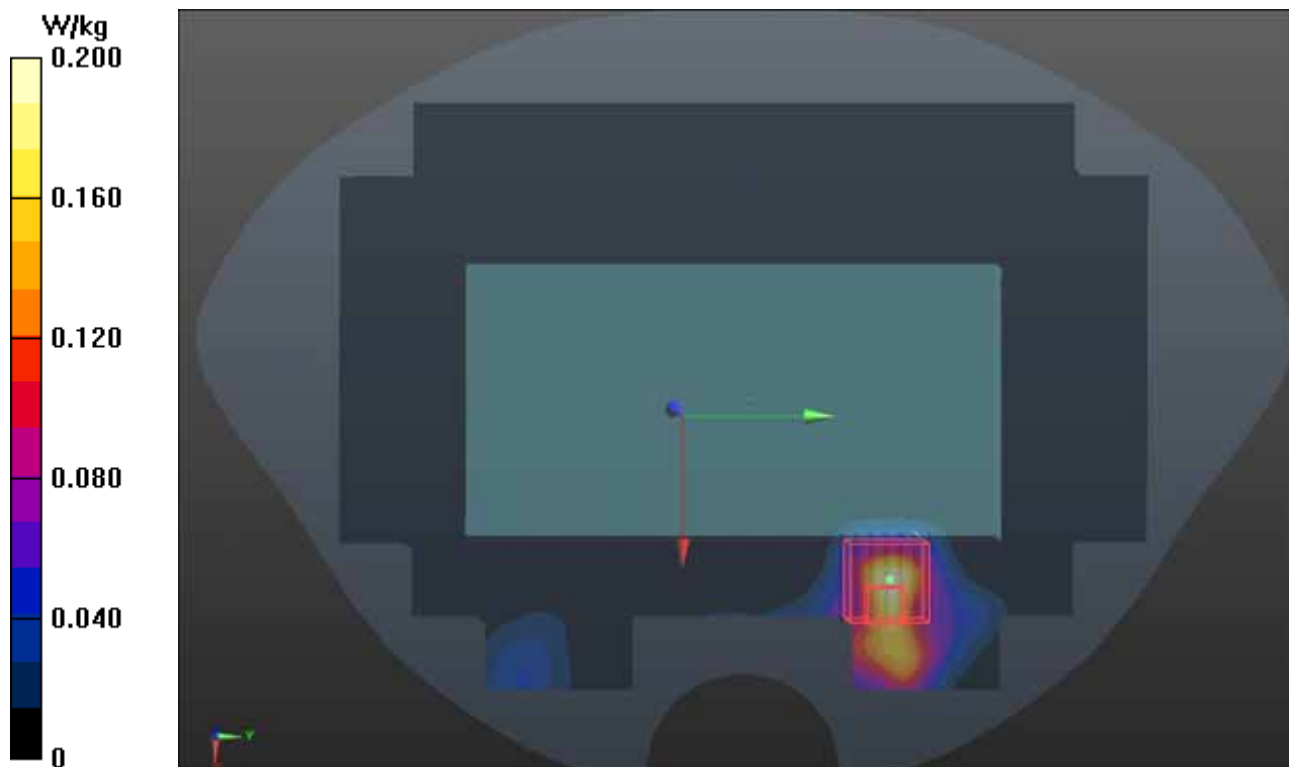

P104 802.11a_Front Face_1.5cm_Ch104_w MSR_ANT 0_w Earphone_w_o Holster

DUT: 120703C13

Communication System: WLAN_5G; Frequency: 5520 MHz; Duty Cycle: 1:1

Medium: B5G_0824 Medium parameters used: $f = 5520$ MHz; $\sigma = 5.697$ mho/m; $\epsilon_r = 48.465$; $\rho = 1000$ kg/m³

Ambient Temperature : 21.5 °C ; Liquid Temperature : 20.4 °C

DASY5 Configuration:

- Probe: EX3DV4 - SN3590; ConvF(4.35, 4.35, 4.35); Calibrated: 2012/02/23;
- Sensor-Surface: 2mm (Mechanical Surface Detection)
- Electronics: DAE3 Sn579; Calibrated: 2012/04/27
- Phantom: SAM with CRP v5.0 Front; Type: QD000P40CD; Serial: TP:1653
- Measurement SW: DASY52, Version 52.8 (2); SEMCAD X Version 14.6.6 (6824)

Ch104/Area Scan (161x221x1): Measurement grid: dx=10mm, dy=10mm

Maximum value of SAR (interpolated) = 0.0137 W/kg

Ch104/Zoom Scan (7x7x9)/Cube 0: Measurement grid: dx=4mm, dy=4mm, dz=2.5mm

Reference Value = 0 V/m; Power Drift = 0.05 dB

Peak SAR (extrapolated) = 0.357 mW/g

SAR(1 g) = 0.000963 mW/g; SAR(10 g) = 0.000182 mW/g

Maximum value of SAR (measured) = 0.357 W/kg

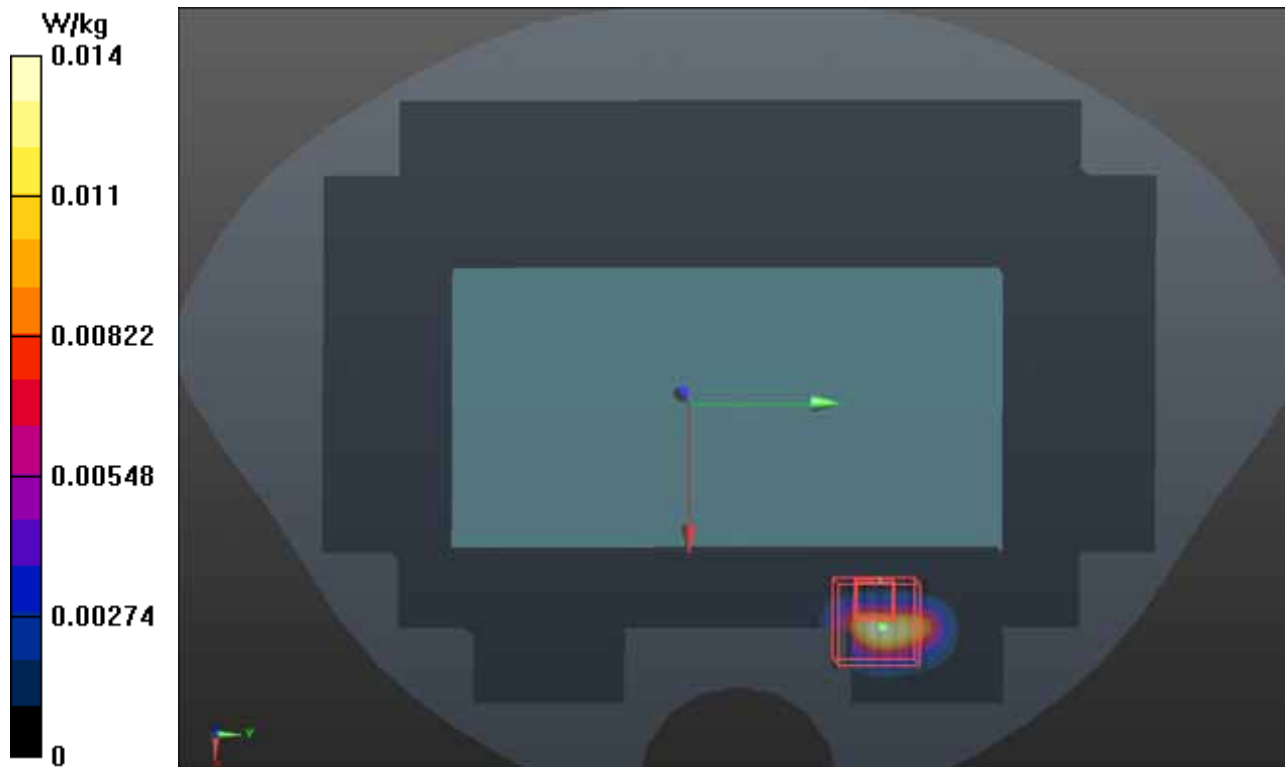

P105 802.11a_Rear Face_1.5cm_Ch116_w_o MSR_ANT 0_w Earphone_w_o Holster

DUT: 120703C13

Communication System: WLAN_5G; Frequency: 5580 MHz; Duty Cycle: 1:1

Medium: B5G_0824 Medium parameters used: $f = 5580$ MHz; $\sigma = 5.818$ mho/m; $\epsilon_r = 48.209$; $\rho = 1000$ kg/m³

Ambient Temperature : 21.5 °C ; Liquid Temperature : 20.4 °C

DASY5 Configuration:

- Probe: EX3DV4 - SN3590; ConvF(3.92, 3.92, 3.92); Calibrated: 2012/02/23;
- Sensor-Surface: 2mm (Mechanical Surface Detection)
- Electronics: DAE3 Sn579; Calibrated: 2012/04/27
- Phantom: SAM with CRP v5.0 Front; Type: QD000P40CD; Serial: TP:1653
- Measurement SW: DASY52, Version 52.8 (2); SEMCAD X Version 14.6.6 (6824)

Ch116/Area Scan (161x221x1): Measurement grid: dx=10mm, dy=10mm

Maximum value of SAR (interpolated) = 1.30 W/kg

Ch116/Zoom Scan (7x7x9)/Cube 0: Measurement grid: dx=4mm, dy=4mm, dz=2.5mm

Reference Value = 5.775 V/m; Power Drift = -0.07 dB

Peak SAR (extrapolated) = 3.556 mW/g

SAR(1 g) = 0.663 mW/g; SAR(10 g) = 0.275 mW/g

Maximum value of SAR (measured) = 1.22 W/kg

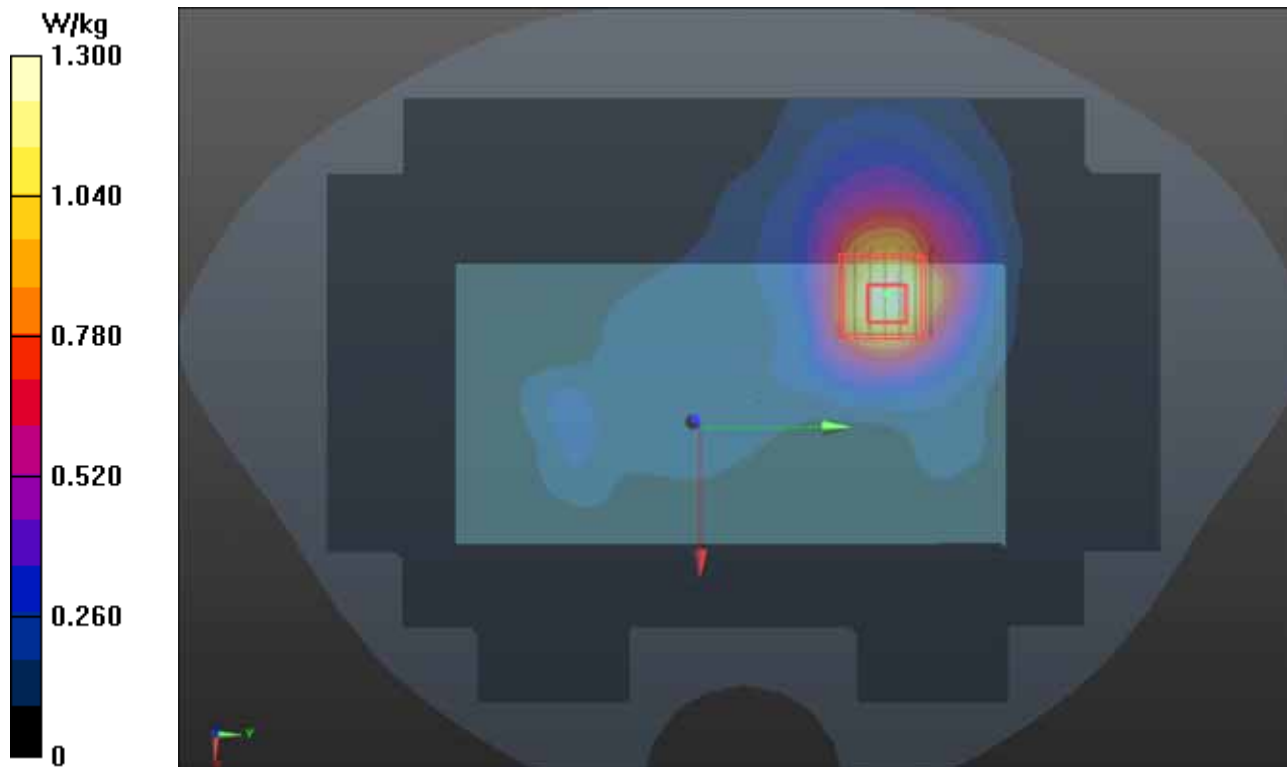

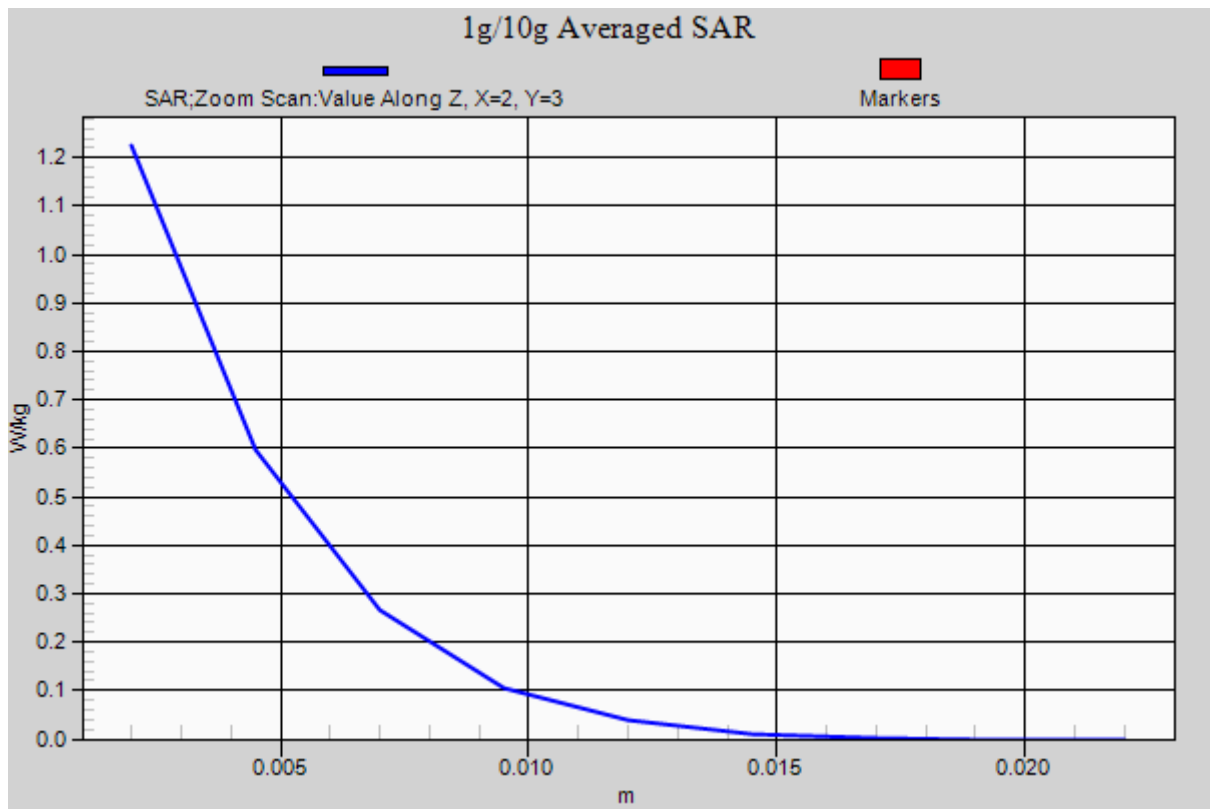

P108 802.11a_Front Face_1.5cm_Ch116_w_o MSR_ANT 1_w Earphone_w_o Holster

DUT: 120703C13

Communication System: WLAN_5G; Frequency: 5580 MHz; Duty Cycle: 1:1

Medium: B5G_0824 Medium parameters used: $f = 5580$ MHz; $\sigma = 5.818$ mho/m; $\epsilon_r = 48.209$; $\rho = 1000$ kg/m³

Ambient Temperature : 21.5 °C ; Liquid Temperature : 20.4 °C

DASY5 Configuration:

- Probe: EX3DV4 - SN3590; ConvF(3.92, 3.92, 3.92); Calibrated: 2012/02/23;
- Sensor-Surface: 2mm (Mechanical Surface Detection)
- Electronics: DAE3 Sn579; Calibrated: 2012/04/27
- Phantom: SAM with CRP v5.0 Front; Type: QD000P40CD; Serial: TP:1653
- Measurement SW: DASY52, Version 52.8 (2); SEMCAD X Version 14.6.6 (6824)

Ch116/Area Scan (161x221x1): Measurement grid: dx=10mm, dy=10mm

Maximum value of SAR (interpolated) = 0.0735 W/kg

Ch116/Zoom Scan (7x7x9)/Cube 0: Measurement grid: dx=4mm, dy=4mm, dz=2.5mm

Reference Value = 0 V/m; Power Drift = 0.05 dB

Peak SAR (extrapolated) = 0.146 mW/g

SAR(1 g) = 0.00673 mW/g; SAR(10 g) = 0.000726 mW/g

Maximum value of SAR (measured) = 0.0263 W/kg

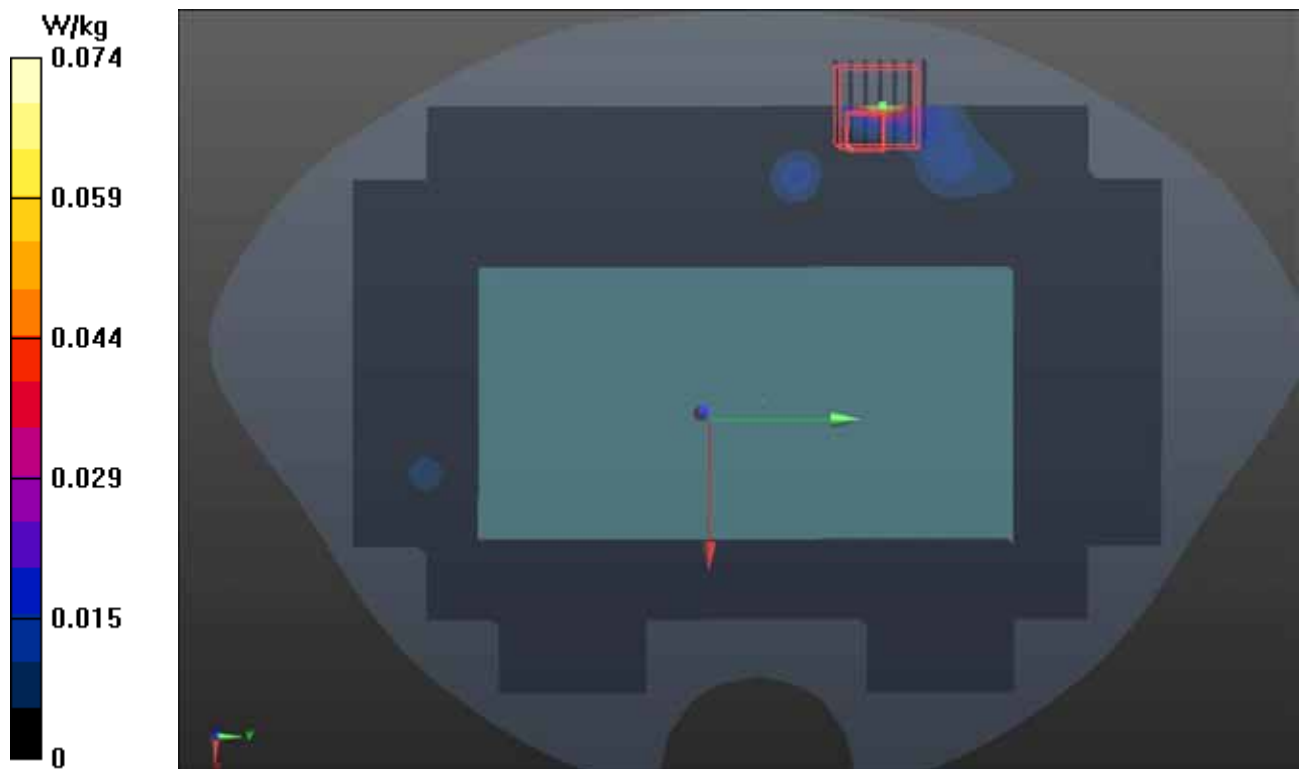

P109 802.11a_Front Face_1.5cm_Ch116_w MSR_ANT 1_w Earphone_w_o Holster

DUT: 120703C13

Communication System: WLAN_5G; Frequency: 5580 MHz; Duty Cycle: 1:1

Medium: B5G_0824 Medium parameters used: $f = 5580$ MHz; $\sigma = 5.818$ mho/m; $\epsilon_r = 48.209$; $\rho = 1000$ kg/m³

Ambient Temperature : 21.5 °C ; Liquid Temperature : 20.4 °C

DASY5 Configuration:

- Probe: EX3DV4 - SN3590; ConvF(3.92, 3.92, 3.92); Calibrated: 2012/02/23;
- Sensor-Surface: 2mm (Mechanical Surface Detection)
- Electronics: DAE3 Sn579; Calibrated: 2012/04/27
- Phantom: SAM with CRP v5.0 Front; Type: QD000P40CD; Serial: TP:1653
- Measurement SW: DASY52, Version 52.8 (2); SEMCAD X Version 14.6.6 (6824)

Ch116/Area Scan (161x221x1): Measurement grid: dx=10mm, dy=10mm

Maximum value of SAR (interpolated) = 0.0342 W/kg

Ch116/Zoom Scan (7x7x9)/Cube 0: Measurement grid: dx=4mm, dy=4mm, dz=2.5mm

Reference Value = 0 V/m; Power Drift = 0.05 dB

Peak SAR (extrapolated) = 0.142 mW/g

SAR(1 g) = 0.012 mW/g; SAR(10 g) = 0.00216 mW/g

Maximum value of SAR (measured) = 0.0228 W/kg

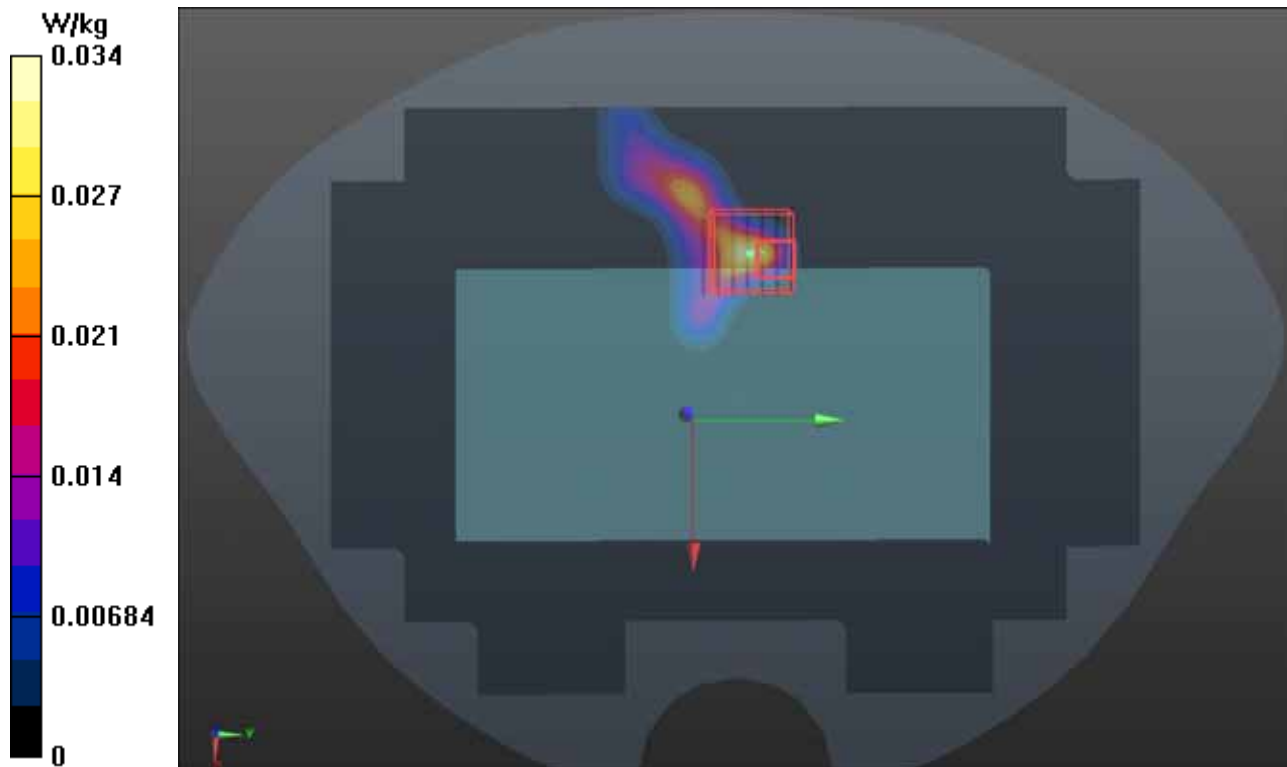

P110 802.11a_Rear Face_1.5cm_Ch116_w MSR_ANT 1_w Earphone_w_o Holster

DUT: 120703C13

Communication System: WLAN_5G; Frequency: 5580 MHz; Duty Cycle: 1:1

Medium: B5G_0824 Medium parameters used: $f = 5580$ MHz; $\sigma = 5.818$ mho/m; $\epsilon_r = 48.209$; $\rho = 1000$ kg/m³

Ambient Temperature : 21.5 °C ; Liquid Temperature : 20.4 °C

DASY5 Configuration:

- Probe: EX3DV4 - SN3590; ConvF(3.92, 3.92, 3.92); Calibrated: 2012/02/23;
- Sensor-Surface: 2mm (Mechanical Surface Detection)
- Electronics: DAE3 Sn579; Calibrated: 2012/04/27
- Phantom: SAM with CRP v5.0 Front; Type: QD000P40CD; Serial: TP:1653
- Measurement SW: DASY52, Version 52.8 (2); SEMCAD X Version 14.6.6 (6824)

Ch116/Area Scan (161x221x1): Measurement grid: dx=10mm, dy=10mm

Maximum value of SAR (interpolated) = 0.758 W/kg

Ch116/Zoom Scan (7x7x9)/Cube 0: Measurement grid: dx=4mm, dy=4mm, dz=2.5mm

Reference Value = 6.136 V/m; Power Drift = -0.11 dB

Peak SAR (extrapolated) = 5.005 mW/g

SAR(1 g) = 0.512 mW/g; SAR(10 g) = 0.210 mW/g

Maximum value of SAR (measured) = 0.798 W/kg

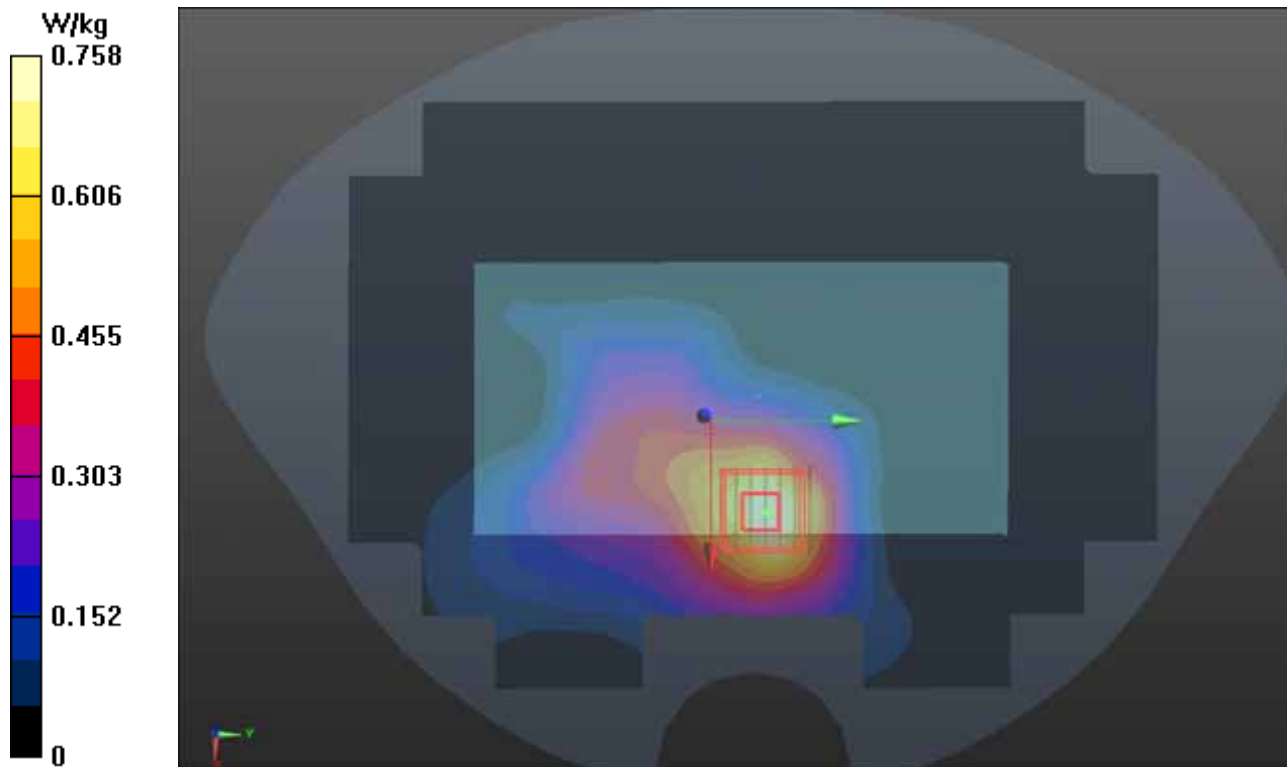

P113 802.11a_Front Face_0cm_Ch116_w_o MSR_ANT 0_w_o Earphone_w Holster

DUT: 120703C13

Communication System: WLAN_5G; Frequency: 5580 MHz; Duty Cycle: 1:1

Medium: B5G_0824 Medium parameters used: $f = 5580$ MHz; $\sigma = 5.818$ mho/m; $\epsilon_r = 48.209$; $\rho = 1000$ kg/m³

Ambient Temperature : 21.5 °C ; Liquid Temperature : 20.4 °C

DASY5 Configuration:

- Probe: EX3DV4 - SN3590; ConvF(3.92, 3.92, 3.92); Calibrated: 2012/02/23;
- Sensor-Surface: 2mm (Mechanical Surface Detection)
- Electronics: DAE3 Sn579; Calibrated: 2012/04/27
- Phantom: SAM with CRP v5.0 Front; Type: QD000P40CD; Serial: TP:1653
- Measurement SW: DASY52, Version 52.8 (2); SEMCAD X Version 14.6.6 (6824)

Ch116/Area Scan (161x221x1): Measurement grid: dx=10mm, dy=10mm

Maximum value of SAR (interpolated) = 0.361 W/kg

Ch116/Zoom Scan (7x7x9)/Cube 0: Measurement grid: dx=4mm, dy=4mm, dz=2.5mm

Reference Value = 0.957 V/m; Power Drift = -0.10 dB

Peak SAR (extrapolated) = 0.138 mW/g

SAR(1 g) = 0.014 mW/g; SAR(10 g) = 0.00415 mW/g

Maximum value of SAR (measured) = 0.0271 W/kg

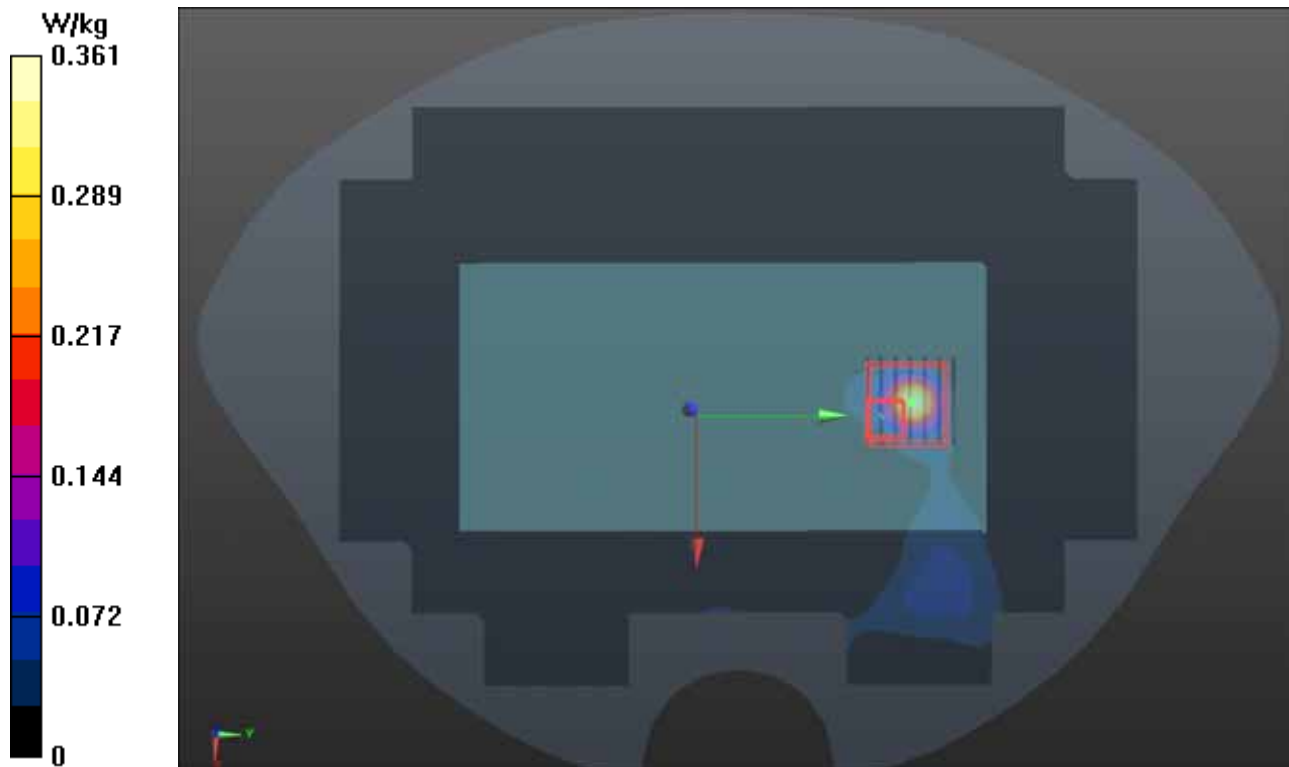

P114 802.11a_Rear Face_0cm_Ch116_w_o MSR_ANT 0_w_o Earphone_w Holster

DUT: 120703C13

Communication System: WLAN_5G; Frequency: 5580 MHz; Duty Cycle: 1:1

Medium: B5G_0824 Medium parameters used: $f = 5580$ MHz; $\sigma = 5.818$ mho/m; $\epsilon_r = 48.209$; $\rho = 1000$ kg/m³

Ambient Temperature : 21.5 °C ; Liquid Temperature : 20.4 °C

DASY5 Configuration:

- Probe: EX3DV4 - SN3590; ConvF(3.92, 3.92, 3.92); Calibrated: 2012/02/23;
- Sensor-Surface: 2mm (Mechanical Surface Detection)
- Electronics: DAE3 Sn579; Calibrated: 2012/04/27
- Phantom: SAM with CRP v5.0 Front; Type: QD000P40CD; Serial: TP:1653
- Measurement SW: DASY52, Version 52.8 (2); SEMCAD X Version 14.6.6 (6824)

Ch116/Area Scan (161x221x1): Measurement grid: dx=10mm, dy=10mm

Maximum value of SAR (interpolated) = 0.419 W/kg

Ch116/Zoom Scan (7x7x9)/Cube 0: Measurement grid: dx=4mm, dy=4mm, dz=2.5mm

Reference Value = 3.184 V/m; Power Drift = -0.08 dB

Peak SAR (extrapolated) = 0.670 mW/g

SAR(1 g) = 0.222 mW/g; SAR(10 g) = 0.093 mW/g

Maximum value of SAR (measured) = 0.415 W/kg

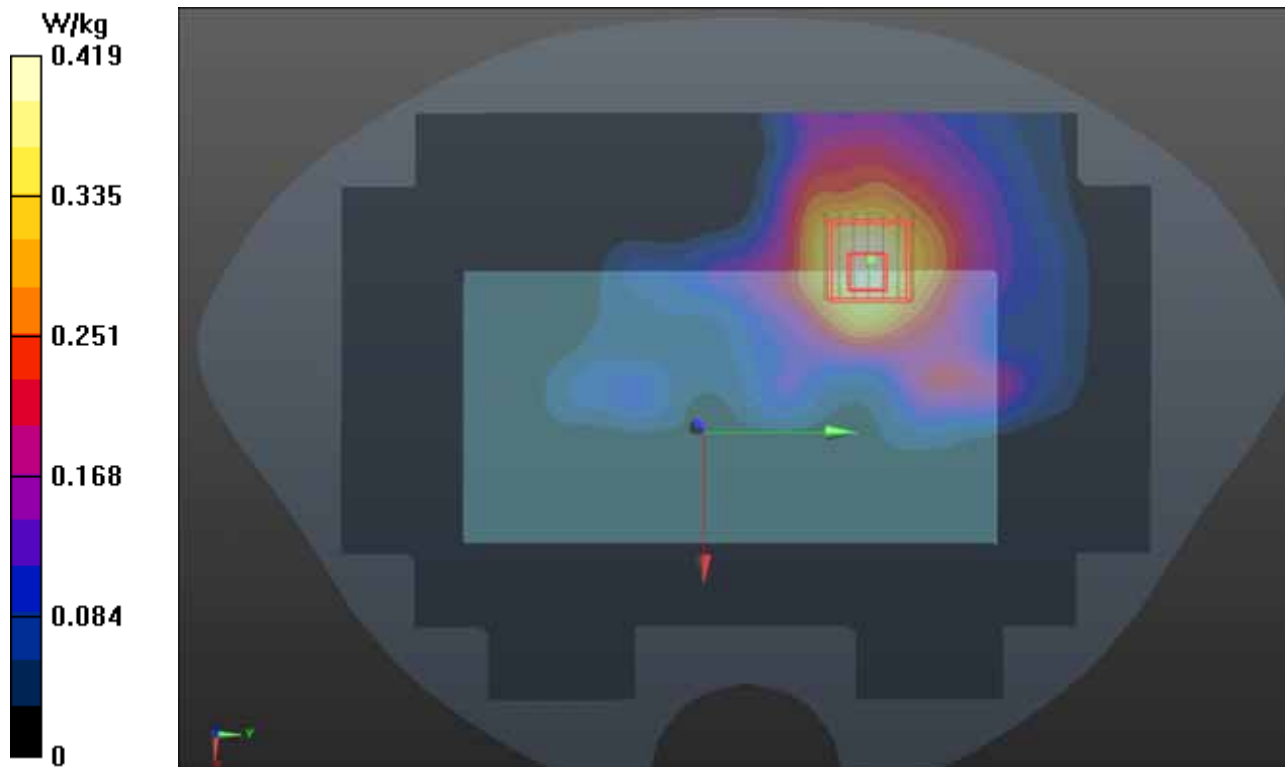

P117 802.11a_Front Face_1.5cm_Ch149_w_o MSR_ANT 0_w Earphone_w_o Holste

DUT: 120703C13

Communication System: WLAN_5G; Frequency: 5745 MHz; Duty Cycle: 1:1

Medium: B5G_0824 Medium parameters used: $f = 5745$ MHz; $\sigma = 6.019$ mho/m; $\epsilon_r = 48.128$; $\rho = 1000$ kg/m³

Ambient Temperature : 21.5 °C ; Liquid Temperature : 20.4 °C

DASY5 Configuration:

- Probe: EX3DV4 - SN3590; ConvF(4.54, 4.54, 4.54); Calibrated: 2012/02/23;
- Sensor-Surface: 2mm (Mechanical Surface Detection)
- Electronics: DAE3 Sn579; Calibrated: 2012/04/27
- Phantom: SAM with CRP v5.0 Front; Type: QD000P40CD; Serial: TP:1653
- Measurement SW: DASY52, Version 52.8 (2); SEMCAD X Version 14.6.6 (6824)

Ch149/Area Scan (161x221x1): Measurement grid: dx=10mm, dy=10mm

Maximum value of SAR (interpolated) = 0.0940 W/kg

Ch149/Zoom Scan (7x7x9)/Cube 0: Measurement grid: dx=4mm, dy=4mm, dz=2.5mm

Reference Value = 0 V/m; Power Drift = 0.01 dB

Peak SAR (extrapolated) = 0.170 mW/g

SAR(1 g) = 0.024 mW/g; SAR(10 g) = 0.00921 mW/g

Maximum value of SAR (measured) = 0.0829 W/kg

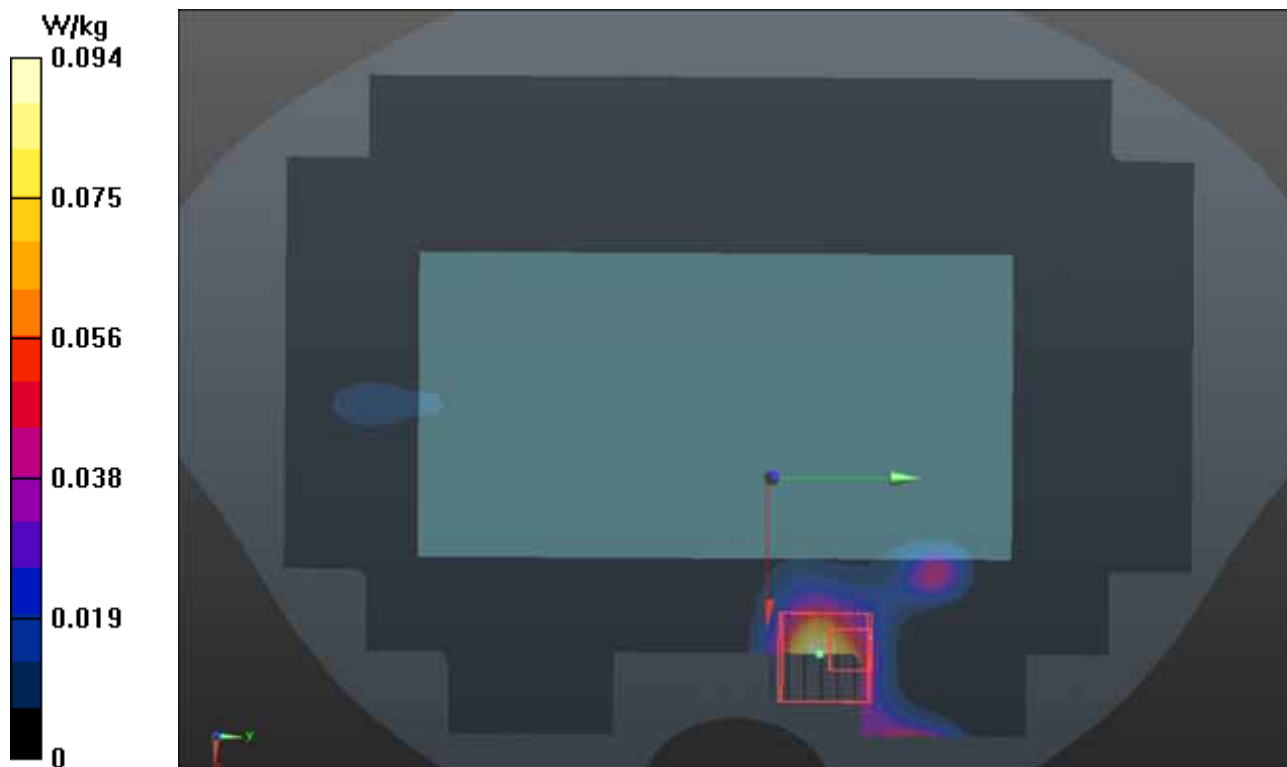

P118 802.11a_Front Face_1.5cm_Ch157_w MSR_ANT 0_w Earphone_w_o Holster

DUT: 120703C13

Communication System: WLAN_5G; Frequency: 5785 MHz; Duty Cycle: 1:1

Medium: B5G_0824 Medium parameters used: $f = 5785$ MHz; $\sigma = 6.066$ mho/m; $\epsilon_r = 47.849$; $\rho = 1000$ kg/m³

Ambient Temperature : 21.5 °C ; Liquid Temperature : 20.4 °C

DASY5 Configuration:

- Probe: EX3DV4 - SN3590; ConvF(4.54, 4.54, 4.54); Calibrated: 2012/02/23;
- Sensor-Surface: 2mm (Mechanical Surface Detection)
- Electronics: DAE3 Sn579; Calibrated: 2012/04/27
- Phantom: SAM with CRP v5.0 Front; Type: QD000P40CD; Serial: TP:1653
- Measurement SW: DASY52, Version 52.8 (2); SEMCAD X Version 14.6.6 (6824)

Ch157/Area Scan (161x221x1): Measurement grid: dx=10mm, dy=10mm

Maximum value of SAR (interpolated) = 0.0147 W/kg

Ch157/Zoom Scan (7x7x9)/Cube 0: Measurement grid: dx=4mm, dy=4mm, dz=2.5mm

Reference Value = 0 V/m; Power Drift = 0.07 dB

Peak SAR (extrapolated) = 0.022 mW/g

SAR(1 g) = 0.00185 mW/g; SAR(10 g) = 0.000189 mW/g

Maximum value of SAR (measured) = 0.0225 W/kg

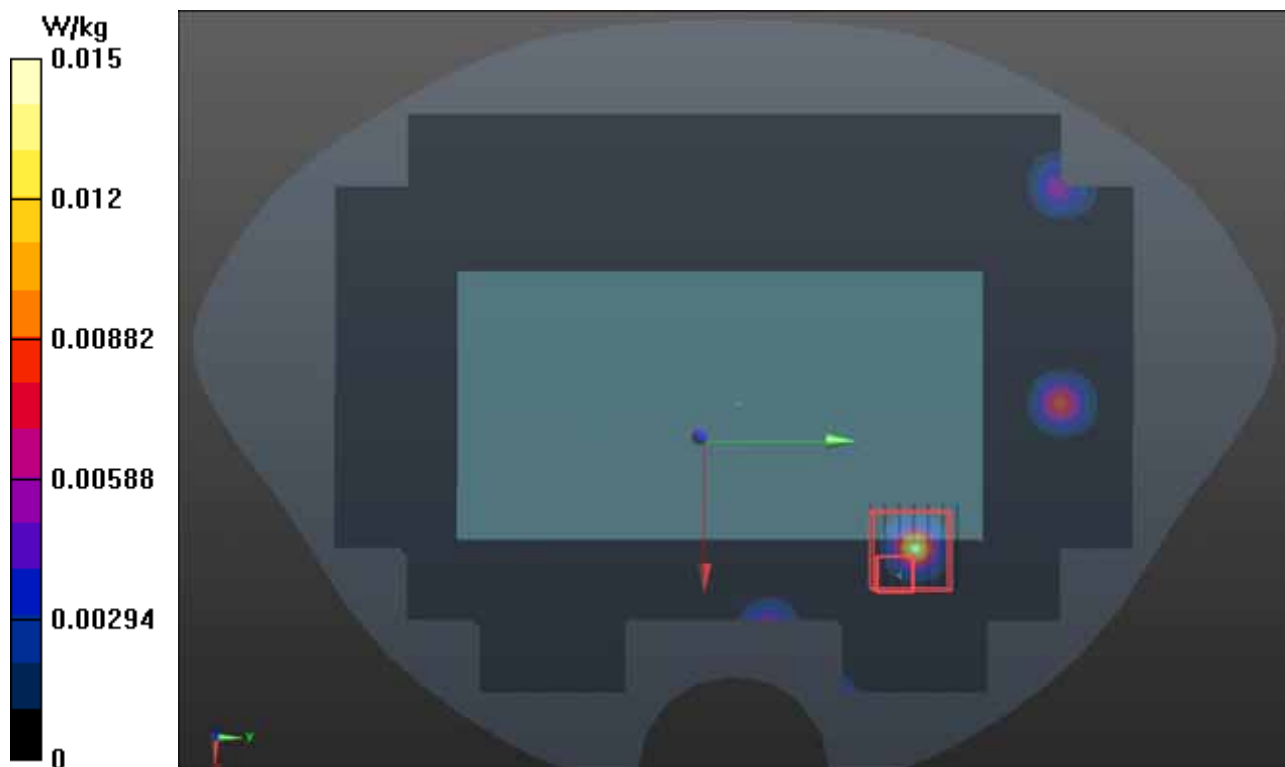

P119 802.11a_Rear Face_1.5cm_Ch149_w_o MSR_ANT 0_w Earphone_w_o Holste

DUT: 120703C13

Communication System: WLAN_5G; Frequency: 5745 MHz; Duty Cycle: 1:1

Medium: B5G_0824 Medium parameters used: $f = 5745$ MHz; $\sigma = 6.019$ mho/m; $\epsilon_r = 48.128$; $\rho = 1000$ kg/m³

Ambient Temperature : 21.5 °C ; Liquid Temperature : 20.4 °C

DASY5 Configuration:

- Probe: EX3DV4 - SN3590; ConvF(4.54, 4.54, 4.54); Calibrated: 2012/02/23;
- Sensor-Surface: 2mm (Mechanical Surface Detection)
- Electronics: DAE3 Sn579; Calibrated: 2012/04/27
- Phantom: SAM with CRP v5.0 Front; Type: QD000P40CD; Serial: TP:1653
- Measurement SW: DASY52, Version 52.8 (2); SEMCAD X Version 14.6.6 (6824)

Ch149/Area Scan (161x221x1): Measurement grid: dx=10mm, dy=10mm

Maximum value of SAR (interpolated) = 1.06 W/kg

Ch149/Zoom Scan (7x7x9)/Cube 0: Measurement grid: dx=4mm, dy=4mm, dz=2.5mm

Reference Value = 4.272 V/m; Power Drift = 0.08 dB

Peak SAR (extrapolated) = 1.772 mW/g

SAR(1 g) = 0.527 mW/g; SAR(10 g) = 0.215 mW/g

Maximum value of SAR (measured) = 0.982 W/kg

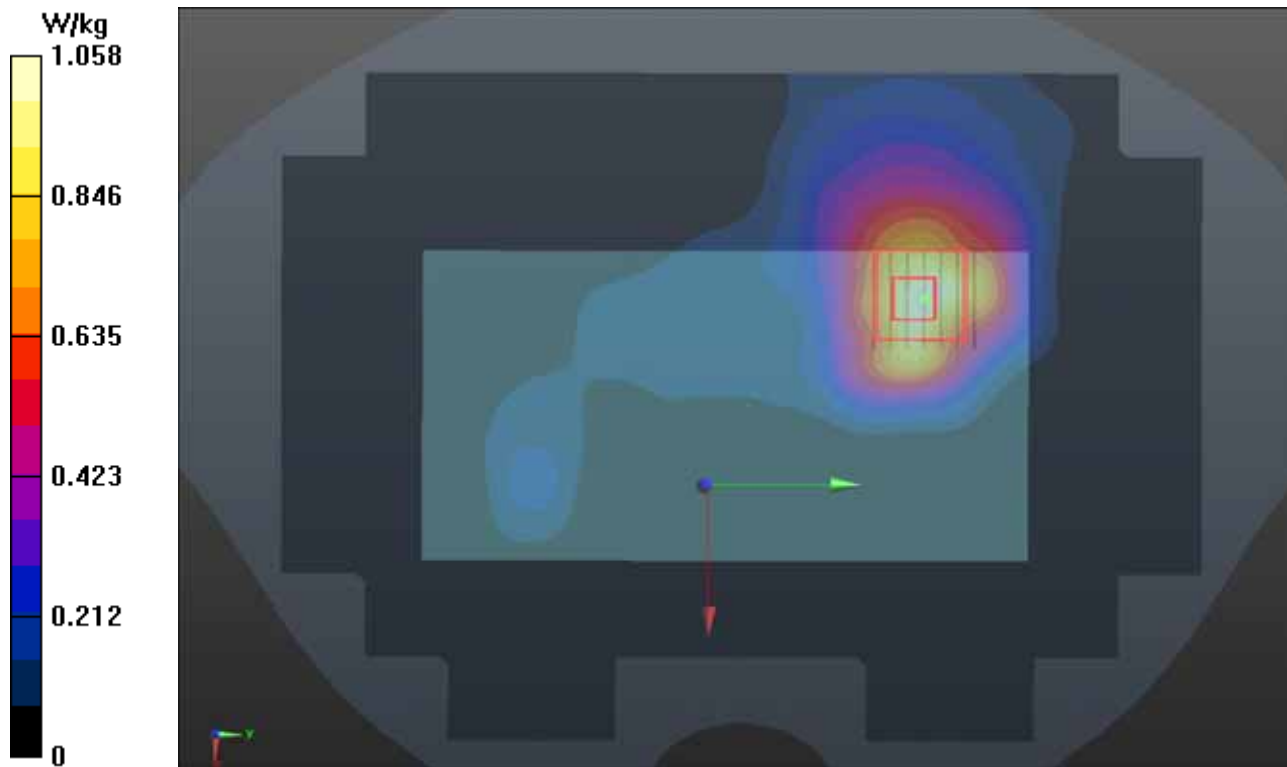

P122 802.11n_HT20_Front Face_1.5cm_Ch149_w_o MSR_ANT 1_w Earphone_w_o Holste

DUT: 120703C13

Communication System: WLAN_5G; Frequency: 5745 MHz; Duty Cycle: 1:1

Medium: B5G_0824 Medium parameters used: $f = 5745$ MHz; $\sigma = 6.019$ mho/m; $\epsilon_r = 48.128$; $\rho = 1000$ kg/m³

Ambient Temperature : 21.5 °C ; Liquid Temperature : 20.4 °C

DASY5 Configuration:

- Probe: EX3DV4 - SN3590; ConvF(4.54, 4.54, 4.54); Calibrated: 2012/02/23;
- Sensor-Surface: 2mm (Mechanical Surface Detection)
- Electronics: DAE3 Sn579; Calibrated: 2012/04/27
- Phantom: SAM with CRP v5.0 Front; Type: QD000P40CD; Serial: TP:1653
- Measurement SW: DASY52, Version 52.8 (2); SEMCAD X Version 14.6.6 (6824)

Ch149/Area Scan (161x221x1): Measurement grid: dx=10mm, dy=10mm

Maximum value of SAR (interpolated) = 0.119 W/kg

Ch149/Zoom Scan (7x7x9)/Cube 0: Measurement grid: dx=4mm, dy=4mm, dz=2.5mm

Reference Value = 0 V/m; Power Drift = 0.01 dB

Peak SAR (extrapolated) = 0.251 mW/g

SAR(1 g) = 0.035 mW/g; SAR(10 g) = 0.014 mW/g

Maximum value of SAR (measured) = 0.216 W/kg

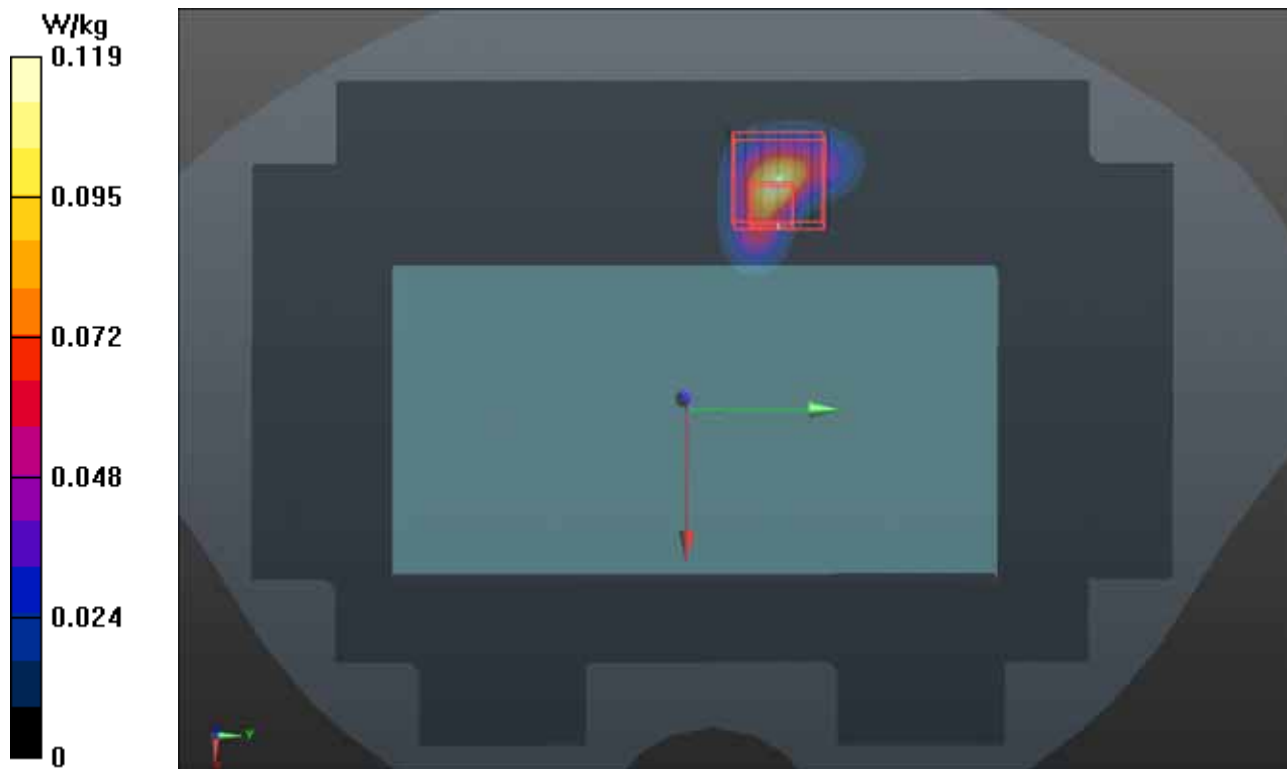

P123 802.11n_HT20_Front Face_1.5cm_Ch149_w_MSR_ANT 1_w Earphone_w_o Holste

DUT: 120703C13

Communication System: WLAN_5G; Frequency: 5745 MHz; Duty Cycle: 1:1

Medium: B5G_0824 Medium parameters used: $f = 5745$ MHz; $\sigma = 6.019$ mho/m; $\epsilon_r = 48.128$; $\rho = 1000$ kg/m³

Ambient Temperature : 21.5 °C ; Liquid Temperature : 20.4 °C

DASY5 Configuration:

- Probe: EX3DV4 - SN3590; ConvF(4.54, 4.54, 4.54); Calibrated: 2012/02/23;
- Sensor-Surface: 2mm (Mechanical Surface Detection)
- Electronics: DAE3 Sn579; Calibrated: 2012/04/27
- Phantom: SAM with CRP v5.0 Front; Type: QD000P40CD; Serial: TP:1653
- Measurement SW: DASY52, Version 52.8 (2); SEMCAD X Version 14.6.6 (6824)

Ch149/Area Scan (81x111x1): Measurement grid: dx=10mm, dy=10mm

Maximum value of SAR (interpolated) = 0.199 W/kg

Ch149/Zoom Scan (7x7x9)/Cube 0: Measurement grid: dx=4mm, dy=4mm, dz=2.5mm

Reference Value = 0.175 V/m; Power Drift = -0.001 dB

Peak SAR (extrapolated) = 0.806 mW/g

SAR(1 g) = 0.084 mW/g; SAR(10 g) = 0.025 mW/g

Maximum value of SAR (measured) = 0.796 W/kg

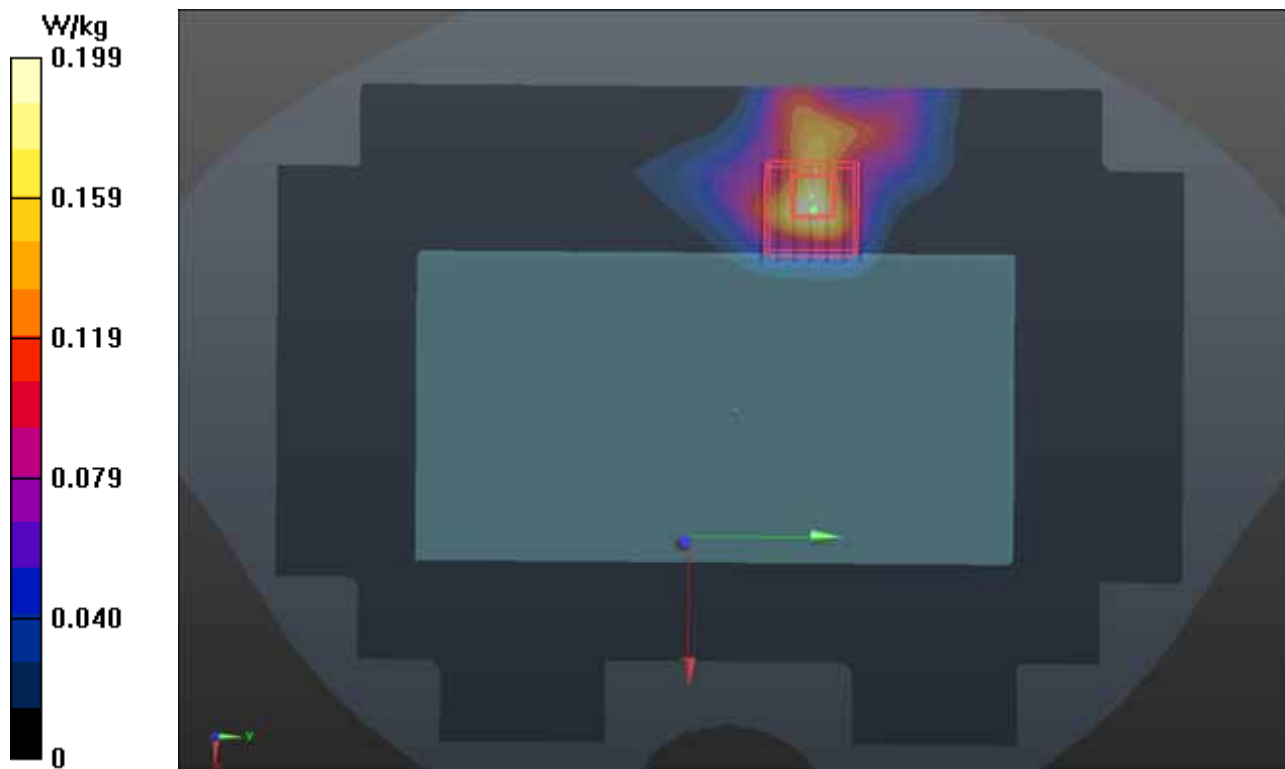

P124 802.11n_HT20_Rear Face_1.5cm_Ch149_w_MSR_ANT 1_w Earphone_w_o Holste

DUT: 120703C13

Communication System: WLAN_5G; Frequency: 5745 MHz; Duty Cycle: 1:1

Medium: B5G_0824 Medium parameters used: $f = 5745$ MHz; $\sigma = 6.019$ mho/m; $\epsilon_r = 48.128$; $\rho = 1000$ kg/m³

Ambient Temperature : 21.5 °C ; Liquid Temperature : 20.4 °C

DASY5 Configuration:

- Probe: EX3DV4 - SN3590; ConvF(4.54, 4.54, 4.54); Calibrated: 2012/02/23;
- Sensor-Surface: 2mm (Mechanical Surface Detection)
- Electronics: DAE3 Sn579; Calibrated: 2012/04/27
- Phantom: SAM with CRP v5.0 Front; Type: QD000P40CD; Serial: TP:1653
- Measurement SW: DASY52, Version 52.8 (2); SEMCAD X Version 14.6.6 (6824)

Ch149/Area Scan (161x221x1): Measurement grid: dx=10mm, dy=10mm

Maximum value of SAR (interpolated) = 1.05 W/kg

Ch149/Zoom Scan (7x7x9)/Cube 0: Measurement grid: dx=4mm, dy=4mm, dz=2.5mm

Reference Value = 3.188 V/m; Power Drift = -0.08 dB

Peak SAR (extrapolated) = 2.044 mW/g

SAR(1 g) = 0.564 mW/g; SAR(10 g) = 0.220 mW/g

Maximum value of SAR (measured) = 1.09 W/kg

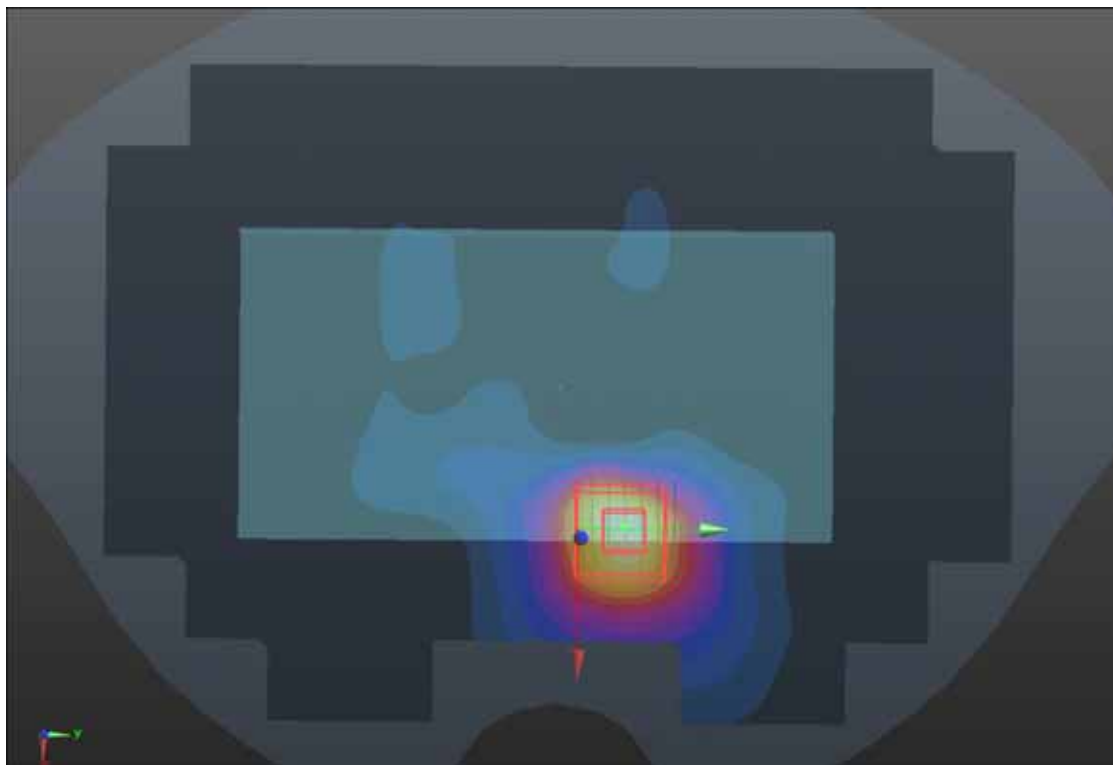
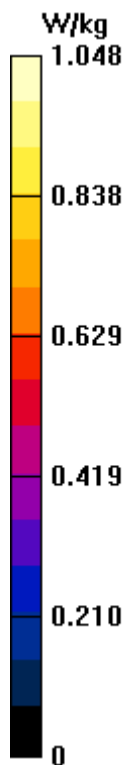

1g/10g Averaged SAR

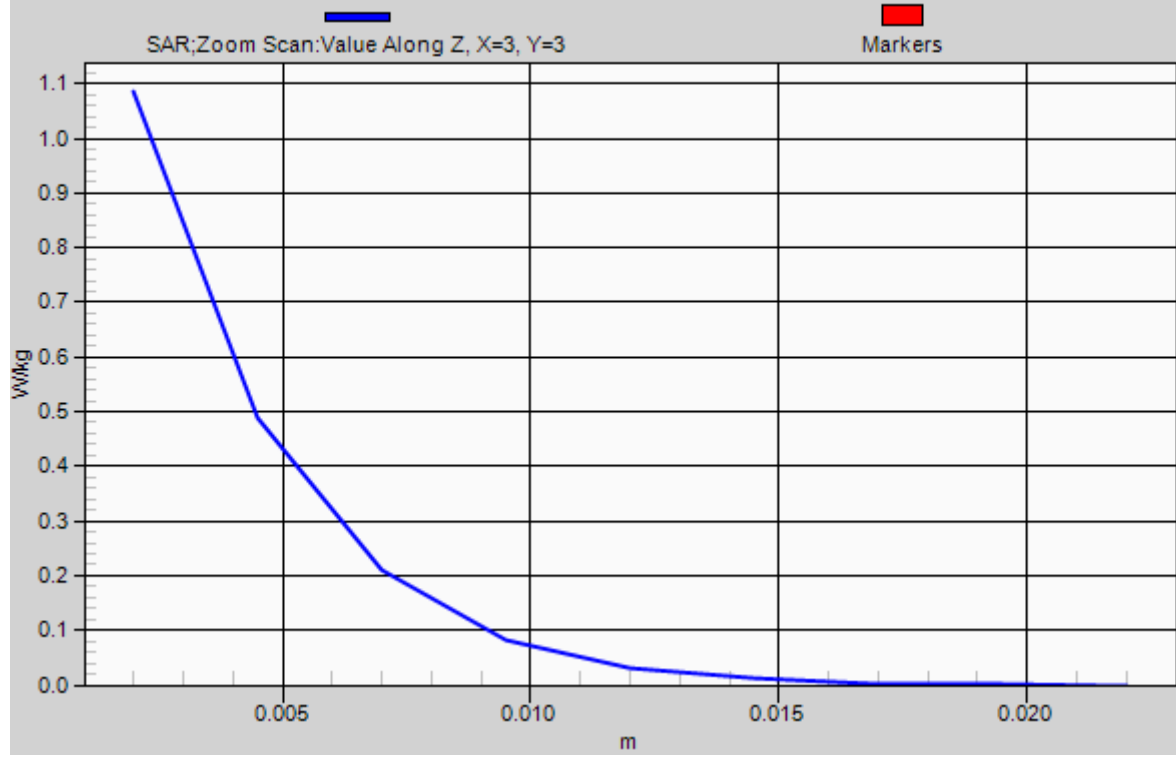

P127 802.11n_HT20_Front Face_0cm_Ch149_w_MSR_ANT 1_w_o Earphone_w_Holste

DUT: 120703C13

Communication System: WLAN_5G; Frequency: 5745 MHz; Duty Cycle: 1:1

Medium: B5G_0824 Medium parameters used: $f = 5745$ MHz; $\sigma = 6.019$ mho/m; $\epsilon_r = 48.128$; $\rho = 1000$ kg/m³

Ambient Temperature : 21.5 °C ; Liquid Temperature : 20.4 °C

DASY5 Configuration:

- Probe: EX3DV4 - SN3590; ConvF(4.54, 4.54, 4.54); Calibrated: 2012/02/23;
- Sensor-Surface: 2mm (Mechanical Surface Detection)
- Electronics: DAE3 Sn579; Calibrated: 2012/04/27
- Phantom: SAM with CRP v5.0 Front; Type: QD000P40CD; Serial: TP:1653
- Measurement SW: DASY52, Version 52.8 (2); SEMCAD X Version 14.6.6 (6824)

Ch149/Area Scan (161x221x1): Measurement grid: dx=10mm, dy=10mm

Maximum value of SAR (interpolated) = 0.0779 W/kg

Ch149/Zoom Scan (7x7x9)/Cube 0: Measurement grid: dx=4mm, dy=4mm, dz=2.5mm

Reference Value = 0.509 V/m; Power Drift = -0.01 dB

Peak SAR (extrapolated) = 0.210 mW/g

SAR(1 g) = 0.021 mW/g; SAR(10 g) = 0.00767 mW/g

Maximum value of SAR (measured) = 0.165 W/kg

Ch149/Zoom Scan (7x7x9)/Cube 1: Measurement grid: dx=4mm, dy=4mm, dz=2.5mm

Reference Value = 0.509 V/m; Power Drift = -0.01 dB

Peak SAR (extrapolated) = 1.029 mW/g

SAR(1 g) = 0.00598 mW/g; SAR(10 g) = 0.000562 mW/g

Maximum value of SAR (measured) = 1.03 W/kg

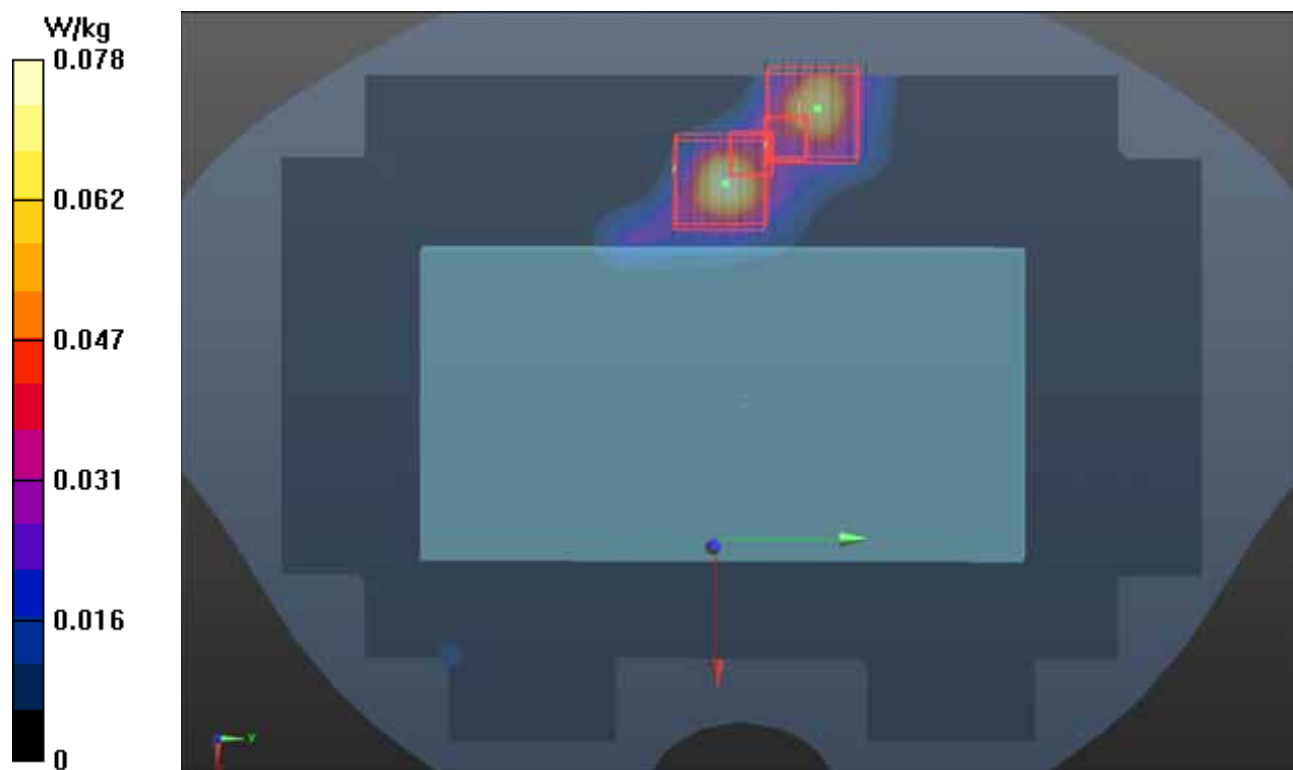

P128 802.11n_HT20_Rear Face_0cm_Ch149_w_MSR_ANT 1_w_o Earphone_w_Holste

DUT: 120703C13

Communication System: WLAN_5G; Frequency: 5745 MHz; Duty Cycle: 1:1

Medium: B5G_0824 Medium parameters used: $f = 5745$ MHz; $\sigma = 6.019$ mho/m; $\epsilon_r = 48.128$; $\rho = 1000$ kg/m³

Ambient Temperature : 21.5 °C ; Liquid Temperature : 20.4 °C

DASY5 Configuration:

- Probe: EX3DV4 - SN3590; ConvF(4.54, 4.54, 4.54); Calibrated: 2012/02/23;
- Sensor-Surface: 2mm (Mechanical Surface Detection)
- Electronics: DAE3 Sn579; Calibrated: 2012/04/27
- Phantom: SAM with CRP v5.0 Front; Type: QD000P40CD; Serial: TP:1653
- Measurement SW: DASY52, Version 52.8 (2); SEMCAD X Version 14.6.6 (6824)

Ch149/Area Scan (161x221x1): Measurement grid: dx=10mm, dy=10mm

Maximum value of SAR (interpolated) = 1.10 W/kg

Ch149/Zoom Scan (7x7x9)/Cube 0: Measurement grid: dx=4mm, dy=4mm, dz=2.5mm

Reference Value = 5.601 V/m; Power Drift = 0.03 dB

Peak SAR (extrapolated) = 4.748 mW/g

SAR(1 g) = 0.505 mW/g; SAR(10 g) = 0.214 mW/g

Maximum value of SAR (measured) = 1.01 W/kg

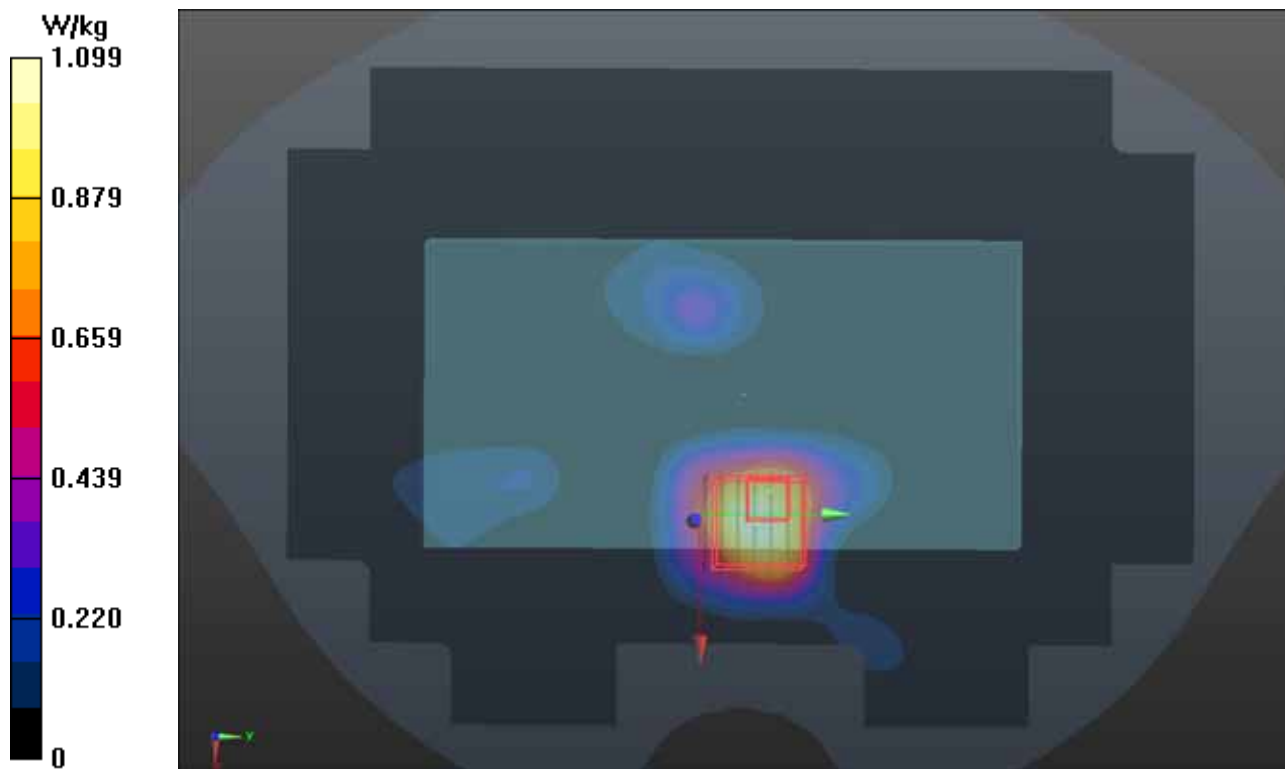



Appendix C. Calibration Certificate for Probe and Dipole

The SPEAG calibration certificates are shown as follows.



Accredited by the Swiss Accreditation Service (SAS)
The Swiss Accreditation Service is one of the signatories to the EA
Multilateral Agreement for the recognition of calibration certificates

Accreditation No.: **SCS 108**

Client **B.V.ADT (Auden)**

Certificate No: **D2450V2-737_Jan12**

CALIBRATION CERTIFICATE

Object **D2450V2 - SN: 737**

Calibration procedure(s) **QA CAL-05.v8
Calibration procedure for dipole validation kits above 700 MHz**

Calibration date: **January 24, 2012**

This calibration certificate documents the traceability to national standards, which realize the physical units of measurements (SI).
The measurements and the uncertainties with confidence probability are given on the following pages and are part of the certificate.

All calibrations have been conducted in the closed laboratory facility: environment temperature (22 ± 3)°C and humidity < 70%.

Calibration Equipment used (M&TE critical for calibration)

Primary Standards	ID #	Cal Date (Certificate No.)	Scheduled Calibration
Power meter EPM-442A	GB37480704	05-Oct-11 (No. 217-01451)	Oct-12
Power sensor HP 8481A	US37292783	05-Oct-11 (No. 217-01451)	Oct-12
Reference 20 dB Attenuator	SN: 5086 (20g)	29-Mar-11 (No. 217-01368)	Apr-12
Type-N mismatch combination	SN: 5047.2 / 06327	29-Mar-11 (No. 217-01371)	Apr-12
Reference Probe ES3DV3	SN: 3205	30-Dec-11 (No. ES3-3205_Dec11)	Dec-12
DAE4	SN: 601	04-Jul-11 (No. DAE4-601_Jul11)	Jul-12

Secondary Standards	ID #	Check Date (in house)	Scheduled Check
Power sensor HP 8481A	MY41092317	18-Oct-02 (in house check Oct-11)	In house check: Oct-13
RF generator R&S SMT-06	100005	04-Aug-99 (in house check Oct-11)	In house check: Oct-13
Network Analyzer HP 8753E	US37390585 S4206	18-Oct-01 (in house check Oct-11)	In house check: Oct-12

	Name	Function	Signature
Calibrated by:	Israe El-Naouq	Laboratory Technician	
Approved by:	Katja Pokovic	Technical Manager	

Issued: January 24, 2012

This calibration certificate shall not be reproduced except in full without written approval of the laboratory.



Accredited by the Swiss Accreditation Service (SAS)
The Swiss Accreditation Service is one of the signatories to the EA
Multilateral Agreement for the recognition of calibration certificates

Accreditation No.: **SCS 108**

Glossary:

TSL	tissue simulating liquid
ConvF	sensitivity in TSL / NORM x,y,z
N/A	not applicable or not measured

Calibration is Performed According to the Following Standards:

- a) IEEE Std 1528-2003, "IEEE Recommended Practice for Determining the Peak Spatial-Averaged Specific Absorption Rate (SAR) in the Human Head from Wireless Communications Devices: Measurement Techniques", December 2003
- b) IEC 62209-1, "Procedure to measure the Specific Absorption Rate (SAR) for hand-held devices used in close proximity to the ear (frequency range of 300 MHz to 3 GHz)", February 2005
- c) Federal Communications Commission Office of Engineering & Technology (FCC OET), "Evaluating Compliance with FCC Guidelines for Human Exposure to Radiofrequency Electromagnetic Fields; Additional Information for Evaluating Compliance of Mobile and Portable Devices with FCC Limits for Human Exposure to Radiofrequency Emissions", Supplement C (Edition 01-01) to Bulletin 65

Additional Documentation:

- d) DASY4/5 System Handbook

Methods Applied and Interpretation of Parameters:

- *Measurement Conditions:* Further details are available from the Validation Report at the end of the certificate. All figures stated in the certificate are valid at the frequency indicated.
- *Antenna Parameters with TSL:* The dipole is mounted with the spacer to position its feed point exactly below the center marking of the flat phantom section, with the arms oriented parallel to the body axis.
- *Feed Point Impedance and Return Loss:* These parameters are measured with the dipole positioned under the liquid filled phantom. The impedance stated is transformed from the measurement at the SMA connector to the feed point. The Return Loss ensures low reflected power. No uncertainty required.
- *Electrical Delay:* One-way delay between the SMA connector and the antenna feed point. No uncertainty required.
- *SAR measured:* SAR measured at the stated antenna input power.
- *SAR normalized:* SAR as measured, normalized to an input power of 1 W at the antenna connector.
- *SAR for nominal TSL parameters:* The measured TSL parameters are used to calculate the nominal SAR result.

Measurement Conditions

DASY system configuration, as far as not given on page 1.

DASY Version	DASY5	V52.8.0
Extrapolation	Advanced Extrapolation	
Phantom	Modular Flat Phantom	
Distance Dipole Center - TSL	10 mm	with Spacer
Zoom Scan Resolution	dx, dy, dz = 5 mm	
Frequency	2450 MHz \pm 1 MHz	

Head TSL parameters

The following parameters and calculations were applied.

	Temperature	Permittivity	Conductivity
Nominal Head TSL parameters	22.0 °C	39.2	1.80 mho/m
Measured Head TSL parameters	(22.0 \pm 0.2) °C	39.2 \pm 6 %	1.85 mho/m \pm 6 %
Head TSL temperature change during test	< 0.5 °C	----	----

SAR result with Head TSL

SAR averaged over 1 cm ³ (1 g) of Head TSL	Condition	
SAR measured	250 mW input power	13.4 mW / g
SAR for nominal Head TSL parameters	normalized to 1W	52.9 mW / g \pm 17.0 % (k=2)

SAR averaged over 10 cm ³ (10 g) of Head TSL	condition	
SAR measured	250 mW input power	6.18 mW / g
SAR for nominal Head TSL parameters	normalized to 1W	24.5 mW / g \pm 16.5 % (k=2)

Body TSL parameters

The following parameters and calculations were applied.

	Temperature	Permittivity	Conductivity
Nominal Body TSL parameters	22.0 °C	52.7	1.95 mho/m
Measured Body TSL parameters	(22.0 \pm 0.2) °C	50.6 \pm 6 %	2.01 mho/m \pm 6 %
Body TSL temperature change during test	< 0.5 °C	----	----

SAR result with Body TSL

SAR averaged over 1 cm ³ (1 g) of Body TSL	Condition	
SAR measured	250 mW input power	12.8 mW / g
SAR for nominal Body TSL parameters	normalized to 1W	50.0 mW / g \pm 17.0 % (k=2)

SAR averaged over 10 cm ³ (10 g) of Body TSL	condition	
SAR measured	250 mW input power	5.91 mW / g
SAR for nominal Body TSL parameters	normalized to 1W	23.3 mW / g \pm 16.5 % (k=2)

Appendix

Antenna Parameters with Head TSL

Impedance, transformed to feed point	54.3 Ω + 4.3 j Ω
Return Loss	- 24.7 dB

Antenna Parameters with Body TSL

Impedance, transformed to feed point	50.6 Ω + 5.3 j Ω
Return Loss	- 25.6 dB

General Antenna Parameters and Design

Electrical Delay (one direction)	1.161 ns
----------------------------------	----------

After long term use with 100W radiated power, only a slight warming of the dipole near the feedpoint can be measured.

The dipole is made of standard semirigid coaxial cable. The center conductor of the feeding line is directly connected to the second arm of the dipole. The antenna is therefore short-circuited for DC-signals. On some of the dipoles, small end caps are added to the dipole arms in order to improve matching when loaded according to the position as explained in the "Measurement Conditions" paragraph. The SAR data are not affected by this change. The overall dipole length is still according to the Standard.

No excessive force must be applied to the dipole arms, because they might bend or the soldered connections near the feedpoint may be damaged.

Additional EUT Data

Manufactured by	SPEAG
Manufactured on	August 26, 2003

DASY5 Validation Report for Head TSL

Date: 24.01.2012

Test Laboratory: SPEAG, Zurich, Switzerland

DUT: Dipole 2450 MHz; Type: D2450V2; Serial: D2450V2 - SN: 737

Communication System: CW; Frequency: 2450 MHz

Medium parameters used: $f = 2450$ MHz; $\sigma = 1.85$ mho/m; $\epsilon_r = 39.2$; $\rho = 1000$ kg/m³

Phantom section: Flat Section

Measurement Standard: DASY5 (IEEE/IEC/ANSI C63.19-2007)

DASY52 Configuration:

- Probe: ES3DV3 - SN3205; ConvF(4.45, 4.45, 4.45); Calibrated: 30.12.2011
- Sensor-Surface: 3mm (Mechanical Surface Detection)
- Electronics: DAE4 Sn601; Calibrated: 04.07.2011
- Phantom: Flat Phantom 5.0 (front); Type: QD000P50AA; Serial: 1001
- DASY52 52.8.0(692); SEMCAD X 14.6.4(4989)

Dipole Calibration for Head Tissue/Pin=250 mW, d=10mm/Zoom Scan (7x7x7)/Cube 0:

Measurement grid: dx=5mm, dy=5mm, dz=5mm

Reference Value = 99.933 V/m; Power Drift = 0.08 dB

Peak SAR (extrapolated) = 27.6400

SAR(1 g) = 13.4 mW/g; SAR(10 g) = 6.18 mW/g

Maximum value of SAR (measured) = 17.183 mW/g

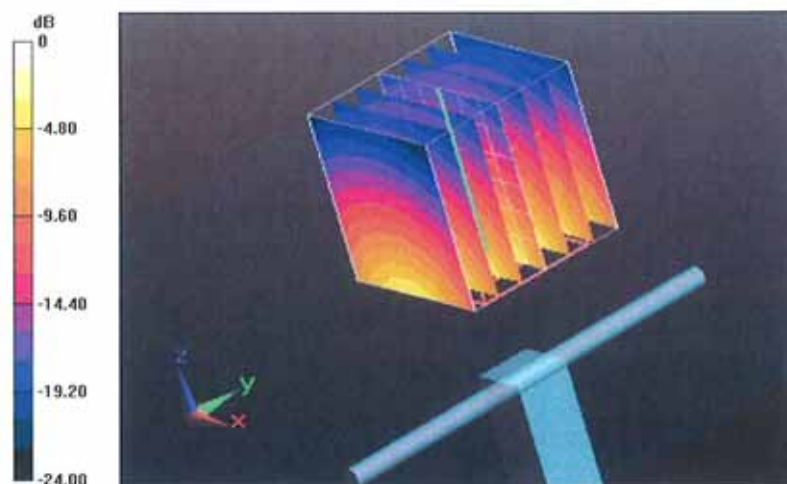

0 dB = 17.180mW/g = 24.70 dB mW/g

Impedance Measurement Plot for Head TSL

24 Jan 2012 11:02:13

CH1 S11 1 U FS

4: 54.291 \hat{r} 4.3184 \hat{r} 280.53 pF

2 450.000 000 MHz

*
De1

CA

avg
16

H1d

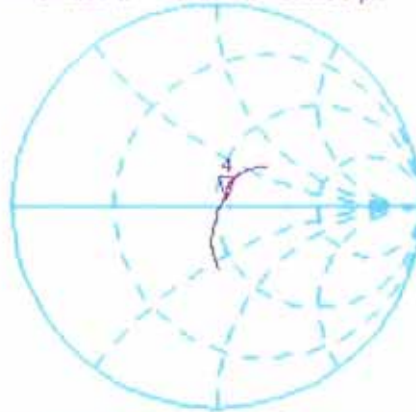

CH2 S11 LOG

5 dB/REF -20 dB

4:-24.678 dB

2 450.000 000 MHz

CA

avg
16

H1d

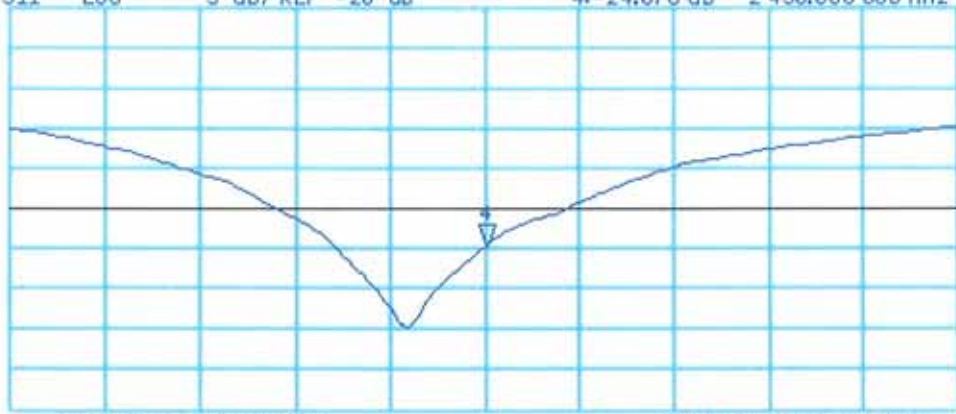

START 2 250.000 000 MHz

STOP 2 650.000 000 MHz

DASY5 Validation Report for Body TSL

Date: 23.01.2012

Test Laboratory: SPEAG, Zurich, Switzerland

DUT: Dipole 2450 MHz; Type: D2450V2; Serial: D2450V2 - SN: 737

Communication System: CW; Frequency: 2450 MHz

Medium parameters used: $f = 2450$ MHz; $\sigma = 2.01$ mho/m; $\epsilon_r = 50.6$; $\rho = 1000$ kg/m³

Phantom section: Flat Section

Measurement Standard: DASY5 (IEEE/IEC/ANSI C63.19-2007)

DASY52 Configuration:

- Probe: ES3DV3 - SN3205; ConvF(4.26, 4.26, 4.26); Calibrated: 30.12.2011
- Sensor-Surface: 3mm (Mechanical Surface Detection)
- Electronics: DAE4 Sn601; Calibrated: 04.07.2011
- Phantom: Flat Phantom 5.0 (back); Type: QD000P50AA; Serial: 1002
- DASY52 52.8.0(692); SEMCAD X 14.6.4(4989)

Dipole Calibration for Body Tissue/Pin=250 mW, d=10mm/Zoom Scan (7x7x7)/Cube 0:

Measurement grid: dx=5mm, dy=5mm, dz=5mm

Reference Value = 94.889 V/m; Power Drift = 0.03 dB

Peak SAR (extrapolated) = 26.6520

SAR(1 g) = 12.8 mW/g; SAR(10 g) = 5.91 mW/g

Maximum value of SAR (measured) = 17.026 mW/g

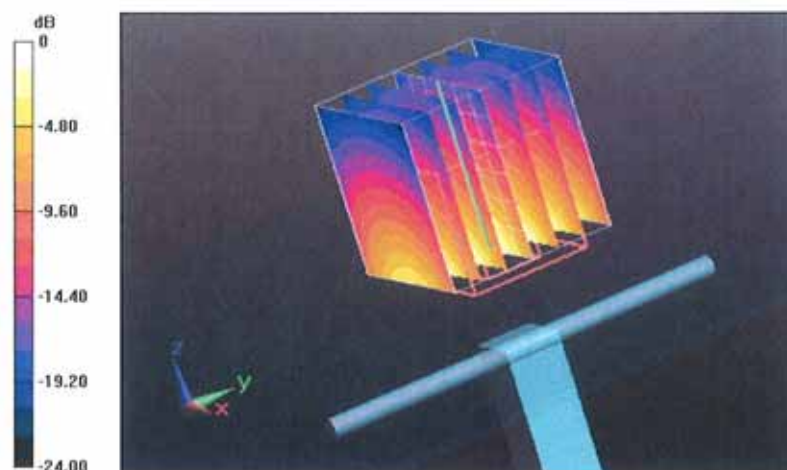

0 dB = 17.030mW/g = 24.62 dB mW/g

Impedance Measurement Plot for Body TSL

23 Jan 2012 11:06:18

CH1 S11 1 U FS

3: 50.611 Ω 5.2559 Ω 341.43 μH

2 450.000 000 MHz

*
De l
C Δ

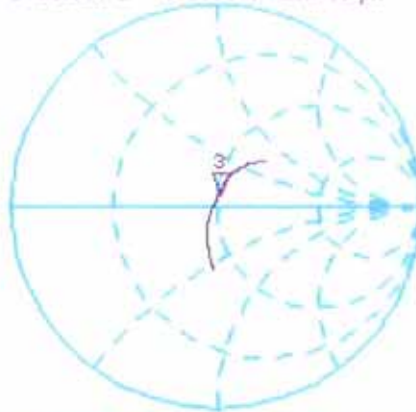

avg
16

H1 d

CH2 S11 LOG 5 dB/REF -20 dB 3:-25.587 dB 2 450.000 000 MHz

C Δ

avg
16

H1 d



START 2 250.000 000 MHz

STOP 2 650.000 000 MHz



Accredited by the Swiss Accreditation Service (SAS)
The Swiss Accreditation Service is one of the signatories to the EA
Multilateral Agreement for the recognition of calibration certificates

Accreditation No.: **SCS 108**

Client **B.V.ADT (Auden)**

Certificate No: **D5GHzV2-1018_Jan12**

CALIBRATION CERTIFICATE

Object **D5GHzV2 - SN: 1018**

Calibration procedure(s) **QA CAL-22.v1
Calibration procedure for dipole validation kits between 3-6 GHz**

Calibration date: **January 18, 2012**

This calibration certificate documents the traceability to national standards, which realize the physical units of measurements (SI).
The measurements and the uncertainties with confidence probability are given on the following pages and are part of the certificate.

All calibrations have been conducted in the closed laboratory facility: environment temperature (22 ± 3)°C and humidity < 70%.

Calibration Equipment used (M&TE critical for calibration)

Primary Standards	ID #	Cal Date (Certificate No.)	Scheduled Calibration
Power meter EPM-442A	GB37480704	05-Oct-11 (No. 217-01451)	Oct-12
Power sensor HP 8481A	US37292783	05-Oct-11 (No. 217-01451)	Oct-12
Reference 20 dB Attenuator	SN: 5086 (20g)	29-Mar-11 (No. 217-01368)	Apr-12
Type-N mismatch combination	SN: 5047.2 / 06327	29-Mar-11 (No. 217-01371)	Apr-12
Reference Probe EX3DV4	SN: 3503	30-Dec-11 (No. EX3-3503_Dec11)	Dec-12
DAE4	SN: 601	04-Jul-11 (No. DAE4-601_Jul11)	Jul-12
Secondary Standards	ID #	Check Date (in house)	Scheduled Check
Power sensor HP 8481A	MY41092317	18-Oct-02 (in house check Oct-11)	In house check: Oct-13
RF generator R&S SMT-06	100005	04-Aug-99 (in house check Oct-11)	In house check: Oct-13
Network Analyzer HP 8753E	US37390585 S4206	18-Oct-01 (in house check Oct-11)	In house check: Oct-12

	Name	Function	Signature
Calibrated by:	Jeton Kastrati	Laboratory Technician	
Approved by:	Katja Pokovic	Technical Manager	

Issued: January 18, 2012

This calibration certificate shall not be reproduced except in full without written approval of the laboratory.



Accredited by the Swiss Accreditation Service (SAS)
The Swiss Accreditation Service is one of the signatories to the EA
Multilateral Agreement for the recognition of calibration certificates

Accreditation No.: **SCS 108**

Glossary:

TSL	tissue simulating liquid
ConvF	sensitivity in TSL / NORM x,y,z
N/A	not applicable or not measured

Calibration is Performed According to the Following Standards:

- IEEE Std 1528-2003, "IEEE Recommended Practice for Determining the Peak Spatial-Averaged Specific Absorption Rate (SAR) in the Human Head from Wireless Communications Devices: Measurement Techniques", December 2003
- IEC 62209-1, "Procedure to measure the Specific Absorption Rate (SAR) for hand-held devices used in close proximity to the ear (frequency range of 300 MHz to 3 GHz)", February 2005
- Federal Communications Commission Office of Engineering & Technology (FCC OET), "Evaluating Compliance with FCC Guidelines for Human Exposure to Radiofrequency Electromagnetic Fields; Additional Information for Evaluating Compliance of Mobile and Portable Devices with FCC Limits for Human Exposure to Radiofrequency Emissions", Supplement C (Edition 01-01) to Bulletin 65

Additional Documentation:

- DASY4/5 System Handbook

Methods Applied and Interpretation of Parameters:

- Measurement Conditions:** Further details are available from the Validation Report at the end of the certificate. All figures stated in the certificate are valid at the frequency indicated.
- Antenna Parameters with TSL:** The dipole is mounted with the spacer to position its feed point exactly below the center marking of the flat phantom section, with the arms oriented parallel to the body axis.
- Feed Point Impedance and Return Loss:** These parameters are measured with the dipole positioned under the liquid filled phantom. The impedance stated is transformed from the measurement at the SMA connector to the feed point. The Return Loss ensures low reflected power. No uncertainty required.
- Electrical Delay:** One-way delay between the SMA connector and the antenna feed point. No uncertainty required.
- SAR measured:** SAR measured at the stated antenna input power.
- SAR normalized:** SAR as measured, normalized to an input power of 1 W at the antenna connector.
- SAR for nominal TSL parameters:** The measured TSL parameters are used to calculate the nominal SAR result.

Measurement Conditions

DASY system configuration, as far as not given on page 1.

DASY Version	DASY5	V52.8.0
Extrapolation	Advanced Extrapolation	
Phantom	Modular Flat Phantom V5.0	
Distance Dipole Center - TSL	10 mm	with Spacer
Zoom Scan Resolution	dx, dy = 4.0 mm, dz = 1.4 mm	Graded Ratio = 1.4 (Z direction)
Frequency	5200 MHz \pm 1 MHz 5500 MHz \pm 1 MHz 5800 MHz \pm 1 MHz	

Head TSL parameters at 5200 MHz

The following parameters and calculations were applied.

	Temperature	Permittivity	Conductivity
Nominal Head TSL parameters	22.0 °C	36.0	4.66 mho/m
Measured Head TSL parameters	(22.0 \pm 0.2) °C	36.3 \pm 6 %	4.60 mho/m \pm 6 %
Head TSL temperature change during test	< 0.5 °C	----	----

SAR result with Head TSL at 5200 MHz

SAR averaged over 1 cm ³ (1 g) of Head TSL	Condition	
SAR measured	100 mW input power	7.95 mW / g
SAR for nominal Head TSL parameters	normalized to 1W	79.6 mW / g \pm 17.0 % (k=2)

SAR averaged over 10 cm ³ (10 g) of Head TSL	condition	
SAR measured	100 mW input power	2.27 mW / g
SAR for nominal Head TSL parameters	normalized to 1W	22.7 mW / g \pm 16.5 % (k=2)

Head TSL parameters at 5500 MHz

The following parameters and calculations were applied.

	Temperature	Permittivity	Conductivity
Nominal Head TSL parameters	22.0 °C	35.6	4.96 mho/m
Measured Head TSL parameters	(22.0 \pm 0.2) °C	35.8 \pm 6 %	4.90 mho/m \pm 6 %
Head TSL temperature change during test	< 0.5 °C	----	----

SAR result with Head TSL at 5500 MHz

SAR averaged over 1 cm ³ (1 g) of Head TSL	Condition	
SAR measured	100 mW input power	8.47 mW / g
SAR for nominal Head TSL parameters	normalized to 1W	84.7 mW / g \pm 17.0 % (k=2)

SAR averaged over 10 cm ³ (10 g) of Head TSL	condition	
SAR measured	100 mW input power	2.41 mW / g
SAR for nominal Head TSL parameters	normalized to 1W	24.1 mW / g \pm 16.5 % (k=2)

Head TSL parameters at 5800 MHz

The following parameters and calculations were applied.

	Temperature	Permittivity	Conductivity
Nominal Head TSL parameters	22.0 °C	35.3	5.27 mho/m
Measured Head TSL parameters	(22.0 ± 0.2) °C	35.3 ± 6 %	5.22 mho/m ± 6 %
Head TSL temperature change during test	< 0.5 °C	----	----

SAR result with Head TSL at 5800 MHz

SAR averaged over 1 cm ³ (1 g) of Head TSL	Condition	
SAR measured	100 mW input power	7.86 mW / g
SAR for nominal Head TSL parameters	normalized to 1W	78.6 mW / g ± 17.0 % (k=2)

SAR averaged over 10 cm ³ (10 g) of Head TSL	condition	
SAR measured	100 mW input power	2.23 mW / g
SAR for nominal Head TSL parameters	normalized to 1W	22.3 mW / g ± 16.5 % (k=2)

Body TSL parameters at 5200 MHz

The following parameters and calculations were applied.

	Temperature	Permittivity	Conductivity
Nominal Body TSL parameters	22.0 °C	49.0	5.30 mho/m
Measured Body TSL parameters	(22.0 ± 0.2) °C	49.2 ± 6 %	5.46 mho/m ± 6 %
Body TSL temperature change during test	< 0.5 °C	----	----

SAR result with Body TSL at 5200 MHz

SAR averaged over 1 cm ³ (1 g) of Body TSL	Condition	
SAR measured	100 mW input power	7.26 mW / g
SAR for nominal Body TSL parameters	normalized to 1W	72.7 mW / g ± 18.1 % (k=2)

SAR averaged over 10 cm ³ (10 g) of Body TSL	condition	
SAR measured	100 mW input power	2.04 mW / g
SAR for nominal Body TSL parameters	normalized to 1W	20.5 mW / g ± 17.6 % (k=2)

Body TSL parameters at 5500 MHz

The following parameters and calculations were applied.

	Temperature	Permittivity	Conductivity
Nominal Body TSL parameters	22.0 °C	48.6	5.65 mho/m
Measured Body TSL parameters	(22.0 ± 0.2) °C	48.7 ± 6 %	5.86 mho/m ± 6 %
Body TSL temperature change during test	< 0.5 °C	----	----

SAR result with Body TSL at 5500 MHz

SAR averaged over 1 cm ³ (1 g) of Body TSL	Condition	
SAR measured	100 mW input power	7.82 mW / g
SAR for nominal Body TSL parameters	normalized to 1W	78.3 mW / g ± 18.1 % (k=2)

SAR averaged over 10 cm ³ (10 g) of Body TSL	condition	
SAR measured	100 mW input power	2.18 mW / g
SAR for nominal Body TSL parameters	normalized to 1W	21.8 mW / g ± 17.6 % (k=2)

Body TSL parameters at 5800 MHz

The following parameters and calculations were applied.

	Temperature	Permittivity	Conductivity
Nominal Body TSL parameters	22.0 °C	48.2	6.00 mho/m
Measured Body TSL parameters	(22.0 ± 0.2) °C	48.2 ± 6 %	6.28 mho/m ± 6 %
Body TSL temperature change during test	< 0.5 °C	----	----

SAR result with Body TSL at 5800 MHz

SAR averaged over 1 cm ³ (1 g) of Body TSL	Condition	
SAR measured	100 mW input power	7.33 mW / g
SAR for nominal Body TSL parameters	normalized to 1W	73.4 mW / g ± 18.1 % (k=2)

SAR averaged over 10 cm ³ (10 g) of Body TSL	condition	
SAR measured	100 mW input power	2.03 mW / g
SAR for nominal Body TSL parameters	normalized to 1W	20.3 mW / g ± 17.6 % (k=2)

Appendix

Antenna Parameters with Head TSL at 5200 MHz

Impedance, transformed to feed point	53.1 Ω - 9.5 j Ω
Return Loss	- 20.3 dB

Antenna Parameters with Head TSL at 5500 MHz

Impedance, transformed to feed point	50.7 Ω - 3.8 j Ω
Return Loss	- 28.4 dB

Antenna Parameters with Head TSL at 5800 MHz

Impedance, transformed to feed point	56.4 Ω + 1.4 j Ω
Return Loss	- 24.3 dB

Antenna Parameters with Body TSL at 5200 MHz

Impedance, transformed to feed point	52.3 Ω - 8.4 j Ω
Return Loss	- 21.4 dB

Antenna Parameters with Body TSL at 5500 MHz

Impedance, transformed to feed point	49.2 Ω + 0.0 j Ω
Return Loss	- 42.3 dB

Antenna Parameters with Body TSL at 5800 MHz

Impedance, transformed to feed point	54.4 Ω - 6.9 j Ω
Return Loss	- 22.1 dB

General Antenna Parameters and Design

Electrical Delay (one direction)	1.106 ns
----------------------------------	----------

After long term use with 100W radiated power, only a slight warming of the dipole near the feedpoint can be measured.

The dipole is made of standard semirigid coaxial cable. The center conductor of the feeding line is directly connected to the second arm of the dipole. The antenna is therefore short-circuited for DC-signals. On some of the dipoles, small end caps are added to the dipole arms in order to improve matching when loaded according to the position as explained in the "Measurement Conditions" paragraph. The SAR data are not affected by this change. The overall dipole length is still according to the Standard.

No excessive force must be applied to the dipole arms, because they might bend or the soldered connections near the feedpoint may be damaged.

Additional EUT Data

Manufactured by	SPEAG
Manufactured on	February 05, 2004

DASY5 Validation Report for Head TSL

Date: 17.01.2012

Test Laboratory: SPEAG, Zurich, Switzerland

DUT: Dipole 5GHz; Type: D5GHzV2; Serial: D5GHzV2 - SN: 1018

Communication System: CW; Frequency: 5200 MHz, Frequency: 5500 MHz, Frequency: 5800 MHz
Medium parameters used: $f = 5200$ MHz; $\sigma = 4.6$ mho/m; $\epsilon_r = 36.3$; $\rho = 1000$ kg/m³, Medium parameters used: $f = 5500$ MHz; $\sigma = 4.9$ mho/m; $\epsilon_r = 35.8$; $\rho = 1000$ kg/m³, Medium parameters used: $f = 5800$ MHz; $\sigma = 5.22$ mho/m; $\epsilon_r = 35.3$; $\rho = 1000$ kg/m³
Phantom section: Flat Section
Measurement Standard: DASY5 (IEEE/IEC/ANSI C63.19-2007)

DASY52 Configuration:

- Probe: EX3DV4 - SN3503; ConvF(5.41, 5.41, 5.41), ConvF(4.91, 4.91, 4.91), ConvF(4.81, 4.81, 4.81); Calibrated: 30.12.2011
- Sensor-Surface: 1.4mm (Mechanical Surface Detection)
- Electronics: DAE4 Sn601; Calibrated: 04.07.2011
- Phantom: Flat Phantom 5.0 (front); Type: QD000P50AA; Serial: 1001
- DASY52 52.8.0(692); SEMCAD X 14.6.4(4989)

Dipole Calibration for Head Tissue/Pin=100mW, dist=10mm, f=5200 MHz/Zoom Scan, dist=1.4mm (8x8x7)/Cube 0: Measurement grid: dx=4mm, dy=4mm, dz=1.4mm

Reference Value = 63.604 V/m; Power Drift = 0.09 dB

Peak SAR (extrapolated) = 29.6500

SAR(1 g) = 7.95 mW/g; SAR(10 g) = 2.27 mW/g

Maximum value of SAR (measured) = 18.292 mW/g

Dipole Calibration for Head Tissue/Pin=100mW, dist=10mm, f=5500 MHz/Zoom Scan, dist=1.4mm (8x8x7)/Cube 0: Measurement grid: dx=4mm, dy=4mm, dz=1.4mm

Reference Value = 63.798 V/m; Power Drift = 0.02 dB

Peak SAR (extrapolated) = 33.9410

SAR(1 g) = 8.47 mW/g; SAR(10 g) = 2.41 mW/g

Maximum value of SAR (measured) = 20.236 mW/g

Dipole Calibration for Head Tissue/Pin=100mW, dist=10mm, f=5800 MHz/Zoom Scan, dist=1.4mm (8x8x7)/Cube 0: Measurement grid: dx=4mm, dy=4mm, dz=1.4mm

Reference Value = 60.556 V/m; Power Drift = 0.07 dB

Peak SAR (extrapolated) = 33.2500

SAR(1 g) = 7.86 mW/g; SAR(10 g) = 2.23 mW/g

Maximum value of SAR (measured) = 19.231 mW/g

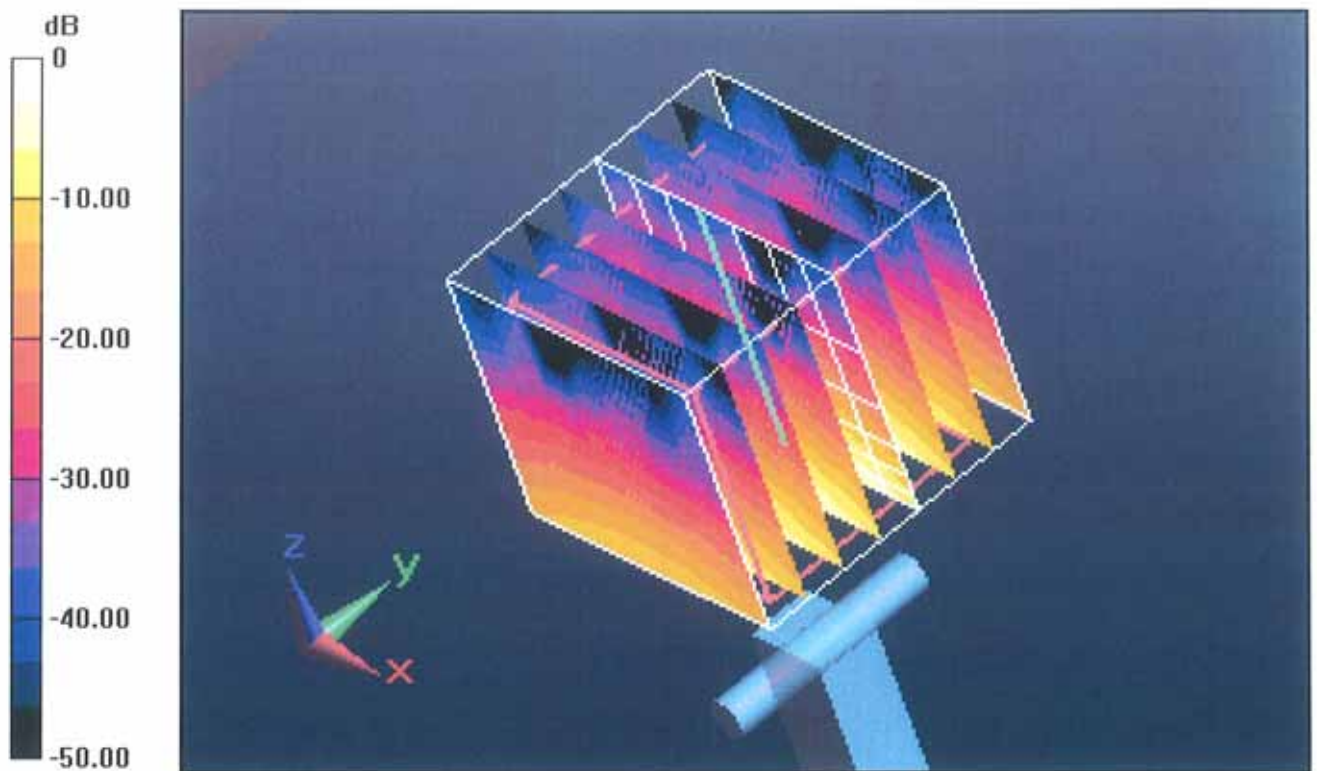

0 dB = 19.230mW/g = 25.68 dB mW/g

Impedance Measurement Plot for Head TSL

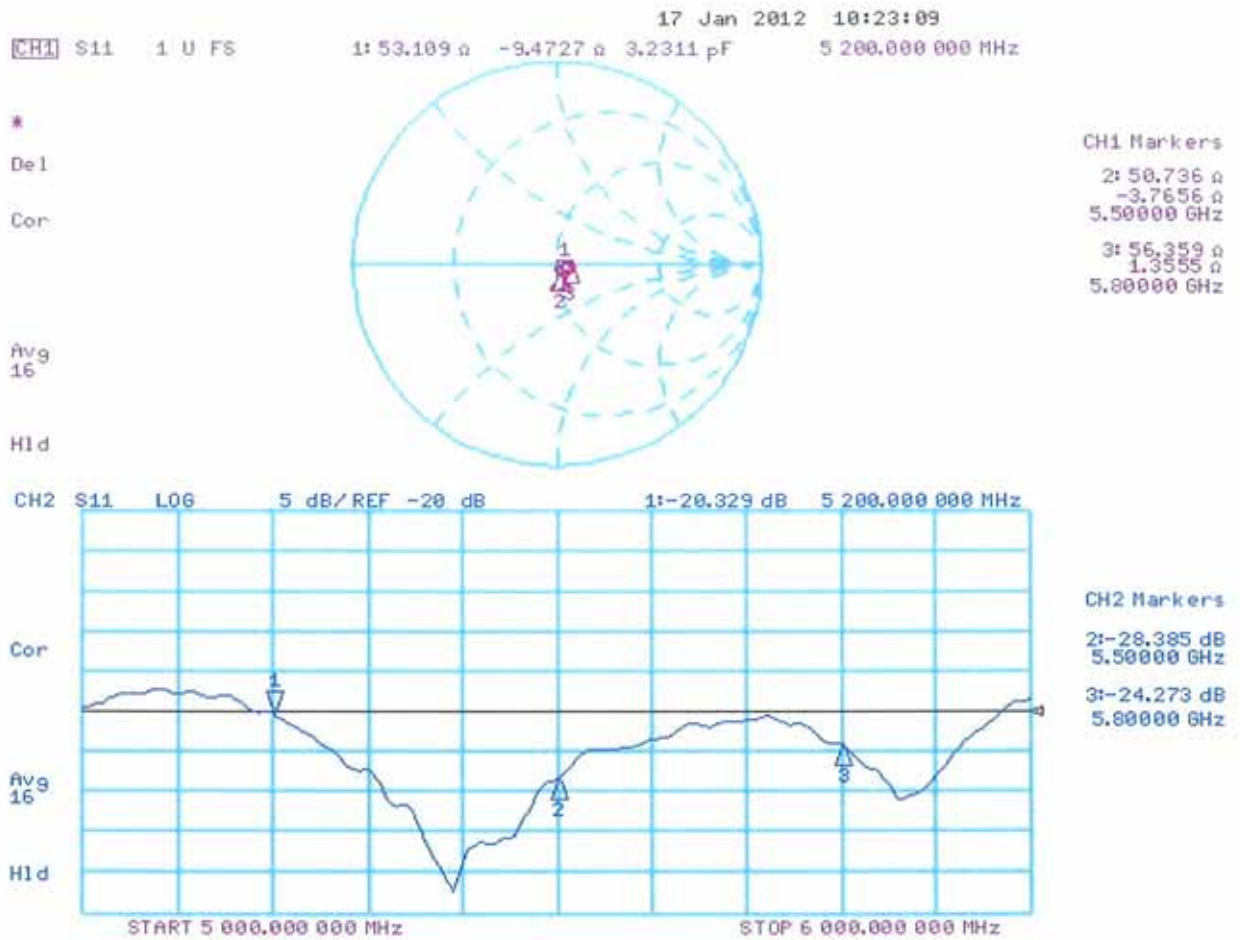

DASY5 Validation Report for Body TSL

Date: 18.01.2012

Test Laboratory: SPEAG, Zurich, Switzerland

DUT: Dipole 5GHz; Type: D5GHzV2; Serial: D5GHzV2 - SN: 1018

Communication System: CW; Frequency: 5200 MHz, Frequency: 5500 MHz, Frequency: 5800 MHz
Medium parameters used: $f = 5200$ MHz; $\sigma = 5.46$ mho/m; $\epsilon_r = 49.2$; $\rho = 1000$ kg/m³, Medium parameters used: $f = 5500$ MHz; $\sigma = 5.86$ mho/m; $\epsilon_r = 48.7$; $\rho = 1000$ kg/m³, Medium parameters used: $f = 5800$ MHz; $\sigma = 6.28$ mho/m; $\epsilon_r = 48.2$; $\rho = 1000$ kg/m³
Phantom section: Flat Section
Measurement Standard: DASY5 (IEEE/IEC/ANSI C63.19-2007)

DASY52 Configuration:

- Probe: EX3DV4 - SN3503; ConvF(4.91, 4.91, 4.91), ConvF(4.43, 4.43, 4.43), ConvF(4.38, 4.38, 4.38); Calibrated: 30.12.2011
- Sensor-Surface: 1.4mm (Mechanical Surface Detection)
- Electronics: DAE4 Sn601; Calibrated: 04.07.2011
- Phantom: Flat Phantom 5.0 (back); Type: QD000P50AA; Serial: 1002
- DASY52 52.8.0(692); SEMCAD X 14.6.4(4989)

Dipole Calibration for Body Tissue/Pin=100mW, dist=10mm, f=5200 MHz/Zoom Scan, dist=1.4mm (8x8x7)/Cube 0: Measurement grid: dx=4mm, dy=4mm, dz=1.4mm

Reference Value = 57.349 V/m; Power Drift = -0.06 dB

Peak SAR (extrapolated) = 28.4300

SAR(1 g) = 7.26 mW/g; SAR(10 g) = 2.04 mW/g

Maximum value of SAR (measured) = 17.187 mW/g

Dipole Calibration for Body Tissue/Pin=100mW, dist=10mm, f=5500 MHz/Zoom Scan, dist=1.4mm (8x8x7)/Cube 0: Measurement grid: dx=4mm, dy=4mm, dz=1.4mm

Reference Value = 57.629 V/m; Power Drift = -0.04 dB

Peak SAR (extrapolated) = 33.3620

SAR(1 g) = 7.82 mW/g; SAR(10 g) = 2.18 mW/g

Maximum value of SAR (measured) = 19.092 mW/g

Dipole Calibration for Body Tissue/Pin=100mW, dist=10mm, f=5800 MHz/Zoom Scan, dist=1.4mm (8x8x7)/Cube 0: Measurement grid: dx=4mm, dy=4mm, dz=1.4mm

Reference Value = 54.181 V/m; Power Drift = -0.04 dB

Peak SAR (extrapolated) = 34.3080

SAR(1 g) = 7.33 mW/g; SAR(10 g) = 2.03 mW/g

Maximum value of SAR (measured) = 18.527 mW/g

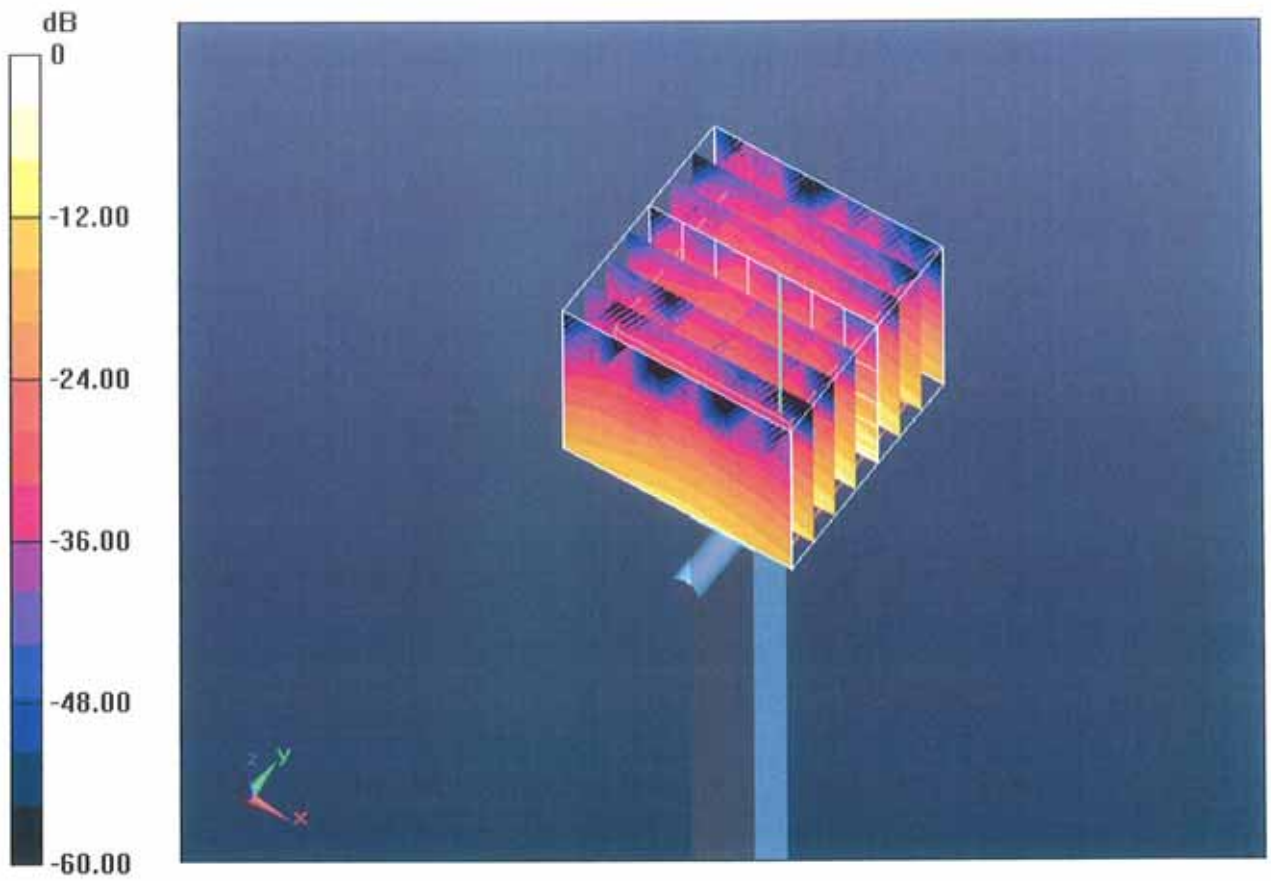

0 dB = 18.530mW/g = 25.36 dB mW/g

Impedance Measurement Plot for Body TSL

18 Jan 2012 10:59:45

CH1 S11 1 U FS 1: 52.322 Ω -8.3770 Ω 3.6537 μ F 5 200.000 000 MHz

*
Del
Cor

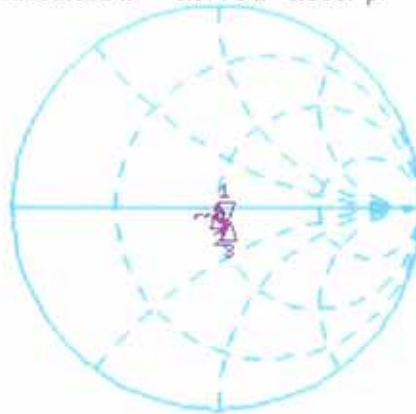

CH1 Markers
2: 49.238 Ω
0.0313 Ω
5.50000 GHz
3: 54.357 Ω
-6.9395 Ω
5.80000 GHz

Avg
16

H1d

CH2 S11 LOG 5 dB/REF -20 dB 1: -21.442 dB 5 200.000 000 MHz

Cor



CH2 Markers
2: -42.283 dB
5.50000 GHz
3: -22.122 dB
5.80000 GHz

Avg
16

H1d

**Calibration Laboratory of
Schmid & Partner
Engineering AG**
Zeughausstrasse 43, 8004 Zurich, Switzerland



S Schweizerischer Kalibrierdienst
C Service suisse d'étalonnage
S Servizio svizzero di taratura
S Swiss Calibration Service

Accredited by the Swiss Accreditation Service (SAS)
The Swiss Accreditation Service is one of the signatories to the EA
Multilateral Agreement for the recognition of calibration certificates

Accreditation No.: **SCS 108**

Client **B.V. ADT (Auden)**

Certificate No: **EX3-3650_Oct11**

CALIBRATION CERTIFICATE

Object: **EX3DV4 - SN:3650**

Calibration procedure(s): **QA CAL-01.v8, QA CAL-14.v3, QA CAL-23.v4, QA CAL-25.v4
Calibration procedure for dosimetric E-field probes**

Calibration date: **October 26, 2011**

This calibration certificate documents the traceability to national standards, which realize the physical units of measurements (SI).
The measurements and the uncertainties with confidence probability are given on the following pages and are part of the certificate.

All calibrations have been conducted in the closed laboratory facility: environment temperature (22 ± 3)°C and humidity < 70%.

Calibration Equipment used (M&TE critical for calibration)

Primary Standards	ID	Cal Date (Certificate No.)	Scheduled Calibration
Power meter E4419B	GB41293874	31-Mar-11 (No. 217-01372)	Apr-12
Power sensor E4412A	MY41498087	31-Mar-11 (No. 217-01372)	Apr-12
Reference 3 dB Attenuator	SN: S5054 (3c)	29-Mar-11 (No. 217-01369)	Apr-12
Reference 20 dB Attenuator	SN: S5086 (20b)	29-Mar-11 (No. 217-01367)	Apr-12
Reference 30 dB Attenuator	SN: S5129 (30b)	29-Mar-11 (No. 217-01370)	Apr-12
Reference Probe ES3DV2	SN: 3013	29-Dec-10 (No. ES3-3013_Dec10)	Dec-11
DAE4	SN: 654	3-May-11 (No. DAE4-654_May11)	May-12
Secondary Standards	ID	Check Date (in house)	Scheduled Check
RF generator HP 8648C	US3642U01700	4-Aug-99 (in house check Apr-11)	In house check: Apr-13
Network Analyzer HP 8753E	US37390585	18-Oct-01 (in house check Oct-11)	In house check: Oct-12

	Name	Function	Signature
Calibrated by:	Jeton Kastrati	Laboratory Technician	
Approved by:	Katja Pokovic	Technical Manager	

Issued: October 27, 2011

This calibration certificate shall not be reproduced except in full without written approval of the laboratory.



Accredited by the Swiss Accreditation Service (SAS)
The Swiss Accreditation Service is one of the signatories to the EA
Multilateral Agreement for the recognition of calibration certificates

Accreditation No.: **SCS 108**

Glossary:

TSL	tissue simulating liquid
NORM _{x,y,z}	sensitivity in free space
ConvF	sensitivity in TSL / NORM _{x,y,z}
DCP	diode compression point
CF	crest factor (1/duty_cycle) of the RF signal
A, B, C	modulation dependent linearization parameters
Polarization φ	φ rotation around probe axis
Polarization ϑ	ϑ rotation around an axis that is in the plane normal to probe axis (at measurement center), i.e., $\vartheta = 0$ is normal to probe axis

Calibration is Performed According to the Following Standards:

- IEEE Std 1528-2003, "IEEE Recommended Practice for Determining the Peak Spatial-Averaged Specific Absorption Rate (SAR) in the Human Head from Wireless Communications Devices: Measurement Techniques", December 2003
- IEC 62209-1, "Procedure to measure the Specific Absorption Rate (SAR) for hand-held devices used in close proximity to the ear (frequency range of 300 MHz to 3 GHz)", February 2005

Methods Applied and Interpretation of Parameters:

- NORM_{x,y,z}**: Assessed for E-field polarization $\vartheta = 0$ ($f \leq 900$ MHz in TEM-cell; $f > 1800$ MHz: R22 waveguide). NORM_{x,y,z} are only intermediate values, i.e., the uncertainties of NORM_{x,y,z} does not affect the E²-field uncertainty inside TSL (see below ConvF).
- NORM(f)_{x,y,z} = NORM_{x,y,z} * frequency_response** (see Frequency Response Chart). This linearization is implemented in DASY4 software versions later than 4.2. The uncertainty of the frequency response is included in the stated uncertainty of ConvF.
- DCP_{x,y,z}**: DCP are numerical linearization parameters assessed based on the data of power sweep with CW signal (no uncertainty required). DCP does not depend on frequency nor media.
- PAR**: PAR is the Peak to Average Ratio that is not calibrated but determined based on the signal characteristics
- A_{x,y,z}; B_{x,y,z}; C_{x,y,z}; VR_{x,y,z}**: A, B, C are numerical linearization parameters assessed based on the data of power sweep for specific modulation signal. The parameters do not depend on frequency nor media. VR is the maximum calibration range expressed in RMS voltage across the diode.
- ConvF and Boundary Effect Parameters**: Assessed in flat phantom using E-field (or Temperature Transfer Standard for $f \leq 800$ MHz) and inside waveguide using analytical field distributions based on power measurements for $f > 800$ MHz. The same setups are used for assessment of the parameters applied for boundary compensation (alpha, depth) of which typical uncertainty values are given. These parameters are used in DASY4 software to improve probe accuracy close to the boundary. The sensitivity in TSL corresponds to NORM_{x,y,z} * ConvF whereby the uncertainty corresponds to that given for ConvF. A frequency dependent ConvF is used in DASY version 4.4 and higher which allows extending the validity from ± 50 MHz to ± 100 MHz.
- Spherical isotropy (3D deviation from isotropy)**: in a field of low gradients realized using a flat phantom exposed by a patch antenna.
- Sensor Offset**: The sensor offset corresponds to the offset of virtual measurement center from the probe tip (on probe axis). No tolerance required.

Probe EX3DV4

SN:3650

Manufactured: March 18, 2008
Calibrated: October 26, 2011

Calibrated for DASYS/EASY Systems
(Note: non-compatible with DASYS2 system!)

DASY/EASY - Parameters of Probe: EX3DV4 - SN:3650

Basic Calibration Parameters

	Sensor X	Sensor Y	Sensor Z	Unc (k=2)
Norm ($\mu\text{V}/(\text{V}/\text{m})^2$) ^A	0.36	0.37	0.46	$\pm 10.1 \%$
DCP (mV) ^B	98.5	94.0	98.2	

Modulation Calibration Parameters

UID	Communication System Name	PAR		A dB	B dB	C dB	VR mV	Unc ^E (k=2)
10000	CW	0.00	X	0.00	0.00	1.00	94.9	$\pm 2.5 \%$
			Y	0.00	0.00	1.00	90.7	
			Z	0.00	0.00	1.00	114.0	

The reported uncertainty of measurement is stated as the standard uncertainty of measurement multiplied by the coverage factor $k=2$, which for a normal distribution corresponds to a coverage probability of approximately 95%.

^A The uncertainties of NormX,Y,Z do not affect the E^2 -field uncertainty inside TSL (see Pages 5 and 6).

^B Numerical linearization parameter: uncertainty not required.

^E Uncertainty is determined using the max. deviation from linear response applying rectangular distribution and is expressed for the square of the field value.

DASY/EASY - Parameters of Probe: EX3DV4 - SN:3650

Calibration Parameter Determined in Head Tissue Simulating Media

f (MHz) ^C	Relative Permittivity ^F	Conductivity (S/m) ^F	ConvF X	ConvF Y	ConvF Z	Alpha	Depth (mm)	Unct. (k=2)
750	41.9	0.89	9.20	9.20	9.20	0.79	0.69	± 12.0 %
835	41.5	0.90	8.87	8.87	8.87	0.79	0.69	± 12.0 %
1450	40.5	1.20	8.32	8.32	8.32	0.79	0.65	± 12.0 %
1750	40.1	1.37	7.92	7.92	7.92	0.70	0.63	± 12.0 %
1950	40.0	1.40	7.40	7.40	7.40	0.79	0.54	± 12.0 %
2450	39.2	1.80	6.80	6.80	6.80	0.59	0.62	± 12.0 %
2600	39.0	1.96	6.68	6.68	6.68	0.50	0.74	± 12.0 %
5200	36.0	4.66	5.05	5.05	5.05	0.35	1.80	± 13.1 %
5300	35.9	4.76	4.71	4.71	4.71	0.40	1.80	± 13.1 %
5500	35.6	4.96	4.56	4.56	4.56	0.45	1.80	± 13.1 %
5600	35.5	5.07	4.42	4.42	4.42	0.45	1.80	± 13.1 %
5800	35.3	5.27	4.30	4.30	4.30	0.50	1.80	± 13.1 %

^C Frequency validity of ± 100 MHz only applies for DASY v4.4 and higher (see Page 2), else it is restricted to ± 50 MHz. The uncertainty is the RSS of the ConvF uncertainty at calibration frequency and the uncertainty for the indicated frequency band.

^F At frequencies below 3 GHz, the validity of tissue parameters (ϵ and σ) can be relaxed to ± 10% if liquid compensation formula is applied to measured SAR values. At frequencies above 3 GHz, the validity of tissue parameters (ϵ and σ) is restricted to ± 5%. The uncertainty is the RSS of the ConvF uncertainty for indicated target tissue parameters.

DASY/EASY - Parameters of Probe: EX3DV4 - SN:3650

Calibration Parameter Determined in Body Tissue Simulating Media

f (MHz) ^C	Relative Permittivity ^F	Conductivity (S/m) ^F	ConvF X	ConvF Y	ConvF Z	Alpha	Depth (mm)	Unct. (k=2)
750	55.5	0.96	9.21	9.21	9.21	0.78	0.69	± 12.0 %
835	55.2	0.97	9.12	9.12	9.12	0.79	0.67	± 12.0 %
1450	54.0	1.30	8.09	8.09	8.09	0.79	0.63	± 12.0 %
1750	53.4	1.49	7.49	7.49	7.49	0.79	0.64	± 12.0 %
1950	53.3	1.52	7.46	7.46	7.46	0.79	0.65	± 12.0 %
2450	52.7	1.95	6.89	6.89	6.89	0.79	0.60	± 12.0 %
2600	52.5	2.16	6.79	6.79	6.79	0.72	0.58	± 12.0 %
5200	49.0	5.30	4.28	4.28	4.28	0.50	1.95	± 13.1 %
5300	48.9	5.42	4.11	4.11	4.11	0.50	1.95	± 13.1 %
5500	48.6	5.65	3.73	3.73	3.73	0.60	1.95	± 13.1 %
5600	48.5	5.77	3.57	3.57	3.57	0.60	1.95	± 13.1 %
5800	48.2	6.00	3.81	3.81	3.81	0.60	1.95	± 13.1 %

^C Frequency validity of ± 100 MHz only applies for DASY v4.4 and higher (see Page 2), else it is restricted to ± 50 MHz. The uncertainty is the RSS of the ConvF uncertainty at calibration frequency and the uncertainty for the indicated frequency band.

^F At frequencies below 3 GHz, the validity of tissue parameters (ϵ and σ) can be relaxed to ± 10% if liquid compensation formula is applied to measured SAR values. At frequencies above 3 GHz, the validity of tissue parameters (ϵ and σ) is restricted to ± 5%. The uncertainty is the RSS of the ConvF uncertainty for indicated target tissue parameters.

Frequency Response of E-Field (TEM-Cell:ifi110 EXX, Waveguide: R22)

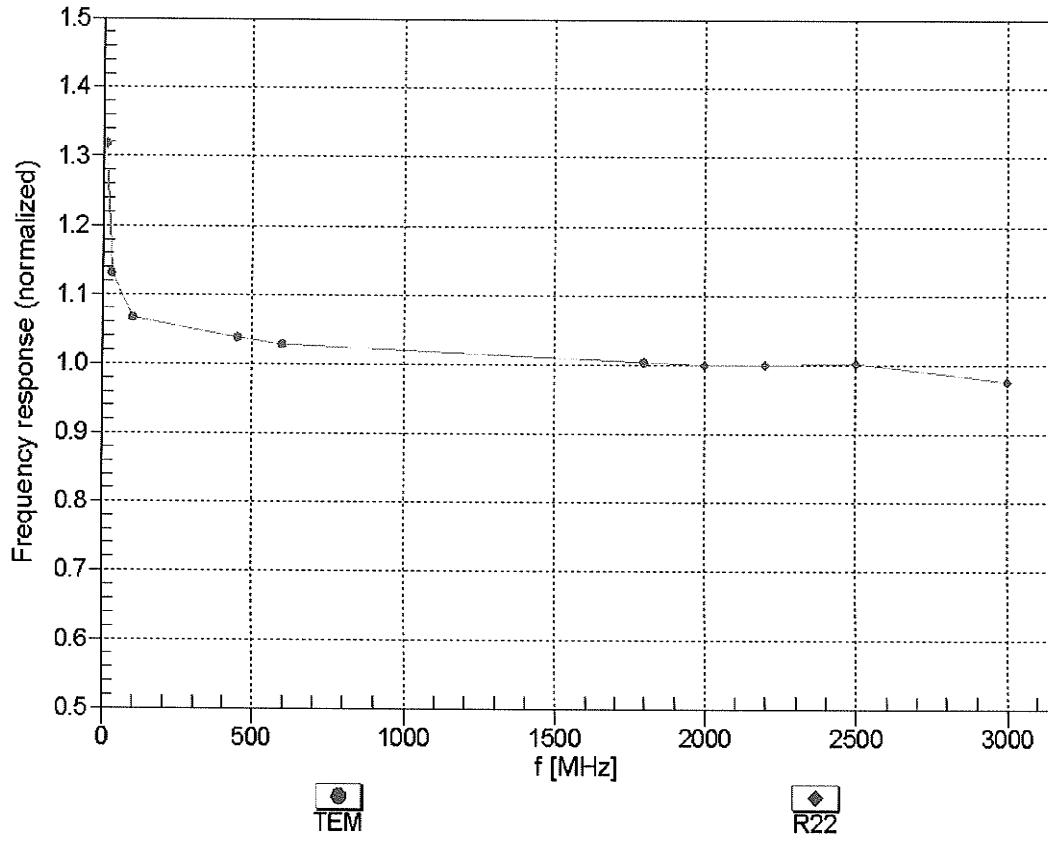

Uncertainty of Frequency Response of E-field: $\pm 6.3\%$ (k=2)

Receiving Pattern (ϕ), $\theta = 0^\circ$

f=600 MHz, TEM

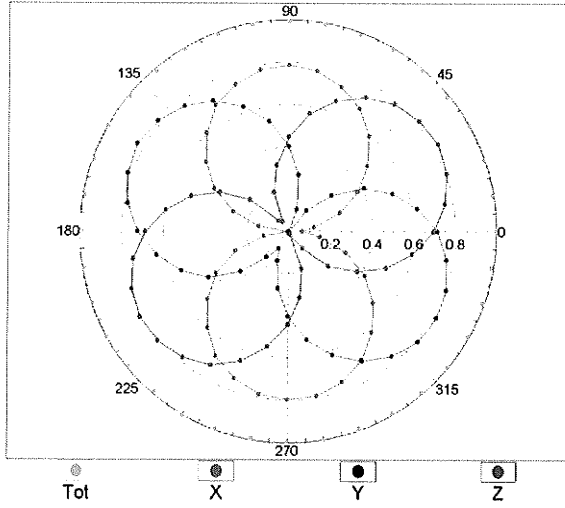

f=1800 MHz, R22

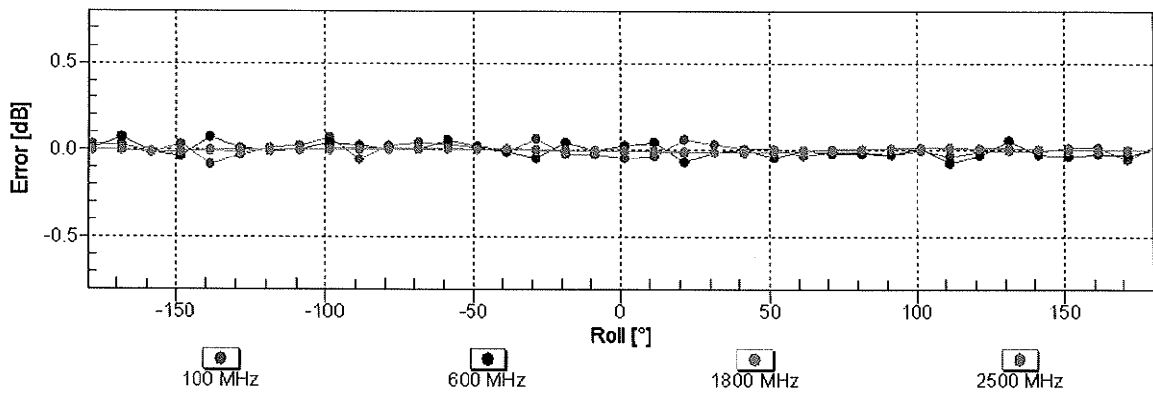
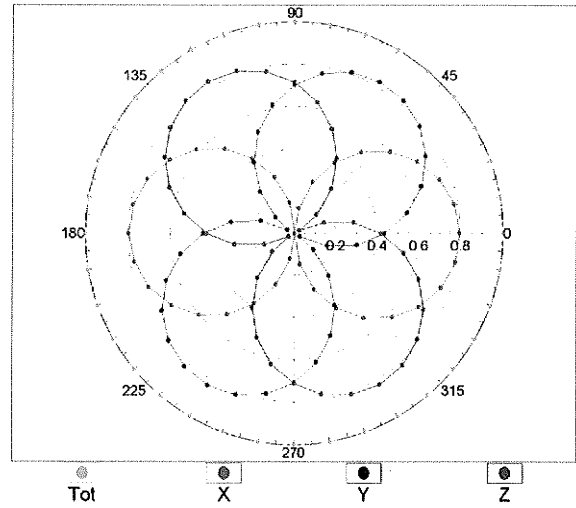

Uncertainty of Axial Isotropy Assessment: $\pm 0.5\%$ (k=2)

Dynamic Range $f(SAR_{head})$ (TEM cell , $f = 900$ MHz)

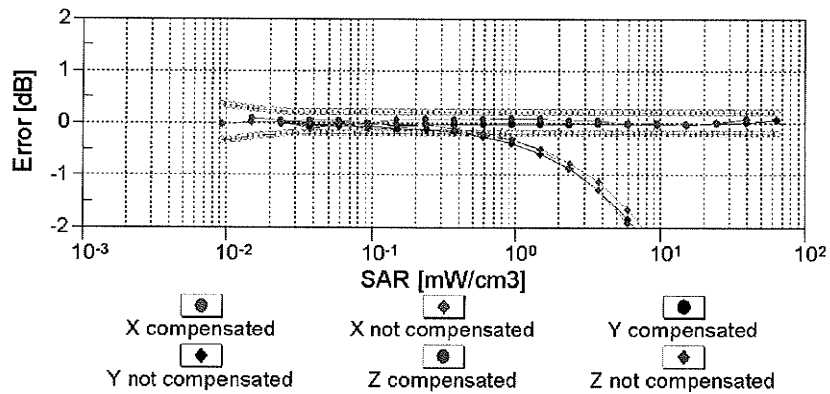
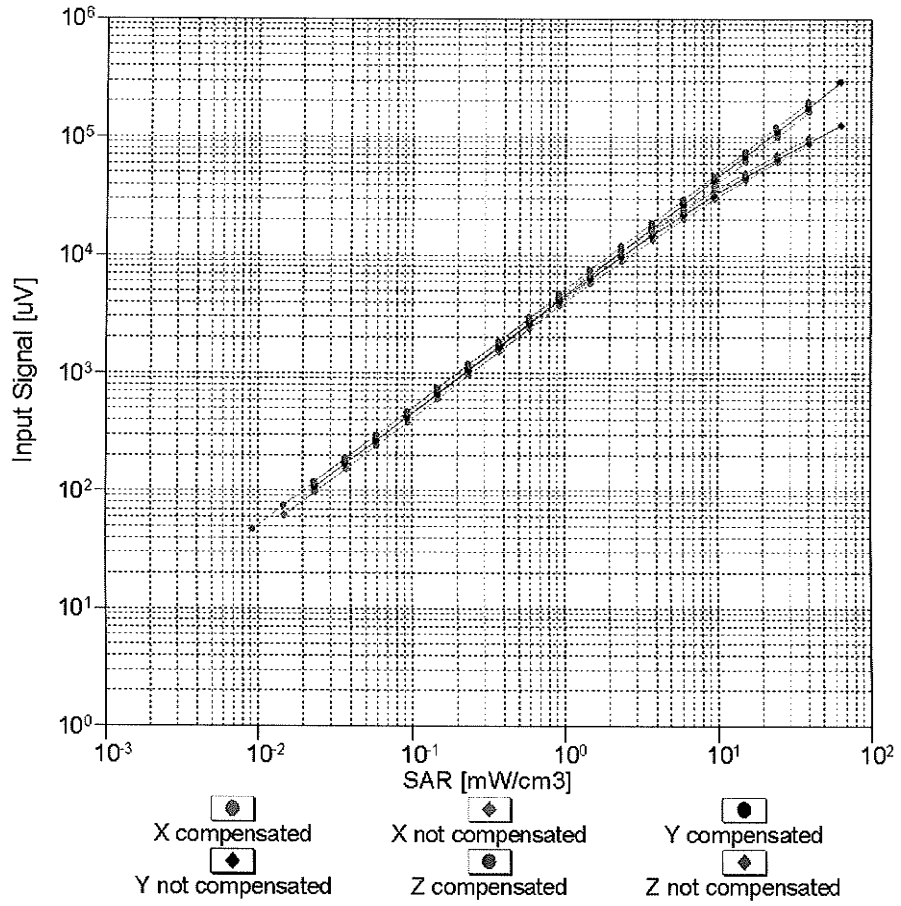

Uncertainty of Linearity Assessment: $\pm 0.6\%$ ($k=2$)

Conversion Factor Assessment

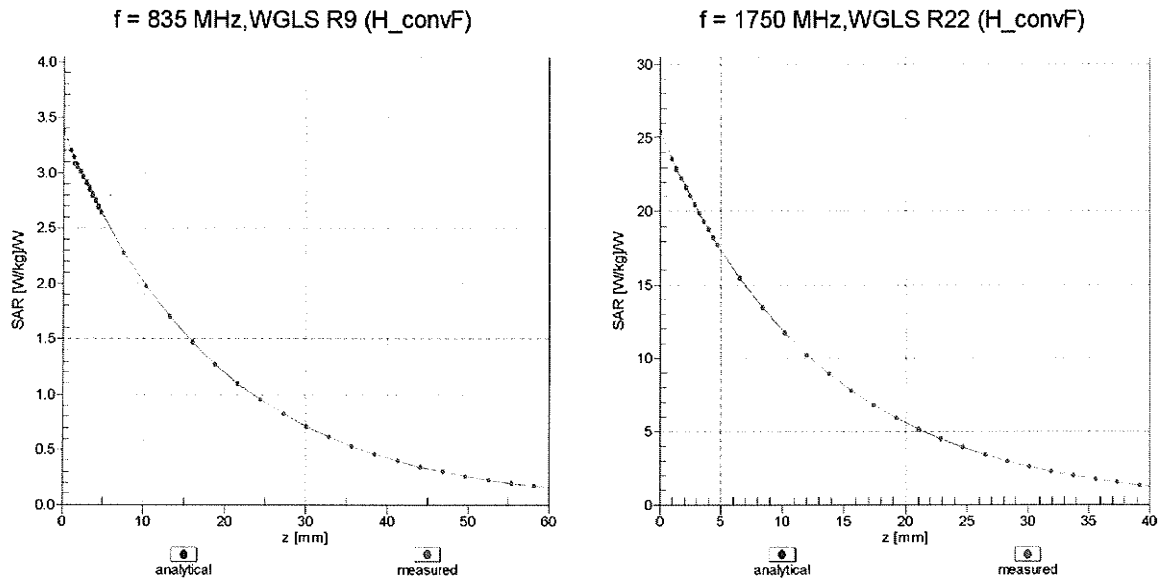

Deviation from Isotropy in Liquid

Error (ϕ, θ), f = 900 MHz

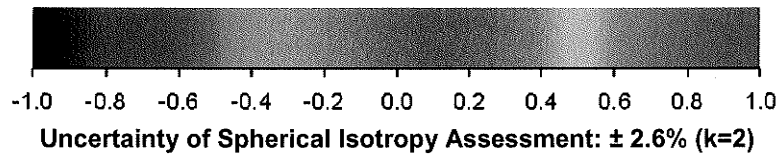
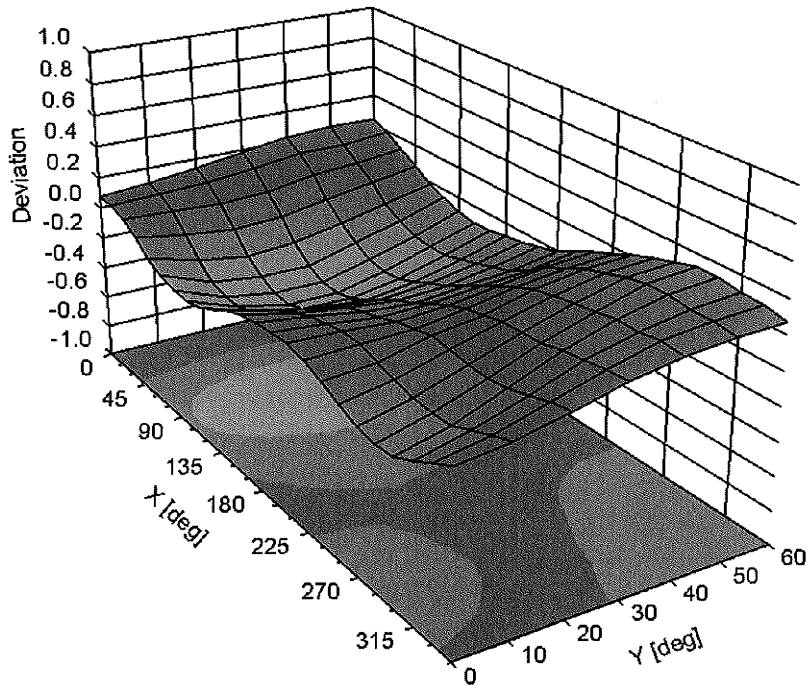

DASY/EASY - Parameters of Probe: EX3DV4 - SN:3650

Other Probe Parameters

Sensor Arrangement	Triangular
Connector Angle (°)	Not applicable
Mechanical Surface Detection Mode	enabled
Optical Surface Detection Mode	disabled
Probe Overall Length	337 mm
Probe Body Diameter	10 mm
Tip Length	9 mm
Tip Diameter	2.5 mm
Probe Tip to Sensor X Calibration Point	1 mm
Probe Tip to Sensor Y Calibration Point	1 mm
Probe Tip to Sensor Z Calibration Point	1 mm
Recommended Measurement Distance from Surface	2 mm



Accredited by the Swiss Accreditation Service (SAS)
The Swiss Accreditation Service is one of the signatories to the EA
Multilateral Agreement for the recognition of calibration certificates

Accreditation No.: **SCS 108**

Client **B.V.ADT (Auden)**

Certificate No: **EX3-3590_Feb12**

CALIBRATION CERTIFICATE

Object **EX3DV4 - SN:3590**

Calibration procedure(s) **QA CAL-01.v8, QA CAL-14.v3, QA CAL-23.v4, QA CAL-25.v4
Calibration procedure for dosimetric E-field probes**

Calibration date: **February 23, 2012**

This calibration certificate documents the traceability to national standards, which realize the physical units of measurements (SI).
The measurements and the uncertainties with confidence probability are given on the following pages and are part of the certificate.

All calibrations have been conducted in the closed laboratory facility: environment temperature (22 ± 3)°C and humidity < 70%.

Calibration Equipment used (M&TE critical for calibration)

Primary Standards	ID	Cal Date (Certificate No.)	Scheduled Calibration
Power meter E4419B	GB41293874	31-Mar-11 (No. 217-01372)	Apr-12
Power sensor E4412A	MY41498087	31-Mar-11 (No. 217-01372)	Apr-12
Reference 3 dB Attenuator	SN: S5054 (3c)	29-Mar-11 (No. 217-01369)	Apr-12
Reference 20 dB Attenuator	SN: S5086 (20b)	29-Mar-11 (No. 217-01367)	Apr-12
Reference 30 dB Attenuator	SN: S5129 (30b)	29-Mar-11 (No. 217-01370)	Apr-12
Reference Probe ES3DV2	SN: 3013	29-Dec-11 (No. ES3-3013_Dec11)	Dec-12
DAE4	SN: 654	3-May-11 (No. DAE4-654_May11)	May-12
Secondary Standards	ID	Check Date (in house)	Scheduled Check
RF generator HP 8648C	US3642U01700	4-Aug-99 (in house check Apr-11)	In house check: Apr-13
Network Analyzer HP 8753E	US37390585	18-Oct-01 (in house check Oct-11)	In house check: Oct-12

	Name	Function	Signature
Calibrated by:	Jeton Kastrati	Laboratory Technician	
Approved by:	Katja Pokovic	Technical Manager	

Issued: February 23, 2012

This calibration certificate shall not be reproduced except in full without written approval of the laboratory.



Accredited by the Swiss Accreditation Service (SAS)

Accreditation No.: **SCS 108**

The Swiss Accreditation Service is one of the signatories to the EA
Multilateral Agreement for the recognition of calibration certificates

Glossary:

TSL	tissue simulating liquid
NORM _{x,y,z}	sensitivity in free space
ConvF	sensitivity in TSL / NORM _{x,y,z}
DCP	diode compression point
CF	crest factor (1/duty_cycle) of the RF signal
A, B, C	modulation dependent linearization parameters
Polarization ϕ	ϕ rotation around probe axis
Polarization ϑ	ϑ rotation around an axis that is in the plane normal to probe axis (at measurement center), i.e., $\vartheta = 0$ is normal to probe axis

Calibration is Performed According to the Following Standards:

- IEEE Std 1528-2003, "IEEE Recommended Practice for Determining the Peak Spatial-Averaged Specific Absorption Rate (SAR) in the Human Head from Wireless Communications Devices: Measurement Techniques", December 2003
- IEC 62209-1, "Procedure to measure the Specific Absorption Rate (SAR) for hand-held devices used in close proximity to the ear (frequency range of 300 MHz to 3 GHz)", February 2005

Methods Applied and Interpretation of Parameters:

- NORM_{x,y,z}**: Assessed for E-field polarization $\vartheta = 0$ ($f \leq 900$ MHz in TEM-cell; $f > 1800$ MHz: R22 waveguide). NORM_{x,y,z} are only intermediate values, i.e., the uncertainties of NORM_{x,y,z} does not affect the E²-field uncertainty inside TSL (see below *ConvF*).
- NORM(f)_{x,y,z}** = NORM_{x,y,z} * frequency_response (see Frequency Response Chart). This linearization is implemented in DASY4 software versions later than 4.2. The uncertainty of the frequency response is included in the stated uncertainty of *ConvF*.
- DCP_{x,y,z}**: DCP are numerical linearization parameters assessed based on the data of power sweep with CW signal (no uncertainty required). DCP does not depend on frequency nor media.
- PAR**: PAR is the Peak to Average Ratio that is not calibrated but determined based on the signal characteristics
- A_{x,y,z}; B_{x,y,z}; C_{x,y,z}; VR_{x,y,z}**: A, B, C are numerical linearization parameters assessed based on the data of power sweep for specific modulation signal. The parameters do not depend on frequency nor media. VR is the maximum calibration range expressed in RMS voltage across the diode.
- ConvF and Boundary Effect Parameters**: Assessed in flat phantom using E-field (or Temperature Transfer Standard for $f \leq 800$ MHz) and inside waveguide using analytical field distributions based on power measurements for $f > 800$ MHz. The same setups are used for assessment of the parameters applied for boundary compensation (alpha, depth) of which typical uncertainty values are given. These parameters are used in DASY4 software to improve probe accuracy close to the boundary. The sensitivity in TSL corresponds to NORM_{x,y,z} * ConvF whereby the uncertainty corresponds to that given for ConvF. A frequency dependent ConvF is used in DASY version 4.4 and higher which allows extending the validity from ± 50 MHz to ± 100 MHz.
- Spherical isotropy (3D deviation from isotropy)**: in a field of low gradients realized using a flat phantom exposed by a patch antenna.
- Sensor Offset**: The sensor offset corresponds to the offset of virtual measurement center from the probe tip (on probe axis). No tolerance required.

Probe EX3DV4

SN:3590

Manufactured: March 23, 2009
Calibrated: February 23, 2012

Calibrated for DASY/EASY Systems
(Note: non-compatible with DASY2 system!)

DASY/EASY - Parameters of Probe: EX3DV4 - SN:3590

Basic Calibration Parameters

	Sensor X	Sensor Y	Sensor Z	Unc (k=2)
Norm ($\mu\text{V}/(\text{V}/\text{m})^2$) ^A	0.48	0.48	0.50	$\pm 10.1 \%$
DCP (mV) ^B	96.3	97.6	94.0	

Modulation Calibration Parameters

UID	Communication System Name	PAR		A dB	B dB	C dB	VR mV	Unc ^E (k=2)
10000	CW	0.00	X	0.00	0.00	1.00	106.2	$\pm 2.5 \%$
			Y	0.00	0.00	1.00	117.4	
			Z	0.00	0.00	1.00	109.0	

The reported uncertainty of measurement is stated as the standard uncertainty of measurement multiplied by the coverage factor $k=2$, which for a normal distribution corresponds to a coverage probability of approximately 95%.

^A The uncertainties of NormX,Y,Z do not affect the E²-field uncertainty inside TSL (see Pages 5 and 6).

^B Numerical linearization parameter: uncertainty not required.

^E Uncertainty is determined using the max. deviation from linear response applying rectangular distribution and is expressed for the square of the field value.

DASY/EASY - Parameters of Probe: EX3DV4 - SN:3590

Calibration Parameter Determined in Head Tissue Simulating Media

f (MHz) ^C	Relative Permittivity ^F	Conductivity (S/m) ^F	ConvF X	ConvF Y	ConvF Z	Alpha	Depth (mm)	Unct. (k=2)
750	41.9	0.89	10.62	10.62	10.62	0.43	0.80	± 12.0 %
835	41.5	0.90	10.14	10.14	10.14	0.18	1.26	± 12.0 %
900	41.5	0.97	10.11	10.11	10.11	0.44	0.75	± 12.0 %
1450	40.5	1.20	9.39	9.39	9.39	0.24	1.23	± 12.0 %
1640	40.3	1.29	9.18	9.18	9.18	0.80	0.56	± 12.0 %
1750	40.1	1.37	8.95	8.95	8.95	0.45	0.74	± 12.0 %
1810	40.0	1.40	8.79	8.79	8.79	0.66	0.61	± 12.0 %
1900	40.0	1.40	8.83	8.83	8.83	0.40	0.80	± 12.0 %
2000	40.0	1.40	8.65	8.65	8.65	0.49	0.70	± 12.0 %
2300	39.5	1.67	8.27	8.27	8.27	0.39	0.74	± 12.0 %
2450	39.2	1.80	7.88	7.88	7.88	0.35	0.83	± 12.0 %
2600	39.0	1.96	7.72	7.72	7.72	0.25	1.07	± 12.0 %
3500	37.9	2.91	7.77	7.77	7.77	0.33	1.11	± 13.1 %
5200	36.0	4.66	5.64	5.64	5.64	0.30	1.80	± 13.1 %
5300	35.9	4.76	5.32	5.32	5.32	0.30	1.80	± 13.1 %
5500	35.6	4.96	5.13	5.13	5.13	0.35	1.80	± 13.1 %
5600	35.5	5.07	4.89	4.89	4.89	0.40	1.80	± 13.1 %
5800	35.3	5.27	4.79	4.79	4.79	0.42	1.80	± 13.1 %

^C Frequency validity of ± 100 MHz only applies for DASY v4.4 and higher (see Page 2), else it is restricted to ± 50 MHz. The uncertainty is the RSS of the ConvF uncertainty at calibration frequency and the uncertainty for the indicated frequency band.

^F At frequencies below 3 GHz, the validity of tissue parameters (ϵ and σ) can be relaxed to ± 10% if liquid compensation formula is applied to measured SAR values. At frequencies above 3 GHz, the validity of tissue parameters (ϵ and σ) is restricted to ± 5%. The uncertainty is the RSS of the ConvF uncertainty for indicated target tissue parameters.

DASY/EASY - Parameters of Probe: EX3DV4 - SN:3590

Calibration Parameter Determined in Body Tissue Simulating Media

f (MHz) ^C	Relative Permittivity ^F	Conductivity (S/m) ^F	ConvF X	ConvF Y	ConvF Z	Alpha	Depth (mm)	Unct. (k=2)
750	55.5	0.96	10.61	10.61	10.61	0.30	0.99	± 12.0 %
835	55.2	0.97	10.47	10.47	10.47	0.48	0.74	± 12.0 %
900	55.0	1.05	10.40	10.40	10.40	0.63	0.66	± 12.0 %
1450	54.0	1.30	9.45	9.45	9.45	0.17	1.66	± 12.0 %
1640	53.8	1.40	9.47	9.47	9.47	0.36	0.94	± 12.0 %
1750	53.4	1.49	8.64	8.64	8.64	0.28	0.99	± 12.0 %
1810	53.3	1.52	8.27	8.27	8.27	0.31	0.94	± 12.0 %
1900	53.3	1.52	8.07	8.07	8.07	0.33	0.94	± 12.0 %
2000	53.3	1.52	8.19	8.19	8.19	0.41	0.82	± 12.0 %
2300	52.9	1.81	8.00	8.00	8.00	0.70	0.64	± 12.0 %
2450	52.7	1.95	7.80	7.80	7.80	0.80	0.55	± 12.0 %
2600	52.5	2.16	7.57	7.57	7.57	0.65	0.50	± 12.0 %
3500	51.3	3.31	7.18	7.18	7.18	0.49	0.87	± 13.1 %
5200	49.0	5.30	4.89	4.89	4.89	0.50	1.90	± 13.1 %
5300	48.9	5.42	4.81	4.81	4.81	0.48	1.90	± 13.1 %
5500	48.6	5.65	4.35	4.35	4.35	0.50	1.90	± 13.1 %
5600	48.5	5.77	3.92	3.92	3.92	0.65	1.90	± 13.1 %
5800	48.2	6.00	4.54	4.54	4.54	0.50	1.90	± 13.1 %

^C Frequency validity of ± 100 MHz only applies for DASY v4.4 and higher (see Page 2), else it is restricted to ± 50 MHz. The uncertainty is the RSS of the ConvF uncertainty at calibration frequency and the uncertainty for the indicated frequency band.

^F At frequencies below 3 GHz, the validity of tissue parameters (ϵ and σ) can be relaxed to ± 10% if liquid compensation formula is applied to measured SAR values. At frequencies above 3 GHz, the validity of tissue parameters (ϵ and σ) is restricted to ± 5%. The uncertainty is the RSS of the ConvF uncertainty for indicated target tissue parameters.

Frequency Response of E-Field

(TEM-Cell:ifi110 EXX, Waveguide: R22)

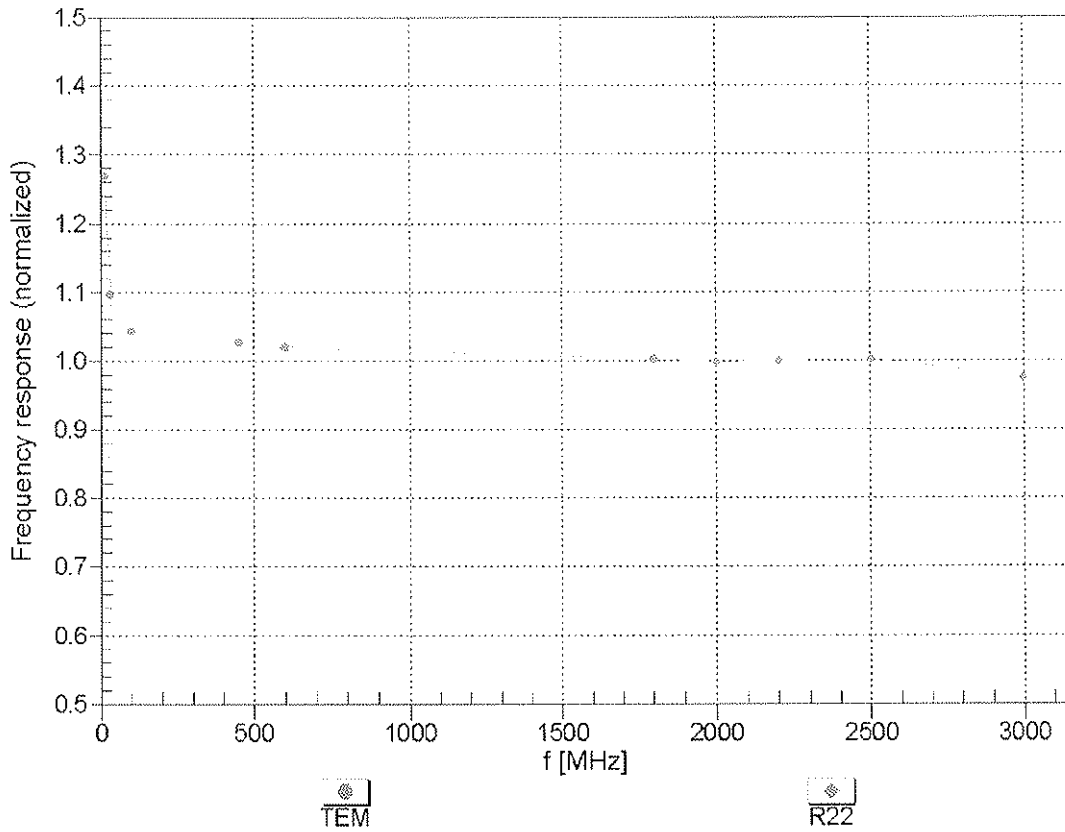

Uncertainty of Frequency Response of E-field: $\pm 6.3\%$ (k=2)

Receiving Pattern (ϕ), $\vartheta = 0^\circ$

f=600 MHz,TEM

f=1800 MHz,R22

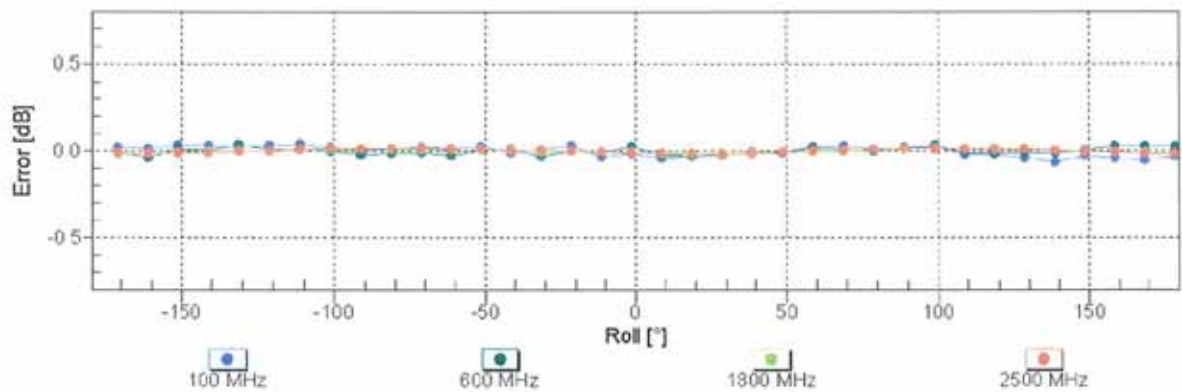
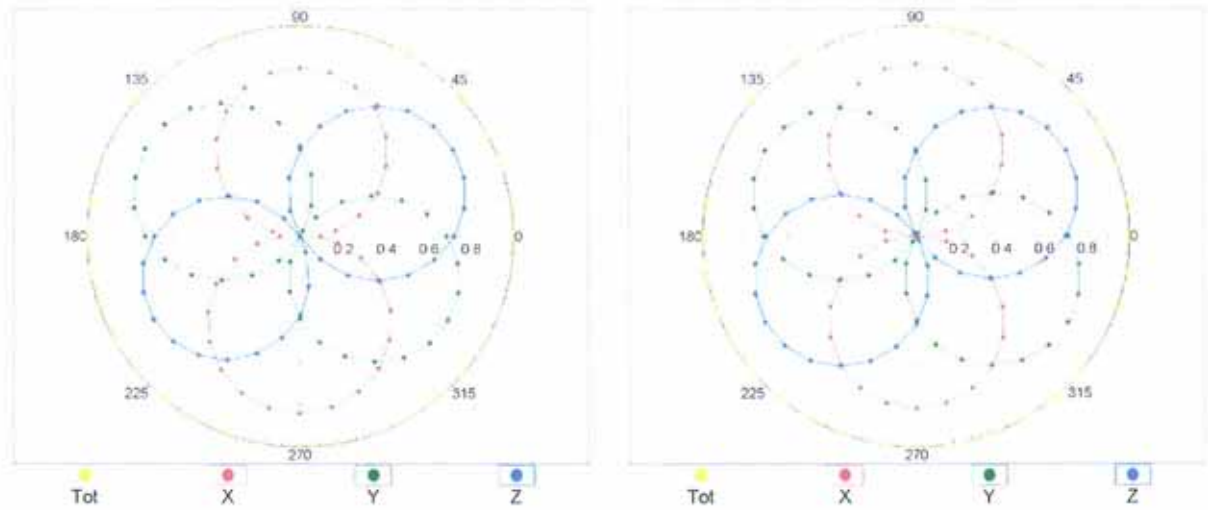

Uncertainty of Axial Isotropy Assessment: $\pm 0.5\%$ ($k=2$)

Dynamic Range f(SAR_{head}) (TEM cell , f = 900 MHz)

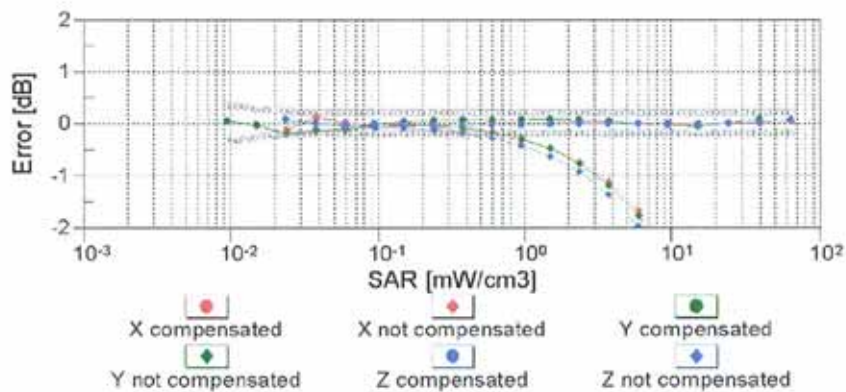
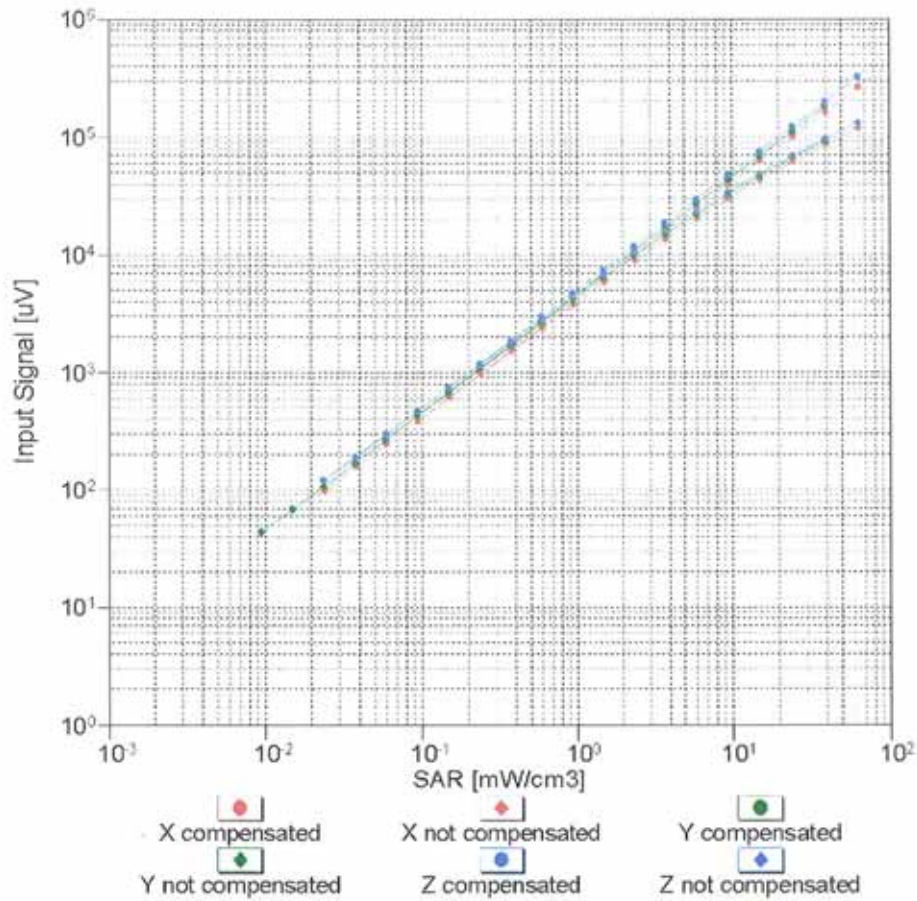

Uncertainty of Linearity Assessment: ± 0.6% (k=2)

Conversion Factor Assessment

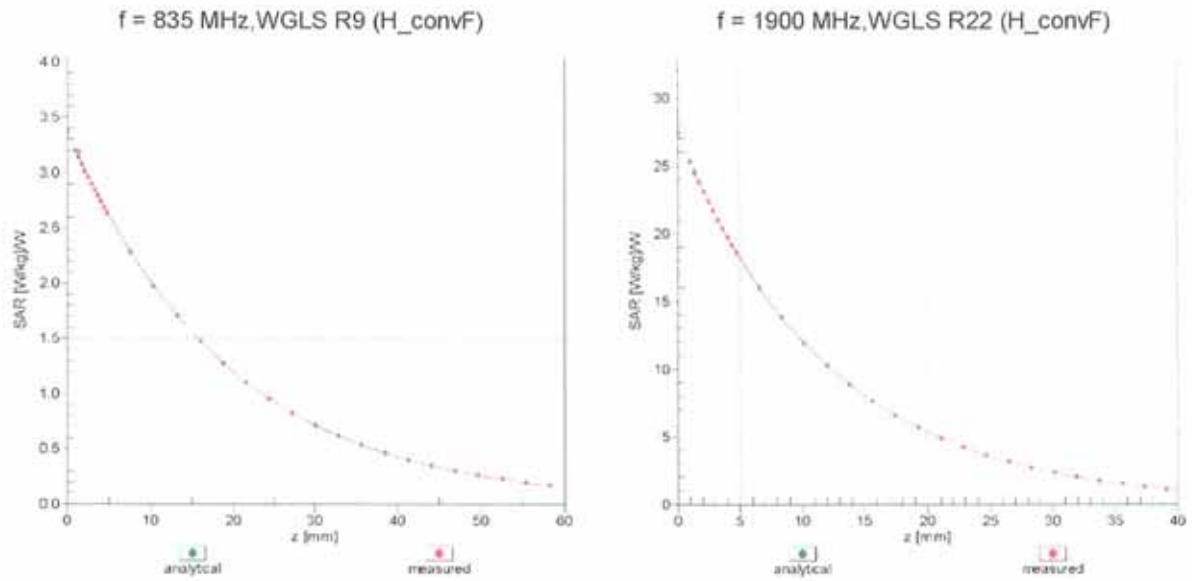

Deviation from Isotropy in Liquid Error (ϕ, ϑ), f = 900 MHz

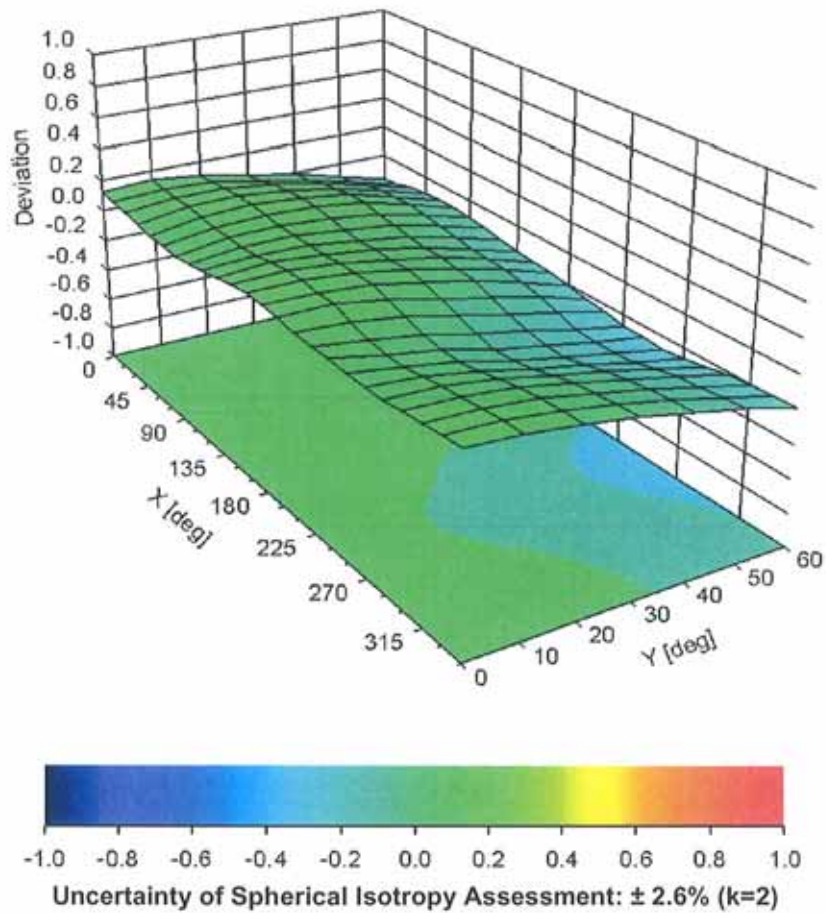

DASY/EASY - Parameters of Probe: EX3DV4 - SN:3590

Other Probe Parameters

Sensor Arrangement	Triangular
Connector Angle (°)	Not applicable
Mechanical Surface Detection Mode	enabled
Optical Surface Detection Mode	disabled
Probe Overall Length	337 mm
Probe Body Diameter	10 mm
Tip Length	9 mm
Tip Diameter	2.5 mm
Probe Tip to Sensor X Calibration Point	1 mm
Probe Tip to Sensor Y Calibration Point	1 mm
Probe Tip to Sensor Z Calibration Point	1 mm
Recommended Measurement Distance from Surface	2 mm



Accredited by the Swiss Accreditation Service (SAS)
The Swiss Accreditation Service is one of the signatories to the EA
Multilateral Agreement for the recognition of calibration certificates

Accreditation No.: **SCS 108**

Client **B.V. ADT (Auden)**

Certificate No: **EX3-3864_Jul12**

CALIBRATION CERTIFICATE

Object **EX3DV4 - SN:3864**

Calibration procedure(s) **QA CAL-01.v8, QA CAL-23.v4, QA CAL-25.v4
Calibration procedure for dosimetric E-field probes**

Calibration date: **July 19, 2012**

This calibration certificate documents the traceability to national standards, which realize the physical units of measurements (SI).
The measurements and the uncertainties with confidence probability are given on the following pages and are part of the certificate.

All calibrations have been conducted in the closed laboratory facility: environment temperature (22 ± 3)°C and humidity < 70%.

Calibration Equipment used (M&TE critical for calibration)

Primary Standards	ID	Cal Date (Certificate No.)	Scheduled Calibration
Power meter E4419B	GB41293874	29-Mar-12 (No. 217-01508)	Apr-13
Power sensor E4412A	MY41498087	29-Mar-12 (No. 217-01508)	Apr-13
Reference 3 dB Attenuator	SN: S5054 (3c)	27-Mar-12 (No. 217-01531)	Apr-13
Reference 20 dB Attenuator	SN: S5086 (20b)	27-Mar-12 (No. 217-01529)	Apr-13
Reference 30 dB Attenuator	SN: S5129 (30b)	27-Mar-12 (No. 217-01532)	Apr-13
Reference Probe ES3DV2	SN: 3013	29-Dec-11 (No. ES3-3013_Dec11)	Dec-12
DAE4	SN: 660	20-Jun-12 (No. DAE4-660_Jun12)	Jun-13
Secondary Standards	ID	Check Date (in house)	Scheduled Check
RF generator HP 8648C	US3642U01700	4-Aug-99 (in house check Apr-11)	In house check: Apr-13
Network Analyzer HP 8753E	US37390585	18-Oct-01 (in house check Oct-11)	In house check: Oct-12

Calibrated by:	Name Jeton Kastrat	Function Laboratory Technician	Signature
Approved by:	Name Katja Pokovic	Function Technical Manager	

Issued: July 20, 2012

This calibration certificate shall not be reproduced except in full without written approval of the laboratory.



Accredited by the Swiss Accreditation Service (SAS)

Accreditation No.: **SCS 108**

The Swiss Accreditation Service is one of the signatories to the EA
Multilateral Agreement for the recognition of calibration certificates

Glossary:

TSL	tissue simulating liquid
NORM _{x,y,z}	sensitivity in free space
ConvF	sensitivity in TSL / NORM _{x,y,z}
DCP	diode compression point
CF	crest factor (1/duty_cycle) of the RF signal
A, B, C	modulation dependent linearization parameters
Polarization ϕ	ϕ rotation around probe axis
Polarization ϑ	ϑ rotation around an axis that is in the plane normal to probe axis (at measurement center), i.e., $\vartheta = 0$ is normal to probe axis

Calibration is Performed According to the Following Standards:

- IEEE Std 1528-2003, "IEEE Recommended Practice for Determining the Peak Spatial-Averaged Specific Absorption Rate (SAR) in the Human Head from Wireless Communications Devices: Measurement Techniques", December 2003
- IEC 62209-1, "Procedure to measure the Specific Absorption Rate (SAR) for hand-held devices used in close proximity to the ear (frequency range of 300 MHz to 3 GHz)", February 2005

Methods Applied and Interpretation of Parameters:

- NORM_{x,y,z}**: Assessed for E-field polarization $\vartheta = 0$ ($f \leq 900$ MHz in TEM-cell; $f > 1800$ MHz: R22 waveguide). NORM_{x,y,z} are only intermediate values, i.e., the uncertainties of NORM_{x,y,z} does not affect the E²-field uncertainty inside TSL (see below *ConvF*).
- NORM(f)_{x,y,z} = NORM_{x,y,z} * frequency_response** (see Frequency Response Chart). This linearization is implemented in DASY4 software versions later than 4.2. The uncertainty of the frequency response is included in the stated uncertainty of *ConvF*.
- DCP_{x,y,z}**: DCP are numerical linearization parameters assessed based on the data of power sweep with CW signal (no uncertainty required). DCP does not depend on frequency nor media.
- PAR**: PAR is the Peak to Average Ratio that is not calibrated but determined based on the signal characteristics
- A_{x,y,z}; B_{x,y,z}; C_{x,y,z}; VR_{x,y,z}**: A, B, C are numerical linearization parameters assessed based on the data of power sweep for specific modulation signal. The parameters do not depend on frequency nor media. VR is the maximum calibration range expressed in RMS voltage across the diode.
- ConvF and Boundary Effect Parameters**: Assessed in flat phantom using E-field (or Temperature Transfer Standard for $f \leq 800$ MHz) and inside waveguide using analytical field distributions based on power measurements for $f > 800$ MHz. The same setups are used for assessment of the parameters applied for boundary compensation (alpha, depth) of which typical uncertainty values are given. These parameters are used in DASY4 software to improve probe accuracy close to the boundary. The sensitivity in TSL corresponds to NORM_{x,y,z} * ConvF whereby the uncertainty corresponds to that given for ConvF. A frequency dependent ConvF is used in DASY version 4.4 and higher which allows extending the validity from ± 50 MHz to ± 100 MHz.
- Spherical isotropy (3D deviation from isotropy)**: in a field of low gradients realized using a flat phantom exposed by a patch antenna.
- Sensor Offset**: The sensor offset corresponds to the offset of virtual measurement center from the probe tip (on probe axis). No tolerance required.

Probe EX3DV4

SN:3864

Manufactured: February 2, 2012
Calibrated: July 19, 2012

Calibrated for DASY/EASY Systems
(Note: non-compatible with DASY2 system!)

DASY/EASY - Parameters of Probe: EX3DV4 - SN:3864

Basic Calibration Parameters

	Sensor X	Sensor Y	Sensor Z	Unc (k=2)
Norm ($\mu\text{V}/(\text{V}/\text{m})^2$) ^A	0.47	0.44	0.49	$\pm 10.1 \%$
DCP (mV) ^B	97.6	98.0	97.9	

Modulation Calibration Parameters

UID	Communication System Name	PAR		A dB	B dB	C dB	VR mV	Unc ^E (k=2)
0	CW	0.00	X	0.00	0.00	1.00	154.8	$\pm 4.1 \%$
			Y	0.00	0.00	1.00	146.9	
			Z	0.00	0.00	1.00	162.0	

The reported uncertainty of measurement is stated as the standard uncertainty of measurement multiplied by the coverage factor $k=2$, which for a normal distribution corresponds to a coverage probability of approximately 95%.

^A The uncertainties of NormX,Y,Z do not affect the E^2 -field uncertainty inside TSL (see Pages 5 and 6).

^B Numerical linearization parameter: uncertainty not required.

^E Uncertainty is determined using the max. deviation from linear response applying rectangular distribution and is expressed for the square of the field value.

DASY/EASY - Parameters of Probe: EX3DV4 - SN:3864

Calibration Parameter Determined in Head Tissue Simulating Media

f (MHz) ^C	Relative Permittivity ^F	Conductivity (S/m) ^F	ConvF X	ConvF Y	ConvF Z	Alpha	Depth (mm)	Unct. (k=2)
835	41.5	0.90	9.80	9.80	9.80	0.58	0.65	± 12.0 %
1750	40.1	1.37	8.56	8.56	8.56	0.43	0.82	± 12.0 %
1900	40.0	1.40	8.13	8.13	8.13	0.42	0.79	± 12.0 %
2450	39.2	1.80	7.28	7.28	7.28	0.43	0.80	± 12.0 %

^C Frequency validity of ± 100 MHz only applies for DASY v4.4 and higher (see Page 2), else it is restricted to ± 50 MHz. The uncertainty is the RSS of the ConvF uncertainty at calibration frequency and the uncertainty for the indicated frequency band.

^F At frequencies below 3 GHz, the validity of tissue parameters (ϵ and σ) can be relaxed to ± 10% if liquid compensation formula is applied to measured SAR values. At frequencies above 3 GHz, the validity of tissue parameters (ϵ and σ) is restricted to ± 5%. The uncertainty is the RSS of the ConvF uncertainty for indicated target tissue parameters.

DASY/EASY - Parameters of Probe: EX3DV4 - SN:3864

Calibration Parameter Determined in Body Tissue Simulating Media

f (MHz) ^C	Relative Permittivity ^F	Conductivity (S/m) ^F	ConvF X	ConvF Y	ConvF Z	Alpha	Depth (mm)	Unct. (k=2)
835	55.2	0.97	9.94	9.94	9.94	0.58	0.72	± 12.0 %
1750	53.4	1.49	8.45	8.45	8.45	0.41	0.87	± 12.0 %
1900	53.3	1.52	7.88	7.88	7.88	0.48	0.77	± 12.0 %
2450	52.7	1.95	7.49	7.49	7.49	0.80	0.50	± 12.0 %

^C Frequency validity of ± 100 MHz only applies for DASY v4.4 and higher (see Page 2), else it is restricted to ± 50 MHz. The uncertainty is the RSS of the ConvF uncertainty at calibration frequency and the uncertainty for the indicated frequency band.

^F At frequencies below 3 GHz, the validity of tissue parameters (ϵ and σ) can be relaxed to ± 10% if liquid compensation formula is applied to measured SAR values. At frequencies above 3 GHz, the validity of tissue parameters (ϵ and σ) is restricted to ± 5%. The uncertainty is the RSS of the ConvF uncertainty for indicated target tissue parameters.

Frequency Response of E-Field (TEM-Cell:ifi110 EXX, Waveguide: R22)

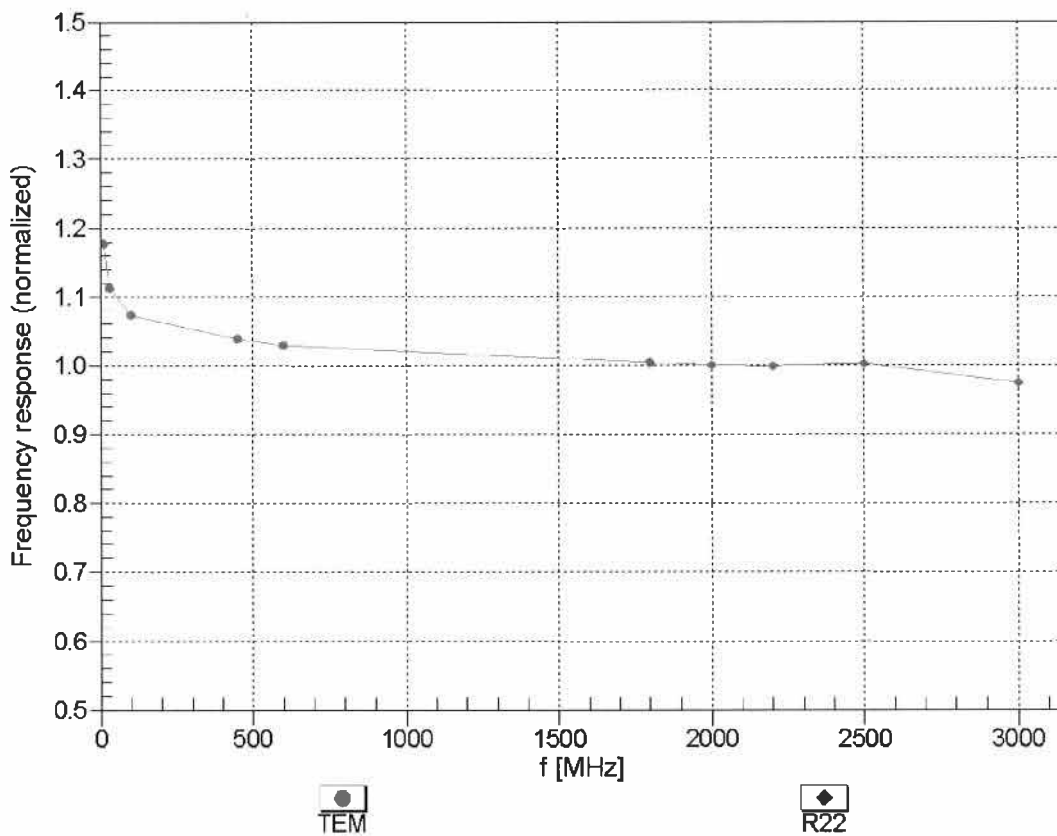

Uncertainty of Frequency Response of E-field: $\pm 6.3\%$ (k=2)

Receiving Pattern (ϕ), $\theta = 0^\circ$

f=600 MHz,TEM

f=1800 MHz,R22

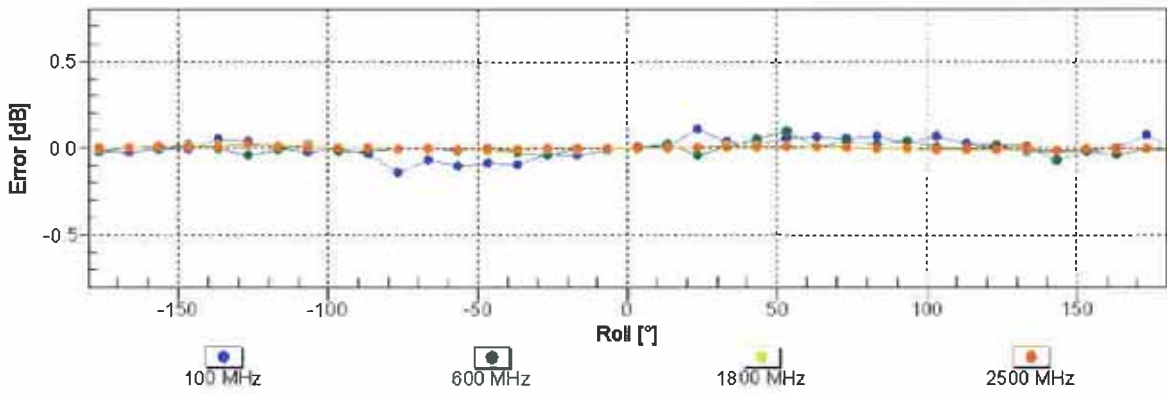
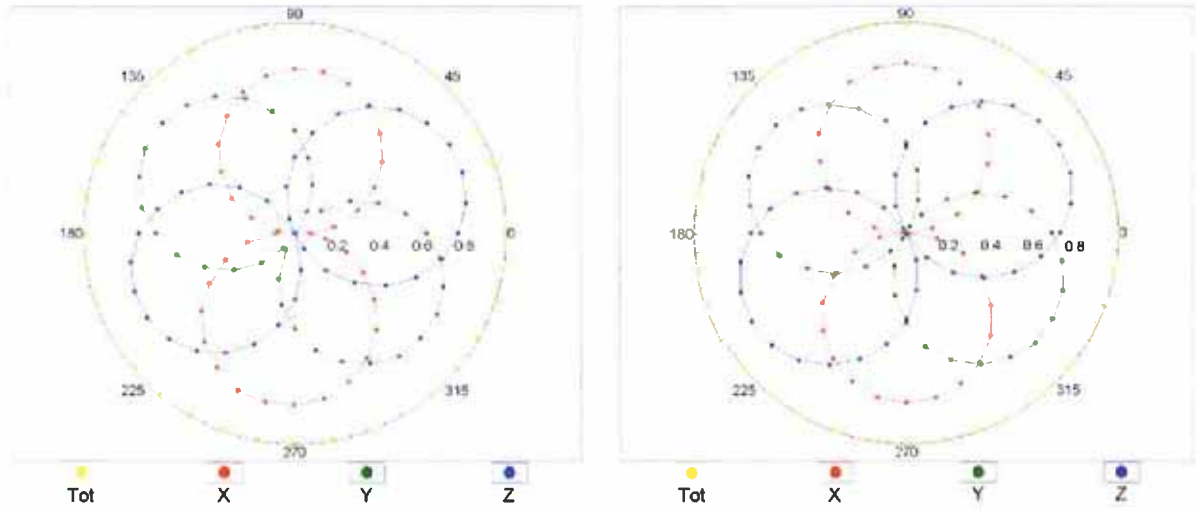

Uncertainty of Axial Isotropy Assessment: $\pm 0.5\%$ (k=2)

Dynamic Range f(SAR_{head}) (TEM cell , f = 900 MHz)

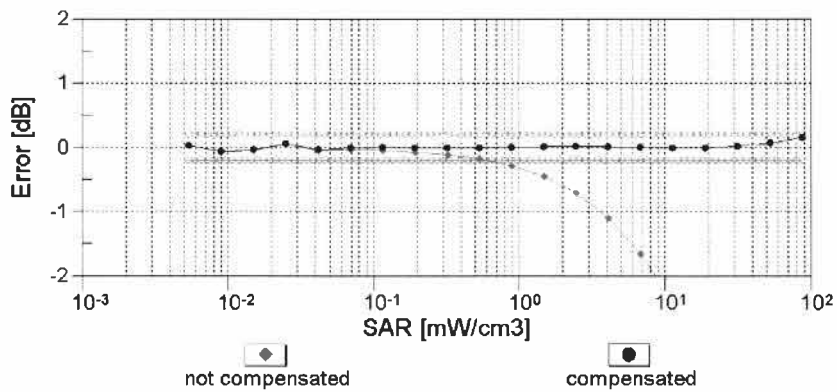
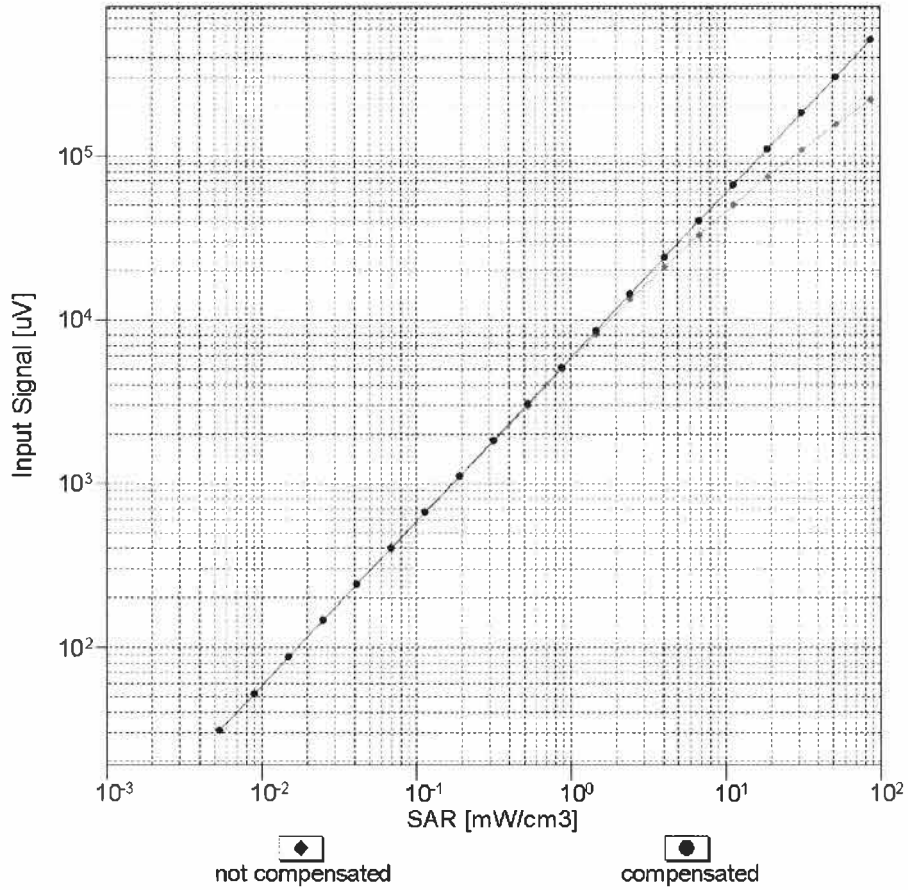

Uncertainty of Linearity Assessment: ± 0.6% (k=2)

Conversion Factor Assessment

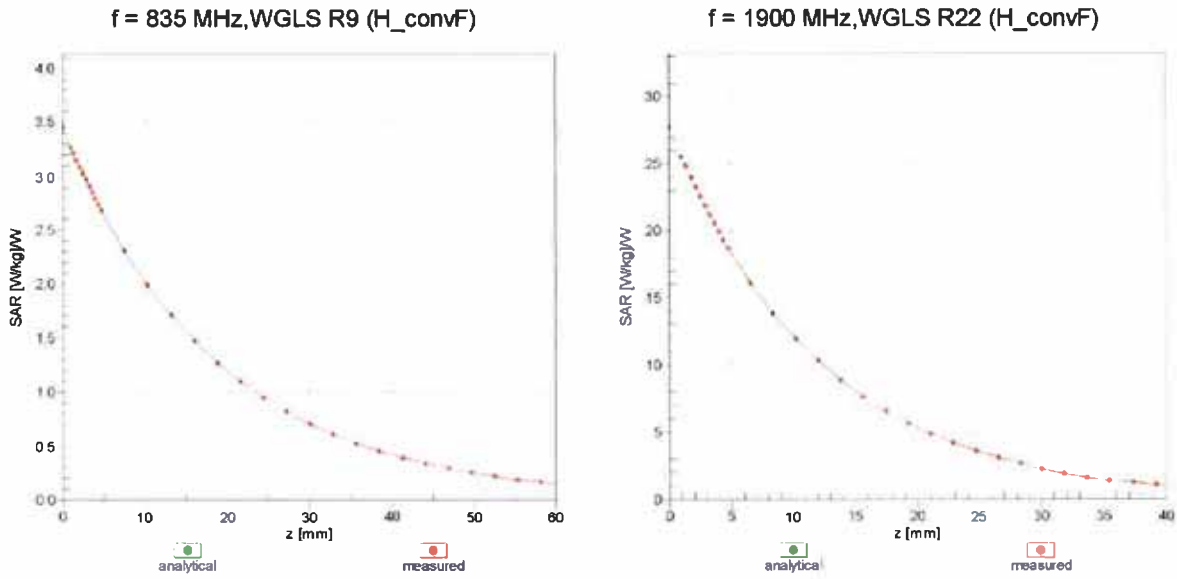

Deviation from Isotropy in Liquid Error (ϕ, ϑ), f = 900 MHz

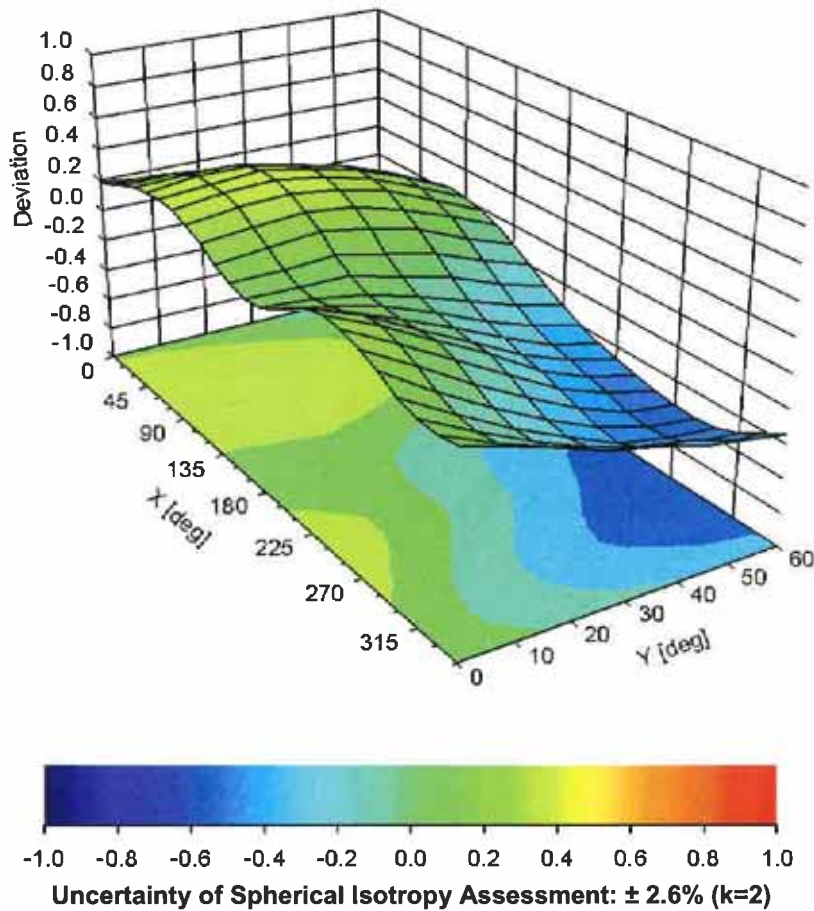

DASY/EASY - Parameters of Probe: EX3DV4 - SN:3864

Other Probe Parameters

Sensor Arrangement	Triangular
Connector Angle (°)	63.3
Mechanical Surface Detection Mode	enabled
Optical Surface Detection Mode	disabled
Probe Overall Length	337 mm
Probe Body Diameter	10 mm
Tip Length	9 mm
Tip Diameter	2.5 mm
Probe Tip to Sensor X Calibration Point	1 mm
Probe Tip to Sensor Y Calibration Point	1 mm
Probe Tip to Sensor Z Calibration Point	1 mm
Recommended Measurement Distance from Surface	2 mm



Appendix D. Photographs of EUT and Setup