



# FCC TEST REPORT (15.407)

**REPORT NO.:** RF120903C21-1  
**MODEL NO.:** MC40N0  
**FCC ID:** UZ7MC40N0  
**RECEIVED:** Jul. 20, 2012  
**TESTED:** Jul. 28 ~ Aug. 30, 2012  
**ISSUED:** Sep. 17, 2012

**APPLICANT:** Motorola Solutions, Inc.

**ADDRESS:** One Motorola Plaza, Holtsville, NY 11742-1300  
USA

**ISSUED BY:** Bureau Veritas Consumer Products Services  
(H.K.) Ltd., Taoyuan Branch

**LAB ADDRESS:** No. 47, 14th Ling, Chia Pau Vil., Lin Kou Dist.,  
New Taipei City, Taiwan ( R.O.C )

**TEST LOCATION:** No. 19, Hwa Ya 2nd Rd, Wen Hwa Tsuen, Kwei  
Shan Hsiang, Taoyuan Hsien 333, Taiwan, R.O.C.

This report should not be used by the client to claim product certification, approval, or endorsement by TAF or any government agencies.



This report is for your exclusive use. Any copying or replication of this report to or for any other person or entity, or use of our name or trademark, is permitted only with our prior written permission. This report sets forth our findings solely with respect to the test samples identified herein. The results set forth in this report are not indicative or representative of the quality or characteristics of the lot from which a test sample was taken or any similar or identical product unless specifically and expressly noted. Our report includes all of the tests requested by you and the results thereof based upon the information that you provided to us. You have 60 days from date of issuance of this report to notify us of any material error or omission caused by our negligence, provided, however, that such notice shall be in writing and shall specifically address the issue you wish to raise. A failure to raise such issue within the prescribed time shall constitute your unqualified acceptance of the completeness of this report, the tests conducted and the correctness of the report contents. Unless specific mention, the uncertainty of measurement has been explicitly taken into account to declare the compliance or non-compliance to the specification

## TABLE OF CONTENTS

RELEASE CONTROL RECORD .....	4
1. CERTIFICATION .....	5
2. SUMMARY OF TEST RESULTS .....	6
2.1 MEASUREMENT UNCERTAINTY .....	6
3. GENERAL INFORMATION .....	7
3.1 GENERAL DESCRIPTION OF EUT .....	7
3.2 DESCRIPTION OF TEST MODES .....	9
3.2.1 TEST MODE APPLICABILITY AND TESTED CHANNEL DETAIL .....	10
3.3 DESCRIPTION OF SUPPORT UNITS .....	12
3.3.1 CONFIGURATION OF SYSTEM UNDER TEST .....	13
3.4 DUTY CYCLE OF TEST SIGNAL .....	14
3.5 GENERAL DESCRIPTION OF APPLIED STANDARDS .....	14
4. TEST TYPES AND RESULTS .....	15
4.1 RADIATED EMISSION AND BANDEDGE MEASUREMENT .....	15
4.1.1 LIMITS OF RADIATED EMISSION AND BANDEDGE MEASUREMENT .....	15
4.1.2 LIMITS OF UNWANTED EMISSION OUT OF THE RESTRICTED BANDS .....	15
4.1.3 TEST INSTRUMENTS .....	16
4.1.4 TEST PROCEDURES .....	17
4.1.5 DEVIATION FROM TEST STANDARD .....	17
4.1.6 TEST SETUP .....	18
4.1.7 EUT OPERATING CONDITION .....	18
4.1.8 TEST RESULTS .....	19
4.2 CONDUCTED EMISSION MEASUREMENT .....	85
4.2.1 LIMITS OF CONDUCTED EMISSION MEASUREMENT .....	85
4.2.2 TEST INSTRUMENTS .....	85
4.2.3 TEST PROCEDURES .....	86
4.2.4 DEVIATION FROM TEST STANDARD .....	86
4.2.5 TEST SETUP .....	86
4.2.6 EUT OPERATING CONDITIONS .....	86
4.2.7 TEST RESULTS .....	87
4.3 PEAK TRANSMIT POWER MEASUREMENT .....	111
4.3.1 LIMITS OF PEAK TRANSMIT POWER MEASUREMENT .....	111
4.3.2 TEST SETUP .....	111
4.3.3 TEST INSTRUMENTS .....	111
4.3.4 TEST PROCEDURE .....	112
4.3.5 DEVIATION FROM TEST STANDARD .....	112
4.3.6 EUT OPERATING CONDITIONS .....	112
4.3.7 TEST RESULTS .....	113
4.4 PEAK POWER SPECTRAL DENSITY MEASUREMENT .....	119
4.4.1 LIMITS OF PEAK POWER SPECTRAL DENSITY MEASUREMENT .....	119
4.4.2 TEST SETUP .....	119
4.4.3 TEST INSTRUMENTS .....	119
4.4.4 TEST PROCEDURES .....	119
4.4.5 DEVIATION FROM TEST STANDARD .....	119
4.4.6 EUT OPERATING CONDITIONS .....	119
4.4.7 TEST RESULTS .....	120
4.5 PEAK POWER EXCURSION MEASUREMENT .....	123



4.5.1	LIMITS OF PEAK POWER EXCURSION MEASUREMENT .....	123
4.5.2	TEST SETUP .....	123
4.5.3	TEST INSTRUMENTS.....	123
4.5.4	TEST PROCEDURE.....	123
4.5.5	DEVIATION FROM TEST STANDARD .....	123
4.5.6	EUT OPERATING CONDITIONS .....	123
4.5.7	TEST RESULTS .....	124
4.6	FREQUENCY STABILITY.....	130
4.6.1	LIMITS OF FREQUENCY STABILITY MEASUREMENT .....	130
4.6.2	TEST SETUP .....	130
4.6.3	TEST INSTRUMENTS.....	130
4.6.4	TEST PROCEDURE.....	131
4.6.5	DEVIATION FROM TEST STANDARD .....	131
4.6.6	EUT OPERATING CONDITION .....	131
4.6.7	TEST RESULTS .....	132
5.	PHOTOGRAPHS OF THE TEST CONFIGURATION .....	133
6.	INFORMATION ON THE TESTING LABORATORIES .....	134
7.	APPENDIX A - MODIFICATIONS RECORDERS FOR ENGINEERING CHANGES TO THE EUT BY THE LAB.....	135



A D T

## RELEASE CONTROL RECORD

ISSUE NO.	REASON FOR CHANGE	DATE ISSUED
RF120903C21-1	Original release	Sep. 17, 2012



# 1. CERTIFICATION

**PRODUCT:** Mobile Computer  
**MODEL NO.:** MC40N0  
**BRAND:** Motorola  
**APPLICANT:** Motorola Solutions, Inc.  
**TESTED:** Jul. 28 ~ Aug. 30, 2012  
**TEST SAMPLE:** ENGINEERING SAMPLE  
**STANDARDS:** **FCC Part 15, Subpart E (Section 15.407)**  
ANSI C63.10-2009

The above equipment (model: MC40N0) has been tested by **Bureau Veritas Consumer Products Services (H.K.) Ltd., Taoyuan Branch**, and found compliance with the requirement of the above standards. The test record, data evaluation & Equipment Under Test (EUT) configurations represented herein are true and accurate accounts of the measurements of the sample's EMC characteristics under the conditions specified in this report.

**PREPARED BY :**  , **DATE :** Sep. 17, 2012  
Polly Chien / Specialist

**APPROVED BY :**  , **DATE :** Sep. 17, 2012  
Gary Chang / Technical Manager

## 2. SUMMARY OF TEST RESULTS

The EUT has been tested according to the following specifications:

APPLIED STANDARD: FCC PART 15, SUBPART E (SECTION 15.407)			
STANDARD SECTION	TEST TYPE	RESULT	REMARK
15.407(b)(6)	AC Power Conducted Emission	PASS	Meet the requirement of limit. Minimum passing margin is -5.61dB at 0.30772MHz.
15.407(b/1/2/3) (b)(6)	Spurious Emissions	PASS	Meet the requirement of limit. Minimum passing margin is -1.0dB at 5350.00MHz, 5470.00MHz & 5725.00MHz
15.407(a/1/2)	Peak Transmit Power	PASS	Meet the requirement of limit.
15.407(a)(6)	Peak Power Excursion	PASS	Meet the requirement of limit.
15.407(a/1/2)	Peak Power Spectral Density	PASS	Meet the requirement of limit.
15.407(g)	Frequency Stability	PASS	Meet the requirement of limit.
15.203	Antenna Requirement	PASS	No antenna connector is used.

### 2.1 MEASUREMENT UNCERTAINTY

Where relevant, the following measurement uncertainty levels have been estimated for tests performed on the EUT as specified in CISPR 16-4-2:

MEASUREMENT	FREQUENCY	UNCERTAINTY
Conducted emissions	9kHz~30MHz	2.44 dB
Radiated emissions	30MHz ~ 200MHz	2.93 dB
	200MHz ~1000MHz	2.95 dB
	1GHz ~ 18GHz	2.26 dB
	18GHz ~ 40GHz	1.94 dB

This uncertainty represents an expanded uncertainty expressed at approximately the 95% confidence level using a coverage factor of  $k = 2$ .

### 3. GENERAL INFORMATION

#### 3.1 GENERAL DESCRIPTION OF EUT

<b>EUT</b>	Mobile Computer
<b>MODEL NO.</b>	MC40N0
<b>POWER SUPPLY</b>	5Vdc (adapter or host equipment) 3.7Vdc (Li-ion battery)
<b>MODULATION TYPE</b>	64QAM, 16QAM, QPSK, BPSK
<b>MODULATION TECHNOLOGY</b>	OFDM
<b>TRANSFER RATE</b>	802.11a: 54.0/ 48.0/ 36.0/ 24.0/ 18.0/ 12.0/ 9.0/ 6.0Mbps 802.11n: up to 72.2Mbps
<b>OPERATING FREQUENCY</b>	5180 ~ 5240MHz, 5260 ~ 5320MHz & 5500 ~ 5700MHz
<b>NUMBER OF CHANNEL</b>	5180 ~ 5240MHz: 4 5260 ~ 5320MHz: 4 5500 ~ 5700MHz: 11
<b>OUTPUT POWER</b>	22.803mW for 5180 ~ 5240MHz 85.310mW for 5260 ~ 5320MHz 82.224mW for 5500 ~ 5700MHz
<b>ANTENNA TYPE</b>	Refer to Note as below
<b>ANTENNA CONNECTOR</b>	NA
<b>DATA CABLE</b>	Refer to Note as below
<b>I/O PORTS</b>	Refer to user's manual
<b>ACCESSORY DEVICES</b>	Battery
<b>SW</b>	Android 2.3.4 Build number 9927301-G-0500-0003-00-E2-072312
<b>HW</b>	EV2 (PCBA: 12H00-SD)

**NOTE:**

1. The device is available with or without MSR.
2. Antenna gain is listed as table below.

Configuration	Antenna type	Main antenna gain (dBi)		AUX antenna gain (dBi)	
		2.4GHz	5GHz	2.4GHz	5GHz
With MSR	PIFA	1.63	4.08	-0.15	5.44
Without MSR		1.72	4.01	-0.15	5.44

3. The following accessories are optional.

Item	Brand	Model	Specification
Adapter	Motorola	IU08-2050120-WP	I/P: 100-240Vac, 50/60Hz, 0.2A O/P: 5Vdc, 1.2A
Earphone	Motorola	NA	1.3m
Micro USB Cable	Motorola	25-MCXUSB-01R	1.5m



A D T

4. The EUT provides one completed transmitter and two receivers.

MODULATION MODE	TX FUNCTION
802.11b	1TX
802.11g	1TX
802.11a	1TX
802.11n (20MHz)	1TX

5. The EUT uses following battery.

Brand	Motorola
Rating	3.7Vdc,2680mAh, 9.91Wh

6. The above EUT information is declared by the manufacturer and for more detailed features description, please refer to the manufacturer's specifications or User's Manual.



### 3.2 DESCRIPTION OF TEST MODES

#### FOR 5180 ~ 5240MHz

4 channels are provided for 802.11a, 802.11n (20MHz):

CHANNEL	FREQUENCY	CHANNEL	FREQUENCY
36	5180 MHz	44	5220 MHz
40	5200 MHz	48	5240 MHz

#### FOR 5260 ~ 5320MHz

4 channels are provided for 802.11a, 802.11n (20MHz):

CHANNEL	FREQUENCY	CHANNEL	FREQUENCY
52	5260 MHz	60	5300 MHz
56	5280 MHz	64	5320 MHz

#### FOR 5500 ~ 5700MHz

11 channels are provided for 802.11a, 802.11n (20MHz):

CHANNEL	FREQUENCY	CHANNEL	FREQUENCY
100	5500MHz	124	5620MHz
104	5520MHz	128	5640MHz
108	5540MHz	132	5660MHz
112	5560MHz	136	5680MHz
116	5580MHz	140	5700MHz
120	5600MHz		

### 3.2.1 TEST MODE APPLICABILITY AND TESTED CHANNEL DETAIL

EUT CONFIGURE MODE	APPLICABLE TO				DESCRIPTIO	
	RE $\geq$ 1G	RE<1G	PLC	APCM	MSR /ANT.	Power Source
A1	√	√	√	√	with MSR Main Ant.	Power from adapter
A2	-	√	√	-		Power from host equipment
B1	√	√	√	√	without MSR Main Ant.	Power from adapter
B2	-	√	√	-		Power from host equipment
C1	√	√	√	√	without MSR Aux Ant.	Power from adapter
C2	-	√	√	-		Power from host equipment

Where **RE $\geq$ 1G**: Radiated Emission above 1GHz      **RE<1G**: Radiated Emission below 1GHz  
**PLC**: Power Line Conducted Emission      **APCM**: Antenna Port Conducted Measurement

**NOTE:**  
The EUT had been pre-tested on the positioned of each 3 axis. The worst case was found when positioned on **Z-plane**.  
**NOTE:** “-” means no effect.

#### **RADIATED EMISSION TEST (ABOVE 1GHz):**

- Pre-Scan has been conducted to determine the worst-case mode from all possible combinations between available modulations, data rates and antenna ports (if EUT with antenna diversity architecture).
- Following channel(s) was (were) selected for the final test as listed below.

EUT CONFIGURE MODE	MODE	FREQ. BAND (MHz)	AVAILABLE CHANNEL	TESTED CHANNEL	MODULATION TECHNOLOGY	MODULATION TYPE	DATA RATE (Mbps)
A1, B1, C1	802.11a	5180-5240	36 to 48	36, 40, 48	OFDM	BPSK	6.0
A1, B1, C1	802.11n (20MHz)						
A1, B1, C1	802.11a	5260-5320	52 to 64	52, 60, 64	OFDM	BPSK	6.0
A1, B1, C1	802.11n (20MHz)						
A1, B1, C1	802.11a	5500-5700	100 to 140	100, 116, 140	OFDM	BPSK	6.0
A1, B1, C1	802.11n (20MHz)						

#### **RADIATED EMISSION TEST (BELOW 1GHz):**

- Pre-Scan has been conducted to determine the worst-case mode from all possible combinations between available modulations, data rates and antenna ports (if EUT with antenna diversity architecture).
- Following channel(s) was (were) selected for the final test as listed below.

EUT CONFIGURE MODE	MODE	FREQ. BAND (MHz)	AVAILABLE CHANNEL	TESTED CHANNEL	MODULATION TECHNOLOGY	MODULATION TYPE	DATA RATE (Mbps)
A1, A2, B1, B2 C1, C2	802.11a	5180-5320	36 to 64	64	OFDM	BPSK	6.0
A1, A2, B1, B2 C1, C2	802.11a	5500-5700	100 to 140	116	OFDM	BPSK	6.0

**POWER LINE CONDUCTED EMISSION TEST:**

- Pre-Scan has been conducted to determine the worst-case mode from all possible combinations between available modulations, data rates and antenna ports (if EUT with antenna diversity architecture).
- Following channel(s) was (were) selected for the final test as listed below.

EUT CONFIGUR E MODE	MODE	FREQ. BAND (MHz)	AVAILABLE CHANNEL	TESTED CHANNEL	MODULATION TECHNOLOGY	MODULATION TYPE	DATA RATE (Mbps)
A1, A2, B1, B2 C1, C2	802.11a	5180-5320	36 to 64	64	OFDM	BPSK	6.0
A1, A2, B1, B2 C1, C2	802.11a	5500-5700	100 to 140	116	OFDM	BPSK	6.0

**ANTENNA PORT CONDUCTED MEASUREMENT:**

- This item includes all test value of each mode, but only includes spectrum plot of worst value of each mode.
- Pre-Scan has been conducted to determine the worst-case mode from all possible combinations between available modulations, data rates and antenna ports (if EUT with antenna diversity architecture).
- Following channel(s) was (were) selected for the final test as listed below.

EUT CONFIGUR E MODE	MODE	FREQ. BAND (MHz)	AVAILABLE CHANNEL	TESTED CHANNEL	MODULATION TECHNOLOGY	MODULATION TYPE	DATA RATE (Mbps)
A1, B1, C1	802.11a	5180-5240	36 to 48	36, 40, 48	OFDM	BPSK	6.0
A1, B1, C1	802.11n (20MHz)		36 to 48	36, 40, 48	OFDM	BPSK	6.5
A1, B1, C1	802.11a	5260-5320	52 to 64	52, 60, 64	OFDM	BPSK	6.0
A1, B1, C1	802.11n (20MHz)		52 to 64	52, 60, 64	OFDM	BPSK	6.5
A1, B1, C1	802.11a	5500-5700	100 to 140	100, 116, 140	OFDM	BPSK	6.0
A1, B1, C1	802.11n (20MHz)		100 to 140	100, 116, 140	OFDM	BPSK	6.5

**TEST CONDITION:**

APPLICABLE TO	ENVIRONMENTAL CONDITIONS	INPUT POWER	TESTED BY
RE≥1G	25deg. C, 65%RH	120Vac, 60Hz	Anderson Hong
RE<1G	25deg. C, 65%RH	120Vac, 60Hz	Anderson Hong
PLC	25deg. C, 65%RH	120Vac, 60Hz	Mark Liao
APCM	23deg. C, 63%RH	120Vac, 60Hz	Felix Soong

### 3.3 DESCRIPTION OF SUPPORT UNITS

The EUT has been tested as an independent unit together with other necessary accessories or support units. The following support units or accessories were used to form a representative test configuration during the tests.

NO.	PRODUCT	BRAND	MODEL NO.	SERIAL NO.	FCC ID
1	NOTEBOOK	DELL	E5420	33MLMQ1	Fcc DoC Approved
2	EARPHONE	PHILIPS	SBC HL150	NA	NA

NO.	SIGNAL CABLE DESCRIPTION OF THE ABOVE SUPPORT UNITS
1	NA
2	1.2m audio cable without core

**NOTE:** All power cords of the above support units are non shielded (1.8m).

### 3.3.1 CONFIGURATION OF SYSTEM UNDER TEST

**Test Mode A1 (With MSR & Main Ant.), B1 (Without MSR & Main Ant.),  
C1 (Without MSR & Aux Ant.)**

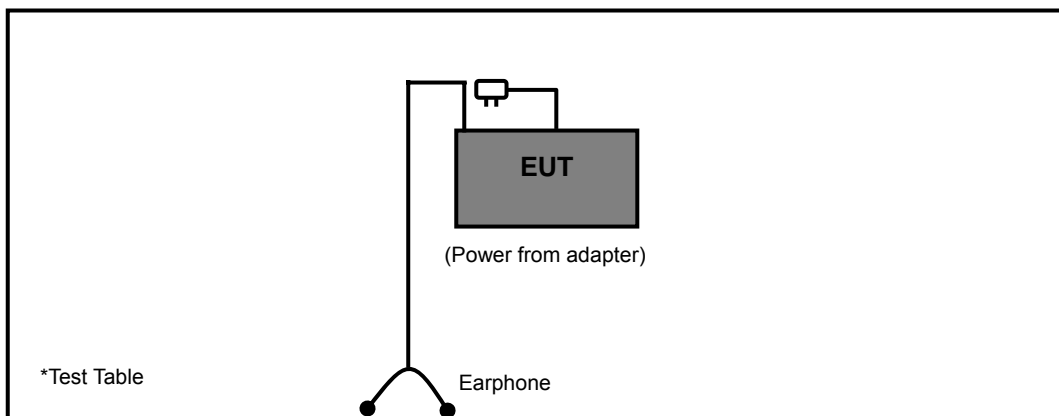

**Test Mode A2 (With MSR & Main Ant.), B2 (Without MSR & Main Ant.),  
C2 (Without MSR & Aux Ant.)**

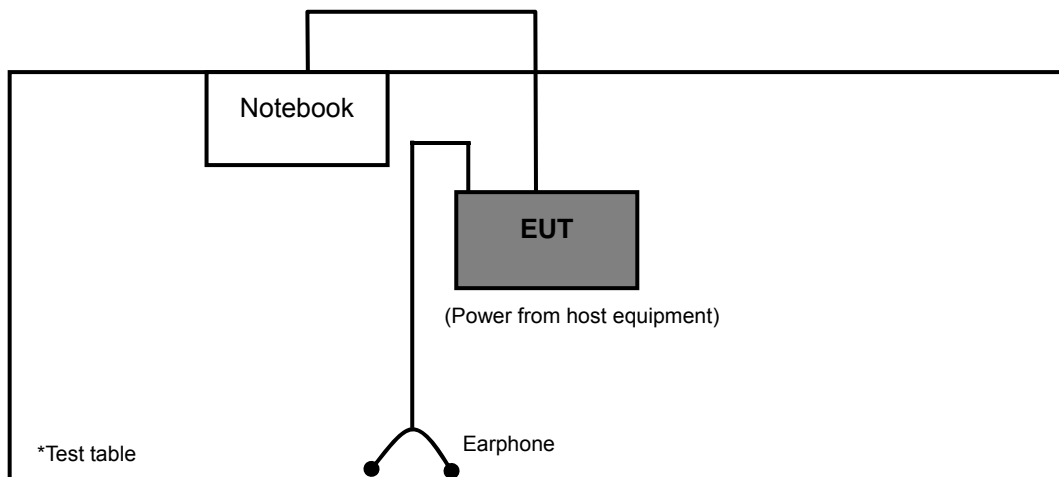

### 3.4 DUTY CYCLE OF TEST SIGNAL

Duty cycle of test signal is 100%, duty factor is not required.

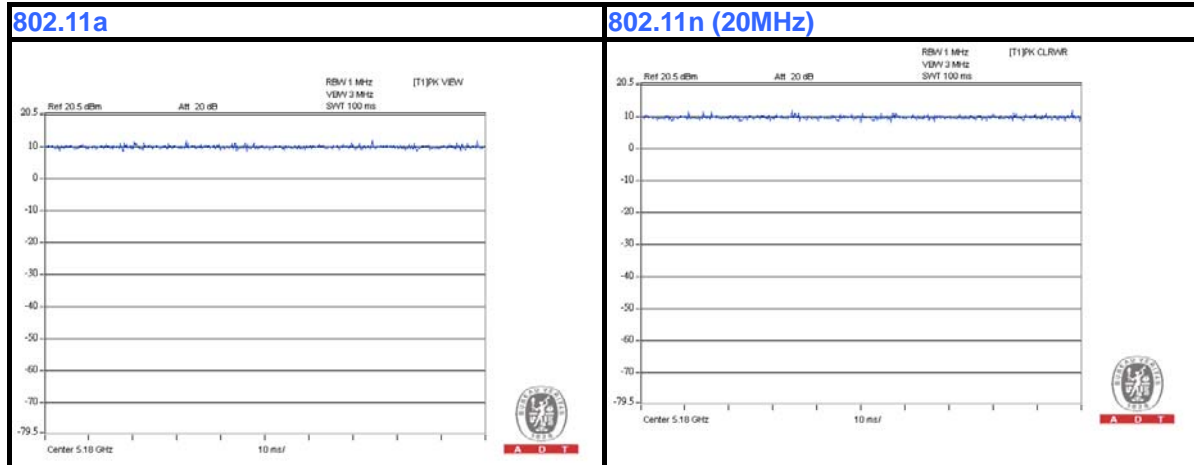

### 3.5 GENERAL DESCRIPTION OF APPLIED STANDARDS

The EUT is a RF Product. According to the specifications of the manufacturer, it must comply with the requirements of the following standards:

**FCC Part 15, Subpart E (15.407)**

ANSI C63.10-2009

KDB 789033 D01 General UNII Test Procedures v01r01

All test items have been performed and recorded as per the above standards.

## 4. TEST TYPES AND RESULTS

### 4.1 RADIATED EMISSION AND BANDEDGE MEASUREMENT

#### 4.1.1 LIMITS OF RADIATED EMISSION AND BANDEDGE MEASUREMENT

Radiated emissions which fall in the restricted bands must comply with the radiated emission limits specified as below table:

FREQUENCIES (MHz)	FIELD STRENGTH (microvolts/meter)	MEASUREMENT DISTANCE (meters)
0.009 ~ 0.490	2400/F(kHz)	300
0.490 ~ 1.705	24000/F(kHz)	30
1.705 ~ 30.0	30	30
30 ~ 88	100	3
88 ~ 216	150	3
216 ~ 960	200	3
Above 960	500	3

**NOTE:**

1. The lower limit shall apply at the transition frequencies.
2. Emission level (dBuV/m) = 20 log Emission level (uV/m).
3. For frequencies above 1000MHz, the field strength limits are based on average detector, however, the peak field strength of any emission shall not exceed the maximum permitted average limits, specified above by more than 20dB under any condition of modulation.

#### 4.1.2 LIMITS OF UNWANTED EMISSION OUT OF THE RESTRICTED BANDS

EIRP LIMIT (dBm)	EQUIVALENT FIELD STRENGTH AT 3m (dBµV/m)
<b>PK</b>	<b>PK</b>
-27	68.3

**NOTE:** The following formula is used to convert the equipment isotropic radiated power (eirp) to field strength:

$$E = \frac{1000000\sqrt{30P}}{3} \mu\text{V/m, where P is the eirp (Watts).}$$



#### 4.1.3 TEST INSTRUMENTS

DESCRIPTION & MANUFACTURER	MODEL NO.	SERIAL NO.	DATE OF CALIBRATION	DUE DATE OF CALIBRATION
Test Receiver Agilent	N9038A	MY51210203	Dec. 22, 2011	Dec. 21, 2012
Spectrum Analyzer ROHDE & SCHWARZ	FSU43	101261	Dec. 21, 2011	Dec. 20, 2012
BILOG Antenna SCHWARZBECK	VULB9168	9168-472	Dec. 20, 2011	Dec. 19, 2012
HORN Antenna SCHWARZBECK	BBHA 9120 D	9120D-969	Dec. 20, 2011	Dec. 19, 2012
HORN Antenna SCHWARZBECK	BBHA 9170	9170-480	Dec. 20, 2011	Dec. 19, 2012
Loop Antenna	HFH2-Z2	100070	Jan. 31, 2012	Jan. 30, 2014
Preamplifier EMCI	EMC 012645	980115	Dec. 30, 2011	Dec. 29, 2012
Preamplifier EMCI	EMC 330H	980112	Dec. 30, 2011	Dec. 29, 2012
RF signal cable HUBER+SUHNNER	SUCOFLEX 104	309219/4	Oct. 21, 2011	Oct. 20, 2012
RF signal cable HUBER+SUHNNER	SUCOFLEX 104	250130/4	Jan. 02, 2012	Jan. 01, 2013
RF signal cable Worken	RG-213	NA	Jan. 02, 2012	Jan. 01, 2013
Software	E3 6.120103	NA	NA	NA
Antenna Tower MF	MFA-440H	NA	NA	NA
Turn Table MF	MFT-201SS	NA	NA	NA
Antenna Tower & Turn Table Controller MF	MF-7802	NA	NA	NA
26GHz ~ 40GHz Amplifier	EM26400	815221	Oct. 29, 2011	Oct. 28, 2012
High Speed Peak Power Meter	ML2495A	0842014	Apr. 28, 2012	Apr. 27, 2013
Power Sensor	MA2411B	0738404	Apr. 28, 2012	Apr. 27, 2013

- NOTE:**
1. The calibration interval of the above test instruments is 12 months and the calibrations are traceable to NML/ROC and NIST/USA.
  2. The calibration interval of the loop antenna is 24 months and the calibrations are traceable to NML/ROC and NIST/USA.
  3. The test was performed in HwaYa Chamber 9.
  4. The horn antenna and HP preamplifier (model: 8449B) are used only for the measurement of emission frequency above 1GHz if tested.
  5. The FCC Site Registration No. is 460141.
  6. The IC Site Registration No. is IC 7450F-4.



#### 4.1.4 TEST PROCEDURES

- a. The EUT was placed on the top of a rotating table 0.8 meters above the ground at a 3 meter semi-anechoic chamber. The table was rotated 360 degrees to determine the position of the highest radiation.
- b. The EUT was set 3 meters away from the interference-receiving antenna, which was mounted on the top of a variable-height antenna tower.
- c. The antenna is a broadband antenna, and its height is varied from one meter to four meters above the ground to determine the maximum value of the field strength. Both horizontal and vertical polarizations of the antenna are set to make the measurement.
- d. For each suspected emission, the EUT was arranged to its worst case and then the antenna was tuned to heights from 1 meter to 4 meters and the rotatable table was turned from 0 degrees to 360 degrees to find the maximum reading.
- e. The test-receiver system was set to Peak Detect Function and Specified Bandwidth with Maximum Hold Mode.
- f. If the emission level of the EUT in peak mode was 10dB lower than the limit specified, then testing could be stopped and the peak values of the EUT would be reported. Otherwise the emissions that did not have 10dB margin would be re-tested one by one using peak, quasi-peak or average method as specified and then reported in a data sheet.

**NOTE:**

1. The resolution bandwidth and video bandwidth of test receiver/spectrum analyzer is 120kHz for Peak detection (PK) and Quasi-peak detection (QP) at frequency below 1GHz.
2. The resolution bandwidth of test receiver/spectrum analyzer is 1MHz and video bandwidth is 3MHz for Peak detection at frequency above 1GHz.
3. The resolution bandwidth of test receiver/spectrum analyzer is 1MHz and the video bandwidth is 1kHz for Average detection (AV) at frequency above 1GHz.
4. All modes of operation were investigated and the worst-case emissions are reported.

#### 4.1.5 DEVIATION FROM TEST STANDARD

No deviation.

#### 4.1.6 TEST SETUP

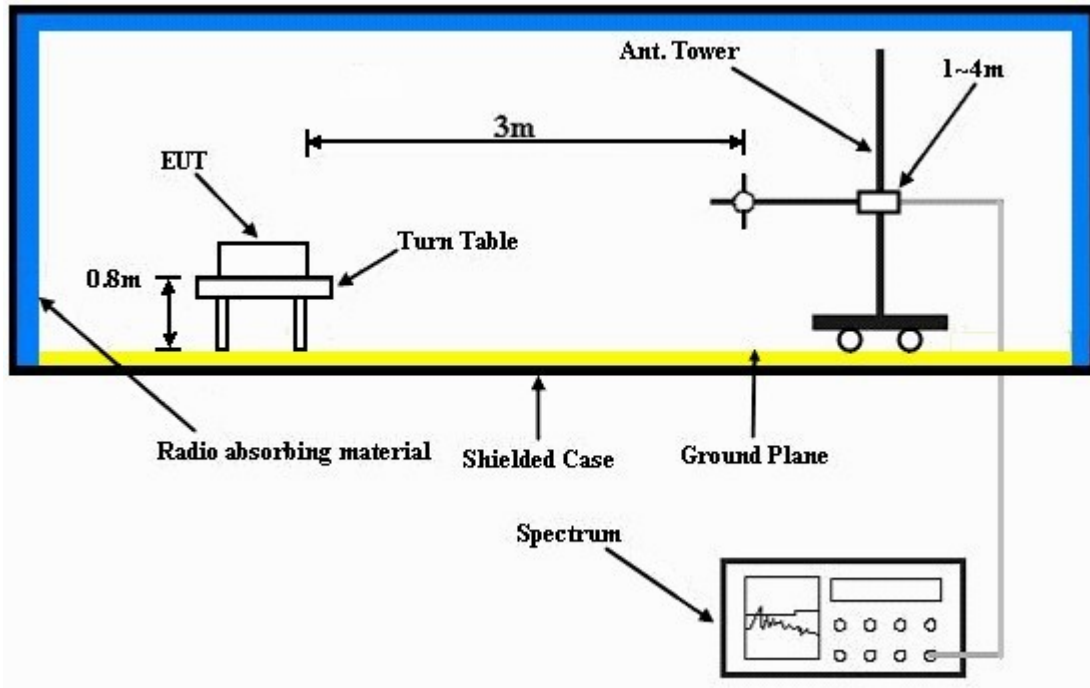

For the actual test configuration, please refer to the attached file (Test Setup Photo).

#### 4.1.7 EUT OPERATING CONDITION

##### **Test Mode A1 (With MSR & Main Ant.), B1 (Without MSR & Main Ant.), C1 (Without MSR & Aux Ant.)**

- Placed the EUT with earphone on testing table.
- Set the EUT under transmission condition continuously at specific channel frequency.

##### **Test Mode A2 (With MSR & Main Ant.), B2 (Without MSR & Main Ant.), C2 (Without MSR & Aux Ant.)**

- Connected the EUT to a notebook via USB cable and placed on a testing table.
- The EUT runs a test program (provided by manufacture) to transmit at specific channel.
- The necessary accessories enable the system in full functions.

#### 4.1.8 TEST RESULTS

##### ABOVE 1GHz WORST-CASE DATA:

##### Test Mode A1 (With MSR& Main Ant.)

802.11a

EUT TEST CONDITION		MEASUREMENT DETAIL	
CHANNEL	Channel 36	FREQUENCY RANGE	1 ~ 40GHz
INPUT POWER	120Vac, 60 Hz	DETECTOR FUNCTION	Peak (PK) Average (AV)
ENVIRONMENTAL CONDITIONS	25deg. C, 68%RH	TESTED BY	Anderson Hong

ANTENNA POLARITY & TEST DISTANCE: HORIZONTAL AT 3 M								
NO.	FREQ. (MHz)	EMISSION LEVEL (dBuV/m)	LIMIT (dBuV/m)	MARGIN (dB)	ANTENNA HEIGHT (m)	TABLE ANGLE (Degree)	RAW VALUE (dBuV)	CORRECTION FACTOR (dB/m)
1	5150.00	63.2 PK	74.0	-10.8	1.00 H	10	25.00	38.20
2	5150.00	46.0 AV	54.0	-8.0	1.00 H	10	7.80	38.20
3	*5180.00	101.4 PK			1.00 H	10	63.20	38.20
4	*5180.00	90.4 AV			1.00 H	10	52.20	38.20
5	#10360.00	53.3 PK	68.3	-15.0	1.00 H	86	5.30	48.00
ANTENNA POLARITY & TEST DISTANCE: VERTICAL AT 3 M								
NO.	FREQ. (MHz)	EMISSION LEVEL (dBuV/m)	LIMIT (dBuV/m)	MARGIN (dB)	ANTENNA HEIGHT (m)	TABLE ANGLE (Degree)	RAW VALUE (dBuV)	CORRECTION FACTOR (dB/m)
1	5150.00	53.9 PK	74.0	-20.1	1.00 V	321	15.70	38.20
2	5150.00	38.4 AV	54.0	-15.6	1.00 V	321	0.20	38.20
3	*5180.00	94.0 PK			1.00 V	321	55.80	38.20
4	*5180.00	83.1 AV			1.00 V	321	44.90	38.20
5	#10360.00	53.2 PK	68.3	-15.1	1.45 V	325	5.20	48.00

##### REMARKS:

1. Emission level (dBuV/m) = Raw Value (dBuV) + Correction Factor (dB/m).
2. Correction Factor (dB/m) = Antenna Factor (dB/m) + Cable Factor (dB).
3. The other emission levels were very low against the limit.
4. Margin value = Emission level – Limit value.
5. “ \* “: Fundamental frequency.
6. “#”:The radiated frequency is out the restricted band.



A D T

EUT TEST CONDITION		MEASUREMENT DETAIL	
CHANNEL	Channel 40	FREQUENCY RANGE	1 ~ 40GHz
INPUT POWER	120Vac, 60 Hz	DETECTOR FUNCTION	Peak (PK) Average (AV)
ENVIRONMENTAL CONDITIONS	25deg. C, 68%RH	TESTED BY	Anderson Hong

ANTENNA POLARITY & TEST DISTANCE: HORIZONTAL AT 3 M								
NO.	FREQ. (MHz)	EMISSION LEVEL (dBuV/m)	LIMIT (dBuV/m)	MARGIN (dB)	ANTENNA HEIGHT (m)	TABLE ANGLE (Degree)	RAW VALUE (dBuV)	CORRECTION FACTOR (dB/m)
1	*5200.00	101.5 PK			1.00 H	9	63.30	38.20
2	*5200.00	90.5 AV			1.00 H	9	52.30	38.20
3	#10400.00	53.6 PK	68.3	-14.7	1.00 H	80	5.50	48.10
4	15600.00	56.2 PK	74.0	-17.8	1.18 H	119	7.10	49.10
5	15600.00	43.2 AV	54.0	-10.8	1.18 H	119	-5.90	49.10
ANTENNA POLARITY & TEST DISTANCE: VERTICAL AT 3 M								
NO.	FREQ. (MHz)	EMISSION LEVEL (dBuV/m)	LIMIT (dBuV/m)	MARGIN (dB)	ANTENNA HEIGHT (m)	TABLE ANGLE (Degree)	RAW VALUE (dBuV)	CORRECTION FACTOR (dB/m)
1	*5200.00	94.2 PK			1.00 V	319	56.00	38.20
2	*5200.00	83.2 AV			1.00 V	319	45.00	38.20
3	#10400.00	53.6 PK	68.3	-14.7	1.41 V	321	5.50	48.10
4	15600.00	57.2 PK	74.0	-16.8	1.30 V	283	8.10	49.10
5	15600.00	43.5 AV	54.0	-10.5	1.30 V	283	-5.60	49.10

**REMARKS:**

1. Emission level (dBuV/m) = Raw Value (dBuV) + Correction Factor (dB/m).
2. Correction Factor (dB/m) = Antenna Factor (dB/m) + Cable Factor (dB).
3. The other emission levels were very low against the limit.
4. Margin value = Emission level – Limit value.
5. “ \* “: Fundamental frequency.
6. “#”:The radiated frequency is out the restricted band.



A D T

EUT TEST CONDITION		MEASUREMENT DETAIL	
CHANNEL	Channel 48	FREQUENCY RANGE	1 ~ 40GHz
INPUT POWER	120Vac, 60 Hz	DETECTOR FUNCTION	Peak (PK) Average (AV)
ENVIRONMENTAL CONDITIONS	25deg. C, 68%RH	TESTED BY	Anderson Hong

ANTENNA POLARITY & TEST DISTANCE: HORIZONTAL AT 3 M								
NO.	FREQ. (MHz)	EMISSION LEVEL (dBuV/m)	LIMIT (dBuV/m)	MARGIN (dB)	ANTENNA HEIGHT (m)	TABLE ANGLE (Degree)	RAW VALUE (dBuV)	CORRECTION FACTOR (dB/m)
1	*5240.00	103.0 PK			1.10 H	5	64.70	38.30
2	*5240.00	91.9 AV			1.10 H	5	53.60	38.30
3	5350.00	42.5 PK	74.0	-31.5	1.10 H	5	4.00	38.50
4	5350.00	30.4 AV	54.0	-23.6	1.10 H	5	-8.10	38.50
5	#10480.00	54.3 PK	68.3	-14.0	1.00 H	90	6.10	48.20
ANTENNA POLARITY & TEST DISTANCE: VERTICAL AT 3 M								
NO.	FREQ. (MHz)	EMISSION LEVEL (dBuV/m)	LIMIT (dBuV/m)	MARGIN (dB)	ANTENNA HEIGHT (m)	TABLE ANGLE (Degree)	RAW VALUE (dBuV)	CORRECTION FACTOR (dB/m)
1	*5240.00	95.4 PK			1.00 V	328	57.10	38.30
2	*5240.00	84.4 AV			1.00 V	328	46.10	38.30
3	5350.00	41.2 PK	74.0	-32.8	1.00 V	328	2.70	38.50
4	5350.00	29.1 AV	54.0	-24.9	1.00 V	328	-9.40	38.50
5	#10480.00	54.2 PK	68.3	-14.1	1.41 V	321	6.00	48.20

**REMARKS:**

1. Emission level (dBuV/m) = Raw Value (dBuV) + Correction Factor (dB/m).
2. Correction Factor (dB/m) = Antenna Factor (dB/m) + Cable Factor (dB).
3. The other emission levels were very low against the limit.
4. Margin value = Emission level – Limit value.
5. “ \* “: Fundamental frequency.
6. “#”:The radiated frequency is out the restricted band.



A D T

EUT TEST CONDITION		MEASUREMENT DETAIL	
CHANNEL	Channel 52	FREQUENCY RANGE	1 ~ 40GHz
INPUT POWER	120Vac, 60 Hz	DETECTOR FUNCTION	Peak (PK) Average (AV)
ENVIRONMENTAL CONDITIONS	25deg. C, 68%RH	TESTED BY	Anderson Hong

ANTENNA POLARITY & TEST DISTANCE: HORIZONTAL AT 3 M								
NO.	FREQ. (MHz)	EMISSION LEVEL (dBuV/m)	LIMIT (dBuV/m)	MARGIN (dB)	ANTENNA HEIGHT (m)	TABLE ANGLE (Degree)	RAW VALUE (dBuV)	CORRECTION FACTOR (dB/m)
1	5150.00	46.1 PK	74.0	-27.9	1.10 H	8	7.90	38.20
2	5150.00	33.8 AV	54.0	-20.2	1.10 H	8	-4.40	38.20
3	*5260.00	106.8 PK			1.10 H	8	68.50	38.30
4	*5260.00	95.8 AV			1.10 H	8	57.50	38.30
5	#10520.00	56.0 PK	68.3	-12.3	1.00 H	84	7.70	48.30
ANTENNA POLARITY & TEST DISTANCE: VERTICAL AT 3 M								
NO.	FREQ. (MHz)	EMISSION LEVEL (dBuV/m)	LIMIT (dBuV/m)	MARGIN (dB)	ANTENNA HEIGHT (m)	TABLE ANGLE (Degree)	RAW VALUE (dBuV)	CORRECTION FACTOR (dB/m)
1	5150.00	44.8 PK	74.0	-29.2	1.00 V	327	6.60	38.20
2	5150.00	32.5 AV	54.0	-21.5	1.00 V	327	-5.70	38.20
3	*5260.00	99.7 PK			1.00 V	327	61.40	38.30
4	*5260.00	88.6 AV			1.00 V	327	50.30	38.30
5	#10520.00	56.0 PK	68.3	-12.3	1.43 V	328	7.70	48.30

**REMARKS:**

1. Emission level (dBuV/m) = Raw Value (dBuV) + Correction Factor (dB/m).
2. Correction Factor (dB/m) = Antenna Factor (dB/m) + Cable Factor (dB).
3. The other emission levels were very low against the limit.
4. Margin value = Emission level – Limit value.
5. “ \* “: Fundamental frequency.
6. “#”: The radiated frequency is out the restricted band.



A D T

EUT TEST CONDITION		MEASUREMENT DETAIL	
CHANNEL	Channel 60	FREQUENCY RANGE	1 ~ 40GHz
INPUT POWER	120Vac, 60 Hz	DETECTOR FUNCTION	Peak (PK) Average (AV)
ENVIRONMENTAL CONDITIONS	25deg. C, 68%RH	TESTED BY	Anderson Hong

ANTENNA POLARITY & TEST DISTANCE: HORIZONTAL AT 3 M								
NO.	FREQ. (MHz)	EMISSION LEVEL (dBuV/m)	LIMIT (dBuV/m)	MARGIN (dB)	ANTENNA HEIGHT (m)	TABLE ANGLE (Degree)	RAW VALUE (dBuV)	CORRECTION FACTOR (dB/m)
1	*5300.00	106.4 PK			1.08 H	11	68.00	38.40
2	*5300.00	95.4 AV			1.08 H	11	57.00	38.40
3	10600.00	56.7 PK	74.0	-17.3	1.38 H	323	8.40	48.30
4	10600.00	43.3 AV	54.0	-10.7	1.38 H	323	-5.00	48.30
5	15900.00	57.2 PK	74.0	-16.8	1.15 H	245	8.80	48.40
6	15900.00	43.6 AV	54.0	-10.4	1.15 H	245	-4.80	48.40
ANTENNA POLARITY & TEST DISTANCE: VERTICAL AT 3 M								
NO.	FREQ. (MHz)	EMISSION LEVEL (dBuV/m)	LIMIT (dBuV/m)	MARGIN (dB)	ANTENNA HEIGHT (m)	TABLE ANGLE (Degree)	RAW VALUE (dBuV)	CORRECTION FACTOR (dB/m)
1	*5300.00	99.4 PK			1.02 V	324	61.00	38.40
2	*5300.00	88.4 AV			1.02 V	324	50.00	38.40
3	10600.00	56.1 PK	74.0	-17.9	1.40 V	326	7.80	48.30
4	10600.00	42.6 AV	54.0	-11.4	1.40 V	326	-5.70	48.30
5	15900.00	56.8 PK	74.0	-17.2	1.18 V	240	8.40	48.40
6	15900.00	43.2 AV	54.0	-10.8	1.18 V	240	-5.20	48.40

**REMARKS:**

1. Emission level (dBuV/m) = Raw Value (dBuV) + Correction Factor (dB/m).
2. Correction Factor (dB/m) = Antenna Factor (dB/m) + Cable Factor (dB).
3. The other emission levels were very low against the limit.
4. Margin value = Emission level – Limit value.
5. “ \* ”: Fundamental frequency.



A D T

EUT TEST CONDITION		MEASUREMENT DETAIL	
CHANNEL	Channel 64	FREQUENCY RANGE	1 ~ 40GHz
INPUT POWER	120Vac, 60 Hz	DETECTOR FUNCTION	Peak (PK) Average (AV)
ENVIRONMENTAL CONDITIONS	25deg. C, 68%RH	TESTED BY	Anderson Hong

ANTENNA POLARITY & TEST DISTANCE: HORIZONTAL AT 3 M								
NO.	FREQ. (MHz)	EMISSION LEVEL (dBuV/m)	LIMIT (dBuV/m)	MARGIN (dB)	ANTENNA HEIGHT (m)	TABLE ANGLE (Degree)	RAW VALUE (dBuV)	CORRECTION FACTOR (dB/m)
1	*5320.00	108.3 PK			1.06 H	4	69.90	38.40
2	*5320.00	97.3 AV			1.06 H	4	58.90	38.40
3	5350.00	72.4 PK	74.0	-1.6	1.06 H	4	33.90	38.50
4	<b>5350.00</b>	<b>53.0 AV</b>	<b>54.0</b>	<b>-1.0</b>	<b>1.06 H</b>	<b>4</b>	<b>14.50</b>	<b>38.50</b>
5	10640.00	57.1 PK	74.0	-16.9	1.35 H	321	8.60	48.50
6	10640.00	43.7 AV	54.0	-10.3	1.35 H	321	-4.80	48.50
ANTENNA POLARITY & TEST DISTANCE: VERTICAL AT 3 M								
NO.	FREQ. (MHz)	EMISSION LEVEL (dBuV/m)	LIMIT (dBuV/m)	MARGIN (dB)	ANTENNA HEIGHT (m)	TABLE ANGLE (Degree)	RAW VALUE (dBuV)	CORRECTION FACTOR (dB/m)
1	*5320.00	99.4 PK			1.09 V	336	61.00	38.40
2	*5320.00	88.4 AV			1.09 V	336	50.00	38.40
3	5350.00	64.0 PK	74.0	-10.0	1.09 V	336	25.50	38.50
4	5350.00	45.4 AV	54.0	-8.6	1.09 V	336	6.90	38.50
5	10640.00	56.5 PK	74.0	-17.5	1.42 V	322	8.00	48.50
6	10640.00	43.0 AV	54.0	-11.0	1.42 V	322	-5.50	48.50

**REMARKS:**

1. Emission level (dBuV/m) = Raw Value (dBuV) + Correction Factor (dB/m).
2. Correction Factor (dB/m) = Antenna Factor (dB/m) + Cable Factor (dB).
3. The other emission levels were very low against the limit.
4. Margin value = Emission level – Limit value.
5. “ \* “: Fundamental frequency.





A D T

EUT TEST CONDITION		MEASUREMENT DETAIL	
CHANNEL	Channel 100	FREQUENCY RANGE	1 ~ 40GHz
INPUT POWER	120Vac, 60 Hz	DETECTOR FUNCTION	Peak (PK) Average (AV)
ENVIRONMENTAL CONDITIONS	25deg. C, 68%RH	TESTED BY	Anderson Hong

ANTENNA POLARITY & TEST DISTANCE: HORIZONTAL AT 3 M								
NO.	FREQ. (MHz)	EMISSION LEVEL (dBuV/m)	LIMIT (dBuV/m)	MARGIN (dB)	ANTENNA HEIGHT (m)	TABLE ANGLE (Degree)	RAW VALUE (dBuV)	CORRECTION FACTOR (dB/m)
1	5460.00	57.4 PK	74.0	-16.6	1.00 H	320	18.70	38.70
2	5460.00	41.8 AV	54.0	-12.2	1.00 H	320	3.10	38.70
3	#5470.00	67.3 PK	68.3	-1.0	1.00 H	320	28.60	38.70
4	*5500.00	106.7 PK			1.00 H	320	68.00	38.70
5	*5500.00	95.7 AV			1.00 H	320	57.00	38.70
6	11000.00	56.5 PK	74.0	-17.5	1.38 H	325	7.30	49.20
7	11000.00	43.1 AV	54.0	-10.9	1.38 H	325	-6.10	49.20
ANTENNA POLARITY & TEST DISTANCE: VERTICAL AT 3 M								
NO.	FREQ. (MHz)	EMISSION LEVEL (dBuV/m)	LIMIT (dBuV/m)	MARGIN (dB)	ANTENNA HEIGHT (m)	TABLE ANGLE (Degree)	RAW VALUE (dBuV)	CORRECTION FACTOR (dB/m)
1	5460.00	52.4 PK	74.0	-21.6	1.00 V	77	13.70	38.70
2	5460.00	36.3 AV	54.0	-17.7	1.00 V	77	-2.40	38.70
3	#5470.00	61.1 PK	68.3	-7.2	1.00 V	77	22.40	38.70
4	*5500.00	100.4 PK			1.00 V	77	61.70	38.70
5	*5500.00	89.5 AV			1.00 V	77	50.80	38.70
6	11000.00	56.0 PK	74.0	-18.0	1.45 V	326	6.80	49.20
7	11000.00	42.5 AV	54.0	-11.5	1.45 V	326	-6.70	49.20

**REMARKS:**

1. Emission level (dBuV/m) = Raw Value (dBuV) + Correction Factor (dB/m).
2. Correction Factor (dB/m) = Antenna Factor (dB/m) + Cable Factor (dB).
3. The other emission levels were very low against the limit.
4. Margin value = Emission level – Limit value.
5. “ \* “: Fundamental frequency.
6. “#”:The radiated frequency is out the restricted band.



A D T

EUT TEST CONDITION		MEASUREMENT DETAIL	
CHANNEL	Channel 116	FREQUENCY RANGE	1 ~ 40GHz
INPUT POWER	120Vac, 60 Hz	DETECTOR FUNCTION	Peak (PK) Average (AV)
ENVIRONMENTAL CONDITIONS	25deg. C, 68%RH	TESTED BY	Anderson Hong

ANTENNA POLARITY & TEST DISTANCE: HORIZONTAL AT 3 M								
NO.	FREQ. (MHz)	EMISSION LEVEL (dBuV/m)	LIMIT (dBuV/m)	MARGIN (dB)	ANTENNA HEIGHT (m)	TABLE ANGLE (Degree)	RAW VALUE (dBuV)	CORRECTION FACTOR (dB/m)
1	*5580.00	108.5 PK			1.00 H	320	69.60	38.90
2	*5580.00	97.5 AV			1.00 H	320	58.60	38.90
3	11160.00	57.5 PK	74.0	-16.5	1.31 H	322	8.20	49.30
4	11160.00	44.0 AV	54.0	-10.0	1.31 H	322	-5.30	49.30
5	#16740.00	60.6 PK	68.3	-7.7	1.45 H	98	9.10	51.50
ANTENNA POLARITY & TEST DISTANCE: VERTICAL AT 3 M								
NO.	FREQ. (MHz)	EMISSION LEVEL (dBuV/m)	LIMIT (dBuV/m)	MARGIN (dB)	ANTENNA HEIGHT (m)	TABLE ANGLE (Degree)	RAW VALUE (dBuV)	CORRECTION FACTOR (dB/m)
1	*5580.00	102.7 PK			1.00 V	82	63.80	38.90
2	*5580.00	91.7 AV			1.00 V	82	52.80	38.90
3	11160.00	57.3 PK	74.0	-16.7	1.50 V	317	8.00	49.30
4	11160.00	43.8 AV	54.0	-10.2	1.50 V	317	-5.50	49.30
5	#16740.00	60.0 PK	68.3	-8.3	1.20 V	329	8.50	51.50

**REMARKS:**

1. Emission level (dBuV/m) = Raw Value (dBuV) + Correction Factor (dB/m).
2. Correction Factor (dB/m) = Antenna Factor (dB/m) + Cable Factor (dB).
3. The other emission levels were very low against the limit.
4. Margin value = Emission level – Limit value.
5. “ \* “: Fundamental frequency.
6. “#”:The radiated frequency is out the restricted band.



A D T

EUT TEST CONDITION		MEASUREMENT DETAIL	
CHANNEL	Channel 140	FREQUENCY RANGE	1 ~ 40GHz
INPUT POWER	120Vac, 60 Hz	DETECTOR FUNCTION	Peak (PK) Average (AV)
ENVIRONMENTAL CONDITIONS	25deg. C, 68%RH	TESTED BY	Anderson Hong

ANTENNA POLARITY & TEST DISTANCE: HORIZONTAL AT 3 M								
NO.	FREQ. (MHz)	EMISSION LEVEL (dBuV/m)	LIMIT (dBuV/m)	MARGIN (dB)	ANTENNA HEIGHT (m)	TABLE ANGLE (Degree)	RAW VALUE (dBuV)	CORRECTION FACTOR (dB/m)
1	*5700.00	105.9 PK			1.00 H	323	66.70	39.20
2	*5700.00	94.9 AV			1.00 H	323	55.70	39.20
3	#5725.00	67.0 PK	68.3	-1.3	1.00 H	323	27.80	39.20
4	11400.00	56.7 PK	74.0	-17.3	1.40 H	325	7.40	49.30
5	11400.00	43.3 AV	54.0	-10.7	1.40 H	325	-6.00	49.30
ANTENNA POLARITY & TEST DISTANCE: VERTICAL AT 3 M								
NO.	FREQ. (MHz)	EMISSION LEVEL (dBuV/m)	LIMIT (dBuV/m)	MARGIN (dB)	ANTENNA HEIGHT (m)	TABLE ANGLE (Degree)	RAW VALUE (dBuV)	CORRECTION FACTOR (dB/m)
1	*5700.00	97.8 PK			1.00 V	33	58.60	39.20
2	*5700.00	86.8 AV			1.00 V	33	47.60	39.20
3	#5725.00	59.4 PK	68.3	-8.9	1.00 V	33	20.20	39.20
4	11400.00	56.5 PK	74.0	-17.5	1.43 V	322	7.20	49.30
5	11400.00	43.0 AV	54.0	-11.0	1.43 V	322	-6.30	49.30

**REMARKS:**

1. Emission level (dBuV/m) = Raw Value (dBuV) + Correction Factor (dB/m).
2. Correction Factor (dB/m) = Antenna Factor (dB/m) + Cable Factor (dB).
3. The other emission levels were very low against the limit.
4. Margin value = Emission level – Limit value.
5. “ \* “: Fundamental frequency.
6. “#”:The radiated frequency is out the restricted band.



## 802.11n (20MHz)

EUT TEST CONDITION		MEASUREMENT DETAIL	
CHANNEL	Channel 36	FREQUENCY RANGE	1 ~ 40GHz
INPUT POWER	120Vac, 60 Hz	DETECTOR FUNCTION	Peak (PK) Average (AV)
ENVIRONMENTAL CONDITIONS	25deg. C, 68%RH	TESTED BY	Anderson Hong

ANTENNA POLARITY & TEST DISTANCE: HORIZONTAL AT 3 M								
NO.	FREQ. (MHz)	EMISSION LEVEL (dBuV/m)	LIMIT (dBuV/m)	MARGIN (dB)	ANTENNA HEIGHT (m)	TABLE ANGLE (Degree)	RAW VALUE (dBuV)	CORRECTION FACTOR (dB/m)
1	5150.00	60.8 PK	74.0	-13.2	1.10 H	1	22.60	38.20
2	5150.00	44.5 AV	54.0	-9.5	1.10 H	1	6.30	38.20
3	*5180.00	100.4 PK			1.10 H	1	62.20	38.20
4	*5180.00	89.4 AV			1.10 H	1	51.20	38.20
5	#10360.00	53.0 PK	68.3	-15.3	1.00 H	85	5.00	48.00

ANTENNA POLARITY & TEST DISTANCE: VERTICAL AT 3 M								
NO.	FREQ. (MHz)	EMISSION LEVEL (dBuV/m)	LIMIT (dBuV/m)	MARGIN (dB)	ANTENNA HEIGHT (m)	TABLE ANGLE (Degree)	RAW VALUE (dBuV)	CORRECTION FACTOR (dB/m)
1	5150.00	56.3 PK	74.0	-17.7	1.00 V	326	18.10	38.20
2	5150.00	40.7 AV	54.0	-13.3	1.00 V	326	2.50	38.20
3	*5180.00	94.9 PK			1.00 V	326	56.70	38.20
4	*5180.00	83.9 AV			1.00 V	326	45.70	38.20
5	#10360.00	52.9 PK	68.3	-15.4	1.40 V	320	4.90	48.00

**REMARKS:**

1. Emission level (dBuV/m) = Raw Value (dBuV) + Correction Factor (dB/m).
2. Correction Factor (dB/m) = Antenna Factor (dB/m) + Cable Factor (dB).
3. The other emission levels were very low against the limit.
4. Margin value = Emission level – Limit value.
5. “ \* “: Fundamental frequency.
6. “#”: The radiated frequency is out the restricted band.



A D T

EUT TEST CONDITION		MEASUREMENT DETAIL	
CHANNEL	Channel 40	FREQUENCY RANGE	1 ~ 40GHz
INPUT POWER	120Vac, 60 Hz	DETECTOR FUNCTION	Peak (PK) Average (AV)
ENVIRONMENTAL CONDITIONS	25deg. C, 68%RH	TESTED BY	Anderson Hong

ANTENNA POLARITY & TEST DISTANCE: HORIZONTAL AT 3 M								
NO.	FREQ. (MHz)	EMISSION LEVEL (dBuV/m)	LIMIT (dBuV/m)	MARGIN (dB)	ANTENNA HEIGHT (m)	TABLE ANGLE (Degree)	RAW VALUE (dBuV)	CORRECTION FACTOR (dB/m)
1	*5200.00	100.7 PK			1.11 H	5	62.50	38.20
2	*5200.00	89.7 AV			1.11 H	5	51.50	38.20
3	#10400.00	52.7 PK	68.3	-15.6	1.00 H	81	4.60	48.10
4	15600.00	55.9 PK	74.0	-18.1	1.15 H	115	6.80	49.10
5	15600.00	43.0 AV	54.0	-11.0	1.15 H	115	-6.10	49.10
ANTENNA POLARITY & TEST DISTANCE: VERTICAL AT 3 M								
NO.	FREQ. (MHz)	EMISSION LEVEL (dBuV/m)	LIMIT (dBuV/m)	MARGIN (dB)	ANTENNA HEIGHT (m)	TABLE ANGLE (Degree)	RAW VALUE (dBuV)	CORRECTION FACTOR (dB/m)
1	*5200.00	95.2 PK			1.00 V	330	57.00	38.20
2	*5200.00	84.1 AV			1.00 V	330	45.90	38.20
3	#10400.00	53.0 PK	68.3	-15.3	1.42 V	321	4.90	48.10
4	15600.00	56.9 PK	74.0	-17.1	1.32 V	286	7.80	49.10
5	15600.00	43.2 AV	54.0	-10.8	1.32 V	286	-5.90	49.10

**REMARKS:**

1. Emission level (dBuV/m) = Raw Value (dBuV) + Correction Factor (dB/m).
2. Correction Factor (dB/m) = Antenna Factor (dB/m) + Cable Factor (dB).
3. The other emission levels were very low against the limit.
4. Margin value = Emission level – Limit value.
5. “ \* “: Fundamental frequency.
6. “#”:The radiated frequency is out the restricted band.



A D T

EUT TEST CONDITION		MEASUREMENT DETAIL	
CHANNEL	Channel 48	FREQUENCY RANGE	1 ~ 40GHz
INPUT POWER	120Vac, 60 Hz	DETECTOR FUNCTION	Peak (PK) Average (AV)
ENVIRONMENTAL CONDITIONS	25deg. C, 68%RH	TESTED BY	Anderson Hong

ANTENNA POLARITY & TEST DISTANCE: HORIZONTAL AT 3 M								
NO.	FREQ. (MHz)	EMISSION LEVEL (dBuV/m)	LIMIT (dBuV/m)	MARGIN (dB)	ANTENNA HEIGHT (m)	TABLE ANGLE (Degree)	RAW VALUE (dBuV)	CORRECTION FACTOR (dB/m)
1	*5240.00	102.1 PK			1.04 H	327	63.80	38.30
2	*5240.00	91.2 AV			1.04 H	327	52.90	38.30
3	5350.00	45.0 PK	74.0	-29.0	1.04 H	327	6.50	38.50
4	5350.00	31.7 AV	54.0	-22.3	1.04 H	327	-6.80	38.50
5	#10480.00	53.9 PK	68.3	-14.4	1.00 H	81	5.70	48.20
ANTENNA POLARITY & TEST DISTANCE: VERTICAL AT 3 M								
NO.	FREQ. (MHz)	EMISSION LEVEL (dBuV/m)	LIMIT (dBuV/m)	MARGIN (dB)	ANTENNA HEIGHT (m)	TABLE ANGLE (Degree)	RAW VALUE (dBuV)	CORRECTION FACTOR (dB/m)
1	*5240.00	95.8 PK			1.00 V	327	57.50	38.30
2	*5240.00	84.7 AV			1.00 V	327	46.40	38.30
3	5350.00	42.2 PK	74.0	-31.8	1.00 V	327	3.70	38.50
4	5350.00	29.7 AV	54.0	-24.3	1.00 V	327	-8.80	38.50
5	#10480.00	53.8 PK	68.3	-14.5	1.41 V	320	5.60	48.20

**REMARKS:**

1. Emission level (dBuV/m) = Raw Value (dBuV) + Correction Factor (dB/m).
2. Correction Factor (dB/m) = Antenna Factor (dB/m) + Cable Factor (dB).
3. The other emission levels were very low against the limit.
4. Margin value = Emission level – Limit value.
5. “ \* “: Fundamental frequency.
6. “#”:The radiated frequency is out the restricted band.



A D T

EUT TEST CONDITION		MEASUREMENT DETAIL	
CHANNEL	Channel 52	FREQUENCY RANGE	1 ~ 40GHz
INPUT POWER	120Vac, 60 Hz	DETECTOR FUNCTION	Peak (PK) Average (AV)
ENVIRONMENTAL CONDITIONS	25deg. C, 68%RH	TESTED BY	Anderson Hong

ANTENNA POLARITY & TEST DISTANCE: HORIZONTAL AT 3 M								
NO.	FREQ. (MHz)	EMISSION LEVEL (dBuV/m)	LIMIT (dBuV/m)	MARGIN (dB)	ANTENNA HEIGHT (m)	TABLE ANGLE (Degree)	RAW VALUE (dBuV)	CORRECTION FACTOR (dB/m)
1	5150.00	45.9 PK	74.0	-28.1	1.05 H	325	7.70	38.20
2	5150.00	33.6 AV	54.0	-20.4	1.05 H	325	-4.60	38.20
3	*5260.00	106.1 PK			1.05 H	325	67.80	38.30
4	*5260.00	95.1 AV			1.05 H	325	56.80	38.30
5	#10520.00	55.8 PK	68.3	-12.5	1.00 H	88	7.50	48.30
ANTENNA POLARITY & TEST DISTANCE: VERTICAL AT 3 M								
NO.	FREQ. (MHz)	EMISSION LEVEL (dBuV/m)	LIMIT (dBuV/m)	MARGIN (dB)	ANTENNA HEIGHT (m)	TABLE ANGLE (Degree)	RAW VALUE (dBuV)	CORRECTION FACTOR (dB/m)
1	5150.00	44.4 PK	74.0	-29.6	1.10 V	322	6.20	38.20
2	5150.00	32.1 AV	54.0	-21.9	1.10 V	322	-6.10	38.20
3	*5260.00	98.4 PK			1.10 V	322	60.10	38.30
4	*5260.00	87.4 AV			1.10 V	322	49.10	38.30
5	#10520.00	55.7 PK	68.3	-12.6	1.44 V	325	7.40	48.30

**REMARKS:**

1. Emission level (dBuV/m) = Raw Value (dBuV) + Correction Factor (dB/m).
2. Correction Factor (dB/m) = Antenna Factor (dB/m) + Cable Factor (dB).
3. The other emission levels were very low against the limit.
4. Margin value = Emission level – Limit value.
5. “ \* “: Fundamental frequency.
6. “#”:The radiated frequency is out the restricted band.



A D T

EUT TEST CONDITION		MEASUREMENT DETAIL	
CHANNEL	Channel 60	FREQUENCY RANGE	1 ~ 40GHz
INPUT POWER	120Vac, 60 Hz	DETECTOR FUNCTION	Peak (PK) Average (AV)
ENVIRONMENTAL CONDITIONS	25deg. C, 68%RH	TESTED BY	Anderson Hong

ANTENNA POLARITY & TEST DISTANCE: HORIZONTAL AT 3 M								
NO.	FREQ. (MHz)	EMISSION LEVEL (dBuV/m)	LIMIT (dBuV/m)	MARGIN (dB)	ANTENNA HEIGHT (m)	TABLE ANGLE (Degree)	RAW VALUE (dBuV)	CORRECTION FACTOR (dB/m)
1	*5300.00	106.4 PK			1.03 H	328	68.00	38.40
2	*5300.00	95.3 AV			1.03 H	328	56.90	38.40
3	10600.00	56.4 PK	74.0	-17.6	1.35 H	321	8.10	48.30
4	10600.00	43.1 AV	54.0	-10.9	1.35 H	321	-5.20	48.30
5	15900.00	57.0 PK	74.0	-17.0	1.13 H	241	8.60	48.40
6	15900.00	43.4 AV	54.0	-10.6	1.13 H	241	-5.00	48.40
ANTENNA POLARITY & TEST DISTANCE: VERTICAL AT 3 M								
NO.	FREQ. (MHz)	EMISSION LEVEL (dBuV/m)	LIMIT (dBuV/m)	MARGIN (dB)	ANTENNA HEIGHT (m)	TABLE ANGLE (Degree)	RAW VALUE (dBuV)	CORRECTION FACTOR (dB/m)
1	*5300.00	98.8 PK			1.08 V	321	60.40	38.40
2	*5300.00	87.8 AV			1.08 V	321	49.40	38.40
3	10600.00	55.7 PK	74.0	-18.3	1.43 V	330	7.40	48.30
4	10600.00	42.3 AV	54.0	-11.7	1.43 V	330	-6.00	48.30
5	15900.00	56.5 PK	74.0	-17.5	1.15 V	241	8.10	48.40
6	15900.00	43.0 AV	54.0	-11.0	1.15 V	241	-5.40	48.40

**REMARKS:**

1. Emission level (dBuV/m) = Raw Value (dBuV) + Correction Factor (dB/m).
2. Correction Factor (dB/m) = Antenna Factor (dB/m) + Cable Factor (dB).
3. The other emission levels were very low against the limit.
4. Margin value = Emission level – Limit value.
5. “ \* ”: Fundamental frequency.





A D T

EUT TEST CONDITION		MEASUREMENT DETAIL	
CHANNEL	Channel 64	FREQUENCY RANGE	1 ~ 40GHz
INPUT POWER	120Vac, 60 Hz	DETECTOR FUNCTION	Peak (PK) Average (AV)
ENVIRONMENTAL CONDITIONS	25deg. C, 68%RH	TESTED BY	Anderson Hong

ANTENNA POLARITY & TEST DISTANCE: HORIZONTAL AT 3 M								
NO.	FREQ. (MHz)	EMISSION LEVEL (dBuV/m)	LIMIT (dBuV/m)	MARGIN (dB)	ANTENNA HEIGHT (m)	TABLE ANGLE (Degree)	RAW VALUE (dBuV)	CORRECTION FACTOR (dB/m)
1	*5320.00	107.1 PK			1.03 H	323	68.70	38.40
2	*5320.00	96.0 AV			1.03 H	323	57.60	38.40
3	5350.00	71.7 PK	74.0	-2.3	1.03 H	323	33.20	38.50
4	5350.00	52.2 AV	54.0	-1.8	1.03 H	323	13.70	38.50
5	10640.00	56.8 PK	74.0	-17.2	1.30 H	326	8.30	48.50
6	10640.00	43.5 AV	54.0	-10.5	1.30 H	326	-5.00	48.50
ANTENNA POLARITY & TEST DISTANCE: VERTICAL AT 3 M								
NO.	FREQ. (MHz)	EMISSION LEVEL (dBuV/m)	LIMIT (dBuV/m)	MARGIN (dB)	ANTENNA HEIGHT (m)	TABLE ANGLE (Degree)	RAW VALUE (dBuV)	CORRECTION FACTOR (dB/m)
1	*5320.00	99.0 PK			1.08 V	319	60.60	38.40
2	*5320.00	88.0 AV			1.08 V	319	49.60	38.40
3	5350.00	64.2 PK	74.0	-9.8	1.08 V	319	25.70	38.50
4	5350.00	45.0 AV	54.0	-9.0	1.08 V	319	6.50	38.50
5	10640.00	56.1 PK	74.0	-17.9	1.40 V	325	7.60	48.50
6	10640.00	42.7 AV	54.0	-11.3	1.40 V	325	-5.80	48.50

**REMARKS:**

1. Emission level (dBuV/m) = Raw Value (dBuV) + Correction Factor (dB/m).
2. Correction Factor (dB/m) = Antenna Factor (dB/m) + Cable Factor (dB).
3. The other emission levels were very low against the limit.
4. Margin value = Emission level – Limit value.
5. “ \* “: Fundamental frequency.



A D T

EUT TEST CONDITION		MEASUREMENT DETAIL	
CHANNEL	Channel 100	FREQUENCY RANGE	1 ~ 40GHz
INPUT POWER	120Vac, 60 Hz	DETECTOR FUNCTION	Peak (PK) Average (AV)
ENVIRONMENTAL CONDITIONS	25deg. C, 68%RH	TESTED BY	Anderson Hong

ANTENNA POLARITY & TEST DISTANCE: HORIZONTAL AT 3 M								
NO.	FREQ. (MHz)	EMISSION LEVEL (dBuV/m)	LIMIT (dBuV/m)	MARGIN (dB)	ANTENNA HEIGHT (m)	TABLE ANGLE (Degree)	RAW VALUE (dBuV)	CORRECTION FACTOR (dB/m)
1	5460.00	58.2 PK	74.0	-15.8	1.00 H	318	19.50	38.70
2	5460.00	42.3 AV	54.0	-11.7	1.00 H	318	3.60	38.70
3	#5470.00	67.2 PK	68.3	-1.1	1.00 H	318	28.50	38.70
4	*5500.00	105.3 PK			1.00 H	318	66.60	38.70
5	*5500.00	94.4 AV			1.00 H	318	55.70	38.70
6	11000.00	56.0 PK	74.0	-18.0	1.35 H	321	6.80	49.20
7	11000.00	42.7 AV	54.0	-11.3	1.35 H	321	-6.50	49.20
ANTENNA POLARITY & TEST DISTANCE: VERTICAL AT 3 M								
NO.	FREQ. (MHz)	EMISSION LEVEL (dBuV/m)	LIMIT (dBuV/m)	MARGIN (dB)	ANTENNA HEIGHT (m)	TABLE ANGLE (Degree)	RAW VALUE (dBuV)	CORRECTION FACTOR (dB/m)
1	5460.00	53.0 PK	74.0	-21.0	1.00 V	74	14.30	38.70
2	5460.00	37.4 AV	54.0	-16.6	1.00 V	74	-1.30	38.70
3	#5470.00	61.1 PK	68.3	-7.2	1.00 V	74	22.40	38.70
4	*5500.00	100.0 PK			1.00 V	74	61.30	38.70
5	*5500.00	89.0 AV			1.00 V	74	50.30	38.70
6	11000.00	55.7 PK	74.0	-18.3	1.43 V	323	6.50	49.20
7	11000.00	42.2 AV	54.0	-11.8	1.43 V	323	-7.00	49.20

**REMARKS:**

1. Emission level (dBuV/m) = Raw Value (dBuV) + Correction Factor (dB/m).
2. Correction Factor (dB/m) = Antenna Factor (dB/m) + Cable Factor (dB).
3. The other emission levels were very low against the limit.
4. Margin value = Emission level – Limit value.
5. “ \* “: Fundamental frequency.
6. “#”:The radiated frequency is out the restricted band.



A D T

EUT TEST CONDITION		MEASUREMENT DETAIL	
CHANNEL	Channel 116	FREQUENCY RANGE	1 ~ 40GHz
INPUT POWER	120Vac, 60 Hz	DETECTOR FUNCTION	Peak (PK) Average (AV)
ENVIRONMENTAL CONDITIONS	25deg. C, 68%RH	TESTED BY	Anderson Hong

ANTENNA POLARITY & TEST DISTANCE: HORIZONTAL AT 3 M								
NO.	FREQ. (MHz)	EMISSION LEVEL (dBuV/m)	LIMIT (dBuV/m)	MARGIN (dB)	ANTENNA HEIGHT (m)	TABLE ANGLE (Degree)	RAW VALUE (dBuV)	CORRECTION FACTOR (dB/m)
1	*5580.00	107.4 PK			1.00 H	321	68.50	38.90
2	*5580.00	96.3 AV			1.00 H	321	57.40	38.90
3	11160.00	57.3 PK	74.0	-16.7	1.36 H	326	8.00	49.30
4	11160.00	43.7 AV	54.0	-10.3	1.36 H	326	-5.60	49.30
5	#16740.00	60.5 PK	68.3	-7.8	1.43 H	99	9.00	51.50
ANTENNA POLARITY & TEST DISTANCE: VERTICAL AT 3 M								
NO.	FREQ. (MHz)	EMISSION LEVEL (dBuV/m)	LIMIT (dBuV/m)	MARGIN (dB)	ANTENNA HEIGHT (m)	TABLE ANGLE (Degree)	RAW VALUE (dBuV)	CORRECTION FACTOR (dB/m)
1	*5580.00	102.4 PK			1.00 V	73	63.50	38.90
2	*5580.00	91.4 AV			1.00 V	73	52.50	38.90
3	11160.00	57.2 PK	74.0	-16.8	1.48 V	327	7.90	49.30
4	11160.00	43.5 AV	54.0	-10.5	1.48 V	327	-5.80	49.30
5	#16740.00	60.6 PK	68.3	-7.7	1.42 V	94	9.10	51.50

**REMARKS:**

1. Emission level (dBuV/m) = Raw Value (dBuV) + Correction Factor (dB/m).
2. Correction Factor (dB/m) = Antenna Factor (dB/m) + Cable Factor (dB).
3. The other emission levels were very low against the limit.
4. Margin value = Emission level – Limit value.
5. “ \* “: Fundamental frequency.
6. “#”:The radiated frequency is out the restricted band.



A D T

EUT TEST CONDITION		MEASUREMENT DETAIL	
CHANNEL	Channel 140	FREQUENCY RANGE	1 ~ 40GHz
INPUT POWER	120Vac, 60 Hz	DETECTOR FUNCTION	Peak (PK) Average (AV)
ENVIRONMENTAL CONDITIONS	25deg. C, 68%RH	TESTED BY	Anderson Hong

ANTENNA POLARITY & TEST DISTANCE: HORIZONTAL AT 3 M								
NO.	FREQ. (MHz)	EMISSION LEVEL (dBuV/m)	LIMIT (dBuV/m)	MARGIN (dB)	ANTENNA HEIGHT (m)	TABLE ANGLE (Degree)	RAW VALUE (dBuV)	CORRECTION FACTOR (dB/m)
1	*5700.00	105.3 PK			1.00 H	320	66.10	39.20
2	*5700.00	94.3 AV			1.00 H	320	55.10	39.20
3	#5725.00	67.3 PK	68.3	-1.0	1.00 H	320	28.10	39.20
4	11400.00	56.4 PK	74.0	-17.6	1.42 H	328	7.10	49.30
5	11400.00	43.1 AV	54.0	-10.9	1.42 H	328	-6.20	49.30
ANTENNA POLARITY & TEST DISTANCE: VERTICAL AT 3 M								
NO.	FREQ. (MHz)	EMISSION LEVEL (dBuV/m)	LIMIT (dBuV/m)	MARGIN (dB)	ANTENNA HEIGHT (m)	TABLE ANGLE (Degree)	RAW VALUE (dBuV)	CORRECTION FACTOR (dB/m)
1	*5700.00	97.4 PK			1.02 V	25	58.20	39.20
2	*5700.00	86.4 AV			1.02 V	25	47.20	39.20
3	#5725.00	59.6 PK	68.3	-8.7	1.02 V	25	20.40	39.20
4	11400.00	56.2 PK	74.0	-17.8	1.40 V	320	6.90	49.30
5	11400.00	42.8 AV	54.0	-11.2	1.40 V	320	-6.50	49.30

**REMARKS:**

1. Emission level (dBuV/m) = Raw Value (dBuV) + Correction Factor (dB/m).
2. Correction Factor (dB/m) = Antenna Factor (dB/m) + Cable Factor (dB).
3. The other emission levels were very low against the limit.
4. Margin value = Emission level – Limit value.
5. “ \* “: Fundamental frequency.
6. “#”:The radiated frequency is out the restricted band.

## Test Mode B1 (Without MSR & Main Ant.)

802.11a

EUT TEST CONDITION		MEASUREMENT DETAIL	
CHANNEL	Channel 36	FREQUENCY RANGE	1 ~ 40GHz
INPUT POWER	120Vac, 60 Hz	DETECTOR FUNCTION	Peak (PK) Average (AV)
ENVIRONMENTAL CONDITIONS	25deg. C, 68%RH	TESTED BY	Anderson Hong

ANTENNA POLARITY & TEST DISTANCE: HORIZONTAL AT 3 M								
NO.	FREQ. (MHz)	EMISSION LEVEL (dBuV/m)	LIMIT (dBuV/m)	MARGIN (dB)	ANTENNA HEIGHT (m)	TABLE ANGLE (Degree)	RAW VALUE (dBuV)	CORRECTION FACTOR (dB/m)
1	5150.00	60.7 PK	74.0	-13.3	1.15 H	126	22.50	38.20
2	5150.00	43.5 AV	54.0	-10.5	1.15 H	126	5.30	38.20
3	*5180.00	98.9 PK			1.15 H	126	60.70	38.20
4	*5180.00	87.9 AV			1.15 H	126	49.70	38.20
5	#10360.00	53.1 PK	68.3	-15.2	1.00 H	83	5.10	48.00
ANTENNA POLARITY & TEST DISTANCE: VERTICAL AT 3 M								
NO.	FREQ. (MHz)	EMISSION LEVEL (dBuV/m)	LIMIT (dBuV/m)	MARGIN (dB)	ANTENNA HEIGHT (m)	TABLE ANGLE (Degree)	RAW VALUE (dBuV)	CORRECTION FACTOR (dB/m)
1	5150.00	59.3 PK	74.0	-14.7	1.00 V	225	21.10	38.20
2	5150.00	42.9 AV	54.0	-11.1	1.00 V	225	4.70	38.20
3	*5180.00	96.6 PK			1.00 V	225	58.40	38.20
4	*5180.00	85.5 AV			1.00 V	225	47.30	38.20
5	#10360.00	53.8 PK	68.3	-14.5	1.20 V	322	5.80	48.00

### REMARKS:

1. Emission level (dBuV/m) = Raw Value (dBuV) + Correction Factor (dB/m).
2. Correction Factor (dB/m) = Antenna Factor (dB/m) + Cable Factor (dB).
3. The other emission levels were very low against the limit.
4. Margin value = Emission level – Limit value.
5. " \* ": Fundamental frequency.
6. "#": The radiated frequency is out the restricted band.



A D T

EUT TEST CONDITION		MEASUREMENT DETAIL	
CHANNEL	Channel 40	FREQUENCY RANGE	1 ~ 40GHz
INPUT POWER	120Vac, 60 Hz	DETECTOR FUNCTION	Peak (PK) Average (AV)
ENVIRONMENTAL CONDITIONS	25deg. C, 68%RH	TESTED BY	Anderson Hong

ANTENNA POLARITY & TEST DISTANCE: HORIZONTAL AT 3 M								
NO.	FREQ. (MHz)	EMISSION LEVEL (dBuV/m)	LIMIT (dBuV/m)	MARGIN (dB)	ANTENNA HEIGHT (m)	TABLE ANGLE (Degree)	RAW VALUE (dBuV)	CORRECTION FACTOR (dB/m)
1	*5200.00	100.0 PK			1.12 H	124	61.80	38.20
2	*5200.00	89.0 AV			1.12 H	124	50.80	38.20
3	#10400.00	53.4 PK	68.3	-14.9	1.00 H	80	5.30	48.10
4	15600.00	55.9 PK	74.0	-18.1	1.28 H	231	6.80	49.10
5	15600.00	43.5 AV	54.0	-10.5	1.28 H	231	-5.60	49.10
ANTENNA POLARITY & TEST DISTANCE: VERTICAL AT 3 M								
NO.	FREQ. (MHz)	EMISSION LEVEL (dBuV/m)	LIMIT (dBuV/m)	MARGIN (dB)	ANTENNA HEIGHT (m)	TABLE ANGLE (Degree)	RAW VALUE (dBuV)	CORRECTION FACTOR (dB/m)
1	*5200.00	99.3 PK			1.00 V	209	61.10	38.20
2	*5200.00	88.7 AV			1.00 V	209	50.50	38.20
3	#10400.00	54.2 PK	68.3	-14.1	1.23 V	321	6.10	48.10
4	15600.00	57.8 PK	74.0	-16.2	1.10 V	321	8.70	49.10
5	15600.00	44.4 AV	54.0	-9.6	1.10 V	321	-4.70	49.10

**REMARKS:**

1. Emission level (dBuV/m) = Raw Value (dBuV) + Correction Factor (dB/m).
2. Correction Factor (dB/m) = Antenna Factor (dB/m) + Cable Factor (dB).
3. The other emission levels were very low against the limit.
4. Margin value = Emission level – Limit value.
5. “ \* “: Fundamental frequency.
6. “#”:The radiated frequency is out the restricted band.



A D T

EUT TEST CONDITION		MEASUREMENT DETAIL	
CHANNEL	Channel 48	FREQUENCY RANGE	1 ~ 40GHz
INPUT POWER	120Vac, 60 Hz	DETECTOR FUNCTION	Peak (PK) Average (AV)
ENVIRONMENTAL CONDITIONS	25deg. C, 68%RH	TESTED BY	Anderson Hong

ANTENNA POLARITY & TEST DISTANCE: HORIZONTAL AT 3 M								
NO.	FREQ. (MHz)	EMISSION LEVEL (dBuV/m)	LIMIT (dBuV/m)	MARGIN (dB)	ANTENNA HEIGHT (m)	TABLE ANGLE (Degree)	RAW VALUE (dBuV)	CORRECTION FACTOR (dB/m)
1	*5240.00	100.3 PK			1.12 H	126	62.00	38.30
2	*5240.00	89.4 AV			1.12 H	126	51.10	38.30
3	5350.00	52.1 PK	74.0	-21.9	1.12 H	126	13.60	38.50
4	5350.00	39.5 AV	54.0	-14.5	1.12 H	126	1.00	38.50
5	#10480.00	53.7 PK	68.3	-14.6	1.00 H	82	5.50	48.20
ANTENNA POLARITY & TEST DISTANCE: VERTICAL AT 3 M								
NO.	FREQ. (MHz)	EMISSION LEVEL (dBuV/m)	LIMIT (dBuV/m)	MARGIN (dB)	ANTENNA HEIGHT (m)	TABLE ANGLE (Degree)	RAW VALUE (dBuV)	CORRECTION FACTOR (dB/m)
1	*5240.00	96.5 PK			1.00 V	213	58.20	38.30
2	*5240.00	85.4 AV			1.00 V	213	47.10	38.30
3	5350.00	51.6 PK	74.0	-22.4	1.00 V	213	13.10	38.50
4	5350.00	38.9 AV	54.0	-15.1	1.00 V	213	0.40	38.50
5	#10480.00	54.5 PK	68.3	-13.8	1.19 V	318	6.30	48.20

**REMARKS:**

1. Emission level (dBuV/m) = Raw Value (dBuV) + Correction Factor (dB/m).
2. Correction Factor (dB/m) = Antenna Factor (dB/m) + Cable Factor (dB).
3. The other emission levels were very low against the limit.
4. Margin value = Emission level – Limit value.
5. “ \* “: Fundamental frequency.
6. “#”:The radiated frequency is out the restricted band.



A D T

EUT TEST CONDITION		MEASUREMENT DETAIL	
CHANNEL	Channel 52	FREQUENCY RANGE	1 ~ 40GHz
INPUT POWER	120Vac, 60 Hz	DETECTOR FUNCTION	Peak (PK) Average (AV)
ENVIRONMENTAL CONDITIONS	25deg. C, 68%RH	TESTED BY	Anderson Hong

ANTENNA POLARITY & TEST DISTANCE: HORIZONTAL AT 3 M								
NO.	FREQ. (MHz)	EMISSION LEVEL (dBuV/m)	LIMIT (dBuV/m)	MARGIN (dB)	ANTENNA HEIGHT (m)	TABLE ANGLE (Degree)	RAW VALUE (dBuV)	CORRECTION FACTOR (dB/m)
1	5150.00	54.8 PK	74.0	-19.2	1.12 H	124	16.60	38.20
2	5150.00	42.3 AV	54.0	-11.7	1.12 H	124	4.10	38.20
3	*5260.00	104.7 PK			1.12 H	124	66.40	38.30
4	*5260.00	93.7 AV			1.12 H	124	55.40	38.30
5	#10520.00	56.0 PK	68.3	-12.3	1.00 H	85	7.70	48.30
ANTENNA POLARITY & TEST DISTANCE: VERTICAL AT 3 M								
NO.	FREQ. (MHz)	EMISSION LEVEL (dBuV/m)	LIMIT (dBuV/m)	MARGIN (dB)	ANTENNA HEIGHT (m)	TABLE ANGLE (Degree)	RAW VALUE (dBuV)	CORRECTION FACTOR (dB/m)
1	5150.00	54.0 PK	74.0	-20.0	1.00 V	213	15.80	38.20
2	5150.00	41.8 AV	54.0	-12.2	1.00 V	213	3.60	38.20
3	*5260.00	100.3 PK			1.00 V	213	62.00	38.30
4	*5260.00	89.3 AV			1.00 V	213	51.00	38.30
5	#10520.00	56.8 PK	68.3	-11.5	1.21 V	321	8.50	48.30

**REMARKS:**

1. Emission level (dBuV/m) = Raw Value (dBuV) + Correction Factor (dB/m).
2. Correction Factor (dB/m) = Antenna Factor (dB/m) + Cable Factor (dB).
3. The other emission levels were very low against the limit.
4. Margin value = Emission level – Limit value.
5. “ \* “: Fundamental frequency.
6. “#”:The radiated frequency is out the restricted band.





A D T

EUT TEST CONDITION		MEASUREMENT DETAIL	
CHANNEL	Channel 60	FREQUENCY RANGE	1 ~ 40GHz
INPUT POWER	120Vac, 60 Hz	DETECTOR FUNCTION	Peak (PK) Average (AV)
ENVIRONMENTAL CONDITIONS	25deg. C, 68%RH	TESTED BY	Anderson Hong

ANTENNA POLARITY & TEST DISTANCE: HORIZONTAL AT 3 M								
NO.	FREQ. (MHz)	EMISSION LEVEL (dBuV/m)	LIMIT (dBuV/m)	MARGIN (dB)	ANTENNA HEIGHT (m)	TABLE ANGLE (Degree)	RAW VALUE (dBuV)	CORRECTION FACTOR (dB/m)
1	*5300.00	105.2 PK			1.11 H	125	66.80	38.40
2	*5300.00	94.2 AV			1.11 H	125	55.80	38.40
3	10600.00	55.0 PK	74.0	-19.0	1.01 H	89	6.70	48.30
4	10600.00	42.2 AV	54.0	-11.8	1.01 H	89	-6.10	48.30
5	15900.00	58.6 PK	74.0	-15.4	1.35 H	46	10.20	48.40
6	15900.00	45.7 AV	54.0	-8.3	1.35 H	46	-2.70	48.40
ANTENNA POLARITY & TEST DISTANCE: VERTICAL AT 3 M								
NO.	FREQ. (MHz)	EMISSION LEVEL (dBuV/m)	LIMIT (dBuV/m)	MARGIN (dB)	ANTENNA HEIGHT (m)	TABLE ANGLE (Degree)	RAW VALUE (dBuV)	CORRECTION FACTOR (dB/m)
1	*5300.00	99.7 PK			1.00 V	208	61.30	38.40
2	*5300.00	88.8 AV			1.00 V	208	50.40	38.40
3	10600.00	54.8 PK	74.0	-19.2	1.23 V	325	6.50	48.30
4	10600.00	42.1 AV	54.0	-11.9	1.23 V	325	-6.20	48.30
5	15900.00	58.4 PK	74.0	-15.6	1.14 V	281	10.00	48.40
6	15900.00	45.7 AV	54.0	-8.3	1.14 V	281	-2.70	48.40

**REMARKS:**

1. Emission level (dBuV/m) = Raw Value (dBuV) + Correction Factor (dB/m).
2. Correction Factor (dB/m) = Antenna Factor (dB/m) + Cable Factor (dB).
3. The other emission levels were very low against the limit.
4. Margin value = Emission level – Limit value.
5. “ \* ”: Fundamental frequency.



A D T

EUT TEST CONDITION		MEASUREMENT DETAIL	
CHANNEL	Channel 64	FREQUENCY RANGE	1 ~ 40GHz
INPUT POWER	120Vac, 60 Hz	DETECTOR FUNCTION	Peak (PK) Average (AV)
ENVIRONMENTAL CONDITIONS	25deg. C, 68%RH	TESTED BY	Anderson Hong

ANTENNA POLARITY & TEST DISTANCE: HORIZONTAL AT 3 M								
NO.	FREQ. (MHz)	EMISSION LEVEL (dBuV/m)	LIMIT (dBuV/m)	MARGIN (dB)	ANTENNA HEIGHT (m)	TABLE ANGLE (Degree)	RAW VALUE (dBuV)	CORRECTION FACTOR (dB/m)
1	*5320.00	105.6 PK			1.13 H	128	67.20	38.40
2	*5320.00	94.5 AV			1.13 H	128	56.10	38.40
3	5350.00	68.4 PK	74.0	-5.6	1.13 H	128	29.90	38.50
4	5350.00	50.7 AV	54.0	-3.3	1.13 H	128	12.20	38.50
5	10640.00	55.4 PK	74.0	-18.6	1.00 H	83	6.90	48.50
6	10640.00	42.6 AV	54.0	-11.4	1.00 H	83	-5.90	48.50

ANTENNA POLARITY & TEST DISTANCE: VERTICAL AT 3 M								
NO.	FREQ. (MHz)	EMISSION LEVEL (dBuV/m)	LIMIT (dBuV/m)	MARGIN (dB)	ANTENNA HEIGHT (m)	TABLE ANGLE (Degree)	RAW VALUE (dBuV)	CORRECTION FACTOR (dB/m)
1	*5320.00	100.4 PK			1.09 V	152	62.00	38.40
2	*5320.00	89.3 AV			1.09 V	152	50.90	38.40
3	5350.00	62.2 PK	74.0	-11.8	1.09 V	152	23.70	38.50
4	5350.00	46.7 AV	54.0	-7.3	1.09 V	152	8.20	38.50
5	10640.00	55.1 PK	74.0	-18.9	1.24 V	321	6.60	48.50
6	10640.00	42.5 AV	54.0	-11.5	1.24 V	321	-6.00	48.50

**REMARKS:**

1. Emission level (dBuV/m) = Raw Value (dBuV) + Correction Factor (dB/m).
2. Correction Factor (dB/m) = Antenna Factor (dB/m) + Cable Factor (dB).
3. The other emission levels were very low against the limit.
4. Margin value = Emission level – Limit value.
5. “ \* ”: Fundamental frequency.



A D T

EUT TEST CONDITION		MEASUREMENT DETAIL	
CHANNEL	Channel 100	FREQUENCY RANGE	1 ~ 40GHz
INPUT POWER	120Vac, 60 Hz	DETECTOR FUNCTION	Peak (PK) Average (AV)
ENVIRONMENTAL CONDITIONS	25deg. C, 68%RH	TESTED BY	Anderson Hong

ANTENNA POLARITY & TEST DISTANCE: HORIZONTAL AT 3 M								
NO.	FREQ. (MHz)	EMISSION LEVEL (dBuV/m)	LIMIT (dBuV/m)	MARGIN (dB)	ANTENNA HEIGHT (m)	TABLE ANGLE (Degree)	RAW VALUE (dBuV)	CORRECTION FACTOR (dB/m)
1	5460.00	63.5 PK	74.0	-10.5	1.07 H	307	24.80	38.70
2	5460.00	45.8 AV	54.0	-8.2	1.07 H	307	7.10	38.70
3	#5470.00	67.3 PK	68.3	-1.0	1.07 H	307	28.60	38.70
4	*5500.00	107.3 PK			1.08 H	313	68.60	38.70
5	*5500.00	96.1 AV			1.08 H	313	57.40	38.70
6	11000.00	55.4 PK	74.0	-18.6	1.22 H	215	6.20	49.20
7	11000.00	44.6 AV	54.0	-9.4	1.22 H	215	-4.60	49.20
ANTENNA POLARITY & TEST DISTANCE: VERTICAL AT 3 M								
NO.	FREQ. (MHz)	EMISSION LEVEL (dBuV/m)	LIMIT (dBuV/m)	MARGIN (dB)	ANTENNA HEIGHT (m)	TABLE ANGLE (Degree)	RAW VALUE (dBuV)	CORRECTION FACTOR (dB/m)
1	5460.00	59.7 PK	74.0	-14.3	1.30 V	342	21.00	38.70
2	5460.00	42.8 AV	54.0	-11.2	1.30 V	342	4.10	38.70
3	#5470.00	59.5 PK	68.3	-8.8	1.30 V	342	20.80	38.70
4	*5500.00	100.9 PK			1.16 V	342	62.20	38.70
5	*5500.00	89.9 AV			1.16 V	342	51.20	38.70
6	11000.00	55.9 PK	74.0	-18.1	1.17 V	298	6.70	49.20
7	11000.00	45.4 AV	54.0	-8.6	1.17 V	298	-3.80	49.20

**REMARKS:**

1. Emission level (dBuV/m) = Raw Value (dBuV) + Correction Factor (dB/m).
2. Correction Factor (dB/m) = Antenna Factor (dB/m) + Cable Factor (dB).
3. The other emission levels were very low against the limit.
4. Margin value = Emission level – Limit value.
5. “ \* “: Fundamental frequency.
6. “#”:The radiated frequency is out the restricted band.



A D T

EUT TEST CONDITION		MEASUREMENT DETAIL	
CHANNEL	Channel 116	FREQUENCY RANGE	1 ~ 40GHz
INPUT POWER	120Vac, 60 Hz	DETECTOR FUNCTION	Peak (PK) Average (AV)
ENVIRONMENTAL CONDITIONS	25deg. C, 68%RH	TESTED BY	Anderson Hong

ANTENNA POLARITY & TEST DISTANCE: HORIZONTAL AT 3 M								
NO.	FREQ. (MHz)	EMISSION LEVEL (dBuV/m)	LIMIT (dBuV/m)	MARGIN (dB)	ANTENNA HEIGHT (m)	TABLE ANGLE (Degree)	RAW VALUE (dBuV)	CORRECTION FACTOR (dB/m)
1	*5580.00	109.5 PK			1.05 H	304	70.60	38.90
2	*5580.00	98.0 AV			1.05 H	304	59.10	38.90
3	11160.00	54.2 PK	74.0	-19.8	1.04 H	218	4.90	49.30
4	11160.00	43.5 AV	54.0	-10.5	1.04 H	218	-5.80	49.30
5	#16740.00	58.7 PK	68.3	-9.6	1.12 H	169	7.20	51.50
ANTENNA POLARITY & TEST DISTANCE: VERTICAL AT 3 M								
NO.	FREQ. (MHz)	EMISSION LEVEL (dBuV/m)	LIMIT (dBuV/m)	MARGIN (dB)	ANTENNA HEIGHT (m)	TABLE ANGLE (Degree)	RAW VALUE (dBuV)	CORRECTION FACTOR (dB/m)
1	*5580.00	102.7 PK			1.28 V	352	63.80	38.90
2	*5580.00	91.7 AV			1.28 V	352	52.80	38.90
3	11160.00	54.8 PK	74.0	-19.2	1.21 V	196	5.50	49.30
4	11160.00	44.2 AV	54.0	-9.8	1.21 V	196	-5.10	49.30
5	#16740.00	57.1 PK	68.3	-11.2	1.17 V	158	5.60	51.50

**REMARKS:**

1. Emission level (dBuV/m) = Raw Value (dBuV) + Correction Factor (dB/m).
2. Correction Factor (dB/m) = Antenna Factor (dB/m) + Cable Factor (dB).
3. The other emission levels were very low against the limit.
4. Margin value = Emission level – Limit value.
5. “ \* “: Fundamental frequency.
6. “#”:The radiated frequency is out the restricted band.



A D T

EUT TEST CONDITION		MEASUREMENT DETAIL	
CHANNEL	Channel 140	FREQUENCY RANGE	1 ~ 40GHz
INPUT POWER	120Vac, 60 Hz	DETECTOR FUNCTION	Peak (PK) Average (AV)
ENVIRONMENTAL CONDITIONS	25deg. C, 68%RH	TESTED BY	Anderson Hong

ANTENNA POLARITY & TEST DISTANCE: HORIZONTAL AT 3 M								
NO.	FREQ. (MHz)	EMISSION LEVEL (dBuV/m)	LIMIT (dBuV/m)	MARGIN (dB)	ANTENNA HEIGHT (m)	TABLE ANGLE (Degree)	RAW VALUE (dBuV)	CORRECTION FACTOR (dB/m)
1	*5700.00	106.8 PK			1.04 H	315	67.60	39.20
2	*5700.00	95.7 AV			1.04 H	315	56.50	39.20
3	#5725.00	66.4 PK	68.3	-1.9	1.04 H	315	27.20	39.20
4	11400.00	54.2 PK	74.0	-19.8	1.25 H	208	4.90	49.30
5	11400.00	43.1 AV	54.0	-10.9	1.25 H	208	-6.20	49.30
ANTENNA POLARITY & TEST DISTANCE: VERTICAL AT 3 M								
NO.	FREQ. (MHz)	EMISSION LEVEL (dBuV/m)	LIMIT (dBuV/m)	MARGIN (dB)	ANTENNA HEIGHT (m)	TABLE ANGLE (Degree)	RAW VALUE (dBuV)	CORRECTION FACTOR (dB/m)
1	*5700.00	101.6 PK			1.00 V	336	62.40	39.20
2	*5700.00	90.5 AV			1.00 V	336	51.30	39.20
3	#5725.00	59.8 PK	68.3	-8.5	1.00 V	336	20.60	39.20
4	11400.00	54.3 PK	74.0	-19.7	1.25 V	218	5.00	49.30
5	11400.00	43.3 AV	54.0	-10.7	1.25 V	218	-6.00	49.30

**REMARKS:**

1. Emission level (dBuV/m) = Raw Value (dBuV) + Correction Factor (dB/m).
2. Correction Factor (dB/m) = Antenna Factor (dB/m) + Cable Factor (dB).
3. The other emission levels were very low against the limit.
4. Margin value = Emission level – Limit value.
5. “ \* “: Fundamental frequency.
6. “#”:The radiated frequency is out the restricted band.



A D T

### 802.11n (20MHz)

EUT TEST CONDITION		MEASUREMENT DETAIL	
CHANNEL	Channel 36	FREQUENCY RANGE	1 ~ 40GHz
INPUT POWER	120Vac, 60 Hz	DETECTOR FUNCTION	Peak (PK) Average (AV)
ENVIRONMENTAL CONDITIONS	25deg. C, 68%RH	TESTED BY	Anderson Hong

ANTENNA POLARITY & TEST DISTANCE: HORIZONTAL AT 3 M								
NO.	FREQ. (MHz)	EMISSION LEVEL (dBuV/m)	LIMIT (dBuV/m)	MARGIN (dB)	ANTENNA HEIGHT (m)	TABLE ANGLE (Degree)	RAW VALUE (dBuV)	CORRECTION FACTOR (dB/m)
1	5150.00	57.2 PK	74.0	-16.8	1.14 H	126	19.00	38.20
2	5150.00	42.7 AV	54.0	-11.3	1.14 H	126	4.50	38.20
3	*5180.00	98.0 PK			1.14 H	126	59.80	38.20
4	*5180.00	87.0 AV			1.14 H	126	48.80	38.20
5	#10360.00	52.8 PK	68.3	-15.5	1.00 H	80	4.80	48.00

ANTENNA POLARITY & TEST DISTANCE: VERTICAL AT 3 M								
NO.	FREQ. (MHz)	EMISSION LEVEL (dBuV/m)	LIMIT (dBuV/m)	MARGIN (dB)	ANTENNA HEIGHT (m)	TABLE ANGLE (Degree)	RAW VALUE (dBuV)	CORRECTION FACTOR (dB/m)
1	5150.00	57.1 PK	74.0	-16.9	1.11 V	222	18.90	38.20
2	5150.00	42.3 AV	54.0	-11.7	1.11 V	222	4.10	38.20
3	*5180.00	95.8 PK			1.11 V	222	57.60	38.20
4	*5180.00	84.8 AV			1.11 V	222	46.60	38.20
5	#10360.00	53.5 PK	68.3	-14.8	1.23 V	324	5.50	48.00

#### REMARKS:

1. Emission level (dBuV/m) = Raw Value (dBuV) + Correction Factor (dB/m).
2. Correction Factor (dB/m) = Antenna Factor (dB/m) + Cable Factor (dB).
3. The other emission levels were very low against the limit.
4. Margin value = Emission level – Limit value.
5. " \* ": Fundamental frequency.
6. "#": The radiated frequency is out the restricted band.



A D T

EUT TEST CONDITION		MEASUREMENT DETAIL	
CHANNEL	Channel 40	FREQUENCY RANGE	1 ~ 40GHz
INPUT POWER	120Vac, 60 Hz	DETECTOR FUNCTION	Peak (PK) Average (AV)
ENVIRONMENTAL CONDITIONS	25deg. C, 68%RH	TESTED BY	Anderson Hong

ANTENNA POLARITY & TEST DISTANCE: HORIZONTAL AT 3 M								
NO.	FREQ. (MHz)	EMISSION LEVEL (dBuV/m)	LIMIT (dBuV/m)	MARGIN (dB)	ANTENNA HEIGHT (m)	TABLE ANGLE (Degree)	RAW VALUE (dBuV)	CORRECTION FACTOR (dB/m)
1	*5200.00	98.2 PK			1.14 H	125	60.00	38.20
2	*5200.00	87.2 AV			1.14 H	125	49.00	38.20
3	#10400.00	52.4 PK	68.3	-15.9	1.00 H	83	4.30	48.10
4	15600.00	55.5 PK	74.0	-18.5	1.25 H	235	6.40	49.10
5	15600.00	43.1 AV	54.0	-10.9	1.25 H	235	-6.00	49.10
ANTENNA POLARITY & TEST DISTANCE: VERTICAL AT 3 M								
NO.	FREQ. (MHz)	EMISSION LEVEL (dBuV/m)	LIMIT (dBuV/m)	MARGIN (dB)	ANTENNA HEIGHT (m)	TABLE ANGLE (Degree)	RAW VALUE (dBuV)	CORRECTION FACTOR (dB/m)
1	*5200.00	94.8 PK			1.11 V	225	56.60	38.20
2	*5200.00	83.8 AV			1.11 V	225	45.60	38.20
3	#10400.00	53.1 PK	68.3	-15.2	1.20 V	320	5.00	48.10
4	15600.00	57.4 PK	74.0	-16.6	1.13 V	325	8.30	49.10
5	15600.00	44.1 AV	54.0	-9.9	1.13 V	325	-5.00	49.10

**REMARKS:**

1. Emission level (dBuV/m) = Raw Value (dBuV) + Correction Factor (dB/m).
2. Correction Factor (dB/m) = Antenna Factor (dB/m) + Cable Factor (dB).
3. The other emission levels were very low against the limit.
4. Margin value = Emission level – Limit value.
5. “ \* “: Fundamental frequency.
6. “#”:The radiated frequency is out the restricted band.



A D T

EUT TEST CONDITION		MEASUREMENT DETAIL	
CHANNEL	Channel 48	FREQUENCY RANGE	1 ~ 40GHz
INPUT POWER	120Vac, 60 Hz	DETECTOR FUNCTION	Peak (PK) Average (AV)
ENVIRONMENTAL CONDITIONS	25deg. C, 68%RH	TESTED BY	Anderson Hong

ANTENNA POLARITY & TEST DISTANCE: HORIZONTAL AT 3 M								
NO.	FREQ. (MHz)	EMISSION LEVEL (dBuV/m)	LIMIT (dBuV/m)	MARGIN (dB)	ANTENNA HEIGHT (m)	TABLE ANGLE (Degree)	RAW VALUE (dBuV)	CORRECTION FACTOR (dB/m)
1	*5240.00	99.8 PK			1.13 H	127	61.50	38.30
2	*5240.00	88.7 AV			1.13 H	127	50.40	38.30
3	5350.00	52.8 PK	74.0	-21.2	1.13 H	127	14.30	38.50
4	5350.00	39.9 AV	54.0	-14.1	1.13 H	127	1.40	38.50
5	#10480.00	53.2 PK	68.3	-15.1	1.00 H	80	5.00	48.20

ANTENNA POLARITY & TEST DISTANCE: VERTICAL AT 3 M								
NO.	FREQ. (MHz)	EMISSION LEVEL (dBuV/m)	LIMIT (dBuV/m)	MARGIN (dB)	ANTENNA HEIGHT (m)	TABLE ANGLE (Degree)	RAW VALUE (dBuV)	CORRECTION FACTOR (dB/m)
1	*5240.00	95.8 PK			1.10 V	223	57.50	38.30
2	*5240.00	84.8 AV			1.10 V	223	46.50	38.30
3	5350.00	52.0 PK	74.0	-22.0	1.10 V	223	13.50	38.50
4	5350.00	39.2 AV	54.0	-14.8	1.10 V	223	0.70	38.50
5	#10480.00	53.3 PK	68.3	-15.0	1.26 V	320	5.10	48.20

**REMARKS:**

1. Emission level (dBuV/m) = Raw Value (dBuV) + Correction Factor (dB/m).
2. Correction Factor (dB/m) = Antenna Factor (dB/m) + Cable Factor (dB).
3. The other emission levels were very low against the limit.
4. Margin value = Emission level – Limit value.
5. “ \* “: Fundamental frequency.
6. “#”:The radiated frequency is out the restricted band.





A D T

EUT TEST CONDITION		MEASUREMENT DETAIL	
CHANNEL	Channel 52	FREQUENCY RANGE	1 ~ 40GHz
INPUT POWER	120Vac, 60 Hz	DETECTOR FUNCTION	Peak (PK) Average (AV)
ENVIRONMENTAL CONDITIONS	25deg. C, 68%RH	TESTED BY	Anderson Hong

ANTENNA POLARITY & TEST DISTANCE: HORIZONTAL AT 3 M								
NO.	FREQ. (MHz)	EMISSION LEVEL (dBuV/m)	LIMIT (dBuV/m)	MARGIN (dB)	ANTENNA HEIGHT (m)	TABLE ANGLE (Degree)	RAW VALUE (dBuV)	CORRECTION FACTOR (dB/m)
1	5150.00	54.5 PK	74.0	-19.5	1.13 H	129	16.30	38.20
2	5150.00	42.1 AV	54.0	-11.9	1.13 H	129	3.90	38.20
3	*5260.00	104.6 PK			1.13 H	129	66.30	38.30
4	*5260.00	93.5 AV			1.13 H	129	55.20	38.30
5	#10520.00	55.8 PK	68.3	-12.5	1.00 H	88	7.50	48.30
ANTENNA POLARITY & TEST DISTANCE: VERTICAL AT 3 M								
NO.	FREQ. (MHz)	EMISSION LEVEL (dBuV/m)	LIMIT (dBuV/m)	MARGIN (dB)	ANTENNA HEIGHT (m)	TABLE ANGLE (Degree)	RAW VALUE (dBuV)	CORRECTION FACTOR (dB/m)
1	5150.00	53.7 PK	74.0	-20.3	1.07 V	135	15.50	38.20
2	5150.00	41.5 AV	54.0	-12.5	1.07 V	135	3.30	38.20
3	*5260.00	99.6 PK			1.07 V	135	61.30	38.30
4	*5260.00	88.7 AV			1.07 V	135	50.40	38.30
5	#10520.00	56.6 PK	68.3	-11.7	1.23 V	319	8.30	48.30

**REMARKS:**

1. Emission level (dBuV/m) = Raw Value (dBuV) + Correction Factor (dB/m).
2. Correction Factor (dB/m) = Antenna Factor (dB/m) + Cable Factor (dB).
3. The other emission levels were very low against the limit.
4. Margin value = Emission level – Limit value.
5. “ \* “: Fundamental frequency.
6. “#”:The radiated frequency is out the restricted band.



A D T

EUT TEST CONDITION		MEASUREMENT DETAIL	
CHANNEL	Channel 60	FREQUENCY RANGE	1 ~ 40GHz
INPUT POWER	120Vac, 60 Hz	DETECTOR FUNCTION	Peak (PK) Average (AV)
ENVIRONMENTAL CONDITIONS	25deg. C, 68%RH	TESTED BY	Anderson Hong

ANTENNA POLARITY & TEST DISTANCE: HORIZONTAL AT 3 M								
NO.	FREQ. (MHz)	EMISSION LEVEL (dBuV/m)	LIMIT (dBuV/m)	MARGIN (dB)	ANTENNA HEIGHT (m)	TABLE ANGLE (Degree)	RAW VALUE (dBuV)	CORRECTION FACTOR (dB/m)
1	*5300.00	105.0 PK			1.15 H	127	66.60	38.40
2	*5300.00	93.9 AV			1.15 H	127	55.50	38.40
3	10600.00	54.8 PK	74.0	-19.2	1.03 H	91	6.50	48.30
4	10600.00	42.1 AV	54.0	-11.9	1.03 H	91	-6.20	48.30
5	15900.00	58.4 PK	74.0	-15.6	1.32 H	50	10.00	48.40
6	15900.00	45.5 AV	54.0	-8.5	1.32 H	50	-2.90	48.40
ANTENNA POLARITY & TEST DISTANCE: VERTICAL AT 3 M								
NO.	FREQ. (MHz)	EMISSION LEVEL (dBuV/m)	LIMIT (dBuV/m)	MARGIN (dB)	ANTENNA HEIGHT (m)	TABLE ANGLE (Degree)	RAW VALUE (dBuV)	CORRECTION FACTOR (dB/m)
1	*5300.00	100.0 PK			1.05 V	140	61.60	38.40
2	*5300.00	99.0 AV			1.05 V	140	60.60	38.40
3	10600.00	54.5 PK	74.0	-19.5	1.21 V	322	6.20	48.30
4	10600.00	41.9 AV	54.0	-12.1	1.21 V	322	-6.40	48.30
5	15900.00	58.1 PK	74.0	-15.9	1.12 V	280	9.70	48.40
6	15900.00	45.5 AV	54.0	-8.5	1.12 V	280	-2.90	48.40

**REMARKS:**

1. Emission level (dBuV/m) = Raw Value (dBuV) + Correction Factor (dB/m).
2. Correction Factor (dB/m) = Antenna Factor (dB/m) + Cable Factor (dB).
3. The other emission levels were very low against the limit.
4. Margin value = Emission level – Limit value.
5. “ \* ”: Fundamental frequency.



A D T

EUT TEST CONDITION		MEASUREMENT DETAIL	
CHANNEL	Channel 64	FREQUENCY RANGE	1 ~ 40GHz
INPUT POWER	120Vac, 60 Hz	DETECTOR FUNCTION	Peak (PK) Average (AV)
ENVIRONMENTAL CONDITIONS	25deg. C, 68%RH	TESTED BY	Anderson Hong

ANTENNA POLARITY & TEST DISTANCE: HORIZONTAL AT 3 M								
NO.	FREQ. (MHz)	EMISSION LEVEL (dBuV/m)	LIMIT (dBuV/m)	MARGIN (dB)	ANTENNA HEIGHT (m)	TABLE ANGLE (Degree)	RAW VALUE (dBuV)	CORRECTION FACTOR (dB/m)
1	*5320.00	105.4 PK			1.12 H	126	67.00	38.40
2	*5320.00	94.4 AV			1.12 H	126	56.00	38.40
3	5350.00	65.7 PK	74.0	-8.3	1.12 H	126	27.20	38.50
4	5350.00	49.6 AV	54.0	-4.4	1.12 H	126	11.10	38.50
5	10640.00	55.0 PK	74.0	-19.0	1.00 H	96	6.50	48.50
6	10640.00	42.4 AV	54.0	-11.6	1.00 H	96	-6.10	48.50
ANTENNA POLARITY & TEST DISTANCE: VERTICAL AT 3 M								
NO.	FREQ. (MHz)	EMISSION LEVEL (dBuV/m)	LIMIT (dBuV/m)	MARGIN (dB)	ANTENNA HEIGHT (m)	TABLE ANGLE (Degree)	RAW VALUE (dBuV)	CORRECTION FACTOR (dB/m)
1	*5320.00	100.0 PK			1.05 V	130	61.60	38.40
2	*5320.00	89.1 AV			1.05 V	130	50.70	38.40
3	5350.00	61.4 PK	74.0	-12.6	1.05 V	130	22.90	38.50
4	5350.00	46.4 AV	54.0	-7.6	1.05 V	130	7.90	38.50
5	10640.00	54.8 PK	74.0	-19.2	1.23 V	325	6.30	48.50
6	10640.00	42.2 AV	54.0	-11.8	1.23 V	325	-6.30	48.50

**REMARKS:**

1. Emission level (dBuV/m) = Raw Value (dBuV) + Correction Factor (dB/m).
2. Correction Factor (dB/m) = Antenna Factor (dB/m) + Cable Factor (dB).
3. The other emission levels were very low against the limit.
4. Margin value = Emission level – Limit value.
5. “ \* “: Fundamental frequency.



A D T

EUT TEST CONDITION		MEASUREMENT DETAIL	
CHANNEL	Channel 100	FREQUENCY RANGE	1 ~ 40GHz
INPUT POWER	120Vac, 60 Hz	DETECTOR FUNCTION	Peak (PK) Average (AV)
ENVIRONMENTAL CONDITIONS	25deg. C, 68%RH	TESTED BY	Anderson Hong

ANTENNA POLARITY & TEST DISTANCE: HORIZONTAL AT 3 M								
NO.	FREQ. (MHz)	EMISSION LEVEL (dBuV/m)	LIMIT (dBuV/m)	MARGIN (dB)	ANTENNA HEIGHT (m)	TABLE ANGLE (Degree)	RAW VALUE (dBuV)	CORRECTION FACTOR (dB/m)
1	5460.00	59.8 PK	74.0	-14.2	1.08 H	319	21.10	38.70
2	5460.00	41.6 AV	54.0	-12.4	1.08 H	319	2.90	38.70
3	#5470.00	67.3 PK	68.3	-1.0	1.08 H	319	28.60	38.70
4	*5500.00	105.8 PK			1.08 H	319	67.10	38.70
5	*5500.00	94.9 AV			1.08 H	319	56.20	38.70
6	11000.00	55.1 PK	74.0	-18.9	1.25 H	218	5.90	49.20
7	11000.00	44.3 AV	54.0	-9.7	1.25 H	218	-4.90	49.20
ANTENNA POLARITY & TEST DISTANCE: VERTICAL AT 3 M								
NO.	FREQ. (MHz)	EMISSION LEVEL (dBuV/m)	LIMIT (dBuV/m)	MARGIN (dB)	ANTENNA HEIGHT (m)	TABLE ANGLE (Degree)	RAW VALUE (dBuV)	CORRECTION FACTOR (dB/m)
1	5460.00	57.0 PK	74.0	-17.0	1.06 V	337	18.30	38.70
2	5460.00	39.2 AV	54.0	-14.8	1.06 V	337	0.50	38.70
3	#5470.00	63.8 PK	68.3	-4.5	1.06 V	337	25.10	38.70
4	*5500.00	103.3 PK			1.06 V	337	64.60	38.70
5	*5500.00	92.2 AV			1.06 V	337	53.50	38.70
6	11000.00	55.6 PK	74.0	-18.4	1.15 V	301	6.40	49.20
7	11000.00	45.1 AV	54.0	-8.9	1.15 V	301	-4.10	49.20

**REMARKS:**

1. Emission level (dBuV/m) = Raw Value (dBuV) + Correction Factor (dB/m).
2. Correction Factor (dB/m) = Antenna Factor (dB/m) + Cable Factor (dB).
3. The other emission levels were very low against the limit.
4. Margin value = Emission level – Limit value.
5. “ \* “: Fundamental frequency.
6. “#”:The radiated frequency is out the restricted band.



A D T

EUT TEST CONDITION		MEASUREMENT DETAIL	
CHANNEL	Channel 116	FREQUENCY RANGE	1 ~ 40GHz
INPUT POWER	120Vac, 60 Hz	DETECTOR FUNCTION	Peak (PK) Average (AV)
ENVIRONMENTAL CONDITIONS	25deg. C, 68%RH	TESTED BY	Anderson Hong

ANTENNA POLARITY & TEST DISTANCE: HORIZONTAL AT 3 M								
NO.	FREQ. (MHz)	EMISSION LEVEL (dBuV/m)	LIMIT (dBuV/m)	MARGIN (dB)	ANTENNA HEIGHT (m)	TABLE ANGLE (Degree)	RAW VALUE (dBuV)	CORRECTION FACTOR (dB/m)
1	*5580.00	108.4 PK			1.07 H	311	69.50	38.90
2	*5580.00	97.3 AV			1.07 H	311	58.40	38.90
3	11160.00	56.0 PK	74.0	-18.0	1.25 H	213	6.70	49.30
4	11160.00	45.0 AV	54.0	-9.0	1.25 H	213	-4.30	49.30
5	#16740.00	58.5 PK	68.3	-9.8	1.04 H	138	7.00	51.50
ANTENNA POLARITY & TEST DISTANCE: VERTICAL AT 3 M								
NO.	FREQ. (MHz)	EMISSION LEVEL (dBuV/m)	LIMIT (dBuV/m)	MARGIN (dB)	ANTENNA HEIGHT (m)	TABLE ANGLE (Degree)	RAW VALUE (dBuV)	CORRECTION FACTOR (dB/m)
1	*5580.00	105.3 PK			1.04 V	339	66.40	38.90
2	*5580.00	94.3 AV			1.04 V	339	55.40	38.90
3	11160.00	56.4 PK	74.0	-17.6	1.11 V	308	7.10	49.30
4	11160.00	45.9 AV	54.0	-8.1	1.11 V	308	-3.40	49.30
5	#16740.00	58.4 PK	68.3	-9.9	1.04 V	131	6.90	51.50

**REMARKS:**

1. Emission level (dBuV/m) = Raw Value (dBuV) + Correction Factor (dB/m).
2. Correction Factor (dB/m) = Antenna Factor (dB/m) + Cable Factor (dB).
3. The other emission levels were very low against the limit.
4. Margin value = Emission level – Limit value.
5. “ \* “: Fundamental frequency.
6. “#”:The radiated frequency is out the restricted band.



A D T

EUT TEST CONDITION		MEASUREMENT DETAIL	
CHANNEL	Channel 140	FREQUENCY RANGE	1 ~ 40GHz
INPUT POWER	120Vac, 60 Hz	DETECTOR FUNCTION	Peak (PK) Average (AV)
ENVIRONMENTAL CONDITIONS	25deg. C, 68%RH	TESTED BY	Anderson Hong

ANTENNA POLARITY & TEST DISTANCE: HORIZONTAL AT 3 M								
NO.	FREQ. (MHz)	EMISSION LEVEL (dBuV/m)	LIMIT (dBuV/m)	MARGIN (dB)	ANTENNA HEIGHT (m)	TABLE ANGLE (Degree)	RAW VALUE (dBuV)	CORRECTION FACTOR (dB/m)
1	*5700.00	106.6 PK			1.14 H	308	67.40	39.20
2	*5700.00	95.5 AV			1.14 H	308	56.30	39.20
3	#5725.00	67.3 PK	68.3	-1.0	1.14 H	308	28.10	39.20
4	11400.00	56.0 PK	74.0	-18.0	1.25 H	213	6.70	49.30
5	11400.00	45.0 AV	54.0	-9.0	1.25 H	213	-4.30	49.30
ANTENNA POLARITY & TEST DISTANCE: VERTICAL AT 3 M								
NO.	FREQ. (MHz)	EMISSION LEVEL (dBuV/m)	LIMIT (dBuV/m)	MARGIN (dB)	ANTENNA HEIGHT (m)	TABLE ANGLE (Degree)	RAW VALUE (dBuV)	CORRECTION FACTOR (dB/m)
1	*5700.00	102.8 PK			1.02 V	342	63.60	39.20
2	*5700.00	91.9 AV			1.02 V	342	52.70	39.20
3	#5725.00	63.6 PK	68.3	-4.7	1.02 V	342	24.40	39.20
4	11400.00	56.3 PK	74.0	-17.7	1.12 V	316	7.00	49.30
5	11400.00	45.7 AV	54.0	-8.3	1.12 V	316	-3.60	49.30

**REMARKS:**

1. Emission level (dBuV/m) = Raw Value (dBuV) + Correction Factor (dB/m).
2. Correction Factor (dB/m) = Antenna Factor (dB/m) + Cable Factor (dB).
3. The other emission levels were very low against the limit.
4. Margin value = Emission level – Limit value.
5. “ \* “: Fundamental frequency.
6. “#”:The radiated frequency is out the restricted band.

## Test Mode C1 (Without MSR & Aux Ant.)

802.11a

EUT TEST CONDITION		MEASUREMENT DETAIL	
CHANNEL	Channel 36	FREQUENCY RANGE	1 ~ 40GHz
INPUT POWER	120Vac, 60 Hz	DETECTOR FUNCTION	Peak (PK) Average (AV)
ENVIRONMENTAL CONDITIONS	25deg. C, 68%RH	TESTED BY	Anderson Hong

ANTENNA POLARITY & TEST DISTANCE: HORIZONTAL AT 3 M								
NO.	FREQ. (MHz)	EMISSION LEVEL (dBuV/m)	LIMIT (dBuV/m)	MARGIN (dB)	ANTENNA HEIGHT (m)	TABLE ANGLE (Degree)	RAW VALUE (dBuV)	CORRECTION FACTOR (dB/m)
1	5150.00	66.5 PK	74.0	-7.5	1.00 H	161	28.30	38.20
2	5150.00	48.9 AV	54.0	-5.1	1.00 H	161	10.70	38.20
3	*5180.00	104.2 PK			1.00 H	161	66.00	38.20
4	*5180.00	93.2 AV			1.00 H	161	55.00	38.20
5	#10360.00	54.5 PK	68.3	-13.8	1.00 H	290	6.50	48.00
ANTENNA POLARITY & TEST DISTANCE: VERTICAL AT 3 M								
NO.	FREQ. (MHz)	EMISSION LEVEL (dBuV/m)	LIMIT (dBuV/m)	MARGIN (dB)	ANTENNA HEIGHT (m)	TABLE ANGLE (Degree)	RAW VALUE (dBuV)	CORRECTION FACTOR (dB/m)
1	5150.00	59.0 PK	74.0	-15.0	1.00 V	259	20.80	38.20
2	5150.00	42.5 AV	54.0	-11.5	1.00 V	259	4.30	38.20
3	*5180.00	95.5 PK			1.00 V	259	57.30	38.20
4	*5180.00	84.6 AV			1.00 V	259	46.40	38.20
5	#10360.00	54.2 PK	68.3	-14.1	1.37 V	57	6.20	48.00

### REMARKS:

1. Emission level (dBuV/m) = Raw Value (dBuV) + Correction Factor (dB/m).
2. Correction Factor (dB/m) = Antenna Factor (dB/m) + Cable Factor (dB).
3. The other emission levels were very low against the limit.
4. Margin value = Emission level – Limit value.
5. " \* ": Fundamental frequency.
6. "#": The radiated frequency is out the restricted band.



A D T

EUT TEST CONDITION		MEASUREMENT DETAIL	
CHANNEL	Channel 40	FREQUENCY RANGE	1 ~ 40GHz
INPUT POWER	120Vac, 60 Hz	DETECTOR FUNCTION	Peak (PK) Average (AV)
ENVIRONMENTAL CONDITIONS	25deg. C, 68%RH	TESTED BY	Anderson Hong

ANTENNA POLARITY & TEST DISTANCE: HORIZONTAL AT 3 M								
NO.	FREQ. (MHz)	EMISSION LEVEL (dBuV/m)	LIMIT (dBuV/m)	MARGIN (dB)	ANTENNA HEIGHT (m)	TABLE ANGLE (Degree)	RAW VALUE (dBuV)	CORRECTION FACTOR (dB/m)
1	*5200.00	104.0 PK			1.00 H	158	65.80	38.20
2	*5200.00	93.0 AV			1.00 H	158	54.80	38.20
3	#10400.00	54.8 PK	68.3	-13.5	1.00 H	293	6.70	48.10
4	15600.00	56.9 PK	74.0	-17.1	1.25 H	138	7.80	49.10
5	15600.00	44.0 AV	54.0	-10.0	1.25 H	138	-5.10	49.10
ANTENNA POLARITY & TEST DISTANCE: VERTICAL AT 3 M								
NO.	FREQ. (MHz)	EMISSION LEVEL (dBuV/m)	LIMIT (dBuV/m)	MARGIN (dB)	ANTENNA HEIGHT (m)	TABLE ANGLE (Degree)	RAW VALUE (dBuV)	CORRECTION FACTOR (dB/m)
1	*5200.00	96.0 PK			1.00 V	255	57.80	38.20
2	*5200.00	85.0 AV			1.00 V	255	46.80	38.20
3	#10400.00	54.5 PK	68.3	-13.8	1.34 V	55	6.40	48.10
4	15600.00	56.8 PK	74.0	-17.2	1.00 V	223	7.70	49.10
5	15600.00	43.7 AV	54.0	-10.3	1.00 V	223	-5.40	49.10

**REMARKS:**

1. Emission level (dBuV/m) = Raw Value (dBuV) + Correction Factor (dB/m).
2. Correction Factor (dB/m) = Antenna Factor (dB/m) + Cable Factor (dB).
3. The other emission levels were very low against the limit.
4. Margin value = Emission level – Limit value.
5. “ \* “: Fundamental frequency.
6. “#”:The radiated frequency is out the restricted band.





A D T

EUT TEST CONDITION		MEASUREMENT DETAIL	
CHANNEL	Channel 48	FREQUENCY RANGE	1 ~ 40GHz
INPUT POWER	120Vac, 60 Hz	DETECTOR FUNCTION	Peak (PK) Average (AV)
ENVIRONMENTAL CONDITIONS	25deg. C, 68%RH	TESTED BY	Anderson Hong

ANTENNA POLARITY & TEST DISTANCE: HORIZONTAL AT 3 M								
NO.	FREQ. (MHz)	EMISSION LEVEL (dBuV/m)	LIMIT (dBuV/m)	MARGIN (dB)	ANTENNA HEIGHT (m)	TABLE ANGLE (Degree)	RAW VALUE (dBuV)	CORRECTION FACTOR (dB/m)
1	*5240.00	104.3 PK			1.00 H	154	66.00	38.30
2	*5240.00	93.0 AV			1.00 H	154	54.70	38.30
3	5350.00	52.7 PK	74.0	-21.3	1.00 H	154	14.20	38.50
4	5350.00	40.1 AV	54.0	-13.9	1.00 H	154	1.60	38.50
5	#10480.00	54.9 PK	68.3	-13.4	1.00 H	294	6.70	48.20
ANTENNA POLARITY & TEST DISTANCE: VERTICAL AT 3 M								
NO.	FREQ. (MHz)	EMISSION LEVEL (dBuV/m)	LIMIT (dBuV/m)	MARGIN (dB)	ANTENNA HEIGHT (m)	TABLE ANGLE (Degree)	RAW VALUE (dBuV)	CORRECTION FACTOR (dB/m)
1	*5240.00	98.5 PK			1.00 V	253	60.20	38.30
2	*5240.00	87.5 AV			1.00 V	253	49.20	38.30
3	5350.00	51.6 PK	74.0	-22.4	1.00 V	253	13.10	38.50
4	5350.00	39.6 AV	54.0	-14.4	1.00 V	253	1.10	38.50
5	#10480.00	55.4 PK	68.3	-12.9	1.35 V	55	7.20	48.20

**REMARKS:**

1. Emission level (dBuV/m) = Raw Value (dBuV) + Correction Factor (dB/m).
2. Correction Factor (dB/m) = Antenna Factor (dB/m) + Cable Factor (dB).
3. The other emission levels were very low against the limit.
4. Margin value = Emission level – Limit value.
5. “ \* “: Fundamental frequency.
6. “#”:The radiated frequency is out the restricted band.



A D T

EUT TEST CONDITION		MEASUREMENT DETAIL	
CHANNEL	Channel 52	FREQUENCY RANGE	1 ~ 40GHz
INPUT POWER	120Vac, 60 Hz	DETECTOR FUNCTION	Peak (PK) Average (AV)
ENVIRONMENTAL CONDITIONS	25deg. C, 68%RH	TESTED BY	Anderson Hong

ANTENNA POLARITY & TEST DISTANCE: HORIZONTAL AT 3 M								
NO.	FREQ. (MHz)	EMISSION LEVEL (dBuV/m)	LIMIT (dBuV/m)	MARGIN (dB)	ANTENNA HEIGHT (m)	TABLE ANGLE (Degree)	RAW VALUE (dBuV)	CORRECTION FACTOR (dB/m)
1	5150.00	54.4 PK	74.0	-19.6	1.00 H	159	16.20	38.20
2	5150.00	41.6 AV	54.0	-12.4	1.00 H	159	3.40	38.20
3	*5260.00	108.9 PK			1.00 H	159	70.60	38.30
4	*5260.00	97.7 AV			1.00 H	159	59.40	38.30
5	#10520.00	57.1 PK	68.3	-11.2	1.00 H	291	8.80	48.30
ANTENNA POLARITY & TEST DISTANCE: VERTICAL AT 3 M								
NO.	FREQ. (MHz)	EMISSION LEVEL (dBuV/m)	LIMIT (dBuV/m)	MARGIN (dB)	ANTENNA HEIGHT (m)	TABLE ANGLE (Degree)	RAW VALUE (dBuV)	CORRECTION FACTOR (dB/m)
1	5150.00	53.5 PK	74.0	-20.5	1.12 V	243	15.30	38.20
2	5150.00	41.4 AV	54.0	-12.6	1.12 V	243	3.20	38.20
3	*5260.00	102.3 PK			1.12 V	243	64.00	38.30
4	*5260.00	91.4 AV			1.12 V	243	53.10	38.30
5	#10520.00	57.7 PK	68.3	-10.6	1.38 V	51	9.40	48.30

**REMARKS:**

1. Emission level (dBuV/m) = Raw Value (dBuV) + Correction Factor (dB/m).
2. Correction Factor (dB/m) = Antenna Factor (dB/m) + Cable Factor (dB).
3. The other emission levels were very low against the limit.
4. Margin value = Emission level – Limit value.
5. “ \* “: Fundamental frequency.
6. “#”:The radiated frequency is out the restricted band.



A D T

EUT TEST CONDITION		MEASUREMENT DETAIL	
CHANNEL	Channel 60	FREQUENCY RANGE	1 ~ 40GHz
INPUT POWER	120Vac, 60 Hz	DETECTOR FUNCTION	Peak (PK) Average (AV)
ENVIRONMENTAL CONDITIONS	25deg. C, 68%RH	TESTED BY	Anderson Hong

ANTENNA POLARITY & TEST DISTANCE: HORIZONTAL AT 3 M								
NO.	FREQ. (MHz)	EMISSION LEVEL (dBuV/m)	LIMIT (dBuV/m)	MARGIN (dB)	ANTENNA HEIGHT (m)	TABLE ANGLE (Degree)	RAW VALUE (dBuV)	CORRECTION FACTOR (dB/m)
1	*5300.00	108.1 PK			1.00 H	161	69.70	38.40
2	*5300.00	96.9 AV			1.00 H	161	58.50	38.40
3	10600.00	55.1 PK	74.0	-18.9	1.00 H	300	6.80	48.30
4	10600.00	42.1 AV	54.0	-11.9	1.00 H	300	-6.20	48.30
5	15900.00	59.0 PK	74.0	-15.0	1.25 H	139	10.60	48.40
6	15900.00	46.2 AV	54.0	-7.8	1.25 H	139	-2.20	48.40
ANTENNA POLARITY & TEST DISTANCE: VERTICAL AT 3 M								
NO.	FREQ. (MHz)	EMISSION LEVEL (dBuV/m)	LIMIT (dBuV/m)	MARGIN (dB)	ANTENNA HEIGHT (m)	TABLE ANGLE (Degree)	RAW VALUE (dBuV)	CORRECTION FACTOR (dB/m)
1	*5300.00	106.2 PK			1.15 V	219	67.80	38.40
2	*5300.00	95.1 AV			1.15 V	219	56.70	38.40
3	10600.00	56.0 PK	74.0	-18.0	1.38 V	55	7.70	48.30
4	10600.00	42.3 AV	54.0	-11.7	1.38 V	55	-6.00	48.30
5	15900.00	59.7 PK	74.0	-14.3	1.00 V	231	11.30	48.40
6	15900.00	46.5 AV	54.0	-7.5	1.00 V	231	-1.90	48.40

**REMARKS:**

1. Emission level (dBuV/m) = Raw Value (dBuV) + Correction Factor (dB/m).
2. Correction Factor (dB/m) = Antenna Factor (dB/m) + Cable Factor (dB).
3. The other emission levels were very low against the limit.
4. Margin value = Emission level – Limit value.
5. “ \* ”: Fundamental frequency.



A D T

EUT TEST CONDITION		MEASUREMENT DETAIL	
CHANNEL	Channel 64	FREQUENCY RANGE	1 ~ 40GHz
INPUT POWER	120Vac, 60 Hz	DETECTOR FUNCTION	Peak (PK) Average (AV)
ENVIRONMENTAL CONDITIONS	25deg. C, 68%RH	TESTED BY	Anderson Hong

ANTENNA POLARITY & TEST DISTANCE: HORIZONTAL AT 3 M								
NO.	FREQ. (MHz)	EMISSION LEVEL (dBuV/m)	LIMIT (dBuV/m)	MARGIN (dB)	ANTENNA HEIGHT (m)	TABLE ANGLE (Degree)	RAW VALUE (dBuV)	CORRECTION FACTOR (dB/m)
1	*5320.00	107.2 PK			1.00 H	157	68.80	38.40
2	*5320.00	96.2 AV			1.00 H	157	57.80	38.40
3	5350.00	70.4 PK	74.0	-3.6	1.00 H	157	31.90	38.50
4	5350.00	51.6 AV	54.0	-2.4	1.00 H	157	13.10	38.50
5	10640.00	54.2 PK	74.0	-19.8	1.00 H	302	5.70	48.50
6	10640.00	41.3 AV	54.0	-12.7	1.00 H	302	-7.20	48.50
ANTENNA POLARITY & TEST DISTANCE: VERTICAL AT 3 M								
NO.	FREQ. (MHz)	EMISSION LEVEL (dBuV/m)	LIMIT (dBuV/m)	MARGIN (dB)	ANTENNA HEIGHT (m)	TABLE ANGLE (Degree)	RAW VALUE (dBuV)	CORRECTION FACTOR (dB/m)
1	*5320.00	106.6 PK			1.13 V	220	68.20	38.40
2	*5320.00	95.6 AV			1.13 V	220	57.20	38.40
3	5350.00	69.1 PK	74.0	-4.9	1.13 V	220	30.60	38.50
4	5350.00	51.4 AV	54.0	-2.6	1.13 V	220	12.90	38.50
5	10640.00	55.2 PK	74.0	-18.8	1.35 V	53	6.70	48.50
6	10640.00	41.6 AV	54.0	-12.4	1.35 V	53	-6.90	48.50

**REMARKS:**

1. Emission level (dBuV/m) = Raw Value (dBuV) + Correction Factor (dB/m).
2. Correction Factor (dB/m) = Antenna Factor (dB/m) + Cable Factor (dB).
3. The other emission levels were very low against the limit.
4. Margin value = Emission level – Limit value.
5. “ \* “: Fundamental frequency.



A D T

EUT TEST CONDITION		MEASUREMENT DETAIL	
CHANNEL	Channel 100	FREQUENCY RANGE	1 ~ 40GHz
INPUT POWER	120Vac, 60 Hz	DETECTOR FUNCTION	Peak (PK) Average (AV)
ENVIRONMENTAL CONDITIONS	25deg. C, 68%RH	TESTED BY	Anderson Hong

ANTENNA POLARITY & TEST DISTANCE: HORIZONTAL AT 3 M								
NO.	FREQ. (MHz)	EMISSION LEVEL (dBuV/m)	LIMIT (dBuV/m)	MARGIN (dB)	ANTENNA HEIGHT (m)	TABLE ANGLE (Degree)	RAW VALUE (dBuV)	CORRECTION FACTOR (dB/m)
1	5460.00	60.6 PK	74.0	-13.4	1.07 H	21	21.90	38.70
2	5460.00	45.2 AV	54.0	-8.8	1.07 H	21	6.50	38.70
3	#5470.00	65.7 PK	68.3	-2.6	1.07 H	21	27.00	38.70
4	*5500.00	105.7 PK			1.07 H	21	67.00	38.70
5	*5500.00	94.6 AV			1.07 H	21	55.90	38.70
6	11000.00	54.5 PK	74.0	-19.5	1.00 H	305	5.30	49.20
7	11000.00	41.6 AV	54.0	-12.4	1.00 H	305	-7.60	49.20
ANTENNA POLARITY & TEST DISTANCE: VERTICAL AT 3 M								
NO.	FREQ. (MHz)	EMISSION LEVEL (dBuV/m)	LIMIT (dBuV/m)	MARGIN (dB)	ANTENNA HEIGHT (m)	TABLE ANGLE (Degree)	RAW VALUE (dBuV)	CORRECTION FACTOR (dB/m)
1	5460.00	59.9 PK	74.0	-14.1	1.00 V	14	21.20	38.70
2	5460.00	45.3 AV	54.0	-8.7	1.00 V	14	6.60	38.70
3	#5470.00	67.3 PK	68.3	-1.0	1.00 V	14	28.60	38.70
4	*5500.00	108.7 PK			1.00 V	14	70.00	38.70
5	*5500.00	97.5 AV			1.00 V	14	58.80	38.70
6	11000.00	55.5 PK	74.0	-18.5	1.41 V	59	6.30	49.20
7	11000.00	42.0 AV	54.0	-12.0	1.41 V	59	-7.20	49.20

**REMARKS:**

1. Emission level (dBuV/m) = Raw Value (dBuV) + Correction Factor (dB/m).
2. Correction Factor (dB/m) = Antenna Factor (dB/m) + Cable Factor (dB).
3. The other emission levels were very low against the limit.
4. Margin value = Emission level – Limit value.
5. “ \* “: Fundamental frequency.
6. “#”:The radiated frequency is out the restricted band.



A D T

EUT TEST CONDITION		MEASUREMENT DETAIL	
CHANNEL	Channel 116	FREQUENCY RANGE	1 ~ 40GHz
INPUT POWER	120Vac, 60 Hz	DETECTOR FUNCTION	Peak (PK) Average (AV)
ENVIRONMENTAL CONDITIONS	25deg. C, 68%RH	TESTED BY	Anderson Hong

ANTENNA POLARITY & TEST DISTANCE: HORIZONTAL AT 3 M								
NO.	FREQ. (MHz)	EMISSION LEVEL (dBuV/m)	LIMIT (dBuV/m)	MARGIN (dB)	ANTENNA HEIGHT (m)	TABLE ANGLE (Degree)	RAW VALUE (dBuV)	CORRECTION FACTOR (dB/m)
1	*5580.00	107.4 PK			1.05 H	25	68.50	38.90
2	*5580.00	96.3 AV			1.05 H	25	57.40	38.90
3	11160.00	55.4 PK	74.0	-18.6	1.00 H	305	6.10	49.30
4	11160.00	42.5 AV	54.0	-11.5	1.00 H	305	-6.80	49.30
5	#16740.00	60.6 PK	68.3	-7.7	1.00 H	31	9.10	51.50
ANTENNA POLARITY & TEST DISTANCE: VERTICAL AT 3 M								
NO.	FREQ. (MHz)	EMISSION LEVEL (dBuV/m)	LIMIT (dBuV/m)	MARGIN (dB)	ANTENNA HEIGHT (m)	TABLE ANGLE (Degree)	RAW VALUE (dBuV)	CORRECTION FACTOR (dB/m)
1	*5580.00	111.8 PK			1.00 V	16	72.90	38.90
2	*5580.00	100.6 AV			1.00 V	16	61.70	38.90
3	11160.00	56.4 PK	74.0	-17.6	1.40 V	60	7.10	49.30
4	11160.00	43.1 AV	54.0	-10.9	1.40 V	60	-6.20	49.30
5	#16740.00	61.0 PK	68.3	-7.3	1.21 V	223	9.50	51.50

**REMARKS:**

1. Emission level (dBuV/m) = Raw Value (dBuV) + Correction Factor (dB/m).
2. Correction Factor (dB/m) = Antenna Factor (dB/m) + Cable Factor (dB).
3. The other emission levels were very low against the limit.
4. Margin value = Emission level – Limit value.
5. “ \* “: Fundamental frequency.
6. “#”:The radiated frequency is out the restricted band.



A D T

EUT TEST CONDITION		MEASUREMENT DETAIL	
CHANNEL	Channel 140	FREQUENCY RANGE	1 ~ 40GHz
INPUT POWER	120Vac, 60 Hz	DETECTOR FUNCTION	Peak (PK) Average (AV)
ENVIRONMENTAL CONDITIONS	25deg. C, 68%RH	TESTED BY	Anderson Hong

ANTENNA POLARITY & TEST DISTANCE: HORIZONTAL AT 3 M								
NO.	FREQ. (MHz)	EMISSION LEVEL (dBuV/m)	LIMIT (dBuV/m)	MARGIN (dB)	ANTENNA HEIGHT (m)	TABLE ANGLE (Degree)	RAW VALUE (dBuV)	CORRECTION FACTOR (dB/m)
1	*5700.00	103.3 PK			1.24 H	72	64.10	39.20
2	*5700.00	92.3 AV			1.24 H	72	53.10	39.20
3	#5725.00	63.7 PK	68.3	-4.6	1.24 H	72	24.50	39.20
4	11400.00	54.3 PK	74.0	-19.7	1.00 H	308	5.00	49.30
5	11400.00	41.4 AV	54.0	-12.6	1.00 H	308	-7.90	49.30
ANTENNA POLARITY & TEST DISTANCE: VERTICAL AT 3 M								
NO.	FREQ. (MHz)	EMISSION LEVEL (dBuV/m)	LIMIT (dBuV/m)	MARGIN (dB)	ANTENNA HEIGHT (m)	TABLE ANGLE (Degree)	RAW VALUE (dBuV)	CORRECTION FACTOR (dB/m)
1	*5700.00	107.4 PK			1.00 V	11	68.20	39.20
2	*5700.00	96.4 AV			1.00 V	11	57.20	39.20
3	#5725.00	67.0 PK	68.3	-1.3	1.00 V	11	27.80	39.20
4	11400.00	55.6 PK	74.0	-18.4	1.40 V	61	6.30	49.30
5	11400.00	42.1 AV	54.0	-11.9	1.40 V	61	-7.20	49.30

**REMARKS:**

1. Emission level (dBuV/m) = Raw Value (dBuV) + Correction Factor (dB/m).
2. Correction Factor (dB/m) = Antenna Factor (dB/m) + Cable Factor (dB).
3. The other emission levels were very low against the limit.
4. Margin value = Emission level – Limit value.
5. “ \* “: Fundamental frequency.
6. “#”:The radiated frequency is out the restricted band.



A D T

### 802.11n (20MHz)

EUT TEST CONDITION		MEASUREMENT DETAIL	
CHANNEL	Channel 36	FREQUENCY RANGE	1 ~ 40GHz
INPUT POWER	120Vac, 60 Hz	DETECTOR FUNCTION	Peak (PK) Average (AV)
ENVIRONMENTAL CONDITIONS	25deg. C, 68%RH	TESTED BY	Anderson Hong

ANTENNA POLARITY & TEST DISTANCE: HORIZONTAL AT 3 M								
NO.	FREQ. (MHz)	EMISSION LEVEL (dBuV/m)	LIMIT (dBuV/m)	MARGIN (dB)	ANTENNA HEIGHT (m)	TABLE ANGLE (Degree)	RAW VALUE (dBuV)	CORRECTION FACTOR (dB/m)
1	5150.00	64.7 PK	74.0	-9.3	1.03 H	335	26.50	38.20
2	5150.00	48.2 AV	54.0	-5.8	1.03 H	335	10.00	38.20
3	*5180.00	102.7 PK			1.03 H	335	64.50	38.20
4	*5180.00	91.7 AV			1.03 H	335	53.50	38.20
5	#10360.00	53.6 PK	68.3	-14.7	1.00 H	80	5.60	48.00

ANTENNA POLARITY & TEST DISTANCE: VERTICAL AT 3 M								
NO.	FREQ. (MHz)	EMISSION LEVEL (dBuV/m)	LIMIT (dBuV/m)	MARGIN (dB)	ANTENNA HEIGHT (m)	TABLE ANGLE (Degree)	RAW VALUE (dBuV)	CORRECTION FACTOR (dB/m)
1	5150.00	60.0 PK	74.0	-14.0	1.08 V	355	21.80	38.20
2	5150.00	44.6 AV	54.0	-9.4	1.08 V	355	6.40	38.20
3	*5180.00	99.0 PK			1.08 V	355	60.80	38.20
4	*5180.00	88.1 AV			1.08 V	355	49.90	38.20
5	#10360.00	54.1 PK	68.3	-14.2	1.23 V	210	6.10	48.00

#### REMARKS:

1. Emission level (dBuV/m) = Raw Value (dBuV) + Correction Factor (dB/m).
2. Correction Factor (dB/m) = Antenna Factor (dB/m) + Cable Factor (dB).
3. The other emission levels were very low against the limit.
4. Margin value = Emission level – Limit value.
5. " \* ": Fundamental frequency.
6. "#": The radiated frequency is out the restricted band.





A D T

EUT TEST CONDITION		MEASUREMENT DETAIL	
CHANNEL	Channel 40	FREQUENCY RANGE	1 ~ 40GHz
INPUT POWER	120Vac, 60 Hz	DETECTOR FUNCTION	Peak (PK) Average (AV)
ENVIRONMENTAL CONDITIONS	25deg. C, 68%RH	TESTED BY	Anderson Hong

ANTENNA POLARITY & TEST DISTANCE: HORIZONTAL AT 3 M								
NO.	FREQ. (MHz)	EMISSION LEVEL (dBuV/m)	LIMIT (dBuV/m)	MARGIN (dB)	ANTENNA HEIGHT (m)	TABLE ANGLE (Degree)	RAW VALUE (dBuV)	CORRECTION FACTOR (dB/m)
1	*5200.00	102.7 PK			1.02 H	336	64.50	38.20
2	*5200.00	91.5 AV			1.02 H	336	53.30	38.20
3	#10400.00	53.9 PK	68.3	-14.4	1.00 H	83	5.80	48.10
4	15600.00	57.0 PK	74.0	-17.0	1.16 H	165	7.90	49.10
5	15600.00	44.1 AV	54.0	-9.9	1.16 H	165	-5.00	49.10
ANTENNA POLARITY & TEST DISTANCE: VERTICAL AT 3 M								
NO.	FREQ. (MHz)	EMISSION LEVEL (dBuV/m)	LIMIT (dBuV/m)	MARGIN (dB)	ANTENNA HEIGHT (m)	TABLE ANGLE (Degree)	RAW VALUE (dBuV)	CORRECTION FACTOR (dB/m)
1	*5200.00	100.2 PK			1.08 V	356	62.00	38.20
2	*5200.00	89.2 AV			1.08 V	356	51.00	38.20
3	#10400.00	54.8 PK	68.3	-13.5	1.24 V	213	6.70	48.10
4	15600.00	56.7 PK	74.0	-17.3	1.00 V	93	7.60	49.10
5	15600.00	43.3 AV	54.0	-10.7	1.00 V	93	-5.80	49.10

**REMARKS:**

1. Emission level (dBuV/m) = Raw Value (dBuV) + Correction Factor (dB/m).
2. Correction Factor (dB/m) = Antenna Factor (dB/m) + Cable Factor (dB).
3. The other emission levels were very low against the limit.
4. Margin value = Emission level – Limit value.
5. “ \* “: Fundamental frequency.
6. “#”:The radiated frequency is out the restricted band.



A D T

EUT TEST CONDITION		MEASUREMENT DETAIL	
CHANNEL	Channel 48	FREQUENCY RANGE	1 ~ 40GHz
INPUT POWER	120Vac, 60 Hz	DETECTOR FUNCTION	Peak (PK) Average (AV)
ENVIRONMENTAL CONDITIONS	25deg. C, 68%RH	TESTED BY	Anderson Hong

ANTENNA POLARITY & TEST DISTANCE: HORIZONTAL AT 3 M								
NO.	FREQ. (MHz)	EMISSION LEVEL (dBuV/m)	LIMIT (dBuV/m)	MARGIN (dB)	ANTENNA HEIGHT (m)	TABLE ANGLE (Degree)	RAW VALUE (dBuV)	CORRECTION FACTOR (dB/m)
1	*5240.00	103.0 PK			1.01 H	336	64.70	38.30
2	*5240.00	91.9 AV			1.01 H	336	53.60	38.30
3	5350.00	53.1 PK	74.0	-20.9	1.01 H	336	14.60	38.50
4	5350.00	40.9 AV	54.0	-13.1	1.01 H	336	2.40	38.50
5	#10480.00	53.6 PK	68.3	-14.7	1.00 H	88	5.40	48.20
ANTENNA POLARITY & TEST DISTANCE: VERTICAL AT 3 M								
NO.	FREQ. (MHz)	EMISSION LEVEL (dBuV/m)	LIMIT (dBuV/m)	MARGIN (dB)	ANTENNA HEIGHT (m)	TABLE ANGLE (Degree)	RAW VALUE (dBuV)	CORRECTION FACTOR (dB/m)
1	*5240.00	100.7 PK			1.06 V	354	62.40	38.30
2	*5240.00	89.7 AV			1.06 V	354	51.40	38.30
3	5350.00	52.0 PK	74.0	-22.0	1.06 V	354	13.50	38.50
4	5350.00	39.9 AV	54.0	-14.1	1.06 V	354	1.40	38.50
5	#10480.00	54.5 PK	68.3	-13.8	1.22 V	211	6.30	48.20

**REMARKS:**

1. Emission level (dBuV/m) = Raw Value (dBuV) + Correction Factor (dB/m).
2. Correction Factor (dB/m) = Antenna Factor (dB/m) + Cable Factor (dB).
3. The other emission levels were very low against the limit.
4. Margin value = Emission level – Limit value.
5. “ \* “: Fundamental frequency.
6. “#”:The radiated frequency is out the restricted band.



A D T

EUT TEST CONDITION		MEASUREMENT DETAIL	
CHANNEL	Channel 52	FREQUENCY RANGE	1 ~ 40GHz
INPUT POWER	120Vac, 60 Hz	DETECTOR FUNCTION	Peak (PK) Average (AV)
ENVIRONMENTAL CONDITIONS	25deg. C, 68%RH	TESTED BY	Anderson Hong

ANTENNA POLARITY & TEST DISTANCE: HORIZONTAL AT 3 M								
NO.	FREQ. (MHz)	EMISSION LEVEL (dBuV/m)	LIMIT (dBuV/m)	MARGIN (dB)	ANTENNA HEIGHT (m)	TABLE ANGLE (Degree)	RAW VALUE (dBuV)	CORRECTION FACTOR (dB/m)
1	5150.00	54.0 PK	74.0	-20.0	1.01 H	337	15.80	38.20
2	5150.00	41.2 AV	54.0	-12.8	1.01 H	337	3.00	38.20
3	*5260.00	106.6 PK			1.01 H	337	68.30	38.30
4	*5260.00	95.5 AV			1.01 H	337	57.20	38.30
5	#10520.00	55.9 PK	68.3	-12.4	1.00 H	83	7.60	48.30
ANTENNA POLARITY & TEST DISTANCE: VERTICAL AT 3 M								
NO.	FREQ. (MHz)	EMISSION LEVEL (dBuV/m)	LIMIT (dBuV/m)	MARGIN (dB)	ANTENNA HEIGHT (m)	TABLE ANGLE (Degree)	RAW VALUE (dBuV)	CORRECTION FACTOR (dB/m)
1	5150.00	53.5 PK	74.0	-20.5	1.07 V	355	15.30	38.20
2	5150.00	40.7 AV	54.0	-13.3	1.07 V	355	2.50	38.20
3	*5260.00	104.5 PK			1.07 V	355	66.20	38.30
4	*5260.00	93.5 AV			1.07 V	355	55.20	38.30
5	#10520.00	55.8 PK	68.3	-12.5	1.20 V	213	7.50	48.30

**REMARKS:**

1. Emission level (dBuV/m) = Raw Value (dBuV) + Correction Factor (dB/m).
2. Correction Factor (dB/m) = Antenna Factor (dB/m) + Cable Factor (dB).
3. The other emission levels were very low against the limit.
4. Margin value = Emission level – Limit value.
5. “ \* “: Fundamental frequency.
6. “#”:The radiated frequency is out the restricted band.



A D T

EUT TEST CONDITION		MEASUREMENT DETAIL	
CHANNEL	Channel 60	FREQUENCY RANGE	1 ~ 40GHz
INPUT POWER	120Vac, 60 Hz	DETECTOR FUNCTION	Peak (PK) Average (AV)
ENVIRONMENTAL CONDITIONS	25deg. C, 68%RH	TESTED BY	Anderson Hong

ANTENNA POLARITY & TEST DISTANCE: HORIZONTAL AT 3 M								
NO.	FREQ. (MHz)	EMISSION LEVEL (dBuV/m)	LIMIT (dBuV/m)	MARGIN (dB)	ANTENNA HEIGHT (m)	TABLE ANGLE (Degree)	RAW VALUE (dBuV)	CORRECTION FACTOR (dB/m)
1	*5300.00	108.0 PK			1.00 H	334	69.60	38.40
2	*5300.00	96.9 AV			1.00 H	334	58.50	38.40
3	10600.00	54.9 PK	74.0	-19.1	1.00 H	303	6.60	48.30
4	10600.00	42.0 AV	54.0	-12.0	1.00 H	303	-6.30	48.30
5	15900.00	58.7 PK	74.0	-15.3	1.28 H	141	10.30	48.40
6	15900.00	45.8 AV	54.0	-8.2	1.28 H	141	-2.60	48.40
ANTENNA POLARITY & TEST DISTANCE: VERTICAL AT 3 M								
NO.	FREQ. (MHz)	EMISSION LEVEL (dBuV/m)	LIMIT (dBuV/m)	MARGIN (dB)	ANTENNA HEIGHT (m)	TABLE ANGLE (Degree)	RAW VALUE (dBuV)	CORRECTION FACTOR (dB/m)
1	*5300.00	106.4 PK			1.07 V	358	68.00	38.40
2	*5300.00	95.2 AV			1.07 V	358	56.80	38.40
3	10600.00	55.7 PK	74.0	-18.3	1.35 V	51	7.40	48.30
4	10600.00	42.0 AV	54.0	-12.0	1.35 V	51	-6.30	48.30
5	15900.00	59.5 PK	74.0	-14.5	1.00 V	235	11.10	48.40
6	15900.00	46.3 AV	54.0	-7.7	1.00 V	235	-2.10	48.40

**REMARKS:**

1. Emission level (dBuV/m) = Raw Value (dBuV) + Correction Factor (dB/m).
2. Correction Factor (dB/m) = Antenna Factor (dB/m) + Cable Factor (dB).
3. The other emission levels were very low against the limit.
4. Margin value = Emission level – Limit value.
5. “ \* ”: Fundamental frequency.



A D T

EUT TEST CONDITION		MEASUREMENT DETAIL	
CHANNEL	Channel 64	FREQUENCY RANGE	1 ~ 40GHz
INPUT POWER	120Vac, 60 Hz	DETECTOR FUNCTION	Peak (PK) Average (AV)
ENVIRONMENTAL CONDITIONS	25deg. C, 68%RH	TESTED BY	Anderson Hong

ANTENNA POLARITY & TEST DISTANCE: HORIZONTAL AT 3 M								
NO.	FREQ. (MHz)	EMISSION LEVEL (dBuV/m)	LIMIT (dBuV/m)	MARGIN (dB)	ANTENNA HEIGHT (m)	TABLE ANGLE (Degree)	RAW VALUE (dBuV)	CORRECTION FACTOR (dB/m)
1	*5320.00	106.9 PK			1.00 H	339	68.50	38.40
2	*5320.00	95.8 AV			1.00 H	339	57.40	38.40
3	5350.00	72.2 PK	74.0	-1.8	1.00 H	339	33.70	38.50
4	5350.00	52.2 AV	54.0	-1.8	1.00 H	339	13.70	38.50
5	10640.00	55.3 PK	74.0	-18.7	1.00 H	301	6.80	48.50
6	10640.00	42.3 AV	54.0	-11.7	1.00 H	301	-6.20	48.50
ANTENNA POLARITY & TEST DISTANCE: VERTICAL AT 3 M								
NO.	FREQ. (MHz)	EMISSION LEVEL (dBuV/m)	LIMIT (dBuV/m)	MARGIN (dB)	ANTENNA HEIGHT (m)	TABLE ANGLE (Degree)	RAW VALUE (dBuV)	CORRECTION FACTOR (dB/m)
1	*5320.00	106.5 PK			1.03 V	350	68.10	38.40
2	*5320.00	95.5 AV			1.03 V	350	57.10	38.40
3	5350.00	70.4 PK	74.0	-3.6	1.03 V	350	31.90	38.50
4	5350.00	51.1 AV	54.0	-2.9	1.03 V	350	12.60	38.50
5	10640.00	56.1 PK	74.0	-17.9	1.32 V	53	7.60	48.50
6	10640.00	42.4 AV	54.0	-11.6	1.32 V	53	-6.10	48.50

**REMARKS:**

1. Emission level (dBuV/m) = Raw Value (dBuV) + Correction Factor (dB/m).
2. Correction Factor (dB/m) = Antenna Factor (dB/m) + Cable Factor (dB).
3. The other emission levels were very low against the limit.
4. Margin value = Emission level – Limit value.
5. “ \* “: Fundamental frequency.



A D T

EUT TEST CONDITION		MEASUREMENT DETAIL	
CHANNEL	Channel 100	FREQUENCY RANGE	1 ~ 40GHz
INPUT POWER	120Vac, 60 Hz	DETECTOR FUNCTION	Peak (PK) Average (AV)
ENVIRONMENTAL CONDITIONS	25deg. C, 68%RH	TESTED BY	Anderson Hong

ANTENNA POLARITY & TEST DISTANCE: HORIZONTAL AT 3 M								
NO.	FREQ. (MHz)	EMISSION LEVEL (dBuV/m)	LIMIT (dBuV/m)	MARGIN (dB)	ANTENNA HEIGHT (m)	TABLE ANGLE (Degree)	RAW VALUE (dBuV)	CORRECTION FACTOR (dB/m)
1	5460.00	58.7 PK	74.0	-15.3	1.16 H	360	20.00	38.70
2	5460.00	43.1 AV	54.0	-10.9	1.16 H	360	4.40	38.70
3	#5470.00	62.8 PK	68.3	-5.5	1.16 H	360	24.10	38.70
4	*5500.00	104.5 PK			1.06 H	21	65.80	38.70
5	*5500.00	93.5 AV			1.06 H	21	54.80	38.70
6	11000.00	56.2 PK	74.0	-17.8	1.12 H	74	7.00	49.20
7	11000.00	42.7 AV	54.0	-11.3	1.12 H	74	-6.50	49.20
ANTENNA POLARITY & TEST DISTANCE: VERTICAL AT 3 M								
NO.	FREQ. (MHz)	EMISSION LEVEL (dBuV/m)	LIMIT (dBuV/m)	MARGIN (dB)	ANTENNA HEIGHT (m)	TABLE ANGLE (Degree)	RAW VALUE (dBuV)	CORRECTION FACTOR (dB/m)
1	5460.00	61.9 PK	74.0	-12.1	1.00 V	360	23.20	38.70
2	5460.00	45.8 AV	54.0	-8.2	1.00 V	360	7.10	38.70
3	#5470.00	67.1 PK	68.3	-1.2	1.00 V	360	28.40	38.70
4	*5500.00	109.6 PK			1.00 V	14	70.90	38.70
5	*5500.00	98.2 AV			1.00 V	14	59.50	38.70
6	11000.00	54.2 PK	74.0	-19.8	1.05 V	120	5.00	49.20
7	11000.00	42.7 AV	54.0	-11.3	1.05 V	120	-6.50	49.20

**REMARKS:**

1. Emission level (dBuV/m) = Raw Value (dBuV) + Correction Factor (dB/m).
2. Correction Factor (dB/m) = Antenna Factor (dB/m) + Cable Factor (dB).
3. The other emission levels were very low against the limit.
4. Margin value = Emission level – Limit value.
5. “ \* “: Fundamental frequency.
6. “#”:The radiated frequency is out the restricted band.



A D T

EUT TEST CONDITION		MEASUREMENT DETAIL	
CHANNEL	Channel 116	FREQUENCY RANGE	1 ~ 40GHz
INPUT POWER	120Vac, 60 Hz	DETECTOR FUNCTION	Peak (PK) Average (AV)
ENVIRONMENTAL CONDITIONS	25deg. C, 68%RH	TESTED BY	Anderson Hong

ANTENNA POLARITY & TEST DISTANCE: HORIZONTAL AT 3 M								
NO.	FREQ. (MHz)	EMISSION LEVEL (dBuV/m)	LIMIT (dBuV/m)	MARGIN (dB)	ANTENNA HEIGHT (m)	TABLE ANGLE (Degree)	RAW VALUE (dBuV)	CORRECTION FACTOR (dB/m)
1	*5580.00	103.7 PK			1.04 H	360	64.80	38.90
2	*5580.00	92.7 AV			1.04 H	360	53.80	38.90
3	11160.00	56.4 PK	74.0	-17.6	1.13 H	307	7.10	49.30
4	11160.00	42.8 AV	54.0	-11.2	1.13 H	307	-6.50	49.30
5	#16740.00	61.7 PK	68.3	-6.6	1.07 H	345	10.20	51.50
ANTENNA POLARITY & TEST DISTANCE: VERTICAL AT 3 M								
NO.	FREQ. (MHz)	EMISSION LEVEL (dBuV/m)	LIMIT (dBuV/m)	MARGIN (dB)	ANTENNA HEIGHT (m)	TABLE ANGLE (Degree)	RAW VALUE (dBuV)	CORRECTION FACTOR (dB/m)
1	*5580.00	110.5 PK			1.00 V	360	71.60	38.90
2	*5580.00	99.6 AV			1.00 V	360	60.70	38.90
3	11160.00	56.3 PK	74.0	-17.7	1.07 V	214	7.00	49.30
4	11160.00	42.6 AV	54.0	-11.4	1.07 V	214	-6.70	49.30
5	#16740.00	60.6 PK	68.3	-7.7	1.03 V	248	9.10	51.50

**REMARKS:**

1. Emission level (dBuV/m) = Raw Value (dBuV) + Correction Factor (dB/m).
2. Correction Factor (dB/m) = Antenna Factor (dB/m) + Cable Factor (dB).
3. The other emission levels were very low against the limit.
4. Margin value = Emission level – Limit value.
5. “ \* “: Fundamental frequency.
6. “#”:The radiated frequency is out the restricted band.



A D T

EUT TEST CONDITION		MEASUREMENT DETAIL	
CHANNEL	Channel 140	FREQUENCY RANGE	1 ~ 40GHz
INPUT POWER	120Vac, 60 Hz	DETECTOR FUNCTION	Peak (PK) Average (AV)
ENVIRONMENTAL CONDITIONS	25deg. C, 68%RH	TESTED BY	Anderson Hong

ANTENNA POLARITY & TEST DISTANCE: HORIZONTAL AT 3 M								
NO.	FREQ. (MHz)	EMISSION LEVEL (dBuV/m)	LIMIT (dBuV/m)	MARGIN (dB)	ANTENNA HEIGHT (m)	TABLE ANGLE (Degree)	RAW VALUE (dBuV)	CORRECTION FACTOR (dB/m)
1	*5700.00	102.2 PK			1.12 H	360	63.00	39.20
2	*5700.00	91.3 AV			1.12 H	360	52.10	39.20
3	#5725.00	64.2 PK	68.3	-4.1	1.26 H	78	25.00	39.20
4	11400.00	55.4 PK	74.0	-18.6	1.42 H	289	6.10	49.30
5	11400.00	42.5 AV	54.0	-11.5	1.42 H	289	-6.80	49.30
ANTENNA POLARITY & TEST DISTANCE: VERTICAL AT 3 M								
NO.	FREQ. (MHz)	EMISSION LEVEL (dBuV/m)	LIMIT (dBuV/m)	MARGIN (dB)	ANTENNA HEIGHT (m)	TABLE ANGLE (Degree)	RAW VALUE (dBuV)	CORRECTION FACTOR (dB/m)
1	*5700.00	108.5 PK			1.17 V	360	69.30	39.20
2	*5700.00	97.4 AV			1.17 V	360	58.20	39.20
3	#5725.00	66.6 PK	68.3	-1.7	1.11 V	72	27.40	39.20
4	11400.00	52.9 PK	74.0	-21.1	1.43 V	107	3.60	49.30
5	11400.00	42.6 AV	54.0	-11.4	1.43 V	107	-6.70	49.30

**REMARKS:**

1. Emission level (dBuV/m) = Raw Value (dBuV) + Correction Factor (dB/m).
2. Correction Factor (dB/m) = Antenna Factor (dB/m) + Cable Factor (dB).
3. The other emission levels were very low against the limit.
4. Margin value = Emission level – Limit value.
5. “ \* “: Fundamental frequency.
6. “#”:The radiated frequency is out the restricted band.



**BELOW 1GHz WORST-CASE DATA : 802.11a**

EUT TEST CONDITION		MEASUREMENT DETAIL	
CHANNEL	Channel 64	FREQUENCY RANGE	Below 1000MHz
INPUT POWER	120Vac, 60 Hz	DETECTOR FUNCTION	Quasi-Peak
ENVIRONMENTAL CONDITIONS	25deg. C, 68%RH	TESTED BY	Anderson Hong
TEST MODE	A1 (With MSR& Main Ant.)		

ANTENNA POLARITY & TEST DISTANCE: HORIZONTAL AT 3 M								
NO.	FREQ. (MHz)	EMISSION LEVEL (dBuV/m)	LIMIT (dBuV/m)	MARGIN (dB)	ANTENNA HEIGHT (m)	TABLE ANGLE (Degree)	RAW VALUE (dBuV)	CORRECTION FACTOR (dB/m)
1	78.50	23.3 QP	40.0	-16.7	2.00 H	3	13.00	10.30
2	123.12	20.6 QP	43.5	-22.9	1.50 H	75	8.50	12.10
3	189.08	22.6 QP	43.5	-20.9	1.50 H	61	10.60	12.00
4	222.06	22.7 QP	46.0	-23.3	1.50 H	18	10.70	12.00
5	297.72	21.6 QP	46.0	-24.4	1.25 H	283	6.80	14.80
6	544.10	26.8 QP	46.0	-19.2	2.00 H	3	5.70	21.10
ANTENNA POLARITY & TEST DISTANCE: VERTICAL AT 3 M								
NO.	FREQ. (MHz)	EMISSION LEVEL (dBuV/m)	LIMIT (dBuV/m)	MARGIN (dB)	ANTENNA HEIGHT (m)	TABLE ANGLE (Degree)	RAW VALUE (dBuV)	CORRECTION FACTOR (dB/m)
1	78.50	21.6 QP	40.0	-18.4	1.50 V	55	11.30	10.30
2	107.60	21.2 QP	43.5	-22.3	1.50 V	246	10.80	10.40
3	134.76	20.7 QP	43.5	-22.8	1.50 V	91	7.60	13.10
4	189.08	27.5 QP	43.5	-16.0	1.00 V	54	15.50	12.00
5	243.40	23.7 QP	46.0	-22.3	1.00 V	26	10.90	12.80
6	297.72	22.4 QP	46.0	-23.6	1.00 V	317	7.60	14.80

**REMARKS:**

1. Emission level (dBuV/m) = Raw Value (dBuV) + Correction Factor (dB/m).
2. Correction Factor (dB/m) = Antenna Factor (dB/m) + Cable Factor (dB).
3. The other emission levels were very low against the limit.
4. Margin value = Emission level – Limit value.



A D T

EUT TEST CONDITION		MEASUREMENT DETAIL	
CHANNEL	Channel 64	FREQUENCY RANGE	Below 1000MHz
INPUT POWER (SYSTEM)	120Vac, 60 Hz	DETECTOR FUNCTION	Quasi-Peak
ENVIRONMENTAL CONDITIONS	25deg. C, 68%RH	TESTED BY	Anderson Hong
TEST MODE	A2 (With MSR & Main Ant.)		

ANTENNA POLARITY & TEST DISTANCE: HORIZONTAL AT 3 M								
NO.	FREQ. (MHz)	EMISSION LEVEL (dBuV/m)	LIMIT (dBuV/m)	MARGIN (dB)	ANTENNA HEIGHT (m)	TABLE ANGLE (Degree)	RAW VALUE (dBuV)	CORRECTION FACTOR (dB/m)
1	134.76	33.5 QP	43.5	-10.0	1.25 H	101	20.40	13.10
2	225.94	32.1 QP	46.0	-13.9	1.00 H	17	19.90	12.20
3	336.52	27.7 QP	46.0	-18.3	1.00 H	48	11.90	15.80
4	431.58	27.5 QP	46.0	-18.5	1.50 H	90	9.20	18.30
5	544.10	27.2 QP	46.0	-18.8	1.00 H	110	6.10	21.10
6	664.38	29.8 QP	46.0	-16.2	1.00 H	66	7.10	22.70
ANTENNA POLARITY & TEST DISTANCE: VERTICAL AT 3 M								
NO.	FREQ. (MHz)	EMISSION LEVEL (dBuV/m)	LIMIT (dBuV/m)	MARGIN (dB)	ANTENNA HEIGHT (m)	TABLE ANGLE (Degree)	RAW VALUE (dBuV)	CORRECTION FACTOR (dB/m)
1	138.64	27.3 QP	43.5	-16.2	1.50 V	0	13.80	13.50
2	165.80	27.0 QP	43.5	-16.5	1.00 V	127	13.30	13.70
3	189.08	28.3 QP	43.5	-15.2	1.00 V	26	16.30	12.00
4	224.00	25.7 QP	46.0	-20.3	1.25 V	321	13.60	12.10
5	431.58	27.8 QP	46.0	-18.2	1.25 V	145	9.50	18.30
6	664.38	26.7 QP	46.0	-19.3	1.25 V	113	4.00	22.70

**REMARKS:**

1. Emission level (dBuV/m) = Raw Value (dBuV) + Correction Factor (dB/m).
2. Correction Factor (dB/m) = Antenna Factor (dB/m) + Cable Factor (dB).
3. The other emission levels were very low against the limit.
4. Margin value = Emission level – Limit value.



A D T

EUT TEST CONDITION		MEASUREMENT DETAIL	
CHANNEL	Channel 64	FREQUENCY RANGE	Below 1000MHz
INPUT POWER	120Vac, 60 Hz	DETECTOR FUNCTION	Quasi-Peak
ENVIRONMENTAL CONDITIONS	25deg. C, 68%RH	TESTED BY	Anderson Hong
TEST MODE	B1 (Without MSR & Main Ant.)		

ANTENNA POLARITY & TEST DISTANCE: HORIZONTAL AT 3 M								
NO.	FREQ. (MHz)	EMISSION LEVEL (dBuV/m)	LIMIT (dBuV/m)	MARGIN (dB)	ANTENNA HEIGHT (m)	TABLE ANGLE (Degree)	RAW VALUE (dBuV)	CORRECTION FACTOR (dB/m)
1	72.68	20.4 QP	40.0	-19.6	1.00 H	325	8.70	11.70
2	117.30	17.9 QP	43.5	-25.6	1.25 H	17	6.30	11.60
3	189.08	21.3 QP	43.5	-22.2	1.25 H	58	9.30	12.00
4	224.00	22.4 QP	46.0	-23.6	1.00 H	25	10.30	12.10
5	515.00	24.9 QP	46.0	-21.1	1.25 H	17	4.40	20.50
6	544.10	27.3 QP	46.0	-18.7	1.00 H	5	6.20	21.10
ANTENNA POLARITY & TEST DISTANCE: VERTICAL AT 3 M								
NO.	FREQ. (MHz)	EMISSION LEVEL (dBuV/m)	LIMIT (dBuV/m)	MARGIN (dB)	ANTENNA HEIGHT (m)	TABLE ANGLE (Degree)	RAW VALUE (dBuV)	CORRECTION FACTOR (dB/m)
1	70.74	25.2 QP	40.0	-14.8	1.00 V	75	13.00	12.20
2	107.60	21.9 QP	43.5	-21.6	1.00 V	139	11.50	10.40
3	189.08	28.4 QP	43.5	-15.1	1.00 V	10	16.40	12.00
4	216.24	20.9 QP	46.0	-25.1	1.00 V	260	9.10	11.80
5	243.40	22.2 QP	46.0	-23.8	1.00 V	316	9.40	12.80
6	297.72	22.4 QP	46.0	-23.6	1.00 V	46	7.60	14.80

**REMARKS:**

1. Emission level (dBuV/m) = Raw Value (dBuV) + Correction Factor (dB/m).
2. Correction Factor (dB/m) = Antenna Factor (dB/m) + Cable Factor (dB).
3. The other emission levels were very low against the limit.
4. Margin value = Emission level – Limit value.



A D T

EUT TEST CONDITION		MEASUREMENT DETAIL	
CHANNEL	Channel 64	FREQUENCY RANGE	Below 1000MHz
INPUT POWER (SYSTEM)	120Vac, 60 Hz	DETECTOR FUNCTION	Quasi-Peak
ENVIRONMENTAL CONDITIONS	25deg. C, 68%RH	TESTED BY	Anderson Hong
TEST MODE	B2 (Without MSR & Main Ant.)		

ANTENNA POLARITY & TEST DISTANCE: HORIZONTAL AT 3 M								
NO.	FREQ. (MHz)	EMISSION LEVEL (dBuV/m)	LIMIT (dBuV/m)	MARGIN (dB)	ANTENNA HEIGHT (m)	TABLE ANGLE (Degree)	RAW VALUE (dBuV)	CORRECTION FACTOR (dB/m)
1	130.88	33.7 QP	43.5	-9.8	1.00 H	63	20.90	12.80
2	220.12	31.7 QP	46.0	-14.3	1.00 H	180	19.70	12.00
3	299.66	27.8 QP	46.0	-18.2	1.00 H	136	12.90	14.90
4	336.52	29.6 QP	46.0	-16.4	1.25 H	88	13.80	15.80
5	365.62	26.7 QP	46.0	-19.3	1.00 H	143	10.10	16.60
6	431.58	26.3 QP	46.0	-19.7	1.25 H	3	8.00	18.30
ANTENNA POLARITY & TEST DISTANCE: VERTICAL AT 3 M								
NO.	FREQ. (MHz)	EMISSION LEVEL (dBuV/m)	LIMIT (dBuV/m)	MARGIN (dB)	ANTENNA HEIGHT (m)	TABLE ANGLE (Degree)	RAW VALUE (dBuV)	CORRECTION FACTOR (dB/m)
1	189.08	28.2 QP	43.5	-15.3	1.25 V	10	16.20	12.00
2	231.76	26.0 QP	46.0	-20.0	1.00 V	210	13.60	12.40
3	299.66	25.9 QP	46.0	-20.1	1.25 V	103	11.00	14.90
4	336.52	28.8 QP	46.0	-17.2	1.25 V	90	13.00	15.80
5	365.62	26.4 QP	46.0	-19.6	1.00 V	81	9.80	16.60
6	431.58	30.8 QP	46.0	-15.2	1.25 V	156	12.50	18.30

**REMARKS:**

1. Emission level (dBuV/m) = Raw Value (dBuV) + Correction Factor (dB/m).
2. Correction Factor (dB/m) = Antenna Factor (dB/m) + Cable Factor (dB).
3. The other emission levels were very low against the limit.
4. Margin value = Emission level – Limit value.



A D T

EUT TEST CONDITION		MEASUREMENT DETAIL	
CHANNEL	Channel 64	FREQUENCY RANGE	Below 1000MHz
INPUT POWER	120Vac, 60 Hz	DETECTOR FUNCTION	Quasi-Peak
ENVIRONMENTAL CONDITIONS	25deg. C, 65%RH	TESTED BY	Anderson Hong
TEST MODE	C1 (Without MSR & Aux Ant.)		

ANTENNA POLARITY & TEST DISTANCE: HORIZONTAL AT 3 M								
NO.	FREQ. (MHz)	EMISSION LEVEL (dBuV/m)	LIMIT (dBuV/m)	MARGIN (dB)	ANTENNA HEIGHT (m)	TABLE ANGLE (Degree)	RAW VALUE (dBuV)	CORRECTION FACTOR (dB/m)
1	125.06	21.6 QP	43.5	-21.9	1.50 H	164	9.30	12.30
2	159.98	22.0 QP	43.5	-21.5	1.50 H	311	8.00	14.00
3	189.08	22.1 QP	43.5	-21.4	1.50 H	98	10.10	12.00
4	297.72	20.9 QP	46.0	-25.1	2.00 H	124	6.10	14.80
5	515.00	24.2 QP	46.0	-21.8	2.00 H	313	3.70	20.50
6	544.10	26.8 QP	46.0	-19.2	1.00 H	31	5.70	21.10
ANTENNA POLARITY & TEST DISTANCE: VERTICAL AT 3 M								
NO.	FREQ. (MHz)	EMISSION LEVEL (dBuV/m)	LIMIT (dBuV/m)	MARGIN (dB)	ANTENNA HEIGHT (m)	TABLE ANGLE (Degree)	RAW VALUE (dBuV)	CORRECTION FACTOR (dB/m)
1	84.32	21.6 QP	40.0	-18.4	1.00 V	84	12.40	9.20
2	107.60	20.9 QP	43.5	-22.6	1.00 V	244	10.50	10.40
3	189.08	28.5 QP	43.5	-15.0	1.00 V	27	16.50	12.00
4	216.24	21.1 QP	46.0	-24.9	1.00 V	34	9.30	11.80
5	243.40	23.8 QP	46.0	-22.2	1.00 V	242	11.00	12.80
6	297.72	23.1 QP	46.0	-22.9	1.00 V	282	8.30	14.80

**REMARKS:**

1. Emission level (dBuV/m) = Raw Value (dBuV) + Correction Factor (dB/m).
2. Correction Factor (dB/m) = Antenna Factor (dB/m) + Cable Factor (dB).
3. The other emission levels were very low against the limit.
4. Margin value = Emission level – Limit value.



A D T

EUT TEST CONDITION		MEASUREMENT DETAIL	
CHANNEL	Channel 64	FREQUENCY RANGE	Below 1000MHz
INPUT POWER (SYSTEM)	120Vac, 60 Hz	DETECTOR FUNCTION	Quasi-Peak
ENVIRONMENTAL CONDITIONS	25deg. C, 65%RH	TESTED BY	Anderson Hong
TEST MODE	C2 (Without MSR & Aux Ant.)		

ANTENNA POLARITY & TEST DISTANCE: HORIZONTAL AT 3 M								
NO.	FREQ. (MHz)	EMISSION LEVEL (dBuV/m)	LIMIT (dBuV/m)	MARGIN (dB)	ANTENNA HEIGHT (m)	TABLE ANGLE (Degree)	RAW VALUE (dBuV)	CORRECTION FACTOR (dB/m)
1	144.46	34.6 QP	43.5	-8.9	1.00 H	84	20.90	13.70
2	165.80	31.9 QP	43.5	-11.6	1.25 H	115	18.20	13.70
3	198.78	30.4 QP	43.5	-13.1	1.00 H	17	19.10	11.30
4	299.66	27.9 QP	46.0	-18.1	1.00 H	17	13.00	14.90
5	336.52	30.7 QP	46.0	-15.3	1.00 H	93	14.90	15.80
6	499.48	30.7 QP	46.0	-15.3	1.25 H	72	10.60	20.10
ANTENNA POLARITY & TEST DISTANCE: VERTICAL AT 3 M								
NO.	FREQ. (MHz)	EMISSION LEVEL (dBuV/m)	LIMIT (dBuV/m)	MARGIN (dB)	ANTENNA HEIGHT (m)	TABLE ANGLE (Degree)	RAW VALUE (dBuV)	CORRECTION FACTOR (dB/m)
1	142.52	29.5 QP	43.5	-14.0	1.25 V	337	15.80	13.70
2	189.08	27.4 QP	43.5	-16.1	1.00 V	154	15.40	12.00
3	231.76	23.6 QP	46.0	-22.4	1.00 V	237	11.20	12.40
4	336.52	29.7 QP	46.0	-16.3	1.25 V	130	13.90	15.80
5	431.58	31.6 QP	46.0	-14.4	1.00 V	132	13.30	18.30
6	499.48	28.4 QP	46.0	-17.6	1.25 V	17	8.30	20.10

**REMARKS:**

1. Emission level (dBuV/m) = Raw Value (dBuV) + Correction Factor (dB/m).
2. Correction Factor (dB/m) = Antenna Factor (dB/m) + Cable Factor (dB).
3. The other emission levels were very low against the limit.
4. Margin value = Emission level – Limit value.



A D T

EUT TEST CONDITION		MEASUREMENT DETAIL	
CHANNEL	Channel 116	FREQUENCY RANGE	Below 1000MHz
INPUT POWER	120Vac, 60 Hz	DETECTOR FUNCTION	Quasi-Peak
ENVIRONMENTAL CONDITIONS	25deg. C, 68%RH	TESTED BY	Anderson Hong
TEST MODE	A1 (With MSR & Main Ant.)		

ANTENNA POLARITY & TEST DISTANCE: HORIZONTAL AT 3 M								
NO.	FREQ. (MHz)	EMISSION LEVEL (dBuV/m)	LIMIT (dBuV/m)	MARGIN (dB)	ANTENNA HEIGHT (m)	TABLE ANGLE (Degree)	RAW VALUE (dBuV)	CORRECTION FACTOR (dB/m)
1	80.44	23.8 QP	40.0	-16.2	2.00 H	339	14.00	9.80
2	189.08	22.1 QP	43.5	-21.4	1.50 H	54	10.10	12.00
3	222.06	23.4 QP	46.0	-22.6	1.50 H	18	11.40	12.00
4	297.72	20.8 QP	46.0	-25.2	2.00 H	238	6.00	14.80
5	515.00	25.4 QP	46.0	-20.6	2.00 H	299	4.90	20.50
6	544.10	27.2 QP	46.0	-18.8	1.00 H	275	6.10	21.10
ANTENNA POLARITY & TEST DISTANCE: VERTICAL AT 3 M								
NO.	FREQ. (MHz)	EMISSION LEVEL (dBuV/m)	LIMIT (dBuV/m)	MARGIN (dB)	ANTENNA HEIGHT (m)	TABLE ANGLE (Degree)	RAW VALUE (dBuV)	CORRECTION FACTOR (dB/m)
1	76.56	21.9 QP	40.0	-18.1	2.00 V	79	11.10	10.80
2	107.60	21.2 QP	43.5	-22.3	1.00 V	20	10.80	10.40
3	134.76	20.4 QP	43.5	-23.1	1.25 V	97	7.30	13.10
4	189.08	28.8 QP	43.5	-14.7	1.00 V	44	16.80	12.00
5	216.24	21.4 QP	46.0	-24.6	1.00 V	130	9.60	11.80
6	243.40	22.2 QP	46.0	-23.8	1.00 V	32	9.40	12.80

**REMARKS:**

1. Emission level (dBuV/m) = Raw Value (dBuV) + Correction Factor (dB/m).
2. Correction Factor (dB/m) = Antenna Factor (dB/m) + Cable Factor (dB).
3. The other emission levels were very low against the limit.
4. Margin value = Emission level – Limit value.



A D T

EUT TEST CONDITION		MEASUREMENT DETAIL	
CHANNEL	Channel 116	FREQUENCY RANGE	Below 1000MHz
INPUT POWER (SYSTEM)	120Vac, 60 Hz	DETECTOR FUNCTION	Quasi-Peak
ENVIRONMENTAL CONDITIONS	25deg. C, 68%RH	TESTED BY	Anderson Hong
TEST MODE	A2 (With MSR & Main Ant.)		

ANTENNA POLARITY & TEST DISTANCE: HORIZONTAL AT 3 M								
NO.	FREQ. (MHz)	EMISSION LEVEL (dBuV/m)	LIMIT (dBuV/m)	MARGIN (dB)	ANTENNA HEIGHT (m)	TABLE ANGLE (Degree)	RAW VALUE (dBuV)	CORRECTION FACTOR (dB/m)
1	136.70	35.7 QP	43.5	-7.8	1.50 H	82	22.40	13.30
2	225.94	33.4 QP	46.0	-12.6	1.25 H	169	21.20	12.20
3	336.52	27.7 QP	46.0	-18.3	1.00 H	44	11.90	15.80
4	431.58	27.4 QP	46.0	-18.6	2.00 H	63	9.10	18.30
5	544.10	26.9 QP	46.0	-19.1	2.00 H	7	5.80	21.10
6	666.32	30.3 QP	46.0	-15.7	1.00 H	57	7.60	22.70
ANTENNA POLARITY & TEST DISTANCE: VERTICAL AT 3 M								
NO.	FREQ. (MHz)	EMISSION LEVEL (dBuV/m)	LIMIT (dBuV/m)	MARGIN (dB)	ANTENNA HEIGHT (m)	TABLE ANGLE (Degree)	RAW VALUE (dBuV)	CORRECTION FACTOR (dB/m)
1	132.82	26.2 QP	43.5	-17.3	1.50 V	38	13.20	13.00
2	165.80	26.5 QP	43.5	-17.0	1.00 V	150	12.80	13.70
3	189.08	28.0 QP	43.5	-15.5	1.00 V	330	16.00	12.00
4	243.40	24.1 QP	46.0	-21.9	1.00 V	172	11.30	12.80
5	431.58	28.4 QP	46.0	-17.6	1.00 V	122	10.10	18.30
6	664.38	26.9 QP	46.0	-19.1	2.00 V	216	4.20	22.70

**REMARKS:**

1. Emission level (dBuV/m) = Raw Value (dBuV) + Correction Factor (dB/m).
2. Correction Factor (dB/m) = Antenna Factor (dB/m) + Cable Factor (dB).
3. The other emission levels were very low against the limit.
4. Margin value = Emission level – Limit value.





A D T

EUT TEST CONDITION		MEASUREMENT DETAIL	
CHANNEL	Channel 116	FREQUENCY RANGE	Below 1000MHz
INPUT POWER	120Vac, 60 Hz	DETECTOR FUNCTION	Quasi-Peak
ENVIRONMENTAL CONDITIONS	25deg. C, 68%RH	TESTED BY	Anderson Hong
TEST MODE	B1 (Without MSR & Main Ant.)		

ANTENNA POLARITY & TEST DISTANCE: HORIZONTAL AT 3 M								
NO.	FREQ. (MHz)	EMISSION LEVEL (dBuV/m)	LIMIT (dBuV/m)	MARGIN (dB)	ANTENNA HEIGHT (m)	TABLE ANGLE (Degree)	RAW VALUE (dBuV)	CORRECTION FACTOR (dB/m)
1	70.74	20.3 QP	40.0	-19.7	1.25 H	341	8.10	12.20
2	189.08	21.2 QP	43.5	-22.3	1.25 H	61	9.20	12.00
3	222.06	22.8 QP	46.0	-23.2	1.25 H	27	10.80	12.00
4	297.72	21.6 QP	46.0	-24.4	1.50 H	9	6.80	14.80
5	515.00	24.6 QP	46.0	-21.4	1.25 H	18	4.10	20.50
6	544.10	27.3 QP	46.0	-18.7	1.00 H	241	6.20	21.10
ANTENNA POLARITY & TEST DISTANCE: VERTICAL AT 3 M								
NO.	FREQ. (MHz)	EMISSION LEVEL (dBuV/m)	LIMIT (dBuV/m)	MARGIN (dB)	ANTENNA HEIGHT (m)	TABLE ANGLE (Degree)	RAW VALUE (dBuV)	CORRECTION FACTOR (dB/m)
1	70.74	26.6 QP	40.0	-13.4	1.00 V	86	14.40	12.20
2	107.60	21.5 QP	43.5	-22.0	1.00 V	195	11.10	10.40
3	189.08	27.7 QP	43.5	-15.8	1.00 V	249	15.70	12.00
4	216.24	22.6 QP	46.0	-23.4	1.00 V	271	10.80	11.80
5	243.40	21.7 QP	46.0	-24.3	1.00 V	59	8.90	12.80
6	297.72	22.4 QP	46.0	-23.6	1.00 V	144	7.60	14.80

**REMARKS:**

1. Emission level (dBuV/m) = Raw Value (dBuV) + Correction Factor (dB/m).
2. Correction Factor (dB/m) = Antenna Factor (dB/m) + Cable Factor (dB).
3. The other emission levels were very low against the limit.
4. Margin value = Emission level – Limit value.



A D T

EUT TEST CONDITION		MEASUREMENT DETAIL	
CHANNEL	Channel 116	FREQUENCY RANGE	Below 1000MHz
INPUT POWER (SYSTEM)	120Vac, 60 Hz	DETECTOR FUNCTION	Quasi-Peak
ENVIRONMENTAL CONDITIONS	25deg. C, 68%RH	TESTED BY	Anderson Hong
TEST MODE	B2 (Without MSR & Main Ant.)		

ANTENNA POLARITY & TEST DISTANCE: HORIZONTAL AT 3 M								
NO.	FREQ. (MHz)	EMISSION LEVEL (dBuV/m)	LIMIT (dBuV/m)	MARGIN (dB)	ANTENNA HEIGHT (m)	TABLE ANGLE (Degree)	RAW VALUE (dBuV)	CORRECTION FACTOR (dB/m)
1	128.94	36.1 QP	43.5	-7.4	1.25 H	270	23.50	12.60
2	220.12	32.2 QP	46.0	-13.8	1.50 H	15	20.20	12.00
3	297.72	28.3 QP	46.0	-17.7	1.00 H	109	13.50	14.80
4	336.52	28.9 QP	46.0	-17.1	1.25 H	103	13.10	15.80
5	365.62	26.8 QP	46.0	-19.2	1.00 H	141	10.20	16.60
6	499.48	29.8 QP	46.0	-16.2	1.25 H	85	9.70	20.10
ANTENNA POLARITY & TEST DISTANCE: VERTICAL AT 3 M								
NO.	FREQ. (MHz)	EMISSION LEVEL (dBuV/m)	LIMIT (dBuV/m)	MARGIN (dB)	ANTENNA HEIGHT (m)	TABLE ANGLE (Degree)	RAW VALUE (dBuV)	CORRECTION FACTOR (dB/m)
1	130.88	25.2 QP	43.5	-18.3	1.00 V	67	12.40	12.80
2	189.08	28.5 QP	43.5	-15.0	1.00 V	216	16.50	12.00
3	233.70	25.8 QP	46.0	-20.2	1.00 V	97	13.40	12.40
4	336.52	28.6 QP	46.0	-17.4	1.25 V	76	12.80	15.80
5	365.62	27.2 QP	46.0	-18.8	1.25 V	72	10.60	16.60
6	431.58	31.3 QP	46.0	-14.7	1.00 V	153	13.00	18.30

**REMARKS:**

1. Emission level (dBuV/m) = Raw Value (dBuV) + Correction Factor (dB/m).
2. Correction Factor (dB/m) = Antenna Factor (dB/m) + Cable Factor (dB).
3. The other emission levels were very low against the limit.
4. Margin value = Emission level – Limit value.



A D T

EUT TEST CONDITION		MEASUREMENT DETAIL	
CHANNEL	Channel 116	FREQUENCY RANGE	Below 1000MHz
INPUT POWER	120Vac, 60 Hz	DETECTOR FUNCTION	Quasi-Peak
ENVIRONMENTAL CONDITIONS	25deg. C, 65%RH	TESTED BY	Anderson Hong
TEST MODE	C1 (Without MSR & Aux Ant.)		

ANTENNA POLARITY & TEST DISTANCE: HORIZONTAL AT 3 M								
NO.	FREQ. (MHz)	EMISSION LEVEL (dBuV/m)	LIMIT (dBuV/m)	MARGIN (dB)	ANTENNA HEIGHT (m)	TABLE ANGLE (Degree)	RAW VALUE (dBuV)	CORRECTION FACTOR (dB/m)
1	80.44	18.1 QP	40.0	-21.9	1.50 H	71	8.30	9.80
2	123.12	21.4 QP	43.5	-22.1	2.00 H	195	9.30	12.10
3	163.86	22.5 QP	43.5	-21.0	1.50 H	307	8.70	13.80
4	301.60	16.4 QP	46.0	-29.6	1.00 H	6	1.40	15.00
5	515.00	24.5 QP	46.0	-21.5	2.00 H	245	4.00	20.50
6	544.10	27.1 QP	46.0	-18.9	1.00 H	15	6.00	21.10
ANTENNA POLARITY & TEST DISTANCE: VERTICAL AT 3 M								
NO.	FREQ. (MHz)	EMISSION LEVEL (dBuV/m)	LIMIT (dBuV/m)	MARGIN (dB)	ANTENNA HEIGHT (m)	TABLE ANGLE (Degree)	RAW VALUE (dBuV)	CORRECTION FACTOR (dB/m)
1	80.44	21.8 QP	40.0	-18.2	1.00 V	89	12.00	9.80
2	107.60	22.3 QP	43.5	-21.2	1.00 V	17	11.90	10.40
3	189.08	28.2 QP	43.5	-15.3	1.00 V	17	16.20	12.00
4	216.24	21.1 QP	46.0	-24.9	1.00 V	274	9.30	11.80
5	243.40	23.0 QP	46.0	-23.0	1.00 V	17	10.20	12.80
6	297.72	22.5 QP	46.0	-23.5	1.00 V	2	7.70	14.80

**REMARKS:**

1. Emission level (dBuV/m) = Raw Value (dBuV) + Correction Factor (dB/m).
2. Correction Factor (dB/m) = Antenna Factor (dB/m) + Cable Factor (dB).
3. The other emission levels were very low against the limit.
4. Margin value = Emission level – Limit value.



A D T

EUT TEST CONDITION		MEASUREMENT DETAIL	
CHANNEL	Channel 116	FREQUENCY RANGE	Below 1000MHz
INPUT POWER (SYSTEM)	120Vac, 60 Hz	DETECTOR FUNCTION	Quasi-Peak
ENVIRONMENTAL CONDITIONS	25deg. C, 65%RH	TESTED BY	Anderson Hong
TEST MODE	C2 (Without MSR & Aux Ant.)		

ANTENNA POLARITY & TEST DISTANCE: HORIZONTAL AT 3 M								
NO.	FREQ. (MHz)	EMISSION LEVEL (dBuV/m)	LIMIT (dBuV/m)	MARGIN (dB)	ANTENNA HEIGHT (m)	TABLE ANGLE (Degree)	RAW VALUE (dBuV)	CORRECTION FACTOR (dB/m)
1	144.46	32.6 QP	43.5	-10.9	1.50 H	69	18.90	13.70
2	165.80	32.2 QP	43.5	-11.3	1.00 H	109	18.50	13.70
3	194.90	29.4 QP	43.5	-14.1	1.00 H	9	17.80	11.60
4	336.52	30.9 QP	46.0	-15.1	1.00 H	104	15.10	15.80
5	431.58	27.8 QP	46.0	-18.2	1.00 H	9	9.50	18.30
6	499.48	28.4 QP	46.0	-17.6	1.50 H	36	8.30	20.10
ANTENNA POLARITY & TEST DISTANCE: VERTICAL AT 3 M								
NO.	FREQ. (MHz)	EMISSION LEVEL (dBuV/m)	LIMIT (dBuV/m)	MARGIN (dB)	ANTENNA HEIGHT (m)	TABLE ANGLE (Degree)	RAW VALUE (dBuV)	CORRECTION FACTOR (dB/m)
1	144.46	27.1 QP	43.5	-16.4	1.50 V	4	13.40	13.70
2	189.08	27.2 QP	43.5	-16.3	1.00 V	30	15.20	12.00
3	233.70	24.2 QP	46.0	-21.8	1.00 V	221	11.80	12.40
4	336.52	28.1 QP	46.0	-17.9	1.00 V	128	12.30	15.80
5	431.58	32.5 QP	46.0	-13.5	1.00 V	149	14.20	18.30
6	528.58	28.8 QP	46.0	-17.2	1.00 V	150	8.00	20.80

**REMARKS:**

1. Emission level (dBuV/m) = Raw Value (dBuV) + Correction Factor (dB/m).
2. Correction Factor (dB/m) = Antenna Factor (dB/m) + Cable Factor (dB).
3. The other emission levels were very low against the limit.
4. Margin value = Emission level – Limit value.

## 4.2 CONDUCTED EMISSION MEASUREMENT

### 4.2.1 LIMITS OF CONDUCTED EMISSION MEASUREMENT

FREQUENCY OF EMISSION (MHz)	CONDUCTED LIMIT (dB $\mu$ V)	
	Quasi-peak	Average
0.15 ~ 0.5	66 to 56	56 to 46
0.5 ~ 5	56	46
5 ~ 30	60	50

- NOTE:** 1. The lower limit shall apply at the transition frequencies.  
 2. The limit decreases in line with the logarithm of the frequency in the range of 0.15 to 0.50MHz.  
 3. All emanations from a class A/B digital device or system, including any network of conductors and apparatus connected thereto, shall not exceed the level of field strengths specified above.

### 4.2.2 TEST INSTRUMENTS

DESCRIPTION & MANUFACTURER	MODEL NO.	SERIAL NO.	DATE OF CALIBRATION	DUE DATE OF CALIBRATION
Test Receiver ROHDE & SCHWARZ	ESCS30	100289	Nov. 19, 2011	Nov. 18, 2012
RF signal cable Woken	5D-FB	Cable-HYCO2-01	Dec. 29, 2011	Dec. 28, 2012
LISN ROHDE & SCHWARZ (EUT)	ESH2-Z5	100100	Dec. 30, 2011	Dec. 29, 2012
LISN ROHDE & SCHWARZ (Peripheral)	ESH3-Z5	100311	Jul. 06, 2012	Jul. 05, 2013
Software ADT	BV ADT_Cond_ V7.3.7.3	NA	NA	NA

- NOTE:** 1. The calibration interval of the above test instruments is 12 months and the calibrations are traceable to NML/ROC and NIST/USA.  
 2. The test was performed in HwaYa Shielded Room 2.  
 3. The VCCI Site Registration No. is C-2047.

#### 4.2.3 TEST PROCEDURES

- a. The EUT was placed 0.4 meters from the conducting wall of the shielded room with EUT being connected to the power mains through a line impedance stabilization network (LISN). Other support units were connected to the power mains through another LISN. The two LISNs provide 50 ohm/ 50uH of coupling impedance for the measuring instrument.
- b. Both lines of the power mains connected to the EUT were checked for maximum conducted interference.
- c. The frequency range from 150kHz to 30MHz was searched. Emission levels under (Limit - 20dB) was not recorded.

**NOTE:** All modes of operation were investigated and the worst-case emissions are reported.

#### 4.2.4 DEVIATION FROM TEST STANDARD

No deviation.

#### 4.2.5 TEST SETUP

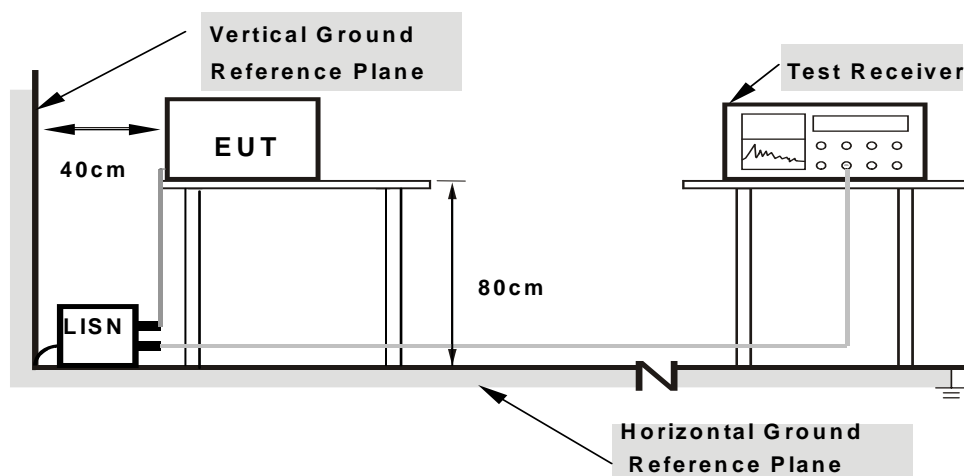

- Note:**
1. Support units were connected to second LISN.
  2. Both of LISNs (AMN) are 80 cm from EUT and at least 80 from other units and other metal planes

For the actual test configuration, please refer to the attached file (Test Setup Photo).

#### 4.2.6 EUT OPERATING CONDITIONS

Same as 4.1.6.

### 4.2.7 TEST RESULTS

#### CONDUCTED WORST-CASE DATA : 802.11a

PHASE	Line 1	6dB BANDWIDTH	9kHz
CHANNEL	Channel 64	TEST MODE	A1 (Without MSR & Aux Ant.)

No	Freq. [MHz]	Corr. Factor (dB)	Reading Value		Emission Level		Limit		Margin	
			[dB (uV)]		[dB (uV)]		[dB (uV)]		(dB)	
			Q.P.	AV.	Q.P.	AV.	Q.P.	AV.	Q.P.	AV.
1	0.15391	0.17	34.59	27.39	34.76	27.56	65.79	55.79	-31.03	-28.23
2	0.23203	0.17	39.51	29.58	39.68	29.75	62.38	52.38	-22.69	-22.62
3	0.27109	0.18	38.79	28.67	38.97	28.85	61.08	51.08	-22.11	-22.23
4	0.31016	0.19	41.11	37.98	41.30	38.17	59.97	49.97	-18.67	-11.80
5	0.96250	0.23	37.39	32.56	37.62	32.79	56.00	46.00	-18.38	-13.21
6	3.07031	0.35	33.08	24.51	33.43	24.86	56.00	46.00	-22.57	-21.14

- REMARKS:**
1. Q.P. and AV. are abbreviations of quasi-peak and average individually.
  2. The emission levels of other frequencies were very low against the limit.
  3. Margin value = Emission level - Limit value
  4. Correction factor = Insertion loss + Cable loss
  5. Emission Level = Correction Factor + Reading Value.

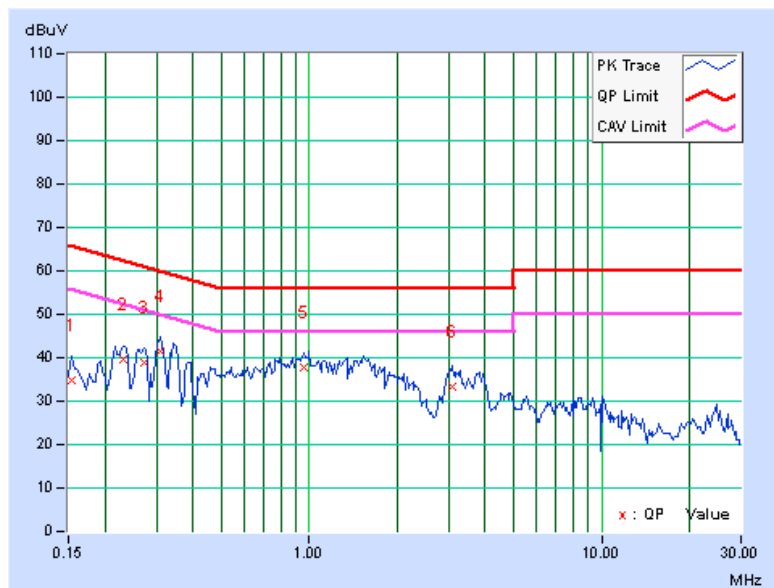



A D T

PHASE	Line 2	6dB BANDWIDTH	9kHz
CHANNEL	Channel 64	TEST MODE	A1 (Without MSR & Aux Ant.)

No	Freq. [MHz]	Corr. Factor (dB)	Reading Value		Emission Level		Limit		Margin	
			[dB (uV)]		[dB (uV)]		[dB (uV)]		(dB)	
			Q.P.	AV.	Q.P.	AV.	Q.P.	AV.	Q.P.	AV.
1	0.22812	0.15	39.65	31.56	39.80	31.71	62.52	52.52	-22.71	-20.80
2	0.31016	0.17	46.19	43.08	46.36	43.25	59.97	49.97	-13.61	-6.72
3	0.96250	0.19	40.81	34.38	41.00	34.57	56.00	46.00	-15.00	-11.43
4	1.19531	0.21	38.51	31.94	38.72	32.15	56.00	46.00	-17.28	-13.85
5	1.60938	0.24	39.31	32.72	39.55	32.96	56.00	46.00	-16.45	-13.04
6	3.00000	0.33	33.48	26.14	33.81	26.47	56.00	46.00	-22.19	-19.53

- REMARKS:**
1. Q.P. and AV. are abbreviations of quasi-peak and average individually.
  2. The emission levels of other frequencies were very low against the limit.
  3. Margin value = Emission level - Limit value
  4. Correction factor = Insertion loss + Cable loss
  5. Emission Level = Correction Factor + Reading Value.

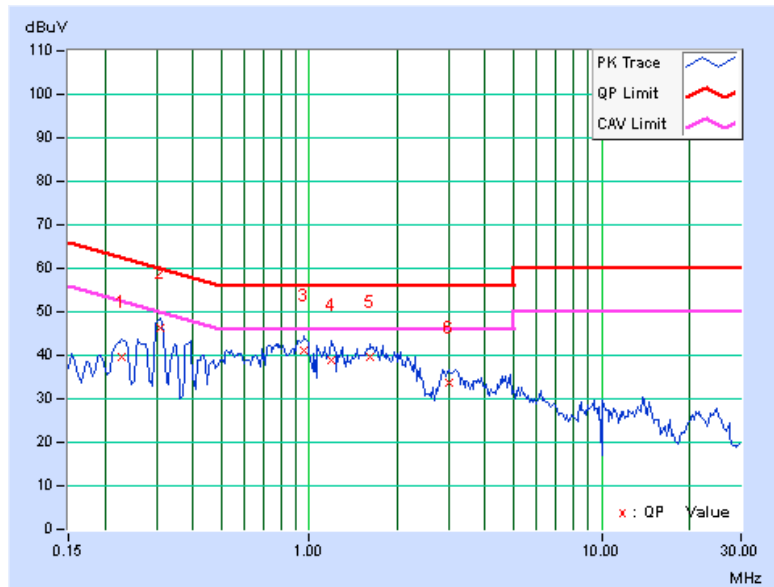



PHASE	Line 1	6dB BANDWIDTH	9kHz
CHANNEL	Channel 64	TEST MODE	A2 (Without MSR & Aux Ant.)

No	Freq. [MHz]	Corr. Factor (dB)	Reading Value		Emission Level		Limit		Margin	
			[dB (uV)]		[dB (uV)]		[dB (uV)]		(dB)	
			Q.P.	AV.	Q.P.	AV.	Q.P.	AV.	Q.P.	AV.
1	0.18125	0.17	46.86	35.02	47.03	35.19	64.43	54.43	-17.40	-19.24
2	0.24375	0.18	39.12	25.98	39.30	26.16	61.97	51.97	-22.67	-25.81
3	0.29063	0.18	34.00	21.69	34.18	21.87	60.51	50.51	-26.32	-28.63
4	0.42344	0.20	31.01	21.56	31.21	21.76	57.38	47.38	-26.17	-25.62
5	6.61719	0.43	31.32	23.17	31.75	23.60	60.00	50.00	-28.25	-26.40
6	10.68750	0.50	39.13	31.80	39.63	32.30	60.00	50.00	-20.37	-17.70

- REMARKS:**
1. Q.P. and AV. are abbreviations of quasi-peak and average individually.
  2. The emission levels of other frequencies were very low against the limit.
  3. Margin value = Emission level - Limit value
  4. Correction factor = Insertion loss + Cable loss
  5. Emission Level = Correction Factor + Reading Value.

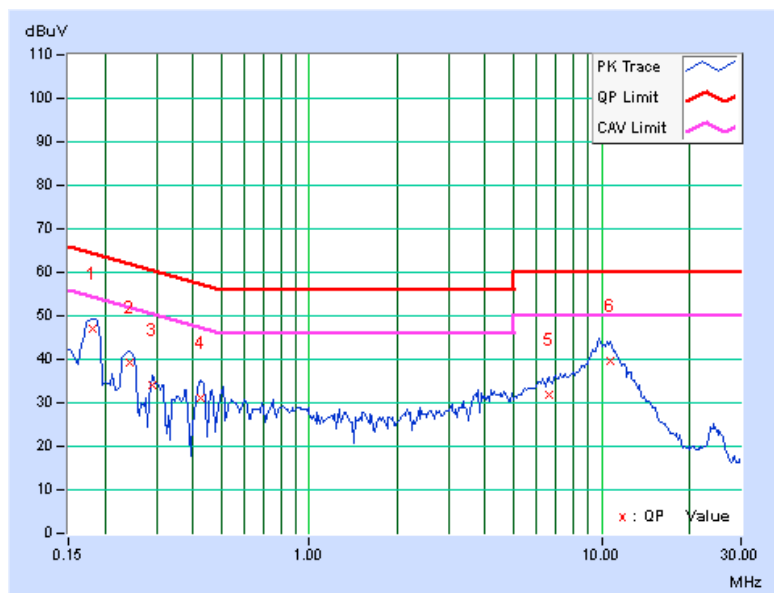



A D T

PHASE	Line 2	6dB BANDWIDTH	9kHz
CHANNEL	Channel 64	TEST MODE	A2 (Without MSR & Aux Ant.)

No	Freq. [MHz]	Corr. Factor (dB)	Reading Value		Emission Level		Limit		Margin	
			[dB (uV)]		[dB (uV)]		[dB (uV)]		(dB)	
			Q.P.	AV.	Q.P.	AV.	Q.P.	AV.	Q.P.	AV.
1	0.18125	0.16	47.16	36.06	47.32	36.22	64.43	54.43	-17.11	-18.21
2	0.24374	0.16	40.17	30.28	40.33	30.44	61.97	51.97	-21.64	-21.53
3	0.29453	0.16	36.06	28.19	36.22	28.35	60.40	50.40	-24.17	-22.04
4	0.43125	0.18	36.47	24.36	36.65	24.54	57.23	47.23	-20.58	-22.69
5	3.30469	0.34	31.29	22.02	31.63	22.36	56.00	46.00	-24.37	-23.64
6	10.39063	0.58	41.75	34.21	42.33	34.79	60.00	50.00	-17.67	-15.21

- REMARKS:**
1. Q.P. and AV. are abbreviations of quasi-peak and average individually.
  2. The emission levels of other frequencies were very low against the limit.
  3. Margin value = Emission level - Limit value
  4. Correction factor = Insertion loss + Cable loss
  5. Emission Level = Correction Factor + Reading Value.

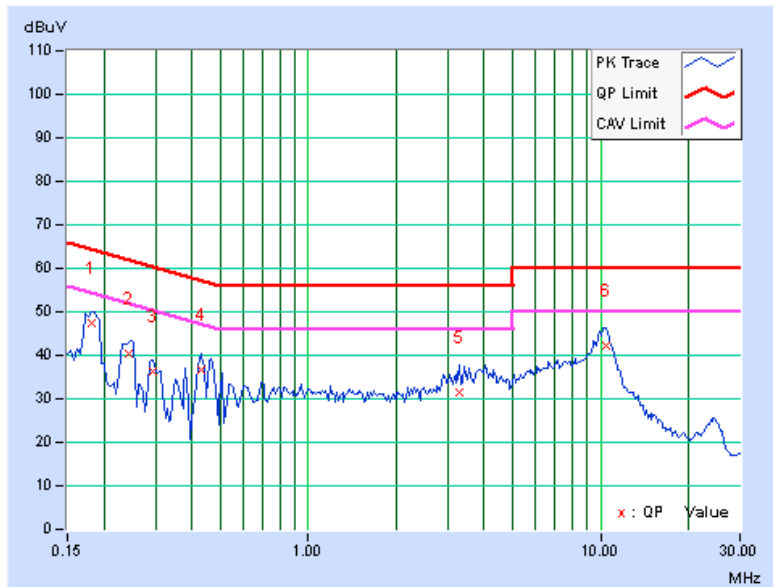



A D T

PHASE	Line 1	6dB BANDWIDTH	9kHz
CHANNEL	Channel 64	TEST MODE	B1 (Without MSR & Main Ant.)

No	Freq. [MHz]	Corr. Factor (dB)	Reading Value		Emission Level		Limit		Margin	
			[dB (uV)]		[dB (uV)]		[dB (uV)]		(dB)	
			Q.P.	AV.	Q.P.	AV.	Q.P.	AV.	Q.P.	AV.
1	0.15391	0.17	36.61	27.55	36.78	27.72	65.79	55.79	-29.01	-28.07
2	0.23166	0.17	39.25	28.79	39.42	28.96	62.39	52.39	-22.97	-23.43
3	0.34922	0.19	39.99	32.76	40.18	32.95	58.98	48.98	-18.80	-16.03
4	0.96641	0.23	37.51	31.98	37.74	32.21	56.00	46.00	-18.26	-13.79
5	1.44141	0.26	36.80	27.36	37.06	27.62	56.00	46.00	-18.94	-18.38
6	3.26172	0.36	35.56	22.97	35.92	23.33	56.00	46.00	-20.08	-22.67

- REMARKS:**
1. Q.P. and AV. are abbreviations of quasi-peak and average individually.
  2. The emission levels of other frequencies were very low against the limit.
  3. Margin value = Emission level - Limit value
  4. Correction factor = Insertion loss + Cable loss
  5. Emission Level = Correction Factor + Reading Value.

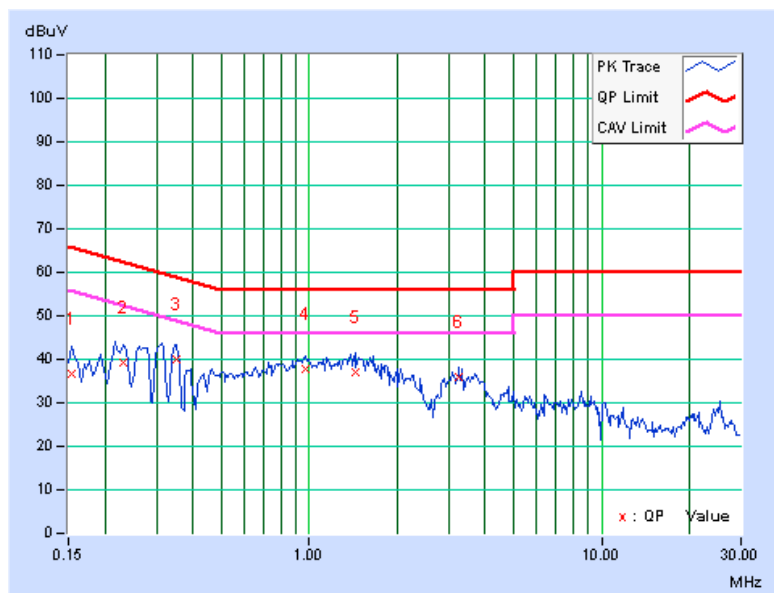



A D T

PHASE	Line 2	6dB BANDWIDTH	9kHz
CHANNEL	Channel 64	TEST MODE	B1 (Without MSR & Main Ant.)

No	Freq. [MHz]	Corr. Factor (dB)	Reading Value		Emission Level		Limit		Margin	
			[dB (uV)]		[dB (uV)]		[dB (uV)]		(dB)	
			Q.P.	AV.	Q.P.	AV.	Q.P.	AV.	Q.P.	AV.
1	0.15391	0.17	36.95	31.22	37.12	31.39	65.79	55.79	-28.67	-24.40
2	0.23203	0.15	40.22	31.84	40.37	31.99	62.38	52.38	-22.00	-20.38
3	0.31016	0.17	46.37	43.63	46.54	43.80	59.97	49.97	-13.43	-6.17
4	0.77109	0.19	39.74	34.39	39.93	34.58	56.00	46.00	-16.07	-11.42
5	0.95859	0.19	41.58	34.46	41.77	34.65	56.00	46.00	-14.23	-11.35
6	1.61328	0.24	40.97	33.86	41.21	34.10	56.00	46.00	-14.79	-11.90

- REMARKS:**
1. Q.P. and AV. are abbreviations of quasi-peak and average individually.
  2. The emission levels of other frequencies were very low against the limit.
  3. Margin value = Emission level - Limit value
  4. Correction factor = Insertion loss + Cable loss
  5. Emission Level = Correction Factor + Reading Value.

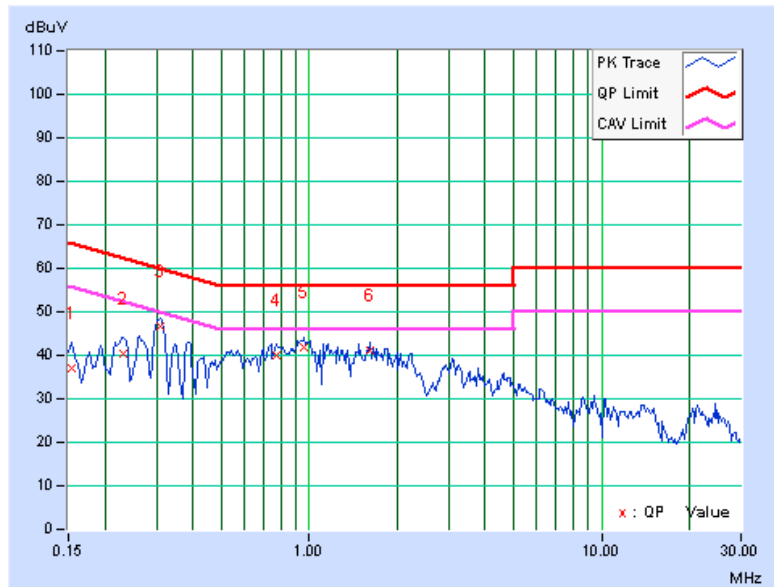

<b>PHASE</b>	Line 1	<b>6dB BANDWIDTH</b>	9kHz
<b>CHANNEL</b>	Channel 64	<b>TEST MODE</b>	<b>B2</b> (Without MSR & Main Ant.)

No	Freq. [MHz]	Corr. Factor (dB)	Reading Value		Emission Level		Limit		Margin	
			[dB (uV)]		[dB (uV)]		[dB (uV)]		(dB)	
			Q.P.	AV.	Q.P.	AV.	Q.P.	AV.	Q.P.	AV.
1	0.16172	0.17	46.95	31.89	47.12	32.06	65.38	55.38	-18.26	-23.32
2	0.21876	0.17	38.73	23.30	38.90	23.47	62.87	52.87	-23.96	-29.39
3	0.27500	0.18	30.93	16.15	31.11	16.33	60.97	50.97	-29.85	-34.63
4	0.46250	0.20	27.80	17.99	28.00	18.19	56.65	46.65	-28.64	-28.45
5	7.11328	0.44	29.47	22.90	29.91	23.34	60.00	50.00	-30.09	-26.66
6	10.95313	0.50	36.13	30.04	36.63	30.54	60.00	50.00	-23.37	-19.46

- REMARKS:**
1. Q.P. and AV. are abbreviations of quasi-peak and average individually.
  2. The emission levels of other frequencies were very low against the limit.
  3. Margin value = Emission level - Limit value
  4. Correction factor = Insertion loss + Cable loss
  5. Emission Level = Correction Factor + Reading Value.

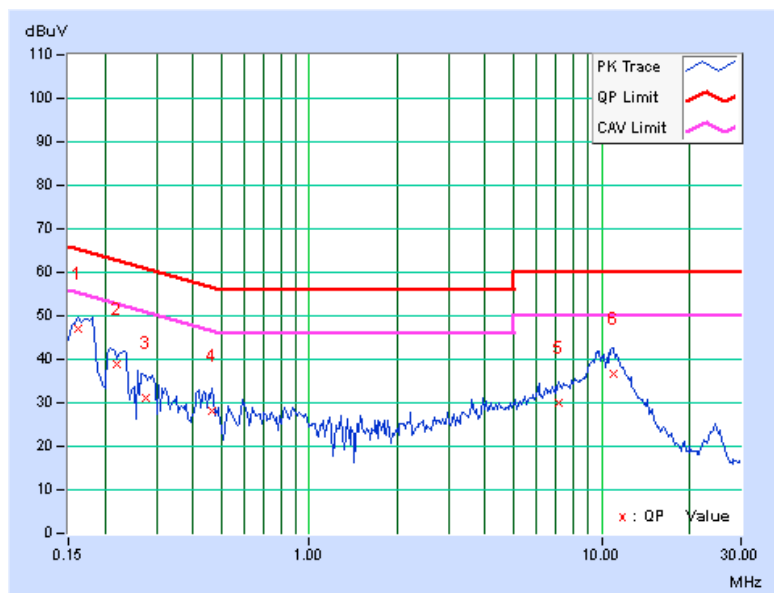

<b>PHASE</b>	Line 2	<b>6dB BANDWIDTH</b>	9kHz
<b>CHANNEL</b>	Channel 64	<b>TEST MODE</b>	<b>B2</b> (Without MSR & Main Ant.)

No	Freq. [MHz]	Corr. Factor (dB)	Reading Value		Emission Level		Limit		Margin	
			[dB (uV)]		[dB (uV)]		[dB (uV)]		(dB)	
			Q.P.	AV.	Q.P.	AV.	Q.P.	AV.	Q.P.	AV.
1	0.16953	0.16	44.17	29.69	44.33	29.85	64.98	54.98	-20.65	-25.13
2	0.23203	0.15	40.12	28.16	40.27	28.31	62.38	52.38	-22.10	-24.06
3	0.29063	0.16	35.89	26.49	36.05	26.65	60.51	50.51	-24.45	-23.85
4	0.46641	0.18	36.66	30.04	36.84	30.22	56.58	46.58	-19.74	-16.36
5	3.88672	0.37	31.47	22.49	31.84	22.86	56.00	46.00	-24.16	-23.14
6	10.41016	0.58	39.02	33.69	39.60	34.27	60.00	50.00	-20.40	-15.73

- REMARKS:**
1. Q.P. and AV. are abbreviations of quasi-peak and average individually.
  2. The emission levels of other frequencies were very low against the limit.
  3. Margin value = Emission level - Limit value
  4. Correction factor = Insertion loss + Cable loss
  5. Emission Level = Correction Factor + Reading Value.

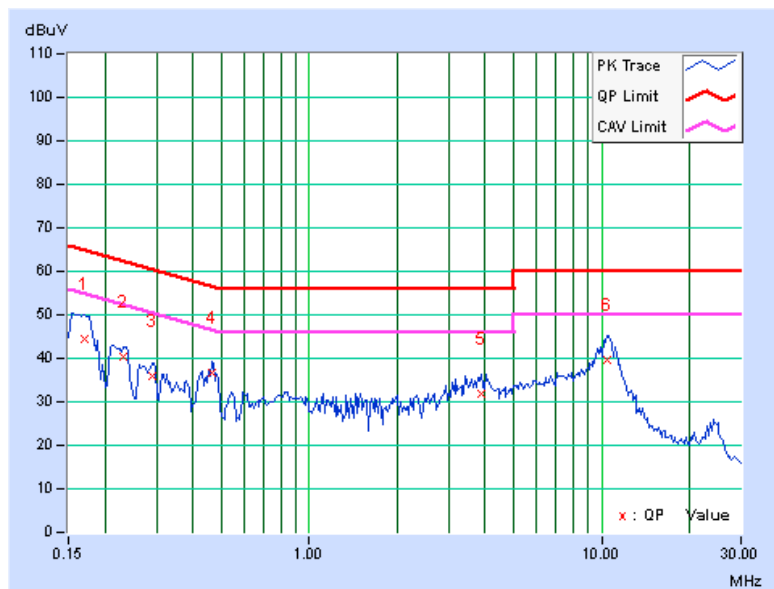



A D T

PHASE	Line 1	6dB BANDWIDTH	9kHz
CHANNEL	Channel 64	TEST MODE	C1 (Without MSR & Aux Ant.)

No	Freq. [MHz]	Corr. Factor (dB)	Reading Value		Emission Level		Limit		Margin	
			[dB (uV)]		[dB (uV)]		[dB (uV)]		(dB)	
			Q.P.	AV.	Q.P.	AV.	Q.P.	AV.	Q.P.	AV.
1	0.23203	0.17	39.57	29.60	39.74	29.77	62.38	52.38	-22.63	-22.60
2	0.31272	0.19	40.91	35.50	41.10	35.69	59.90	49.90	-18.80	-14.21
3	0.95859	0.23	37.61	31.88	37.84	32.11	56.00	46.00	-18.16	-13.89
4	1.52734	0.27	36.22	28.48	36.49	28.75	56.00	46.00	-19.51	-17.25
5	3.19141	0.35	32.77	23.91	33.12	24.26	56.00	46.00	-22.88	-21.74
6	3.81641	0.38	32.66	24.55	33.04	24.93	56.00	46.00	-22.96	-21.07

- REMARKS:**
1. Q.P. and AV. are abbreviations of quasi-peak and average individually.
  2. The emission levels of other frequencies were very low against the limit.
  3. Margin value = Emission level - Limit value
  4. Correction factor = Insertion loss + Cable loss
  5. Emission Level = Correction Value + Reading Value.

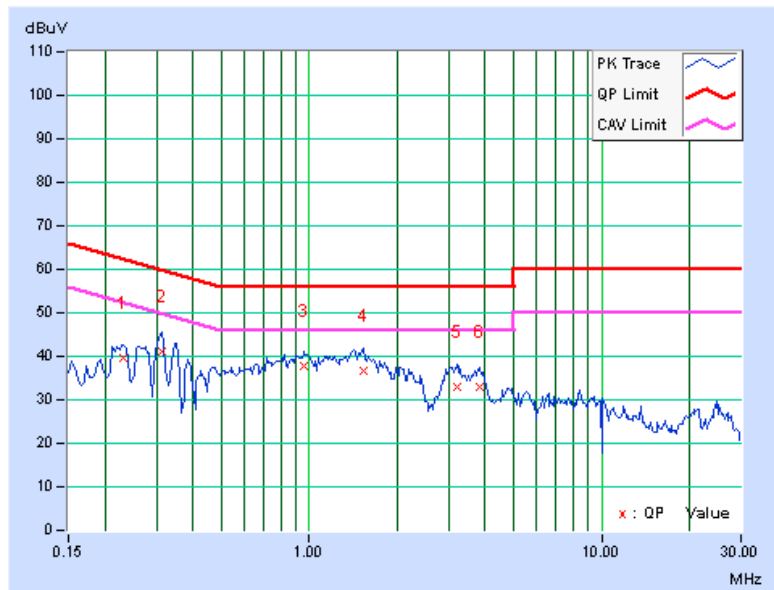



A D T

<b>PHASE</b>	Line 2	<b>6dB BANDWIDTH</b>	9kHz
<b>CHANNEL</b>	Channel 64	<b>TEST MODE</b>	C1 (Without MSR & Aux Ant.)

No	Freq. [MHz]	Corr. Factor (dB)	Reading Value		Emission Level		Limit		Margin	
			[dB (uV)]		[dB (uV)]		[dB (uV)]		(dB)	
			Q.P.	AV.	Q.P.	AV.	Q.P.	AV.	Q.P.	AV.
1	0.15391	0.17	36.03	31.16	36.20	31.33	65.79	55.79	-29.59	-24.46
2	0.22812	0.15	39.61	31.26	39.76	31.41	62.52	52.52	-22.75	-21.10
3	0.31016	0.17	46.31	43.18	46.48	43.35	59.97	49.97	-13.49	-6.62
4	0.77109	0.19	39.26	33.93	39.45	34.12	56.00	46.00	-16.55	-11.88
5	0.95469	0.19	39.97	32.12	40.16	32.31	56.00	46.00	-15.84	-13.69
6	1.65234	0.24	39.55	33.32	39.79	33.56	56.00	46.00	-16.21	-12.44

- REMARKS:**
1. Q.P. and AV. are abbreviations of quasi-peak and average individually.
  2. The emission levels of other frequencies were very low against the limit.
  3. Margin value = Emission level - Limit value
  4. Correction factor = Insertion loss + Cable loss
  5. Emission Level = Correction Factor + Reading Value.

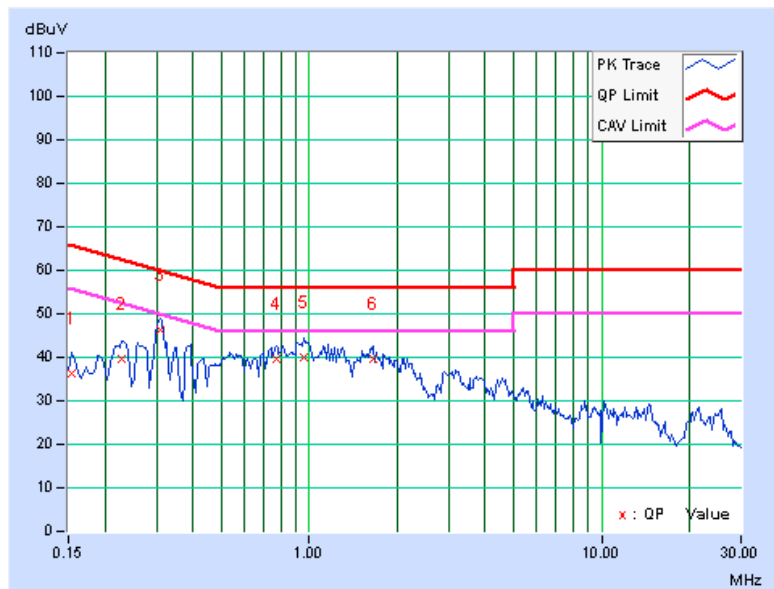





A D T

PHASE	Line 1	6dB BANDWIDTH	9kHz
CHANNEL	Channel 64	TEST MODE	C2 (Without MSR & Aux Ant.)

No	Freq. [MHz]	Corr. Factor (dB)	Reading Value		Emission Level		Limit		Margin	
			[dB (uV)]		[dB (uV)]		[dB (uV)]		(dB)	
			Q.P.	AV.	Q.P.	AV.	Q.P.	AV.	Q.P.	AV.
1	0.16172	0.17	47.11	31.93	47.28	32.10	65.38	55.38	-18.10	-23.28
2	0.23203	0.17	39.99	25.07	40.16	25.24	62.38	52.38	-22.21	-27.13
3	0.29453	0.18	32.78	18.98	32.96	19.16	60.40	50.40	-27.43	-31.23
4	5.65625	0.41	26.67	19.58	27.08	19.99	60.00	50.00	-32.92	-30.01
5	9.58203	0.47	35.63	29.83	36.10	30.30	60.00	50.00	-23.90	-19.70
6	11.29688	0.51	35.61	29.79	36.12	30.30	60.00	50.00	-23.88	-19.70

- REMARKS:**
1. Q.P. and AV. are abbreviations of quasi-peak and average individually.
  2. The emission levels of other frequencies were very low against the limit.
  3. Margin value = Emission level - Limit value
  4. Correction factor = Insertion loss + Cable loss
  5. Emission Level = Correction Factor + Reading Value.

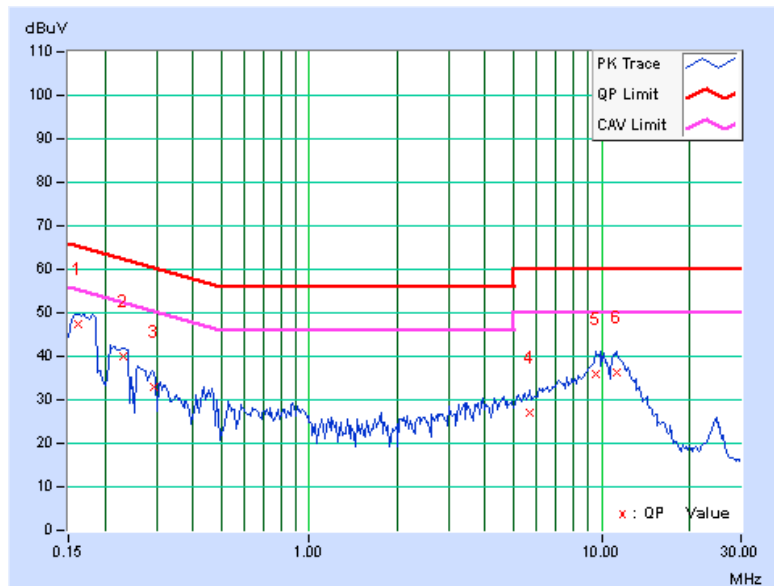



A D T

PHASE	Line 2	6dB BANDWIDTH	9kHz
CHANNEL	Channel 64	TEST MODE	C2 (Without MSR & Aux Ant.)

No	Freq. [MHz]	Corr. Factor (dB)	Reading Value		Emission Level		Limit		Margin	
			[dB (uV)]		[dB (uV)]		[dB (uV)]		(dB)	
			Q.P.	AV.	Q.P.	AV.	Q.P.	AV.	Q.P.	AV.
1	0.16172	0.17	47.52	32.81	47.69	32.98	65.38	55.38	-17.69	-22.40
2	0.21749	0.15	39.69	26.72	39.84	26.87	62.91	52.91	-23.07	-26.04
3	0.29063	0.16	36.82	26.81	36.98	26.97	60.51	50.51	-23.52	-23.53
4	0.46250	0.18	36.18	28.76	36.36	28.94	56.65	46.65	-20.29	-17.71
5	0.46250	0.18	36.06	28.62	36.24	28.80	56.65	46.65	-20.41	-17.85
6	10.73047	0.59	39.25	33.84	39.84	34.43	60.00	50.00	-20.16	-15.57

- REMARKS:**
1. Q.P. and AV. are abbreviations of quasi-peak and average individually.
  2. The emission levels of other frequencies were very low against the limit.
  3. Margin value = Emission level - Limit value
  4. Correction factor = Insertion loss + Cable loss
  5. Emission Level = Correction Factor + Reading Value.

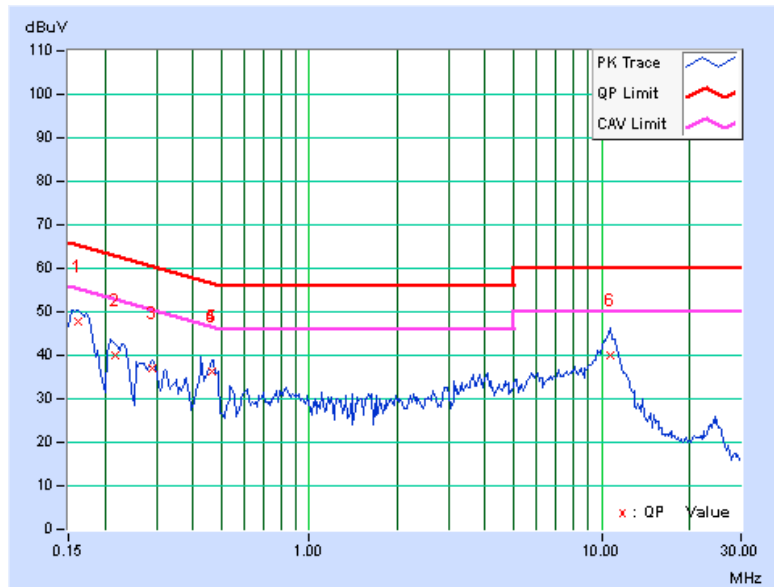



A D T

<b>PHASE</b>	Line 1	<b>6dB BANDWIDTH</b>	9kHz
<b>CHANNEL</b>	Channel 116	<b>TEST MODE</b>	A1 (With MSR & Main Ant.)

No	Freq. [MHz]	Corr. Factor (dB)	Reading Value		Emission Level		Limit		Margin	
			[dB (uV)]		[dB (uV)]		[dB (uV)]		(dB)	
			Q.P.	AV.	Q.P.	AV.	Q.P.	AV.	Q.P.	AV.
1	0.23203	0.17	39.47	29.52	39.64	29.69	62.38	52.38	-22.73	-22.68
2	0.30881	0.19	41.24	38.66	41.43	38.85	60.00	50.00	-18.58	-11.16
3	0.95469	0.23	36.63	30.25	36.86	30.48	56.00	46.00	-19.14	-15.52
4	1.43359	0.26	36.92	28.72	37.18	28.98	56.00	46.00	-18.82	-17.02
5	3.00000	0.34	32.80	24.33	33.14	24.67	56.00	46.00	-22.86	-21.33
6	3.91406	0.39	32.44	25.00	32.83	25.39	56.00	46.00	-23.17	-20.61

- REMARKS:**
1. Q.P. and AV. are abbreviations of quasi-peak and average individually.
  2. The emission levels of other frequencies were very low against the limit.
  3. Margin value = Emission level - Limit value
  4. Correction factor = Insertion loss + Cable loss
  5. Emission Level = Correction Factor + Reading Value.

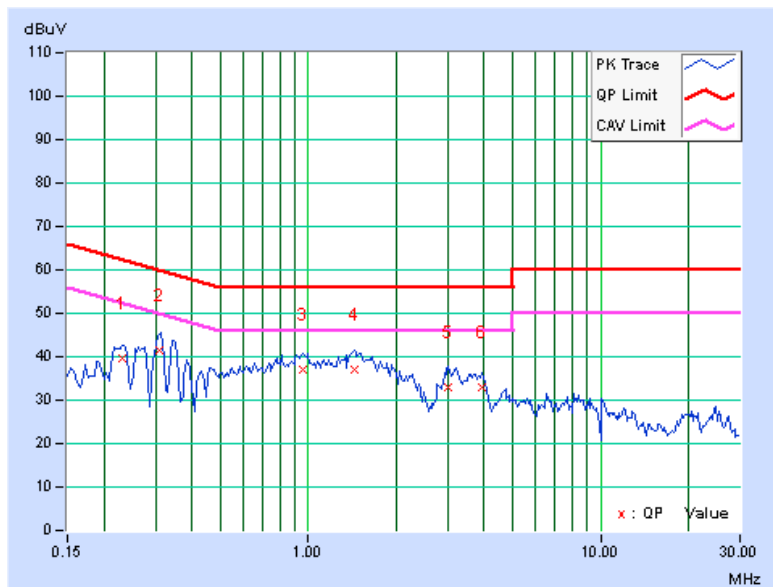



A D T

PHASE	Line 2	6dB BANDWIDTH	9kHz
CHANNEL	Channel 116	TEST MODE	A1 (With MSR & Main Ant.)

No	Freq. [MHz]	Corr. Factor (dB)	Reading Value		Emission Level		Limit		Margin	
			[dB (uV)]		[dB (uV)]		[dB (uV)]		(dB)	
			Q.P.	AV.	Q.P.	AV.	Q.P.	AV.	Q.P.	AV.
1	0.23203	0.15	40.38	32.20	40.53	32.35	62.38	52.38	-21.84	-20.02
2	0.31016	0.17	46.29	43.10	46.46	43.27	59.97	49.97	-13.51	-6.70
3	0.77109	0.19	39.22	34.11	39.41	34.30	56.00	46.00	-16.59	-11.70
4	0.96250	0.19	40.79	34.32	40.98	34.51	56.00	46.00	-15.02	-11.49
5	1.65625	0.24	39.45	33.62	39.69	33.86	56.00	46.00	-16.31	-12.14
6	3.12500	0.33	32.73	25.75	33.06	26.08	56.00	46.00	-22.94	-19.92

- REMARKS:**
1. Q.P. and AV. are abbreviations of quasi-peak and average individually.
  2. The emission levels of other frequencies were very low against the limit.
  3. Margin value = Emission level - Limit value
  4. Correction factor = Insertion loss + Cable loss
  5. Emission Level = Correction Factor + Reading Value.

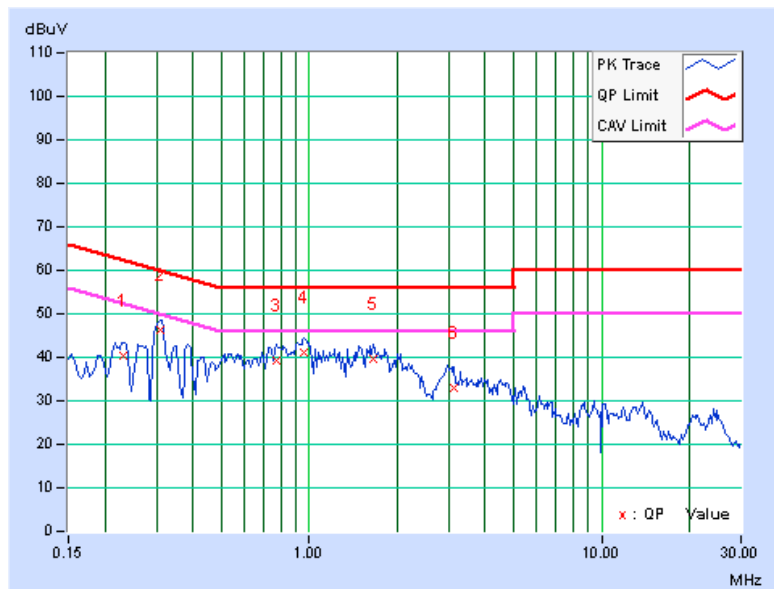



A D T

PHASE	Line 1	6dB BANDWIDTH	9kHz
CHANNEL	Channel 116	TEST MODE	A2 (With MSR & Main Ant.)

No	Freq. [MHz]	Corr. Factor (dB)	Reading Value		Emission Level		Limit		Margin	
			[dB (uV)]		[dB (uV)]		[dB (uV)]		(dB)	
			Q.P.	AV.	Q.P.	AV.	Q.P.	AV.	Q.P.	AV.
1	0.18125	0.17	47.39	34.16	47.56	34.33	64.43	54.43	-16.87	-20.10
2	0.23984	0.18	39.19	27.49	39.37	27.67	62.10	52.10	-22.74	-24.44
3	0.30625	0.19	31.64	20.31	31.83	20.50	60.07	50.07	-28.25	-29.58
4	0.42734	0.20	31.23	14.25	31.43	14.45	57.30	47.30	-25.87	-32.85
5	6.84766	0.43	31.39	23.93	31.82	24.36	60.00	50.00	-28.18	-25.64
6	10.50391	0.49	37.89	31.42	38.38	31.91	60.00	50.00	-21.62	-18.09

- REMARKS:**
1. Q.P. and AV. are abbreviations of quasi-peak and average individually.
  2. The emission levels of other frequencies were very low against the limit.
  3. Margin value = Emission level - Limit value
  4. Correction factor = Insertion loss + Cable loss
  5. Emission Level = Correction Factor + Reading Value.

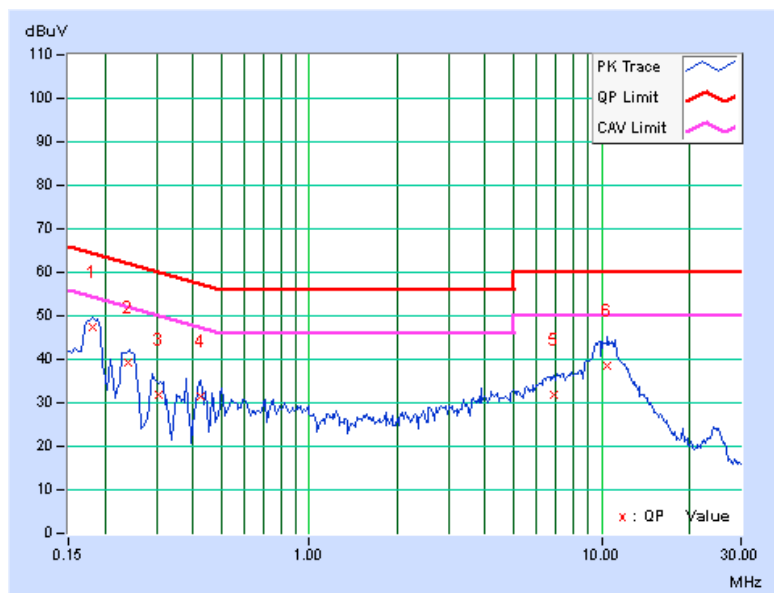



A D T

PHASE	Line 2	6dB BANDWIDTH	9kHz
CHANNEL	Channel 116	TEST MODE	A2 (With MSR & Main Ant.)

No	Freq. [MHz]	Corr. Factor (dB)	Reading Value		Emission Level		Limit		Margin	
			[dB (uV)]		[dB (uV)]		[dB (uV)]		(dB)	
			Q.P.	AV.	Q.P.	AV.	Q.P.	AV.	Q.P.	AV.
1	0.18125	0.16	47.37	34.80	47.53	34.96	64.43	54.43	-16.90	-19.47
2	0.24003	0.16	40.36	31.56	40.52	31.72	62.10	52.10	-21.58	-20.38
3	0.29844	0.16	34.70	26.33	34.86	26.49	60.29	50.29	-25.42	-23.79
4	0.41844	0.18	33.51	26.72	33.69	26.90	57.48	47.48	-23.79	-20.58
5	3.90234	0.37	32.88	24.31	33.25	24.68	56.00	46.00	-22.75	-21.32
6	10.28516	0.58	40.64	34.22	41.22	34.80	60.00	50.00	-18.78	-15.20

- REMARKS:**
1. Q.P. and AV. are abbreviations of quasi-peak and average individually.
  2. The emission levels of other frequencies were very low against the limit.
  3. Margin value = Emission level - Limit value
  4. Correction factor = Insertion loss + Cable loss
  5. Emission Level = Correction Factor + Reading Value.

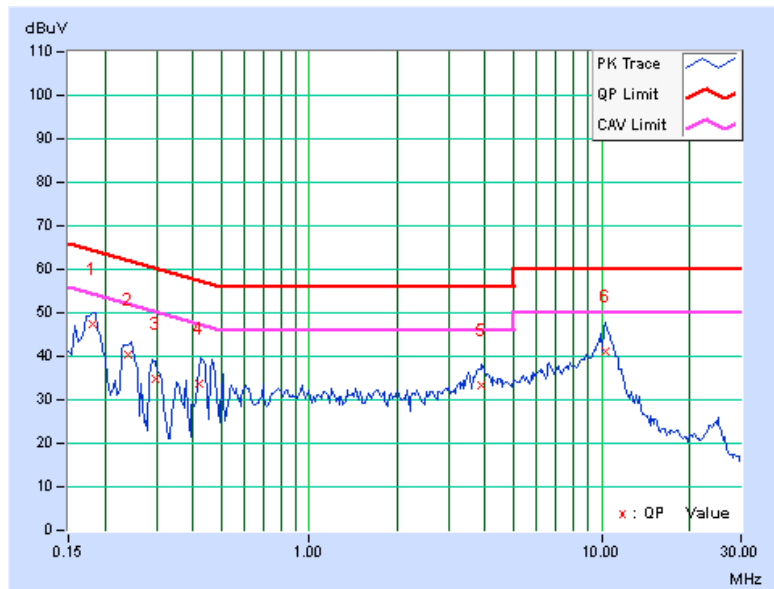



A D T

PHASE	Line 1	6dB BANDWIDTH	9kHz
CHANNEL	Channel 116	TEST MODE	B1 (Without MSR & Main Ant.)

No	Freq. [MHz]	Corr. Factor (dB)	Reading Value		Emission Level		Limit		Margin	
			[dB (uV)]		[dB (uV)]		[dB (uV)]		(dB)	
			Q.P.	AV.	Q.P.	AV.	Q.P.	AV.	Q.P.	AV.
1	0.15391	0.17	35.95	27.26	36.12	27.43	65.79	55.79	-29.67	-28.36
2	0.23203	0.17	39.66	28.96	39.83	29.13	62.38	52.38	-22.54	-23.24
3	0.31016	0.19	40.53	37.98	40.72	38.17	59.97	49.97	-19.25	-11.80
4	0.96250	0.23	37.67	32.84	37.90	33.07	56.00	46.00	-18.10	-12.93
5	1.53516	0.27	37.62	29.75	37.89	30.02	56.00	46.00	-18.11	-15.98
6	3.77734	0.38	34.42	25.02	34.80	25.40	56.00	46.00	-21.20	-20.60

- REMARKS:**
1. Q.P. and AV. are abbreviations of quasi-peak and average individually.
  2. The emission levels of other frequencies were very low against the limit.
  3. Margin value = Emission level - Limit value
  4. Correction factor = Insertion loss + Cable loss
  5. Emission Level = Correction Factor + Reading Value.

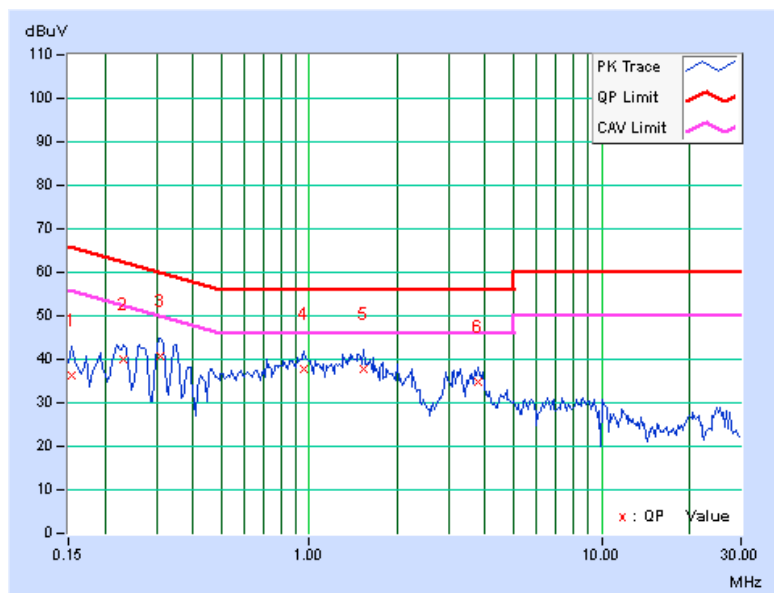



<b>PHASE</b>	Line 2	<b>6dB BANDWIDTH</b>	9kHz
<b>CHANNEL</b>	Channel 116	<b>TEST MODE</b>	<b>B1</b> (Without MSR & Main Ant.)

No	Freq. [MHz]	Corr. Factor (dB)	Reading Value		Emission Level		Limit		Margin	
			[dB (uV)]		[dB (uV)]		[dB (uV)]		(dB)	
			Q.P.	AV.	Q.P.	AV.	Q.P.	AV.	Q.P.	AV.
1	0.15391	0.17	36.87	31.30	37.04	31.47	65.79	55.79	-28.75	-24.32
2	0.23203	0.15	40.14	31.78	40.29	31.93	62.38	52.38	-22.08	-20.44
<b>3</b>	<b>0.30772</b>	<b>0.17</b>	<b>46.78</b>	<b>44.26</b>	<b>46.95</b>	<b>44.43</b>	<b>60.03</b>	<b>50.03</b>	<b>-13.09</b>	<b>-5.61</b>
4	0.95859	0.19	41.56	34.44	41.75	34.63	56.00	46.00	-14.25	-11.37
5	1.61719	0.24	41.19	34.40	41.43	34.64	56.00	46.00	-14.57	-11.36
6	2.23438	0.28	37.71	28.81	37.99	29.09	56.00	46.00	-18.01	-16.91

- REMARKS:**
1. Q.P. and AV. are abbreviations of quasi-peak and average individually.
  2. The emission levels of other frequencies were very low against the limit.
  3. Margin value = Emission level - Limit value
  4. Correction factor = Insertion loss + Cable loss
  5. Emission Level = Correction Factor + Reading Value.

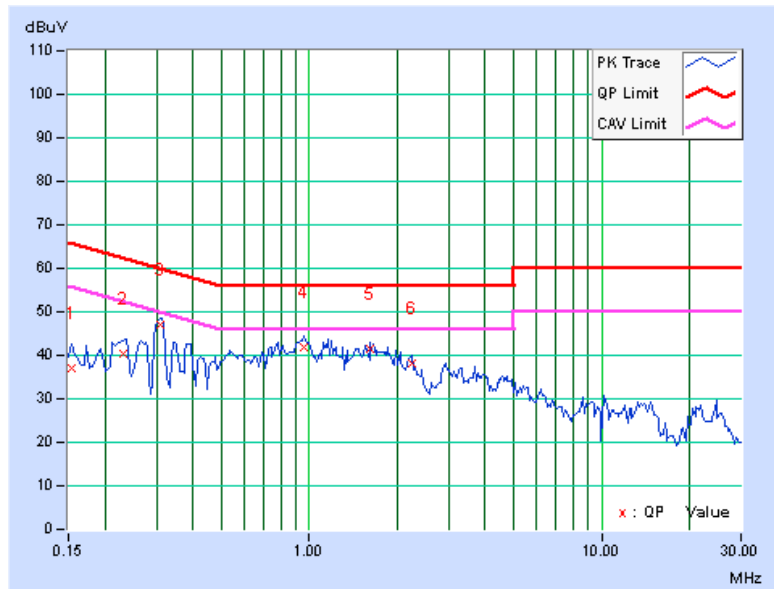





A D T

PHASE	Line 1	6dB BANDWIDTH	9kHz
CHANNEL	Channel 116	TEST MODE	B2 (Without MSR & Main Ant.)

No	Freq. [MHz]	Corr. Factor (dB)	Reading Value		Emission Level		Limit		Margin	
			[dB (uV)]		[dB (uV)]		[dB (uV)]		(dB)	
			Q.P.	AV.	Q.P.	AV.	Q.P.	AV.	Q.P.	AV.
1	0.16172	0.17	47.11	32.09	47.28	32.26	65.38	55.38	-18.10	-23.12
2	0.23203	0.17	39.77	25.17	39.94	25.34	62.38	52.38	-22.43	-27.03
3	0.27109	0.18	34.27	20.52	34.45	20.70	61.08	51.08	-26.63	-30.38
4	0.87266	0.22	25.88	20.16	26.10	20.38	56.00	46.00	-29.90	-25.62
5	3.38672	0.36	25.07	15.90	25.43	16.26	56.00	46.00	-30.57	-29.74
6	9.83594	0.48	36.89	30.72	37.37	31.20	60.00	50.00	-22.63	-18.80

- REMARKS:**
1. Q.P. and AV. are abbreviations of quasi-peak and average individually.
  2. The emission levels of other frequencies were very low against the limit.
  3. Margin value = Emission level - Limit value
  4. Correction factor = Insertion loss + Cable loss
  5. Emission Level = Correction Factor + Reading Value.

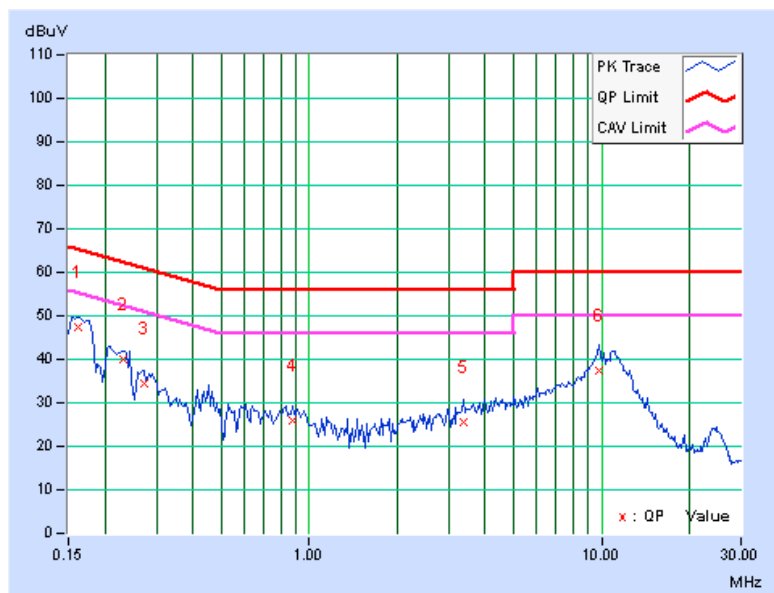

PHASE	Line 2	6dB BANDWIDTH	9kHz
CHANNEL	Channel 116	TEST MODE	B2 (Without MSR & Main Ant.)

No	Freq. [MHz]	Corr. Factor (dB)	Reading Value		Emission Level		Limit		Margin	
			[dB (uV)]		[dB (uV)]		[dB (uV)]		(dB)	
			Q.P.	AV.	Q.P.	AV.	Q.P.	AV.	Q.P.	AV.
1	0.15781	0.17	43.64	28.70	43.81	28.87	65.58	55.58	-21.77	-26.71
2	0.23203	0.15	40.22	28.12	40.37	28.27	62.38	52.38	-22.00	-24.10
3	0.47031	0.18	35.12	26.91	35.30	27.09	56.51	46.51	-21.21	-19.42
4	1.71875	0.25	25.41	15.17	25.66	15.42	56.00	46.00	-30.34	-30.58
5	3.78516	0.37	32.29	22.75	32.66	23.12	56.00	46.00	-23.34	-22.88
6	10.46484	0.58	39.45	34.10	40.03	34.68	60.00	50.00	-19.97	-15.32

- REMARKS:**
1. Q.P. and AV. are abbreviations of quasi-peak and average individually.
  2. The emission levels of other frequencies were very low against the limit.
  3. Margin value = Emission level - Limit value
  4. Correction factor = Insertion loss + Cable loss
  5. Emission Level = Correction Factor + Reading Value.

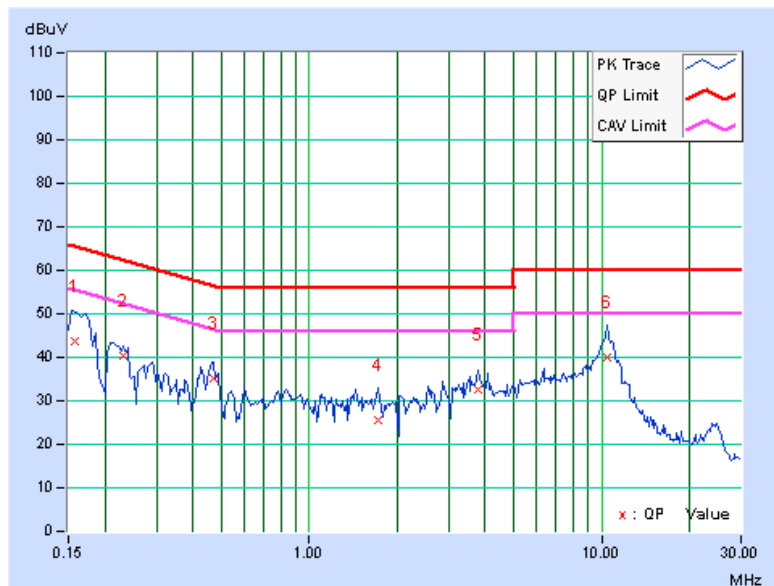

<b>PHASE</b>	Line 1	<b>6dB BANDWIDTH</b>	9kHz
<b>CHANNEL</b>	Channel 116	<b>TEST MODE</b>	C1 (Without MSR & Aux Ant.)

No	Freq. [MHz]	Corr. Factor (dB)	Reading Value		Emission Level		Limit		Margin	
			[dB (uV)]		[dB (uV)]		[dB (uV)]		(dB)	
			Q.P.	AV.	Q.P.	AV.	Q.P.	AV.	Q.P.	AV.
1	0.22812	0.17	38.65	28.99	38.82	29.16	62.52	52.52	-23.69	-23.35
2	0.31016	0.19	40.95	37.40	41.14	37.59	59.97	49.97	-18.83	-12.38
3	0.34531	0.19	40.75	33.32	40.94	33.51	59.07	49.07	-18.13	-15.56
4	0.95859	0.23	37.59	32.26	37.82	32.49	56.00	46.00	-18.18	-13.51
5	1.40234	0.26	36.62	28.54	36.88	28.80	56.00	46.00	-19.12	-17.20
6	3.26172	0.36	33.82	23.45	34.18	23.81	56.00	46.00	-21.82	-22.19

- REMARKS:**
1. Q.P. and AV. are abbreviations of quasi-peak and average individually.
  2. The emission levels of other frequencies were very low against the limit.
  3. Margin value = Emission level - Limit value
  4. Correction factor = Insertion loss + Cable loss
  5. Emission Level = Correction Factor + Reading Value.

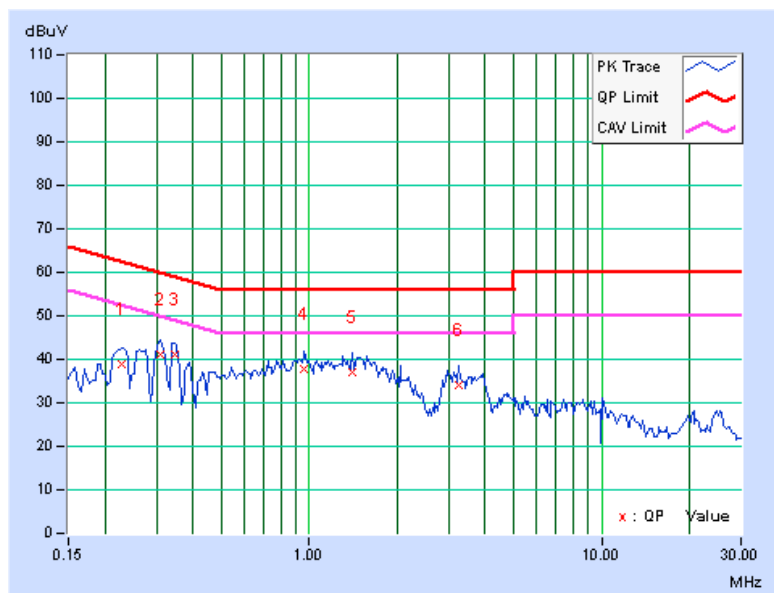



A D T

PHASE	Line 2	6dB BANDWIDTH	9kHz
CHANNEL	Channel 116	TEST MODE	C1 (Without MSR & Aux Ant.)

No	Freq. [MHz]	Corr. Factor (dB)	Reading Value		Emission Level		Limit		Margin	
			[dB (uV)]		[dB (uV)]		[dB (uV)]		(dB)	
			Q.P.	AV.	Q.P.	AV.	Q.P.	AV.	Q.P.	AV.
1	0.31016	0.17	45.86	42.35	46.03	42.52	59.97	49.97	-13.94	-7.45
2	0.38438	0.18	40.08	36.78	40.26	36.96	58.18	48.18	-17.93	-11.23
3	0.95859	0.19	40.81	34.24	41.00	34.43	56.00	46.00	-15.00	-11.57
4	1.60938	0.24	39.37	33.30	39.61	33.54	56.00	46.00	-16.39	-12.46
5	2.97266	0.32	31.68	25.52	32.00	25.84	56.00	46.00	-24.00	-20.16
6	4.49609	0.40	28.95	23.81	29.35	24.21	56.00	46.00	-26.65	-21.79

- REMARKS:**
1. Q.P. and AV. are abbreviations of quasi-peak and average individually.
  2. The emission levels of other frequencies were very low against the limit.
  3. Margin value = Emission level - Limit value
  4. Correction factor = Insertion loss + Cable loss
  5. Emission Level = Correction Factor + Reading Value.

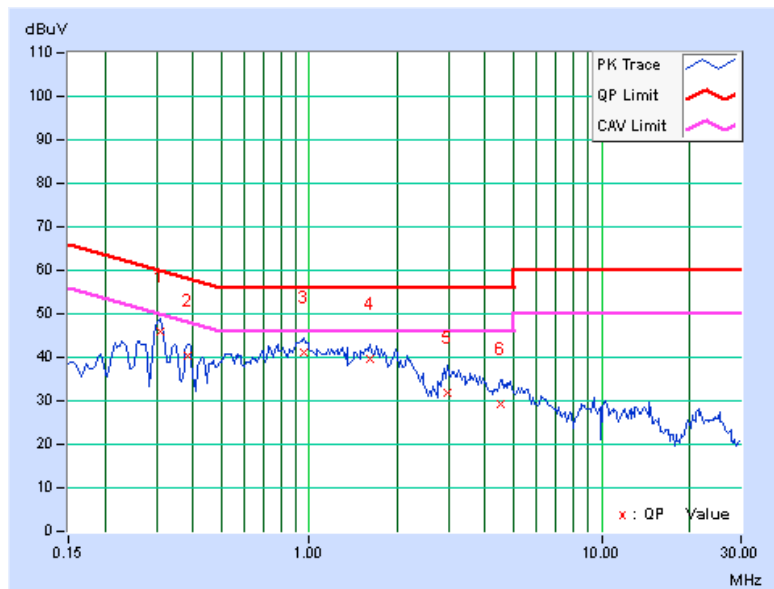



A D T

PHASE	Line 1	6dB BANDWIDTH	9kHz
CHANNEL	Channel 116	TEST MODE	C2 (Without MSR & Aux Ant.)

No	Freq. [MHz]	Corr. Factor (dB)	Reading Value		Emission Level		Limit		Margin	
			[dB (uV)]		[dB (uV)]		[dB (uV)]		(dB)	
			Q.P.	AV.	Q.P.	AV.	Q.P.	AV.	Q.P.	AV.
1	0.17344	0.17	46.77	31.87	46.94	32.04	64.79	54.79	-17.85	-22.75
2	0.21749	0.17	39.49	24.38	39.66	24.55	62.91	52.91	-23.25	-28.36
3	0.46856	0.20	28.43	18.03	28.63	18.23	56.54	46.54	-27.91	-28.31
4	5.74219	0.42	26.74	19.25	27.16	19.67	60.00	50.00	-32.84	-30.33
5	9.96484	0.48	36.49	30.86	36.97	31.34	60.00	50.00	-23.03	-18.66
6	11.06641	0.51	36.04	30.02	36.55	30.53	60.00	50.00	-23.45	-19.47

- REMARKS:**
1. Q.P. and AV. are abbreviations of quasi-peak and average individually.
  2. The emission levels of other frequencies were very low against the limit.
  3. Margin value = Emission level - Limit value
  4. Correction factor = Insertion loss + Cable loss
  5. Emission Level = Correction Factor + Reading Value.

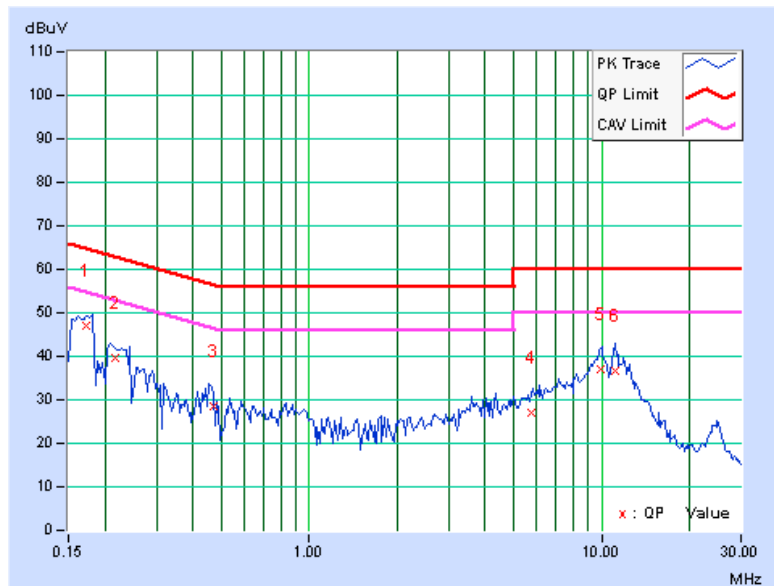



A D T

PHASE	Line 2	6dB BANDWIDTH	9kHz
CHANNEL	Channel 116	TEST MODE	C2 (Without MSR & Aux Ant.)

No	Freq. [MHz]	Corr. Factor (dB)	Reading Value		Emission Level		Limit		Margin	
			[dB (uV)]		[dB (uV)]		[dB (uV)]		(dB)	
			Q.P.	AV.	Q.P.	AV.	Q.P.	AV.	Q.P.	AV.
1	0.18125	0.16	42.29	25.07	42.45	25.23	64.43	54.43	-21.98	-29.20
2	0.23203	0.15	39.83	28.08	39.98	28.23	62.38	52.38	-22.39	-24.14
3	0.29063	0.16	36.70	26.67	36.86	26.83	60.51	50.51	-23.64	-23.67
4	0.46641	0.18	36.66	30.00	36.84	30.18	56.58	46.58	-19.74	-16.40
5	3.78906	0.37	32.08	22.22	32.45	22.59	56.00	46.00	-23.55	-23.41
6	10.57813	0.58	39.39	33.30	39.97	33.88	60.00	50.00	-20.03	-16.12

- REMARKS:**
1. Q.P. and AV. are abbreviations of quasi-peak and average individually.
  2. The emission levels of other frequencies were very low against the limit.
  3. Margin value = Emission level - Limit value
  4. Correction factor = Insertion loss + Cable loss
  5. Emission Level = Correction Factor + Reading Value.

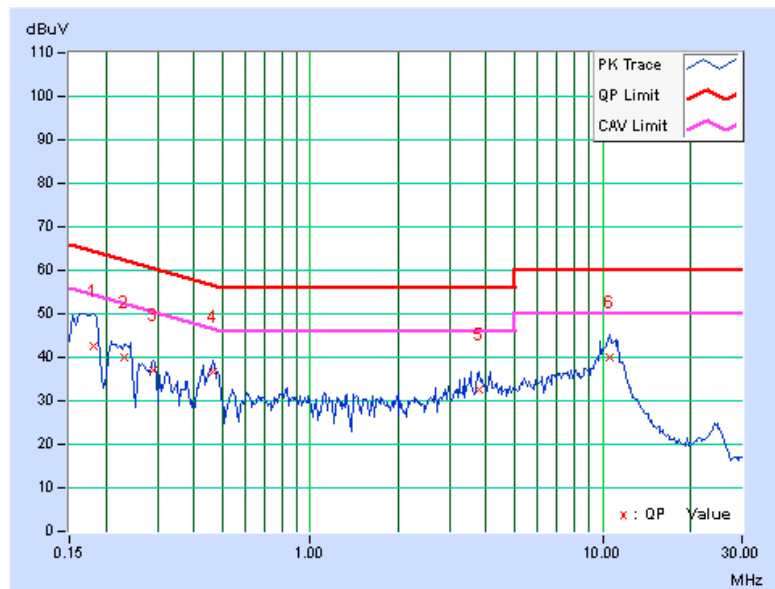

### 4.3 PEAK TRANSMIT POWER MEASUREMENT

#### 4.3.1 LIMITS OF PEAK TRANSMIT POWER MEASUREMENT

FREQUENCY BAND	LIMIT
5.150 ~ 5.250GHz	The lesser of 50mW (17dBm) or 4dBm + 10logB
5.250 ~ 5.350GHz	The lesser of 250mW (24dBm) or 11dBm + 10logB
5.470 ~ 5.725GHz	The lesser of 250mW (24dBm) or 11dBm + 10logB

**NOTE:** Where B is the 26dB emission bandwidth in MHz.

#### 4.3.2 TEST SETUP

##### FOR POWER OUTPUT MEASUREMENT

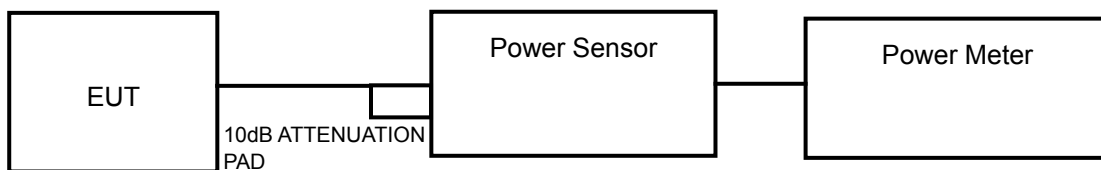

##### FOR 26dB BANDWIDTH

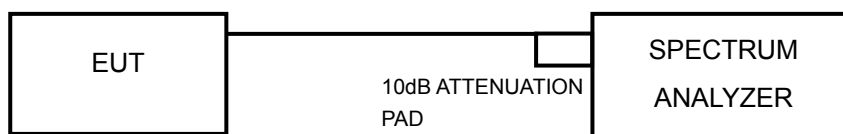

#### 4.3.3 TEST INSTRUMENTS

Refer to section 4.1.3 to get information of above instrument.

#### 4.3.4 TEST PROCEDURE

##### FOR AVERAGE POWER MEASUREMENT

Method PM is used to perform output power measurement, trigger and gating function of wide band power meter is enabled to measure max output power of TX on burst. Duty factor is not added to measured value.

##### FOR 26dB BANDWIDTH

- 1) Set RBW = approximately 1% of the emission bandwidth.
- 2) Set the VBW > RBW.
- 3) Detector = Peak.
- 4) Trace mode = max hold.
- 5) Measure the maximum width of the emission that is 26 dB down from the peak of the emission. Compare this with the RBW setting of the analyzer. Readjust RBW and repeat measurement as needed until the RBW/EBW ratio is approximately 1%.

#### 4.3.5 DEVIATION FROM TEST STANDARD

No deviation.

#### 4.3.6 EUT OPERATING CONDITIONS

The software provided by client to enable the EUT under transmission condition continuously at specific channel frequencies individually.





### 4.3.7 TEST RESULTS

#### Test Mode A1 (With MSR& Main Ant.)

POWER OUTPUT: 802.11a

Channel	Frequency (MHz)	Chain	Data Rate							
			6Mbps	9Mbps	12Mbps	18Mbps	24Mbps	36Mbps	48Mbps	54Mbps
CH 36	5180 MHz	MAIN	13.29	13.21	13.20	13.22	13.18	13.21	13.26	13.22
CH 40	5200 MHz	MAIN	13.36	13.32	13.33	13.35	13.28	13.27	13.26	13.21
CH 48	5240 MHz	MAIN	13.58	13.49	13.42	13.48	13.47	13.48	13.51	13.52
CH 52	5260 MHz	MAIN	18.64	18.62	18.60	18.62	18.59	18.53	18.59	18.61
CH 60	5300 MHz	MAIN	18.68	18.63	18.61	18.63	18.59	18.55	18.57	18.52
CH 64	5320 MHz	MAIN	18.71	18.70	18.66	18.60	18.67	18.61	18.63	18.68
CH 100	5500 MHz	MAIN	17.03	17.01	16.95	16.92	16.97	16.98	16.99	16.93
CH 116	5580MHz	MAIN	18.99	18.93	18.91	18.90	18.93	18.83	18.86	18.95
CH 140	5700 MHz	MAIN	16.95	16.91	16.90	16.84	16.88	16.83	16.87	16.89

#### 802.11n (20MHz)

Channel	Frequency (MHz)	Chain	Data Rate							
			6Mbps	9Mbps	12Mbps	18Mbps	24Mbps	36Mbps	48Mbps	54Mbps
CH 36	5180 MHz	MAIN	13.50	13.44	13.42	13.43	13.48	13.42	13.41	13.49
CH 40	5200 MHz	MAIN	13.49	13.46	13.47	13.38	13.44	13.48	13.42	13.40
CH 48	5240 MHz	MAIN	13.52	13.50	13.48	13.46	13.42	13.49	13.43	13.50
CH 52	5260 MHz	MAIN	18.15	18.11	18.12	18.13	18.14	18.08	18.07	18.03
CH 60	5300 MHz	MAIN	18.24	18.22	18.20	18.17	18.16	18.15	18.18	18.20
CH 64	5320 MHz	MAIN	18.11	18.09	18.03	18.04	18.06	18.01	18.03	18.07
CH 100	5500 MHz	MAIN	16.93	16.91	16.85	16.84	16.83	16.87	16.90	16.92
CH 116	5580MHz	MAIN	18.11	18.10	18.09	18.04	18.03	18.08	18.02	18.09
CH 140	5700 MHz	MAIN	16.93	16.90	16.88	16.84	16.83	16.82	16.88	16.92



**26dB BANDWIDTH: 802.11a**

CHANNEL	CHANNEL FREQUENCY (MHz)	26dBc BANDWIDTH (MHz)	PASS / FAIL
36	5180	23.21	PASS
40	5200	22.56	PASS
48	5240	23.52	PASS
52	5260	39.62	PASS
60	5300	39.04	PASS
64	5320	41.49	PASS
100	5500	38.33	PASS
116	5580	41.94	PASS
140	5700	26.31	PASS

**802.11n (20MHz)**

CHANNEL	CHANNEL FREQUENCY (MHz)	26dBc BANDWIDTH (MHz)	PASS / FAIL
36	5180	24.19	PASS
40	5200	24.16	PASS
48	5240	24.31	PASS
52	5260	44.03	PASS
60	5300	40.67	PASS
64	5320	40.58	PASS
100	5500	37.92	PASS
116	5580	41.97	PASS
140	5700	40.52	PASS



### Test Mode B1 (Without MSR & Main Ant.)

POWER OUTPUT: 802.11a

Channel	Frequency (MHz)	Chain	Data Rate							
			6Mbps	9Mbps	12Mbps	18Mbps	24Mbps	36Mbps	48Mbps	54Mbps
CH 36	5180 MHz	MAIN	13.22	13.18	13.11	13.17	13.14	13.19	13.20	13.21
CH 40	5200 MHz	MAIN	13.19	13.17	13.11	13.15	13.10	13.16	13.08	13.09
CH 48	5240 MHz	MAIN	13.39	13.33	13.35	13.30	13.28	13.36	13.32	13.32
CH 52	5260 MHz	MAIN	18.34	18.31	18.28	18.21	18.24	18.27	18.20	18.24
CH 60	5300 MHz	MAIN	18.50	18.43	18.41	18.42	18.38	18.31	18.47	18.49
CH 64	5320 MHz	MAIN	18.52	18.50	18.48	18.44	18.42	18.40	18.46	18.41
CH 100	5500 MHz	MAIN	17.20	17.10	17.16	17.13	17.09	17.14	17.06	17.08
CH 116	5580MHz	MAIN	19.15	19.10	19.11	19.08	19.06	19.11	19.04	19.08
CH 140	5700 MHz	MAIN	17.08	17.01	16.98	16.93	17.04	17.03	17.00	16.94

### 802.11n (20MHz)

Channel	Frequency (MHz)	Chain	Data Rate							
			6Mbps	9Mbps	12Mbps	18Mbps	24Mbps	36Mbps	48Mbps	54Mbps
CH 36	5180 MHz	MAIN	13.30	13.28	13.22	13.24	13.26	13.19	13.27	13.26
CH 40	5200 MHz	MAIN	13.32	13.30	13.24	13.21	13.22	13.28	13.29	13.31
CH 48	5240 MHz	MAIN	13.36	13.32	13.30	13.33	13.37	13.29	13.28	13.27
CH 52	5260 MHz	MAIN	17.81	17.76	17.70	17.74	17.79	17.80	17.74	17.70
CH 60	5300 MHz	MAIN	18.02	18.01	18.00	17.96	17.95	17.98	18.01	17.93
CH 64	5320 MHz	MAIN	17.85	17.80	17.76	17.83	17.84	17.75	17.79	17.83
CH 100	5500 MHz	MAIN	17.42	17.40	17.31	17.34	17.38	17.36	17.26	17.33
CH 116	5580MHz	MAIN	18.68	18.60	18.61	18.63	18.64	18.59	18.61	18.57
CH 140	5700 MHz	MAIN	16.94	16.86	16.89	16.91	16.84	16.80	16.88	16.81



**26dB BANDWIDTH: 802.11a**

CHANNEL	CHANNEL FREQUENCY (MHz)	26dBc BANDWIDTH (MHz)	PASS / FAIL
36	5180	22.64	PASS
40	5200	23.29	PASS
48	5240	23.08	PASS
52	5260	39.46	PASS
60	5300	40.82	PASS
64	5320	40.81	PASS
100	5500	37.20	PASS
116	5580	42.49	PASS
140	5700	37.32	PASS

**802.11n (20MHz)**

CHANNEL	CHANNEL FREQUENCY (MHz)	26dBc BANDWIDTH (MHz)	PASS / FAIL
36	5180	24.72	PASS
40	5200	24.94	PASS
48	5240	23.86	PASS
52	5260	40.85	PASS
60	5300	42.51	PASS
64	5320	42.24	PASS
100	5500	41.23	PASS
116	5580	44.33	PASS
140	5700	38.14	PASS



### Test Mode C1 (Without MSR & Aux Ant.)

POWER OUTPUT: 802.11a

Channel	Frequency (MHz)	Chain	Data Rate							
			6Mbps	9Mbps	12Mbps	18Mbps	24Mbps	36Mbps	48Mbps	54Mbps
CH 36	5180 MHz	MAIN	13.22	13.20	13.18	13.17	13.16	13.15	13.18	13.20
CH 40	5200 MHz	MAIN	13.21	13.18	13.19	13.11	13.16	13.14	13.10	13.17
CH 48	5240 MHz	MAIN	13.39	13.31	13.30	13.33	13.38	13.28	13.29	13.27
CH 52	5260 MHz	MAIN	19.00	18.92	18.93	18.95	18.97	18.92	18.94	18.91
CH 60	5300 MHz	MAIN	19.22	19.21	19.20	19.19	19.11	19.16	19.15	19.19
CH 64	5320 MHz	MAIN	19.31	19.28	19.22	19.24	19.22	19.20	19.25	19.27
CH 100	5500 MHz	MAIN	17.20	17.18	17.12	17.16	17.18	17.11	17.09	17.14
CH 116	5580MHz	MAIN	19.15	19.10	19.08	19.06	19.11	19.08	19.06	19.07
CH 140	5700 MHz	MAIN	17.08	17.01	17.05	17.02	16.92	17.03	17.05	17.06

### 802.11n (20MHz)

Channel	Frequency (MHz)	Chain	Data Rate							
			6Mbps	9Mbps	12Mbps	18Mbps	24Mbps	36Mbps	48Mbps	54Mbps
CH 36	5180 MHz	MAIN	13.25	13.22	13.21	13.18	13.19	13.14	13.12	13.21
CH 40	5200 MHz	MAIN	13.14	13.12	13.11	13.01	13.05	13.09	13.10	13.11
CH 48	5240 MHz	MAIN	13.34	13.32	13.31	13.29	13.28	13.31	13.26	13.27
CH 52	5260 MHz	MAIN	18.19	18.17	18.16	18.10	18.14	18.12	18.16	18.09
CH 60	5300 MHz	MAIN	18.24	18.20	18.21	18.11	18.14	18.16	18.18	18.20
CH 64	5320 MHz	MAIN	18.48	18.44	18.40	18.42	18.36	18.34	18.33	18.42
CH 100	5500 MHz	MAIN	17.31	17.28	17.22	17.21	17.23	17.26	17.30	17.29
CH 116	5580MHz	MAIN	18.64	18.60	18.62	18.59	18.57	18.53	18.54	18.52
CH 140	5700 MHz	MAIN	17.04	17.01	17.03	16.96	16.97	16.92	16.91	16.93



**26dB BANDWIDTH: 802.11a**

CHANNEL	CHANNEL FREQUENCY (MHz)	26dBc BANDWIDTH (MHz)	PASS / FAIL
36	5180	22.78	PASS
40	5200	22.99	PASS
48	5240	23.02	PASS
52	5260	43.35	PASS
60	5300	44.28	PASS
64	5320	46.35	PASS
100	5500	37.64	PASS
116	5580	44.63	PASS
140	5700	29.61	PASS

**802.11n (20MHz)**

CHANNEL	CHANNEL FREQUENCY (MHz)	26dBc BANDWIDTH (MHz)	PASS / FAIL
36	5180	24.58	PASS
40	5200	24.42	PASS
48	5240	24.33	PASS
52	5260	42.94	PASS
60	5300	41.61	PASS
64	5320	43.05	PASS
100	5500	41.12	PASS
116	5580	43.36	PASS
140	5700	40.01	PASS

## 4.4 PEAK POWER SPECTRAL DENSITY MEASUREMENT

### 4.4.1 LIMITS OF PEAK POWER SPECTRAL DENSITY MEASUREMENT

FREQUENCY BAND	LIMIT
5.150 ~ 5.250GHz	4dBm
5.250 ~ 5.350GHz	11dBm
5.470 ~ 5.725GHz	11dBm

### 4.4.2 TEST SETUP

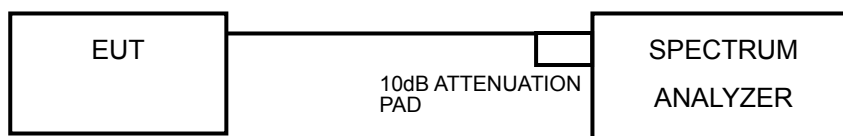

### 4.4.3 TEST INSTRUMENTS

Refer to section 4.1.3 to get information of above instrument.

### 4.4.4 TEST PROCEDURES

Using method SA-1

- 1) Set span to encompass the entire emission bandwidth (EBW) of the signal.
- 2) Set RBW = 1 MHz, Set VBW  $\geq$  3 MHz, Detector = RMS
- 3) Sweep time = auto, trigger set to "free run".
- 4) Trace average at least 100 traces in power averaging mode.
- 5) Record the max value

### 4.4.5 DEVIATION FROM TEST STANDARD

No deviation.

### 4.4.6 EUT OPERATING CONDITIONS

Same as 4.3.6.



A D T

#### 4.4.7 TEST RESULTS

##### Test Mode A1 (With MSR& Main Ant.)

###### 802.11a

CHANNEL	FREQUENCY (MHz)	PSD (dBm)	MAXIMUM LIMIT (dBm)	PASS/FAIL
36	5180	3.66	4	PASS
40	5200	3.43	4	PASS
48	5240	3.69	4	PASS
52	5260	8.56	11	PASS
60	5300	8.06	11	PASS
64	5320	8.60	11	PASS
100	5500	6.88	11	PASS
116	5580	8.42	11	PASS
140	5700	6.18	11	PASS

###### 802.11n (20MHz)

CHANNEL	FREQUENCY (MHz)	PSD (dBm)	MAXIMUM LIMIT (dBm)	PASS/FAIL
36	5180	3.33	4	PASS
40	5200	3.50	4	PASS
48	5240	3.62	4	PASS
52	5260	8.19	11	PASS
60	5300	7.88	11	PASS
64	5320	7.52	11	PASS
100	5500	6.65	11	PASS
116	5580	7.56	11	PASS
140	5700	5.99	11	PASS





A D T

### Test Mode B1 (Without MSR & Main Ant.)

#### 802.11a

CHANNEL	FREQUENCY (MHz)	PSD (dBm)	MAXIMUM LIMIT (dBm)	PASS/FAIL
36	5180	3.79	4	PASS
40	5200	3.69	4	PASS
48	5240	3.79	4	PASS
52	5260	8.41	11	PASS
60	5300	8.40	11	PASS
64	5320	8.50	11	PASS
100	5500	7.09	11	PASS
116	5580	8.61	11	PASS
140	5700	6.87	11	PASS

#### 802.11n (20MHz)

CHANNEL	FREQUENCY (MHz)	PSD (dBm)	MAXIMUM LIMIT (dBm)	PASS/FAIL
36	5180	3.58	4	PASS
40	5200	3.57	4	PASS
48	5240	3.59	4	PASS
52	5260	7.95	11	PASS
60	5300	7.89	11	PASS
64	5320	7.98	11	PASS
100	5500	7.47	11	PASS
116	5580	7.96	11	PASS
140	5700	6.43	11	PASS



A D T

### Test Mode C1 (Without MSR & Aux Ant.)

#### 802.11a

CHANNEL	FREQUENCY (MHz)	PSD (dBm)	MAXIMUM LIMIT (dBm)	PASS/FAIL
36	5180	3.63	4	PASS
40	5200	3.83	4	PASS
48	5240	3.85	4	PASS
52	5260	8.97	11	PASS
60	5300	9.04	11	PASS
64	5320	9.16	11	PASS
100	5500	7.37	11	PASS
116	5580	9.12	11	PASS
140	5700	6.06	11	PASS

#### 802.11n (20MHz)

CHANNEL	FREQUENCY (MHz)	PSD (dBm)	MAXIMUM LIMIT (dBm)	PASS/FAIL
36	5180	3.48	4	PASS
40	5200	3.37	4	PASS
48	5240	3.51	4	PASS
52	5260	7.92	11	PASS
60	5300	8.00	11	PASS
64	5320	8.08	11	PASS
100	5500	7.22	11	PASS
116	5580	8.08	11	PASS
140	5700	5.96	11	PASS

## 4.5 PEAK POWER EXCURSION MEASUREMENT

### 4.5.1 LIMITS OF PEAK POWER EXCURSION MEASUREMENT

Shall not exceed 13 dB.

### 4.5.2 TEST SETUP

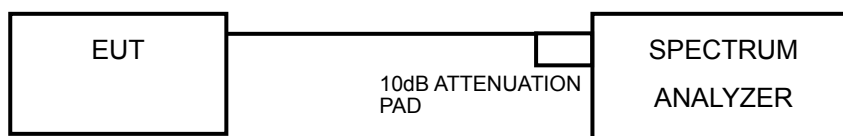

### 4.5.3 TEST INSTRUMENTS

Refer to section 4.1.3 to get information of above instrument.

### 4.5.4 TEST PROCEDURE

- 1) Set RBW = 1 MHz, VBW  $\geq$  3 MHz, Detector = peak.
- 2) Trace mode = max-hold. Allow the sweeps to continue until the trace stabilizes.
- 3) Use the peak search function to find the peak of the spectrum.
- 4) Measure the PPSD.
- 5) Compute the ratio of the maximum of the peak-max-hold spectrum to the PPSD.

### 4.5.5 DEVIATION FROM TEST STANDARD

No deviation.

### 4.5.6 EUT OPERATING CONDITIONS

Same as 4.2.6



A D T

### 4.5.7 TEST RESULTS

#### Test Mode A1 (With MSR& Main Ant.)

802.11a

CHANNEL	CHANNEL FREQUENCY (MHz)	PEAK VALUE (dBm)	PPSD (dBm)	PEAK EXCURSION (dB)	LIMIT (dB)	PASS/FAIL
36	5180	12.85	3.66	9.19	13	PASS
40	5200	12.55	3.43	9.12	13	PASS
48	5240	12.94	3.69	9.25	13	PASS
52	5260	17.74	8.56	9.18	13	PASS
60	5300	17.49	8.06	9.43	13	PASS
64	5320	17.95	8.60	9.35	13	PASS
100	5500	15.99	6.88	9.11	13	PASS
116	5580	17.96	8.42	9.54	13	PASS
140	5700	15.37	6.18	9.19	13	PASS

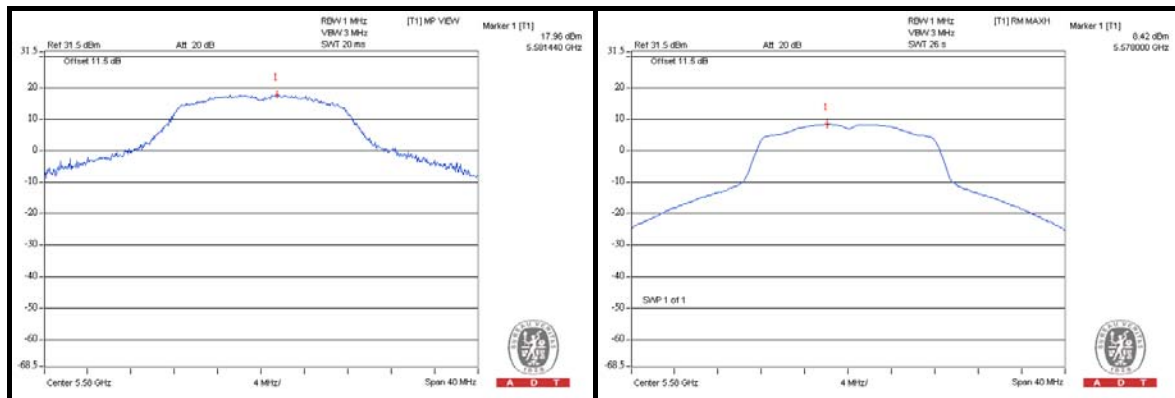



A D T

### 802.11n (20MHz)

CHANNEL	CHANNEL FREQUENCY (MHz)	PEAK VALUE (dBm)	PPSD (dBm)	PEAK EXCURSION (dB)	LIMIT (dB)	PASS/FAIL
36	5180	12.12	3.33	8.79	13	PASS
40	5200	12.29	3.50	8.79	13	PASS
48	5240	12.22	3.62	8.60	13	PASS
52	5260	17.24	8.19	9.05	13	PASS
60	5300	16.94	7.88	9.06	13	PASS
64	5320	16.39	7.52	8.87	13	PASS
100	5500	15.35	6.65	8.70	13	PASS
116	5580	16.61	7.56	9.05	13	PASS
140	5700	15.31	5.99	9.32	13	PASS

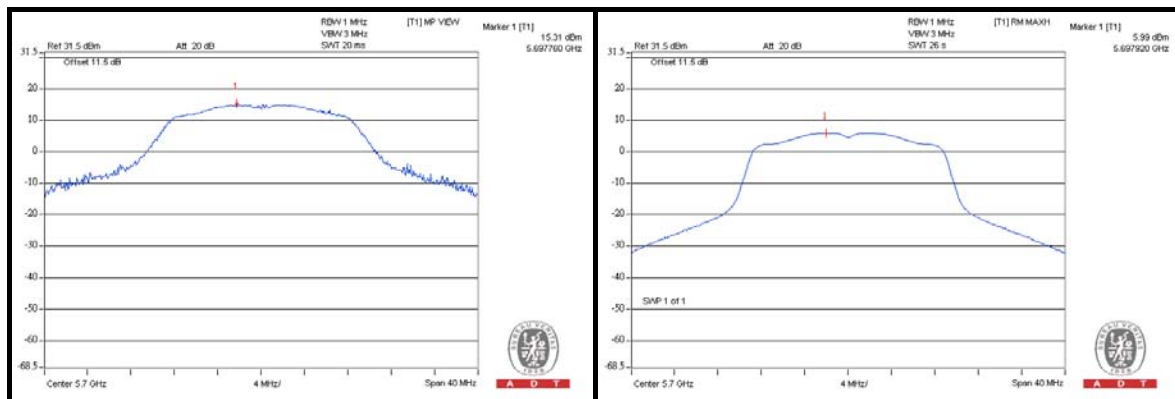



A D T

### Test Mode B1 (Without MSR & Main Ant.)

802.11a

CHANNEL	CHANNEL FREQUENCY (MHz)	PEAK VALUE (dBm)	PPSD (dBm)	PEAK EXCURSION (dB)	LIMIT (dB)	PASS/FAIL
36	5180	12.59	3.79	8.80	13	PASS
40	5200	12.86	3.69	9.17	13	PASS
48	5240	12.84	3.76	9.08	13	PASS
52	5260	17.45	8.41	9.04	13	PASS
60	5300	17.49	8.40	9.09	13	PASS
64	5320	17.55	8.50	9.05	13	PASS
100	5500	15.87	7.09	8.78	13	PASS
116	5580	17.69	8.61	9.08	13	PASS
140	5700	15.58	6.87	8.71	13	PASS

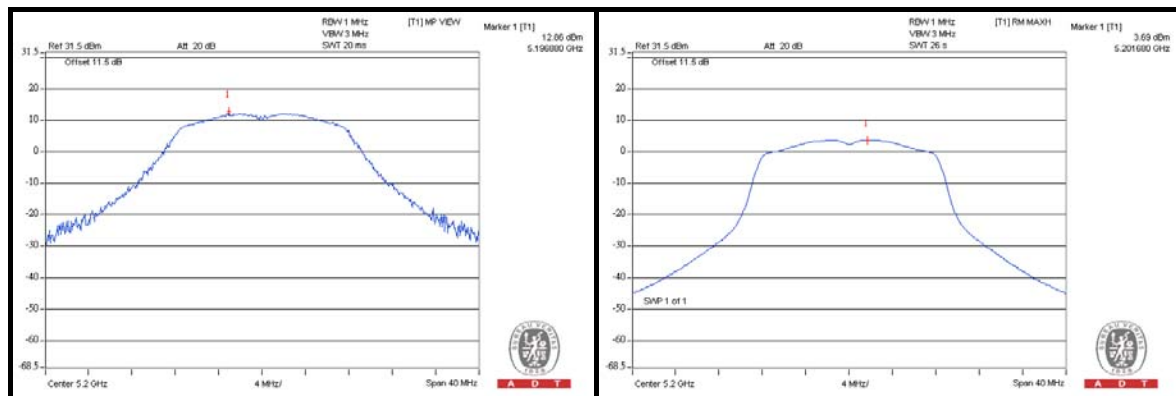



A D T

### 802.11n (20MHz)

CHANNEL	CHANNEL FREQUENCY (MHz)	PEAK VALUE (dBm)	PPSD (dBm)	PEAK EXCURSION (dB)	LIMIT (dB)	PASS/FAIL
36	5180	12.16	3.58	8.58	13	PASS
40	5200	12.74	3.57	9.17	13	PASS
48	5240	12.52	3.59	8.93	13	PASS
52	5260	17.23	7.95	9.28	13	PASS
60	5300	16.83	7.89	8.94	13	PASS
64	5320	17.21	7.98	9.23	13	PASS
100	5500	16.29	7.47	8.82	13	PASS
116	5580	16.81	7.96	8.85	13	PASS
140	5700	15.96	6.43	9.53	13	PASS

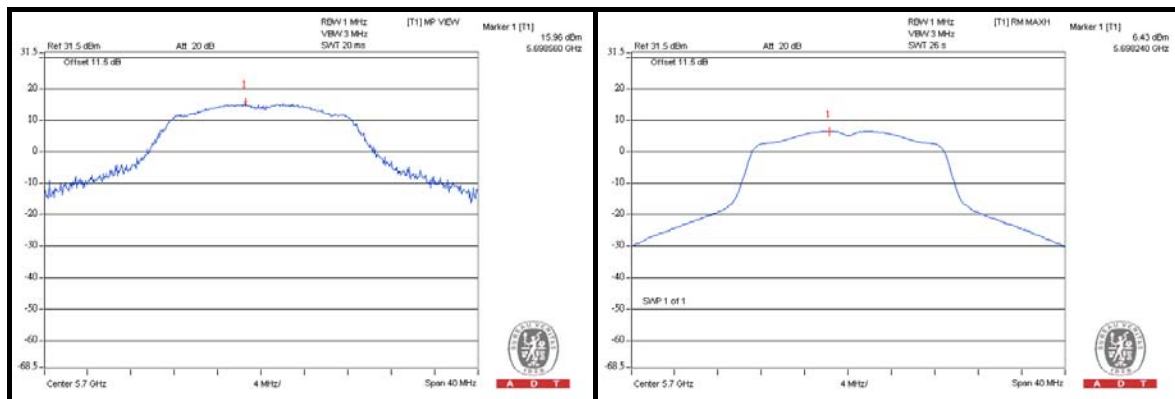



A D T

### Test Mode C1 (Without MSR & Aux Ant.)

802.11a

CHANNEL	CHANNEL FREQUENCY (MHz)	PEAK VALUE (dBm)	PPSD (dBm)	PEAK EXCURSION (dB)	LIMIT (dB)	PASS/FAIL
36	5180	12.95	3.63	9.32	13	PASS
40	5200	13.18	3.83	9.35	13	PASS
48	5240	12.87	3.85	9.02	13	PASS
52	5260	18.13	8.97	9.16	13	PASS
60	5300	18.44	9.04	9.40	13	PASS
64	5320	18.29	9.16	9.13	13	PASS
100	5500	16.08	7.37	8.71	13	PASS
116	5580	18.13	9.12	9.01	13	PASS
140	5700	14.95	6.06	8.89	13	PASS

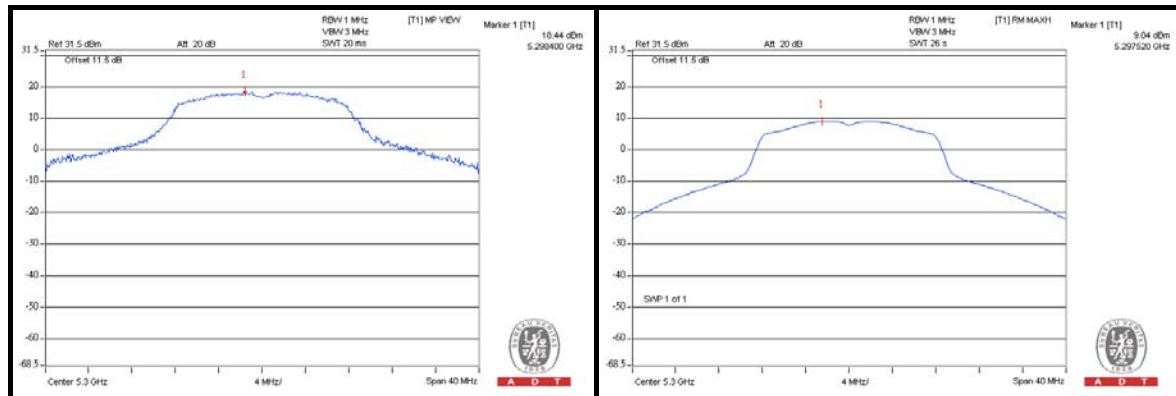





A D T

802.11n (20MHz)

CHANNEL	CHANNEL FREQUENCY (MHz)	PEAK VALUE (dBm)	PPSD (dBm)	PEAK EXCURSION (dB)	LIMIT (dB)	PASS/FAIL
36	5180	12.81	3.48	9.33	13	PASS
40	5200	12.27	3.37	8.90	13	PASS
48	5240	12.01	3.51	8.50	13	PASS
52	5260	17.05	7.92	9.13	13	PASS
60	5300	17.04	8.00	9.04	13	PASS
64	5320	17.02	8.08	8.94	13	PASS
100	5500	16.12	7.22	8.90	13	PASS
116	5580	16.91	8.08	8.83	13	PASS
140	5700	14.76	5.96	8.80	13	PASS

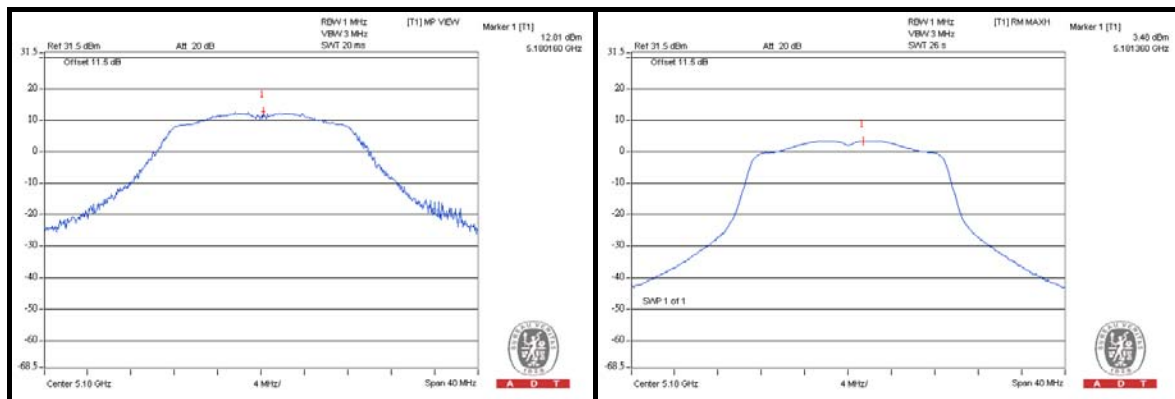

## 4.6 FREQUENCY STABILITY

### 4.6.1 LIMITS OF FREQUENCY STABILITY MEASUREMENT

The frequency of the carrier signal shall be maintained within band of operation

### 4.6.2 TEST SETUP

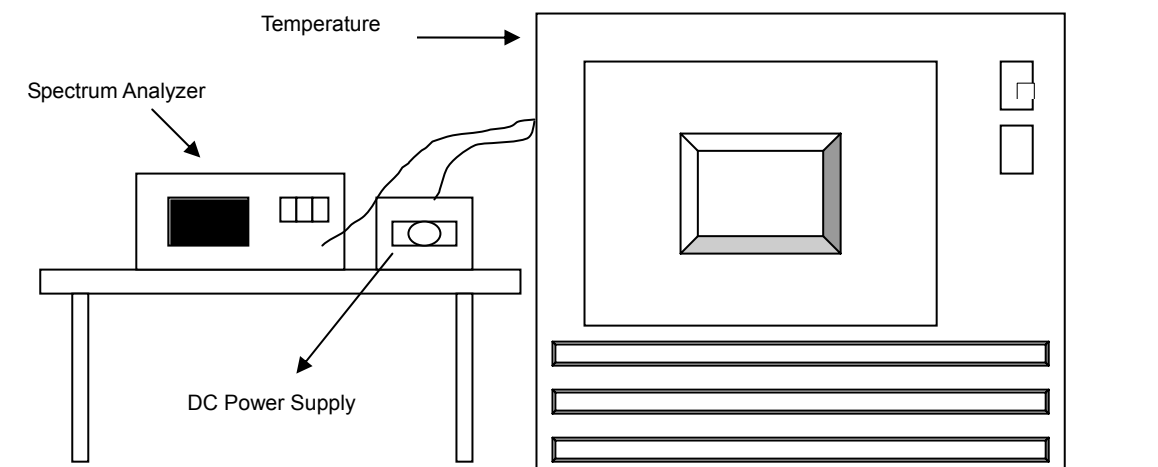

### 4.6.3 TEST INSTRUMENTS

Refer to section 4.1.3 to get information of above instrument.

#### 4.6.4 TEST PROCEDURE

- a. The EUT was placed inside the environmental test chamber and powered by nominal DC voltage.
- b. Turn the EUT on and couple its output to a spectrum analyzer.
- c. Turn the EUT off and set the chamber to the highest temperature specified.
- d. Allow sufficient time (approximately 30 min) for the temperature of the chamber to stabilize, turn the EUT on and measure the operating frequency after 2, 5, and 10 minutes.
- e. Repeat step 2 and 3 with the temperature chamber set to the lowest temperature.
- f. The test chamber was allowed to stabilize at +20 degree C for a minimum of 30 minutes. The supply voltage was then adjusted on the EUT from 85% to 115% and the frequency record.

#### 4.6.5 DEVIATION FROM TEST STANDARD

No deviation.

#### 4.6.6 EUT OPERATING CONDITION

Set the EUT transmit at un-modulation mode to test frequency stability.

#### 4.6.7 TEST RESULTS

##### Test Mode A1 (With MSR& Main Ant.)

FREQUENCY STABILITY VERSUS TEMP.									
OPERATING FREQUENCY: 5320MHz									
TEMP. (°C)	POWER SUPPLY (Vdc)	0 MINUTE		2 MINUTE		5 MINUTE		10 MINUTE	
		Measured Frequency (MHz)	Frequency Drift (ppm)	Measured Frequency (MHz)	Frequency Drift (ppm)	Measured Frequency (MHz)	Frequency Drift (ppm)	Measured Frequency (MHz)	Frequency Drift (ppm)
55	3.7	5320.018316	3.443	5320.018533	3.484	5320.018703	3.516	5320.018367	3.452
50	3.7	5320.018284	3.437	5320.018604	3.497	5320.018957	3.563	5320.018402	3.459
40	3.7	5320.019968	3.753	5320.019525	3.670	5320.019479	3.661	5320.019422	3.651
30	3.7	5320.020940	3.936	5320.021471	4.036	5320.021066	3.960	5320.020989	3.945
20	3.7	5320.021075	3.961	5320.021386	4.020	5320.020929	3.934	5320.021030	3.953
10	3.7	5320.022199	4.173	5320.021528	4.047	5320.022101	4.154	5320.021487	4.039
0	3.7	5320.019952	3.750	5320.019877	3.736	5320.019808	3.723	5320.020140	3.786
-10	3.7	5320.019339	3.635	5320.019444	3.655	5320.019230	3.615	5320.019037	3.578
-20	3.7	5320.018004	3.384	5320.018548	3.486	5320.018246	3.430	5320.018394	3.458
-30	3.7	5320.017875	3.360	5320.018288	3.438	5320.018513	3.480	5320.018172	3.416

FREQUENCY STABILITY VERSUS VOLTAGE									
OPERATING FREQUENCY: 5320MHz									
TEMP. (°C)	POWER SUPPLY (Vdc)	0 MINUTE		2 MINUTE		5 MINUTE		10 MINUTE	
		Measured Frequency (MHz)	Frequency Drift (ppm)	Measured Frequency (MHz)	Frequency Drift (ppm)	Measured Frequency (MHz)	Frequency Drift (ppm)	Measured Frequency (MHz)	Frequency Drift (ppm)
20	3.15	5320.020112	3.780	5320.019926	3.745	5320.020279	3.812	5320.019751	3.713
	3.70	5320.021075	3.961	5320.021386	4.020	5320.020929	3.934	5320.021030	3.953
	4.26	5320.023308	4.381	5320.023178	4.357	5320.023031	4.329	5320.023189	4.359

## 5. PHOTOGRAPHS OF THE TEST CONFIGURATION

Please refer to the attached file (Test Setup Photo).



## 6. INFORMATION ON THE TESTING LABORATORIES

We, Bureau Veritas Consumer Products Services (H.K.) Ltd., Taoyuan Branch, were founded in 1988 to provide our best service in EMC, Radio, Telecom and Safety consultation. Our laboratories are accredited and approved according to ISO/IEC 17025.

If you have any comments, please feel free to contact us at the following:

**Linko EMC/RF Lab:**

Tel: 886-2-26052180

Fax: 886-2-26051924

**Hsin Chu EMC/RF Lab:**

Tel: 886-3-5935343

Fax: 886-3-5935342

**Hwa Ya EMC/RF/Safety Telecom Lab:**

Tel: 886-3-3183232

Fax: 886-3-3270892

**Email:** [service.adt@tw.bureauveritas.com](mailto:service.adt@tw.bureauveritas.com)

**Web Site:** [www.bureauveritas-adt.com](http://www.bureauveritas-adt.com)

The address and road map of all our labs can be found in our web site also.

## 7. APPENDIX A - MODIFICATIONS RECORDERS FOR ENGINEERING CHANGES TO THE EUT BY THE LAB

No modifications were made to the EUT by the lab during the test.

---END---