

## MC33AX Regulatory Guide

### Regulatory Information

This device is approved under Zebra Technologies Corporation.

This guide applies to the following model number: MC330X

All Zebra devices are designed to be compliant with the rules and regulations in the locations they are sold and will be labeled as required.

Local language translation / Tradução do idioma local / Übersetzung in die lokale Sprache / Raduccion de idioma local / Traduzione en langue locale / Prijevod na lokalni jezik / Traduzione en lingua locale / 現地語の翻訳 / 현지 언어 번역 / Перевод на местный язык / 本地語言翻譯 / 本地語言翻譯 / Yerel dil çeviri / Tłumaczenie na język lokalny: [zebra.com/support](http://zebra.com/support)

Any changes or modifications to Zebra equipment not expressly approved by Zebra could void the user's authority to operate the equipment.

Declared maximum operating temperature: 50°C

For use only with Zebra approved and UL Listed mobile devices, Zebra approved, and UL Listed/Recognized battery packs.

### Bluetooth® Wireless Technology

This is an approved Bluetooth® product. For more information on the Bluetooth SIG listing, please visit [bluetooth.com](http://bluetooth.com).

### Regulatory Markings

Regulatory markings subject to certification are applied to the device signifying the radio(s) is/are approved for use. Refer to the Declaration of Conformity (DoC) for details of other country markings. The DoC is available at: [zebra.com/doc](http://zebra.com/doc).

The regulatory marks specific to this device (including FCC and ISED) are available on the screen of the device by following these instructions:

Go to **Settings > Regulatory**.

### Health and Safety Recommendations

#### Ergonomic Recommendations

In order to avoid or minimize the potential risk of ergonomic injury, always follow good ergonomic workplace practices. Consult with your local Health and Safety Manager to ensure that you are adhering to your company's safety programs to prevent employee injury.

#### Vehicle Installation

RF signals may affect improperly installed or inadequately shielded electronic systems in motor vehicles (including safety systems). Check with the manufacturer or its representative regarding your vehicle. Ensure the equipment is installed to avoid driver distractions. You should also consult the manufacturer about any equipment that has been added to your vehicle.

Position the device within easy reach. User should be able to access the device without removing their eyes from the road.

**IMPORTANT:** Before installing or using, check national and local laws regarding distracted driving.

#### Safety on the Road

Give your full attention to driving. Obey the laws and regulations on the use of wireless devices in the areas where you drive.

The wireless industry reminds you to use your device / phone safely when driving.

#### Restricted Use Locations

Remember to observe restrictions and obey all signs and instructions on the use of electronic devices in restricted use locations.

### Safety in Hospitals and Aircraft



**NOTE:** Wireless devices transmit radio frequency energy that may affect medical electrical equipment and aircraft's operation. Wireless devices should be switched off wherever you are requested to do so in

hospitals, clinics, healthcare facilities or by airline staff. These requests are designed to prevent possible interference with sensitive equipments.

### RF Exposure Guidelines

#### Safety Information

#### Reducing RF Exposure – Use Properly

Only operate the device in accordance with the instructions supplied.

The device complies with internationally recognized standards covering human exposure to electromagnetic fields. For information on international human exposure to electromagnetic fields, refer to the Zebra Declaration of Conformity (DoC) at [zebra.com/doc](http://zebra.com/doc).

Use only Zebra tested and approved headset, belt-clips, holsters, and similar accessories to ensure RF exposure compliance. If applicable, follow the instructions for use as detailed in the accessory guide.

The use of third-party belt clips, holsters, and similar accessories may not comply with RF exposure compliance requirements and should be avoided.

For further information on the safety of RF energy from wireless devices, refer to RF exposure and assessment standards section at [zebra.com/responsibility](http://zebra.com/responsibility).

To satisfy RF exposure requirements, this device must be hand-use only and, where applicable use only with Zebra tested and approved accessories.

#### Laser Devices

Class 2 laser scanners use a low power, visible light diode. As with any very bright light source such as the sun, the user should avoid staring directly into the light beam. Momentary exposure to a Class 2 laser is not known to be harmful.



**CAUTION:** Use of controls, adjustments, or the performance of procedures other than those specified in the supplied product documentation may result in hazardous laser light exposure.

### Scanner Labeling

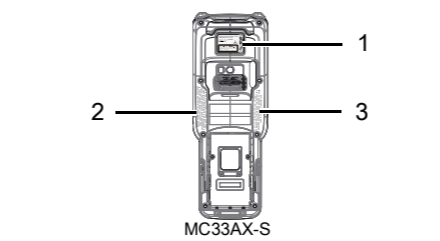
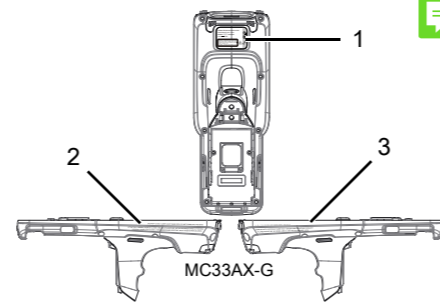

Labels read:

1. Laser Light — do not stare into beam Class 2 Laser product. 630-680mm, 1mW
2. Caution — Class 3R laser light when open. Avoid direct eye exposure.
3. Complies with 21 CFR1040.10 and 1040.11 except for deviations pursuant to Laser Notice No. 56, DATED May 08, 2019 and IEC/EN 60825-1:2014.

### LED Devices

Classified as 'EXEMPT RISK GROUP' according to IEC 62471:2006 and EN 62471:2008.

Pulse Duration: 4 ms (MC330X with SE4770)

Pulse Duration: CW (MC330X with SE4850)

### Power Supply



**WARNING ELECTRICAL SHOCK:** Use only a Zebra approved, Certified ITE [LPS] power supply with appropriate electrical ratings. Use of alternative power supply will invalidate any approvals given to this unit and may be dangerous.

### Batteries and Power Packs

This information applies to Zebra-approved batteries and power packs containing batteries.

### Battery Information

**CAUTION:** Risk of explosion if battery is replaced by an incorrect type. Dispose of batteries according to instructions.

Use only Zebra approved batteries.

Accessories which have battery charging capability are approved for use with the following battery models:

- Model BT-000375 (3.6 VDC, 7000 mAh)
- Model BT-000444 (3.6 VDC, 7000 mAh)

Zebra approved rechargeable battery packs are designed and constructed to the highest standards within the industry.

However, there are limitations as to how long a battery can operate or be stored before needing replacement. Many factors affect the actual life cycle of a battery pack such as heat, cold, harsh environmental conditions, and severe drops.

When batteries are stored over six months, some irreversible deterioration in overall battery quality may occur. Store batteries at half charge in a dry, cool place, removed from the equipment to prevent loss of capacity, rusting of metallic parts, and electrolyte leakage. When storing batteries for one year or longer, the charge level should be verified at least once a year and charged to half charge.

Replace the battery when a significant loss of run time is detected.

- Standard warranty period for all Zebra batteries is one year, regardless if the battery was purchased separately or included as part of the host device. For more information on Zebra batteries, please visit: [zebra.com/batterydocumentation](http://zebra.com/batterydocumentation) and select the Battery Best Practices link.

### Battery Safety Guidelines

**IMPORTANT – SAFETY INSTRUCTIONS – SAVE THESE INSTRUCTIONS**



**WARNING –** When using this product basic safety precautions should always be followed, including the following:

- The area in which the units are charged should be clear of debris and combustible materials or chemicals. Particular care should be taken where the device is charged in a non-commercial environment.
- Read all the instructions before using the product.
- Follow battery usage, storage, and charging guidelines found in the user's guide.
- Improper battery use may result in a fire, explosion, or other hazard.

To charge the mobile device battery, the battery and charger temperatures must be between 0°C and +40°C (+32°F and +104°F).

Do not use incompatible batteries and chargers. Use of an incompatible battery or charger may present a risk of fire, explosion, leakage, or other hazard. If you have any questions about the compatibility of a battery or a charger, contact Zebra support.

Do not disassemble or open, crush, bend or deform, puncture, or shred. Damaged or modified batteries may exhibit unpredictable behavior resulting in fire, explosion, or risk of injury.

Severe impact from dropping any battery-operated device on a hard surface could cause the battery to overheat.

Do not short circuit a battery or allow metallic or conductive objects to contact the battery terminals.

Do not modify, disassemble, or remanufacture, attempt to insert foreign objects into the battery, immerse or expose to water, rain, snow or other liquids, or expose to fire, explosion, or other hazard.

Do not leave or store the equipment in or near areas that might get very hot, such as in a parked vehicle or near a radiator or other heat source. Do not place battery into a microwave oven or dryer.

To reduce the risk of injury, close supervision is necessary when used near children.

Please follow local regulations to promptly dispose of used re-chargeable batteries.

Do not dispose of batteries in fire. Exposure to temperatures over 100°C (212°F) may cause explosion. Seek medical advice immediately if a battery has been swallowed.

In the event of a battery leak, do not allow the liquid to come in contact with the skin or eyes. If contact has been made, wash the affected area with large amounts of water and seek medical advice.

If you suspect damage to your equipment or battery, contact Zebra support to arrange for inspection.

### CE Marking and European Economic Area (EEA)

**Statement of Compliance**  
Zebra hereby declares that this radio equipment is in compliance with Directives 2014/53/EU and 2011/65/EU.

Any radio operation limitations within EEA countries are identified in Appendix A of EU Declaration of Conformity. The full text of the EU Declaration of Conformity is available at: [zebra.com/doc](http://zebra.com/doc).

EU Importer: Zebra Technologies B.V  
Address: Mercurius 12, 8448 GX Heerenveen, Netherlands

### Waste Electrical and Electronic Equipment (WEEE)

For EU and UK Customers: For products at the end of their life, please refer to recycling/disposal advice at: [zebra.com/weee](http://zebra.com/weee).

### United States and Canada Regulatory

#### Radio Frequency Interference Notices

This device complies with Part 15 of the FCC Rules. Operation is subject to the following two conditions: (1) this device may not cause harmful interference, and (2) this device must accept any interference received including interference that may cause undesired operation.



**NOTE:** This equipment has been tested and found to comply with the limits for a Class B digital device, pursuant to Part 15 of the FCC rules. These limits are designed to provide reasonable protection against harmful

interference in a residential installation. This equipment generates, uses and can radiate radio frequency energy and, if not installed and used in accordance with the instructions, may cause harmful interference to radio communications. However, there is no guarantee that interference will not occur in a particular installation. If this equipment does cause harmful interference to radio or television reception, which can be determined by turning the equipment off and on, the user is encouraged to try to correct the interference by one or more of the following measures:

- Reorient or relocate the receiving antenna.
- Increase the separation between the equipment and receiver.
- Connect the equipment into an outlet on a circuit different from that to which the receiver is connected.
- Consult the dealer or an experienced radio/TV technician for help.

### Radio Frequency Interference Requirements – Canada

Innovation, Science and Economic Development Canada ICES-003 Compliance Label: CAN ICES-3 (B1)/NMB-3(B1)

This device complies with Innovation, Science and Economic Development Canada's licence-exempt RSSs. Operation is subject to the following two conditions: (1) This device may not cause interference; and (2) This device must accept any interference, including interference that may cause undesired operation of the device.

L'émetteur/récepteur exempt de licence contenu dans le présent appareil est conforme aux CNR d'Innovation, Sciences et Développement économique Canada applicables aux appareils radio exempts de licence. L'exploitation est autorisée aux deux conditions suivantes : (1) l'appareil ne doit pas produire de brouillage, et (2) l'utilisateur de l'appareil doit accepter tout brouillage radio électrique subi même si le brouillage est susceptible d'en compromettre le fonctionnement.

This device is restricted to indoor use when operating in the 5150 to 5350 MHz frequency range.

Lorsqu'il fonctionne dans la plage de fréquences 5 150- 5350 MHz, cet appareil doit être utilisé exclusivement en extérieur.

### RF Exposure Requirements - FCC and ISED

The FCC has granted an Equipment Authorization for this device with all reported SAR levels evaluated in compliance with the FCC RF emission guidelines. SAR information on this device is on file with the FCC and can be found under the Display Grant section of [fcc.gov/oet/ea/fccid](http://fcc.gov/oet/ea/fccid).

To satisfy RF exposure requirements, this device must be hand-held only and, where applicable use only with Zebra tested and approved accessories.

Pour satisfaire aux exigences d'exposition aux RF, cet appareil doit être cheville utilisé manuellement uniquement, le cas échéant, uniquement utilisé avec les accessoires approuvés et testés par Zebra.



MN-004159-01EN-P — 04/2021

Zebra Technologies | 3 Overlook Point |  
Lincolnshire, IL 60069 USA  
[zebra.com](http://zebra.com)

ZEBRA and the stylized Zebra head are trademarks of Zebra Technologies Corp., registered in many jurisdictions worldwide. All other trademarks are the property of their respective owners. © 2021 Zebra Technologies Corp. and/or its affiliates. All rights reserved.



**Co-located Statement**

To comply with FCC RF exposure compliance requirement, the antenna used for this transmitter must not be co-located (within 20 cm) or operating in conjunction with any other transmitter/antenna except those already approved in this filing.

**中国**

通过访问以下网址可下载当地语言支持的产品说明书 [zebra.com/support](http://zebra.com/support)

如果配套使用外部电源适配器，请确保其已通过 CCC 认证

(一) 符合“微功率短距离无线电发射设备目录和技术要求”的具体条款和使用场景，采用的天线类型和性能，控制、调整及开关等使用方法；

(二) 不得擅自改变使用场景或使用条件、扩大发射频率范围、加大发射功率（包括额外加装射频功率放大器），不得擅自更改发射天线；

(三) 不得对其他合法的无线电台（站）产生有害干扰，也不得提出免受有害干扰保护；

(四) 应当承受辐射射频能量的工业、科学及医疗（ISM）应用设备的干扰或其他合法的无线电台（站）干扰；

(五) 如对其他合法的无线电台（站）产生有害干扰时，应立即停止使用，并采取消除措施后方可继续使用；

(六) 在航空器内和依据法律法规、国家有关规定、标准划设的射电天文台、气象雷达站、卫星地球站（含测控、测距、接收、导航站）等军民用无线电台（站）、机场等的电磁环境保护区域内使用微功率设备，应当遵守电磁环境保护及相关行业主管部门的规定；

(七) 禁止在以机场跑道中心点为圆心、半径 5000 米的区域内使用各类模型遥控器；

(八) 有关支持的工作环境条件，请参阅本指南的最高工作温度以及电池信息和电源信息部分。



**产品中有害物质的名称及含量**

部件名称 (Parts)	有害物质					
	铅 (Pb)	汞 (Hg)	镉 (Cd)	六价铬 (Cr(VI))	多溴联苯 (PBB)	多溴二苯醚 (PBDE)
金属部件 (Metal Parts)						
电路模块 (Circuit Modules)						
电缆及电缆组件 (Cables and Cable Assemblies)						
塑料和聚合物部件 (Plastic and Polymeric Parts)						
光学和光学组件 (Optics and Optical Components)						
打印头 (Print Heads)						
电池 (Batteries)						
外部电源 (Ext. Pwr Sply)						
本表格依据 SJ/T 11364 的规定编制。 O: 表示该有害物质在该部件所有均质材料中的含量均在 SJ/T 11364-2014 规定的限量要求以下。 X: 表示该有害物质至少在该部件的某一均质材料中的含量超出 SJ/T 11364-2014 规定的限量要求。(企业可在此处，根据实际情况对上表中打“X”的技术原因进行进一步说明。						

**Евразийский Таможенный Союз (EAC)**

Данный продукт соответствует требованиям знака EAC.



**France**

Cet appareil a été testé et déclaré conforme aux limites applicables d'exposition aux radiofréquences (RF).

Le débit d'absorption spécifique (DAS) local quantifie l'exposition de l'utilisateur aux ondes électromagnétiques de l'équipement concerné.

Les valeurs DAS les plus élevées sont disponibles sur la déclaration de conformité (DoC) disponible sur: [zebra.com/doc](http://zebra.com/doc).

**México**

La operación de este equipo está sujeta a las siguientes dos condiciones: (1) es posible que este equipo o dispositivo no cause interferencia perjudicial y (2) este equipo o dispositivo debe aceptar cualquier interferencia, incluyendo la que pueda causar su operación no deseada.

**臺灣**

低功率電波輻射性電機管理辦法

取得審驗證明之低功率射頻器材，非經核准，公司、商號或使用者均不得擅自變更頻率、加大功率或變更原設計之特性及功能。

低功率射頻器材之使用不得影響飛航安全及干擾合法通信；經發現有干擾現象時，應立即停用，並改善至無干擾時方得繼續使用。

前述合法通信，指依電信管理法規定作業之無線電通信。低功率射頻器材須忍受合法通信或工業、科學及醫療用電波輻射性電機設備之干擾。

應避免影響附近雷達系統之操作

公司資訊

台灣斑馬科技股份有限公司 / 台北市信義區松高路 9 號 13 樓



「廢電池請回收」

行政院環保署 (EPA) 要求乾電池製造或進口商，需依廢棄物清理法第 15 條之規定，於販售、贈送或促銷的電池上標示回收標誌。請聯絡合格的台灣回收廠商，以正確棄置電池。

**限用物質含有情況標示聲明書**

設備名稱	型號 (型式) MC330X					
	限用物質及其化學符號					
單元	鉛 (Pb)	汞 (Hg)	鎘 (Cd)	六價鉻 (Cr(VI))	多溴聯苯 (PBB)	多溴二苯醚 (PBDE)
印刷電路板及電子組件						
金屬零件						
電纜及電纜組件						
塑料和聚合物零件						
光學與光學元件						
打印頭						
備考1. “超出0.1 wt %”及“超出0.01 wt %”係指限用物質之百分比含量超出百分比含量基準值。 備考2. “O”係指該項限用物質之百分比含量未超出百分比含量基準值。 備考3. “-”係指該項限用物質為排除項目。 Note 1: “Exceeding 0.1 wt%” and “exceeding 0.01 wt%” indicate that the percentage content of the restricted substance exceeds the reference percentage value of presence condition. Note 2: “O” indicates that the percentage content of the restricted substance does not exceed the percentage of reference value of presence. Note 3: The “-” indicates that the restricted substance corresponds to the exemption.						

**TÜRK WEEE Uyumluluk Beyanı**  
EEE Yönetmeliğine Uygundur.

**UK CA United Kingdom**

**Statement of Compliance**  
Zebra hereby declares that this radio equipment is in compliance with the Radio Equipment Regulations 2017 and the Restriction of the Use of Certain Hazardous Substances in Electrical and Electronic Equipment Regulations 2012.

Any radio operation limitations within UK are identified in Appendix A of UK Declaration of Conformity.

The full text of the UK Declaration of Conformity is available at: [zebra.com/doc](http://zebra.com/doc).

UK Importer: Zebra Technologies Europe Limited  
Address: Dukes Meadow, Millboard Rd, Bourne End, Buckinghamshire, SL8 5XF

**Warranty**

For the complete Zebra hardware product warranty statement, go to: [zebra.com/warranty](http://zebra.com/warranty).

**Service Information**

Before you use the unit, it must be configured to operate in your facility's network and run your applications.

If you have a problem running your unit or using your equipment, contact your facility's Technical or System Support. If there is a problem with the equipment, they will contact Zebra support at [zebra.com/support](http://zebra.com/support).

For the latest version of the guide go to: [zebra.com/support](http://zebra.com/support).

**Additional Information**

For information on using the MC33AX, refer to the MC33AX product guide available at: [zebra.com/mc33ax](http://zebra.com/mc33ax).



Draft 3