



FCC RF Test Report

APPLICANT : Zebra Technologies Corporation
EQUIPMENT : Mobile Computer
BRAND NAME : Zebra
MODEL NAME : MC330M
FCC ID : UZ7MC330M
STANDARD : FCC Part 15 Subpart C §15.247
CLASSIFICATION : (DTS) Digital Transmission System

This is a variant report which is only valid together with the original test report. The product was received on Sep. 02, 2017 and testing was completed on Oct. 17, 2017. We, SPORTON INTERNATIONAL INC., would like to declare that the tested sample has been evaluated in accordance with the test procedures and has been in compliance with the applicable technical standards.

The test results in this report apply exclusively to the tested model / sample. Without written approval of SPORTON INTERNATIONAL INC., the test report shall not be reproduced except in full.

Reviewed by: Joseph Lin / Supervisor

Approved by: Jones Tsai / Manager



SPORTON INTERNATIONAL INC.

No. 52, Hwa Ya 1st Rd., Hwa Ya Technology Park, Kwei-Shan District, Tao Yuan City, Taiwan, R.O.C.

SPORTON INTERNATIONAL INC.

TEL : 886-3-327-3456

FAX : 886-3-328-4978

FCC ID : UZ7MC330M

Page Number : 1 of 35

Report Issued Date : Nov. 08, 2017

Report Version : Rev. 02

Report Template No.: BU5-FR15CWLAC MA Version 2.0



TABLE OF CONTENTS

REVISION HISTORY..... 3

SUMMARY OF TEST RESULT 4

1 GENERAL DESCRIPTION 5

 1.1 Applicant 5

 1.2 Manufacturer 5

 1.3 Product Feature of Equipment Under Test..... 5

 1.4 Product Specification of Equipment Under Test..... 7

 1.5 Modification of EUT 7

 1.6 Testing Location 8

 1.7 Applicable Standards..... 8

2 TEST CONFIGURATION OF EQUIPMENT UNDER TEST 9

 2.1 Carrier Frequency and Channel 9

 2.2 Test Mode 10

 2.3 Connection Diagram of Test System 18

 2.4 Support Unit used in test configuration and system 19

 2.5 EUT Operation Test Setup 19

3 TEST RESULT 20

 3.1 Output Power Measurement..... 20

 3.2 Radiated Band Edges and Spurious Emission Measurement 27

 3.3 Antenna Requirements 32

4 LIST OF MEASURING EQUIPMENT 34

5 UNCERTAINTY OF EVALUATION 35

APPENDIX A. RADIATED SPURIOUS EMISSION

APPENDIX B. RADIATED SPURIOUS EMISSION PLOTS

APPENDIX C. DUTY CYCLE PLOTS

APPENDIX D. SETUP PHOTOGRAPHS



SUMMARY OF TEST RESULT

Report Section	FCC Rule	Description	Limit	Result	Remark
-	15.247(a)(2)	6dB Bandwidth	≥ 0.5MHz	Not Required	-
-	-	99% Bandwidth	-	Not Required	-
3.1	15.247(b)	Power Output Measurement	≤ 30dBm	Pass	-
-	15.247(e)	Power Spectral Density	≤ 8dBm/3kHz	Not Required	-
-	15.247(d)	Conducted Band Edges	≤ 20dBc	Not Required	-
		Conducted Spurious Emission		Not Required	-
3.2	15.247(d)	Radiated Band Edges and Radiated Spurious Emission	15.209(a) & 15.247(d)	Pass	Under limit 1.01 dB at 2398.800 MHz and 2389.940 MHz
-	15.207	AC Conducted Emission	15.207(a)	Not Required	-
3.3	15.203 & 15.247(b)	Antenna Requirement	N/A	Pass	-

Note:

- Not required means after assessing, test items are not necessary to carry out.
- The original model (FCC ID: UZ7MC330K) and the variant model (FCC ID: UZ7MC330M) have identical PCB layout, antenna, SW implementation for Bluetooth/Wi-Fi. Based on their similarity, the test reports of FCC Part 15C & 15E (equipment class: DTS, DSS, NII) for the original model represent compliance for the variant model, and are referenced into the FCC filing of the variant model.
In this test report, performed conducted power measurement and BT/WLAN radiated spurious emission that based on the worst-case condition from the original model(FCC ID: UZ7MC330K) which can be referred to Sporton Report Number FR790120C.



1 General Description

1.1 Applicant

Zebra Technologies Corporation
1 Zebra Plaza, Holtsville, NY 11742

1.2 Manufacturer

Zebra Technologies Corporation
1 Zebra Plaza, Holtsville, NY 11742

1.3 Product Feature of Equipment Under Test

Product Feature	
Equipment	Mobile Computer
Brand Name	Zebra
Model Name	MC330M
FCC ID	UZ7MC330M
EUT supports Radios application	WLAN 11a/b/g/n HT20/HT40 WLAN 11ac VHT20/VHT40/VHT80 Bluetooth BR/EDR/LE
HW Version	EV1b
SW Version	Android Version 7.1.2
FW Version	W10: Aug 4 2017 12:57:11 version 7.35.205.8 (r) FWID 01-895bc792
Fusion Version	Fusion_BA_2.10.0.0.007_N-0809201717-N
MFD	30AUG17
EUT Stage	Engineering Sample

<SKU List>

Standard					
SKU	Type-scanner	camera	Audio Jack	NFC	Speaker
1	GUN-SE4850	X	X	X	X
2	GUN-SE4750	X	X	X	X
3	GUN-SE965	X	X	X	X
4	Brick-SE4850	X	X	X	X
5	Brick-SE4750	X	X	X	X
6	Brick-SE965	X	X	X	X
7	Rotate	X	X	X	X



Specification of Accessories				
Sentry 1X Battery	Brand Name	Zebra	Part Number	BT-000338-01
Sentry 2X Battery	Brand Name	Zebra	Part Number	BT-000337-01
MC32 1X Battery	Brand Name	Symbol	Part Number	82-000011-01
MC32 2X Battery	Brand Name	Symbol	Part Number	82-000012-02
Wall wart power supply(18W)	Brand Name	Zebra	Part Number	PWR-WUA5V12W0US
Charge Cable for Wall wart power supply	Brand Name	Zebra	Part Number	PWRS-14000-249R
HS2100 Earphone	Brand Name	Symbol	Part Number	HS2100-OTH
Quick Disconnect cable for HS2100 Headset	Brand Name	Symbol	Part Number	CBL-HS2100-QDC1-01
RCH51 Earphone	Brand Name	Symbol	Part Number	RCH51
Cable for RCH51 earphone	Brand Name	Symbol	Part Number	25-124411-02R
U cable	Brand Name	Symbol	Part Number	CBL-MC33-USBCHG-01
Gun Holster MC3000	Brand Name	Symbol	Model Name	SG-MC3021212-01R
Holster MC30XX	Brand Name	Symbol	Model Name	11-69293-01R



1.4 Product Specification of Equipment Under Test

Standards-related Product Specification													
Tx/Rx Channel Frequency Range	2412 MHz ~ 2462 MHz												
Maximum Average Output Power to antenna <CDD Mode>	<p><Ant. 1> 802.11b : 18.16 dBm (0.0655 W) 802.11g : 17.13 dBm (0.0516 W) 802.11n HT20 : 17.03 dBm (0.0505 W) 802.11n HT40 : 16.51 dBm (0.0448 W)</p> <p><Ant. 2> 802.11b : 18.18 dBm (0.0658 W) 802.11g : 17.23 dBm (0.0528 W) 802.11n HT20 : 17.19 dBm (0.0524 W) 802.11n HT40 : 16.99 dBm (0.0500 W)</p> <p><MIMO Ant. 1 + 2> 802.11b : 20.83 dBm (0.1211 W) 802.11g : 20.17 dBm (0.1040 W) 802.11n HT20 : 20.09 dBm (0.1021 W) 802.11n HT40 : 17.81 dBm (0.0604 W)</p>												
Maximum Average Output Power to antenna <TXBF Mode>	<p><MIMO Ant. 1 + 2> 802.11n HT20 : 21.46 dBm (0.1400 W) 802.11n HT40 : 19.56 dBm (0.0904 W)</p>												
Type of Modulation	802.11b : DSSS (DBPSK / DQPSK / CCK) 802.11g/n : OFDM (BPSK / QPSK / 16QAM / 64QAM)												
Antenna Type / Gain	<Ant. 1>PIFA Antenna with gain 3.86 dBi <Ant. 2>PIFA Antenna with gain 3.63 dBi												
Antenna Function Description	<table border="1"> <thead> <tr> <th></th> <th>Ant. 0</th> <th>Ant. 1</th> </tr> </thead> <tbody> <tr> <td>802.11 b/g/n</td> <td>V</td> <td>V</td> </tr> <tr> <td>802.11 b/g/n MIMO</td> <td>V</td> <td>V</td> </tr> <tr> <td>802.11 n TXBF</td> <td>V</td> <td>V</td> </tr> </tbody> </table>		Ant. 0	Ant. 1	802.11 b/g/n	V	V	802.11 b/g/n MIMO	V	V	802.11 n TXBF	V	V
	Ant. 0	Ant. 1											
802.11 b/g/n	V	V											
802.11 b/g/n MIMO	V	V											
802.11 n TXBF	V	V											

Note: MIMO Ant. 1+2 is a calculated result from sum of the power MIMO Ant. 1 and MIMO Ant. 2.

1.5 Modification of EUT

No modifications are made to the EUT during all test items.



1.6 Testing Location

Sporton Lab is accredited to ISO 17025 by Taiwan Accreditation Foundation (TAF code : 1190) and the FCC designation No. TW0007 under the FCC 2.948(e) by Mutual Recognition Agreement (MRA) in FCC Test.

Test Site	SPORTON INTERNATIONAL INC.
Test Site Location	No. 52, Hwa Ya 1 st Rd., Hwa Ya Technology Park, Kwei-Shan District, Tao Yuan City, Taiwan, R.O.C. TEL: +886-3-327-3456 FAX: +886-3-328-4978
Test Site No.	Sporton Site No. TH05-HY

Note: The test site complies with ANSI C63.4 2014 requirement.

Test Site	SPORTON INTERNATIONAL INC.
Test Site Location	No.58, Aly. 75, Ln. 564, Wenhua 3rd Rd. Guishan Dist, Taoyuan City, Taiwan (R.O.C.) TEL: +886-3-327-0868 FAX: +886-3-327-0855
Test Site No.	Sporton Site No. 03CH12-HY

Note: The test site complies with ANSI C63.4 2014 requirement.

1.7 Applicable Standards

According to the specifications of the manufacturer, the EUT must comply with the requirements of the following standards:

- ♦ FCC Part 15 Subpart C §15.247
- ♦ FCC KDB Publication No. 558074 D01 DTS Meas. Guidance v04
- ♦ FCC KDB 662911 D01 Multiple Transmitter Output v02r01.
- ♦ ANSI C63.10-2013

Remark:

1. All test items were verified and recorded according to the standards and without any deviation during the test.
2. This EUT has also been tested and complied with the requirements of FCC Part 15, Subpart B, recorded in a separate test report.



2 Test Configuration of Equipment Under Test

- a. The EUT has been associated with peripherals and configuration operated in a manner tended to maximize its emission characteristics in a typical application. Frequency range investigated: conduction emission (150 kHz to 30 MHz), radiation emission (9 kHz to the 10th harmonic of the highest fundamental frequency or to 40 GHz, whichever is lower). For radiated measurement, pre-scanned in three orthogonal panels, X, Y, Z. The worst cases (Y Plane) were recorded in this report.

- b. AC power line Conducted Emission was tested under maximum output power.

2.1 Carrier Frequency and Channel

Frequency Band	Channel	Freq. (MHz)	Channel	Freq. (MHz)
2400-2483.5 MHz	1	2412	7	2442
	2	2417	8	2447
	3	2422	9	2452
	4	2427	10	2457
	5	2432	11	2462
	6	2437		



2.2 Test Mode

Final test mode of conducted test items and radiated spurious emissions are considering the modulation and worse data rates as below table.

Single Antenna

Modulation	Data Rate
802.11b	1 Mbps
802.11g	6 Mbps
802.11n HT20	MCS0
802.11n HT40	MCS0

MIMO Antenna

Modulation	Data Rate
802.11b	1 Mbps
802.11g	6 Mbps
802.11n HT20	MCS0
802.11n HT40	MCS0

TXBF Antenna

Modulation	Data Rate
802.11n HT20	MCS0
802.11n HT40	MCS0



<CDD Modes>

<Ant. 1>

802.11b mode		
Power vs. Channel		
Channel	Frequency (MHz)	Data Rate (bps)
		1M
Duty Cycle (%)		100.00
CH 01	2412	18.10
CH 02	2417	18.12
CH 06	2437	18.16
CH 10	2457	18.13
CH 11	2462	18.10

802.11g mode		
Power vs. Channel		
Channel	Frequency (MHz)	Data Rate (bps)
		6M
Duty Cycle (%)		95.28
CH 01	2412	13.44
CH 02	2417	17.03
CH 06	2437	17.13
CH 10	2457	17.11
CH 11	2462	13.21

802.11n HT20 mode		
Power vs. Channel		
Channel	Frequency (MHz)	MCS Index
		MCS0
Duty Cycle (%)		95.83
CH 01	2412	11.15
CH 02	2417	17.00
CH 06	2437	17.03
CH 10	2457	17.00
CH 11	2462	12.13



802.11n HT40 mode		
Power vs. Channel		
Channel	Frequency (MHz)	MCS Index
		MCS0
Duty Cycle (%)		94.74
CH 03	2422	12.63
CH 06	2437	16.51
CH 09	2452	14.38



<Ant. 2>

802.11b mode		
Power vs. Channel		
Channel	Frequency (MHz)	Data Rate (bps)
		1M
Duty Cycle (%)		100.00
CH 01	2412	18.13
CH 02	2417	18.11
CH 06	2437	18.15
CH 10	2457	18.12
CH 11	2462	18.18

802.11g mode		
Power vs. Channel		
Channel	Frequency (MHz)	Data Rate (bps)
		6M
Duty Cycle (%)		96.06
CH 01	2412	13.03
CH 02	2417	17.23
CH 06	2437	17.07
CH 10	2457	17.13
CH 11	2462	13.20

802.11n HT20 mode		
Power vs. Channel		
Channel	Frequency (MHz)	MCS Index
		MCS0
Duty Cycle (%)		95.00
CH 01	2412	11.04
CH 02	2417	17.19
CH 06	2437	17.02
CH 10	2457	17.02
CH 11	2462	12.49



802.11n HT40 mode		
Power vs. Channel		
Channel	Frequency (MHz)	MCS Index
		MCS0
Duty Cycle (%)		94.74
CH 03	2422	12.53
CH 06	2437	16.99
CH 09	2452	14.16



MIMO<Ant. 1 + 2>

802.11b mode		
Power vs. Channel		
Channel	Frequency (MHz)	Data Rate (bps)
		1M
CH 01	2412	20.64
CH 02	2417	20.83
CH 06	2437	20.83
CH 10	2457	20.60
CH 11	2462	20.31

802.11g mode		
Power vs. Channel		
Channel	Frequency (MHz)	Data Rate (bps)
		6M
CH 01	2412	16.50
CH 02	2417	20.17
CH 06	2437	20.17
CH 10	2457	18.51
CH 11	2462	18.08

802.11n HT20 mode		
Power vs. Channel		
Channel	Frequency (MHz)	MCS Index
		MCS0
CH 01	2412	14.88
CH 02	2417	20.09
CH 06	2437	20.09
CH 10	2457	17.70
CH 11	2462	16.73



802.11n HT40 mode		
Power vs. Channel		
Channel	Frequency (MHz)	MCS Index
		MCS0
CH 03	2422	11.81
CH 06	2437	17.81
CH 09	2452	12.86



<TXBF Mode>

MIMO<Ant 1 + 2>

802.11n HT20 mode		
Power vs. Channel		
Channel	Frequency (MHz)	MCS Index
		MCS0
CH 01	2412	16.56
CH 02	2417	21.46
CH 06	2437	21.36
CH 10	2457	20.91
CH 11	2462	17.51

802.11n HT40 mode		
Power vs. Channel		
Channel	Frequency (MHz)	MCS Index
		MCS0
CH 03	2422	15.76
CH 06	2437	19.56
CH 09	2452	19.52

Remark: For radiated test cases, the test was performed with SKU 7, Keypad (46), MC32 1X Battery, USB Link with Adapter, PWR-WUA5V12W0US(LV6).

2.3 Connection Diagram of Test System

<WLAN Tx Mode>

<CDD Mode>

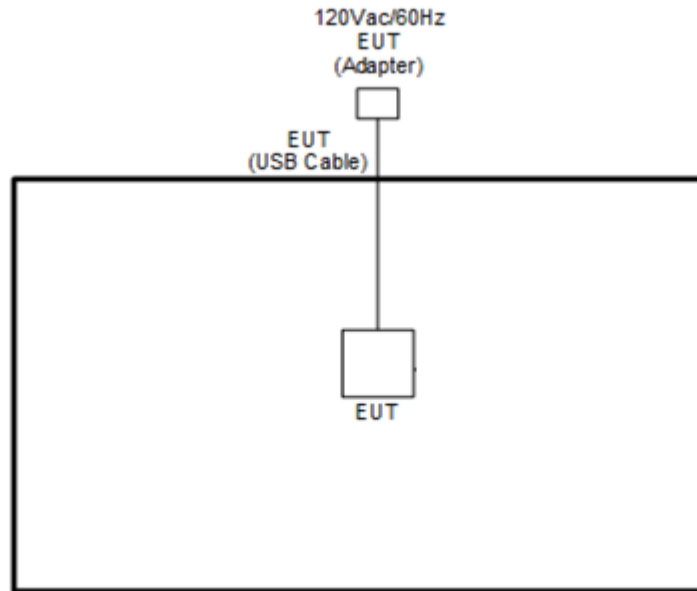

<TXBF Mode>

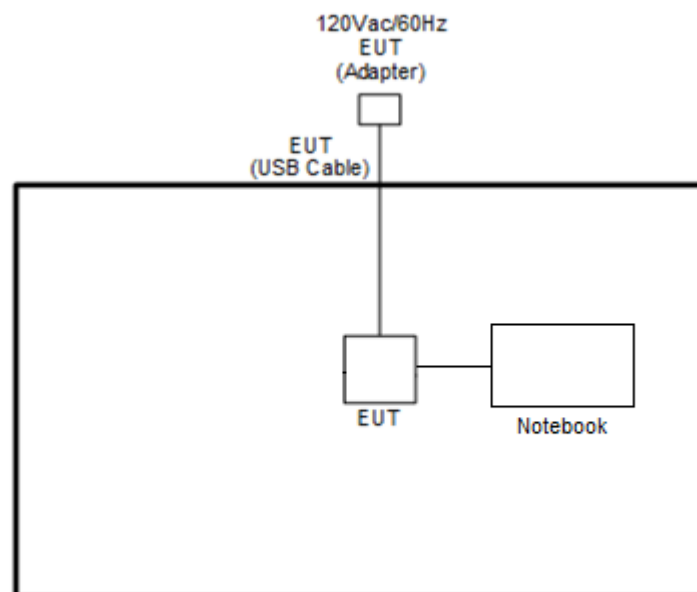



2.4 Support Unit used in test configuration and system

Item	Equipment	Trade Name	Model Name	FCC ID	Data Cable	Power Cord
1.	Notebook-40(Tx)	Lenovo	E335	N/A	N/A	AC I/P: Unshielded, 1.2 m DC O/P: Shielded, 1.8 m
2.	Notebook-53(Rx)	ASUS	K42J	N/A	N/A	AC I/P: Unshielded, 1.2 m DC O/P: Shielded, 1.8 m

2.5 EUT Operation Test Setup

The RF test items, programmed RF utility, “Wi-Fi RF Test” installed in the notebook make the EUT provide functions like channel selection and power level for continuous transmitting and receiving signals.

For WLAN MIMO TXBF modes, the EUT was tested under normal operation and link to another device with power, modulation modes and data rates controlled by engineer mode command lines. The CMD software tool was used to make EUT continuous transmitting signals.



3 Test Result

3.1 Output Power Measurement

3.1.1 Limit of Output Power

For systems using digital modulation in the 2400-2483.5MHz, the limit for output power is 30dBm. If transmitting antenna with directional gain greater than 6dBi is used, the output power from the intentional radiator shall be reduced below the above stated value by the amount in dB that the directional gain of the antenna exceeds 6 dBi. In case of point-to-point operation, the limit has to be reduced by 1dB for every 3dB that the directional gain of the antenna exceeds 6dBi.

3.1.2 Measuring Instruments

The measuring equipment is listed in the section 4 of this test report.

3.1.3 Test Procedures

CDD Modes

1. The testing follows the Measurement Procedure of FCC KDB No. 558074 DTS D01 Meas. Guidance v04 section 9.2.3.1 Method AVGPM.
2. The RF output of EUT was connected to the power meter by RF cable and attenuator. The path loss was compensated to the results for each measurement.
3. Set to the maximum power setting and enable the EUT transmit continuously.
4. Measure the conducted output power and record the results in the test report.
5. For MIMO mode, calculation method follows FCC KDB 662911 D01 Multiple Transmitter Output v02r01.

TXBF Modes

1. The testing follows the Measurement Procedure of FCC KDB No. 558074 DTS D01 Meas. Guidance v04 section 9.2.3.2 Method AVGPM-G.
2. The RF output of EUT was connected to the power meter by RF cable and attenuator. The path loss was compensated to the results for each measurement.
3. Set to the maximum power setting and enable the EUT transmit continuously.
4. Measure the conducted output power and record the results in the test report.
5. For MIMO mode, calculation method follows FCC KDB 662911 D01 Multiple Transmitter Output v02r01.

3.1.4 Test Setup

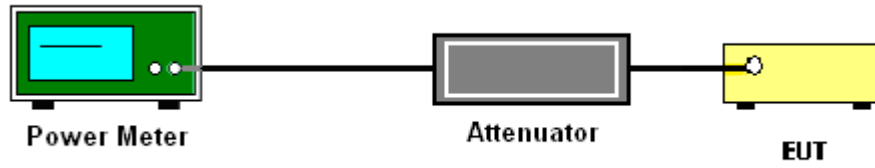



3.1.5 Test Result of Peak Output Power (Reporting Only)

<CDD Modes>

2.4GHz Band											
Mod.	Data Rate	NTX	CH.	Freq. (MHz)	Peak Conducted Power (dBm)			DG (dBi)		EIRP Power (dBm)	
					Ant 1	Ant 2	SUM	Ant 1	Ant 2	Ant 1	Ant 2
11b	1Mbps	1	1	2412	21.28	21.20		3.86	3.63	25.14	24.83
11b	1Mbps	1	2	2417	21.29	21.25		3.86	3.63	25.15	24.88
11b	1Mbps	1	6	2437	21.31	21.30		3.86	3.63	25.17	24.93
11b	1Mbps	1	10	2457	21.21	21.20		3.86	3.63	25.07	24.83
11b	1Mbps	1	11	2462	21.17	21.25		3.86	3.63	25.03	24.88
11g	6Mbps	1	1	2412	20.25	19.65		3.86	3.63	24.11	23.28
11g	6Mbps	1	2	2417	23.01	23.20		3.86	3.63	26.87	26.83
11g	6Mbps	1	6	2437	23.20	23.16		3.86	3.63	27.06	26.79
11g	6Mbps	1	10	2457	23.13	23.10		3.86	3.63	26.99	26.73
11g	6Mbps	1	11	2462	20.00	19.94		3.86	3.63	23.86	23.57
HT20	MCS0	1	1	2412	18.11	17.50		3.86	3.63	21.97	21.13
HT20	MCS0	1	2	2417	23.37	23.22		3.86	3.63	27.23	26.85
HT20	MCS0	1	6	2437	23.40	23.38		3.86	3.63	27.26	27.01
HT20	MCS0	1	10	2457	23.39	23.00		3.86	3.63	27.25	26.63
HT20	MCS0	1	11	2462	19.30	19.60		3.86	3.63	23.16	23.23
HT40	MCS0	1	3	2422	19.79	19.71		3.86	3.63	23.65	23.34
HT40	MCS0	1	6	2437	22.95	23.34		3.86	3.63	26.81	26.97
HT40	MCS0	1	9	2452	21.50	21.38		3.86	3.63	25.36	25.01
11b	1Mbps	2	1	2412	20.53	20.90	23.73	3.86		27.59	
11b	1Mbps	2	2	2417	20.91	20.72	23.93	3.86		27.79	
11b	1Mbps	2	6	2437	20.56	21.25	23.93	3.86		27.79	
11b	1Mbps	2	10	2457	20.50	20.56	23.54	3.86		27.40	
11b	1Mbps	2	11	2462	19.80	20.25	23.04	3.86		26.90	



2.4GHz Band											
Mod.	Data Rate	NTX	CH.	Freq. (MHz)	Peak Conducted Power (dBm)			DG (dBi)		EIRP Power (dBm)	
					Ant 1	Ant 2	SUM	Ant 1	Ant 2	Ant 1	Ant 2
11g	6Mbps	2	1	2412	20.21	20.15	23.19	3.86		27.05	
11g	6Mbps	2	2	2417	23.10	23.03	26.18	3.86		30.04	
11g	6Mbps	2	6	2437	23.03	23.30	26.18	3.86		30.04	
11g	6Mbps	2	10	2457	21.60	21.80	24.71	3.86		28.57	
11g	6Mbps	2	11	2462	21.40	21.60	24.51	3.86		28.37	
HT20	MCS0	2	1	2412	18.85	19.03	21.95	3.86		25.81	
HT20	MCS0	2	2	2417	23.31	23.11	26.26	3.86		30.12	
HT20	MCS0	2	6	2437	23.37	23.12	26.26	3.86		30.12	
HT20	MCS0	2	10	2457	21.31	21.40	24.37	3.86		28.23	
HT20	MCS0	2	11	2462	20.60	20.49	23.56	3.86		27.42	
HT40	MCS0	2	3	2422	16.00	15.68	18.85	3.86		22.71	
HT40	MCS0	2	6	2437	21.60	21.83	24.73	3.86		28.59	
HT40	MCS0	2	9	2452	16.60	17.10	19.87	3.86		23.73	



3.1.6 Test Result of Average output Power

<CDD Mode>

2.4GHz Band																		
Mod.	Data Rate	NTX	CH.	Freq. (MHz)	Duty Factor (dB)		Average Conducted Power (dBm)			Conducted Power Limit (dBm)		DG (dBi)		EIRP Power (dBm)		EIRP Power Limit (dBm)		Pass /Fail
					Ant 1	Ant 2	Ant 1	Ant 2	SUM	Ant 1	Ant 2	Ant 1	Ant 2	Ant 1	Ant 2	Ant 1	Ant 2	
11b	1Mbps	1	1	2412	0.00	0.00	18.10	18.13		30.00	30.00	3.86	3.63	21.96	21.76	36.00	36.00	Pass
11b	1Mbps	1	2	2417	0.00	0.00	18.12	18.11		30.00	30.00	3.86	3.63	21.98	21.74	36.00	36.00	Pass
11b	1Mbps	1	6	2437	0.00	0.00	18.16	18.15		30.00	30.00	3.86	3.63	22.02	21.78	36.00	36.00	Pass
11b	1Mbps	1	10	2457	0.00	0.00	18.13	18.12		30.00	30.00	3.86	3.63	21.99	21.75	36.00	36.00	Pass
11b	1Mbps	1	11	2462	0.00	0.00	18.10	18.18		30.00	30.00	3.86	3.63	21.96	21.81	36.00	36.00	Pass
11g	6Mbps	1	1	2412	0.21	0.17	13.44	13.03		30.00	30.00	3.86	3.63	17.30	16.66	36.00	36.00	Pass
11g	6Mbps	1	2	2417	0.21	0.17	17.03	17.23		30.00	30.00	3.86	3.63	20.89	20.86	36.00	36.00	Pass
11g	6Mbps	1	6	2437	0.21	0.17	17.13	17.07		30.00	30.00	3.86	3.63	20.99	20.70	36.00	36.00	Pass
11g	6Mbps	1	10	2457	0.21	0.17	17.11	17.13		30.00	30.00	3.86	3.63	20.97	20.76	36.00	36.00	Pass
11g	6Mbps	1	11	2462	0.21	0.17	13.21	13.20		30.00	30.00	3.86	3.63	17.07	16.83	36.00	36.00	Pass
HT20	MCS0	1	1	2412	0.18	0.22	11.15	11.04		30.00	30.00	3.86	3.63	15.01	14.67	36.00	36.00	Pass
HT20	MCS0	1	2	2417	0.18	0.22	17.00	17.19		30.00	30.00	3.86	3.63	20.86	20.82	36.00	36.00	Pass
HT20	MCS0	1	6	2437	0.18	0.22	17.03	17.02		30.00	30.00	3.86	3.63	20.89	20.65	36.00	36.00	Pass
HT20	MCS0	1	10	2457	0.18	0.22	17.00	17.02		30.00	30.00	3.86	3.63	20.86	20.65	36.00	36.00	Pass
HT20	MCS0	1	11	2462	0.18	0.22	12.13	12.49		30.00	30.00	3.86	3.63	15.99	16.12	36.00	36.00	Pass
HT40	MCS0	1	3	2422	0.23	0.23	12.63	12.53		30.00	30.00	3.86	3.63	16.49	16.16	36.00	36.00	Pass
HT40	MCS0	1	6	2437	0.23	0.23	16.51	16.99		30.00	30.00	3.86	3.63	20.37	20.62	36.00	36.00	Pass
HT40	MCS0	1	9	2452	0.23	0.23	14.38	14.16		30.00	30.00	3.86	3.63	18.24	17.79	36.00	36.00	Pass
11b	1Mbps	2	1	2412	0.00	0.00	17.40	17.85	20.64	30.00		3.86		24.50		36.00		Pass
11b	1Mbps	2	2	2417	0.00	0.00	17.82	17.83	20.83	30.00		3.86		24.69		36.00		Pass
11b	1Mbps	2	6	2437	0.00	0.00	17.40	18.20	20.83	30.00		3.86		24.69		36.00		Pass
11b	1Mbps	2	10	2457	0.00	0.00	17.60	17.58	20.60	30.00		3.86		24.46		36.00		Pass
11b	1Mbps	2	11	2462	0.00	0.00	17.10	17.50	20.31	30.00		3.86		24.17		36.00		Pass



2.4GHz Band																		
Mod.	Data Rate	NTX	CH.	Freq. (MHz)	Duty Factor (dB)		Average Conducted Power (dBm)			Conducted Power Limit (dBm)		DG (dBi)		EIRP Power (dBm)		EIRP Power Limit (dBm)		Pass /Fail
					Ant 1	Ant 2	Ant 1	Ant 2	SUM	Ant 1	Ant 2	Ant 1	Ant 2	Ant 1	Ant 2	Ant 1	Ant 2	
11g	6Mbps	2	1	2412	0.18	0.21	13.44	13.55	16.50	30.00	3.86	20.36	36.00	Pass				
11g	6Mbps	2	2	2417	0.18	0.21	17.00	17.06	20.17	30.00	3.86	24.03	36.00	Pass				
11g	6Mbps	2	6	2437	0.18	0.21	17.05	17.28	20.17	30.00	3.86	24.03	36.00	Pass				
11g	6Mbps	2	10	2457	0.18	0.21	15.40	15.60	18.51	30.00	3.86	22.37	36.00	Pass				
11g	6Mbps	2	11	2462	0.18	0.21	14.96	15.18	18.08	30.00	3.86	21.94	36.00	Pass				
HT20	MCS0	2	1	2412	0.22	0.18	11.87	11.86	14.88	30.00	3.86	18.74	36.00	Pass				
HT20	MCS0	2	2	2417	0.22	0.18	16.82	16.83	20.09	30.00	3.86	23.95	36.00	Pass				
HT20	MCS0	2	6	2437	0.22	0.18	17.07	17.08	20.09	30.00	3.86	23.95	36.00	Pass				
HT20	MCS0	2	10	2457	0.22	0.18	14.57	14.80	17.70	30.00	3.86	21.56	36.00	Pass				
HT20	MCS0	2	11	2462	0.22	0.18	13.59	13.84	16.73	30.00	3.86	20.59	36.00	Pass				
HT40	MCS0	2	3	2422	0.20	0.20	8.90	8.70	11.81	30.00	3.86	15.67	36.00	Pass				
HT40	MCS0	2	6	2437	0.20	0.20	14.70	14.90	17.81	30.00	3.86	21.67	36.00	Pass				
HT40	MCS0	2	9	2452	0.20	0.20	9.91	9.80	12.86	30.00	3.86	16.72	36.00	Pass				



<TXBF Mode>

2.4GHz Band																		
Mod.	Data Rate	NTX	CH.	Freq. (MHz)	Duty Factor (dB)		Average Conducted Power (dBm)			Conducted Power Limit (dBm)		DG (dBi)		EIRP Power (dBm)		EIRP Power Limit (dBm)		Pass /Fail
					Ant 1	Ant 2	Ant 1	Ant 2	SUM	Ant 1	Ant 2	Ant 1	Ant 2	Ant 1	Ant 2	Ant 1	Ant 2	
HT20	MCS0	2	1	2412	0.00	0.00	13.40	13.70	16.56	30.00	6.76	23.32	36.00	Pass				
HT20	MCS0	2	2	2417	0.00	0.00	18.60	18.30	21.46	30.00	6.76	28.22	36.00	Pass				
HT20	MCS0	2	6	2437	0.00	0.00	18.40	18.30	21.36	30.00	6.76	28.12	36.00	Pass				
HT20	MCS0	2	10	2457	0.00	0.00	17.80	18.00	20.91	30.00	6.76	27.67	36.00	Pass				
HT20	MCS0	2	11	2462	0.00	0.00	14.40	14.60	17.51	30.00	6.76	24.27	36.00	Pass				
HT40	MCS0	2	3	2422	0.00	0.00	12.60	12.90	15.76	30.00	6.76	22.52	36.00	Pass				
HT40	MCS0	2	6	2437	0.00	0.00	16.50	16.60	19.56	30.00	6.76	26.32	36.00	Pass				
HT40	MCS0	2	9	2452	0.00	0.00	16.20	16.80	19.52	30.00	6.76	26.28	36.00	Pass				



3.2 Radiated Band Edges and Spurious Emission Measurement

3.2.1 Limit of Radiated band edge and Spurious Emission Measurement

In any 100 kHz bandwidth outside the intentional radiator frequency band, all harmonics/spurious must be at least 20 dB below the highest emission level within the authorized band. If the output power of this device was measured by spectrum analyzer, the attenuation under this paragraph shall be 30 dB instead of 20 dB. In addition, radiated emissions which fall in the restricted bands must also comply with the limits as below.

Frequency (MHz)	Field Strength (microvolts/meter)	Measurement Distance (meters)
0.009 – 0.490	2400/F(kHz)	300
0.490 – 1.705	24000/F(kHz)	30
1.705 – 30.0	30	30
30 – 88	100	3
88 – 216	150	3
216 - 960	200	3
Above 960	500	3

3.2.2 Measuring Instruments

The measuring equipment is listed in the section 4 of this test report.



3.2.3 Test Procedures

1. The testing follows FCC KDB Publication No. 558074 D01 DTS Meas. Guidance v04.
2. The EUT was arranged to its worst case and then tune the antenna tower (from 1 m to 4 m) and turntable (from 0 degree to 360 degrees) to find the maximum reading. A pre-amp and a high pass filter are used for the test in order to get better signal level.
3. The EUT was placed on a turntable with 0.8 meter for frequency below 1GHz and 1.5 meter for frequency above 1GHz respectively above ground.
4. The EUT was set 3 meters from the interference receiving antenna, which was mounted on the top of a variable height antenna tower.
5. Corrected Reading: Antenna Factor + Cable Loss + Read Level - Preamp Factor = Level
6. For measurement below 1GHz, If the emission level of the EUT measured by the peak detector is 3 dB lower than the applicable limit, the peak emission level will be reported. Otherwise, the emission measurement will be repeated using the quasi-peak detector and reported.
7. Use the following spectrum analyzer settings:
 - (1) Span shall wide enough to fully capture the emission being measured;
 - (2) Set RBW=100 kHz for $f < 1$ GHz; VBW \geq RBW; Sweep = auto; Detector function = peak; Trace = max hold;
 - (3) Set RBW = 1 MHz, VBW= 3MHz for $f \geq 1$ GHz for peak measurement.
For average measurement:
 - VBW = 10 Hz, when duty cycle is no less than 98 percent.
 - VBW $\geq 1/T$, when duty cycle is less than 98 percent where T is the minimum transmission duration over which the transmitter is on and is transmitting at its maximum power control level for the tested mode of operation.

3.2.4 Test Setup

For radiated emissions below 30MHz

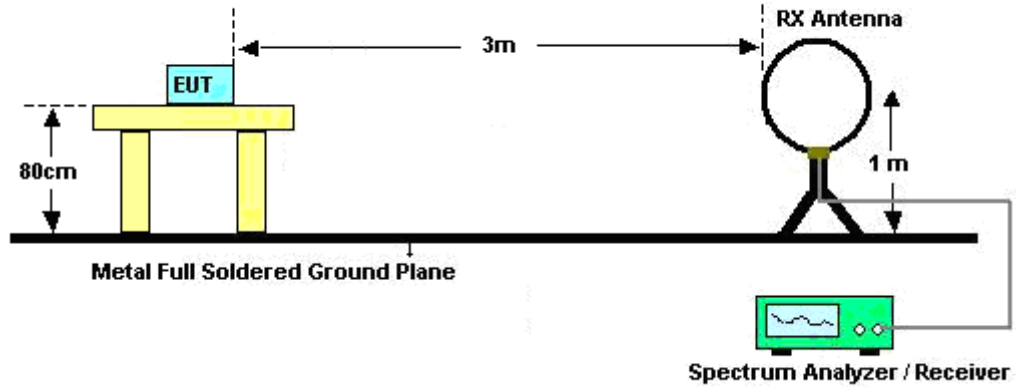

For radiated emissions from 30MHz to 1GHz

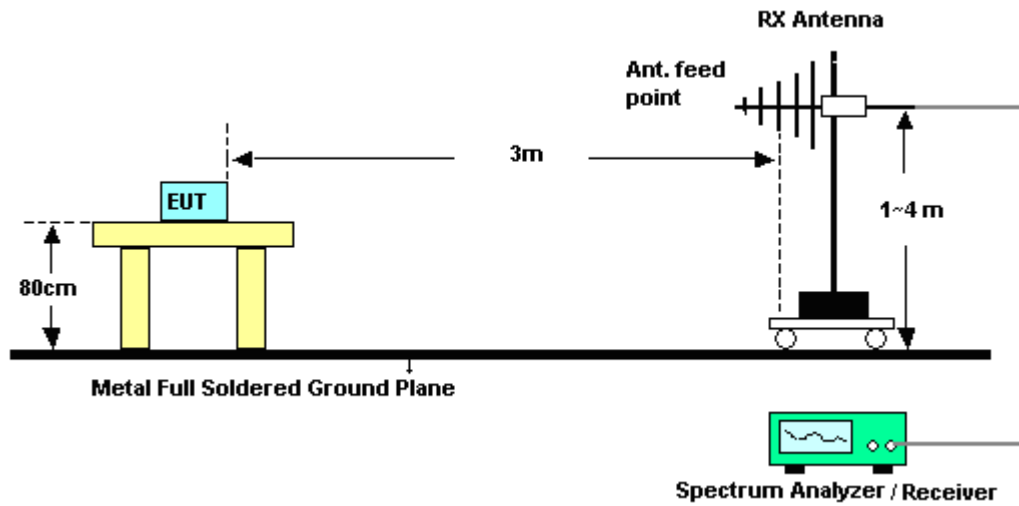

For radiated emissions above 1GHz

<CDD Modes>

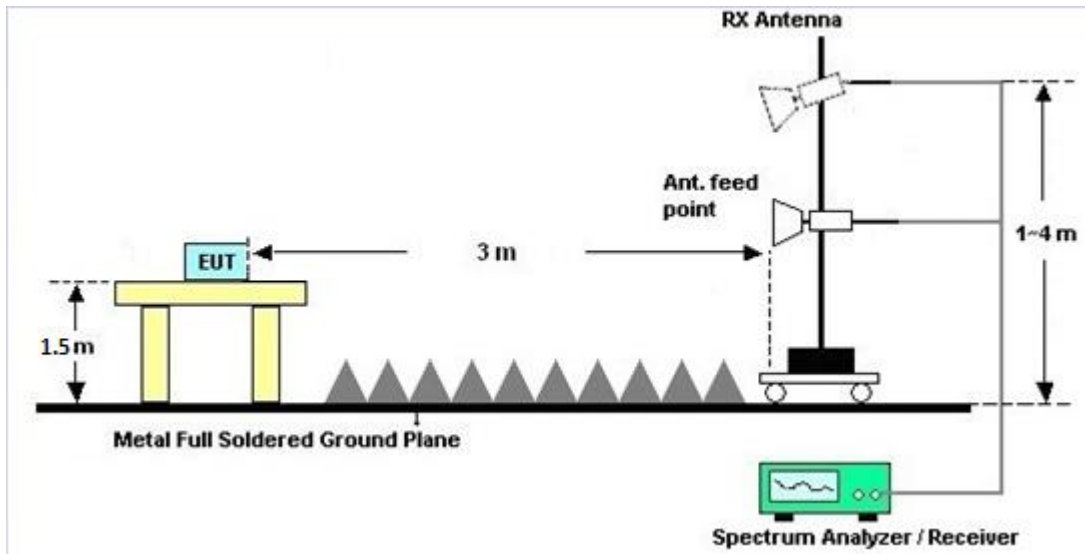

<TXBF Modes>

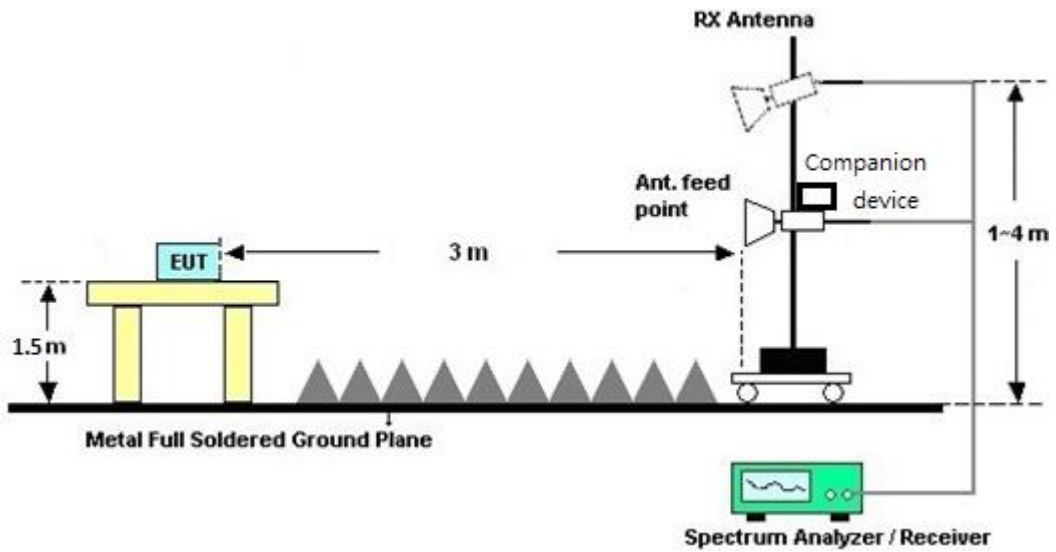



3.2.5 Test Results of Radiated Spurious Emissions (9kHz ~ 30MHz)

The low frequency, which started from 9 kHz to 30MHz, was pre-scanned and the result which was 20dB lower than the limit line was not reported.

3.2.6 Test Result of Radiated Spurious at Band Edges

Please refer to Appendix A and B.

3.2.7 Duty Cycle

Please refer to Appendix C.

3.2.8 Test Result of Radiated Spurious Emission (30MHz ~ 10th Harmonic)

Please refer to Appendix A and B.



3.3 Antenna Requirements

3.3.1 Standard Applicable

If directional gain of transmitting Antennas is greater than 6dBi, the power shall be reduced by the same level in dB comparing to gain minus 6dBi. The use of a permanently attached Antenna or of an Antenna that uses a unique coupling to the intentional radiator shall be considered sufficient to comply with the rule.

3.3.2 Antenna Anti-Replacement Construction

An embedded-in antenna design is used.

3.3.3 Antenna Gain

CDD modes

FCC KDB 662911 D01 Multiple Transmitter Output v02r01

For CDD transmissions, directional gain is calculated as

Directional gain = $G_{ANT} + \text{Array Gain}$, where Array Gain is as follows.

For power spectral density (PSD) measurements on all devices,

Array Gain = $10 \log(N_{ANT}/N_{SS}=1)$ dB.

For power measurements on IEEE 802.11 devices,

Array Gain = 0 dB (i.e., no array gain) for $N_{ANT} \leq 4$.

Directional gain may be calculated by using the formulas applicable to equal gain antennas with G_{ANT} set equal to the gain of the antenna having the highest gain;

The EUT supports CDD mode.

For power, the directional gain G_{ANT} is set equal to the antenna having the highest gain, i.e., F)2)f)i).

For PSD, the directional gain calculation is following F)2)f)ii) of KDB 662911 D01 v02r01.

The power and PSD limit should be modified if the directional gain of EUT is over 6 dBi,

The directional gain "DG" is calculated as following table.

			DG for Power (dBi)	DG for PSD (dBi)	Power Limit Reduction (dB)	PSD Limit Reduction (dB)
	Chain 1 (dBi)	Chain 2 (dBi)				
2.4 GHz	3.86	3.63	3.86	6.76	0.00	0.76

$Power\ Limit\ Reduction = DG(Power) - 6dBi, (min = 0)$

$PSD\ Limit\ Reduction = DG(PSD) - 6dBi, (min = 0)$



TXBF modes

FCC KDB 662911 D01 Multiple Transmitter Output v02r01

For CDD transmissions, directional gain is calculated as

$$DirectionalGain = 10 \cdot \log \left[\frac{\sum_{j=1}^{N_{SS}} \left\{ \sum_{k=1}^{N_{ANT}} g_{j,k} \right\}^2}{N_{ANT}} \right]$$

where

Each antenna is driven by no more than one spatial stream;

N_{SS} = the number of independent spatial streams of data;

N_{ANT} = the total number of antennas

$g_{j,k} = 10^{G_k / 20}$ if the k th antenna is being fed by spatial stream j , or zero if it is not;
 G_k is the gain in dBi of the k th antenna.

The EUT supports beamforming for 802.11ac modes.

The directional gain calculation is following F2)e)ii) of KDB 662911 D01 v02r01.

The power and PSD limit should be modified if the directional gain of EUT is over 6 dBi,

The directional gain “DG” is calculated as following table.

			DG	DG	Power	PSD
			for	for	Limit	Limit
	Ant. 1	Ant. 2	Power	PSD	Reduction	Reduction
	(dBi)	(dBi)	(dBi)	(dBi)	(dB)	(dB)
2.4 GHz	3.86	3.63	6.76	6.76	0.76	0.76

Power Limit Reduction = DG(Power) – 6dBi, (min = 0)

PSD Limit Reduction = DG(PSD) – 6dBi, (min = 0)



4 List of Measuring Equipment

Instrument	Manufacturer	Model No.	Serial No.	Characteristics	Calibration Date	Test Date	Due Date	Remark
Power Meter	Anritsu	ML2495A	0932001	N/A	Sep. 26, 2017	Oct. 04, 2017	Sep. 25, 2018	Conducted-CDD (TH05-HY)
Power Sensor	Anritsu	MA2411B	0846202	300MHz~40GHz	Sep. 26, 2017	Oct. 04, 2017	Sep. 25, 2018	Conducted-CDD (TH05-HY)
Spectrum Analyzer	Rohde & Schwarz	FSP30	101067	9kHz ~ 30GHz	Nov. 17, 2016	Oct. 04, 2017	Nov. 16, 2017	Conducted-CDD (TH05-HY)
Power Sensor	DARE	RPR3006W	16100054S NO11	10MHz~6GHz	Dec. 22, 2016	Oct. 16, 2017	Dec. 21, 2017	Conducted-TXBF (TH05-HY)
Signal Analyzer	Rohde & Schwarz	FSV40	101408	10Hz~40GHz	Jul. 20, 2017	Oct. 16, 2017	Jul. 19, 2018	Conducted-TXBF (TH05-HY)
Spectrum Analyzer	Rohde & Schwarz	FSP40	100057	9kHz-40GHz	Nov. 25, 2016	Oct. 16, 2017	Nov. 24, 2017	Conducted-TXBF (TH05-HY)
Programmable Power Supply	GW Instek	PSS-2005	EL890089	1V~20V 0.5A~5A	Jan. 12, 2017	Oct. 16, 2017	Jan. 11, 2018	Conducted-TXBF (TH05-HY)
Amplifier	SONOMA	310N	187312	9kHz~1GHz	Nov. 10, 2016	Oct. 13, 2017 ~ Oct. 17, 2017	Nov. 09, 2017	Radiation (03CH12-HY)
Bilog Antenna	TESEQ	CBL 6111D&00800 N1D01N-06	35413&02	30MHz~1GHz	Jan. 07, 2017	Oct. 13, 2017 ~ Oct. 17, 2017	Jan. 06, 2018	Radiation (03CH12-HY)
EMI Test Receiver	Rohde & Schwarz	ESU26	100390	20Hz~26.5GHz	Dec. 23, 2016	Oct. 13, 2017 ~ Oct. 17, 2017	Dec. 22, 2017	Radiation (03CH12-HY)
Horn Antenna	SCHWARZBECK	BBHA 9120D	9120D-132 8	1GHz ~ 18GHz	Oct. 25, 2016	Oct. 13, 2017 ~ Oct. 17, 2017	Oct. 24, 2017	Radiation (03CH12-HY)
Preamplifier	MITEQ	AMF-7D-0010 1800-30-10P	1815698	1GHz~18GHz	Dec. 01, 2016	Oct. 13, 2017 ~ Oct. 17, 2017	Nov. 30, 2017	Radiation (03CH12-HY)
Preamplifier	Keysight	83017A	MY532701 48	1GHz~26.5GHz	Jan. 12, 2017	Oct. 13, 2017 ~ Oct. 17, 2017	Jan. 11, 2018	Radiation (03CH12-HY)
Filter	Wainwright	WHKX12-270 0-3000-18000 -60ST	SN2	3 GHz Highpass	Mar. 24, 2017	Oct. 13, 2017 ~ Oct. 17, 2017	Mar. 23, 2018	Radiation (03CH12-HY)
Filter	Wainwright	WLKS1200-1 2SS	SN2	1.2G Low Pass	Mar. 24, 2017	Oct. 13, 2017 ~ Oct. 17, 2017	Mar. 23, 2018	Radiation (03CH12-HY)
Antenna Mast	EMEC	AM-BS-4500- B	N/A	1m~4m	N/A	Oct. 13, 2017 ~ Oct. 17, 2017	N/A	Radiation (03CH12-HY)
Turn Table	EMEC	TT2000	N/A	0~360 Degree	N/A	Oct. 13, 2017 ~ Oct. 17, 2017	N/A	Radiation (03CH12-HY)
Attenuator	Fairview Microwave	SA18S5W-10	n/a	10db	Mar. 24, 2017	Oct. 13, 2017 ~ Oct. 17, 2017	Mar. 23, 2018	Radiation (03CH12-HY)
SHF-EHF Horn Antenna	SCHWARZBECK	BBHA 9170	BBHA9170 576	18GHz ~ 40GHz	Apr. 27, 2017	Oct. 13, 2017 ~ Oct. 17, 2017	Apr. 26, 2018	Radiation (03CH12-HY)
Preamplifier	MITEQ	TTA1840-35- HG	1887435	18GHz~40GHz	Jul. 18, 2017	Oct. 13, 2017 ~ Oct. 17, 2017	Jul. 17, 2018	Radiation (03CH12-HY)



5 Uncertainty of Evaluation

Uncertainty of Radiated Emission Measurement (30 MHz ~ 1000 MHz)

Measuring Uncertainty for a Level of Confidence of 95% ($U = 2Uc(y)$)	5.10
---	------

Uncertainty of Radiated Emission Measurement (1000 MHz ~ 18000 MHz)

Measuring Uncertainty for a Level of Confidence of 95% ($U = 2Uc(y)$)	5.20
---	------

Uncertainty of Radiated Emission Measurement (18000 MHz ~ 40000 MHz)

Measuring Uncertainty for a Level of Confidence of 95% ($U = 2Uc(y)$)	4.70
---	------



Appendix A. Radiated Spurious Emission

Test Engineer :	Ray Chen, J.C. Liang and Nick Yu	Temperature :	23~25°C
		Relative Humidity :	59~63%

2.4GHz 2400~2483.5MHz

WIFI 802.11b (Band Edge @ 3m)

WIFI	Note	Frequency	Level	Over	Limit	Read	Antenna	Cable	Preamp	Ant	Table	Peak	Pol.	
Ant.				Limit	Line	Level	Factor	Loss	Factor	Pos	Pos	Avg.		
1		(MHz)	(dBμV/m)	(dB)	(dBμV/m)	(dBμV)	(dB/m)	(dB)	(dB)	(cm)	(deg)	(P/A)	(H/V)	
802.11b CH 01 2412MHz		2387.91	52.7	-21.3	74	42.76	27.37	4.03	31.49	396	26	P	H	
		2390	43.54	-10.46	54	33.6	27.37	4.03	31.49	396	26	A	H	
	*	2412	101.8	-	-	91.79	27.42	4.05	31.49	396	26	P	H	
	*	2412	97.46	-	-	87.45	27.42	4.05	31.49	396	26	A	H	
													H	
														H
			2390	57.64	-16.36	74	47.7	27.37	4.03	31.49	198	334	P	V
			2390	50.64	-3.36	54	40.7	27.37	4.03	31.49	198	334	A	V
	*		2412	110.91	-	-	100.9	27.42	4.05	31.49	198	334	P	V
	*		2412	106.48	-	-	96.47	27.42	4.05	31.49	198	334	A	V
														V
														V
Remark	1. No other spurious found. 2. All results are PASS against Peak and Average limit line.													



2.4GHz 2400~2483.5MHz

WIFI 802.11b (Harmonic @ 3m)

WIFI Ant. 1	Note	Frequency (MHz)	Level (dBμV/m)	Over Limit (dB)	Limit Line (dBμV/m)	Read Level (dBμV)	Antenna Factor (dB/m)	Cable Loss (dB)	Preamp Factor (dB)	Ant Pos (cm)	Table Pos (deg)	Peak Avg. (P/A)	Pol. (H/V)	
802.11b CH 01 2412MHz		4824	39.88	-34.12	74	59.7	31.79	6.17	58.31	100	0	P	H	
													H	
													H	
													H	
			4824	46.64	-27.36	74	66.46	31.79	6.17	58.31	100	0	P	V
														V
														V
Remark	1. No other spurious found. 2. All results are PASS against Peak and Average limit line.													



**2.4GHz 2400~2483.5MHz
WIFI 802.11g (Band Edge @ 3m)**

WIFI Ant. 1	Note	Frequency (MHz)	Level (dBμV/m)	Over Limit (dB)	Limit Line (dBμV/m)	Read Level (dBμV)	Antenna Factor (dB/m)	Cable Loss (dB)	Preamp Factor (dB)	Ant Pos (cm)	Table Pos (deg)	Peak Avg. (P/A)	Pol. (H/V)	
802.11g CH 01 2412MHz		2389.275	54.72	-19.28	74	44.78	27.37	4.03	31.49	395	42	P	H	
		2390	44.75	-9.25	54	34.81	27.37	4.03	31.49	395	42	A	H	
	*	2412	99.22	-	-	89.21	27.42	4.05	31.49	395	42	P	H	
	*	2412	89.54	-	-	79.53	27.42	4.05	31.49	395	42	A	H	
													H	
													H	
			2390	61.97	-12.03	74	52.03	27.37	4.03	31.49	198	345	P	V
			2390	51.43	-2.57	54	41.49	27.37	4.03	31.49	198	345	A	V
	*		2412	108.89	-	-	98.88	27.42	4.05	31.49	198	345	P	V
	*		2412	98.89	-	-	88.88	27.42	4.05	31.49	198	345	A	V
													V	
													V	
Remark	1. No other spurious found. 2. All results are PASS against Peak and Average limit line.													



2.4GHz 2400~2483.5MHz

WIFI 802.11g (Harmonic @ 3m)

WIFI Ant. 1	Note	Frequency (MHz)	Level (dBμV/m)	Over Limit (dB)	Limit Line (dBμV/m)	Read Level (dBμV)	Antenna Factor (dB/m)	Cable Loss (dB)	Preamp Factor (dB)	Ant Pos (cm)	Table Pos (deg)	Peak Avg. (P/A)	Pol. (H/V)	
802.11g CH 01 2412MHz		4824	38.57	-35.43	74	58.39	31.79	6.17	58.31	100	0	P	H	
													H	
													H	
													H	
			4824	40.87	-33.13	74	60.69	31.79	6.17	58.31	100	0	P	V
														V
														V
														V
Remark	1. No other spurious found. 2. All results are PASS against Peak and Average limit line.													



**2.4GHz 2400~2483.5MHz
WIFI 802.11n HT20 (Band Edge @ 3m)**

WIFI Ant. 1	Note	Frequency (MHz)	Level (dBμV/m)	Over Limit (dB)	Limit Line (dBμV/m)	Read Level (dBμV)	Antenna Factor (dB/m)	Cable Loss (dB)	Preamp Factor (dB)	Ant Pos (cm)	Table Pos (deg)	Peak Avg. (P/A)	Pol. (H/V)	
802.11n HT20 CH 01 2412MHz		2390	54.59	-19.41	74	44.65	27.37	4.03	31.49	398	39	P	H	
		2390	43.14	-10.86	54	33.2	27.37	4.03	31.49	398	39	A	H	
	*	2412	96.67	-	-	86.66	27.42	4.05	31.49	398	39	P	H	
	*	2412	87.22	-	-	77.21	27.42	4.05	31.49	398	39	A	H	
													H	
													H	
			2390	61.86	-12.14	74	51.92	27.37	4.03	31.49	231	333	P	V
			2390	49.07	-4.93	54	39.13	27.37	4.03	31.49	231	333	A	V
		*	2412	106.18	-	-	96.17	27.42	4.05	31.49	231	333	P	V
		*	2412	96.55	-	-	86.54	27.42	4.05	31.49	231	333	A	V
													V	
													V	
Remark	1. No other spurious found. 2. All results are PASS against Peak and Average limit line.													



**2.4GHz 2400~2483.5MHz
WIFI 802.11n HT20 (Harmonic @ 3m)**

WIFI Ant. 1	Note	Frequency (MHz)	Level (dBμV/m)	Over Limit (dB)	Limit Line (dBμV/m)	Read Level (dBμV)	Antenna Factor (dB/m)	Cable Loss (dB)	Preamp Factor (dB)	Ant Pos (cm)	Table Pos (deg)	Peak Avg. (P/A)	Pol. (H/V)
802.11n HT20 CH 01		4824	39.24	-34.76	74	59.06	31.79	6.17	58.31	100	0	P	H
													H
													H
													H
2412MHz		4824	38.55	-35.45	74	58.37	31.79	6.17	58.31	100	0	P	V
													V
													V
Remark	1. No other spurious found. 2. All results are PASS against Peak and Average limit line.												



2.4GHz 2400~2483.5MHz
WIFI 802.11n HT40 (Band Edge @ 3m)

Table with 14 columns: WIFI Ant. 1, Note, Frequency (MHz), Level (dBµV/m), Over Limit (dB), Limit Line (dBµV/m), Read Level (dBµV), Antenna Factor (dB/m), Cable Loss (dB), Preamp Factor (dB), Ant Pos (cm), Table Pos (deg), Peak Avg. (P/A), Pol. (H/V). Rows include test data for 802.11n HT40 CH 03 2422MHz and a Remark section.



**2.4GHz 2400~2483.5MHz
WIFI 802.11n HT40 (Harmonic @ 3m)**

WIFI Ant. 1	Note	Frequency (MHz)	Level (dBμV/m)	Over Limit (dB)	Limit Line (dBμV/m)	Read Level (dBμV)	Antenna Factor (dB/m)	Cable Loss (dB)	Preamp Factor (dB)	Ant Pos (cm)	Table Pos (deg)	Peak Avg. (P/A)	Pol. (H/V)
802.11n HT40 CH 03		4844	39.41	-34.59	74	59.17	31.82	6.18	58.29	100	0	P	H
		7266	43.67	-30.33	74	57.56	37.07	7.73	59.07	100	0	P	H
													H
													H
2422MHz		4844	39.38	-34.62	74	59.14	31.82	6.18	58.29	100	0	P	V
		7266	44.24	-29.76	74	58.13	37.07	7.73	59.07	100	0	P	V
													V
													V
Remark	1. No other spurious found. 2. All results are PASS against Peak and Average limit line.												



Note symbol

*	Fundamental Frequency which can be ignored. However, the level of any unwanted emissions shall not exceed the level of the fundamental frequency.
!	Test result is over limit line.
P/A	Peak or Average
H/V	Horizontal or Vertical



A calculation example for radiated spurious emission is shown as below:

WIFI	Note	Frequency	Level	Over	Limit	Read	Antenna	Cable	Preamp	Ant	Table	Peak	Pol.
Ant.				Limit	Line	Level	Factor	Loss	Factor	Pos	Pos	Avg.	
1		(MHz)	(dBμV/m)	(dB)	(dBμV/m)	(dBμV)	(dB/m)	(dB)	(dB)	(cm)	(deg)	(P/A)	(H/V)
802.11b		2390	55.45	-18.55	74	54.51	32.22	4.58	35.86	103	308	P	H
CH 01													
2412MHz		2390	43.54	-10.46	54	42.6	32.22	4.58	35.86	103	308	A	H

- Level(dBμV/m) =
Antenna Factor(dB/m) + Cable Loss(dB) + Read Level(dBμV) - Preamp Factor(dB)
- Over Limit(dB) = Level(dBμV/m) – Limit Line(dBμV/m)

For Peak Limit @ 2390MHz:

- Level(dBμV/m)
= Antenna Factor(dB/m) + Cable Loss(dB) + Read Level(dBμV) - Preamp Factor(dB)
= 32.22(dB/m) + 4.58(dB) + 54.51(dBμV) – 35.86 (dB)
= 55.45 (dBμV/m)
- Over Limit(dB)
= Level(dBμV/m) – Limit Line(dBμV/m)
= 55.45(dBμV/m) – 74(dBμV/m)
= -18.55(dB)

For Average Limit @ 2390MHz:

- Level(dBμV/m)
= Antenna Factor(dB/m) + Cable Loss(dB) + Read Level(dBμV) - Preamp Factor(dB)
= 32.22(dB/m) + 4.58(dB) + 42.6(dBμV) – 35.86 (dB)
= 43.54 (dBμV/m)
- Over Limit(dB)
= Level(dBμV/m) – Limit Line(dBμV/m)
= 43.54(dBμV/m) – 54(dBμV/m)
= -10.46(dB)

Both peak and average measured complies with the limit line, so test result is “PASS”.



Appendix A. Radiated Spurious Emission

Test Engineer :	Ray Chen, J.C. Liang and Nick Yu	Temperature :	23~25°C
		Relative Humidity :	59~63%

<CDD Mode>

2.4GHz 2400~2483.5MHz
WIFI 802.11b (Band Edge @ 3m)

WIFI Ant. 1+2	Note	Frequency (MHz)	Level (dBμV/m)	Over Limit (dB)	Limit Line (dBμV/m)	Read Level (dBμV)	Antenna Factor (dB/m)	Cable Loss (dB)	Preamp Factor (dB)	Ant Pos (cm)	Table Pos (deg)	Peak Avg. (P/A)	Pol. (H/V)	
802.11b CH 01 2412MHz		2389.485	53.94	-20.06	74	44	27.37	4.03	31.49	397	27	P	H	
		2390	43.46	-10.54	54	33.52	27.37	4.03	31.49	397	27	A	H	
	*	2412	101.72	-	-	91.71	27.42	4.05	31.49	397	27	P	H	
	*	2412	97.32	-	-	87.31	27.42	4.05	31.49	397	27	A	H	
													H	
														H
			2390	57.69	-16.31	74	47.75	27.37	4.03	31.49	228	333	P	V
			2390	50.64	-3.36	54	40.7	27.37	4.03	31.49	228	333	A	V
	*		2412	110.88	-	-	100.87	27.42	4.05	31.49	228	333	P	V
	*		2412	106.49	-	-	96.48	27.42	4.05	31.49	228	333	A	V
														V
														V
Remark	1. No other spurious found. 2. All results are PASS against Peak and Average limit line.													



2.4GHz 2400~2483.5MHz

WIFI 802.11b (Harmonic @ 3m)

WIFI Ant. 1+2	Note	Frequency (MHz)	Level (dBμV/m)	Over Limit (dB)	Limit Line (dBμV/m)	Read Level (dBμV)	Antenna Factor (dB/m)	Cable Loss (dB)	Preamp Factor (dB)	Ant Pos (cm)	Table Pos (deg)	Peak Avg. (P/A)	Pol. (H/V)	
802.11b CH 01 2412MHz		4824	40.85	-33.15	74	60.67	31.79	6.17	58.31	100	0	P	H	
													H	
													H	
													H	
			4824	45.57	-28.43	74	65.39	31.79	6.17	58.31	100	0	P	V
														V
														V
Remark	1. No other spurious found. 2. All results are PASS against Peak and Average limit line.													



**2.4GHz 2400~2483.5MHz
WIFI 802.11g (Band Edge @ 3m)**

WIFI Ant. 1+2	Note	Frequency (MHz)	Level (dBμV/m)	Over Limit (dB)	Limit Line (dBμV/m)	Read Level (dBμV)	Antenna Factor (dB/m)	Cable Loss (dB)	Preamp Factor (dB)	Ant Pos (cm)	Table Pos (deg)	Peak Avg. (P/A)	Pol. (H/V)
802.11g CH 11 2462MHz	*	2462	103.04	-	-	92.81	27.59	4.08	31.47	332	40	P	H
	*	2462	93.59	-	-	83.36	27.59	4.08	31.47	332	40	A	H
		2483.76	54.8	-19.2	74	44.49	27.64	4.11	31.47	332	40	P	H
		2483.64	43.12	-10.88	54	32.81	27.64	4.11	31.47	332	40	A	H
													H
													H
	*	2458	114.38	-	-	104.15	27.59	4.08	31.47	220	11	P	V
	*	2458	104.26	-	-	94.03	27.59	4.08	31.47	220	11	A	V
		2483.84	65.29	-8.71	74	54.98	27.64	4.11	31.47	220	11	P	V
		2483.6	51.96	-2.04	54	41.65	27.64	4.11	31.47	220	11	A	V
													V
													V
Remark	1. No other spurious found. 2. All results are PASS against Peak and Average limit line.												



**2.4GHz 2400~2483.5MHz
WIFI 802.11g (Harmonic @ 3m)**

WIFI Ant. 1+2	Note	Frequency (MHz)	Level (dBμV/m)	Over Limit (dB)	Limit Line (dBμV/m)	Read Level (dBμV)	Antenna Factor (dB/m)	Cable Loss (dB)	Preamp Factor (dB)	Ant Pos (cm)	Table Pos (deg)	Peak Avg. (P/A)	Pol. (H/V)	
802.11g CH 11 2462MHz		4924	38.56	-35.44	74	58.03	31.98	6.23	58.18	100	0	P	H	
		7386	44.47	-29.53	74	58.19	37.41	7.72	59.14	100	0	P	H	
													H	
													H	
			4924	39.61	-34.39	74	59.08	31.98	6.23	58.18	100	0	P	V
			7386	44.4	-29.6	74	58.12	37.41	7.72	59.14	100	0	P	V
														V
														V
Remark	1. No other spurious found. 2. All results are PASS against Peak and Average limit line.													



**2.4GHz 2400~2483.5MHz
WIFI 802.11n HT20 (Band Edge @ 3m)**

WIFI Ant. 1+2	Note	Frequency (MHz)	Level (dBμV/m)	Over Limit (dB)	Limit Line (dBμV/m)	Read Level (dBμV)	Antenna Factor (dB/m)	Cable Loss (dB)	Preamp Factor (dB)	Ant Pos (cm)	Table Pos (deg)	Peak Avg. (P/A)	Pol. (H/V)
802.11n HT20 CH 11 2462MHz	*	2462	101.21	-	-	90.98	27.59	4.08	31.47	301	43	P	H
	*	2462	92.15	-	-	81.92	27.59	4.08	31.47	301	43	A	H
		2484.88	54.34	-19.66	74	44.03	27.64	4.11	31.47	301	43	P	H
		2484.48	43.06	-10.94	54	32.75	27.64	4.11	31.47	301	43	A	H
													H
													H
	*	2462	112.16	-	-	101.93	27.59	4.08	31.47	217	14	P	V
	*	2462	102.81	-	-	92.58	27.59	4.08	31.47	217	14	A	V
		2483.6	66.38	-7.62	74	56.07	27.64	4.11	31.47	217	14	P	V
		2483.52	52.14	-1.86	54	41.83	27.64	4.11	31.47	217	14	A	V
												V	
												V	
Remark	1. No other spurious found. 2. All results are PASS against Peak and Average limit line.												



**2.4GHz 2400~2483.5MHz
WIFI 802.11n HT20 (Harmonic @ 3m)**

WIFI Ant. 1+2	Note	Frequency (MHz)	Level (dBμV/m)	Over Limit (dB)	Limit Line (dBμV/m)	Read Level (dBμV)	Antenna Factor (dB/m)	Cable Loss (dB)	Preamp Factor (dB)	Ant Pos (cm)	Table Pos (deg)	Peak Avg. (P/A)	Pol. (H/V)	
802.11n HT20 CH 11 2462MHz		4924	39.04	-34.96	74	58.51	31.98	6.23	58.18	100	0	P	H	
		7386	45	-29	74	58.72	37.41	7.72	59.14	100	0	P	H	
													H	
													H	
			4924	39.35	-34.65	74	58.82	31.98	6.23	58.18	100	0	P	V
			7386	44.46	-29.54	74	58.18	37.41	7.72	59.14	100	0	P	V
														V
														V
Remark	1. No other spurious found. 2. All results are PASS against Peak and Average limit line.													



**2.4GHz 2400~2483.5MHz
WIFI 802.11n HT40 (Band Edge @ 3m)**

WIFI Ant. 1+2	Note	Frequency (MHz)	Level (dBμV/m)	Over Limit (dB)	Limit Line (dBμV/m)	Read Level (dBμV)	Antenna Factor (dB/m)	Cable Loss (dB)	Preamp Factor (dB)	Ant Pos (cm)	Table Pos (deg)	Peak Avg. (P/A)	Pol. (H/V)
802.11n HT40 CH 03 2422MHz		2389.94	53.65	-20.35	74	43.71	27.37	4.03	31.49	347	37	P	H
		2389.66	43.32	-10.68	54	33.38	27.37	4.03	31.49	347	37	A	H
	*	2422	94.64	-	-	84.56	27.48	4.05	31.48	347	37	P	H
	*	2422	85.02	-	-	74.94	27.48	4.05	31.48	347	37	A	H
		2495.45	52.45	-21.55	74	42.07	27.7	4.11	31.46	347	37	P	H
		2484.88	42.12	-11.88	54	31.81	27.64	4.11	31.47	347	37	A	H
		2389.94	64.96	-9.04	74	55.02	27.37	4.03	31.49	231	343	P	V
		2389.8	52.99	-1.01	54	43.05	27.37	4.03	31.49	231	343	A	V
	*	2422	104.93	-	-	94.85	27.48	4.05	31.48	231	343	P	V
	*	2422	95.49	-	-	85.41	27.48	4.05	31.48	231	343	A	V
		2483.83	53	-21	74	42.69	27.64	4.11	31.47	231	343	P	V
		2484.6	42.97	-11.03	54	32.66	27.64	4.11	31.47	231	343	A	V
Remark	1. No other spurious found. 2. All results are PASS against Peak and Average limit line.												



**2.4GHz 2400~2483.5MHz
WIFI 802.11n HT40 (Harmonic @ 3m)**

WIFI Ant. 1+2	Note	Frequency (MHz)	Level (dBμV/m)	Over Limit (dB)	Limit Line (dBμV/m)	Read Level (dBμV)	Antenna Factor (dB/m)	Cable Loss (dB)	Preamp Factor (dB)	Ant Pos (cm)	Table Pos (deg)	Peak Avg. (P/A)	Pol. (H/V)
802.11n HT40 CH 03		4844	39.63	-34.37	74	59.39	31.82	6.18	58.29	100	0	P	H
		7266	44.75	-29.25	74	58.64	37.07	7.73	59.07	100	0	P	H
													H
													H
2422MHz		4844	39.2	-34.8	74	58.96	31.82	6.18	58.29	100	0	P	V
		7266	44.81	-29.19	74	58.7	37.07	7.73	59.07	100	0	P	V
													V
													V
Remark	1. No other spurious found. 2. All results are PASS against Peak and Average limit line.												



Note symbol

*	Fundamental Frequency which can be ignored. However, the level of any unwanted emissions shall not exceed the level of the fundamental frequency.
!	Test result is over limit line.
P/A	Peak or Average
H/V	Horizontal or Vertical



A calculation example for radiated spurious emission is shown as below:

WIFI	Note	Frequency	Level	Over	Limit	Read	Antenna	Cable	Preamp	Ant	Table	Peak	Pol.
Ant.				Limit	Line	Level	Factor	Loss	Factor	Pos	Pos	Avg.	
1+2		(MHz)	(dBμV/m)	(dB)	(dBμV/m)	(dBμV)	(dB/m)	(dB)	(dB)	(cm)	(deg)	(P/A)	(H/V)
802.11b		2390	55.45	-18.55	74	54.51	32.22	4.58	35.86	103	308	P	H
CH 01													
2412MHz		2390	43.54	-10.46	54	42.6	32.22	4.58	35.86	103	308	A	H

1. Level(dBμV/m) =

$$\text{Antenna Factor(dB/m)} + \text{Cable Loss(dB)} + \text{Read Level(dBμV)} - \text{Preamp Factor(dB)}$$

2. Over Limit(dB) = Level(dBμV/m) – Limit Line(dBμV/m)

For Peak Limit @ 2390MHz:

1. Level(dBμV/m)

$$= \text{Antenna Factor(dB/m)} + \text{Cable Loss(dB)} + \text{Read Level(dBμV)} - \text{Preamp Factor(dB)}$$

$$= 32.22(\text{dB/m}) + 4.58(\text{dB}) + 54.51(\text{dBμV}) - 35.86(\text{dB})$$

$$= 55.45(\text{dBμV/m})$$

2. Over Limit(dB)

$$= \text{Level(dBμV/m)} - \text{Limit Line(dBμV/m)}$$

$$= 55.45(\text{dBμV/m}) - 74(\text{dBμV/m})$$

$$= -18.55(\text{dB})$$

For Average Limit @ 2390MHz:

1. Level(dBμV/m)

$$= \text{Antenna Factor(dB/m)} + \text{Cable Loss(dB)} + \text{Read Level(dBμV)} - \text{Preamp Factor(dB)}$$

$$= 32.22(\text{dB/m}) + 4.58(\text{dB}) + 42.6(\text{dBμV}) - 35.86(\text{dB})$$

$$= 43.54(\text{dBμV/m})$$

2. Over Limit(dB)

$$= \text{Level(dBμV/m)} - \text{Limit Line(dBμV/m)}$$

$$= 43.54(\text{dBμV/m}) - 54(\text{dBμV/m})$$

$$= -10.46(\text{dB})$$

Both peak and average measured complies with the limit line, so test result is "PASS".



Appendix A. Radiated Spurious Emission

Test Engineer :	Ray Chen, J.C. Liang and Nick Yu	Temperature :	23~25°C
		Relative Humidity :	59~63%

<TXBF Mode>

2.4GHz 2400~2483.5MHz

WIFI 802.11n HT20 (Band Edge @ 3m)

WIFI Ant. 1+2	Note	Frequency (MHz)	Level (dBμV/m)	Over Limit (dB)	Limit Line (dBμV/m)	Read Level (dBμV)	Antenna Factor (dB/m)	Cable Loss (dB)	Preamp Factor (dB)	Ant Pos (cm)	Table Pos (deg)	Peak Avg. (P/A)	Pol. (H/V)	
802.11n HT20 CH 01 2412MHz		2389.905	54.59	-19.41	74	44.65	27.37	4.03	31.49	315	358	P	H	
		2390	43.54	-10.46	54	33.6	27.37	4.03	31.49	315	358	A	H	
	*	2412	99.1	-	-	89.09	27.42	4.05	31.49	315	358	P	H	
	*	2412	89.05	-	-	79.04	27.42	4.05	31.49	315	358	A	H	
													H	
														H
			2389.17	65.92	-8.08	74	55.98	27.37	4.03	31.49	154	3	P	V
			2390	52.18	-1.82	54	42.24	27.37	4.03	31.49	154	3	A	V
		*	2412	113.71	-	-	103.7	27.42	4.05	31.49	154	3	P	V
		*	2412	103.72	-	-	93.71	27.42	4.05	31.49	154	3	A	V
													V	
													V	
Remark	1. No other spurious found. 2. All results are PASS against Peak and Average limit line.													



**2.4GHz 2400~2483.5MHz
WIFI 802.11n HT20 (Harmonic @ 3m)**

WIFI Ant. 1+2	Note	Frequency (MHz)	Level (dBμV/m)	Over Limit (dB)	Limit Line (dBμV/m)	Read Level (dBμV)	Antenna Factor (dB/m)	Cable Loss (dB)	Preamp Factor (dB)	Ant Pos (cm)	Table Pos (deg)	Peak Avg. (P/A)	Pol. (H/V)
802.11n HT20 CH 01		4824	38.17	-35.83	74	57.99	31.79	6.17	58.31	100	0	P	H
													H
													H
													H
2412MHz		4824	39.3	-34.7	74	59.12	31.79	6.17	58.31	100	0	P	V
													V
													V
Remark	1. No other spurious found. 2. All results are PASS against Peak and Average limit line.												



2.4GHz 2400~2483.5MHz
WIFI 802.11n HT40 (Band Edge @ 3m)

Table with 14 columns: WIFI Ant. 1+2, Note, Frequency (MHz), Level (dBµV/m), Over Limit (dB), Limit Line (dBµV/m), Read Level (dBµV), Antenna Factor (dB/m), Cable Loss (dB), Preamp Factor (dB), Ant Pos (cm), Table Pos (deg), Peak Avg. (P/A), Pol. (H/V). Rows include test data for 802.11n HT40 CH 03 2422MHz and a Remark section.



**2.4GHz 2400~2483.5MHz
WIFI 802.11n HT40 (Harmonic @ 3m)**

WIFI Ant. 1+2	Note	Frequency (MHz)	Level (dBμV/m)	Over Limit (dB)	Limit Line (dBμV/m)	Read Level (dBμV)	Antenna Factor (dB/m)	Cable Loss (dB)	Preamp Factor (dB)	Ant Pos (cm)	Table Pos (deg)	Peak Avg. (P/A)	Pol. (H/V)
802.11n HT40 CH 03		4844	39.85	-34.15	74	59.61	31.82	6.18	58.29	100	0	P	H
		7266	43.89	-30.11	74	57.78	37.07	7.73	59.07	100	0	P	H
													H
													H
2422MHz		4844	38.8	-35.2	74	58.56	31.82	6.18	58.29	100	0	P	V
		7266	43.95	-30.05	74	57.84	37.07	7.73	59.07	100	0	P	V
													V
													V
Remark	1. No other spurious found. 2. All results are PASS against Peak and Average limit line.												



Note symbol

*	Fundamental Frequency which can be ignored. However, the level of any unwanted emissions shall not exceed the level of the fundamental frequency.
!	Test result is over limit line.
P/A	Peak or Average
H/V	Horizontal or Vertical



A calculation example for radiated spurious emission is shown as below:

WIFI	Note	Frequency	Level	Over	Limit	Read	Antenna	Cable	Preamp	Ant	Table	Peak	Pol.
Ant.				Limit	Line	Level	Factor	Loss	Factor	Pos	Pos	Avg.	
1+2		(MHz)	(dBμV/m)	(dB)	(dBμV/m)	(dBμV)	(dB/m)	(dB)	(dB)	(cm)	(deg)	(P/A)	(H/V)
802.11b		2390	55.45	-18.55	74	54.51	32.22	4.58	35.86	103	308	P	H
CH 01													
2412MHz		2390	43.54	-10.46	54	42.6	32.22	4.58	35.86	103	308	A	H

1. $Level(dB\mu V/m) =$

$Antenna\ Factor(dB/m) + Cable\ Loss(dB) + Read\ Level(dB\mu V) - Preamp\ Factor(dB)$

2. $Over\ Limit(dB) = Level(dB\mu V/m) - Limit\ Line(dB\mu V/m)$

For Peak Limit @ 2390MHz:

1. $Level(dB\mu V/m)$

$= Antenna\ Factor(dB/m) + Cable\ Loss(dB) + Read\ Level(dB\mu V) - Preamp\ Factor(dB)$

$= 32.22(dB/m) + 4.58(dB) + 54.51(dB\mu V) - 35.86(dB)$

$= 55.45(dB\mu V/m)$

2. $Over\ Limit(dB)$

$= Level(dB\mu V/m) - Limit\ Line(dB\mu V/m)$

$= 55.45(dB\mu V/m) - 74(dB\mu V/m)$

$= -18.55(dB)$

For Average Limit @ 2390MHz:

1. $Level(dB\mu V/m)$

$= Antenna\ Factor(dB/m) + Cable\ Loss(dB) + Read\ Level(dB\mu V) - Preamp\ Factor(dB)$

$= 32.22(dB/m) + 4.58(dB) + 42.6(dB\mu V) - 35.86(dB)$

$= 43.54(dB\mu V/m)$

2. $Over\ Limit(dB)$

$= Level(dB\mu V/m) - Limit\ Line(dB\mu V/m)$

$= 43.54(dB\mu V/m) - 54(dB\mu V/m)$

$= -10.46(dB)$

Both peak and average measured complies with the limit line, so test result is "PASS".



Appendix B. Radiated Spurious Emission Plots

Test Engineer :	Ray Chen, J.C. Liang and Nick Yu	Temperature :	23~25°C
		Relative Humidity :	59~63%

Note symbol

-L	Low channel location
-R	High channel location



2.4GHz 2400~2483.5MHz
WIFI 802.11b (Band Edge @ 3m)

WIFI	2.4GHz 2400~2483.5MHz Band Edge @ 3m	
ANT	802.11b CH01 2412MHz	
1	Horizontal	Fundamental
Peak	<p>Site : 03CH12-HY Condition : PEAK_BE_74 3m HORN_9120D_1328 HORIZONTAL Detector : REW:1000.000kHz YBW:3000.000kHz SWT:Auto Project : Peak Mode : 790120-02 :5</p>	<p>Site : 03CH12-HY Condition : PEAK_74 3m HORN_9120D_1328 HORIZONTAL Detector : REW:1000.000kHz YBW:3000.000kHz SWT:Auto Project : Peak Mode : 790120-02 :5</p>
Avg.	<p>Site : 03CH12-HY Condition : AVG_BE_54 3m HORN_9120D_1328 HORIZONTAL Detector : REW:1000.000kHz YBW:0.010kHz SWT:Auto Project : Peak Mode : 790120-02 :5</p>	<p>Site : 03CH12-HY Condition : AVG_54 3m HORN_9120D_1328 HORIZONTAL Detector : REW:1000.000kHz YBW:0.010kHz SWT:Auto Project : Peak Mode : 790120-02 :5</p>

WIFI	2.4GHz 2400~2483.5MHz Band Edge @ 3m
------	--------------------------------------

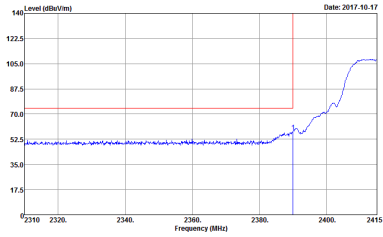
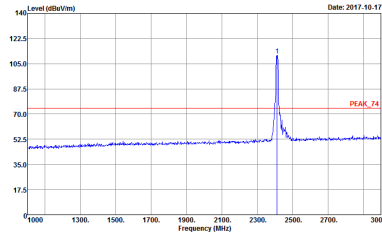
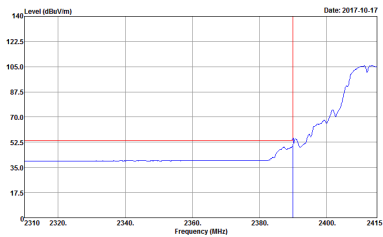
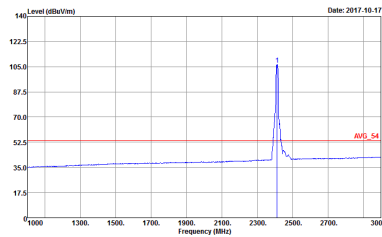

ANT	802.11b CH01 2412MHz	
1	Vertical	Fundamental
Peak	 <p>Site : 03CH12-HY Condition : PEAK_BE_74 3m HORN_9120D_1328 VERTICAL RBW:1000.000KHz VBW:3000.000KHz SWT:Auto Detector : Peak Project : 790120-02 Mode : S</p>	 <p>Site : 03CH12-HY Condition : PEAK_74 3m HORN_9120D_1328 VERTICAL RBW:1000.000KHz VBW:3000.000KHz SWT:Auto Detector : Peak Project : 790120-02 Mode : S</p>
Avg.	 <p>Site : 03CH12-HY Condition : AVG_BE_54 3m HORN_9120D_1328 VERTICAL RBW:1000.000KHz VBW:0.010KHz SWT:Auto Detector : Peak Project : 790120-02 Mode : S</p>	 <p>Site : 03CH12-HY Condition : AVG_54 3m HORN_9120D_1328 VERTICAL RBW:1000.000KHz VBW:0.010KHz SWT:Auto Detector : Peak Project : 790120-02 Mode : S</p>

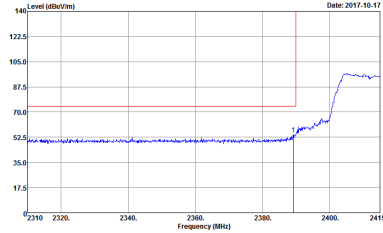
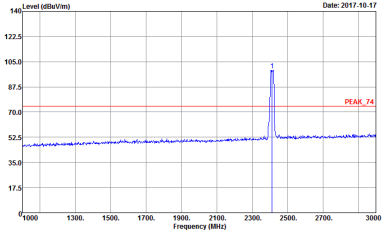
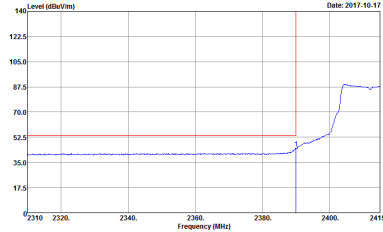
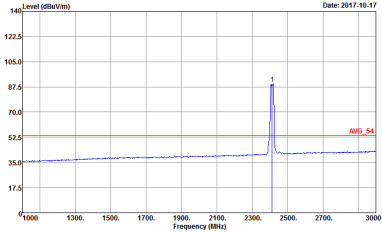

2.4GHz 2400~2483.5MHz
 WIFI 802.11g (Band Edge @ 3m)

WIFI	2.4GHz 2400~2483.5MHz Band Edge @ 3m	
ANT	802.11g CH01 2412MHz	
1	Horizontal	Fundamental
Peak	 <p>Site : 03CH12-HY Condition : PEAK_BE_74 3m HORN_9120D_1328 HORIZONTAL Detector : REW:1000.000kHz YBW:3000.000kHz SWT:Auto Project : Peak Mode : 790120-02 : 6</p>	 <p>Site : 03CH12-HY Condition : PEAK_74 3m HORN_9120D_1328 HORIZONTAL Detector : REW:1000.000kHz YBW:3000.000kHz SWT:Auto Project : Peak Mode : 790120-02 : 6</p>
Avg.	 <p>Site : 03CH12-HY Condition : AVG_BE_54 3m HORN_9120D_1328 HORIZONTAL Detector : REW:1000.000kHz YBW:3.000kHz SWT:Auto Project : Peak Mode : 790120-02 : 6</p>	 <p>Site : 03CH12-HY Condition : AVG_54 3m HORN_9120D_1328 HORIZONTAL Detector : REW:1000.000kHz YBW:3.000kHz SWT:Auto Project : Peak Mode : 790120-02 : 6</p>

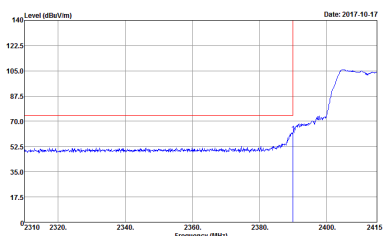
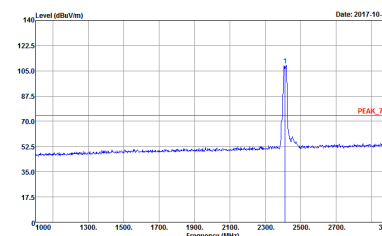
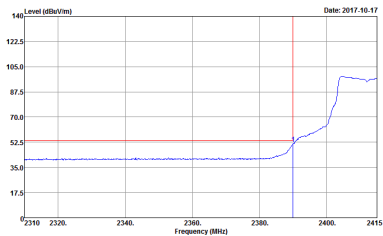
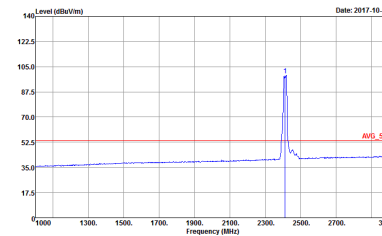

WIFI	2.4GHz 2400~2483.5MHz Band Edge @ 3m	
ANT	802.11g CH01 2412MHz	
1	Vertical	Fundamental
Peak	 <p>Site : 03CH12-HY Condition : PEAK_BE_74 3m HORN_9120D_1328 VERTICAL Detector : RBW:1000.000kHz VBW:3000.000kHz SWT:Auto Project : Peak Mode : 790120-02 :6</p>	 <p>Site : 03CH12-HY Condition : PEAK_74 3m HORN_9120D_1328 VERTICAL Detector : RBW:1000.000kHz VBW:3000.000kHz SWT:Auto Project : Peak Mode : 790120-02 :6</p>
Avg.	 <p>Site : 03CH12-HY Condition : AVG_BE_54 3m HORN_9120D_1328 VERTICAL Detector : RBW:1000.000kHz VBW:3.000kHz SWT:Auto Project : Peak Mode : 790120-02 :6</p>	 <p>Site : 03CH12-HY Condition : AVG_54 3m HORN_9120D_1328 VERTICAL Detector : RBW:1000.000kHz VBW:3.000kHz SWT:Auto Project : Peak Mode : 790120-02 :6</p>



2.4GHz 2400~2483.5MHz

WIFI 802.11n HT20 (Band Edge @ 3m)

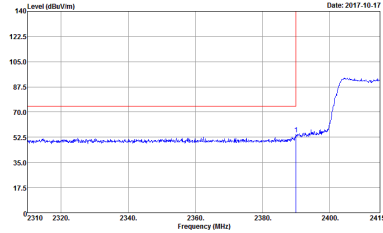
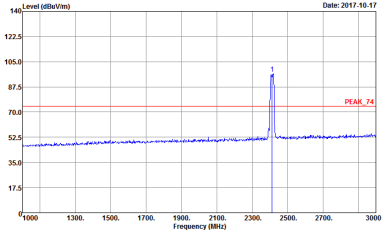
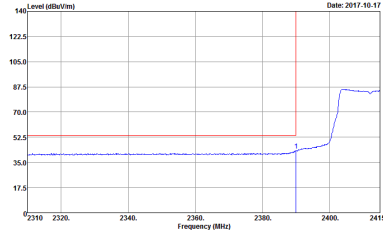
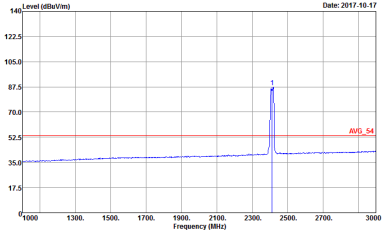
WIFI	2.4GHz 2400~2483.5MHz Band Edge @ 3m	
ANT	802.11n HT20 CH01 2412MHz	
1	Horizontal	Fundamental
Peak	 <p>Site : 03CH12-HY Condition : PEAK_BE_74 3m HORN_9120D_1328 HORIZONTAL Detector : REW:1000.000KHz YBW:3000.000KHz SWT:Auto Project : Peak Mode : 790120-02 7</p>	 <p>Site : 03CH12-HY Condition : PEAK_74 3m HORN_9120D_1328 HORIZONTAL Detector : REW:1000.000KHz YBW:3000.000KHz SWT:Auto Project : Peak Mode : 790120-02 7</p>
Avg.	 <p>Site : 03CH12-HY Condition : AVG_BE_54 3m HORN_9120D_1328 HORIZONTAL Detector : REW:1000.000KHz YBW:3.000KHz SWT:Auto Project : Peak Mode : 790120-02 7</p>	 <p>Site : 03CH12-HY Condition : AVG_54 3m HORN_9120D_1328 HORIZONTAL Detector : REW:1000.000KHz YBW:3.000KHz SWT:Auto Project : Peak Mode : 790120-02 7</p>

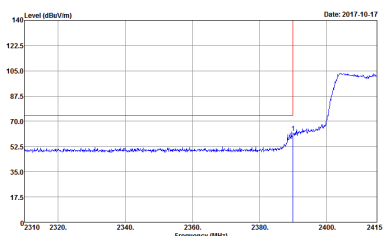
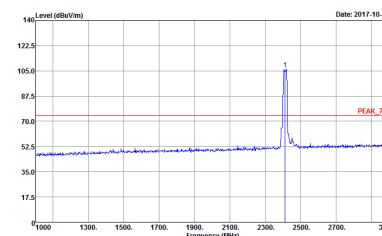
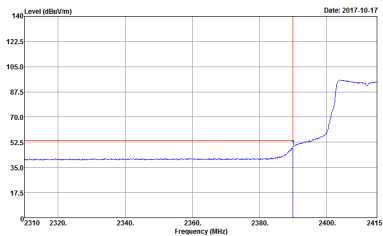
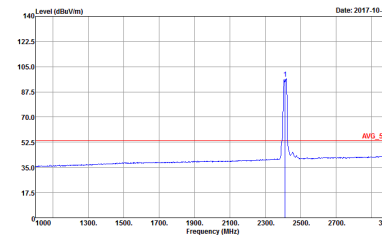

WIFI	2.4GHz 2400~2483.5MHz Band Edge @ 3m	
ANT	802.11n HT20 CH01 2412MHz	
1	Vertical	Fundamental
Peak	 <p>Site: :03CH12-HY Condition: :PEAK_BE_74 3m HORN_9120D_1328 VERTICAL Detector: :RBW:1000.000kHz VBW:3000.000kHz SWT:Auto Project: :Peak Mode: :790120-02 :7</p>	 <p>Site: :03CH12-HY Condition: :PEAK_74 3m HORN_9120D_1328 VERTICAL Detector: :RBW:1000.000kHz VBW:3000.000kHz SWT:Auto Project: :Peak Mode: :790120-02 :7</p>
Avg.	 <p>Site: :03CH12-HY Condition: :AVG_BE_54 3m HORN_9120D_1328 VERTICAL Detector: :RBW:1000.000kHz VBW:3.000kHz SWT:Auto Project: :Peak Mode: :790120-02 :7</p>	 <p>Site: :03CH12-HY Condition: :AVG_54 3m HORN_9120D_1328 VERTICAL Detector: :RBW:1000.000kHz VBW:3.000kHz SWT:Auto Project: :Peak Mode: :790120-02 :7</p>



2.4GHz 2400~2483.5MHz

WIFI 802.11n HT40 (Band Edge @ 3m)

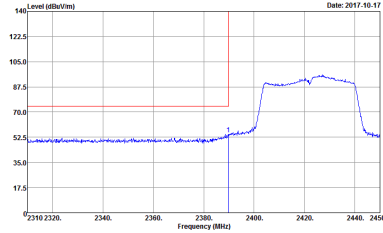
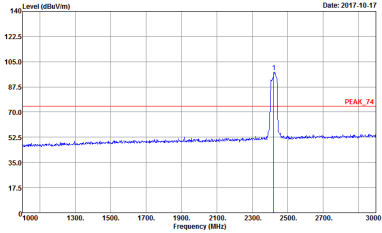
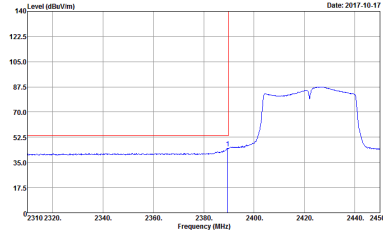
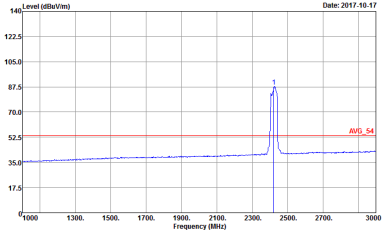
WIFI	2.4GHz 2400~2483.5MHz Band Edge @ 3m	
ANT	802.11n HT40 CH03 2422MHz - L	
1	Horizontal	Fundamental
Peak	 <p>Site : 03CH12-HY Condition : PEAK_BE_74 3m HORN_9120D_1328 HORIZONTAL Detector : REW:1000.000KHz YBW:3000.000KHz SWT:Auto Project : Peak Mode : 790120-02 : 8</p>	 <p>Site : 03CH12-HY Condition : PEAK_74 3m HORN_9120D_1328 HORIZONTAL Detector : REW:1000.000KHz YBW:3000.000KHz SWT:Auto Project : Peak Mode : 790120-02 : 8</p>
Avg.	 <p>Site : 03CH12-HY Condition : AVG_BE_54 3m HORN_9120D_1328 HORIZONTAL Detector : REW:1000.000KHz YBW:3.000KHz SWT:Auto Project : Peak Mode : 790120-02 : 8</p>	 <p>Site : 03CH12-HY Condition : AVG_54 3m HORN_9120D_1328 HORIZONTAL Detector : REW:1000.000KHz YBW:3.000KHz SWT:Auto Project : Peak Mode : 790120-02 : 8</p>

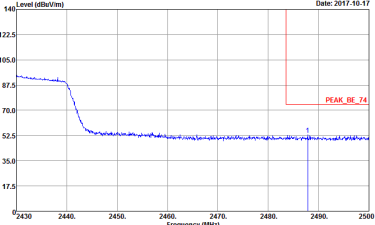
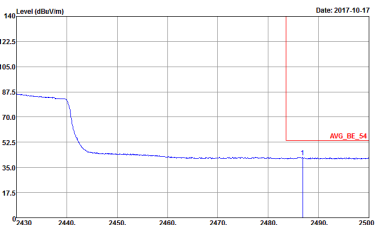

WIFI	2.4GHz 2400~2483.5MHz Band Edge @ 3m	
ANT	802.11n HT40 CH03 2422MHz - R	
1	Horizontal	Fundamental
Peak	 <p>Site : 03CH12-HY Condition : PEAK_BE_74 3m HORN_91200_1328 HORIZONTAL Detector : RBW:1000.000KHz VBW:3000.000KHz SWT:Auto Project : 790120-02 Mode : 8</p>	Left Blank
Avg.	 <p>Site : 03CH12-HY Condition : AVG_BE_54 3m HORN_91200_1328 HORIZONTAL Detector : RBW:1000.000KHz VBW:3.000KHz SWT:Auto Project : 790120-02 Mode : 8</p>	Left Blank

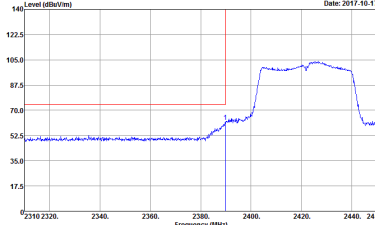
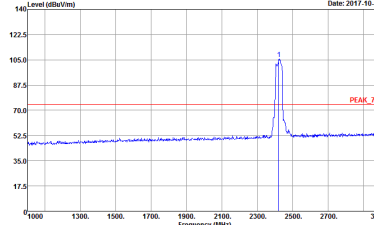
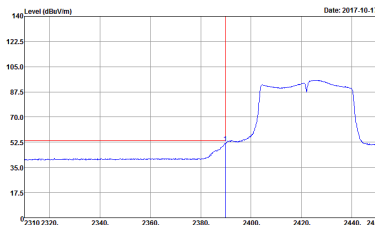
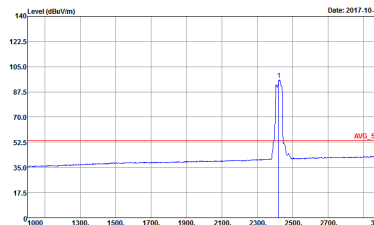

WIFI	2.4GHz 2400~2483.5MHz Band Edge @ 3m	
ANT	802.11n HT40 CH03 2422MHz - L	
1	Vertical	Fundamental
Peak	 <p>Site : 03CH12-HY Condition : PEAK_BE_74 3m HORN_9120D_1328 VERTICAL Detector : RBW:1000.000kHz VBW:3000.000kHz SWT:Auto Project : Peak Mode : 790120-02 :8</p>	 <p>Site : 03CH12-HY Condition : PEAK_74 3m HORN_9120D_1328 VERTICAL Detector : RBW:1000.000kHz VBW:3000.000kHz SWT:Auto Project : Peak Mode : 790120-02 :8</p>
Avg.	 <p>Site : 03CH12-HY Condition : AVG_BE_54 3m HORN_9120D_1328 VERTICAL Detector : RBW:1000.000kHz VBW:3.000kHz SWT:Auto Project : Peak Mode : 790120-02 :8</p>	 <p>Site : 03CH12-HY Condition : AVG_54 3m HORN_9120D_1328 VERTICAL Detector : RBW:1000.000kHz VBW:3.000kHz SWT:Auto Project : Peak Mode : 790120-02 :8</p>

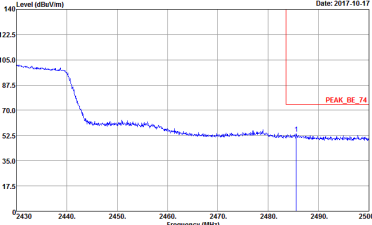
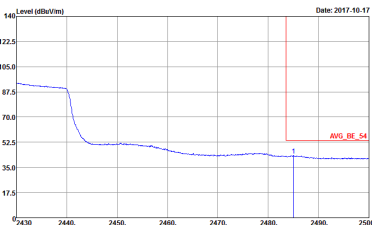

WIFI	2.4GHz 2400~2483.5MHz Band Edge @ 3m	
ANT	802.11n HT40 CH03 2422MHz - R	
1	Vertical	Fundamental
Peak	 <p>Site : 03CH12-HY Condition : PEAK_BE_74 3m HORN_9120D_1338 VERTICAL Detector : RBW:1000.000KHz VBW:3000.000KHz SWT:Auto Project : 790120-02 Mode : 8</p>	Left blank
Avg.	 <p>Site : 03CH12-HY Condition : AVG_BE_54 3m HORN_9120D_1338 VERTICAL Detector : RBW:1000.000KHz VBW:3.000KHz SWT:Auto Project : 790120-02 Mode : 8</p>	Left blank



2.4GHz 2400~2483.5MHz

WIFI 802.11b (Harmonic @ 3m)

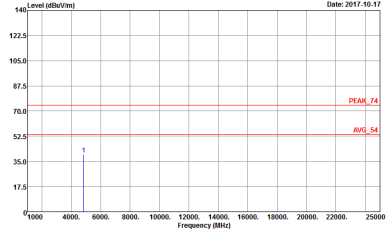
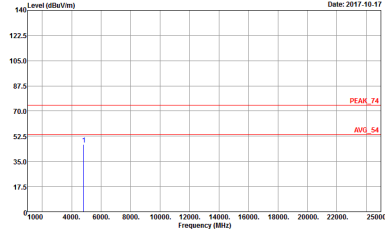
WIFI	2.4GHz 2400~2483.5MHz Harmonic @ 3m	
ANT	802.11b CH01 2412MHz	
1	Horizontal	Vertical
Peak Avg.	 <p>Site : 03CH12-HY Condition : PEAK_74 3m HORN_9120D_1328 HORIZONTAL Detector : Peak Project : 790120-02 Mode : 5</p>	 <p>Site : 03CH12-HY Condition : PEAK_74 3m HORN_9120D_1328 VERTICAL Detector : Peak Project : 790120-02 Mode : 5</p>



2.4GHz 2400~2483.5MHz
 WIFI 802.11g (Harmonic @ 3m)

WIFI	2.4GHz 2400~2483.5MHz Harmonic @ 3m	
ANT	802.11g CH01 2412MHz	
1	Horizontal	Vertical
Peak Avg.	<p>Site : 03CH12-HY Condition : PEAK_74 3m HORN_9120D_1328 HORIZONTAL Detector : Peak Project : 790120-02 Mode : 6</p>	<p>Site : 03CH12-HY Condition : PEAK_74 3m HORN_9120D_1328 VERTICAL Detector : Peak Project : 790120-02 Mode : 6</p>



2.4GHz 2400~2483.5MHz
 WIFI 802.11n HT20 (Harmonic @ 3m)

WIFI	2.4GHz 2400~2483.5MHz Harmonic @ 3m	
ANT	802.11n HT20 CH01 2412MHz	
1	Horizontal	Vertical
Peak Avg.	<p>Site : 03CH12-11Y Condition : PEAK_74 3m HORN_9120D_1328 HORIZONTAL Detector : Peak Project : 790120-02 Mode : 7</p>	<p>Site : 03CH12-11Y Condition : PEAK_74 3m HORN_9120D_1328 VERTICAL Detector : Peak Project : 790120-02 Mode : 7</p>



2.4GHz 2400~2483.5MHz
 WIFI 802.11n HT40 (Harmonic @ 3m)

WIFI	2.4GHz 2400~2483.5MHz Harmonic @ 3m	
ANT	802.11n HT40 CH03 2422MHz	
1	Horizontal	Vertical
Peak Avg.	<p>Site : 03CH12-11Y Condition : PEAK_74 3m HORN_9120D_1328 HORIZONTAL Detector : Peak Project : 790120-02 Mode : 8</p>	<p>Site : 03CH12-11Y Condition : PEAK_74 3m HORN_9120D_1328 VERTICAL Detector : Peak Project : 790120-02 Mode : 8</p>



Appendix B. Radiated Spurious Emission Plots

Test Engineer :	Ray Chen, J.C. Liang and Nick Yu	Temperature :	23~25°C
		Relative Humidity :	59~63%

Note symbol

-L	Low channel location
-R	High channel location



<CDD Mode>

2.4GHz 2400~2483.5MHz
WIFI 802.11b (Band Edge @ 3m)

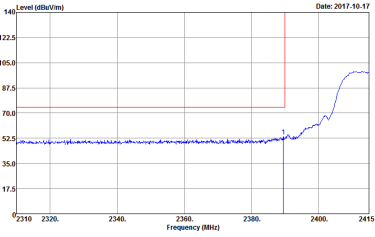
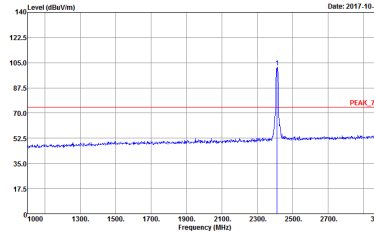
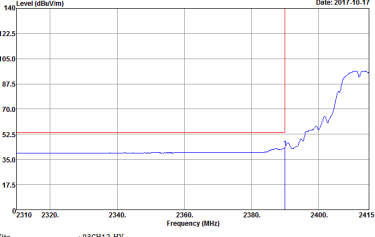
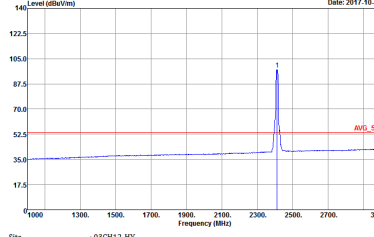
WIFI	2.4GHz 2400~2483.5MHz Band Edge @ 3m	
ANT	802.11b CH01 2412MHz	
1+2	Horizontal	Fundamental
Peak	 <p>Site : 03CH12-HY Condition : PEAK_BE_74 3m HORN_9120D_1328 HORIZONTAL Detector : REW:1000.000kHz VBW:3000.000kHz SWT:Auto Project : Peak Mode : 790120-02 Setting : 1 : 18.5</p>	 <p>Site : 03CH12-HY Condition : PEAK_74 3m HORN_9120D_1328 HORIZONTAL Detector : REW:1000.000kHz VBW:3000.000kHz SWT:Auto Project : Peak Mode : 790120-02 Setting : 1 : 18.5</p>
Avg.	 <p>Site : 03CH12-HY Condition : AVG_BE_54 3m HORN_9120D_1328 HORIZONTAL Detector : REW:1000.000kHz VBW:0.010kHz SWT:Auto Project : Peak Mode : 790120-02 Setting : 1 : 18.5</p>	 <p>Site : 03CH12-HY Condition : AVG_54 3m HORN_9120D_1328 HORIZONTAL Detector : REW:1000.000kHz VBW:0.010kHz SWT:Auto Project : Peak Mode : 790120-02 Setting : 1 : 18.5</p>

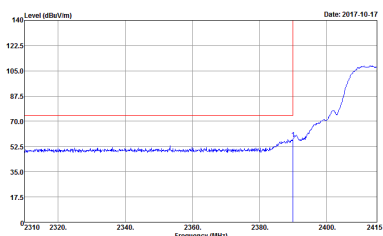
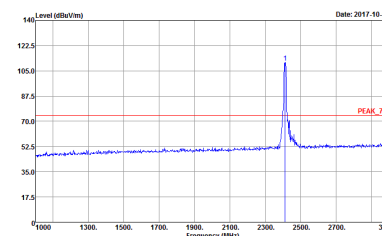
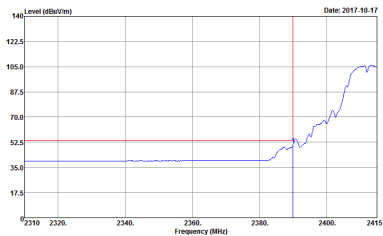
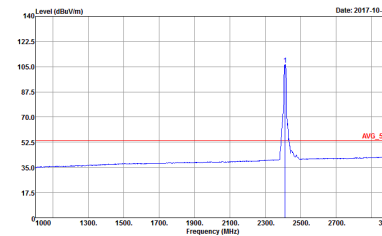

WIFI	2.4GHz 2400~2483.5MHz Band Edge @ 3m	
ANT	802.11b CH01 2412MHz	
1+2	Vertical	Fundamental
Peak	 <p>Site : 03CH12-HY Condition : PEAK_BE_74 3m HORN_9120D_1328 VERTICAL Detector : RBW:1000.000kHz VBW:3000.000kHz SWT:Auto Project : Peak Mode : 790120-02 Setting : 1 : 18.5</p>	 <p>Site : 03CH12-HY Condition : PEAK_74 3m HORN_9120D_1328 VERTICAL Detector : RBW:1000.000kHz VBW:3000.000kHz SWT:Auto Project : Peak Mode : 790120-02 Setting : 1 : 18.5</p>
Avg.	 <p>Site : 03CH12-HY Condition : AVG_BE_54 3m HORN_9120D_1328 VERTICAL Detector : RBW:1000.000kHz VBW:0.010kHz SWT:Auto Project : Peak Mode : 790120-02 Setting : 1 : 18.5</p>	 <p>Site : 03CH12-HY Condition : AVG_54 3m HORN_9120D_1328 VERTICAL Detector : RBW:1000.000kHz VBW:0.010kHz SWT:Auto Project : Peak Mode : 790120-02 Setting : 1 : 18.5</p>

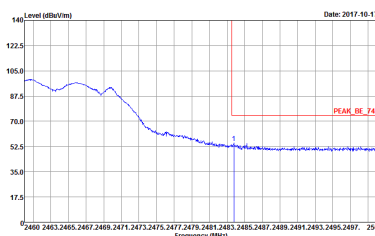
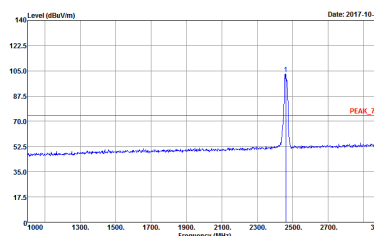
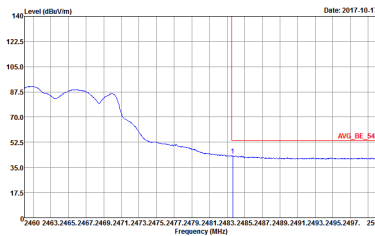
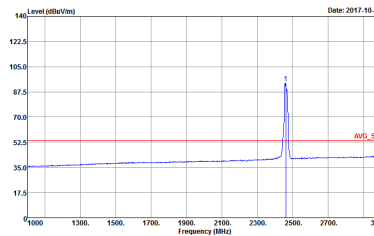

WIFI	2.4GHz 2400~2483.5MHz Band Edge @ 3m	
ANT	802.11g CH11 2462MHz	
1+2	Horizontal	Fundamental
Peak	 <p>Site : 03CH12-HY Condition : PEAK_BE_74 3m HORN_9120D_1328 HORIZONTAL Detector : RBW:1000.000kHz VBW:3000.000kHz SWT:Auto Project : Peak Mode : 790120-02 Setting : 2 -14.5</p>	 <p>Site : 03CH12-HY Condition : PEAK_74 3m HORN_9120D_1328 HORIZONTAL Detector : RBW:1000.000kHz VBW:3000.000kHz SWT:Auto Project : Peak Mode : 790120-02 Setting : 2 -14.5</p>
Avg.	 <p>Site : 03CH12-HY Condition : AVG_BE_54 3m HORN_9120D_1328 HORIZONTAL Detector : RBW:1000.000kHz VBW:3.000kHz SWT:Auto Project : Peak Mode : 790120-02 Setting : 2 -14.5</p>	 <p>Site : 03CH12-HY Condition : AVG_54 3m HORN_9120D_1328 HORIZONTAL Detector : RBW:1000.000kHz VBW:3.000kHz SWT:Auto Project : Peak Mode : 790120-02 Setting : 2 -14.5</p>

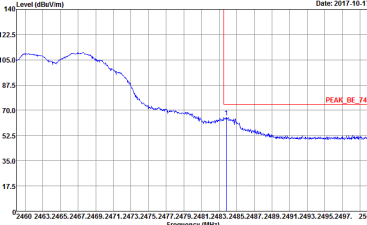
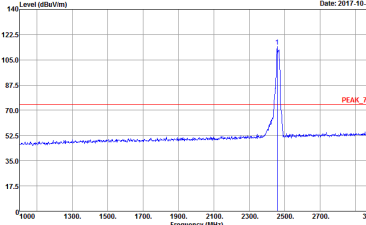
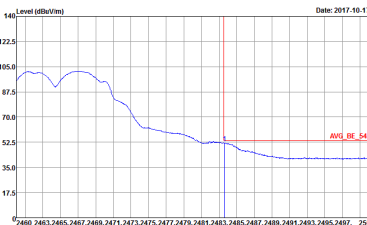
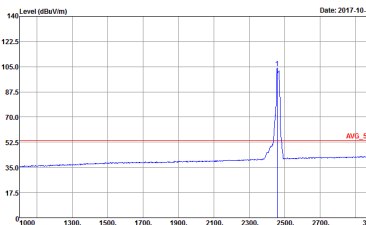

WIFI	2.4GHz 2400~2483.5MHz Band Edge @ 3m	
ANT	802.11g CH11 2462MHz	
1+2	Vertical	Fundamental
Peak	 <p>Level (dBuV/m) vs Frequency (MHz) plot showing a peak at 2462 MHz. The y-axis ranges from 17.5 to 140 dBuV/m, and the x-axis ranges from 2400 to 2500 MHz. A red vertical line marks the peak at 2462 MHz, with a red horizontal line extending to the right labeled 'PEAK_BE_74'.</p> <p>Site: :03CH12-HY Condition: :PEAK_BE_74 3m HORN_9120D_1338 VERTICAL :RBW:1000.000kHz VBW:3000.000kHz SWT:Auto Detector: :Peak Project: :790120-02 Mode: :2 Setting: :14.5</p>	 <p>Level (dBuV/m) vs Frequency (MHz) plot showing a sharp peak at 2462 MHz. The y-axis ranges from 17.5 to 140 dBuV/m, and the x-axis ranges from 1000 to 3000 MHz. A red vertical line marks the peak at 2462 MHz, with a red horizontal line extending to the right labeled 'PEAK_74'.</p> <p>Site: :03CH12-HY Condition: :PEAK_74 3m HORN_9120D_1338 VERTICAL :RBW:1000.000kHz VBW:3000.000kHz SWT:Auto Detector: :Peak Project: :790120-02 Mode: :2 Setting: :14.5</p>
Avg.	 <p>Level (dBuV/m) vs Frequency (MHz) plot showing the average spectrum. The y-axis ranges from 17.5 to 140 dBuV/m, and the x-axis ranges from 2400 to 2500 MHz. A red vertical line marks the peak at 2462 MHz, with a red horizontal line extending to the right labeled 'AVG_BE_54'.</p> <p>Site: :03CH12-HY Condition: :AVG_BE_54 3m HORN_9120D_1338 VERTICAL :RBW:1000.000kHz VBW:3.000kHz SWT:Auto Detector: :Peak Project: :790120-02 Mode: :2 Setting: :14.5</p>	 <p>Level (dBuV/m) vs Frequency (MHz) plot showing the average spectrum. The y-axis ranges from 17.5 to 140 dBuV/m, and the x-axis ranges from 1000 to 3000 MHz. A red vertical line marks the peak at 2462 MHz, with a red horizontal line extending to the right labeled 'AVG_54'.</p> <p>Site: :03CH12-HY Condition: :AVG_54 3m HORN_9120D_1338 VERTICAL :RBW:1000.000kHz VBW:3.000kHz SWT:Auto Detector: :Peak Project: :790120-02 Mode: :2 Setting: :14.5</p>

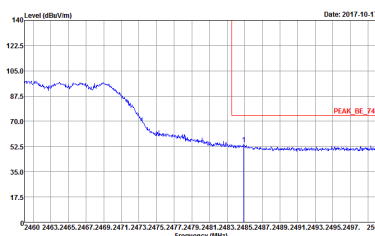
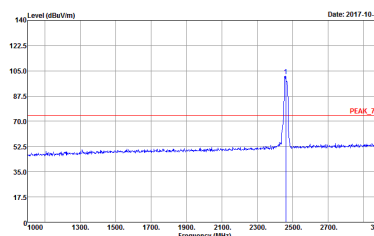
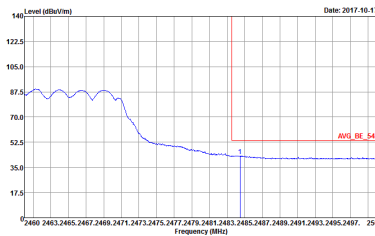
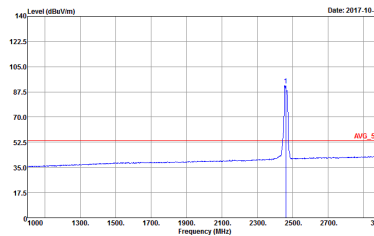

WIFI	2.4GHz 2400~2483.5MHz Band Edge @ 3m	
ANT	802.11n HT20 CH11 2462MHz	
1+2	Horizontal	Fundamental
Peak	 <p>Site : 03CH12-HY Condition : PEAK_BE_74 3m HORN_9120D_1328 HORIZONTAL Detector : RBW:1000.000KHz VBW:3000.000KHz SWT:Auto Project : Peak Mode : 790120-02 Setting : 3 : 14</p>	 <p>Site : 03CH12-HY Condition : PEAK_74 3m HORN_9120D_1328 HORIZONTAL Detector : RBW:1000.000KHz VBW:3000.000KHz SWT:Auto Project : Peak Mode : 790120-02 Setting : 3 : 14</p>
Avg.	 <p>Site : 03CH12-HY Condition : AVG_BE_54 3m HORN_9120D_1328 HORIZONTAL Detector : RBW:1000.000KHz VBW:3.000KHz SWT:Auto Project : Peak Mode : 790120-02 Setting : 3 : 14</p>	 <p>Site : 03CH12-HY Condition : AVG_54 3m HORN_9120D_1328 HORIZONTAL Detector : RBW:1000.000KHz VBW:3.000KHz SWT:Auto Project : Peak Mode : 790120-02 Setting : 3 : 14</p>

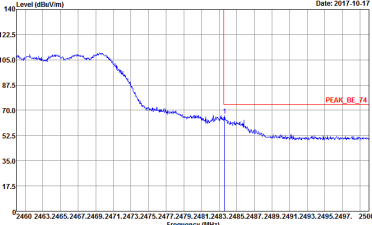
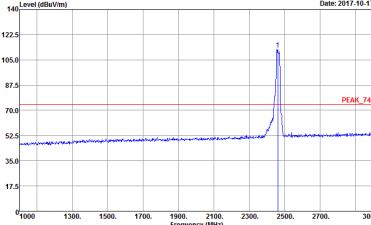
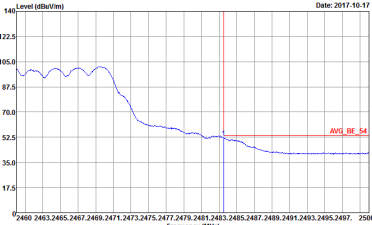
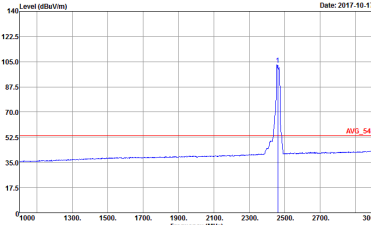

WIFI	2.4GHz 2400~2483.5MHz Fundamental @ 3m	
ANT	802.11n HT20 CH11 2462MHz	
1+2	Vertical	Fundamental
Peak	 <p>Site : 03CH12-HY Condition : PEAK_BE_74 3m HORN_9120D_1338 VERTICAL Detector : RBW:1000.000kHz VBW:3000.000kHz SWT:Auto Project : Peak Mode : 790120-02 Setting : 3 : 14</p>	 <p>Site : 03CH12-HY Condition : PEAK_74 3m HORN_9120D_1338 VERTICAL Detector : RBW:1000.000kHz VBW:3000.000kHz SWT:Auto Project : Peak Mode : 790120-02 Setting : 3 : 14</p>
Avg.	 <p>Site : 03CH12-HY Condition : AVG_BE_54 3m HORN_9120D_1338 VERTICAL Detector : RBW:1000.000kHz VBW:3.000kHz SWT:Auto Project : Peak Mode : 790120-02 Setting : 3 : 14</p>	 <p>Site : 03CH12-HY Condition : AVG_54 3m HORN_9120D_1338 VERTICAL Detector : RBW:1000.000kHz VBW:3.000kHz SWT:Auto Project : Peak Mode : 790120-02 Setting : 3 : 14</p>



2.4GHz 2400~2483.5MHz

WIFI 802.11n HT40 (Band Edge @ 3m)

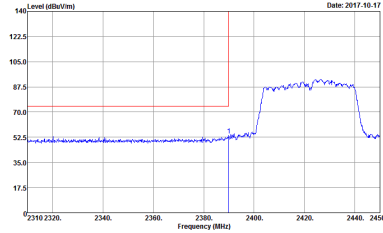
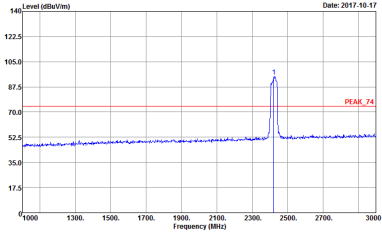
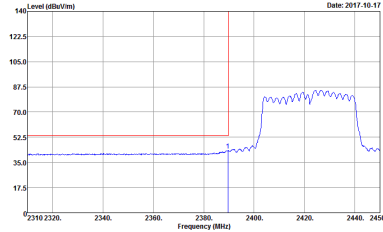
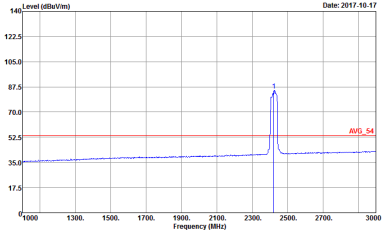
WIFI	2.4GHz 2400~2483.5MHz Band Edge @ 3m	
ANT	802.11n HT40 CH03 2422MHz - L	
1+2	Horizontal	Fundamental
Peak	 <p>Site : 03CH12-HY Condition : PEAK_BE_74 3m HORN_9120D_1328 HORIZONTAL Detector : REW:1000.000kHz YBW:3000.000kHz SWT:Auto Project : Peak Mode : 790120-02 Setting : 4 : 7</p>	 <p>Site : 03CH12-HY Condition : PEAK_74 3m HORN_9120D_1328 HORIZONTAL Detector : REW:1000.000kHz YBW:3000.000kHz SWT:Auto Project : Peak Mode : 790120-02 Setting : 4 : 7</p>
Avg.	 <p>Site : 03CH12-HY Condition : AVG_BE_54 3m HORN_9120D_1328 HORIZONTAL Detector : REW:1000.000kHz YBW:3.000kHz SWT:Auto Project : Peak Mode : 790120-02 Setting : 4 : 7</p>	 <p>Site : 03CH12-HY Condition : AVG_54 3m HORN_9120D_1328 HORIZONTAL Detector : REW:1000.000kHz YBW:3.000kHz SWT:Auto Project : Peak Mode : 790120-02 Setting : 4 : 7</p>



WIFI	2.4GHz 2400~2483.5MHz Band Edge @ 3m	
ANT	802.11n HT40 CH03 2422MHz - R	
1+2	Horizontal	Fundamental
Peak	<p>Site : 03CH12-HY Condition : PEAK_BE_74 3m HORN_91200_1328 HORIZONTAL Detector : RBW:1000.000KHz VBW:3000.000KHz SWT:Auto Project : 790120-02 Mode : 4 Setting : 7</p>	Left Blank
Avg.	<p>Site : 03CH12-HY Condition : AVG_BE_54 3m HORN_91200_1328 HORIZONTAL Detector : RBW:1000.000KHz VBW:3.000KHz SWT:Auto Project : 790120-02 Mode : 4 Setting : 7</p>	Left Blank

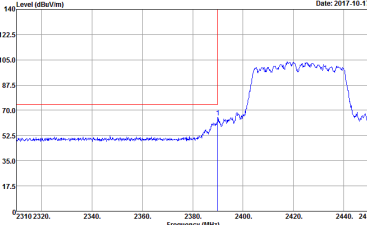
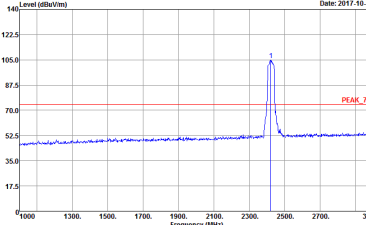
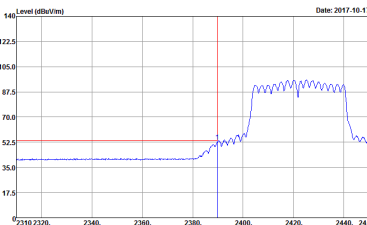
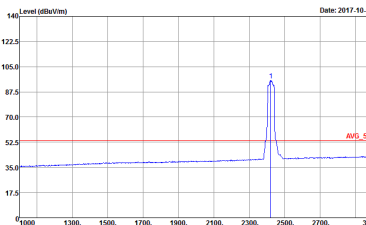

WIFI	2.4GHz 2400~2483.5MHz Band Edge @ 3m	
ANT	802.11n HT40 CH03 2422MHz - L	
1+2	Vertical	Fundamental
Peak	 <p>Site: -03CH12-HY Condition: -PEAK_BE_74 3m HORN_9120D_1328 VERTICAL Detector: -RBW:1000.000kHz VBW:3000.000kHz SWT:Auto Project: -Peak Mode: -790120-02 Setting: -4 -7</p>	 <p>Site: -03CH12-HY Condition: -PEAK_74 3m HORN_9120D_1328 VERTICAL Detector: -RBW:1000.000kHz VBW:3000.000kHz SWT:Auto Project: -Peak Mode: -790120-02 Setting: -4 -7</p>
Avg.	 <p>Site: -03CH12-HY Condition: -AVG_BE_54 3m HORN_9120D_1328 VERTICAL Detector: -RBW:1000.000kHz VBW:3.000kHz SWT:Auto Project: -Peak Mode: -790120-02 Setting: -4 -7</p>	 <p>Site: -03CH12-HY Condition: -AVG_54 3m HORN_9120D_1328 VERTICAL Detector: -RBW:1000.000kHz VBW:3.000kHz SWT:Auto Project: -Peak Mode: -790120-02 Setting: -4 -7</p>

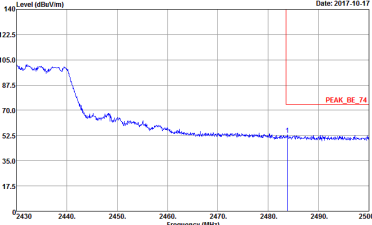
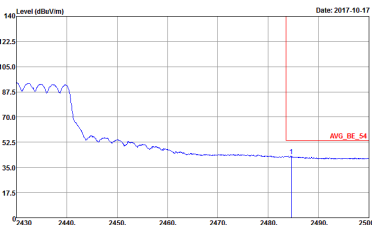

WIFI	2.4GHz 2400~2483.5MHz Band Edge @ 3m	
ANT	802.11n HT40 CH03 2422MHz - R	
1+2	Vertical	Fundamental
<p>Peak</p>	 <p>Date: 2017-10-17</p> <pre> Site : 03CH12-HY Condition : PEAK_BE_74 3m HORN_9120D_1338 VERTICAL : RBW:1000.000KHz VBW:3000.000KHz SWT:Auto Detector : Peak Project : 790120-02 Mode : 4 Setting : 7 </pre>	<p>Left blank</p>
<p>Avg.</p>	 <p>Date: 2017-10-17</p> <pre> Site : 03CH12-HY Condition : AVG_BE_54 3m HORN_9120D_1338 VERTICAL : RBW:1000.000KHz VBW:3.000KHz SWT:Auto Detector : Peak Project : 790120-02 Mode : 4 Setting : 7 </pre>	<p>Left blank</p>



2.4GHz 2400~2483.5MHz
 WIFI 802.11b (Harmonic @ 3m)

WIFI	2.4GHz 2400~2483.5MHz Harmonic @ 3m	
ANT	802.11b CH01 2412MHz	
1+2	Horizontal	Vertical
Peak Avg.	<p>Site : 03CH12-HY Condition : PEAK_74 3m HORN_9120D_1328 HORIZONTAL Detector : Peak Project : 790120-02 Mode : 1 Setting : 10.5</p>	<p>Site : 03CH12-HY Condition : PEAK_74 3m HORN_9120D_1328 VERTICAL Detector : Peak Project : 790120-02 Mode : 1 Setting : 10.5</p>



WIFI	2.4GHz 2400~2483.5MHz Harmonic @ 3m	
ANT	802.11g CH11 2462MHz	
1+2	Horizontal	Vertical
Peak Avg.	<p>Site: -03CH12-HY Condition: PEAK_74 3m HORN_9120D_1328 HORIZONTAL Detector: Peak Project: 790120-02 Mode: 2 Setting: -14.5</p>	<p>Site: -03CH12-HY Condition: PEAK_74 3m HORN_9120D_1328 VERTICAL Detector: Peak Project: 790120-02 Mode: 2 Setting: -14.5</p>



2.4GHz 2400~2483.5MHz
 WIFI 802.11n HT20 (Harmonic @ 3m)

WIFI	2.4GHz 2400~2483.5MHz Harmonic @ 3m	
ANT	802.11n HT20 CH11 2462MHz	
1+2	Horizontal	Vertical
Peak Avg.	<p>Site : 03CH12-HY Condition : PEAK_74 3m HORN_9120D_1328 HORIZONTAL Detector : Peak Project : 790120-02 Mode : 3 Setting : 14</p>	<p>Site : 03CH12-HY Condition : PEAK_74 3m HORN_9120D_1328 VERTICAL Detector : Peak Project : 790120-02 Mode : 3 Setting : 14</p>



2.4GHz 2400~2483.5MHz
 WIFI 802.11n HT40 (Harmonic @ 3m)

WIFI	2.4GHz 2400~2483.5MHz Harmonic @ 3m	
ANT	802.11n HT40 CH03 2422MHz	
1+2	Horizontal	Vertical
Peak Avg.	<p>Site : 03CH12-11Y Condition : PEAK_74 3m HORN_9120D_1328 HORIZONTAL Detector : Peak Project : 790120-02 Mode : 4 Setting : 7</p>	<p>Site : 03CH12-11Y Condition : PEAK_74 3m HORN_9120D_1328 VERTICAL Detector : Peak Project : 790120-02 Mode : 4 Setting : 7</p>



Appendix B. Radiated Spurious Emission Plots

Test Engineer :	Ray Chen, J.C. Liang and Nick Yu	Temperature :	23~25°C
		Relative Humidity :	59~63%

Note symbol

-L	Low channel location
-R	High channel location



<TXBF Mode>

2.4GHz 2400~2483.5MHz

WIFI 802.11n HT20 (Band Edge @ 3m)

WIFI	2.4GHz 2400~2483.5MHz Band Edge @ 3m	
ANT	802.11n HT20 CH01 2412MHz	
1+2	Horizontal	Fundamental
Peak	<p>Site Condition : 03CH12-HY : PEAK_BE_74 3m HORN_9120D_1328 HORIZONTAL : REW:1000.000KHz YBW:3000.000KHz SWT:Auto Detector : Peak Project : 790120-02 Mode : 9 Setting : 13</p>	<p>Site Condition : 03CH12-HY : PEAK_74 3m HORN_9120D_1328 HORIZONTAL : REW:1000.000KHz YBW:3000.000KHz SWT:Auto Detector : Peak Project : 790120-02 Mode : 9 Setting : 13</p>
Avg.	<p>Site Condition : 03CH12-HY : AVG_BE_54 3m HORN_9120D_1328 HORIZONTAL : REW:1000.000KHz YBW:0.300KHz SWT:Auto Detector : Peak Project : 790120-02 Mode : 9 Setting : 13</p>	<p>Site Condition : 03CH12-HY : AVG_54 3m HORN_9120D_1328 HORIZONTAL : REW:1000.000KHz YBW:0.300KHz SWT:Auto Detector : Peak Project : 790120-02 Mode : 9 Setting : 13</p>

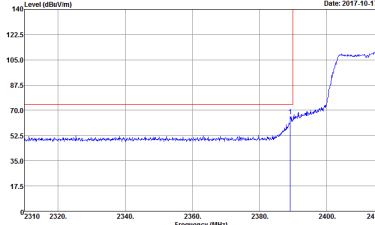
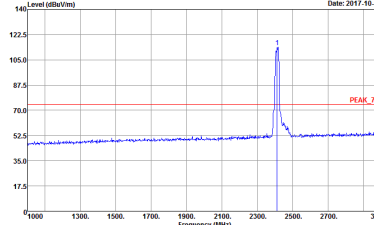
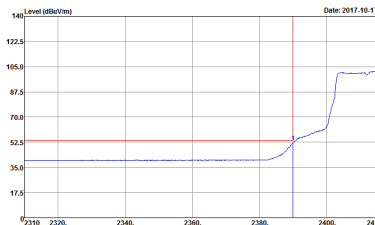
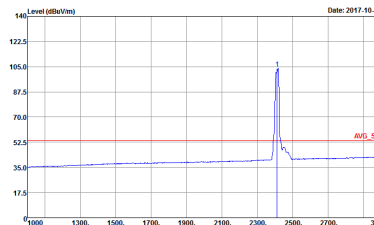

WIFI	2.4GHz 2400~2483.5MHz Band Edge @ 3m	
ANT	802.11n HT20 CH01 2412MHz	
1+2	Vertical	Fundamental
Peak	 <p>Level (dBuV/m) vs Frequency (MHz) plot for Vertical Peak. The y-axis ranges from 17.5 to 140 dBuV/m, and the x-axis ranges from 2310 to 2415 MHz. A red horizontal line is at approximately 70 dBuV/m. A blue curve shows a sharp increase starting around 2380 MHz, reaching about 105 dBuV/m at 2415 MHz. A vertical red line is at 2412 MHz.</p> <pre> Site : 03CH12-HY Condition : PEAK_BE_74 3m HORN_9120D_1328 VERTICAL Detector : RBW:1000.000kHz VBW:3000.000kHz SWT:Auto Project : Peak Mode : 790120-02 Setting : 9 : 13 </pre>	 <p>Level (dBuV/m) vs Frequency (MHz) plot for Fundamental Peak. The y-axis ranges from 17.5 to 140 dBuV/m, and the x-axis ranges from 1000 to 3000 MHz. A red horizontal line is at approximately 70 dBuV/m. A blue curve shows a sharp peak at approximately 2412 MHz, reaching about 105 dBuV/m. A vertical red line is at 2412 MHz.</p> <pre> Site : 03CH12-HY Condition : PEAK_74 3m HORN_9120D_1328 VERTICAL Detector : RBW:1000.000kHz VBW:3000.000kHz SWT:Auto Project : Peak Mode : 790120-02 Setting : 9 : 13 </pre>
Avg.	 <p>Level (dBuV/m) vs Frequency (MHz) plot for Vertical Avg. The y-axis ranges from 17.5 to 140 dBuV/m, and the x-axis ranges from 2310 to 2415 MHz. A red horizontal line is at approximately 70 dBuV/m. A blue curve shows a sharp increase starting around 2380 MHz, reaching about 105 dBuV/m at 2415 MHz. A vertical red line is at 2412 MHz.</p> <pre> Site : 03CH12-HY Condition : AVG_BE_54 3m HORN_9120D_1328 VERTICAL Detector : RBW:1000.000kHz VBW:0.300kHz SWT:Auto Project : Peak Mode : 790120-02 Setting : 9 : 13 </pre>	 <p>Level (dBuV/m) vs Frequency (MHz) plot for Fundamental Avg. The y-axis ranges from 17.5 to 140 dBuV/m, and the x-axis ranges from 1000 to 3000 MHz. A red horizontal line is at approximately 70 dBuV/m. A blue curve shows a sharp peak at approximately 2412 MHz, reaching about 105 dBuV/m. A vertical red line is at 2412 MHz.</p> <pre> Site : 03CH12-HY Condition : AVG_54 3m HORN_9120D_1328 VERTICAL Detector : RBW:1000.000kHz VBW:0.300kHz SWT:Auto Project : Peak Mode : 790120-02 Setting : 9 : 13 </pre>



2.4GHz 2400~2483.5MHz

WIFI 802.11n HT40 (Band Edge @ 3m)

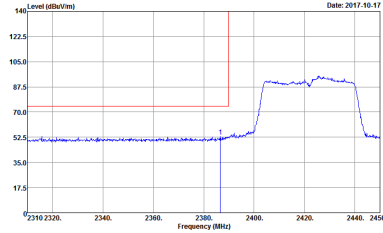
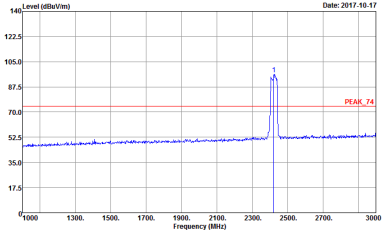
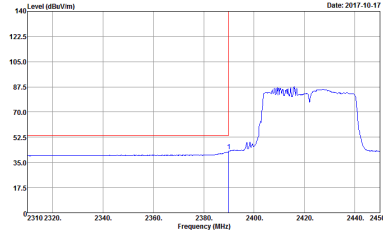
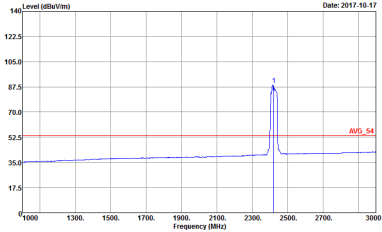
WIFI	2.4GHz 2400~2483.5MHz Band Edge @ 3m	
ANT	802.11n HT40 CH03 2422MHz - L	
1+2	Horizontal	Fundamental
Peak	 <p>Site : 03CH12-HY Condition : PEAK_BE_74 3m HORN_9120D_1328 HORIZONTAL REW:1000.000KHz VBW:3000.000KHz SWT:Auto Detector : Peak Project : 790120-02 Mode : 10 Setting : 11.5</p>	 <p>Site : 03CH12-HY Condition : PEAK_74 3m HORN_9120D_1328 HORIZONTAL REW:1000.000KHz VBW:3000.000KHz SWT:Auto Detector : Peak Project : 790120-02 Mode : 10 Setting : 11.5</p>
Avg.	 <p>Site : 03CH12-HY Condition : AVG_BE_54 3m HORN_9120D_1328 HORIZONTAL REW:1000.000KHz VBW:0.300KHz SWT:Auto Detector : Peak Project : 790120-02 Mode : 10 Setting : 11.5</p>	 <p>Site : 03CH12-HY Condition : AVG_54 3m HORN_9120D_1328 HORIZONTAL REW:1000.000KHz VBW:0.300KHz SWT:Auto Detector : Peak Project : 790120-02 Mode : 10 Setting : 11.5</p>

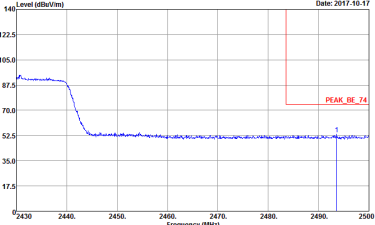
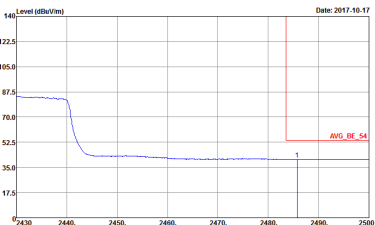

WIFI	2.4GHz 2400~2483.5MHz Band Edge @ 3m	
ANT	802.11n HT40 CH03 2422MHz - R	
1+2	Horizontal	Fundamental
<p>Peak</p>	 <p>Site : 03CH12-HY Condition : PEAK_BE_74 3m HORN_91200_1328 HORIZONTAL Detector : RBW:1000.000KHz VBW:3000.000KHz SWT:Auto Project : 790120-02 Mode : 10 Setting : 11.5</p>	<p>Left Blank</p>
<p>Avg.</p>	 <p>Site : 03CH12-HY Condition : AVG_BE_54 3m HORN_91200_1328 HORIZONTAL Detector : RBW:1000.000KHz VBW:0.300KHz SWT:Auto Project : 790120-02 Mode : 10 Setting : 11.5</p>	<p>Left Blank</p>

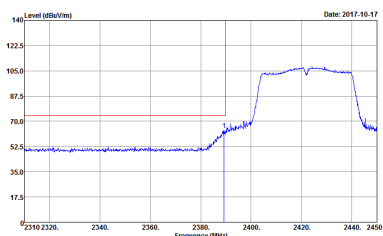
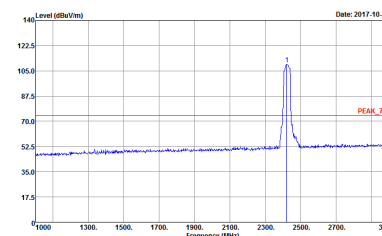
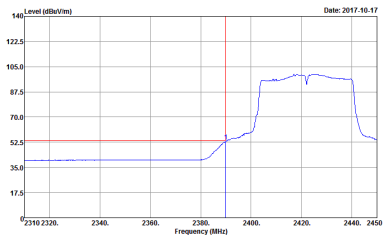
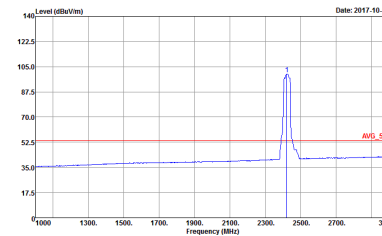

WIFI	2.4GHz 2400~2483.5MHz Band Edge @ 3m	
ANT	802.11n HT40 CH03 2422MHz - L	
1+2	Vertical	Fundamental
Peak	 <p>Site : 03CH12-HY Condition : PEAK_BE_74 3m HORN_9120D_1328 VERTICAL Detector : RBW:1000.000kHz VBW:3000.000kHz SWT:Auto Project : Peak Mode : 790120-02 Setting : -10</p>	 <p>Site : 03CH12-HY Condition : PEAK_74 3m HORN_9120D_1328 VERTICAL Detector : RBW:1000.000kHz VBW:3000.000kHz SWT:Auto Project : Peak Mode : 790120-02 Setting : -11.5</p>
Avg.	 <p>Site : 03CH12-HY Condition : AVG_BE_54 3m HORN_9120D_1328 VERTICAL Detector : RBW:1000.000kHz VBW:0.300kHz SWT:Auto Project : Peak Mode : 790120-02 Setting : -10</p>	 <p>Site : 03CH12-HY Condition : AVG_54 3m HORN_9120D_1328 VERTICAL Detector : Peak Project : 790120-02 Mode : 10 Setting : -11.5</p>



WIFI	2.4GHz 2400~2483.5MHz Band Edge @ 3m	
ANT	802.11n HT40 CH03 2422MHz - R	
1+2	Vertical	Fundamental
Peak	<p>Site : 03CH12-HY Condition : PEAK_BE_74 3m HORN_9120D_1338 VERTICAL Detector : RBW:1000.000KHz VBW:3000.000KHz SWT:Auto Project : 790120-02 Mode : 10 Setting : 11.5</p>	Left blank
Avg.	<p>Site : 03CH12-HY Condition : AVG_BE_54 3m HORN_9120D_1338 VERTICAL Detector : RBW:1000.000KHz VBW:0.300KHz SWT:Auto Project : 790120-02 Mode : 10 Setting : 11.5</p>	Left blank



2.4GHz 2400~2483.5MHz
 WIFI 802.11n HT20 (Harmonic @ 3m)

WIFI	2.4GHz 2400~2483.5MHz Harmonic @ 3m	
ANT	802.11n HT20 CH01 2412MHz	
1+2	Horizontal	Vertical
Peak Avg.	<p>Site : 03CH12-HY Condition : PEAK_74 3m HORN_9120D_1328 HORIZONTAL Detector : Peak Project : 790120-02 Mode : 9 Setting : 13</p>	<p>Site : 03CH12-HY Condition : PEAK_74 3m HORN_9120D_1328 VERTICAL Detector : Peak Project : 790120-02 Mode : 9 Setting : 13</p>



2.4GHz 2400~2483.5MHz
 WIFI 802.11n HT40 (Harmonic @ 3m)

WIFI	2.4GHz 2400~2483.5MHz Harmonic @ 3m	
ANT	802.11n HT40 CH03 2422MHz	
1+2	Horizontal	Vertical
Peak Avg.	<p>Site : 03CH12-HY Condition : PEAK_74 3m HORN_9120D_1328 HORIZONTAL Detector : Peak Project : 790120-02 Mode : 10 Setting : 11.5</p>	<p>Site : 03CH12-HY Condition : PEAK_74 3m HORN_9120D_1328 VERTICAL Detector : Peak Project : 790120-02 Mode : 10 Setting : 11.5</p>



Appendix C. Duty Cycle Plots

Antenna	Band	Duty Cycle(%)	T(us)	1/T(kHz)	VBW Setting
1	802.11b	100.00	-	-	10Hz
1+2	802.11b for Ant. 1	100.00	-	-	10Hz
1+2	802.11b for Ant. 2	100.00	-	-	10Hz
1	802.11g	95.28	726.00	1.38	3kHz
1+2	802.11g for Ant. 1	96.03	726.00	1.38	3kHz
1+2	802.11g for Ant. 2	95.28	726.00	1.38	3kHz
1	2.4GHz 802.11n HT20	95.83	690.00	1.45	3kHz
1+2	2.4GHz 802.11n HT20 for Ant. 1	95.04	690.00	1.45	3kHz
1+2	2.4GHz 802.11n HT20 for Ant. 2	95.83	690.00	1.45	3kHz
1	2.4GHz 802.11n HT40	94.74	648.00	1.54	3kHz
1+2	2.4GHz 802.11n HT40 for Ant. 1	95.58	645.00	1.557	3kHz
1+2	2.4GHz 802.11n HT40 for Ant. 2	95.58	648.00	1.54	3kHz



<Ant. 1>

802.11b

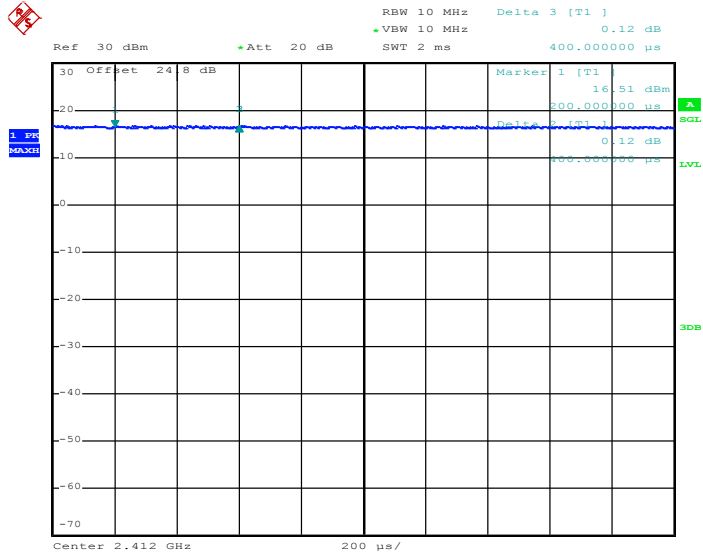

Date: 4.OCT.2017 16:07:21

802.11g

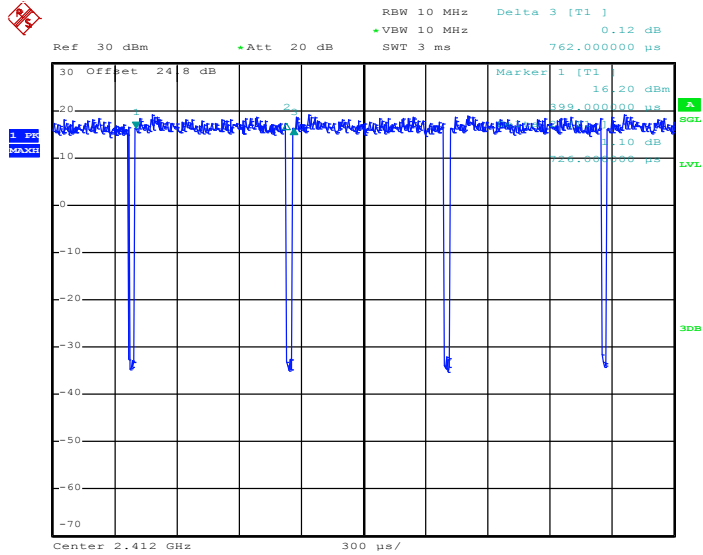

Date: 4.OCT.2017 17:01:07



802.11n HT20

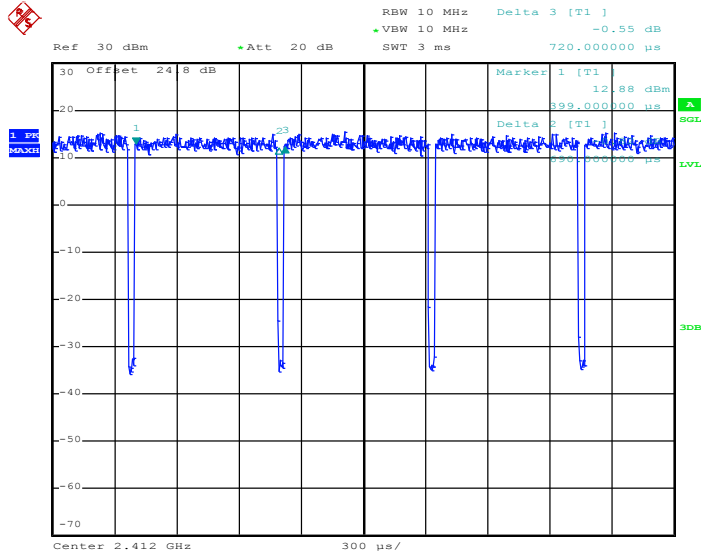

Date: 4.OCT.2017 17:40:41

802.11n HT40

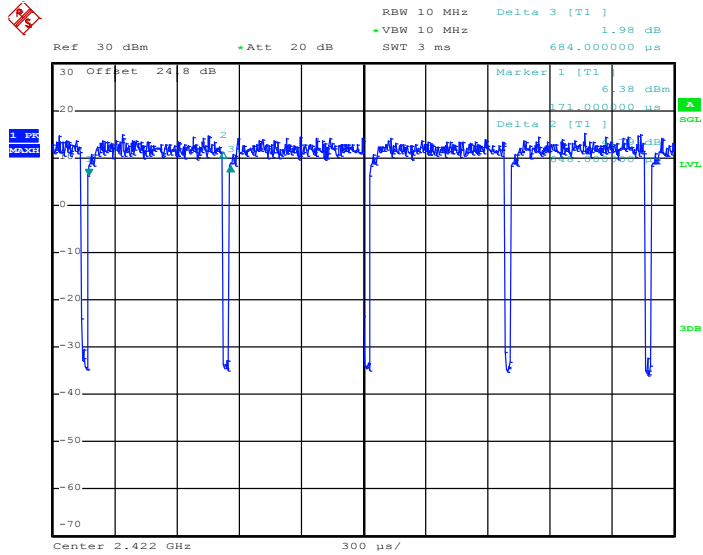

Date: 4.OCT.2017 18:31:03



<MIMO Ant. 1>

802.11b

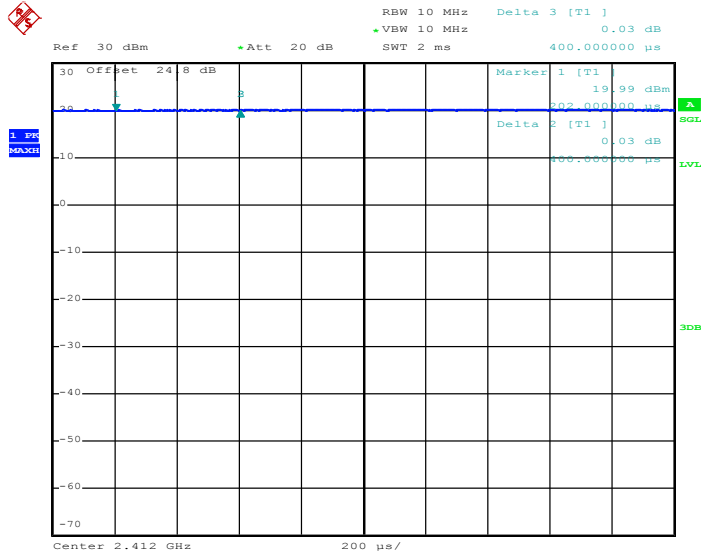

Date: 4.OCT.2017 16:36:07

802.11g

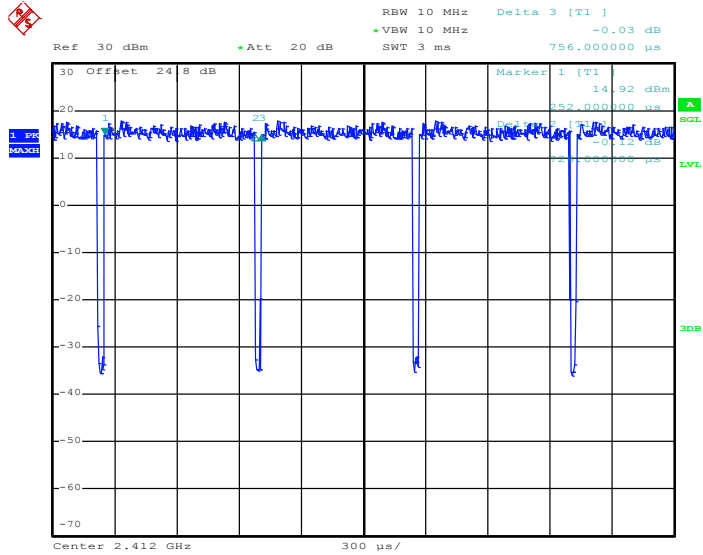

Date: 4.OCT.2017 17:21:18



802.11n HT20

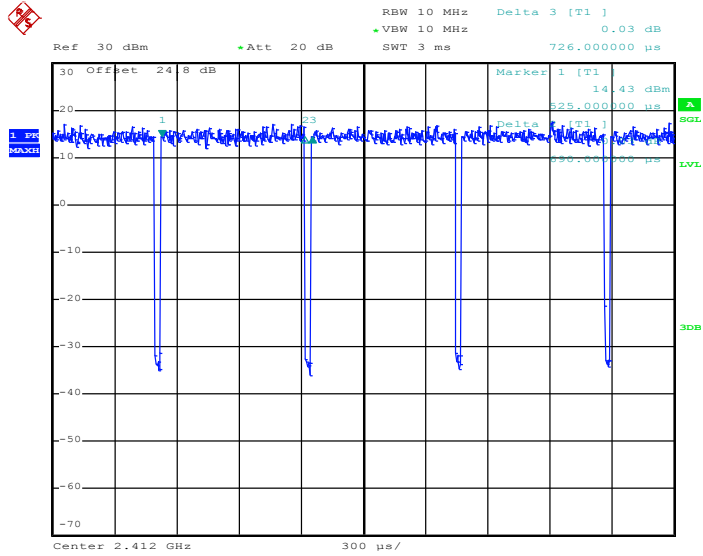

Date: 4.OCT.2017 18:16:35

802.11n HT40

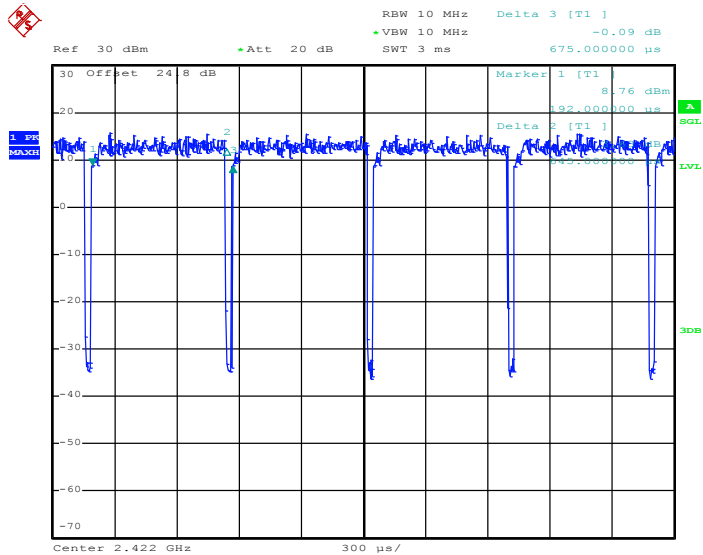

Date: 4.OCT.2017 18:47:31



<MIMO Ant. 2>

802.11b

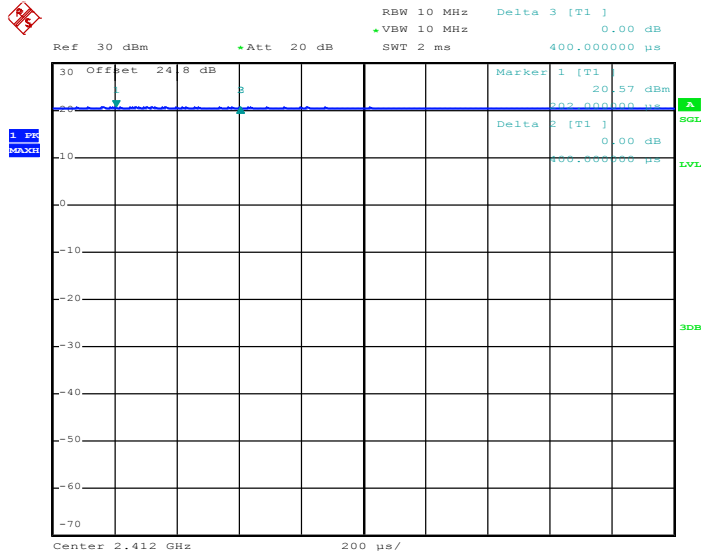

Date: 4.OCT.2017 16:36:43

802.11g

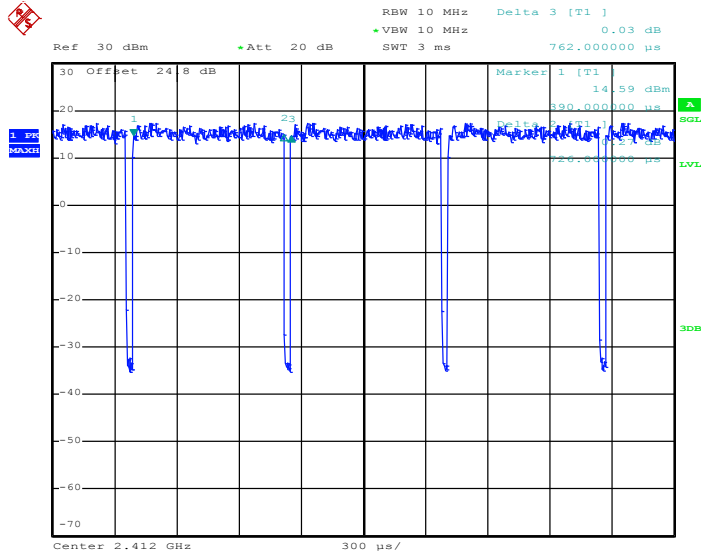

Date: 4.OCT.2017 17:22:05



802.11n HT20

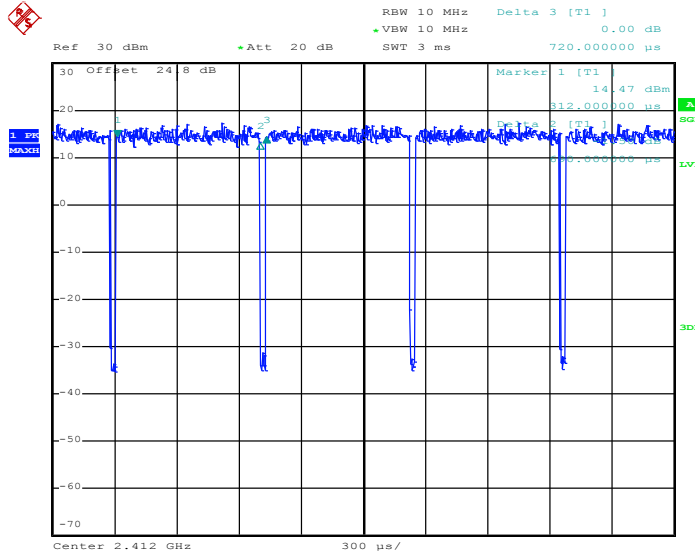

Date: 4.OCT.2017 18:17:25

802.11n HT40

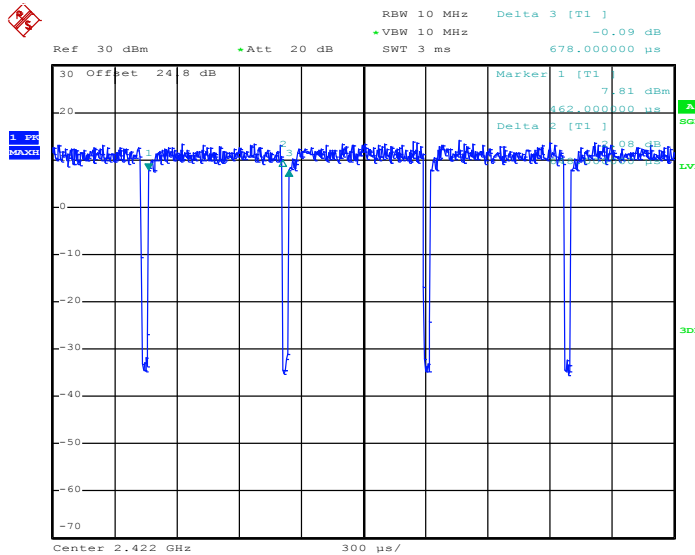

Date: 4.OCT.2017 18:48:19