



FCC TEST REPORT (RFID)

REPORT NO.: RF991201E03-4 R1

MODEL NO.: MC319ZUS

FCC ID: UZ7MC319ZUS

RECEIVED: Dec. 01, 2010

TESTED: Dec. 14, 2010 to Jan. 25, 2011

ISSUED: Mar. 17, 2011

APPLICANT: Motorola Solutions Inc.

ADDRESS: One Motorola Plaza Holts ville NY 11742-1300
USA

ISSUED BY: Bureau Veritas Consumer Products Services
(H.K.) Ltd., Taoyuan Branch Hsin Chu Laboratory

LAB ADDRESS: No. 81-1, Lu Liao Keng, 9th Ling,Wu Lung Tsuen,
Chiung Lin Hsiang, Hsin Chu Hsien 307, Taiwan

TEST LOCATION (1): No. 81-1, Lu Liao Keng, 9th Ling,Wu Lung Tsuen,
Chiung Lin Hsiang, Hsin Chu Hsien 307, Taiwan

TEST LOCATION (2): No.49, Ln. 206, Wende Rd., Shangshan Tsuen,
Chiung Lin Hsiang, Hsin Chu Hsien 307, Taiwan

This test report consists of 61 pages in total. It may be duplicated completely for legal use with the approval of the applicant. It should not be reproduced except in full, without the written approval of our laboratory. The client should not use it to claim product endorsement by TAF or any government agencies. The test results in the report only apply to the tested sample.





A D T

TABLE OF CONTENTS

RELEASE CONTROL RECORD	4
1 CERTIFICATION	5
2 SUMMARY OF TEST RESULTS.....	6
2.0 MEASUREMENT UNCERTAINTY	7
3 GENERAL INFORMATION	8
3.1 GENERAL DESCRIPTION OF EUT	8
3.2 DESCRIPTION OF TEST MODES	11
3.3 TEST MODE APPLICABILITY AND TESTED CHANNEL DETAIL:	12
3.4 GENERAL DESCRIPTION OF APPLIED STANDARDS	14
3.5 DESCRIPTION OF SUPPORT UNITS.....	15
3.6 CONFIGURATION OF SYSTEM UNDER TEST	16
4 TEST PROCEDURES AND RESULTS	18
4.1 CONDUCTED EMISSION MEASUREMENT	18
4.1.1 LIMITS OF CONDUCTED EMISSION MEASUREMENT	18
4.1.2 TEST INSTRUMENTS.....	18
4.1.3 TEST PROCEDURES	19
4.1.4 DEVIATION FROM TEST STANDARD	19
4.1.5 TEST SETUP	20
4.1.6 EUT OPERATING CONDITIONS.....	20
4.1.7 TEST RESULTS(MODE A)	21
4.1.8 TEST RESULTS(MODE B)	23
4.2 NUMBER OF HOPPING FREQUENCY USED	25
4.2.1 LIMIT OF HOPPING FREQUENCY USED	25
4.2.2 TEST INSTRUMENTS.....	25
4.2.3 TEST PROCEDURES	26
4.2.4 DEVIATION FROM TEST STANDARD	26
4.2.5 TEST SETUP	27
4.2.6 TEST RESULTS	27
4.3 DWELL TIME ON EACH CHANNEL.....	29
4.3.1 LIMIT OF DWELL TIME USED	29
4.3.2 TEST INSTRUMENTS.....	29
4.3.3 TEST PROCEDURES	30
4.3.4 DEVIATION FROM TEST STANDARD	30
4.3.5 TEST SETUP	30
4.3.6 TEST RESULTS	31
4.4 CHANNEL BANDWIDTH.....	33
4.4.1 LIMIT OF CHANNEL BANDWIDTH	33
4.4.2 TEST INSTRUMENTS.....	33
4.4.3 TEST PROCEDURE.....	34
4.4.4 DEVIATION FROM TEST STANDARD	34
4.4.5 TEST SETUP	34
4.4.6 EUT OPERATING CONDITION.....	34



A D T

4.4.7	TEST RESULTS	35
4.5	HOPPING CHANNEL SEPARATION	36
4.5.1	LIMIT OF HOPPING CHANNEL SEPARATION	36
4.5.2	TEST INSTRUMENTS	36
4.5.3	TEST PROCEDURES	37
4.5.4	DEVIATION FROM TEST STANDARD	37
4.5.5	TEST SETUP	37
4.5.6	TEST RESULTS	38
4.6	MAXIMUM PEAK OUTPUT POWER	41
4.6.1	LIMITS OF MAXIMUM PEAK OUTPUT POWER MEASUREMENT	41
4.6.2	INSTRUMENTS	41
4.6.3	TEST PROCEDURES	42
4.6.4	DEVIATION FROM TEST STANDARD	42
4.6.5	TEST SETUP	43
4.6.6	EUT OPERATING CONDITION	43
4.6.7	TEST RESULTS	44
4.7	RADIATED EMISSION MEASUREMENT	45
4.7.1	LIMITS OF RADIATED EMISSION MEASUREMENT	45
4.7.2	TEST INSTRUMENTS	46
4.7.3	TEST PROCEDURES	48
4.7.4	DEVIATION FROM TEST STANDARD	48
4.7.5	TEST SETUP	49
4.7.6	TEST RESULTS	50
4.8	CONDUCTED OUT-BAND EMISSION MEASUREMENT	56
4.8.1	LIMITS OF CONDUCTED OUT-BAND EMISSION MEASUREMENT	56
4.8.2	TEST INSTRUMENTS	56
4.8.3	TEST PROCEDURE	56
4.8.4	DEVIATION FROM TEST STANDARD	56
4.8.5	EUT OPERATING CONDITION	56
4.8.6	TEST RESULTS	57
5	INFORMATION ON THE TESTING LABORATORIES	60
6	APPENDIX A - MODIFICATIONS RECORDERS FOR ENGINEERING CHANGES TO THE EUT BY THE LAB	61



A D T

RELEASE CONTROL RECORD

ISSUE NO.	REASON FOR CHANGE	DATE ISSUED
Original release	NA	Mar. 09, 2011
RF991201E03-4 R1	Modify the test plot on page 32.	Mar. 17, 2011



A D T

1 CERTIFICATION

PRODUCT : Mobile Computing Terminal
BRAND NAME : MOTOROLA
MODEL NO. : MC319ZUS
APPLICANT : Motorola Solutions Inc.
TESTED DATE: Dec. 14, 2010 to Jan. 25, 2011
TEST SAMPLE : ENGINEERING SAMPLE
STANDARDS : 47 CFR Part 15, Subpart C (Section 15.247),
ANSI C63.4-2003
ANSI C63.10-2009

The above equipment (Model: MC319ZUS) has been tested by **Bureau Veritas Consumer Products Services (H.K.) Ltd., Taoyuan Branch**, and found compliance with the requirement of the above standards. The test record, data evaluation & Equipment Under Test (EUT) configurations represented herein are true and accurate accounts of the measurements of the sample's EMC characteristics under the conditions specified in this report.

PREPARED BY :  , **DATE:** Mar. 17, 2011
(Claire Kuan, Specialist)

APPROVED BY :  , **DATE:** Mar. 17, 2011
(May Chen, Deputy Manager)



A D T

2 SUMMARY OF TEST RESULTS

The EUT has been tested according to the following specifications:

APPLIED STANDARD: 47 CFR Part 15, Subpart C			
Standard Section	Test Type and Limit	Result	REMARK
15.207	AC Power Conducted Emission	PASS	Meet the requirement of limit Minimum passing margin is -14.07dB at 0.150 MHz
15.247(a)(1)(i)	Number of Hopping Frequency Used Spec.:	PASS	Meet the requirement of limit
15.247(a)(1)(i)	Dwell Time on Each Channel Spec.: Max. 0.4 second	PASS	Meet the requirement of limit
15.247(a)(1)	Hopping Channel Separation Spec.: Min. 25 kHz or 20 dB bandwidth, which ever is greater	PASS	Meet the requirement of limit
15.247(a)(1)(i)	Spectrum Bandwidth of a Frequency Hopping Sequence Spread Spectrum System	PASS	Meet the requirement of limit
15.247(b)(2)	Maximum Peak Output Power Spec.: max. 30dBm	PASS	Meet the requirement of limit
15.247(d)	Transmitter Radiated Emissions Spec.: Table 15.209	PASS	Meet the requirement of limit Minimum passing margin is -5.6dB at 896.74MHz
15.247(d)	Conducted Out-Band Emission Measurement	PASS	Meet the requirement of limit
15.203	Antenna Requirement	PASS	Antenna connector is Hirose connector.

2.0 MEASUREMENT UNCERTAINTY

Where relevant, the following measurement uncertainty levels have been estimated for tests performed on the EUT as specified in CISPR 16-4-2:

This uncertainty represents an expanded uncertainty expressed at approximately the 95% confidence level using a coverage factor of $k=2$.

Measurement	Value
Conducted emissions	2.45 dB
Radiated emissions (30MHz-1GHz)	3.30 dB
Radiated emissions (1GHz ~18GHz)	2.19 dB
Radiated emissions (18GHz ~40GHz)	2.55 dB

3 GENERAL INFORMATION

3.1 GENERAL DESCRIPTION OF EUT

PRODUCT	Mobile Computing Terminal
MODEL NO.	MC319ZUS
FCC ID	UZ7MC319ZUS
POWER SUPPLY	DC 3.7V from battery, DC 12V to cradle or DC 5.4V to cable adapter
MODULATION TYPE	PR-ASK(DRM), PSD-ASK(MRM), PR-ASK(XRM)
MODULATION TECHNOLOGY	FHSS
FREQUENCY RANGE	902.75MHz ~ 927.25MHz
NUMBER OF CHANNEL	50
OUTPUT POWER	955.0mW
ANTENNA TYPE	Please see note 2
DATA CABLE	Charger cable(Unshielded, 1.8m with one core) x 1 RS232 cable(Unshielded, 1.8m)x 1 USB cable(Shielded, 1.55m) x 1
I/O PORTS	micro SD port x 1
ASSOCIATED DEVICES	Battery x 1 (Part No.: 82-127909-02 Rev B)

NOTE:

- There are Bluetooth technology (BT2.1+EDR), WLAN and RFID technology used for the EUT:

Technology	Report No.
DFS	RF991201E03
15.247	RF991201E03-1
15.407	RF991201E03-2
Bluetooth	RF991201E03-3
RFID	RF991201E03-4



A D T

2. There are antennas provided to this EUT, please refer to the following table:

WLAN Antenna Spec.								
NO.	Brand	Antenna Type	Peak Gain(dBi) with cable loss	Connecter Type	Frequency range (MHz)	Cable Loss (dB)	Cable Length	
1	Auden	Monopole + coupling	3.4 dBi (2.4GHz) 4.5 dBi (5GHz)	hirose	2.4 ~ 2.5 GHz 4.92 ~ 5.85 GHz	-0.2640 dB -0.6168 dB	52 mm	
2	Auden	PIFA	1.3 dBi (2.4GHz) 3.6 dBi (5GHz)	hirose	2.4 ~ 2.5 GHz 4.92 ~ 5.85 GHz	-0.6409 dB -1.0418 dB	68 mm	
RFID Antenna Spec.								
NO.	Brand	Antenna Type	Peak Gain(dBi) with cable loss	Connecter Type	Frequency range (MHz)	Cable Loss (dB)	Cable Length	
1	Auden	Dipole	3.66	hirose	902 ~ 928 MHz	-0.43 dB	85 mm	
2	Auden	Slot Dipole	1.95	hirose	902 ~ 928 MHz	-0.43 dB	85 mm	
Bluetooth Antenna Spec.								
NO.	Brand	Model No.	Antenna Type	Peak Gain(dBi)	Connecter Type	Frequency range (MHz)	Cable Loss (dB)	Cable Length
1	Antenova	(Mica 2.4GHz) 303DA5654-01	Chip Antenna	-1.34	U.FL	2400-2500	0.185	74 mm

3. The EUT could be supplied with a Cradle, power adapter and battery as below table:

Battery	
Brand:	MOTOROLA
Part No.:	82-127909-02 Rev B
Rating:	3.7V, 4800mAh/17.8Wh
Cable adapter (not for sale together)	
Brand:	MOTOROLA
Model No.:	EADP-16BB A
Part No.:	PWRS-14000-249R
Input power :	100-240V, 50-60Hz, 0.4A AC input cable (unshielded, 1.85m)
Output power :	5.4V ----- 3A
Cradle (not for sale together)	
Brand:	SYMBOL TECHNOLOGIES INC.
Model No.:	CRD3000-1000R
Part No.:	CRD3000-1001RR
Rating:	12V, 3.33A
Adapter for Cradle (not for sale together)	
Brand:	HIPRO
Model No.:	HP-O204D43
Part No.:	50-14000-148R
Input power :	100-240V, 50-60Hz, 1.5A AC input cable (unshielded, 1.8m)
Output power :	+12V ----- 3.33A DC output cable (unshielded, 1.8m with one core)

4. The EUT was pre-tested in chamber under following test modes :

Pre-test Mode	Description
Mode A	X-Y plane: EUT + Battery
Mode B	X-Z plane: EUT + Battery
Mode C	Y-Z plane: EUT + Battery
Mode D	X-Y plane: EUT + Cable adapter
Mode E	X-Z plane: EUT + Cable adapter
Mode F	Y-Z plane: EUT + Cable adapter
Mode G	Y-Z plane: EUT + Cradle + adapter

The worse radiated emission was found in **Mode E**. Therefore only the test data of the modes were recorded in this report.

5. The EUT operates in both the 5GHz and 2.4GHz Bands and compatibility with 802.11a, 802.11b, 802.11g, Bluetooth technology and RFID in the 900MHz Band.



A D T

- The above EUT information was declared by the manufacturer and for more detailed feature descriptions, please refer to the manufacturer's specifications or User's Manual.

3.2 DESCRIPTION OF TEST MODES

Fifty channels are provided to this EUT.

Channel	Freq. (MHz)	Channel	Freq. (MHz)	Channel	Freq. (MHz)
0	902.75	21	913.25	42	923.75
1	903.25	22	913.75	43	924.25
2	903.75	23	914.25	44	924.75
3	904.25	24	914.75	45	925.25
4	904.75	25	915.25	46	925.75
5	905.25	26	915.75	47	926.25
6	905.75	27	916.25	48	926.75
7	906.25	28	916.75	49	927.25
8	906.75	29	917.25		
9	907.25	30	917.75		
10	907.75	31	918.25		
11	908.25	32	918.75		
12	908.75	33	919.25		
13	909.25	34	919.75		
14	909.75	35	920.25		
15	910.25	36	920.75		
16	910.75	37	921.25		
17	911.25	38	921.75		
18	911.75	39	922.25		
19	912.25	40	922.75		
20	912.75	41	923.25		

3.3 TEST MODE APPLICABILITY AND TESTED CHANNEL DETAIL:

EUT configure mode	Applicable to				Description
	PLC	RE<1G	RE [≥] 1G	APCM	
A	-	√	√	√	X-Z plane: EUT + Cable adapter
B	√	-	-	-	X-Y plane: EUT + Cable adapter
C	√	-	-	-	Y-Z plane: EUT + Cradle + adapter

Where PLC: Power Line Conducted Emission
RE[≥]1G: Radiated Emission above 1GHz

RE<1G RE: Radiated Emission below 1GHz
APCM: Antenna Port Conducted Measurement

Power Line Conducted Emission:

- Pre-Scan to determine the worst-case mode from all possible combinations between available modulations and packet types.
- Following channel(s) was (were) selected for the final test as listed below.

Available Channel	Tested Channel	Modulation Technology	Modulation Type	EUT configure mode
0 to 49	0	FHSS	PR-ASK(XRM)	B
0 to 49	0	FHSS	PR-ASK(XRM)	C

Radiated Emission Test (Below 1 GHz):

- Pre-Scan has been conducted to determine the worst-case mode from all possible combinations between available modulations, data rates and antenna ports (if EUT with antenna diversity architecture).
- Following channel(s) was (were) selected for the final test as listed below.

Available Channel	Tested Channel	Modulation Technology	Modulation Type	EUT configure mode
0 to 49	0, 24, 49	FHSS	PR-ASK(XRM)	A

Radiated Emission Test (Above 1 GHz):

- Pre-Scan has been conducted to determine the worst-case mode from all possible combinations between available modulations, data rates and antenna ports (if EUT with antenna diversity architecture).
- Following channel(s) was (were) selected for the final test as listed below.

Available Channel	Tested Channel	Modulation Technology	Modulation Type	EUT configure mode
0 to 49	0, 24, 49	FHSS	PR-ASK(XRM)	A



A D T

Conducted Out-Band Emission Measurement:

Pre-Scan has been conducted to determine the worst-case mode from all possible combinations between available modulations, data rates and antenna ports (if EUT with antenna diversity architecture).

Following channel(s) was (were) selected for the final test as listed below.

Available Channel	Tested Channel	Modulation Technology	Modulation Type	EUT configure mode
0 to 49	0, 49	FHSS	PR-ASK(XRM)	A

Antenna Port Conducted Measurement:

Pre-Scan has been conducted to determine the worst-case mode from all possible combinations between available modulations, data rates and antenna ports (if EUT with antenna diversity architecture).

Following channel(s) was (were) selected for the final test as listed below.

Available Channel	Tested Channel	Modulation Technology	Modulation Type	EUT configure mode
0 to 49	0, 24, 49	FHSS	PR-ASK(XRM)	A

※ **TEST CONDITION:**

APPLICABLE TO	ENVIRONMENTAL CONDITIONS	INPUT POWER (SYSTEM)	TESTED BY
RE ³ 1G	18deg. C, 70%RH, 1021 hPa	120Vac, 60Hz	Eric Lee
RE<1G	19deg. C, 64%RH, 1021 hPa	120Vac, 60Hz	Frank Liu
PLC	25deg. C, 60%RH, 1021 hPa	120Vac, 60Hz	Max Tseng
APCM	20deg. C, 60%RH, 1021 hPa	120Vac, 60Hz	Eric Lee



A D T

3.4 GENERAL DESCRIPTION OF APPLIED STANDARDS

The EUT is a RF product. According to the specifications of the manufacturer, it must comply with the requirements of the following standards:

FCC Part 15, Subpart C. (15.247)

ANSI C63.4-2003

ANSI C63.10-2009

All test items have been performed and recorded as per the above standards.

NOTE: The EUT has been verified to comply with the requirements of FCC Part 15, Subpart B, Class B (DoC). The test report has been issued separately.



3.5 DESCRIPTION OF SUPPORT UNITS

The EUT has been tested as an independent unit together with other necessary accessories or support units. The following support units or accessories were used to form a representative test configuration during the tests.

For conducted test					
No.	Product	Brand	Model No.	Serial No.	FCC ID
1	PERSONAL COMPUTER	DELL	DCSCMF	9KKB32S	FCC DoC
2	MONITOR	DELL	E2210Hc	CN-OG337R-6418 0-97S-OQDS	FCC DoC
3	PRINTER	EPSON	LQ-300+II	G88Y074083	FCC DoC
4	MODEM	ACEEX	1414	0206026778	IFAXDM1414
5	KEYBOARD	DELL	SK-8115	MY-0DJ325-71619- 99B-0476	FCC DoC
6	MOUSE	DELL	MOC5UO	I1401LVG	FCC DoC
7	EARPHONE	Hawk	HKC920	H001	FCC DoC
For other test item					
No.	Product	Brand	Model No.	Serial No.	FCC ID
1	NOTEBOOK COMPUTER	DELL	PP32LA	DSL32S	FCC DoC
2	EARPHONE	MOTOROLA	NA	NA	NA

For conducted test	
No.	Signal cable description
1	NA
2	1.8 m braid shielded wire, terminated with VGA connector via metallic frame, with two cores
3	1.8m braid shielded wire, terminated with DB25 and Centronics connector via metallic frame, w/o core
4	1.2 m braid shielded wire, terminated with DB25 and DB9 connector via metallic frame, w/o core.
5	1.9 m foil shielded wire, USB connector, w/o core.
6	1.8 m foil shielded wire, USB connector, w/o core.
7	1.8 m Audio cable
For other test item	
No.	Signal cable description
1	NA
2	0.9 m Audio cable

NOTE: All power cords of the above support units are non shielded (1.8m).

3.6 CONFIGURATION OF SYSTEM UNDER TEST

For Conducted test mode 1:

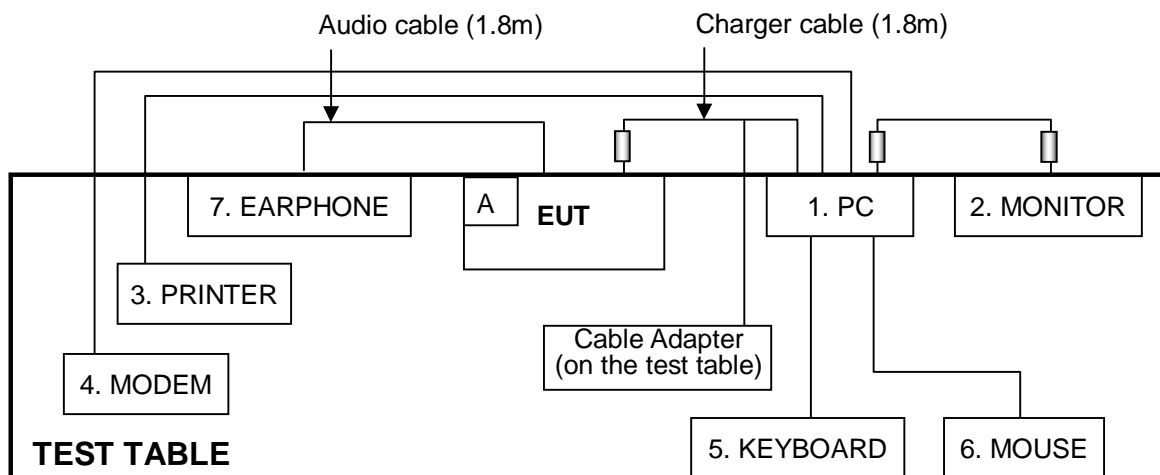

NOTE: 1. Item A is the micro SD card.

For Conducted test mode 2:

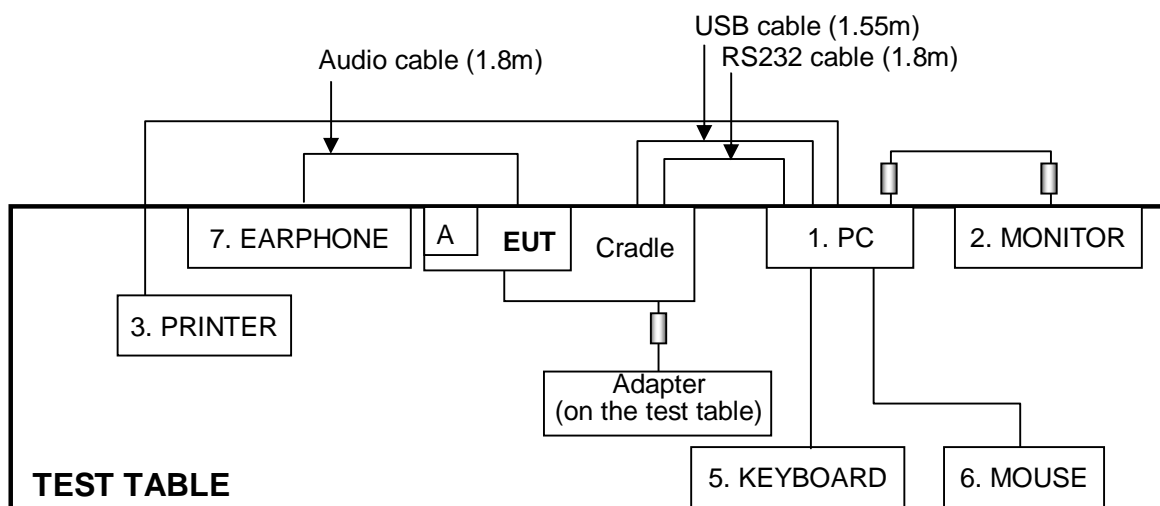

NOTE: 1. Item A is the micro SD Card.

Other test items:

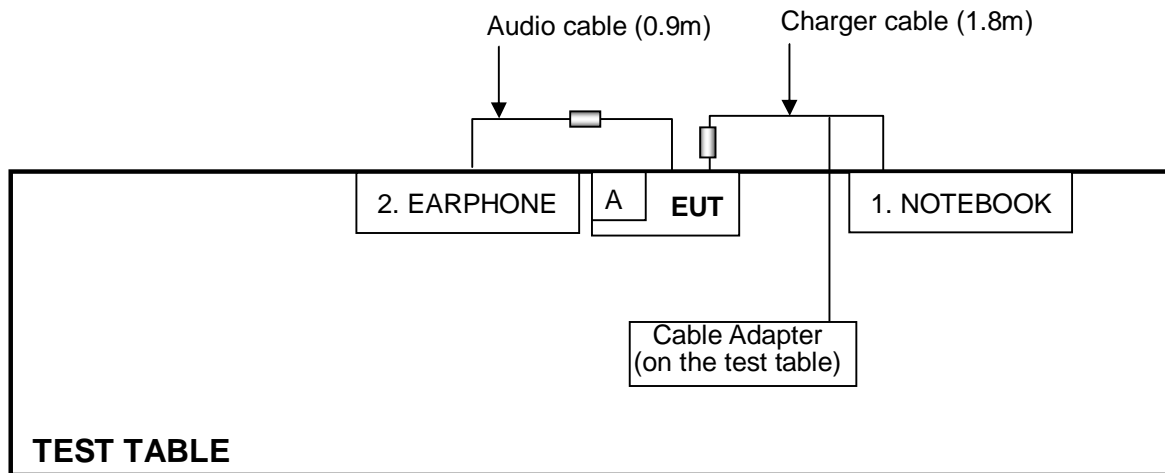

NOTE: 1. Item A is the micro SD Card.



A D T

4 TEST PROCEDURES AND RESULTS

4.1 CONDUCTED EMISSION MEASUREMENT

4.1.1 LIMITS OF CONDUCTED EMISSION MEASUREMENT

FREQUENCY OF EMISSION (MHz)	CONDUCTED LIMIT (dB μ V)	
	Quasi-peak	Average
0.15-0.5	66 to 56	56 to 46
0.5-5	56	46
5-30	60	50

Notes:

1. The lower limit shall apply at the transition frequencies.
2. All emanations from a class A/B digital device or system, including any network of conductors and apparatus connected thereto, shall not exceed the level of field strengths specified above.

4.1.2 TEST INSTRUMENTS

DESCRIPTION & MANUFACTURER	MODEL NO.	SERIAL NO.	CALIBRATED DATE	CALIBRATED UNTIL
Test Receiver	ESCS 30	100375	Mar. 09, 2010	Mar. 08, 2011
Line-Impedance Stabilization Network (for EUT)	NSLK 8127	8127-522	Sep. 08, 2010	Sep. 07, 2011
Line-Impedance Stabilization Network (for Peripheral)	ESH3-Z5	848773/004	Nov. 03, 2010	Nov. 02, 2011
RF Cable (JYEBAO)	5DFB	COCCAB-002	Aug. 30, 2010	Aug. 29, 2011
50 ohms Terminator	50	3	Nov. 03, 2010	Nov. 02, 2011
Software	BV ADT_Cond_V7.3.7	NA	NA	NA

Note:

1. The calibration interval of the above test instruments is 12 months and the calibrations are traceable to NML/ROC and NIST/USA.
2. The test was performed in Shielded Room No. C.
3. The VCCI Con C Registration No. is C-3611.



A D T

4.1.3 TEST PROCEDURES

- a. The EUT was placed 0.4 meters from the conducting wall of the shielded room with EUT being connected to the power mains through a line impedance stabilization network (LISN). Other support units were connected to the power mains through another LISN. The two LISNs provide 50 ohm/ 50uH of coupling impedance for the measuring instrument.
- b. Both lines of the power mains connected to the EUT were checked for maximum conducted interference.
- c. The frequency range from 150kHz to 30MHz was searched. Emission levels under Limit - 20dB was not recorded.

4.1.4 DEVIATION FROM TEST STANDARD

No deviation

4.1.5 TEST SETUP

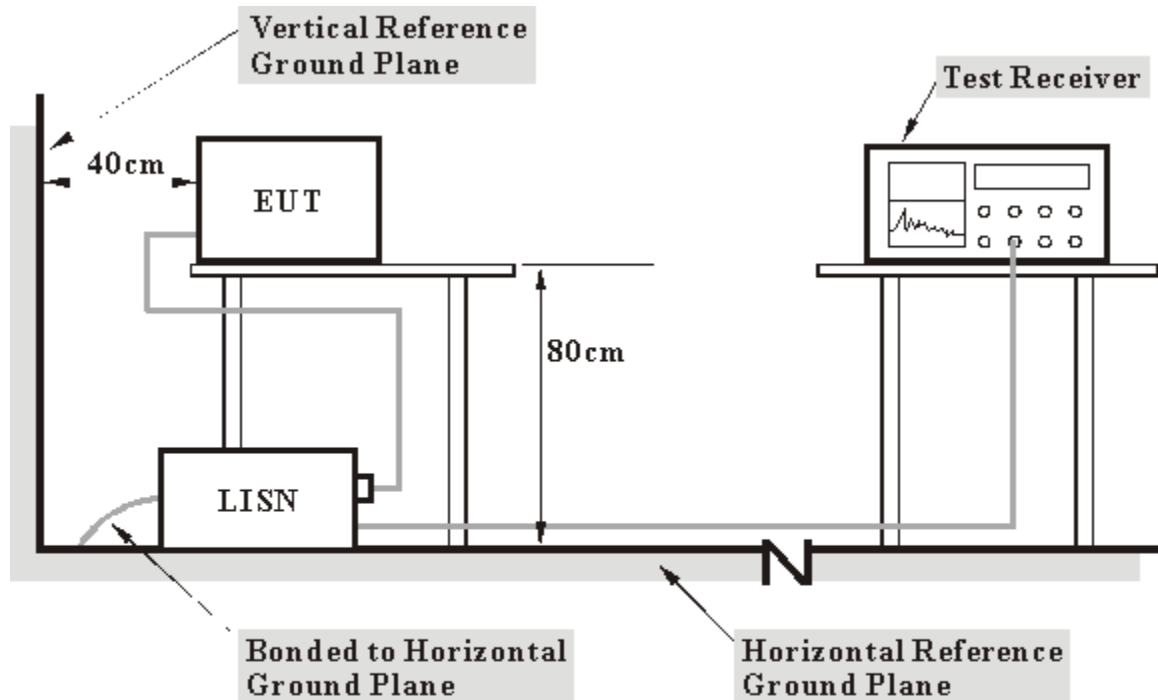

- Note:**
1. Support units were connected to second LISN.
 2. Both of LISNs (AMN) 80 cm from EUT and at the least 80 cm from other units and other metal planes support units.

For the actual test configuration, please refer to the related item – Photographs of the Test Configuration.

4.1.6 EUT OPERATING CONDITIONS

- a. Turn on the power of EUT.
- b. The EUT run test program “RFIDRegulator Test.exe” to enable EUT under transmission / receiver condition continuously at specific channel frequency.

4.1.7 TEST RESULTS(MODE A)

PHASE	Line (L)	6dB BANDWIDTH	9 kHz
--------------	----------	----------------------	-------

No	Freq. [MHz]	Corr. Factor (dB)	Reading Value		Emission Level		Limit		Margin	
			[dB (uV)]		[dB (uV)]		[dB (uV)]		(dB)	
			Q.P.	AV.	Q.P.	AV.	Q.P.	AV.	Q.P.	AV.
1	0.150	0.10	51.83	-	51.93	-	66.00	56.00	-14.07	-
2	0.173	0.12	48.23	-	48.35	-	64.79	54.79	-16.45	-
3	0.205	0.13	45.42	-	45.55	-	63.42	53.42	-17.87	-
4	0.466	0.13	37.44	-	37.57	-	56.58	46.58	-19.01	-
5	5.762	0.28	30.41	-	30.69	-	60.00	50.00	-29.31	-
6	15.277	0.57	38.82	-	39.39	-	60.00	50.00	-20.61	-

- REMARKS:**
1. Q.P. and AV. are abbreviations of quasi-peak and average individually.
 2. "-": The Quasi-peak reading value also meets average limit and measurement with the average detector is unnecessary.
 3. The emission levels of other frequencies were very low against the limit.
 4. Margin value = Emission level - Limit value
 5. Correction factor = Insertion loss + Cable loss
 6. Emission Level = Correction Factor + Reading Value.

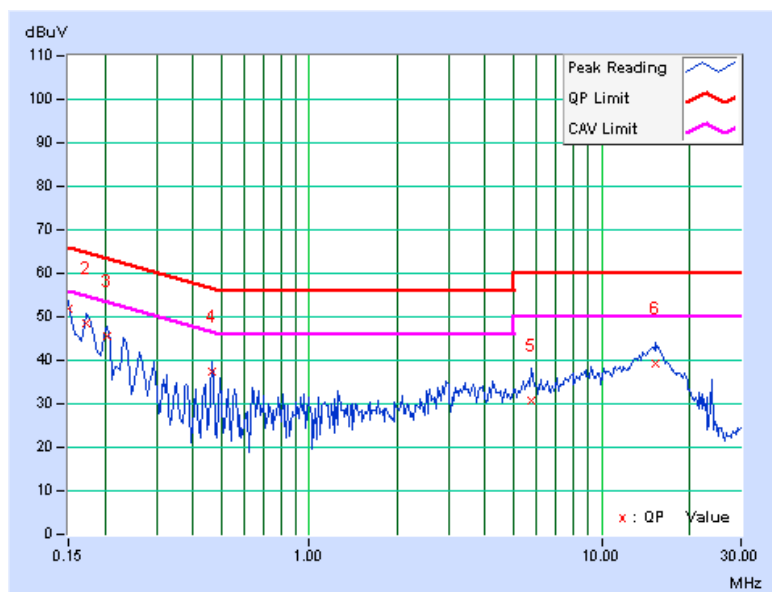

PHASE	Neutral (N)	6dB BANDWIDTH	9 kHz
--------------	-------------	----------------------	-------

No	Freq. [MHz]	Corr. Factor (dB)	Reading Value		Emission Level		Limit		Margin	
			[dB (uV)]		[dB (uV)]		[dB (uV)]		(dB)	
			Q.P.	AV.	Q.P.	AV.	Q.P.	AV.	Q.P.	AV.
1	0.150	0.12	51.16	-	51.28	-	66.00	56.00	-14.72	-
2	0.177	0.13	48.29	-	48.42	-	64.61	54.61	-16.19	-
3	0.205	0.14	45.40	-	45.54	-	63.42	53.42	-17.88	-
4	0.466	0.15	38.24	-	38.39	-	56.58	46.58	-18.19	-
5	3.855	0.27	30.74	-	31.01	-	56.00	46.00	-24.99	-
6	15.090	1.13	39.18	-	40.31	-	60.00	50.00	-19.69	-

- REMARKS:**
1. Q.P. and AV. are abbreviations of quasi-peak and average individually.
 2. "-": The Quasi-peak reading value also meets average limit and measurement with the average detector is unnecessary.
 3. The emission levels of other frequencies were very low against the limit.
 4. Margin value = Emission level - Limit value
 5. Correction factor = Insertion loss + Cable loss
 6. Emission Level = Correction Factor + Reading Value.

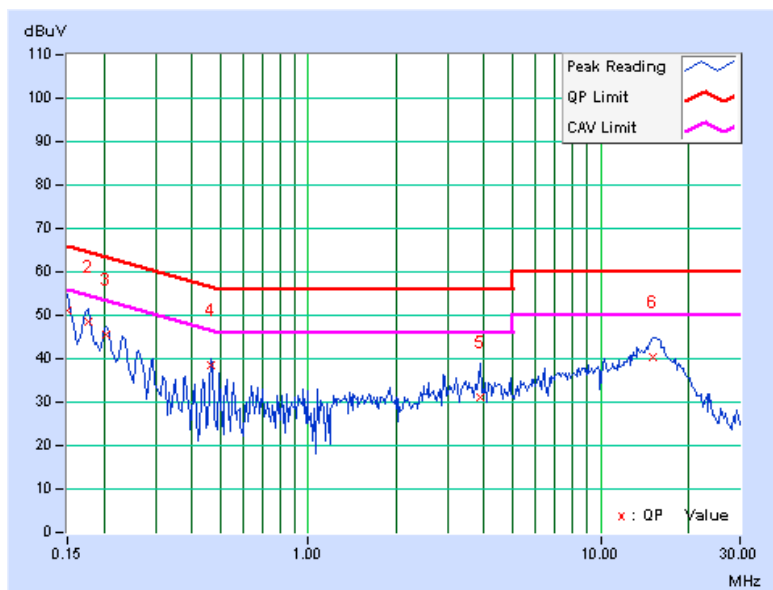

4.1.8 TEST RESULTS(MODE B)

PHASE	Line (L)	6dB BANDWIDTH	9 kHz
--------------	----------	----------------------	-------

No	Freq. [MHz]	Corr. Factor (dB)	Reading Value		Emission Level		Limit		Margin	
			[dB (uV)]		[dB (uV)]		[dB (uV)]		(dB)	
			Q.P.	AV.	Q.P.	AV.	Q.P.	AV.	Q.P.	AV.
1	0.209	0.13	44.47	-	44.60	-	63.26	53.26	-18.66	-
2	0.630	0.13	34.13	-	34.26	-	56.00	46.00	-21.74	-
3	0.736	0.14	35.41	-	35.55	-	56.00	46.00	-20.45	-
4	2.734	0.17	35.74	-	35.91	-	56.00	46.00	-20.09	-
5	3.047	0.18	37.45	-	37.63	-	56.00	46.00	-18.37	-
6	22.797	0.75	39.12	-	39.87	-	60.00	50.00	-20.13	-

- REMARKS:**
1. Q.P. and AV. are abbreviations of quasi-peak and average individually.
 2. "-": The Quasi-peak reading value also meets average limit and measurement with the average detector is unnecessary.
 3. The emission levels of other frequencies were very low against the limit.
 4. Margin value = Emission level - Limit value
 5. Correction factor = Insertion loss + Cable loss
 6. Emission Level = Correction Factor + Reading Value.

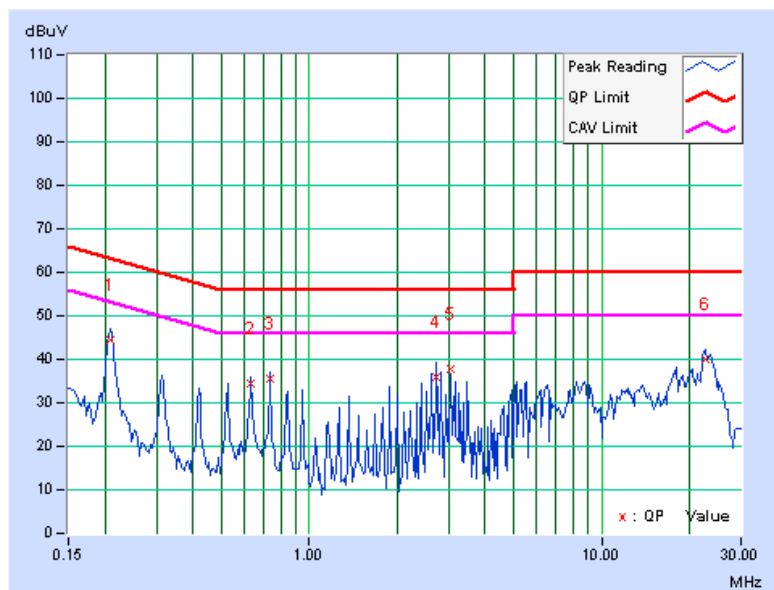

PHASE	Neutral (N)	6dB BANDWIDTH	9 kHz
--------------	-------------	----------------------	-------

No	Freq. [MHz]	Corr. Factor (dB)	Reading Value		Emission Level		Limit		Margin	
			[dB (uV)]		[dB (uV)]		[dB (uV)]		(dB)	
			Q.P.	AV.	Q.P.	AV.	Q.P.	AV.	Q.P.	AV.
1	0.209	0.14	43.47	-	43.61	-	63.26	53.26	-19.65	-
2	0.314	0.15	34.07	-	34.22	-	59.86	49.86	-25.65	-
3	0.736	0.16	36.88	-	37.04	-	56.00	46.00	-18.96	-
4	2.941	0.23	39.05	-	39.28	-	56.00	46.00	-16.72	-
5	3.258	0.25	36.38	-	36.63	-	56.00	46.00	-19.37	-
6	23.531	1.69	36.61	-	38.30	-	60.00	50.00	-21.70	-

- REMARKS:**
1. Q.P. and AV. are abbreviations of quasi-peak and average individually.
 2. "-": The Quasi-peak reading value also meets average limit and measurement with the average detector is unnecessary.
 3. The emission levels of other frequencies were very low against the limit.
 4. Margin value = Emission level - Limit value
 5. Correction factor = Insertion loss + Cable loss
 6. Emission Level = Correction Factor + Reading Value.

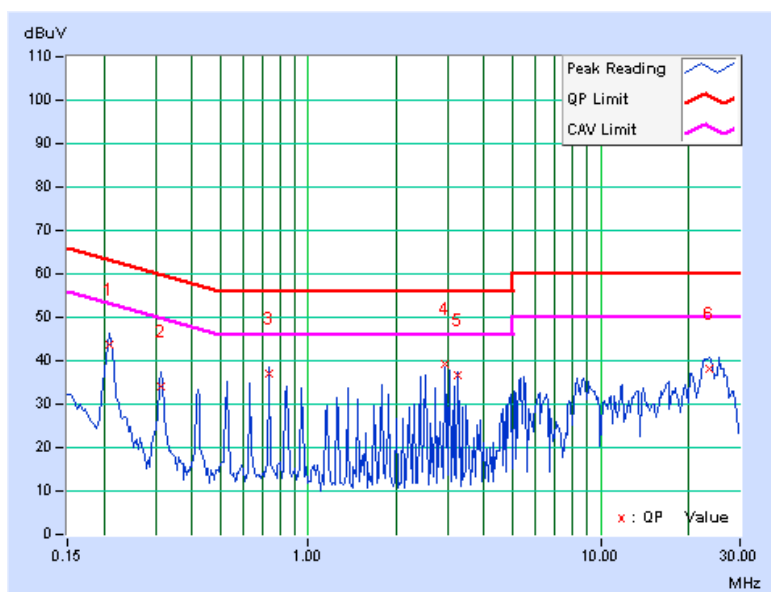



A D T

4.2 NUMBER OF HOPPING FREQUENCY USED

4.2.1 LIMIT OF HOPPING FREQUENCY USED

At least 50 hopping frequencies, and should be equally spaced.

4.2.2 TEST INSTRUMENTS

DESCRIPTION & MANUFACTURER	MODEL NO.	SERIAL NO.	CALIBRATED DATE	CALIBRATED UNTIL
Spectrum Analyzer	E4446A	MY482502 54	July 14, 2010	July 13, 2011

NOTE:

1. The calibration interval of the above test instruments is 12 months and the calibrations are traceable to NML/ROC and NIST/USA.

4.2.3 TEST PROCEDURES

1. Check the calibration of the measuring instrument (SA) using either an internal calibrator or a known signal from an external generator.
2. Turn on the EUT and connect its antenna terminal to measurement via a low loss cable. Then set it to any one measured frequency within its operating range and make sure the instrument is operated in its linear range.
3. Set the SA on MaxHold Mode, and then keep the EUT in hopping mode. Record all the signals from each channel until each one has been recorded.
4. Set the SA on View mode and then plot the result on SA screen.
5. Repeat above procedures until all frequencies measured were complete.

4.2.4 DEVIATION FROM TEST STANDARD

No deviation

4.2.5 TEST SETUP

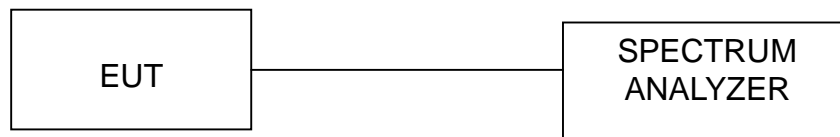

4.2.6 TEST RESULTS

There are 50 hopping frequencies in the hopping mode. Please refer to next two pages for the test result. On the plots, it shows that the hopping frequencies are equally spaced.



A D T

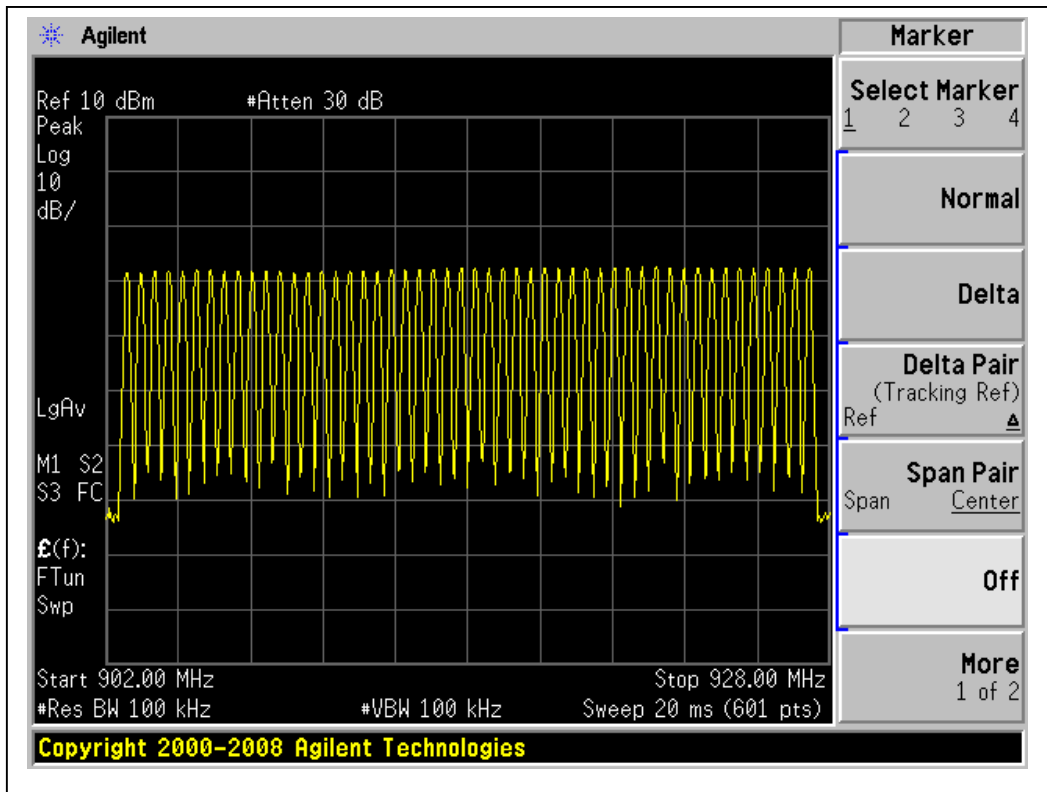



4.3 DWELL TIME ON EACH CHANNEL

4.3.1 LIMIT OF DWELL TIME USED

For FHSS, the average time of occupancy on any frequency shall not be greater than 0.4 seconds within a 20 second period. For hybrid systems, the average time of occupancy on any frequency should not exceed 0.4 seconds within a time period in seconds equal to the number of hopping frequencies employed multiplied by 0.4.

4.3.2 TEST INSTRUMENTS

DESCRIPTION & MANUFACTURER	MODEL NO.	SERIAL NO.	CALIBRATED DATE	CALIBRATED UNTIL
Spectrum Analyzer	E4446A	MY482502 54	July 14, 2010	July 13, 2011

NOTE:

- 1.The calibration interval of the above test instruments is 12 months and the calibrations are traceable to NML/ROC and NIST/USA.

4.3.3 TEST PROCEDURES

1. Check the calibration of the measuring instrument (SA) using either an internal calibrator or a known signal from an external generator.
2. Turn on the EUT and connect its antenna terminal to measurement via a low loss cable. Then set it to any one measured frequency within its operating range and make sure the instrument is operated in its linear range.
3. Adjust the center frequency of SA on any frequency be measured and set SA to zero span mode. And then, set RBW and VBW of spectrum analyzer to proper value.
4. Measure the time duration of one transmission on the measured frequency. And then plot the result with time difference of this time duration.
5. Repeat above procedures until all frequencies measured were complete.

4.3.4 DEVIATION FROM TEST STANDARD

No deviation

4.3.5 TEST SETUP





A D T

4.3.6 TEST RESULTS

Number of transmission in a 20 s	Length of transmission time (msec)	Result (msec)	Limit (msec)
8 times	27	216	400

Test plots of the transmitting time slot are shown on next page.



A D T

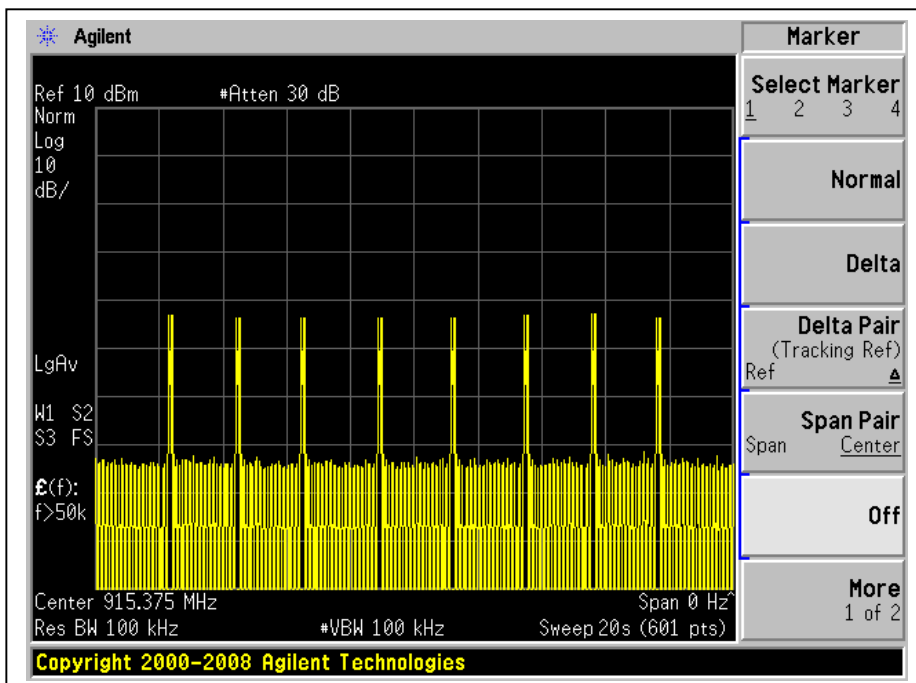
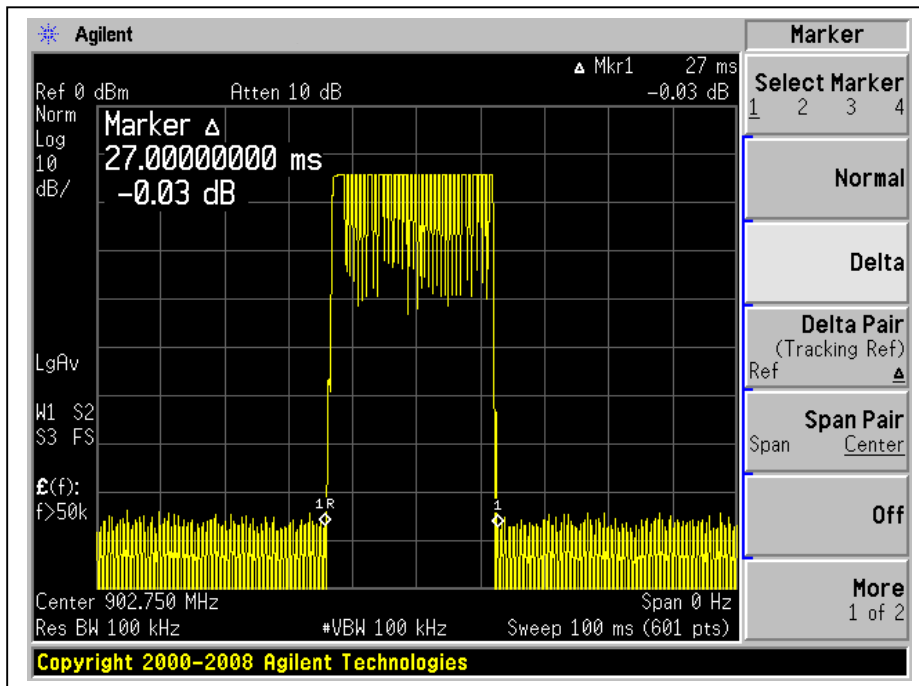



A D T

4.4 CHANNEL BANDWIDTH

4.4.1 LIMIT OF CHANNEL BANDWIDTH

The -20 dB bandwidth of the hopping channel must less than 250 kHz

4.4.2 TEST INSTRUMENTS

DESCRIPTION & MANUFACTURER	MODEL NO.	SERIAL NO.	CALIBRATED DATE	CALIBRATED UNTIL
R&S SPECTRUM ANALYZER	FSP40	100037	Sep. 08, 2010	Sep. 07, 2011

NOTE:

- 1.The calibration interval of the above test instruments is 12 months and the calibrations are traceable to NML/ROC and NIST/USA.

4.4.3 TEST PROCEDURE

1. Check the calibration of the measuring instrument using either an internal calibrator or a known signal from an external generator.
2. Turn on the EUT and connect it to measurement instrument. Then set it to any one convenient frequency within its operating range. Set a reference level on the measuring instrument equal to the highest peak value.
3. Measure the frequency difference of two frequencies that were attenuated 20dB from the reference level. Record the frequency difference as the emission bandwidth.
4. Repeat above procedures until all frequencies measured were complete.

4.4.4 DEVIATION FROM TEST STANDARD

No deviation

4.4.5 TEST SETUP



4.4.6 EUT OPERATING CONDITION

The software provided by client enabled the EUT to transmit and receive data at lowest, middle and highest channel frequencies individually.



A D T

4.4.7 TEST RESULTS

CHANNEL	CHANNEL FREQUENCY (MHz)	20dB BANDWIDTH (kHz)
0	902.75	126
24	914.75	131
49	927.25	130

Channel 24

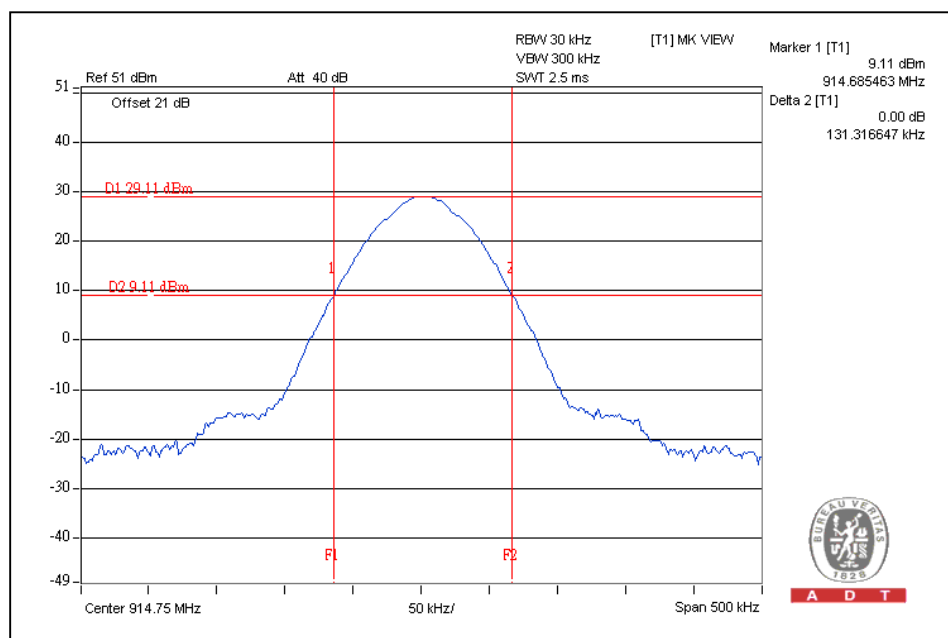



4.5 HOPPING CHANNEL SEPARATION

4.5.1 LIMIT OF HOPPING CHANNEL SEPARATION

At least 25 kHz or 20dB hopping channel bandwidth (whichever is greater).

4.5.2 TEST INSTRUMENTS

DESCRIPTION & MANUFACTURER	MODEL NO.	SERIAL NO.	CALIBRATED DATE	CALIBRATED UNTIL
R&S SPECTRUM ANALYZER	FSP40	100037	Sep. 08, 2010	Sep. 07, 2011

NOTE:

1. The calibration interval of the above test instruments is 12 months and the calibrations are traceable to NML/ROC and NIST/USA.

4.5.3 TEST PROCEDURES

1. Check the calibration of the measuring instrument using either an internal calibrator or a known signal from an external generator.
2. Turn on the EUT and connect it to measurement instrument. Then set it to any one convenient frequency within its operating range.
3. By using the MaxHold function record the separation of two adjacent channels.
4. Measure the frequency difference of these two adjacent channels by SA MARK function. And then plot the result on SA screen.
5. Repeat above procedures until all frequencies measured were complete.

4.5.4 DEVIATION FROM TEST STANDARD

No deviation

4.5.5 TEST SETUP

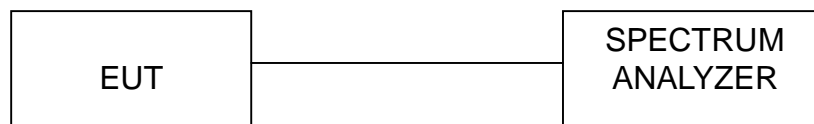

4.5.6 TEST RESULTS

Channel	Frequency (MHz)	Adjacent Channel Separation	Minimum Limit (kHz)	Pass / Fail
0	902.75	505kHz	126	PASS
24	914.75	503kHz	131	PASS
49	927.25	507kHz	130	PASS

The minimum limit is 20dB bandwidth. Test results please refer to next two pages.



A D T

Channel 0

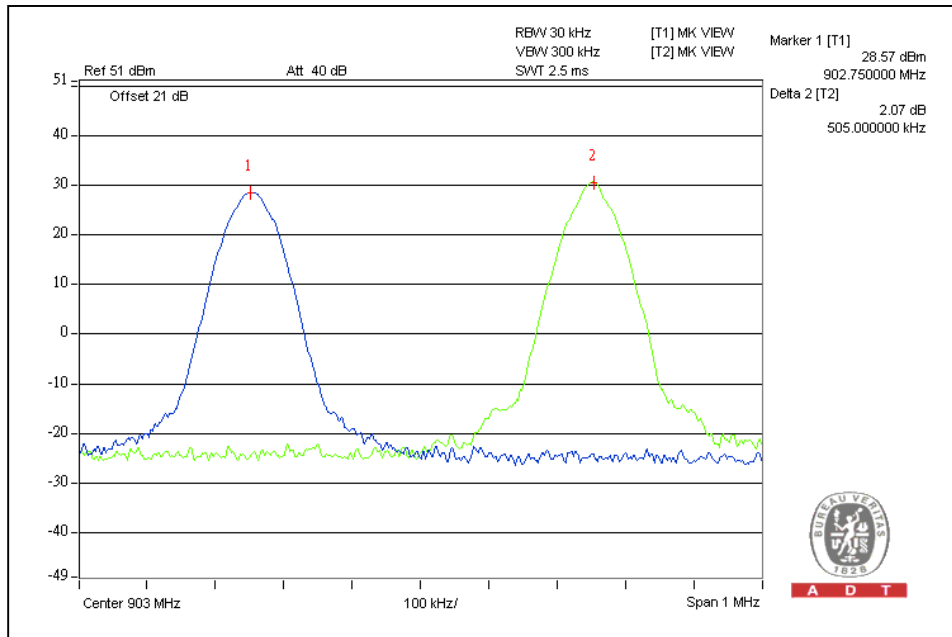

Channel 25

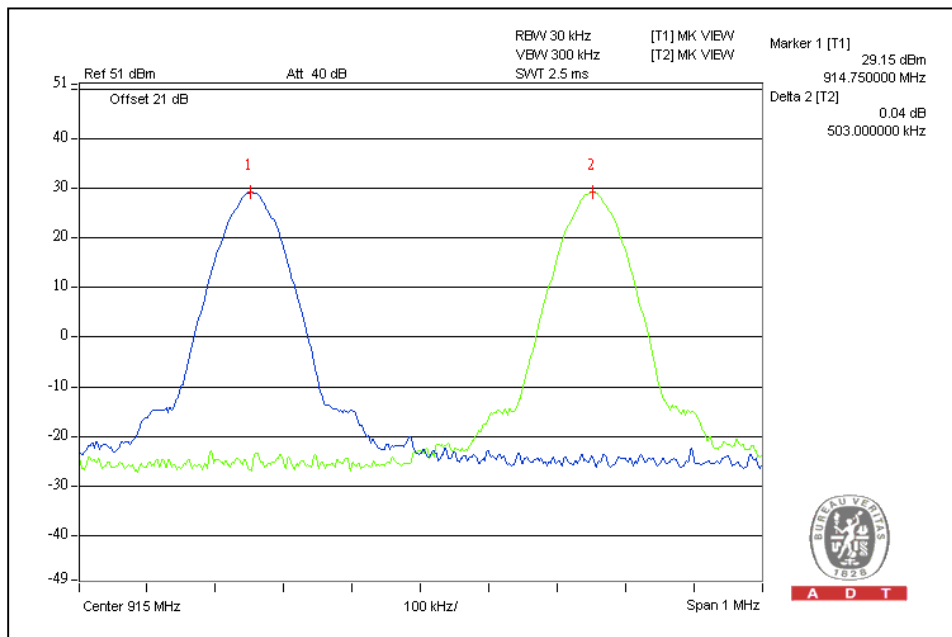



A D T

Channel 49

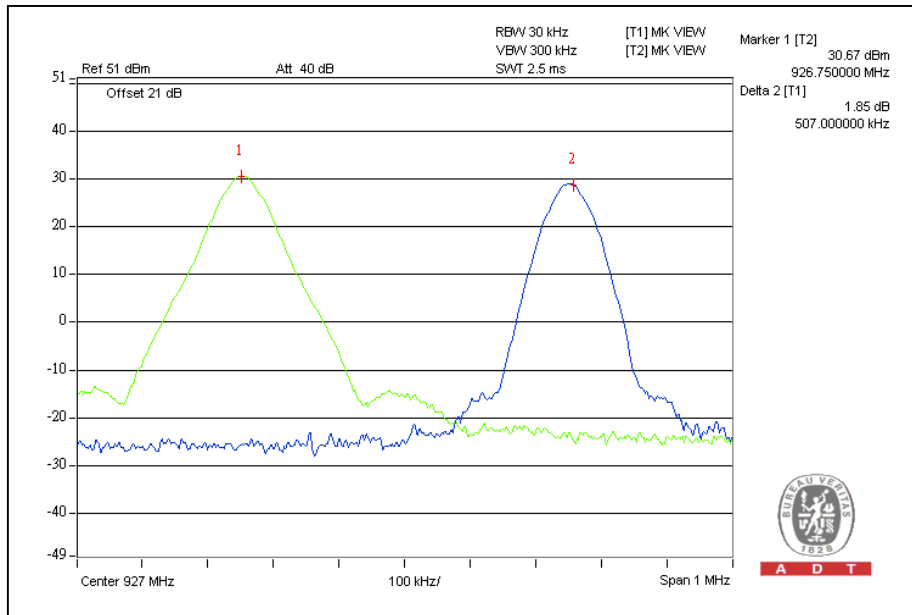

A D T



4.6 MAXIMUM PEAK OUTPUT POWER

4.6.1 LIMITS OF MAXIMUM PEAK OUTPUT POWER MEASUREMENT

The Maximum Peak Output Power Measurement is 30dBm.

4.6.2 INSTRUMENTS

DESCRIPTION & MANUFACTURER	MODEL NO.	SERIAL NO.	CALIBRATED DATE	CALIBRATED UNTIL
R&S SPECTRUM ANALYZER	FSP40	100037	Sep. 08, 2010	Sep. 07, 2011

NOTE:

- 1.The calibration interval of the above test instruments is 12 months and the calibrations are traceable to NML/ROC and NIST/USA.

4.6.3 TEST PROCEDURES

- a. Check the calibration of the measuring instrument using either an internal calibrator or a known signal from an external generator.
- b. Turn on the EUT and connect it to measurement instrument. Then set it to any one convenient frequency within its operating range. Set a reference level on the measuring instrument equal to the highest peak value.
- c. The center frequency of the spectrum analyzer is set to the fundamental frequency and using 3MHz RBW and 10 MHz VBW.
- d. Measure the captured power within the band and recording the plot.
- e. Repeat above procedures until all frequencies required were complete.

4.6.4 DEVIATION FROM TEST STANDARD

No deviation

4.6.5 TEST SETUP

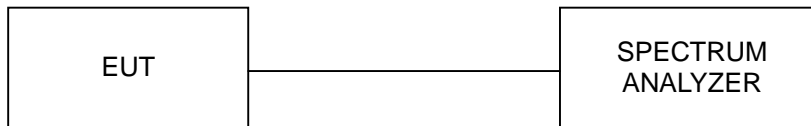

For the actual test configuration, please refer to the related Item – Photographs of the Test Configuration.

4.6.6 EUT OPERATING CONDITION

The software provided by client enabled the EUT to transmit and receive data at lowest, middle and highest channel frequencies individually.



A D T

4.6.7 TEST RESULTS

CHANNEL	CHANNEL FREQUENCY (MHz)	PEAK POWER OUTPUT (mW)	PEAK POWER OUTPUT (dBm)	PEAK POWER LIMIT (dBm)	PASS/FAIL
0	902.75	955.0	29.8	30	PASS
24	914.75	891.3	29.5	30	PASS
49	927.25	871.0	29.4	30	PASS

Channel 0

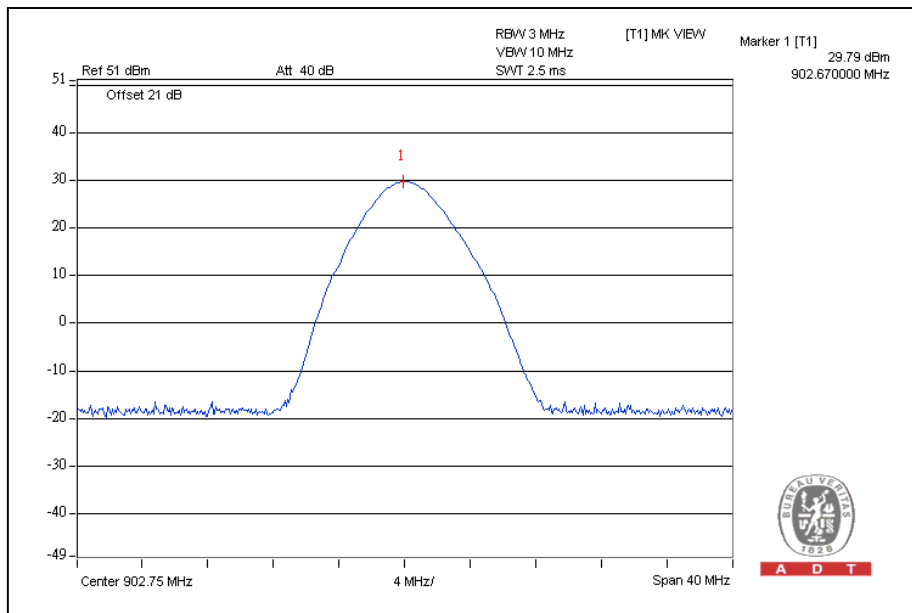

4.7 RADIATED EMISSION MEASUREMENT

4.7.1 LIMITS OF RADIATED EMISSION MEASUREMENT

Emissions radiated outside of the specified bands, shall be according to the general radiated limits in 15.209 as following:

Frequencies (MHz)	Field strength (microvolts/meter)	Measurement distance (meters)
0.009-0.490	2400/F(kHz)	300
0.490-1.705	24000/F(kHz)	30
1.705-30.0	30	30
30-88	100	3
88-216	150	3
216-960	200	3
Above 960	500	3

As shown in 15.35(b), for frequencies above 1000MHz, the field strength limits are based on average detector, however, the peak field strength of any emission shall not exceed the maximum permitted average limits, specified above by more than 20dB under any condition of modulation.



A D T

4.7.2 TEST INSTRUMENTS

For below 1GHz test:

DESCRIPTION & MANUFACTURER	MODEL NO.	SERIAL NO.	CALIBRATED DATE	CALIBRATED UNTIL
Agilent Spectrum Analyzer	E4446A	MY48250254	July 14, 2010	July 13, 2011
Agilent Pre-Selector	N9039A	MY46520311	July 14, 2010	July 13, 2011
Agilent Signal Generator	N5181A	MY49060517	July 14, 2010	July 13, 2011
Mini-Circuits Pre-Amplifier	ZFL-1000VH2B	AMP-ZFL-03	Nov. 16, 2010	Nov. 15, 2011
Agilent Pre-Amplifier	8449B	3008A02578	July 05, 2010	July 04, 2011
Miteq Pre-Amplifier	AFS33-1800265 0-30-8P-44	881786	NA	NA
SCHWARZBECK Trilog Broadband Antenna	VULB 9168	9168-360	Apr. 29, 2010	Apr. 28, 2011
AISI Horn_Antenna	AIH.8018	0000320091110	Nov. 12, 2010	Nov. 11, 2011
SCHWARZBECK Horn_Antenna	BBHA 9170	9170-424	Oct. 08, 2010	Oct. 07, 2011
RF CABLE	NA	RF104-201 RF104-203 RF104-204	Dec. 27, 2010	Dec. 26, 2011
RF Cable	NA	CHGCAB_001	NA	NA
Software	ADT_Radiated_V8.7.05	NA	NA	NA
CT Antenna Tower & Turn Table	NA	NA	NA	NA

Note: 1. The calibration interval of the above test instruments is 12 months and the calibrations are traceable to NML/ROC and NIST/USA.

2. The horn antenna, preamplifier (model: 8449B) are used only for the measurement of emission frequency above 1GHz if tested.

3. The test was performed in 966 Chamber No. G.

4. The FCC Site Registration No. is 966073.

5. The VCCI Site Registration No. is G-137.

6. The CANADA Site Registration No. is IC 7450H-2.



A D T

For above 1GHz test:

DESCRIPTION & MANUFACTURER	MODEL NO.	SERIAL NO.	CALIBRATED DATE	CALIBRATED UNTIL
Agilent Spectrum Analyzer	E4446A	MY48250253	Aug. 23, 2010	Aug. 22, 2011
Agilent Pre-Selector	N9039A	MY46520310	Aug. 23, 2010	Aug. 22, 2011
Agilent Signal Generator	N5181A	MY49060347	July 30, 2010	July 29, 2011
LIG NEX1 Test Receiver	ER-265	L09068005	Oct. 25, 2010	Oct. 24, 2011
Mini-Circuits Pre-Amplifier	ZFL-1000VH2B	AMP-ZFL-04	Nov. 16, 2010	Nov. 15, 2011
Agilent Pre-Amplifier	8449B	3008A02465	Mar. 01, 2010	Feb. 28, 2011
Miteq Pre-Amplifier	AFS33-1800265 0-30-8P-44	881786	NA	NA
SCHWARZBECK Trilog Broadband Antenna	VULB 9168	9168-361	Apr. 28, 2010	Apr. 27, 2011
AISI Horn_Antenna	AIH.8018	0000220091110	Nov. 22, 2010	Nov. 21, 2011
SCHWARZBECK Horn_Antenna	BBHA 9170	9170-424	Oct. 08, 2010	Oct. 07, 2011
RF CABLE	NA	RF104-205 RF104-207 RF104-202	Dec. 28, 2010	Dec. 27, 2011
RF Cable	NA	CHHCAB_001	NA	NA
Software	ADT_Radiated_V8.7.05	NA	NA	NA
CT Antenna Tower & Turn Table	NA	NA	NA	NA

- Note: 1. The calibration interval of the above test instruments is 12 months and the calibrations are traceable to NML/ROC and NIST/USA.
2. The horn antenna, preamplifier (model: 8449B) are used only for the measurement of emission frequency above 1GHz if tested.
3. The test was performed in 966 Chamber No. H.
4. The FCC Site Registration No. is 797305.
5. The CANADA Site Registration No. is IC 7450H-3.

4.7.3 TEST PROCEDURES

- a. The EUT was placed on the top of a rotating table 0.8 meters above the ground at a 3 meter chamber room. The table was rotated 360 degrees to determine the position of the highest radiation.
- b. The EUT was set 3 meters away from the interference-receiving antenna, which was mounted on the top of a variable-height antenna tower.
- c. The antenna is a broadband antenna, and its height is varied from one meter to four meters above the ground to determine the maximum value of the field strength. Both horizontal and vertical polarizations of the antenna are set to make the measurement.
- d. For each suspected emission, the EUT was arranged to its worst case and then the antenna was tuned to heights from 1 meter to 4 meters and the rotatable table was turned from 0 degrees to 360 degrees to find the maximum reading.
- e. The test-receiver system was set to Peak Detect Function and Specified Bandwidth with Maximum Hold Mode.
- f. If the emission level of the EUT in peak mode was 10 dB lower than the limit specified, then testing could be stopped and the peak values of the EUT would be reported. Otherwise the emissions that did not have 10 dB margin would be re-tested one by one using peak, quasi-peak or average method as specified and then reported in a data sheet.

NOTE:

1. The resolution bandwidth and video bandwidth of test receiver/spectrum analyzer is 120kHz for Peak detection (PK) and Quasi-peak detection (QP) at frequency below 1GHz.
2. The resolution bandwidth is 1MHz and video bandwidth of test receiver/spectrum analyzer is 3MHz for Peak detection at frequency above 1GHz.

4.7.4 DEVIATION FROM TEST STANDARD

No deviation

4.7.5 TEST SETUP

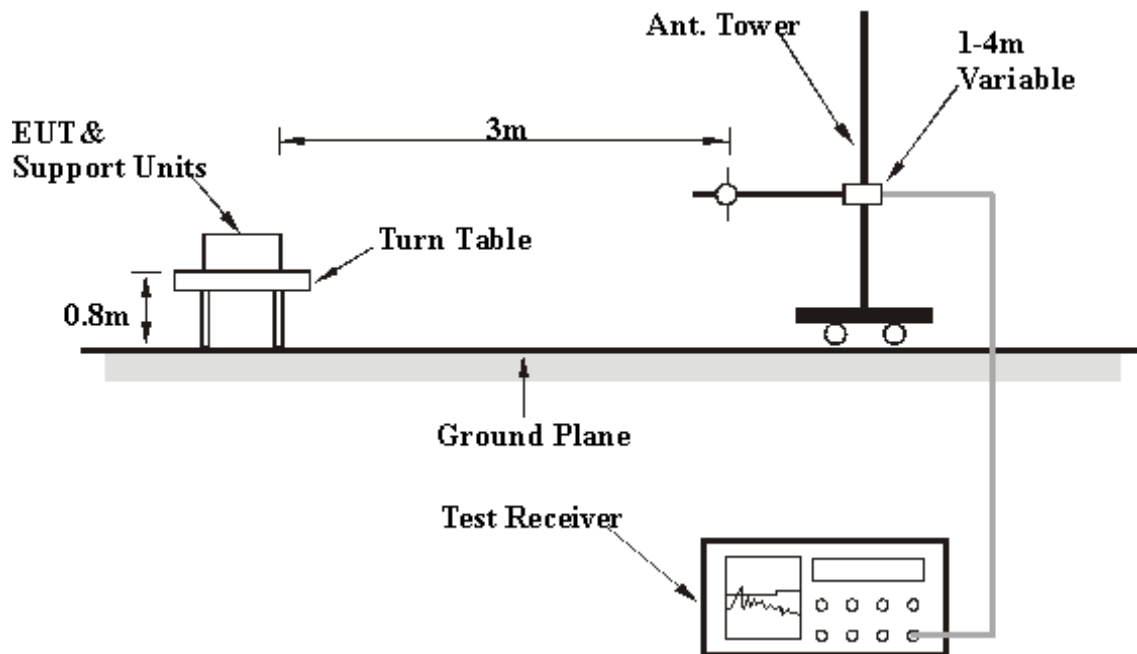

For the actual test configuration, please refer to the related item – Photographs of the Test Configuration.



A D T

4.7.6 TEST RESULTS

CHANNEL	0	FREQUENCY RANGE	Below 1GHz
INPUT POWER	120Vac, 60 Hz	DETECTOR FUNCTION	Quasi-Peak Peak(PK) Average (AV)
ENVIRONMENTAL CONDITIONS	19deg. C, 64%RH, 1021 hPa	TESTED BY	Frank Liu

ANTENNA POLARITY & TEST DISTANCE: HORIZONTAL AT 3 M

No.	Freq. (MHz)	Emission Level (dBuV/m)	Limit (dBuV/m)	Margin (dB)	Antenna Height (m)	Table Angle (Degree)	Raw Value (dBuV)	Correction Factor (dB/m)
1	67.07	25.8 QP	40.00	-14.2	1.75 H	225	13.33	12.51
2	144.04	34.6 QP	43.50	-8.9	1.25 H	358	20.62	14.00
3	239.02	38.6 QP	46.00	-7.4	1.00 H	258	25.75	12.85
4	277.27	31.2 QP	46.00	-14.8	1.00 H	258	16.70	14.53
5	385.74	24.9 QP	46.00	-21.1	2.00 H	74	7.52	17.37
6	434.89	25.5 QP	46.00	-20.5	1.75 H	121	7.00	18.52
7	902.00	54.4 PK	101.90	-47.5	1.27 H	134	27.86	26.54
8	902.00	43.0 AV	90.50	-47.5	1.27 H	134	16.46	26.54
9	*902.75	121.9 PK			1.27 H	134	95.36	26.54
10	*902.75	110.5 AV			1.27 H	134	83.96	26.54

ANTENNA POLARITY & TEST DISTANCE: VERTICAL AT 3 M

No.	Freq. (MHz)	Emission Level (dBuV/m)	Limit (dBuV/m)	Margin (dB)	Antenna Height (m)	Table Angle (Degree)	Raw Value (dBuV)	Correction Factor (dB/m)
1	31.18	29.8 QP	40.00	-10.2	1.25 V	360	17.09	12.74
2	66.12	32.3 QP	40.00	-7.7	1.00 V	307	19.66	12.66
3	144.04	27.7 QP	43.50	-15.8	1.00 V	57	13.74	14.00
4	166.30	24.8 QP	43.50	-18.7	1.00 V	76	10.93	13.88
5	238.54	22.5 QP	46.00	-23.5	1.25 V	279	9.69	12.82
6	277.38	24.6 QP	46.00	-21.4	1.50 V	0	10.09	14.53
7	902.00	59.3 PK	108.80	-49.5	1.00 V	190	32.76	26.54
8	902.00	47.9 AV	97.40	-49.5	1.00 V	190	21.36	26.54
9	*902.75	128.8 PK			1.00 V	190	102.26	26.54
10	*902.75	117.4 AV			1.00 V	190	90.86	26.54

- REMARKS:**
1. Emission level(dBuV/m)=Raw Value(dBuV) + Correction Factor(dB/m)
 2. Correction Factor(dB/m) = Antenna Factor (dB/m) + Cable Factor (dB)
 3. The other emission levels were very low against the limit.
 4. Margin value = Emission level – Limit value.
 5. “ * “: Fundamental frequency.



A D T

CHANNEL	Channel 0	FREQUENCY RANGE	1 ~10GHz
INPUT POWER	120Vac, 60 Hz	DETECTOR FUNCTION	Peak(PK) Average (AV)
ENVIRONMENTAL CONDITIONS	18deg. C, 70%RH, 1021 hPa	TESTED BY	Frank Liu

ANTENNA POLARITY & TEST DISTANCE: HORIZONTAL AT 3 M

No.	Freq. (MHz)	Emission Level (dBuV/m)	Limit (dBuV/m)	Margin (dB)	Antenna Height (m)	Table Angle (Degree)	Raw Value (dBuV)	Correction Factor (dB/m)
1	2708.25	48.4 PK	74.00	-25.6	1.05 H	20	15.64	32.76
2	2708.25	37.0 AV	54.00	-17.0	1.05 H	20	4.24	32.76
3	3611.00	49.2 PK	74.00	-24.8	1.03 H	29	13.72	35.48
4	3611.00	37.8 AV	54.00	-16.2	1.03 H	29	2.32	35.48
5	4513.75	47.3 PK	74.00	-26.7	1.10 H	335	7.06	40.24
6	4513.75	35.9 AV	54.00	-18.1	1.10 H	335	-4.34	40.24
7	5416.50	49.4 PK	74.00	-24.6	1.00 H	246	7.53	41.87
8	5416.50	38.0 AV	54.00	-16.0	1.00 H	246	-3.87	41.87
9	8124.75	54.9 PK	74.00	-19.1	1.24 H	31	7.47	47.43
10	8124.75	43.5 AV	54.00	-10.5	1.24 H	31	-3.93	47.43
11	9027.50	54.7 PK	74.00	-19.3	1.00 H	42	6.76	47.94
12	9027.50	43.3 AV	54.00	-10.7	1.00 H	42	-4.64	47.94

ANTENNA POLARITY & TEST DISTANCE: VERTICAL AT 3 M

No.	Freq. (MHz)	Emission Level (dBuV/m)	Limit (dBuV/m)	Margin (dB)	Antenna Height (m)	Table Angle (Degree)	Raw Value (dBuV)	Correction Factor (dB/m)
1	2708.25	48.0 PK	74.00	-26.0	1.41 V	237	15.24	32.76
2	2708.25	36.6 AV	54.00	-17.4	1.41 V	237	3.84	32.76
3	3611.00	49.0 PK	74.00	-25.0	1.42 V	243	13.52	35.48
4	3611.00	37.6 AV	54.00	-16.4	1.42 V	243	2.12	35.48
5	4513.75	46.6 PK	74.00	-27.4	1.05 V	144	6.36	40.24
6	4513.75	35.2 AV	54.00	-18.8	1.05 V	144	-5.04	40.24
7	5416.50	49.2 PK	74.00	-24.8	1.03 V	241	7.33	41.87
8	5416.50	37.8 AV	54.00	-16.2	1.03 V	241	-4.07	41.87
9	8124.75	54.8 PK	74.00	-19.2	1.20 V	32	7.37	47.43
10	8124.75	43.4 AV	54.00	-10.6	1.20 V	32	-4.03	47.43
11	9027.50	55.6 PK	74.00	-18.4	1.17 V	43	7.66	47.94
12	9027.50	44.2 AV	54.00	-9.8	1.17 V	43	-3.74	47.94

- REMARKS:**
1. Emission level(dBuV/m)=Raw Value(dBuV) + Correction Factor(dB/m)
 2. Correction Factor(dB/m) = Antenna Factor (dB/m) + Cable Factor (dB)
 3. The other emission levels were very low against the limit.
 4. Margin value = Emission level – Limit value.



A D T

CHANNEL	24	FREQUENCY RANGE	Below 1GHz
INPUT POWER	120Vac, 60 Hz	DETECTOR FUNCTION	Quasi-Peak Peak(PK) Average (AV)
ENVIRONMENTAL CONDITIONS	19deg. C, 64%RH, 1021 hPa	TESTED BY	Frank Liu

ANTENNA POLARITY & TEST DISTANCE: HORIZONTAL AT 3 M

No.	Freq. (MHz)	Emission Level (dBuV/m)	Limit (dBuV/m)	Margin (dB)	Antenna Height (m)	Table Angle (Degree)	Raw Value (dBuV)	Correction Factor (dB/m)
1	67.07	25.6 QP	40.00	-14.4	1.75 H	213	13.06	12.51
2	144.04	34.6 QP	43.50	-8.9	1.25 H	360	20.57	14.00
3	239.02	38.2 QP	46.00	-7.8	1.00 H	249	25.38	12.85
4	277.27	31.6 QP	46.00	-14.4	1.00 H	256	17.04	14.53
5	385.74	24.5 QP	46.00	-21.5	2.00 H	58	7.15	17.37
6	434.89	25.4 QP	46.00	-20.6	1.75 H	67	6.85	18.52
7	*914.75	120.4 PK			1.25 H	143	93.86	26.54
8	*914.75	109.0 AV			1.25 H	143	82.46	26.54

ANTENNA POLARITY & TEST DISTANCE: VERTICAL AT 3 M

No.	Freq. (MHz)	Emission Level (dBuV/m)	Limit (dBuV/m)	Margin (dB)	Antenna Height (m)	Table Angle (Degree)	Raw Value (dBuV)	Correction Factor (dB/m)
1	31.18	29.6 QP	40.00	-10.4	1.25 V	303	16.89	12.73
2	66.12	32.5 QP	40.00	-7.5	1.00 V	324	19.87	12.66
3	144.04	27.4 QP	43.50	-16.1	1.00 V	123	13.42	14.00
4	166.30	24.8 QP	43.50	-18.7	1.00 V	156	10.90	13.88
5	238.54	22.4 QP	46.00	-23.6	1.25 V	246	9.61	12.82
6	277.38	24.6 QP	46.00	-21.4	1.50 V	23	10.05	14.53
7	*914.75	128.7 PK			1.00 V	194	102.16	26.54
8	*914.75	117.3 AV			1.00 V	194	90.76	26.54

- REMARKS:**
1. Emission level(dBuV/m)=Raw Value(dBuV) + Correction Factor(dB/m)
 2. Correction Factor(dB/m) = Antenna Factor (dB/m) + Cable Factor (dB)
 3. The other emission levels were very low against the limit.
 4. Margin value = Emission level – Limit value.
 5. “ * “: Fundamental frequency.



A D T

CHANNEL	Channel 24	FREQUENCY RANGE	1 ~10GHz
INPUT POWER	120Vac, 60 Hz	DETECTOR FUNCTION	Peak(PK) Average (AV)
ENVIRONMENTAL CONDITIONS	18deg. C, 70%RH, 1021 hPa	TESTED BY	Frank Liu

ANTENNA POLARITY & TEST DISTANCE: HORIZONTAL AT 3 M

No.	Freq. (MHz)	Emission Level (dBuV/m)	Limit (dBuV/m)	Margin (dB)	Antenna Height (m)	Table Angle (Degree)	Raw Value (dBuV)	Correction Factor (dB/m)
1	2744.25	45.4 PK	74.00	-28.6	1.04 H	28	12.53	32.87
2	2744.25	34.0 AV	54.00	-20.0	1.04 H	28	1.13	32.87
3	3659.00	51.4 PK	74.00	-22.6	1.04 H	93	15.72	35.68
4	3659.00	40.0 AV	54.00	-14.0	1.04 H	93	4.32	35.68
5	4573.75	46.8 PK	74.00	-27.2	1.22 H	235	6.39	40.41
6	4573.75	35.4 AV	54.00	-18.6	1.22 H	235	-5.01	40.41
7	7318.00	53.1 PK	74.00	-20.9	1.00 H	46	7.77	45.33
8	7318.00	41.7 AV	54.00	-12.3	1.00 H	46	-3.63	45.33
9	8232.75	53.5 PK	74.00	-20.5	1.00 H	32	6.11	47.39
10	8232.75	42.1 AV	54.00	-11.9	1.00 H	32	-5.29	47.39
11	9147.50	54.6 PK	74.00	-19.4	1.00 H	37	6.78	47.82
12	9147.50	43.2 AV	54.00	-10.8	1.00 H	37	-4.62	47.82

ANTENNA POLARITY & TEST DISTANCE: VERTICAL AT 3 M

No.	Freq. (MHz)	Emission Level (dBuV/m)	Limit (dBuV/m)	Margin (dB)	Antenna Height (m)	Table Angle (Degree)	Raw Value (dBuV)	Correction Factor (dB/m)
1	2744.25	46.2 PK	74.00	-27.8	1.34 V	243	13.33	32.87
2	2744.25	34.8 AV	54.00	-19.2	1.34 V	243	1.93	32.87
3	3659.00	53.1 PK	74.00	-20.9	1.30 V	258	17.42	35.68
4	3659.00	41.7 AV	54.00	-12.3	1.30 V	258	6.02	35.68
5	4573.75	46.5 PK	74.00	-27.5	1.00 V	19	6.09	40.41
6	4573.75	35.1 AV	54.00	-18.9	1.00 V	19	-5.31	40.41
7	7318.00	53.7 PK	74.00	-20.3	1.00 V	124	8.37	45.33
8	7318.00	42.3 AV	54.00	-11.7	1.00 V	124	-3.03	45.33
9	8232.75	52.6 PK	74.00	-21.4	1.01 V	121	5.21	47.39
10	8232.75	41.2 AV	54.00	-12.8	1.01 V	121	-6.19	47.39
11	9147.50	54.7 PK	74.00	-19.3	1.09 V	46	6.88	47.82
12	9147.50	43.3 AV	54.00	-10.7	1.09 V	46	-4.52	47.82

- REMARKS:**
1. Emission level(dBuV/m)=Raw Value(dBuV) + Correction Factor(dB/m)
 2. Correction Factor(dB/m) = Antenna Factor (dB/m) + Cable Factor (dB)
 3. The other emission levels were very low against the limit.
 4. Margin value = Emission level – Limit value.



A D T

CHANNEL	49	FREQUENCY RANGE	Below 1GHz
INPUT POWER	120Vac, 60 Hz	DETECTOR FUNCTION	Quasi-Peak Peak(PK) Average (AV)
ENVIRONMENTAL CONDITIONS	19deg. C, 64%RH, 1021 hPa	TESTED BY	Frank Liu

ANTENNA POLARITY & TEST DISTANCE: HORIZONTAL AT 3 M

No.	Freq. (MHz)	Emission Level (dBuV/m)	Limit (dBuV/m)	Margin (dB)	Antenna Height (m)	Table Angle (Degree)	Raw Value (dBuV)	Correction Factor (dB/m)
1	67.07	25.6 QP	40.00	-14.4	1.75 H	295	13.10	12.51
2	144.04	34.3 QP	43.50	-9.2	1.25 H	307	20.33	14.00
3	239.02	38.1 QP	46.00	-7.9	1.00 H	227	25.25	12.85
4	277.27	31.6 QP	46.00	-14.4	1.00 H	220	17.03	14.53
5	385.74	24.9 QP	46.00	-21.1	2.00 H	68	7.50	17.37
6	434.89	25.2 QP	46.00	-20.8	1.75 H	74	6.68	18.52
7	896.74	40.4 QP	46.00	-5.6	2.00 H	232	13.69	26.74
8	*927.25	119.3 PK			1.26 H	139	92.76	26.54
9	*927.25	107.9 AV			1.26 H	139	81.36	26.54
10	928.00	54.1 PK	99.30	-45.2	1.26 H	139	27.56	26.54
11	928.00	42.7 AV	87.90	-45.2	1.26 H	139	16.16	26.54

ANTENNA POLARITY & TEST DISTANCE: VERTICAL AT 3 M

No.	Freq. (MHz)	Emission Level (dBuV/m)	Limit (dBuV/m)	Margin (dB)	Antenna Height (m)	Table Angle (Degree)	Raw Value (dBuV)	Correction Factor (dB/m)
1	31.18	29.7 QP	40.00	-10.3	1.25 V	354	17.01	12.73
2	66.12	32.6 QP	40.00	-7.4	1.00 V	321	19.96	12.66
3	144.04	27.6 QP	43.50	-15.9	1.00 V	106	13.59	14.00
4	166.30	24.4 QP	43.50	-19.1	1.00 V	132	10.49	13.88
5	238.54	22.3 QP	46.00	-23.7	1.25 V	237	9.47	12.82
6	277.38	24.8 QP	46.00	-21.2	1.50 V	64	10.29	14.53
7	*927.25	128.2 PK			1.00 V	198	101.66	26.54
8	*927.25	116.8 AV			1.00 V	198	90.26	26.54
9	928.00	59.6 PK	108.20	-48.6	1.00 V	196	33.06	26.54
10	928.00	48.2 AV	96.80	-48.6	1.00 V	196	-21.66	26.54

- REMARKS:**
1. Emission level(dBuV/m)=Raw Value(dBuV) + Correction Factor(dB/m)
 2. Correction Factor(dB/m) = Antenna Factor (dB/m) + Cable Factor (dB)
 3. The other emission levels were very low against the limit.
 4. Margin value = Emission level – Limit value.
 5. " * ": Fundamental frequency.



A D T

CHANNEL	Channel 49	FREQUENCY RANGE	1 ~10GHz
INPUT POWER	120Vac, 60 Hz	DETECTOR FUNCTION	Peak(PK) Average (AV)
ENVIRONMENTAL CONDITIONS	18deg. C, 70%RH, 1021 hPa	TESTED BY	Frank Liu

ANTENNA POLARITY & TEST DISTANCE: HORIZONTAL AT 3 M

No.	Freq. (MHz)	Emission Level (dBuV/m)	Limit (dBuV/m)	Margin (dB)	Antenna Height (m)	Table Angle (Degree)	Raw Value (dBuV)	Correction Factor (dB/m)
1	2781.75	48.2 PK	74.00	-25.8	1.45 H	26	15.22	32.98
2	2781.75	36.8 AV	54.00	-17.2	1.45 H	26	3.82	32.98
3	3709.00	56.1 PK	74.00	-17.9	1.02 H	90	20.21	35.89
4	3709.00	44.7 AV	54.00	-9.3	1.02 H	90	8.81	35.89
5	4636.25	47.6 PK	74.00	-26.4	1.32 H	345	7.02	40.58
6	4636.25	36.2 AV	54.00	-17.8	1.32 H	345	-4.38	40.58
7	7418.00	56.4 PK	74.00	-17.6	1.00 H	213	10.77	45.63
8	7418.00	45.0 AV	54.00	-9.0	1.00 H	213	-0.63	45.63
9	8345.25	55.4 PK	74.00	-18.6	1.00 H	29	8.03	47.37
10	8345.25	44.0 AV	54.00	-10.0	1.00 H	29	-3.37	47.37

ANTENNA POLARITY & TEST DISTANCE: VERTICAL AT 3 M

No.	Freq. (MHz)	Emission Level (dBuV/m)	Limit (dBuV/m)	Margin (dB)	Antenna Height (m)	Table Angle (Degree)	Raw Value (dBuV)	Correction Factor (dB/m)
1	2781.75	47.2 PK	74.00	-26.8	1.42 V	257	14.22	32.98
2	2781.75	35.8 AV	54.00	-18.2	1.42 V	257	2.82	32.98
3	3709.00	55.9 PK	74.00	-18.1	1.25 V	256	20.01	35.89
4	3709.00	44.5 AV	54.00	-9.5	1.25 V	256	8.61	35.89
5	4636.25	47.1 PK	74.00	-26.9	1.00 V	225	6.52	40.58
6	4636.25	35.7 AV	54.00	-18.3	1.00 V	225	-4.88	40.58
7	7418.00	56.2 PK	74.00	-17.8	1.04 V	113	10.57	45.63
8	7418.00	44.8 AV	54.00	-9.2	1.04 V	113	-0.83	45.63
9	8345.25	53.6 PK	74.00	-20.4	1.07 V	211	6.23	47.37
10	8345.25	42.2 AV	54.00	-11.8	1.07 V	211	-5.17	47.37

- REMARKS:**
1. Emission level(dBuV/m)=Raw Value(dBuV) + Correction Factor(dB/m)
 2. Correction Factor(dB/m) = Antenna Factor (dB/m) + Cable Factor (dB)
 3. The other emission levels were very low against the limit.
 4. Margin value = Emission level – Limit value.

4.8 CONDUCTED OUT-BAND EMISSION MEASUREMENT

4.8.1 LIMITS OF CONDUCTED OUT-BAND EMISSION MEASUREMENT

Below -20dB of the highest emission level of operating band (in 100kHz RBW).

4.8.2 TEST INSTRUMENTS

DESCRIPTION & MANUFACTURER	MODEL NO.	SERIAL NO.	CALIBRATED DATE	CALIBRATED UNTIL
R&S SPECTRUM ANALYZER	FSP40	100037	Sep. 08, 2010	Sep. 07, 2011

NOTE:

- 1.The calibration interval of the above test instruments is 12 months and the calibrations are traceable to NML/ROC and NIST/USA.

4.8.3 TEST PROCEDURE

The transmitter output was connected to the spectrum analyzer via a low lose cable. Set both RBW and VBW of spectrum analyzer to 100 kHz with suitable frequency span including 20 MHz bandwidth from band edge. The band edges was measured and recorded.

4.8.4 DEVIATION FROM TEST STANDARD

No deviation

4.8.5 EUT OPERATING CONDITION

The software provided by client enabled the EUT to transmit and receive data at lowest, middle and highest channel frequencies individually.

4.8.6 TEST RESULTS

The spectrum plots are attached on the following 2 pages. D2 line indicates the highest level, D1 line indicates the 20dB offset below D2. It shows compliance with the requirement in part 15.247(C).

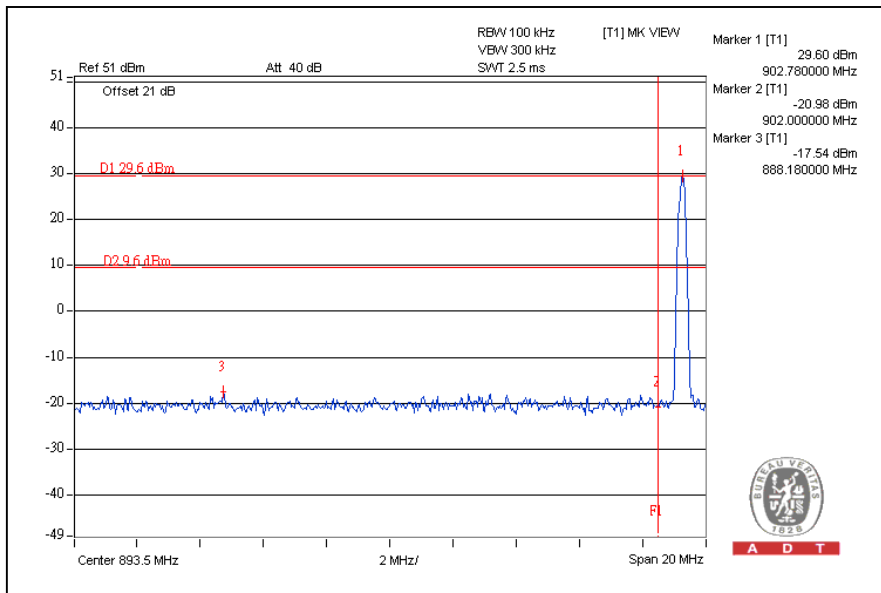
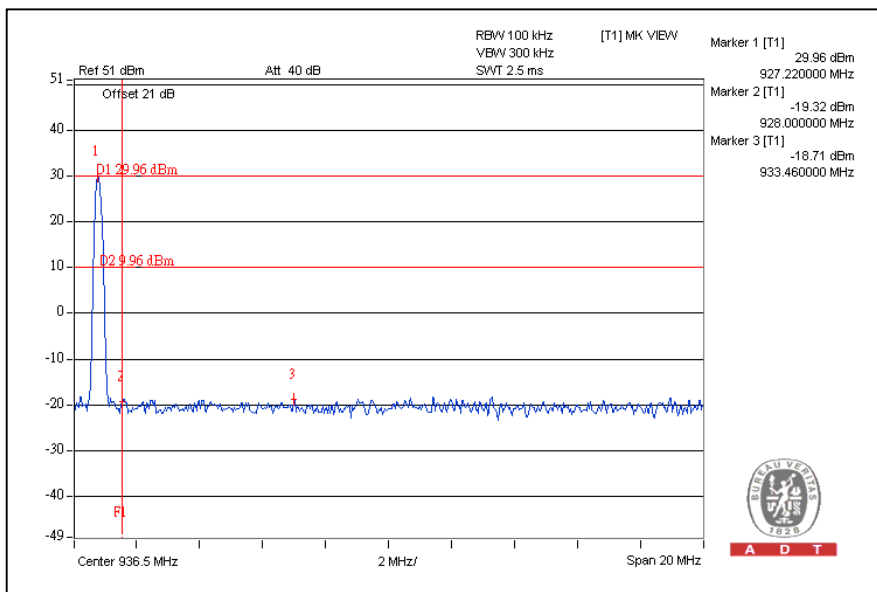
CH0

CH49

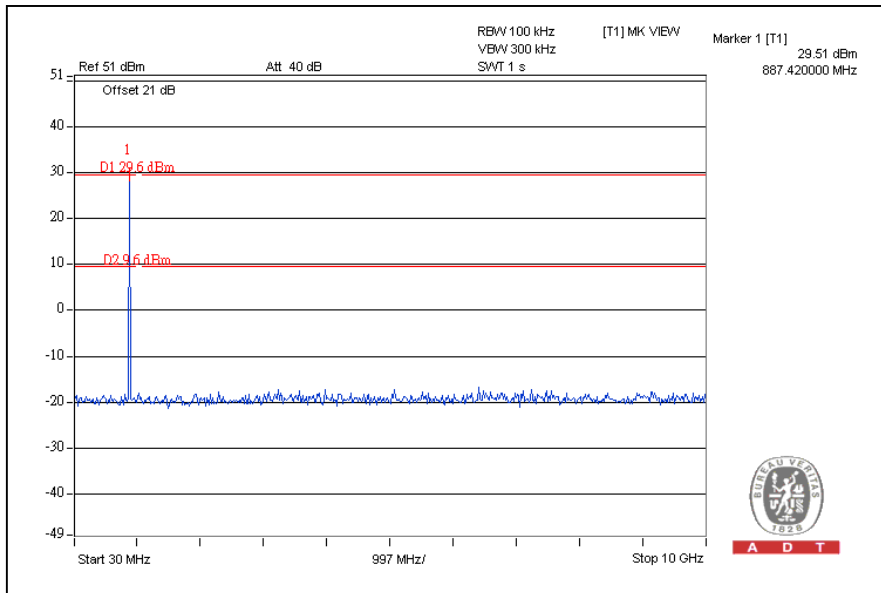

A D T

CH0



CH49

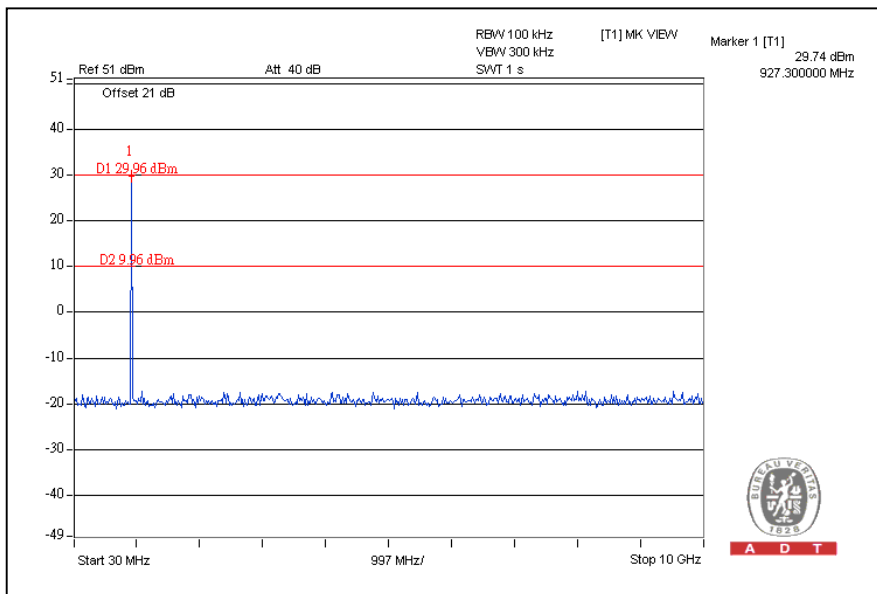



5 INFORMATION ON THE TESTING LABORATORIES

We, Bureau Veritas Consumer Products Services (H.K.) Ltd., Taoyuan Branch, were founded in 1988 to provide our best service in EMC, Radio, Telecom and Safety consultation. Our laboratories are accredited and approved according to ISO/IEC 17025.

Copies of accreditation certificates of our laboratories obtained from approval agencies can be downloaded from our web site: www.adt.com.tw/index.5.phtml.
If you have any comments, please feel free to contact us at the following:

Linko EMC/RF Lab:

Tel: 886-2-26052180

Fax: 886-2-26051924

Hsin Chu EMC/RF Lab:

Tel: 886-3-5935343

Fax: 886-3-5935342

Hwa Ya EMC/RF/Safety/Telecom Lab: Web Site: www.adt.com.tw

Tel: 886-3-3183232

Fax: 886-3-3185050

The address and road map of all our labs can be found in our web site also.

6 APPENDIX A - MODIFICATIONS RECORDERS FOR ENGINEERING CHANGES TO THE EUT BY THE LAB

No any modifications are made to the EUT by the lab during the test.

--- END ---