



FCC TEST REPORT (Bluetooth)

REPORT NO.: RF980729H05-2

MODEL NO.: MC3190

RECEIVED: July 29, 2009

TESTED: Aug. 31 to Sep. 03, 2009

ISSUED: Sep. 16, 2009

APPLICANT: Motorola Inc.

ADDRESS: One Motorola Plaza
Holtsville NY 11742-1300
USA

ISSUED BY: Bureau Veritas Consumer Products Services
(H.K.) Ltd., Taoyuan Branch

LAB LOCATION: No. 81-1, Lu Liao Keng, 9th Ling, Wu Lung
Tsuen, Chung Lin Hsiang, Hsin Chu Hsien 307,
Taiwan

This test report consists of 81 pages in total. It may be duplicated completely for legal use with the approval of the applicant. It should not be reproduced except in full, without the written approval of our laboratory. The client should not use it to claim product endorsement by TAF or any government agencies. The test results in the report only apply to the tested sample.





TABLE OF CONTENTS

1	CERTIFICATION.....	4
2	SUMMARY OF TEST RESULTS.....	5
2.1	MEASUREMENT UNCERTAINTY	6
3	GENERAL INFORMATION.....	7
3.1	GENERAL DESCRIPTION OF EUT.....	7
3.2	DESCRIPTION OF TEST MODES.....	12
3.3	TEST MODE APPLICABILITY AND TESTED CHANNEL DETAIL:	13
3.4	GENERAL DESCRIPTION OF APPLIED STANDARDS.....	15
3.5	DESCRIPTION OF SUPPORT UNITS	16
3.6	CONFIGURATION OF SYSTEM UNDER TEST	17
4	TEST PROCEDURES AND RESULTS.....	20
4.1	CONDUCTED EMISSION MEASUREMENT.....	20
4.1.1	LIMITS OF CONDUCTED EMISSION MEASUREMENT	20
4.1.2	TEST INSTRUMENTS	20
4.1.3	TEST PROCEDURES.....	21
4.1.4	TEST SETUP	21
4.1.5	EUT OPERATING CONDITIONS.....	22
4.1.6	TEST RESULTS	23
4.2	NUMBER OF HOPPING FREQUENCY USED.....	29
4.2.1	LIMIT OF HOPPING FREQUENCY USED.....	29
4.2.2	TEST INSTRUMENTS	29
4.2.3	TEST PROCEDURES.....	29
4.2.4	DEVIATION FROM TEST STANDARD	29
4.2.5	TEST SETUP	30
4.2.6	TEST RESULTS	30
4.3	DWELL TIME ON EACH CHANNEL	34
4.3.1	LIMIT OF DWELL TIME USED	34
4.3.2	TEST INSTRUMENTS	34
4.3.3	TEST PROCEDURES.....	34
4.3.4	DEVIATION FROM TEST STANDARD	35
4.3.5	TEST SETUP	35
4.3.6	TEST RESULTS	35
4.4	CHANNEL BANDWIDTH.....	39
4.4.1	LIMITS OF CHANNEL BANDWIDTH	39
4.4.2	TEST INSTRUMENTS	39
4.4.3	TEST PROCEDURE	39
4.4.4	DEVIATION FROM TEST STANDARD	39
4.4.5	TEST SETUP	40
4.4.6	EUT OPERATING CONDITION.....	40
4.4.7	TEST RESULTS	41
4.5	HOPPING CHANNEL SEPARATION	47
4.5.1	LIMIT OF HOPPING CHANNEL SEPARATION.....	47
4.5.2	TEST INSTRUMENTS	47



4.5.3	TEST PROCEDURES.....	47
4.5.4	DEVIATION FROM TEST STANDARD	48
4.5.5	TEST SETUP	48
4.5.6	TEST RESULTS	49
4.6	MAXIMUM PEAK OUTPUT POWER	55
4.6.1	LIMITS OF MAXIMUM PEAK OUTPUT POWER MEASUREMENT	55
4.6.2	INSTRUMENTS.....	55
4.6.3	TEST PROCEDURES.....	55
4.6.4	DEVIATION FROM TEST STANDARD	55
4.6.5	TEST SETUP	56
4.6.6	EUT OPERATING CONDITION.....	56
4.6.7	TEST RESULTS	57
4.7	RADIATED EMISSION MEASUREMENT.....	63
4.7.1	LIMITS OF RADIATED EMISSION MEASUREMENT	63
4.7.2	TEST INSTRUMENTS	64
4.7.3	TEST PROCEDURES.....	65
4.7.4	DEVIATION FROM TEST STANDARD	65
4.7.5	TEST SETUP	66
4.7.6	TEST RESULTS	67
4.8	CONDUCTED OUT-BAND EMISSION MEASUREMENT	74
4.8.1	LIMITS OF CONDUCTED OUT-BAND EMISSION MEASUREMENT	74
4.8.2	TEST INSTRUMENTS	74
4.8.3	TEST PROCEDURE	74
4.8.4	DEVIATION FROM TEST STANDARD	74
4.8.5	EUT OPERATING CONDITION.....	74
4.8.6	TEST RESULTS	75
4.9	ANTENNA REQUIREMENT	79
4.9.1	STANDARD APPLICABLE	79
4.9.2	ANTENNA CONNECTED CONSTRUCTION.....	79
5	INFORMATION ON THE TESTING LABORATORIES	80
6	APPENDIX A - MODIFICATIONS RECORDERS FOR ENGINEERING CHANGES TO THE EUT BY THE LAB	81



1 CERTIFICATION

PRODUCT : Mobile Computer
BRAND NAME : MOTOROLA
MODEL NO. : MC3190
APPLICANT : Motorola Inc.
TESTED DATE : Aug. 31 to Sep. 03, 2009
TEST SAMPLE : ENGINEERING SAMPLE
STANDARDS : 47 CFR Part 15, Subpart C (Section 15.247),
ANSI C63.4-2003

The above equipment has been tested by **Bureau Veritas Consumer Products Services (H.K.) Ltd., Taoyuan Branch**, and found compliance with the requirement of the above standards. The test record, data evaluation & Equipment Under Test (EUT) configurations represented herein are true and accurate accounts of the measurements of the sample's EMC characteristics under the conditions specified in this report.

PREPARED BY : Carol Liao , **DATE:** Sep. 16, 2009
(Carol Liao, Specialist)

TECHNICAL ACCEPTANCE : Hank Chung , **DATE:** Sep. 16, 2009
Responsible for RF (Hank Chung, Deputy Manager)

APPROVED BY : May Chen , **DATE:** Sep. 16, 2009
(May Chen, Deputy Manager)

2 SUMMARY OF TEST RESULTS

The EUT has been tested according to the following specifications:

APPLIED STANDARD: 47 CFR Part 15, Subpart C			
Standard Section	Test Type and Limit	Result	REMARK
15.207	AC Power Conducted Emission	PASS	Meet the requirement of limit Minimum passing margin is -13.21dB at 0.162MHz
15.247(a)(1)(I)-(ii)	Number of Hopping Frequency Used Spec.: At least 15 channels	PASS	Meet the requirement of limit
15.247(a)(1)(ii)	Dwell Time on Each Channel Spec.: Max. 0.4 second within 31.6 second	PASS	Meet the requirement of limit
15.247(a)(1)(I)-(ii)	Hopping Channel Separation Spec. : Min. 25 kHz or two-thirds of 20 dB bandwidth, which ever is greater	PASS	Meet the requirement of limit
15.247(a)(2)	Spectrum Bandwidth of a Frequency Hopping Sequence Spread Spectrum System	PASS	Meet the requirement of limit
15.247(b)	Maximum Peak Output Power Spec.: max. 125mW	PASS	Meet the requirement of limit
15.247(c)	Transmitter Radiated Emissions Spec.: Table 15.209	PASS	Meet the requirement of limit Minimum passing margin is -9.18dB at 40.12MHz
15.247(c)	Conducted Out-Band Emissions Measurement	PASS	Meet the requirement of limit

NOTE:

1. There are Bluetooth technology and WLAN technology used for the EUT.
2. This report was recorded the Bluetooth technology.
3. For WLAN technology, the test data please refer "RF980729H05" and "RF980729H05-1".

2.1 MEASUREMENT UNCERTAINTY

Where relevant, the following measurement uncertainty levels have been estimated for tests performed on the EUT as specified in CISPR 16-4-2:

This uncertainty represents an expanded uncertainty expressed at approximately the 95% confidence level using a coverage factor of $k=2$.

Measurement	Value
Conducted emissions	2.44 dB
Radiated emissions (30MHz-1GHz)	3.94 dB
Radiated emissions (1GHz ~18GHz)	2.49 dB
Radiated emissions (18GHz ~20GHz)	2.70 dB

3 GENERAL INFORMATION

3.1 GENERAL DESCRIPTION OF EUT

PRODUCT	Mobile Computer
MODEL NO.	MC3190
FCC ID	UZ7MC3190
POWER SUPPLY	DC 12V to cradle, DC 5.4V from power adapter or DC 3.7V from battery
MODULATION TYPE	For WLAN : CCK, DQPSK, DBPSK for DSSS 64QAM, 16QAM, QPSK, BPSK for OFDM
	For Bluetooth : GFSK, $\pi/4$ – DQPSK, 8DPSK
MODULATION TECHNOLOGY	For WLAN : DSSS, OFDM
	For Bluetooth : FHSS
TRANSFER RATE	For WLAN : 802.11b: 11 / 5.5 / 2 / 1Mbps 802.11g: 54 / 48 / 36 / 24 / 18 / 12 / 9 / 6Mbps 802.11a: 54 / 48 / 36 / 24 / 18 / 12 / 9 / 6Mbps
	For Bluetooth : DH 1, DH 3, DH 5
FREQUENCY RANGE	For WLAN : For 15.407 802.11a: 5.18 ~ 5.32GHz, 5.50 ~ 5.70GHz For 15.247(2.4GHz) 802.11b & 802.11g: 2412 ~ 2462MHz For 15.247(5GHz) 802.11a: 5.745 ~ 5.825GHz
	For Bluetooth :2402MHz ~ 2480MHz
NUMBER OF CHANNEL	For WLAN : For 15.407 19 for 802.11a For 15.247(2.4GHz) 11 for 802.11b, 802.11g For 15.247(5GHz) 5 for 802.11a
	For Bluetooth : 79



MAXIMUM OUTPUT POWER	For WLAN : For 15.407 802.11a: 28.510mW For 15.247(2.4GHz) 802.11b: 52.360mW 802.11g: 165.959mW For 15.247(5GHz) 802.11a: 127.644mW
	For Bluetooth : GFSK: 1.445 mW 8DPSK: 2.449 mW $\pi/4$ – DQPSK: 2.265 mW
ANTENNA TYPE	Please see note 4
DATA CABLE	RS232 Cable x 1 (Part No.: 25-67866-03R) USB Cable x 1 (Part No.: 25-67868-03R) (only for test, not for sale together)
I/O PORTS	USB port x 1, SD slot port x 1, Audio port x 1
ASSOCIATED DEVICES	Battery x 1 for MC3190 (S & G) (Model No.: 82-127909-02) Battery x 1 for MC3190(R) (Model No.: 82-127912-01)

NOTE:

1. There are Bluetooth technology (BT2.1+EDR) and WLAN technology used for the EUT. <the WLAN test data please refer "RF980729H05" and "RF980729H05-1">
2. There are different types in MC3190, which with identical WLAN module and Bluetooth module in inside.
3. The EUT was pre-tested under the following modes:

Test Mode	Description
Mode A	X-Y plane
Mode B	Z-X plane
Mode C	Z-Y plane

From the above modes, the worst emission level was found in **Mode C**. Therefore only the test data of the modes were recorded in this report individually.



4. There are nine antennas provided to this EUT, please refer to the following table:

For WLAN								
No.	Brand	Model	Antenna Type	Gain (dBi)	Connector Type	Frequency range (MHz)	Cable Loss(dB)	Cable Length
1	Laird (R Type)	Rot main	PIFA	0.37(2.4G) 4.81(5G)	Hirose U.FL	2400~2500 4900~5850	0.1~0.15	25 ± 0.5mm
2	Laird (R Type)	Rot aux	PIFA	1.63(2.4G) 4.93(5G)	Hirose U.FL	2400~2500 4900~5850	0.1~0.15	61 +2/-1mm
3	Laird (S Type)	Str main	PIFA	0.89(2.4G) 4.34(5G)	Hirose U.FL	2400~2500 4900~5850	0.1~0.15	25 ± 0.5mm
4	Laird (S Type)	Str aux	PIFA	1.09(2.4G) 4.52(5G)	Hirose U.FL	2400~2500 4900~5850	0.1~0.15	61 +2/-1mm
5	Laird (G Type)	Gun main	PIFA	2.16(2.4G) 5.83(5G)	Hirose U.FL	2400~2500 4900~5850	0.1~0.15	25 ± 0.5mm
6	Laird (G Type)	Gun aux	PIFA	2.46(2.4G) 5.69(5G)	Hirose U.FL	2400~2500 4900~5850	0.1~0.15	61 +2/-1mm

Note :

- For 2.4G: The antenna 6 was selected as representative antenna for the test.
- For 5G: The antenna 5 was selected as representative antenna for the test.

For Bluetooth

No.	Brand	Model	Antenna Type	Gain (dBi)	Connector Type	Frequency range (MHz)	Cable Loss(dB)	Cable Length
1	Motorola	Rot type	PIFA	3.08	Hirose U.FL	2400~2480	0.1~0.15	35 ± 0.5mm
2	Motorola	Str type	PIFA	2.481	Hirose U.FL	2400~2480	0.1~0.15	35 ± 0.5mm
3	Motorola	Gun type	PIFA	2.885	Hirose U.FL	2400~2480	0.1~0.15	35 ± 0.5mm

5. EUT Configuration:

	Straight type	Gun Type	Rotating type
	Type1	Type2_2	Type3
OS	WM6.1	WM6.1	WM6.1
CPU	624MHZ	624MHZ	624MHZ
RAM	128MB	128MB	128MB
Flash	512MB	512MB	512MB
Keypad	48keys	28keys	38keys
Battery	(Motorola)	(Motorola)	(Motorola)
Scan Engine	SE4500 SRBB (imager)	SE950	SE4500 HDBB DPM (imager)
wifi ANT	Str main/Str aux	Gun main/Gun aux	Rot main/Rot aux
WLAN (a/b/g)	V	V	V
BT	V	V	V

6. The EUT could be supplied with the a charger, power adapter and Li-ion battery as below:

Cradle 1 (1-slot) (only for test, not for sale together)	
Brand:	SYMBOL
Part No.:	CRD3000-1001RR
Input power :	+12V-----3.3A
I/O Ports:	USB Port x 1 RJ-45(console) Port x 1
Associated devices:	USB cable x 1 (Part No.: 25-68596-01R) (1.6m, Unshielded without core) RJ-45(console) cable x 1 (Part No.: 25-63852-01R) (1.8m, Unshielded without core) Adapter x 1 (Part No.: 50-14000-148R)
Cradle 2 (4-slot) (only for test, not for sale together)	
Brand:	SYMBOL
Part No.:	CRD3000-4001ER
Input power :	+12V-----9A
I/O Ports:	RJ-45(LAN) Port x 2
Associated devices:	Power cable x 2 (Part No.: 50-16002-042R) (1.8m, Shielded with two cores) Adapter x 2 (Part No.: 50-14000-241R)
Adapter 1 (only for Cradle 1 use, not for sale together)	
Brand:	HIPRO
Model No.:	HP-O2040D43
Part No.:	50-14000-148R
Input power :	100-240V, 50-60Hz, 1.5A
Output power :	+12V-----3.33A DC output cable (1.8m, Unshielded)
Adapter 2 (only for Cradle 2 use, not for sale together)	
Brand:	SYMBOL
Model No.:	SYM04-1
Part No.:	50-14000-241R
Input power :	100-120/200-240V, 50-60Hz, 3.0/1.5A
Output power :	+12V-----9.0A



A D T

Adapter 3 (only for test, not for sale together)	
Brand:	DELTA
Model No.:	ADP-16GB A
Part No.:	50-14000-147
Input power :	100-240V, 50-60Hz, 0.4A
Output power :	+5.4V----3.0A DC output cable (1.8m, Unshielded, with one core)
Adapter 4 (only for test, not for sale together)	
Brand:	MOTOROLA
Model No.:	EADP-16BB A
Part No.:	50-14000-249R
Input power :	100-240V, 50-60Hz, 0.4A
Output power :	+5.4V----3.0A DC output cable (1.8m, Unshielded)

7. The EUT operates in both the 5GHz and 2.4GHz Bands and compatibility with 802.11a, 802.11b, 802.11g and Bluetooth technology.
8. The above EUT information was declared by the manufacturer and for more detailed features description, please refer to the manufacturer's specifications or User's Manual.



3.2 DESCRIPTION OF TEST MODES

Seventy-nine channels are provided to this EUT.

Channel	Freq. (MHz)	Channel	Freq. (MHz)	Channel	Freq. (MHz)	Channel	Freq. (MHz)
0	2402	20	2422	40	2442	60	2462
1	2403	21	2423	41	2443	61	2463
2	2404	22	2424	42	2444	62	2464
3	2405	23	2425	43	2445	63	2465
4	2406	24	2426	44	2446	64	2466
5	2407	25	2427	45	2447	65	2467
6	2408	26	2428	46	2448	66	2468
7	2409	27	2429	47	2449	67	2469
8	2410	28	2430	48	2450	68	2470
9	2411	29	2431	49	2451	69	2471
10	2412	30	2432	50	2452	70	2472
11	2413	31	2433	51	2453	71	2473
12	2414	32	2434	52	2454	72	2474
13	2415	33	2435	53	2455	73	2475
14	2416	34	2436	54	2456	74	2476
15	2417	35	2437	55	2457	75	2477
16	2418	36	2438	56	2458	76	2478
17	2419	37	2439	57	2459	77	2479
18	2420	38	2440	58	2460	78	2480
19	2421	39	2441	59	2461		

3.3 TEST MODE APPLICABILITY AND TESTED CHANNEL DETAIL:

The device has several types and different accessory, therefore the worst case base on investigation by different combination for each test item and its data was recorded in this report.

EUT CONFIGURE MODE	APPLICABLE TO				DESCRIPTION
	PLC	RE < 1G	RE ≥ 1G	APCM	
A	√		√	√	USB Mode: Type3 MC3190+Battery+Adapter(motorola)
B	√				cradle mode: (1-slot)Type3 MC3190+Battery+Adapter
C	√	√			cradle mode: (4-slot) 2*(Type3 MC3190+Battery) +2*(Type2_2 MC3190+Battery)+Adapter

Where **PLC**: Power Line Conducted Emission

RE < 1G: Radiated Emission below 1GHz

RE ≥ 1G: Radiated Emission above 1GHz

APCM: Antenna Port Conducted Measurement

Power Line Conducted Emission Test:

- Pre-Scan has been conducted to determine the worst-case mode from all possible combinations between available modulations, data rates and antenna ports (if EUT with antenna diversity architecture).
- Following channel(s) was (were) selected for the final test as listed below.

Available Channel	Tested Channel	Modulation Technology	Modulation Type	Packet Type	EUT CONFIGURE MODE
0 to 78	78	FHSS	8DPSK	DH5	A, B, C

Radiated Emission Test (Below 1 GHz):

- Pre-Scan has been conducted to determine the worst-case mode from all possible combinations between available modulations, data rates and antenna ports (if EUT with antenna diversity architecture).
- Following channel(s) was (were) selected for the final test as listed below.

Available Channel	Tested Channel	Modulation Technology	Modulation Type	Packet Type	EUT CONFIGURE MODE
0 to 78	0	FHSS	8DPSK	DH5	C

Radiated Emission Test (Above 1 GHz):

- Pre-Scan has been conducted to determine the worst-case mode from all possible combinations between available modulations, data rates and antenna ports (if EUT with antenna diversity architecture).
- Following channel(s) was (were) selected for the final test as listed below.

Available Channel	Tested Channel	Modulation Technology	Modulation Type	Packet Type	EUT CONFIGURE MODE
0 to 78	0, 39, 78	FHSS	GFSK	DH5	A
0 to 78	0, 39, 78	FHSS	8DPSK	DH5	A

Conducted Out-Band Measurement:

- Pre-Scan has been conducted to determine the worst-case mode from all possible combinations between available modulations, data rates and antenna ports (if EUT with antenna diversity architecture).
- Following channel(s) was (were) selected for the final test as listed below.

Available Channel	Tested Channel	Modulation Technology	Modulation Type	Packet Type	EUT CONFIGURE MODE
0 to 78	0, 78	FHSS	GFSK	DH5	A
0 to 78	0, 78	FHSS	8DPSK	DH5	A

Antenna Port Conducted Measurement:

- Pre-Scan has been conducted to determine the worst-case mode from all possible combinations between available modulations, data rates and antenna ports (if EUT with antenna diversity architecture).
- Following channel(s) was (were) selected for the final test as listed below.

Available Channel	Tested Channel	Modulation Technology	Modulation Type	Packet Type	EUT CONFIGURE MODE
0 to 78	0, 39, 78	FHSS	GFSK	DH5	A
0 to 78	0, 39, 78	FHSS	8DPSK	DH5	A
0 to 78	0, 39, 78	FHSS	$\pi/4$ -DQPSK	DH5	A



3.4 GENERAL DESCRIPTION OF APPLIED STANDARDS

The EUT is a Mobile Computer. According to the specifications of the manufacturer, it must comply with the requirements of the following standards:

FCC Part 15, Subpart C. (15.247)

ANSI C63.4 : 2003

All test items have been performed and recorded as per the above standards.

NOTE: The EUT is also considered as a kind of computer peripheral, because the connection to computer is necessary for typical use. It has been verified to comply with the requirements of FCC Part 15, Subpart B, Class B (DoC). The test report has been issued separately.

3.5 DESCRIPTION OF SUPPORT UNITS

The EUT has been tested as an independent unit together with other necessary accessories or support units. The following support units or accessories were used to form a representative test configuration during the tests.

NO.	PRODUCT	BRAND	MODEL NO.	SERIAL NO.	FCC ID
1	NOTEBOOK COMPUTER	DELL	PP19L	CN-OHC416-7016 6-5CA-0448	PIW632500516610
2	NOTEBOOK COMPUTER	DELL	PP17L	CN-ONF743-48643 -7AV-0124	FCC DoC
3	EARPHONE	SYMBOL	NA	NA	NA
4	SD CARD	Transcend	NA	NA	NA
5	BATTERY	SYMBOL	55-060112-05	N/A	NA
6	IPOD	APPLE	A1137	6U6078FMUPR	FCC DOC

No.	Signal cable description
1	NA
2	NA
3	1.3 m wrapped unshielded wire, terminated via drain wire, with 3.5 mm phone plug, w/o core.
4	NA
5	NA
6	1.2 m foil shielded wire, USB connector, w/o core.

Note: 1. All power cords of the above support units are unshielded (1.8m).

3.6 CONFIGURATION OF SYSTEM UNDER TEST

For USB Mode:

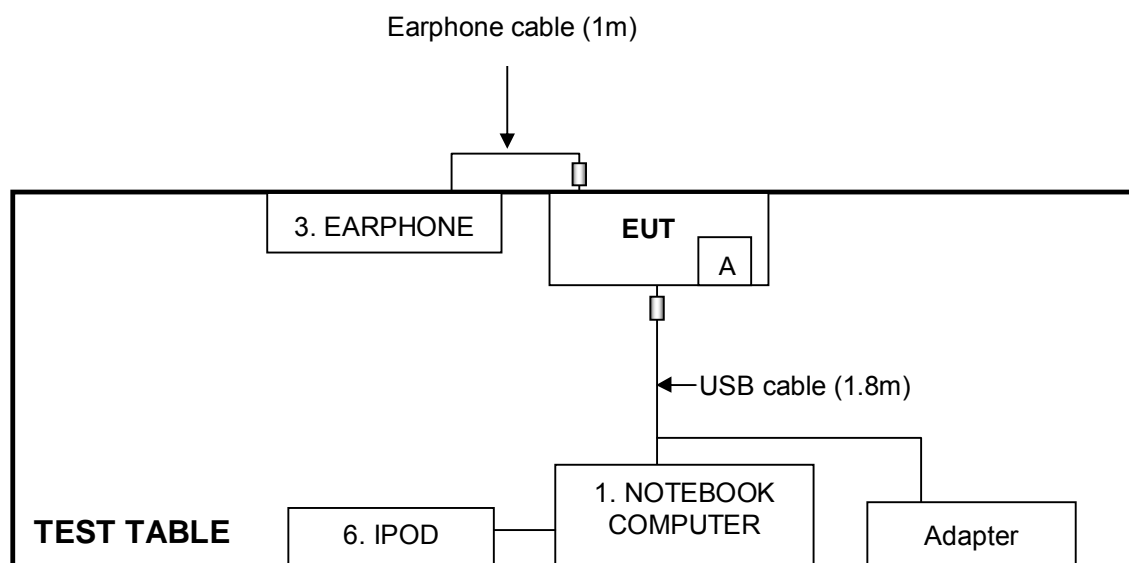

NOTE: 1. Item A is the SD Card (Support unit 4).

For Cradle (1 Slot) Mode:

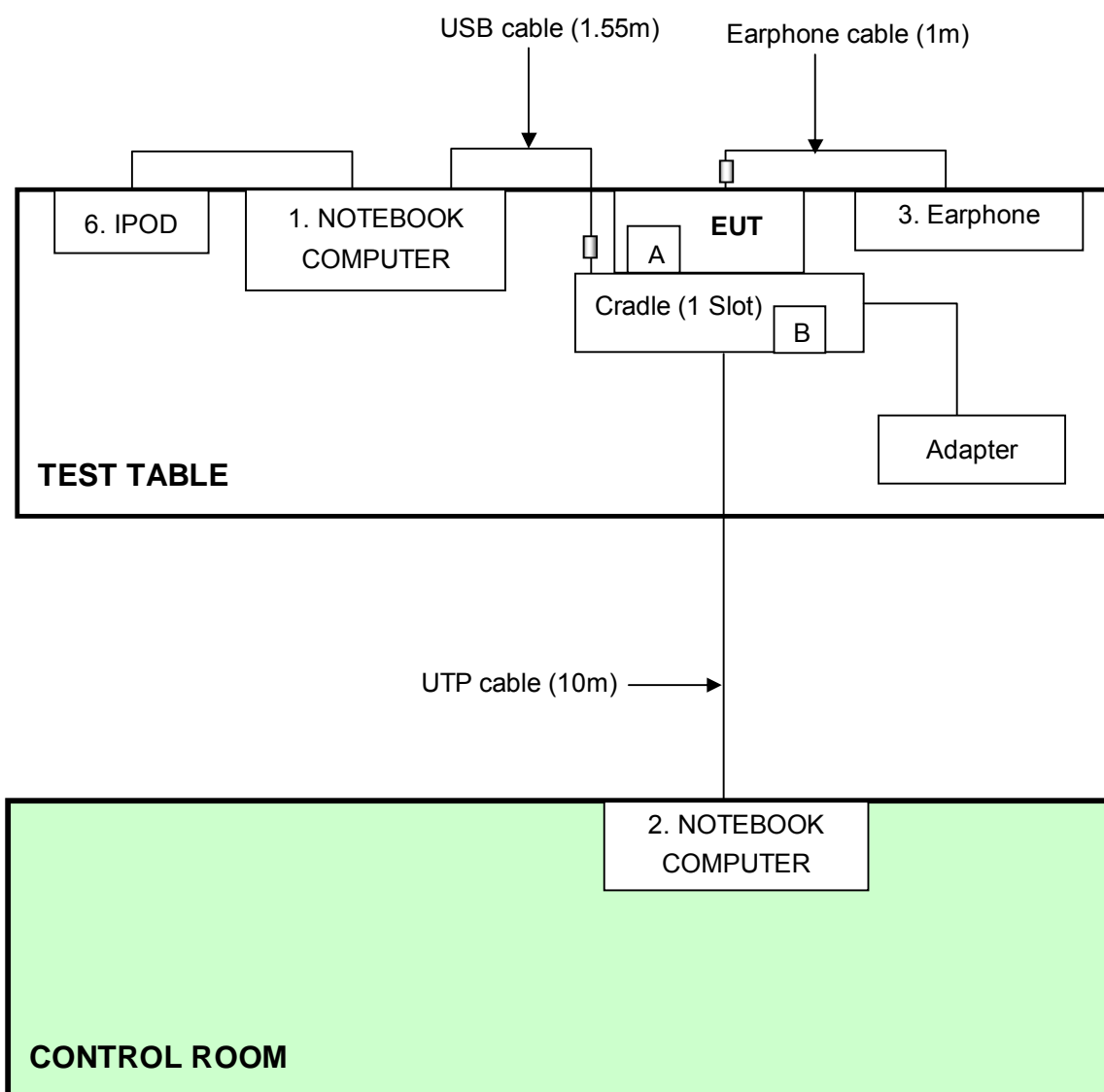

NOTE: 1. Item A is the SD Card (Support unit 4).
 2. Item B is the Battery (Support unit 5).

For Cradle (4 Slot) Mode:

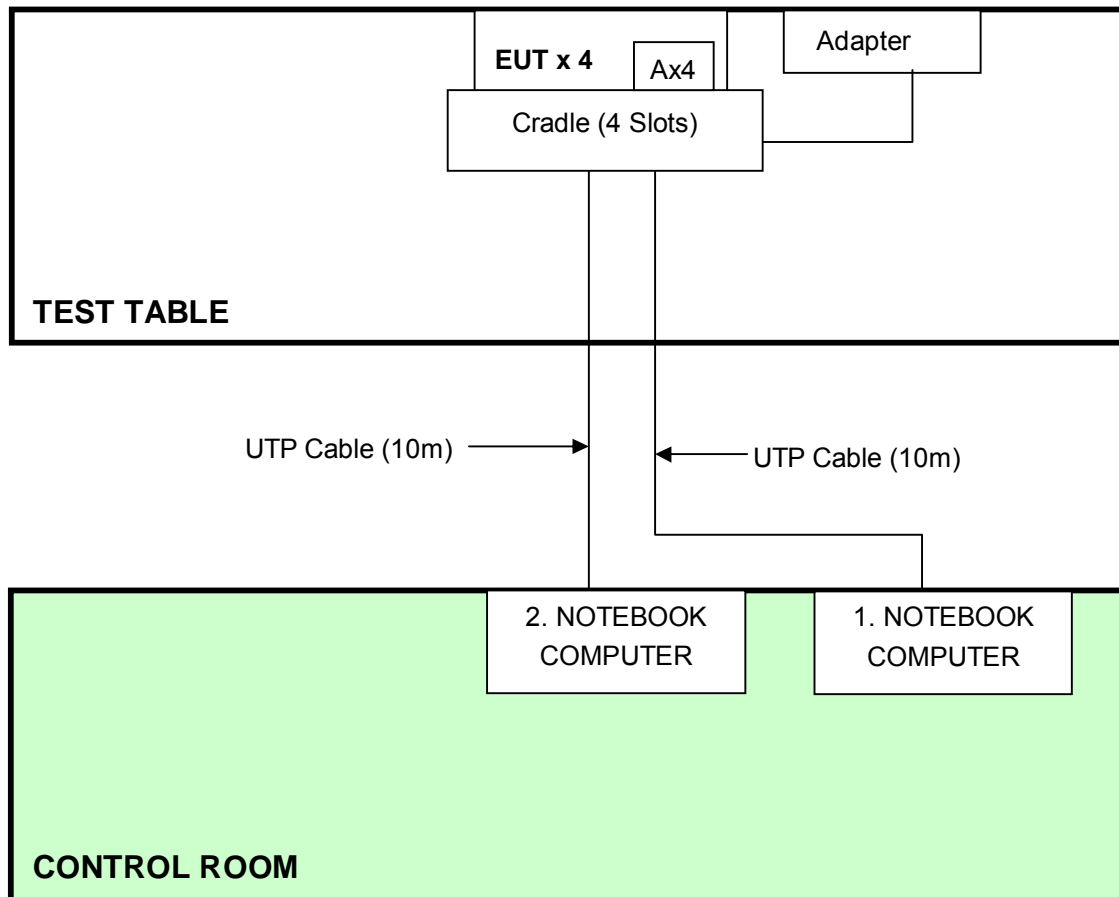

NOTE: 1. Item A is the SD Card (Support unit 4).

4 TEST PROCEDURES AND RESULTS

4.1 CONDUCTED EMISSION MEASUREMENT

4.1.1 LIMITS OF CONDUCTED EMISSION MEASUREMENT

FREQUENCY OF EMISSION (MHz)	CONDUCTED LIMIT (dB μ V)	
	Quasi-peak	Average
0.15-0.5	66 to 56	56 to 46
0.5-5	56	46
5-30	60	50

NOTE:

1. The lower limit shall apply at the transition frequencies.
2. All emanations from a class B digital device or system, including any network of conductors and apparatus connected thereto, shall not exceed the level of field strengths specified above.

4.1.2 TEST INSTRUMENTS

DESCRIPTION & MANUFACTURER	MODEL NO.	SERIAL NO.	CALIBRATED DATE	CALIBRATED UNTIL
Test Receiver	ESCS 30	100375	Mar. 23, 2009	Mar. 22, 2010
Line-Impedance Stabilization Network (for Peripheral)	ENV-216	100071	Nov. 26, 2008	Nov. 25, 2009
Line-Impedance Stabilization Network (for EUT)	ESH3-Z5	848773/004	Nov. 05, 2008	Nov. 04, 2009
RF Cable (JYEBAO)	5DFB	COBCAB-001	Aug. 15, 2009	Aug. 14, 2010
50 ohms Terminator	50	3	Nov. 05, 2008	Nov. 04, 2009
Software	BV ADT_Cond_V7.3.7	NA	NA	NA

Note:

1. The calibration interval of the above test instruments is 12 months and the calibrations are traceable to NML/ROC and NIST/USA.
2. The test was performed in Shielded Room No. B.
3. The VCCI Con B Registration No. is C-2193.

4.1.3 TEST PROCEDURES

- a. The EUT/HOST was placed 0.4 meters from the conducting wall of the shielded room with EUT/HOST being connected to the power mains through a line impedance stabilization network (LISN). Other support units were connected to the power mains through another LISN. The two LISNs provide 50 ohm/ 50uH of coupling impedance for the measuring instrument.
- b. Both lines of the power mains connected to the EUT/HOST were checked for maximum conducted interference.
- c. The frequency range from 150 kHz to 30 MHz was searched. Emission levels over 10dB under the prescribed limits could not be reported

4.1.4 TEST SETUP

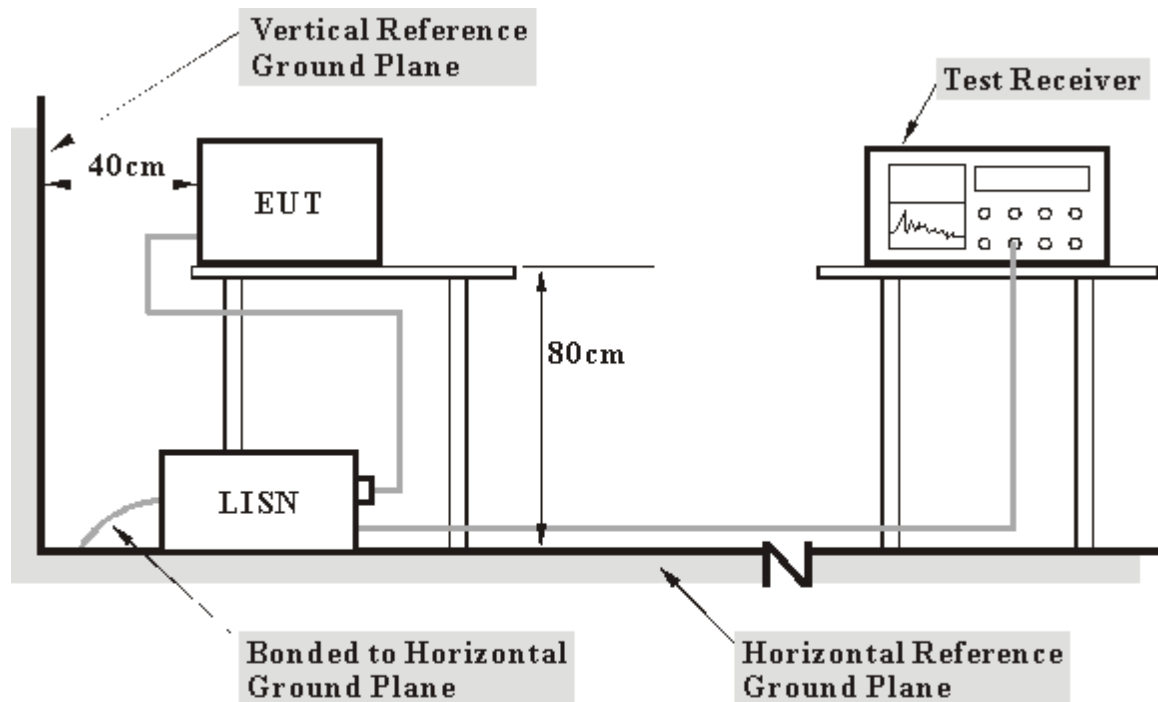

- Note:**
1. Support units were connected to second LISN.
 2. Both of LISNs (AMN) 80 cm from EUT and at the least 80 cm from other units and other metal planes support units.

For the actual test configuration, please refer to the related item – Photographs of the Test Configuration.

4.1.5 EUT OPERATING CONDITIONS

For USB Mode:

1. Set the EUT under charger condition via USB charging cable.
2. EUT runs the test program "BTRegTest ver3.5.exe" to transmission/receiving condition continuously.

For Cradle Mode:

1. Set the EUT under charger condition via cradle.
2. EUT runs the test program "BTRegTest ver3.5.exe" to transmission/receiving condition continuously.

4.1.6 TEST RESULTS

For USB Mode

INPUT POWER (SYSTEM)	120Vac, 60 Hz	6DB BANDWIDTH	9 kHz
ENVIRONMENTAL CONDITIONS	25 deg. C, 66%RH, 965 hPa	PHASE	Line (L)
TESTED BY	Wen Yu		

No	Freq. [MHz]	Corr. Factor (dB)	Reading Value		Emission Level		Limit		Margin	
			[dB (uV)]		[dB (uV)]		[dB (uV)]		(dB)	
			Q.P.	AV.	Q.P.	AV.	Q.P.	AV.	Q.P.	AV.
1	0.150	0.17	48.12	-	48.29	-	66.00	56.00	-17.71	-
2	0.177	0.18	43.24	-	43.42	-	64.61	54.61	-21.19	-
3	0.502	0.23	33.59	-	33.82	-	56.00	46.00	-22.18	-
4	4.402	0.65	32.74	-	33.39	-	56.00	46.00	-22.61	-
5	6.180	0.76	36.88	-	37.64	-	60.00	50.00	-22.36	-
6	15.492	1.19	39.13	-	40.32	-	60.00	50.00	-19.68	-

- REMARKS:**
1. Q.P. and AV. are abbreviations of quasi-peak and average individually.
 2. "-": The Quasi-peak reading value also meets average limit and measurement with the average detector is unnecessary.
 3. The emission levels of other frequencies were very low against the limit.
 4. Margin value = Emission level - Limit value
 5. Correction factor = Insertion loss + Cable loss
 6. Emission Level = Correction Factor + Reading Value.

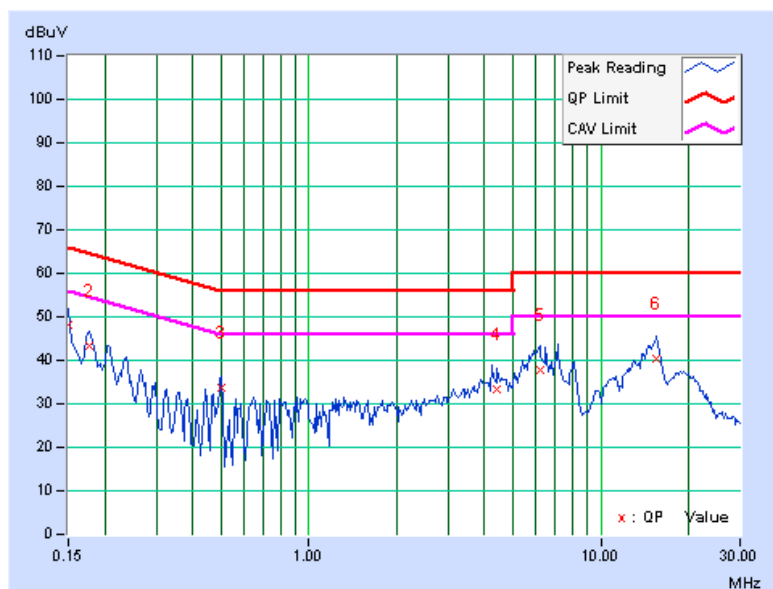



A D T

INPUT POWER (SYSTEM)	120Vac, 60 Hz	6dB BANDWIDTH	9 kHz
ENVIRONMENTAL CONDITIONS	25 deg. C, 66%RH, 965 hPa	PHASE	Neutral (N)
TESTED BY	Frank Liu		

No	Freq. [MHz]	Corr. Factor (dB)	Reading Value		Emission Level		Limit		Margin	
			[dB (uV)]		[dB (uV)]		[dB (uV)]		(dB)	
			Q.P.	AV.	Q.P.	AV.	Q.P.	AV.	Q.P.	AV.
1	0.150	0.10	48.01	-	48.11	-	66.00	56.00	-17.89	-
2	0.177	0.11	42.55	-	42.66	-	64.61	54.61	-21.95	-
3	0.502	0.17	33.27	-	33.44	-	56.00	46.00	-22.56	-
4	4.523	0.58	32.51	-	33.09	-	56.00	46.00	-22.91	-
5	6.199	0.66	36.84	-	37.50	-	60.00	50.00	-22.50	-
6	15.426	0.98	38.42	-	39.40	-	60.00	50.00	-20.60	-

- REMARKS:**
1. Q.P. and AV. are abbreviations of quasi-peak and average individually.
 2. "-": The Quasi-peak reading value also meets average limit and measurement with the average detector is unnecessary.
 3. The emission levels of other frequencies were very low against the limit.
 4. Margin value = Emission level - Limit value
 5. Correction factor = Insertion loss + Cable loss
 6. Emission Level = Correction Factor + Reading Value.

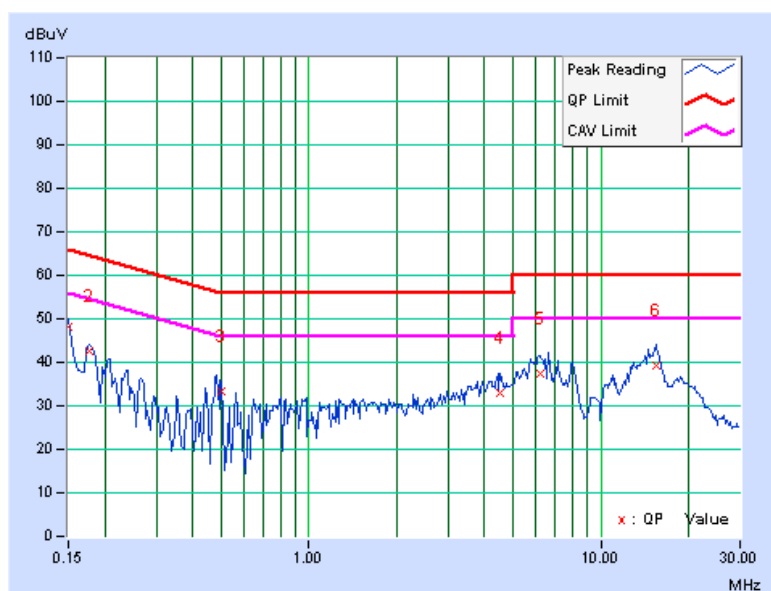



A D T

For Cradle (1 Slot) Mode

INPUT POWER (SYSTEM)	120Vac, 60 Hz	6DB BANDWIDTH	9 kHz
ENVIRONMENTAL CONDITIONS	25 deg. C, 66%RH, 965 hPa	PHASE	Line (L)
TESTED BY	Frank Liu		

No	Freq. [MHz]	Corr. Factor (dB)	Reading Value		Emission Level		Limit		Margin	
			[dB (uV)]		[dB (uV)]		[dB (uV)]		(dB)	
			Q.P.	AV.	Q.P.	AV.	Q.P.	AV.	Q.P.	AV.
1	0.205	0.18	45.67	-	45.85	-	63.42	53.42	-17.57	-
2	0.306	0.19	36.57	-	36.76	-	60.07	50.07	-23.32	-
3	0.412	0.19	37.67	-	37.86	-	57.61	47.61	-19.75	-
4	0.615	0.28	38.24	-	38.52	-	56.00	46.00	-17.48	-
5	0.884	0.39	33.67	-	34.06	-	56.00	46.00	-21.94	-
6	1.300	0.47	33.42	-	33.89	-	56.00	46.00	-22.11	-

- REMARKS:**
1. Q.P. and AV. are abbreviations of quasi-peak and average individually.
 2. "-": The Quasi-peak reading value also meets average limit and measurement with the average detector is unnecessary.
 3. The emission levels of other frequencies were very low against the limit.
 4. Margin value = Emission level - Limit value
 5. Correction factor = Insertion loss + Cable loss
 6. Emission Level = Correction Factor + Reading Value.

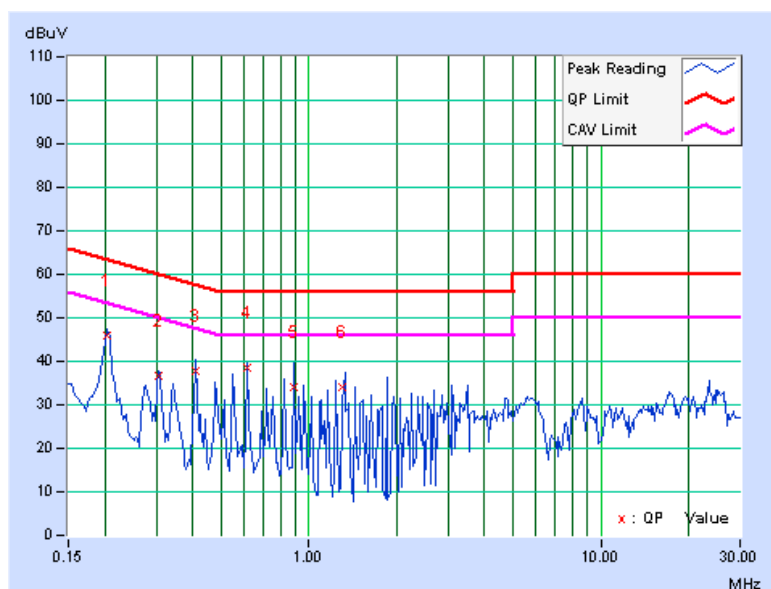



A D T

INPUT POWER (SYSTEM)	120Vac, 60 Hz	6dB BANDWIDTH	9 kHz
ENVIRONMENTAL CONDITIONS	25 deg. C, 66%RH, 965 hPa	PHASE	Neutral (N)
TESTED BY	Frank Liu		

No	Freq. [MHz]	Corr. Factor (dB)	Reading Value		Emission Level		Limit		Margin	
			[dB (uV)]		[dB (uV)]		[dB (uV)]		(dB)	
			Q.P.	AV.	Q.P.	AV.	Q.P.	AV.	Q.P.	AV.
1	0.205	0.11	45.64	-	45.75	-	63.42	53.42	-17.67	-
2	0.306	0.12	36.84	-	36.96	-	60.07	50.07	-23.11	-
3	0.408	0.13	32.65	-	32.78	-	57.69	47.69	-24.91	-
4	0.615	0.21	31.96	-	32.17	-	56.00	46.00	-23.83	-
5	0.822	0.28	34.84	-	35.12	-	56.00	46.00	-20.88	-
6	0.924	0.32	29.66	-	29.98	-	56.00	46.00	-26.02	-

- REMARKS:**
1. Q.P. and AV. are abbreviations of quasi-peak and average individually.
 2. "-": The Quasi-peak reading value also meets average limit and measurement with the average detector is unnecessary.
 3. The emission levels of other frequencies were very low against the limit.
 4. Margin value = Emission level - Limit value
 5. Correction factor = Insertion loss + Cable loss
 6. Emission Level = Correction Factor + Reading Value.

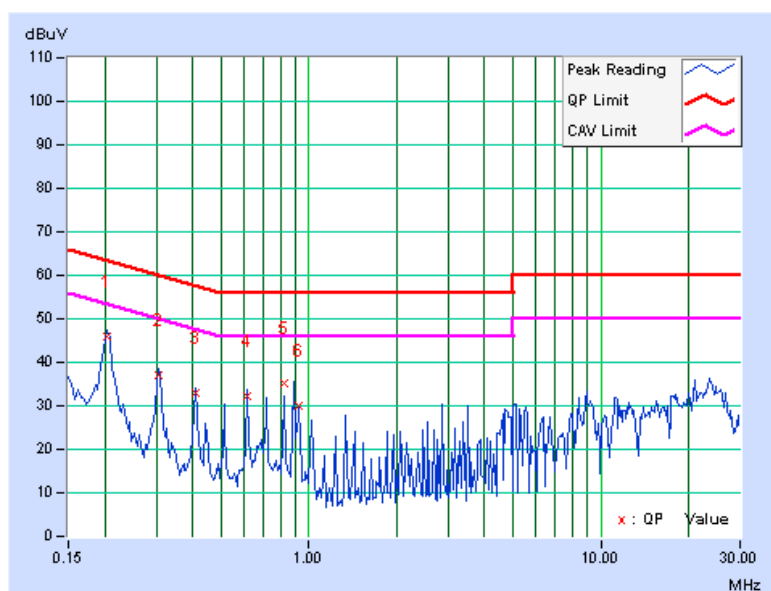



A D T

For Cradle (4 Slot) Mode

INPUT POWER (SYSTEM)	120Vac, 60 Hz	6DB BANDWIDTH	9 kHz
ENVIRONMENTAL CONDITIONS	25 deg. C, 66%RH, 965 hPa	PHASE	Line (L)
TESTED BY	Frank Liu		

No	Freq. [MHz]	Corr. Factor (dB)	Reading Value		Emission Level		Limit		Margin	
			[dB (uV)]		[dB (uV)]		[dB (uV)]		(dB)	
			Q.P.	AV.	Q.P.	AV.	Q.P.	AV.	Q.P.	AV.
1	0.150	0.17	50.44	-	50.61	-	66.00	56.00	-15.39	-
2	0.162	0.17	51.99	-	52.16	-	65.38	55.38	-13.21	-
3	0.173	0.17	43.34	-	43.51	-	64.79	54.79	-21.28	-
4	0.227	0.18	39.26	-	39.44	-	62.56	52.56	-23.12	-
5	0.295	0.18	32.27	-	32.45	-	60.40	50.40	-27.94	-
6	0.748	0.33	27.29	-	27.62	-	56.00	46.00	-28.38	-

- REMARKS:**
1. Q.P. and AV. are abbreviations of quasi-peak and average individually.
 2. "-": The Quasi-peak reading value also meets average limit and measurement with the average detector is unnecessary.
 3. The emission levels of other frequencies were very low against the limit.
 4. Margin value = Emission level - Limit value
 5. Correction factor = Insertion loss + Cable loss
 6. Emission Level = Correction Factor + Reading Value.

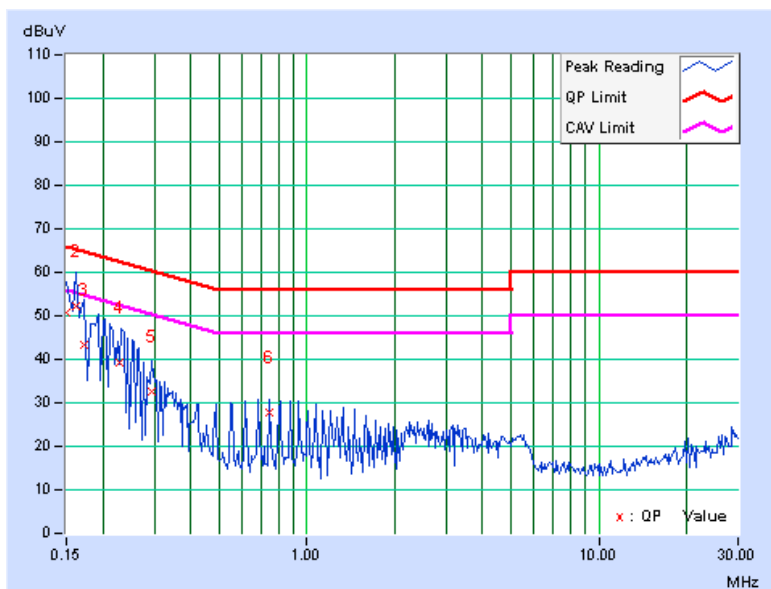



A D T

INPUT POWER (SYSTEM)	120Vac, 60 Hz	6dB BANDWIDTH	9 kHz
ENVIRONMENTAL CONDITIONS	25 deg. C, 66%RH, 965 hPa	PHASE	Neutral (N)
TESTED BY	Frank Liu		

No	Freq. [MHz]	Corr. Factor (dB)	Reading Value		Emission Level		Limit		Margin	
			[dB (uV)]		[dB (uV)]		[dB (uV)]		(dB)	
			Q.P.	AV.	Q.P.	AV.	Q.P.	AV.	Q.P.	AV.
1	0.159	0.10	51.84	-	51.94	-	65.51	55.51	-13.57	-
2	0.227	0.11	40.73	-	40.84	-	62.56	52.56	-21.72	-
3	0.228	0.11	40.26	-	40.37	-	62.52	52.52	-22.15	-
4	0.291	0.12	35.74	-	35.86	-	60.51	50.51	-24.65	-
5	0.619	0.21	27.83	-	28.04	-	56.00	46.00	-27.96	-
6	0.748	0.26	28.66	-	28.92	-	56.00	46.00	-27.08	-

- REMARKS:**
1. Q.P. and AV. are abbreviations of quasi-peak and average individually.
 2. "-": The Quasi-peak reading value also meets average limit and measurement with the average detector is unnecessary.
 3. The emission levels of other frequencies were very low against the limit.
 4. Margin value = Emission level - Limit value
 5. Correction factor = Insertion loss + Cable loss
 6. Emission Level = Correction Factor + Reading Value.

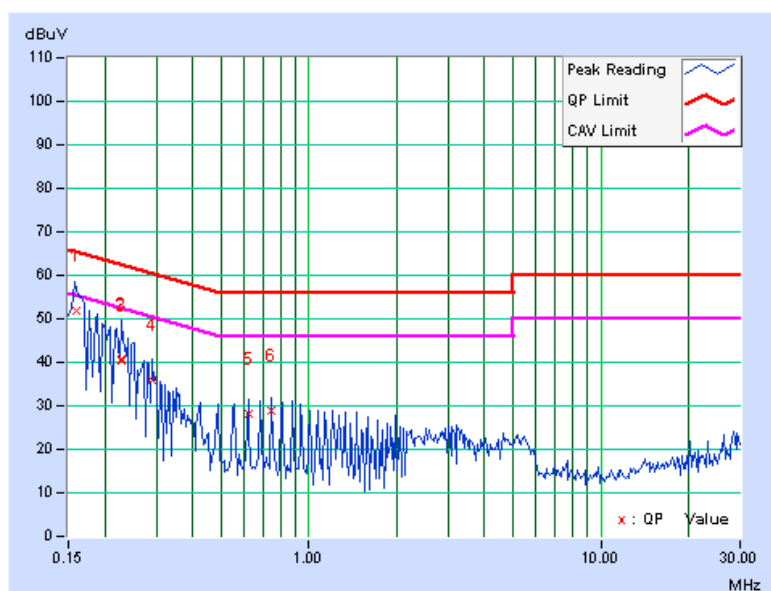

4.2 NUMBER OF HOPPING FREQUENCY USED

4.2.1 LIMIT OF HOPPING FREQUENCY USED

At least 15 hopping frequencies, and should be equally spaced.

4.2.2 TEST INSTRUMENTS

DESCRIPTION & MANUFACTURER	MODEL NO.	SERIAL NO.	CALIBRATED DATE	CALIBRATED UNTIL
R&S SPECTRUM ANALYZER	FSP40	100037	Aug. 09, 2009	Aug. 08, 2010

NOTE:

1. The calibration interval of the above test instruments is 12 months and the calibrations are traceable to NML/ROC and NIST/USA.

4.2.3 TEST PROCEDURES

1. Check the calibration of the measuring instrument (SA) using either an internal calibrator or a known signal from an external generator.
2. Turn on the EUT and connect its antenna terminal to measurement via a low loss cable. Then set it to any one measured frequency within its operating range and make sure the instrument is operated in its linear range.
3. Set the SA on MaxHold Mode, and then keep the EUT in hopping mode. Record all the signals from each channel until each one has been recorded.
4. Set the SA on View mode and then plot the result on SA screen.
5. Repeat above procedures until all frequencies measured were complete.

4.2.4 DEVIATION FROM TEST STANDARD

No deviation

4.2.5 TEST SETUP



4.2.6 TEST RESULTS

There are 79 hopping frequencies in the hopping mode. Please refer to next pages for the test result. On the plots, it shows that the hopping frequencies are equally spaced.



A D T

For GFSK :

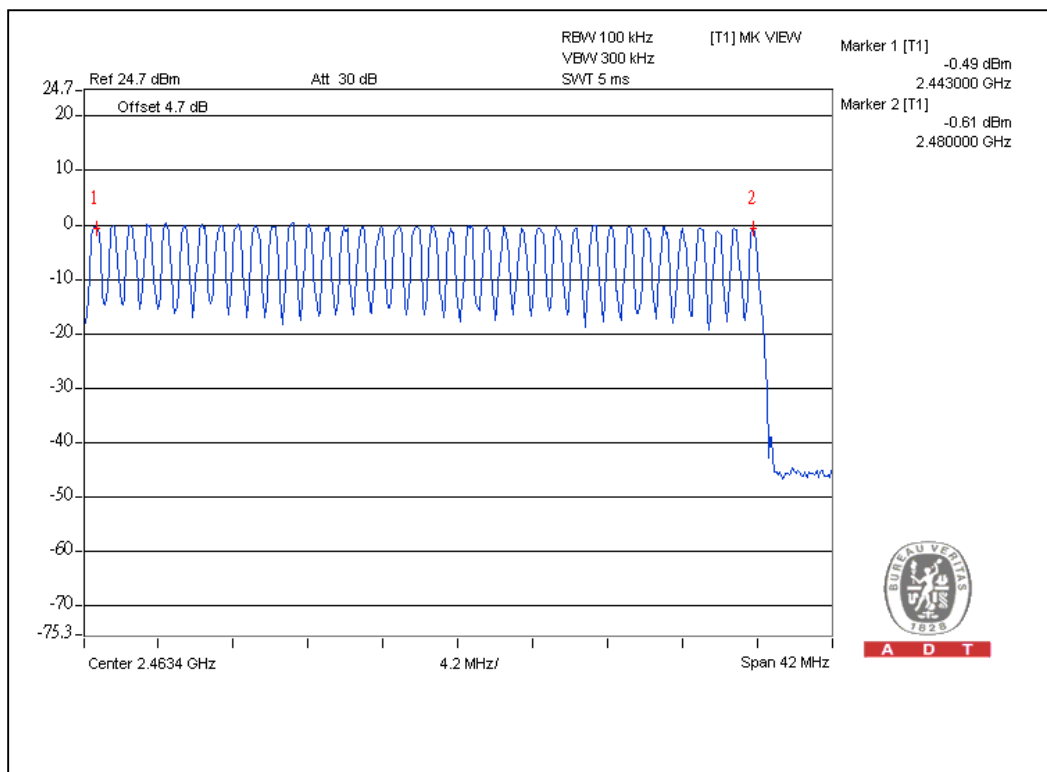
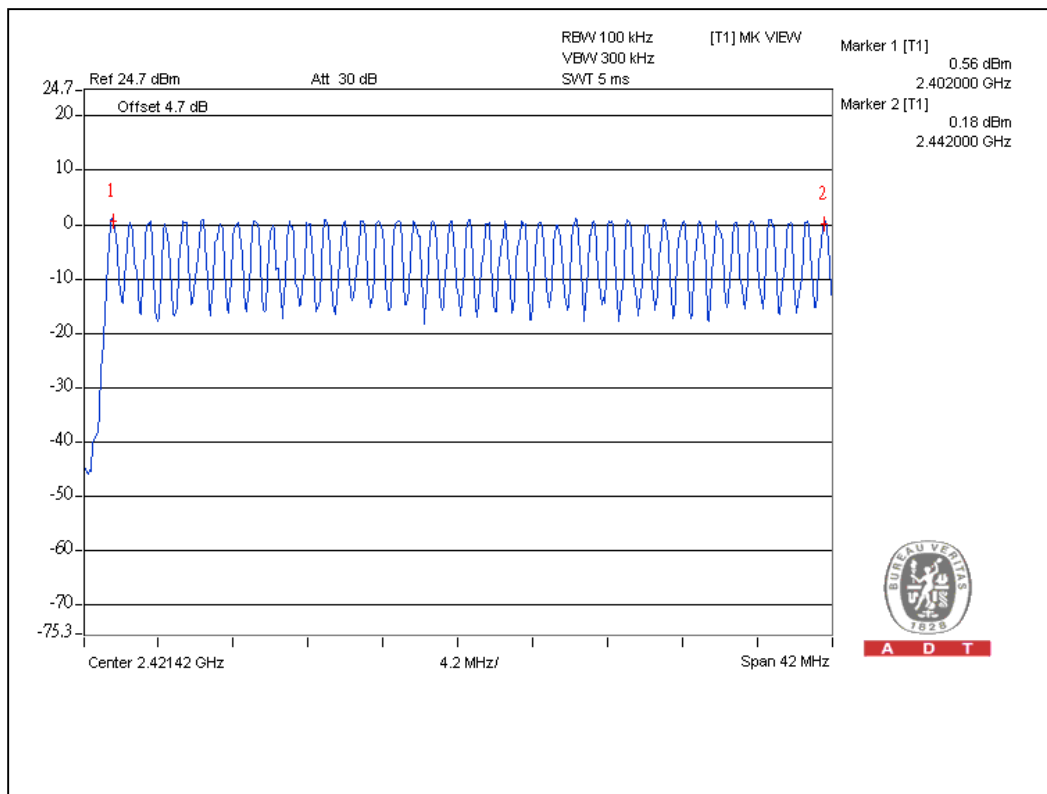



A D T

For 8DPSK :

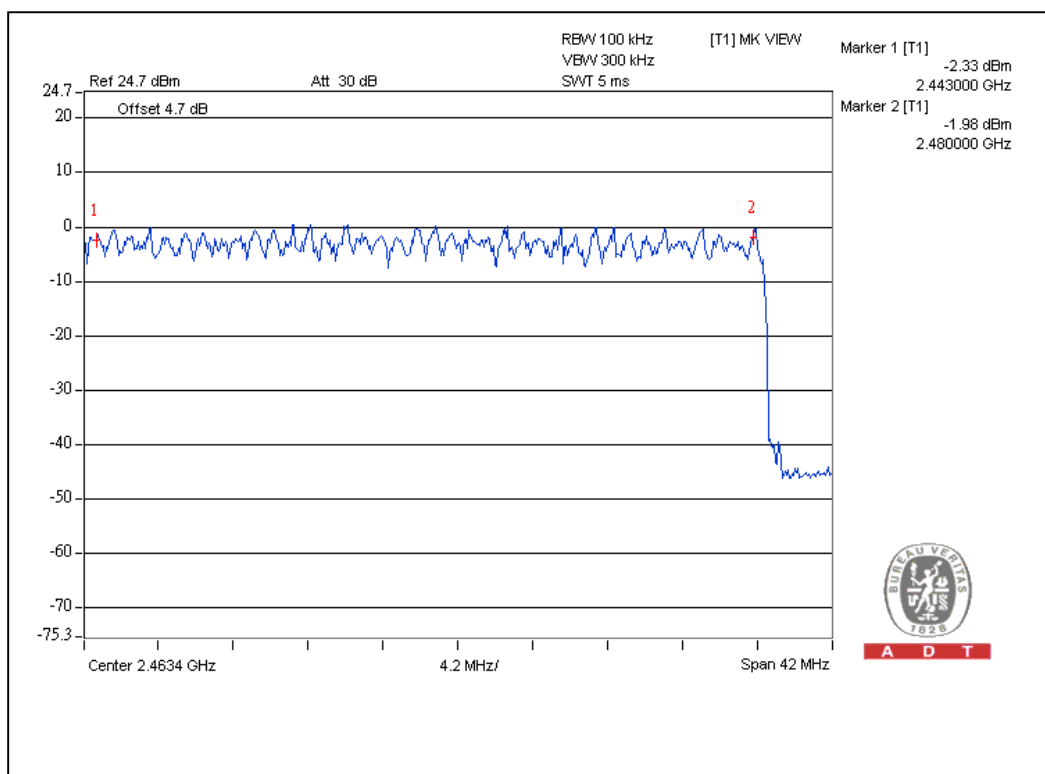
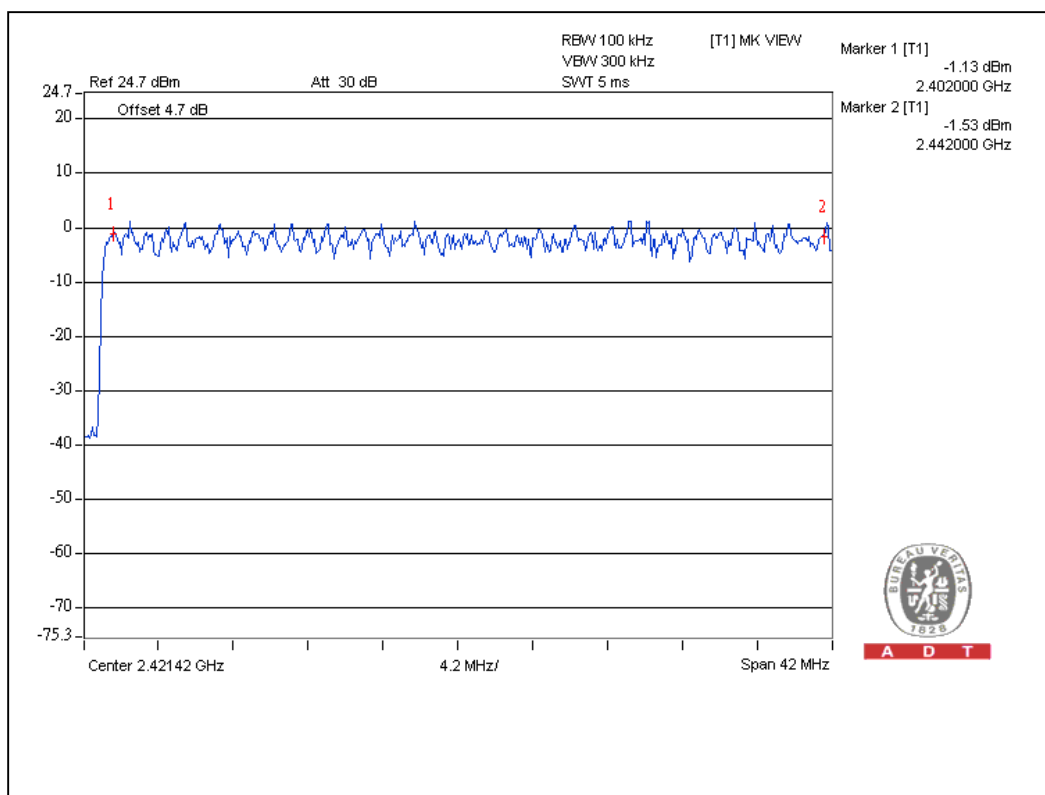



A D T

For $\pi/4$ -DQPSK :

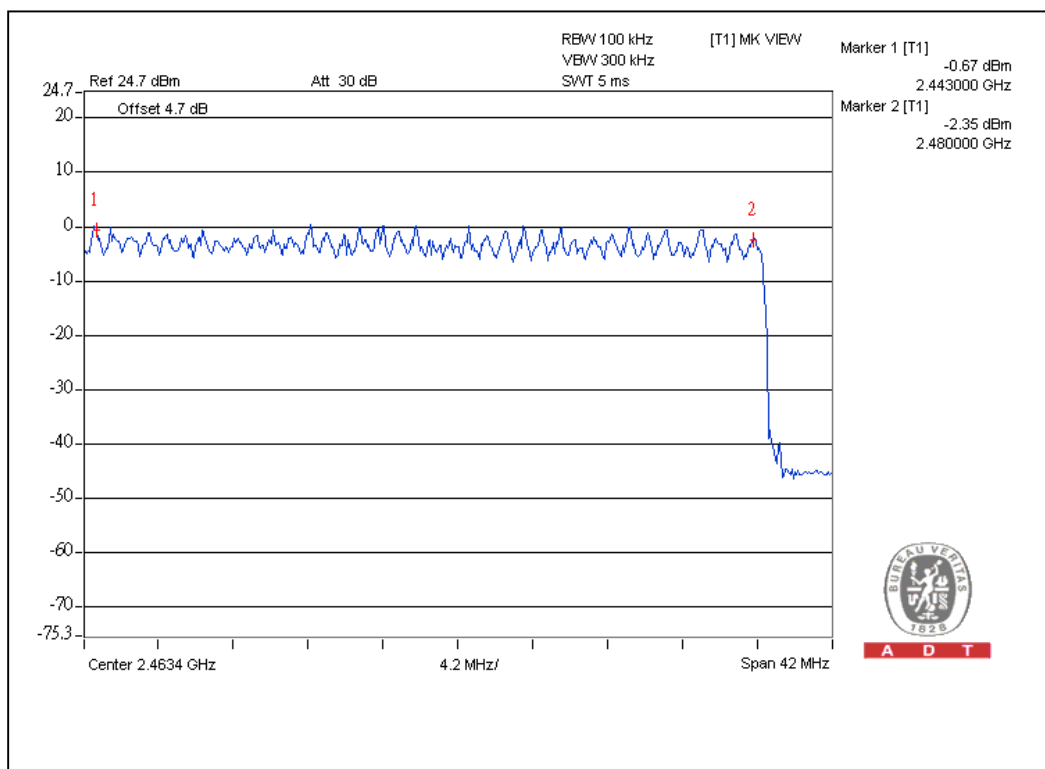
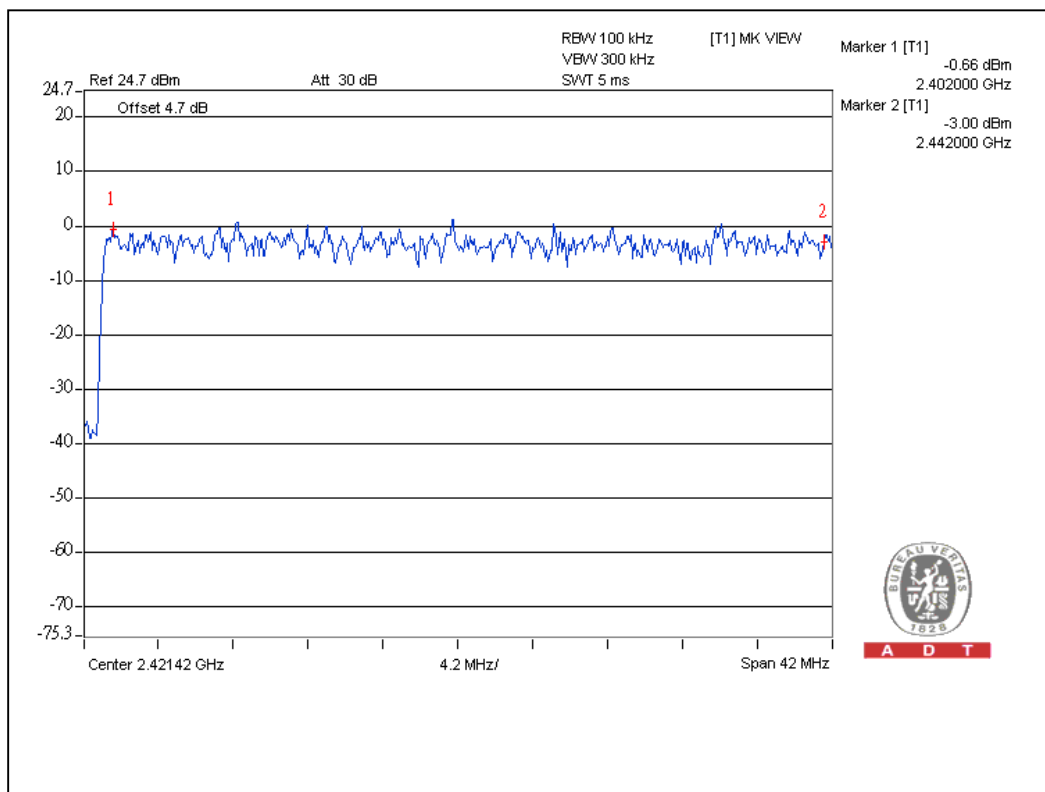

4.3 DWELL TIME ON EACH CHANNEL

4.3.1 LIMIT OF DWELL TIME USED

For FHSS, the average time of occupancy on any frequency shall not be greater than 0.4 seconds within a 31.6 second period. For hybrid systems, the average time of occupancy on any frequency should not exceed 0.4 seconds within a time period in seconds equal to the number of hopping frequencies employed multiplied by 0.4.

4.3.2 TEST INSTRUMENTS

DESCRIPTION & MANUFACTURER	MODEL NO.	SERIAL NO.	CALIBRATED DATE	CALIBRATED UNTIL
R&S SPECTRUM ANALYZER	FSP40	100037	Aug. 09, 2009	Aug. 08, 2010

NOTE:

1. The calibration interval of the above test instruments is 12 months and the calibrations are traceable to NML/ROC and NIST/USA.

4.3.3 TEST PROCEDURES

1. Check the calibration of the measuring instrument (SA) using either an internal calibrator or a known signal from an external generator.
2. Turn on the EUT and connect its antenna terminal to measurement via a low loss cable. Then set it to any one measured frequency within its operating range and make sure the instrument is operated in its linear range.
3. Adjust the center frequency of SA on any frequency be measured and set SA to zero span mode. And then, set RBW and VBW of spectrum analyzer to proper value.
4. Measure the time duration of one transmission on the measured frequency. And then plot the result with time difference of this time duration.
5. Repeat above procedures until all frequencies measured were complete.

4.3.4 DEVIATION FROM TEST STANDARD

No deviation

4.3.5 TEST SETUP

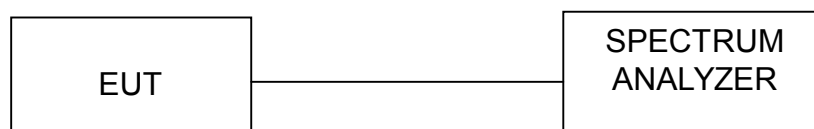

4.3.6 TEST RESULTS

Mode	Number of transmission in a 31.6 (79Hopping*0.4)	Length of transmission time (msec)	Result (msec)	Limit (msec)
DH1	51 (times / 5 sec) *6.32=322.32 times	0.6	193.4	400
DH3	22 (times / 5 sec) *6.32=139.04 times	1.776	246.9	400
DH5	17 (times / 5 sec) *6.32=107.44 times	3.05	327.7	400

Test plots of the transmitting time slot are shown on next three pages.



A D T

DH1

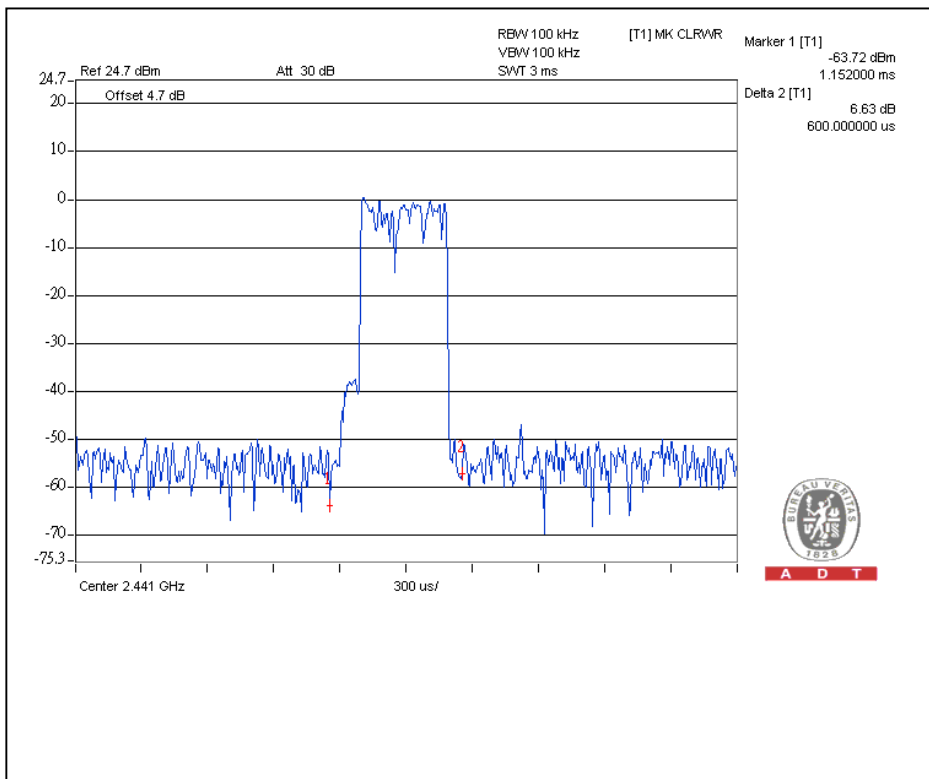
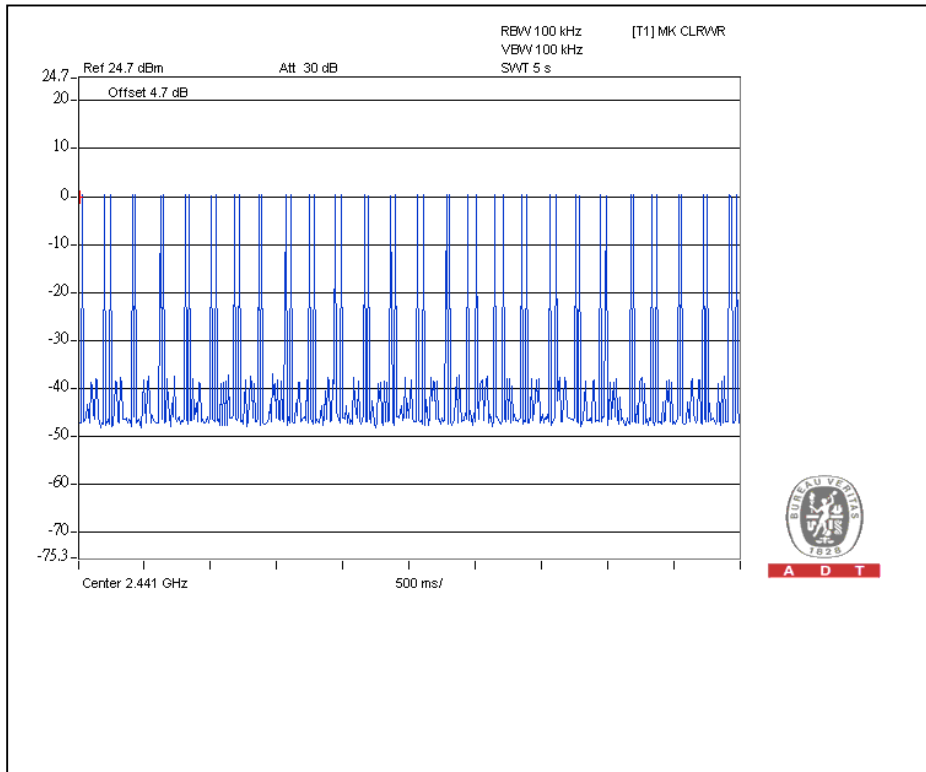



A D T

DH3

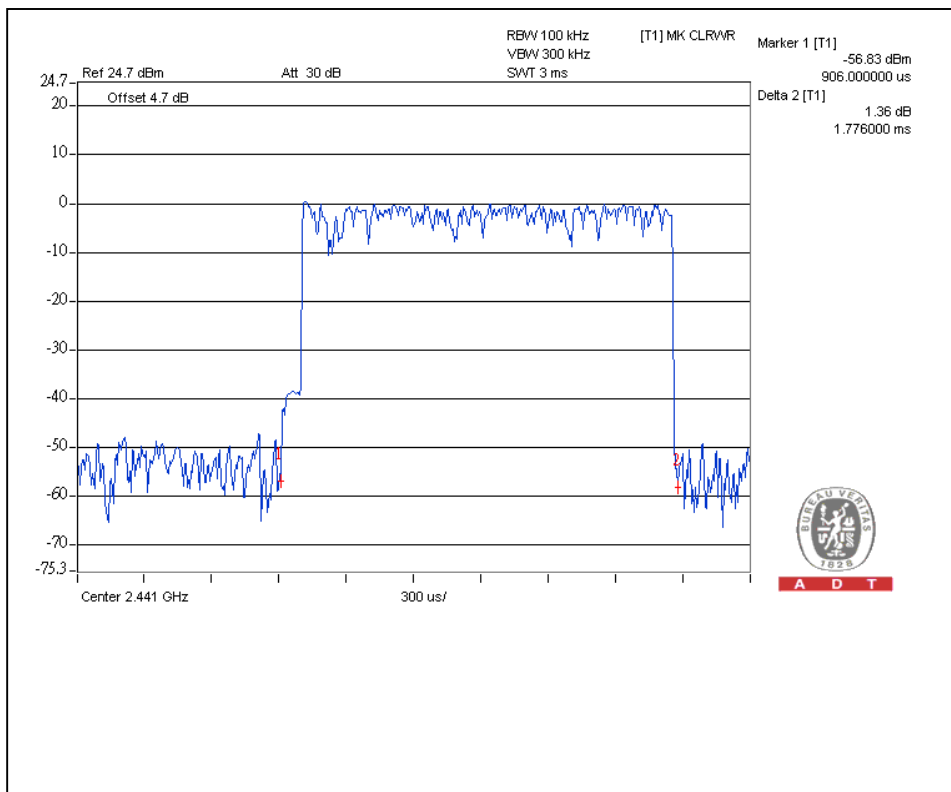
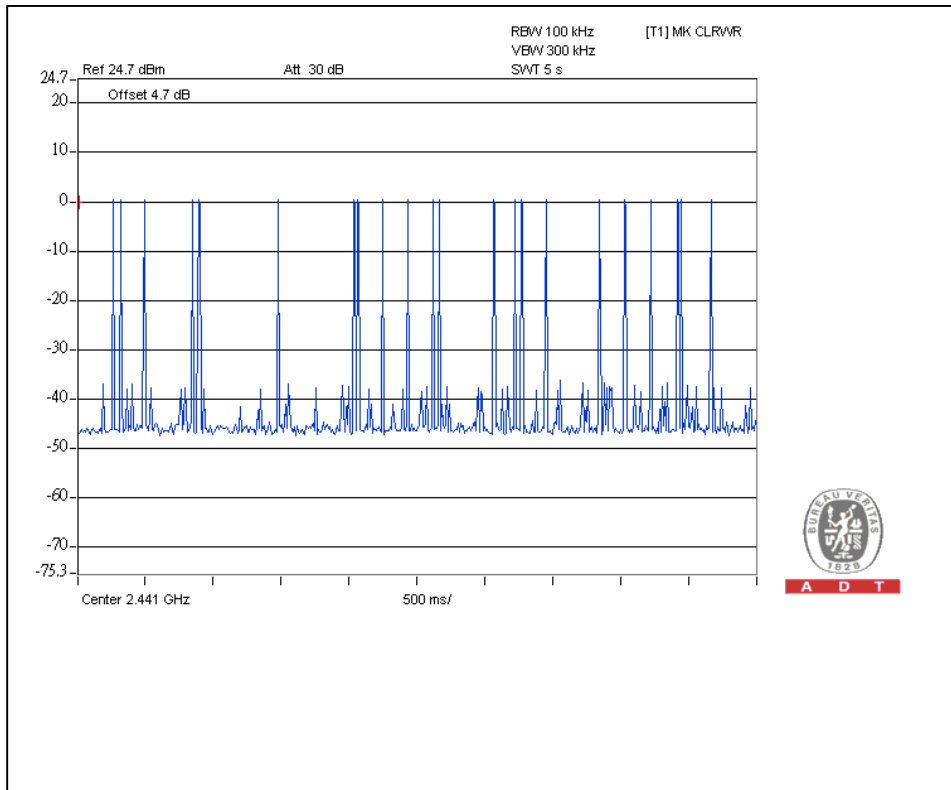

4.4 CHANNEL BANDWIDTH

4.4.1 LIMITS OF CHANNEL BANDWIDTH

For frequency hopping system operating in the 2400-2483.5MHz, If the two-thirds 20dB bandwidth of hopping channel is greater than 25kHz, two-thirds 20dB bandwidth of hopping channel shall be a minimum limit for the hopping channel separation.

4.4.2 TEST INSTRUMENTS

DESCRIPTION & MANUFACTURER	MODEL NO.	SERIAL NO.	CALIBRATED DATE	CALIBRATED UNTIL
R&S SPECTRUM ANALYZER	FSP40	100037	Aug. 09, 2009	Aug. 08, 2010

NOTE:

- 1.The calibration interval of the above test instruments is 12 months and the calibrations are traceable to NML/ROC and NIST/USA.

4.4.3 TEST PROCEDURE

1. Check the calibration of the measuring instrument using either an internal calibrator or a known signal from an external generator.
2. Turn on the EUT and connect it to measurement instrument. Then set it to any one convenient frequency within its operating range. Set a reference level on the measuring instrument equal to the highest peak value.
3. Measure the frequency difference of two frequencies that were attenuated 20dB from the reference level. Record the frequency difference as the emission bandwidth.
4. Repeat above procedures until all frequencies measured were complete.

4.4.4 DEVIATION FROM TEST STANDARD

No deviation

4.4.5 TEST SETUP

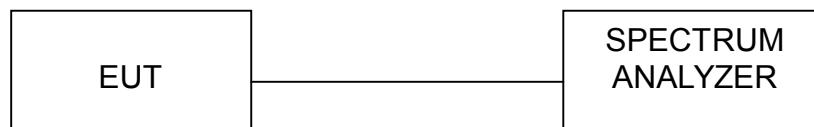

4.4.6 EUT OPERATING CONDITION

The software provided by client enabled the EUT to transmit and receive data at lowest, middle and highest channel frequencies individually.



A D T

4.4.7 TEST RESULTS

MODULATION TYPE	GFSK	INPUT POWER (SYSTEM)	120Vac, 60 Hz
ENVIRONMENTAL CONDITIONS	25deg. C, 60%RH, 965 hPa	TESTED BY	Wen Yu

CHANNEL	CHANNEL FREQUENCY (MHz)	20dB BANDWIDTH (kHz)
0	2402	968
39	2441	1016
78	2480	1003

Channel 0

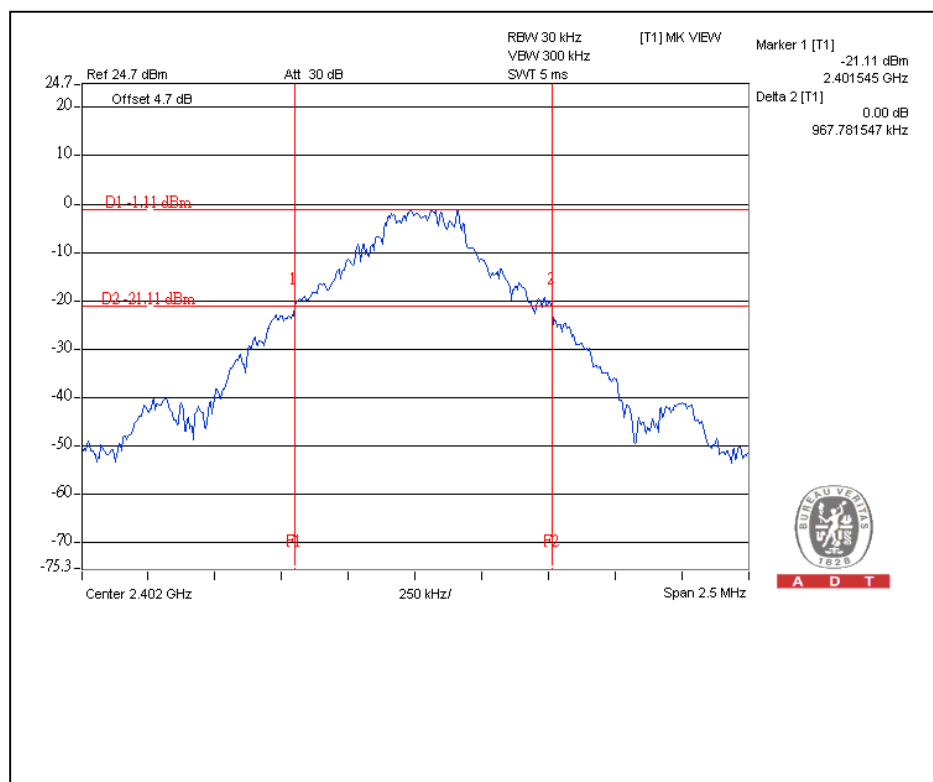



A D T

Channel 39

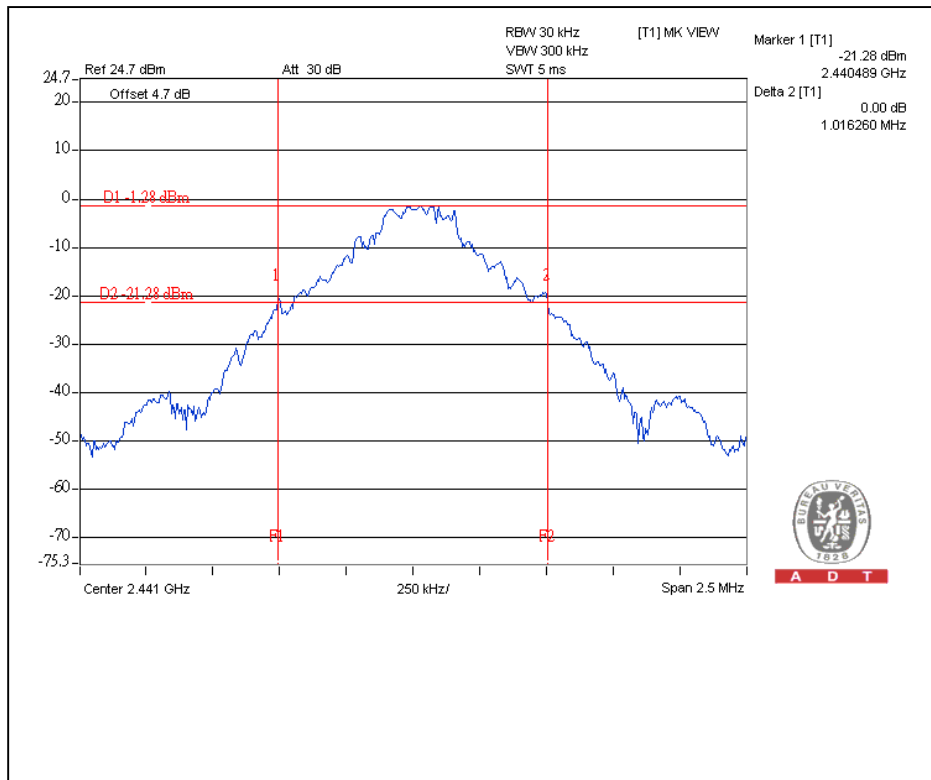

Channel 78

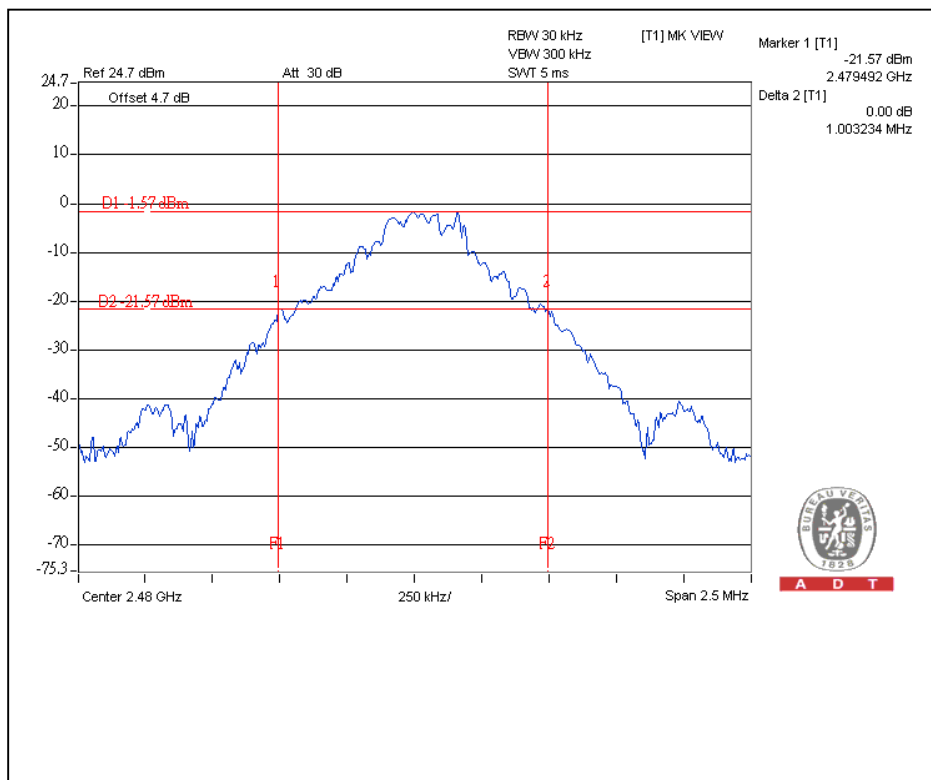



A D T

MODULATION TYPE	8DPSK	INPUT POWER (SYSTEM)	120Vac, 60 Hz
ENVIRONMENTAL CONDITIONS	25deg. C, 60%RH, 965 hPa	TESTED BY	Wen Yu

CHANNEL	CHANNEL FREQUENCY (MHz)	20dB BANDWIDTH (kHz)
0	2402	1320
39	2441	1300
78	2480	1311

Channel 0

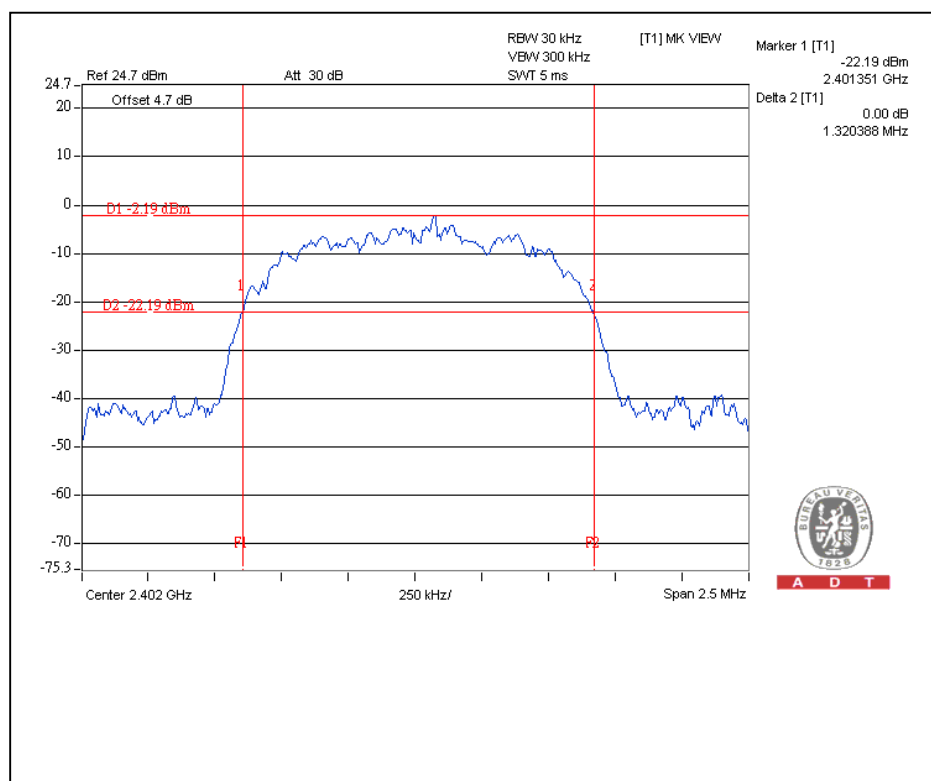



A D T

Channel 39

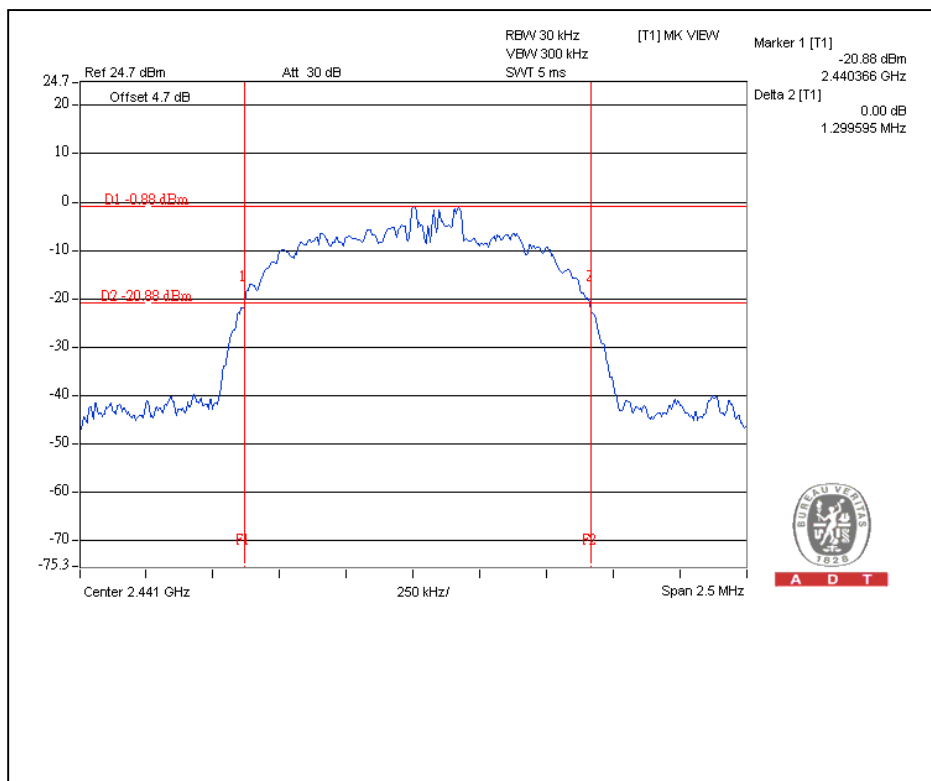

Channel 78

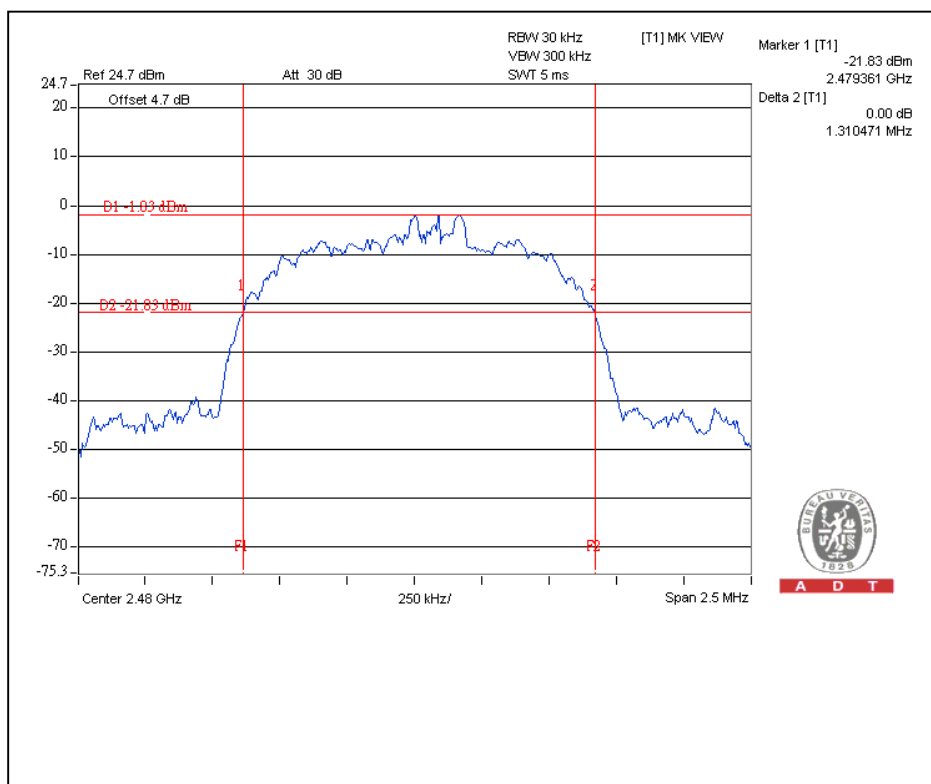



A D T

MODULATION TYPE	$\pi/4$ -DQPSK	INPUT POWER (SYSTEM)	120Vac, 60 Hz
ENVIRONMENTAL CONDITIONS	25deg. C, 60%RH, 965 hPa	TESTED BY	Wen Yu

CHANNEL	CHANNEL FREQUENCY (MHz)	20dB BANDWIDTH (kHz)
0	2402	1316
39	2441	1313
78	2480	1322

Channel 0

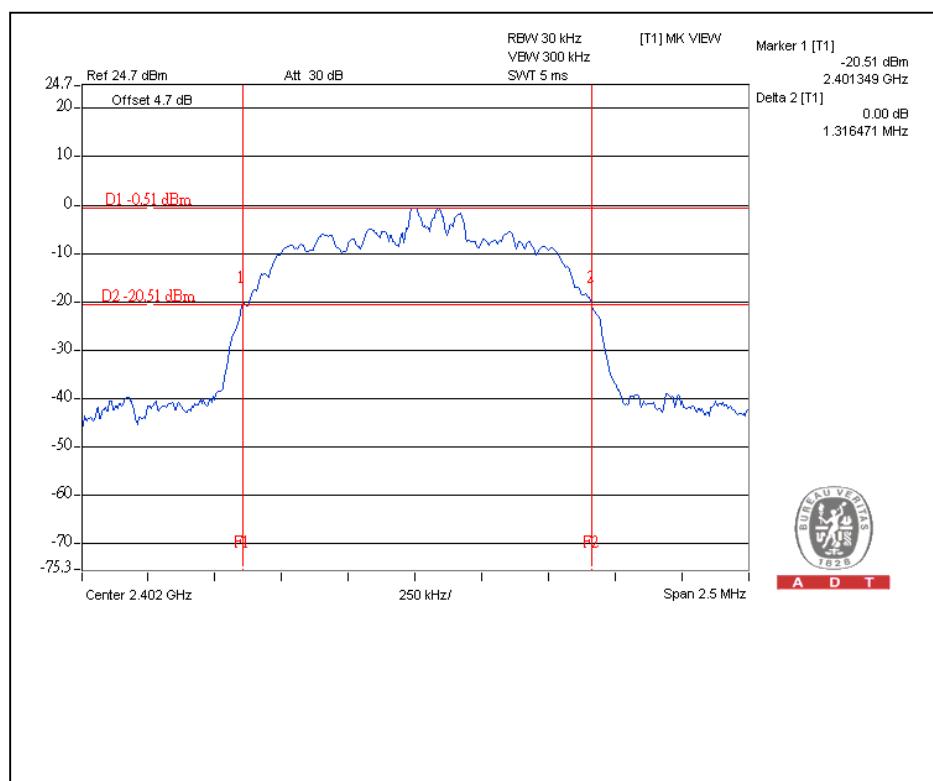



A D T

Channel 39

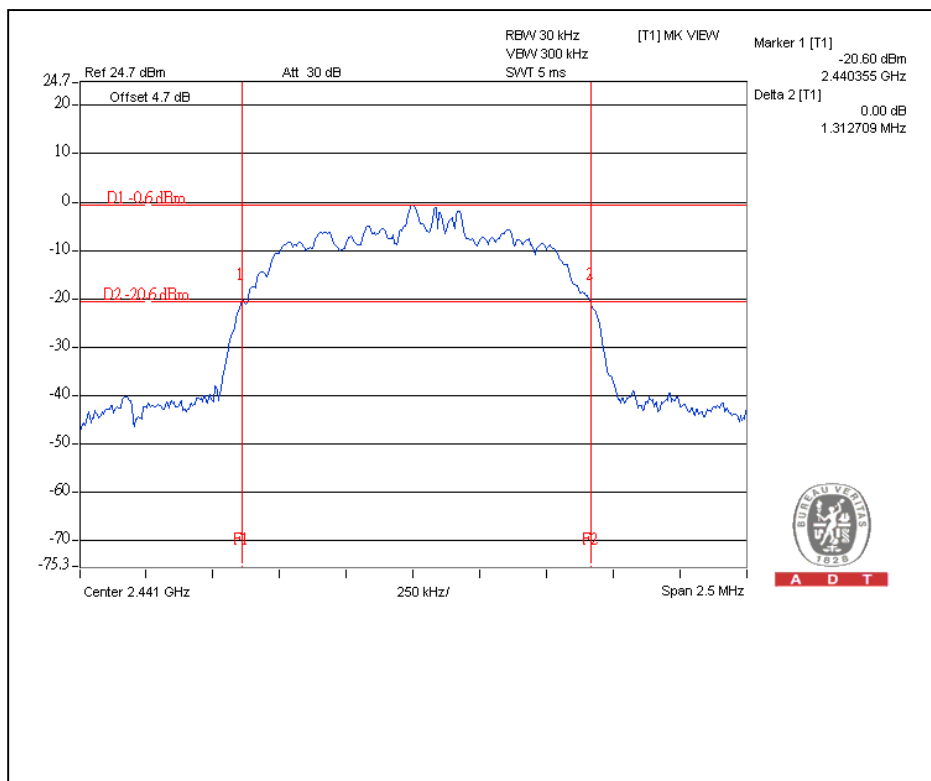

Channel 78

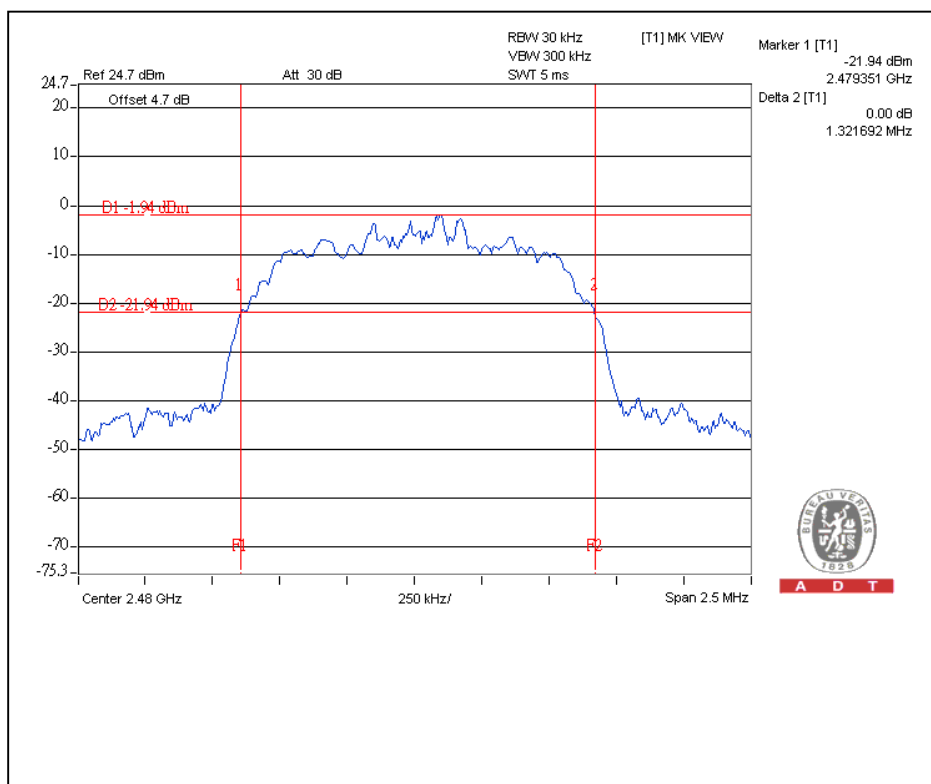



4.5 HOPPING CHANNEL SEPARATION

4.5.1 LIMIT OF HOPPING CHANNEL SEPARATION

At least 25 kHz or two-thirds of 20dB hopping channel bandwidth (whichever is greater).

4.5.2 TEST INSTRUMENTS

DESCRIPTION & MANUFACTURER	MODEL NO.	SERIAL NO.	CALIBRATED DATE	CALIBRATED UNTIL
R&S SPECTRUM ANALYZER	FSP40	100037	Aug. 09, 2009	Aug. 08, 2010

NOTE:

1. The calibration interval of the above test instruments is 12 months and the calibrations are traceable to NML/ROC and NIST/USA.

4.5.3 TEST PROCEDURES

1. Check the calibration of the measuring instrument using either an internal calibrator or a known signal from an external generator.
2. Turn on the EUT and connect it to measurement instrument. Then set it to any one convenient frequency within its operating range.
3. By using the MaxHold function record the separation of two adjacent channels.
4. Measure the frequency difference of these two adjacent channels by SA MARK function. And then plot the result on SA screen.
5. Repeat above procedures until all frequencies measured were complete.

4.5.4 DEVIATION FROM TEST STANDARD

No deviation

4.5.5 TEST SETUP

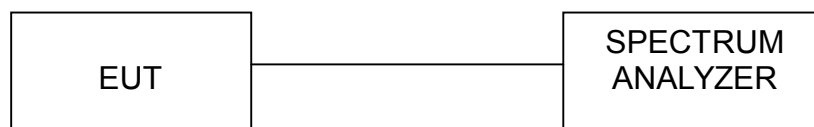



A D T

4.5.6 TEST RESULTS

MODULATION TYPE	GFSK	INPUT POWER (SYSTEM)	120Vac, 60 Hz
ENVIRONMENTAL CONDITIONS	25deg. C, 60%RH, 965 hPa	TESTED BY	Wen Yu

Channel	Frequency (MHz)	Adjacent Channel Separation (kHz)	Minimum Limit (kHz)	Pass / Fail
0	2402	1004	645	PASS
39	2441	1001	677	PASS
78	2480	1000	669	PASS

The minimum limit is two-thirds of 20dB bandwidth. Test results please refer to next two pages.

Channel 0

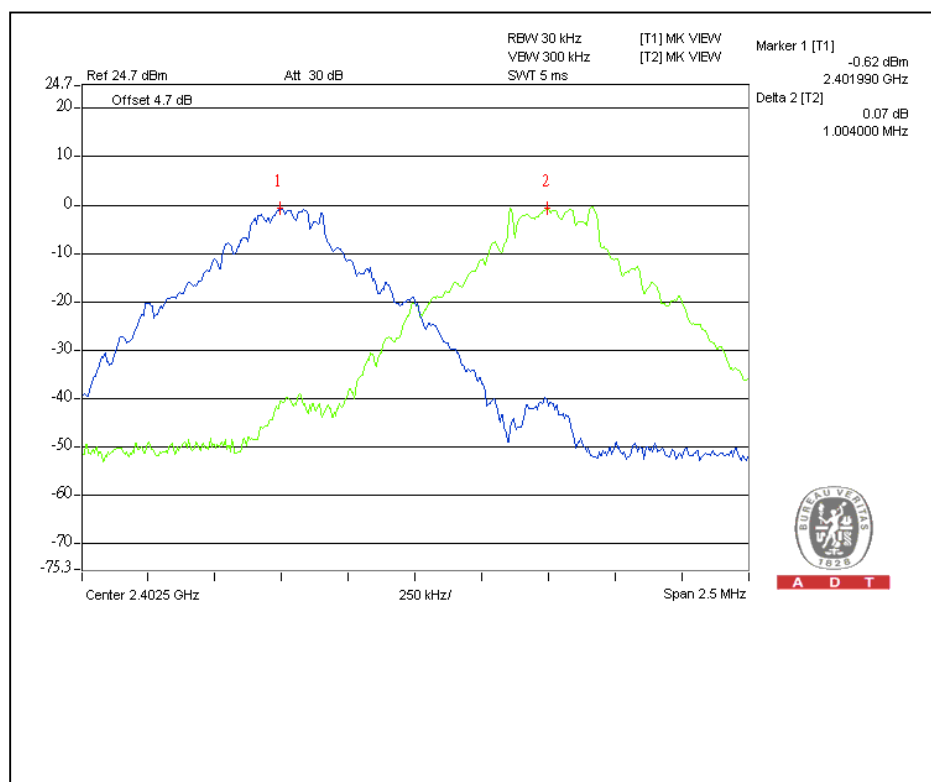



A D T

Channel 39

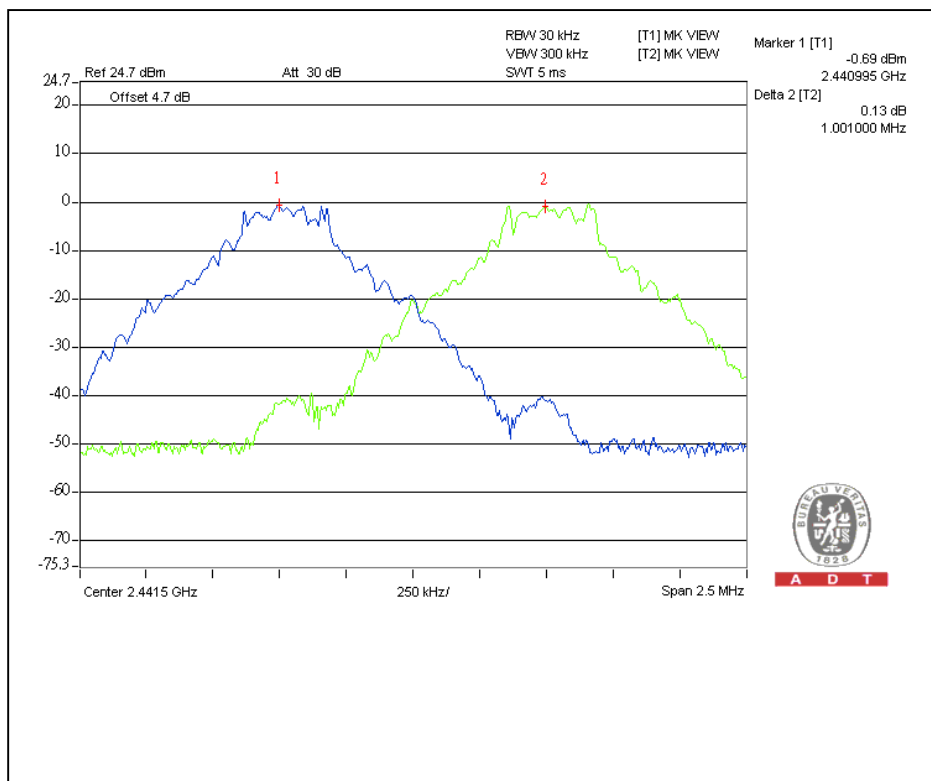

Channel 78

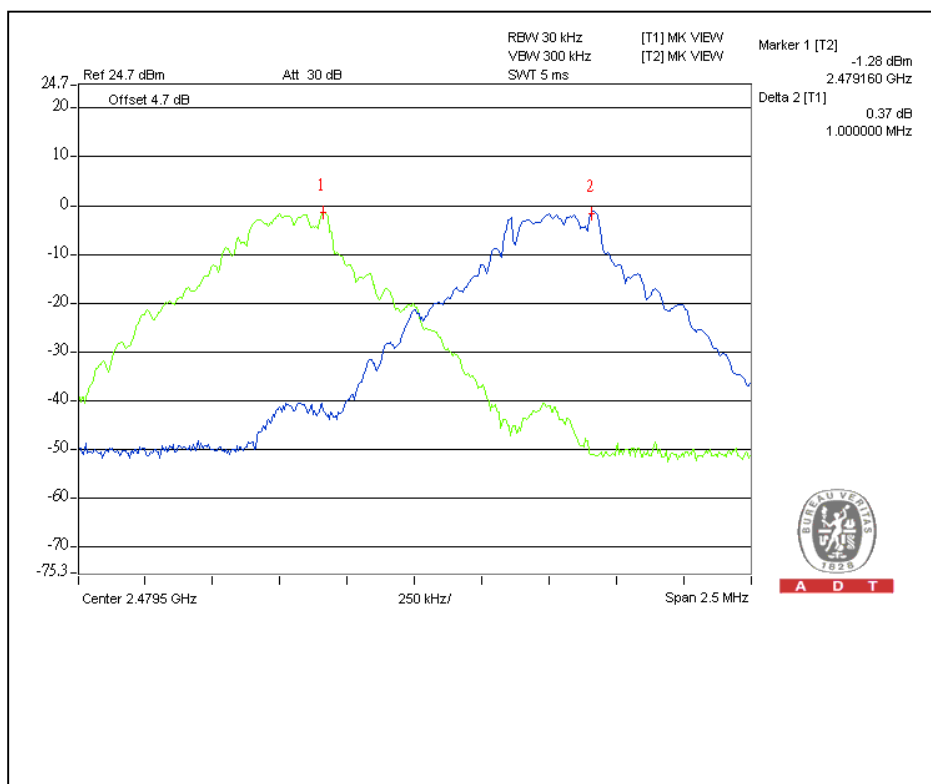



A D T

MODULATION TYPE	8DPSK	INPUT POWER (SYSTEM)	120Vac, 60 Hz
ENVIRONMENTAL CONDITIONS	25deg. C, 60%RH, 965 hPa	TESTED BY	Wen Yu

Channel	Frequency (MHz)	Adjacent Channel Separation (kHz)	Minimum Limit (kHz)	Pass / Fail
0	2402	1005	880	PASS
39	2441	1006	867	PASS
78	2480	1001	874	PASS

The minimum limit is two-thirds of 20dB bandwidth. Test results please refer to next two pages.

Channel 0

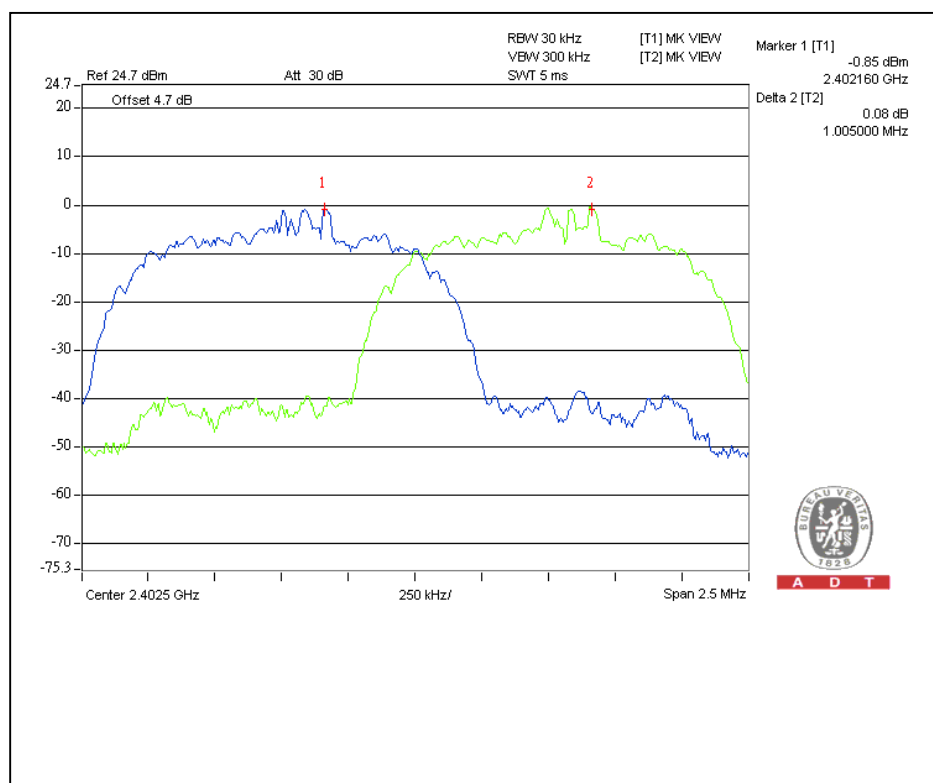



A D T

Channel 39

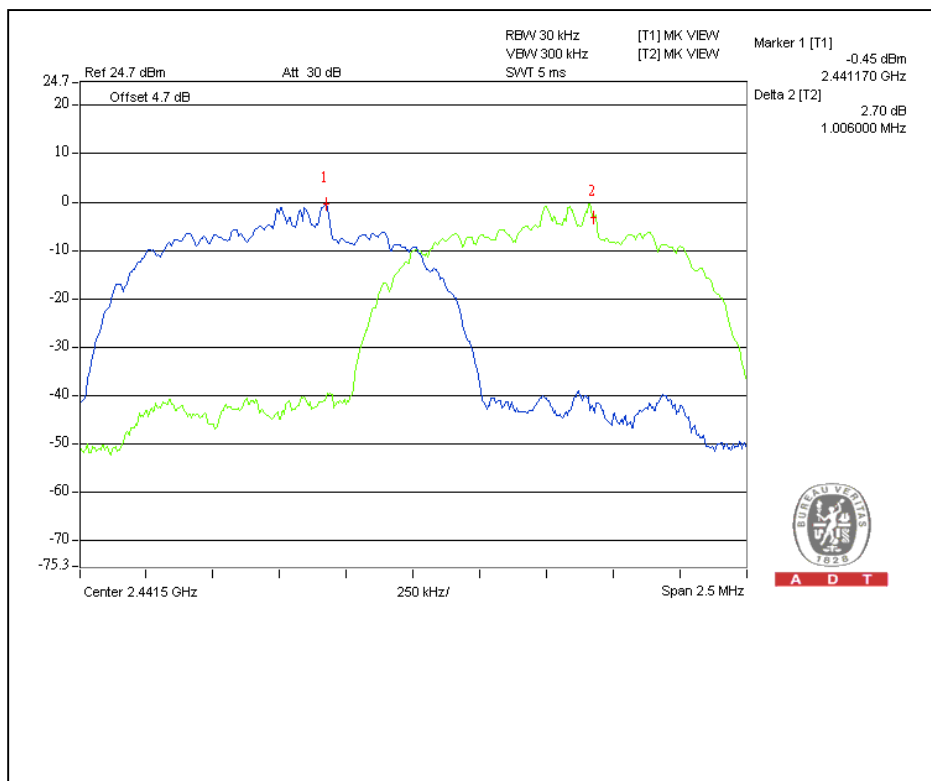

Channel 78

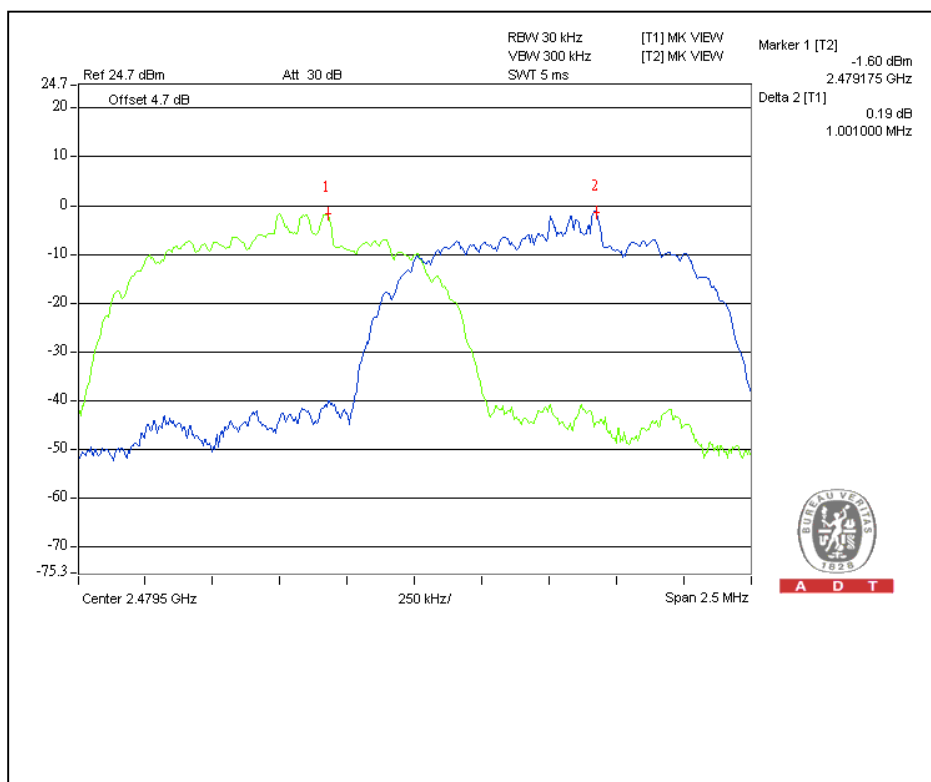



A D T

MODULATION TYPE	$\pi/4$ -DQPSK	INPUT POWER (SYSTEM)	120Vac, 60 Hz
ENVIRONMENTAL CONDITIONS	25deg. C, 60%RH, 965 hPa	TESTED BY	Wen Yu

Channel	Frequency (MHz)	Adjacent Channel Separation (kHz)	Minimum Limit (kHz)	Pass / Fail
0	2402	1001	877	PASS
39	2441	1004	875	PASS
78	2480	1005	881	PASS

The minimum limit is two-thirds of 20dB bandwidth. Test results please refer to next two pages.

Channel 0

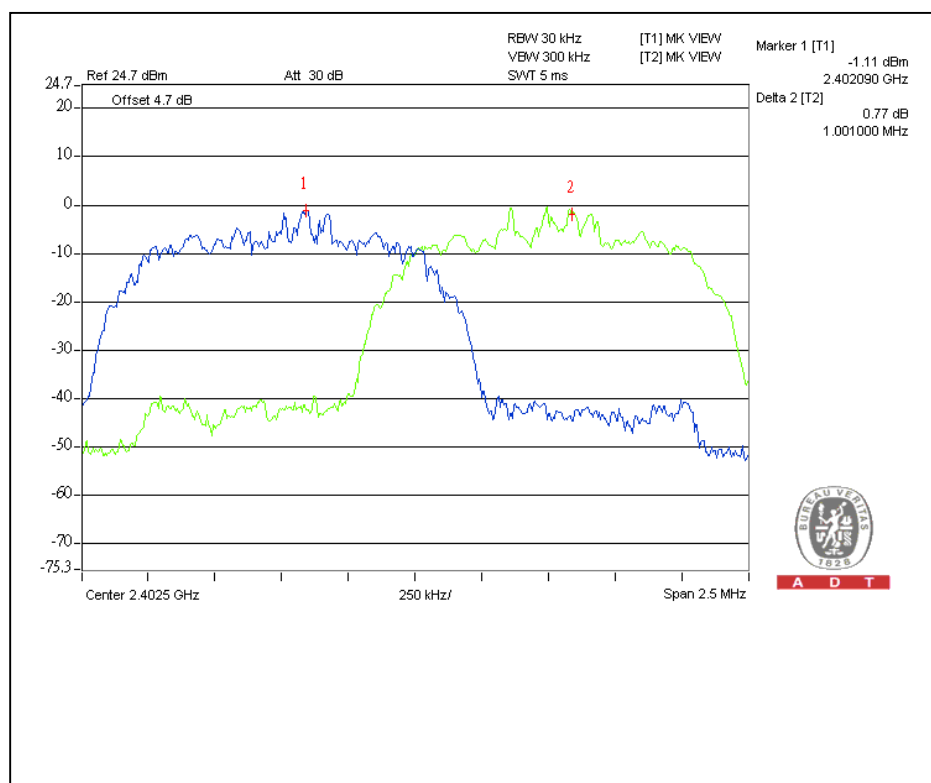



A D T

Channel 39

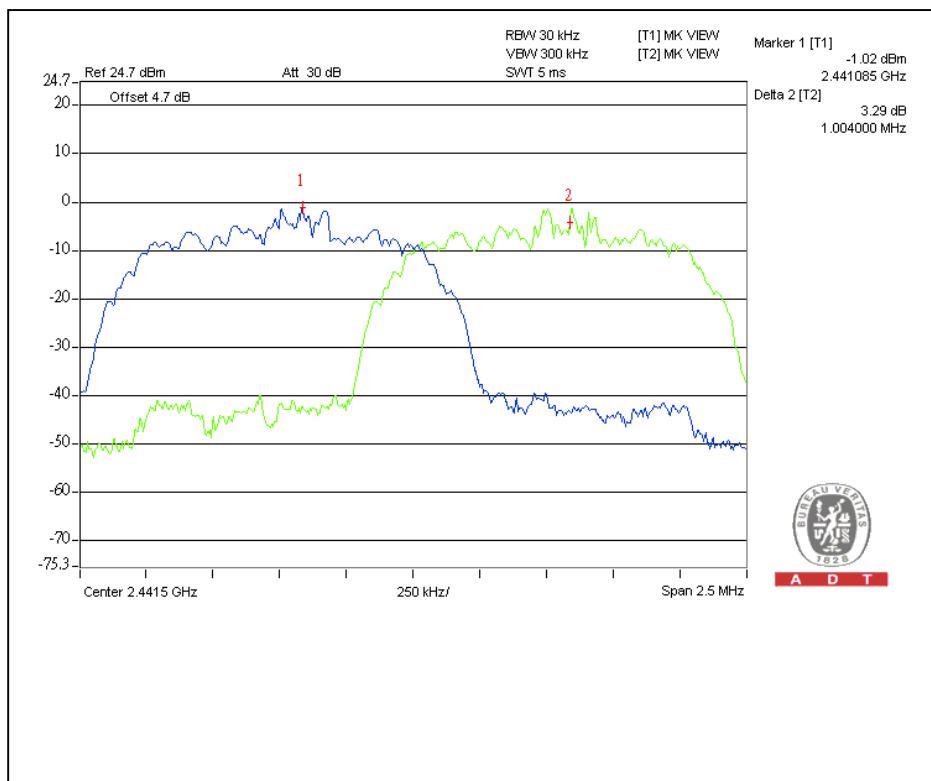

Channel 78

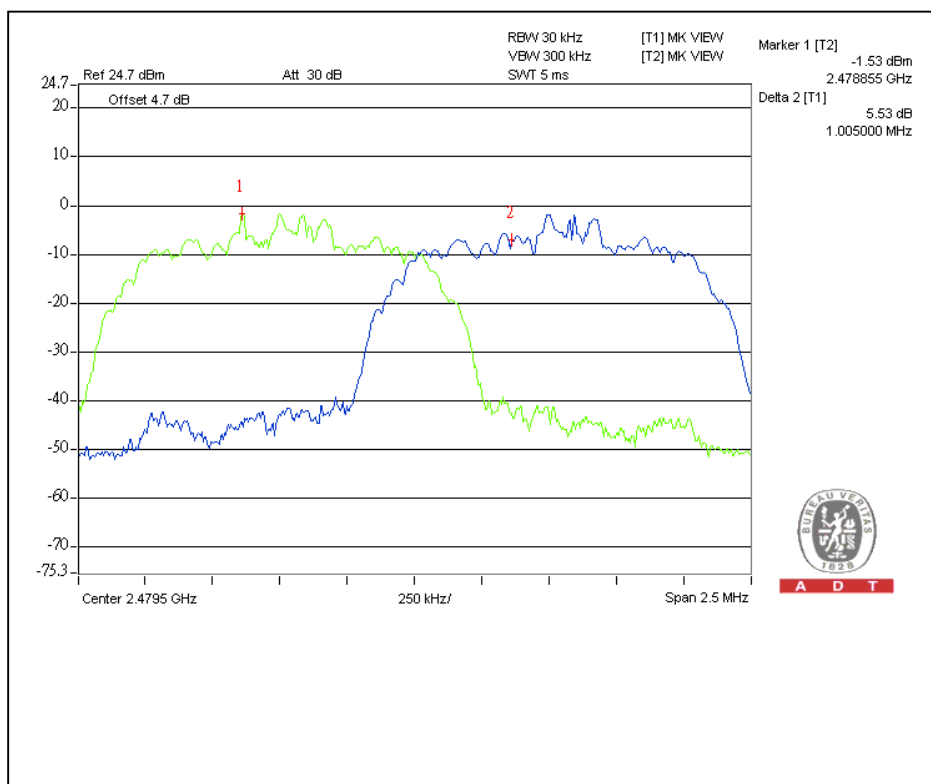

4.6 MAXIMUM PEAK OUTPUT POWER

4.6.1 LIMITS OF MAXIMUM PEAK OUTPUT POWER MEASUREMENT

The Maximum Peak Output Power Limit is 125mW.

4.6.2 INSTRUMENTS

DESCRIPTION & MANUFACTURER	MODEL NO.	SERIAL NO.	CALIBRATED DATE	CALIBRATED UNTIL
R&S SPECTRUM ANALYZER	FSP40	100037	Aug. 09, 2009	Aug. 08, 2010

NOTE:

1. The calibration interval of the above test instruments is 12 months and the calibrations are traceable to NML/ROC and NIST/USA.

4.6.3 TEST PROCEDURES

1. Check the calibration of the measuring instrument using either an internal calibrator or a known signal from an external generator.
2. Turn on the EUT and connect it to measurement instrument. Then set it to any one convenient frequency within its operating range. Set a reference level on the measuring instrument equal to the highest peak value.
3. The center frequency of the spectrum analyzer is set to the fundamental frequency and using 3 MHz RBW and 3 MHz VBW.
4. Measure the captured power within the band and recording the plot.
5. Repeat above procedures until all frequencies measured were complete.

4.6.4 DEVIATION FROM TEST STANDARD

No deviation

4.6.5 TEST SETUP



For the actual test configuration, please refer to the related Item – Photographs of the Test Configuration.

4.6.6 EUT OPERATING CONDITION

The software provided by client enabled the EUT to transmit and receive data at lowest, middle and highest channel frequencies individually.



A D T

4.6.7 TEST RESULTS

MODULATION TYPE	GFSK	INPUT POWER (SYSTEM)	120Vac, 60 Hz
ENVIRONMENTAL CONDITIONS	25deg. C, 60%RH, 965 hPa	TESTED BY	Wen Yu

CHANNEL	CHANNEL FREQUENCY (MHz)	PEAK POWER OUTPUT (mW)	PEAK POWER OUTPUT (dBm)	PEAK POWER LIMIT (mW)	PASS/FAIL
0	2402	1.445	1.60	125	PASS
39	2441	1.426	1.54	125	PASS
78	2480	1.219	0.86	125	PASS

Channel 0

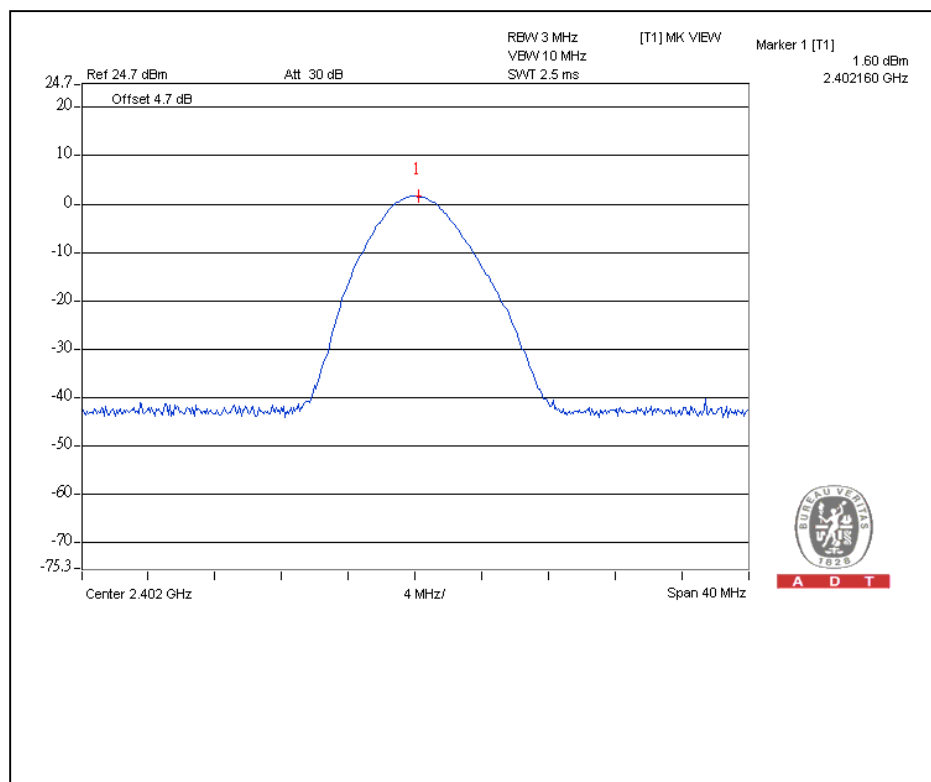



A D T

Channel 39

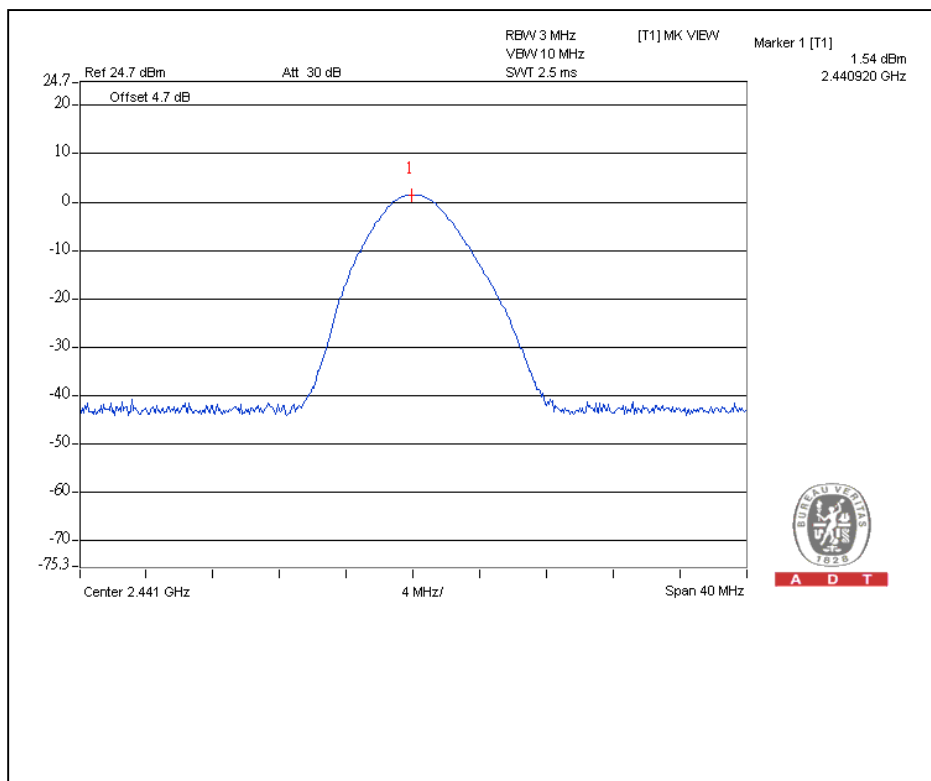

Channel 78

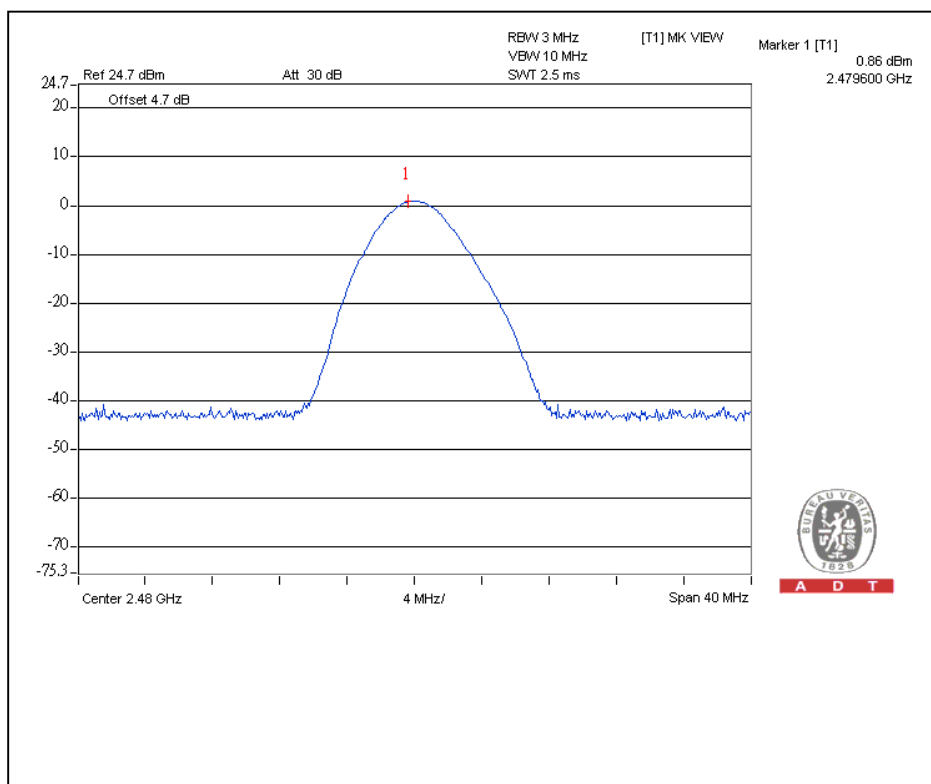



A D T

MODULATION TYPE	8DPSK	INPUT POWER (SYSTEM)	120Vac, 60 Hz
ENVIRONMENTAL CONDITIONS	25deg. C, 60%RH, 965 hPa	TESTED BY	Wen Yu

CHANNEL	CHANNEL FREQUENCY (MHz)	PEAK POWER OUTPUT (mW)	PEAK POWER OUTPUT (dBm)	PEAK POWER LIMIT (mW)	PASS/FAIL
0	2402	2.449	3.89	125	PASS
39	2441	2.410	3.82	125	PASS
78	2480	2.051	3.12	125	PASS

Channel 0

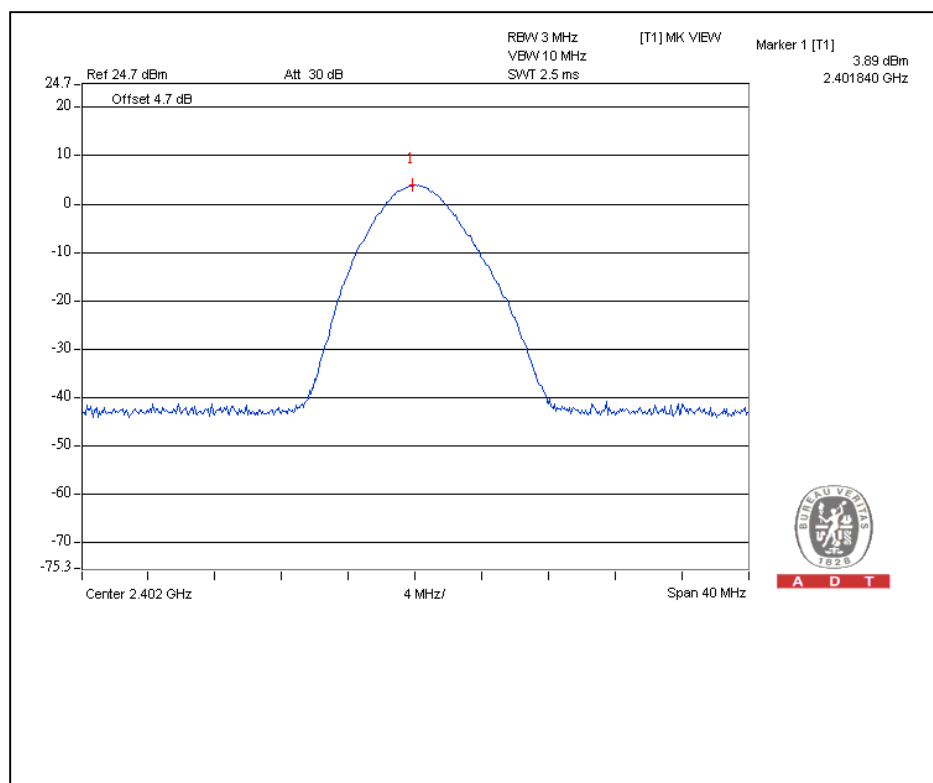



A D T

Channel 39

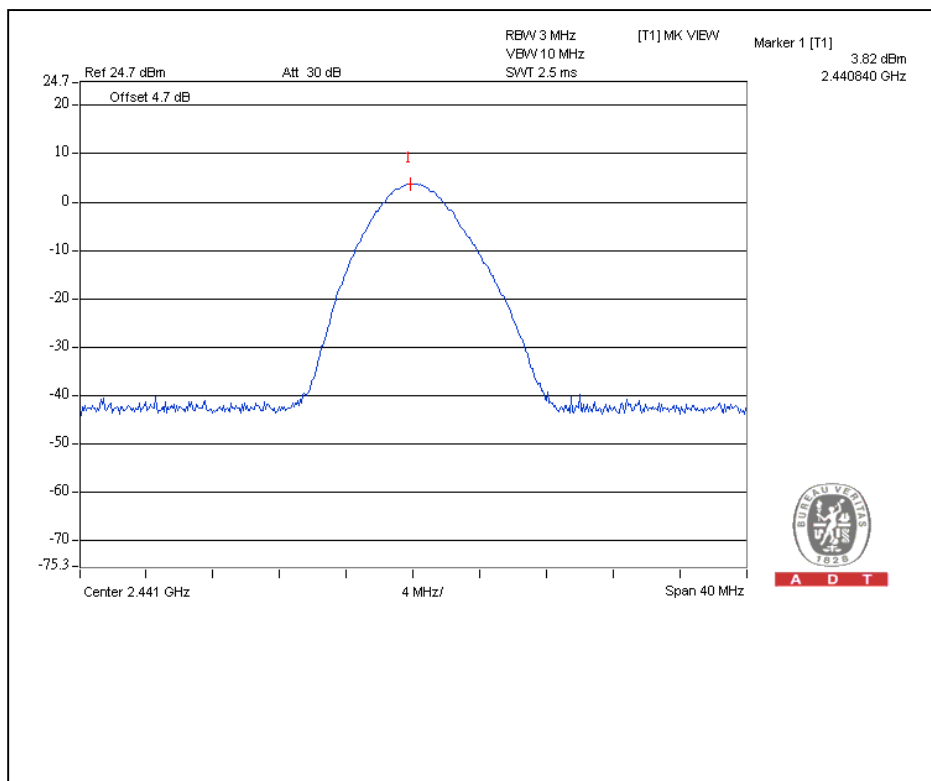

Channel 78

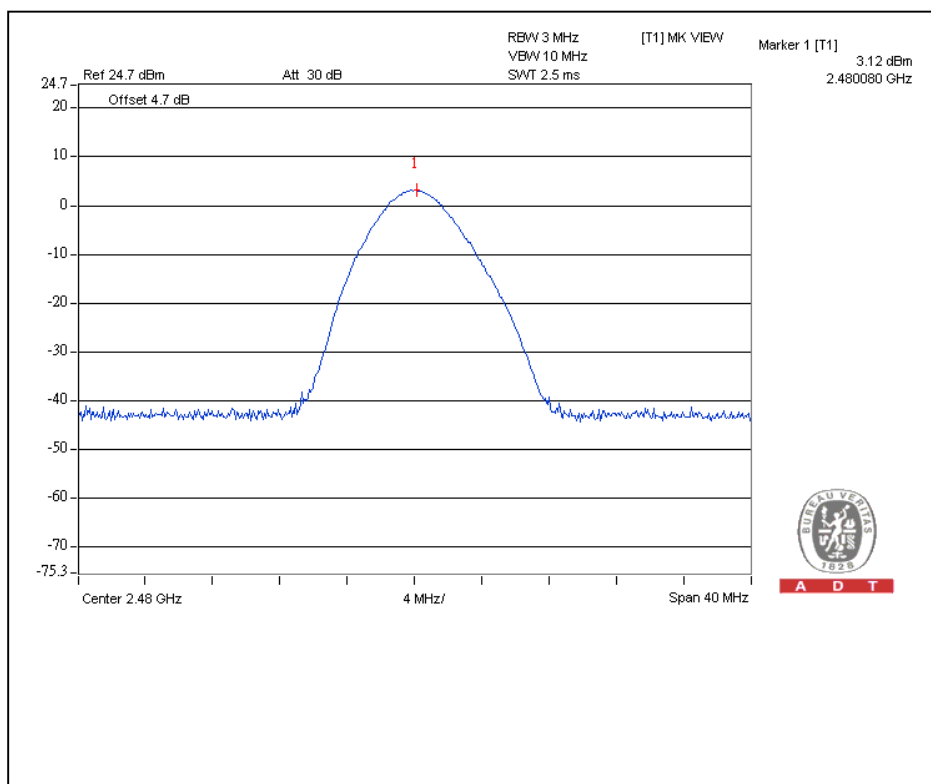



A D T

MODULATION TYPE	$\pi/4$ -DQPSK	INPUT POWER (SYSTEM)	120Vac, 60 Hz
ENVIRONMENTAL CONDITIONS	25deg. C, 60%RH, 965 hPa	TESTED BY	Wen Yu

CHANNEL	CHANNEL FREQUENCY (MHz)	PEAK POWER OUTPUT (mW)	PEAK POWER OUTPUT (dBm)	PEAK POWER LIMIT (mW)	PASS/FAIL
0	2402	2.265	3.55	125	PASS
39	2441	2.143	3.31	125	PASS
78	2480	1.928	2.85	125	PASS

Channel 0

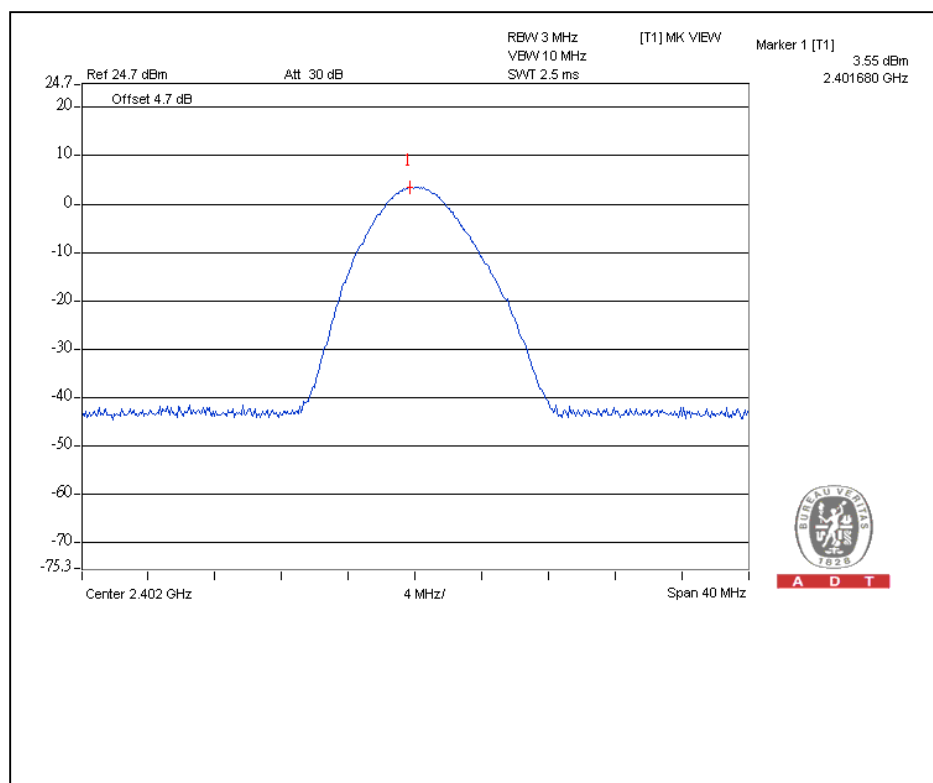



A D T

Channel 39

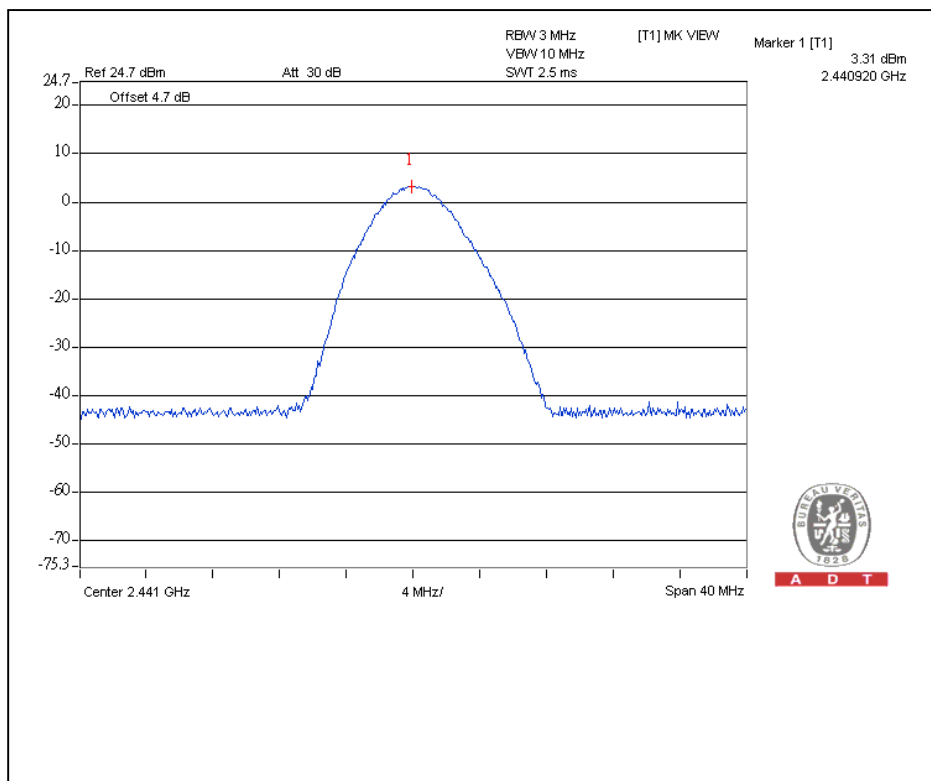

Channel 78

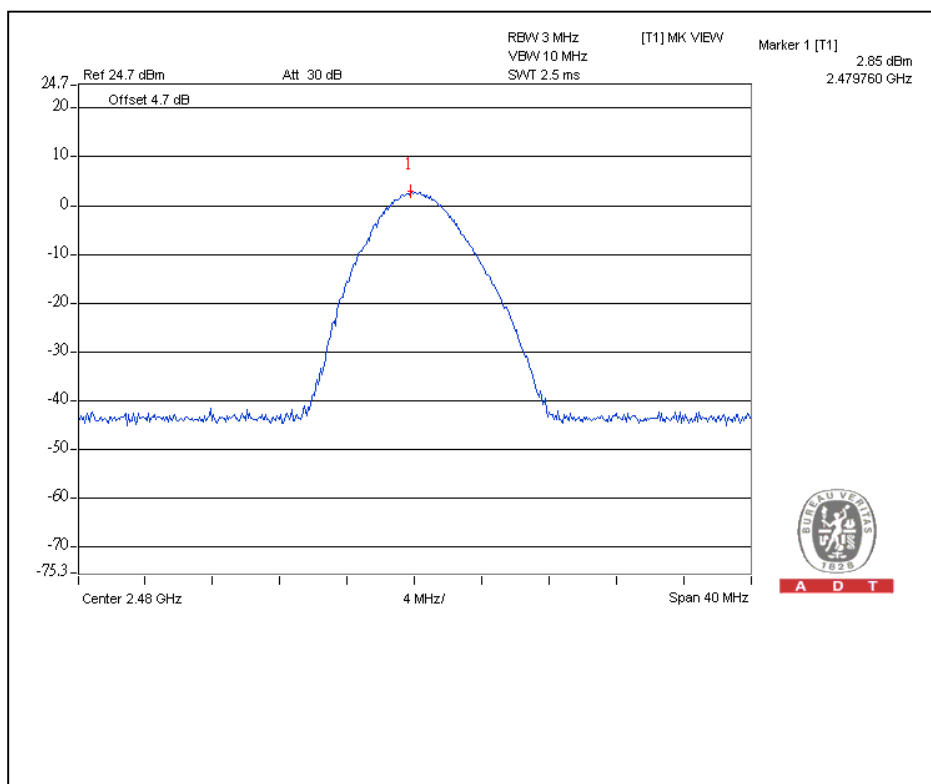

4.7 RADIATED EMISSION MEASUREMENT

4.7.1 LIMITS OF RADIATED EMISSION MEASUREMENT

Emissions radiated outside of the specified bands, shall be according to the general radiated limits in 15.209 as following:

Frequencies (MHz)	Field strength (microvolts/meter)	Measurement distance (meters)
0.009-0.490	2400/F(kHz)	300
0.490-1.705	24000/F(kHz)	30
1.705-30.0	30	30
30-88	100	3
88-216	150	3
216-960	200	3
Above 960	500	3

As shown in 15.35(b), for frequencies above 1000MHz, the field strength limits are based on average detector, however, the peak field strength of any emission shall not exceed the maximum permitted average limits, specified above by more than 20dB under any condition of modulation.



A D T

4.7.2 TEST INSTRUMENTS

DESCRIPTION & MANUFACTURER	MODEL NO.	SERIAL NO.	CALIBRATED DATE	CALIBRATED UNTIL
ROHDE & SCHWARZ Spectrum Analyzer	FSP40	100036	Dec. 09, 2008	Dec. 08, 2009
Agilent PSA Spectrum Analyzer	E4446A	MY46180622	Apr. 24 , 2009	Apr. 23 , 2010
HP Pre_Amplifier	8449B	3008A01923	Nov. 10, 2008	Nov. 09, 2009
ROHDE & SCHWARZ Test Receiver	ESCS30	847124/029	Sep. 09, 2008	Sep. 08, 2009
SCHWARZBECK TRILOG Broadband Antenna	VULB 9168	138	April 29, 2009	April 28, 2010
Schwarzbeck Horn_Antenna	BBHA9120	D124	Dec. 09, 2008	Dec. 08, 2009
Schwarzbeck Horn_Antenna	BBHA 9170	BBHA9170153	Jan. 22, 2009	Jan. 21, 2010
RF Switches	EMH-011	08009	Oct. 07, 2008	Oct. 06, 2009
RF CABLE (Chaintek)	Sucoflex 106	28077	Aug. 15, 2009	Aug. 14, 2010
RF Cable	8DFB	STCCAB-30M-1GHz	Oct. 07, 2008	Oct. 06, 2009
Software	ADT_Radiated_V7.6.15.9.2	NA	NA	NA
CT Antenna Tower & Turn Table	NA	NA	NA	NA

Note: 1. The calibration interval of the above test instruments is 12 months and the calibrations are traceable to NML/ROC and NIST/USA.

2. The horn antenna, HP preamplifier (model: 8449B) and Spectrum Analyzer (model: FSP40) are used only for the measurement of emission frequency above 1GHz if tested.

3. The test was performed in Open Site No. C.

4. The FCC Site Registration No. is 656396.

5. The VCCI Site Registration No. is R-1626.

6. The CANADA Site Registration No. is IC 7450G-3.

4.7.3 TEST PROCEDURES

- a. The EUT was placed on the top of a rotating table 0.8 meters above the ground at a 10 meter open area test site. The table was rotated 360 degrees to determine the position of the highest radiation.
- b. The EUT was set 3 meters away from the interference-receiving antenna, which was mounted on the top of a variable-height antenna tower.
- c. The antenna is a broadband antenna, and its height is varied from one meter to four meters above the ground to determine the maximum value of the field strength. Both horizontal and vertical polarizations of the antenna are set to make the measurement.
- d. For each suspected emission, the EUT was arranged to its worst case and then the antenna was tuned to heights from 1 meter to 4 meters and the rotatable table was turned from 0 degrees to 360 degrees to find the maximum reading.
- e. The test-receiver system was set to Peak Detect Function and Specified Bandwidth with Maximum Hold Mode.
- f. If the emission level of the EUT in peak mode was 10 dB lower than the limit specified, then testing could be stopped and the peak values of the EUT would be reported. Otherwise the emissions that did not have 10 dB margin would be re-tested one by one using peak, quasi-peak or average method as specified and then reported in a data sheet.

NOTE:

1. The resolution bandwidth and video bandwidth of test receiver/spectrum analyzer is 120kHz for Peak detection (PK) and Quasi-peak detection (QP) at frequency below 1GHz.
2. The resolution bandwidth is 1MHz and video bandwidth of test receiver/spectrum analyzer is 3MHz for Peak detection at frequency above 1GHz.

4.7.4 DEVIATION FROM TEST STANDARD

No deviation

4.7.5 TEST SETUP

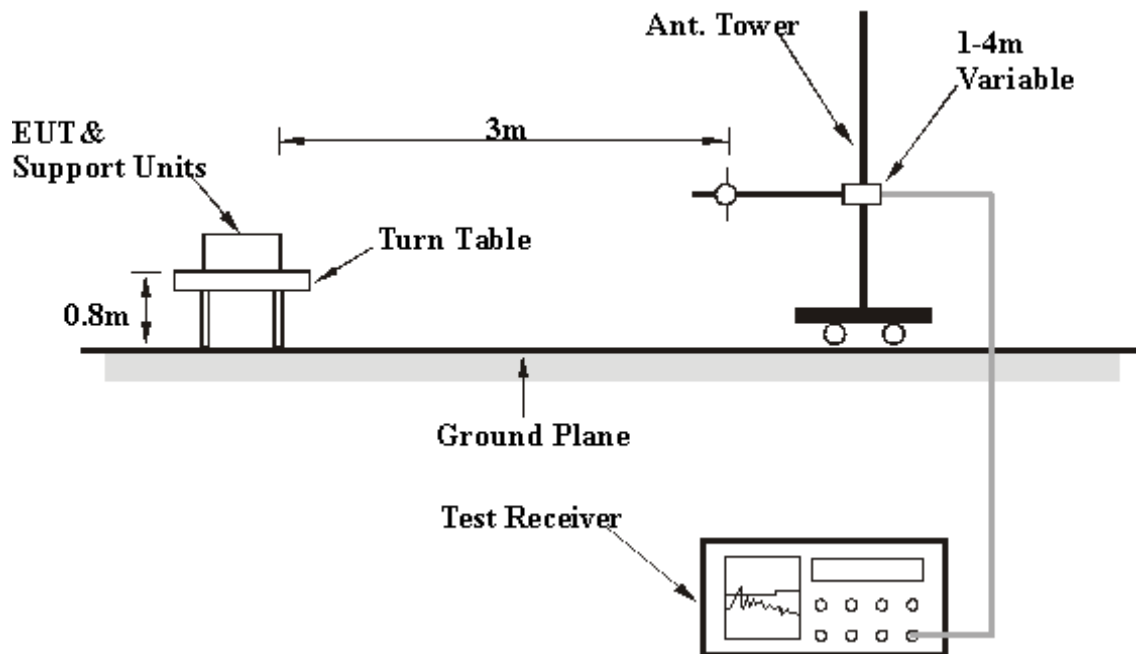

For the actual test configuration, please refer to the related item – Photographs of the Test Configuration.

4.7.6 TEST RESULTS

BELOW 1GHz WORST-CASE DATA : 8DPSK MODULATION

EUT TEST CONDITION		MEASUREMENT DETAIL	
CHANNEL	Channel 0	FREQUENCY RANGE	Below 1000MHz
INPUT POWER (SYSTEM)	120Vac, 60 Hz	DETECTOR FUNCTION	Quasi-Peak
ENVIRONMENTAL CONDITIONS	29.0deg. C, 55.0%RH 965hPa	TESTED BY	Frank Liu

ANTENNA POLARITY & TEST DISTANCE: HORIZONTAL AT 3 M								
NO.	FREQ. (MHz)	EMISSION LEVEL (dBuV/m)	LIMIT (dBuV/m)	MARGIN (dB)	ANTENNA HEIGHT (m)	TABLE ANGLE (Degree)	RAW VALUE (dBuV)	CORRECTION FACTOR (dB/m)
1	38.64	28.91 QP	40.00	-11.09	1.00 H	214	14.62	14.29
2	75.44	26.32 QP	40.00	-13.68	1.00 H	254	14.32	12.00
3	125.00	25.46 QP	43.50	-18.04	1.00 H	21	12.39	13.07
4	250.00	30.69 QP	46.00	-15.31	1.00 H	87	16.44	14.25
5	375.00	32.11 QP	46.00	-13.89	1.10 H	241	13.30	18.81
6	500.00	28.93 QP	46.00	-17.07	1.23 H	247	6.44	22.49
ANTENNA POLARITY & TEST DISTANCE: VERTICAL AT 3 M								
NO.	FREQ. (MHz)	EMISSION LEVEL (dBuV/m)	LIMIT (dBuV/m)	MARGIN (dB)	ANTENNA HEIGHT (m)	TABLE ANGLE (Degree)	RAW VALUE (dBuV)	CORRECTION FACTOR (dB/m)
1	40.12	30.82 QP	40.00	-9.18	1.00 V	31	16.24	14.58
2	80.21	24.50 QP	40.00	-15.50	1.00 V	54	13.66	10.84
3	125.00	24.52 QP	43.50	-18.98	1.00 V	221	11.45	13.07
4	250.00	26.80 QP	46.00	-19.20	1.00 V	324	12.55	14.25
5	375.00	31.59 QP	46.00	-14.41	1.10 V	118	12.78	18.81
6	500.00	30.84 QP	46.00	-15.16	1.23 V	142	8.35	22.49

- REMARKS:**
1. Emission level (dBuV/m) = Raw Value (dBuV) + Correction Factor (dB/m).
 2. Correction Factor (dB/m) = Antenna Factor (dB/m) + Cable Factor (dB).
 3. The other emission levels were very low against the limit.
 4. Margin value = Emission level – Limit value.



A D T

ABOVE 1GHZ WORST-CASE DATA : GFSK MODULATION

EUT TEST CONDITION		MEASUREMENT DETAIL	
CHANNEL	Channel 0	FREQUENCY RANGE	1 ~ 25GHz
INPUT POWER (SYSTEM)	120Vac, 60 Hz	DETECTOR FUNCTION	Peak (PK) Average (AV)
ENVIRONMENTAL CONDITIONS	37.0deg. C, 55.0%RH 965hPa	TESTED BY	Eric Lee

ANTENNA POLARITY & TEST DISTANCE: HORIZONTAL AT 3 M								
NO.	FREQ. (MHz)	EMISSION LEVEL (dBuV/m)	LIMIT (dBuV/m)	MARGIN (dB)	ANTENNA HEIGHT (m)	TABLE ANGLE (Degree)	RAW VALUE (dBuV)	CORRECTION FACTOR (dB/m)
1	2385.61	55.46 PK	74.00	-18.54	1.70 H	279	25.19	30.27
2	2385.61	25.46 AV	54.00	-28.54	1.70 H	279	-4.81	30.27
3	*2402.00	99.28 PK			1.79 H	279	68.95	30.33
4	*2402.00	69.28 AV			1.79 H	279	38.95	30.33
5	4804.00	42.78 PK	74.00	-31.22	1.11 H	48	6.05	36.73
6	4804.00	12.78 AV	54.00	-41.22	1.11 H	48	-23.95	36.73
ANTENNA POLARITY & TEST DISTANCE: VERTICAL AT 3 M								
NO.	FREQ. (MHz)	EMISSION LEVEL (dBuV/m)	LIMIT (dBuV/m)	MARGIN (dB)	ANTENNA HEIGHT (m)	TABLE ANGLE (Degree)	RAW VALUE (dBuV)	CORRECTION FACTOR (dB/m)
1	2373.01	55.57 PK	74.00	-18.43	1.49 V	244	25.35	30.22
2	2373.01	25.57 AV	54.00	-28.43	1.49 V	244	-4.65	30.22
3	*2402.00	92.51 PK			1.50 V	263	62.18	30.33
4	*2402.00	62.51 AV			1.50 V	263	32.18	30.33
5	4804.00	43.72 PK	74.00	-30.28	1.38 V	78	6.99	36.73
6	4804.00	13.72 AV	54.00	-40.28	1.38 V	78	-23.01	36.73

- REMARKS:**
1. Emission level (dBuV/m) = Raw Value (dBuV) + Correction Factor (dB/m).
 2. Correction Factor (dB/m) = Antenna Factor (dB/m) + Cable Factor (dB).
 3. The other emission levels were very low against the limit.
 4. Margin value = Emission level – Limit value.
 5. “ * “: Fundamental frequency.
 6. The DH5 packet was the worse case duty cycle for a transmit dwell time on a channel, based upon bluetooth theory the transmitter is on 0.625 * 5 per 296.25 ms per channel. Therefore, the duty cycle correlation factor be equal to: $20\log(3.125 / 100) = -30.1$ dB.
 7. Average value = peak reading + $20\log(\text{duty cycle})$.



A D T

EUT TEST CONDITION		MEASUREMENT DETAIL	
CHANNEL	Channel 39	FREQUENCY RANGE	1 ~ 25GHz
INPUT POWER (SYSTEM)	120Vac, 60 Hz	DETECTOR FUNCTION	Peak (PK) Average (AV)
ENVIRONMENTAL CONDITIONS	37.0deg. C, 55.0%RH 965hPa	TESTED BY	Eric Lee

ANTENNA POLARITY & TEST DISTANCE: HORIZONTAL AT 3 M								
NO.	FREQ. (MHz)	EMISSION LEVEL (dBuV/m)	LIMIT (dBuV/m)	MARGIN (dB)	ANTENNA HEIGHT (m)	TABLE ANGLE (Degree)	RAW VALUE (dBuV)	CORRECTION FACTOR (dB/m)
1	*2441.00	99.54 PK			1.63 H	282	69.07	30.47
2	*2441.00	69.54 AV			1.63 H	282	39.07	30.47
3	4882.00	43.58 PK	74.00	-30.42	1.60 H	82	6.64	36.94
4	4882.00	13.58 AV	54.00	-40.42	1.60 H	82	-23.36	36.94
5	7323.00	51.98 PK	74.00	-22.02	1.47 H	194	8.85	43.13
6	7323.00	21.98 AV	54.00	-32.02	1.47 H	194	-21.15	43.13
ANTENNA POLARITY & TEST DISTANCE: VERTICAL AT 3 M								
NO.	FREQ. (MHz)	EMISSION LEVEL (dBuV/m)	LIMIT (dBuV/m)	MARGIN (dB)	ANTENNA HEIGHT (m)	TABLE ANGLE (Degree)	RAW VALUE (dBuV)	CORRECTION FACTOR (dB/m)
1	*2441.00	93.48 PK			1.42 V	257	63.01	30.47
2	*2441.00	63.48 AV			1.42 V	257	33.01	30.47
3	4882.00	44.69 PK	74.00	-29.31	1.29 V	316	7.75	36.94
4	4882.00	14.69 AV	54.00	-39.31	1.29 V	316	-22.25	36.94
5	7323.00	51.28 PK	74.00	-22.72	1.34 V	200	8.15	43.13
6	7323.00	21.28 AV	54.00	-32.72	1.34 V	200	-21.85	43.13

- REMARKS:**
1. Emission level (dBuV/m) = Raw Value (dBuV) + Correction Factor (dB/m).
 2. Correction Factor (dB/m) = Antenna Factor (dB/m) + Cable Factor (dB).
 3. The other emission levels were very low against the limit.
 4. Margin value = Emission level – Limit value.
 5. “ * “: Fundamental frequency.
 6. The DH5 packet was the worse case duty cycle for a transmit dwell time on a channel, based upon bluetooth theory the transmitter is on 0.625 * 5 per 296.25 ms per channel. Therefore, the duty cycle correlation factor be equal to: $20\log(3.125 / 100) = -30.1$ dB.
 7. Average value = peak reading + $20\log(\text{duty cycle})$.



A D T

EUT TEST CONDITION		MEASUREMENT DETAIL	
CHANNEL	Channel 78	FREQUENCY RANGE	1 ~ 25GHz
INPUT POWER (SYSTEM)	120Vac, 60 Hz	DETECTOR FUNCTION	Peak (PK) Average (AV)
ENVIRONMENTAL CONDITIONS	37.0deg. C, 55.0%RH 965hPa	TESTED BY	Eric Lee

ANTENNA POLARITY & TEST DISTANCE: HORIZONTAL AT 3 M

NO.	FREQ. (MHz)	EMISSION LEVEL (dBuV/m)	LIMIT (dBuV/m)	MARGIN (dB)	ANTENNA HEIGHT (m)	TABLE ANGLE (Degree)	RAW VALUE (dBuV)	CORRECTION FACTOR (dB/m)
1	*2480.00	101.99 PK			1.58 H	272	71.37	30.62
2	*2480.00	71.99 AV			1.58 H	272	41.37	30.62
3	2484.86	55.75 PK	74.00	-18.25	1.59 H	269	25.12	30.63
4	2484.86	25.75 AV	54.00	-28.25	1.59 H	269	-4.88	30.63
5	4960.00	43.69 PK	74.00	-30.31	1.48 H	69	6.54	37.15
6	4960.00	13.69 AV	54.00	-40.31	1.48 H	69	-23.46	37.15
7	7440.00	52.71 PK	74.00	-21.29	1.52 H	360	9.59	43.12
8	7440.00	22.71 AV	54.00	-31.29	1.52 H	360	-20.41	43.12

ANTENNA POLARITY & TEST DISTANCE: VERTICAL AT 3 M

NO.	FREQ. (MHz)	EMISSION LEVEL (dBuV/m)	LIMIT (dBuV/m)	MARGIN (dB)	ANTENNA HEIGHT (m)	TABLE ANGLE (Degree)	RAW VALUE (dBuV)	CORRECTION FACTOR (dB/m)
1	*2480.00	94.87 PK			1.39 V	248	64.25	30.62
2	*2480.00	64.87 AV			1.39 V	248	34.25	30.62
3	2483.74	55.57 PK	74.00	-18.43	1.38 V	251	24.94	30.63
4	2483.74	25.57 AV	54.00	-28.43	1.38 V	251	-5.06	30.63
5	4960.00	43.36 PK	74.00	-30.64	1.28 V	14	6.21	37.15
6	4960.00	13.36 AV	54.00	-40.64	1.28 V	14	-23.79	37.15
7	7440.00	51.01 PK	74.00	-22.99	1.33 V	28	7.89	43.12
8	7440.00	21.01 AV	54.00	-32.99	1.33 V	28	-22.11	43.12

- REMARKS:**
- Emission level (dBuV/m) = Raw Value (dBuV) + Correction Factor (dB/m).
 - Correction Factor (dB/m) = Antenna Factor (dB/m) + Cable Factor (dB).
 - The other emission levels were very low against the limit.
 - Margin value = Emission level – Limit value.
 - * * *: Fundamental frequency.
 - The DH5 packet was the worse case duty cycle for a transmit dwell time on a channel, based upon bluetooth theory the transmitter is on 0.625 * 5 per 296.25 ms per channel. Therefore, the duty cycle correlation factor be equal to: $20\log(3.125 / 100) = -30.1$ dB.
 - Average value = peak reading + $20\log(\text{duty cycle})$.

ABOVE 1GHZ WORST-CASE DATA : 8DPSK MODULATION

EUT TEST CONDITION		MEASUREMENT DETAIL	
CHANNEL	Channel 0	FREQUENCY RANGE	1 ~ 25GHz
INPUT POWER (SYSTEM)	120Vac, 60 Hz	DETECTOR FUNCTION	Peak (PK) Average (AV)
ENVIRONMENTAL CONDITIONS	37.0deg. C, 55.0%RH 965hPa	TESTED BY	Eric Lee

ANTENNA POLARITY & TEST DISTANCE: HORIZONTAL AT 3 M								
NO.	FREQ. (MHz)	EMISSION LEVEL (dBuV/m)	LIMIT (dBuV/m)	MARGIN (dB)	ANTENNA HEIGHT (m)	TABLE ANGLE (Degree)	RAW VALUE (dBuV)	CORRECTION FACTOR (dB/m)
1	2384.20	54.89 PK	74.00	-19.11	1.43 H	208	24.63	30.26
2	2384.20	24.89 AV	54.00	-29.11	1.43 H	208	-5.37	30.26
3	*2402.00	104.92 PK			1.43 H	208	74.59	30.33
4	*2402.00	74.92 AV			1.43 H	208	44.59	30.33
5	4804.00	42.19 PK	74.00	-31.81	1.40 H	296	5.46	36.73
6	4804.00	12.19 AV	54.00	-41.81	1.40 H	296	-24.54	36.73
ANTENNA POLARITY & TEST DISTANCE: VERTICAL AT 3 M								
NO.	FREQ. (MHz)	EMISSION LEVEL (dBuV/m)	LIMIT (dBuV/m)	MARGIN (dB)	ANTENNA HEIGHT (m)	TABLE ANGLE (Degree)	RAW VALUE (dBuV)	CORRECTION FACTOR (dB/m)
1	2362.70	54.22 PK	74.00	-19.78	1.69 V	268	24.04	30.18
2	2362.70	24.22 AV	54.00	-29.78	1.69 V	268	-5.96	30.18
3	*2402.00	95.98 PK			1.69 V	262	65.65	30.33
4	*2402.00	65.98 AV			1.69 V	262	35.65	30.33
5	4804.00	42.08 PK	74.00	-31.92	1.39 V	246	5.35	36.73
6	4804.00	12.08 AV	54.00	-41.92	1.39 V	246	-24.65	36.73

- REMARKS:**
1. Emission level (dBuV/m) = Raw Value (dBuV) + Correction Factor (dB/m).
 2. Correction Factor (dB/m) = Antenna Factor (dB/m) + Cable Factor (dB).
 3. The other emission levels were very low against the limit.
 4. Margin value = Emission level – Limit value.
 5. “ * “: Fundamental frequency.
 6. The DH5 packet was the worse case duty cycle for a transmit dwell time on a channel, based upon bluetooth theory the transmitter is on 0.625 * 5 per 296.25 ms per channel. Therefore, the duty cycle correlation factor be equal to: $20\log(3.125 / 100) = -30.1$ dB.
 7. Average value = peak reading + $20\log(\text{duty cycle})$.



A D T

EUT TEST CONDITION		MEASUREMENT DETAIL	
CHANNEL	Channel 39	FREQUENCY RANGE	1 ~ 25GHz
INPUT POWER (SYSTEM)	120Vac, 60 Hz	DETECTOR FUNCTION	Peak (PK) Average (AV)
ENVIRONMENTAL CONDITIONS	37.0deg. C, 55.0%RH 965hPa	TESTED BY	Eric Lee

ANTENNA POLARITY & TEST DISTANCE: HORIZONTAL AT 3 M

NO.	FREQ. (MHz)	EMISSION LEVEL (dBuV/m)	LIMIT (dBuV/m)	MARGIN (dB)	ANTENNA HEIGHT (m)	TABLE ANGLE (Degree)	RAW VALUE (dBuV)	CORRECTION FACTOR (dB/m)
1	*2441.00	104.46 PK			1.40 H	281	73.99	30.47
2	*2441.00	74.46 AV			1.40 H	281	43.99	30.47
3	4882.00	43.08 PK	74.00	-30.92	1.38 H	287	6.14	36.94
4	4882.00	13.08 AV	54.00	-40.92	1.38 H	287	-23.86	36.94
5	7323.00	52.33 PK	74.00	-21.67	1.26 H	84	9.20	43.13
6	7323.00	22.33 AV	54.00	-31.67	1.26 H	84	-20.80	43.13

ANTENNA POLARITY & TEST DISTANCE: VERTICAL AT 3 M

NO.	FREQ. (MHz)	EMISSION LEVEL (dBuV/m)	LIMIT (dBuV/m)	MARGIN (dB)	ANTENNA HEIGHT (m)	TABLE ANGLE (Degree)	RAW VALUE (dBuV)	CORRECTION FACTOR (dB/m)
1	*2441.00	95.59 PK			1.63 V	271	65.12	30.47
2	*2441.00	65.59 AV			1.63 V	271	35.12	30.47
3	4882.00	42.44 PK	74.00	-31.56	1.41 V	250	5.50	36.94
4	4882.00	12.44 AV	54.00	-41.56	1.41 V	250	-24.50	36.94
5	7323.00	51.69 PK	74.00	-22.31	1.50 V	169	8.56	43.13
6	7323.00	21.69 AV	54.00	-32.31	1.50 V	169	-21.44	43.13

- REMARKS:**
- Emission level (dBuV/m) = Raw Value (dBuV) + Correction Factor (dB/m).
 - Correction Factor (dB/m) = Antenna Factor (dB/m) + Cable Factor (dB).
 - The other emission levels were very low against the limit.
 - Margin value = Emission level – Limit value.
 - “ * “: Fundamental frequency.
 - The DH5 packet was the worse case duty cycle for a transmit dwell time on a channel, based upon bluetooth theory the transmitter is on 0.625 * 5 per 296.25 ms per channel. Therefore, the duty cycle correlation factor be equal to: $20\log(3.125 / 100) = -30.1$ dB.
 - Average value = peak reading + $20\log(\text{duty cycle})$.



A D T

EUT TEST CONDITION		MEASUREMENT DETAIL	
CHANNEL	Channel 78	FREQUENCY RANGE	1 ~ 25GHz
INPUT POWER (SYSTEM)	120Vac, 60 Hz	DETECTOR FUNCTION	Peak (PK) Average (AV)
ENVIRONMENTAL CONDITIONS	37.0deg. C, 55.0%RH 965hPa	TESTED BY	Eric Lee

ANTENNA POLARITY & TEST DISTANCE: HORIZONTAL AT 3 M

NO.	FREQ. (MHz)	EMISSION LEVEL (dBuV/m)	LIMIT (dBuV/m)	MARGIN (dB)	ANTENNA HEIGHT (m)	TABLE ANGLE (Degree)	RAW VALUE (dBuV)	CORRECTION FACTOR (dB/m)
1	*2480.00	104.45 PK			1.35 H	285	73.83	30.62
2	*2480.00	74.45 AV			1.35 H	285	43.83	30.62
3	2483.97	55.65 PK	74.00	-18.35	1.36 H	288	25.02	30.63
4	2483.97	25.65 AV	54.00	-28.35	1.36 H	288	-4.98	30.63
5	4960.00	43.47 PK	74.00	-30.53	1.29 H	68	6.32	37.15
6	4960.00	13.47 AV	54.00	-40.53	1.29 H	68	-23.68	37.15
7	7440.00	51.98 PK	74.00	-22.02	1.57 H	172	8.86	43.12
8	7440.00	21.98 AV	54.00	-32.02	1.57 H	172	-21.14	43.12

ANTENNA POLARITY & TEST DISTANCE: VERTICAL AT 3 M

NO.	FREQ. (MHz)	EMISSION LEVEL (dBuV/m)	LIMIT (dBuV/m)	MARGIN (dB)	ANTENNA HEIGHT (m)	TABLE ANGLE (Degree)	RAW VALUE (dBuV)	CORRECTION FACTOR (dB/m)
1	*2480.00	95.51 PK			1.58 V	269	64.89	30.62
2	*2480.00	65.51 AV			1.58 V	269	34.89	30.62
3	2484.48	55.66 PK	74.00	-18.34	1.53 V	283	25.03	30.63
4	2484.48	25.66 AV	54.00	-28.34	1.53 V	283	-4.97	30.63
5	4960.00	43.22 PK	74.00	-30.78	1.38 V	243	6.07	37.15
6	4960.00	13.22 AV	54.00	-40.78	1.38 V	243	-23.93	37.15
7	7440.00	51.72 PK	74.00	-22.28	1.59 V	188	8.60	43.12
8	7440.00	21.72 AV	54.00	-32.28	1.59 V	188	-21.40	43.12

- REMARKS:**
- Emission level (dBuV/m) = Raw Value (dBuV) + Correction Factor (dB/m).
 - Correction Factor (dB/m) = Antenna Factor (dB/m) + Cable Factor (dB).
 - The other emission levels were very low against the limit.
 - Margin value = Emission level – Limit value.
 - * * *: Fundamental frequency.
 - The DH5 packet was the worse case duty cycle for a transmit dwell time on a channel, based upon bluetooth theory the transmitter is on 0.625 * 5 per 296.25 ms per channel. Therefore, the duty cycle correlation factor be equal to: $20\log(3.125 / 100) = -30.1$ dB.
 - Average value = peak reading + $20\log(\text{duty cycle})$.

4.8 CONDUCTED OUT-BAND EMISSION MEASUREMENT

4.8.1 LIMITS OF CONDUCTED OUT-BAND EMISSION MEASUREMENT

Below -20dB of the highest emission level of operating band (in 100kHz RBW).

4.8.2 TEST INSTRUMENTS

DESCRIPTION & MANUFACTURER	MODEL NO.	SERIAL NO.	CALIBRATED DATE	CALIBRATED UNTIL
R&S SPECTRUM ANALYZER	FSP40	100037	Aug. 09, 2009	Aug. 08, 2010

NOTE:

1. The calibration interval of the above test instruments is 12 months and the calibrations are traceable to NML/ROC and NIST/USA.

4.8.3 TEST PROCEDURE

The transmitter output was connected to the spectrum analyzer via a low lose cable. Set RBW a of spectrum analyzer to 100 kHz and VBW of spectrum analyzer to 300 kHz with suitable frequency span including 100 MHz bandwidth from band edge. The band edges was measured and recorded.

4.8.4 DEVIATION FROM TEST STANDARD

No deviation

4.8.5 EUT OPERATING CONDITION

The software provided by client enabled the EUT to transmit and receive data at lowest, middle and highest channel frequencies individually.

4.8.6 TEST RESULTS

Emissions radiated outside of the specified frequency bands, please refer pages form 67 to 73 for met the requirement of the general radiated emission limits in § 15.209.

For GFSK MODULATION TYPE:

CH0

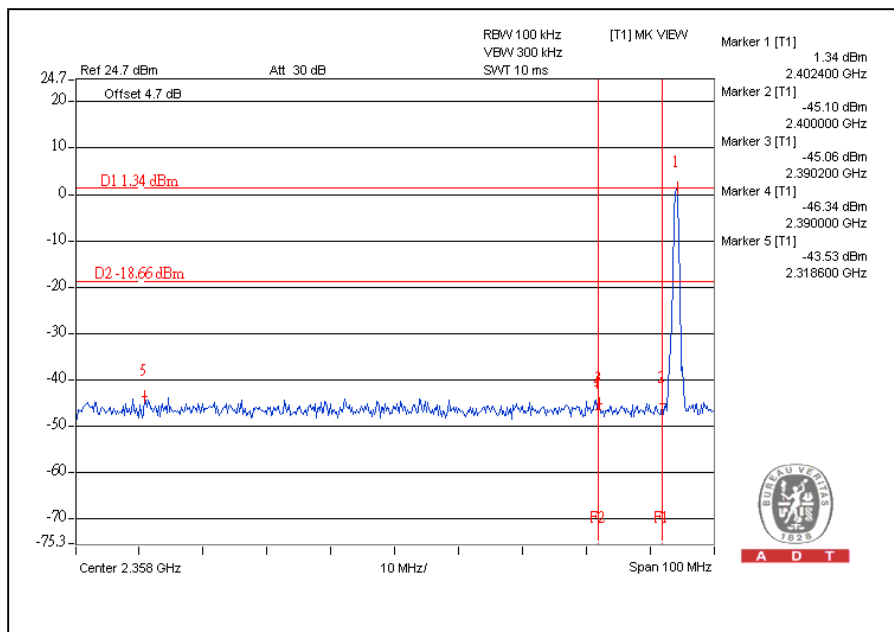

CH78

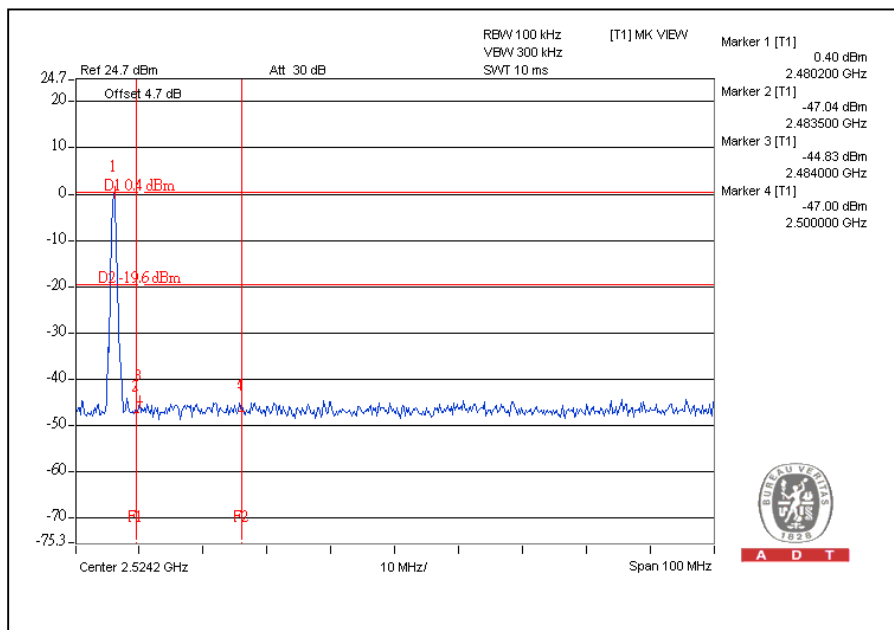



A D T

CH0

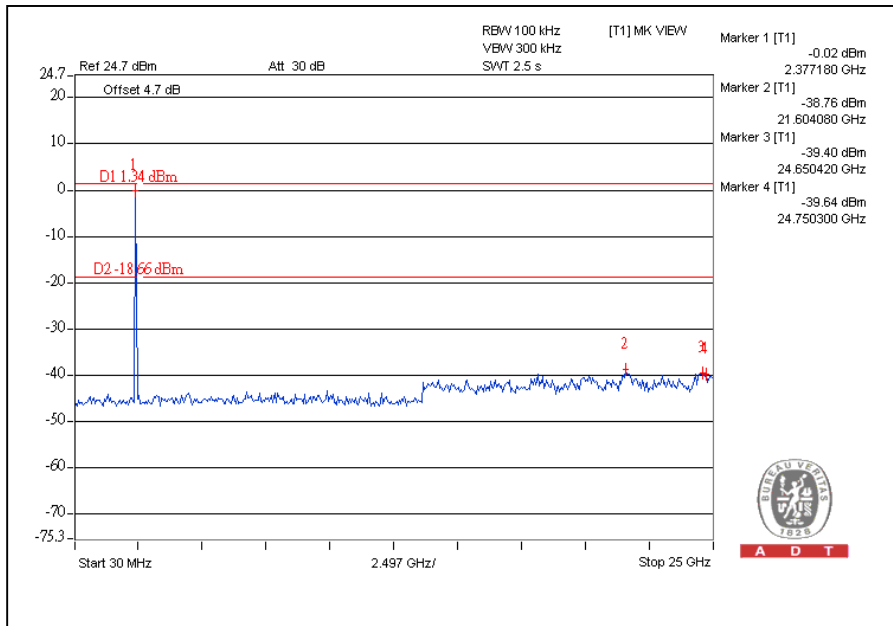

CH78

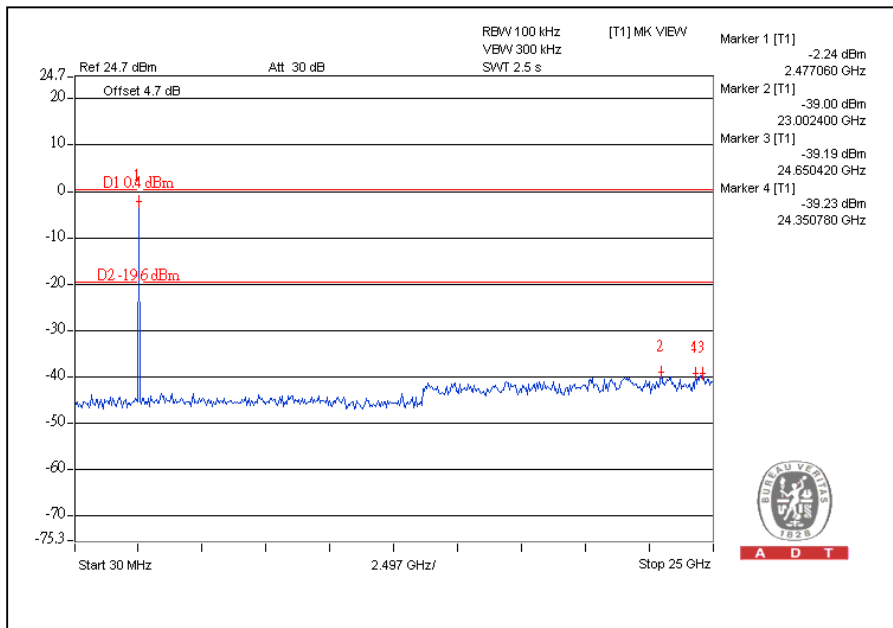



A D T

FOR 8DPSK MODULATION TYPE:

CH0

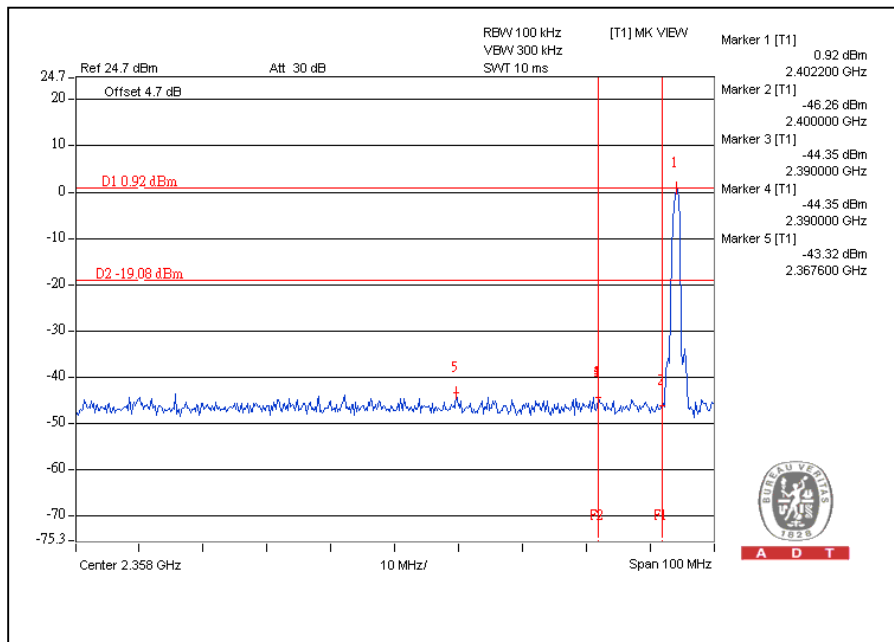

CH78

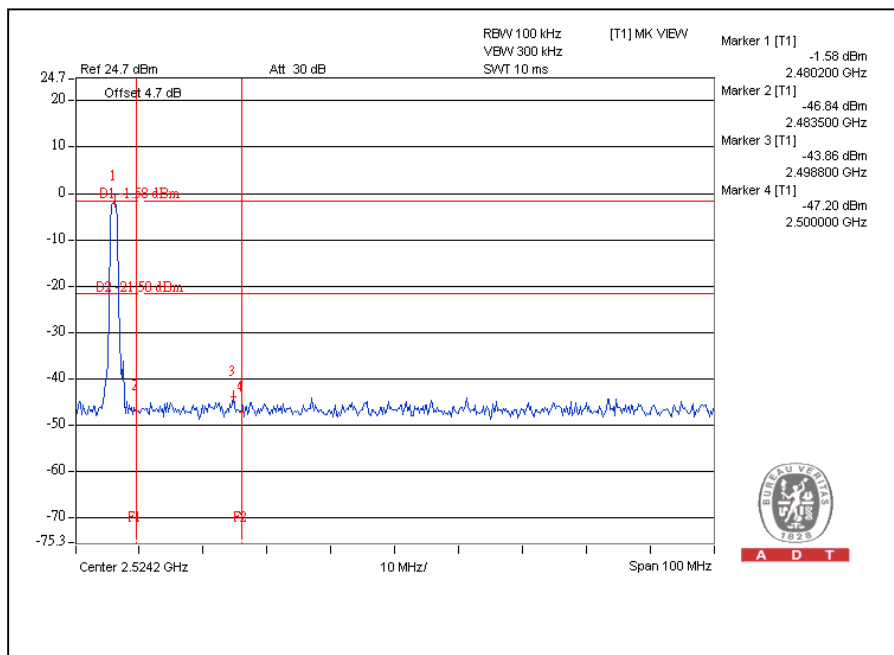



A D T

CH0

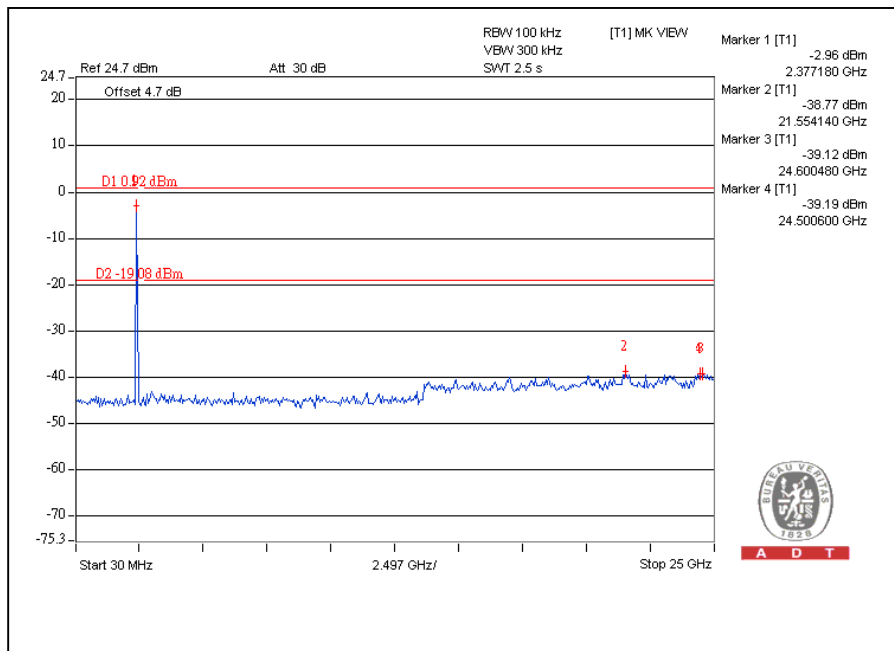

CH78

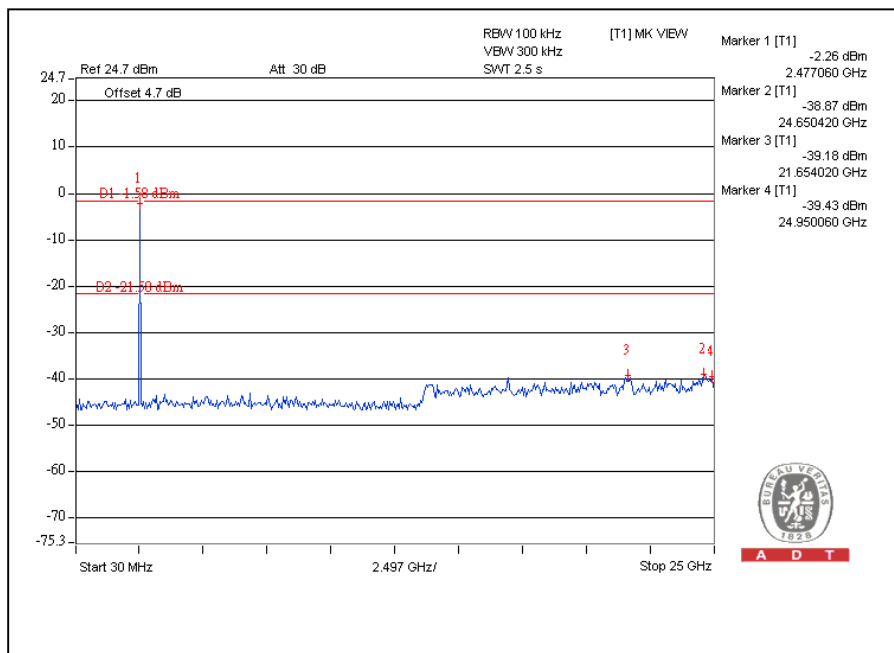

4.9 ANTENNA REQUIREMENT

4.9.1 STANDARD APPLICABLE

For intentional device, according to FCC 47 CFR Section 15.203, an intentional radiator shall be designed to ensure that no antenna other than that furnished by the responsible party shall be used with the device.

And according to FCC 47 CFR Section 15.247 (b), if transmitting antennas of directional gain greater than 6 dBi are used, the power shall be reduced by the amount in dB that the directional gain of the antenna exceeds 6 dBi.

4.9.2 ANTENNA CONNECTED CONSTRUCTION

There are nine antennas provided to this EUT, please refer to the following table:

For WLAN								
No.	Brand	Model	Antenna Type	Gain (dBi)	Connector Type	Frequency range (MHz)	Cable Loss(dB)	Cable Length
1	Laird (R Type)	Rot main	PIFA	0.37(2.4G) 4.81(5G)	Hirose U.FL	2400~2500 4900~5850	0.1~0.15	25 ± 0.5mm
2	Laird (R Type)	Rot aux	PIFA	1.63(2.4G) 4.93(5G)	Hirose U.FL	2400~2500 4900~5850	0.1~0.15	61 +2/-1mm
3	Laird (S Type)	Str main	PIFA	0.89(2.4G) 4.34(5G)	Hirose U.FL	2400~2500 4900~5850	0.1~0.15	25 ± 0.5mm
4	Laird (S Type)	Str aux	PIFA	1.09(2.4G) 4.52(5G)	Hirose U.FL	2400~2500 4900~5850	0.1~0.15	61 +2/-1mm
5	Laird (G Type)	Gun main	PIFA	2.16(2.4G) 5.83(5G)	Hirose U.FL	2400~2500 4900~5850	0.1~0.15	25 ± 0.5mm
6	Laird (G Type)	Gun aux	PIFA	2.46(2.4G) 5.69(5G)	Hirose U.FL	2400~2500 4900~5850	0.1~0.15	61 +2/-1mm

Note :

1. For 2.4G: The antenna 6 was selected as representative antenna for the test.

2. For 5G: The antenna 5 was selected as representative antenna for the test.

For Bluetooth								
No.	Brand	Model	Antenna Type	Gain (dBi)	Connector Type	Frequency range (MHz)	Cable Loss(dB)	Cable Length
1	Motorola	Rot type	PIFA	3.08	Hirose U.FL	2400~2480	0.1~0.15	35 ± 0.5mm
2	Motorola	Str type	PIFA	2.481	Hirose U.FL	2400~2480	0.1~0.15	35 ± 0.5mm
3	Motorola	Gun type	PIFA	2.885	Hirose U.FL	2400~2480	0.1~0.15	35 ± 0.5mm



5 INFORMATION ON THE TESTING LABORATORIES

We, Bureau Veritas Consumer Products Services (H.K.) Ltd., Taoyuan Branch, were founded in 1988 to provide our best service in EMC, Radio, Telecom and Safety consultation. Our laboratories are accredited and approved by the following approval agencies according to ISO/IEC 17025:

USA	FCC, NVLAP
Germany	TUV Rheinland
Japan	VCCI
Norway	NEMKO
Canada	INDUSTRY CANADA, CSA
R.O.C.	TAF, BSMI, NCC
Netherlands	Telefication
Singapore	GOST-ASIA (MOU)
Russia	CERTIS (MOU)

Copies of accreditation certificates of our laboratories obtained from approval agencies can be downloaded from our web site: www.adt.com.tw/index.5/phtml.

If you have any comments, please feel free to contact us at the following:

Linko EMC/RF Lab:

Tel: 886-2-26052180

Fax: 886-2-26052943

Hsin Chu EMC/RF Lab:

Tel: 886-3-5935343

Fax: 886-3-5935342

Hwa Ya EMC/RF/Safety/Telecom Lab:

Tel: 886-3-3183232

Fax: 886-3-3185050

Email: service@adt.com.tw

Web Site: www.adt.com.tw

The address and road map of all our labs can be found in our web site also.

6 APPENDIX A - MODIFICATIONS RECORDERS FOR ENGINEERING CHANGES TO THE EUT BY THE LAB

No any modifications are made to the EUT by the lab during the test.

--- END ---