



A D T

SAR TEST REPORT (15.247)

REPORT NO.: SA980729H05

MODEL NO.: MC3190

RECEIVED: Jul. 29, 2009

TESTED: Sep. 02 ~ Sep. 08, 2009

ISSUED: Sep. 10, 2009

APPLICANT: Motorola Inc.

ADDRESS: One Motorola Plaza
Holtville NY 11742-1300
USA

ISSUED BY: Bureau Veritas Consumer Products Services
(H.K.) Ltd., Taoyuan Branch

LAB ADDRESS: No. 47, 14th Ling, Chia Pau Tsuen, Lin Kou
Hsiang, Taipei Hsien 244, Taiwan, R.O.C.

TEST LOCATION: No. 19, Hwa Ya 2nd Rd, Wen Hwa Tsuen, Kwei
Shan Hsiang, Taoyuan Hsien 333, Taiwan, R.O.C.

This test report consists of 45 pages in total except Appendix. It may be duplicated completely for legal use with the approval of the applicant. It should not be reproduced except in full, without the written approval of our laboratory. The client should not use it to claim product endorsement by TAF or any government agencies. The test results in the report only apply to the tested sample.





TABLE OF CONTENTS

1.	CERTIFICATION	3
2.	GENERAL INFORMATION	4
2.1	GENERAL DESCRIPTION OF EUT.....	4
2.2	GENERAL DESCRIPTION OF APPLIED STANDARDS.....	8
2.3	GENERAL INFORMATION OF THE SAR SYSTEM	9
2.4	GENERAL DESCRIPTION OF THE SPATIAL PEAK SAR EVALUATION	13
3.	DESCRIPTION OF SUPPORT UNITS.....	16
4.	DESCRIPTION OF TEST MODES AND CONFIGURATIONS.....	17
4.1.	DESCRIPTION OF TEST MODE.....	17
4.2.	SUMMARY OF TEST RESULTS.....	19
5.	TEST RESULTS	20
5.1	TEST PROCEDURES.....	20
5.2	MEASURED SAR RESULTS	22
5.3	SAR LIMITS	25
5.4	RECIPES FOR TISSUE SIMULATING LIQUIDS	26
5.5	TEST EQUIPMENT FOR TISSUE PROPERTY.....	32
6.	SYSTEM VALIDATION.....	33
6.1	TEST EQUIPMENT	33
6.2	TEST PROCEDURE	34
6.3	VALIDATION RESULTS	36
6.4	SYSTEM VALIDATION UNCERTAINTIES	37
7.	MEASUREMENT SAR PROCEDURE UNCERTAINTIES	38
7.1.	PROBE CALIBRATION UNCERTAINTY	38
7.2.	ISOTROPY UNCERTAINTY	39
7.3.	BOUNDARY EFFECT UNCERTAINTY	39
7.4.	PROBE LINEARITY UNCERTAINTY	40
7.5.	READOUT ELECTRONICS UNCERTAINTY.....	40
7.6.	RESPONSE TIME UNCERTAINTY	40
7.7.	INTEGRATION TIME UNCERTAINTY.....	41
7.8.	PROBE POSITIONER MECHANICAL TOLERANCE.....	42
7.9.	PROBE POSITIONING	42
7.10.	PHANTOM UNCERTAINTY.....	43
7.11.	DASY4 UNCERTAINTY BUDGET	44
8.	INFORMATION ON THE TESTING LABORATORIES.....	45

APPENDIX A: TEST CONFIGURATIONS AND TEST DATA

APPENDIX B: ADT SAR MEASUREMENT SYSTEM

APPENDIX C: PHOTOGRAPHS OF SYSTEM VALIDATION

APPENDIX D: SYSTEM CERTIFICATE & CALIBRATION



1. CERTIFICATION

PRODUCT: Mobile Computer
MODEL: MC3190
BRAND: MOTOROLA
APPLICANT: Motorola Inc.
TESTED: Sep. 02 ~ Sep. 08, 2009
TEST SAMPLE: ENGINEERING SAMPLE
STANDARDS: **FCC Part 2 (Section 2.1093)**
FCC OET Bulletin 65, Supplement C (01-01)
RSS-102 Issue 3 (June 2009)

The above equipment (model: MC3190) has been tested by **Bureau Veritas Consumer Products Services (H.K.) Ltd., Taoyuan Branch**, and found compliance with the requirement of the above standards. The test record, data evaluation & Equipment Under Test (EUT) configurations represented herein are true and accurate accounts of the measurements of the sample's EMC characteristics under the conditions specified in this report.

PREPARED BY : Andrea Hsia , **DATE** : Sep. 10, 2009
Andrea Hsia / Specialist

TECHNICAL ACCEPTANCE : James Fan , **DATE** : Sep. 10, 2009
Responsible for RF James Fan / Senior Engineer

APPROVED BY : Gary Chang , **DATE** : Sep. 10, 2009
Gary Chang / Assistant Manager



A D T

2. GENERAL INFORMATION

2.1 GENERAL DESCRIPTION OF EUT

PRODUCT	Mobile Computer	
MODEL NO.	MC3190	
FCC ID	UZ7MC3190	
POWER SUPPLY	DC 12V to cradle, DC 5.4V from power adapter or DC 3.7V from battery	
MODULATION TECHNOLOGY	DSSS, OFDM	
TRANSFER RATE	802.11b: 11 / 5.5 / 2 / 1Mbps 802.11g: 54 / 48 / 36 / 24 / 18 / 12 / 9 / 6Mbps 802.11a: 54 / 48 / 36 / 24 / 18 / 12 / 9 / 6Mbps	
OPERATING FREQUENCY	For 15.407: 5.18 ~ 5.32GHz, 5.50 ~ 5.70GHz For 15.247: 802.11b & 802.11g: 2412 ~ 2462MHz 802.11a: 5.745 ~ 5.825GHz	
NUMBER OF CHANNEL	For 15.407: 19 For 15.247: 11 for 802.11b, 802.11g 5 for 802.11a	
CHANNEL FREQUENCIES UNDER TEST AND ITS CONDUCTED OUTPUT POWER	802.11b (Main ant.)	802.11b (Aux. ant.)
	17.19dBm / Ch1: 2412MHz 17.11dBm / Ch6: 2437MHz 17.15dBm / Ch11: 2462MHz	17.17dBm / Ch1: 2412MHz 16.92dBm / Ch6: 2437MHz 16.95dBm / Ch11: 2462MHz
	802.11g (Main ant.)	802.11g (Aux. ant.)
	21.70dBm / Ch1: 2412MHz 22.20dBm / Ch6: 2437MHz 21.50dBm / Ch11: 2462MHz	21.14dBm / Ch1: 2412MHz 21.83dBm / Ch6: 2437MHz 21.09dBm / Ch11: 2462MHz
	802.11a (Main ant.)	802.11a (Aux. ant.)
	21.06dBm / Ch149: 5745MHz 20.80dBm / Ch157: 5785MHz 20.56dBm / Ch165: 5825MHz	20.87dBm / Ch149: 5745MHz 20.60dBm / Ch157: 5785MHz 20.27dBm / Ch165: 5825MHz
AVERAGE SAR (1g)	2.4GHz: 0.090W/kg 5.0GHz: 0.315W/kg	
ANTENNA TYPE	Please see note 4	
DATA CABLE	RS232 Cable x 1 (Part No.: 25-67866-03R) USB Cable x 1 (Part No.: 25-67868-03R) (only for test, not for sale together)	
I/O PORTS	USB port x 1, SD slot port x 1, Audio port x 1	
ASSOCIATED DEVICES	Battery x 1	

NOTE:

1. There are Bluetooth technology and WLAN technology used for the EUT. <the Bluetooth test data please refer "SA980729H05-2">
2. There are different types in MC3190, which with identical WLAN module and Bluetooth module in inside.



1. There are seven antennas provided to this EUT, please refer to the following table:

For WLAN								
No.	Brand	Model	Antenna Type	Gain (dBi)	Connector Type	Frequency range (MHz)	Cable Loss(dB)	Cable Length
1	Laird (R Type)	Rot main	PIFA	0.37(2.4G) 4.81(5G)	Hirose U.FL	2400~2850 4900~5850	0.1~0.15	25 ± 0.5mm
2	Laird (R Type)	Rot aux	PIFA	1.63(2.4G) 4.93(5G)	Hirose U.FL	2400~2850 4900~5850	0.1~0.15	61 +2/-1mm
3	Laird (S Type)	Str main	PIFA	0.89(2.4G) 4.34(5G)	Hirose U.FL	2400~2850 4900~5850	0.1~0.15	25 ± 0.5mm
4	Laird (S Type)	Str aux	PIFA	1.09(2.4G) 4.52(5G)	Hirose U.FL	2400~2850 4900~5850	0.1~0.15	61 +2/-1mm
5	Laird (G Type)	Gun main	PIFA	2.16(2.4G) 5.83(5G)	Hirose U.FL	2400~2850 4900~5850	0.1~0.15	25 ± 0.5mm
6	Laird (G Type)	Gun aux	PIFA	2.46(2.4G) 5.69(5G)	Hirose U.FL	2400~2850 4900~5850	0.1~0.15	61 +2/-1mm

Note :

1. For 2.4G: The antenna 6 was selected as representative antenna for the test.
2. For 5G: The antenna 5 was selected as representative antenna for the test.

For Bluetooth

No.	Brand	Model	Antenna Type	Gain (dBi)	Connector Type	Frequency range (MHz)	Cable Loss(dB)	Cable Length
1	Motorola	Rot type	PIFA	3.080	Hirose U.FL	2400~2480	0.1~0.15	35 ± 0.5mm
2	Motorola	Str type	PIFA	2.481	Hirose U.FL	2400~2480	0.1~0.15	35 ± 0.5mm
3	Motorola	Gun type	PIFA	2.885	Hirose U.FL	2400~2480	0.1~0.15	35 ± 0.5mm

2. For EUT with 3 working type and with different keypad & Scan Engine:

	Straight type			Gun Type			Rotating type		
	Keypad	48keys	38keys	28keys	48keys	38keys	28keys	48keys	38keys
Scan Engine	2D imaging	1D laser scanning	-	2D imaging	1D laser scanning	-	1D laser scanning		

**For the final test, worst case had been boldface.



A D T

3. The EUT could be supplied with the a charge, power adapter and Li-ion battery as below:

Cradle 1 (1-slot) (only for test, not for sale together)	
Brand:	SYMBOL
Part No.:	CRD3000-1001RR
Input power :	+12V----3.3A
I/O Ports:	USB Port x 1 RJ-45(console) Port x 1
Associated devices:	USB cable x 1 (Part No.: 25-68596-01R) (1.6m, Unshielded without core) RJ-45(console) cable x 1 (Part No.: 25-63852-01R) (1.8m, Unshielded without core) Adapter x 1 (Part No.: 50-14000-148R)
Cradle 2 (4-slot) (only for test, not for sale together)	
Brand:	SYMBOL
Part No.:	CRD3000-4001ER
Input power :	+12V----9A
I/O Ports:	RJ-45(LAN) Port x 2
Associated devices:	Power cable x 2 (Part No.: 50-16002-042R) (1.8m, Shielded with two cores) Adapter x 2 (Part No.: 50-14000-241R)
Adapter 1 (only for Cradle 1 use, not for sale together)	
Brand:	HIPRO
Model No.:	HP-O2040D43
Part No.:	50-14000-148R
Input power :	100-240V, 50-60Hz, 1.5A
Output power :	+12V----3.33A DC output cable (1.8m, Unshielded)
Adapter 2 (only for Cradle 2 use, not for sale together)	
Brand:	SYMBOL
Model No.:	SYM04-1
Part No.:	50-14000-241R
Input power :	100-120/200-240V, 50-60Hz, 3.0/1.5A
Output power :	+12V----9.0A



A D T

Adapter 1 (only for test, not for sale together)	
Brand:	DELTA
Model No.:	ADP-16GB A
Part No.:	50-14000-147
Input power :	100-240V, 50-60Hz, 0.4A
Output power :	+5.4V-----3.0A DC output cable (1.8m, Unshielded, with one core)
Adapter 2 (only for test, not for sale together)	
Brand:	MOTOROLA
Model No.:	EADP-16BB A
Part No.:	50-14000-249R
Input power :	100-240V, 50-60Hz, 0.4A
Output power :	+5.4V-----3.0A DC output cable (1.8m, Unshielded)
Li-ion Battery 1 for MC3190 (S & G)	
Brand:	MOTOROLA
Model No.:	82-127909-02
RATING:	3.7V, 4800mAh
Li-ion Battery 2 for MC3190(R)	
Brand:	MOTOROLA
Model No.:	82-127912-01
RATING:	3.7V, 2740mAh

3. The EUT operates in both the 5GHz and 2.4GHz Bands and compatibility with 802.11a, 802.11b, 802.11g and Bluetooth technology.
4. The above EUT information was declared by manufacturer and for more detailed features description, please refer to the manufacturer's specifications or user's manual.

2.2 GENERAL DESCRIPTION OF APPLIED STANDARDS

According to the specifications of the manufacturer, this product must comply with the requirements of the following standards:

FCC Part 2 (2.1093)

FCC OET Bulletin 65, Supplement C (01- 01)

RSS-102 Issue 3 (June 2009)

IEEE 1528-2003

All test items have been performed and recorded as per the above standards.

2.3 GENERAL INFORMATION OF THE SAR SYSTEM

DASY4 (**software 4.7 Build 80**) consists of high precision robot, probe alignment sensor, phantom, robot controller, controlled measurement server and near-field probe. The robot includes six axes that can move to the precision position of the DASY4 software defined. The DASY4 software can define the area that is detected by the probe. The robot is connected to controlled box. Controlled measurement server is connected to the controlled robot box. The DAE includes amplifier, signal multiplexing, AD converter, offset measurement and surface detection. It is connected to the Electro-optical coupler (ECO). The ECO performs the conversion from the optical into digital electric signal of the DAE and transfers data to the PC.

DASY5 (**software 5.0 Build 125**) consists of high precision robot, probe alignment sensor, phantom, robot controller, controlled measurement server and near-field probe. The robot includes six axes that can move to the precision position of the DASY5 software defined. The DASY5 software can define the area that is detected by the probe. The robot is connected to controlled box. Controlled measurement server is connected to the controlled robot box. The DAE includes amplifier, signal multiplexing, AD converter, offset measurement and surface detection. It is connected to the Electro-optical coupler (ECO). The ECO performs the conversion from the optical into digital electric signal of the DAE and transfers data to the PC.



A D T

EX3DV3 ISOTROPIC E-FIELD PROBE

CONSTRUCTION	Symmetrical design with triangular core Built-in shielding against static charges PEEK enclosure material (resistant to organic solvents, e.g., DGBE)
FREQUENCY	10 MHz to > 6 GHz Linearity: ± 0.2 dB (30 MHz to 6 GHz)
DIRECTIVITY	± 0.3 dB in HSL (rotation around probe axis) ± 0.5 dB in tissue material (rotation normal to probe axis)
DYNAMIC RANGE	10 μ W/g to > 100 mW/g Linearity: ± 0.2 dB (noise: typically < 1 μ W/g)
DIMENSIONS	Overall length: 330 mm (Tip: 20 mm) Tip diameter: 2.5 mm (Body: 12 mm) Typical distance from probe tip to dipole centers: 1 mm
APPLICATION	High precision dosimetric measurements in any exposure scenario (e.g., very strong gradient fields). Only probe which enables compliance testing for frequencies up to 6 GHz with precision of better 30%.

NOTE

1. The Probe parameters have been calibrated by the SPEAG. Please reference "APPENDIX D" for the Calibration Certification Report.
2. For frequencies above 800MHz, calibration in a rectangular wave-guide is used, because wave-guide size is manageable.
3. For frequencies below 800MHz, temperature transfer calibration is used because the wave-guide size becomes relatively large.

EX3DV4 ISOTROPIC E-FIELD PROBE

CONSTRUCTION	Symmetrical design with triangular core Built-in shielding against static charges PEEK enclosure material (resistant to organic solvents, e.g., DGBE)
FREQUENCY	10 MHz > 6 GHz Linearity: ± 0.2 dB (30 MHz to 6 GHz)
DIRECTIVITY	± 0.3 dB in HSL (rotation around probe axis) ± 0.5 dB in tissue material (rotation normal to probe axis)
DYNAMIC RANGE	10 μ W/g to > 100 mW/g Linearity: ± 0.2 dB (noise: typically < 1 μ W/g)
DIMENSIONS	Overall length: 330 mm (Tip: 20 mm) Tip diameter: 2.5 mm (Body: 12 mm) Typical distance from probe tip to dipole centers: 1 mm
APPLICATION	High precision dosimetric measurements in any exposure scenario (e.g., very strong gradient fields). Only probe which enables compliance testing for frequencies up to 6 GHz with precision of better 30%.

NOTE

1. The Probe parameters have been calibrated by the SPEAG. Please reference "APPENDIX D" for the Calibration Certification Report.
2. For frequencies above 800MHz, calibration in a rectangular wave-guide is used, because wave-guide size is manageable.
3. For frequencies below 800MHz, temperature transfer calibration is used because the wave-guide size becomes relatively large.



TWIN SAM V4.0

CONSTRUCTION

The shell corresponds to the specifications of the Specific Anthropomorphic Mannequin (SAM) phantom defined in IEEE 1528-2003, EN 62209-1 and IEC 62209. It enables the dosimetric evaluation of left and right hand phone usage as well as body mounted usage at the flat phantom region. A cover prevents evaporation of the liquid. Reference markings on the phantom allow the complete setup of all predefined phantom positions and measurement grids by manually teaching three points with the robot.

SHELL THICKNESS

2 ± 0.2mm

FILLING VOLUME

Approx. 25liters

DIMENSIONS

Height: 810mm; Length: 1000mm; Width: 500mm

SYSTEM VALIDATION KITS:

CONSTRUCTION

Symmetrical dipole with 1/4 balun enables measurement of feedpoint impedance with NWA matched for use near flat phantoms filled with brain simulating solutions. Includes distance holder and tripod adaptor

CALIBRATION

Calibrated SAR value for specified position and input power at the flat phantom in brain simulating solutions

FREQUENCY

2450MHz, 5800MHz

RETURN LOSS

> 20dB at specified validation position

POWER CAPABILITY

> 100W (f < 1GHz); > 40W (f > 1GHz)

OPTIONS

Dipoles for other frequencies or solutions and other calibration conditions upon request



DEVICE HOLDER FOR SAM TWIN PHANTOM

CONSTRUCTION

The device holder for the mobile phone device is designed to cope with different positions given in the standard. It has two scales for the device rotation (with respect to the body axis) and the device inclination (with respect to the line between the ear reference points). The rotation centers for both scales is the ear reference point (ERP). Thus the device needs no repositioning when changing the angles. The holder has been made out of low-loss POM material having the following dielectric parameters: relative permittivity $\varepsilon = 3$ and loss tangent $\delta = 0.02$. The amount of dielectric material has been reduced in the closest vicinity of the device, since measurements have suggested that the influence of the clamp on the test results could thus be lowered. The device holder for the portable device makes up of the polyethylene foam. The dielectric parameters of material close to the dielectric parameters of the air.

DATA ACQUISITION ELECTRONICS

CONSTRUCTION

The data acquisition electronics (DAE3) consists of a highly sensitive electrometer grade preamplifier with auto-zeroing, a channel and gain-switching multiplex, a fast 16 bit AD converter and a command decoder and control logic unit. Transmission to the measurement server is accomplished through an optical downlink for data and status information as well as an optical uplink for commands and the clock. The mechanical probe is mounting device includes two different sensor systems for frontal and sideways probe contacts. They are used for mechanical surface detection and probe collision detection. The input impedance of the DAE3 box is 200M Ω ; the inputs are symmetrical and floating. Common mode rejection is above 80 dB.



2.4 GENERAL DESCRIPTION OF THE SPATIAL PEAK SAR EVALUATION

The DASY4 post-processing software (SEMCAD) automatically executes the following procedures to calculate the field units from the micro-volt readings at the probe connector. The parameters used in the evaluation are stored in the configuration modules of the software:

Probe parameters:	- Sensitivity	Norm _i , a _{i0} , a _{i1} , a _{i2}
	- Conversion factor	ConvF _i
	- Diode compression point	dcp _i
Device parameters:	- Frequency	F
	- Crest factor	Cf
Media parameters:	- Conductivity	σ
	- Density	ρ

The first step of the evaluation is a linearization of the filtered input signal to account for the compression characteristics of the detector diode. The compensation depends on the input signal, the diode type and the DC-transmission factor from the diode to the evaluation electronics. If the exciting field is pulsed, the crest factor of the signal must be known to correctly compensate for peak power. The formula for each channel can be given as:

$$V_i = U_i + U_i^2 \cdot \frac{cf}{dcp_i}$$

V _i	=compensated signal of channel i	(i = x, y, z)
U _i	=input signal of channel I	(i = x, y, z)
Cf	=crest factor of exciting field	(DASY parameter)
dcp _i	=diode compression point	(DASY parameter)

From the compensated input signals the primary field data for each channel can be evaluated:

$$\text{E-field probes: } E_i = \sqrt{\frac{V_i}{\text{Norm}_i \cdot \text{ConvF}}}$$

$$\text{H-field probes: } H_i = \sqrt{V_i} \cdot \frac{a_{i0} + a_{i1}f + a_{i2}f^2}{f}$$

- V_i = compensated signal of channel i ($i = x, y, z$)
- Norm_i = sensor sensitivity of channel i $\mu\text{V}/(\text{V/m})^2$ for E-field Probes ($i = x, y, z$)
- ConvF = sensitivity enhancement in solution
- a_{ij} = sensor sensitivity factors for H-field probes
- f = carrier frequency [GHz]
- E_i = electric field strength of channel i in V/m
- H_i = magnetic field strength of channel i in A/m

The RSS value of the field components gives the total field strength (Hermitian magnitude):

$$E_{tot} = \sqrt{E_x^2 + E_y^2 + E_z^2}$$

The primary field data are used to calculate the derived field units.

$$SAR = E_{tot}^2 \cdot \frac{\sigma}{\rho \cdot 1'000}$$

- SAR = local specific absorption rate in mW/g
- E_{tot} = total field strength in V/m
- σ = conductivity in [mho/m] or [Siemens/m]
- ρ = equivalent tissue density in g/cm³

Note that the density is set to 1, to account for actual head tissue density rather than the density of the tissue simulating liquid. The entire evaluation of the spatial peak values is performed within the Post-processing engine (SEMCAD). The system always gives the maximum values for the 1g and 10g cubes. The algorithm to find the cube with highest averaged SAR is divided into the following stages:

1. The extraction of the measured data (grid and values) from the Zoom Scan
2. The calculation of the SAR value at every measurement point based on all stored data (A/D values and measurement parameters)
3. The generation of a high-resolution mesh within the measured volume
4. The interpolation of all measured values from the measurement grid to the high-resolution grid
5. The extrapolation of the entire 3-D field distribution to the phantom surface over the distance from sensor to surface
6. The calculation of the averaged SAR within masses of 1g and 10g.

The probe is calibrated at the center of the dipole sensors that is located 1 to 2.7mm away from the probe tip. During measurements, the probe stops shortly above the phantom surface, depending on the probe and the surface detecting system. Both distances are included as parameters in the probe configuration file. The software always knows exactly how far away the measured point is from the surface. As the probe cannot directly measure at the surface, the values between the deepest measured point and the surface must be extrapolated. The angle between the probe axis and the surface normal line is less than 30 degree.



The maximum search is automatically performed after each area scan measurement. It is based on splines in two or three dimensions. The procedure can find the maximum for most SAR distributions even with relatively large grid spacing. After the area scanning measurement, the probe is automatically moved to a position at the interpolated maximum. The following scan can directly use this position for reference, e.g., for a finer resolution grid or the cube evaluations. The 1g and 10g peak evaluations are only available for the predefined cube 7 x 7 x 7 scans. The routines are verified and optimized for the grid dimensions used in these cube measurements. The measured volume of 30 x 30 x 30mm contains about 30g of tissue. The first procedure is an extrapolation (incl. boundary correction) to get the points between the lowest measured plane and the surface. The next step uses 3D interpolation to get all points within the measured volume in a 1mm grid (42875 points). In the last step, a 1g cube is placed numerically into the volume and its averaged SAR is calculated. This cube is moved around until the highest averaged SAR is found. If the highest SAR is found at the edge of the measured volume, the system will issue a warning: higher SAR values might be found outside of the measured volume. In that case the cube measurement can be repeated, using the new interpolated maximum as the center.

3. DESCRIPTION OF SUPPORT UNITS

The EUT has been tested as an independent unit.

4. DESCRIPTION OF TEST MODES AND CONFIGURATIONS

4.1. DESCRIPTION OF TEST MODE

Test tool is CEcTxRx v1.5.0.0 provided by client. It can control EUT to transmit continuously at specific channel, output power level, data rates and 100 % duty signal.

“Per KDB 248277, for each frequency band, testing at higher data rates and higher order modulations is not required when the maximum average output power for each of these configurations is less than $\frac{1}{4}$ dB higher than those measured at the lowest data rate.”

Comparing output power of all modulations and data rates of each mode can find the lowest data rates has max output power. Therefore, EUT will set under lowest data rates to test.

“Per KDB 447498, when the SAR procedures require multiple channels to be tested and the 1-g SAR for the highest output channel is less than 0.8 W/kg and peak SAR is less than 1.6W/kg, where the transmission band corresponding to all channels is \leq 100 MHz, testing for the other channels is not required.”

According to test data from table of section 4.2, SAR value of highest output power channel is less than 0.8 W / kg and peak SAR is less than 1.6W/kg. Therefore, testing for other channels is not required.



A D T

ITEM	TEST MODE	MODULATION	EUT TYPE	ASSESSMENT POSTITION	KEYPAD	TESTED CHANNEL	TX ANTENNA
1	802.11g	BPSK	A	Body / Back with leather & 1D scan engine	28Keys	6	Main
2	802.11g	BPSK		Body / Back with leather & 1D scan engine	28Keys	6	Aux.
3	802.11g	BPSK		Body / Front with leather & 1D scan engine	28Keys	6	Main
4	802.11g	BPSK		Body / Front with leather & 1D scan engine	28Keys	6	Aux.
5	802.11b	DBPSK		Body / Back with leather & 1D scan engine	28Keys	1	Main
6	802.11a	BPSK		Body / Back with leather & 1D scan engine	28Keys	149	Main
7	802.11g	BPSK	B	Body / Back with leather & 1D scan engine	28Keys	6	Main
8	802.11g	BPSK		Body / Back with leather & 1D scan engine	28Keys	6	Aux.
9	802.11g	BPSK		Body / Back with leather & 2D scan engine	28Keys	6	Main
10	802.11b	DBPSK		Body / Back with leather & 1D scan engine	28Keys	1	Main
11	802.11a	BPSK		Body / Back with leather & 1D scan engine	28Keys	149	Main
12	802.11b	BPSK	C	Body / Left with leather & 1D scan engine	28Keys	1	Main
13	802.11g	BPSK		Body / Left with leather & 1D scan engine	28Keys	6	Main
14	802.11g	BPSK		Body / Right with leather & 1D scan engine	28Keys	6	Aux.
15	802.11g	BPSK		Body / Left with leather & 2D scan engine	28Keys	6	Main
16	802.11g	DBPSK		Body / Right with leather & 1D scan engine	28Keys	149	Aux.

NOTE: EUT Type A: Rotate type, B: Straight type, C: Body Gun Type; please refer to the test set up photo.



4.2. SUMMARY OF TEST RESULTS

ITEM		1	2	3	4	5	ITEM		6
TEST MODE		802.11g				802.11b	TEST MODE		802.11a
CHAN.	FREQ. (MHz)	MEASURED VALUE OF 1g SAR (W/kg)					CHAN.	FREQ. (MHz)	MEASURED VALUE OF 1g SAR (W/kg)
1	2412 (Low)	-	-	-	-	0.036	149	5745	0.102
6	2437 (Mid.)	0.052	0.019	0.00982	0.013	-			

ITEM		7	8	9	10	ITEM		11	
TEST MODE		802.11g				802.11b	TEST MODE		802.11a
CHAN.	FREQ. (MHz)	MEASURED VALUE OF 1g SAR (W/kg)					CHAN.	FREQ. (MHz)	MEASURED VALUE OF 1g SAR (W/kg)
1	2412 (Low)	-	-	-	0.075	149	5745	0.061	
6	2437 (Mid.)	0.090	0.032	0.082	-				

ITEM		12	13	14	15	ITEM		16	
TEST MODE		802.11b	802.11g			TEST MODE		802.11a	
CHAN.	FREQ. (MHz)	MEASURED VALUE OF 1g SAR (W/kg)					CHAN.	FREQ. (MHz)	MEASURED VALUE OF 1g SAR (W/kg)
1	2412 (Low)	0.050	-	-	-	149	5745	0.315	
6	2437 (Mid.)	-	0.058	0.011	0.050				

NOTE: The worst value has been marked by boldface.

5. TEST RESULTS

5.1 TEST PROCEDURES

Use the software to control the EUT channel and transmission power. Then record the conducted power before the testing. Place the EUT to the specific test location. After the testing, must writing down the conducted power of the EUT into the report. The SAR value was calculated via the 3D spline interpolation algorithm that has been implemented in the software of DASY4 SAR measurement system manufactured and calibrated by SPEAG. According to the IEEE 1528 standards, the recommended procedure for assessing the peak spatial-average SAR value consists of the following steps:

- Power reference measurement
- Verification of the power reference measurement
- Area scan
- Zoom scan
- Power reference measurement

The area scan was performed for the highest spatial SAR location. The zoom scan with 30mm x 30mm x 30mm volume was performed for SAR value averaged over 1g and 10g spatial volumes.

In the zoom scan, the distance between the measurement point at the probe sensor location (geometric center behind the probe tip) and the phantom surface is 3mm and maintained at a constant distance of ± 0.5 mm during a zoom scan to determine peak SAR locations. The distance is 3mm between the first measurement point and the bottom surface of the phantom. The secondary measurement point to the bottom surface of the phantom is with 8mm separation distance. The cube size is 7 x 7 x 7 points consists of 343 points and the grid space is 5mm.



A D T

The measurement time is 0.5s at each point of the zoom scan. The probe boundary effect compensation shall be applied during the SAR test. Because of the tip of the probe to the Phantom surface separated distances are longer than half a tip probe diameter.

In the area scan, the separation distance is 3mm between the each measurement point and the phantom surface. The scan size shall be included the transmission portion of the EUT. The measurement time is the same as the zoom scan. At last the reference power drift shall be less than $\pm 5\%$.

**5.2 MEASURED SAR RESULTS**

ENVIRONMENTAL CONDITION		Air Temperature : 22.8°C, Liquid Temperature : 21.9°C Humidity : 60%RH				
TESTED BY		Sam Onn	DATE		Sep. 02, 2009	
CHAN.	FREQ. (MHz)	TEST MODE	CONDUCTED POWER (dBm)	POWER DRIFT (dB)	DEVICE TEST POSITION MODE	MEASURED 1g SAR (W/kg)
			BEGIN TEST			
6	2437 (Mid.)	802.11g	22.20	-0.086	1	0.052
6	2437 (Mid.)	802.11g	21.83	0.094	2	0.019
6	2437 (Mid.)	802.11g	22.20	0.147	3	0.00982
6	2437 (Mid.)	802.11g	21.83	-0.001	4	0.013
1	2412 (Low)	802.11b	17.19	-0.131	5	0.036

NOTE:

1. Test configuration of each mode is described in section 4.
2. In this testing, the limit for General Population Spatial Peak averaged over 1g, **1.6 W/kg**, is applied.
3. Please see the Appendix A for the data.
4. The variation of the EUT conducted power measured before and after SAR testing should not over 5%.

ENVIRONMENTAL CONDITION		Air Temperature : 22.7°C, Liquid Temperature : 22.0°C Humidity : 60%RH				
TESTED BY		Sam Onn	DATE		Sep. 04, 2009	
CHAN.	FREQ. (MHz)	TEST MODE	CONDUCTED POWER (dBm)	POWER DRIFT (dB)	DEVICE TEST POSITION MODE	MEASURED 1g SAR (W/kg)
			BEGIN TEST			
149	5745	802.11a	21.06	0.046	6	0.102

NOTE:

1. Test configuration of each mode is described in section 4.
2. In this testing, the limit for General Population Spatial Peak averaged over 1g, **1.6 W/kg**, is applied.
3. Please see the Appendix A for the data.
4. The variation of the EUT conducted power measured before and after SAR testing should not over 5%.



A D T

ENVIRONMENTAL CONDITION			Air Temperature : 23.0°C, Liquid Temperature : 21.8°C Humidity : 59%RH			
TESTED BY			Sam Onn	DATE		Sep. 03, 2009
CHAN.	FREQ. (MHz)	TEST MODE	CONDUCTED POWER (dBm)	POWER DRIFT (dB)	DEVICE TEST POSITION MODE	MEASURED 1g SAR (W/kg)
			BEGIN TEST			
6	2437 (Mid.)	802.11g	22.20	-0.061	7	0.090
6	2437 (Mid.)	802.11g	21.83	-0.037	8	0.032
6	2437 (Mid.)	802.11g	22.20	-0.023	9	0.082
1	2412 (Low)	802.11b	17.19	-0.006	10	0.075

NOTE:

1. Test configuration of each mode is described in section 4.
2. In this testing, the limit for General Population Spatial Peak averaged over 1g, **1.6 W/kg**, is applied.
3. Please see the Appendix A for the data.
4. The variation of the EUT conducted power measured before and after SAR testing should not over 5%.

ENVIRONMENTAL CONDITION			Air Temperature : 23.1°C, Liquid Temperature : 22.0°C Humidity : 58%RH			
TESTED BY			Sam Onn	DATE		Sep. 05, 2009
CHAN.	FREQ. (MHz)	TEST MODE	CONDUCTED POWER (dBm)	POWER DRIFT (dB)	DEVICE TEST POSITION MODE	MEASURED 1g SAR (W/kg)
			BEGIN TEST			
149	5745	802.11a	21.06	0.074	11	0.061

NOTE:

1. Test configuration of each mode is described in section 4.
2. In this testing, the limit for General Population Spatial Peak averaged over 1g, **1.6 W/kg**, is applied.
3. Please see the Appendix A for the data.
4. The variation of the EUT conducted power measured before and after SAR testing should not over 5%.



A D T

ENVIRONMENTAL CONDITION		Air Temperature : 23.2°C, Liquid Temperature : 22.7°C Humidity : 64%RH					
TESTED BY		Sam Onn		DATE		Sep. 07, 2009	
CHAN.	FREQ. (MHz)	TEST MODE	CONDUCTED POWER (dBm)		POWER DRIFT (dB)	DEVICE TEST POSITION MODE	MEASURED 1g SAR (W/kg)
			BEGIN TEST				
1	2412 (Low)	802.11b	17.19		-0.126	12	0.050
6	2437 (Mid.)	802.11g	22.20		-0.146	13	0.058
6	2437 (Mid.)	802.11g	21.83		-0.101	14	0.011
6	2437 (Mid.)	802.11g	22.20		-0.150	15	0.050

NOTE:

1. Test configuration of each mode is described in section 4.
2. In this testing, the limit for General Population Spatial Peak averaged over 1g, **1.6 W/kg**, is applied.
3. Please see the Appendix A for the data.
4. The variation of the EUT conducted power measured before and after SAR testing should not over 5%.

ENVIRONMENTAL CONDITION		Air Temperature : 23.1°C, Liquid Temperature : 22.6°C Humidity : 61%RH					
TESTED BY		Sam Onn		DATE		Sep. 08, 2009	
CHAN.	FREQ. (MHz)	TEST MODE	CONDUCTED POWER (dBm)		POWER DRIFT (dB)	DEVICE TEST POSITION MODE	MEASURED 1g SAR (W/kg)
			BEGIN TEST				
149	5745	802.11a	20.87		-0.149	16	0.315

NOTE:

1. Test configuration of each mode is described in section 4.
2. In this testing, the limit for General Population Spatial Peak averaged over 1g, **1.6 W/kg**, is applied.
3. Please see the Appendix A for the data.
4. The variation of the EUT conducted power measured before and after SAR testing should not over 5%.



5.3 SAR LIMITS

HUMAN EXPOSURE	SAR (W/kg)	
	(GENERAL POPULATION / UNCONTROLLED EXPOSURE ENVIRONMENT)	(OCCUPATIONAL / CONTROLLED EXPOSURE ENVIRONMENT)
Spatial Average (whole body)	0.08	0.4
Spatial Peak (averaged over 1 g)	1.6	8.0
Spatial Peak (hands / wrists / feet / ankles averaged over 10 g)	4.0	20.0

NOTE:

1. This limits accord to 47 CFR 2.1093 – Safety Limit.
2. The EUT property been complied with the partial body exposure limit under the general population environment.

5.4 RECIPES FOR TISSUE SIMULATING LIQUIDS

For the measurement of the field distribution inside the SAM phantom, the phantom must be filled with 25 liters of tissue simulation liquid.

The following ingredients are used :

- **WATER-** Deionized water (pure H₂O), resistivity ≥ 16 M - as basis for the liquid
- **SUGAR-** Refined sugar in crystals, as available in food shops - to reduce relative permittivity
- **SALT-** Pure NaCl - to increase conductivity
- **CELLULOSE-** Hydroxyethyl-cellulose, medium viscosity (75-125mPa.s, 2% in water, 20_C),
CAS # 54290 - to increase viscosity and to keep sugar in solution
- **PRESERVATIVE-** Preventol D-7 Bayer AG, D-51368 Leverkusen, CAS # 55965-84-9 - to prevent the spread of bacteria and molds
- **DGMBE-** Diethylenglycol-monobuthyl ether (DGMBE), Fluka Chemie GmbH, CAS # 112-34-5 - to reduce relative permittivity



A D T

THE RECIPES FOR 2450MHz SIMULATING LIQUID TABLE

INGREDIENT	HEAD SIMULATING LIQUID 2450MHz (HSL-2450)	MUSCLE SIMULATING LIQUID 2450MHz (MSL-2450)
Water	45%	69.83%
DGMBE	55%	30.17%
Salt	NA	NA
Dielectric Parameters at 22°C	f= 2450MHz $\epsilon = 39.2 \pm 5\%$ $\sigma = 1.80 \pm 5\%$ S/m	f= 2450MHz $\epsilon = 52.7 \pm 5\%$ $\sigma = 1.95 \pm 5\%$ S/m

THE INFORMATION FOR 5GHz SIMULATING LIQUID

The 5GHz liquids was purchased from SPEAG.

Body liquid model: HSL 5800, P/N: SL AAH 5800 AA

Head liquid model: M 5800, P/N: SL AAM 580 AD

5GHz liquids contain the following ingredients:

Water 64 - 78%

Mineral Oil 11 - 18%

Emulsifiers 9 - 15%

Additives and Salt 2 - 3%



Testing the liquids using the Agilent Network Analyzer E8358A and Agilent Dielectric Probe Kit 85070D. The testing procedure is following as

1. Turn Network Analyzer on and allow at least 30min. warm up.
2. Mount dielectric probe kit so that interconnecting cable to Network Analyzer will not be moved during measurements or calibration.
3. Pour de-ionized water and measure water temperature ($\pm 1^\circ$).
4. Set water temperature in Agilent-Software (Calibration Setup).
5. Perform calibration.
6. Validate calibration with dielectric material of known properties (e.g. polished ceramic slab with $>8\text{mm}$ thickness $\epsilon' = 10.0$, $\epsilon'' = 0.0$). If measured parameters do not fit within tolerance, repeat calibration (± 0.2 for ϵ' : ± 0.1 for ϵ'').
7. Conductivity can be calculated from ϵ'' by $\sigma = \omega \epsilon_0 \epsilon'' = \epsilon'' f [\text{GHz}] / 18$.
8. Measure liquid shortly after calibration. Repeat calibration every hour.
9. Stir the liquid to be measured. Take a sample ($\sim 50\text{ml}$) with a syringe from the center of the liquid container.
10. Pour the liquid into a small glass flask. Hold the syringe at the bottom of the flask to avoid air bubbles.
11. Put the dielectric probe in the glass flask. Check that there are no air bubbles in front of the opening in the dielectric probe kit.
12. Perform measurements.
13. Adjust medium parameters in DASY4 for the frequencies necessary for the measurements ('Setup Config', select medium (e.g. Brain 900MHz) and press 'Option'-button.
14. Select the current medium for the frequency of the validation (e.g. Setup Medium Brain 900MHz).



A D T

FOR 2.4GHz BAND SIMULATING LIQUID

LIQUID TYPE		MSL-2450		
SIMULATING LIQUID TEMP.		21.9		
TEST DATE		Sep. 02, 2009		
TESTED BY		Sam Onn		
FREQ. (MHz)	LIQUID PARAMETER	STANDARD VALUE	MEASUREMENT VALUE	ERROR PERCENTAGE (%)
2412.0	Permittivity (ϵ)	52.80	53.80	1.89
2437.0		52.70	53.70	1.90
2450.0		52.70	53.70	1.90
2412.0	Conductivity (σ) S/m	1.91	1.88	-1.57
2437.0		1.94	1.92	-1.03
2450.0		1.95	1.94	-0.51
Dielectric Parameters Required at 22°C		f= 2450MHz $\epsilon= 52.7 \pm 5\%$ $\sigma= 1.95 \pm 5\%$ S/m		

LIQUID TYPE		MSL-2450		
SIMULATING LIQUID TEMP.		21.8		
TEST DATE		Sep. 03, 2009		
TESTED BY		Sam Onn		
FREQ. (MHz)	LIQUID PARAMETER	STANDARD VALUE	MEASUREMENT VALUE	ERROR PERCENTAGE (%)
2412.0	Permittivity (ϵ)	52.80	54.10	2.46
2437.0		52.70	54.00	2.47
2450.0		52.70	54.00	2.47
2412.0	Conductivity (σ) S/m	1.91	1.9	-0.52
2437.0		1.94	1.94	0.00
2450.0		1.95	1.96	0.51
Dielectric Parameters Required at 22°C		f= 2450MHz $\epsilon= 52.7 \pm 5\%$ $\sigma= 1.95 \pm 5\%$ S/m		



A D T

LIQUID TYPE		MSL-2450		
SIMULATING LIQUID TEMP.		22.7		
TEST DATE		Sep. 07, 2009		
TESTED BY		Dylan Chiou		
FREQ. (MHz)	LIQUID PARAMETER	STANDARD VALUE	MEASUREMENT VALUE	ERROR PERCENTAGE (%)
2412.0	Permittivity (ϵ)	52.80	55.00	4.17
2437.0		52.70	54.90	4.17
2450.0		52.70	54.80	3.98
2462.0		52.70	54.70	3.80
2412.0	Conductivity (σ) S/m	1.91	1.96	2.62
2437.0		1.94	1.99	2.58
2450.0		1.97	2.01	2.03
2462.0		1.97	2.02	2.54
Dielectric Parameters Required at 22°C		f= 2450MHz $\epsilon= 52.7 \pm 5\%$ $\sigma= 1.95 \pm 5\%$ S/m		

FOR WLAN 5GHz BAND SIMULATING LIQUID

LIQUID TYPE		MSL-5800		
SIMULATING LIQUID TEMP.		22.0		
TEST DATE		Sep. 04, 2009		
TESTED BY		Sam Onn		
FREQ. (MHz)	LIQUID PARAMETER	STANDARD VALUE	MEASUREMENT VALUE	ERROR PERCENTAGE (%)
5745.0	Permittivity (ϵ)	48.30	48.80	1.04
5800.0		48.20	48.80	1.24
5745.0	Conductivity (σ) S/m	5.94	6.03	1.52
5800.0		6.00	6.10	1.67
Dielectric Parameters Required at 22°C		f= 2450MHz $\epsilon= 52.7 \pm 5\%$ $\sigma= 1.95 \pm 5\%$ S/m		



A D T

LIQUID TYPE		MSL-5800		
SIMULATING LIQUID TEMP.		22.0		
TEST DATE		Sep. 05, 2009		
TESTED BY		Sam Onn		
FREQ. (MHz)	LIQUID PARAMETER	STANDARD VALUE	MEASUREMENT VALUE	ERROR PERCENTAGE (%)
5745.0	Permittivity (ϵ)	48.30	49.40	2.28
5800.0		48.20	49.30	2.28
5745.0	Conductivity (σ) S/m	5.94	5.99	0.84
5800.0		6.00	6.08	1.33
Dielectric Parameters Required at 22°C		f= 2450MHz $\epsilon= 52.7 \pm 5\%$ $\sigma= 1.95 \pm 5\% \text{ S/m}$		

LIQUID TYPE		MSL-5800		
SIMULATING LIQUID TEMP.		22.6		
TEST DATE		Sep. 08, 2009		
TESTED BY		Dylan Chiou		
FREQ. (MHz)	LIQUID PARAMETER	STANDARD VALUE	MEASUREMENT VALUE	ERROR PERCENTAGE (%)
5745.0	Permittivity (ϵ)	48.30	50.10	3.73
5800.0		48.20	50.00	3.73
5745.0	Conductivity (σ) S/m	5.94	6.19	4.21
5800.0		6.0	6.26	4.33
Dielectric Parameters Required at 22°C		f= 2450MHz $\epsilon= 52.7 \pm 5\%$ $\sigma= 1.95 \pm 5\% \text{ S/m}$		



5.5 TEST EQUIPMENT FOR TISSUE PROPERTY

ITEM	NAME	BRAND	TYPE	SERIES NO.	DATE OF CALIBRATION	DUE DATE OF CALIBRATION
1	Network Analyzer	Agilent	E8358A	US41480538	Nov. 27, 2008	Nov. 26, 2009
2	Dielectric Probe	Agilent	85070D	US01440176	NA	NA

NOTE:

1. Before starting, all test equipment shall be warmed up for 30min.
2. The tolerance (k=1) specified by Agilent for general dielectric measurements, deriving from inaccuracies in the calibration data, analyzer drift, and random errors, are usually $\pm 2.5\%$ and $\pm 5\%$ for measured permittivity and conductivity, respectively. However, the tolerances for the conductivity is smaller for material with large loss tangents, i.e., less than $\pm 2.5\%$ (k=1). It can be substantially smaller if more accurate methods are applied.



6. SYSTEM VALIDATION

The system validation was performed in the flat phantom with equipment listed in the following table. Since the SAR value is calculated from the measured electric field, dielectric constant and conductivity of the body tissue and the SAR is proportional to the square of the electric field. So, the SAR value will be also proportional to the RF power input to the system validation dipole under the same test environment. In our system validation test, 250mW RF input power was used.

6.1 TEST EQUIPMENT

ITEM	NAME	BRAND	TYPE	SERIES NO.	DATE OF CALIBRATION	DUE DATE OF CALIBRATION
1	SAM Phantom	S & P	QD000 P40 CA	TP-1150	NA	NA
2	Signal Generator	Anritsu	68247B	984703	May 21, 2009	May 20, 2010
3	E-Field Probe	S & P	EX3DV3	3504	Jan. 21, 2009	Jan. 20, 2010
4			EX3DV4	3590	Apr. 28, 2009	Apr. 27, 2010
5	DAE	S & P	DAE	861	Sep. 22, 2008	Sep. 21, 2009
6				510	Jan. 21, 2009	Jan. 20, 2010
7	Robot Positioner	Staubli Unimation	NA	NA	NA	NA
8	Validation Dipole	S & P	D2450V2	716	Mar. 17, 2009	Mar. 16, 2010
9			D5GHzV2	1019	Feb. 20, 2009	Feb. 19, 2010

NOTE: Before starting the measurement, all test equipment shall be warmed up for 30min.

6.2 TEST PROCEDURE

Before the system performance check, we need only to tell the system which components (probe, medium, and device) are used for the system performance check; the system will take care of all parameters. The dipole must be placed beneath the flat section of the SAM Twin Phantom with the correct distance holder in place. The distance holder should touch the phantom surface with a light pressure at the reference marking (little cross) and be oriented parallel to the long side of the phantom. Accurate positioning is not necessary, since the system will search for the peak SAR location, except that the dipole arms should be parallel to the surface. The device holder for mobile phones can be left in place but should be rotated away from the dipole.

1. The "Power Reference Measurement" and "Power Drift Measurement" jobs are located at the beginning and end of the batch process. They measure the field drift at one single point in the liquid over the complete procedure. The indicated drift is mainly the variation of the amplifier output power. If it is too high (above ± 0.1 dB), the system performance check should be repeated; some amplifiers have very high drift during warm-up. A stable amplifier gives drift results in the DASY system below ± 0.02 dB.
2. The "Surface Check" job tests the optical surface detection system of the DASY system by repeatedly detecting the surface with the optical and mechanical surface detector and comparing the results. The output gives the detecting heights of both systems, the difference between the two systems and the standard deviation of the detection repeatability. Air bubbles or refraction in the liquid due to separation of the sugar-water mixture gives poor repeatability (above ± 0.1 mm). In that case it is better to abort the system performance check and stir the liquid.



3. The "Area Scan" job measures the SAR above the dipole on a plane parallel to the surface. It is used to locate the approximate location of the peak SAR. The proposed scan uses large grid spacing for faster measurement; due to the symmetric field, the peak detection is reliable. If a finer graphic is desired, the grid spacing can be reduced. Grid spacing and orientation have no influence on the SAR result.
4. The "Zoom Scan" job measures the field in a volume around the peak SAR value assessed in the previous "Area Scan" job (for more information see the application note on SAR evaluation).

About the validation dipole positioning uncertainty, the constant and low loss dielectric spacer is used to establish the correct distance between the top surface of the dipole and the bottom surface of the phantom, the error component introduced by the uncertainty of the distance between the liquid (i.e., phantom shell) and the validation dipole in the DASYS4 system is less than ± 0.1 mm.

$$SAR_{tolerance} [\%] = 100 \times \left(\frac{(a + d)^2}{a^2} - 1 \right)$$

As the closest distance is 10mm, the resulting tolerance $SAR_{tolerance}[\%]$ is <2%.



6.3 VALIDATION RESULTS

SYSTEM VALIDATION TEST OF SIMULATING LIQUID					
FREQUENCY (MHz)	REQUIRED SAR (mW/g)	MEASURED SAR (mW/g)	DEVIATION (%)	SEPARATION DISTANCE	TESTED DATE
MSL2450	13.30 (1g)	12.60	-5.26	10mm	Sep. 02, 2009
MSL2450	13.30 (1g)	12.40	-6.77	10mm	Sep. 03, 2009
MSL2450	13.30 (1g)	13.80	3.76	10mm	Sep. 07, 2009
MSL5800	7.31 (1g)	7.19	-1.64	10mm	Sep. 04, 2009
MSL5800	7.31 (1g)	7.22	-1.23	10mm	Sep. 05, 2009
MSL5800	7.31 (1g)	7.61	4.10	10mm	Sep. 08, 2009
TESTED BY	Sam Onn				

NOTE: Please see Appendix for the photo of system validation test.

6.4 SYSTEM VALIDATION UNCERTAINTIES

In the table below, the system validation uncertainty with respect to the analytically assessed SAR value of a dipole source as given in the IEEE 1528 standard is given. This uncertainty is smaller than the expected uncertainty for mobile phone measurements due to the simplified setup and the symmetric field distribution.

Error Description	Tolerance (±%)	Probability Distribution	Divisor	(C _i)		Standard Uncertainty (±%)		(v _i)
				(1g)	(10g)	(1g)	(10g)	
Measurement System								
Probe Calibration	6.55	Normal	1	1	1	6.55	6.55	∞
Axial Isotropy	4.70	Rectangular	$\sqrt{3}$	0.7	0.7	1.90	1.90	∞
Hemispherical Isotropy	9.60	Rectangular	$\sqrt{3}$	0.7	0.7	3.88	3.88	∞
Boundary effects	2.00	Rectangular	$\sqrt{3}$	1	1	1.15	1.15	∞
Linearity	4.70	Rectangular	$\sqrt{3}$	1	1	2.71	2.71	∞
System Detection Limits	1.00	Rectangular	$\sqrt{3}$	1	1	0.58	0.58	∞
Readout Electronics	0.30	Normal	1	1	1	0.30	0.30	∞
Response Time	0.80	Rectangular	$\sqrt{3}$	1	1	0.46	0.46	∞
Integration Time	2.60	Rectangular	$\sqrt{3}$	1	1	1.50	1.50	∞
RF Ambient Noise	3.00	Rectangular	$\sqrt{3}$	1	1	1.73	1.73	∞
RF Ambient Reflections	3.00	Rectangular	$\sqrt{3}$	1	1	1.73	1.73	∞
Probe Positioner	0.80	Rectangular	$\sqrt{3}$	1	1	0.46	0.46	∞
Probe Positioning	9.90	Rectangular	$\sqrt{3}$	1	1	5.72	5.72	∞
Max. SAR Eval.	4.00	Rectangular	$\sqrt{3}$	1	1	2.31	2.31	∞
Dipole Related								
Dipole Axis to Liquid Distance	2.00	Rectangular	$\sqrt{3}$	1	1	1.15	1.15	145
Input Power Drift	5.00	Rectangular	$\sqrt{3}$	1	1	2.89	2.89	∞
Phantom and Tissue parameters								
Phantom Uncertainty	4.00	Rectangular	$\sqrt{3}$	1	1	2.31	2.31	∞
Liquid Conductivity (target)	5.00	Rectangular	$\sqrt{3}$	0.64	0.43	1.85	1.24	∞
Liquid Conductivity (measurement)	4.91	Normal	1	0.64	0.43	3.14	2.11	∞
Liquid Permittivity (target)	5.00	Rectangular	$\sqrt{3}$	0.6	0.49	1.73	1.41	∞
Liquid Permittivity (measurement)	4.24	Normal	1	0.6	0.49	2.54	2.08	∞
Combined Standard Uncertainty						12.45	12.03	
Coverage Factor for 95%						Kp=2		
Expanded Uncertainty (K=2)						24.91	24.06	

NOTE: About the system validation uncertainty assessment, please reference the section 7.

7. MEASUREMENT SAR PROCEDURE UNCERTAINTIES

The assessment of spatial peak SAR of the hand handheld devices is according to IEEE 1528 / EN 62209-1. All testing situation shall be met below these requirements.

- The system is used by an experienced engineer who follows the manual and the guidelines taught during the training provided by SPEAG.
- The probe has been calibrated within the requested period and the stated uncertainty for the relevant frequency bands does not exceed 4.8% (k=1).
- The validation dipole has been calibrated within the requested period and the system performance check has been successful.
- The DAE unit has been calibrated within the within the requested period.
- The minimum distance between the probe sensor and inner phantom shell is selected to be between 4 and 5mm.
- The operational mode of the DUT is CW, CDMA, FDMA or TDMA (GSM, DCS, PCS, IS136 and PDC) and the measurement/integration time per point is >500 ms.
- The dielectric parameters of the liquid have been assessed using Agilent 85070D dielectric probe kit or a more accurate method.
- The dielectric parameters are within 5% of the target values.
- The DUT has been positioned as described in section 3.

7.1. PROBE CALIBRATION UNCERTAINTY

SPEAG conducts the probe calibration in compliance with international and national standards (e.g. IEEE 1528, EN 62209-1, IEC 62209, etc.) under ISO17025. The uncertainties are stated on the calibration certificate. For the most relevant frequency bands, these values do not exceed 4.8% (k=1). If evaluations of other bands are performed for which the uncertainty exceeds these values, the uncertainty tables given in the summary have to be revised accordingly.

7.2. ISOTROPY UNCERTAINTY

The axial isotropy tolerance accounts for probe rotation around its axis while the hemispherical isotropy error includes all probe orientations and field polarizations. These parameters are assessed by SPEAG during initial calibration. In 2001, SPEAG further tightened its quality controls and warrants that the maximal deviation from axial isotropy is $\pm 0.20\text{dB}$, while the maximum deviation of hemispherical isotropy is $\pm 0.40\text{dB}$, corresponding to $\pm 4.7\%$ and $\pm 9.6\%$, respectively. A weighting factor of c_p equal to 0.5 can be applied, since the axis of the probe deviates less than 30 degrees from the normal surface orientation.

7.3. BOUNDARY EFFECT UNCERTAINTY

The effect can be estimated according to the following error approximation formula

$$SAR_{tolerance} [\%] = SAR_{be} [\%] \times \frac{(d_{be} + d_{step})^2}{2d_{step}} \frac{e^{-\frac{d_{be}}{\delta/2}}}{\delta/2}$$

$$d_{be} + d_{step} < 10\text{mm}$$

The parameter d_{be} is the distance in mm between the surface and the closest measurement point used in the averaging process; d_{step} is the separation distance in mm between the first and second measurement points; δ is the minimum penetration depth in mm within the head tissue equivalent liquids (i.e., $\delta = 13.95\text{mm}$ at 3GHz); SAR_{be} is the deviation between the measured SAR value at the distance d_{be} from the boundary and the wave-guide analytical value SAR_{ref} . DAS4 applies a boundary effect compensation algorithm according to IEEE 1528, which is possible since the axis of the probe never deviates more than 30 degrees from the normal surface orientation. $SAR_{be} [\%]$ is assessed during the calibration process and SPEAG warrants that the uncertainty at distances larger than 4mm is always less than 1%. In summary, the worst case boundary effect SAR tolerance [%] for scanning distances larger than 4mm is $< \pm 0.8\%$.

7.4. PROBE LINEARITY UNCERTAINTY

Field probe linearity uncertainty includes errors from the assessment and compensation of the diode compression effects for CW and pulsed signals with known duty cycles. This error is assessed using the procedure described in IEEE 1528 / EN 62209-1. For SPEAG field probes, the measured difference between CW and pulsed signals, with pulse frequencies between 10Hz and 1kHz and duty cycles between 1 and 100, is $< \pm 0.20\text{dB}$ ($< \pm 4.7\%$).

7.5. READOUT ELECTRONICS UNCERTAINTY

All uncertainties related to the probe readout electronics (DAE unit), including the gain and linearity of the instrumentation amplifier, its loading effect on the probe, and accuracy of the signal conversion algorithm, have been assessed accordingly to IEEE 1528 / EN 62209-1. The combination (root-sum-square RSS method) of these components results in an overall maximum error of $\pm 1.0\%$.

7.6. RESPONSE TIME UNCERTAINTY

The time response of the field probes is assessed by exposing the probe to a well-controlled electric field producing SAR larger than 2.0W/kg at the tissue medium surface. The signal response time is evaluated as the time required by the system to reach 90% of the expected final value after an on/of switch of the power source. Analytically, it can be expressed as:

$$SAR_{tolerance} [\%] = 100 \times \left(\frac{T_m}{T_m + \tau e^{-T_m/\tau}} - 1 \right)$$

where T_m is 500 ms, i.e., the time between measurement samples, and τ the time constant. The response time τ of SPEAG's probes is $< 5\text{ms}$. In the current implementation, DASY4 waits longer than 100 ms after having reached the grid point before starting a measurement, i.e., the response time uncertainty is negligible.

7.7. INTEGRATION TIME UNCERTAINTY

If the device under test does not emit a CW signal, the integration time applied to measure the electric field at a specific point may introduce additional uncertainties due to the discretization and can be assessed as follows

$$SAR_{tolerance} [\%] = 100 \times \sum_{all\ sub-frames} \frac{t_{frame}}{t_{integration}} \frac{slot_{idle}}{slot_{total}}$$

The tolerances for the different systems are given in Table 7.1, whereby the worst-case $SAR_{tolerance}$ is 2.6%.

System	$SAR_{tolerance}$ %
CW	0
CDMA*	0
WCDMA*	0
FDMA	0
IS-136	2.6
PDC	2.6
GSM/DCS/PCS	1.7
DECT	1.9
Worst-Case	2.6

TABLE 7.1

7.8. PROBE POSITIONER MECHANICAL TOLERANCE

The mechanical tolerance of the field probe positioner can introduce probe positioning uncertainties. The resulting SAR uncertainty is assessed by comparing the SAR obtained according to the specifications of the probe positioner with respect to the actual position defined by the geometric center of the probe sensors. The tolerance is determined as:

$$SAR_{tolerance} [\%] = 100 \times \frac{d_{ph}}{\delta/2}$$

The specified repeatability of the RX robot family used in DASY4 systems is $\pm 25\mu\text{m}$. The absolute accuracy for short distance movements is better than $\pm 0.1\text{mm}$, i.e., the $SAR_{tolerance}[\%]$ is better than 1.5% (rectangular).

7.9. PROBE POSITIONING

The probe positioning procedures affect the tolerance of the separation distance between the probe tip and the phantom surface as:

$$SAR_{tolerance} [\%] = 100 \times \frac{d_{ph}}{\delta/2}$$

where d_{ph} is the maximum deviation of the distance between the probe tip and the phantom surface. The optical surface detection has a precision of better than 0.2mm, resulting in an $SAR_{tolerance}[\%]$ of <2.9% (rectangular distribution). Since the mechanical detection provides better accuracy, 2.9% is a worst-case figure for DASY4 system.

7.10. PHANTOM UNCERTAINTY

The SAR measurement uncertainty due to SPEAG phantom shell production tolerances has been evaluated using

$$SAR_{tolerance} [\%] \cong 100 \times \frac{2d}{a}, \quad d \ll a$$

For a maximum deviation d of the inner and outer shell of the phantom from that specified in the CAD file of $\pm 0.2\text{mm}$, and a 10mm spacing a between source and tissue liquid, the calculated phantom uncertainty is $\pm 4.0\%$.

7.11. DASY4 UNCERTAINTY BUDGET

Error Description	Tolerance (±%)	Probability Distribution	Divisor	(C _i)		Standard Uncertainty (±%)		(v _i)
				(1g)	(10g)	(1g)	(10g)	
Measurement Equipment								
Probe Calibration	6.55	Normal	1	1	1	6.55	6.55	∞
Axial Isotropy	4.70	Rectangular	√3	0.7	0.7	1.90	1.90	∞
Hemispherical Isotropy	9.60	Rectangular	√3	0.7	0.7	3.88	3.88	∞
Boundary effects	2.00	Rectangular	√3	1	1	1.15	1.15	∞
Linearity	4.70	Rectangular	√3	1	1	2.71	2.71	∞
System Detection Limits	1.00	Rectangular	√3	1	1	0.58	0.58	∞
Readout Electronics	0.30	Normal	1	1	1	0.30	0.30	∞
Response Time	0.80	Rectangular	√3	1	1	0.46	0.46	∞
Integration Time	2.60	Rectangular	√3	1	1	1.50	1.50	∞
RF Ambient Noise	3.00	Rectangular	√3	1	1	1.73	1.73	∞
RF Ambient Reflections	3.00	Rectangular	√3	1	1	1.73	1.73	∞
Probe Positioner	0.80	Rectangular	√3	1	1	0.46	0.46	∞
Probe Positioning	9.90	Rectangular	√3	1	1	5.72	5.72	∞
Max. SAR Eval.	4.00	Rectangular	√3	1	1	2.31	2.31	∞
Test Sample Related								
Device Positioning	0.89	Normal	1	1	1	0.89	0.89	9
Device Holder	3.60	Normal	1	1	1	3.60	3.60	5
Power Drift	5.00	Rectangular	√3	1	1	2.89	2.89	∞
Phantom and Tissue parameters								
Phantom Uncertainty	4.00	Rectangular	√3	1	1	2.31	2.31	∞
Liquid Conductivity (target)	5.00	Rectangular	√3	0.64	0.43	1.85	1.24	∞
Liquid Conductivity (measurement)	4.91	Normal	1	0.64	0.43	3.14	2.11	∞
Liquid Permittivity (target)	5.00	Rectangular	√3	0.6	0.49	1.73	1.41	∞
Liquid Permittivity (measurement)	4.24	Normal	1	0.6	0.49	2.54	2.08	∞
Combined Standard Uncertainty						12.94	12.53	
Coverage Factor for 95%						Kp=2		
Expanded Uncertainty (K=2)						25.89	25.07	

TABLE 7.2

The table 7.2: Worst-Case uncertainty budget for DASY4 assessed according to IEEE 1528. The budget is valid for the frequency range 300MHz ~ 3GHz and represents a worst-case analysis. For specific tests and configurations, the uncertainty could be considerable smaller.

8. INFORMATION ON THE TESTING LABORATORIES

We, Bureau Veritas Consumer Products Services (H.K.) Ltd., Taoyuan Branch, were founded in 1988 to provide our best service in EMC, Radio, Telecom and Safety consultation. Our laboratories are accredited and approved by the following approval agencies according to ISO/IEC 17025.

USA	FCC, NVLAP
GERMANY	TUV Rheinland
JAPAN	VCCI
NORWAY	NEMKO
CANADA	INDUSTRY CANADA, CSA
R.O.C.	TAF, BSMI, NCC
NETHERLANDS	Telefication
SINGAPORE	GOST-ASIA (MOU)
RUSSIA	CERTIS (MOU)

Copies of accreditation certificates of our laboratories obtained from approval agencies can be downloaded from our web site: www.adt.com.tw/index.5/phtml. If you have any comments, please feel free to contact us at the following:

Linko EMC/RF Lab:
Tel: 886-2-26052180
Fax: 886-2-26051924

Hsin Chu EMC/RF Lab:
Tel: 886-3-5935343
Fax: 886-3-5935342

Hwa Ya EMC/RF/Safety/Telecom Lab:
Tel: 886-3-3183232
Fax: 886-3-3185050

Web Site: www.adt.com.tw

The address and road map of all our labs can be found in our web site also.

---END---

APPENDIX A: TEST DATA

Liquid Level Photo

Tissue MSL2450MHz D=150mm



Tissue MSL2450MHz D=152mm



Tissue MSL5800MHz D=154mm



Tissue MSL5800MHz D=152mm

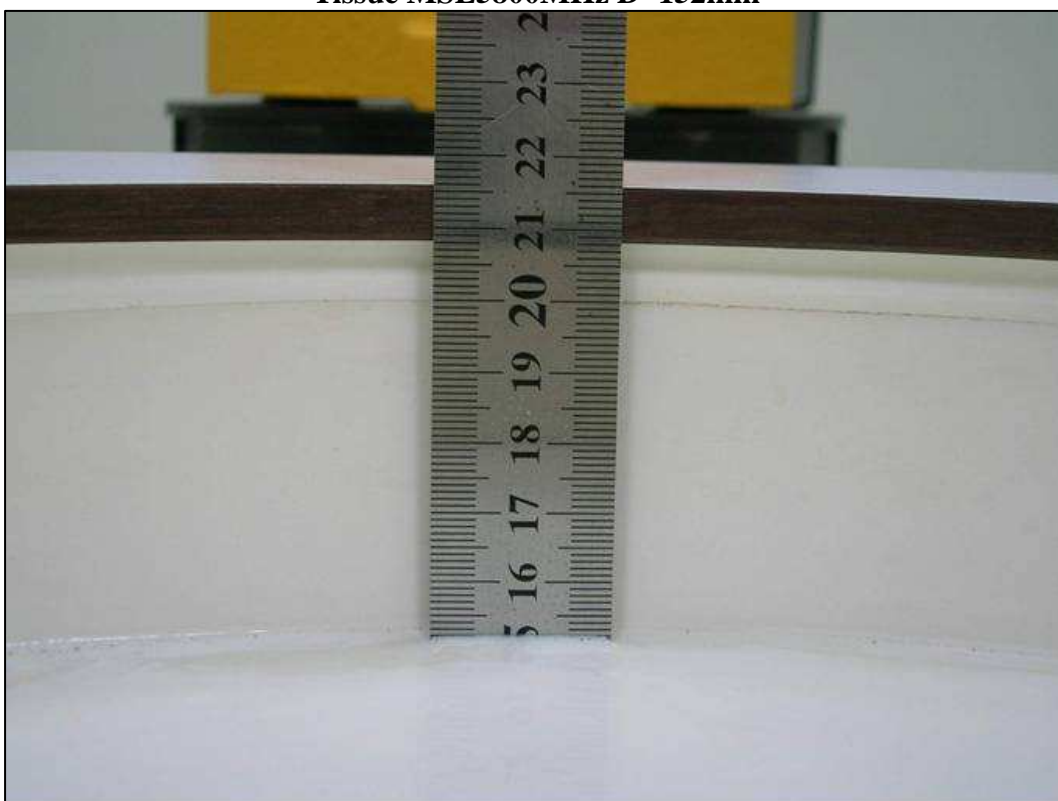

Test Laboratory: Bureau Veritas ADT

M01-11g-Ch6 / Main

DUT: MC3190 ; Type: Rotate

Communication System: 802.11g ; Frequency: 2437 MHz ; Duty Cycle: 1:1
 Medium: MSL2450 Medium parameters used: $f = 2437$ MHz; $\sigma = 1.92$ mho/m; $\epsilon_r = 53.7$; $\rho = 1000$ kg/m³
 Phantom section: Flat Section ; DUT test position : Body ; Modulation Type: BPSK
 Separation Distance : 0 mm (The back side of the EUT with leather to the Phantom)

DASY4 Configuration:

- Probe: EX3DV3 - SN3504 ; ConvF(7.53, 7.53, 7.53) ; Calibrated: 2009/1/21
- Sensor-Surface: 3mm (Mechanical Surface Detection)
- Electronics: DAE3 Sn510 ; Calibrated: 2009/1/21
- Phantom: SAM 12 ; Type: SAM V4.0; Serial: TP 1202
- Measurement SW: DASY4, V4.7 Build 80 ; Postprocessing SW: SEMCAD, V1.8 Build 186

Mid Channel 6/Area Scan (9x17x1): Measurement grid: dx=15mm, dy=15mm
 Maximum value of SAR (measured) = 0.066 mW/g

Mid Channel 6/Zoom Scan (7x7x7) (7x7x7)/Cube 0: Measurement grid: dx=5mm, dy=5mm, dz=5mm

Reference Value = 5.80 V/m; Power Drift = -0.086 dB

Peak SAR (extrapolated) = 0.094 W/kg

SAR(1 g) = 0.052 mW/g; SAR(10 g) = 0.025 mW/g

Maximum value of SAR (measured) = 0.067 mW/g

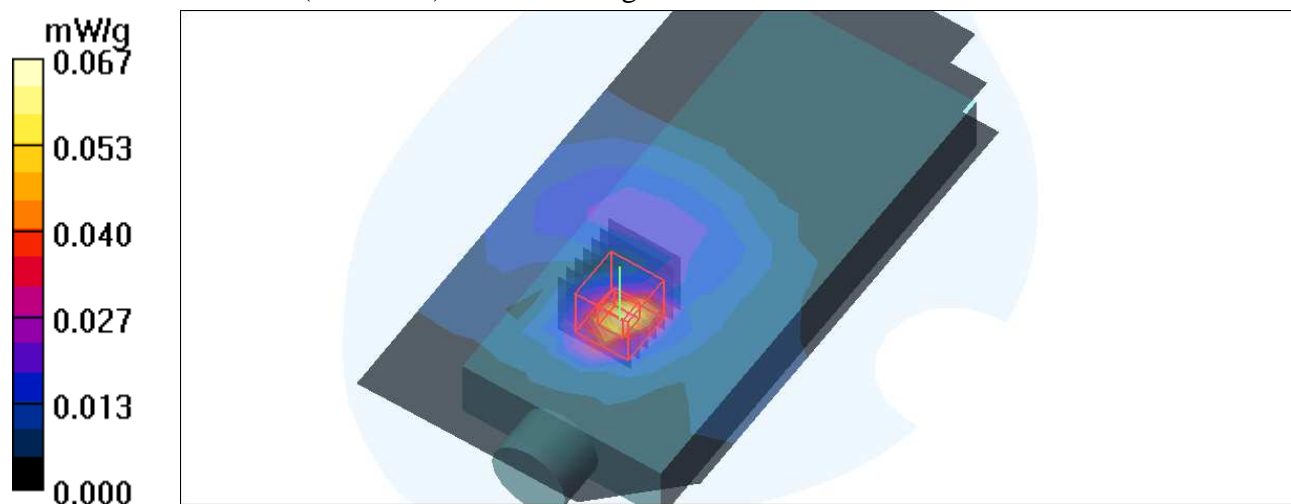

Test Laboratory: Bureau Veritas ADT

M02-11g-Ch6 / Aux

DUT: MC3190 ; Type: Rotate

Communication System: 802.11g ; Frequency: 2437 MHz ; Duty Cycle: 1:1
 Medium: MSL2450 Medium parameters used: $f = 2437$ MHz; $\sigma = 1.92$ mho/m; $\epsilon_r = 53.7$; $\rho = 1000$ kg/m³
 Phantom section: Flat Section ; DUT test position : Body ; Modulation Type: BPSK
 Separation Distance : 0 mm (The back side of the EUT with leather to the Phantom)

DASY4 Configuration:

- Probe: EX3DV3 - SN3504 ; ConvF(7.53, 7.53, 7.53) ; Calibrated: 2009/1/21
- Sensor-Surface: 3mm (Mechanical Surface Detection)
- Electronics: DAE3 Sn510 ; Calibrated: 2009/1/21
- Phantom: SAM 12 ; Type: SAM V4.0; Serial: TP 1202
- Measurement SW: DASY4, V4.7 Build 80 ; Postprocessing SW: SEMCAD, V1.8 Build 186

Mid Channel 6/Area Scan (9x17x1): Measurement grid: dx=15mm, dy=15mm

Maximum value of SAR (measured) = 0.019 mW/g

Mid Channel 6/Zoom Scan (7x7x7) (7x7x7)/Cube 0: Measurement grid: dx=5mm, dy=5mm, dz=5mm

Reference Value = 3.08 V/m; Power Drift = 0.094 dB

Peak SAR (extrapolated) = 0.045 W/kg

SAR(1 g) = 0.019 mW/g; SAR(10 g) = 0.00976 mW/g

Maximum value of SAR (measured) = 0.024 mW/g

Mid Channel 6/Zoom Scan (7x7x7) (7x7x7)/Cube 1: Measurement grid: dx=5mm, dy=5mm, dz=5mm

Reference Value = 3.08 V/m; Power Drift = 0.094 dB

Peak SAR (extrapolated) = 0.027 W/kg

SAR(1 g) = 0.014 mW/g; SAR(10 g) = 0.0084 mW/g

Maximum value of SAR (measured) = 0.018 mW/g

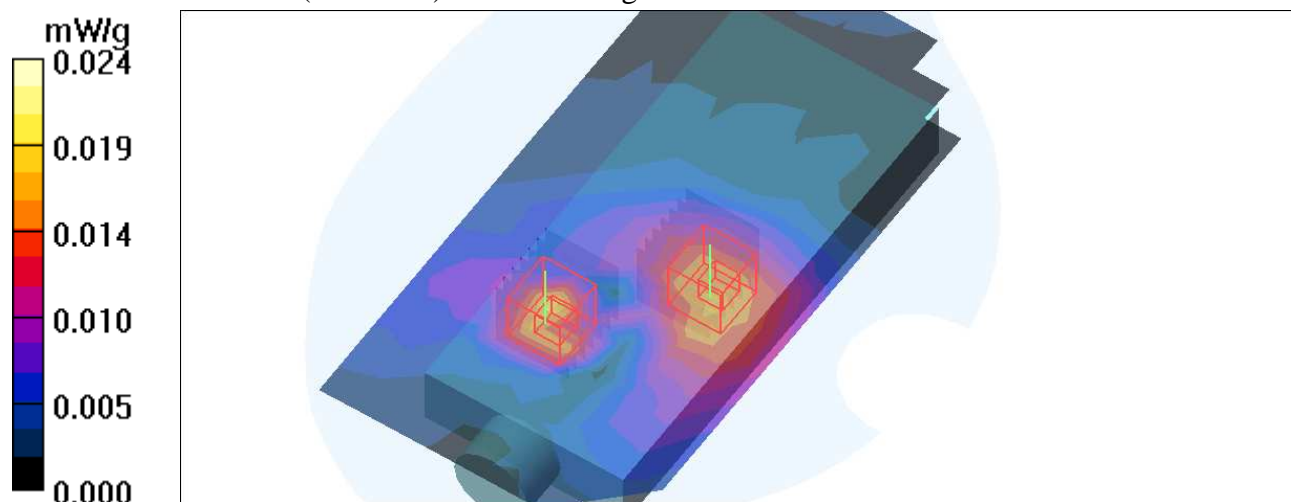

Test Laboratory: Bureau Veritas ADT

M03-Front-11g-Ch6 / Main

DUT: MC3190 ; Type: Rotate

Communication System: 802.11g ; Frequency: 2437 MHz ; Duty Cycle: 1:1

Medium: MSL2450 Medium parameters used: $f = 2437$ MHz; $\sigma = 1.92$ mho/m; $\epsilon_r = 53.7$; $\rho = 1000$ kg/m³

Phantom section: Flat Section ; DUT test position : Body ; Modulation Type: BPSK

Separation Distance : 0 mm (The front side of the EUT with leather to the Phantom)

DASY4 Configuration:

- Probe: EX3DV3 - SN3504 ; ConvF(7.53, 7.53, 7.53) ; Calibrated: 2009/1/21
- Sensor-Surface: 3mm (Mechanical Surface Detection)
- Electronics: DAE3 Sn510 ; Calibrated: 2009/1/21
- Phantom: SAM 12 ; Type: SAM V4.0; Serial: TP 1202
- Measurement SW: DASY4, V4.7 Build 80 ; Postprocessing SW: SEMCAD, V1.8 Build 186

Mid Channel 6/Area Scan (11x17x1): Measurement grid: dx=15mm, dy=15mm

Maximum value of SAR (measured) = 0.010 mW/g

Mid Channel 6/Zoom Scan (7x7x7) (7x7x7)/Cube 0: Measurement grid: dx=5mm, dy=5mm, dz=5mm

Reference Value = 2.38 V/m; Power Drift = 0.147 dB

Peak SAR (extrapolated) = 0.017 W/kg

SAR(1 g) = 0.00982 mW/g; SAR(10 g) = 0.00475 mW/g

Maximum value of SAR (measured) = 0.013 mW/g

Mid Channel 6/Zoom Scan (7x7x7) (7x7x7)/Cube 1: Measurement grid: dx=5mm, dy=5mm, dz=5mm

Reference Value = 2.38 V/m; Power Drift = 0.147 dB

Peak SAR (extrapolated) = 0.015 W/kg

SAR(1 g) = 0.00773 mW/g; SAR(10 g) = 0.0045 mW/g

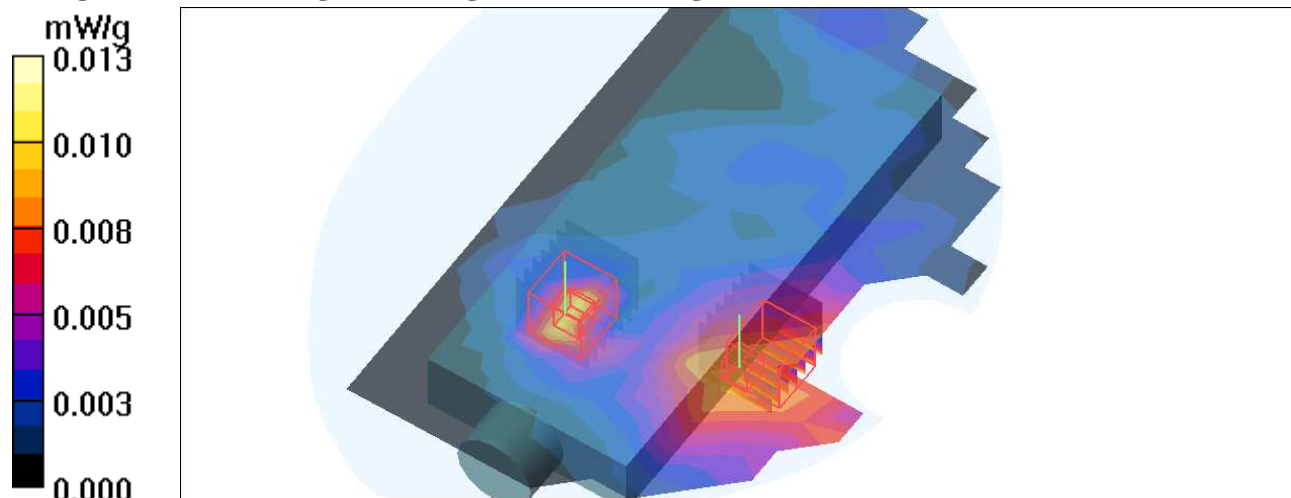

Test Laboratory: Bureau Veritas ADT

M04-Front-11g-Ch6 / Aux

DUT: MC3190 ; Type: Rotate

Communication System: 802.11g ; Frequency: 2437 MHz ; Duty Cycle: 1:1

Medium: MSL2450 Medium parameters used: $f = 2437 \text{ MHz}$; $\sigma = 1.92 \text{ mho/m}$; $\epsilon_r = 53.7$; $\rho = 1000 \text{ kg/m}^3$

Phantom section: Flat Section ; DUT test position : Body ; Modulation Type: BPSK

Separation Distance : 0 mm (The front side of the EUT with leather to the Phantom)

DASY4 Configuration:

- Probe: EX3DV3 - SN3504 ; ConvF(7.53, 7.53, 7.53) ; Calibrated: 2009/1/21
- Sensor-Surface: 3mm (Mechanical Surface Detection)
- Electronics: DAE3 Sn510 ; Calibrated: 2009/1/21
- Phantom: SAM 12 ; Type: SAM V4.0; Serial: TP 1202
- Measurement SW: DASY4, V4.7 Build 80 ; Postprocessing SW: SEMCAD, V1.8 Build 186

Mid Channel 6/Area Scan (11x17x1): Measurement grid: $dx=15\text{mm}$, $dy=15\text{mm}$

Maximum value of SAR (measured) = 0.015 mW/g

Mid Channel 6/Zoom Scan (7x7x7) (7x7x7)/Cube 0: Measurement grid: $dx=5\text{mm}$, $dy=5\text{mm}$, $dz=5\text{mm}$

Reference Value = 2.81 V/m; Power Drift = -0.001 dB

Peak SAR (extrapolated) = 0.023 W/kg

SAR(1 g) = **0.013 mW/g**; SAR(10 g) = 0.00753 mW/g

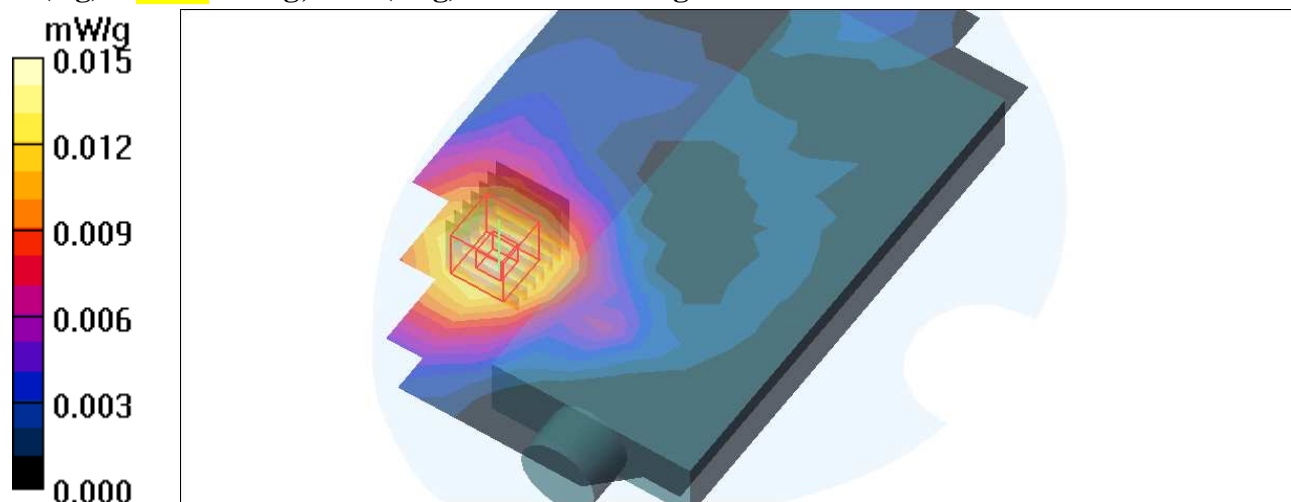

Test Laboratory: Bureau Veritas ADT

M05-11b-Ch1 / Main**DUT: MC3190 ; Type: Rotate**

Communication System: 802.11b ; Frequency: 2412 MHz ; Duty Cycle: 1:1

Medium: MSL2450 Medium parameters used: $f = 2412$ MHz; $\sigma = 1.88$ mho/m; $\epsilon_r = 53.8$; $\rho = 1000$ kg/m³

Phantom section: Flat Section ; DUT test position : Body ; Modulation Type: DBPSK

Separation Distance : 0 mm (The back side of the EUT with leather to the Phantom)

DASY4 Configuration:

- Probe: EX3DV3 - SN3504 ; ConvF(7.53, 7.53, 7.53) ; Calibrated: 2009/1/21

- Sensor-Surface: 3mm (Mechanical Surface Detection)

- Electronics: DAE3 Sn510 ; Calibrated: 2009/1/21

- Phantom: SAM 12 ; Type: SAM V4.0; Serial: TP 1202

- Measurement SW: DASY4, V4.7 Build 80 ; Postprocessing SW: SEMCAD, V1.8 Build 186

Low Channel 1/Area Scan (9x17x1): Measurement grid: dx=15mm, dy=15mm

Maximum value of SAR (measured) = 0.041 mW/g

Low Channel 1/Zoom Scan (7x7x7) (7x7x7)/Cube 0: Measurement grid: dx=5mm, dy=5mm, dz=5mm

Reference Value = 4.56 V/m; Power Drift = -0.131 dB

Peak SAR (extrapolated) = 0.066 W/kg

SAR(1 g) = **0.036** mW/g; SAR(10 g) = **0.017** mW/g

Maximum value of SAR (measured) = 0.046 mW/g

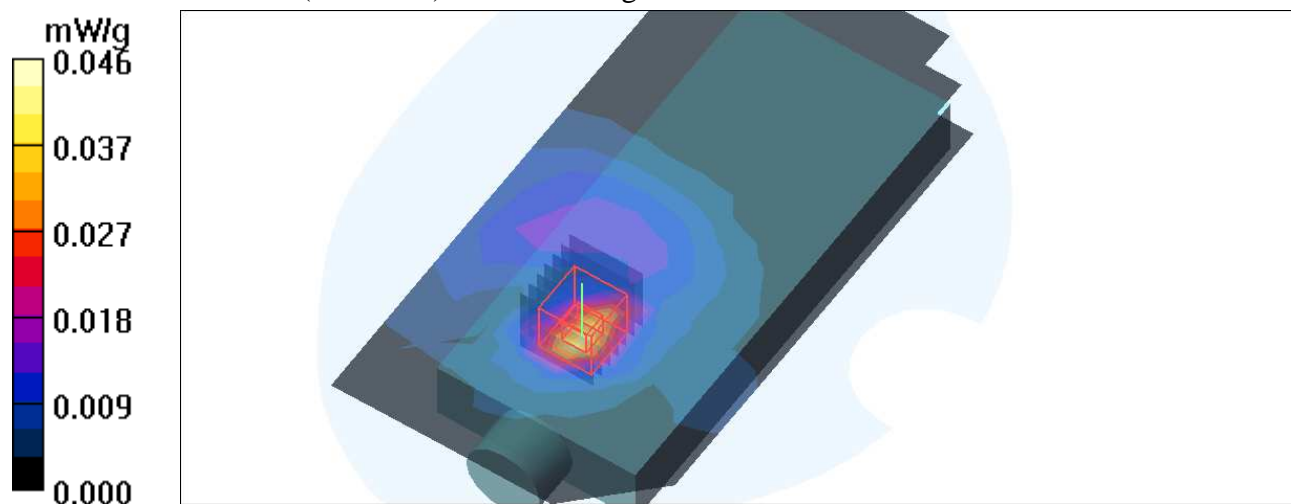

Test Laboratory: Bureau Veritas ADT

M06-11a-Ch149 / Main

DUT: MC3190 ; Type: Rotate

Communication System: 802.11a ; Frequency: 5745 MHz ; Duty Cycle: 1:1

Medium: MSL5800 Medium parameters used: $f = 5745$ MHz; $\sigma = 6.03$ mho/m; $\epsilon_r = 48.8$; $\rho = 1000$ kg/m³

Phantom section: Flat Section ; DUT test position : Body ; Modulation Type: BPSK

Separation Distance : 0 mm (The back side of the EUT with leather to the Phantom)

DASY4 Configuration:

- Probe: EX3DV3 - SN3504 ; ConvF(3.98, 3.98, 3.98) ; Calibrated: 2009/1/21

- Sensor-Surface: 3mm (Mechanical Surface Detection)

- Electronics: DAE3 Sn510 ; Calibrated: 2009/1/21

- Phantom: SAM 12 ; Type: SAM V4.0; Serial: TP 1202

- Measurement SW: DASY4, V4.7 Build 80 ; Postprocessing SW: SEMCAD, V1.8 Build 186

Low Channel 149/Area Scan (13x23x1): Measurement grid: dx=10mm, dy=10mm

Maximum value of SAR (measured) = 0.174 mW/g

Low Channel 149/Zoom Scan (8x8x8)/Cube 0: Measurement grid: dx=4.3mm, dy=4.3mm, dz=3mm

Reference Value = 5.67 V/m; Power Drift = 0.046 dB

Peak SAR (extrapolated) = 0.381 W/kg

SAR(1 g) = 0.102 mW/g; SAR(10 g) = 0.027 mW/g

Maximum value of SAR (measured) = 0.177 mW/g

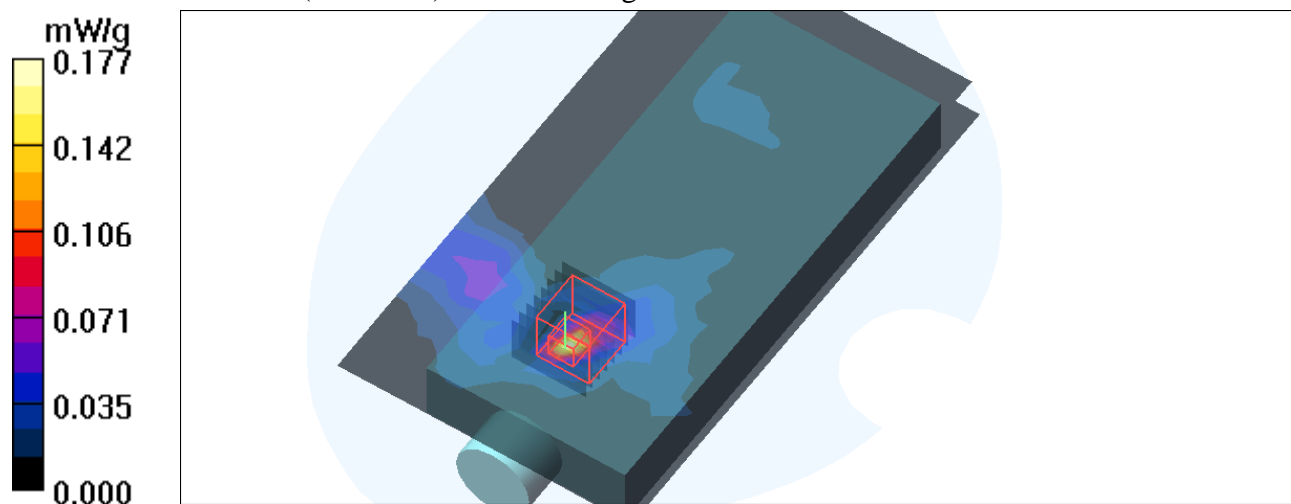

Test Laboratory: Bureau Veritas ADT

M07-11g-Ch6 / Main

DUT: MC3190 ; Type: Straight

Communication System: 802.11g ; Frequency: 2437 MHz ; Duty Cycle: 1:1

Medium: MSL2450 Medium parameters used: $f = 2437$ MHz; $\sigma = 1.94$ mho/m; $\epsilon_r = 54$; $\rho = 1000$ kg/m³

Phantom section: Flat Section ; DUT test position : Body ; Modulation Type: BPSK

Separation Distance : 0 mm (The back side of the EUT with leather to the Phantom)

DASY4 Configuration:

- Probe: EX3DV3 - SN3504 ; ConvF(7.53, 7.53, 7.53) ; Calibrated: 2009/1/21

- Sensor-Surface: 3mm (Mechanical Surface Detection)

- Electronics: DAE3 Sn510 ; Calibrated: 2009/1/21

- Phantom: SAM 12 ; Type: SAM V4.0; Serial: TP 1202

- Measurement SW: DASY4, V4.7 Build 80 ; Postprocessing SW: SEMCAD, V1.8 Build 186

Mid Channel 6/Area Scan (9x17x1): Measurement grid: dx=15mm, dy=15mm

Maximum value of SAR (measured) = 0.125 mW/g

Mid Channel 6/Zoom Scan (7x7x7) (7x7x7)/Cube 0: Measurement grid: dx=5mm, dy=5mm, dz=5mm

Reference Value = 7.50 V/m; Power Drift = -0.061 dB

Peak SAR (extrapolated) = 0.167 W/kg

SAR(1 g) = 0.090 mW/g; SAR(10 g) = 0.045 mW/g

Maximum value of SAR (measured) = 0.112 mW/g

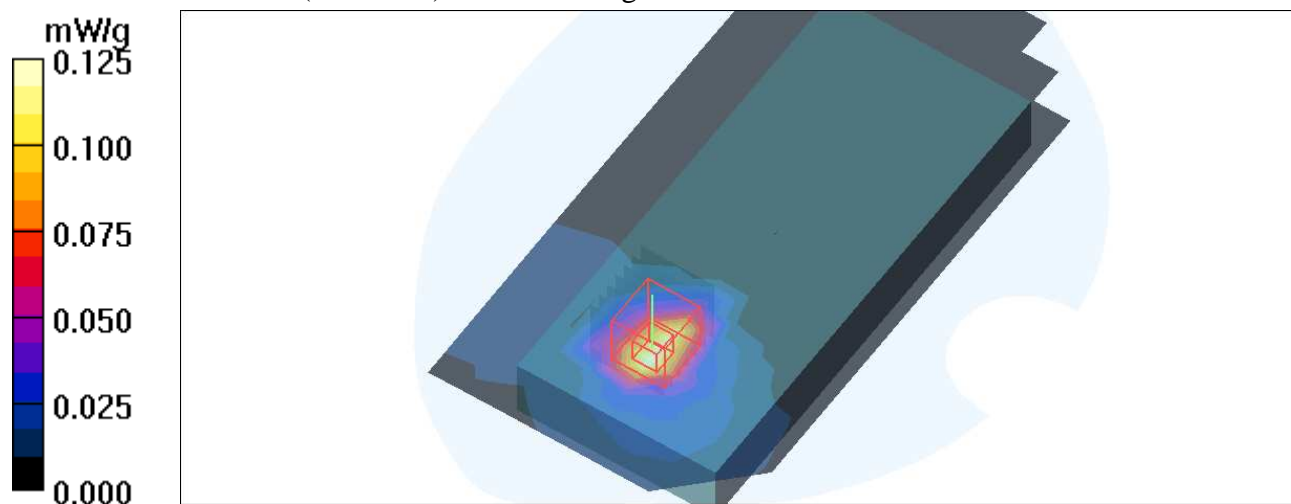

Test Laboratory: Bureau Veritas ADT

M08-11g-Ch6 / Aux**DUT: MC3190 ; Type: Straight**

Communication System: 802.11g ; Frequency: 2437 MHz ; Duty Cycle: 1:1

Medium: MSL2450 Medium parameters used: $f = 2437$ MHz; $\sigma = 1.94$ mho/m; $\epsilon_r = 54$; $\rho = 1000$ kg/m³

Phantom section: Flat Section ; DUT test position : Body ; Modulation Type: BPSK

Separation Distance : 0 mm (The back side of the EUT with leather to the Phantom)

DASY4 Configuration:

- Probe: EX3DV3 - SN3504 ; ConvF(7.53, 7.53, 7.53) ; Calibrated: 2009/1/21

- Sensor-Surface: 3mm (Mechanical Surface Detection)

- Electronics: DAE3 Sn510 ; Calibrated: 2009/1/21

- Phantom: SAM 12 ; Type: SAM V4.0; Serial: TP 1202

- Measurement SW: DASY4, V4.7 Build 80 ; Postprocessing SW: SEMCAD, V1.8 Build 186

Mid Channel 6/Area Scan (9x17x1): Measurement grid: dx=15mm, dy=15mm

Maximum value of SAR (measured) = 0.040 mW/g

Mid Channel 6/Zoom Scan (7x7x7) (7x7x7)/Cube 0: Measurement grid: dx=5mm, dy=5mm, dz=5mm

Reference Value = 4.48 V/m; Power Drift = -0.037 dB

Peak SAR (extrapolated) = 0.057 W/kg

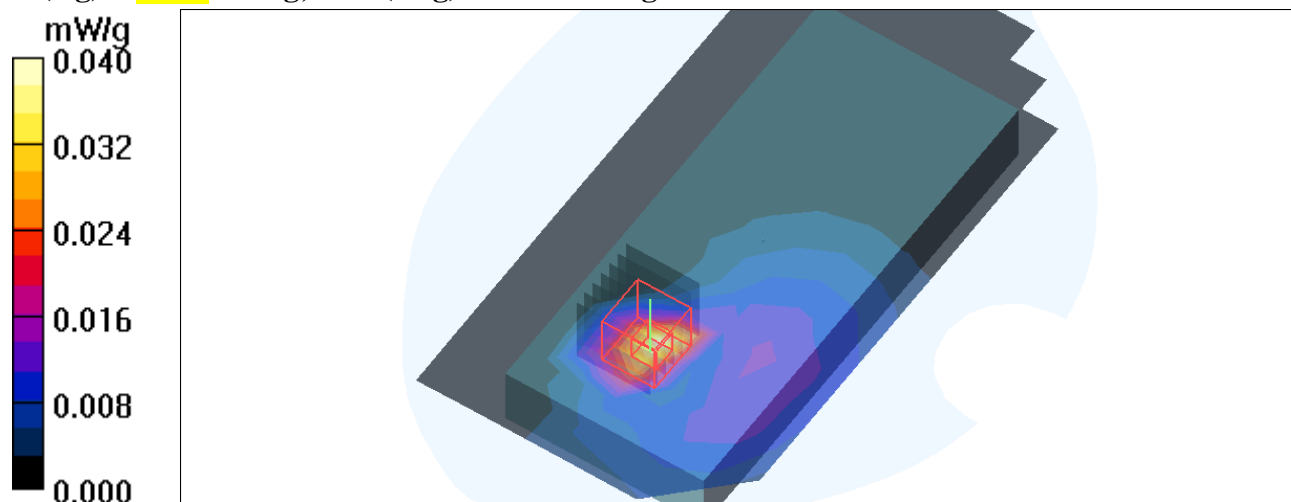
SAR(1 g) = **0.032** mW/g; SAR(10 g) = 0.015 mW/g

Test Laboratory: Bureau Veritas ADT

M09-11g-Ch6 / Main / 2D**DUT: MC3190 ; Type: Straight**

Communication System: 802.11g ; Frequency: 2437 MHz ; Duty Cycle: 1:1

Medium: MSL2450 Medium parameters used: $f = 2437$ MHz; $\sigma = 1.94$ mho/m; $\epsilon_r = 54$; $\rho = 1000$ kg/m³

Phantom section: Flat Section ; DUT test position : Body ; Modulation Type: BPSK

Separation Distance : 0 mm (The back side of the EUT with leather to the Phantom)

DASY4 Configuration:

- Probe: EX3DV3 - SN3504 ; ConvF(7.53, 7.53, 7.53) ; Calibrated: 2009/1/21

- Sensor-Surface: 3mm (Mechanical Surface Detection)

- Electronics: DAE3 Sn510 ; Calibrated: 2009/1/21

- Phantom: SAM 12 ; Type: SAM V4.0; Serial: TP 1202

- Measurement SW: DASY4, V4.7 Build 80 ; Postprocessing SW: SEMCAD, V1.8 Build 186

Mid Channel 6/Area Scan (9x17x1): Measurement grid: dx=15mm, dy=15mm

Maximum value of SAR (measured) = 0.088 mW/g

Mid Channel 6/Zoom Scan (7x7x7) (7x7x7)/Cube 0: Measurement grid: dx=5mm, dy=5mm, dz=5mm

Reference Value = 6.58 V/m; Power Drift = -0.023 dB

Peak SAR (extrapolated) = 0.149 W/kg

SAR(1 g) = 0.082 mW/g; SAR(10 g) = 0.042 mW/g

Maximum value of SAR (measured) = 0.105 mW/g

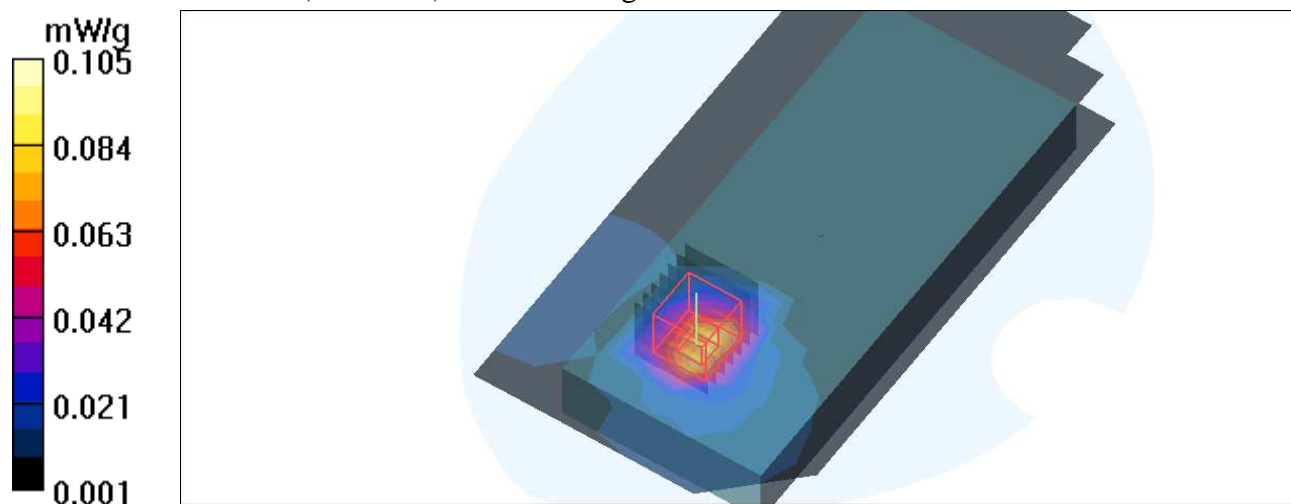

Test Laboratory: Bureau Veritas ADT

M10-11b-Ch1 / Main

DUT: MC3190 ; Type: Straight

Communication System: 802.11b ; Frequency: 2412 MHz ; Duty Cycle: 1:1

Medium: MSL2450 Medium parameters used: $f = 2412$ MHz; $\sigma = 1.9$ mho/m; $\epsilon_r = 54.1$; $\rho = 1000$ kg/m³

Phantom section: Flat Section ; DUT test position : Body ; Modulation Type: DBPSK

Separation Distance : 0 mm (The back side of the EUT with leather to the Phantom)

DASY4 Configuration:

- Probe: EX3DV3 - SN3504 ; ConvF(7.53, 7.53, 7.53) ; Calibrated: 2009/1/21

- Sensor-Surface: 3mm (Mechanical Surface Detection)

- Electronics: DAE3 Sn510 ; Calibrated: 2009/1/21

- Phantom: SAM 12 ; Type: SAM V4.0; Serial: TP 1202

- Measurement SW: DASY4, V4.7 Build 80 ; Postprocessing SW: SEMCAD, V1.8 Build 186

Low Channel 1/Area Scan (9x17x1): Measurement grid: dx=15mm, dy=15mm

Maximum value of SAR (measured) = 0.083 mW/g

Low Channel 1/Zoom Scan (7x7x7) (7x7x7)/Cube 0: Measurement grid: dx=5mm, dy=5mm, dz=5mm

Reference Value = 6.51 V/m; Power Drift = -0.006 dB

Peak SAR (extrapolated) = 0.136 W/kg

SAR(1 g) = 0.075 mW/g; SAR(10 g) = 0.037 mW/g

Maximum value of SAR (measured) = 0.094 mW/g

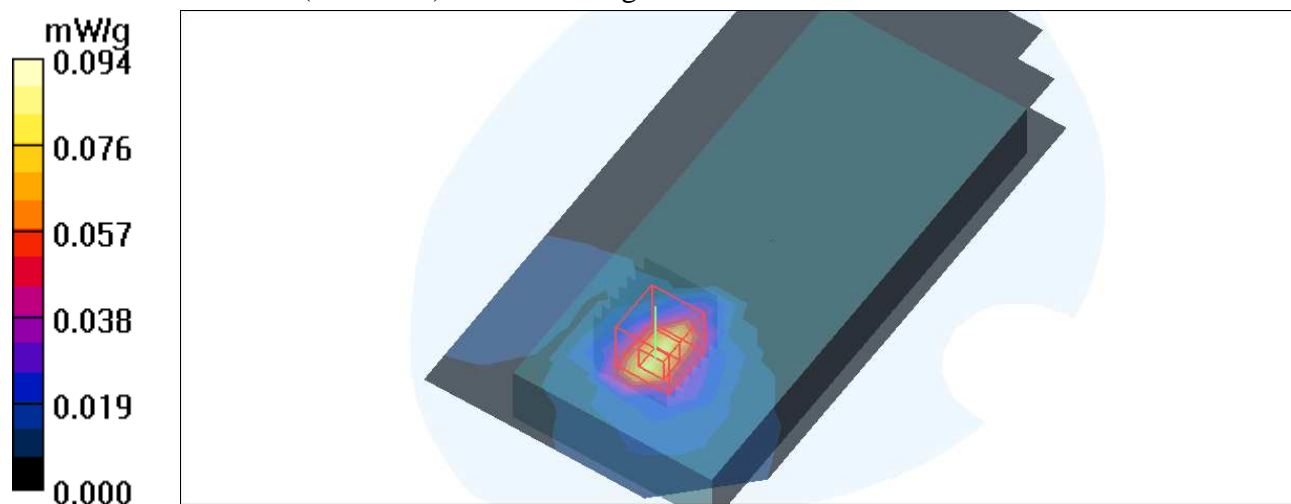

Test Laboratory: Bureau Veritas ADT

M11-11a-Ch149 / Main

DUT: MC3190 ; Type: Straight

Communication System: 802.11a ; Frequency: 5745 MHz ; Duty Cycle: 1:1
 Medium: MSL5800 Medium parameters used: $f = 5745 \text{ MHz}$; $\sigma = 5.99 \text{ mho/m}$; $\epsilon_r = 49.4$; $\rho = 1000 \text{ kg/m}^3$
 Phantom section: Flat Section ; DUT test position : Body ; Modulation Type: BPSK
 Separation Distance : 0 mm (The back side of the EUT with leather to the Phantom)

DASY4 Configuration:

- Probe: EX3DV3 - SN3504 ; ConvF(3.98, 3.98, 3.98) ; Calibrated: 2009/1/21
- Sensor-Surface: 3mm (Mechanical Surface Detection)
- Electronics: DAE3 Sn510 ; Calibrated: 2009/1/21
- Phantom: SAM 12 ; Type: SAM V4.0; Serial: TP 1202
- Measurement SW: DASY4, V4.7 Build 80 ; Postprocessing SW: SEMCAD, V1.8 Build 186

Low Channel 149/Area Scan (13x23x1): Measurement grid: $dx=10\text{mm}$, $dy=10\text{mm}$

Maximum value of SAR (measured) = 0.093 mW/g

Low Channel 149/Zoom Scan (8x8x8)/Cube 0: Measurement grid: $dx=4.3\text{mm}$, $dy=4.3\text{mm}$, $dz=3\text{mm}$

Reference Value = 3.96 V/m; Power Drift = 0.074 dB

Peak SAR (extrapolated) = 0.229 W/kg

SAR(1 g) = 0.061 mW/g; SAR(10 g) = 0.022 mW/g

Maximum value of SAR (measured) = 0.103 mW/g

Low Channel 149/Zoom Scan (8x8x8)/Cube 1: Measurement grid: $dx=4.3\text{mm}$, $dy=4.3\text{mm}$, $dz=3\text{mm}$

Reference Value = 3.96 V/m; Power Drift = 0.074 dB

Peak SAR (extrapolated) = 0.181 W/kg

SAR(1 g) = 0.050 mW/g; SAR(10 g) = 0.018 mW/g

Maximum value of SAR (measured) = 0.073 mW/g

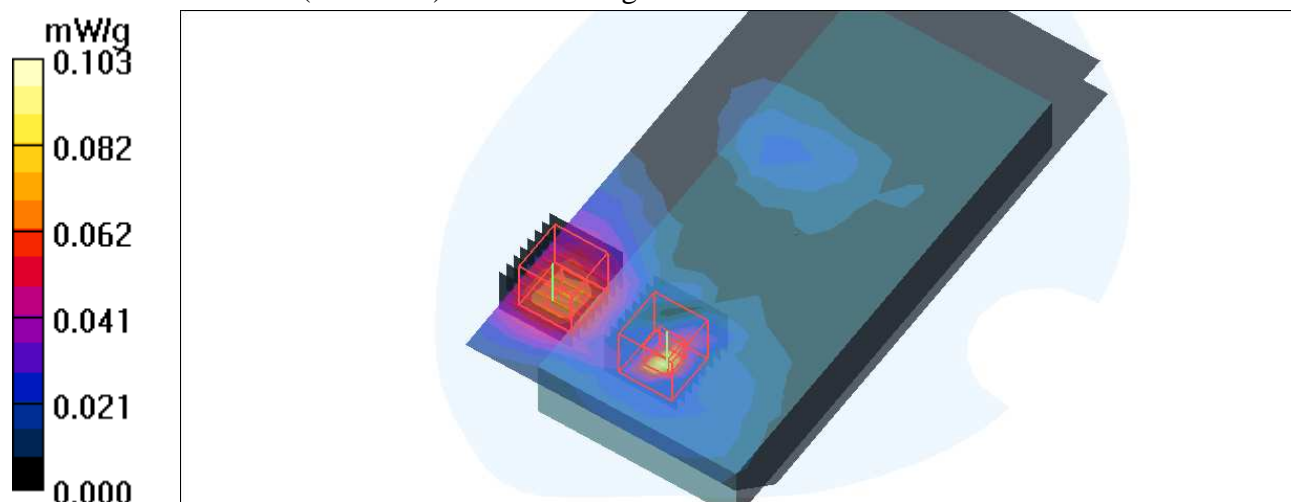

Test Laboratory: Bureau Veritas ADT

System Validation Check-MSL 2450MHz

DUT: Dipole 2450 MHz ; Type: D2450V2 ; Serial: 716 ; Test Frequency: 2450 MHz

Communication System: CW ; Frequency: 2450 MHz; Duty Cycle: 1:1; Modulation type: CW
 Medium: MSL2450; Medium parameters used: $f = 2450$ MHz; $\sigma = 1.94$ mho/m; $\epsilon_r = 53.7$; $\rho = 1000$ kg/m³ ; Liquid level : 150 mm
 Phantom section: Flat Section ; Separation distance : 10 mm (The feetpoint of the dipole to the Phantom) Air temp. : 22.8 degrees ; Liquid temp. : 21.9 degrees

DASY4 Configuration:

- Probe: EX3DV3 - SN3504 ; ConvF(7.53, 7.53, 7.53) ; Calibrated: 2009/1/21
- Sensor-Surface: 3mm (Mechanical Surface Detection)
- Electronics: DAE3 Sn510; Calibrated: 2009/1/21
- Phantom: SAM 12; Type: SAM V4.0; Serial: TP 1202
- Measurement SW: DASY4, V4.7 Build 80; Postprocessing SW: SEMCAD, V1.8 Build 186

d=10mm, Pin=250mW/Area Scan (5x7x1): Measurement grid: dx=15mm, dy=15mm
 Maximum value of SAR (measured) = 16.8 mW/g

d=10mm, Pin=250mW/Zoom Scan (7x7x7)/Cube 0: Measurement grid: dx=5mm, dy=5mm, dz=5mm

Reference Value = 92.3 V/m; Power Drift = -0.105 dB

Peak SAR (extrapolated) = 25.6 W/kg

SAR(1 g) = 12.6 mW/g; SAR(10 g) = 5.89 mW/g

Maximum value of SAR (measured) = 16.5 mW/g

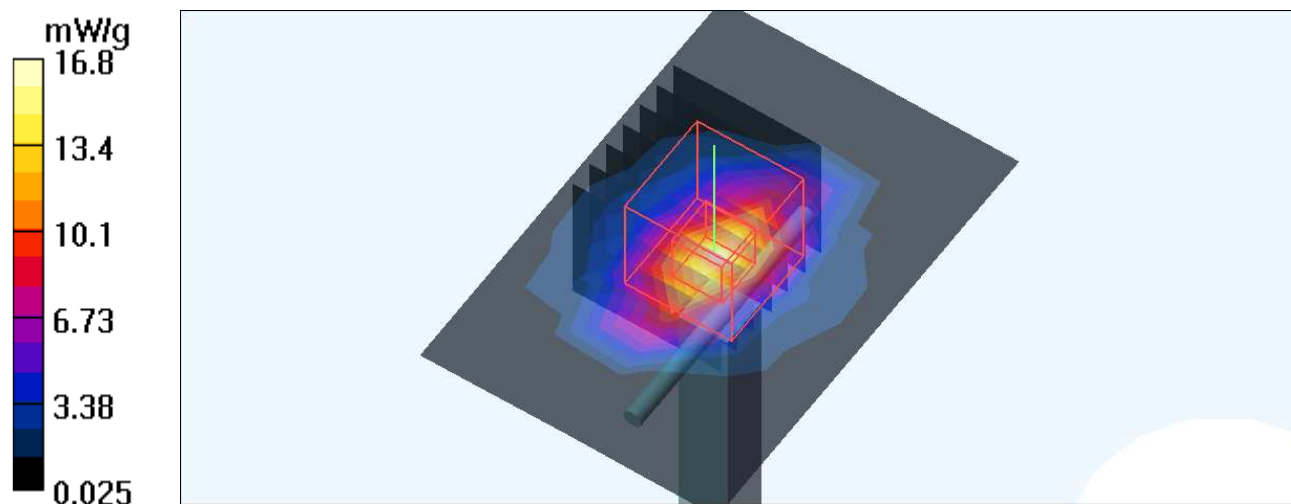

Test Laboratory: Bureau Veritas ADT

System Validation Check-MSL 2450MHz

DUT: Dipole 2450 MHz ; Type: D2450V2 ; Serial: 716 ; Test Frequency: 2450 MHz

Communication System: CW ; Frequency: 2450 MHz; Duty Cycle: 1:1; Modulation type: CW
 Medium: MSL2450; Medium parameters used: $f = 2450$ MHz; $\sigma = 1.96$ mho/m; $\epsilon_r = 54$; $\rho = 1000$ kg/m³ ;
 Liquid level : 152 mm
 Phantom section: Flat Section ; Separation distance : 10 mm (The feetpoint of the dipole to the Phantom)
 Air temp. : 23.0 degrees ; Liquid temp. : 21.8 degrees

DASY4 Configuration:

- Probe: EX3DV3 - SN3504 ; ConvF(7.53, 7.53, 7.53) ; Calibrated: 2009/1/21
- Sensor-Surface: 3mm (Mechanical Surface Detection)
- Electronics: DAE3 Sn510; Calibrated: 2009/1/21
- Phantom: SAM 12; Type: SAM V4.0; Serial: TP 1202
- Measurement SW: DASY4, V4.7 Build 80; Postprocessing SW: SEMCAD, V1.8 Build 186

d=10mm, Pin=250mW/Area Scan (5x7x1): Measurement grid: dx=15mm, dy=15mm
 Maximum value of SAR (measured) = 16.6 mW/g

d=10mm, Pin=250mW/Zoom Scan (7x7x7)/Cube 0: Measurement grid: dx=5mm, dy=5mm, dz=5mm

Reference Value = 92.9 V/m; Power Drift = -0.017 dB

Peak SAR (extrapolated) = 25.3 W/kg

SAR(1 g) = 12.4 mW/g; SAR(10 g) = 5.78 mW/g

Maximum value of SAR (measured) = 16.4 mW/g

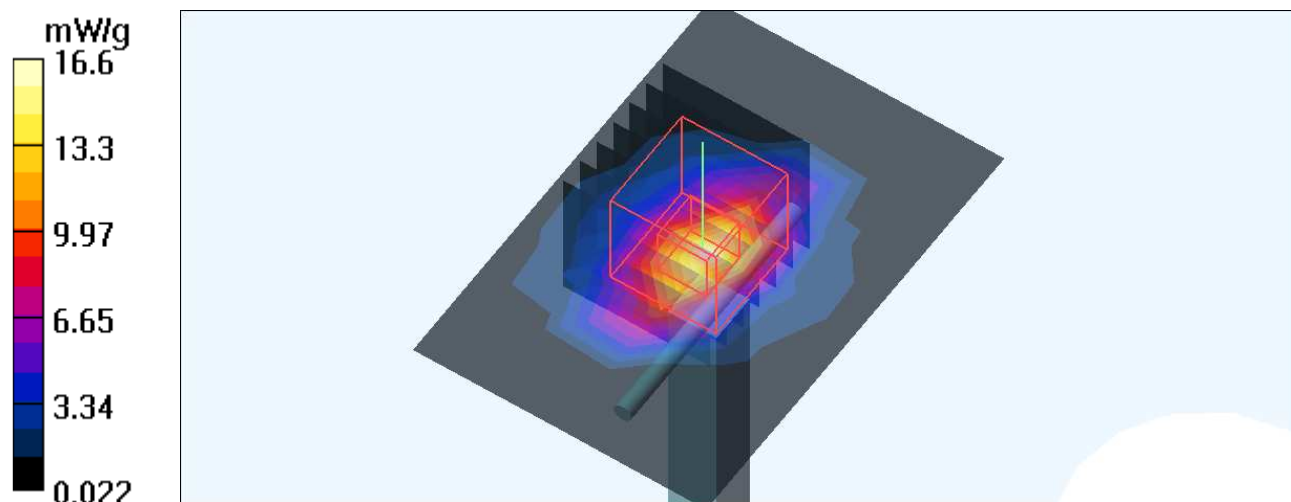

Test Laboratory: Bureau Veritas ADT

System Validation Check-MSL 5GHz

DUT: Dipole 5 GHz ; Type: D5GHzV2 ; Serial: 1019 ; Test Frequency: 5800 MHz

Communication System: CW ; Frequency: 5800 MHz; Duty Cycle: 1:1; Modulation type: CW
Medium: MSL5800; Medium parameters used: $f = 5800$ MHz; $\sigma = 6.1$ mho/m; $\epsilon_r = 48.8$; $\rho = 1000$ kg/m³ ;
Liquid level : 154 mm
Phantom section: Flat Section ; Separation distance : 10 mm (The feetpoint of the dipole to the Phantom)
Air temp. : 22.7 degrees ; Liquid temp. : 22.0 degrees

DASY4 Configuration:

- Probe: EX3DV3 - SN3504 ; ConvF(3.98, 3.98, 3.98) ; Calibrated: 2009/1/21
- Sensor-Surface: 3mm (Mechanical Surface Detection)
- Electronics: DAE3 Sn510; Calibrated: 2009/1/21
- Phantom: SAM 12; Type: SAM V4.0; Serial: TP 1202
- Measurement SW: DASY4, V4.7 Build 80; Postprocessing SW: SEMCAD, V1.8 Build 186

f=5800, d=10mm, Pin=100mW/Area Scan (6x6x1): Measurement grid: dx=10mm, dy=10mm
Maximum value of SAR (measured) = 7.20 mW/g

f=5800, d=10mm, Pin=100mW/Zoom Scan (8x8x8)/Cube 0: Measurement grid: dx=4.3mm, dy=4.3mm, dz=3mm

Reference Value = 44.2 V/m; Power Drift = -0.058 dB

Peak SAR (extrapolated) = 29.7 W/kg

SAR(1 g) = 7.19 mW/g; SAR(10 g) = 2.02 mW/g

Maximum value of SAR (measured) = 10.0 mW/g

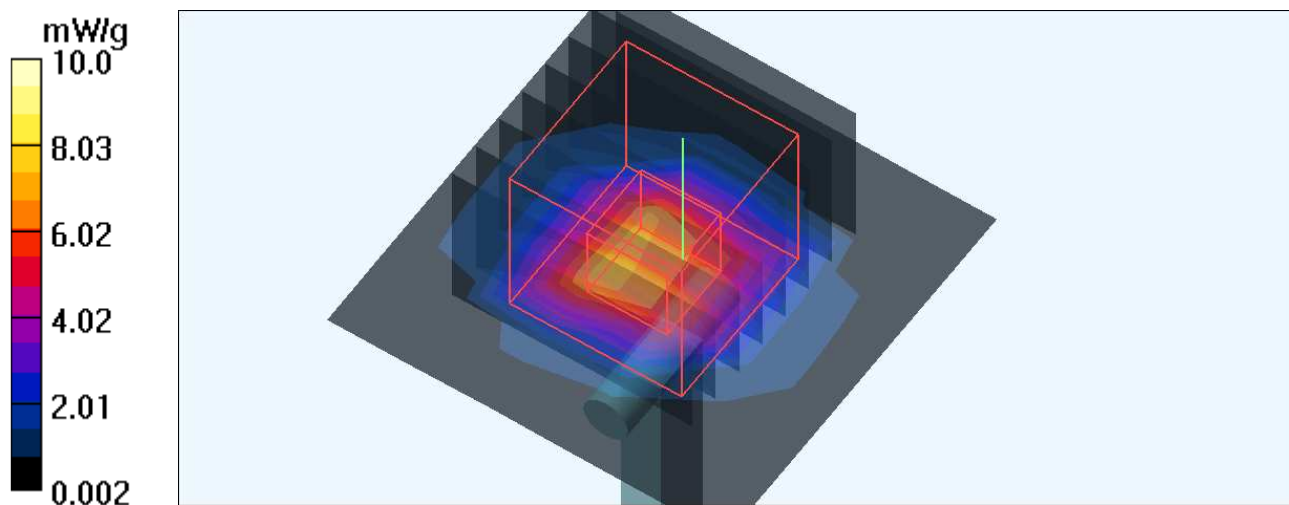

Test Laboratory: Bureau Veritas ADT

System Validation Check-MSL 5GHz

DUT: Dipole 5 GHz ; Type: D5GHzV2 ; Serial: 1019 ; Test Frequency: 5800 MHz

Communication System: CW ; Frequency: 5800 MHz; Duty Cycle: 1:1; Modulation type: CW
Medium: MSL5800; Medium parameters used: $f = 5800$ MHz; $\sigma = 6.08$ mho/m; $\epsilon_r = 49.3$; $\rho = 1000$ kg/m³ ; Liquid level : 152 mm

Phantom section: Flat Section ; Separation distance : 10 mm (The feetpoint of the dipole to the Phantom) Air temp. : 23.1 degrees ; Liquid temp. : 22.0 degrees

DASY4 Configuration:

- Probe: EX3DV3 - SN3504 ; ConvF(3.98, 3.98, 3.98) ; Calibrated: 2009/1/21
- Sensor-Surface: 3mm (Mechanical Surface Detection)
- Electronics: DAE3 Sn510; Calibrated: 2009/1/21
- Phantom: SAM 12; Type: SAM V4.0; Serial: TP 1202
- Measurement SW: DASY4, V4.7 Build 80; Postprocessing SW: SEMCAD, V1.8 Build 186

f=5800, d=10mm, Pin=100mW/Area Scan (6x6x1): Measurement grid: dx=10mm, dy=10mm
Maximum value of SAR (measured) = 7.64 mW/g

f=5800, d=10mm, Pin=100mW/Zoom Scan (8x8x8)/Cube 0: Measurement grid: dx=4.3mm, dy=4.3mm, dz=3mm

Reference Value = 43.7 V/m; Power Drift = -0.040 dB

Peak SAR (extrapolated) = 30.2 W/kg

SAR(1 g) = 7.22 mW/g; SAR(10 g) = 2.02 mW/g

Maximum value of SAR (measured) = 10.7 mW/g

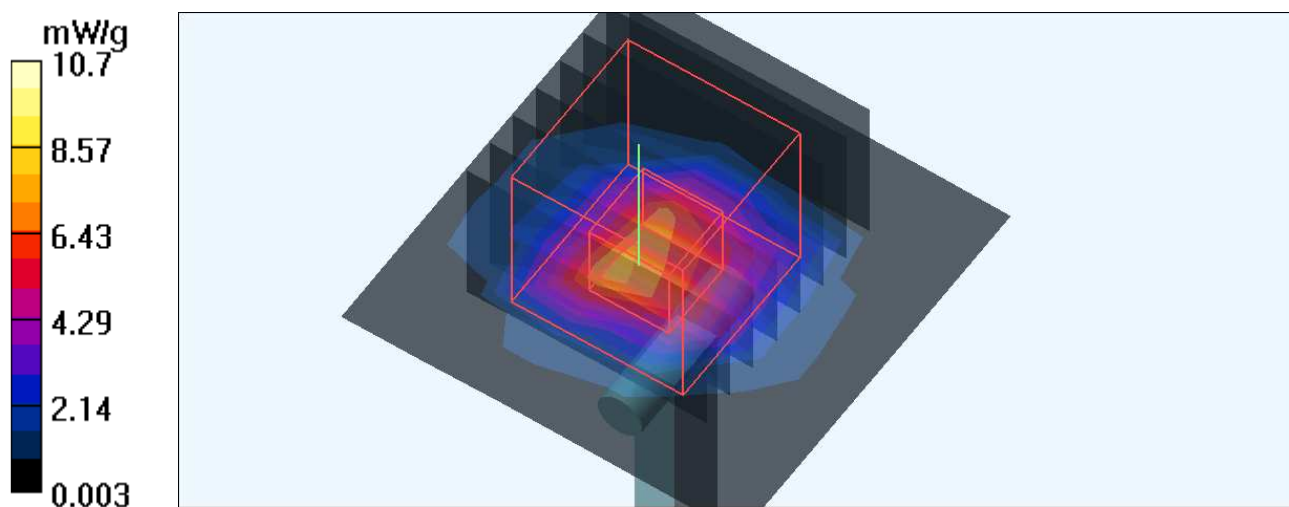

APPENDIX A: TEST DATA

Liquid Level Photo

Tissue MSL2450MHz D=152mm



Tissue MSL5800MHz D=153mm

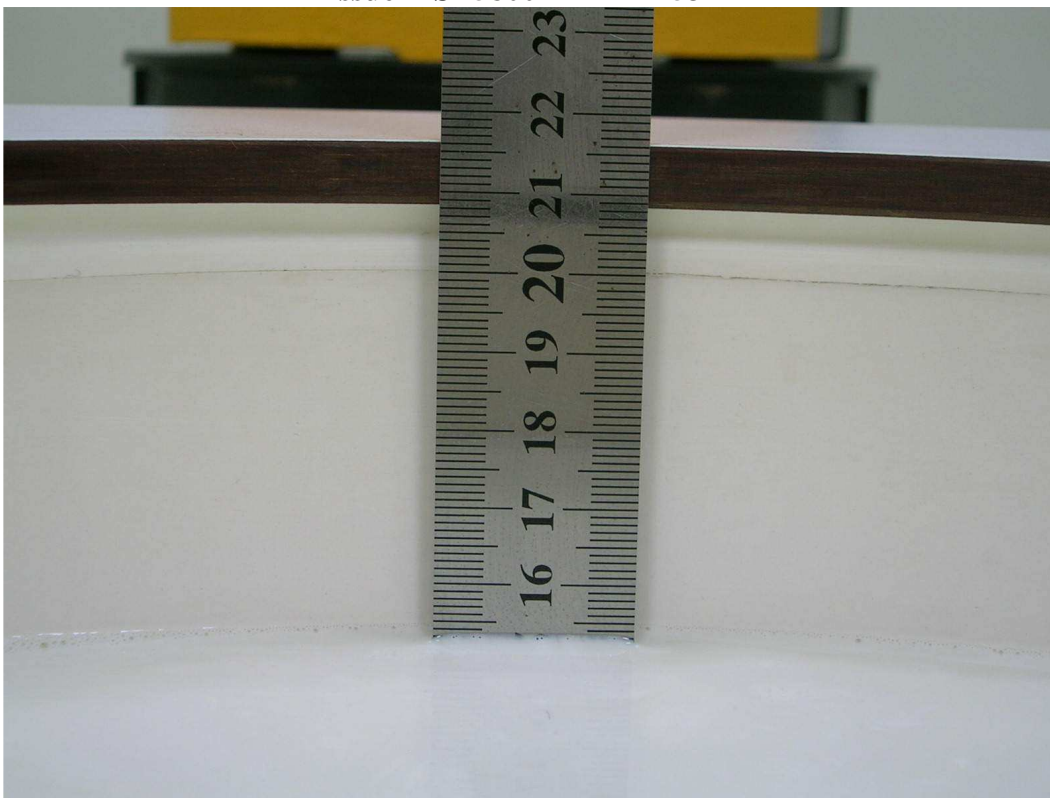

Test Laboratory: Bureau Veritas ADT

M12-1D/Body Edge-L 11B Ch1 /Main Ant

DUT: MC3190 ; Type: Gun

Communication System: 802.11b ; Frequency: 2412 MHz ; Duty Cycle: 1:1 ; Modulation type: QBPSK
Medium: MSL2450 Medium parameters used: $f = 2412$ MHz; $\sigma = 1.96$ mho/m; $\epsilon_r = 55$; $\rho = 1000$ kg/m³
Phantom section: Flat Section ; Separation distance : 0 mm (The Edge L side of the EUT with leather to the Phantom)

DASY5 Configuration:

- Probe: EX3DV4 - SN3590 ; ConvF(7.96, 7.96, 7.96) ; Calibrated: 2009/4/28
- Sensor-Surface: 3mm (Mechanical Surface Detection)
- Electronics: DAE4 Sn861 ; Calibrated: 2008/9/22
- Phantom: SAM with CRP ; Type: SAM ; Serial: TP-1485
- Measurement SW: DASY5, V5.0 Build 125 ; SEMCAD X Version 13.4 Build 125

Low Channel 1/Area Scan (6x17x1): Measurement grid: dx=15mm, dy=15mm
Maximum value of SAR (measured) = 0.058 mW/g

Low Channel 1/Zoom Scan (7x7x7) (7x7x7)/Cube 0: Measurement grid: dx=5mm, dy=5mm, dz=5mm
Reference Value = 2.23 V/m; Power Drift = -0.126 dB
Peak SAR (extrapolated) = 0.094 W/kg
SAR(1 g) = 0.050 mW/g; SAR(10 g) = 0.028 mW/g
Maximum value of SAR (measured) = 0.062 mW/g

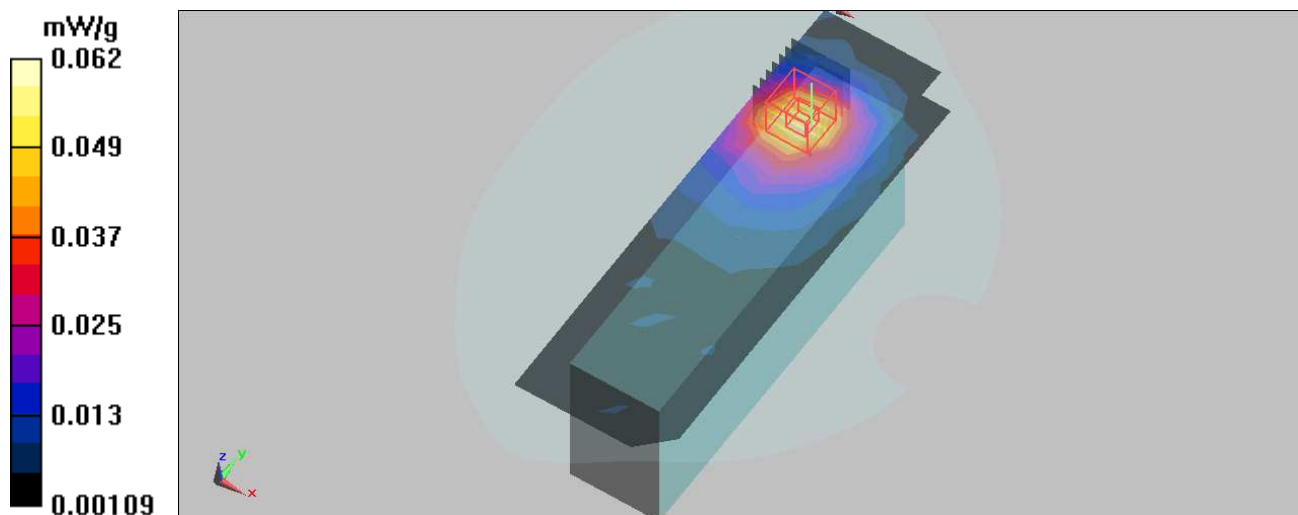

Test Laboratory: Bureau Veritas ADT

M13-1D/Body Edge-L 11G Ch6 /Main Ant

DUT: MC3190 ; Type: Gun

Communication System: 802.11g ; Frequency: 2437 MHz ; Duty Cycle: 1:1 ; Modulation type: BPSK
Medium: MSL2450 Medium parameters used: $f = 2437$ MHz; $\sigma = 1.99$ mho/m; $\epsilon_r = 54.9$; $\rho = 1000$ kg/m³
Phantom section: Flat Section ; Separation distance : 0 mm (The Edge L side of the EUT with leather to the Phantom)

DASY5 Configuration:

- Probe: EX3DV4 - SN3590 ; ConvF(7.96, 7.96, 7.96) ; Calibrated: 2009/4/28
- Sensor-Surface: 3mm (Mechanical Surface Detection)
- Electronics: DAE4 Sn861 ; Calibrated: 2008/9/22
- Phantom: SAM with CRP ; Type: SAM ; Serial: TP-1485
- Measurement SW: DASY5, V5.0 Build 125 ; SEMCAD X Version 13.4 Build 125

Mid Channel 6/Area Scan (6x17x1): Measurement grid: dx=15mm, dy=15mm
Maximum value of SAR (measured) = 0.072 mW/g

Mid Channel 6/Zoom Scan (7x7x7) (7x7x7)/Cube 0: Measurement grid: dx=5mm, dy=5mm, dz=5mm

Reference Value = 3.16 V/m; Power Drift = -0.146 dB

Peak SAR (extrapolated) = 0.107 W/kg

SAR(1 g) = 0.058 mW/g; SAR(10 g) = 0.034 mW/g

Maximum value of SAR (measured) = 0.071 mW/g

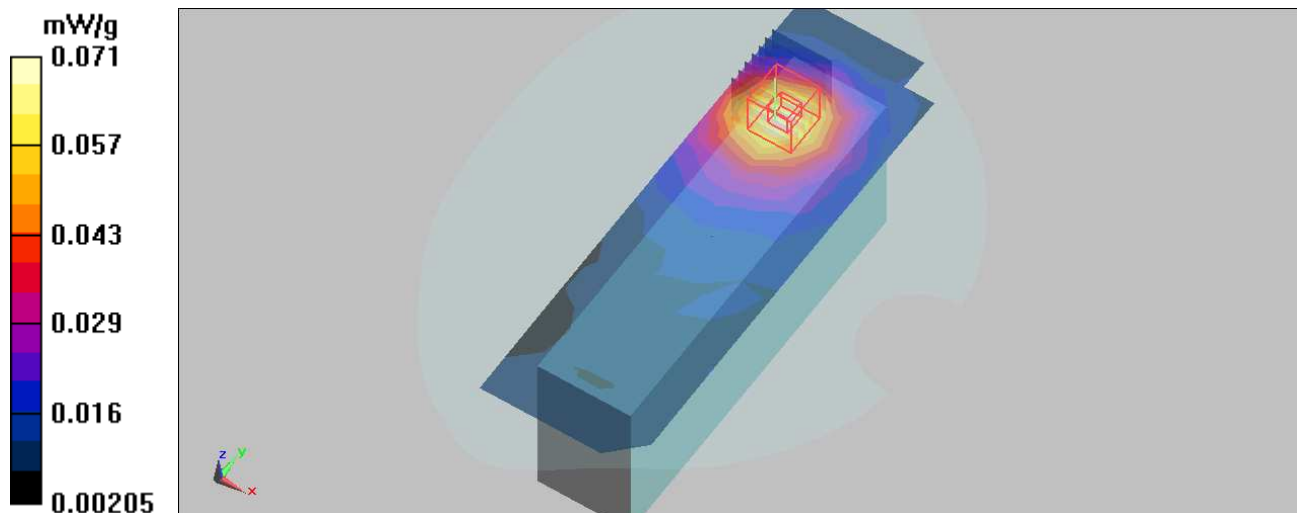

Test Laboratory: Bureau Veritas ADT

M14-1D/Body Edge-R 11G Ch6 /Aux Ant

DUT: MC3190 ; Type: Gun

Communication System: 802.11g ; Frequency: 2437 MHz ; Duty Cycle: 1:1 ; Modulation type: BPSK
Medium: MSL2450 Medium parameters used: $f = 2437$ MHz; $\sigma = 1.99$ mho/m; $\epsilon_r = 54.9$; $\rho = 1000$ kg/m³
Phantom section: Flat Section ; Separation distance : 0 mm (The Edge R side of the EUT with leather to the Phantom)

DASY5 Configuration:

- Probe: EX3DV4 - SN3590 ; ConvF(7.96, 7.96, 7.96) ; Calibrated: 2009/4/28
- Sensor-Surface: 3mm (Mechanical Surface Detection)
- Electronics: DAE4 Sn861 ; Calibrated: 2008/9/22
- Phantom: SAM with CRP ; Type: SAM ; Serial: TP-1485
- Measurement SW: DASY5, V5.0 Build 125 ; SEMCAD X Version 13.4 Build 125

Mid Channel 6/Area Scan (6x17x1): Measurement grid: dx=15mm, dy=15mm
Maximum value of SAR (measured) = 0.015 mW/g

Mid Channel 6/Zoom Scan (7x7x7) (7x7x7)/Cube 0: Measurement grid: dx=5mm, dy=5mm, dz=5mm

Reference Value = 1.07 V/m; Power Drift = -0.101 dB

Peak SAR (extrapolated) = 0.022 W/kg

SAR(1 g) = 0.011 mW/g; SAR(10 g) = 0.00682 mW/g

Maximum value of SAR (measured) = 0.014 mW/g

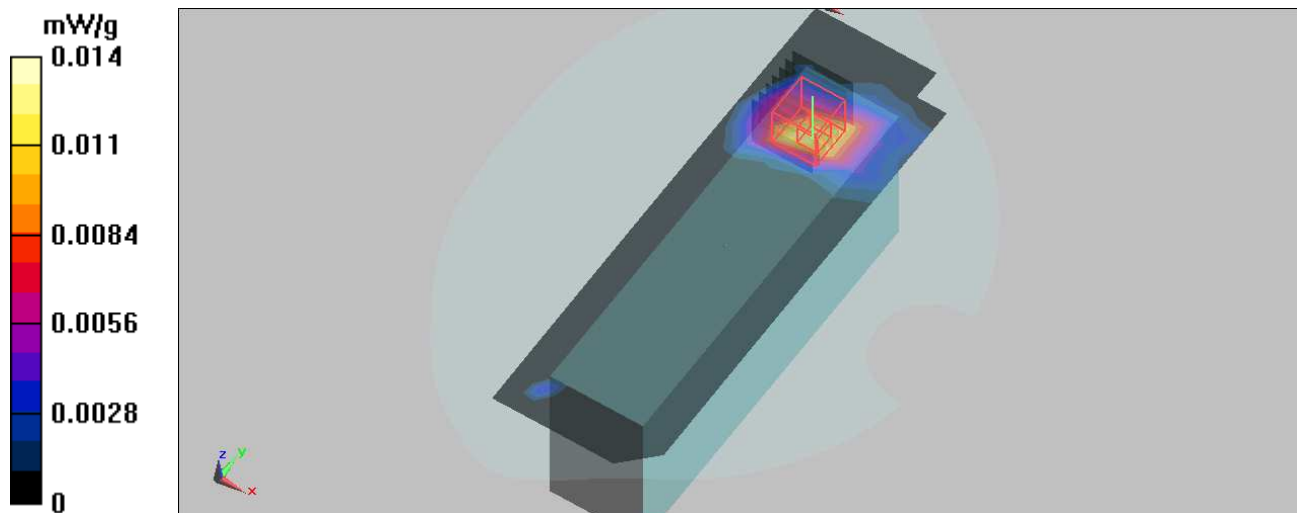

Test Laboratory: Bureau Veritas ADT

M15-2D/Body Edge-L 11G Ch6 /Main Ant

DUT: MC3190 ; Type: Gun

Communication System: 802.11g ; Frequency: 2437 MHz ; Duty Cycle: 1:1 ; Modulation type: BPSK
Medium: MSL2450 Medium parameters used: $f = 2437$ MHz; $\sigma = 1.99$ mho/m; $\epsilon_r = 54.9$; $\rho = 1000$ kg/m³
Phantom section: Flat Section ; Separation distance : 0 mm (The Edge L side of the EUT with leather to the Phantom)

DASY5 Configuration:

- Probe: EX3DV4 - SN3590 ; ConvF(7.96, 7.96, 7.96) ; Calibrated: 2009/4/28
- Sensor-Surface: 3mm (Mechanical Surface Detection)
- Electronics: DAE4 Sn861 ; Calibrated: 2008/9/22
- Phantom: SAM with CRP ; Type: SAM ; Serial: TP-1485
- Measurement SW: DASY5, V5.0 Build 125 ; SEMCAD X Version 13.4 Build 125

Mid Channel 6/Area Scan (6x17x1): Measurement grid: dx=15mm, dy=15mm
Maximum value of SAR (measured) = 0.063 mW/g

Mid Channel 6/Zoom Scan (7x7x7) (7x7x7)/Cube 0: Measurement grid: dx=5mm, dy=5mm, dz=5mm

Reference Value = 3.56 V/m; Power Drift = -0.15 dB

Peak SAR (extrapolated) = 0.088 W/kg

SAR(1 g) = 0.050 mW/g; SAR(10 g) = 0.032 mW/g

Maximum value of SAR (measured) = 0.061 mW/g

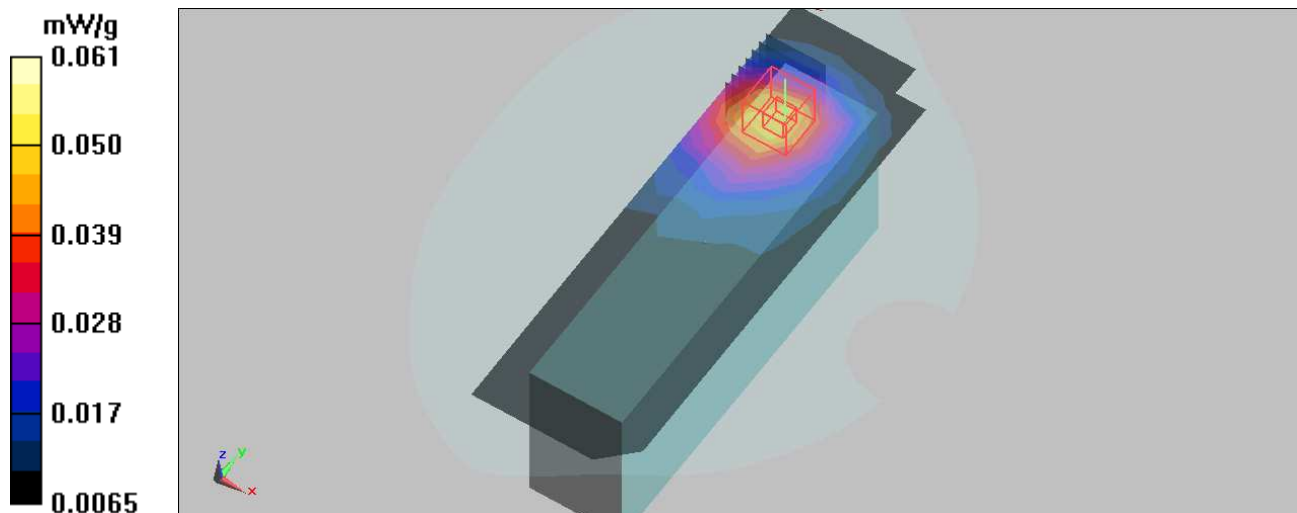

Test Laboratory: Bureau Veritas ADT

M16-1D/Body Edge-R 11A Ch149 /Aux Ant

DUT: MC3190 ; Type: Gun

Communication System: 802.11a ; Frequency: 5745 MHz ; Duty Cycle: 1:1 ; Modulation type: BPSK
Medium: MSL5800 Medium parameters used: $f = 5745 \text{ MHz}$; $\sigma = 6.19 \text{ mho/m}$; $\epsilon_r = 50.1$; $\rho = 1000 \text{ kg/m}^3$
Phantom section: Flat Section ; Separation distance : 0 mm (The Edge R side of the EUT with leather to the Phantom)

DASY5 Configuration:

- Probe: EX3DV4 - SN3590 ; ConvF(4.62, 4.62, 4.62) ; Calibrated: 2009/4/28
- Sensor-Surface: 3mm (Mechanical Surface Detection)
- Electronics: DAE4 Sn861 ; Calibrated: 2008/9/22
- Phantom: SAM with CRP ; Type: SAM ; Serial: TP-1485
- Measurement SW: DASY5, V5.0 Build 125 ; SEMCAD X Version 13.4 Build 125

Channel 149/Area Scan (9x25x1): Measurement grid: $dx=10\text{mm}$, $dy=10\text{mm}$
Maximum value of SAR (measured) = 0.445 mW/g

Channel 149/Zoom Scan (8x8x8)/Cube 0: Measurement grid: $dx=4.3\text{mm}$, $dy=4.3\text{mm}$, $dz=3\text{mm}$
Reference Value = 2.16 V/m; Power Drift = -0.149 dB
Peak SAR (extrapolated) = 1.03 W/kg
SAR(1 g) = 0.315 mW/g; SAR(10 g) = 0.129 mW/g
Maximum value of SAR (measured) = 0.436 mW/g

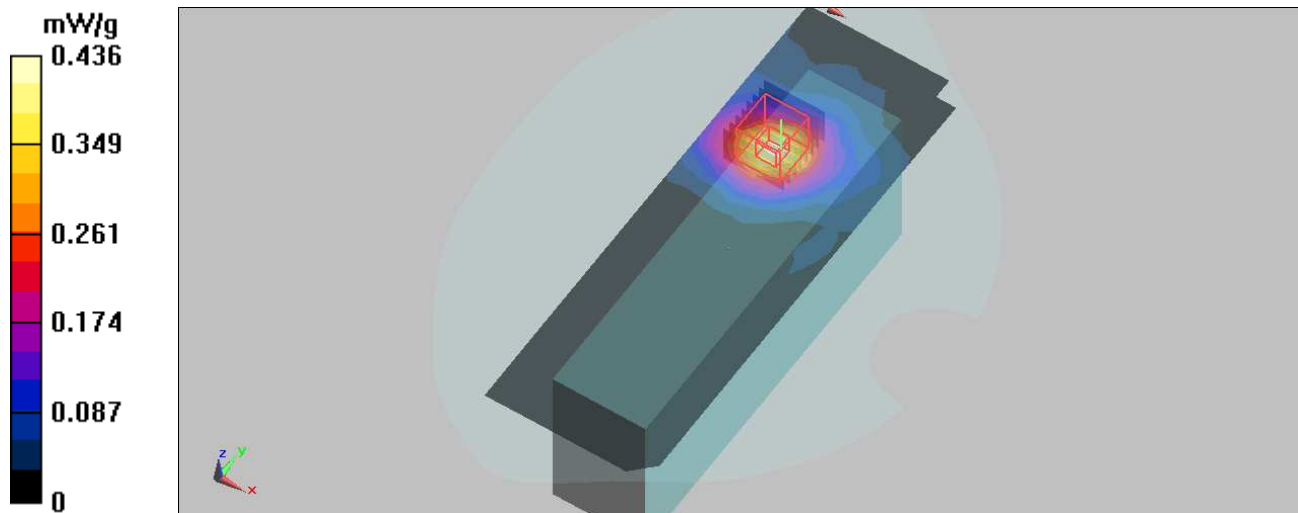

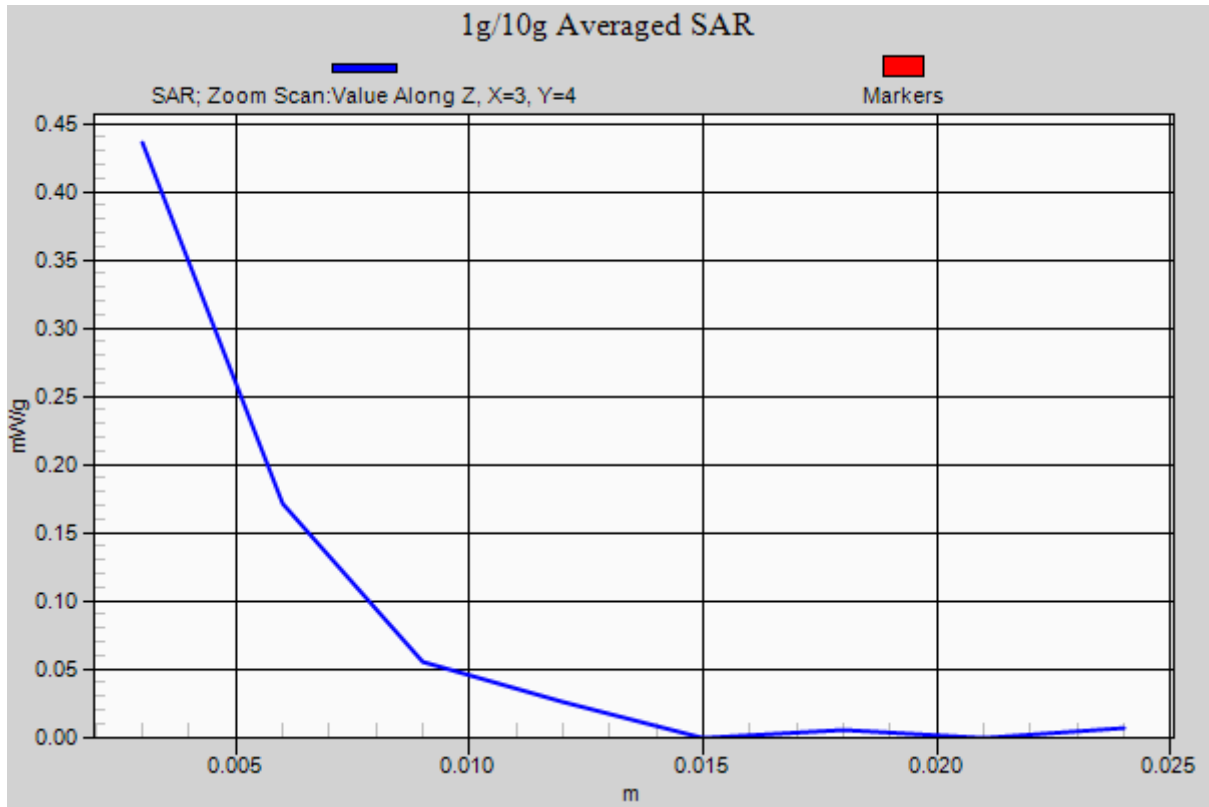

Test Laboratory: Bureau Veritas ADT

System validation MSL 2450MHz

DUT: Dipole 2450 MHz ; Type: D2450V2 ; Serial: 716 ; Test Frequency: 2450 MHz

Communication System: CW ; Frequency: 2450 MHz; Duty Cycle: 1:1; Modulation type: CW
 Medium: MSL2450; Medium parameters used: $f = 2450$ MHz; $\sigma = 2.01$ mho/m; $\epsilon_r = 54.8$; $\rho = 1000$ kg/m³ ; Liquid level : 152 mm

Phantom section: Flat Section ; Separation distance : 10 mm (The feetpoint of the dipole to the Phantom) Air temp. : 23.2 degrees ; Liquid temp. : 22.7 degrees

DASY5 Configuration:

- Probe: EX3DV4 - SN3590 ; ConvF(7.96, 7.96, 7.96) ; Calibrated: 2009/4/28
- Sensor-Surface: 3mm (Mechanical Surface Detection)
- Electronics: DAE4 Sn861; Calibrated: 2008/9/22
- Phantom: SAM with CRP; Type: SAM; Serial: TP-1485
- Measurement SW: DASY5, V5.0 Build 125; SEMCAD X Version 13.4 Build 125

d=10mm, Pin=250mW/Area Scan (5x7x1): Measurement grid: dx=15mm, dy=15mm
 Maximum value of SAR (measured) = 17.4 mW/g

d=10mm, Pin=250mW/Zoom Scan (7x7x7)/Cube 0: Measurement grid: dx=5mm, dy=5mm, dz=5mm

Reference Value = 93.7 V/m; Power Drift = 0.026 dB

Peak SAR (extrapolated) = 28.7 W/kg

SAR(1 g) = 13.8 mW/g; SAR(10 g) = 6.35 mW/g

Maximum value of SAR (measured) = 18.2 mW/g

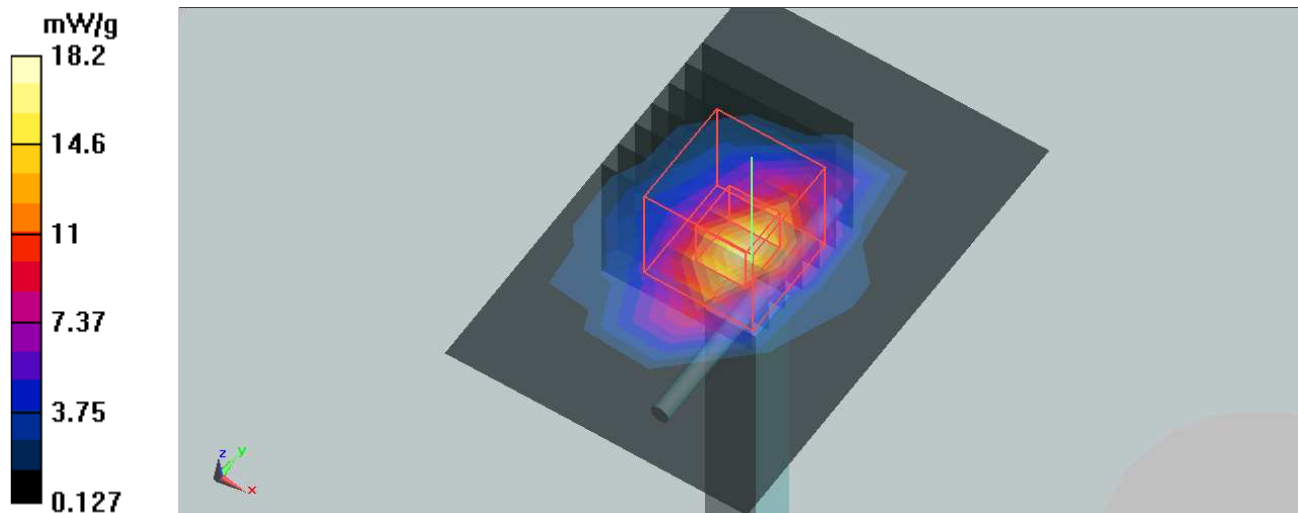

Test Laboratory: Bureau Veritas ADT

System validation MSL 5800MHz

DUT: Dipole 5 GHz ; Type: D5GHzV2 ; Serial: 1019 ; Test Frequency: 5800 MHz

Communication System: CW ; Frequency: 5800 MHz; Duty Cycle: 1:1; Modulation type: CW
 Medium: MSL5800; Medium parameters used: $f = 5800$ MHz; $\sigma = 6.26$ mho/m; $\epsilon_r = 50$; $\rho = 1000$ kg/m³ ;
 Liquid level : 153 mm
 Phantom section: Flat Section ; Separation distance : 10 mm (The feetpoint of the dipole to the Phantom)
 Air temp. : 23.1 degrees ; Liquid temp. : 22.6 degrees

DASY5 Configuration:

- Probe: EX3DV4 - SN3590 ; ConvF(4.62, 4.62, 4.62) ; Calibrated: 2009/4/28
- Sensor-Surface: 3mm (Mechanical Surface Detection)
- Electronics: DAE4 Sn861; Calibrated: 2008/9/22
- Phantom: SAM with CRP; Type: SAM; Serial: TP-1485
- Measurement SW: DASY5, V5.0 Build 125; SEMCAD X Version 13.4 Build 125

f=5800, d=10mm, Pin=100mW/Area Scan (6x6x1): Measurement grid: dx=10mm, dy=10mm
 Maximum value of SAR (measured) = 8.62 mW/g

f=5800, d=10mm, Pin=100mW/Zoom Scan (8x8x8)/Cube 0: Measurement grid: dx=4.3mm, dy=4.3mm, dz=3mm

Reference Value = 43.8 V/m; Power Drift = 0.197 dB

Peak SAR (extrapolated) = 29.5 W/kg

SAR(1 g) = 7.61 mW/g; SAR(10 g) = 2.12 mW/g

Maximum value of SAR (measured) = 10.9 mW/g

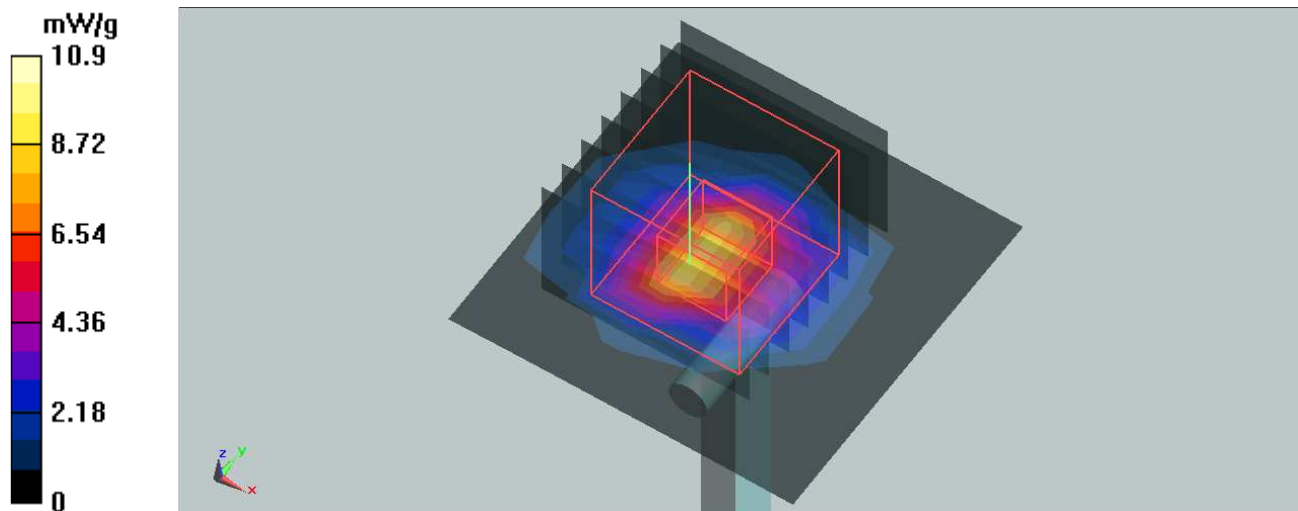

APPENDIX B: ADT SAR MEASUREMENT SYSTEM



APPENDIX C: PHOTOGRAPHS OF SYSTEM VALIDATION



APPENDIX B: BV ADT SAR MEASUREMENT SYSTEM

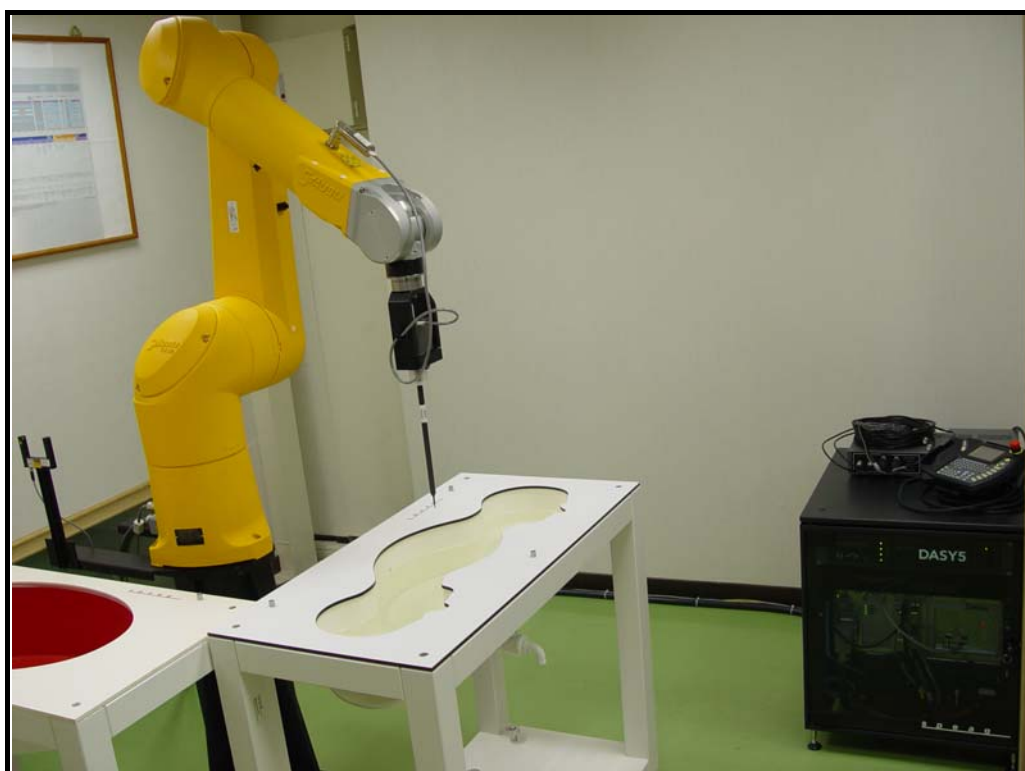

APPENDIX C: PHOTOGRAPHS OF SYSTEM VALIDATION





APPENDIX D: SYSTEM CERTIFICATE & CALIBRATION

D1: PHANTOM



APPENDIX D: SYSTEM CERTIFICATE & CALIBRATION

D1: SAM PHANTOM

Schmid & Partner Engineering AG

Zeughausstrasse 43, 8004 Zurich, Switzerland, Phone +41 1 245 97 00, Fax +41 1 245 97 79

Certificate of conformity / First Article Inspection

Item	SAM Twin Phantom V4.0
Type No	QD 000 P40 CA
Series No	TP-1150 and higher
Manufacturer / Origin	Untersee Composites Hauptstr. 69 CH-8559 Fruthwilen Switzerland

Tests

The series production process used allows the limitation to test of first articles. Complete tests were made on the pre-series Type No. QD 000 P40 AA, Serial No. TP-1001 and on the series first article Type No. QD 000 P40 BA, Serial No. TP-1006. Certain parameters have been retested using further series units (called samples).

Test	Requirement	Details	Units tested
Shape	Compliance with the geometry according to the CAD model.	IT'IS CAD File (*)	First article, Samples
Material thickness	Compliant with the requirements according to the standards	2mm +/- 0.2mm in specific areas	First article, Samples
Material parameters	Dielectric parameters for required frequencies	200 MHz - 3 GHz Relative permittivity < 5 Loss tangent < 0.05.	Material sample TP 104-5
Material resistivity	The material has been tested to be compatible with the liquids defined in the standards	Liquid type HSL 1800 and others according to the standard.	Pre-series, First article

Standards

- [1] CENELEC EN 50361
- [2] IEEE P1528-200x draft 6.5
- [3] IEC PT 62209 draft 0.9

(*) The IT'IS CAD file is derived from [2] and is also within the tolerance requirements of the shapes of [1] and [3].

Conformity

Based on the sample tests above, we certify that this item is in compliance with the uncertainty requirements of SAR measurements specified in standard [1] and draft standards [2] and [3].

Date

28.02.2002

Signature / Stamp

F. Bumbult

**Schmid & Partner
Engineering AG**

Zeughausstrasse 43, CH-8004 Zurich
Tel. +41 1 245 97 00, Fax +41 1 245 97 79

Volker Kapp

Certificate of Conformity / First Article Inspection

Item	SAM Twin Phantom V4.0
Type No	QD 000 P40 C
Series No	TP-1150 and higher
Manufacturer	SPEAG Zeughausstrasse 43 CH-8004 Zürich Switzerland

Tests

The series production process used allows the limitation to test of first articles. Complete tests were made on the pre-series Type No. QD 000 P40 AA, Serial No. TP-1001 and on the series first article Type No. QD 000 P40 BA, Serial No. TP-1006. Certain parameters have been retested using further series items (called samples) or are tested at each item.

Test	Requirement	Details	Units tested
Dimensions	Compliant with the geometry according to the CAD model.	IT'IS CAD File (*)	First article, Samples
Material thickness of shell	Compliant with the requirements according to the standards	2mm +/- 0.2mm in flat and specific areas of head section	First article, Samples, TP-1314 ff.
Material thickness at ERP	Compliant with the requirements according to the standards	6mm +/- 0.2mm at ERP	First article, All items
Material parameters	Dielectric parameters for required frequencies	300 MHz – 6 GHz: Relative permittivity < 5, Loss tangent < 0.05	Material samples
Material resistivity	The material has been tested to be compatible with the liquids defined in the standards if handled and cleaned according to the instructions. Observe technical Note for material compatibility.	DEGMBE based simulating liquids	Pre-series, First article, Material samples
Sagging	Compliant with the requirements according to the standards. Sagging of the flat section when filled with tissue simulating liquid.	< 1% typical < 0.8% if filled with 155mm of HSL900 and without DUT below	Prototypes, Sample testing

Standards

- [1] CENELEC EN 50361
- [2] IEEE Std 1528-2003
- [3] IEC 62209 Part I
- [4] FCC OET Bulletin 65, Supplement C, Edition 01-01

(*) The IT'IS CAD file is derived from [2] and is also within the tolerance requirements of the shapes of the other documents.

Conformity

Based on the sample tests above, we certify that this item is in compliance with the uncertainty requirements of SAR measurements specified in standards [1] to [4].

Date 07.07.2005

Signature / Stamp



D2: DOSIMETRIC E-FIELD PROBE



Accredited by the Swiss Accreditation Service (SAS)
The Swiss Accreditation Service is one of the signatories to the EA
Multilateral Agreement for the recognition of calibration certificates

Accreditation No.: **SCS 108**

Client **ADT (Auden)**

Certificate No: **EX3-3504_Jan09**

CALIBRATION CERTIFICATE

Object **EX3DV3 - SN:3504**

Calibration procedure(s) **QA CAL-01.v6, QA CAL-14.v3 and QA CAL-23.v3
Calibration procedure for dosimetric E-field probes**

Calibration date: **January 21, 2009**

Condition of the calibrated item **In Tolerance**

This calibration certificate documents the traceability to national standards, which realize the physical units of measurements (SI).
The measurements and the uncertainties with confidence probability are given on the following pages and are part of the certificate.

All calibrations have been conducted in the closed laboratory facility: environment temperature (22 ± 3)°C and humidity < 70%.

Calibration Equipment used (M&TE critical for calibration)

Primary Standards	ID #	Cal Date (Certificate No.)	Scheduled Calibration
Power meter E4419B	GB41293874	1-Apr-08 (No. 217-00788)	Apr-09
Power sensor E4412A	MY41495277	1-Apr-08 (No. 217-00788)	Apr-09
Power sensor E4412A	MY41498087	1-Apr-08 (No. 217-00788)	Apr-09
Reference 3 dB Attenuator	SN: S5054 (3c)	1-Jul-08 (No. 217-00865)	Jul-09
Reference 20 dB Attenuator	SN: S5086 (20b)	31-Mar-08 (No. 217-00787)	Apr-09
Reference 30 dB Attenuator	SN: S5129 (30b)	1-Jul-08 (No. 217-00866)	Jul-09
Reference Probe ES3DV2	SN: 3013	2-Jan-09 (No. ES3-3013_Jan09)	Jan-10
DAE4	SN: 660	9-Sep-08 (No. DAE4-660_Sep08)	Sep-09

Secondary Standards	ID #	Check Date (in house)	Scheduled Check
RF generator HP 8648C	US3642U01700	4-Aug-99 (in house check Oct-07)	In house check: Oct-09
Network Analyzer HP 8753E	US37390585	18-Oct-01 (in house check Oct-08)	In house check: Oct-09

	Name	Function	Signature
Calibrated by:	Katja Pokovic	Technical Manager	
Approved by:	Niels Kuster	Quality Manager	

Issued: January 21, 2009

This calibration certificate shall not be reproduced except in full without written approval of the laboratory.



Accredited by the Swiss Accreditation Service (SAS)

The Swiss Accreditation Service is one of the signatories to the EA
Multilateral Agreement for the recognition of calibration certificates

Accreditation No.: **SCS 108**

Glossary:

TSL	tissue simulating liquid
NORM _{x,y,z}	sensitivity in free space
ConvF	sensitivity in TSL / NORM _{x,y,z}
DCP	diode compression point
Polarization φ	φ rotation around probe axis
Polarization ϑ	ϑ rotation around an axis that is in the plane normal to probe axis (at measurement center), i.e., $\vartheta = 0$ is normal to probe axis

Calibration is Performed According to the Following Standards:

- IEEE Std 1528-2003, "IEEE Recommended Practice for Determining the Peak Spatial-Averaged Specific Absorption Rate (SAR) in the Human Head from Wireless Communications Devices: Measurement Techniques", December 2003
- IEC 62209-1, "Procedure to measure the Specific Absorption Rate (SAR) for hand-held devices used in close proximity to the ear (frequency range of 300 MHz to 3 GHz)", February 2005

Methods Applied and Interpretation of Parameters:

- NORM_{x,y,z}**: Assessed for E-field polarization $\vartheta = 0$ ($f \leq 900$ MHz in TEM-cell; $f > 1800$ MHz: R22 waveguide). NORM_{x,y,z} are only intermediate values, i.e., the uncertainties of NORM_{x,y,z} does not effect the E²-field uncertainty inside TSL (see below *ConvF*).
- NORM(*f*)_{x,y,z}** = NORM_{x,y,z} * *frequency_response* (see Frequency Response Chart). This linearization is implemented in DASY4 software versions later than 4.2. The uncertainty of the frequency response is included in the stated uncertainty of *ConvF*.
- DCP_{x,y,z}**: DCP are numerical linearization parameters assessed based on the data of power sweep (no uncertainty required). DCP does not depend on frequency nor media.
- ConvF and Boundary Effect Parameters**: Assessed in flat phantom using E-field (or Temperature Transfer Standard for $f \leq 800$ MHz) and inside waveguide using analytical field distributions based on power measurements for $f > 800$ MHz. The same setups are used for assessment of the parameters applied for boundary compensation (alpha, depth) of which typical uncertainty values are given. These parameters are used in DASY4 software to improve probe accuracy close to the boundary. The sensitivity in TSL corresponds to NORM_{x,y,z} * *ConvF* whereby the uncertainty corresponds to that given for *ConvF*. A frequency dependent *ConvF* is used in DASY version 4.4 and higher which allows extending the validity from ± 50 MHz to ± 100 MHz.
- Spherical isotropy (3D deviation from isotropy)**: in a field of low gradients realized using a flat phantom exposed by a patch antenna.
- Sensor Offset**: The sensor offset corresponds to the offset of virtual measurement center from the probe tip (on probe axis). No tolerance required.

Probe EX3DV3

SN:3504

Manufactured:	December 15, 2003
Last calibrated:	August 30, 2007
Recalibrated:	January 21, 2009

Calibrated for DASY Systems

(Note: non-compatible with DASY2 system!)

DASY - Parameters of Probe: EX3DV3 SN:3504

Sensitivity in Free Space ^A			Diode Compression ^B	
NormX	0.60 ± 10.1%	$\mu\text{V}/(\text{V}/\text{m})^2$	DCP X	94 mV
NormY	0.62 ± 10.1%	$\mu\text{V}/(\text{V}/\text{m})^2$	DCP Y	94 mV
NormZ	0.65 ± 10.1%	$\mu\text{V}/(\text{V}/\text{m})^2$	DCP Z	95 mV

Sensitivity in Tissue Simulating Liquid (Conversion Factors)

Please see Page 8.

Boundary Effect

TSL 900 MHz Typical SAR gradient: 5 % per mm

		2.0 mm	3.0 mm
Sensor Center to Phantom Surface Distance			
SAR _{be} [%]	Without Correction Algorithm	10.0	6.0
SAR _{be} [%]	With Correction Algorithm	0.7	0.3

TSL 1750 MHz Typical SAR gradient: 10 % per mm

		2.0 mm	3.0 mm
Sensor Center to Phantom Surface Distance			
SAR _{be} [%]	Without Correction Algorithm	8.0	4.9
SAR _{be} [%]	With Correction Algorithm	0.8	0.6

Sensor Offset

Probe Tip to Sensor Center **1.0** mm

The reported uncertainty of measurement is stated as the standard uncertainty of measurement multiplied by the coverage factor k=2, which for a normal distribution corresponds to a coverage probability of approximately 95%.

^A The uncertainties of NormX,Y,Z do not affect the E²-field uncertainty inside TSL (see Page 8).

^B Numerical linearization parameter: uncertainty not required.

Frequency Response of E-Field

(TEM-Cell:ifi110 EXX, Waveguide: R22)

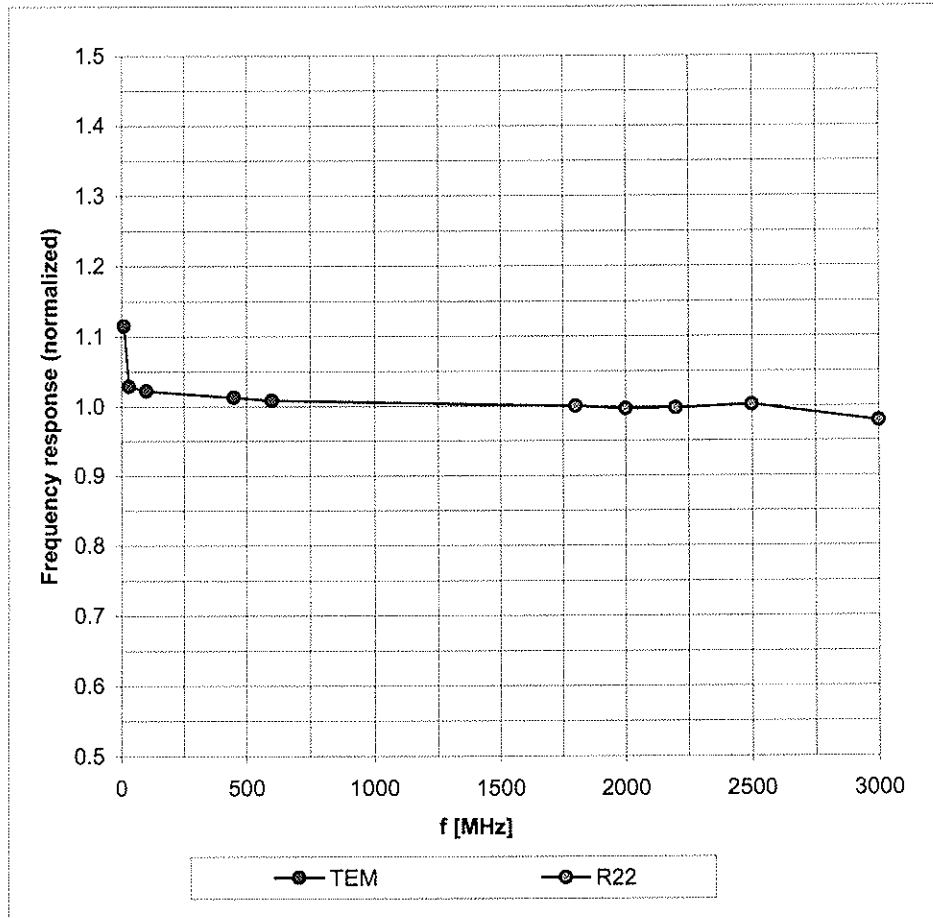

Uncertainty of Frequency Response of E-field: $\pm 6.3\%$ ($k=2$)

Receiving Pattern (ϕ), $\vartheta = 0^\circ$

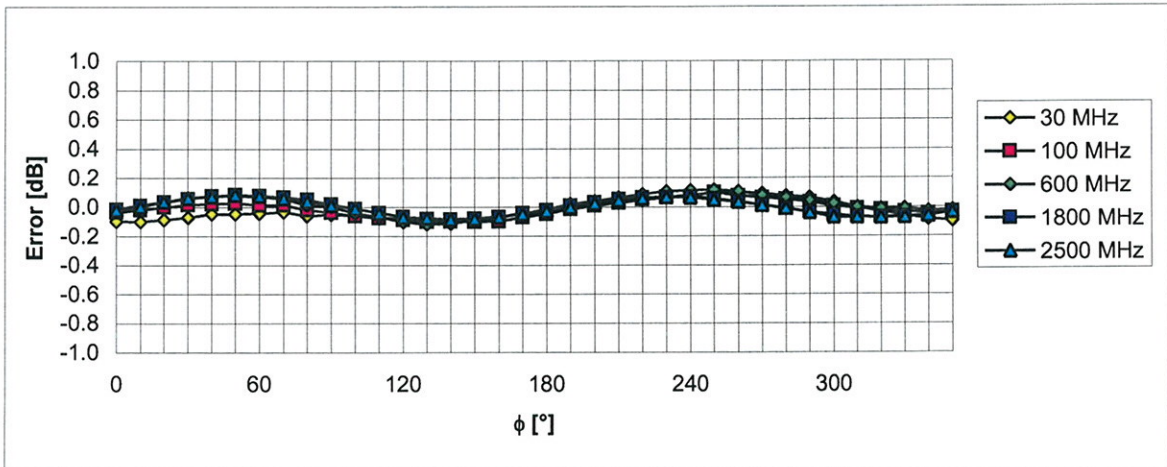
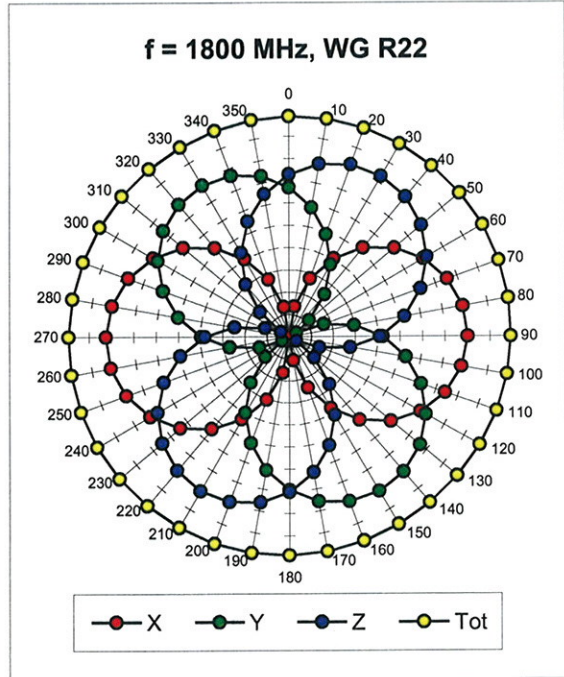
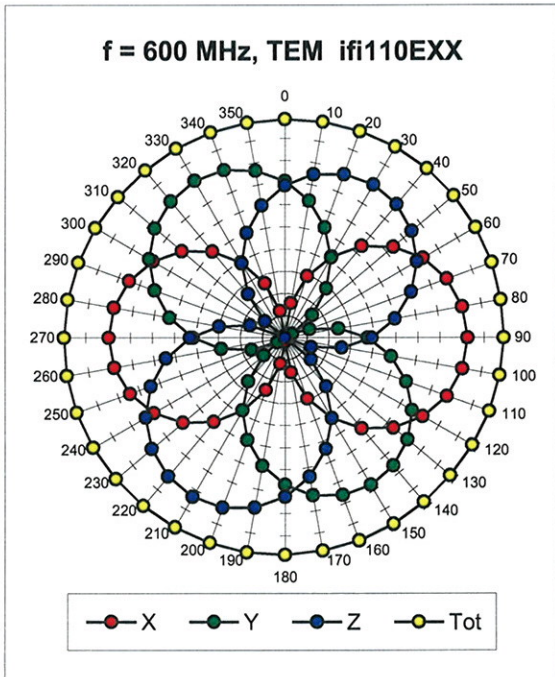

Uncertainty of Axial Isotropy Assessment: $\pm 0.5\%$ ($k=2$)

Dynamic Range f(SAR_{head}) (Waveguide R22, f = 1800 MHz)

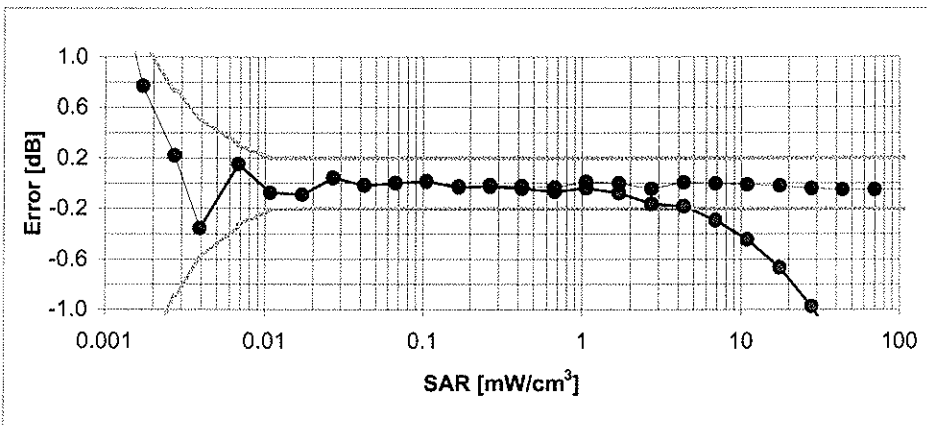
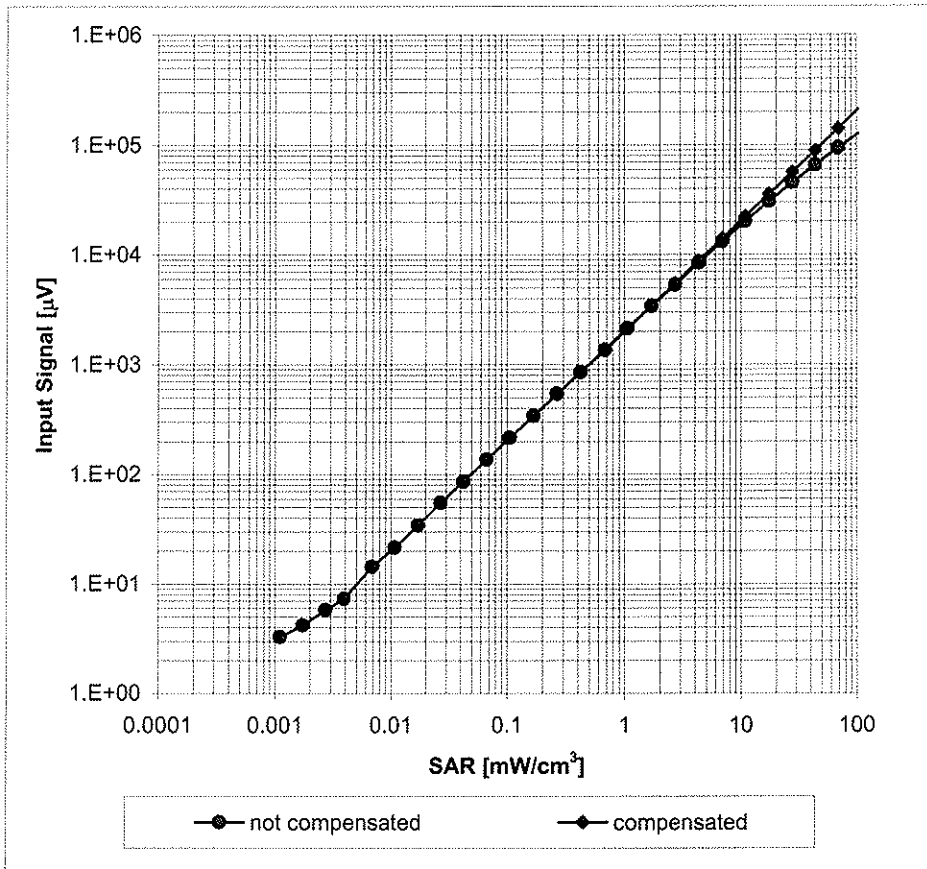

Uncertainty of Linearity Assessment: ± 0.6% (k=2)

Conversion Factor Assessment

f [MHz]	Validity [MHz] ^c	TSL	Permittivity	Conductivity	Alpha	Depth	ConvF Uncertainty
900	± 50 / ± 100	Head	41.5 ± 5%	0.97 ± 5%	0.74	0.65	9.57 ± 11.0% (k=2)
1750	± 50 / ± 100	Head	40.1 ± 5%	1.37 ± 5%	0.56	0.64	8.53 ± 11.0% (k=2)
1950	± 50 / ± 100	Head	40.0 ± 5%	1.40 ± 5%	0.76	0.57	8.08 ± 11.0% (k=2)
2450	± 50 / ± 100	Head	39.2 ± 5%	1.80 ± 5%	0.53	0.66	7.67 ± 11.0% (k=2)
2600	± 50 / ± 100	Head	39.0 ± 5%	1.96 ± 5%	0.24	0.98	7.56 ± 11.0% (k=2)
5200	± 50 / ± 100	Head	36.0 ± 5%	4.66 ± 5%	0.42	1.70	4.65 ± 13.1% (k=2)
5300	± 50 / ± 100	Head	35.9 ± 5%	4.76 ± 5%	0.42	1.70	4.49 ± 13.1% (k=2)
5500	± 50 / ± 100	Head	35.6 ± 5%	4.96 ± 5%	0.42	1.70	4.39 ± 13.1% (k=2)
5600	± 50 / ± 100	Head	35.5 ± 5%	5.07 ± 5%	0.42	1.70	4.29 ± 13.1% (k=2)
5800	± 50 / ± 100	Head	35.3 ± 5%	5.27 ± 5%	0.42	1.70	4.40 ± 13.1% (k=2)
900	± 50 / ± 100	Body	55.0 ± 5%	1.05 ± 5%	0.50	0.73	9.71 ± 11.0% (k=2)
1750	± 50 / ± 100	Body	53.4 ± 5%	1.49 ± 5%	0.46	0.73	8.36 ± 11.0% (k=2)
1950	± 50 / ± 100	Body	53.3 ± 5%	1.52 ± 5%	0.43	0.73	8.21 ± 11.0% (k=2)
2450	± 50 / ± 100	Body	52.7 ± 5%	1.95 ± 5%	0.27	1.07	7.53 ± 11.0% (k=2)
2600	± 50 / ± 100	Body	52.5 ± 5%	2.16 ± 5%	0.25	1.10	7.33 ± 11.0% (k=2)
5200	± 50 / ± 100	Body	49.0 ± 5%	5.30 ± 5%	0.45	1.75	4.38 ± 13.1% (k=2)
5300	± 50 / ± 100	Body	48.9 ± 5%	5.42 ± 5%	0.45	1.75	4.06 ± 13.1% (k=2)
5500	± 50 / ± 100	Body	48.6 ± 5%	5.65 ± 5%	0.42	1.75	3.98 ± 13.1% (k=2)
5600	± 50 / ± 100	Body	48.5 ± 5%	5.77 ± 5%	0.42	1.75	3.91 ± 13.1% (k=2)
5800	± 50 / ± 100	Body	48.2 ± 5%	6.00 ± 5%	0.42	1.75	3.98 ± 13.1% (k=2)

^c The validity of ± 100 MHz only applies for DASY v4.4 and higher (see Page 2). The uncertainty is the RSS of the ConvF uncertainty at calibration frequency and the uncertainty for the indicated frequency band.

Deviation from Isotropy in HSL

Error (ϕ, ϑ), $f = 900$ MHz

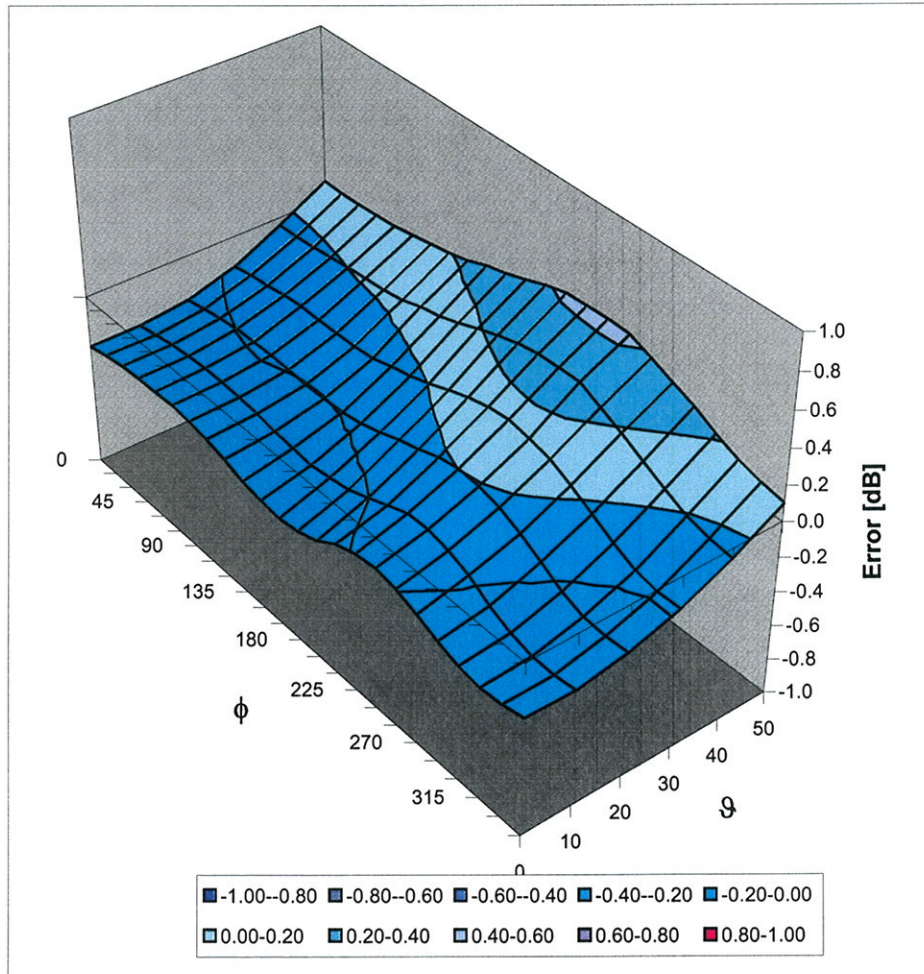

Uncertainty of Spherical Isotropy Assessment: $\pm 2.6\%$ ($k=2$)