



FCC RADIO TEST REPORT

FCC ID : UZ7MC27BJ
Equipment : Mobile computer
Brand Name : Zebra
Model Name : MC27BJ
Applicant : Zebra Technologies Corporation
1 Zebra Plaza, Holtsville, NY 11742
Manufacturer : Zebra Technologies Corporation
1 Zebra Plaza, Holtsville, NY 11742
Standard : FCC Part 15 Subpart C §15.247

The product was received on Jul. 30, 2020 and testing was started from Aug. 04, 2020 and completed on Sep. 29, 2020. We, SPORTON INTERNATIONAL INC., EMC & Wireless Communications Laboratory, would like to declare that the tested sample has been evaluated in accordance with the test procedures and has been in compliance with the applicable technical standards.

The test results in this variant report apply exclusively to the tested model / sample. Without written approval of SPORTON INTERNATIONAL INC. EMC & Wireless Communications Laboratory, the test report shall not be reproduced except in full.

Louis Wu

Approved by: Louis Wu

SPORTON INTERNATIONAL INC. EMC & Wireless Communications Laboratory

No. 52, Huaya 1st Rd., Guishan Dist., Taoyuan City, Taiwan (R.O.C.)



Table of Contents

History of this test report..... 3

Summary of Test Result..... 4

1 General Description 5

 1.1 Product Feature of Equipment Under Test..... 5

 1.2 Product Specification of Equipment Under Test..... 6

 1.3 Modification of EUT 6

 1.4 Testing Location 7

 1.5 Applicable Standards..... 7

2 Test Configuration of Equipment Under Test 8

 2.1 Carrier Frequency and Channel 8

 2.2 Test Mode..... 8

 2.3 Connection Diagram of Test System..... 12

 2.4 EUT Operation Test Setup 12

3 Test Result 13

 3.1 Output Power Measurement..... 13

 3.2 Radiated Band Edges and Spurious Emission Measurement 16

 3.3 Antenna Requirements 20

4 List of Measuring Equipment..... 21

5 Uncertainty of Evaluation 22

Appendix A. Radiated Spurious Emission

Appendix B. Radiated Spurious Emission Plots

Appendix C. Duty Cycle Plots

Appendix D. Setup Photographs

Appendix E. Original Report



Summary of Test Result

Report Clause	Ref Std. Clause	Test Items	Result (PASS/FAIL)	Remark
-	15.247(a)(2)	6dB Bandwidth	Not Required	-
-	2.1049	99% Occupied Bandwidth	Not Required	-
3.1	15.247(b)	Power Output Measurement	Pass	-
-	15.247(e)	Power Spectral Density	Not Required	-
-	15.247(d)	Conducted Band Edges	Not Required	-
		Conducted Spurious Emission	Not Required	-
3.2	15.247(d)	Radiated Band Edges and Radiated Spurious Emission	Pass	Under limit 6.13 dB at 2483.520 MHz
-	15.207	AC Conducted Emission	Not Required	-
3.3	15.203 & 15.247(b)	Antenna Requirement	Pass	-

Note: Not required means after assessing, test items are not necessary to carry out.

Declaration of Conformity:

The test results with all measurement uncertainty excluded are presented in accordance with the regulation limits or requirements declared by manufacturers.

Comments and Explanations:

The declared of product specification for EUT presented in the report are provided by the manufacturer, and the manufacturer takes all the responsibilities for the accuracy of product specification.

Reviewed by: Wii Chang

Report Producer: Celery Wei



1 General Description

1.1 Product Feature of Equipment Under Test

Product Feature	
Equipment	Mobile computer
Brand Name	Zebra
Model Name	MC27BJ
FCC ID	UZ7MC27BJ
EUT supports Radios application	GSM/EGPRS/WCDMA/HSPA/LTE/GNSS WLAN 11a/b/g/n HT20/HT40 WLAN 11ac VHT20/VHT40/VHT80 Bluetooth BR/EDR/LE
HW Version	EV
SW Version	10-11-31.00-QG-U00-PRD-HEL-04
OS Version	Android 10
MFD	02JUN20
EUT Stage	Engineering Sample

Remark: The above EUT's information was declared by manufacturer.

Specification of Accessories				
AC Adapter	Brand Name	Zebra	Part Number	PWR-WUA5V12W0US
Battery	Brand Name	Zebra	Part Number	BT-000418-10
USB Cable (TypeA plug to TypeC plug)	Brand Name	Zebra	Part Number	CBL-TC2X-USBC-01
Trigger Handle	Brand Name	Zebra	Part Number	TRG-MC2X-SNP1-01
Holster	Brand Name	Zebra	Part Number	SG-MC2X-HLSTR-01
Holster	Brand Name	Zebra	Part Number	SG-MC3021212-01R



1.2 Product Specification of Equipment Under Test

Product Specification subjective to this standard	
Tx/Rx Channel Frequency Range	2412 MHz ~ 2462 MHz
Maximum (Peak) Output Power to antenna	802.11b : 23.02 dBm (0.2004 W) 802.11g : 23.86 dBm (0.2432 W) 802.11n HT20 : 24.19 dBm (0.2624 W) 802.11n HT40 : 22.67 dBm (0.1849 W) 802.11ac VHT20 : 24.09 dBm (0.2564 W) 802.11ac VHT40 : 22.65 dBm (0.1841 W)
Maximum (Average) Output Power to antenna	802.11b : 21.20 dBm (0.1318 W) 802.11g : 20.30 dBm (0.1072 W) 802.11n HT20 : 20.60 dBm (0.1148 W) 802.11n HT40 : 16.70 dBm (0.0468 W) 802.11ac VHT20 : 20.50 dBm (0.1122 W) 802.11ac VHT40 : 16.60 dBm (0.0457 W)
Antenna Type / Gain	PIFA Antenna with gain 2.31 dBi
Type of Modulation	802.11b : DSSS (DBPSK / DQPSK / CCK) 802.11g/n : OFDM (BPSK / QPSK / 16QAM / 64QAM) 802.11ac: OFDM (BPSK / QPSK / 16QAM / 64QAM / 256QAM)

1.3 Modification of EUT

No modifications are made to the EUT during all test items.



1.4 Testing Location

Test Site	SPORTON INTERNATIONAL INC. EMC & Wireless Communications Laboratory	
Test Site Location	No.52, Huaya 1st Rd., Guishan Dist., Taoyuan City, Taiwan (R.O.C.) TEL: +886-3-327-3456 FAX: +886-3-328-4978	
Test Site No.	Sporton Site No.	
	TH05-HY	03CH07-HY

Note: The test site complies with ANSI C63.4 2014 requirement.

FCC designation No.: TW1190

1.5 Applicable Standards

According to the specifications of the manufacturer, the EUT must comply with the requirements of the following standards:

- ♦ FCC Part 15 Subpart C §15.247
- ♦ FCC KDB Publication No. 558074 D01 DTS Meas. Guidance v05r02
- ♦ FCC KDB 414788 D01 Radiated Test Site v01r01.
- ♦ ANSI C63.10-2013

Remark:

1. All test items were verified and recorded according to the standards and without any deviation during the test.
2. The TAF code is not including all the FCC KDB listed without accreditation.
3. This EUT has also been tested and complied with the requirements of FCC Part 15, Subpart B, recorded in a separate test report.



2 Test Configuration of Equipment Under Test

The EUT has been associated with peripherals and configuration operated in a manner tended to maximize its emission characteristics in a typical application. Frequency range investigated: radiation emission (9 kHz to the 10th harmonic of the highest fundamental frequency or to 40 GHz, whichever is lower). For radiated measurement, pre-scanned in three orthogonal panels, X, Y, Z. The worst cases (X plane) were recorded in this report.

2.1 Carrier Frequency and Channel

Frequency Band	Channel	Freq. (MHz)	Channel	Freq. (MHz)
2400-2483.5 MHz	1	2412	7	2442
	2	2417	8	2447
	3	2422	9	2452
	4	2427	10	2457
	5	2432	11	2462
	6	2437		

2.2 Test Mode

Final test modes are considering the modulation and worse data rates as below table.

Modulation	Data Rate
802.11b	1 Mbps
802.11g	6 Mbps
802.11n HT20	MCS0
802.11n HT40	MCS0
802.11ac VHT20	MCS0
802.11ac VHT40	MCS0

Ch. #	2400-2483.5 MHz		
	802.11b	802.11g	802.11ac VHT40
Low	-	-	-
Middle	-	-	-
High	11	11	09

Remark: For radiation spurious emission, the final modulation and the worst data rate was reference the max RF conducted power.



802.11b RF Peak Output Power (dBm)		
Power vs. Channel		
Channel	Frequency (MHz)	Data Rate (bps)
		1M
CH 01	2412	23.02
CH 06	2437	22.92
CH 11	2462	22.99

802.11g RF Peak Output Power (dBm)		
Power vs. Channel		
Channel	Frequency (MHz)	Data Rate (bps)
		6M
CH 01	2412	22.36
CH 06	2437	23.86
CH 11	2462	22.03

802.11n HT20 RF Peak Output Power (dBm)		
Power vs. Channel		
Channel	Frequency (MHz)	MCS Index
		MCS 0
CH 01	2412	21.46
CH 06	2437	24.19
CH 11	2462	21.59

802.11n HT40 RF Peak Output Power (dBm)		
Power vs. Channel		
Channel	Frequency (MHz)	MCS Index
		MCS 0
CH 03	2422	19.55
CH 06	2437	22.67
CH 09	2452	21.85



802.11ac VHT20 RF Peak Output Power (dBm)		
Power vs. Channel		
Channel	Frequency (MHz)	MCS Index
		MCS 0
CH 01	2412	21.45
CH 06	2437	24.09
CH 11	2462	21.58

802.11ac VHT40 RF Peak Output Power (dBm)		
Power vs. Channel		
Channel	Frequency (MHz)	MCS Index
		MCS 0
CH 03	2422	19.53
CH 06	2437	22.65
CH 09	2452	21.85

802.11b RF Avg Output Power (dBm)		
Power vs. Channel		
Channel	Frequency (MHz)	Data Rate (bps)
		1M
CH 01	2412	21.20
CH 06	2437	21.10
CH 11	2462	21.10

802.11g RF Avg Output Power (dBm)		
Power vs. Channel		
Channel	Frequency (MHz)	Data Rate (bps)
		6M
CH 01	2412	18.30
CH 06	2437	20.30
CH 11	2462	17.80



802.11n HT20 RF Avg Output Power (dBm)		
Power vs. Channel		
Channel	Frequency (MHz)	MCS Index
		MCS 0
CH 01	2412	17.10
CH 06	2437	20.60
CH 11	2462	17.20

802.11n HT40 RF Avg Output Power (dBm)		
Power vs. Channel		
Channel	Frequency (MHz)	MCS Index
		MCS 0
CH 03	2422	14.10
CH 06	2437	16.70
CH 09	2452	16.10

802.11ac VHT20 RF Avg Output Power (dBm)		
Power vs. Channel		
Channel	Frequency (MHz)	MCS Index
		MCS 0
CH 01	2412	17.00
CH 06	2437	20.50
CH 11	2462	17.10

802.11ac VHT40 RF Avg Output Power (dBm)		
Power vs. Channel		
Channel	Frequency (MHz)	MCS Index
		MCS 0
CH 03	2422	14.00
CH 06	2437	16.60
CH 09	2452	16.10

2.3 Connection Diagram of Test System

<WLAN Tx Mode>

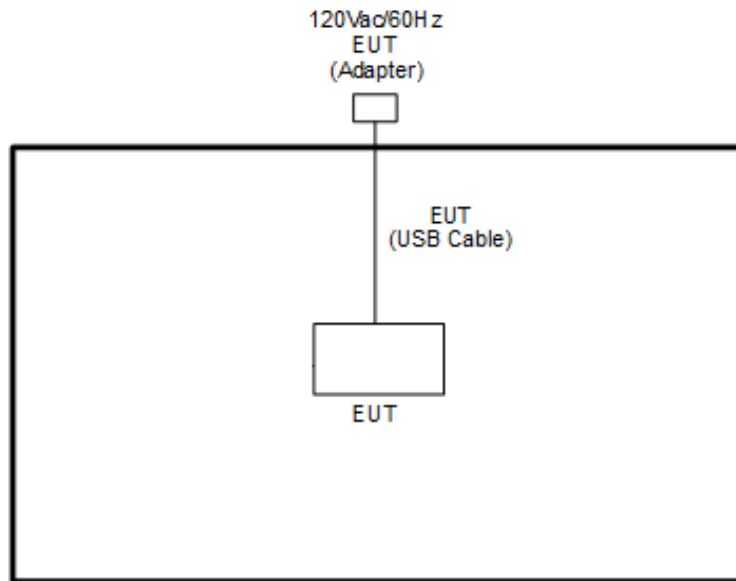

2.4 EUT Operation Test Setup

The RF test items, utility “QRCT v4.0.00067.0” was installed in Notebook which was programmed in order to make the EUT get into the engineering modes to provide channel selection, power level, data rate and the application type and for continuous transmitting signals.

3 Test Result

3.1 Output Power Measurement

3.1.1 Limit of Output Power

For systems using digital modulation in the 2400-2483.5MHz, the limit for output power is 30dBm. If transmitting antenna with directional gain greater than 6dBi is used, the peak output power from the intentional radiator shall be reduced below the above stated value by the amount in dB that the directional gain of the antenna exceeds 6 dBi. In case of point-to-point operation, the limit has to be reduced by 1dB for every 3dB that the directional gain of the antenna exceeds 6dBi.

3.1.2 Measuring Instruments

See list of measuring equipment of this test report.

3.1.3 Test Procedures

1. For Peak Power, the testing follows ANSI C63.10 Section 11.9.1.3 PKPM1
2. For Average Power, the testing follows ANSI C63.10 Section 11.9.2.3.2 Method AVGPM-G
3. The RF output of EUT was connected to the power meter by RF cable and attenuator. The path loss was compensated to the results for each measurement.
4. Set to the maximum power setting and enable the EUT transmit continuously.
5. Measure the conducted output power and record the results in the test report.

3.1.4 Test Setup

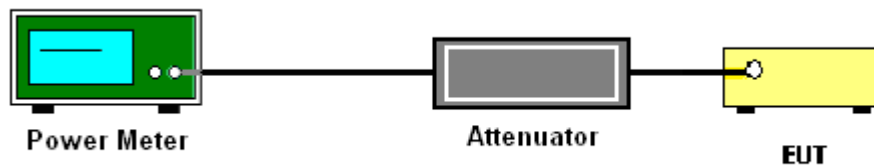



3.1.5 Test Result of Peak Output Power

Test Engineer :	Ryan Lin and Tommy Lee	Temperature :	21.2~24.1°C
		Relative Humidity :	47.2~57.8%

2.4GHz Band Single Antenna																
Mod.	Data Rate	NTX	CH.	Freq. (MHz)	Peak Conducted Power (dBm)			Conducted Power Limit (dBm)		DG (dBi)		EIRP Power (dBm)		EIRP Power Limit (dBm)		Pass /Fail
					Ant1	Ant2	SUM	Ant1	Ant2	Ant1	Ant2	Ant1	Ant2	Ant1	Ant2	
11b	1Mbps	1	1	2412	23.02	-		30.00	-	2.31	-	25.33	-	36.00	-	Pass
11b	1Mbps	1	6	2437	22.92	-		30.00	-	2.31	-	25.23	-	36.00	-	Pass
11b	1Mbps	1	11	2462	22.99	-		30.00	-	2.31	-	25.30	-	36.00	-	Pass
11g	6Mbps	1	1	2412	22.36	-		30.00	-	2.31	-	24.67	-	36.00	-	Pass
11g	6Mbps	1	6	2437	23.86	-		30.00	-	2.31	-	26.17	-	36.00	-	Pass
11g	6Mbps	1	11	2462	22.03	-		30.00	-	2.31	-	24.34	-	36.00	-	Pass
HT20	MCS0	1	1	2412	21.46	-		30.00	-	2.31	-	23.77	-	36.00	-	Pass
HT20	MCS0	1	6	2437	24.19	-		30.00	-	2.31	-	26.50	-	36.00	-	Pass
HT20	MCS0	1	11	2462	21.59	-		30.00	-	2.31	-	23.90	-	36.00	-	Pass
HT40	MCS0	1	3	2422	19.55	-		30.00	-	2.31	-	21.86	-	36.00	-	Pass
HT40	MCS0	1	6	2437	22.67	-		30.00	-	2.31	-	24.98	-	36.00	-	Pass
HT40	MCS0	1	9	2452	21.85	-		30.00	-	2.31	-	24.16	-	36.00	-	Pass
VHT20	MCS0	1	1	2412	21.45	-		30.00	-	2.31	-	23.76	-	36.00	-	Pass
VHT20	MCS0	1	6	2437	24.09	-		30.00	-	2.31	-	26.40	-	36.00	-	Pass
VHT20	MCS0	1	11	2462	21.58	-		30.00	-	2.31	-	23.89	-	36.00	-	Pass
VHT40	MCS0	1	3	2422	19.53	-		30.00	-	2.31	-	21.84	-	36.00	-	Pass
VHT40	MCS0	1	6	2437	22.65	-		30.00	-	2.31	-	24.96	-	36.00	-	Pass
VHT40	MCS0	1	9	2452	21.85	-		30.00	-	2.31	-	24.16	-	36.00	-	Pass



3.1.6 Test Result of Average Output Power (Reporting Only)

Test Engineer :	Ryan Lin and Tommy Lee	Temperature :	21.2~24.1℃
		Relative Humidity :	47.2~57.8%

2.4GHz Band Single Antenna											
Mod.	Data Rate	NTX	CH.	Freq. (MHz)	Average Conducted Power (dBm)			DG (dBi)		EIRP Power (dBm)	
					Ant1	Ant2	SUM	Ant1	Ant2	Ant1	Ant2
11b	1Mbps	1	1	2412	21.20	-	-	2.31	-	23.51	-
11b	1Mbps	1	6	2437	21.10	-	-	2.31	-	23.41	-
11b	1Mbps	1	11	2462	21.10	-	-	2.31	-	23.41	-
11g	6Mbps	1	1	2412	18.30	-	-	2.31	-	20.61	-
11g	6Mbps	1	6	2437	20.30	-	-	2.31	-	22.61	-
11g	6Mbps	1	11	2462	17.80	-	-	2.31	-	20.11	-
HT20	MCS0	1	1	2412	17.10	-	-	2.31	-	19.41	-
HT20	MCS0	1	6	2437	20.60	-	-	2.31	-	22.91	-
HT20	MCS0	1	11	2462	17.20	-	-	2.31	-	19.51	-
HT40	MCS0	1	3	2422	14.10	-	-	2.31	-	16.41	-
HT40	MCS0	1	6	2437	16.70	-	-	2.31	-	19.01	-
HT40	MCS0	1	9	2452	16.10	-	-	2.31	-	18.41	-
VHT20	MCS0	1	1	2412	17.00	-	-	2.31	-	19.31	-
VHT20	MCS0	1	6	2437	20.50	-	-	2.31	-	22.81	-
VHT20	MCS0	1	11	2462	17.10	-	-	2.31	-	19.41	-
VHT40	MCS0	1	3	2422	14.00	-	-	2.31	-	16.31	-
VHT40	MCS0	1	6	2437	16.60	-	-	2.31	-	18.91	-
VHT40	MCS0	1	9	2452	16.10	-	-	2.31	-	18.41	-



3.2 Radiated Band Edges and Spurious Emission Measurement

3.2.1 Limit of Radiated band edge and Spurious Emission Measurement

In any 100 kHz bandwidth outside the intentional radiator frequency band, all harmonics/spurious must be at least 20 dB below the highest emission level within the authorized band. If the output power of this device was measured by spectrum analyzer, the attenuation under this paragraph shall be 30 dB instead of 20 dB. In addition, radiated emissions which fall in the restricted bands must also comply with the limits as below.

Frequency (MHz)	Field Strength (microvolts/meter)	Measurement Distance (meters)
0.009 – 0.490	2400/F(kHz)	300
0.490 – 1.705	24000/F(kHz)	30
1.705 – 30.0	30	30
30 – 88	100	3
88 – 216	150	3
216 - 960	200	3
Above 960	500	3

3.2.2 Measuring Instruments

See list of measuring equipment of this test report.

**3.2.3 Test Procedures**

1. The testing follows the ANSI C63.10 Section 11.12.1 Radiated emission measurements.
2. The EUT was arranged to its worst case and then tune the antenna tower (from 1 m to 4 m) and turntable (from 0 degree to 360 degrees) to find the maximum reading. A pre-amp and a high pass filter are used for the test in order to get better signal level.
3. The EUT was placed on a turntable with 0.8 meter for frequency below 1GHz and 1.5 meter for frequency above 1GHz respectively above ground.
4. The EUT was set 3 meters from the interference receiving antenna, which was mounted on the top of a variable height antenna tower.
5. Corrected Reading: Antenna Factor + Cable Loss + Read Level - Preamp Factor = Level
6. For testing below 1GHz, if the emission level of the EUT in peak mode was 3 dB lower than the limit specified, then peak values of EUT will be reported, otherwise, the emissions will be repeated one by one using the CISPR quasi-peak method and reported.
7. For testing above 1GHz, the emission level of the EUT in peak mode was 20dB lower than average limit (that means the emission level in average mode also complies with the limit in average mode), then peak values of EUT will be reported, otherwise, the emissions will be measured in average mode again and reported.
8. Use the following spectrum analyzer settings:
 - (1) Span shall wide enough to fully capture the emission being measured;
 - (2) Set RBW=100 kHz for $f < 1$ GHz; $VBW \geq RBW$; Sweep = auto; Detector function = peak; Trace = max hold;
 - (3) Set RBW = 1 MHz, VBW= 3MHz for $f \geq 1$ GHz for peak measurement.
For average measurement:
 - $VBW = 10$ Hz, when duty cycle is no less than 98 percent.
 - $VBW \geq 1/T$, when duty cycle is less than 98 percent where T is the minimum transmission duration over which the transmitter is on and is transmitting at its maximum power control level for the tested mode of operation.

3.2.4 Test Setup

For radiated emissions below 30MHz

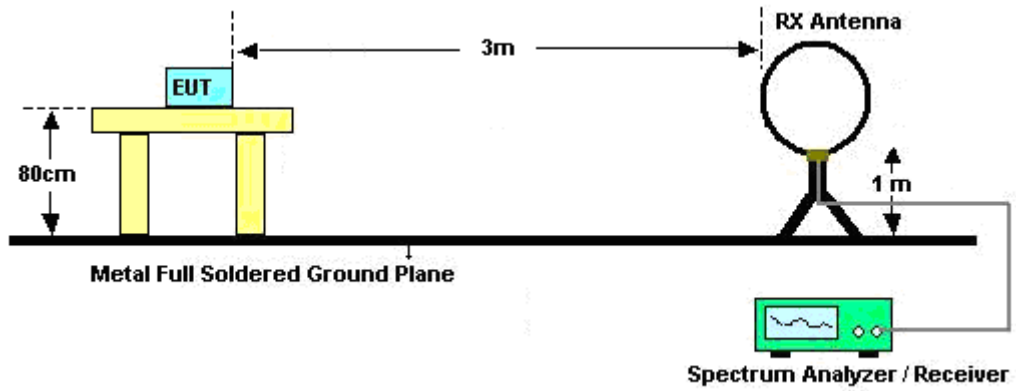

For radiated emissions from 30MHz to 1GHz

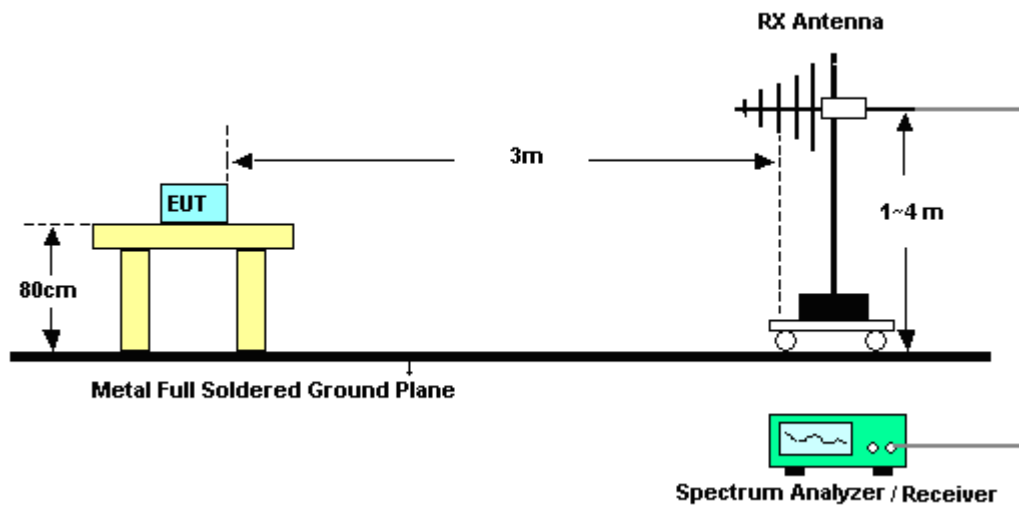

For radiated emissions above 1GHz

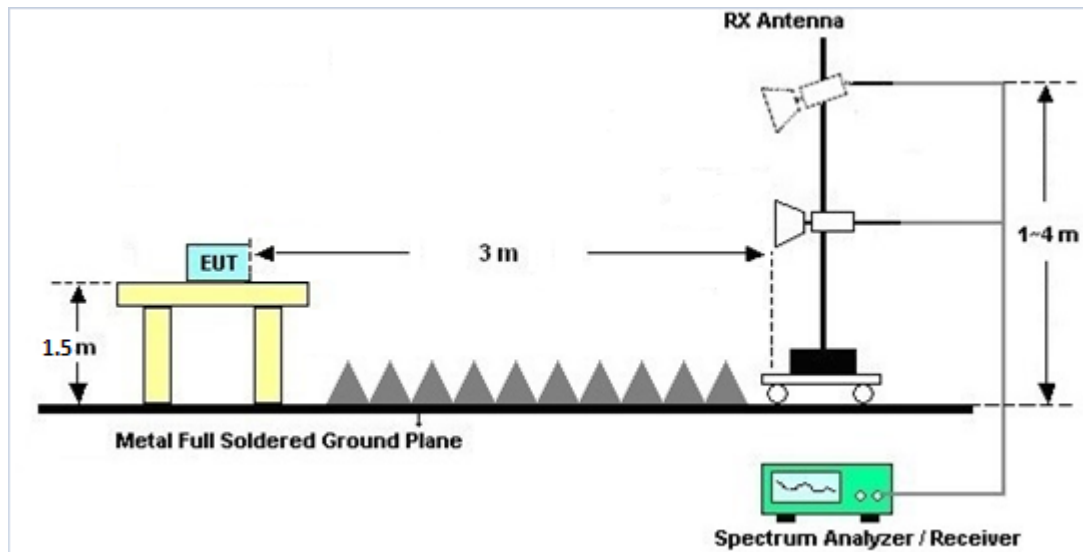

3.2.5 Test Results of Radiated Spurious Emissions (9kHz ~ 30MHz)

The low frequency, which started from 9 kHz to 30MHz, was pre-scanned and the result which was 20dB lower than the limit line was not reported.

There is a comparison data of both open-field test site and alternative test site - semi-Anechoic chamber according to 414788 D01 Radiated Test Site v01r01, and the result came out very similar.

3.2.6 Test Result of Radiated Spurious at Band Edges

Please refer to Appendix A and B.

3.2.7 Duty Cycle

Please refer to Appendix C.

3.2.8 Test Result of Radiated Spurious Emission (30MHz ~ 10th Harmonic)

Please refer to Appendix A and B.



3.3 Antenna Requirements

3.3.1 Standard Applicable

If directional gain of transmitting Antennas is greater than 6dBi, the power shall be reduced by the same level in dB comparing to gain minus 6dBi. The use of a permanently attached Antenna or of an Antenna that uses a unique coupling to the intentional radiator shall be considered sufficient to comply with the rule.

3.3.2 Antenna Anti-Replacement Construction

An embedded-in antenna design is used.

3.3.3 Antenna Gain

The antenna peak gain of EUT is less than 6 dBi. Therefore, it is not necessary to reduce maximum peak output power limit.



4 List of Measuring Equipment

Instrument	Brand Name	Model No.	Serial No.	Characteristics	Calibration Date	Test Date	Due Date	Remark
Hygrometer	Testo	608-H1	34893241	N/A	Mar. 02, 2020	Aug. 04, 2020~ Aug. 31, 2020	Mar. 01, 2021	Conducted (TH05-HY)
Power Sensor	DARE	RPR3006W	16I00054S NO10	10MHz~6GHz	Dec. 23, 2019	Aug. 04, 2020~ Aug. 31, 2020	Dec. 22, 2020	Conducted (TH05-HY)
Signal Analyzer	Rohde & Schwarz	FSV40	101397	10Hz~40GHz	Nov. 15, 2019	Aug. 04, 2020~ Aug. 31, 2020	Nov. 14, 2020	Conducted (TH05-HY)
Switch Box & RF Cable	EM Electronics	EMSW18SE	SW200302	N/A	Mar. 17, 2020	Aug. 04, 2020~ Aug. 31, 2020	Mar. 16, 2021	Conducted (TH05-HY)
Loop Antenna	Rohde & Schwarz	HFH2-Z2	100315	9 kHz~30 MHz	Dec. 26, 2019	Sep. 22, 2020~ Sep. 29, 2020	Dec. 25, 2020	Radiation (03CH07-HY)
Bilog Antenna	TESEQ	CBL 6111D & 00800N1D01 N-06	35419 & 03	30MHz~1GHz	Apr. 29, 2020	Sep. 22, 2020~ Sep. 29, 2020	Apr. 28, 2021	Radiation (03CH07-HY)
Double Ridge Horn Antenna	ESCO	3117	00075962	1GHz ~ 18GHz	Dec. 06, 2019	Sep. 22, 2020~ Sep. 29, 2020	Dec. 05, 2020	Radiation (03CH07-HY)
SHF-EHF Horn Antenna	SCHWARZBECK	BBHA 9170	BBHA9170 584	18GHz~40GHz	Dec. 10, 2019	Sep. 22, 2020~ Sep. 29, 2020	Dec. 09, 2020	Radiation (03CH07-HY)
EMI Test Receiver	Agilent	N9038A(MX E)	MY5329005 3	20Hz~26.5GHz	May 21, 2020	Sep. 22, 2020~ Sep. 29, 2020	May 20, 2021	Radiation (03CH07-HY)
Spectrum Analyzer	Agilent	N9030A	MY5235027 6	3Hz~44GHz	Jun. 09, 2020	Sep. 22, 2020~ Sep. 29, 2020	Jun. 08, 2021	Radiation (03CH07-HY)
Preamplifier	COM-POWER	PA-103A	161241	10MHz~1GHz	May 19, 2020	Sep. 22, 2020~ Sep. 29, 2020	May 18, 2021	Radiation (03CH07-HY)
Preamplifier	MITEQ	AMF-7D-001 01800-30-10 P	1590075	1GHz~18GHz	Apr. 23, 2020	Sep. 22, 2020~ Sep. 29, 2020	Apr. 22, 2021	Radiation (03CH07-HY)
Preamplifier	Agilent	8449B	3008A0236 2	1GHz~26.5GHz	Nov. 01, 2019	Sep. 22, 2020~ Sep. 29, 2020	Oct. 31, 2020	Radiation (03CH07-HY)
Preamplifier	EMEC	EM18G40G	060715	18GHz~40GHz	Dec. 13, 2019	Sep. 22, 2020~ Sep. 29, 2020	Dec. 12, 2020	Radiation (03CH07-HY)
RF Cable	HUBER + SUHNER	SUCOFLEX 102	MY2858/2,8 01606/2	18GHz~40GHz	Feb. 25, 2020	Sep. 22, 2020~ Sep. 29, 2020	Feb. 24, 2021	Radiation (03CH07-HY)
RF Cable	HUBER + SUHNER	SUCOFLEX 104	MY24971/4, MY28655/4	9kHz~30MHz	Feb. 25, 2020	Sep. 22, 2020~ Sep. 29, 2020	Feb. 24, 2021	Radiation (03CH07-HY)
RF Cable	HUBER + SUHNER	SUCOFLEX 104	MY28655/4, MY24971/4, MY15682/4	30MHz~1GHz	Feb. 25, 2020	Sep. 22, 2020~ Sep. 29, 2020	Feb. 24, 2021	Radiation (03CH07-HY)
RF Cable	HUBER + SUHNER	SUCOFLEX 104	MY28655/4, MY24971/4, MY15682/4	1GHz~18GHz	Feb. 25, 2020	Sep. 22, 2020~ Sep. 29, 2020	Feb. 24, 2021	Radiation (03CH07-HY)
Antenna Mast	Max-Full	MFA520BS	N/A	1m~4m	N/A	Sep. 22, 2020~ Sep. 29, 2020	N/A	Radiation (03CH07-HY)
Turn Table	ChainTek	Chaintek 3000	N/A	0~360 Degree	N/A	Sep. 22, 2020~ Sep. 29, 2020	N/A	Radiation (03CH07-HY)
USB Data Logger	TECPEL	TR-32	HE17XB24 95	N/A	N/A	Sep. 22, 2020~ Sep. 29, 2020	N/A	Radiation (03CH07-HY)
Software	Audix	E3 6.2009-8-24	N/A	N/A	N/A	Sep. 22, 2020~ Sep. 29, 2020	N/A	Radiation (03CH07-HY)



5 Uncertainty of Evaluation

Uncertainty of Radiated Emission Measurement (30 MHz ~ 1000 MHz)

Measuring Uncertainty for a Level of Confidence of 95% ($U = 2Uc(y)$)	4.7
---	-----

Uncertainty of Radiated Emission Measurement (1000 MHz ~ 18000 MHz)

Measuring Uncertainty for a Level of Confidence of 95% ($U = 2Uc(y)$)	5.3
---	-----

Uncertainty of Radiated Emission Measurement (18000 MHz ~ 40000 MHz)

Measuring Uncertainty for a Level of Confidence of 95% ($U = 2Uc(y)$)	5.0
---	-----



Appendix A. Radiated Spurious Emission

Test Engineer :	Jesse Wang, Stan Hsieh and Ken Wu	Temperature :	22~23°C
		Relative Humidity :	51~58%

2.4GHz 2400~2483.5MHz

WIFI 802.11b (Band Edge @ 3m)

WIFI	Note	Frequency	Level	Over	Limit	Read	Antenna	Path	Preamp	Ant	Table	Peak	Pol.
Ant.				Limit	Line	Level	Factor	Loss	Factor	Pos	Pos	Avg.	
1		(MHz)	(dBμV/m)	(dB)	(dBμV/m)	(dBμV)	(dB/m)	(dB)	(dB)	(cm)	(deg)	(P/A)	(H/V)
802.11b CH 11 2462MHz	*	2462	110.38	-	-	95.54	32.03	18.09	35.28	124	83	P	H
	*	2462	107.09	-	-	92.25	32.03	18.09	35.28	124	83	A	H
		2483.96	54.6	-19.4	74	39.7	32.07	18.12	35.29	124	83	P	H
		2483.52	46.84	-7.16	54	31.94	32.07	18.12	35.29	124	83	A	H
													H
													H
	*	2462	104.89	-	-	90.05	32.03	18.09	35.28	162	0	P	V
	*	2462	101.64	-	-	86.8	32.03	18.09	35.28	162	0	A	V
		2497.4	53.7	-20.3	74	38.76	32.1	18.12	35.3	162	0	P	V
		2483.52	43.71	-10.29	54	28.81	32.07	18.12	35.29	162	0	A	V
													V
													V
Remark	1. No other spurious found. 2. All results are PASS against Peak and Average limit line.												



**2.4GHz 2400~2483.5MHz
WIFI 802.11b (Harmonic @ 3m)**

WIFI Ant. 1	Note	Frequency (MHz)	Level (dBμV/m)	Over Limit (dB)	Limit Line (dBμV/m)	Read Level (dBμV)	Antenna Factor (dB/m)	Path Loss (dB)	Preamp Factor (dB)	Ant Pos (cm)	Table Pos (deg)	Peak Avg. (P/A)	Pol. (H/V)
802.11b CH 11 2462MHz		4924	40.71	-33.29	74	52.99	34.23	12.13	58.64	100	0	P	H
		7386	45.63	-28.37	74	52.93	35.6	14.64	57.54	100	0	P	H
													H
													H
		4924	40.52	-33.48	74	52.8	34.23	12.13	58.64	100	0	P	V
		7386	47.58	-26.42	74	54.88	35.6	14.64	57.54	100	0	P	V
													V
													V
Remark	1. No other spurious found. 2. All results are PASS against Peak and Average limit line.												



**2.4GHz 2400~2483.5MHz
WIFI 802.11g (Band Edge @ 3m)**

WIFI Ant. 1	Note	Frequency (MHz)	Level (dBμV/m)	Over Limit (dB)	Limit Line (dBμV/m)	Read Level (dBμV)	Antenna Factor (dB/m)	Path Loss (dB)	Preamp Factor (dB)	Ant Pos (cm)	Table Pos (deg)	Peak Avg. (P/A)	Pol. (H/V)	
802.11g CH 11 2462MHz	*	2462	108.73	-	-	93.89	32.03	18.09	35.28	107	83	P	H	
	*	2462	100.96	-	-	86.12	32.03	18.09	35.28	107	83	A	H	
		2484.24	58.91	-15.09	74	44.01	32.07	18.12	35.29	107	83	P	H	
		2483.52	47.87	-6.13	54	32.97	32.07	18.12	35.29	107	83	A	H	
													H	
														H
	*	2462	103.48	-	-	88.64	32.03	8.09	35.28	162	0	P	V	
	*	2462	95.6	-	-	80.76	32.03	8.09	35.28	162	0	A	V	
		2483.88	53.77	-20.23	74	38.87	32.07	8.12	35.29	162	0	P	V	
		2483.52	43.81	-10.19	54	28.91	32.07	8.12	35.29	162	0	A	V	
														V
														V
Remark	1. No other spurious found. 2. All results are PASS against Peak and Average limit line.													



**2.4GHz 2400~2483.5MHz
WIFI 802.11g (Harmonic @ 3m)**

WIFI Ant. 1	Note	Frequency (MHz)	Level (dBμV/m)	Over Limit (dB)	Limit Line (dBμV/m)	Read Level (dBμV)	Antenna Factor (dB/m)	Path Loss (dB)	Preamp Factor (dB)	Ant Pos (cm)	Table Pos (deg)	Peak Avg. (P/A)	Pol. (H/V)	
802.11g CH 11 2462MHz		4924	41.94	-32.06	74	54.22	34.23	12.13	58.64	100	0	P	H	
		7386	41.29	-32.71	74	48.59	35.6	14.64	57.54	100	0	P	H	
													H	
													H	
			4924	40.15	-33.85	74	52.43	34.23	12.94	58.64	100	0	P	V
			7386	41.71	-32.29	74	49.01	35.6	15.52	57.54	100	0	P	V
														V
														V
Remark	1. No other spurious found. 2. All results are PASS against Peak and Average limit line.													



2.4GHz 2400~2483.5MHz
WIFI 802.11ac VHT40 (Band Edge @ 3m)

Table with 14 columns: WIFI Ant. 1, Note, Frequency (MHz), Level (dBµV/m), Over Limit (dB), Limit Line (dBµV/m), Read Level (dBµV), Antenna Factor (dB/m), Path Loss (dB), Preamp Factor (dB), Ant Pos (cm), Table Pos (deg), Peak Avg. (P/A), Pol. (H/V). Rows include test results for 802.11ac VHT40 CH 09 2452MHz and a Remark section.



**2.4GHz 2400~2483.5MHz
WIFI 802.11ac VHT40 (Harmonic @ 3m)**

WIFI Ant. 1	Note	Frequency (MHz)	Level (dBμV/m)	Over Limit (dB)	Limit Line (dBμV/m)	Read Level (dBμV)	Antenna Factor (dB/m)	Path Loss (dB)	Preamp Factor (dB)	Ant Pos (cm)	Table Pos (deg)	Peak Avg. (P/A)	Pol. (H/V)	
802.11ac VHT40 CH 09 2452MHz		4904	39.91	-34.09	74	52.32	34.17	12.11	58.69	100	0	P	H	
		7356	41.11	-32.89	74	48.51	35.5	14.61	57.51	100	0	P	H	
													H	
													H	
			4904	40.44	-33.56	74	52.85	34.17	12.11	58.69	100	0	P	V
			7356	40.29	-33.71	74	47.69	35.5	14.61	57.51	100	0	P	V
														V
														V
Remark	1. No other spurious found. 2. All results are PASS against Peak and Average limit line.													



Emission below 1GHz

2.4GHz WIFI 802.11ac VHT40 (LF)

WIFI	Note	Frequency	Level	Over	Limit	Read	Antenna	Path	Preamp	Ant	Table	Peak	Pol.	
Ant.		(MHz)	(dB μ V/m)	(dB)	(dB μ V/m)	(dB μ V)	(dB/m)	(dB)	(dB)	(cm)	(deg)	(P/A)	(H/V)	
2.4GHz 802.11ac VHT40 LF		31.62	21.98	-18.02	40	27.47	23.57	0.95	30.01	-	-	P	H	
		125.31	29.43	-14.07	43.5	40.05	17.46	1.88	29.96	-	-	P	H	
		149.61	25.58	-17.92	43.5	36.33	17.15	2.05	29.95	-	-	P	H	
		738.9	30.3	-15.7	46	27.74	27.54	4.61	29.59	-	-	P	H	
		851.6	32.21	-13.79	46	27.69	28.76	4.97	29.21	-	-	P	H	
		954.5	33.04	-12.96	46	25.96	30.48	5.27	28.67	100	0	P	H	
													H	
													H	
													H	
													H	
													H	
													H	
													H	
			30	31.54	-8.46	40	36.3	24.32	0.93	30.01	100	0	P	V
			39.99	26.74	-13.26	40	36.27	19.4	1.07	30	-	-	P	V
			61.86	24.99	-15.01	40	41.93	11.73	1.32	29.99	-	-	P	V
			783	30.05	-15.95	46	26.95	27.81	4.78	29.49	-	-	P	V
			875.4	32.1	-13.9	46	27.32	28.84	5.04	29.1	-	-	P	V
		953.8	33.86	-12.14	46	26.85	30.42	5.27	28.68	-	-	P	V	
												V		
												V		
												V		
												V		
												V		
												V		
Remark	1. No other spurious found. 2. All results are PASS against limit line.													



Note symbol

*	Fundamental Frequency which can be ignored. However, the level of any unwanted emissions shall not exceed the level of the fundamental frequency.
!	Test result is over limit line.
P/A	Peak or Average
H/V	Horizontal or Vertical



A calculation example for radiated spurious emission is shown as below:

WIFI	Note	Frequency	Level	Over	Limit	Read	Antenna	Path	Preamp	Ant	Table	Peak	Pol.
Ant.				Limit	Line	Level	Factor	Loss	Factor	Pos	Pos	Avg.	
1		(MHz)	(dBμV/m)	(dB)	(dBμV/m)	(dBμV)	(dB/m)	(dB)	(dB)	(cm)	(deg)	(P/A)	(H/V)
802.11b		2390	55.45	-18.55	74	54.51	32.22	4.58	35.86	103	308	P	H
CH 01													
2412MHz		2390	43.54	-10.46	54	42.6	32.22	4.58	35.86	103	308	A	H

1. Path Loss(dB) = Cable loss(dB) + Filter loss(dB) + Attenuator loss(dB)
2. Level(dBμV/m) =
Antenna Factor(dB/m) + Path Loss(dB) + Read Level(dBμV) - Preamp Factor(dB)
3. Over Limit(dB) = Level(dBμV/m) – Limit Line(dBμV/m)

For Peak Limit @ 2390MHz:

1. Level(dBμV/m)
= Antenna Factor(dB/m) + Path Loss(dB) + Read Level(dBμV) - Preamp Factor(dB)
= 32.22(dB/m) + 4.58(dB) + 54.51(dBμV) – 35.86 (dB)
= 55.45 (dBμV/m)
2. Over Limit(dB)
= Level(dBμV/m) – Limit Line(dBμV/m)
= 55.45(dBμV/m) – 74(dBμV/m)
= -18.55(dB)

For Average Limit @ 2390MHz:

1. Level(dBμV/m)
= Antenna Factor(dB/m) + Path Loss(dB) + Read Level(dBμV) - Preamp Factor(dB)
= 32.22(dB/m) + 4.58(dB) + 42.6(dBμV) – 35.86 (dB)
= 43.54 (dBμV/m)
2. Over Limit(dB)
= Level(dBμV/m) – Limit Line(dBμV/m)
= 43.54(dBμV/m) – 54(dBμV/m)
= -10.46(dB)

Both peak and average measured complies with the limit line, so test result is "PASS".



Appendix B. Radiated Spurious Emission Plots

Test Engineer :	Jesse Wang, Stan Hsieh and Ken Wu	Temperature :	22~23°C
		Relative Humidity :	51~58%

Note symbol

-L	Low channel location
-R	High channel location



2.4GHz 2400~2483.5MHz
WIFI 802.11b (Band Edge @ 3m)

WIFI ANT	2.4GHz 2400~2483.5MHz Band Edge @ 3m	
1	802.11b CH11 2462MHz	
	Horizontal	Fundamental
Peak	<p>Site : 03CH07-HY Condition : PEAK_BE_74 3m HF ANT_00075962 HORIZONTAL : RBW:1000.000kHz VBW:3000.000kHz SWT:Auto Detector : Peak Project : 052913-03 Mode : 12</p>	<p>Site : 03CH07-HY Condition : PEAK_74 3m HF ANT_00075962 HORIZONTAL : RBW:1000.000kHz VBW:3000.000kHz SWT:Auto Detector : Peak Project : 052913-03 Mode : 12</p>
Avg.	<p>Site : 03CH07-HY Condition : AVG_BE_54 3m HF ANT_00075962 HORIZONTAL : RBW:1000.000kHz VBW:0.0100kHz SWT:Auto Detector : Peak Project : 052913-03 Mode : 12</p>	<p>Site : 03CH07-HY Condition : AVG_54 3m HF ANT_00075962 HORIZONTAL : RBW:1000.000kHz VBW:0.0100kHz SWT:Auto Detector : Peak Project : 052913-03 Mode : 12</p>

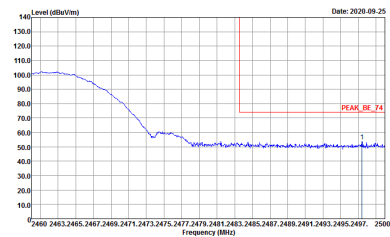
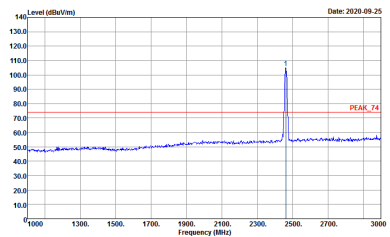
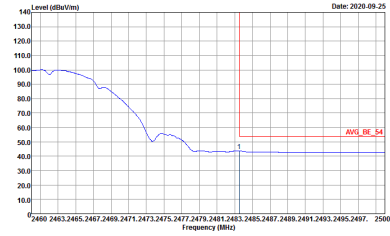
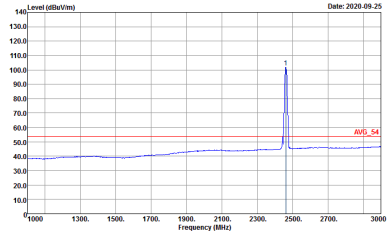

WIFI	2.4GHz 2400~2483.5MHz Band Edge @ 3m	
ANT	802.11b CH11 2462MHz	
1	Vertical	Fundamental
Peak	 <p>Date: 2020-09-25</p> <p>Site : 03CH07-HY Condition : PEAK_BE_74 3m HF_ANT_00075962 VERTICAL RBW:1000.000kHz VBW:3000.000kHz SWT:Auto Detector : Peak Project : 052913-03 Mode : 12</p>	 <p>Date: 2020-09-25</p> <p>Site : 03CH07-HY Condition : PEAK_74 3m HF_ANT_00075962 VERTICAL RBW:1000.000kHz VBW:3000.000kHz SWT:Auto Detector : Peak Project : 052913-03 Mode : 12</p>
Avg.	 <p>Date: 2020-09-25</p> <p>Site : 03CH07-HY Condition : AVG_BE_54 3m HF_ANT_00075962 VERTICAL RBW:1000.000kHz VBW:0.010kHz SWT:Auto Detector : Peak Project : 052913-03 Mode : 12</p>	 <p>Date: 2020-09-25</p> <p>Site : 03CH07-HY Condition : AVG_54 3m HF_ANT_00075962 VERTICAL RBW:1000.000kHz VBW:0.010kHz SWT:Auto Detector : Peak Project : 052913-03 Mode : 12</p>

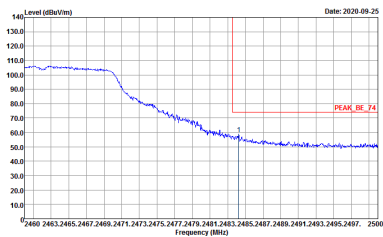
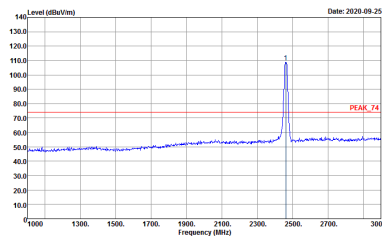
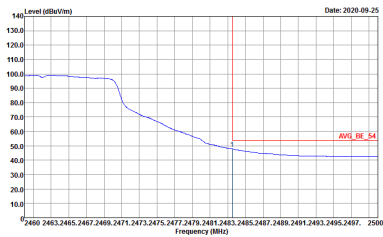
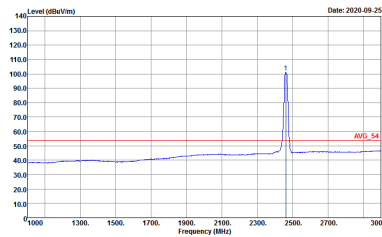

2.4GHz 2400~2483.5MHz
WIFI 802.11g (Band Edge @ 3m)

WIFI ANT	2.4GHz 2400~2483.5MHz Band Edge @ 3m 802.11g CH11 2462MHz	
1	Horizontal	Fundamental
Peak	 <p>Site : 03CH07-HY Condition : PEAK_BE_74 3m HF ANT_00075962 HORIZONTAL : RBW:1000.000kHz VBW:3000.000kHz SWT:Auto Detector : Peak Project : 052913-03 Mode : 15</p>	 <p>Site : 03CH07-HY Condition : PEAK_74 3m HF ANT_00075962 HORIZONTAL : RBW:1000.000kHz VBW:3000.000kHz SWT:Auto Detector : Peak Project : 052913-03 Mode : 15</p>
Avg.	 <p>Site : 03CH07-HY Condition : AVG_BE_54 3m HF ANT_00075962 HORIZONTAL : RBW:1000.000kHz VBW:0.0100kHz SWT:Auto Detector : Peak Project : 052913-03 Mode : 15</p>	 <p>Site : 03CH07-HY Condition : AVG_54 3m HF ANT_00075962 HORIZONTAL : RBW:1000.000kHz VBW:0.0100kHz SWT:Auto Detector : Peak Project : 052913-03 Mode : 15</p>

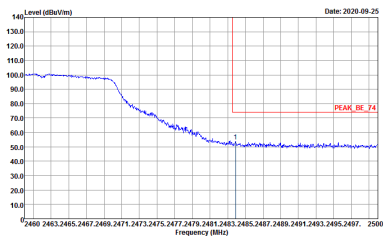
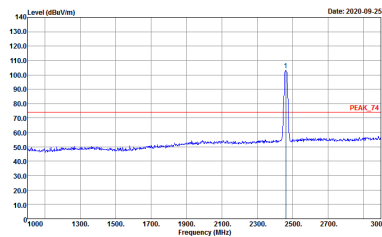
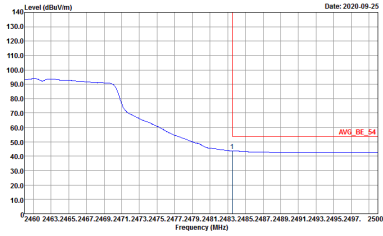
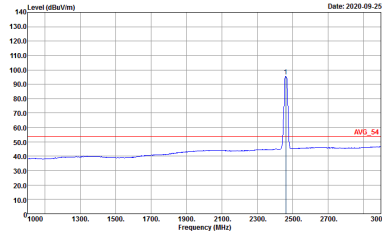

WIFI	2.4GHz 2400~2483.5MHz Band Edge @ 3m	
ANT	802.11g CH11 2462MHz	
1	Vertical	Fundamental
Peak	 <p>Site : 03CH07-HY Condition : PEAK_BE_74 3m HF_ANT_00075962 VERTICAL RBW:1000.000kHz VBW:3000.000kHz SWT:Auto Detector : Peak Project : 052913-03 Mode : 15</p>	 <p>Site : 03CH07-HY Condition : PEAK_74 3m HF_ANT_00075962 VERTICAL RBW:1000.000kHz VBW:3000.000kHz SWT:Auto Detector : Peak Project : 052913-03 Mode : 15</p>
Avg.	 <p>Site : 03CH07-HY Condition : AVG_BE_54 3m HF_ANT_00075962 VERTICAL RBW:1000.000kHz VBW:0.0100MHz SWT:Auto Detector : Peak Project : 052913-03 Mode : 15</p>	 <p>Site : 03CH07-HY Condition : AVG_54 3m HF_ANT_00075962 VERTICAL RBW:1000.000kHz VBW:0.0100MHz SWT:Auto Detector : Peak Project : 052913-03 Mode : 15</p>



2.4GHz 2400~2483.5MHz

WIFI 802.11ac VHT40 (Band Edge @ 3m)

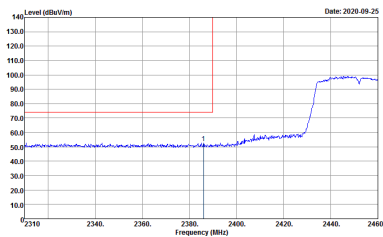
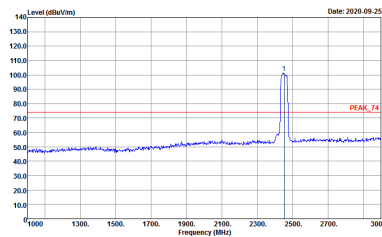
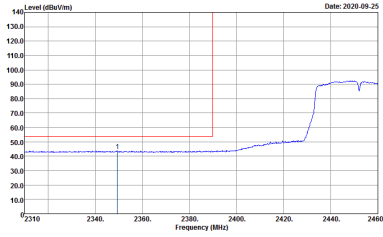
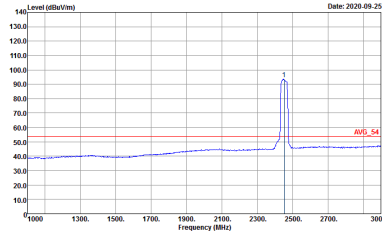
WIFI ANT	2.4GHz 2400~2483.5MHz Band Edge @ 3m 802.11ac VH40 CH09 2452MHz - L	
1	Horizontal	Fundamental
Peak	 <p>Site : 03CH07-HY Condition : PEAK_BE_74 3m HF ANT_00075962 HORIZONTAL Detector : Peak Project : 052913-03 Mode : 21</p>	 <p>Site : 03CH07-HY Condition : PEAK_74 3m HF ANT_00075962 HORIZONTAL Detector : Peak Project : 052913-03 Mode : 21</p>
Avg.	 <p>Site : 03CH07-HY Condition : AVG_BE_54 3m HF ANT_00075962 HORIZONTAL Detector : Peak Project : 052913-03 Mode : 21</p>	 <p>Site : 03CH07-HY Condition : AVG_54 3m HF ANT_00075962 HORIZONTAL Detector : Peak Project : 052913-03 Mode : 21</p>



WIFI	2.4GHz 2400~2483.5MHz Band Edge @ 3m	
ANT	802.11ac VH40 CH09 2452MHz - R	
1	Horizontal	Fundamental
Peak	<p>Site : 03CH07-01 Condition : PEAK_BE_74 3m HF_ANT_00075962 HORIZONTAL Detector : Peak Project : 052913-03 Mode : Z1</p>	Left blank
Avg.	<p>Site : 03CH07-01 Condition : AVG_BE_54 3m HF_ANT_00075962 HORIZONTAL Detector : Peak Project : 052913-03 Mode : Z1</p>	Left blank



WIFI	2.4GHz 2400~2483.5MHz Band Edge @ 3m	
ANT	802.11ac VH40 CH09 2452MHz - L	
1	Vertical	Fundamental
Peak	<p>Site : 03CH07-HY Condition : PEAK_BE_74 3m HF_ANT_00075962 VERTICAL Detector : Peak Project : 052913-03 Mode : 21</p>	<p>Site : 03CH07-HY Condition : PEAK_74 3m HF_ANT_00075962 VERTICAL Detector : Peak Project : 052913-03 Mode : 21</p>
Avg.	<p>Site : 03CH07-HY Condition : AVG_BE_34 3m HF_ANT_00075962 VERTICAL Detector : Peak Project : 052913-03 Mode : 21</p>	<p>Site : 03CH07-HY Condition : AVG_34 3m HF_ANT_00075962 VERTICAL Detector : Peak Project : 052913-03 Mode : 21</p>

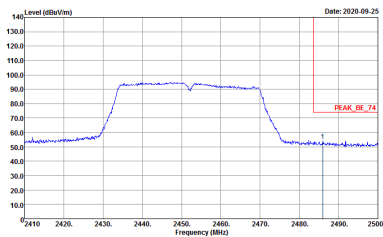
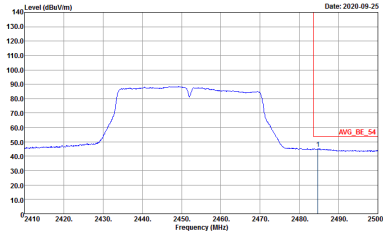

WIFI	2.4GHz 2400~2483.5MHz Band Edge @ 3m	
ANT	802.11ac VH40 CH09 2452MHz - R	
1	Vertical	Fundamental
<p>Peak</p>	 <p>Site : 03CH07-01 Condition : PEAK_BE_74 3m HF_ANT_00075962 VERTICAL Detector : Peak Project : 052913-03 Mode : Z1</p>	<p>Left blank</p>
<p>Avg.</p>	 <p>Site : 03CH07-01 Condition : AVG_BE_54 3m HF_ANT_00075962 VERTICAL Detector : Peak Project : 052913-03 Mode : Z1</p>	<p>Left blank</p>



2.4GHz 2400~2483.5MHz
WIFI 802.11b (Harmonic @ 3m)

WIFI ANT	2.4GHz 2400~2483.5MHz Harmonic @ 3m	
1	Horizontal	Vertical
Peak Avg.	<p>Site : 09CH07-4H Condition : PEAK_24.3m HF_ANT_00075962 HORIZONTAL Detector : Peak Project : 052913-03 Mode : 12</p>	<p>Site : 09CH07-4H Condition : PEAK_24.3m HF_ANT_00075962 VERTICAL Detector : Peak Project : 052913-03 Mode : 12</p>



2.4GHz 2400~2483.5MHz
WIFI 802.11g (Harmonic @ 3m)

WIFI ANT	2.4GHz 2400~2483.5MHz Harmonic @ 3m	
1	Horizontal	Vertical
Peak Avg.	<p>Site : 03CH07-4H Condition : PEAK_24.3m HF_ANT_00075962 HORIZONTAL Detector : Peak Project : 052913-03 Mode : 15</p>	<p>Site : 03CH07-4H Condition : PEAK_24.3m HF_ANT_00075962 VERTICAL Detector : Peak Project : 052913-03 Mode : 15</p>

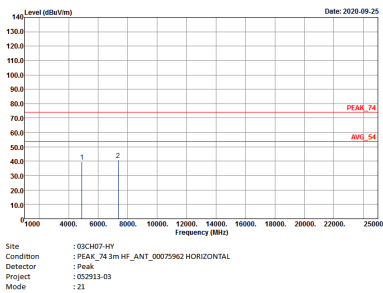
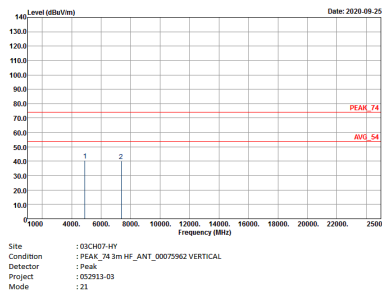

2.4GHz 2400~2483.5MHz
WIFI 802.11ac VHT40 (Harmonic @ 3m)

WIFI ANT	2.4GHz 2400~2483.5MHz Harmonic @ 3m 802.11ac VHT40 CH09 2452MHz	
1	Horizontal	Vertical
<p>Peak</p> <p>Avg.</p>	 <p>Site : 03CH07-4H Condition : PEAK_24.3m HF_ANT_00075962 HORIZONTAL Detector : Peak Project : 052913-03 Mode : 21</p>	 <p>Site : 03CH07-4H Condition : PEAK_24.3m HF_ANT_00075962 VERTICAL Detector : Peak Project : 052913-03 Mode : 21</p>

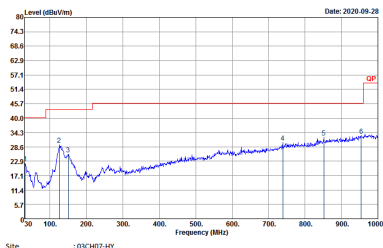
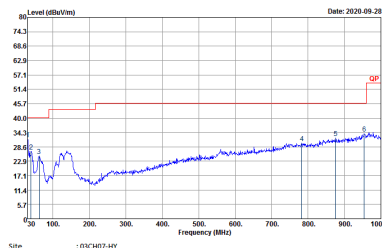

Emission below 1GHz
2.4GHz WIFI 802.11ac VHT40 (LF)

WIFI ANT	2.4GHz 2400~2483.5MHz 802.11ac VHT40 LF	
1	Horizontal	Vertical
QP / Peak	 <p>Site : 03CH07-HY Condition : QP 3m LF-ANT:15419(6) HORIZONTAL Detector : Peak Project : 052913-03 Mode : 24</p>	 <p>Site : 03CH07-HY Condition : QP 3m LF-ANT:15419(6) VERTICAL Detector : Peak Project : 052913-03 Mode : 24</p>



Appendix C. Duty Cycle Plots

Band	Duty Cycle(%)	T(us)	1/T(kHz)	VBW Setting	Duty Factor(dB)
802.11b	99.04	12440	0.08	10Hz	0.04
802.11g	98.10	2060	0.49	10Hz	0.08
2.4GHz 802.11ac VHT40	94.00	940	1.06	3kHz	0.27

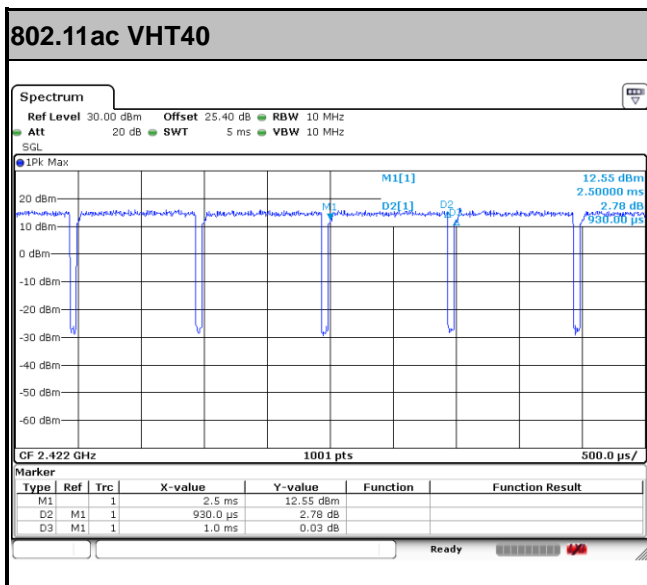
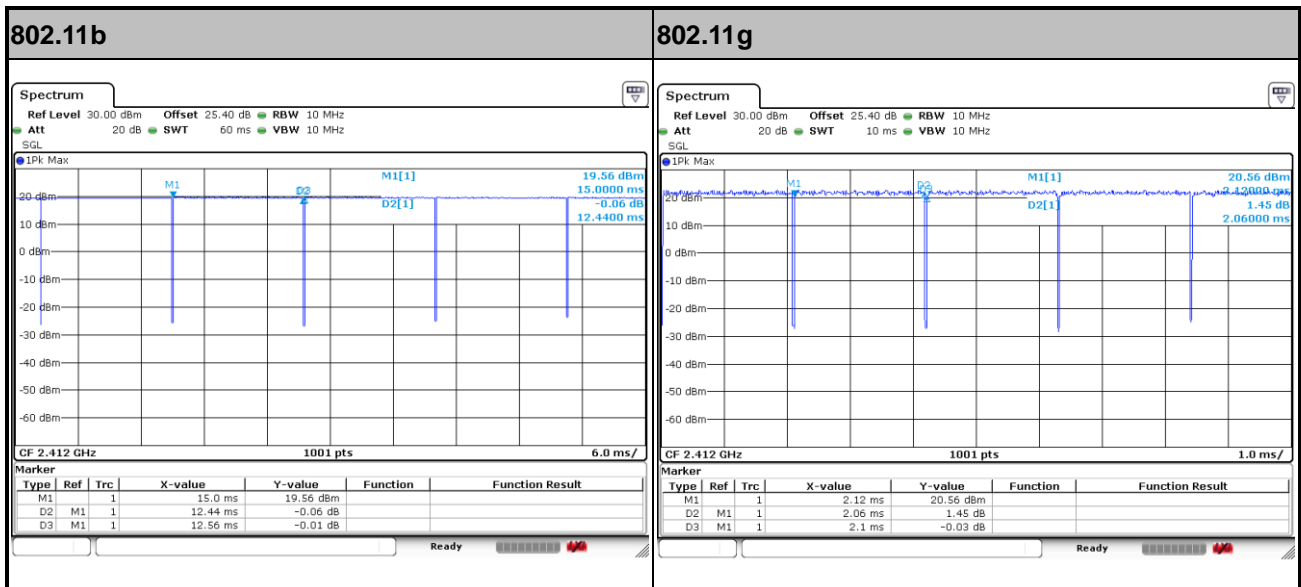



Appendix E. Original Report

Please refer to Sporton report number FR052917-01C as below.