



# SPORTON International Inc.

No. 52, Hwa Ya 1st Rd., Kwei-Shan Hsiang, TaoYuan Hsien, Taiwan, R.O.C.  
Ph: 886-3-327-3456 / FAX: 886-3-327-0973 / www.sporton.com.tw

## FCC RADIO TEST REPORT

Applicant's company	Motorola, Inc.
Applicant Address	One Motorola Plaza Holtsville NY 111742 USA
FCC ID	UZ7MB82
Manufacturer's company	Wistron NeWeb Corporation
Manufacturer Address	20 Park Avenue II, Hsinchu Science Park, Hsinchu 308,Taiwan,R.O.C.

Product Name	MB82 Access Point Radio Module
Brand Name	Motorola
Model Name	AP-650(MB82)
Test Rule Part(s)	47 CFR FCC Part 15 Subpart E § 15.407
Test Freq. Range	5250 ~ 5350MHz / 5470 ~ 5725MHz
Received Date	Aug. 07, 2009
Final Test Date	Oct. 09, 2009
Submission Type	Class II Change
Operating Mode	Master

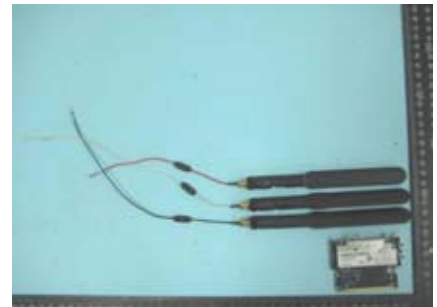

### Statement

Test result included is for the 802.11n and 802.11a (5250 ~ 5350MHz / 5470 ~ 5725MHz) of the product.

The test result in this report refers exclusively to the presented test model / sample.

Without written approval of SPORTON International Inc., the test report shall not be reproduced except in full.

The measurements and test results shown in this test report were made in accordance with the procedures and found in compliance with the limit given in ANSI C63.4-2003 and 47 CFR FCC Part 15 Subpart E.

The test equipment used to perform the test is calibrated and traceable to NML/ROC.





## Table of Contents

<b>1. CERTIFICATE OF COMPLIANCE .....</b>	<b>1</b>
<b>2. SUMMARY OF THE TEST RESULT .....</b>	<b>2</b>
<b>3. GENERAL INFORMATION .....</b>	<b>3</b>
3.1. Product Details.....	3
3.2. Accessories.....	4
3.3. Table for Filed Antenna.....	5
3.4. Table for Carrier Frequencies .....	6
3.5. Table for Test Modes.....	7
3.6. Table for Testing Locations.....	8
3.7. Table for Class II Change .....	8
3.8. Table for Supporting Units .....	8
3.9. Table for Parameters of Test Software Setting .....	9
3.10. Test Configurations .....	12
<b>4. TEST RESULT .....</b>	<b>21</b>
4.1. AC Power Line Conducted Emissions Measurement.....	21
4.2. 99% Occupied Bandwidth Measurement .....	35
4.3. Maximum Conducted Output Power Measurement.....	102
4.4. Power Spectral Density Measurement .....	224
4.5. Peak Excursion Measurement.....	292
4.6. Radiated Emissions Measurement .....	359
4.7. Band Edge Emissions Measurement .....	579
4.8. Frequency Stability Measurement .....	616
4.9. Antenna Requirements .....	623
<b>5. LIST OF MEASURING EQUIPMENTS .....</b>	<b>624</b>
<b>6. TEST LOCATION.....</b>	<b>626</b>
<b>7. TAF CERTIFICATE OF ACCREDITATION .....</b>	<b>627</b>
<b>APPENDIX A. TEST PHOTOS .....</b>	<b>A1 ~ A12</b>
<b>APPENDIX B. MAXIMUM PERMISSIBLE EXPOSURE .....</b>	<b>B1 ~ B4</b>



### History of This Test Report

Original Issue Date: Apr. 29, 2010

Report No.: FR972826-01

- No additional attachment.
- Additional attachment were issued as following record:

Attachment No.	Issue Date	Description



## 1. CERTIFICATE OF COMPLIANCE

Product Name : MB82 Access Point Radio Module  
Brand Name : Motorola  
Model Name : AP-650(MB82)  
Applicant : Motorola, Inc.  
Test Rule Part(s) : 47 CFR FCC Part 15 Subpart E § 15.407

Sporton International as requested by the applicant to evaluate the EMC performance of the product sample received on Aug. 07, 2009 would like to declare that the tested sample has been evaluated and found to be in compliance with the tested rule parts. The data recorded as well as the test configuration specified is true and accurate for showing the sample's EMC nature.

*Jordan Hsiao 2010.4.30*

Jordan Hsiao

SPORTON INTERNATIONAL INC.

## 2. SUMMARY OF THE TEST RESULT

Applied Standard: 47 CFR FCC Part 15 Subpart E				
Part	Rule Section	Description of Test	Result	Under Limit
4.1	15.207	AC Power Line Conducted Emissions	Complies	7.74 dB
4.2	15.407(a)	26dB Spectrum Bandwidth	Complies	-
4.3	15.407(a)	Maximum Conducted Output Power	Complies	0.41 dB
4.4	15.407(a)	Power Spectral Density	Complies	0.18 dB
4.5	15.407(a)	Peak Excursion	Complies	3.08 dB
4.6	15.407(b)	Radiated Emissions	Complies	0.03 dB
4.7	15.407(b)	Band Edge Emissions	Complies	0.04 dB
4.8	15.407(g)	Frequency Stability	Complies	-
4.9	15.203	Antenna Requirements	Complies	-

Test Items	Uncertainty	Remark
AC Power Line Conducted Emissions	±2.3dB	Confidence levels of 95%
Maximum Conducted Output Power	±0.5dB	Confidence levels of 95%
Power Spectral Density	±0.5dB	Confidence levels of 95%
Peak Excursion	±0.5dB	Confidence levels of 95%
26dB Spectrum Bandwidth / Frequency Stability	±8.5×10 <sup>-8</sup>	Confidence levels of 95%
Radiated Emissions (9kHz~30MHz)	±0.8dB	Confidence levels of 95%
Radiated Emissions (30MHz~1000MHz)	±1.9dB	Confidence levels of 95%
Radiated / Band Edge Emissions (1GHz~18GHz)	±1.9dB	Confidence levels of 95%
Radiated Emissions (18GHz~40GHz)	±1.9dB	Confidence levels of 95%
Temperature	±0.7°C	Confidence levels of 95%
Humidity	±3.2%	Confidence levels of 95%
DC / AC Power Source	±1.4%	Confidence levels of 95%

### 3. GENERAL INFORMATION

#### 3.1. Product Details

##### 802.11n

Items	Description
Product Type	WLAN (2TX, 3RX)
Radio Type	Intentional Transceiver
Power Type	From Host System
Modulation	see the below table for 802.11n
Data Modulation	OFDM (BPSK / QPSK / 16QAM / 64QAM)
Data Rate (Mbps)	see the below table for 802.11n
Frequency Range	5250 ~ 5350MHz / 5470 ~ 5725MHz
Channel Number	12 for 20MHz bandwidth ; 5 for 40MHz bandwidth
Channel Band Width (99%)	MCS8 (20MHz): 18.56 MHz ; MCS8 (40MHz): 37.44 MHz
Conducted Output Power	Band 2: MCS8 (20MHz): 23.25 dBm ; MCS8 (40MHz): 23.59 dBm Band 3: MCS8 (20MHz): 23.27 dBm ; MCS8 (40MHz): 23.47 dBm
Carrier Frequencies	Please refer to section 3.4
Antenna	Please refer to section 3.3

##### 802.11a

Items	Description
Product Type	WLAN (2TX, 3RX)
Radio Type	Intentional Transceiver
Power Type	From Host System
Modulation	OFDM for IEEE 802.11a
Data Modulation	OFDM (BPSK / QPSK / 16QAM / 64QAM)
Data Rate (Mbps)	OFDM (6/9/12/18/24/36/48/54)
Frequency Range	5250 ~ 5350MHz / 5470 ~ 5725MHz
Channel Number	12
Channel Band Width (99%)	17.92 MHz
Conducted Output Power	Band 2: 22.81 dBm ; Band 3: 22.55 dBm
Carrier Frequencies	Please refer to section 3.4
Antenna	Please refer to section 3.3

**Antenna & Band width**

Antenna	Two (TX)	
Band width Mode	20 MHz	40 MHz
802.11a	V	X
802.11n	V	V

**802.11n spec**

MCS Index	Nss	Modulation	R	NBPS	NCBPS		NDBPS		Datarate(Mbps)			
					20MHz	40MHz	20MHz	40MHz	800nsGI		400nsGI	
									20MHz	40MHz	20MHz	40MHz
0	1	BPSK	1/2	1	52	108	26	54	6.5	13.5	7.200	15
1	1	QPSK	1/2	2	104	216	52	108	13.0	27.0	14.400	30
2	1	QPSK	3/4	2	104	216	78	162	19.5	40.5	21.700	45
3	1	16-QAM	1/2	4	208	432	104	216	26.0	54.0	28.900	60
4	1	16-QAM	3/4	4	208	432	156	324	39.0	81.0	43.300	90
5	1	64-QAM	2/3	6	312	648	208	432	52.0	108.0	57.800	120
6	1	64-QAM	3/4	6	312	648	234	486	58.5	121.5	65.000	135
7	1	64-QAM	5/6	6	312	648	260	540	65.0	135.0	72.200	150
8	2	BPSK	1/2	1	104	216	52	108	13.0	27.0	14.444	30
9	2	QPSK	1/2	2	208	432	104	216	26.0	54.0	28.889	60
10	2	QPSK	3/4	2	208	432	156	324	39.0	81.0	43.333	90
11	2	16-QAM	1/2	4	416	864	208	432	52.0	108.0	57.778	120
12	2	16-QAM	3/4	4	416	864	312	648	78.0	162.0	86.667	180
13	2	64-QAM	2/3	6	624	1296	416	864	104.0	216.0	115.556	240
14	2	64-QAM	3/4	6	624	1296	468	972	117.0	243.0	130.000	270
15	2	64-QAM	5/6	6	624	1296	520	1080	130.0	270.0	144.444	300

Symbol	Explanation
NSS	Number of spatial streams
R	Code rate
NBPS	Number of coded bits per single carrier
NCBPS	Number of coded bits per symbol
NDBPS	Number of data bits per symbol
GI	guard interval

**3.2. Accessories**

N/A

### 3.3. Table for Filed Antenna

Ant.	Brand	Model Name	Antenna Type	Connector	Frequency Band	Antenna Gain (dBi)
1	Symbol	ML-2452-APA2-01	Dipole Antenna	Reversed-SMA	2.4GHz	7
	Symbol	ML-2452-APA2-01	Dipole Antenna	Reversed-SMA	5GHz	7
2	MOTOROLA	RPAA-M1	Embedded Antenna	I-PEX	2.4GHz	2
	MOTOROLA	RPAA-M1	Embedded Antenna	I-PEX	5GHz	3.42
3	Symbol	ML-2499-SD3-01R	Patch Antenna	RP-BNC Male	2.4GHz	3.5
	Symbol	ML-5299-PTA1-01R	Patch Antenna	RP-SMA Male	5GHz	3
4	Symbol	ML-2499-HPA3-01R	Omni Antenna	RP-BNC Male	2.4GHz	3.3
	Symbol	ML-5299-HPA1-01R	Omni Antenna	RP-SMA Male	5GHz	4.2
5	Symbol	ML-2452-PNA5-01R	Panel Antenna	N Type Male	2.4GHz	4.5
	Symbol	ML-2452-PNA5-01R	Panel Antenna	N Type Male	5GHz	5
6	Symbol	ML-2452-PTA3M3-036	Omni Antenna	RP-SMA Male	2.4GHz	4
	Symbol	ML-2452-PTA3M3-036	Omni Antenna	RP-SMA Male	5GHz	7

Test external cable is used to connect the EUT and antenna.

#### Loss of External Cable list

Ant.	Frequency Band	Loss of External Cable (dB)
1	2.4GHz	0.65
	5GHz	1.42
2	2.4GHz	-
	5GHz	-
3	2.4GHz	0.65
	5GHz	1.42
4	2.4GHz	0.65
	5GHz	1.42
5	2.4GHz	1.54
	5GHz	2.23
6	2.4GHz	0.65
	5GHz	1.42



**Note:**

The EUT has three antenna connectors which can be used for transmitting and receiving simultaneously as 2Tx and 3Rx. There are six sets of antenna provided to this EUT and all of them can be used as transmitting and receiving antenna.

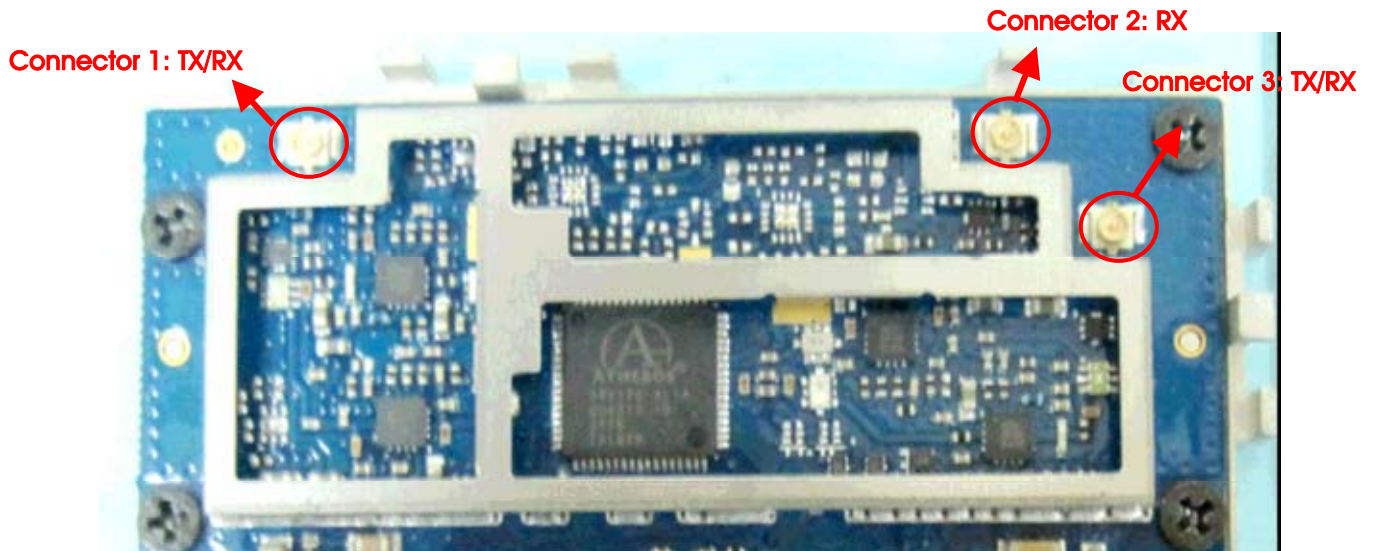

### 3.4. Table for Carrier Frequencies

There are two bandwidth systems for 802.11n.

For both 20MHz bandwidth systems, use Channel 52, 56, 60, 64, 100, 104, 108, 112, 116, 132, 136, 140.

For both 40MHz bandwidth systems, use Channel 54, 62, 102, 110, 134.

Frequency Band	Channel No.	Frequency	Channel No.	Frequency
5250~5350 MHz Band 2	52	5260 MHz	60	5300 MHz
	54	5270 MHz	62	5310 MHz
	56	5280 MHz	64	5320 MHz
5470~5725 MHz Band 3	100	5500 MHz	116	5580 MHz
	102	5510MHz	132	5660 MHz
	104	5520 MHz	134	5670 MHz
	108	5540 MHz	136	5680 MHz
	110	5550 MHz	140	5700 MHz
	112	5560 MHz		

### 3.5. Table for Test Modes

Preliminary tests were performed in different data rate to find the worst radiated emission. The data rate shown in the table below is the worst-case rate with respect to the specific test item. Investigation has been done on all the possible configurations for searching the worst cases. The following table is a list of the test modes shown in this test report.

Test Items	Mode		Data Rate	Channel	Antenna
AC Power Conducted Emission	Normal Link		Auto	-	-
Max. Conducted Output Power	MCS8/20MHz	Band 2	13Mbps	52/60/64	1/2/3/4/5/6
		Band 3	13Mbps	100/116/140	1/2/3/4/5/6
	MCS8/40MHz	Band 2	27Mbps	54/62	1/2/3/4/5/6
		Band 3	27Mbps	102/110/134	1/2/3/4/5/6
	11a/BPSK	Band 2	6Mbps	52/60/64	1/2/3/4/5/6
		Band 3	6Mbps	100/116/140	1/2/3/4/5/6
26dB Spectrum Bandwidth 99% Occupied Bandwidth Measurement Power Spectral Density Peak Excursion	MCS8/20MHz	Band 2	13Mbps	52/60/64	1/2/3/4/5/6
		Band 3	13Mbps	100/116/140	1/2/3/4/5/6
	MCS8/40MHz	Band 2	27Mbps	54/62	1/2/3/4/5/6
		Band 3	27Mbps	102/110/134	1/2/3/4/5/6
	11a/BPSK	Band 2	6Mbps	52/60/64	1/2/3/4/5/6
		Band 3	6Mbps	100/116/140	1/2/3/4/5/6
Radiated Emission Below 1GHz	Normal Link		Auto	-	-
Radiated Emission Above 1GHz	MCS8/20MHz	Band 2	13Mbps	52/60/64	1/2/3/4/5/6
		Band 3	13Mbps	100/116/140	1/2/3/4/5/6
	MCS8/40MHz	Band 2	27Mbps	54/62	1/2/3/4/5/6
		Band 3	27Mbps	102/110/134	1/2/3/4/5/6
	11a/BPSK	Band 2	6Mbps	52/60/64	1/2/3/4/5/6
		Band 3	6Mbps	100/116/140	1/2/3/4/5/6
Band Edge Emission	MCS8/20MHz	Band 2	13Mbps	52/60/64	1/2/3/4/5/6
		Band 3	13Mbps	100/116/140	1/2/3/4/5/6
	MCS8/40MHz	Band 2	27Mbps	54/62	1/2/3/4/5/6
		Band 3	27Mbps	102/110/134	1/2/3/4/5/6
	11a/BPSK	Band 2	6Mbps	52/60/64	1/2/3/4/5/6
		Band 3	6Mbps	100/116/140	1/2/3/4/5/6
Frequency Stability	Un-modulation		-	60	N/A

### 3.6. Table for Testing Locations

Test Site No.	Site Category	Location	FCC Reg. No.	IC File No.	VCCI Reg. No
03CH03-HY	SAC	Hwa Ya	480872	IC 4086	-
CO04-HY	Conduction	Hwa Ya	480872	IC 4086	-
TH01-HY	OVEN Room	Hwa Ya	480872	IC 4086	-

Open Area Test Site (OATS); Semi Anechoic Chamber (SAC); Fully Anechoic Chamber (FAC).

Please refer section 6 for Test Site Address.

### 3.7. Table for Class II Change

Add 802.11a Band 2 and Band 3 (5250~5350MHz and 5470~5725MHz).

There is no change in hardware or in existing RF relevant portion. Restricted Band 5.60 – 5.65 GHz.

### 3.8. Table for Supporting Units

Support Unit	Brand	Model	FCC ID
Notebook	DELL	D400	E2K24GBRL
Mouse	iCooky	AMS0706W	DoC
Modem	ACEEX	DM1414	IFAXDM1414
Printer	EPSON	LQ-300+	DoC
Notebook	DELL	D505	E2K24GBRL

### 3.9. Table for Parameters of Test Software Setting

During testing, Channel & Power Controlling Software provided by the customer was used to control the operating channel as well as the output power level. The RF output power selection is for the setting of RF output power expected by the customer and is going to be fixed on the firmware of the final end product.

<For Antenna 1>:

#### Power Parameters of 802.11n MCS8 20MHz

Test Software Version	ART					
Frequency	5260 MHz	5300 MHz	5320 MHz	5500 MHz	5580 MHz	5700 MHz
802.11n 20MHz Ant. 1	17	17	14.5	12	17.5	12

#### Power Parameters of 802.11n MCS8 40MHz

Test Software Version	ART				
Frequency	5270 MHz	5310 MHz	5510 MHz	5550 MHz	5670 MHz
802.11n 40MHz Ant. 1	16.5	11	10	17.5	14

#### Power Parameters of IEEE 802.11a

Test Software Version	ART					
Frequency	5260 MHz	5300 MHz	5320 MHz	5500 MHz	5580 MHz	5700 MHz
IEEE 11a Ant. 1	17	17	14.5	11.5	17	12

<For Antenna 2>:

#### Power Parameters of 802.11n MCS8 20MHz

Test Software Version	ART					
Frequency	5260 MHz	5300 MHz	5320 MHz	5500 MHz	5580 MHz	5700 MHz
802.11n 20MHz Ant. 2	18	16	16	18	18	16

#### Power Parameters of 802.11n MCS8 40MHz

Test Software Version	ART				
Frequency	5270 MHz	5310 MHz	5510 MHz	5550 MHz	5670 MHz
802.11n 40MHz Ant. 2	18	14	18	18	16

#### Power Parameters of IEEE 802.11a

Test Software Version	ART					
Frequency	5260 MHz	5300 MHz	5320 MHz	5500 MHz	5580 MHz	5700 MHz
IEEE 11a Ant. 2	17.5	15	14.5	17	17	15.5

<For Antenna 3>:

**Power Parameters of 802.11n MCS8 20MHz**

Test Software Version	ART					
Frequency	5260 MHz	5300 MHz	5320 MHz	5500 MHz	5580 MHz	5700 MHz
802.11n 20MHz Ant. 3	18	18	16	15	18	13.5

**Power Parameters of 802.11n MCS8 40MHz**

Test Software Version	ART				
Frequency	5270 MHz	5310 MHz	5510 MHz	5550 MHz	5670 MHz
802.11n 40MHz Ant. 3	18	13.5	11.5	18	15

**Power Parameters of IEEE 802.11a**

Test Software Version	ART					
Frequency	5260 MHz	5300 MHz	5320 MHz	5500 MHz	5580 MHz	5700 MHz
IEEE 11a Ant. 3	17.5	17.5	16	15	17	13.5

<For Antenna 4>:

**Power Parameters of 802.11n MCS8 20MHz**

Test Software Version	ART					
Frequency	5260 MHz	5300 MHz	5320 MHz	5500 MHz	5580 MHz	5700 MHz
802.11n 20MHz Ant. 4	18	18	16	14	18	12

**Power Parameters of 802.11n MCS8 40MHz**

Test Software Version	ART				
Frequency	5270 MHz	5310 MHz	5510 MHz	5550 MHz	5670 MHz
802.11n 40MHz Ant. 4	17	11.5	9	16.5	14

**Power Parameters of IEEE 802.11a**

Test Software Version	ART					
Frequency	5260 MHz	5300 MHz	5320 MHz	5500 MHz	5580 MHz	5700 MHz
IEEE 11a Ant. 4	17.5	17.5	15	14	17	14

<For Antenna 5>:

**Power Parameters of 802.11n MCS8 20MHz**

Test Software Version	ART					
Frequency	5260 MHz	5300 MHz	5320 MHz	5500 MHz	5580 MHz	5700 MHz
802.11n 20MHz Ant. 5	18	18	14.5	13.5	18	11

**Power Parameters of 802.11n MCS8 40MHz**

Test Software Version	ART				
Frequency	5270 MHz	5310 MHz	5510 MHz	5550 MHz	5670 MHz
802.11n 40MHz Ant. 5	18	12	10	16.5	13.5

**Power Parameters of IEEE 802.11a**

Test Software Version	ART					
Frequency	5260 MHz	5300 MHz	5320 MHz	5500 MHz	5580 MHz	5700 MHz
IEEE 11a Ant. 5	17.5	17.5	15	12.5	17	10

<For Antenna 6>:

**Power Parameters of 802.11n MCS8 20MHz**

Test Software Version	ART					
Frequency	5260 MHz	5300 MHz	5320 MHz	5500 MHz	5580 MHz	5700 MHz
802.11n 20MHz Ant. 6	17	17.5	14	13.5	17.5	12

**Power Parameters of 802.11n MCS8 40MHz**

Test Software Version	ART				
Frequency	5270 MHz	5310 MHz	5510 MHz	5550 MHz	5670 MHz
802.11n 40MHz Ant. 6	17	10.5	8	16	13

**Power Parameters of IEEE 802.11a**

Test Software Version	ART					
Frequency	5260 MHz	5300 MHz	5320 MHz	5500 MHz	5580 MHz	5700 MHz
IEEE 11a Ant. 6	17	17	14	12.5	17	10

During the test, the following programs under WIN XP were executed:

Executed "ART" to control the EUT continuously transmit RF signal.

### 3.10. Test Configurations

#### 3.10.1. Radiation Emissions Test Configuration

Test Configuration: 9kHz~1GHz

<For Antenna 1>:

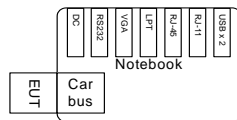
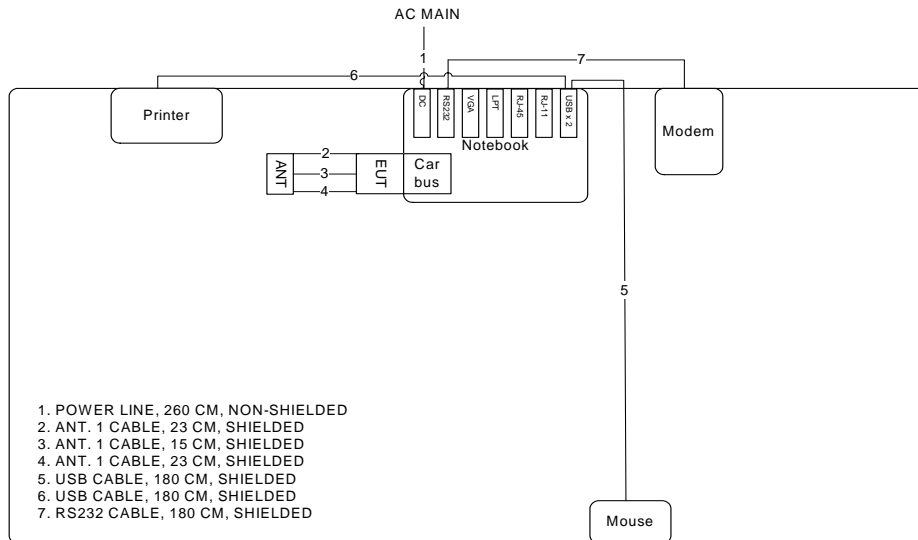

<For Antenna 2>:

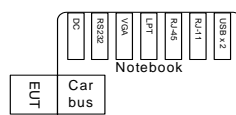
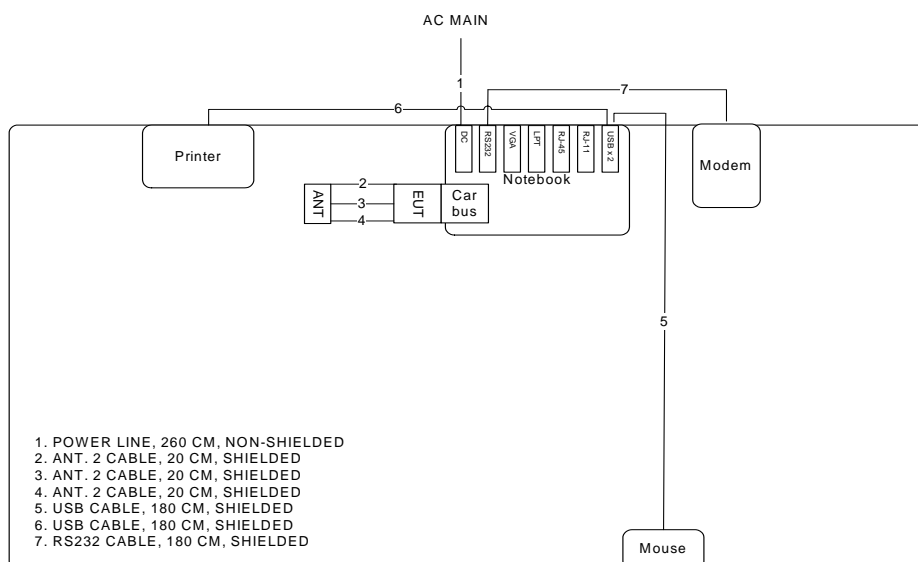

<For Antenna 3>:

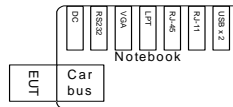
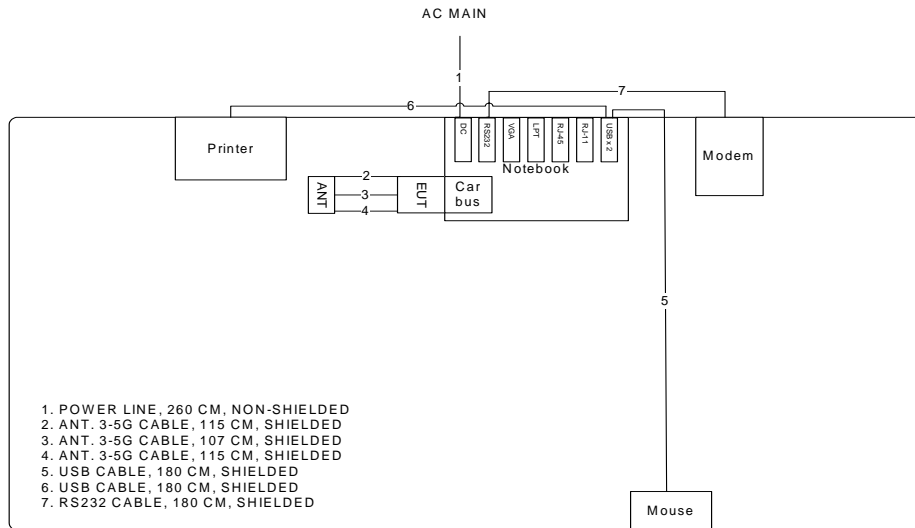

<For Antenna 4>:

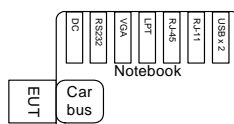
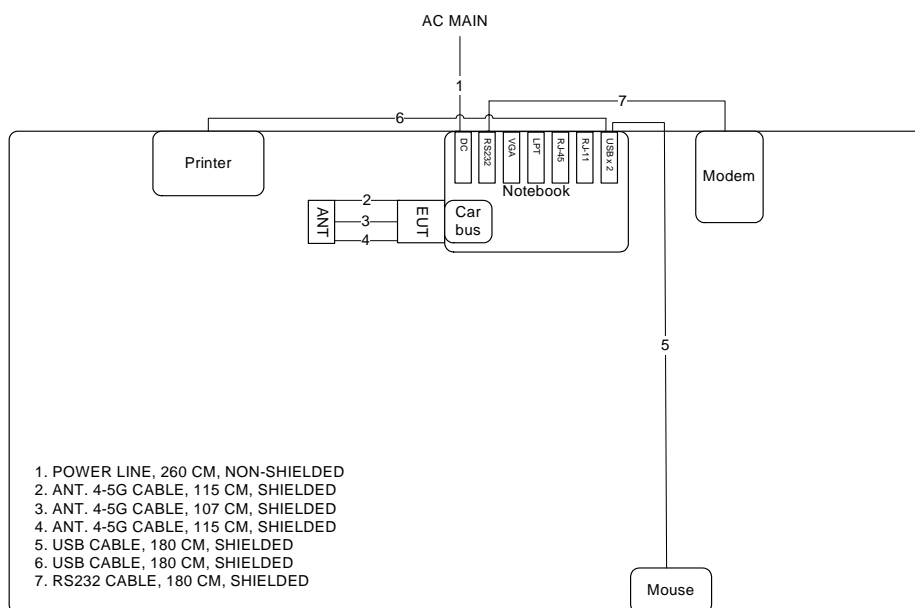



<For Antenna 5>:

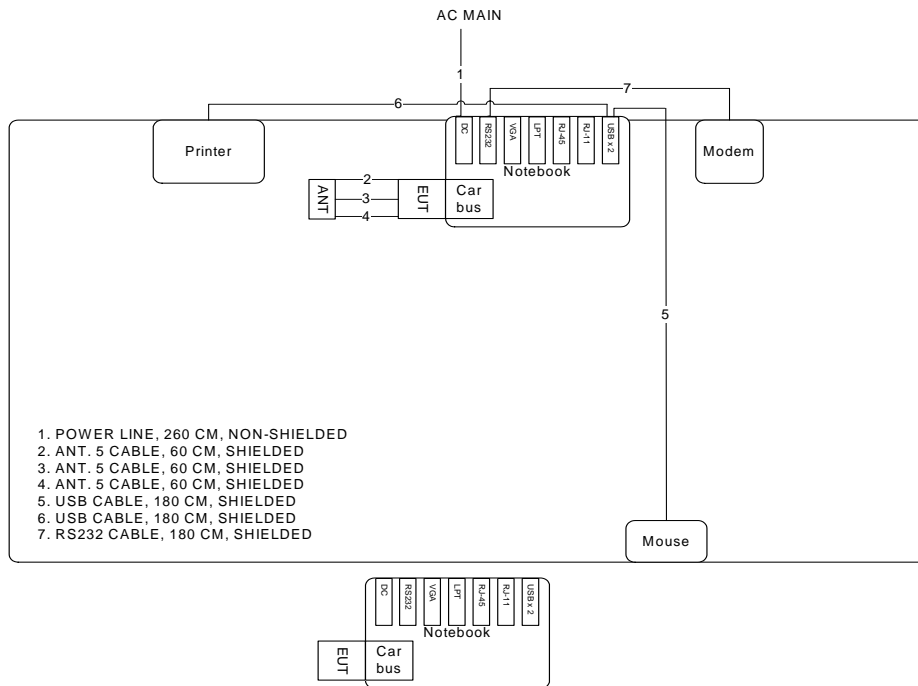

<For Antenna 6>:

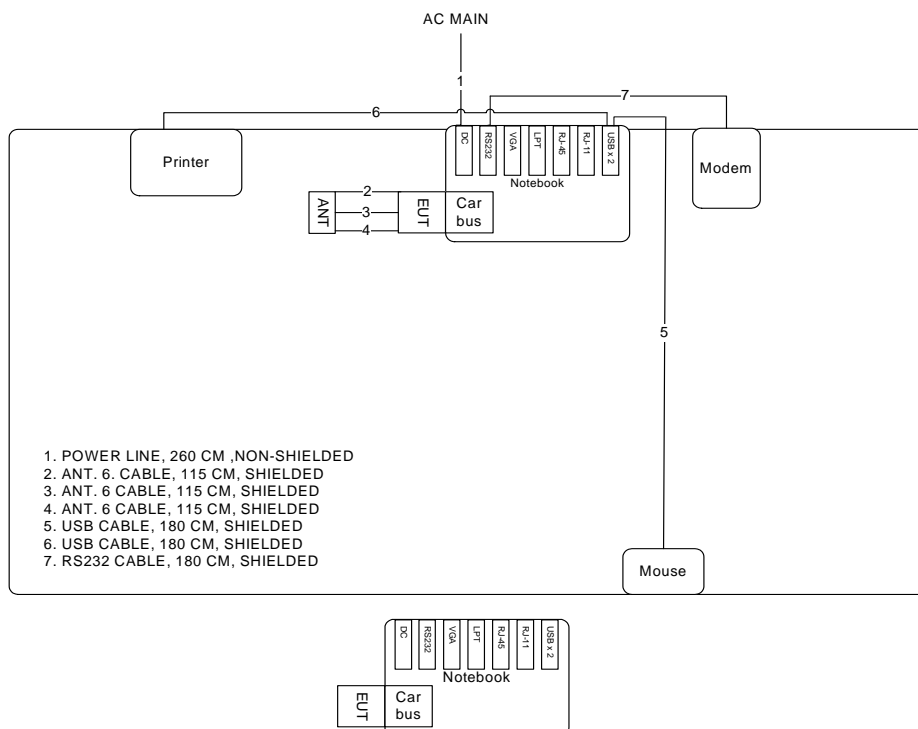

Test Configuration: above 1GHz

<For Antenna 1>:

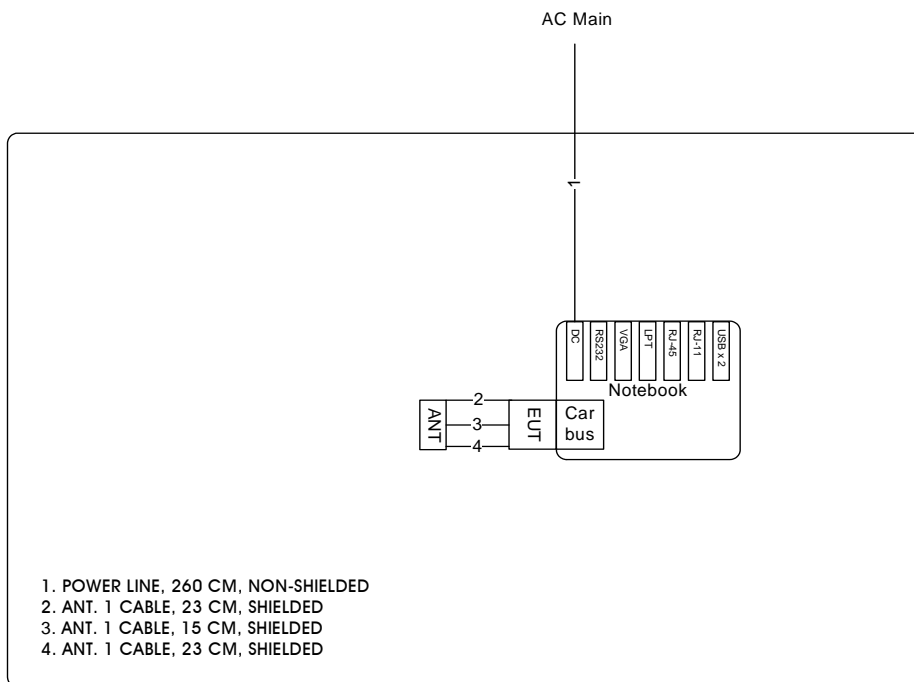

<For Antenna 2>:

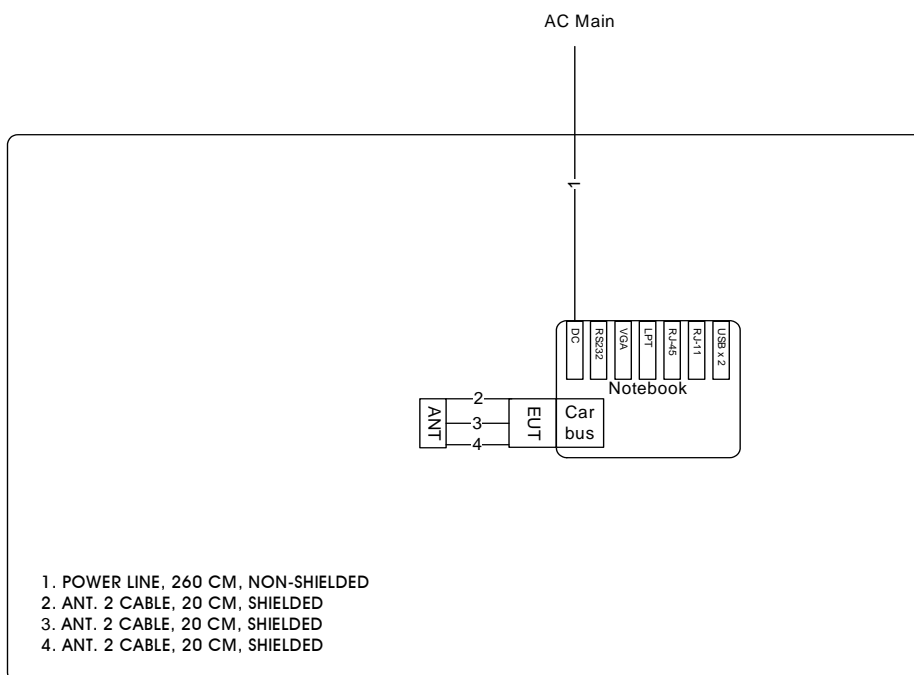

<For Antenna 3>:

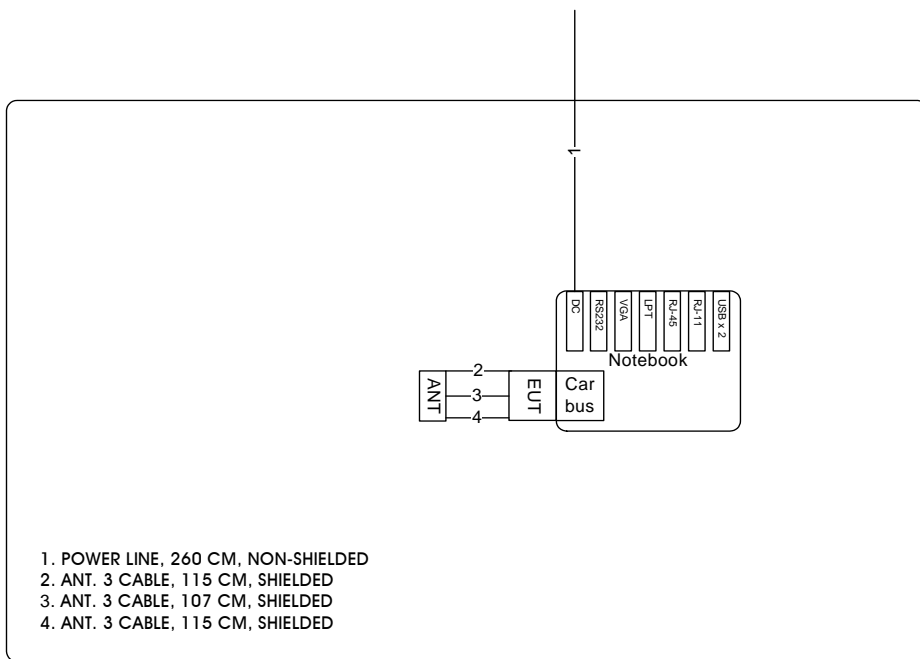

<For Antenna 4>:

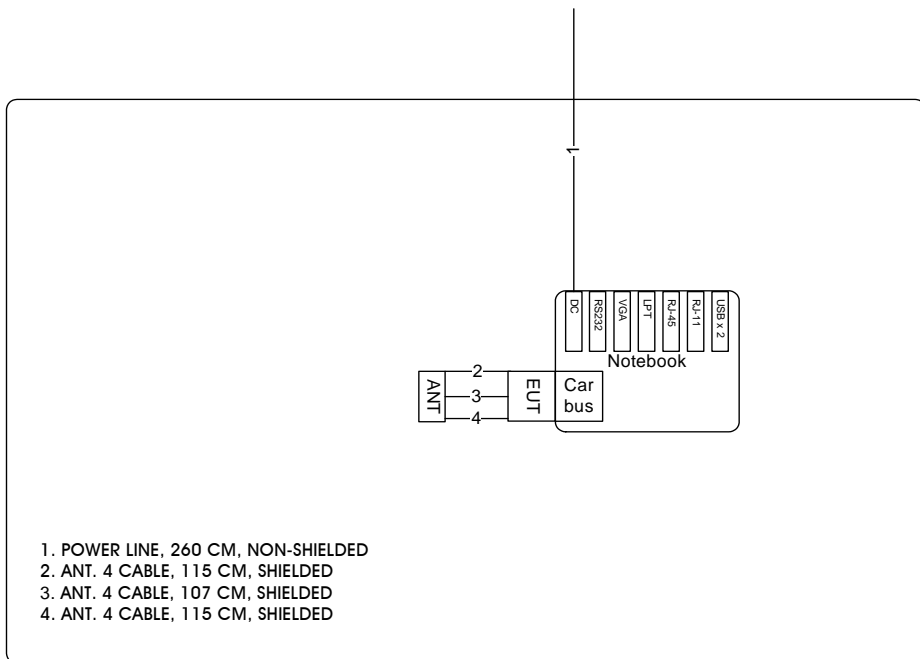

<For Antenna 5>:

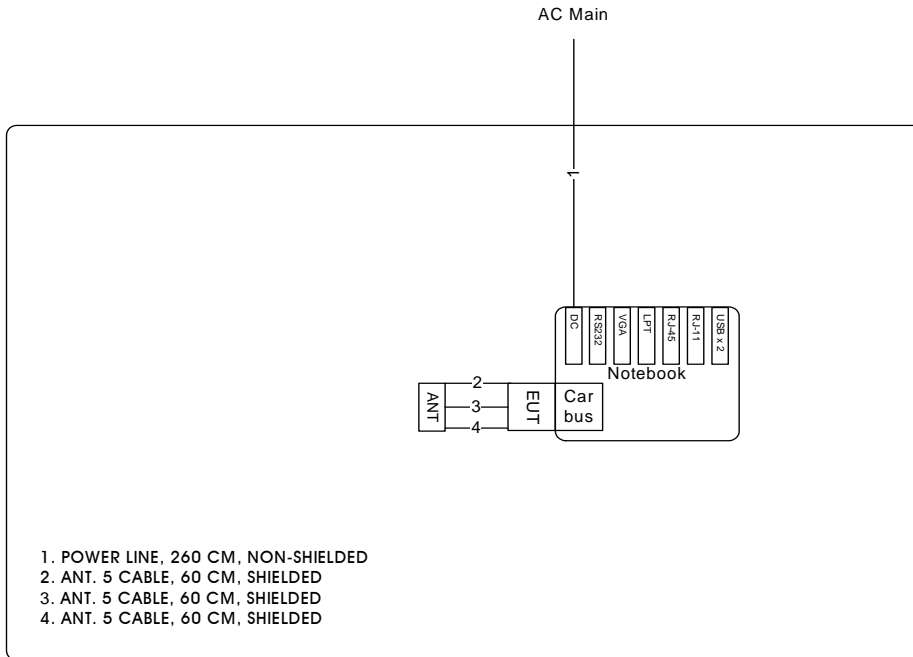

<For Antenna 6>:

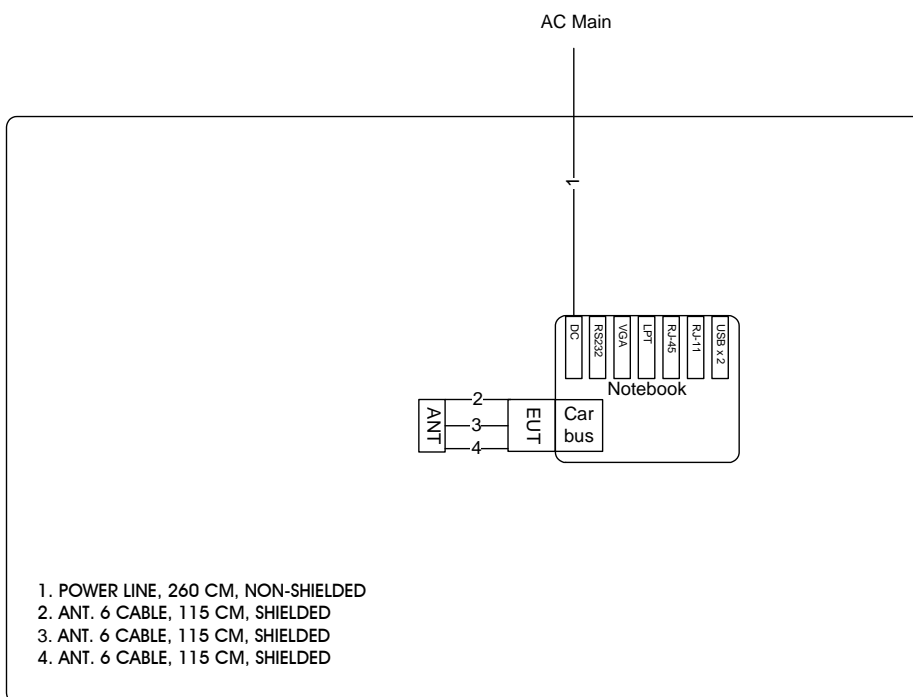

### 3.10.2. AC Power Line Conduction Emissions Test Configuration

<For Antenna 1 >:

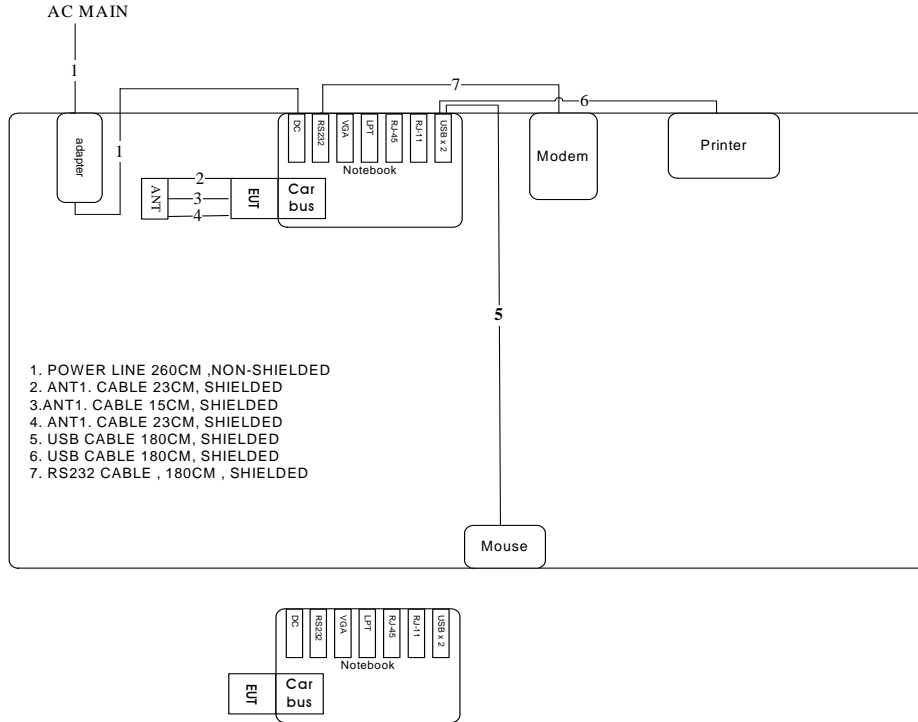

<For Antenna 2 >:

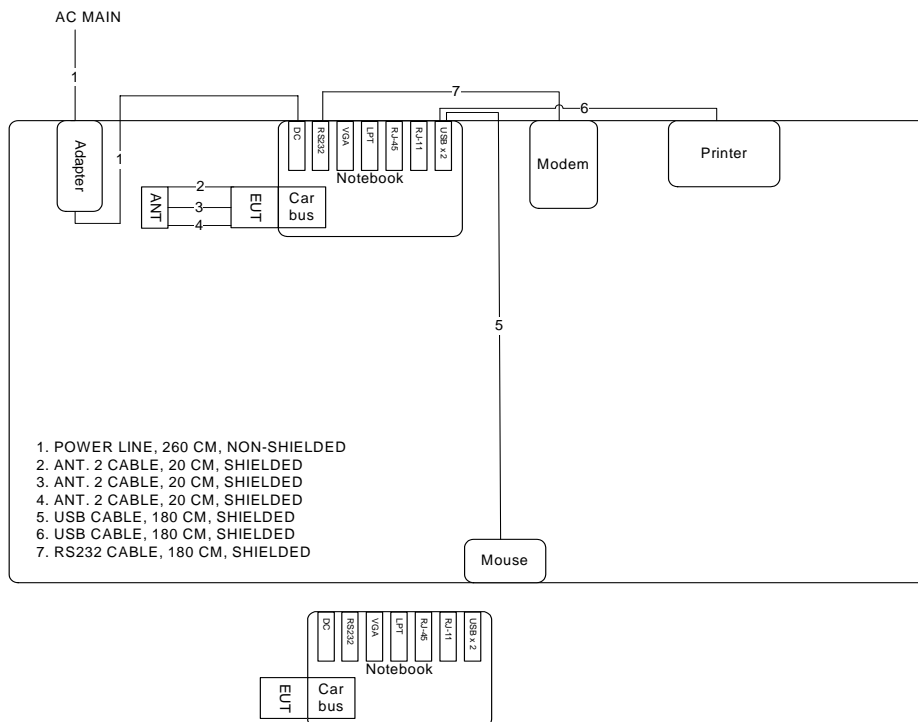

<For Antenna 3>:

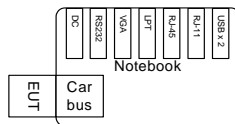
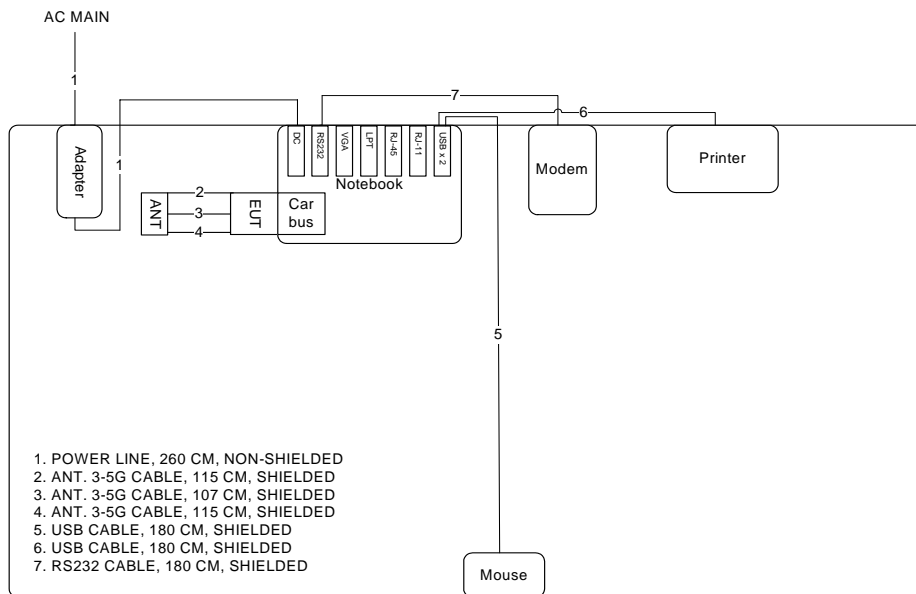

<For Antenna 4>:

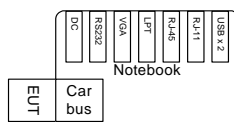
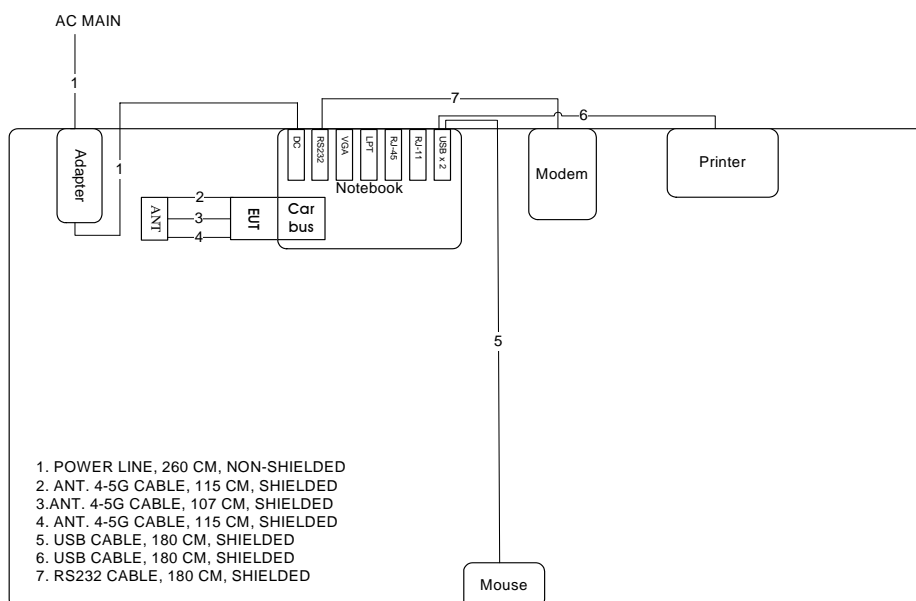

<For Antenna 5>:

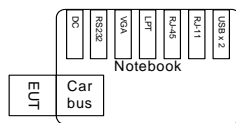
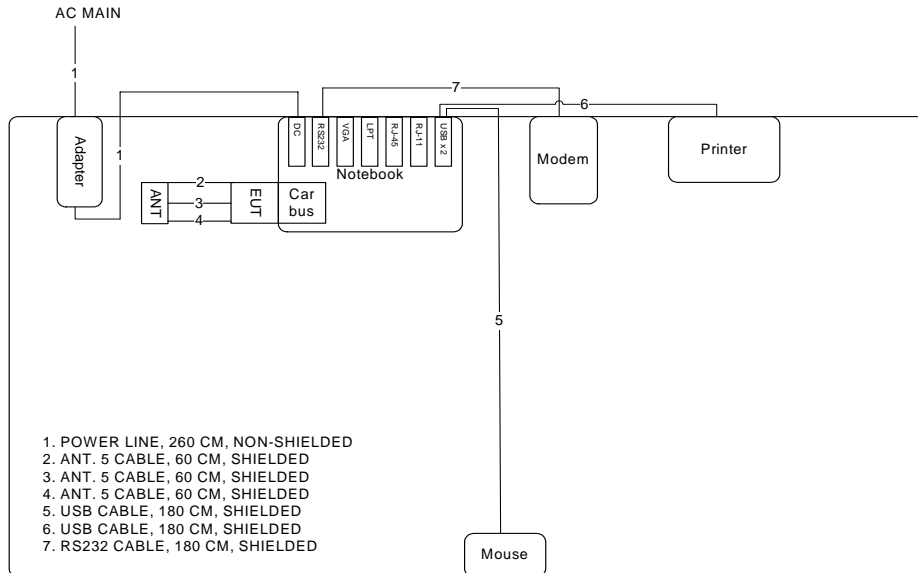

<For Antenna 6>:

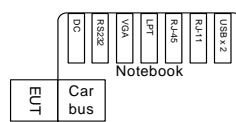
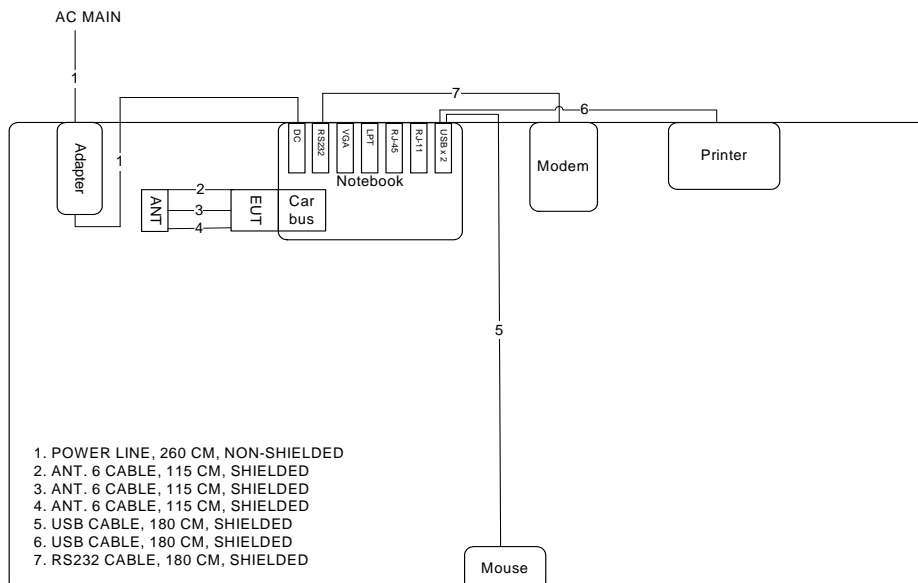

## 4. TEST RESULT

### 4.1. AC Power Line Conducted Emissions Measurement

#### 4.1.1. Limit

For this product that is designed to connect to the AC power line, the radio frequency voltage that is conducted back onto the AC power line on any frequency or frequencies within the band 150 kHz to 30 MHz shall not exceed below limits table.

Frequency (MHz)	QP Limit (dBuV)	AV Limit (dBuV)
0.15~0.5	66~56	56~46
0.5~5	56	46
5~30	60	50

#### 4.1.2. Measuring Instruments and Setting

Please refer to section 5 of equipments list in this report. The following table is the setting of the receiver.

Receiver Parameters	Setting
Attenuation	10 dB
Start Frequency	0.15 MHz
Stop Frequency	30 MHz
IF Bandwidth	9 KHz

#### 4.1.3. Test Procedures

1. Configure the EUT according to ANSI C63.4. The EUT or host of EUT has to be placed 0.4 meter far from the conducting wall of the shielding room and at least 80 centimeters from any other grounded conducting surface.
2. Connect EUT or host of EUT to the power mains through a line impedance stabilization network (LISN).
3. All the support units are connected to the other LISNs. The LISN should provide 50uH/50ohms coupling impedance.
4. The frequency range from 150 KHz to 30 MHz was searched.
5. Set the test-receiver system to Peak Detect Function and Specified Bandwidth with Maximum Hold Mode.
6. The measurement has to be done between each power line and ground at the power terminal.



#### 4.1.4. Test Setup Layout

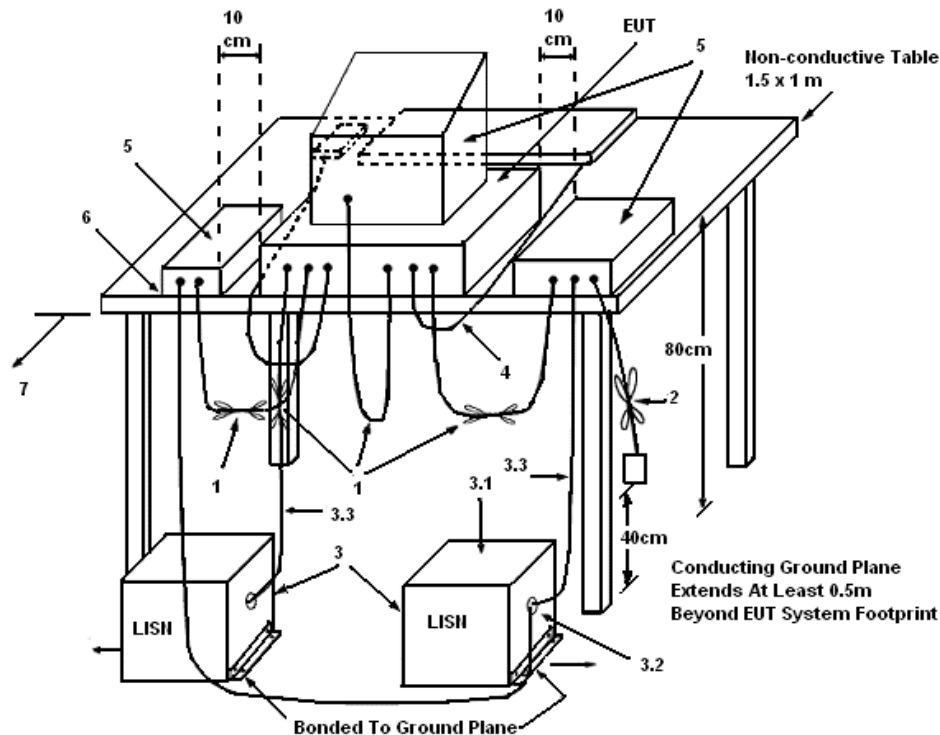

#### LEGEND:

- (1) Interconnecting cables that hang closer than 40 cm to the ground plane shall be folded back and forth in the center forming a bundle 30 to 40 cm long.
- (2) I/O cables that are not connected to a peripheral shall be bundled in the center. The end of the cable may be terminated, if required, using the correct terminating impedance. The overall length shall not exceed 1 m.
- (3) EUT connected to one LISN. Unused LISN measuring port connectors shall be terminated in 50  $\Omega$ . LISN can be placed on top of, or immediately beneath, reference ground plane.
  - (3.1) All other equipment powered from additional LISN(s).
  - (3.2) Multiple outlet strip can be used for multiple power cords of non-EUT equipment.
  - (3.3) LISN at least 80 cm from nearest part of EUT chassis.
- (4) Cables of hand-operated devices, such as keyboards, mice, etc., shall be placed as for normal use.
- (5) Non-EUT components of EUT system being tested.
- (6) Rear of EUT, including peripherals, shall all be aligned and flush with rear of tabletop.
- (7) Rear of tabletop shall be 40 cm removed from a vertical conducting plane that is bonded to the ground plane.

#### 4.1.5. Test Deviation

There is no deviation with the original standard.

#### 4.1.6. EUT Operation during Test

The EUT was placed on the test table and programmed in normal function.

4.1.7. Results of AC Power Line Conducted Emissions Measurement

<For Antenna 1 >:

Temperature	24°C	Humidity	56%
Test Engineer	Peter Wu	Phase	Line
Configuration	Normal Link / Antenna 1		

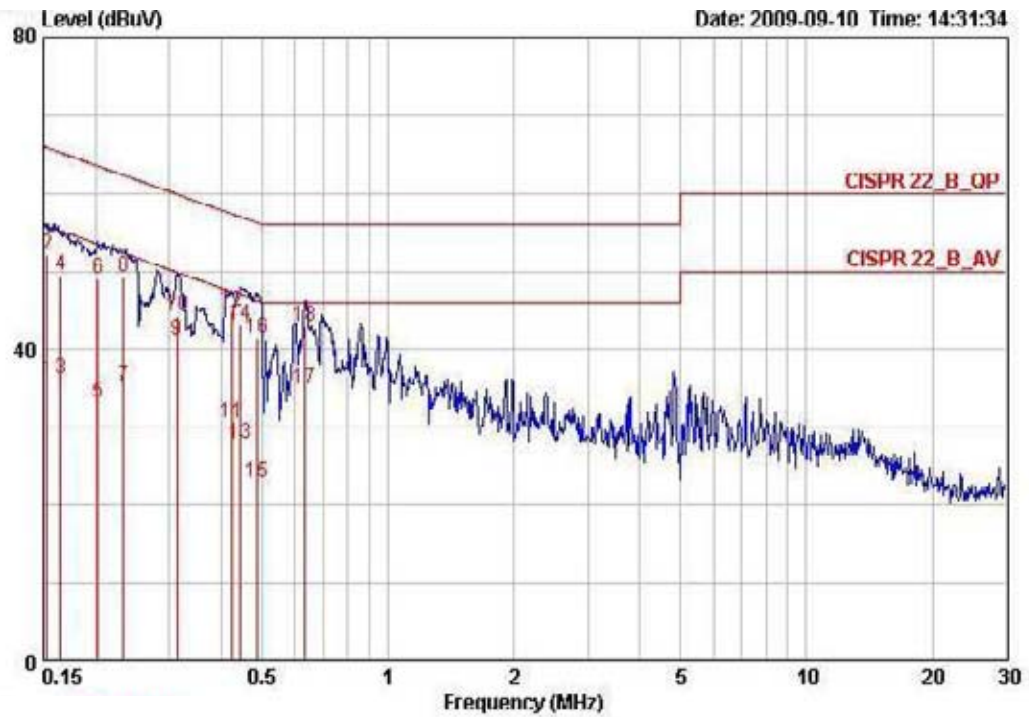

	Freq	Level	Over Limit	Limit Line	Read Level	LISN Factor	Cable Loss	Remark
	MHz	dBuV	dB	dBuV	dBuV	dB	dB	
1	0.15321	36.01	-19.01	55.02	35.74	0.07	0.20	AVERAGE
2	0.15321	52.02	-13.80	65.82	51.75	0.07	0.20	QP
3	0.16501	36.17	-19.04	55.21	35.90	0.07	0.20	AVERAGE
4	0.16501	49.47	-15.74	65.21	49.20	0.07	0.20	QP
5	0.20289	33.15	-20.34	53.49	32.90	0.05	0.20	AVERAGE
6	0.20289	40.97	-14.52	63.49	40.72	0.05	0.20	QP
7	0.23285	35.40	-16.95	52.35	35.15	0.05	0.20	AVERAGE
8	0.23285	49.36	-12.99	62.35	49.11	0.05	0.20	QP
9	0.31328	41.12	-8.77	49.88	40.88	0.04	0.20	AVERAGE
10	0.31328	44.25	-15.64	59.88	44.01	0.04	0.20	QP
11	0.42150	30.49	-16.93	47.42	30.26	0.03	0.20	AVERAGE
12	0.42150	45.01	-12.41	57.42	44.78	0.03	0.20	QP
13	0.44443	27.86	-19.12	46.98	27.63	0.03	0.20	AVERAGE
14	0.44443	43.22	-13.76	56.98	42.99	0.03	0.20	QP
15	0.48632	22.87	-23.36	46.23	22.73	0.03	0.11	AVERAGE
16	0.48632	41.45	-14.78	56.23	41.31	0.03	0.11	QP
17	0.63018	34.85	-11.15	46.00	34.62	0.03	0.20	AVERAGE
18	0.63018	42.93	-13.07	56.00	42.70	0.03	0.20	QP

Temperature	24°C	Humidity	56%
Test Engineer	Peter Wu	Phase	Neutral
Configuration	Normal Link / Antenna 1		

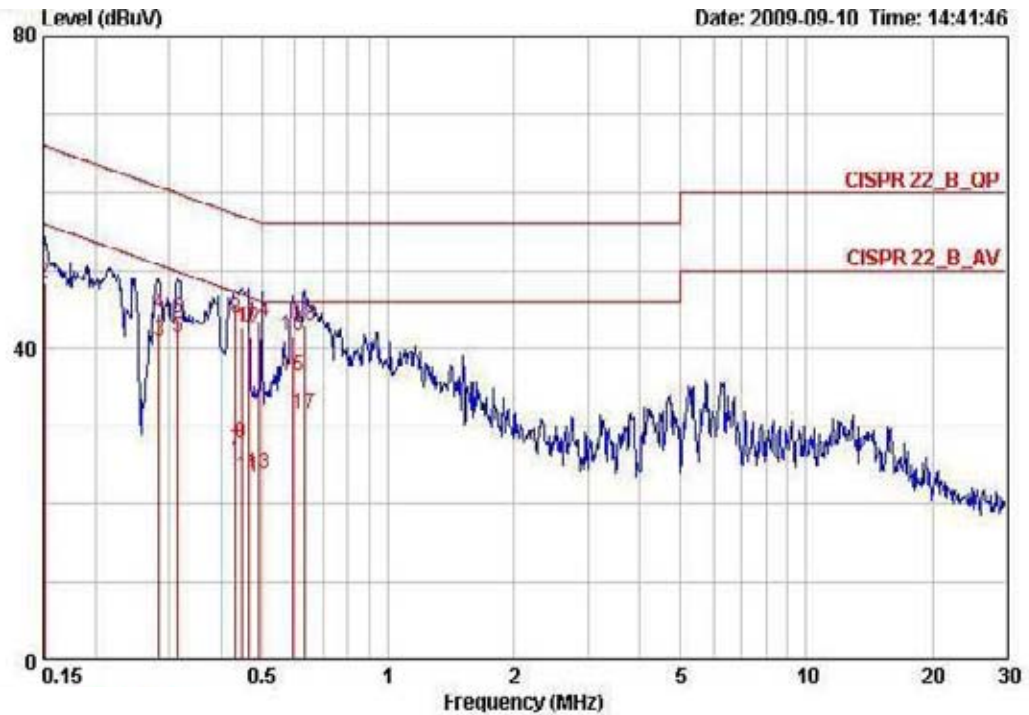

	Freq	Level	Over	Limit	Read	LISN	Cable	Remark
	MHz	dBuV	Limit	Line	Level	Factor	Loss	
			dB	dBuV	dBuV	dB	dB	
1	0.15080	36.15	-19.00	55.96	35.05	0.10	0.20	AVERAGE
2	0.15080	48.31	-17.64	65.96	48.01	0.10	0.20	QP
3	0.28328	40.92	-9.79	50.72	40.65	0.07	0.20	AVERAGE
4	0.28328	44.49	-16.22	60.72	44.22	0.07	0.20	QP
5	0.31495	41.52	-8.32	49.84	41.25	0.07	0.20	AVERAGE
6	0.31495	43.04	-16.00	59.84	43.57	0.07	0.20	QP
7	0.43281	26.79	-20.41	47.20	26.52	0.07	0.20	AVERAGE
8	0.43281	43.90	-13.30	57.20	43.63	0.07	0.20	QP
9	0.44679	27.94	-18.99	46.93	27.67	0.07	0.20	AVERAGE
10	0.44679	42.78	-14.15	56.93	42.51	0.07	0.20	QP
11	0.46614	23.56	-23.02	46.58	23.29	0.07	0.20	AVERAGE
12	0.46614	42.61	-13.97	56.58	42.34	0.07	0.20	QP
13	0.49237	23.93	-22.20	46.13	23.73	0.07	0.13	AVERAGE
14	0.49237	43.37	-12.76	56.13	43.17	0.07	0.13	QP
15	0.59324	36.44	-9.56	46.00	36.17	0.07	0.20	AVERAGE
16	0.59324	41.67	-14.33	56.00	41.40	0.07	0.20	QP
17	0.63383	31.68	-14.32	46.00	31.41	0.07	0.20	AVERAGE
18	0.63383	42.91	-13.09	56.00	42.64	0.07	0.20	QP

Note: Level = Read Level + LISN Factor + Cable Loss

<For Antenna 2>:

Temperature	24°C	Humidity	56%
Test Engineer	Peter Wu	Phase	Line
Configuration	Normal Link / Antenna 2		

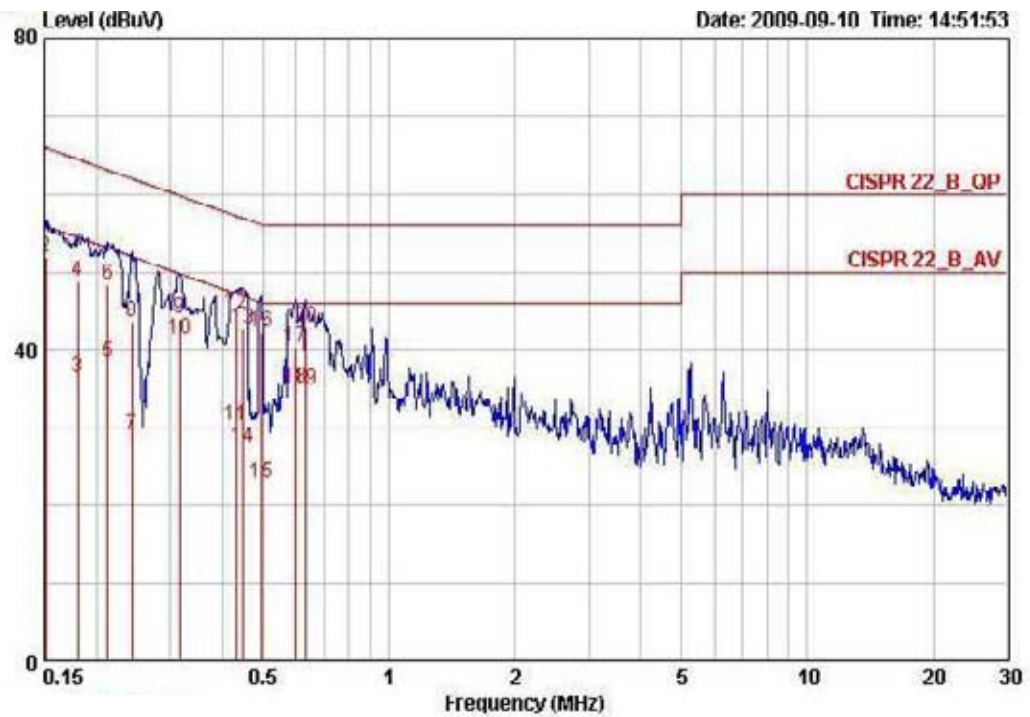

	Freq	Level	Over Limit	Limit Line	Read Level	LISN Factor	Cable Loss	Remark
	MHz	dBuV	dB	dBuV	dBuV	dB	dB	
1	0.15080	36.90	-19.05	55.96	36.63	0.07	0.20	AVERAGE
2	0.15080	51.83	-14.12	65.96	51.56	0.07	0.20	QP
3	0.18056	36.34	-18.12	54.46	36.08	0.06	0.20	AVERAGE
4	0.18056	48.86	-15.60	64.46	48.60	0.06	0.20	QP
5	0.21279	38.37	-14.73	53.10	38.12	0.05	0.20	AVERAGE
6	0.21279	48.47	-14.63	63.10	48.22	0.05	0.20	QP
7	0.24293	29.07	-22.92	52.00	28.83	0.04	0.20	AVERAGE
8	0.24293	43.62	-18.37	62.00	43.38	0.04	0.20	QP
9	0.31608	44.01	-15.80	59.81	43.77	0.04	0.20	QP
10	0.31608	41.37	-8.44	49.81	41.13	0.04	0.20	AVERAGE
11	0.43052	30.37	-16.97	47.24	30.14	0.03	0.20	AVERAGE
12	0.43052	44.70	-12.54	57.24	44.47	0.03	0.20	QP
13	0.44916	42.77	-14.12	56.89	42.54	0.03	0.20	QP
14	0.44916	27.52	-19.37	46.89	27.29	0.03	0.20	AVERAGE
15	0.49411	22.85	-23.25	46.10	22.64	0.03	0.18	AVERAGE
16	0.49411	42.40	-13.70	56.10	42.19	0.03	0.18	QP
17	0.59794	40.35	-15.65	56.00	40.12	0.03	0.20	QP
18	0.59794	35.02	-10.98	46.00	34.79	0.03	0.20	AVERAGE
19	0.63048	34.77	-11.23	46.00	34.54	0.03	0.20	AVERAGE
20	0.63048	42.99	-13.01	56.00	42.76	0.03	0.20	QP

Temperature	24°C	Humidity	56%
Test Engineer	Peter Wu	Phase	Neutral
Configuration	Normal Link / Antenna 2		

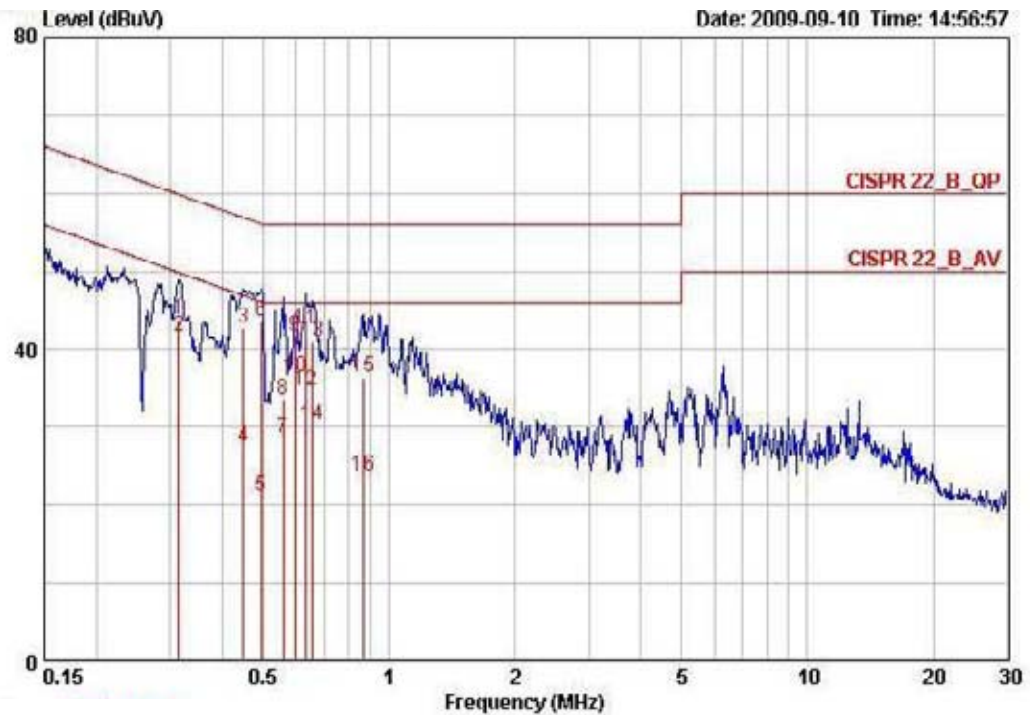

	Freq	Level	Over	Limit	Read	LISN	Cable	Remark
	MHz	dBuV	Limit	Line	Level	Factor	Loss	
			dB	dBuV	dBuV	dB	dB	
1	0.31495	43.86	-15.98	59.84	43.59	0.07	0.20	QP
2	0.31495	41.71	-8.13	49.84	41.44	0.07	0.20	AVERAGE
3	0.44916	42.79	-14.10	56.89	42.52	0.07	0.20	QP
4	0.44916	27.51	-19.30	46.09	27.24	0.07	0.20	AVERAGE
5	0.49411	21.10	-25.00	46.10	20.85	0.07	0.18	AVERAGE
6	0.49411	43.68	-12.42	56.10	43.43	0.07	0.18	QP
7	0.55815	28.60	-17.40	46.00	28.33	0.07	0.20	AVERAGE
8	0.55815	33.48	-22.52	56.00	33.21	0.07	0.20	QP
9	0.59695	41.53	-14.47	56.00	41.26	0.07	0.20	QP
10	0.59695	36.39	-9.61	46.00	36.12	0.07	0.20	AVERAGE
11	0.63048	42.53	-13.47	56.00	42.26	0.07	0.20	QP
12	0.63048	34.61	-11.39	46.00	34.34	0.07	0.20	AVERAGE
13	0.65778	40.90	-15.10	56.00	40.63	0.07	0.20	QP
14	0.65778	30.32	-15.60	46.00	30.05	0.07	0.20	AVERAGE
15	0.86643	36.51	-19.49	56.00	36.24	0.07	0.20	QP
16	0.86643	23.77	-22.23	46.00	23.50	0.07	0.20	AVERAGE

Note: Level = Read Level + LISN Factor + Cable Loss

<For Antenna 3>:

Temperature	24°C	Humidity	56%
Test Engineer	Peter Wu	Phase	Line
Configuration	Normal Link / Antenna 3		

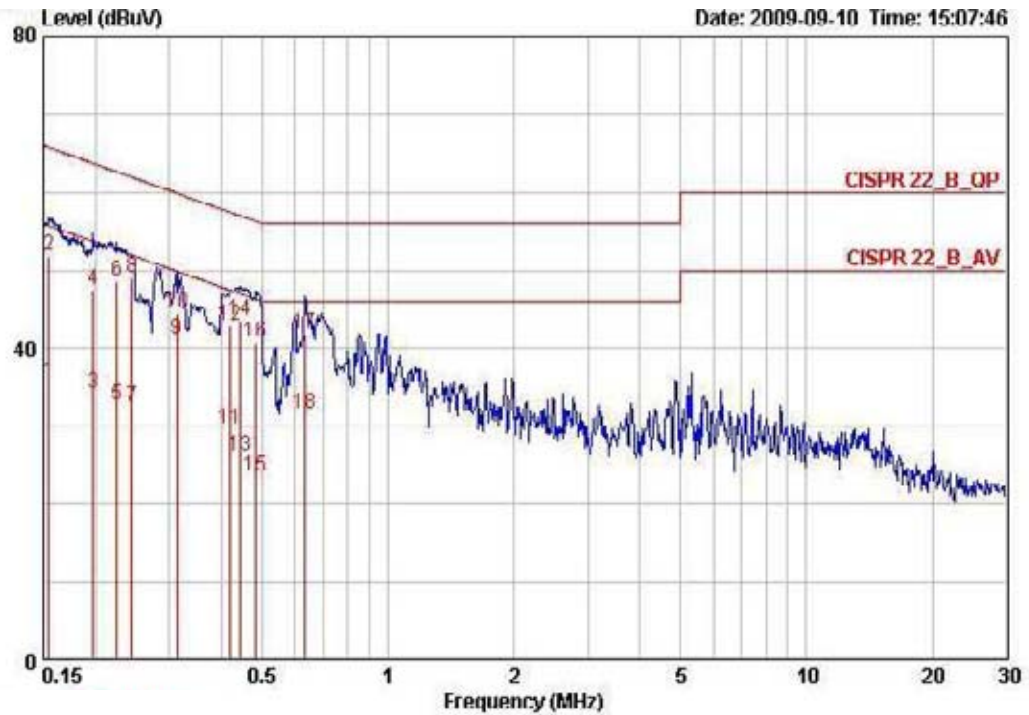

	Freq	Level	Over Limit	Limit Line	Read Level	LISN Factor	Cable Loss	Remark
	MHz	dBuV	dB	dBuV	dBuV	dB	dB	
1	0.15485	35.72	-20.01	55.74	35.45	0.07	0.20	AVERAGE
2	0.15485	51.81	-13.92	65.74	51.54	0.07	0.20	QP
3	0.19758	34.14	-19.57	53.71	33.89	0.05	0.20	AVERAGE
4	0.19758	47.43	-16.28	63.71	47.18	0.05	0.20	QP
5	0.22437	32.64	-20.02	52.66	32.39	0.05	0.20	AVERAGE
6	0.22437	48.64	-14.02	62.66	48.39	0.05	0.20	QP
7	0.24422	32.45	-19.50	51.95	32.21	0.04	0.20	AVERAGE
8	0.24422	48.98	-12.97	61.95	48.74	0.04	0.20	QP
9	0.31328	41.31	-8.58	49.88	41.07	0.04	0.20	AVERAGE
10	0.31328	44.45	-15.44	59.88	44.21	0.04	0.20	QP
11	0.41927	29.69	-17.77	47.46	29.46	0.03	0.20	AVERAGE
12	0.41927	42.95	-14.51	57.46	42.72	0.03	0.20	QP
13	0.44208	26.14	-20.88	47.02	25.91	0.03	0.20	AVERAGE
14	0.44208	43.62	-13.40	57.02	43.39	0.03	0.20	QP
15	0.48375	23.49	-22.78	46.27	23.36	0.03	0.10	AVERAGE
16	0.48375	40.68	-15.59	56.27	40.55	0.03	0.10	QP
17	0.63383	41.89	-14.11	56.00	41.66	0.03	0.20	QP
18	0.63383	31.58	-14.42	46.00	31.35	0.03	0.20	AVERAGE

Temperature	24°C	Humidity	56%
Test Engineer	Peter Wu	Phase	Neutral
Configuration	Normal Link / Antenna 3		

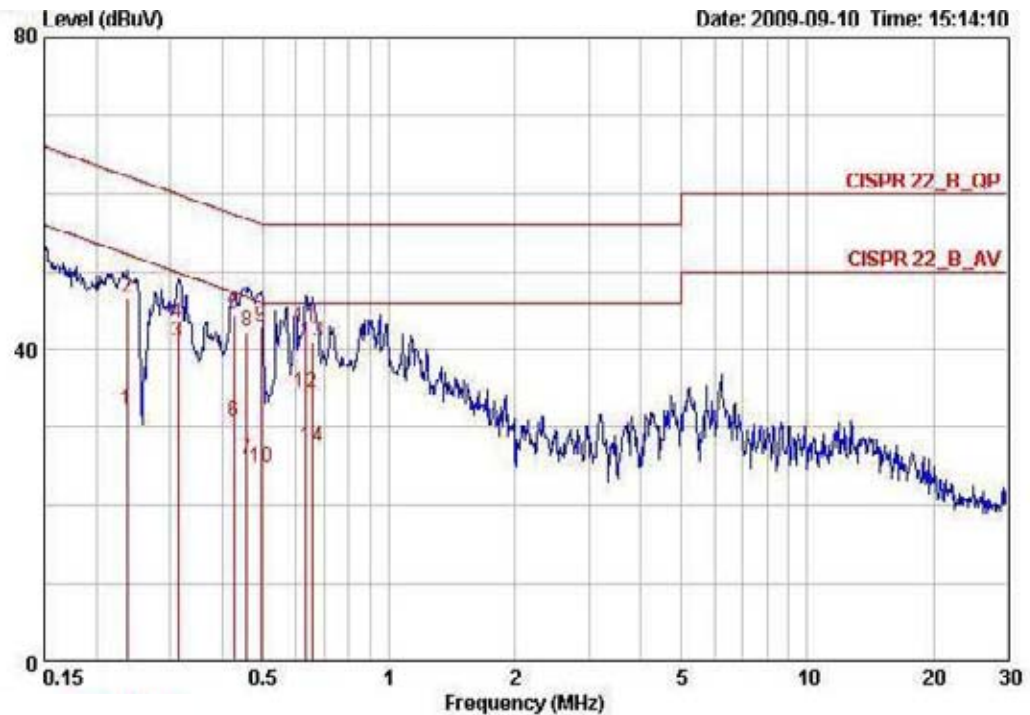

	Freq	Level	Over	Limit	Read	LISN	Cable	Remark
	MHz	dBuV	Limit	Line	Level	Factor	Loss	
			dB	dBuV	dBuV	dB	dB	
1	0.23658	32.26	-19.96	52.22	31.98	0.08	0.20	AVERAGE
2	0.23658	46.62	-15.60	62.22	46.34	0.08	0.20	QP
3	0.31328	41.08	-8.80	49.88	40.81	0.07	0.20	AVERAGE
4	0.31328	43.30	-16.58	59.88	43.03	0.07	0.20	QP
5	0.42599	44.55	-12.78	57.33	44.28	0.07	0.20	QP
6	0.42599	30.74	-16.59	47.33	30.47	0.07	0.20	AVERAGE
7	0.45636	25.88	-20.88	46.76	25.61	0.07	0.20	AVERAGE
8	0.45636	42.23	-14.53	56.76	41.96	0.07	0.20	QP
9	0.49411	43.00	-13.10	56.10	42.75	0.07	0.18	QP
10	0.49411	24.82	-21.28	46.10	24.57	0.07	0.18	AVERAGE
11	0.63383	42.79	-13.21	56.00	42.52	0.07	0.20	QP
12	0.63383	34.48	-11.52	46.00	34.21	0.07	0.20	AVERAGE
13	0.65430	41.00	-15.00	56.00	40.73	0.07	0.20	QP
14	0.65430	27.57	-18.43	46.00	27.30	0.07	0.20	AVERAGE

Note: Level = Read Level + LISN Factor + Cable Loss

<For Antenna 4>:

Temperature	24°C	Humidity	56%
Test Engineer	Peter Wu	Phase	Line
Configuration	Normal Link / Antenna 4		

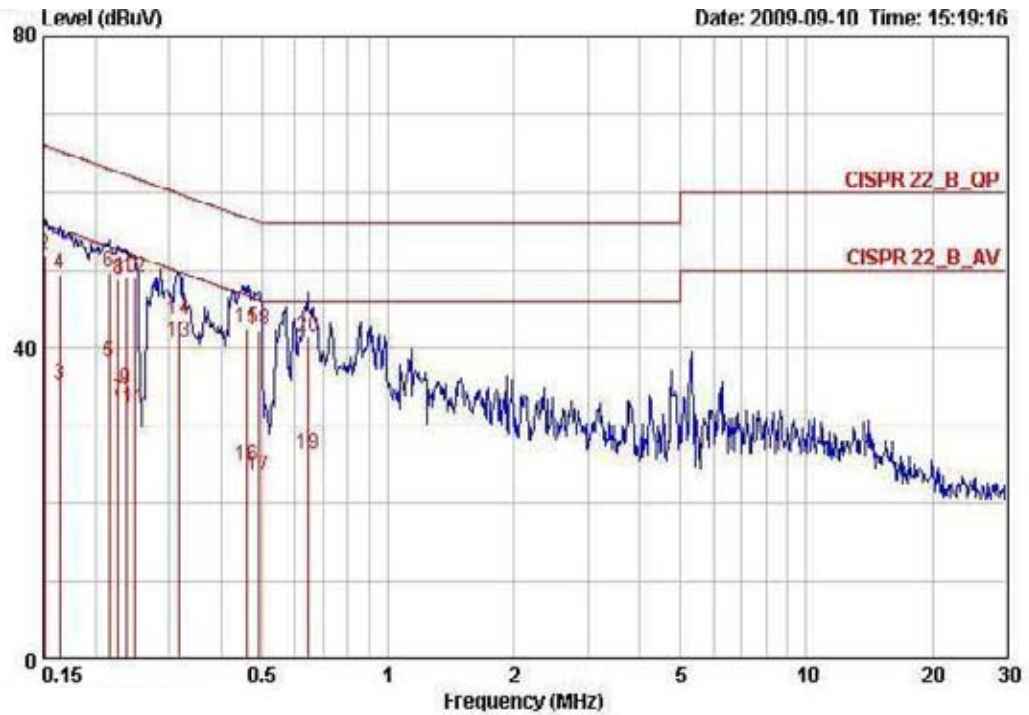

	Freq	Level	Over Limit	Limit Line	Read Level	LISN Factor	Cable Loss	Remark
	MHz	dBuV	dB	dBuV	dBuV	dB	dB	
1	0.15080	36.90	-19.05	55.96	36.63	0.07	0.20	AVERAGE
2	0.15080	51.87	-14.08	65.96	51.60	0.07	0.20	QP
3	0.16414	35.34	-19.91	55.25	35.07	0.07	0.20	AVERAGE
4	0.16414	49.54	-15.71	65.25	49.27	0.07	0.20	QP
5	0.21506	38.05	-14.96	53.01	37.80	0.05	0.20	AVERAGE
6	0.21506	49.71	-13.30	63.01	49.46	0.05	0.20	QP
7	0.22676	33.30	-19.27	52.57	33.05	0.05	0.20	AVERAGE
8	0.22676	48.80	-13.77	62.57	48.55	0.05	0.20	QP
9	0.23658	34.68	-17.54	52.22	34.43	0.05	0.20	AVERAGE
10	0.23658	48.97	-13.25	62.22	48.72	0.05	0.20	QP
11	0.24914	32.18	-19.64	51.82	31.94	0.04	0.20	AVERAGE
12	0.24814	49.00	-12.82	61.82	48.76	0.04	0.20	QP
13	0.31662	40.72	-9.08	49.80	40.48	0.04	0.20	AVERAGE
14	0.31662	43.53	-16.27	59.80	43.29	0.04	0.20	QP
15	0.45878	42.53	-14.18	56.71	42.30	0.03	0.20	QP
16	0.45878	24.77	-21.94	46.71	24.54	0.03	0.20	AVERAGE
17	0.49150	23.60	-22.55	46.14	23.44	0.03	0.13	AVERAGE
18	0.49150	42.37	-13.78	56.14	42.21	0.03	0.13	QP
19	0.64398	26.37	-19.63	46.00	26.14	0.03	0.20	AVERAGE
20	0.64398	41.52	-14.48	56.00	41.29	0.03	0.20	QP



Temperature	24°C	Humidity	56%
Test Engineer	Peter Wu	Phase	Neutral
Configuration	Normal Link / Antenna 4		

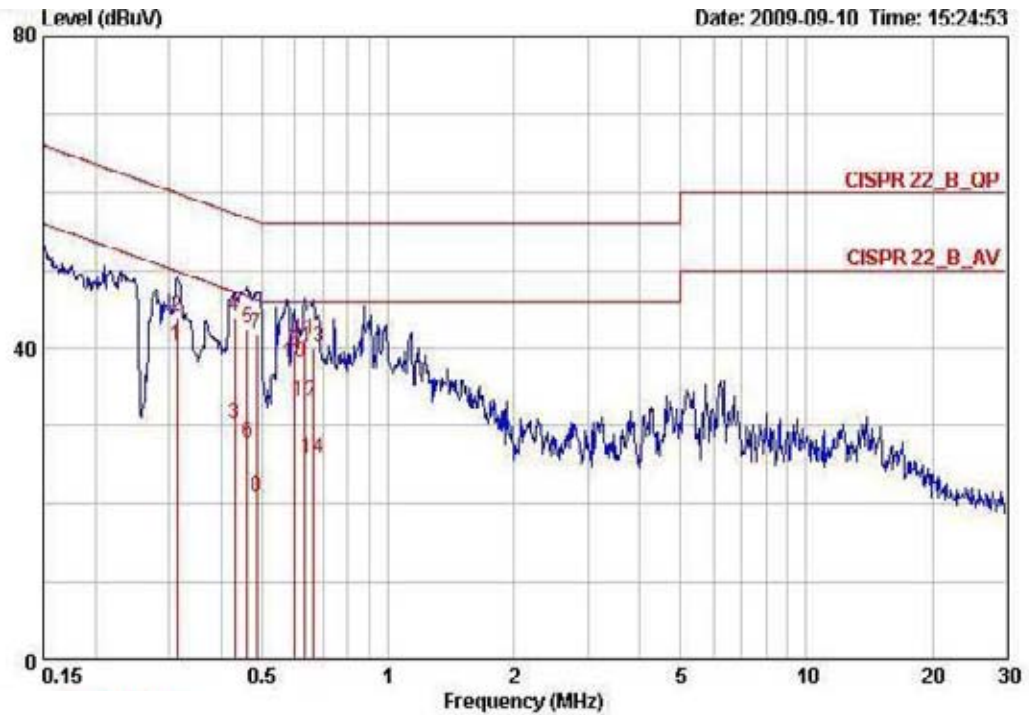

	Freq	Level	Over	Limit	Read	LISN	Cable	Remark
	MHz	dBuV	Limit	Line	Level	Factor	Loss	
			dB	dBuV	dBuV	dB	dB	
1	0.31328	40.41	-9.47	49.88	40.14	0.07	0.20	AVERAGE
2	0.31328	44.06	-15.82	59.88	43.79	0.07	0.20	QP
3	0.43052	30.25	-16.99	47.24	29.98	0.07	0.20	AVERAGE
4	0.43052	44.02	-13.22	57.24	43.75	0.07	0.20	QP
5	0.46122	42.41	-14.26	56.67	42.14	0.07	0.20	QP
6	0.46122	27.89	-18.78	46.67	27.62	0.07	0.20	AVERAGE
7	0.48632	41.77	-14.46	56.23	41.59	0.07	0.11	QP
8	0.48632	20.93	-25.30	46.23	20.75	0.07	0.11	AVERAGE
9	0.59553	39.75	-16.25	56.00	39.48	0.07	0.20	QP
10	0.59553	38.16	-7.84	46.00	37.89	0.07	0.20	AVERAGE
11	0.63383	41.11	-14.89	56.00	40.84	0.07	0.20	QP
12	0.63383	33.13	-12.97	46.00	32.86	0.07	0.20	AVERAGE
13	0.66478	40.20	-15.80	56.00	39.93	0.07	0.20	QP
14	0.66478	25.84	-20.16	46.00	25.57	0.07	0.20	AVERAGE

Note: Level = Read Level + LISN Factor + Cable Loss

<For Antenna 5>:

Temperature	24°C	Humidity	56%
Test Engineer	Peter Wu	Phase	Line
Configuration	Normal Link / Antenna 5		

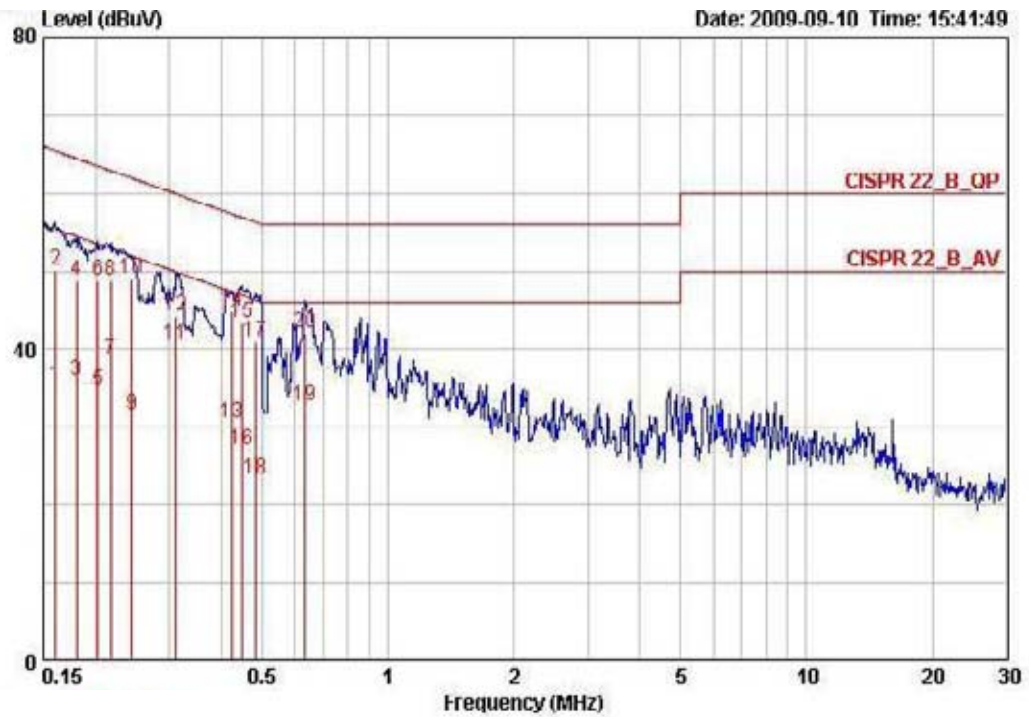

	Freq	Level	Over Limit	Limit Line	Read Level	LISN Factor	Cable Loss	Remark
	MHz	dBrV	dB	dBrV	dBrV	dB	dB	
1	0.16070	35.22	-20.21	55.43	34.95	0.07	0.20	AVERAGE
2	0.16070	50.04	-15.39	65.43	49.77	0.07	0.20	QP
3	0.10056	36.05	-10.41	54.46	35.79	0.06	0.20	AVERAGE
4	0.18056	48.90	-15.56	64.46	48.64	0.06	0.20	QP
5	0.20289	34.63	-18.86	53.49	34.38	0.05	0.20	AVERAGE
6	0.20289	48.91	-14.58	63.49	48.66	0.05	0.20	QP
7	0.21735	38.67	-14.25	52.92	38.42	0.05	0.20	AVERAGE
8	0.21735	40.01	-14.11	62.92	40.56	0.05	0.20	QP
9	0.24422	31.57	-20.38	51.95	31.33	0.04	0.20	AVERAGE
10	0.24422	49.06	-12.89	61.95	48.82	0.04	0.20	QP
11	0.31163	40.45	-9.48	49.93	40.21	0.04	0.20	AVERAGE
12	0.31163	44.31	-15.62	59.93	44.07	0.04	0.20	QP
13	0.42150	30.49	-16.93	47.42	30.26	0.03	0.20	AVERAGE
14	0.42150	44.95	-12.47	57.42	44.72	0.03	0.20	QP
15	0.44679	43.36	-13.57	56.93	43.13	0.03	0.20	QP
16	0.44679	27.12	-19.81	46.93	26.89	0.03	0.20	AVERAGE
17	0.48119	41.05	-15.27	56.32	40.92	0.03	0.10	QP
18	0.48119	23.42	-22.90	46.32	23.29	0.03	0.10	AVERAGE
19	0.63048	32.67	-13.33	46.00	32.44	0.03	0.20	AVERAGE
20	0.63048	42.17	-13.83	56.00	41.94	0.03	0.20	QP

Temperature	24°C	Humidity	56%
Test Engineer	Peter Wu	Phase	Neutral
Configuration	Normal Link / Antenna 5		

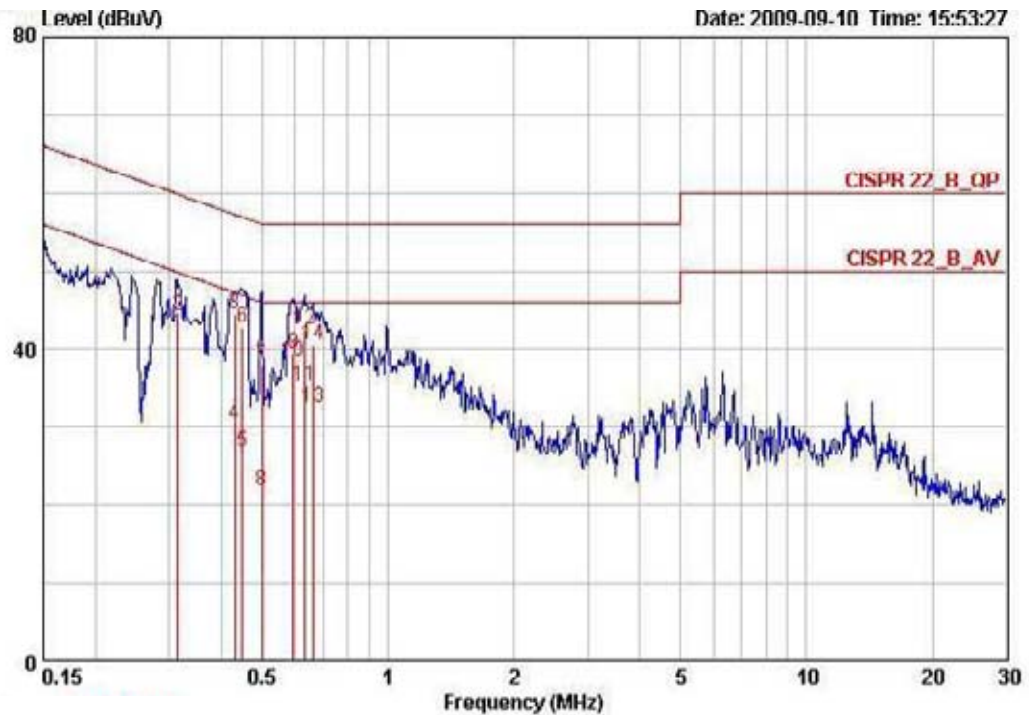

	Freq	Level	Over	Limit	Read	LISN	Cable	Remark
	MHz	dBuV	Limit	Line	Level	Factor	Loss	
			dB	dBuV	dBuV	dB	dB	
1	0.31523	41.95	-7.88	49.83	41.68	0.07	0.20	AVERAGE
2	0.31523	44.16	-15.67	59.83	43.89	0.07	0.20	QP
3	0.43052	44.38	-12.86	57.24	44.11	0.07	0.20	QP
4	0.43052	30.30	-16.94	47.24	30.03	0.07	0.20	AVERAGE
5	0.44916	26.73	-20.16	46.89	26.46	0.07	0.20	AVERAGE
6	0.44916	42.77	-14.12	56.89	42.50	0.07	0.20	QP
7	0.49937	37.87	-18.14	56.01	37.62	0.07	0.18	QP
8	0.49937	21.79	-24.22	46.01	21.54	0.07	0.18	AVERAGE
9	0.59478	39.54	-16.46	56.00	39.27	0.07	0.20	QP
10	0.59478	38.26	-7.74	46.00	37.99	0.07	0.20	AVERAGE
11	0.63048	35.39	-10.61	46.00	35.12	0.07	0.20	AVERAGE
12	0.63048	42.61	-13.39	56.00	42.34	0.07	0.20	QP
13	0.66127	32.44	-13.56	46.00	32.17	0.07	0.20	AVERAGE
14	0.66127	40.44	-15.56	56.00	40.17	0.07	0.20	QP

Note: Level = Read Level + LISN Factor + Cable Loss

<For Antenna 6>:

Temperature	24°C	Humidity	56%
Test Engineer	Peter Wu	Phase	Line
Configuration	Normal Link / Antenna 6		

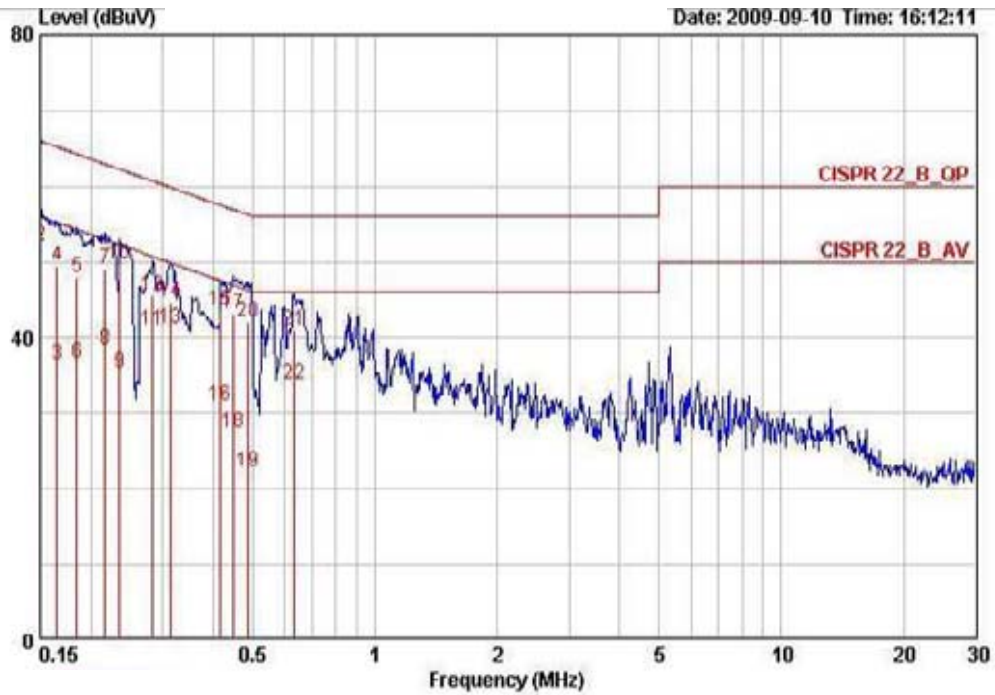

	Freq	Level	Over	Limit	Read	LISN	Cable	Remark
	MHz	dBuV	Limit	Line	Level	Factor	Loss	
			dB	dBuV	dBuV	dB	dB	
1	0.15000	37.32	-18.68	56.00	37.04	0.08	0.20	AVERAGE
2	0.15000	52.11	-13.89	66.00	51.83	0.08	0.20	QP
3	0.16501	36.40	-18.81	55.21	36.13	0.07	0.20	AVERAGE
4	0.16501	49.43	-15.78	65.21	49.16	0.07	0.20	QP
5	0.18443	47.86	-16.43	64.28	47.60	0.06	0.20	QP
6	0.18443	36.65	-17.64	54.28	36.39	0.06	0.20	AVERAGE
7	0.21620	49.13	-13.84	62.96	48.88	0.05	0.20	QP
8	0.21620	38.37	-14.60	52.96	38.12	0.05	0.20	AVERAGE
9	0.23533	35.21	-17.05	52.26	34.96	0.05	0.20	AVERAGE
10	0.23533	49.61	-12.65	62.26	49.36	0.05	0.20	QP
11	0.28328	40.89	-9.83	50.72	40.65	0.04	0.20	AVERAGE
12	0.28328	45.46	-15.26	60.72	45.22	0.04	0.20	QP
13	0.31495	41.18	-8.66	49.84	40.94	0.04	0.20	AVERAGE
14	0.31495	44.77	-15.07	59.84	44.53	0.04	0.20	QP
15	0.41705	43.49	-14.02	57.51	43.26	0.03	0.20	QP
16	0.41705	30.90	-16.61	47.51	30.67	0.03	0.20	AVERAGE
17	0.44916	43.09	-13.80	56.89	42.86	0.03	0.20	QP
18	0.44916	27.41	-19.48	46.89	27.18	0.03	0.20	AVERAGE
19	0.48632	22.13	-24.10	46.23	21.99	0.03	0.11	AVERAGE
20	0.48632	42.07	-14.16	56.23	41.93	0.03	0.11	QP
21	0.63383	40.99	-15.01	56.00	40.76	0.03	0.20	QP
22	0.63383	33.79	-12.21	46.00	33.56	0.03	0.20	AVERAGE

Temperature	24°C	Humidity	56%
Test Engineer	Peter Wu	Phase	Neutral
Configuration	Normal Link / Antenna 6		

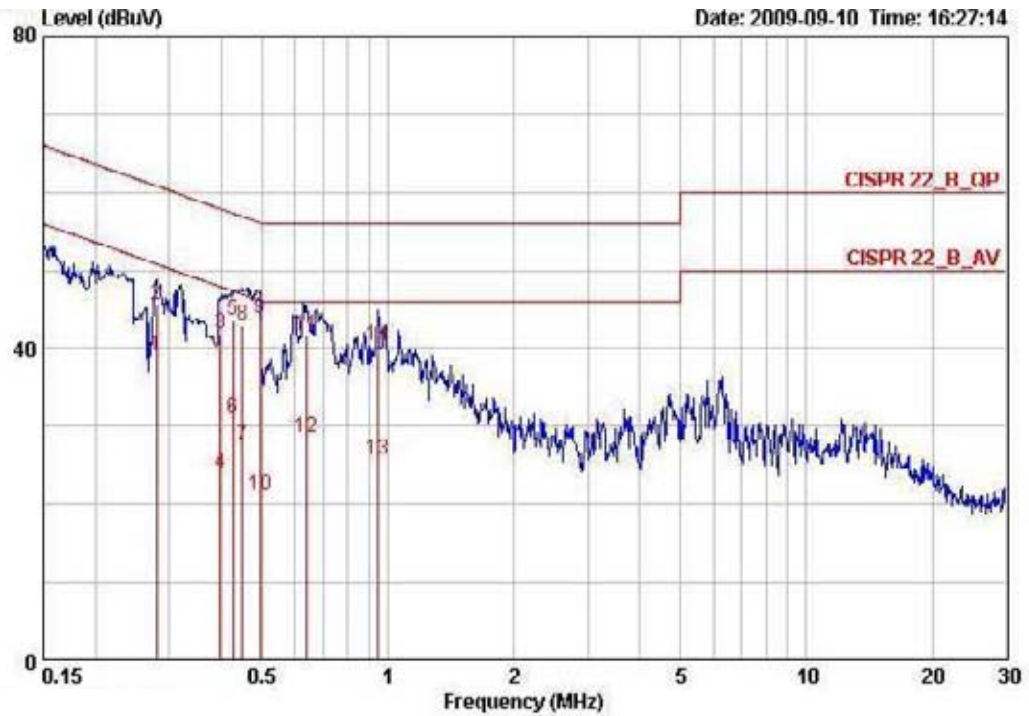

	Freq	Level	Over	Limit	Read	LISN	Cable	Remark
	MHz	dBuV	Limit	Line	Level	Factor	Loss	
			dB	dBuV	dBuV	dB	dB	
1	0.28029	39.01	-11.80	50.81	38.73	0.08	0.20	AVERAGE
2	0.28029	45.46	-15.35	60.81	45.18	0.08	0.20	QP
3	0.39763	41.80	-16.10	57.90	41.53	0.07	0.20	QP
4	0.39763	24.08	-23.82	47.90	23.81	0.07	0.20	AVERAGE
5	0.42599	43.57	-13.76	57.33	43.30	0.07	0.20	QP
6	0.42599	30.88	-16.45	47.33	30.61	0.07	0.20	AVERAGE
7	0.44916	27.56	-19.33	46.89	27.29	0.07	0.20	AVERAGE
8	0.44916	42.95	-13.94	56.89	42.68	0.07	0.20	QP
9	0.49411	43.76	-12.34	56.10	43.51	0.07	0.18	QP
10	0.49411	21.20	-24.90	46.10	20.95	0.07	0.18	AVERAGE
11	0.63733	41.67	-14.33	56.00	41.40	0.07	0.20	QP
12	0.63733	28.65	-17.35	46.00	28.38	0.07	0.20	AVERAGE
13	0.94809	25.69	-20.31	46.00	25.42	0.07	0.20	AVERAGE
14	0.94809	40.25	-15.75	56.00	39.98	0.07	0.20	QP

Note: Level = Read Level + LISN Factor + Cable Loss

## 4.2. 99% Occupied Bandwidth Measurement

### 4.2.1. Limit

No restriction limits. But resolution bandwidth within band edge measurement is 1% of the 99% occupied bandwidth.

### 4.2.2. Measuring Instruments and Setting

Please refer to section 5 of equipments list in this report. The following table is the setting of the spectrum analyzer.

Spectrum Parameters	Setting
Attenuation	Auto
Span Frequency	> 26dB Bandwidth
RB	300 kHz
VB	1000 kHz
Detector	Peak
Trace	Max Hold
Sweep Time	Auto

### 4.2.3. Test Procedures

1. The transmitter output (antenna port) was connected to the spectrum analyzer in peak hold mode.
2. The resolution bandwidth of 300 kHz and the video bandwidth of 1000 kHz were used.
3. Measured the spectrum width with power higher than 26dB below carrier.
4. Measuring multiple antennas, the connector is required to link with spectrum analyzer through a combiner.

### 4.2.4. Test Setup Layout

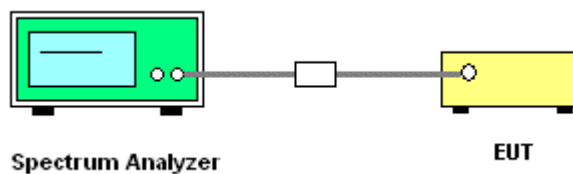

### 4.2.5. Test Deviation

There is no deviation with the original standard.

### 4.2.6. EUT Operation during Test

The EUT was programmed to be in continuously transmitting mode.

#### 4.2.7. Test Result of 99% Occupied Bandwidth

<For Antenna 1>:

<b>Temperature</b>	21°C	<b>Humidity</b>	56%
<b>Test Engineer</b>	Johnson Chang	<b>Configurations</b>	802.11n / Antenna 1

##### Configuration 802.11n MCS8 20MHz Ant. 1-1 + Ant. 1-3

Channel	Frequency	26dB Bandwidth (MHz)	99% Occupied Bandwidth (MHz)
52	5260 MHz	24.32	18.24
60	5300 MHz	24.64	18.24
64	5320 MHz	24.16	18.08
100	5500 MHz	24.16	17.92
116	5580 MHz	24.00	18.24
140	5700 MHz	23.36	18.08

##### Configuration 802.11n MCS8 40MHz Ant. 1-1 + Ant. 1-3

Channel	Frequency	26dB Bandwidth (MHz)	99% Occupied Bandwidth (MHz)
54	5270 MHz	69.12	36.80
62	5310 MHz	46.56	36.48
102	5510MHz	44.96	36.48
110	5550 MHz	50.40	36.80
134	5670 MHz	45.28	36.64



<b>Temperature</b>	21°C	<b>Humidity</b>	56%
<b>Test Engineer</b>	Johnson Chang	<b>Configurations</b>	802.11a / Antenna 1

**Configuration IEEE 802.11a Ant. 1-1 + Ant. 1-3**

<b>Channel</b>	<b>Frequency</b>	<b>26dB Bandwidth (MHz)</b>	<b>99% Occupied Bandwidth (MHz)</b>
52	5260 MHz	27.04	17.44
60	5300 MHz	26.56	17.44
64	5320 MHz	21.60	16.96
100	5500 MHz	22.56	17.12
116	5580 MHz	24.80	17.44
140	5700 MHz	21.76	16.48



<For Antenna 2>:

<b>Temperature</b>	21°C	<b>Humidity</b>	56%
<b>Test Engineer</b>	Johnson Chang	<b>Configurations</b>	802.11n / Antenna 2

Configuration 802.11n MCS8 20MHz Ant. 2-1 + Ant. 2-3

Channel	Frequency	26dB Bandwidth (MHz)	99% Occupied Bandwidth (MHz)
52	5260 MHz	27.36	18.40
60	5300 MHz	23.68	18.08
64	5320 MHz	24.00	18.08
100	5500 MHz	26.40	18.24
116	5580 MHz	24.80	18.24
140	5700 MHz	22.88	18.08

Configuration 802.11n MCS8 40MHz Ant. 2-1 + Ant. 2-3

Channel	Frequency	26dB Bandwidth (MHz)	99% Occupied Bandwidth (MHz)
54	5270 MHz	75.68	37.44
62	5310 MHz	44.80	36.48
102	5510MHz	43.20	36.48
110	5550 MHz	69.60	36.64
134	5670 MHz	60.32	36.64



<b>Temperature</b>	21°C	<b>Humidity</b>	56%
<b>Test Engineer</b>	Johnson Chang	<b>Configurations</b>	802.11a / Antenna 2

**Configuration IEEE 802.11a Ant. 2-1 + Ant. 2-3**

<b>Channel</b>	<b>Frequency</b>	<b>26dB Bandwidth (MHz)</b>	<b>99% Occupied Bandwidth (MHz)</b>
52	5260 MHz	30.72	17.92
60	5300 MHz	22.08	16.96
64	5320 MHz	21.60	16.96
100	5500 MHz	25.44	17.28
116	5580 MHz	24.80	17.44
140	5700 MHz	22.40	16.64

<For Antenna 3>:

<b>Temperature</b>	21°C	<b>Humidity</b>	56%
<b>Test Engineer</b>	Johnson Chang	<b>Configurations</b>	802.11n / Antenna 3

Configuration 802.11n MCS8 20MHz Ant. 3-1 + Ant. 3-3

Channel	Frequency	26dB Bandwidth (MHz)	99% Occupied Bandwidth (MHz)
52	5260 MHz	27.36	18.40
60	5300 MHz	29.28	18.56
64	5320 MHz	24.00	18.08
100	5500 MHz	24.00	17.92
116	5580 MHz	24.80	18.24
140	5700 MHz	23.04	18.08

Configuration 802.11n MCS8 40MHz Ant. 3-1 + Ant. 3-3

Channel	Frequency	26dB Bandwidth (MHz)	99% Occupied Bandwidth (MHz)
54	5270 MHz	75.68	37.44
62	5310 MHz	44.64	36.48
102	5510MHz	43.68	36.48
110	5550 MHz	69.60	36.64
134	5670 MHz	44.00	36.48



<b>Temperature</b>	21°C	<b>Humidity</b>	56%
<b>Test Engineer</b>	Johnson Chang	<b>Configurations</b>	802.11a / Antenna 3

**Configuration IEEE 802.11a Ant. 3-1 + Ant. 3-3**

<b>Channel</b>	<b>Frequency</b>	<b>26dB Bandwidth (MHz)</b>	<b>99% Occupied Bandwidth (MHz)</b>
52	5260 MHz	30.72	17.29
60	5300 MHz	30.08	17.76
64	5320 MHz	26.24	17.28
100	5500 MHz	23.04	17.12
116	5580 MHz	24.80	17.44
140	5700 MHz	24.00	17.12

<For Antenna 4>:

<b>Temperature</b>	21°C	<b>Humidity</b>	56%
<b>Test Engineer</b>	Johnson Chang	<b>Configurations</b>	802.11n / Antenna 4

Configuration 802.11n MCS8 20MHz Ant. 4-1 + Ant. 4-3

Channel	Frequency	26dB Bandwidth (MHz)	99% Occupied Bandwidth (MHz)
52	5260 MHz	27.36	18.40
60	5300 MHz	29.28	18.56
64	5320 MHz	24.00	18.08
100	5500 MHz	22.88	17.92
116	5580 MHz	24.80	18.24
140	5700 MHz	23.36	18.08

Configuration 802.11n MCS8 40MHz Ant. 4-1 + Ant. 4-3

Channel	Frequency	26dB Bandwidth (MHz)	99% Occupied Bandwidth (MHz)
54	5270 MHz	69.60	36.80
62	5310 MHz	43.84	36.48
102	5510MHz	44.32	36.48
110	5550 MHz	44.80	36.64
134	5670 MHz	45.28	36.64



<b>Temperature</b>	21°C	<b>Humidity</b>	56%
<b>Test Engineer</b>	Johnson Chang	<b>Configurations</b>	802.11a / Antenna 4

**Configuration IEEE 802.11a Ant. 4-1 + Ant. 4-3**

<b>Channel</b>	<b>Frequency</b>	<b>26dB Bandwidth (MHz)</b>	<b>99% Occupied Bandwidth (MHz)</b>
52	5260 MHz	30.72	17.92
60	5300 MHz	30.08	17.76
64	5320 MHz	22.56	17.12
100	5500 MHz	22.88	17.12
116	5580 MHz	24.80	17.44
140	5700 MHz	23.68	17.28

<For Antenna 5>:

<b>Temperature</b>	21°C	<b>Humidity</b>	56%
<b>Test Engineer</b>	Johnson Chang	<b>Configurations</b>	802.11n / Antenna 5

Configuration 802.11n MCS8 20MHz Ant. 5-1 + Ant. 5-3

Channel	Frequency	26dB Bandwidth (MHz)	99% Occupied Bandwidth (MHz)
52	5260 MHz	27.36	18.40
60	5300 MHz	29.28	18.56
64	5320 MHz	24.16	18.08
100	5500 MHz	24.00	17.92
116	5580 MHz	24.80	18.24
140	5700 MHz	23.52	17.92

Configuration 802.11n MCS8 40MHz Ant. 5-1 + Ant. 5-3

Channel	Frequency	26dB Bandwidth (MHz)	99% Occupied Bandwidth (MHz)
54	5270 MHz	75.68	37.44
62	5310 MHz	43.52	36.48
102	5510MHz	44.96	36.48
110	5550 MHz	44.80	36.64
134	5670 MHz	44.32	36.64



<b>Temperature</b>	21°C	<b>Humidity</b>	56%
<b>Test Engineer</b>	Johnson Chang	<b>Configurations</b>	802.11a / Antenna 5

**Configuration IEEE 802.11a Ant. 5-1 + Ant. 5-3**

<b>Channel</b>	<b>Frequency</b>	<b>26dB Bandwidth (MHz)</b>	<b>99% Occupied Bandwidth (MHz)</b>
52	5260 MHz	30.72	17.92
60	5300 MHz	30.08	17.76
64	5320 MHz	22.56	17.12
100	5500 MHz	22.88	17.12
116	5580 MHz	24.80	17.44
140	5700 MHz	22.24	16.48



<For Antenna 6>:

<b>Temperature</b>	21°C	<b>Humidity</b>	56%
<b>Test Engineer</b>	Johnson Chang	<b>Configurations</b>	802.11n / Antenna 6

Configuration 802.11n MCS8 20MHz Ant. 6-1 + Ant. 6-3

Channel	Frequency	26dB Bandwidth (MHz)	99% Occupied Bandwidth (MHz)
52	5260 MHz	24.32	18.24
60	5300 MHz	27.52	18.24
64	5320 MHz	23.52	17.92
100	5500 MHz	24.00	17.92
116	5580 MHz	24.00	18.24
140	5700 MHz	23.36	18.08

Configuration 802.11n MCS8 40MHz Ant. 6-1 + Ant. 6-3

Channel	Frequency	26dB Bandwidth (MHz)	99% Occupied Bandwidth (MHz)
54	5270 MHz	69.60	36.80
62	5310 MHz	43.84	36.48
102	5510MHz	45.44	36.48
110	5550 MHz	44.48	36.64
134	5670 MHz	45.44	36.64



<b>Temperature</b>	21°C	<b>Humidity</b>	56%
<b>Test Engineer</b>	Johnson Chang	<b>Configurations</b>	802.11a / Antenna 6

**Configuration IEEE 802.11a Ant. 6-1 + Ant. 6-3**

<b>Channel</b>	<b>Frequency</b>	<b>26dB Bandwidth (MHz)</b>	<b>99% Occupied Bandwidth (MHz)</b>
52	5260 MHz	27.04	17.44
60	5300 MHz	26.56	17.44
64	5320 MHz	22.08	16.96
100	5500 MHz	22.88	17.12
116	5580 MHz	24.80	17.44
140	5700 MHz	22.24	16.48

<For Antenna 1>:

26 dB Bandwidth Plot on Configuration 802.11n MCS8 20MHz Ant. 1-1 + Ant. 1-3 / 5260 MHz

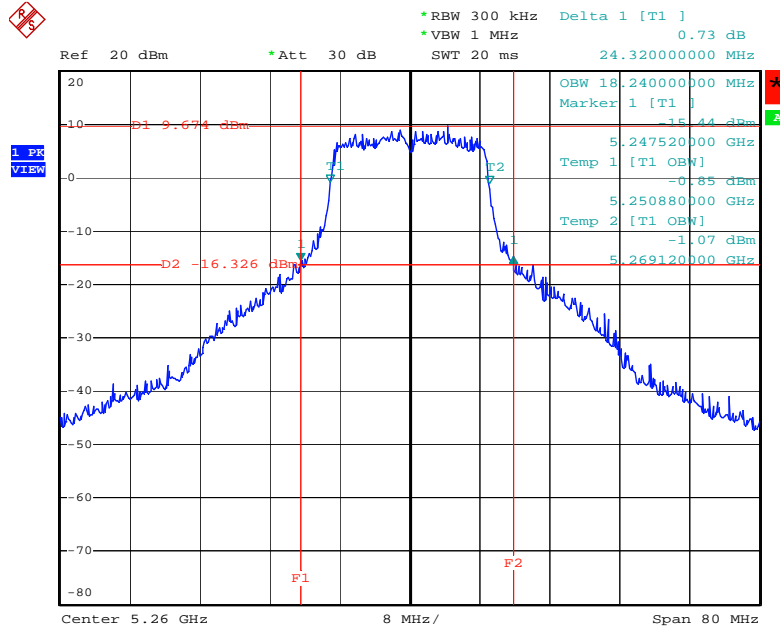

Date: 16.SEP.2009 18:23:36

26 dB Bandwidth Plot on Configuration 802.11n MCS8 20MHz Ant. 1-1 + Ant. 1-3 / 5300 MHz

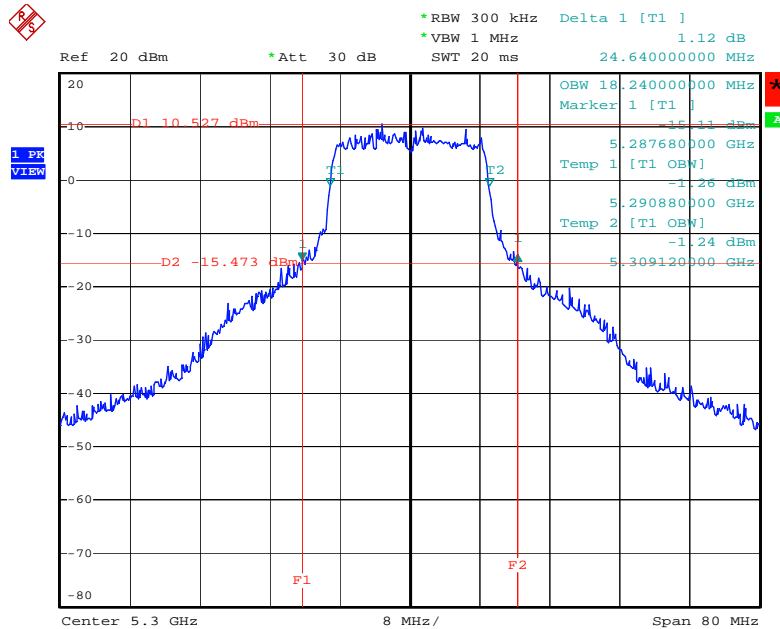

Date: 16.SEP.2009 18:26:02

26 dB Bandwidth Plot on Configuration 802.11n MCS8 20MHz Ant. 1-1 + Ant. 1-3 / 5320 MHz

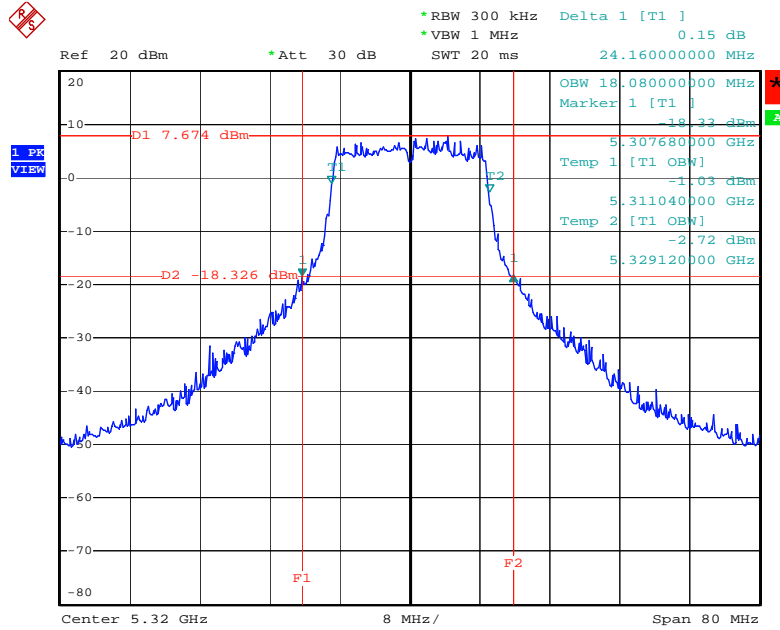

Date: 16.SEP.2009 18:29:46

26 dB Bandwidth Plot on Configuration 802.11n MCS8 20MHz Ant. 1-1 + Ant. 1-3 / 5500 MHz

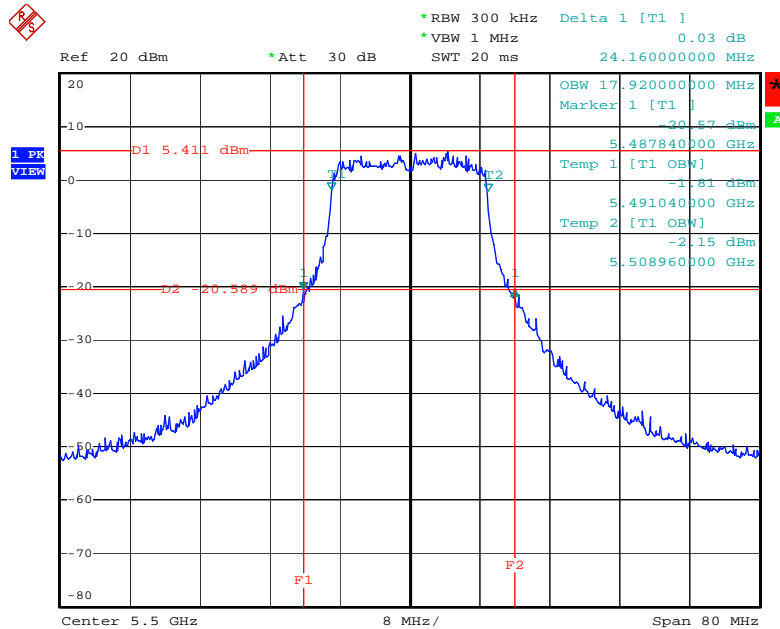

Date: 16.SEP.2009 18:33:29

26 dB Bandwidth Plot on Configuration 802.11n MCS8 20MHz Ant. 1-1 + Ant. 1-3 / 5580 MHz

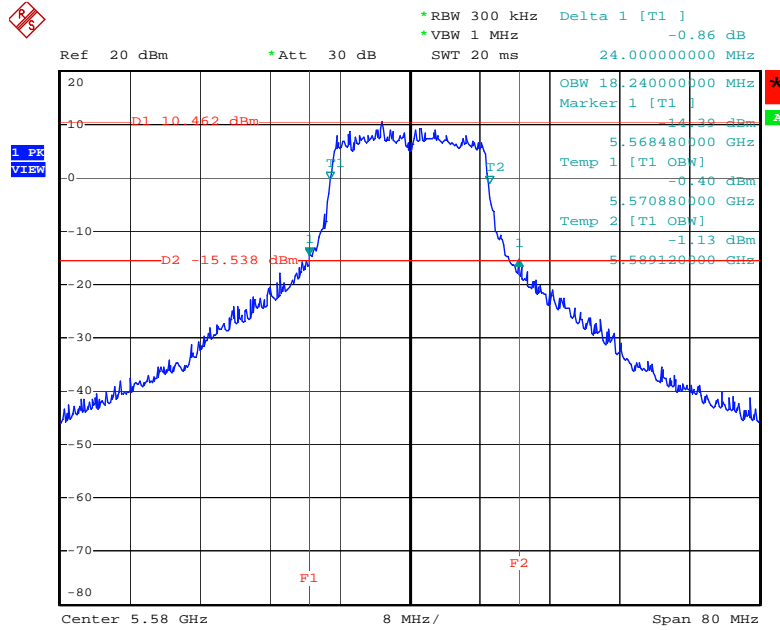

Date: 9.OCT.2009 17:29:21

26 dB Bandwidth Plot on Configuration 802.11n MCS8 20MHz Ant. 1-1 + Ant. 1-3 / 5700 MHz

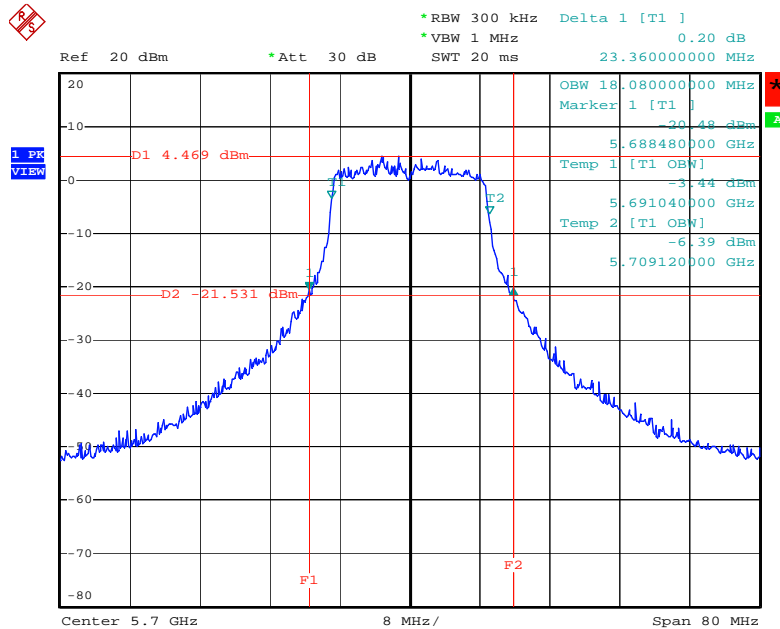

Date: 16.SEP.2009 18:43:09

26 dB Bandwidth Plot on Configuration 802.11n MCS8 40MHz Ant. 1-1 + Ant. 1-3 / 5270 MHz

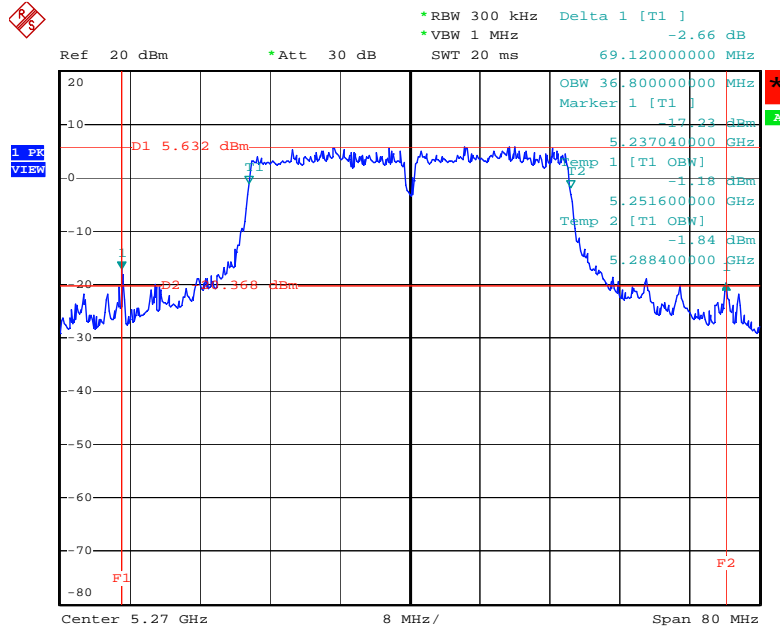

Date: 16.SEP.2009 18:51:00

26 dB Bandwidth Plot on Configuration 802.11n MCS8 40MHz Ant. 1-1 + Ant. 1-3 / 5310 MHz

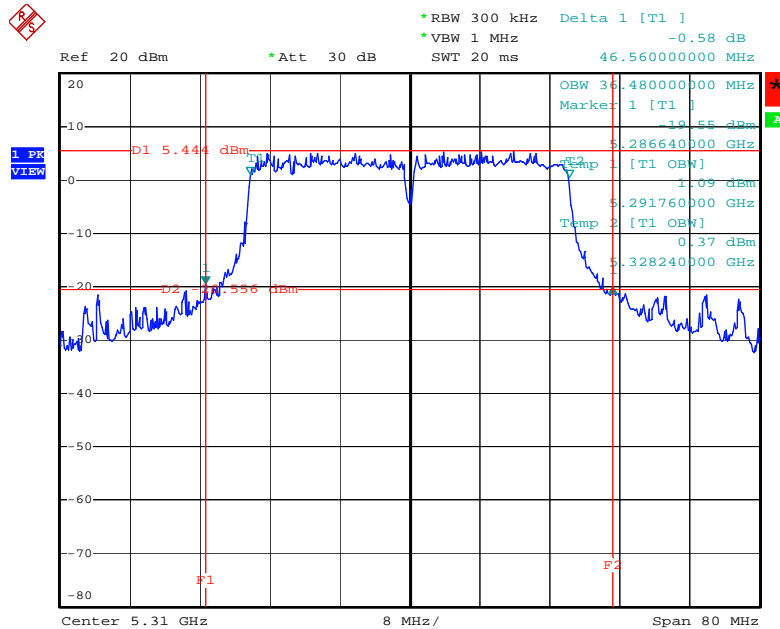

Date: 16.SEP.2009 18:55:02

26 dB Bandwidth Plot on Configuration 802.11n MCS8 40MHz Ant. 1-1 + Ant. 1-3 / 5510MHz

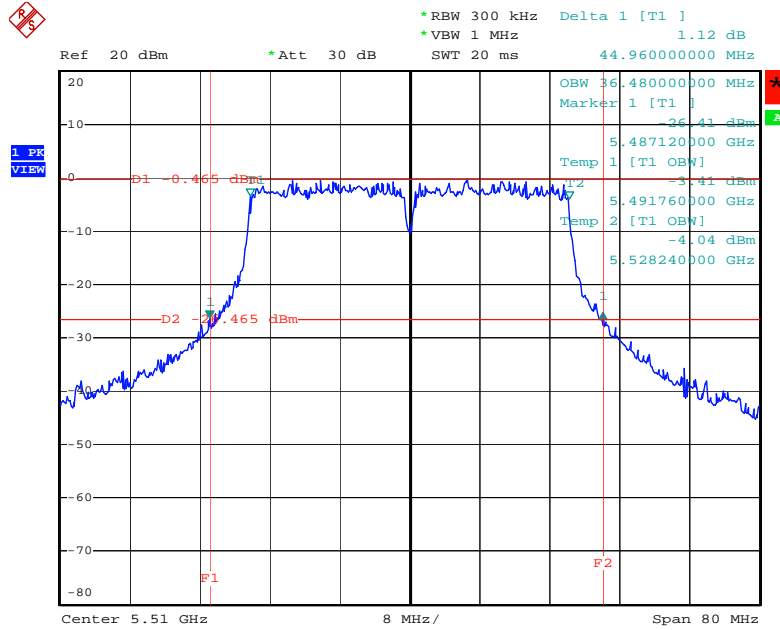

Date: 16.SEP.2009 19:03:32

26 dB Bandwidth Plot on Configuration 802.11n MCS8 40MHz Ant. 1-1 + Ant. 1-3 / 5550 MHz

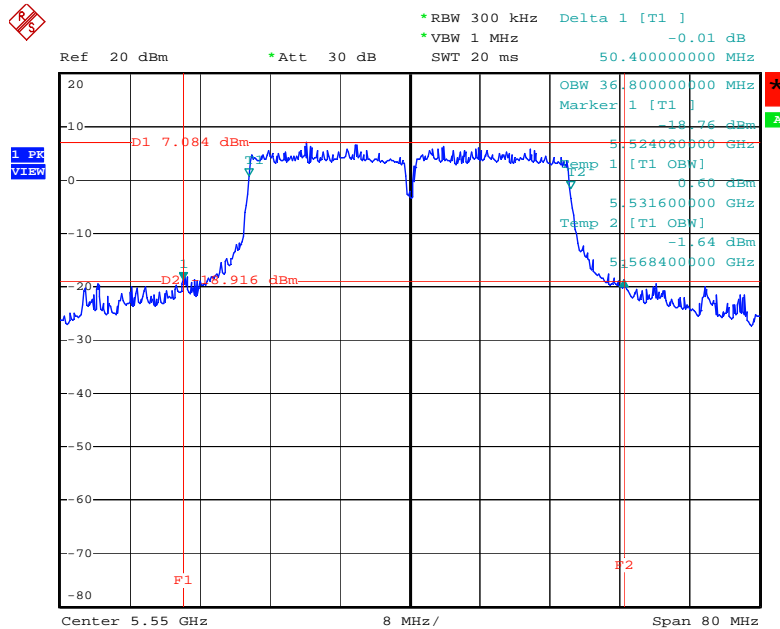

Date: 9.OCT.2009 17:35:24

26 dB Bandwidth Plot on Configuration 802.11n MCS8 40MHz Ant. 1-1 + Ant. 1-3 / 5670 MHz

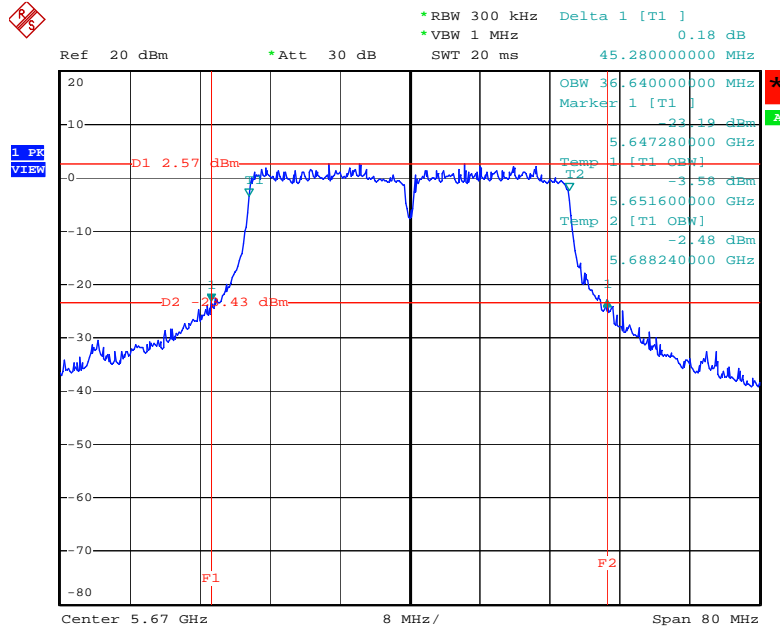

Date: 16.SEP.2009 19:13:54

26 dB Bandwidth Plot on Configuration IEEE 802.11a Ant. 1-1 + Ant. 1-3 / 5260 MHz

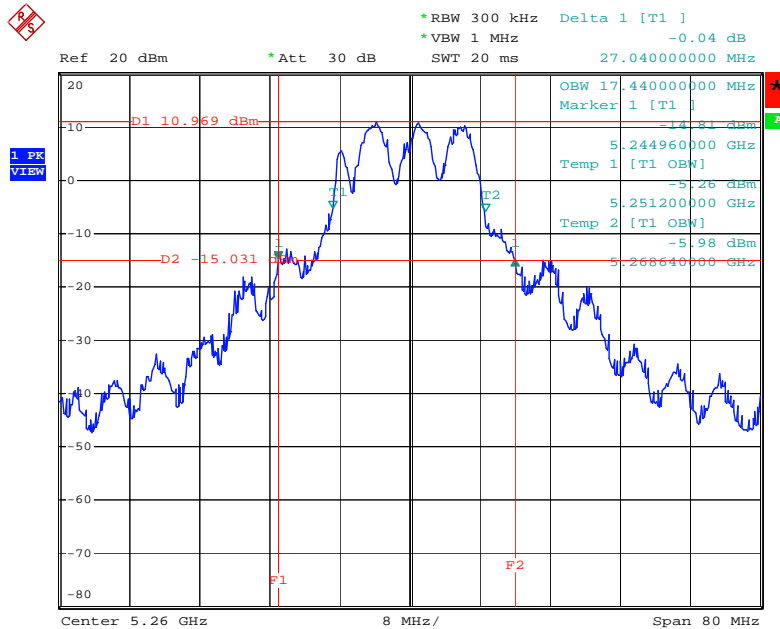

Date: 16.SEP.2009 22:49:09



26 dB Bandwidth Plot on Configuration IEEE 802.11a Ant. 1-1 + Ant. 1-3 / 5300 MHz

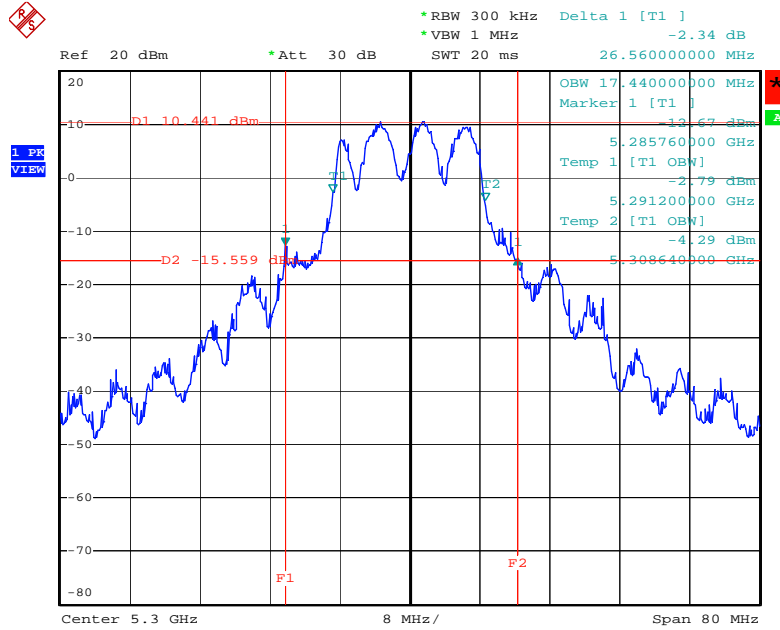

Date: 16.SEP.2009 17:42:47

26 dB Bandwidth Plot on Configuration IEEE 802.11a Ant. 1-1 + Ant. 1-3 / 5320 MHz

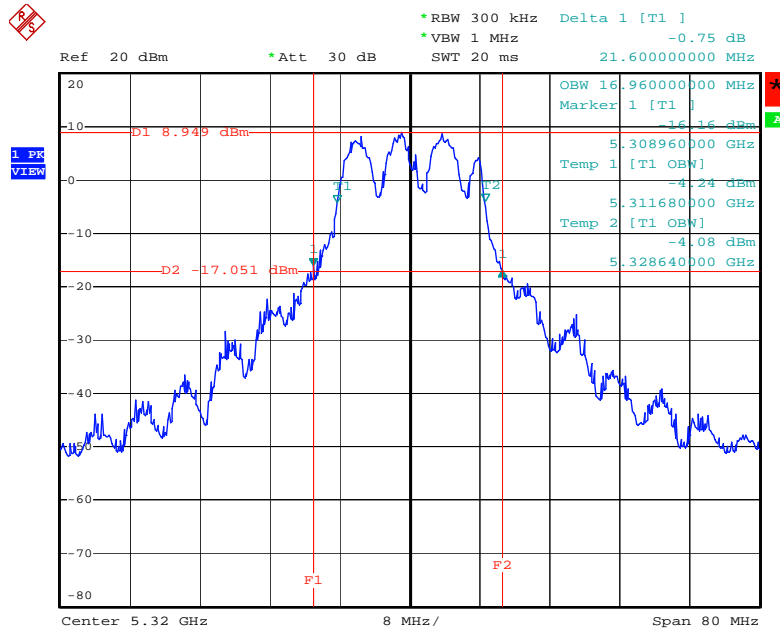

Date: 16.SEP.2009 17:46:40

26 dB Bandwidth Plot on Configuration IEEE 802.11a Ant. 1-1 + Ant. 1-3 / 5500 MHz

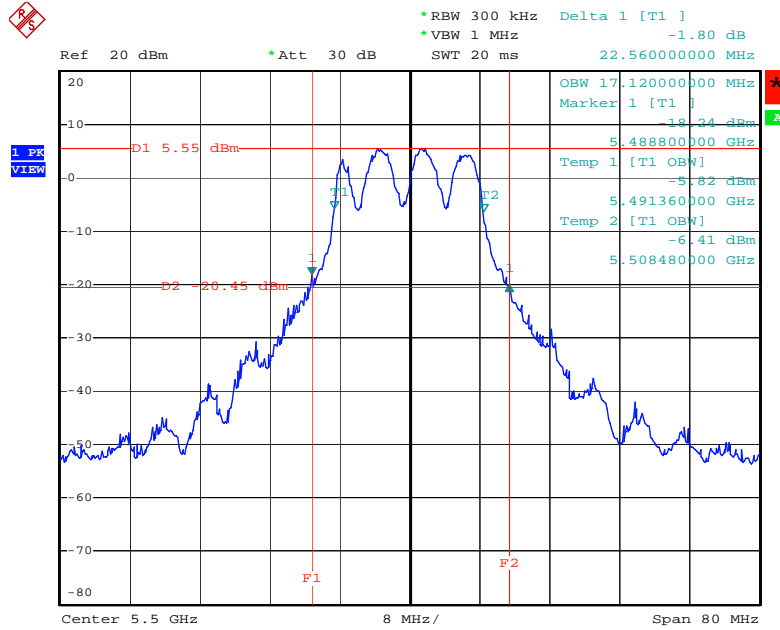

Date: 16.SEP.2009 17:51:25

26 dB Bandwidth Plot on Configuration IEEE 802.11a Ant. 1-1 + Ant. 1-3 / 5580 MHz

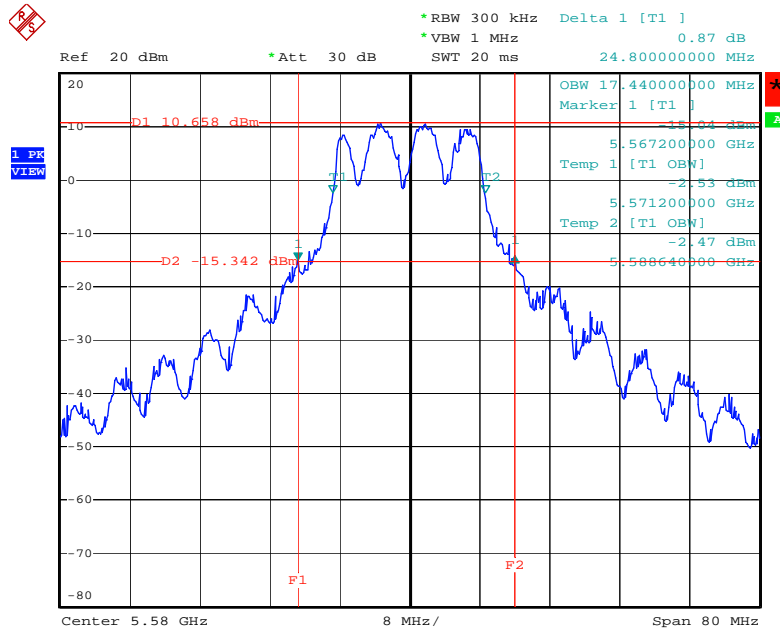

Date: 16.SEP.2009 17:57:19

26 dB Bandwidth Plot on Configuration IEEE 802.11a Ant. 1-1 + Ant. 1-3 / 5700 MHz

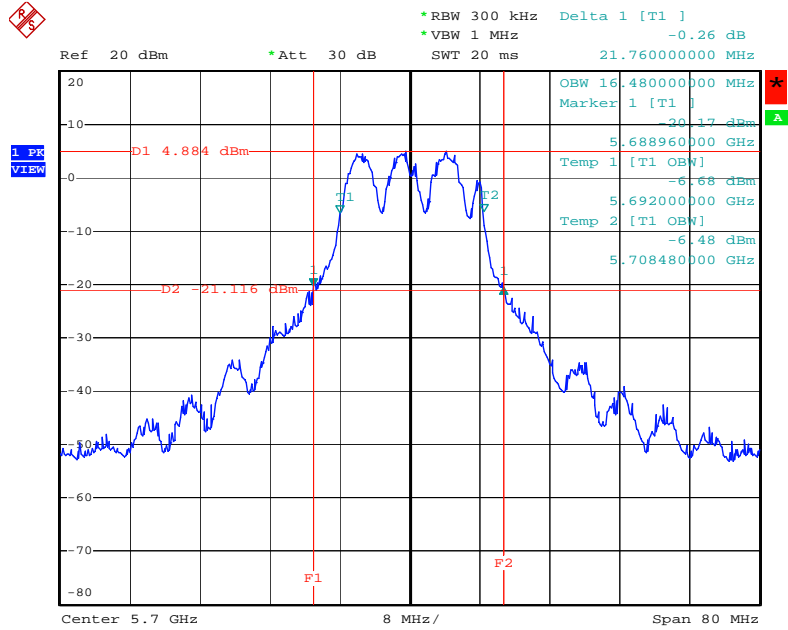

Date: 16.SEP.2009 17:58:32

<For Antenna 2>:

26 dB Bandwidth Plot on Configuration 802.11n MCS8 20MHz Ant. 2-1 + Ant. 2-3 / 5260 MHz

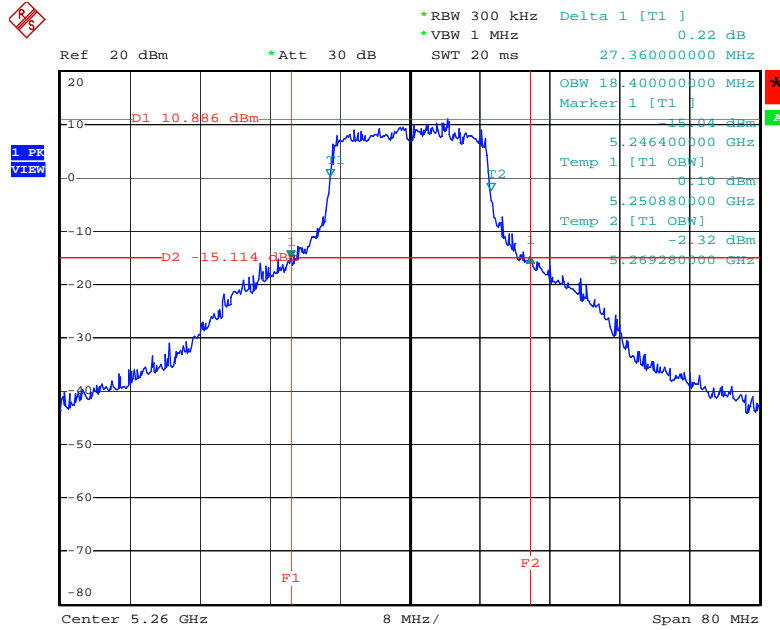

Date: 16.SEP.2009 18:24:50

26 dB Bandwidth Plot on Configuration 802.11n MCS8 20MHz Ant. 2-1 + Ant. 2-3 / 5300 MHz

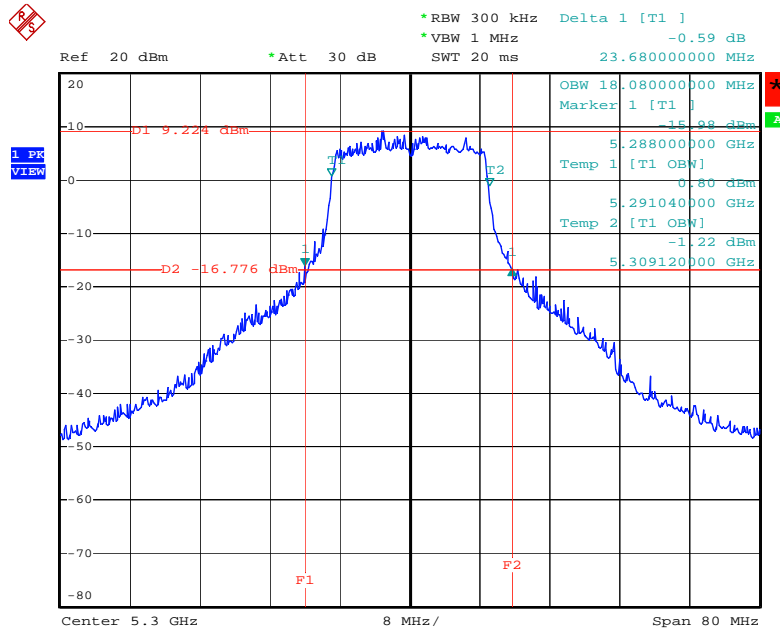

Date: 16.SEP.2009 18:26:55

26 dB Bandwidth Plot on Configuration 802.11n MCS8 20MHz Ant. 2-1 + Ant. 2-3 / 5320 MHz

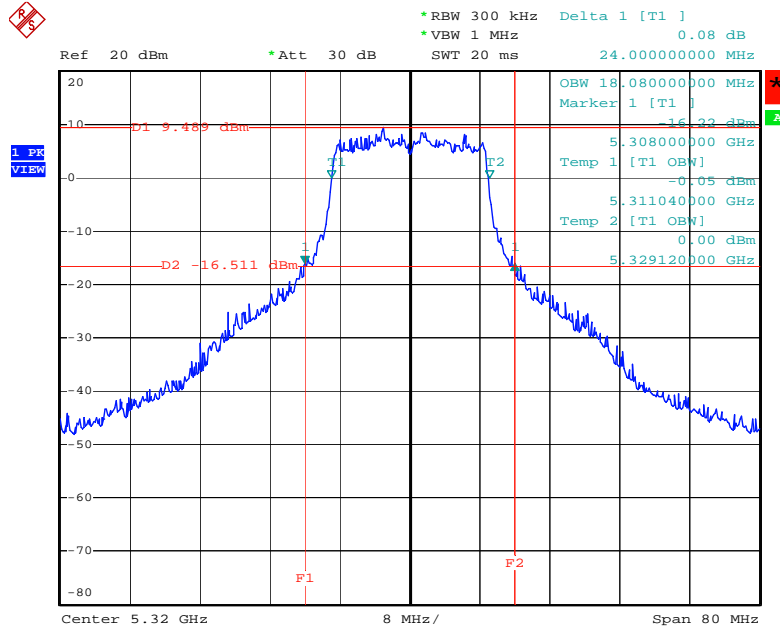

Date: 16.SEP.2009 18:30:45

26 dB Bandwidth Plot on Configuration 802.11n MCS8 20MHz Ant. 2-1 + Ant. 2-3 / 5500 MHz

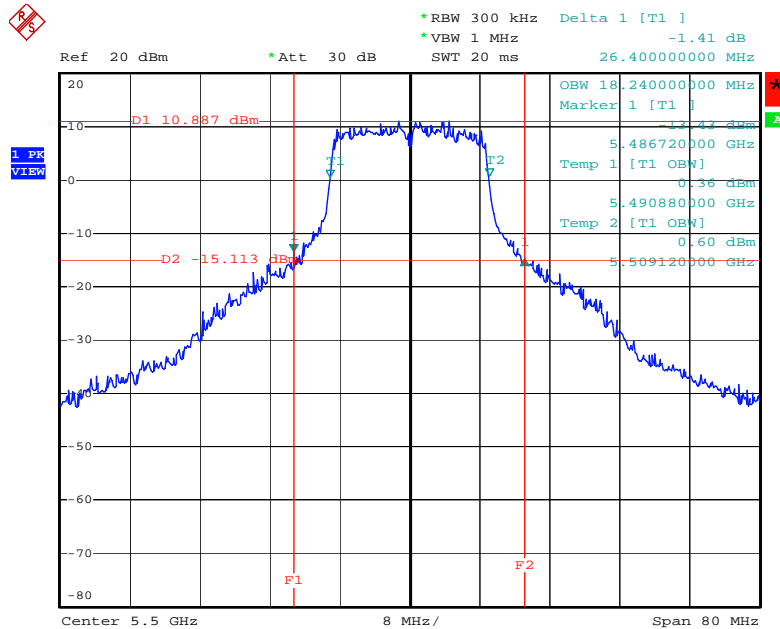

Date: 16.SEP.2009 18:34:25

26 dB Bandwidth Plot on Configuration 802.11n MCS8 20MHz Ant. 2-1 + Ant. 2-3 / 5580 MHz

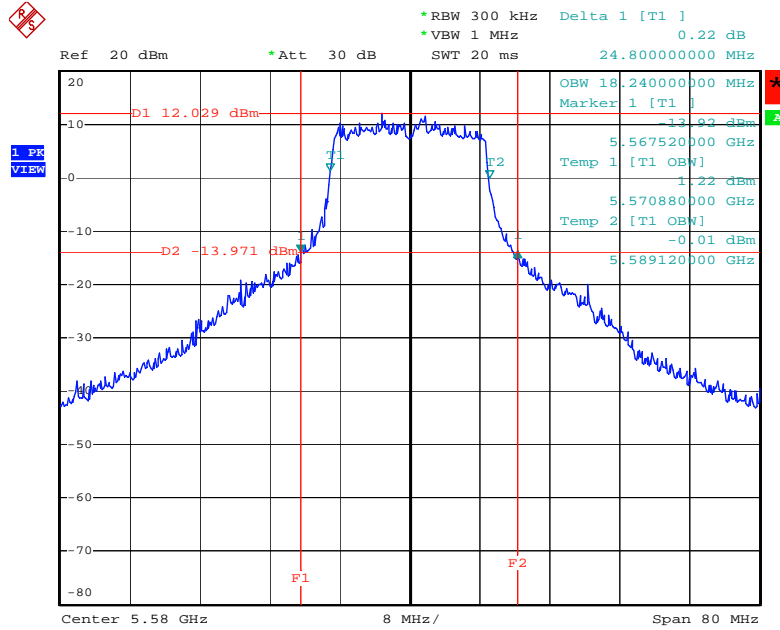

Date: 16.SEP.2009 18:38:45

26 dB Bandwidth Plot on Configuration 802.11n MCS8 20MHz Ant. 2-1 + Ant. 2-3 / 5700 MHz

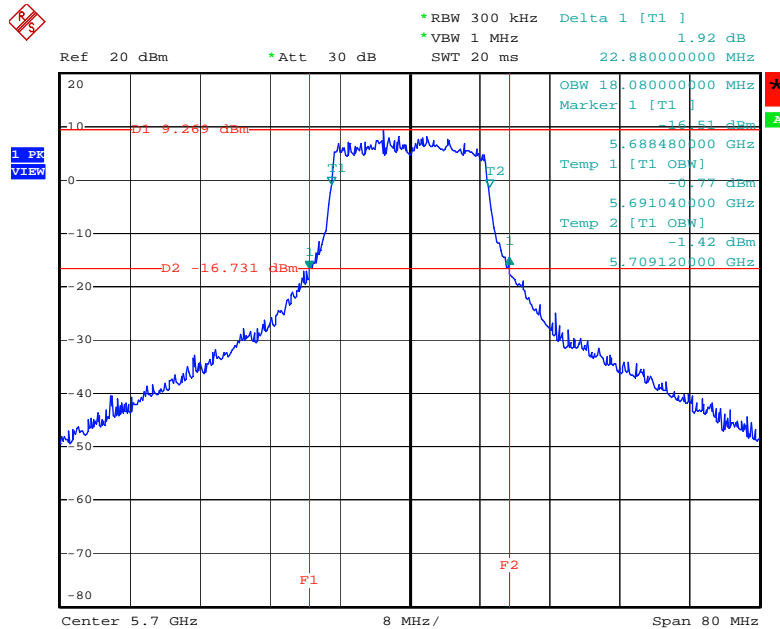

Date: 16.SEP.2009 18:44:10

26 dB Bandwidth Plot on Configuration 802.11n MCS8 40MHz Ant. 2-1 + Ant. 2-3 / 5270 MHz

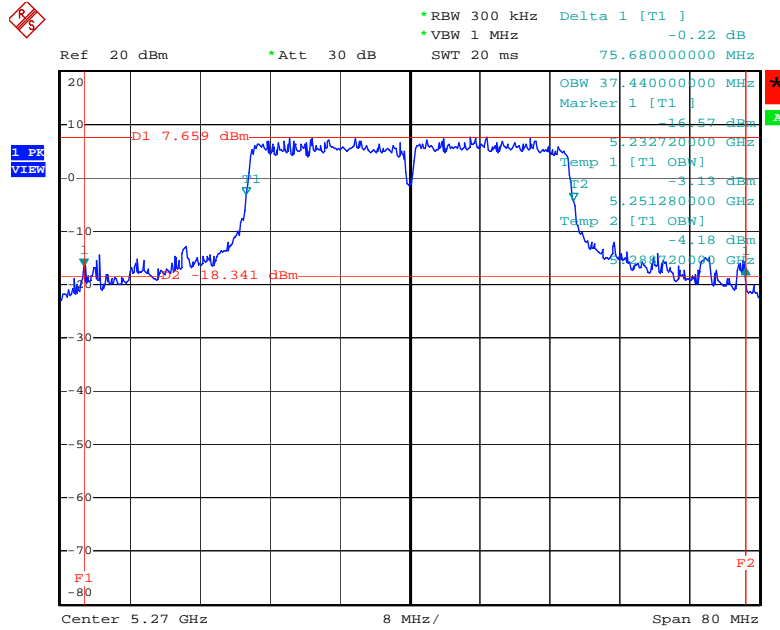

Date: 16.SEP.2009 18:52:27

26 dB Bandwidth Plot on Configuration 802.11n MCS8 40MHz Ant. 2-1 + Ant. 2-3 / 5310 MHz

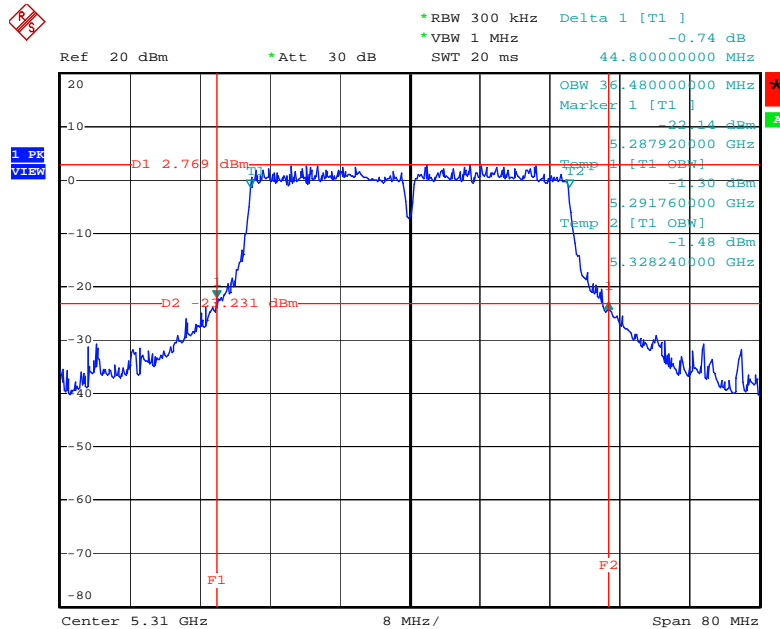

Date: 16.SEP.2009 18:57:30

26 dB Bandwidth Plot on Configuration 802.11n MCS8 40MHz Ant. 2-1 + Ant. 2-3 / 5510MHz

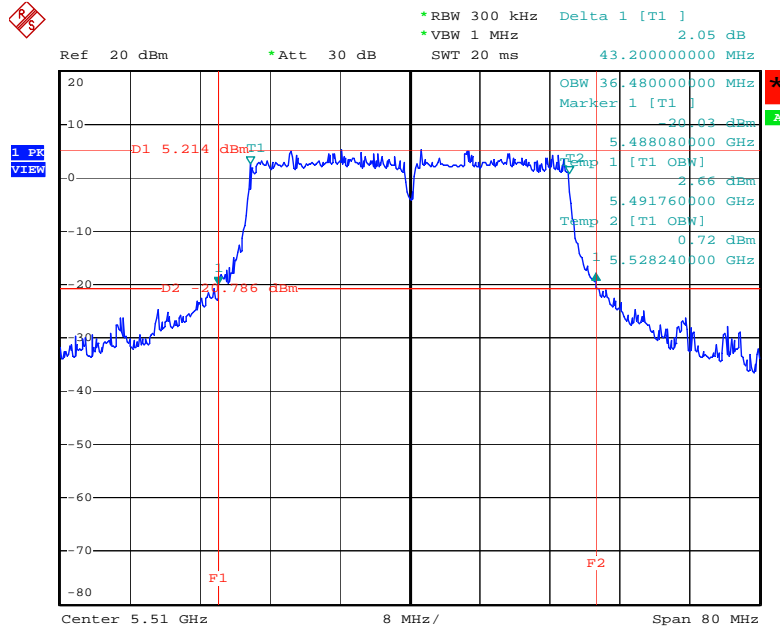

Date: 16.SEP.2009 19:04:40

26 dB Bandwidth Plot on Configuration 802.11n MCS8 40MHz Ant. 2-1 + Ant. 2-3 / 5550 MHz

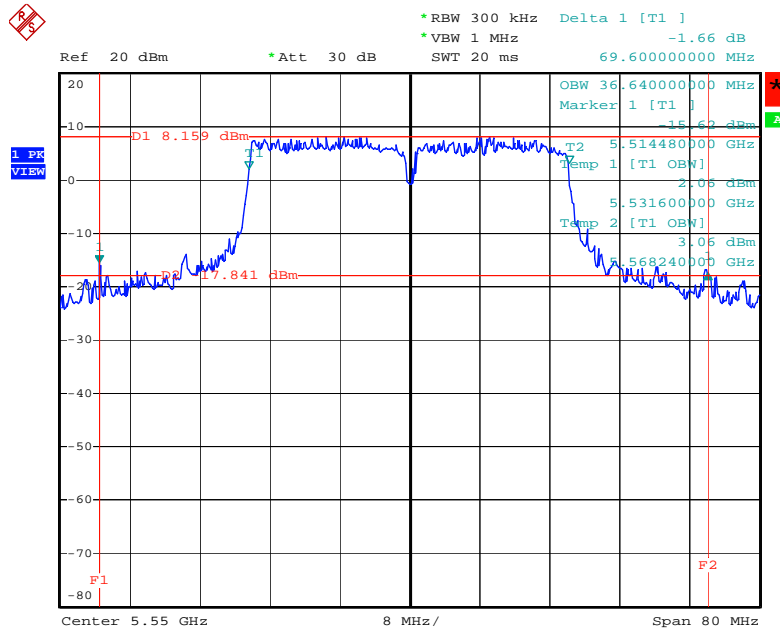

Date: 16.SEP.2009 19:10:47



26 dB Bandwidth Plot on Configuration 802.11n MCS8 40MHz Ant. 2-1 + Ant. 2-3 / 5670 MHz

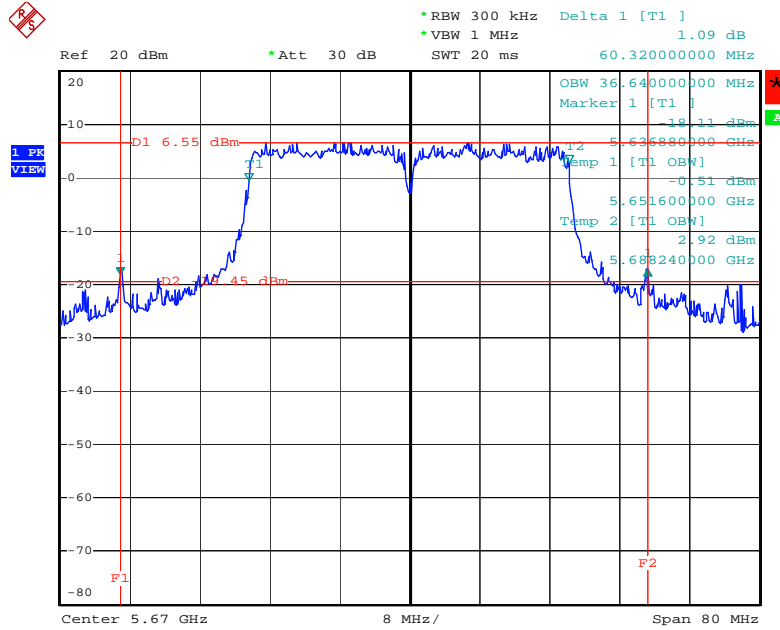

Date: 16.SEP.2009 19:14:46

26 dB Bandwidth Plot on Configuration IEEE 802.11a Ant. 2-1 + Ant. 2-3 / 5260 MHz

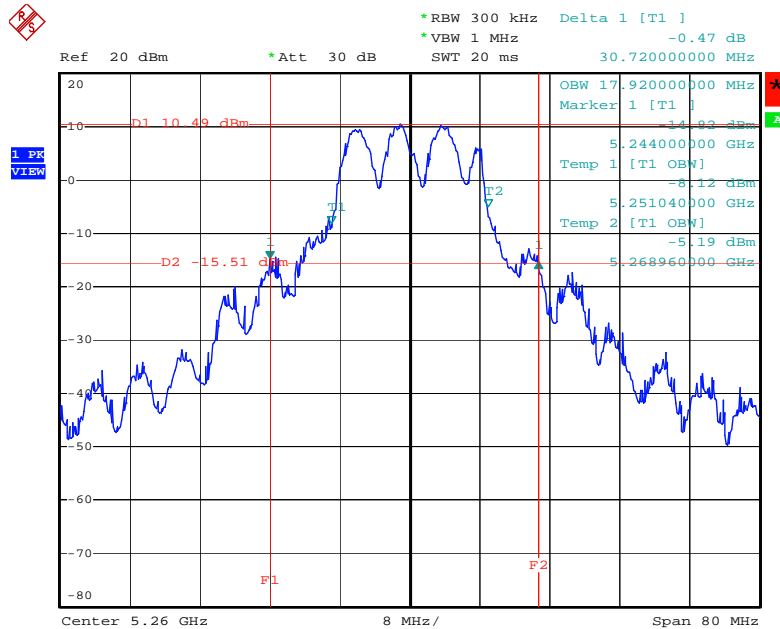

Date: 16.SEP.2009 17:41:54

26 dB Bandwidth Plot on Configuration IEEE 802.11a Ant. 2-1 + Ant. 2-3 / 5300 MHz

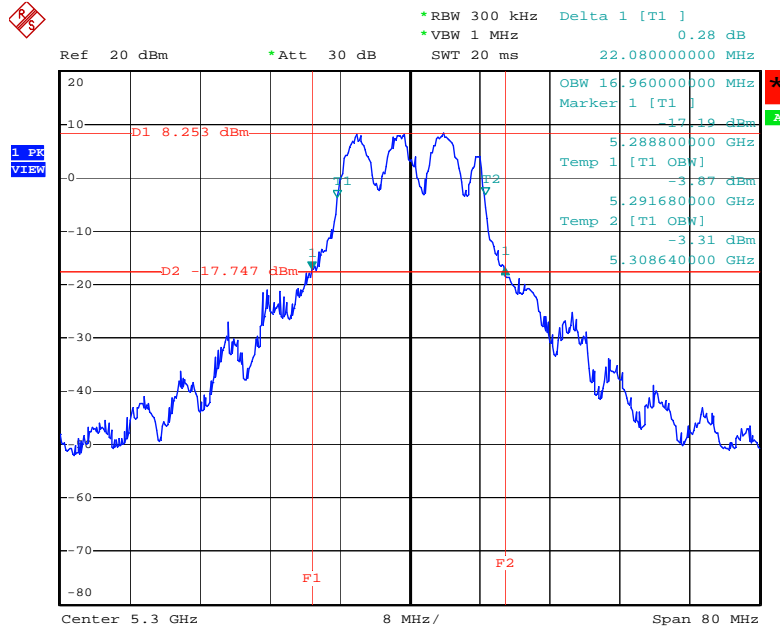

Date: 16.SEP.2009 17:43:59

26 dB Bandwidth Plot on Configuration IEEE 802.11a Ant. 2-1 + Ant. 2-3 / 5320 MHz

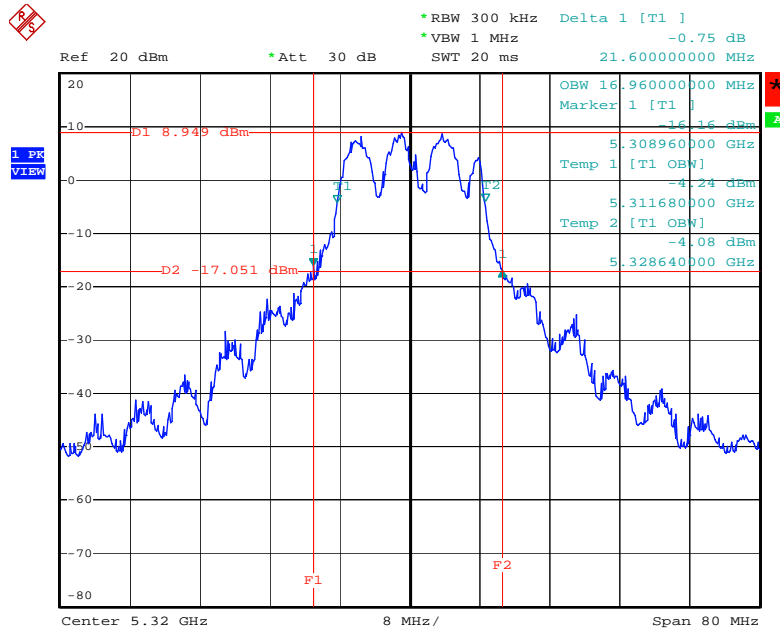

Date: 16.SEP.2009 17:46:40

26 dB Bandwidth Plot on Configuration IEEE 802.11a Ant. 2-1 + Ant. 2-3 / 5500 MHz

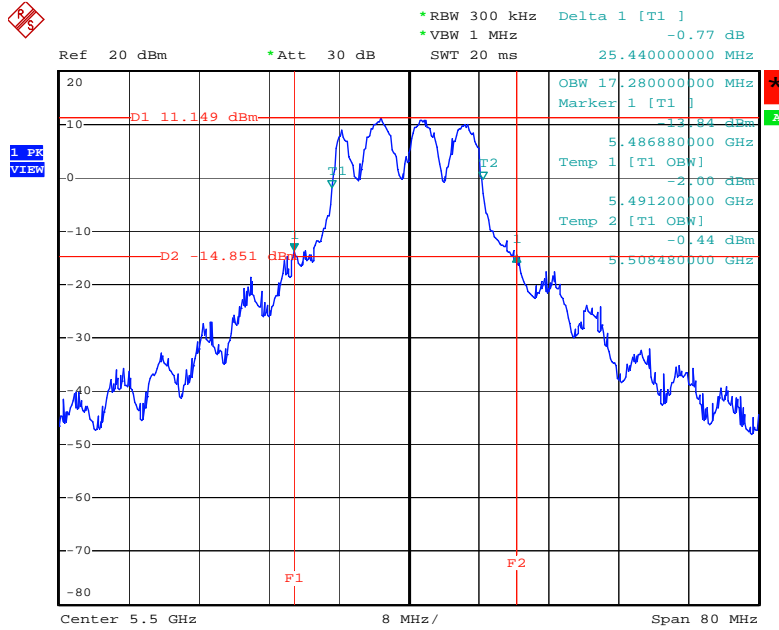

Date: 16.SEP.2009 17:52:17

26 dB Bandwidth Plot on Configuration IEEE 802.11a Ant. 2-1 + Ant. 2-3 / 5580 MHz

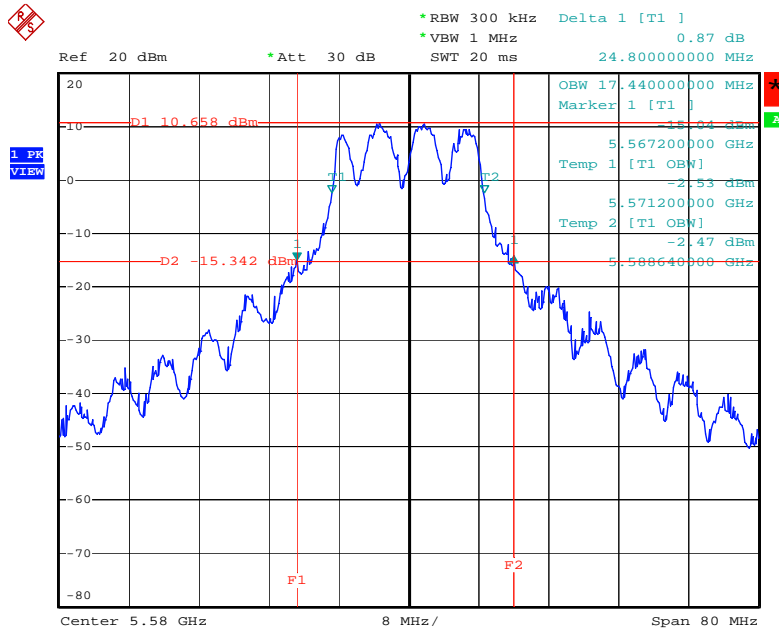

Date: 16.SEP.2009 17:57:19

26 dB Bandwidth Plot on Configuration IEEE 802.11a Ant. 2-1 + Ant. 2-3 / 5700 MHz

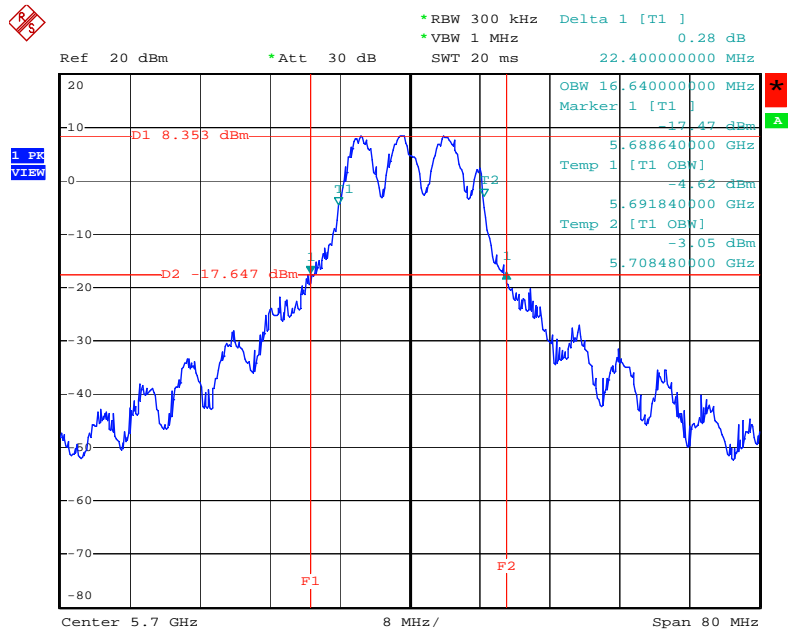

Date: 16.SEP.2009 17:59:33

<For Antenna 3>:

26 dB Bandwidth Plot on Configuration 802.11n MCS8 20MHz Ant. 3-1 + Ant. 3-3 / 5260 MHz

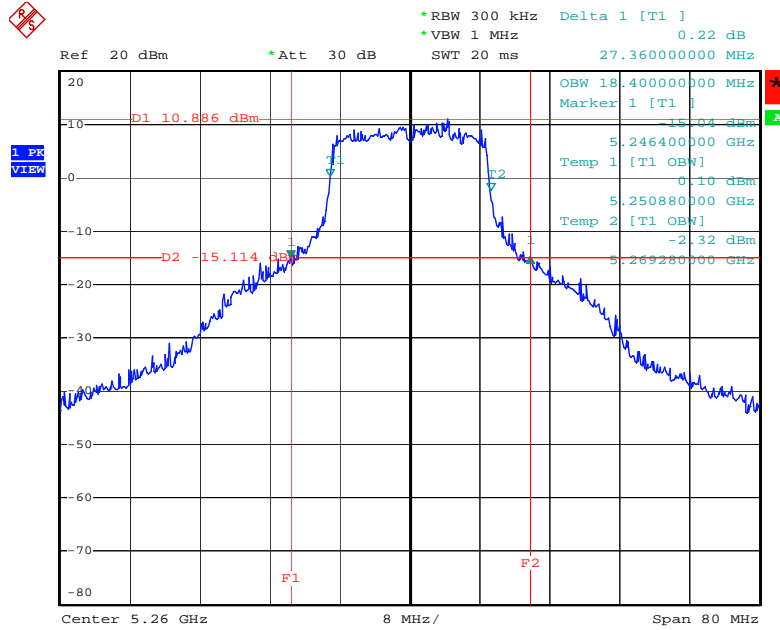

Date: 16.SEP.2009 18:24:50

26 dB Bandwidth Plot on Configuration 802.11n MCS8 20MHz Ant. 3-1 + Ant. 3-3 / 5300 MHz

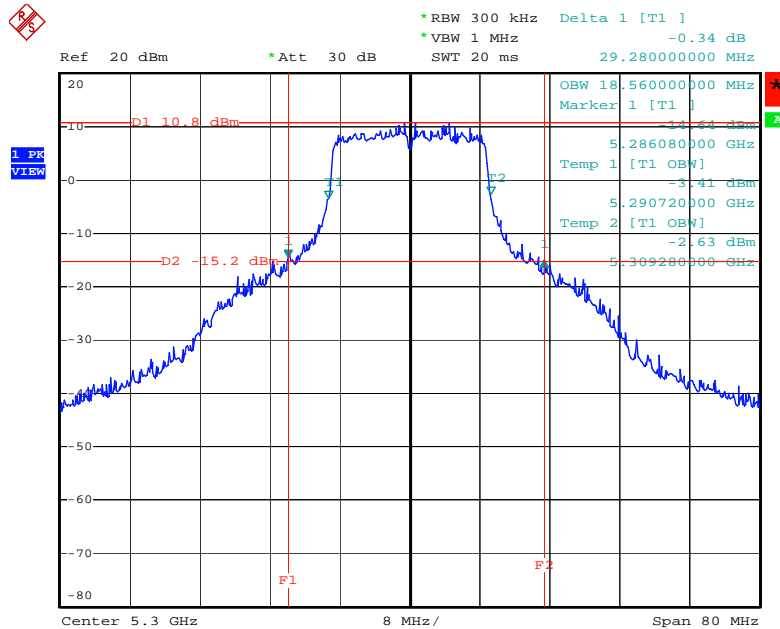

Date: 16.SEP.2009 18:27:52

26 dB Bandwidth Plot on Configuration 802.11n MCS8 20MHz Ant. 3-1 + Ant. 3-3 / 5320 MHz

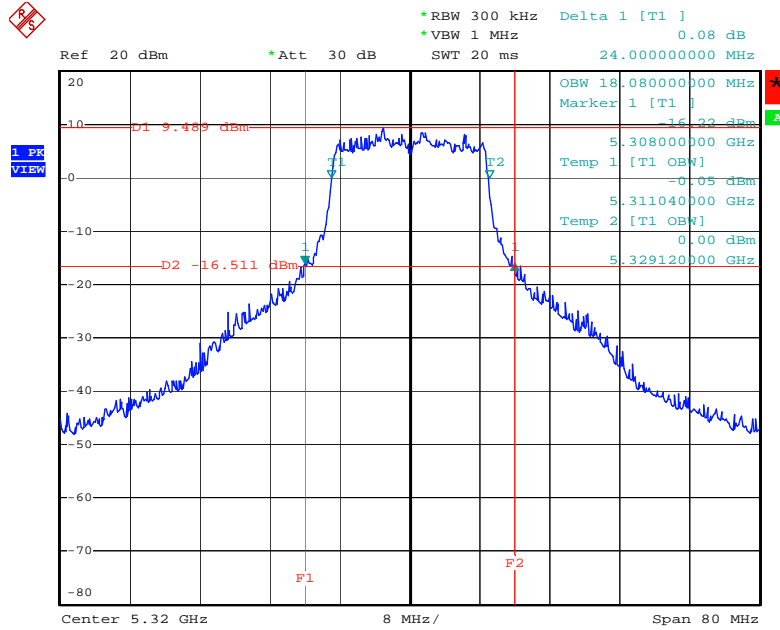

Date: 16.SEP.2009 18:30:45

26 dB Bandwidth Plot on Configuration 802.11n MCS8 20MHz Ant. 3-1 + Ant. 3-3 / 5500 MHz

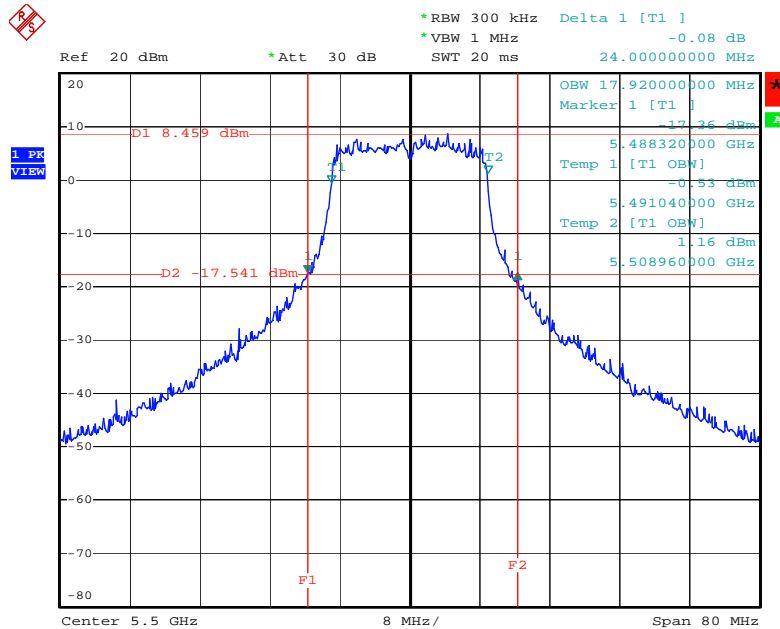

Date: 16.SEP.2009 18:35:25

26 dB Bandwidth Plot on Configuration 802.11n MCS8 20MHz Ant. 3-1 + Ant. 3-3 / 5580 MHz

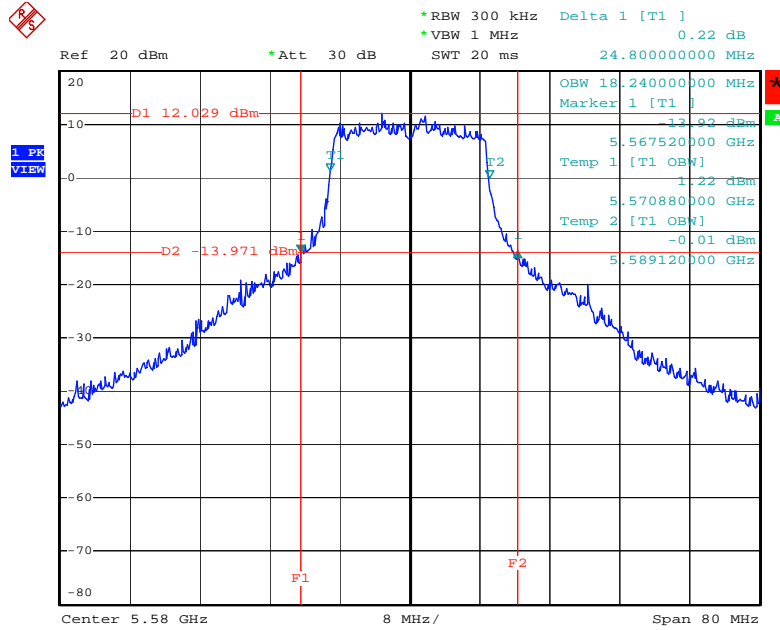

Date: 16.SEP.2009 18:38:45

26 dB Bandwidth Plot on Configuration 802.11n MCS8 20MHz Ant. 3-1 + Ant. 3-3 / 5700 MHz

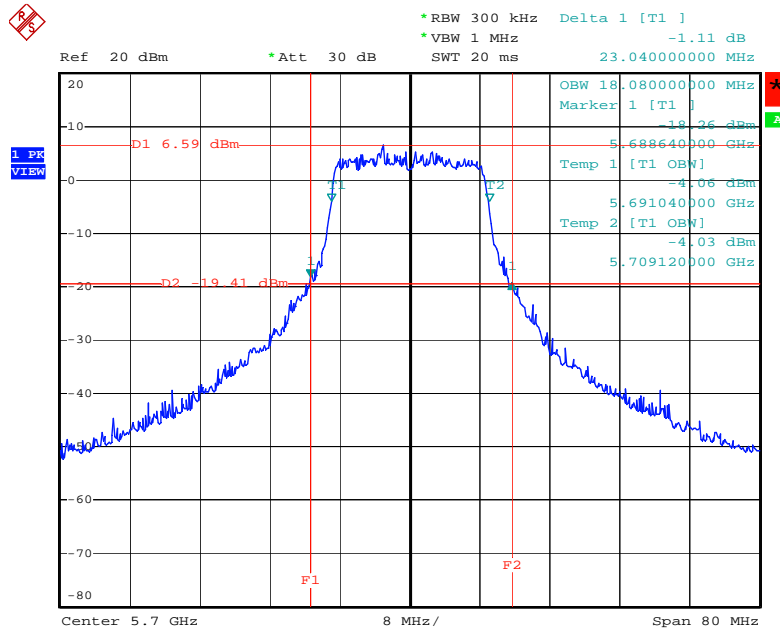

Date: 16.SEP.2009 18:45:02

26 dB Bandwidth Plot on Configuration 802.11n MCS8 40MHz Ant. 3-1 + Ant. 3-3 / 5270 MHz

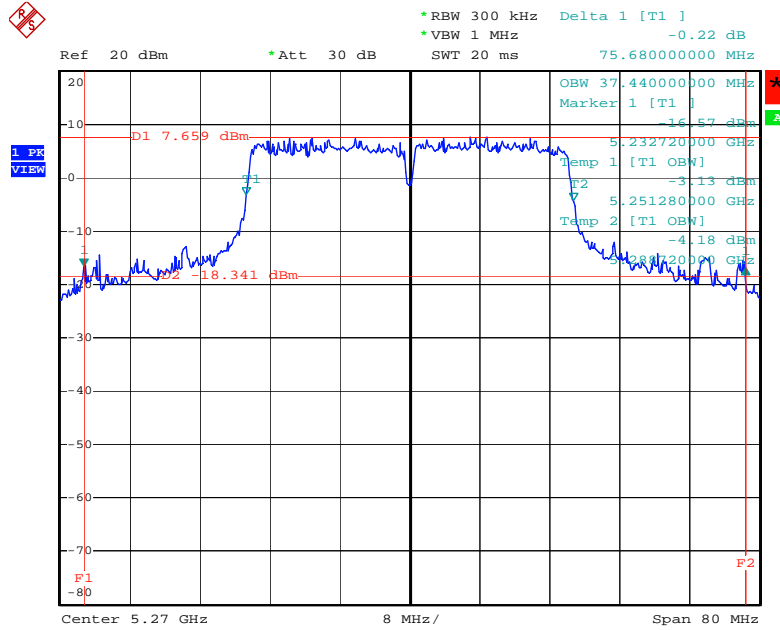

Date: 16.SEP.2009 18:52:27

26 dB Bandwidth Plot on Configuration 802.11n MCS8 40MHz Ant. 3-1 + Ant. 3-3 / 5310 MHz

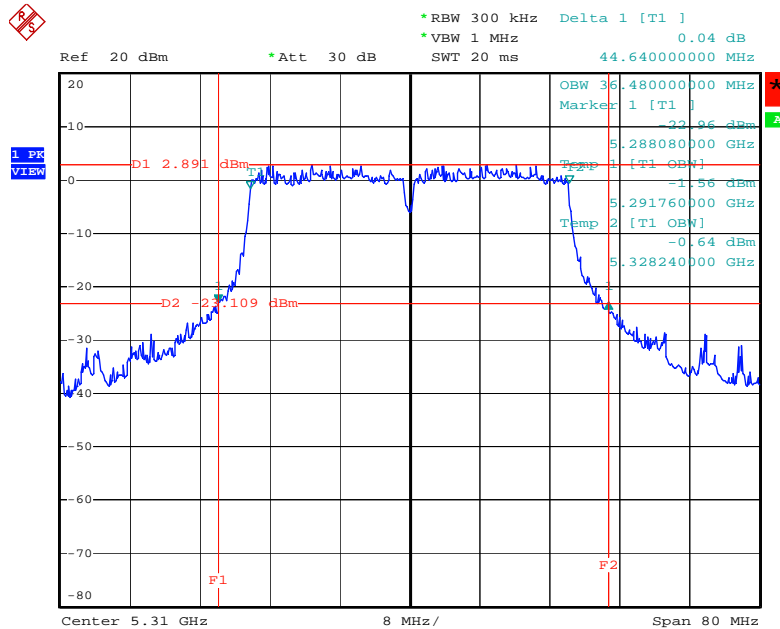

Date: 16.SEP.2009 19:01:47



26 dB Bandwidth Plot on Configuration 802.11n MCS8 40MHz Ant. 3-1 + Ant. 3-3 / 5510MHz

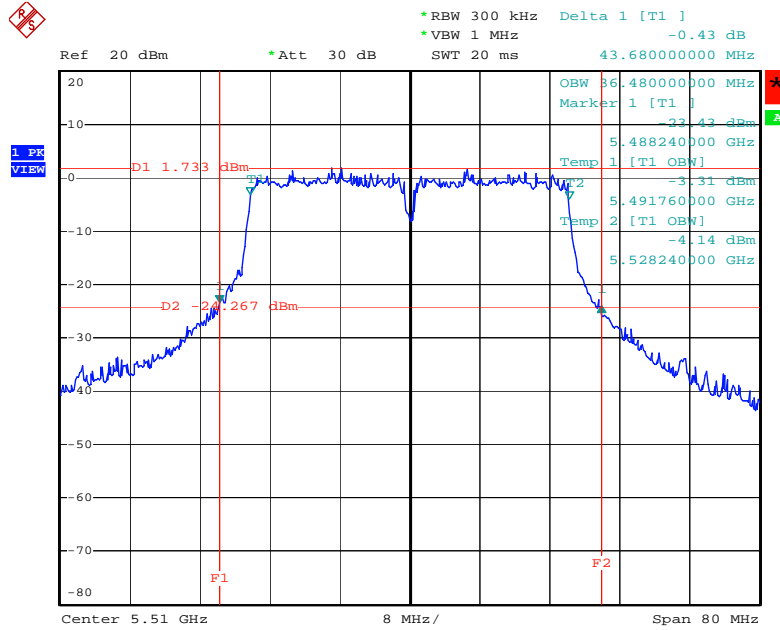

Date: 16.SEP.2009 19:05:46

26 dB Bandwidth Plot on Configuration 802.11n MCS8 40MHz Ant. 3-1 + Ant. 3-3 / 5550 MHz

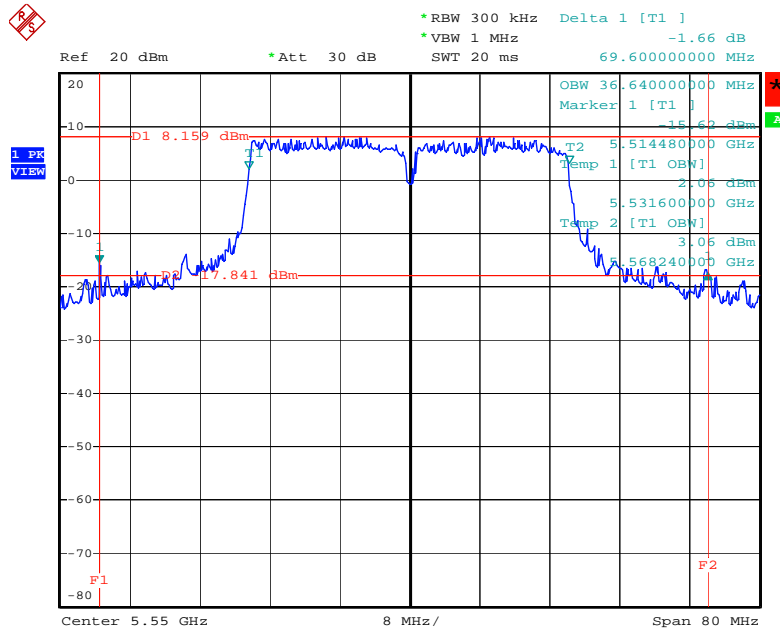

Date: 16.SEP.2009 19:10:47

26 dB Bandwidth Plot on Configuration 802.11n MCS8 40MHz Ant. 3-1 + Ant. 3-3 / 5670 MHz

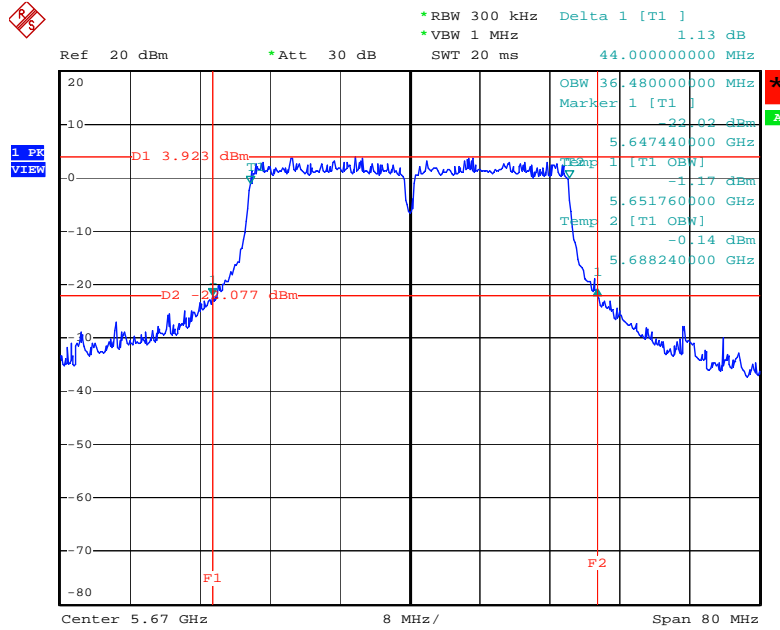

Date: 16.SEP.2009 19:15:30

26 dB Bandwidth Plot on Configuration IEEE 802.11a Ant. 3-1 + Ant. 3-3 / 5260 MHz

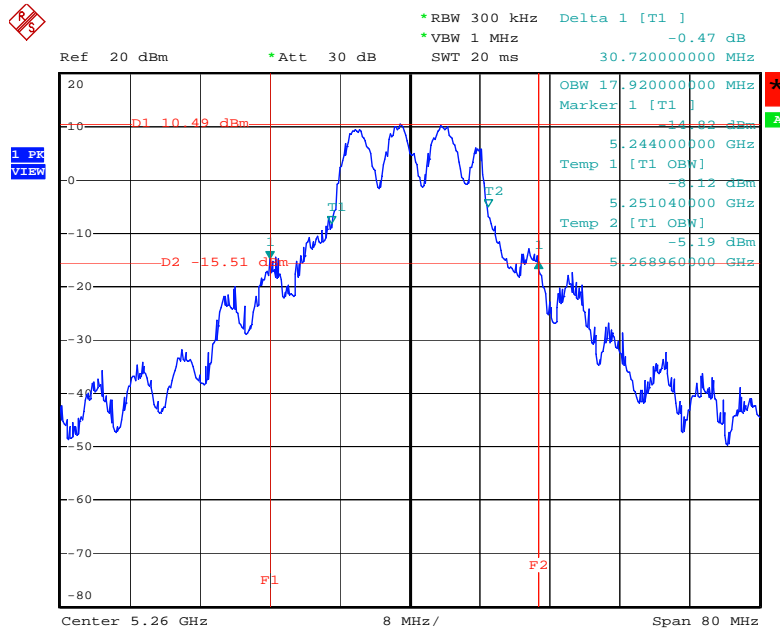

Date: 16.SEP.2009 17:41:54

26 dB Bandwidth Plot on Configuration IEEE 802.11a Ant. 3-1 + Ant. 3-3 / 5300 MHz

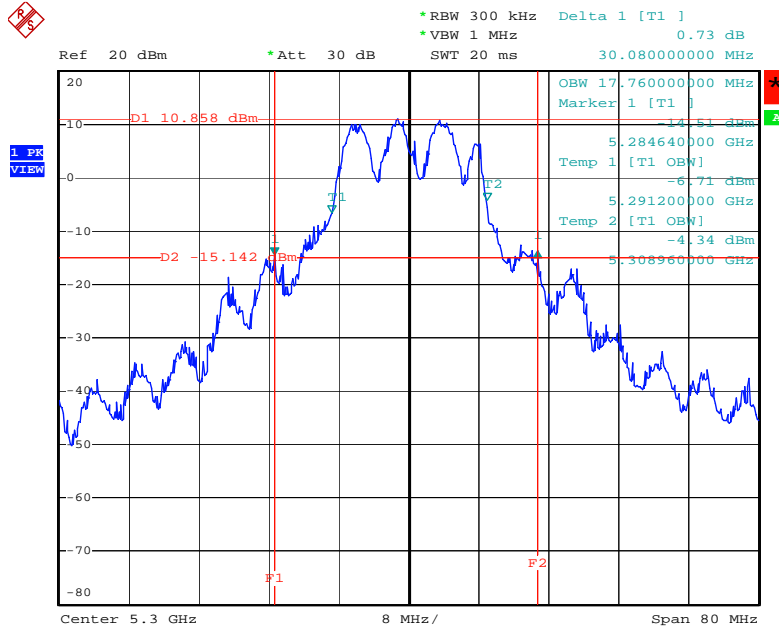

Date: 16.SEP.2009 17:45:23

26 dB Bandwidth Plot on Configuration IEEE 802.11a Ant. 3-1 + Ant. 3-3 / 5320 MHz

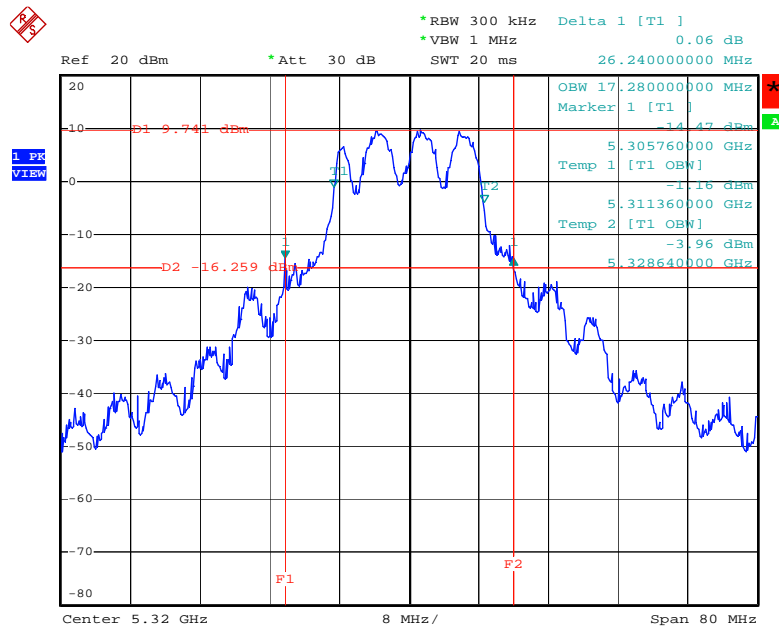

Date: 16.SEP.2009 17:48:04

26 dB Bandwidth Plot on Configuration IEEE 802.11a Ant. 3-1 + Ant. 3-3 / 5500 MHz

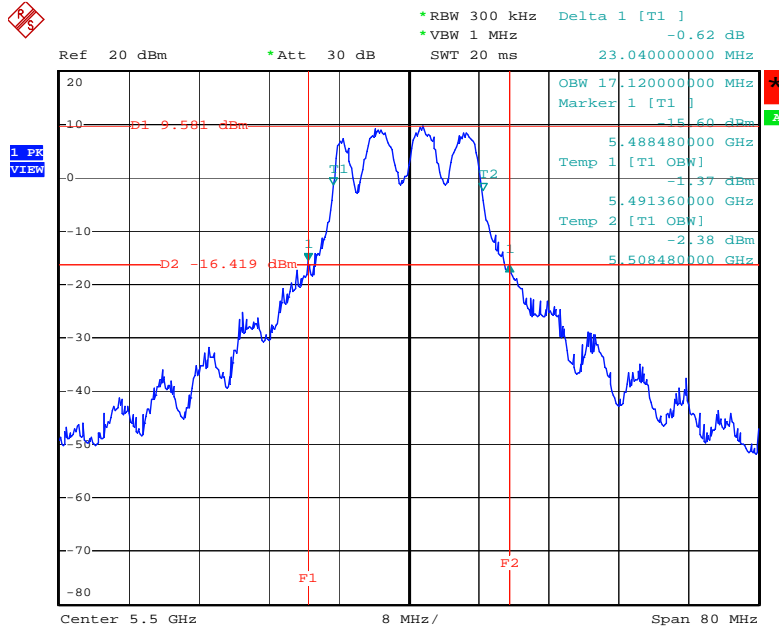

Date: 16.SEP.2009 17:53:11

26 dB Bandwidth Plot on Configuration IEEE 802.11a Ant. 3-1 + Ant. 3-3 / 5580 MHz

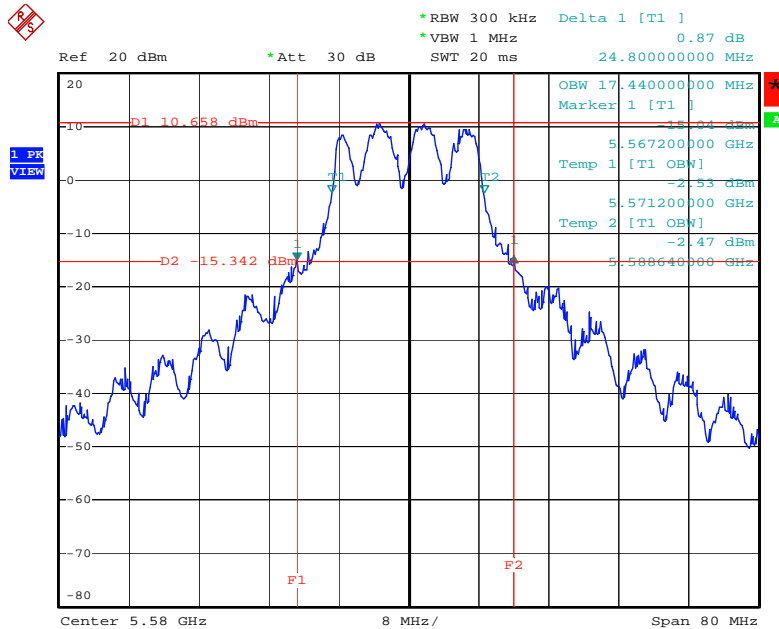

Date: 16.SEP.2009 17:57:19

26 dB Bandwidth Plot on Configuration IEEE 802.11a Ant. 3-1 + Ant. 3-3 / 5700 MHz

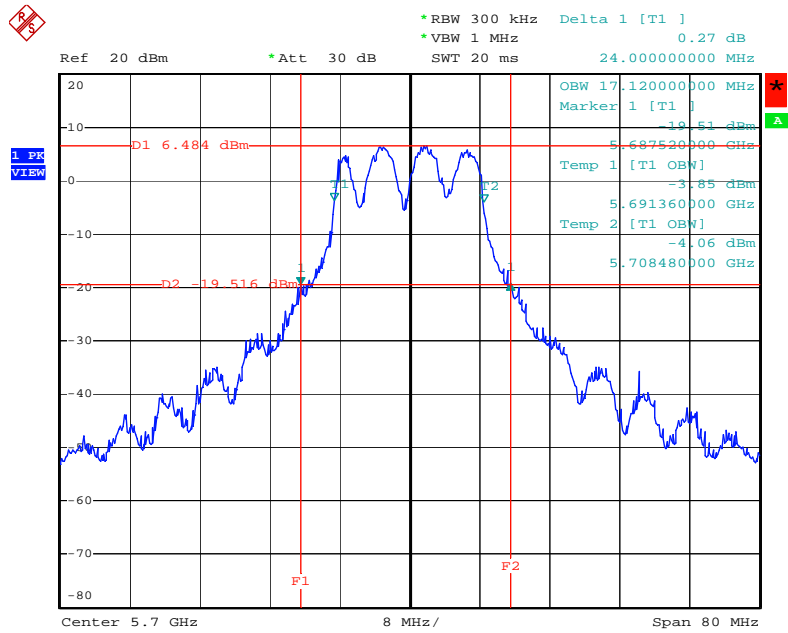

Date: 16.SEP.2009 18:01:08

<For Antenna 4>:

26 dB Bandwidth Plot on Configuration 802.11n MCS8 20MHz Ant. 4-1 + Ant. 4-3 / 5260 MHz

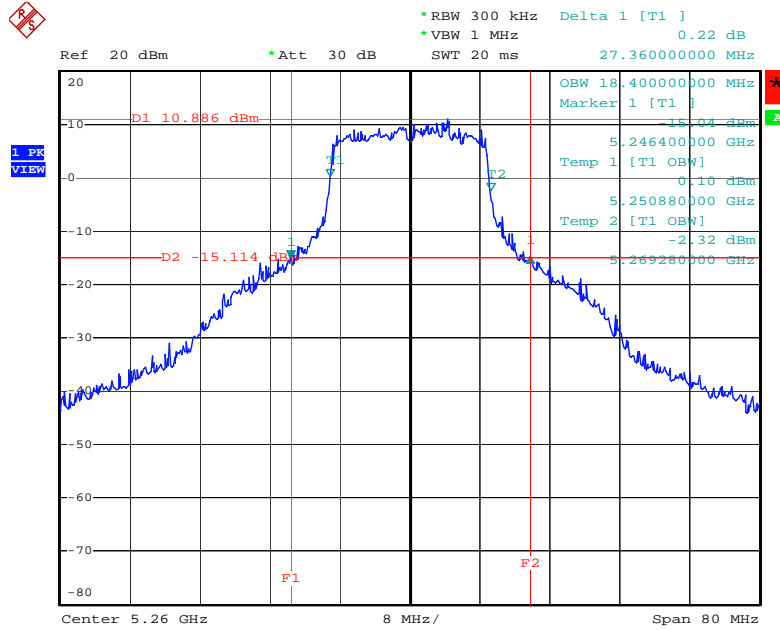

Date: 16.SEP.2009 18:24:50

26 dB Bandwidth Plot on Configuration 802.11n MCS8 20MHz Ant. 4-1 + Ant. 4-3 / 5300 MHz

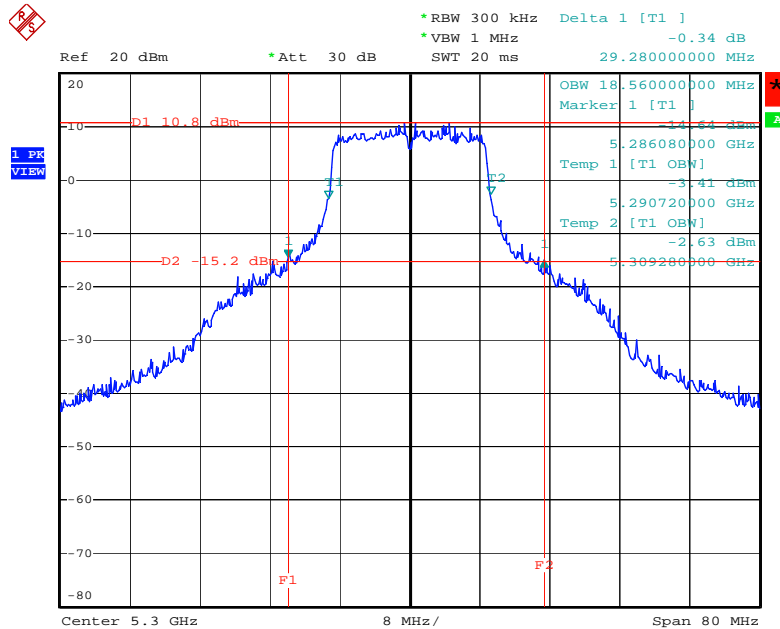

Date: 16.SEP.2009 18:27:52

26 dB Bandwidth Plot on Configuration 802.11n MCS8 20MHz Ant. 4-1 + Ant. 4-3 / 5320 MHz

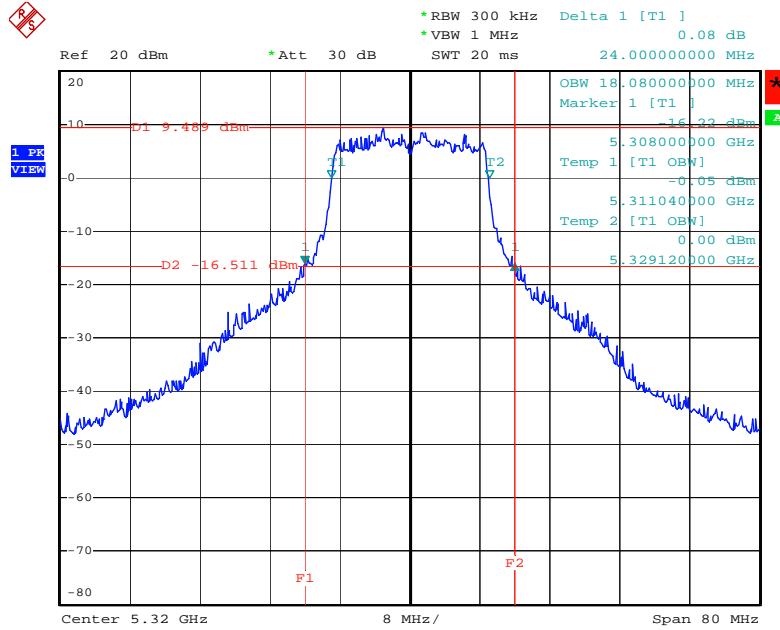

Date: 16.SEP.2009 18:30:45

26 dB Bandwidth Plot on Configuration 802.11n MCS8 20MHz Ant. 4-1 + Ant. 4-3 / 5500 MHz

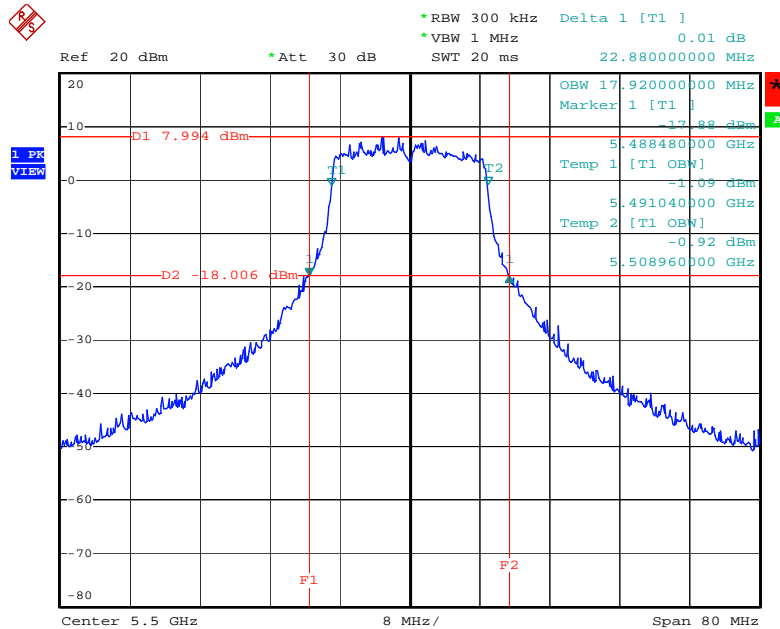

Date: 16.SEP.2009 18:36:22

26 dB Bandwidth Plot on Configuration 802.11n MCS8 20MHz Ant. 4-1 + Ant. 4-3 / 5580 MHz

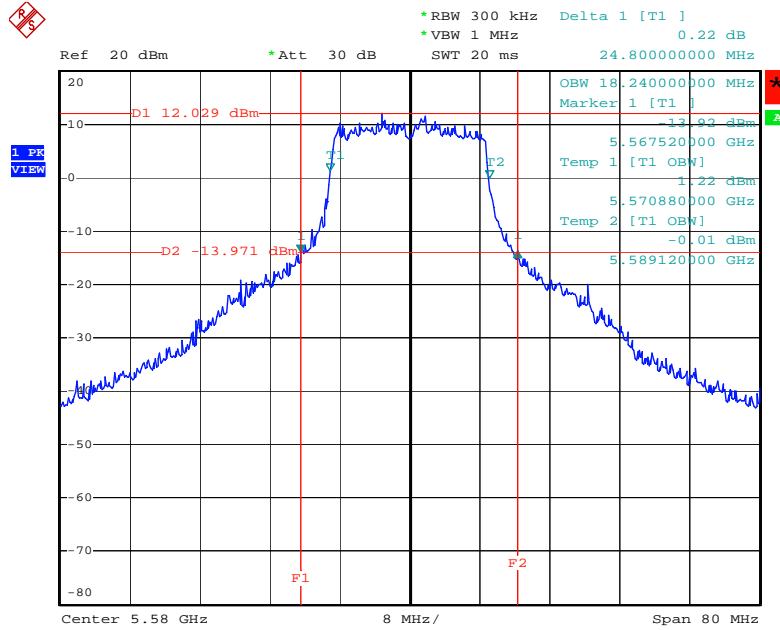

Date: 16.SEP.2009 18:38:45

26 dB Bandwidth Plot on Configuration 802.11n MCS8 20MHz Ant. 4-1 + Ant. 4-3 / 5700 MHz

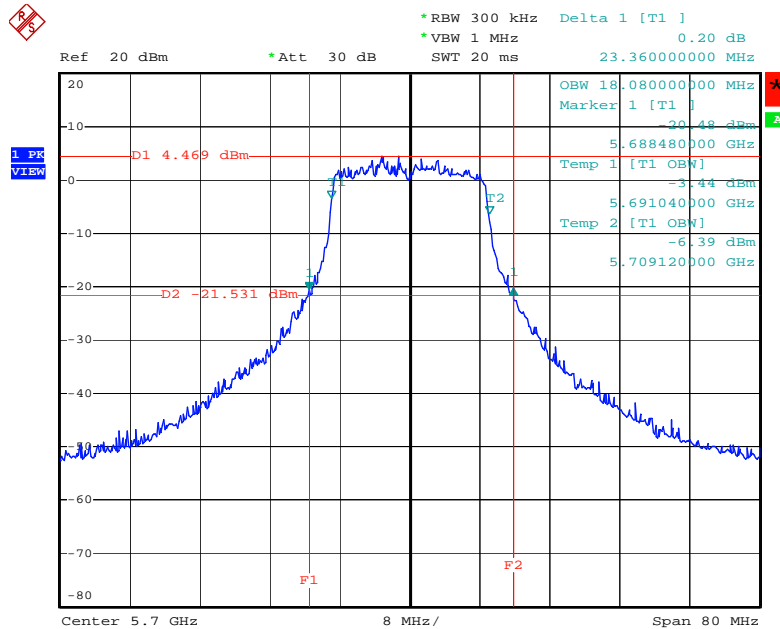

Date: 16.SEP.2009 18:43:09



26 dB Bandwidth Plot on Configuration 802.11n MCS8 40MHz Ant. 4-1 + Ant. 4-3 / 5270 MHz

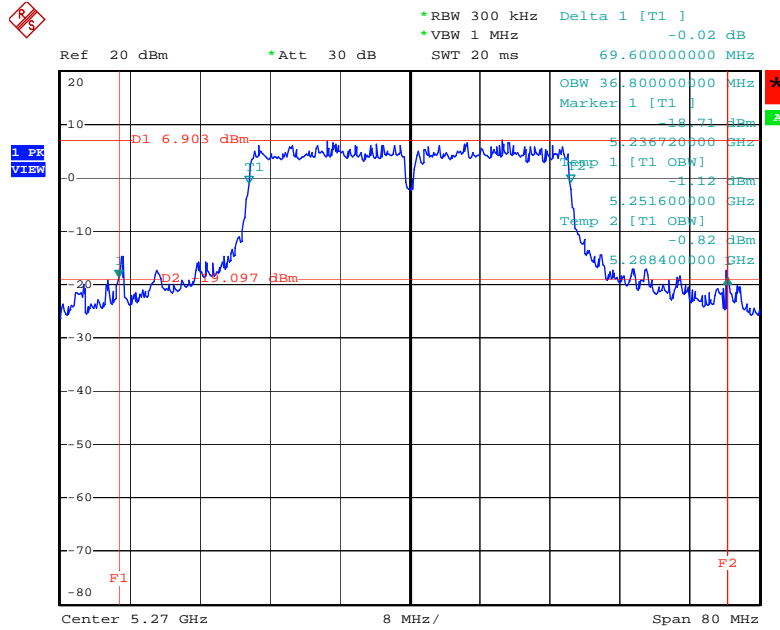

Date: 16.SEP.2009 18:53:40

26 dB Bandwidth Plot on Configuration 802.11n MCS8 40MHz Ant. 4-1 + Ant. 4-3 / 5310 MHz

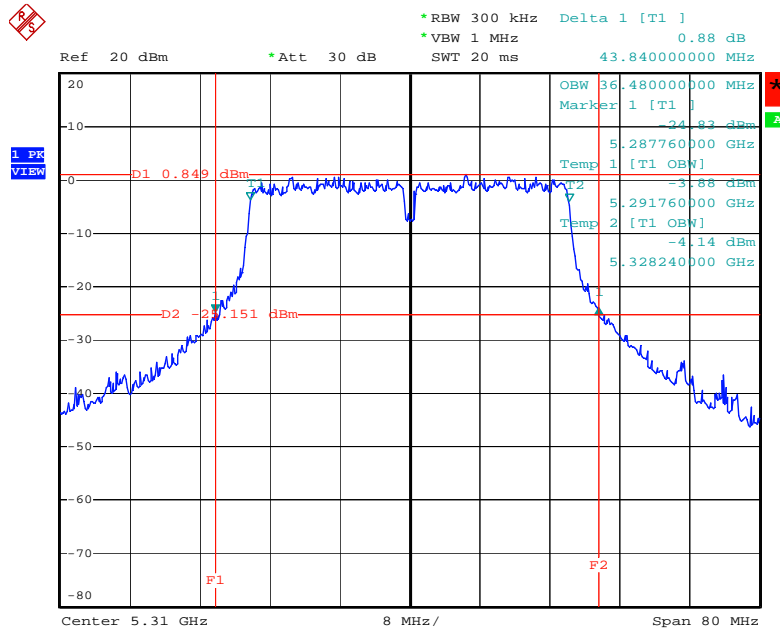

Date: 16.SEP.2009 18:58:19

26 dB Bandwidth Plot on Configuration 802.11n MCS8 40MHz Ant. 4-1 + Ant. 4-3 / 5510MHz

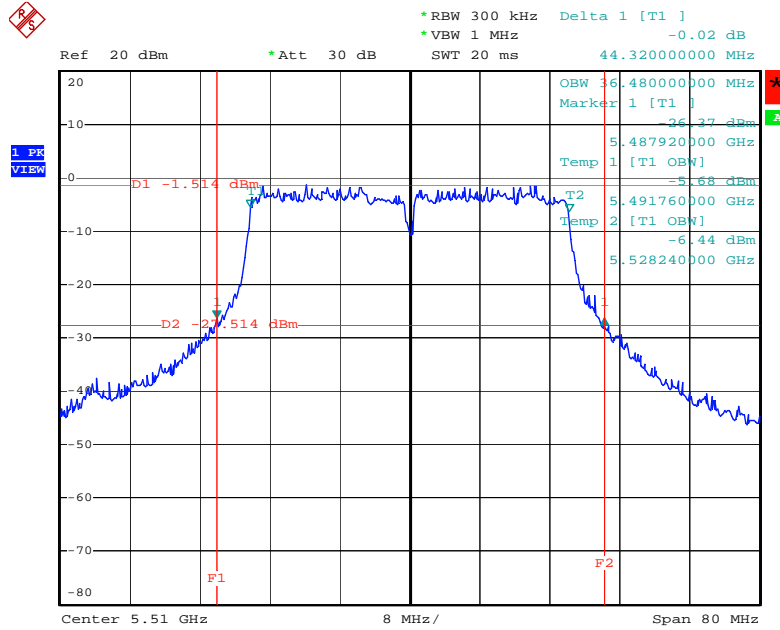

Date: 16.SEP.2009 19:08:14

26 dB Bandwidth Plot on Configuration 802.11n MCS8 40MHz Ant. 4-1 + Ant. 4-3 / 5550 MHz

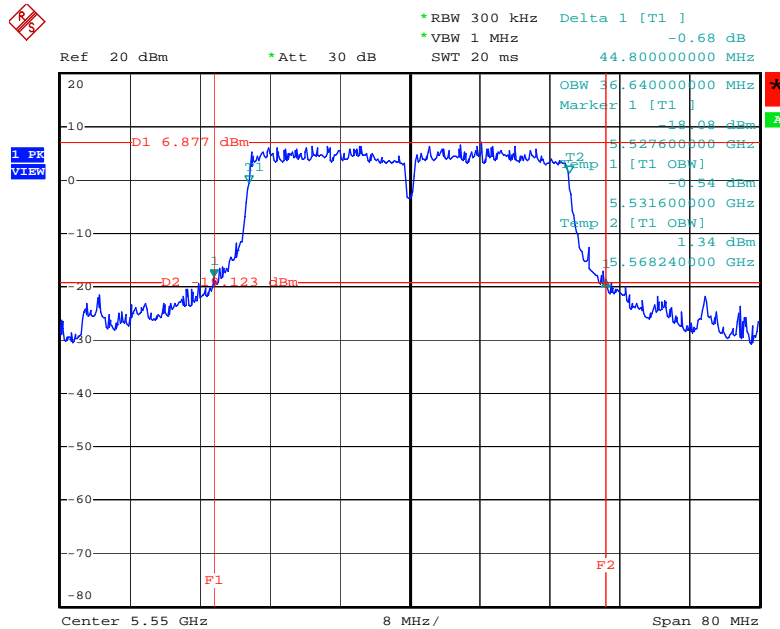

Date: 16.SEP.2009 19:11:38

26 dB Bandwidth Plot on Configuration 802.11n MCS8 40MHz Ant. 4-1 + Ant. 4-3 / 5670 MHz

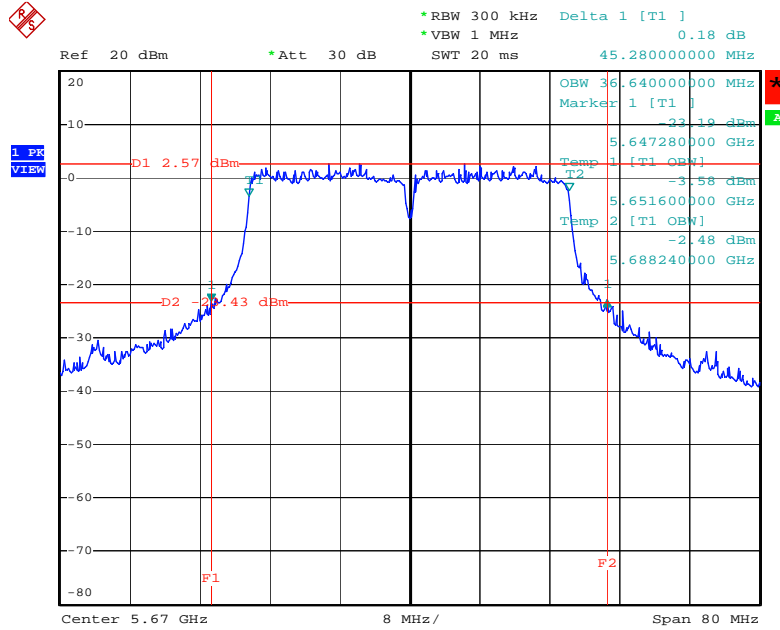

Date: 16.SEP.2009 19:13:54

26 dB Bandwidth Plot on Configuration IEEE 802.11a Ant. 4-1 + Ant. 4-3 / 5260 MHz

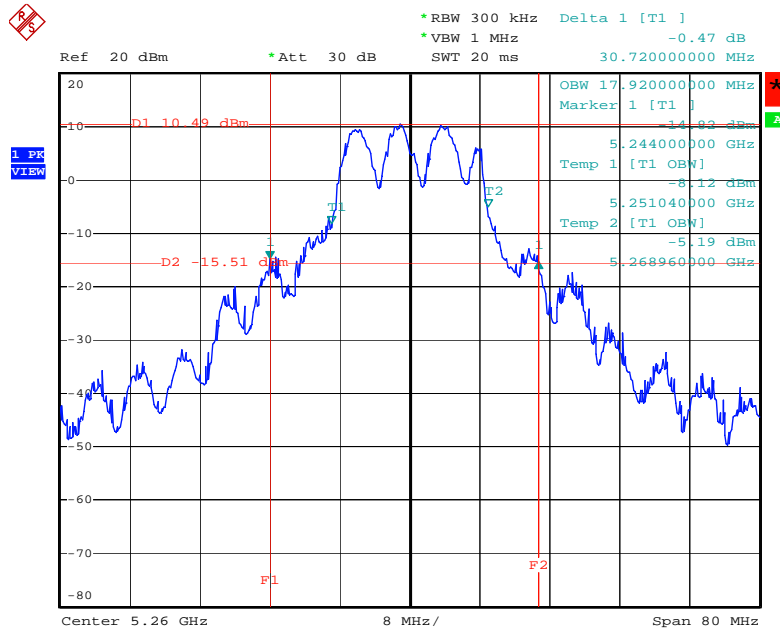

Date: 16.SEP.2009 17:41:54

26 dB Bandwidth Plot on Configuration IEEE 802.11a Ant. 4-1 + Ant. 4-3 / 5300 MHz

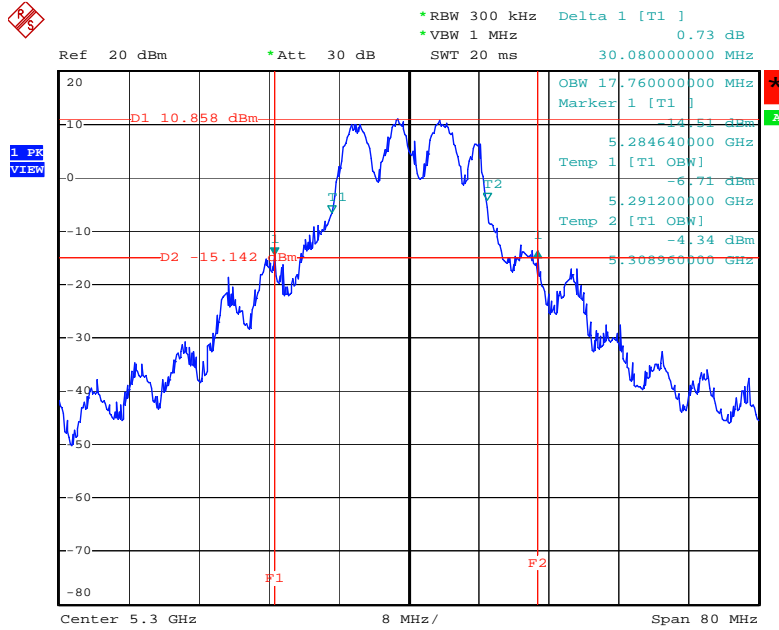

Date: 16.SEP.2009 17:45:23

26 dB Bandwidth Plot on Configuration IEEE 802.11a Ant. 4-1 + Ant. 4-3 / 5320 MHz

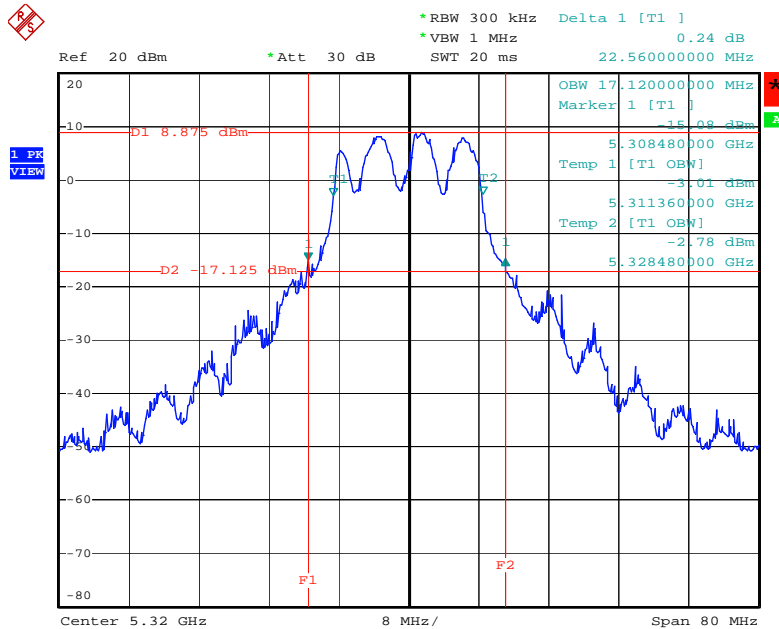

Date: 16.SEP.2009 17:49:03

26 dB Bandwidth Plot on Configuration IEEE 802.11a Ant. 4-1 + Ant. 4-3 / 5500 MHz

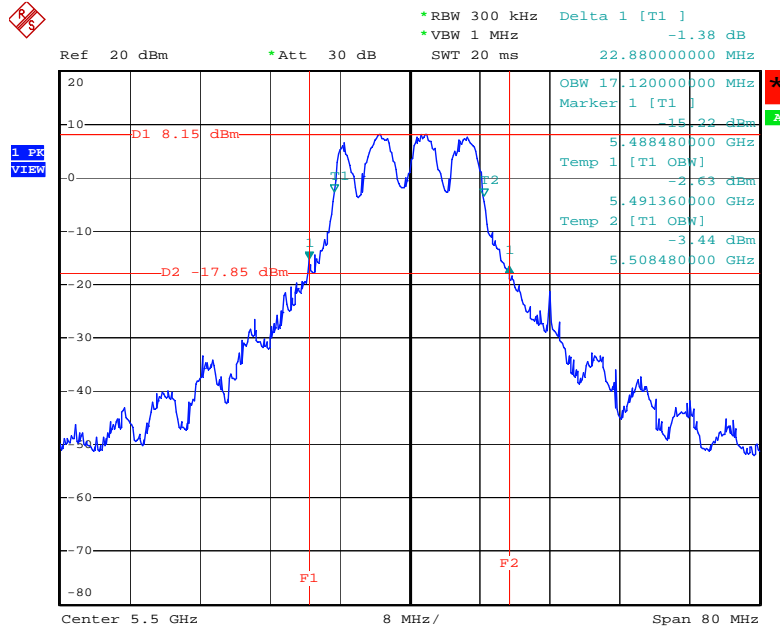

Date: 16.SEP.2009 17:54:13

26 dB Bandwidth Plot on Configuration IEEE 802.11a Ant. 4-1 + Ant. 4-3 / 5580 MHz

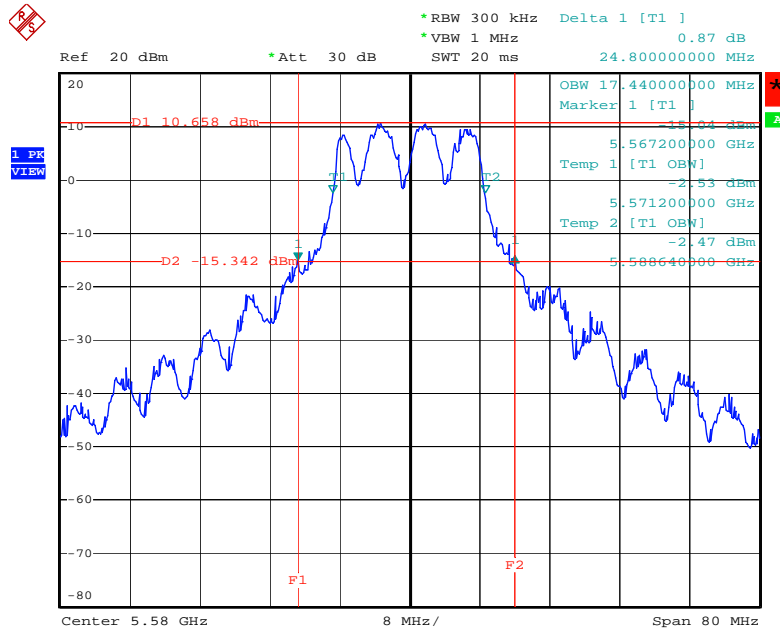

Date: 16.SEP.2009 17:57:19

26 dB Bandwidth Plot on Configuration IEEE 802.11a Ant. 4-1 + Ant. 4-3 / 5700 MHz

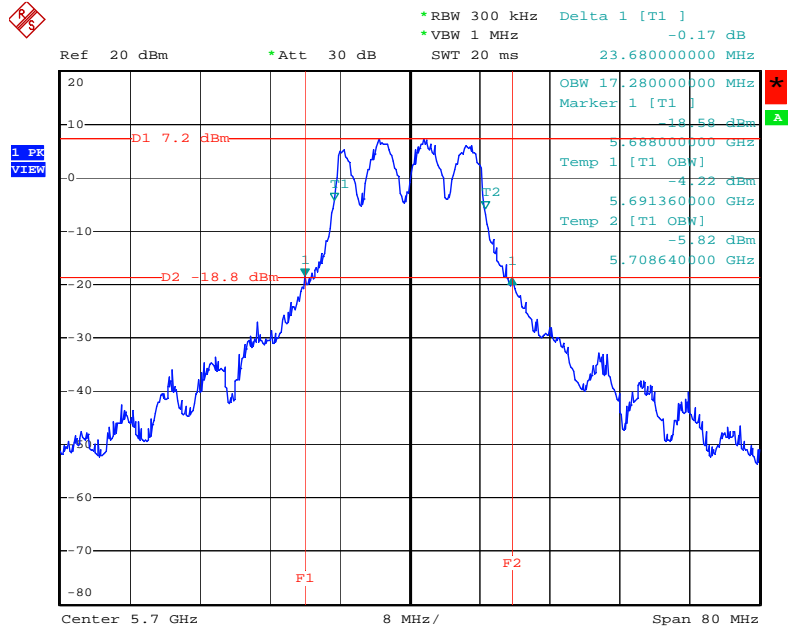

Date: 16.SEP.2009 18:01:59

<For Antenna 5>:

26 dB Bandwidth Plot on Configuration 802.11n MCS8 20MHz Ant. 5-1 + Ant. 5-3 / 5260 MHz

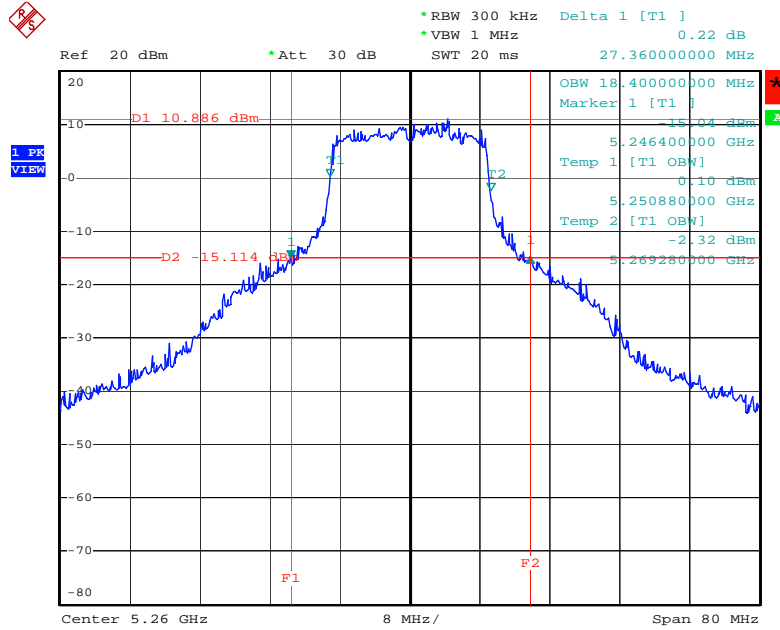

Date: 16.SEP.2009 18:24:50

26 dB Bandwidth Plot on Configuration 802.11n MCS8 20MHz Ant. 5-1 + Ant. 5-3 / 5300 MHz

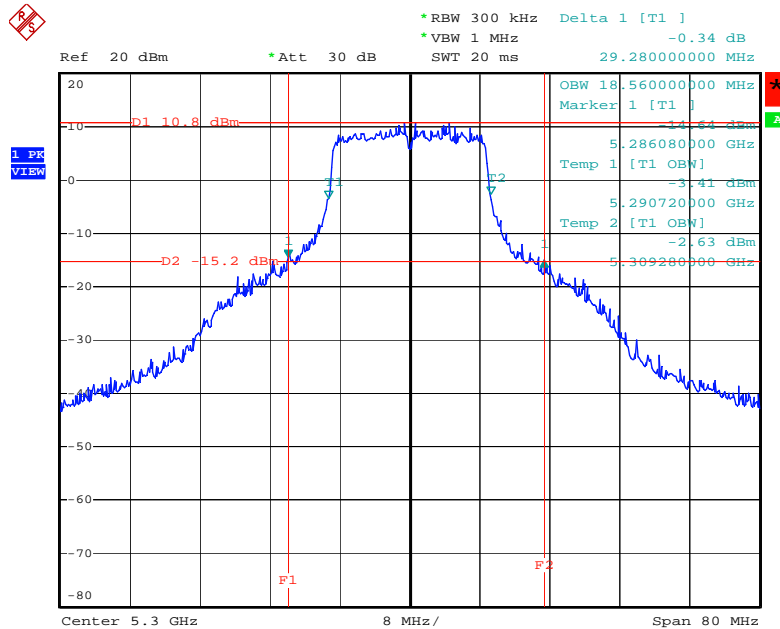

Date: 16.SEP.2009 18:27:52

26 dB Bandwidth Plot on Configuration 802.11n MCS8 20MHz Ant. 5-1 + Ant. 5-3 / 5320 MHz

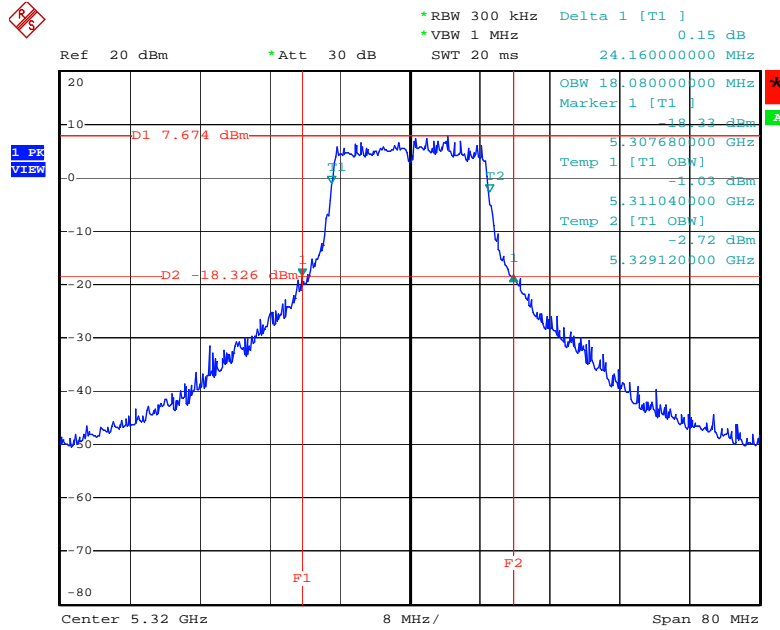

Date: 16.SEP.2009 18:29:46

26 dB Bandwidth Plot on Configuration 802.11n MCS8 20MHz Ant. 5-1 + Ant. 5-3 / 5500 MHz

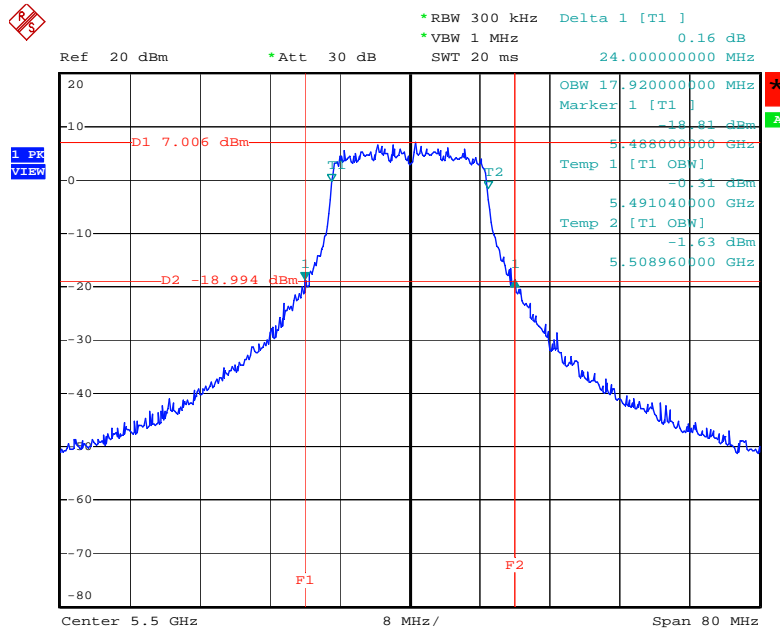

Date: 16.SEP.2009 18:37:13



26 dB Bandwidth Plot on Configuration 802.11n MCS8 20MHz Ant. 5-1 + Ant. 5-3 / 5580 MHz

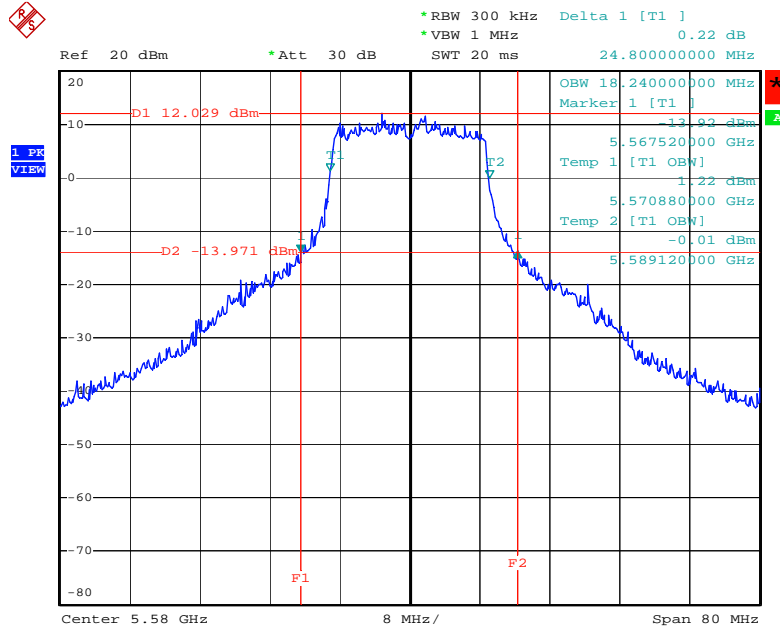

Date: 16.SEP.2009 18:38:45

26 dB Bandwidth Plot on Configuration 802.11n MCS8 20MHz Ant. 5-1 + Ant. 5-3 / 5700 MHz

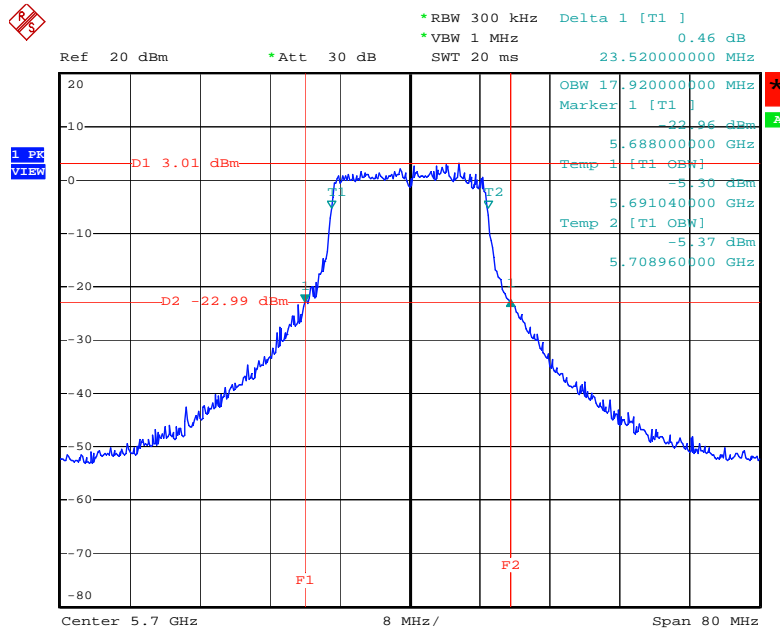

Date: 16.SEP.2009 18:45:54

26 dB Bandwidth Plot on Configuration 802.11n MCS8 40MHz Ant. 5-1 + Ant. 5-3 / 5270 MHz

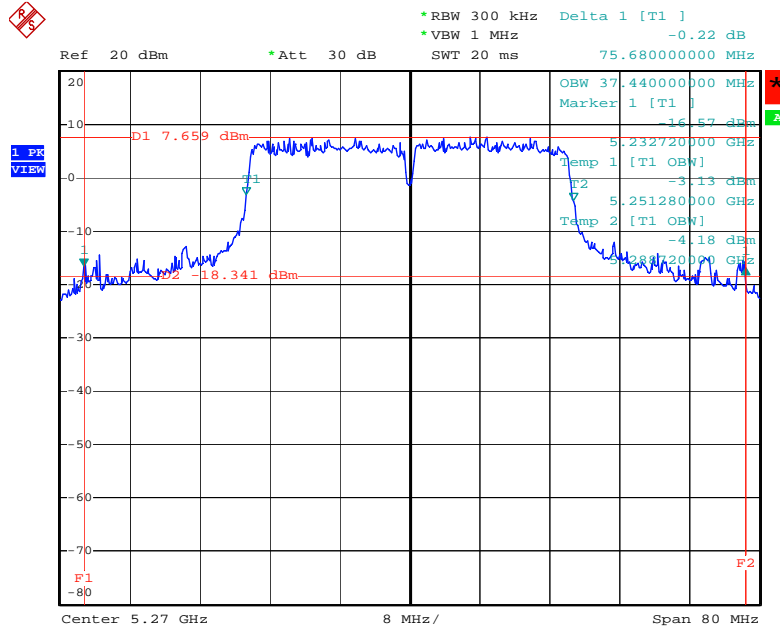

Date: 16.SEP.2009 18:52:27

26 dB Bandwidth Plot on Configuration 802.11n MCS8 40MHz Ant. 5-1 + Ant. 5-3 / 5310 MHz

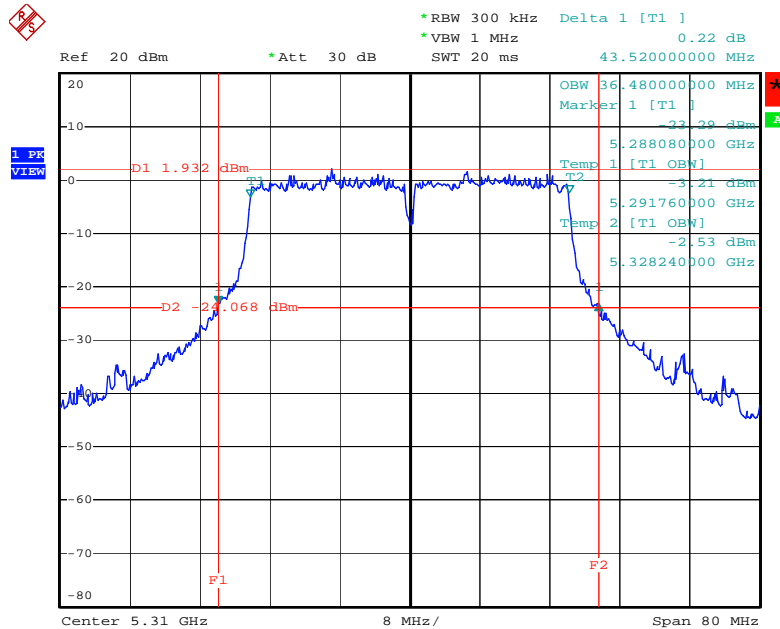

Date: 16.SEP.2009 18:59:11

26 dB Bandwidth Plot on Configuration 802.11n MCS8 40MHz Ant. 5-1 + Ant. 5-3 / 5510MHz

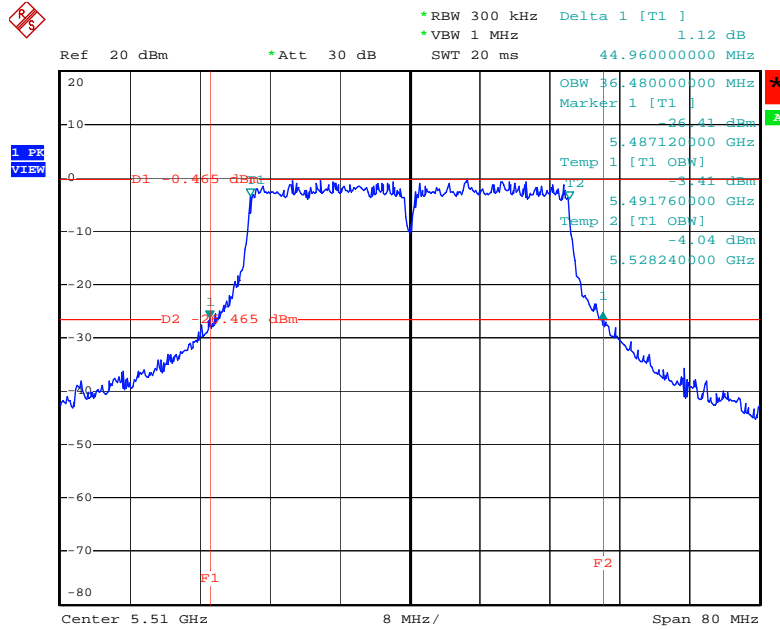

Date: 16.SEP.2009 19:03:32

26 dB Bandwidth Plot on Configuration 802.11n MCS8 40MHz Ant. 5-1 + Ant. 5-3 / 5550 MHz

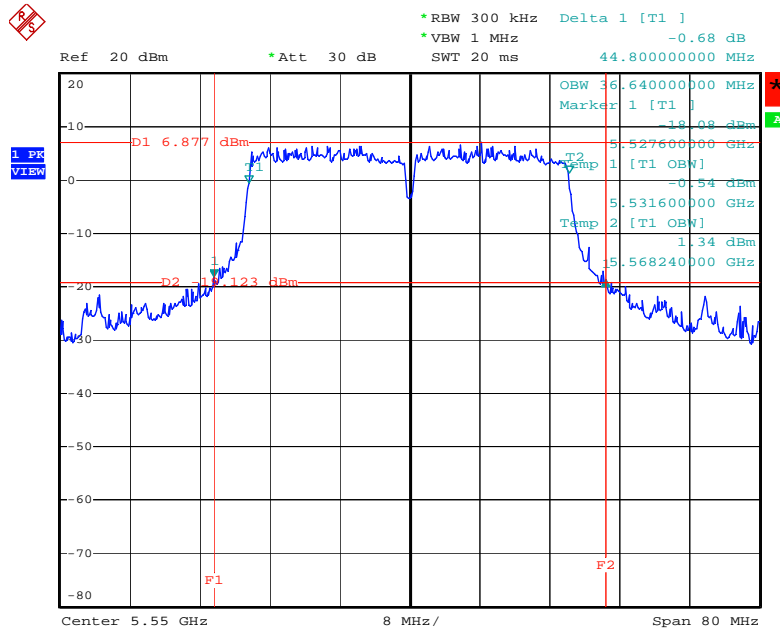

Date: 16.SEP.2009 19:11:38

26 dB Bandwidth Plot on Configuration 802.11n MCS8 40MHz Ant. 5-1 + Ant. 5-3 / 5670 MHz

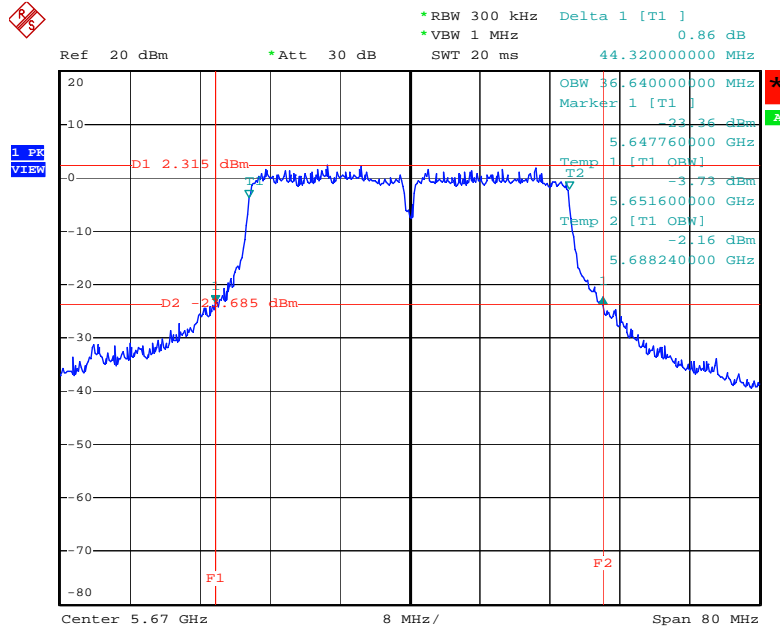

Date: 16.SEP.2009 19:16:14

26 dB Bandwidth Plot on Configuration IEEE 802.11a Ant. 5-1 + Ant. 5-3 / 5260 MHz

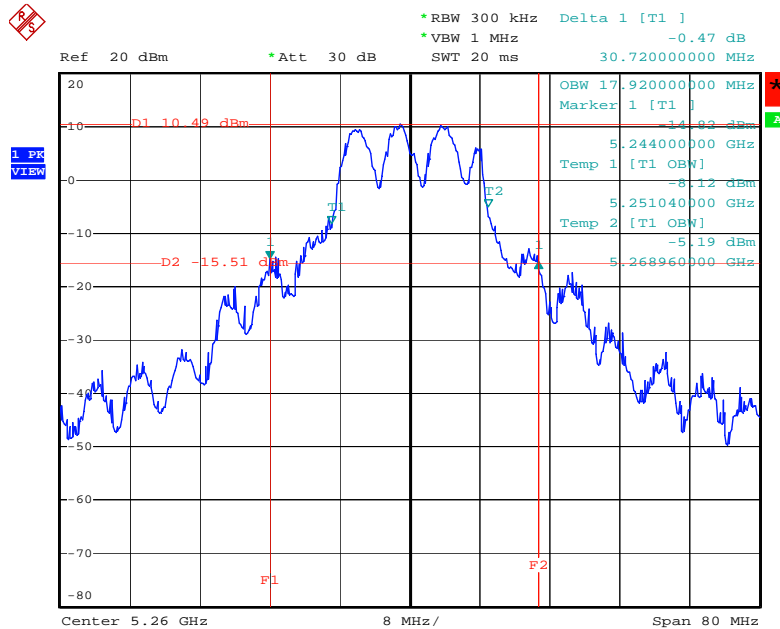

Date: 16.SEP.2009 17:41:54

26 dB Bandwidth Plot on Configuration IEEE 802.11a Ant. 5-1 + Ant. 5-3 / 5300 MHz

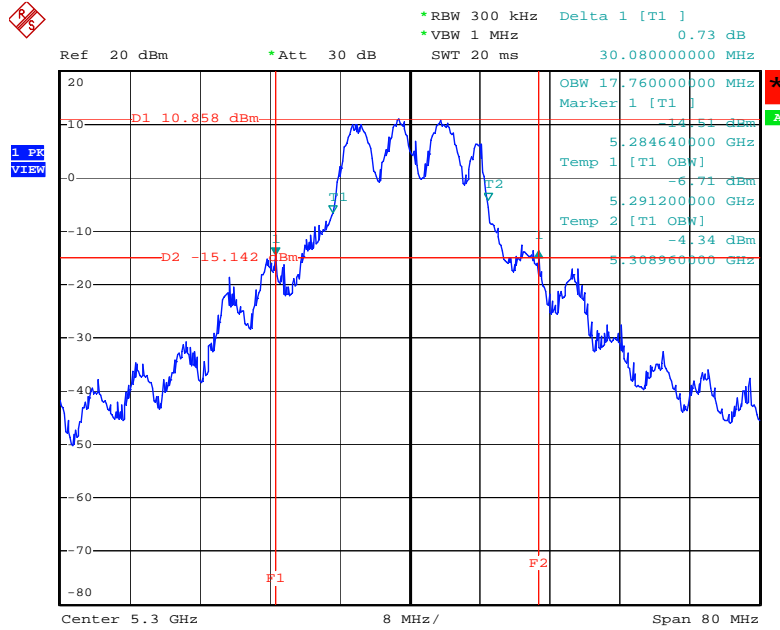

Date: 16.SEP.2009 17:45:23

26 dB Bandwidth Plot on Configuration IEEE 802.11a Ant. 5-1 + Ant. 5-3 / 5320 MHz

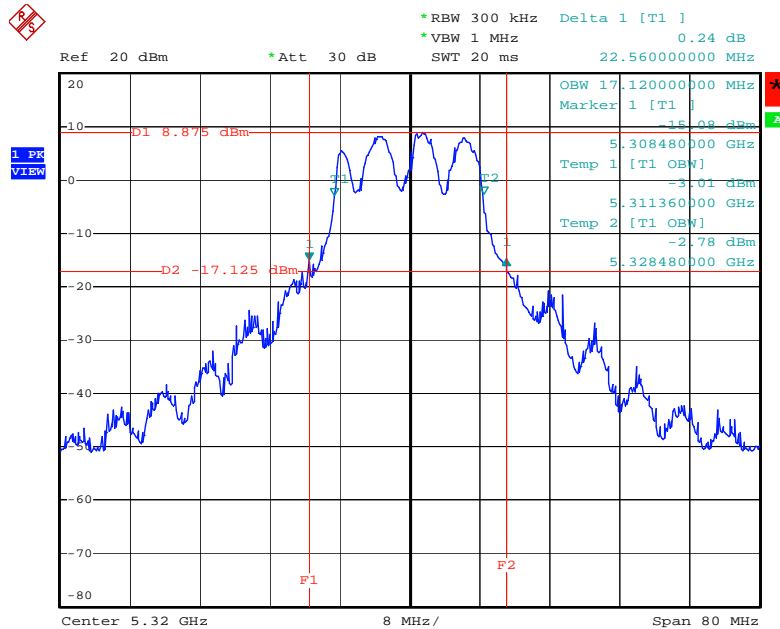

Date: 16.SEP.2009 17:49:03

26 dB Bandwidth Plot on Configuration IEEE 802.11a Ant. 5-1 + Ant. 5-3 / 5500 MHz

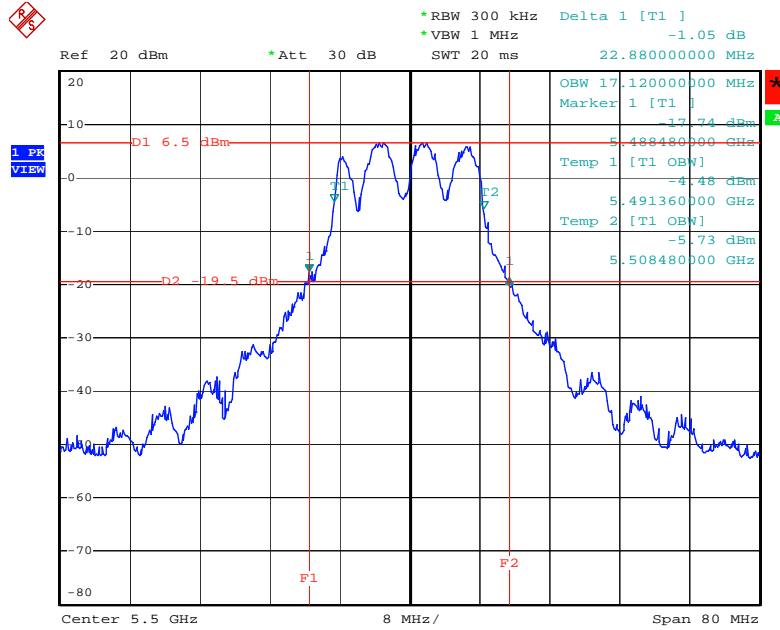

Date: 16.SEP.2009 17:55:06

26 dB Bandwidth Plot on Configuration IEEE 802.11a Ant. 5-1 + Ant. 5-3 / 5580 MHz

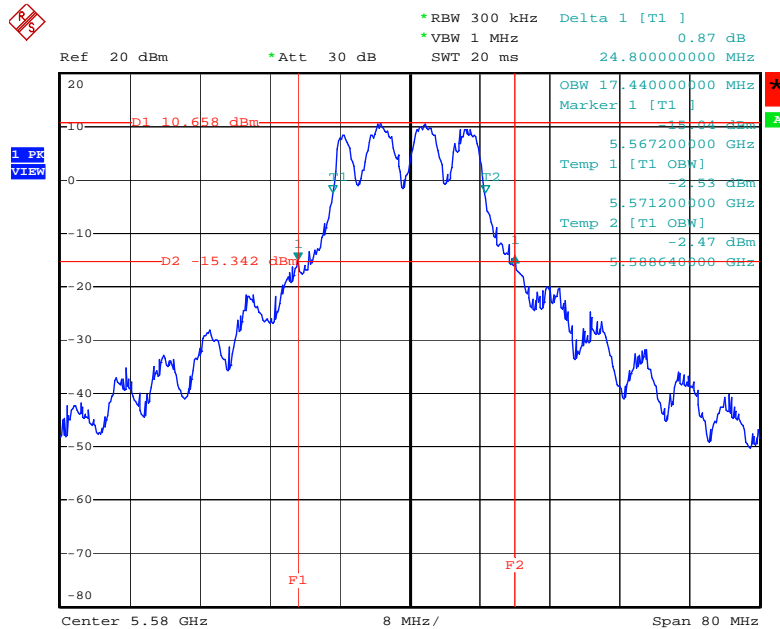

Date: 16.SEP.2009 17:57:19

26 dB Bandwidth Plot on Configuration IEEE 802.11a Ant. 5-1 + Ant. 5-3 / 5700 MHz

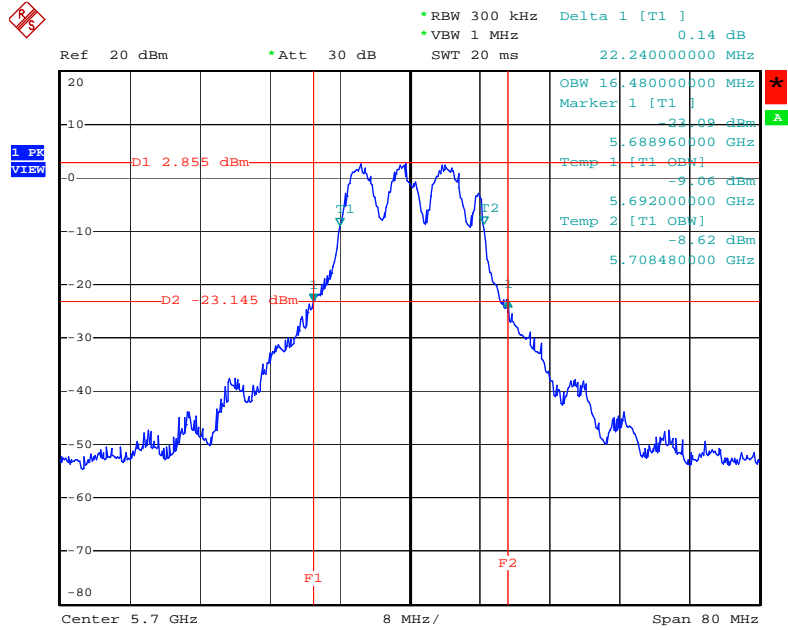

Date: 16.SEP.2009 18:02:55

<For Antenna 6>:

26 dB Bandwidth Plot on Configuration 802.11n MCS8 20MHz Ant. 6-1 + Ant. 6-3 / 5260 MHz

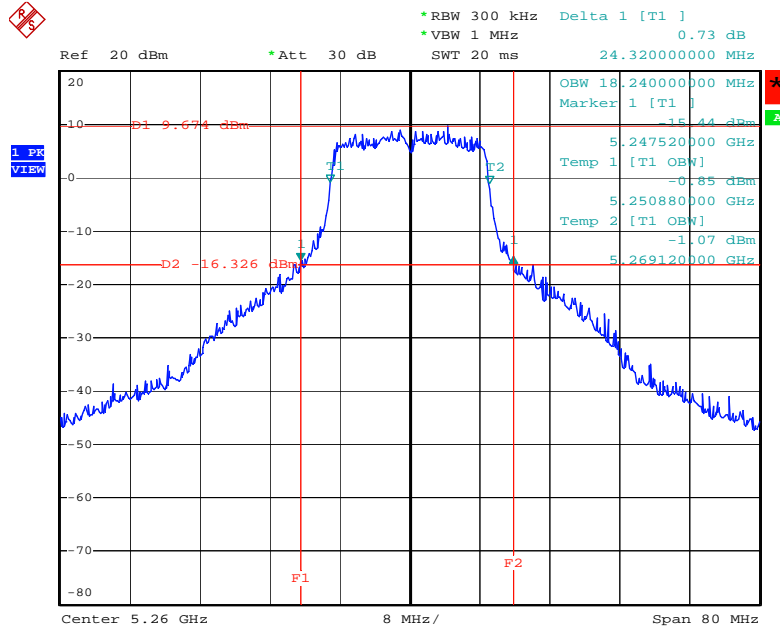

Date: 16.SEP.2009 18:23:36

26 dB Bandwidth Plot on Configuration 802.11n MCS8 20MHz Ant. 6-1 + Ant. 6-3 / 5300 MHz

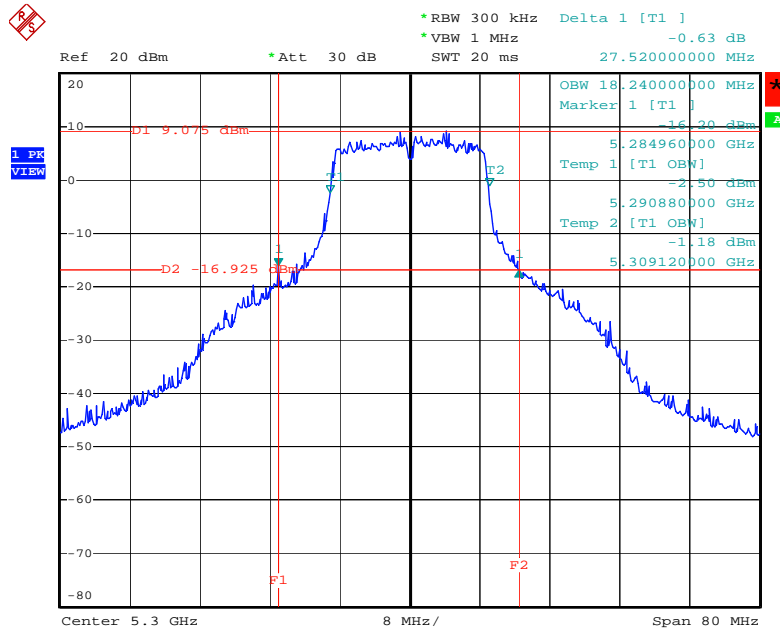

Date: 9.OCT.2009 18:36:46



26 dB Bandwidth Plot on Configuration 802.11n MCS8 20MHz Ant. 6-1 + Ant. 6-3 / 5320 MHz

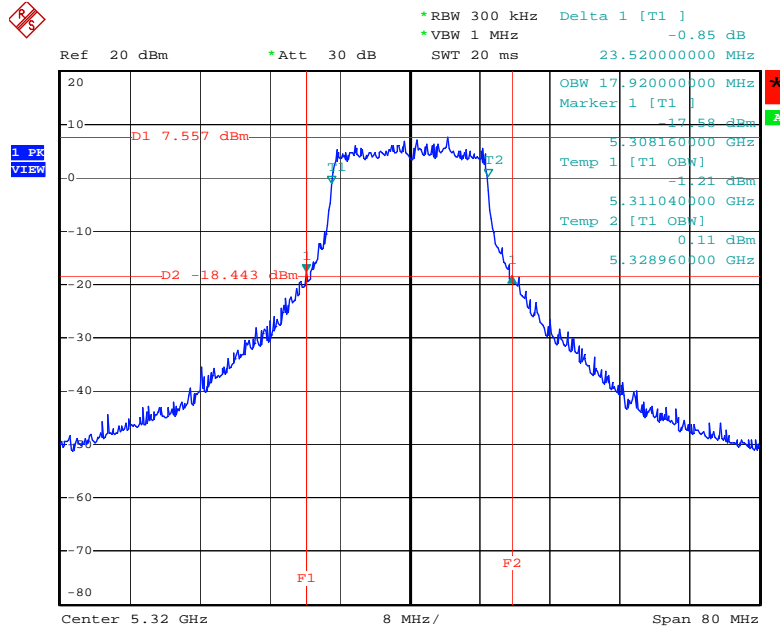

Date: 16.SEP.2009 18:31:39

26 dB Bandwidth Plot on Configuration 802.11n MCS8 20MHz Ant. 6-1 + Ant. 6-3 / 5500 MHz

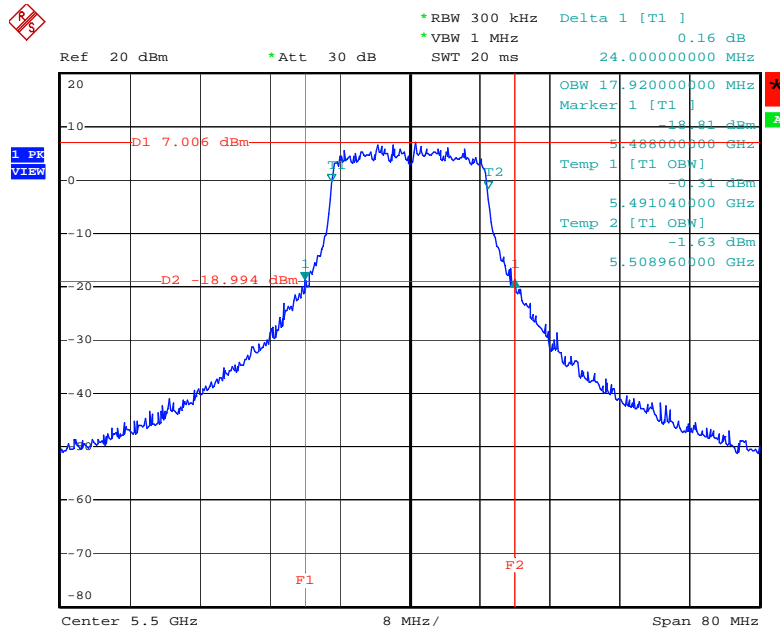

Date: 16.SEP.2009 18:37:13

26 dB Bandwidth Plot on Configuration 802.11n MCS8 20MHz Ant. 6-1 + Ant. 6-3 / 5580 MHz

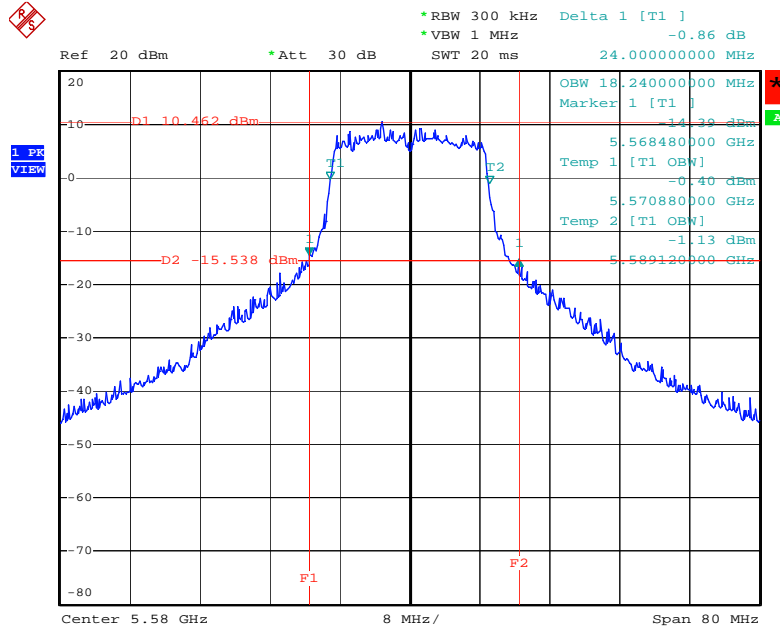

Date: 9.OCT.2009 17:29:21

26 dB Bandwidth Plot on Configuration 802.11n MCS8 20MHz Ant. 6-1 + Ant. 6-3 / 5700 MHz

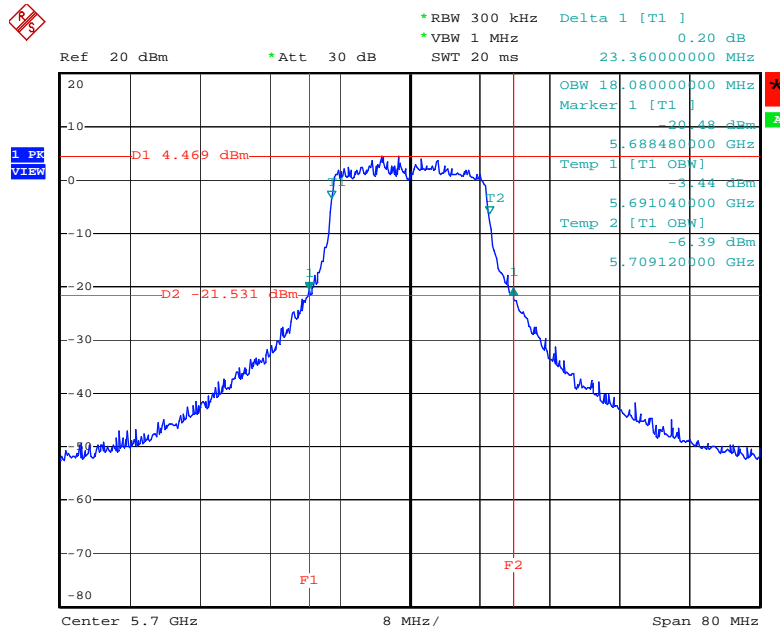

Date: 16.SEP.2009 18:43:09

26 dB Bandwidth Plot on Configuration 802.11n MCS8 40MHz Ant. 6-1 + Ant. 6-3 / 5270 MHz

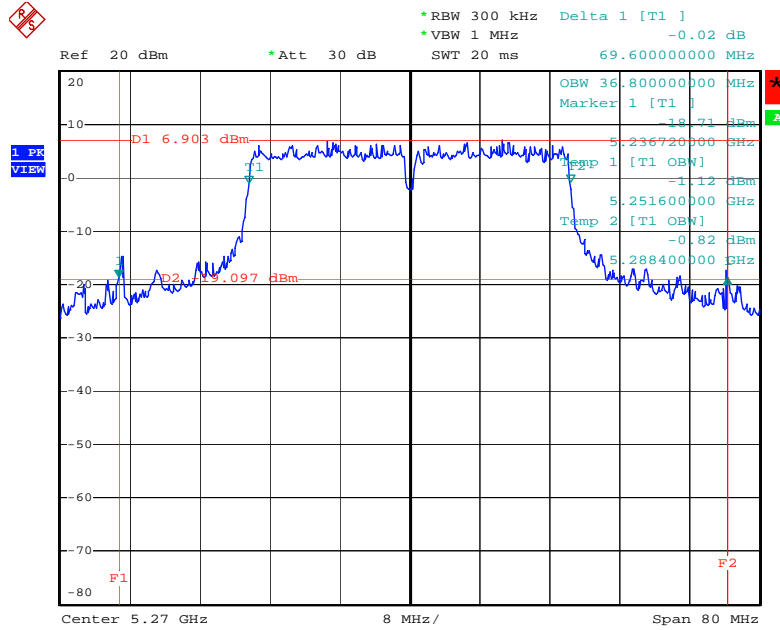

Date: 16.SEP.2009 18:53:40

26 dB Bandwidth Plot on Configuration 802.11n MCS8 40MHz Ant. 6-1 + Ant. 6-3 / 5310 MHz

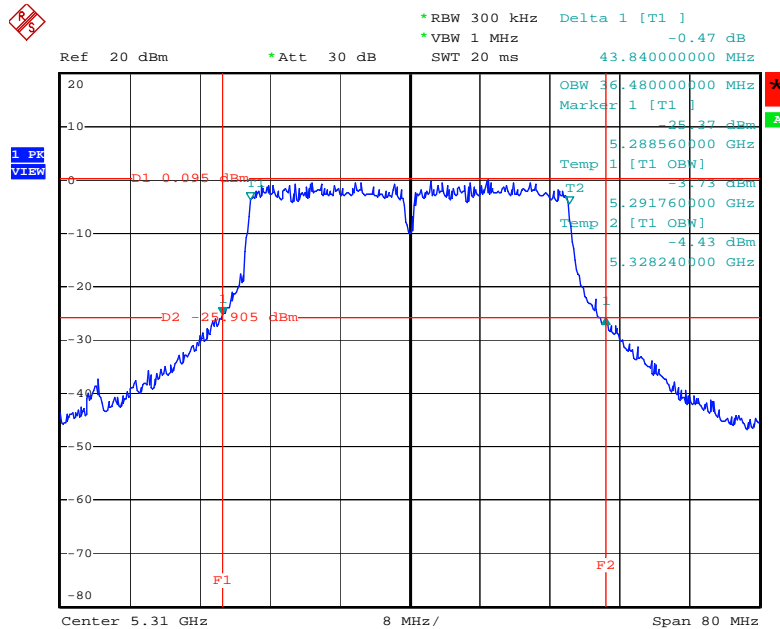

Date: 16.SEP.2009 19:00:02

26 dB Bandwidth Plot on Configuration 802.11n MCS8 40MHz Ant. 6-1 + Ant. 6-3 / 5510MHz

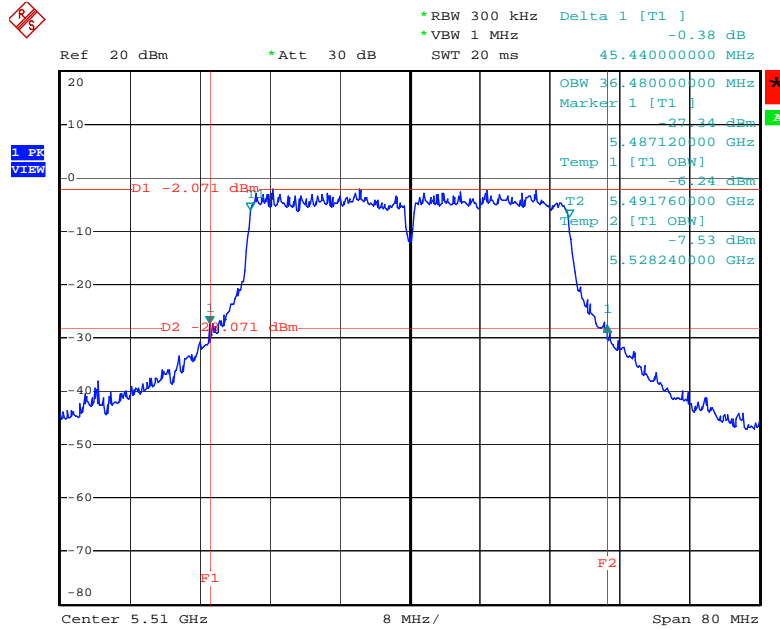

Date: 16.SEP.2009 19:09:05

26 dB Bandwidth Plot on Configuration 802.11n MCS8 40MHz Ant. 6-1 + Ant. 6-3 / 5550 MHz

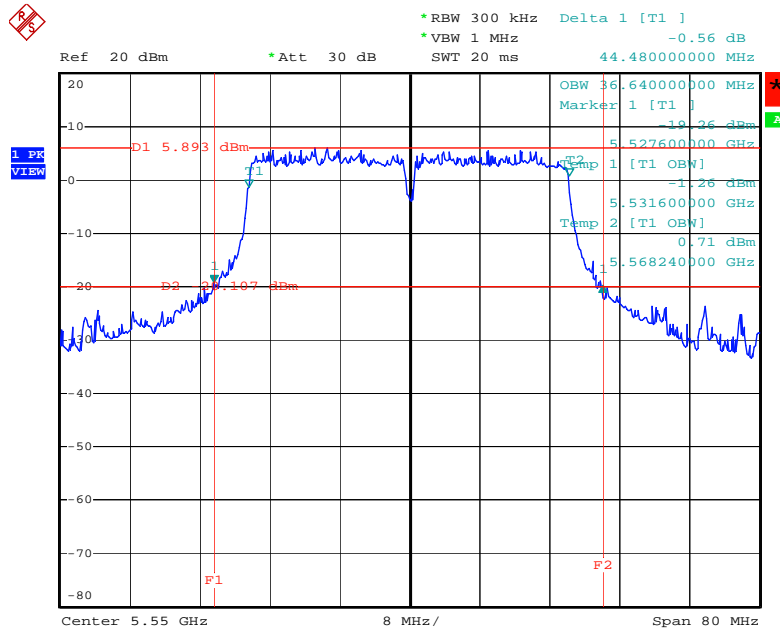

Date: 16.SEP.2009 19:12:26

26 dB Bandwidth Plot on Configuration 802.11n MCS8 40MHz Ant. 6-1 + Ant. 6-3 / 5670 MHz

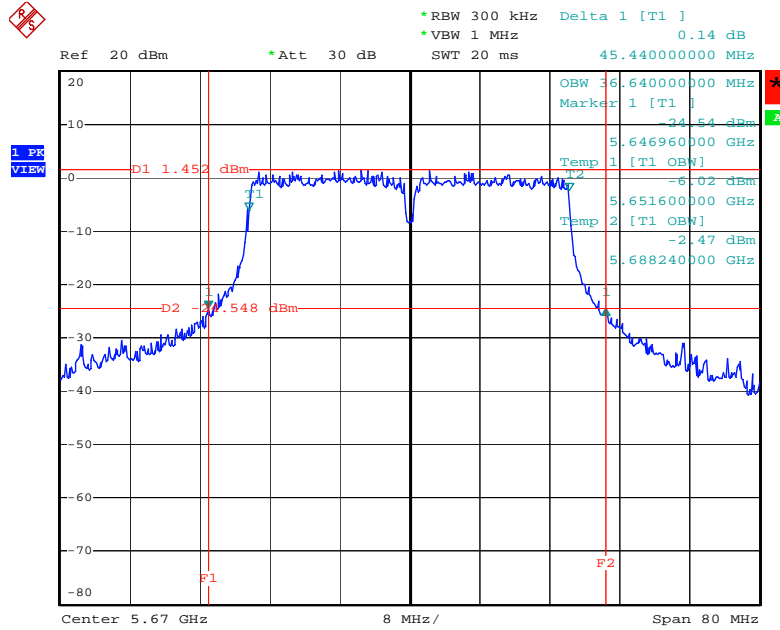

Date: 16.SEP.2009 19:16:59

26 dB Bandwidth Plot on Configuration IEEE 802.11a Ant. 6-1 + Ant. 6-3 / 5260 MHz

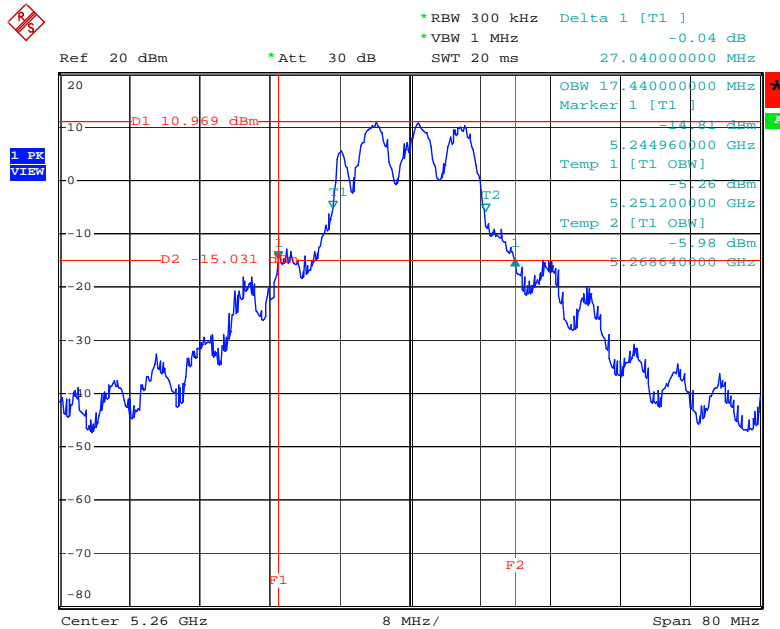

Date: 16.SEP.2009 22:49:09

26 dB Bandwidth Plot on Configuration IEEE 802.11a Ant. 6-1 + Ant. 6-3 / 5300 MHz

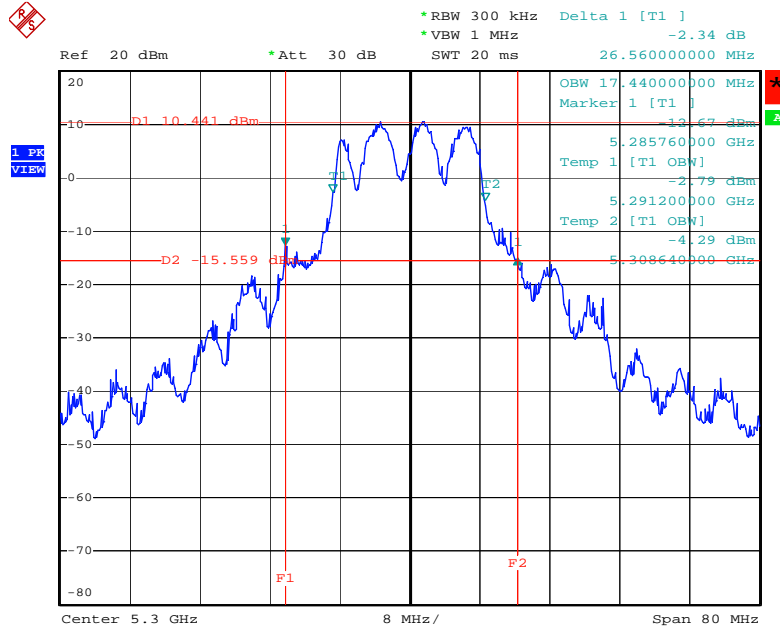

Date: 16.SEP.2009 17:42:47

26 dB Bandwidth Plot on Configuration IEEE 802.11a Ant. 6-1 + Ant. 6-3 / 5320 MHz

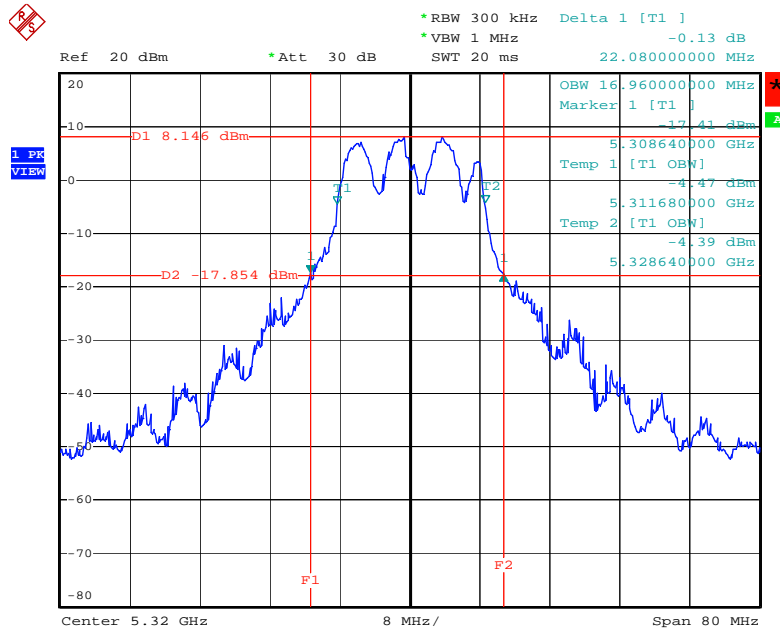

Date: 16.SEP.2009 17:50:09



### 26 dB Bandwidth Plot on Configuration IEEE 802.11a Ant. 6-1 + Ant. 6-3 / 5500 MHz

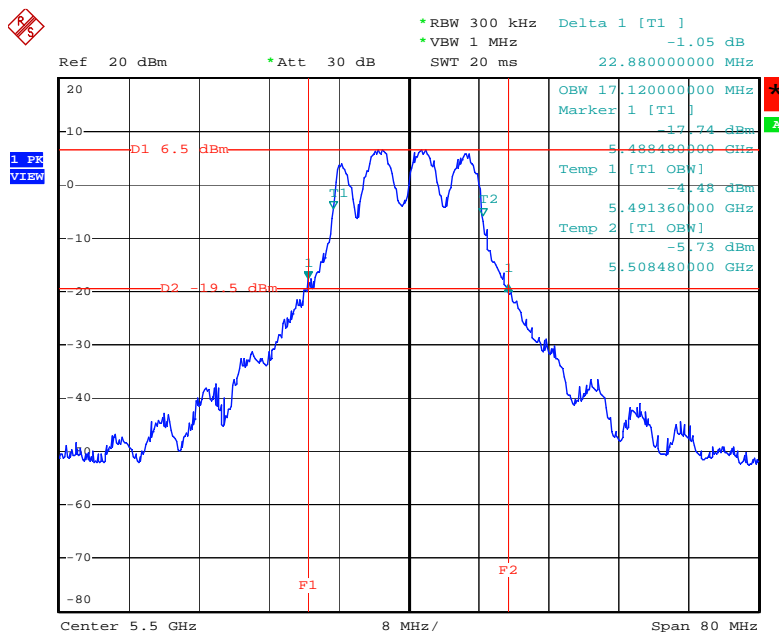

Date: 16.SEP.2009 17:55:06

### 26 dB Bandwidth Plot on Configuration IEEE 802.11a Ant. 6-1 + Ant. 6-3 / 5580 MHz

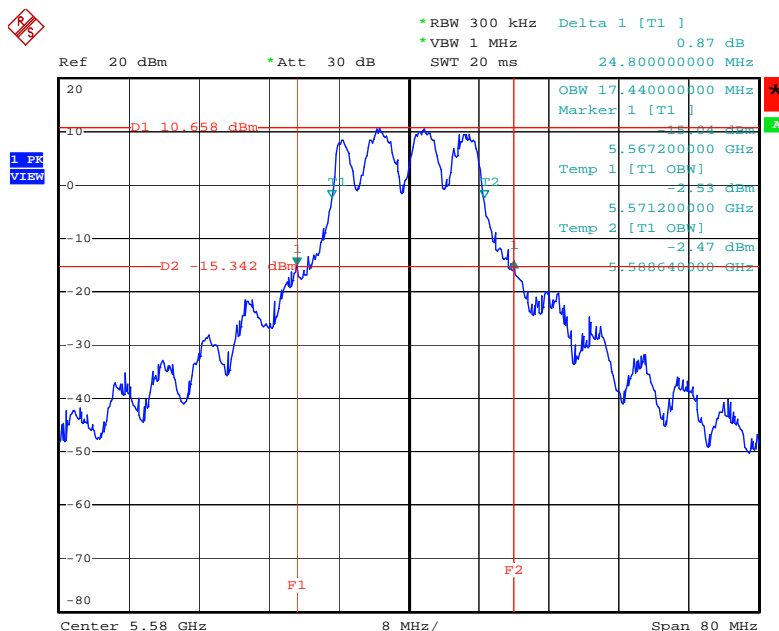

Date: 16.SEP.2009 17:57:19

26 dB Bandwidth Plot on Configuration IEEE 802.11a Ant. 6-1 + Ant. 6-3 / 5700 MHz

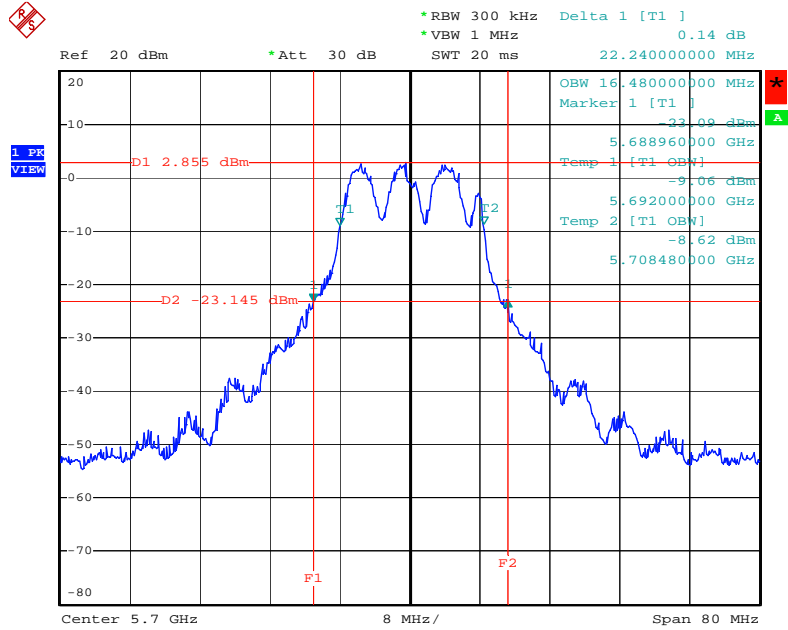

Date: 16.SEP.2009 18:02:55



### 4.3. Maximum Conducted Output Power Measurement

#### 4.3.1. Limit

For the 5.25-5.35 GHz and 5.470-5.725 GHz bands, the maximum conducted output power over the frequency bands of operation shall not exceed the lesser of 250 mW (24dBm) or  $11 \text{ dBm} + 10\log B$ . If transmitting antennas of directional gain greater than 6 dBi are used, the peak output power and power density from the intentional radiator shall be reduced by the amount in dB that the directional gain of the antenna exceeds 6 dBi.

However, fixed point-to-point U-NII devices operating in this band may employ transmitting antennas with directional gain up to 23 dBi without any corresponding reduction in the transmitter peak output power and peak power spectral density. For fixed, point-to-point U-NII transmitters that employ a directional antenna gain greater than 23 dBi, a 1 dB reduction in peak transmitter power and peak power spectral density for each 1 dB of antenna gain in excess of 23 dBi would be required.

#### 4.3.2. Measuring Instruments and Setting

Please refer to section 5 of equipments list in this report. The following table is the setting of the spectrum analyzer.

Spectrum Parameter	Setting
Attenuation	Auto
Span Frequency	Encompass the entire emissions bandwidth (EBW) of the signal
RB	1000 kHz
VB	3000 kHz
Detector	RMS
Trace	MAX HOLD
Sweep Time	Auto

#### 4.3.3. Test Procedures

1. The transmitter output (antenna port) was connected to the spectrum analyzer.
2. Test was performed in accordance with FCC Public Notice DA 02-2138, August 30, 2002.
3. When measuring maximum conducted output power with multiple antenna systems, add every result of the values by mathematic formula.

#### 4.3.4. Test Setup Layout

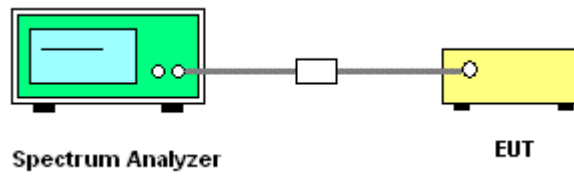

#### 4.3.5. Test Deviation

There is no deviation with the original standard.

#### 4.3.6. EUT Operation during Test

The EUT was programmed to be in continuously transmitting mode.

#### 4.3.7. Test Result of Maximum Conducted Output Power

<For Antenna 1>:

<b>Temperature</b>	21°C	<b>Humidity</b>	56%
<b>Test Engineer</b>	Johnson Chang	<b>Configurations</b>	802.11n / Antenna 1

##### Configuration 802.11n MCS8 20MHz Ant. 1-1

Channel	Frequency	Conducted Power (dBm)	Max. Limit (dBm)	Result
52	5260 MHz	19.09	23.00	Complies
60	5300 MHz	18.86	23.00	Complies
64	5320 MHz	16.49	23.00	Complies
100	5500 MHz	13.74	23.00	Complies
116	5580 MHz	18.80	23.00	Complies
140	5700 MHz	13.76	23.00	Complies

##### Configuration 802.11n MCS8 20MHz Ant. 1-3

Channel	Frequency	Conducted Power (dBm)	Max. Limit (dBm)	Result
52	5260 MHz	19.23	23.00	Complies
60	5300 MHz	19.24	23.00	Complies
64	5320 MHz	17.28	23.00	Complies
100	5500 MHz	13.91	23.00	Complies
116	5580 MHz	20.21	23.00	Complies
140	5700 MHz	14.66	23.00	Complies

##### Configuration 802.11n MCS8 20MHz Ant. 1-1 + Ant. 1-3

Channel	Frequency	Conducted Power (dBm)	Max. Limit (dBm)	Result
52	5260 MHz	22.17	23.00	Complies
60	5300 MHz	22.06	23.00	Complies
64	5320 MHz	19.91	23.00	Complies
100	5500 MHz	16.84	23.00	Complies
116	5580 MHz	22.57	23.00	Complies
140	5700 MHz	17.24	23.00	Complies

**Configuration 802.11n MCS8 40MHz Ant. 1-1**

Channel	Frequency	Conducted Power (dBm)	Max. Limit (dBm)	Result
54	5270 MHz	18.41	23.00	Complies
62	5310 MHz	13.16	23.00	Complies
102	5510MHz	11.25	23.00	Complies
110	5550 MHz	18.24	23.00	Complies
134	5670 MHz	15.45	23.00	Complies

**Configuration 802.11n MCS8 40MHz Ant. 1-3**

Channel	Frequency	Conducted Power (dBm)	Max. Limit (dBm)	Result
54	5270 MHz	19.51	23.00	Complies
62	5310 MHz	14.04	23.00	Complies
102	5510MHz	11.17	23.00	Complies
110	5550 MHz	20.60	23.00	Complies
134	5670 MHz	16.05	23.00	Complies

**Configuration 802.11n MCS8 40MHz Ant. 1-1 + Ant. 1-3**

Channel	Frequency	Conducted Power (dBm)	Max. Limit (dBm)	Result
54	5270 MHz	22.01	23.00	Complies
62	5310 MHz	16.63	23.00	Complies
102	5510MHz	14.22	23.00	Complies
110	5550 MHz	22.59	23.00	Complies
134	5670 MHz	18.77	23.00	Complies

<b>Temperature</b>	21°C	<b>Humidity</b>	56%
<b>Test Engineer</b>	Johnson Chang	<b>Configurations</b>	802.11a / Antenna 1

**Configuration IEEE 802.11a Ant. 1-1**

Channel	Frequency	Conducted Power (dBm)	Max. Limit (dBm)	Result
52	5260 MHz	18.91	23.00	Complies
60	5300 MHz	18.81	23.00	Complies
64	5320 MHz	16.30	23.00	Complies
100	5500 MHz	13.00	23.00	Complies
116	5580 MHz	18.78	23.00	Complies
140	5700 MHz	13.55	23.00	Complies

**Configuration IEEE 802.11a Ant. 1-3**

Channel	Frequency	Conducted Power (dBm)	Max. Limit (dBm)	Result
52	5260 MHz	19.01	23.00	Complies
60	5300 MHz	18.97	23.00	Complies
64	5320 MHz	17.23	23.00	Complies
100	5500 MHz	13.28	23.00	Complies
116	5580 MHz	20.19	23.00	Complies
140	5700 MHz	14.49	23.00	Complies

**Configuration IEEE 802.11a Ant. 1-1 + Ant. 1-3**

Channel	Frequency	Conducted Power (dBm)	Max. Limit (dBm)	Result
52	5260 MHz	21.97	23.00	Complies
60	5300 MHz	21.90	23.00	Complies
64	5320 MHz	19.80	23.00	Complies
100	5500 MHz	16.15	23.00	Complies
116	5580 MHz	22.55	23.00	Complies
140	5700 MHz	17.06	23.00	Complies

<For Antenna 2>:

<b>Temperature</b>	21°C	<b>Humidity</b>	56%
<b>Test Engineer</b>	Johnson Chang	<b>Configurations</b>	802.11n / Antenna 2

**Configuration 802.11n MCS8 20MHz Ant. 2-1**

Channel	Frequency	Conducted Power (dBm)	Max. Limit (dBm)	Result
52	5260 MHz	19.78	24.00	Complies
60	5300 MHz	17.55	24.00	Complies
64	5320 MHz	17.56	24.00	Complies
100	5500 MHz	18.98	24.00	Complies
116	5580 MHz	19.46	24.00	Complies
140	5700 MHz	18.14	24.00	Complies

**Configuration 802.11n MCS8 20MHz Ant. 2-3**

Channel	Frequency	Conducted Power (dBm)	Max. Limit (dBm)	Result
52	5260 MHz	20.66	24.00	Complies
60	5300 MHz	18.31	24.00	Complies
64	5320 MHz	18.67	24.00	Complies
100	5500 MHz	20.44	24.00	Complies
116	5580 MHz	20.93	24.00	Complies
140	5700 MHz	18.46	24.00	Complies

**Configuration 802.11n MCS8 20MHz Ant. 2-1 + Ant. 2-3**

Channel	Frequency	Conducted Power (dBm)	Max. Limit (dBm)	Result
52	5260 MHz	23.25	24.00	Complies
60	5300 MHz	20.96	24.00	Complies
64	5320 MHz	21.16	24.00	Complies
100	5500 MHz	22.78	24.00	Complies
116	5580 MHz	23.27	24.00	Complies
140	5700 MHz	21.31	24.00	Complies

**Configuration 802.11n MCS8 40MHz Ant. 2-1**

Channel	Frequency	Conducted Power (dBm)	Max. Limit (dBm)	Result
54	5270 MHz	20.16	24.00	Complies
62	5310 MHz	16.03	24.00	Complies
102	5510MHz	15.81	24.00	Complies
110	5550 MHz	19.24	24.00	Complies
134	5670 MHz	20.00	24.00	Complies

**Configuration 802.11n MCS8 40MHz Ant. 2-3**

Channel	Frequency	Conducted Power (dBm)	Max. Limit (dBm)	Result
54	5270 MHz	20.96	24.00	Complies
62	5310 MHz	16.18	24.00	Complies
102	5510MHz	17.43	24.00	Complies
110	5550 MHz	20.64	24.00	Complies
134	5670 MHz	20.88	24.00	Complies

**Configuration 802.11n MCS8 40MHz Ant. 2-1 + Ant. 2-3**

Channel	Frequency	Conducted Power (dBm)	Max. Limit (dBm)	Result
54	5270 MHz	23.59	24.00	Complies
62	5310 MHz	19.12	24.00	Complies
102	5510MHz	19.71	24.00	Complies
110	5550 MHz	23.01	24.00	Complies
134	5670 MHz	23.47	24.00	Complies

<b>Temperature</b>	21°C	<b>Humidity</b>	56%
<b>Test Engineer</b>	Johnson Chang	<b>Configurations</b>	802.11a / Antenna 2

**Configuration IEEE 802.11a Ant. 2-1**

Channel	Frequency	Conducted Power (dBm)	Max. Limit (dBm)	Result
52	5260 MHz	19.24	24.00	Complies
60	5300 MHz	16.53	24.00	Complies
64	5320 MHz	16.30	24.00	Complies
100	5500 MHz	18.48	24.00	Complies
116	5580 MHz	18.78	24.00	Complies
140	5700 MHz	17.47	24.00	Complies

**Configuration IEEE 802.11a Ant. 2-3**

Channel	Frequency	Conducted Power (dBm)	Max. Limit (dBm)	Result
52	5260 MHz	19.88	24.00	Complies
60	5300 MHz	17.17	24.00	Complies
64	5320 MHz	17.23	24.00	Complies
100	5500 MHz	19.16	24.00	Complies
116	5580 MHz	20.19	24.00	Complies
140	5700 MHz	17.56	24.00	Complies

**Configuration IEEE 802.11a Ant. 2-1 + Ant. 2-3**

Channel	Frequency	Conducted Power (dBm)	Max. Limit (dBm)	Result
52	5260 MHz	22.58	24.00	Complies
60	5300 MHz	19.87	24.00	Complies
64	5320 MHz	19.80	24.00	Complies
100	5500 MHz	21.84	24.00	Complies
116	5580 MHz	22.55	24.00	Complies
140	5700 MHz	20.53	24.00	Complies



<For Antenna 3>:

<b>Temperature</b>	21°C	<b>Humidity</b>	56%
<b>Test Engineer</b>	Johnson Chang	<b>Configurations</b>	802.11n / Antenna 3

**Configuration 802.11n MCS8 20MHz Ant. 3-1**

Channel	Frequency	Conducted Power (dBm)	Max. Limit (dBm)	Result
52	5260 MHz	19.78	24.00	Complies
60	5300 MHz	19.32	24.00	Complies
64	5320 MHz	17.56	24.00	Complies
100	5500 MHz	16.44	24.00	Complies
116	5580 MHz	19.46	24.00	Complies
140	5700 MHz	15.56	24.00	Complies

**Configuration 802.11n MCS8 20MHz Ant. 3-3**

Channel	Frequency	Conducted Power (dBm)	Max. Limit (dBm)	Result
52	5260 MHz	20.66	24.00	Complies
60	5300 MHz	20.77	24.00	Complies
64	5320 MHz	18.67	24.00	Complies
100	5500 MHz	17.43	24.00	Complies
116	5580 MHz	20.93	24.00	Complies
140	5700 MHz	16.17	24.00	Complies

**Configuration 802.11n MCS8 20MHz Ant. 3-1 + Ant. 3-3**

Channel	Frequency	Conducted Power (dBm)	Max. Limit (dBm)	Result
52	5260 MHz	23.25	24.00	Complies
60	5300 MHz	23.12	24.00	Complies
64	5320 MHz	21.16	24.00	Complies
100	5500 MHz	19.97	24.00	Complies
116	5580 MHz	23.27	24.00	Complies
140	5700 MHz	18.89	24.00	Complies

**Configuration 802.11n MCS8 40MHz Ant. 3-1**

Channel	Frequency	Conducted Power (dBm)	Max. Limit (dBm)	Result
54	5270 MHz	20.16	24.00	Complies
62	5310 MHz	15.34	24.00	Complies
102	5510MHz	12.54	24.00	Complies
110	5550 MHz	19.24	24.00	Complies
134	5670 MHz	16.87	24.00	Complies

**Configuration 802.11n MCS8 40MHz Ant. 3-3**

Channel	Frequency	Conducted Power (dBm)	Max. Limit (dBm)	Result
54	5270 MHz	20.96	24.00	Complies
62	5310 MHz	15.73	24.00	Complies
102	5510MHz	13.38	24.00	Complies
110	5550 MHz	20.64	24.00	Complies
134	5670 MHz	17.25	24.00	Complies

**Configuration 802.11n MCS8 40MHz Ant. 3-1 + Ant. 3-3**

Channel	Frequency	Conducted Power (dBm)	Max. Limit (dBm)	Result
54	5270 MHz	23.59	24.00	Complies
62	5310 MHz	18.55	24.00	Complies
102	5510MHz	15.99	24.00	Complies
110	5550 MHz	23.01	24.00	Complies
134	5670 MHz	20.07	24.00	Complies

<b>Temperature</b>	21°C	<b>Humidity</b>	56%
<b>Test Engineer</b>	Johnson Chang	<b>Configurations</b>	802.11a / Antenna 3

**Configuration IEEE 802.11a Ant. 3-1**

Channel	Frequency	Conducted Power (dBm)	Max. Limit (dBm)	Result
52	5260 MHz	19.24	24.00	Complies
60	5300 MHz	19.52	24.00	Complies
64	5320 MHz	17.42	24.00	Complies
100	5500 MHz	16.54	24.00	Complies
116	5580 MHz	18.78	24.00	Complies
140	5700 MHz	16.03	24.00	Complies

**Configuration IEEE 802.11a Ant. 3-3**

Channel	Frequency	Conducted Power (dBm)	Max. Limit (dBm)	Result
52	5260 MHz	19.88	24.00	Complies
60	5300 MHz	20.07	24.00	Complies
64	5320 MHz	18.59	24.00	Complies
100	5500 MHz	17.29	24.00	Complies
116	5580 MHz	20.19	24.00	Complies
140	5700 MHz	16.04	24.00	Complies

**Configuration IEEE 802.11a Ant. 3-1 + Ant. 3-3**

Channel	Frequency	Conducted Power (dBm)	Max. Limit (dBm)	Result
52	5260 MHz	22.58	24.00	Complies
60	5300 MHz	22.81	24.00	Complies
64	5320 MHz	21.05	24.00	Complies
100	5500 MHz	19.94	24.00	Complies
116	5580 MHz	22.55	24.00	Complies
140	5700 MHz	19.05	24.00	Complies

<For Antenna 4>:

<b>Temperature</b>	21°C	<b>Humidity</b>	56%
<b>Test Engineer</b>	Johnson Chang	<b>Configurations</b>	802.11n / Antenna 4

**Configuration 802.11n MCS8 20MHz Ant. 4-1**

Channel	Frequency	Conducted Power (dBm)	Max. Limit (dBm)	Result
52	5260 MHz	19.78	24.00	Complies
60	5300 MHz	19.32	24.00	Complies
64	5320 MHz	17.56	24.00	Complies
100	5500 MHz	15.82	24.00	Complies
116	5580 MHz	19.46	24.00	Complies
140	5700 MHz	13.76	24.00	Complies

**Configuration 802.11n MCS8 20MHz Ant. 4-3**

Channel	Frequency	Conducted Power (dBm)	Max. Limit (dBm)	Result
52	5260 MHz	20.66	24.00	Complies
60	5300 MHz	20.77	24.00	Complies
64	5320 MHz	18.67	24.00	Complies
100	5500 MHz	16.48	24.00	Complies
116	5580 MHz	20.93	24.00	Complies
140	5700 MHz	14.66	24.00	Complies

**Configuration 802.11n MCS8 20MHz Ant. 4-1 + Ant. 4-3**

Channel	Frequency	Conducted Power (dBm)	Max. Limit (dBm)	Result
52	5260 MHz	23.25	24.00	Complies
60	5300 MHz	23.12	24.00	Complies
64	5320 MHz	21.16	24.00	Complies
100	5500 MHz	19.17	24.00	Complies
116	5580 MHz	23.27	24.00	Complies
140	5700 MHz	17.24	24.00	Complies

**Configuration 802.11n MCS8 40MHz Ant. 4-1**

Channel	Frequency	Conducted Power (dBm)	Max. Limit (dBm)	Result
54	5270 MHz	19.04	24.00	Complies
62	5310 MHz	13.27	24.00	Complies
102	5510MHz	10.33	24.00	Complies
110	5550 MHz	17.52	24.00	Complies
134	5670 MHz	15.45	24.00	Complies

**Configuration 802.11n MCS8 40MHz Ant. 4-3**

Channel	Frequency	Conducted Power (dBm)	Max. Limit (dBm)	Result
54	5270 MHz	19.84	24.00	Complies
62	5310 MHz	13.87	24.00	Complies
102	5510MHz	10.44	24.00	Complies
110	5550 MHz	18.85	24.00	Complies
134	5670 MHz	16.05	24.00	Complies

**Configuration 802.11n MCS8 40MHz Ant. 4-1 + Ant. 4-3**

Channel	Frequency	Conducted Power (dBm)	Max. Limit (dBm)	Result
54	5270 MHz	22.47	24.00	Complies
62	5310 MHz	16.59	24.00	Complies
102	5510MHz	13.40	24.00	Complies
110	5550 MHz	21.25	24.00	Complies
134	5670 MHz	18.77	24.00	Complies

<b>Temperature</b>	21°C	<b>Humidity</b>	56%
<b>Test Engineer</b>	Johnson Chang	<b>Configurations</b>	802.11a / Antenna 4

**Configuration IEEE 802.11a Ant. 4-1**

Channel	Frequency	Conducted Power (dBm)	Max. Limit (dBm)	Result
52	5260 MHz	19.24	24.00	Complies
60	5300 MHz	19.52	24.00	Complies
64	5320 MHz	16.64	24.00	Complies
100	5500 MHz	15.58	24.00	Complies
116	5580 MHz	18.78	24.00	Complies
140	5700 MHz	16.17	24.00	Complies

**Configuration IEEE 802.11a Ant. 4-3**

Channel	Frequency	Conducted Power (dBm)	Max. Limit (dBm)	Result
52	5260 MHz	19.88	24.00	Complies
60	5300 MHz	20.07	24.00	Complies
64	5320 MHz	17.60	24.00	Complies
100	5500 MHz	16.29	24.00	Complies
116	5580 MHz	20.19	24.00	Complies
140	5700 MHz	16.70	24.00	Complies

**Configuration IEEE 802.11a Ant. 4-1 + Ant. 4-3**

Channel	Frequency	Conducted Power (dBm)	Max. Limit (dBm)	Result
52	5260 MHz	22.58	24.00	Complies
60	5300 MHz	22.81	24.00	Complies
64	5320 MHz	20.16	24.00	Complies
100	5500 MHz	18.96	24.00	Complies
116	5580 MHz	22.55	24.00	Complies
140	5700 MHz	19.45	24.00	Complies

<For Antenna 5>:

<b>Temperature</b>	21°C	<b>Humidity</b>	56%
<b>Test Engineer</b>	Johnson Chang	<b>Configurations</b>	802.11n / Antenna 5

**Configuration 802.11n MCS8 20MHz Ant. 5-1**

Channel	Frequency	Conducted Power (dBm)	Max. Limit (dBm)	Result
52	5260 MHz	19.78	24.00	Complies
60	5300 MHz	19.32	24.00	Complies
64	5320 MHz	16.49	24.00	Complies
100	5500 MHz	15.21	24.00	Complies
116	5580 MHz	19.46	24.00	Complies
140	5700 MHz	12.87	24.00	Complies

**Configuration 802.11n MCS8 20MHz Ant. 5-3**

Channel	Frequency	Conducted Power (dBm)	Max. Limit (dBm)	Result
52	5260 MHz	20.66	24.00	Complies
60	5300 MHz	20.77	24.00	Complies
64	5320 MHz	17.28	24.00	Complies
100	5500 MHz	15.98	24.00	Complies
116	5580 MHz	20.93	24.00	Complies
140	5700 MHz	13.38	24.00	Complies

**Configuration 802.11n MCS8 20MHz Ant. 5-1 + Ant. 5-3**

Channel	Frequency	Conducted Power (dBm)	Max. Limit (dBm)	Result
52	5260 MHz	23.25	24.00	Complies
60	5300 MHz	23.12	24.00	Complies
64	5320 MHz	19.91	24.00	Complies
100	5500 MHz	18.62	24.00	Complies
116	5580 MHz	23.27	24.00	Complies
140	5700 MHz	16.14	24.00	Complies

**Configuration 802.11n MCS8 40MHz Ant. 5-1**

Channel	Frequency	Conducted Power (dBm)	Max. Limit (dBm)	Result
54	5270 MHz	20.16	24.00	Complies
62	5310 MHz	13.60	24.00	Complies
102	5510MHz	11.17	24.00	Complies
110	5550 MHz	17.52	24.00	Complies
134	5670 MHz	14.84	24.00	Complies

**Configuration 802.11n MCS8 40MHz Ant. 5-3**

Channel	Frequency	Conducted Power (dBm)	Max. Limit (dBm)	Result
54	5270 MHz	20.96	24.00	Complies
62	5310 MHz	14.43	24.00	Complies
102	5510MHz	11.25	24.00	Complies
110	5550 MHz	18.85	24.00	Complies
134	5670 MHz	15.84	24.00	Complies

**Configuration 802.11n MCS8 40MHz Ant. 5-1 + Ant. 5-3**

Channel	Frequency	Conducted Power (dBm)	Max. Limit (dBm)	Result
54	5270 MHz	23.59	24.00	Complies
62	5310 MHz	17.05	24.00	Complies
102	5510MHz	14.22	24.00	Complies
110	5550 MHz	21.25	24.00	Complies
134	5670 MHz	18.38	24.00	Complies



<b>Temperature</b>	21°C	<b>Humidity</b>	56%
<b>Test Engineer</b>	Johnson Chang	<b>Configurations</b>	802.11a / Antenna 5

**Configuration IEEE 802.11a Ant. 5-1**

Channel	Frequency	Conducted Power (dBm)	Max. Limit (dBm)	Result
52	5260 MHz	19.24	24.00	Complies
60	5300 MHz	19.52	24.00	Complies
64	5320 MHz	16.64	24.00	Complies
100	5500 MHz	14.08	24.00	Complies
116	5580 MHz	18.78	24.00	Complies
140	5700 MHz	12.60	24.00	Complies

**Configuration IEEE 802.11a Ant. 5-3**

Channel	Frequency	Conducted Power (dBm)	Max. Limit (dBm)	Result
52	5260 MHz	19.88	24.00	Complies
60	5300 MHz	20.07	24.00	Complies
64	5320 MHz	17.60	24.00	Complies
100	5500 MHz	14.53	24.00	Complies
116	5580 MHz	20.19	24.00	Complies
140	5700 MHz	12.32	24.00	Complies

**Configuration IEEE 802.11a Ant. 5-1 + Ant. 5-3**

Channel	Frequency	Conducted Power (dBm)	Max. Limit (dBm)	Result
52	5260 MHz	22.58	24.00	Complies
60	5300 MHz	22.81	24.00	Complies
64	5320 MHz	20.16	24.00	Complies
100	5500 MHz	17.32	24.00	Complies
116	5580 MHz	22.55	24.00	Complies
140	5700 MHz	15.47	24.00	Complies

<For Antenna 6>:

<b>Temperature</b>	21°C	<b>Humidity</b>	56%
<b>Test Engineer</b>	Johnson Chang	<b>Configurations</b>	802.11n / Antenna 6

**Configuration 802.11n MCS8 20MHz Ant. 6-1**

Channel	Frequency	Conducted Power (dBm)	Max. Limit (dBm)	Result
52	5260 MHz	19.09	23.00	Complies
60	5300 MHz	18.57	23.00	Complies
64	5320 MHz	15.76	23.00	Complies
100	5500 MHz	15.21	23.00	Complies
116	5580 MHz	18.80	23.00	Complies
140	5700 MHz	13.76	23.00	Complies

**Configuration 802.11n MCS8 20MHz Ant. 6-3**

Channel	Frequency	Conducted Power (dBm)	Max. Limit (dBm)	Result
52	5260 MHz	19.23	23.00	Complies
60	5300 MHz	20.05	23.00	Complies
64	5320 MHz	17.00	23.00	Complies
100	5500 MHz	15.98	23.00	Complies
116	5580 MHz	20.21	23.00	Complies
140	5700 MHz	14.66	23.00	Complies

**Configuration 802.11n MCS8 20MHz Ant. 6-1 + Ant. 6-3**

Channel	Frequency	Conducted Power (dBm)	Max. Limit (dBm)	Result
52	5260 MHz	22.17	23.00	Complies
60	5300 MHz	22.38	23.00	Complies
64	5320 MHz	19.43	23.00	Complies
100	5500 MHz	18.62	23.00	Complies
116	5580 MHz	22.57	23.00	Complies
140	5700 MHz	17.24	23.00	Complies

**Configuration 802.11n MCS8 40MHz Ant. 6-1**

Channel	Frequency	Conducted Power (dBm)	Max. Limit (dBm)	Result
54	5270 MHz	19.04	23.00	Complies
62	5310 MHz	11.91	23.00	Complies
102	5510MHz	9.26	23.00	Complies
110	5550 MHz	16.72	23.00	Complies
134	5670 MHz	14.58	23.00	Complies

**Configuration 802.11n MCS8 40MHz Ant. 6-3**

Channel	Frequency	Conducted Power (dBm)	Max. Limit (dBm)	Result
54	5270 MHz	19.84	23.00	Complies
62	5310 MHz	12.83	23.00	Complies
102	5510MHz	9.80	23.00	Complies
110	5550 MHz	18.22	23.00	Complies
134	5670 MHz	15.45	23.00	Complies

**Configuration 802.11n MCS8 40MHz Ant. 6-1 + Ant. 6-3**

Channel	Frequency	Conducted Power (dBm)	Max. Limit (dBm)	Result
54	5270 MHz	22.47	23.00	Complies
62	5310 MHz	15.40	23.00	Complies
102	5510MHz	12.55	23.00	Complies
110	5550 MHz	20.54	23.00	Complies
134	5670 MHz	18.05	23.00	Complies

<b>Temperature</b>	21°C	<b>Humidity</b>	56%
<b>Test Engineer</b>	Johnson Chang	<b>Configurations</b>	802.11a / Antenna 6

**Configuration IEEE 802.11a Ant. 6-1**

Channel	Frequency	Conducted Power (dBm)	Max. Limit (dBm)	Result
52	5260 MHz	18.91	23.00	Complies
60	5300 MHz	18.81	23.00	Complies
64	5320 MHz	15.82	23.00	Complies
100	5500 MHz	14.08	23.00	Complies
116	5580 MHz	18.78	23.00	Complies
140	5700 MHz	12.32	23.00	Complies

**Configuration IEEE 802.11a Ant. 6-3**

Channel	Frequency	Conducted Power (dBm)	Max. Limit (dBm)	Result
52	5260 MHz	19.01	23.00	Complies
60	5300 MHz	18.97	23.00	Complies
64	5320 MHz	16.76	23.00	Complies
100	5500 MHz	14.53	23.00	Complies
116	5580 MHz	20.19	23.00	Complies
140	5700 MHz	12.60	23.00	Complies

**Configuration IEEE 802.11a Ant. 6-1 + Ant. 6-3**

Channel	Frequency	Conducted Power (dBm)	Max. Limit (dBm)	Result
52	5260 MHz	21.97	23.00	Complies
60	5300 MHz	21.90	23.00	Complies
64	5320 MHz	19.33	23.00	Complies
100	5500 MHz	17.32	23.00	Complies
116	5580 MHz	22.55	23.00	Complies
140	5700 MHz	15.47	23.00	Complies

<For Antenna 1>:

**Conducted Output Power Plot on Configuration 802.11n MCS8 20MHz Ant. 1-1 / 5260 MHz**

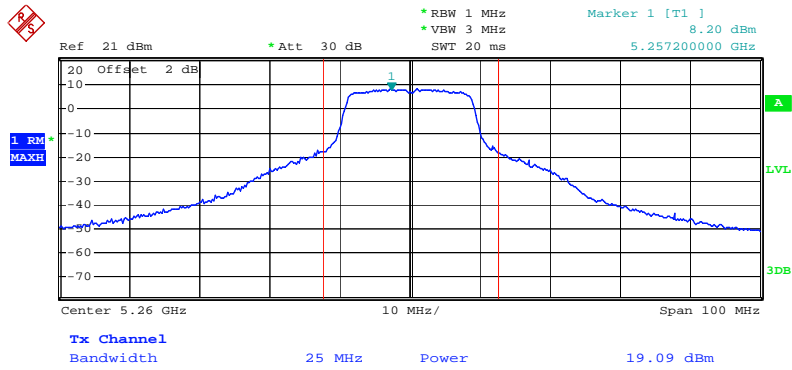

Date: 14.SEP.2009 22:20:07

**Conducted Output Power Plot on Configuration 802.11n MCS8 20MHz Ant. 1-1 / 5300 MHz**

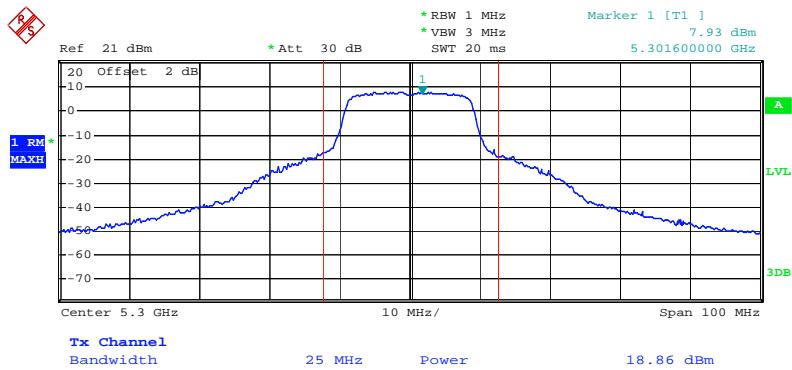

Date: 14.SEP.2009 22:19:21

### Conducted Output Power Plot on Configuration 802.11n MCS8 20MHz Ant. 1-1/ 5320 MHz

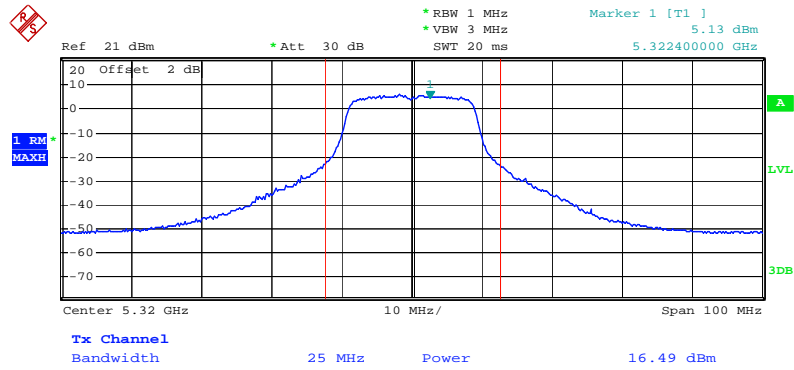

Date: 14.SEP.2009 22:14:47

### Conducted Output Power Plot on Configuration 802.11n MCS8 20MHz Ant. 1-1 / 5500 MHz

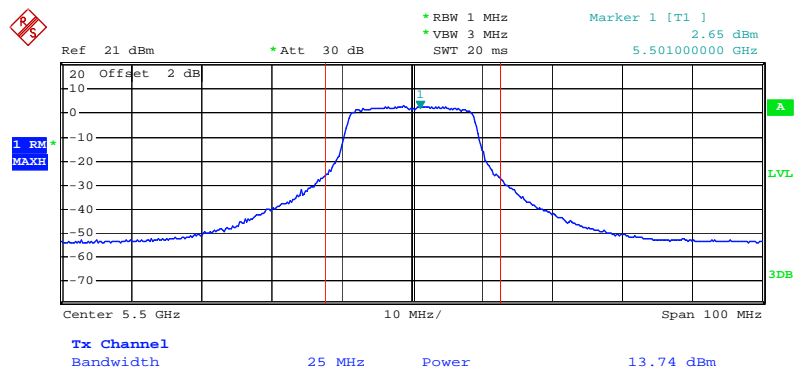

Date: 14.SEP.2009 22:10:38

Conducted Output Power Plot on Configuration 802.11n MCS8 20MHz Ant. 1-1 / 5580 MHz

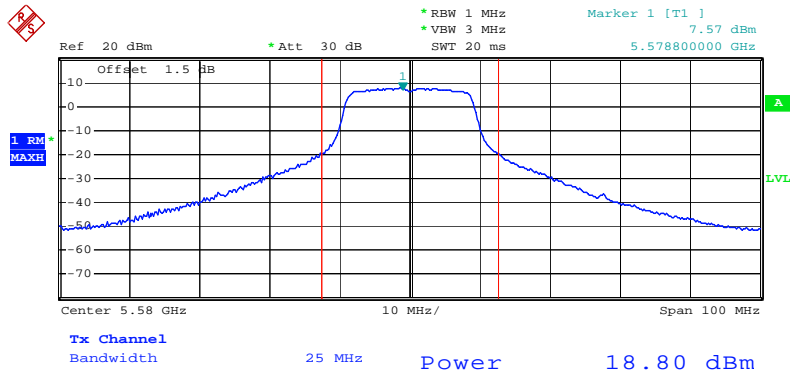

Date: 9.OCT.2009 17:06:14

Conducted Output Power Plot on Configuration 802.11n MCS8 20MHz Ant. 1-1 / 5700 MHz

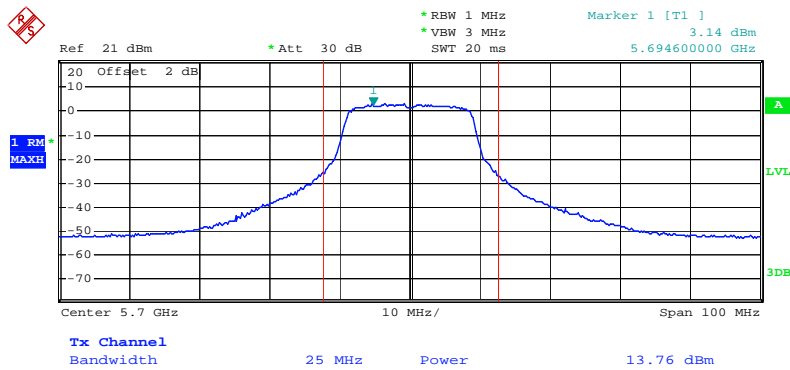

Date: 14.SEP.2009 22:06:36

### Conducted Output Power Plot on Configuration 802.11n MCS8 20MHz Ant. 1-3 / 5260 MHz

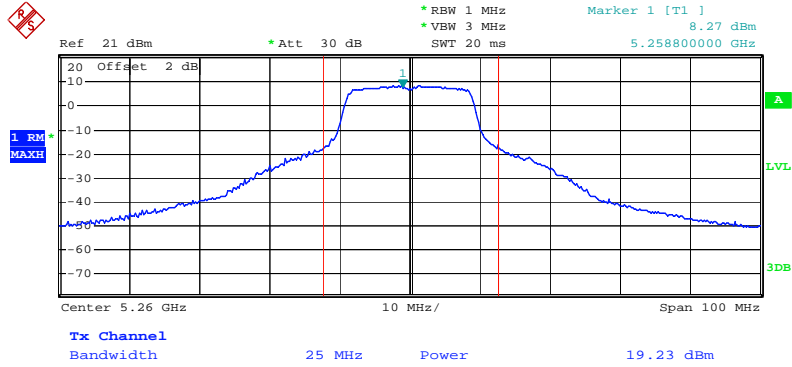

Date: 14.SEP.2009 21:42:56

### Conducted Output Power Plot on Configuration 802.11n MCS8 20MHz Ant. 1-3 / 5300 MHz

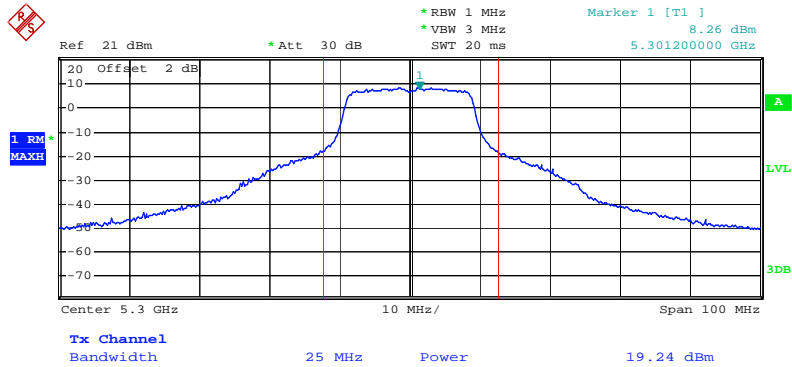

Date: 14.SEP.2009 21:45:58



### Conducted Output Power Plot on Configuration 802.11n MCS8 20MHz Ant. 1-3 / 5320 MHz

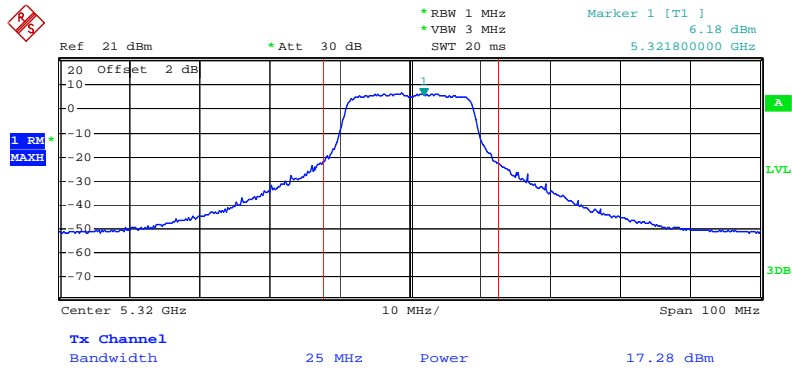

Date: 14.SEP.2009 21:49:07

### Conducted Output Power Plot on Configuration 802.11n MCS8 20MHz Ant. 1-3 / 5500 MHz

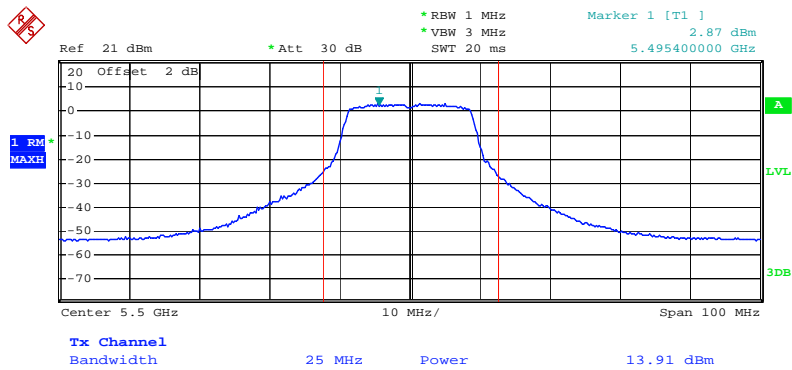

Date: 14.SEP.2009 21:56:33

### Conducted Output Power Plot on Configuration 802.11n MCS8 20MHz Ant. 1-3 / 5580 MHz

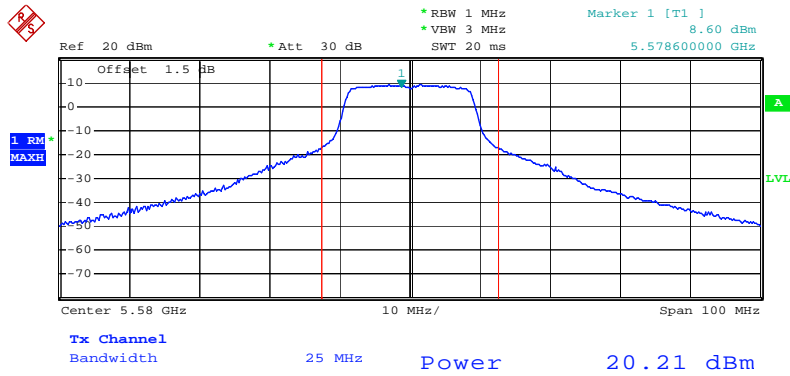

Date: 9.OCT.2009 17:04:58

### Conducted Output Power Plot on Configuration 802.11n MCS8 20MHz Ant. 1-3 / 5700 MHz

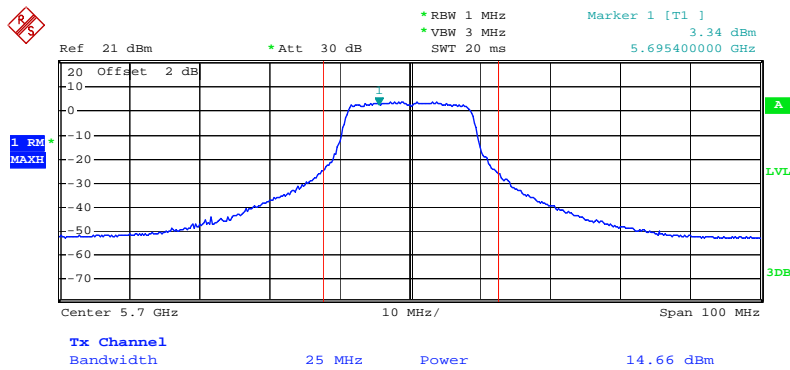

Date: 14.SEP.2009 22:01:03

**Conducted Output Power Plot on Configuration 802.11n MCS8 40MHz Ant. 1-1 / 5270 MHz**

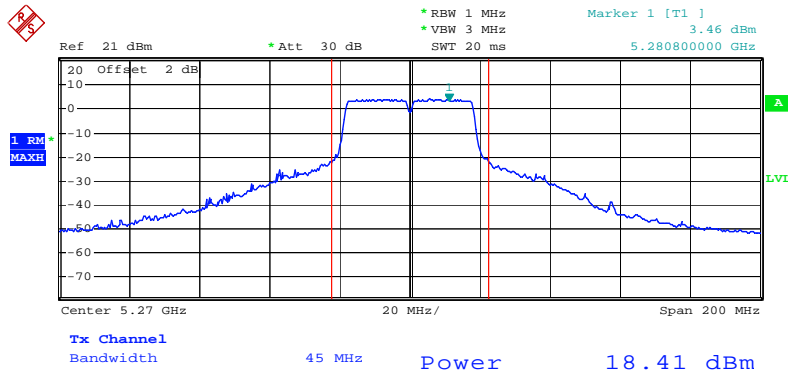

Date: 16.SEP.2009 22:09:49

**Conducted Output Power Plot on Configuration 802.11n MCS8 40MHz Ant. 1-1 / 5310 MHz**

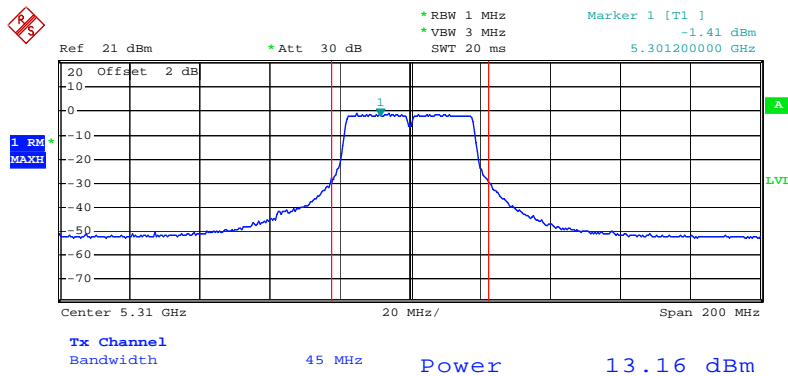

Date: 16.SEP.2009 22:11:23

**Conducted Output Power Plot on Configuration 802.11n MCS8 40MHz Ant. 1-1 / 5510MHz**

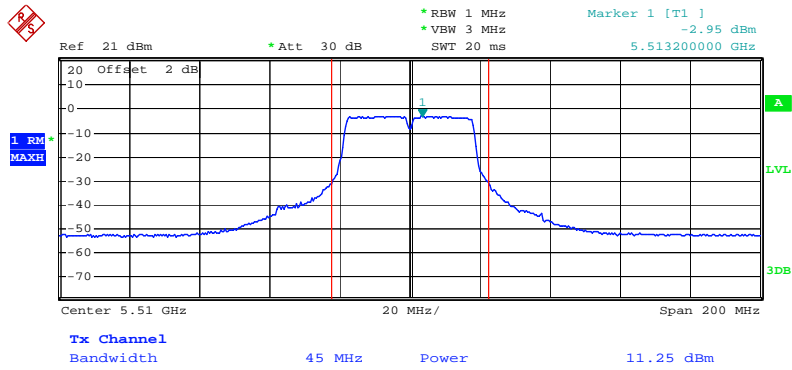

Date: 14.SEP.2009 22:49:14

**Conducted Output Power Plot on Configuration 802.11n MCS8 40MHz Ant. 1-1 / 5550 MHz**

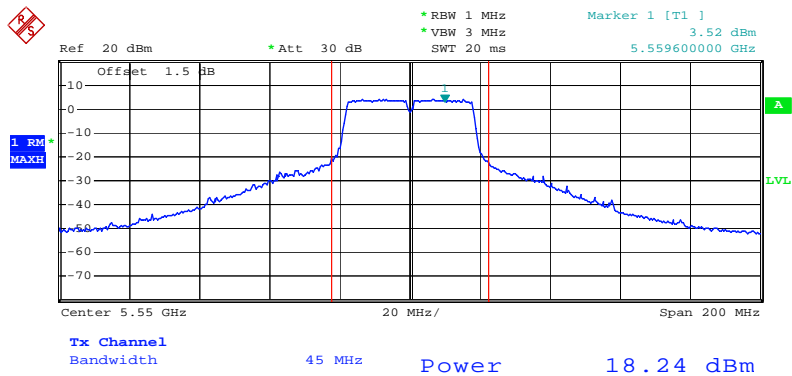

Date: 9.OCT.2009 17:01:15

**Conducted Output Power Plot on Configuration 802.11n MCS8 40MHz Ant. 1-1 / 5670 MHz**

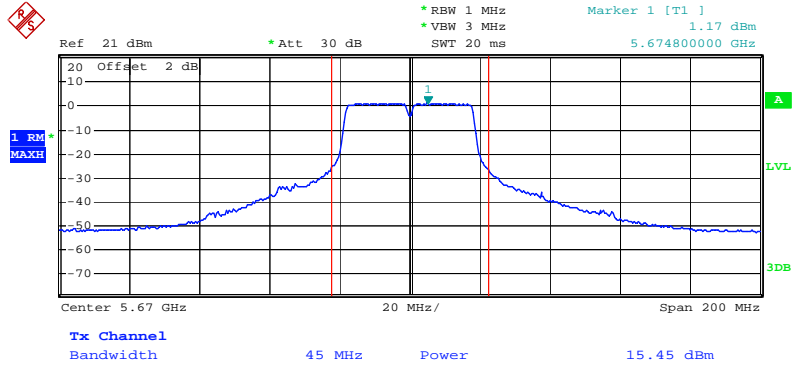

Date: 14.SEP.2009 22:55:53

**Conducted Output Power Plot on Configuration 802.11n MCS8 40MHz Ant. 1-3 / 5270 MHz**

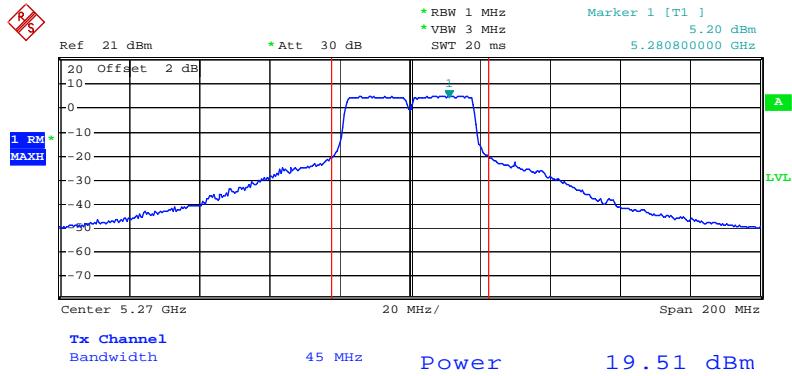

Date: 16.SEP.2009 22:09:38

**Conducted Output Power Plot on Configuration 802.11n MCS8 40MHz Ant. 1-3 / 5310 MHz**

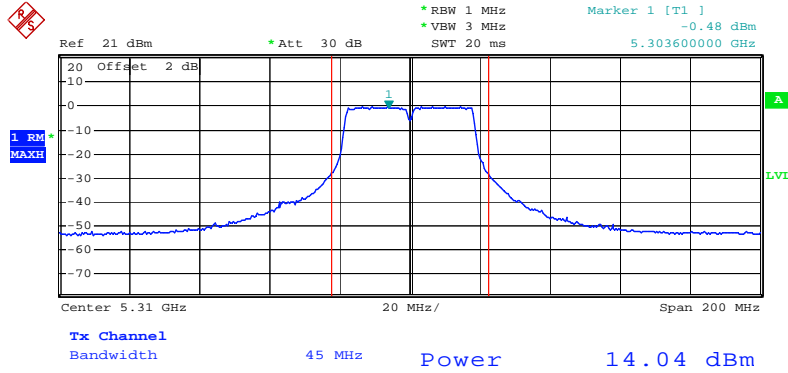

Date: 16.SEP.2009 22:11:41

**Conducted Output Power Plot on Configuration 802.11n MCS8 40MHz Ant. 1-3 / 5510MHz**

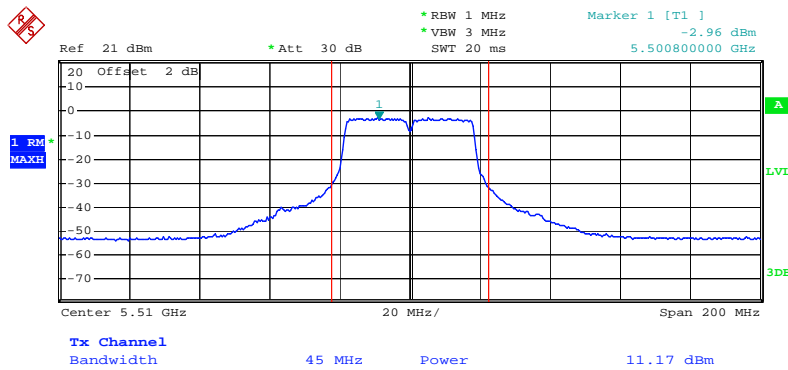

Date: 14.SEP.2009 23:09:19

**Conducted Output Power Plot on Configuration 802.11n MCS8 40MHz Ant. 1-3 / 5550 MHz**

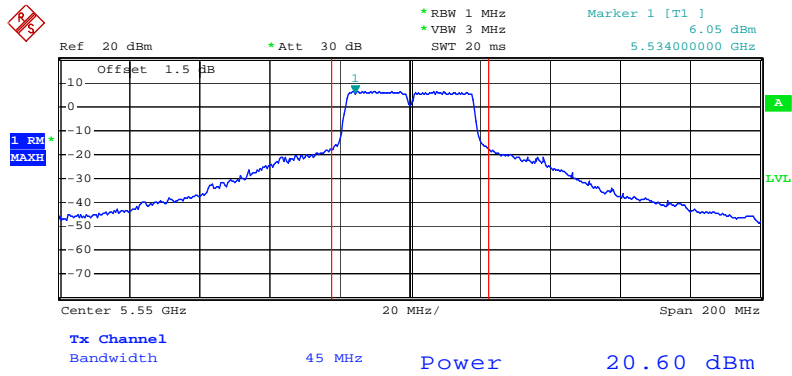

Date: 9.OCT.2009 17:02:49

**Conducted Output Power Plot on Configuration 802.11n MCS8 40MHz Ant. 1-3 / 5670 MHz**

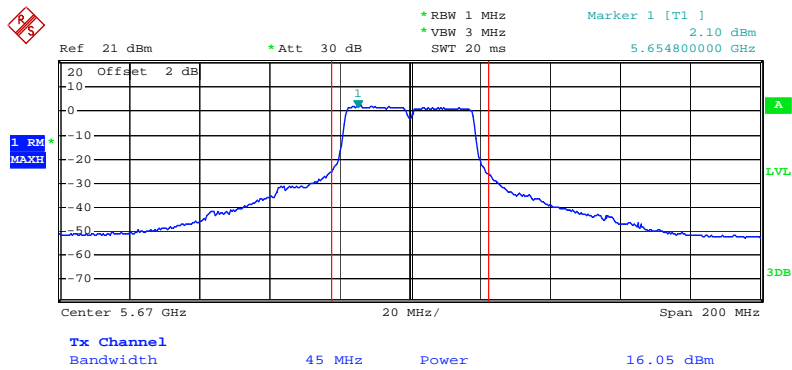

Date: 14.SEP.2009 23:06:52

**Conducted Output Power Plot on Configuration IEEE 802.11a Ant. 1-1 / 5260 MHz**

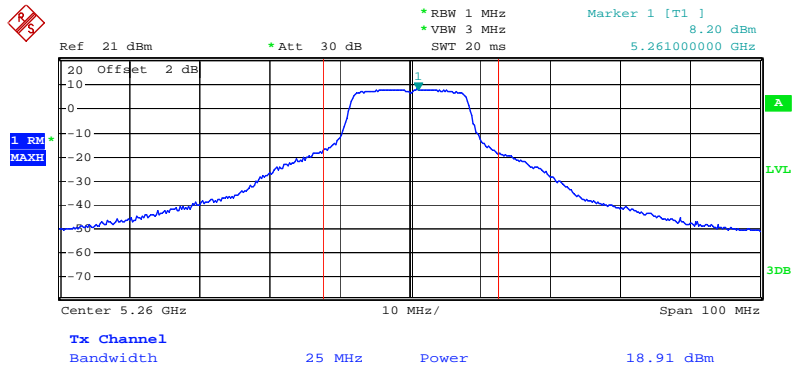

Date: 14.SEP.2009 20:41:55

**Conducted Output Power Plot on Configuration IEEE 802.11a Ant. 1-1 / 5300 MHz**

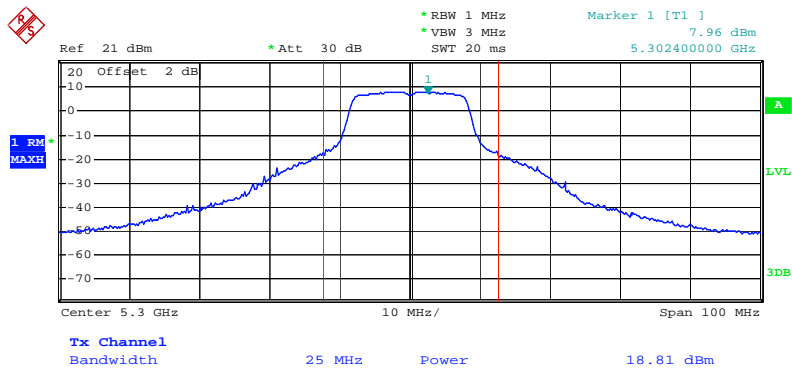

Date: 14.SEP.2009 20:46:09



### Conducted Output Power Plot on Configuration IEEE 802.11a Ant. 1-1 / 5320 MHz

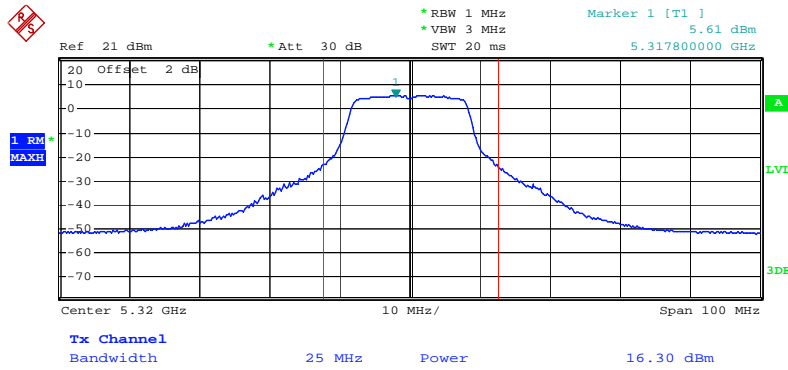

Date: 14.SEP.2009 20:47:23

### Conducted Output Power Plot on Configuration IEEE 802.11a Ant. 1-1 / 5500 MHz

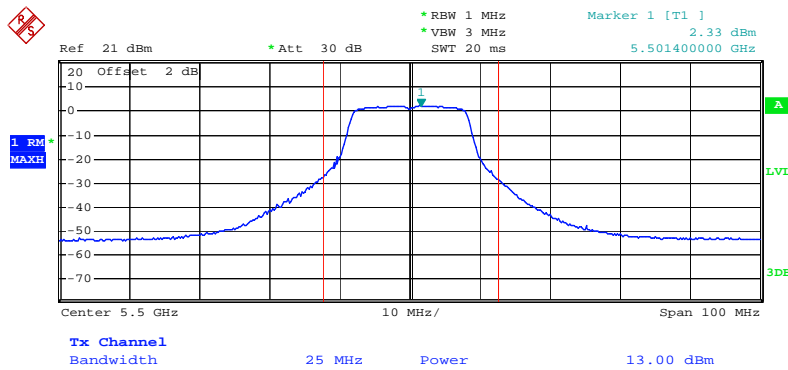

Date: 14.SEP.2009 20:51:04

**Conducted Output Power Plot on Configuration IEEE 802.11a Ant. 1-1 / 5580 MHz**

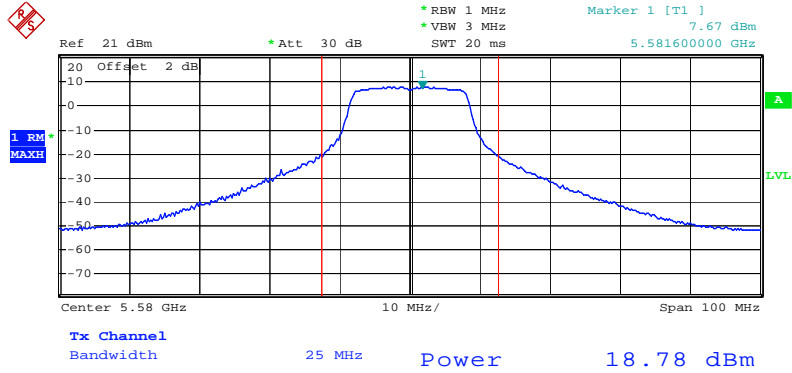

Date: 16.SEP.2009 21:27:49

**Conducted Output Power Plot on Configuration IEEE 802.11a Ant. 1-1 / 5700 MHz**

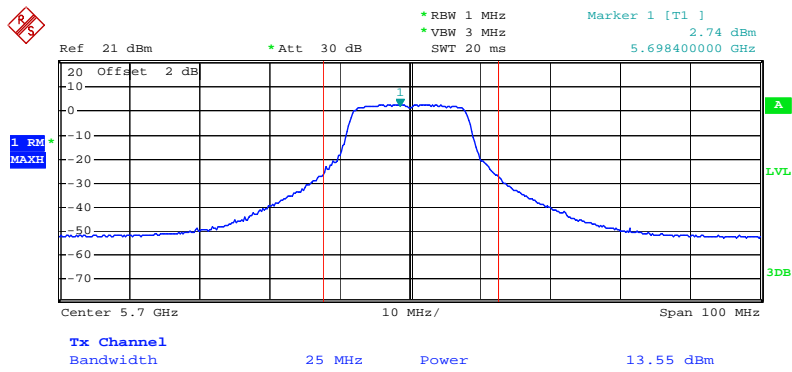

Date: 14.SEP.2009 20:55:38

### Conducted Output Power Plot on Configuration IEEE 802.11a Ant. 1-3 / 5260 MHz

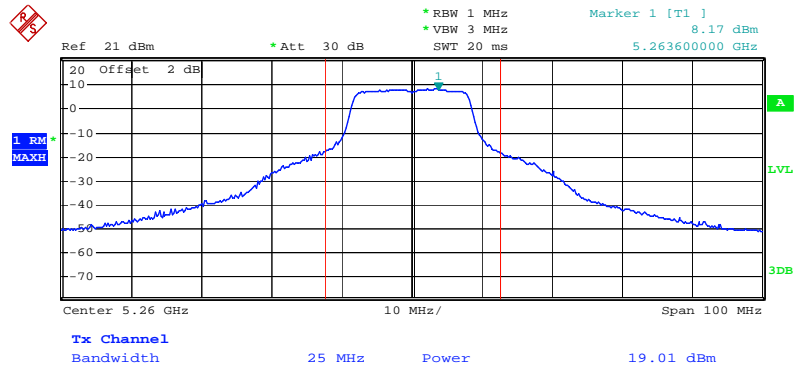

Date: 14.SEP.2009 21:16:59

### Conducted Output Power Plot on Configuration IEEE 802.11a Ant. 1-3 / 5300 MHz

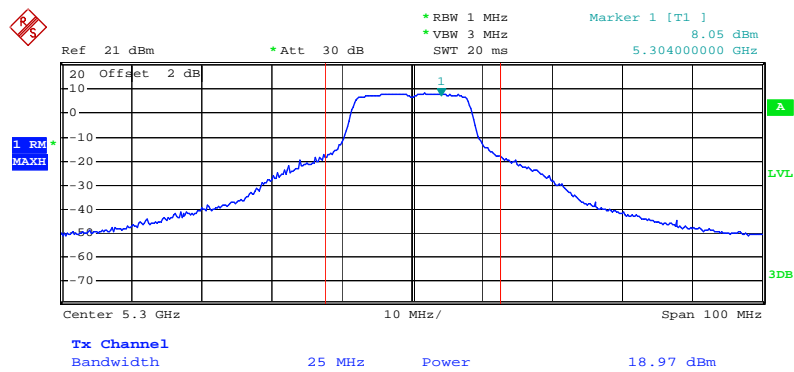

Date: 14.SEP.2009 21:16:13

### Conducted Output Power Plot on Configuration IEEE 802.11a Ant. 1-3 / 5320 MHz

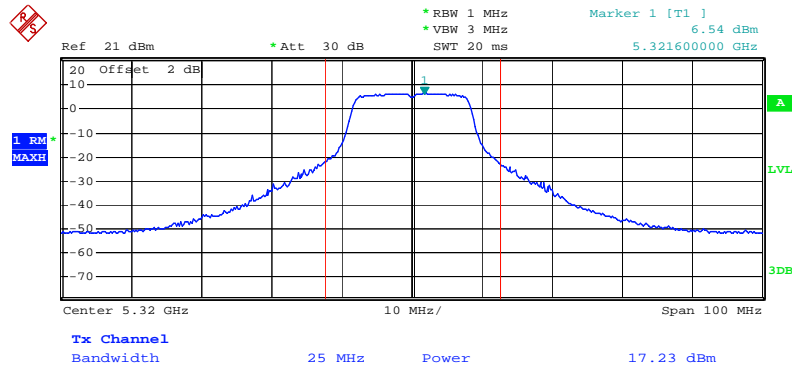

Date: 14.SEP.2009 21:11:27

### Conducted Output Power Plot on Configuration IEEE 802.11a Ant. 1-3 / 5500 MHz

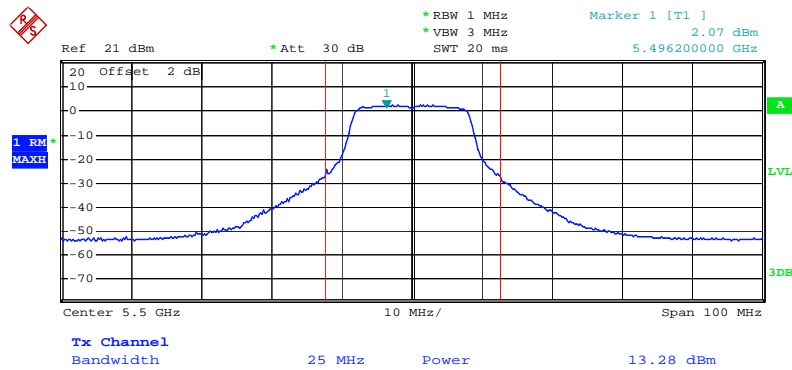

Date: 14.SEP.2009 21:08:26

### Conducted Output Power Plot on Configuration IEEE 802.11a Ant. 1-3 / 5580 MHz

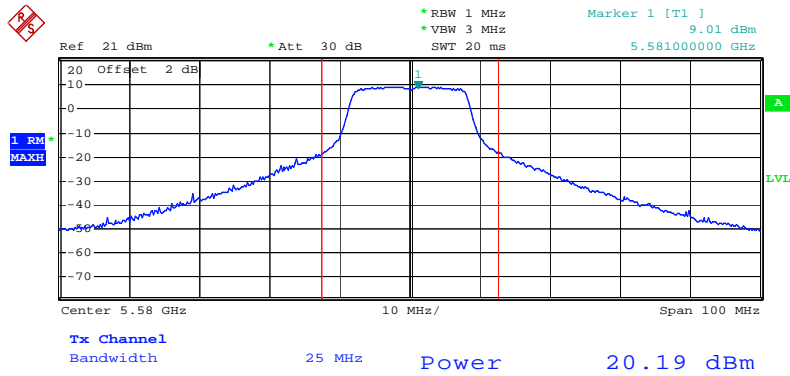

Date: 16.SEP.2009 21:27:24

### Conducted Output Power Plot on Configuration IEEE 802.11a Ant. 1-3 / 5700 MHz

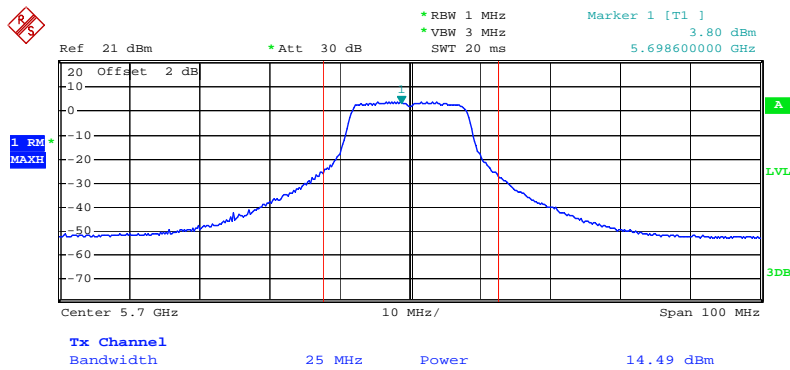

Date: 14.SEP.2009 21:02:43

<For Antenna 2>:

**Conducted Output Power Plot on Configuration 802.11n MCS8 20MHz Ant. 2-1 / 5260 MHz**

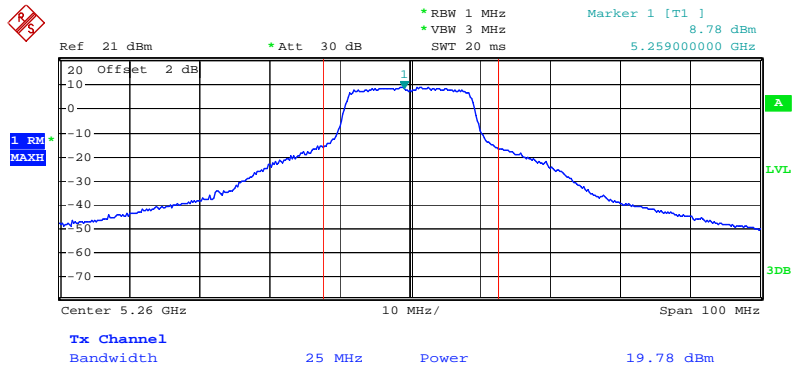

Date: 14.SEP.2009 22:21:00

**Conducted Output Power Plot on Configuration 802.11n MCS8 20MHz Ant. 2-1 / 5300 MHz**

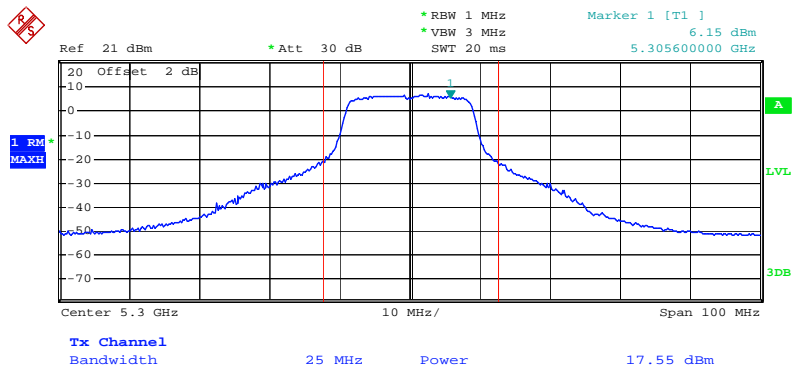

Date: 14.SEP.2009 22:18:34

### Conducted Output Power Plot on Configuration 802.11n MCS8 20MHz Ant. 2-1 / 5320 MHz

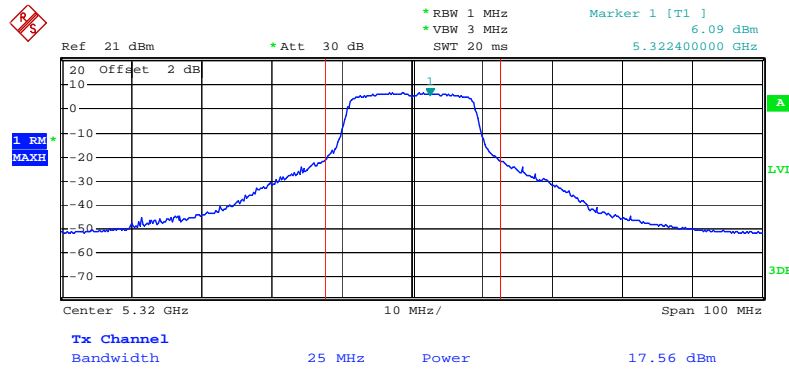

Date: 14.SEP.2009 22:15:32

### Conducted Output Power Plot on Configuration 802.11n MCS8 20MHz Ant. 2-1 / 5500 MHz

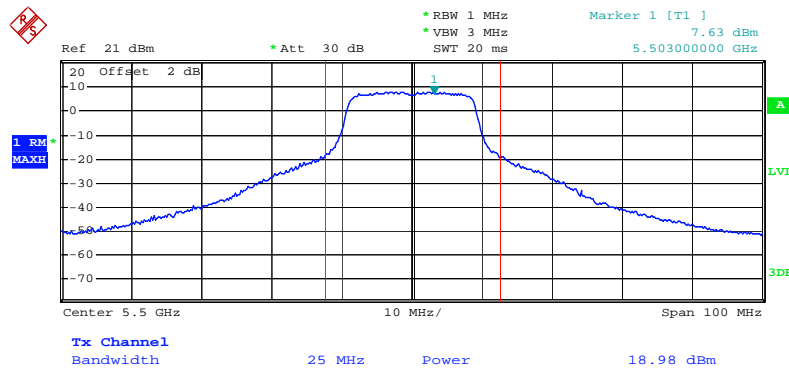

Date: 14.SEP.2009 22:11:17

**Conducted Output Power Plot on Configuration 802.11n MCS8 20MHz Ant. 2-1 / 5580 MHz**

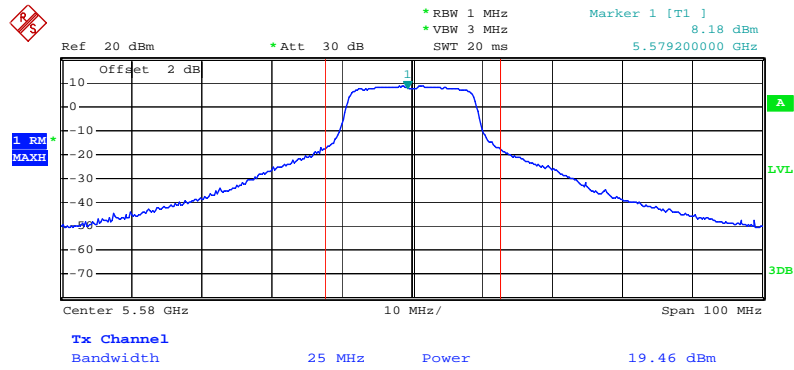

Date: 15.SEP.2009 16:30:36

**Conducted Output Power Plot on Configuration 802.11n MCS8 20MHz Ant. 2-1 / 5700 MHz**

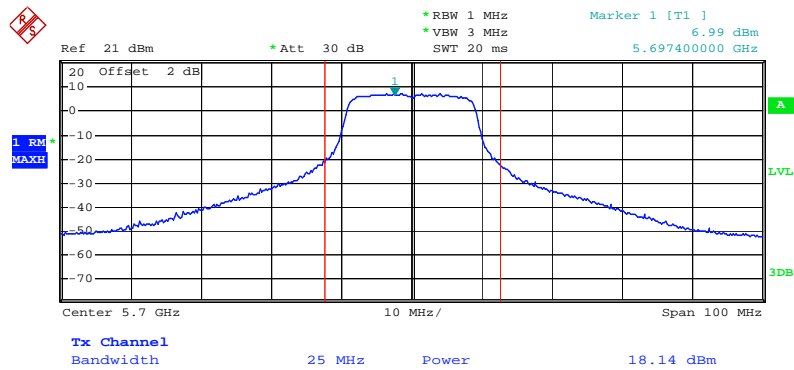

Date: 14.SEP.2009 22:02:05



### Conducted Output Power Plot on Configuration 802.11n MCS8 20MHz Ant. 2-3 / 5260 MHz

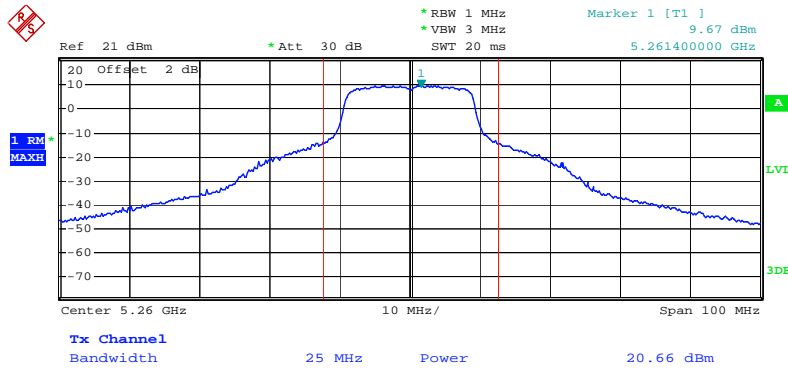

Date: 14.SEP.2009 21:43:32

### Conducted Output Power Plot on Configuration 802.11n MCS8 20MHz Ant. 2-3 / 5300 MHz

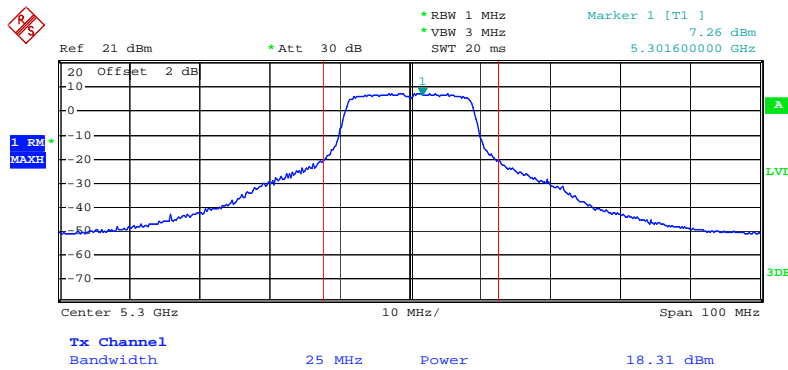

Date: 14.SEP.2009 21:46:31

### Conducted Output Power Plot on Configuration 802.11n MCS8 20MHz Ant. 2-3 / 5320 MHz

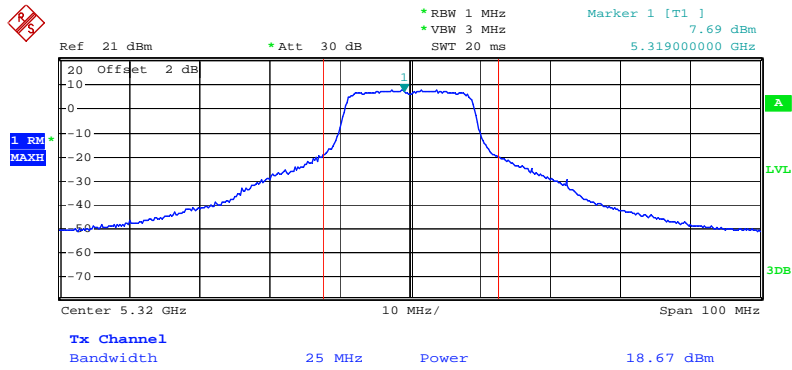

Date: 14.SEP.2009 21:49:48

### Conducted Output Power Plot on Configuration 802.11n MCS8 20MHz Ant. 2-3 / 5500 MHz

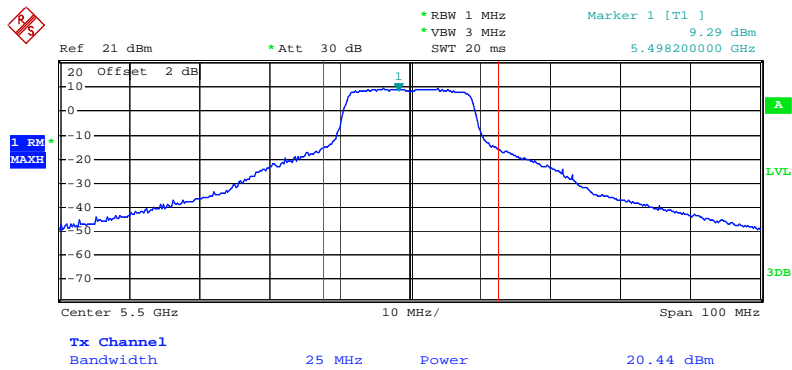

Date: 14.SEP.2009 21:57:08

**Conducted Output Power Plot on Configuration 802.11n MCS8 20MHz Ant. 2-3 / 5580 MHz**

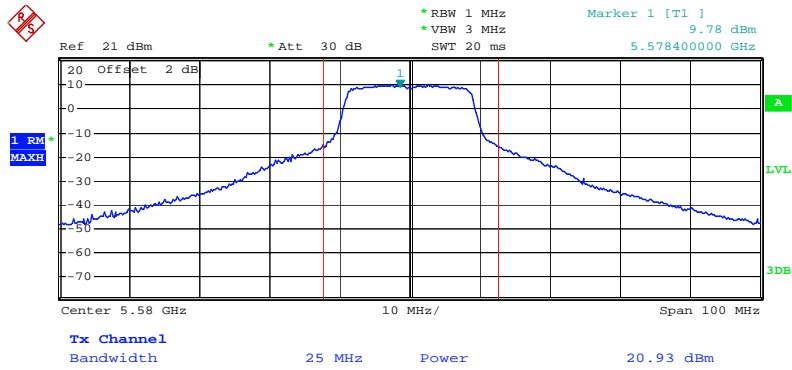

Date: 14.SEP.2009 21:59:55

**Conducted Output Power Plot on Configuration 802.11n MCS8 20MHz Ant. 2-3 / 5700 MHz**

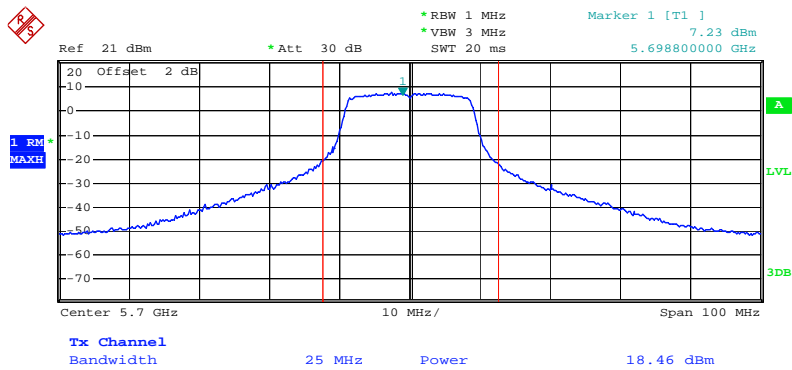

Date: 14.SEP.2009 22:08:33

**Conducted Output Power Plot on Configuration 802.11n MCS8 40MHz Ant. 2-1 / 5270 MHz**

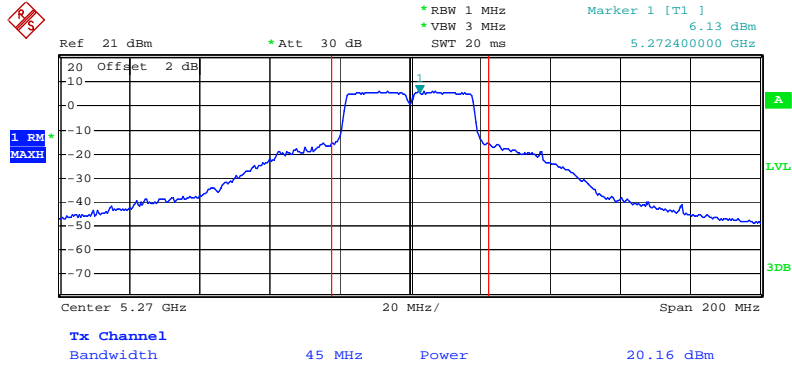

Date: 14.SEP.2009 22:42:26

**Conducted Output Power Plot on Configuration 802.11n MCS8 40MHz Ant. 2-1 / 5310 MHz**

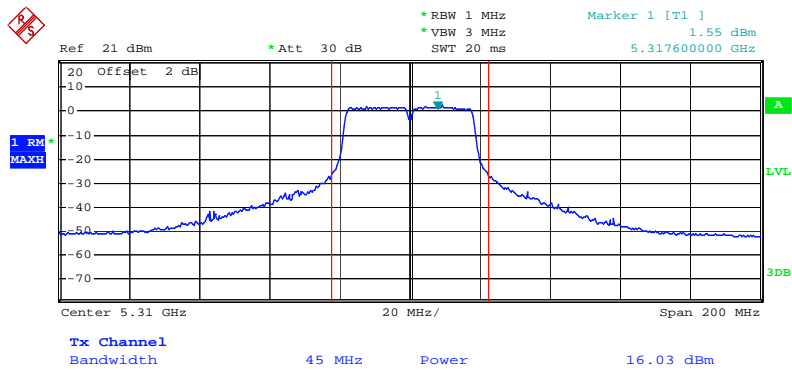

Date: 14.SEP.2009 22:47:11

### Conducted Output Power Plot on Configuration 802.11n MCS8 40MHz Ant. 2-1 / 5510MHz

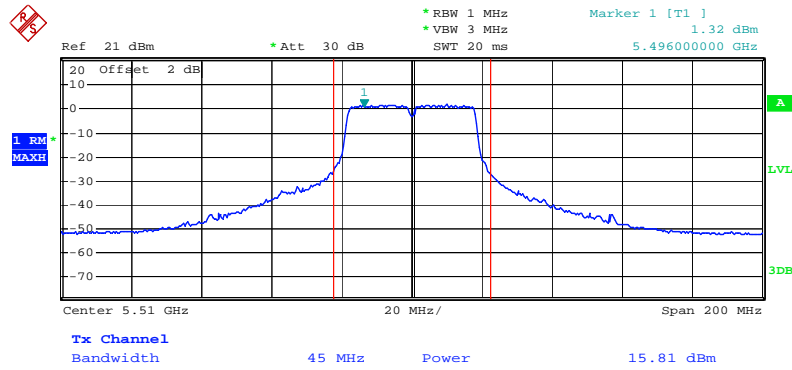

Date: 14.SEP.2009 22:49:54

### Conducted Output Power Plot on Configuration 802.11n MCS8 40MHz Ant. 2-1 / 5550 MHz

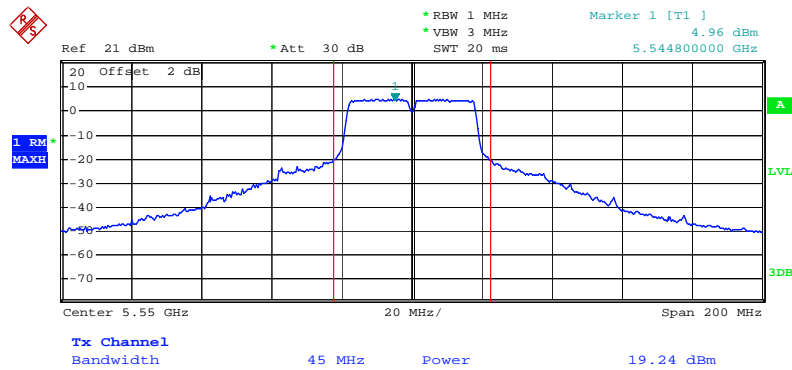

Date: 14.SEP.2009 23:00:44

**Conducted Output Power Plot on Configuration 802.11n MCS8 40MHz Ant. 2-1 / 5670 MHz**

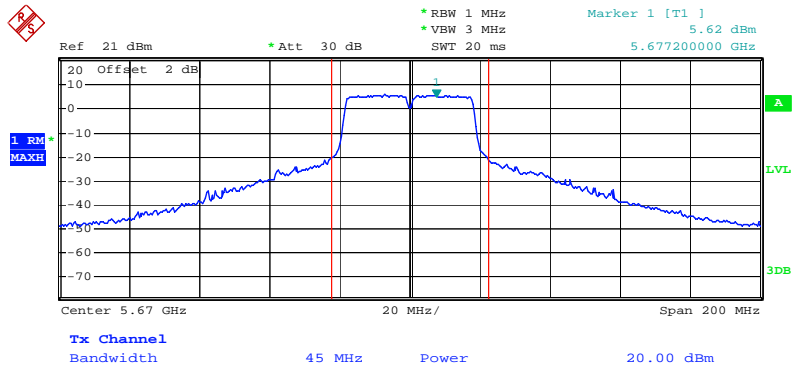

Date: 14.SEP.2009 22:56:41

**Conducted Output Power Plot on Configuration 802.11n MCS8 40MHz Ant. 2-3 / 5270 MHz**

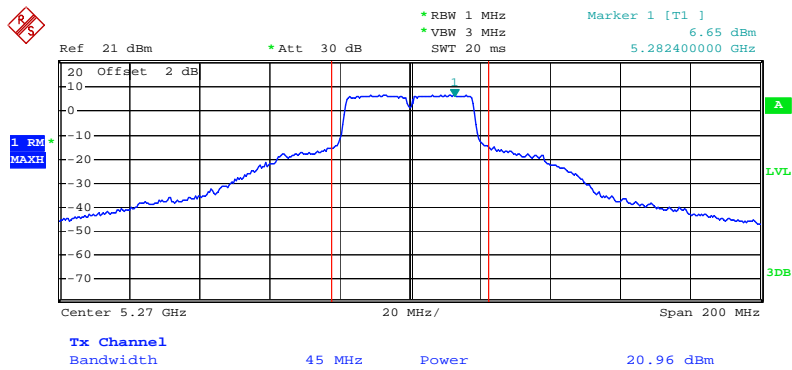

Date: 14.SEP.2009 23:19:24

### Conducted Output Power Plot on Configuration 802.11n MCS8 40MHz Ant. 2-3 / 5310 MHz

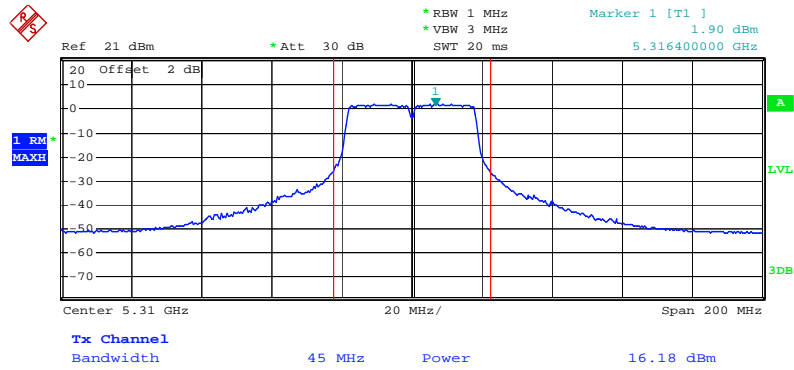

Date: 14.SEP.2009 23:14:57

### Conducted Output Power Plot on Configuration 802.11n MCS8 40MHz Ant. 2-3 / 5510MHz

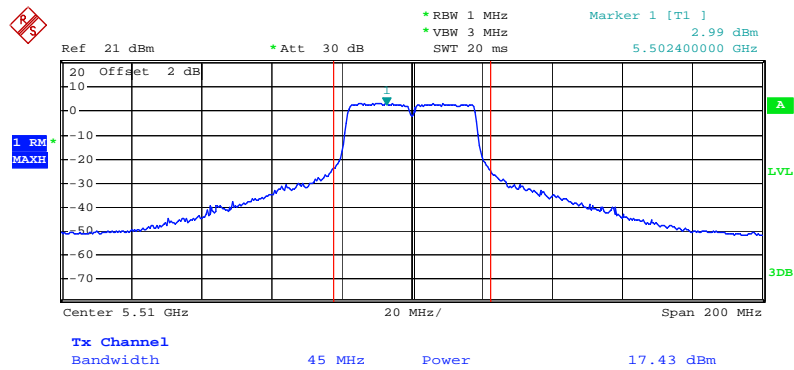

Date: 14.SEP.2009 23:10:11

### Conducted Output Power Plot on Configuration 802.11n MCS8 40MHz Ant. 2-3 / 5550 MHz

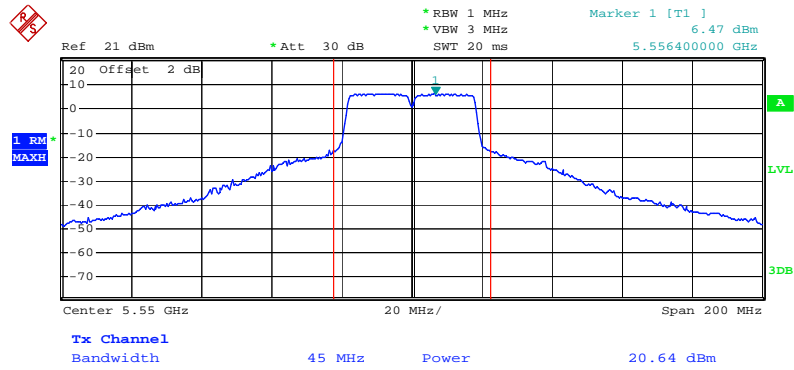

Date: 14.SEP.2009 23:02:28

### Conducted Output Power Plot on Configuration 802.11n MCS8 40MHz Ant. 2-3 / 5670 MHz

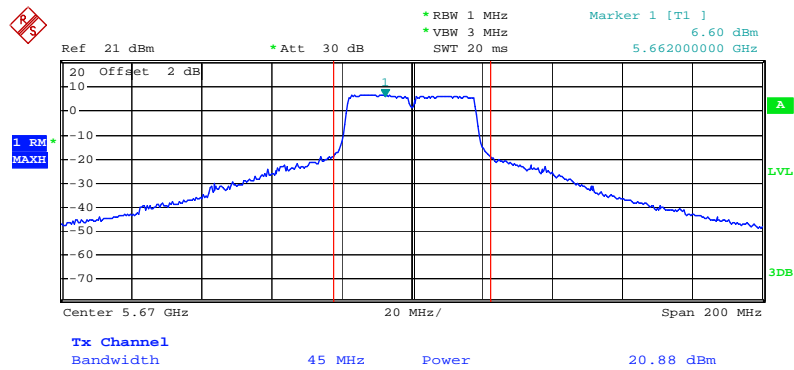

Date: 14.SEP.2009 23:08:32



### Conducted Output Power Plot on Configuration IEEE 802.11a Ant. 2-1 / 5260 MHz

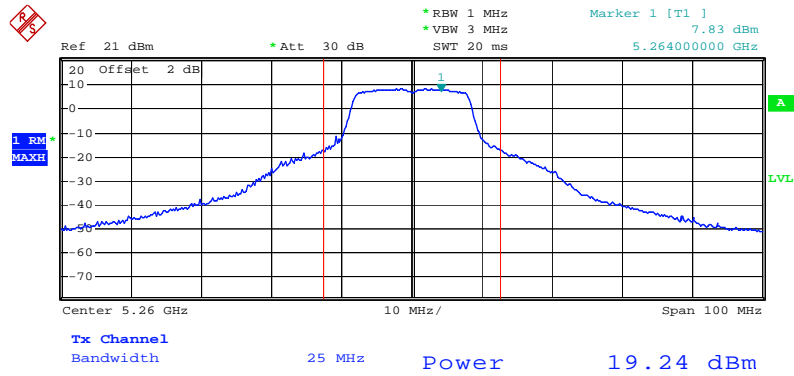

Date: 16.SEP.2009 21:22:16

### Conducted Output Power Plot on Configuration IEEE 802.11a Ant. 2-1 / 5300 MHz

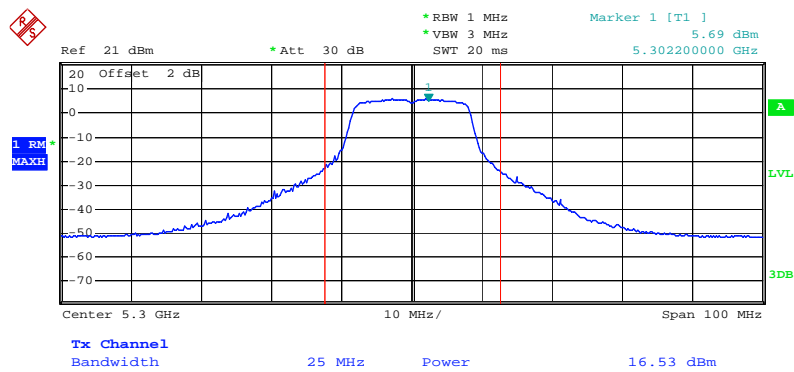

Date: 14.SEP.2009 20:46:39

## Conducted Output Power Plot on Configuration IEEE 802.11a Ant. 2-1 / 5320 MHz

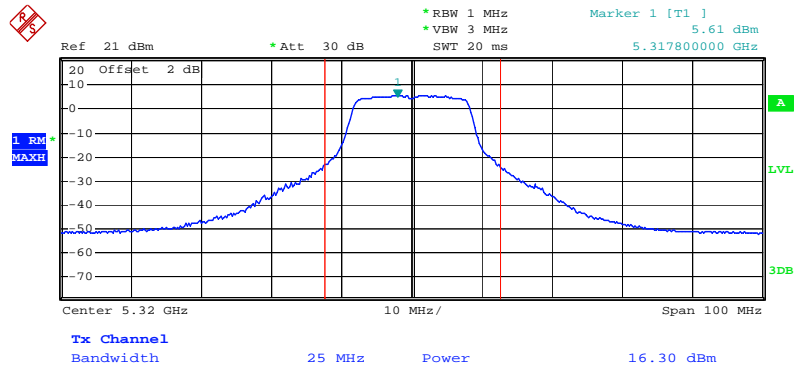

Date: 14.SEP.2009 20:47:23

## Conducted Output Power Plot on Configuration IEEE 802.11a Ant. 2-1 / 5500 MHz

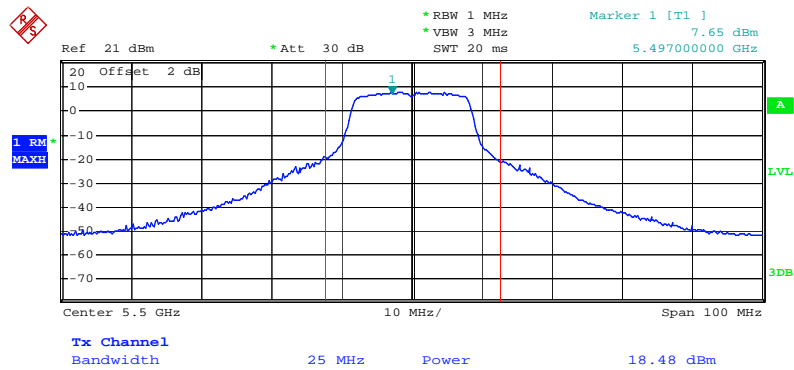

Date: 14.SEP.2009 20:51:35

**Conducted Output Power Plot on Configuration IEEE 802.11a Ant. 2-1 / 5580 MHz**

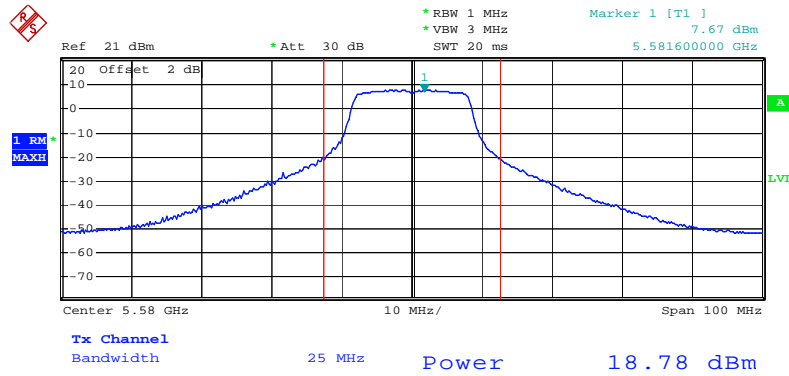

Date: 16.SEP.2009 21:27:49

**Conducted Output Power Plot on Configuration IEEE 802.11a Ant. 2-1 / 5700 MHz**

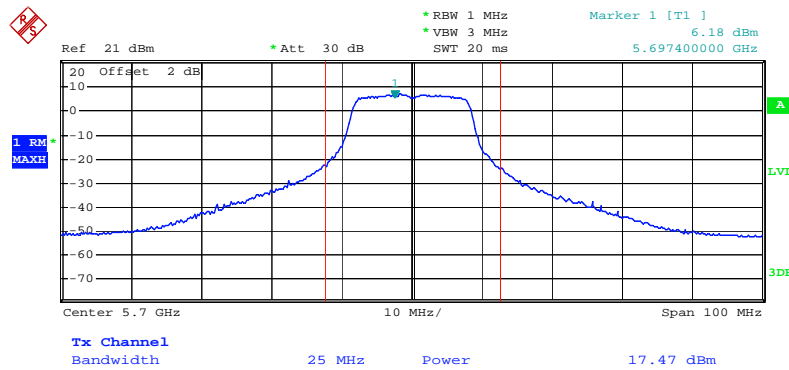

Date: 14.SEP.2009 21:02:05

### Conducted Output Power Plot on Configuration IEEE 802.11a Ant. 2-3 / 5260 MHz

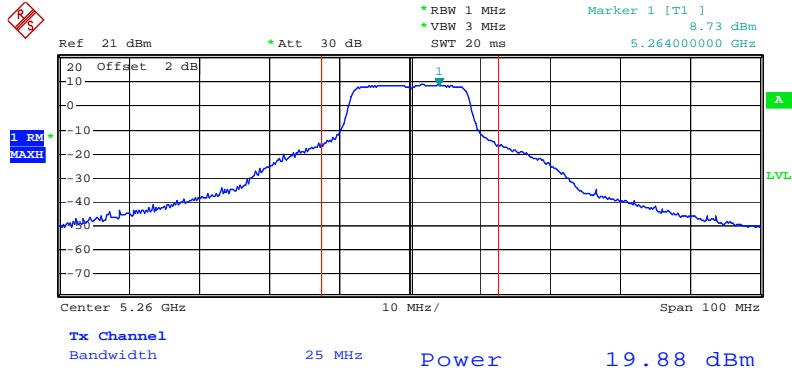

Date: 16.SEP.2009 21:21:57

### Conducted Output Power Plot on Configuration IEEE 802.11a Ant. 2-3 / 5300 MHz

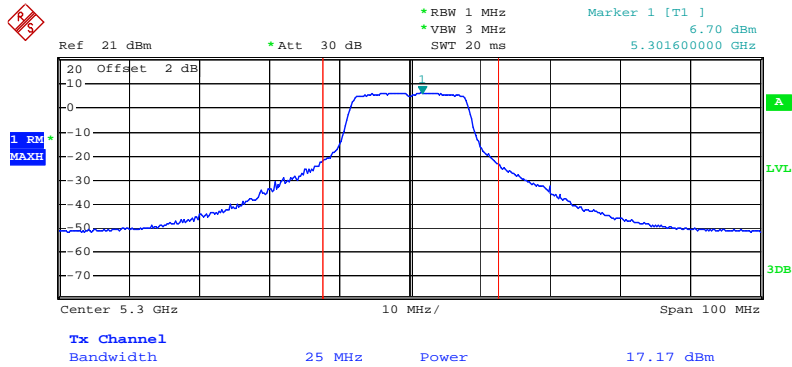

Date: 14.SEP.2009 21:15:30

### Conducted Output Power Plot on Configuration IEEE 802.11a Ant. 2-3 / 5320 MHz

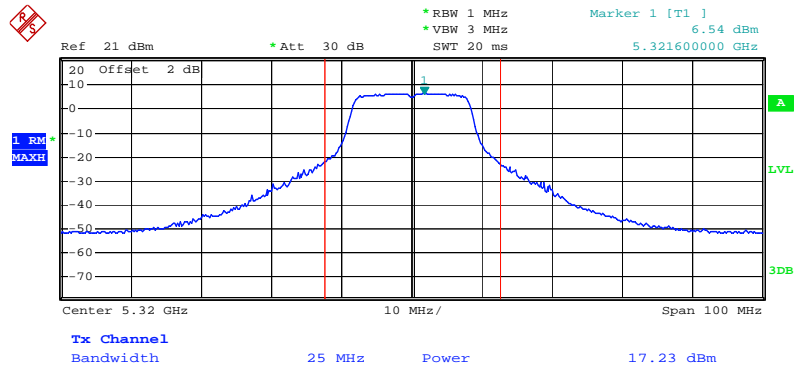

Date: 14.SEP.2009 21:11:27

### Conducted Output Power Plot on Configuration IEEE 802.11a Ant. 2-3 / 5500 MHz

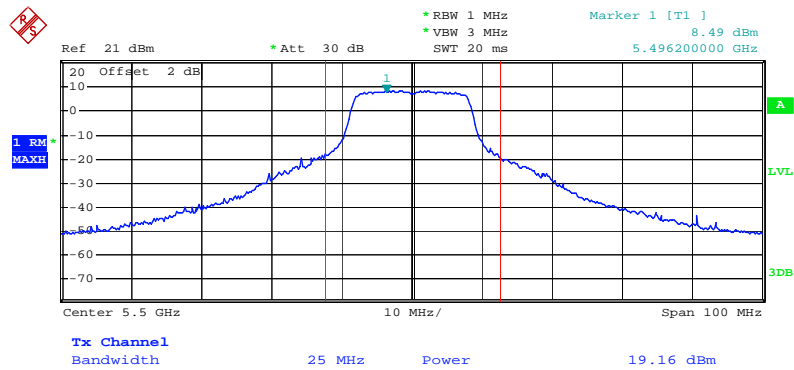

Date: 14.SEP.2009 21:07:53

### Conducted Output Power Plot on Configuration IEEE 802.11a Ant. 2-3 / 5580 MHz

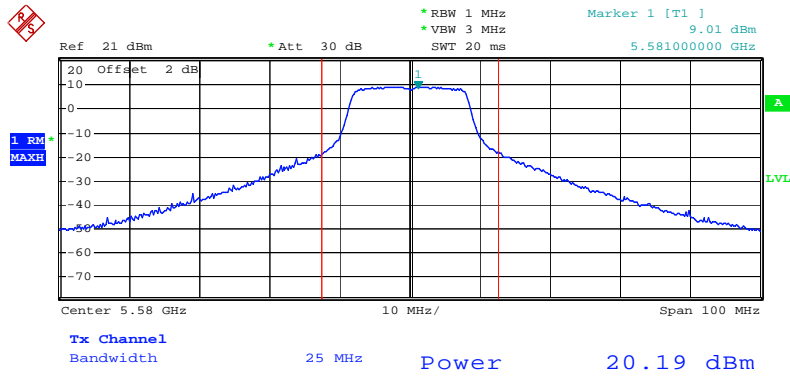

Date: 16.SEP.2009 21:27:24

### Conducted Output Power Plot on Configuration IEEE 802.11a Ant. 2-3 / 5700 MHz

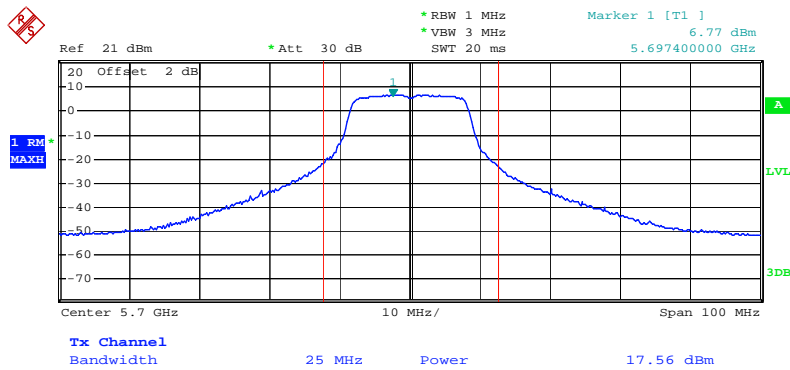

Date: 14.SEP.2009 20:56:14

<For Antenna 3>:

**Conducted Output Power Plot on Configuration 802.11n MCS8 20MHz Ant. 3-1 / 5260 MHz**

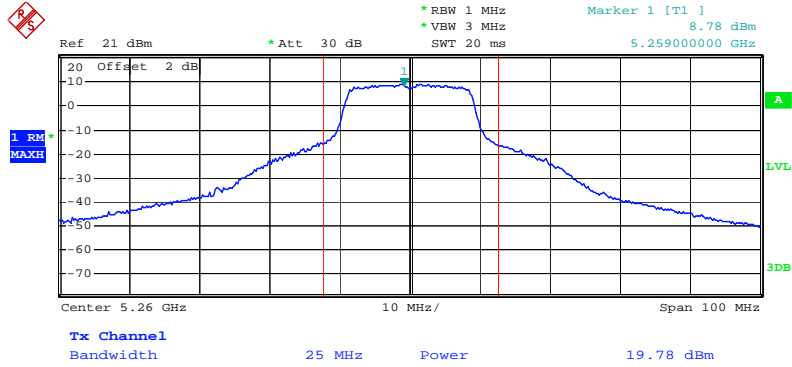

Date: 14.SEP.2009 22:21:00

**Conducted Output Power Plot on Configuration 802.11n MCS8 20MHz Ant. 3-1 / 5300 MHz**

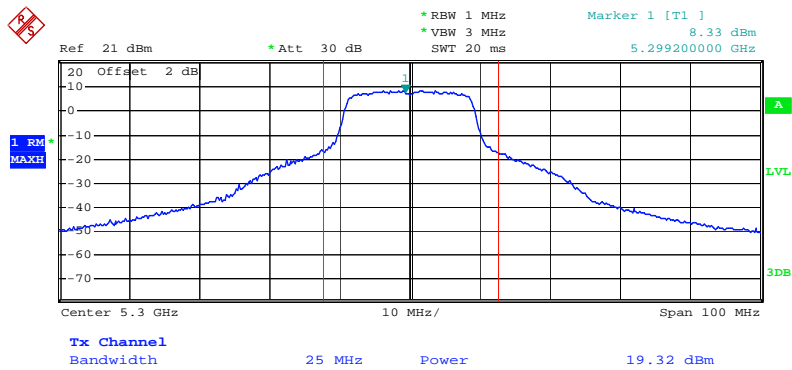

Date: 14.SEP.2009 22:17:45

### Conducted Output Power Plot on Configuration 802.11n MCS8 20MHz Ant. 3-1 / 5320 MHz

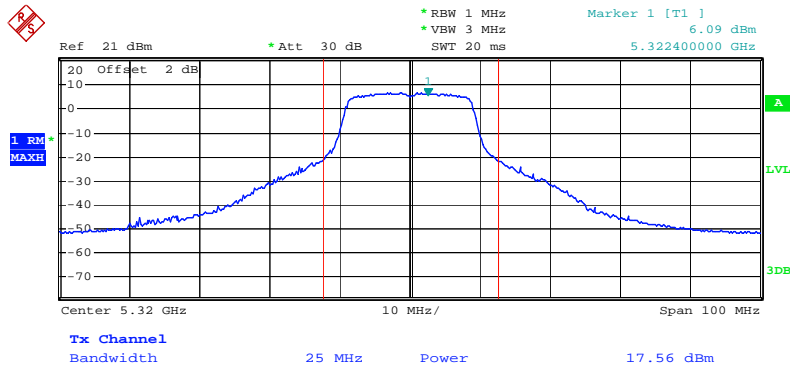

Date: 14.SEP.2009 22:15:32

### Conducted Output Power Plot on Configuration 802.11n MCS8 20MHz Ant. 3-1 / 5500 MHz

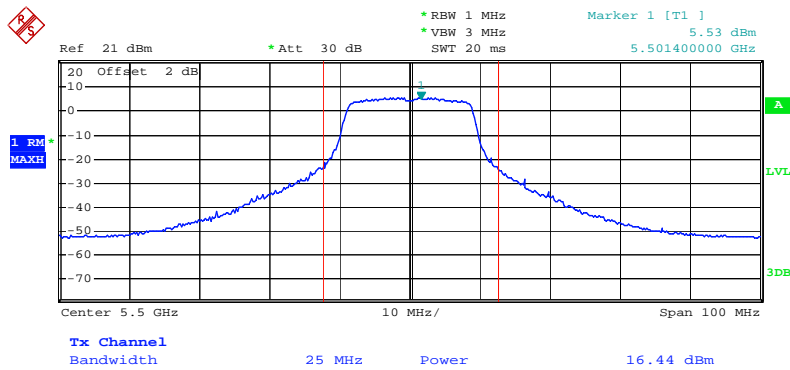

Date: 14.SEP.2009 22:11:52



**Conducted Output Power Plot on Configuration 802.11n MCS8 20MHz Ant. 3-1 / 5580 MHz**

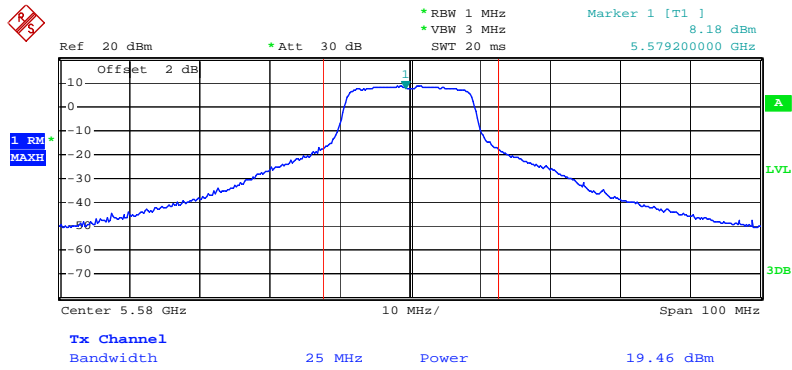

Date: 15.SEP.2009 16:30:36

**Conducted Output Power Plot on Configuration 802.11n MCS8 20MHz Ant. 3-1 / 5700 MHz**

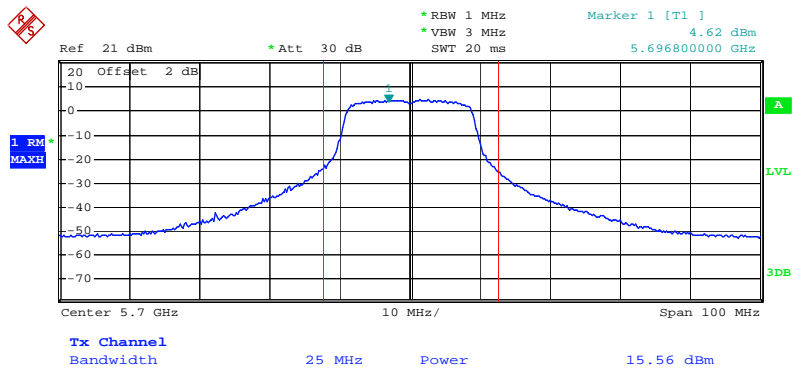

Date: 14.SEP.2009 22:07:53

**Conducted Output Power Plot on Configuration 802.11n MCS8 20MHz Ant. 3-3 / 5260 MHz**

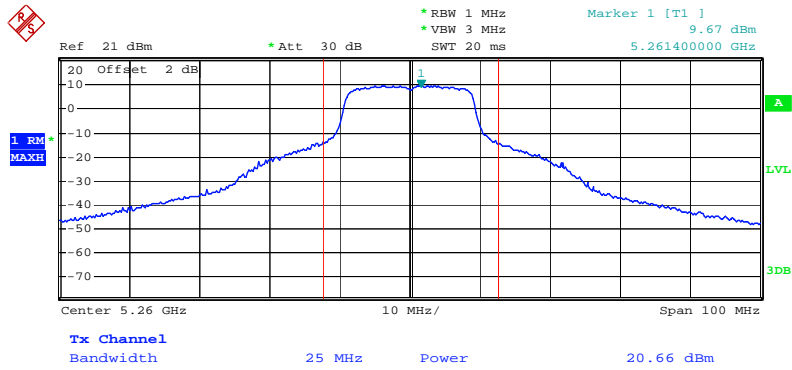

Date: 14.SEP.2009 21:43:32

**Conducted Output Power Plot on Configuration 802.11n MCS8 20MHz Ant. 3-3 / 5300 MHz**

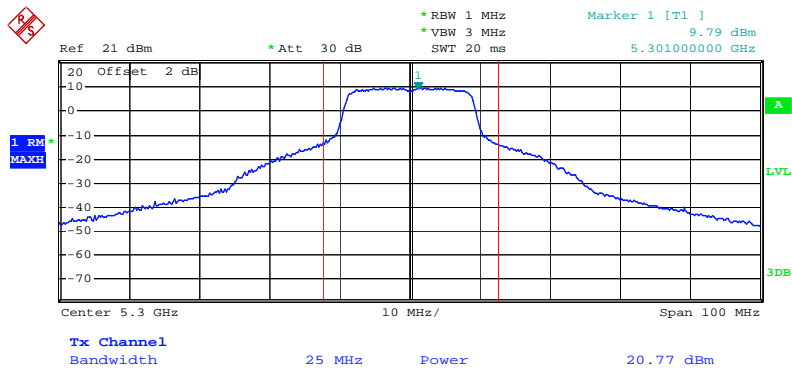

Date: 14.SEP.2009 21:47:08

### Conducted Output Power Plot on Configuration 802.11n MCS8 20MHz Ant. 3-3 / 5320 MHz

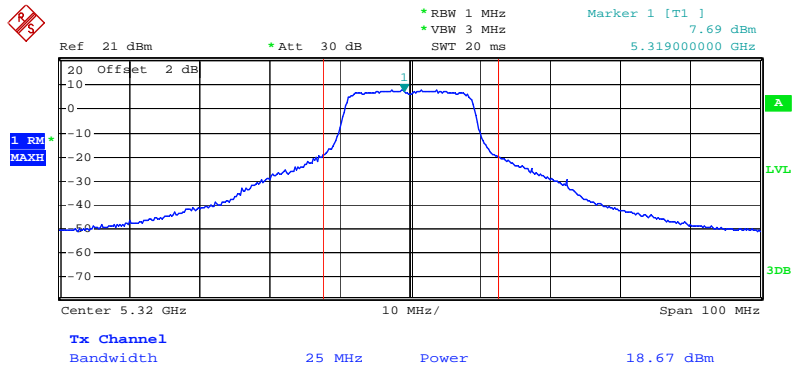

Date: 14.SEP.2009 21:49:48

### Conducted Output Power Plot on Configuration 802.11n MCS8 20MHz Ant. 3-3 / 5500 MHz

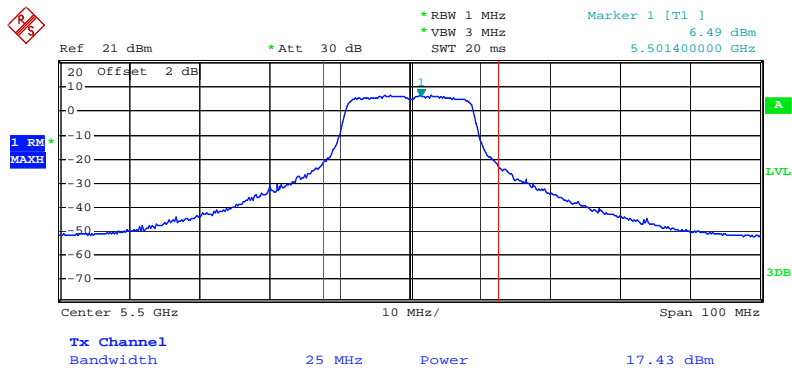

Date: 14.SEP.2009 21:57:43

### Conducted Output Power Plot on Configuration 802.11n MCS8 20MHz Ant. 3-3 / 5580 MHz

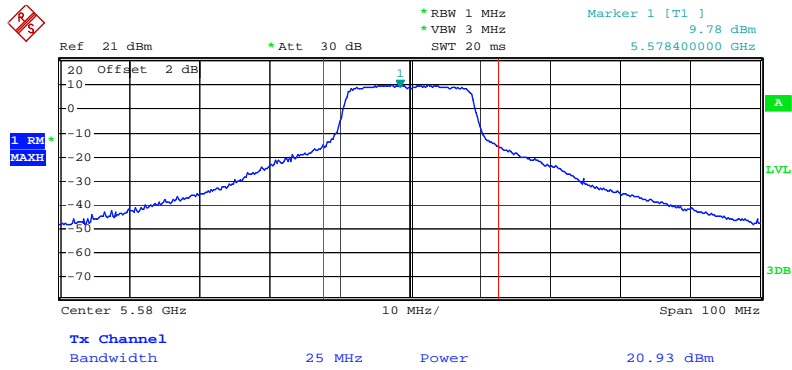

Date: 14.SEP.2009 21:59:55

### Conducted Output Power Plot on Configuration 802.11n MCS8 20MHz Ant. 3-3 / 5700 MHz

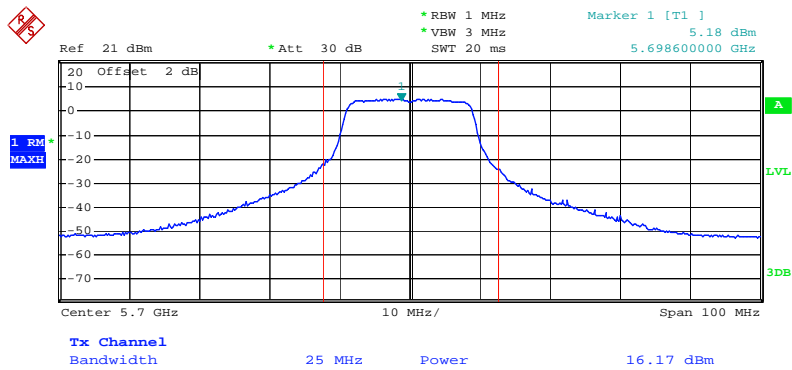

Date: 14.SEP.2009 22:02:50

**Conducted Output Power Plot on Configuration 802.11n MCS8 40MHz Ant. 3-1 / 5270 MHz**

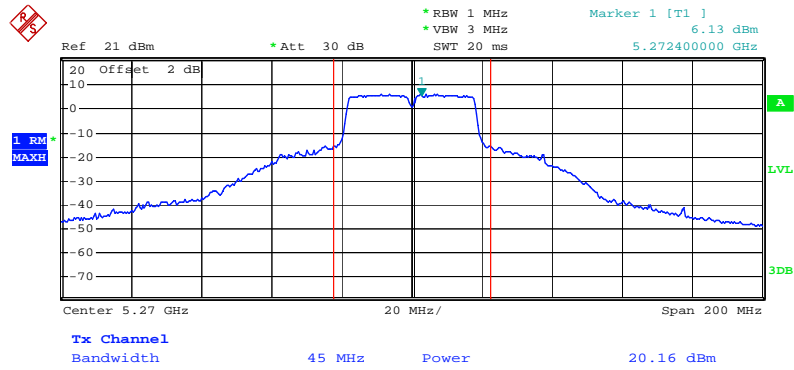

Date: 14.SEP.2009 22:42:26

**Conducted Output Power Plot on Configuration 802.11n MCS8 40MHz Ant. 3-1 / 5310 MHz**

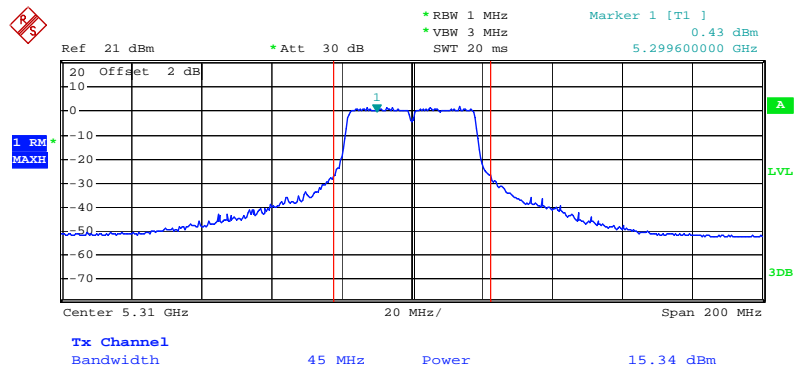

Date: 14.SEP.2009 22:46:43

## Conducted Output Power Plot on Configuration 802.11n MCS8 40MHz Ant. 3-1 / 5510MHz

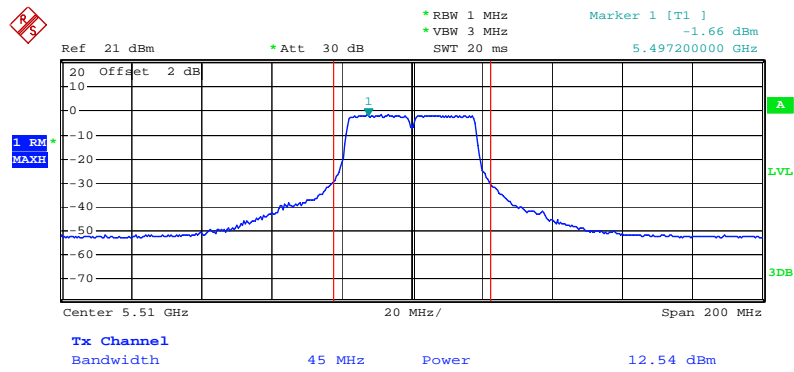

Date: 14.SEP.2009 22:50:28

## Conducted Output Power Plot on Configuration 802.11n MCS8 40MHz Ant. 3-1 / 5550 MHz

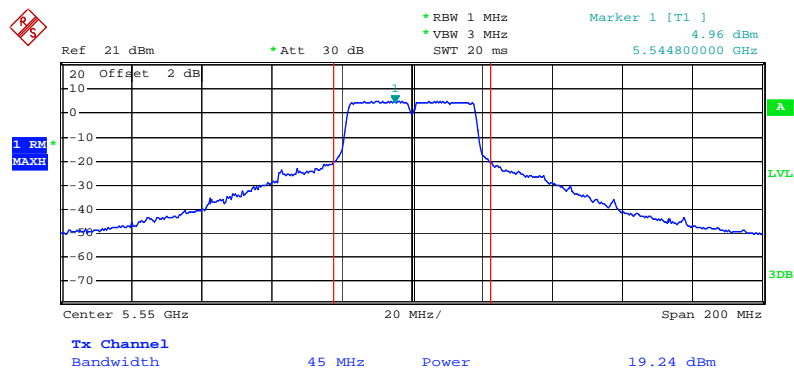

Date: 14.SEP.2009 23:00:44

### Conducted Output Power Plot on Configuration 802.11n MCS8 40MHz Ant. 3-1 / 5670 MHz

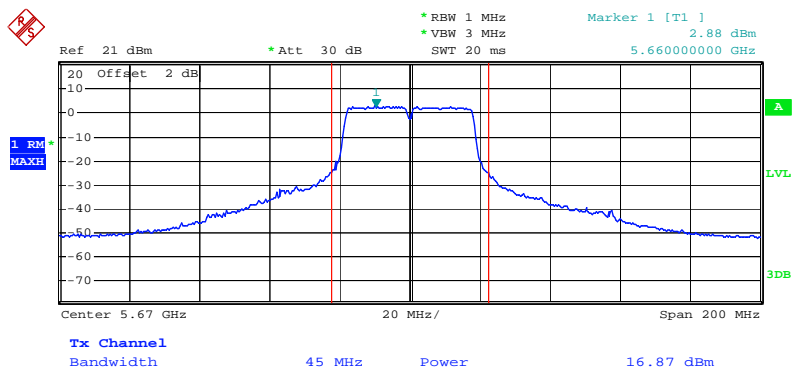

Date: 14.SEP.2009 22:57:18

### Conducted Output Power Plot on Configuration 802.11n MCS8 40MHz Ant. 3-3 / 5270 MHz

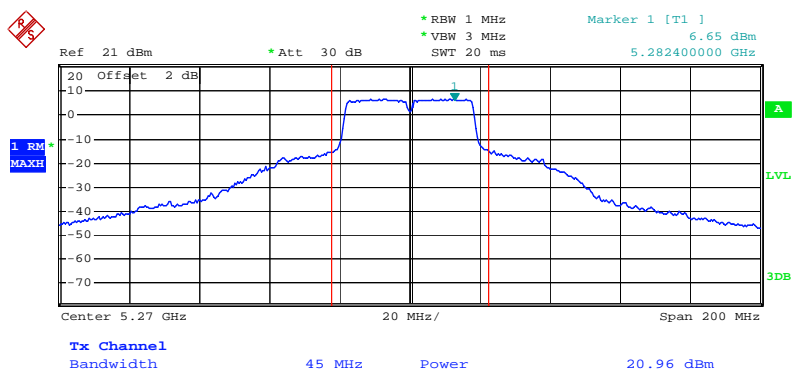

Date: 14.SEP.2009 23:19:24

**Conducted Output Power Plot on Configuration 802.11n MCS8 40MHz Ant. 3-3 / 5310 MHz**

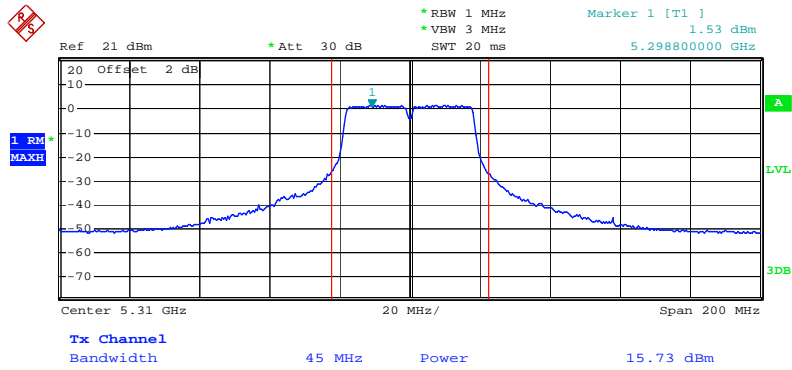

Date: 14.SEP.2009 23:15:30

**Conducted Output Power Plot on Configuration 802.11n MCS8 40MHz Ant. 3-3 / 5510MHz**

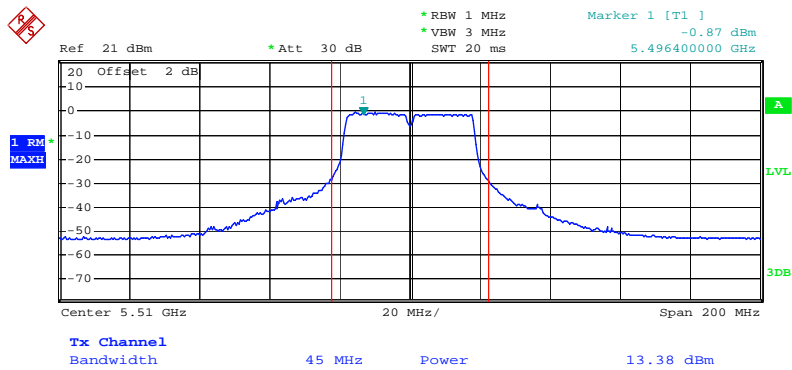

Date: 14.SEP.2009 23:10:41



### Conducted Output Power Plot on Configuration 802.11n MCS8 40MHz Ant. 3-3 / 5550 MHz

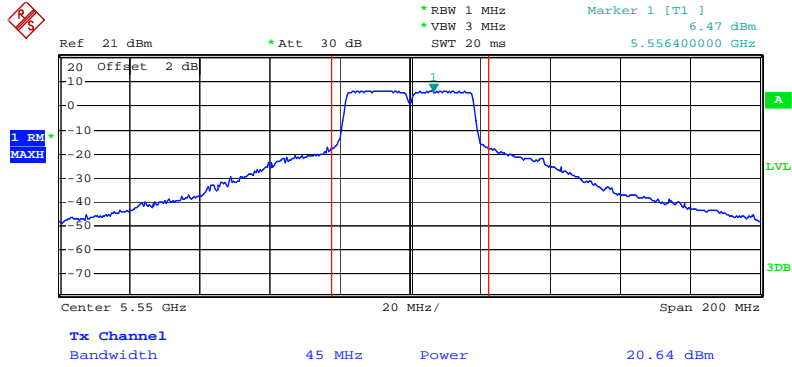

Date: 14.SEP.2009 23:02:28

### Conducted Output Power Plot on Configuration 802.11n MCS8 40MHz Ant. 3-3 / 5670 MHz

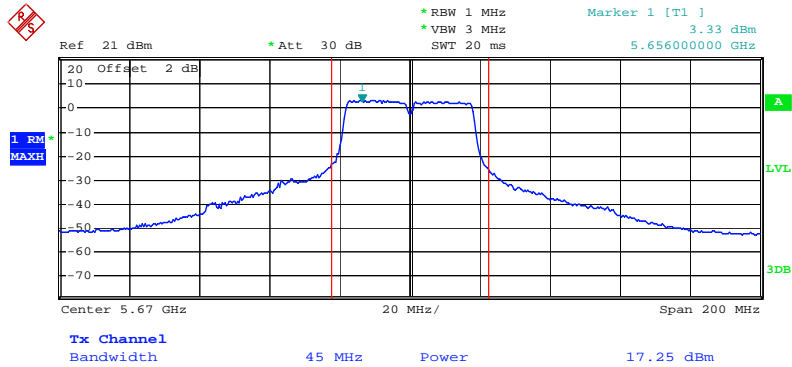

Date: 14.SEP.2009 23:07:49

### Conducted Output Power Plot on Configuration IEEE 802.11a Ant. 3-1 / 5260 MHz

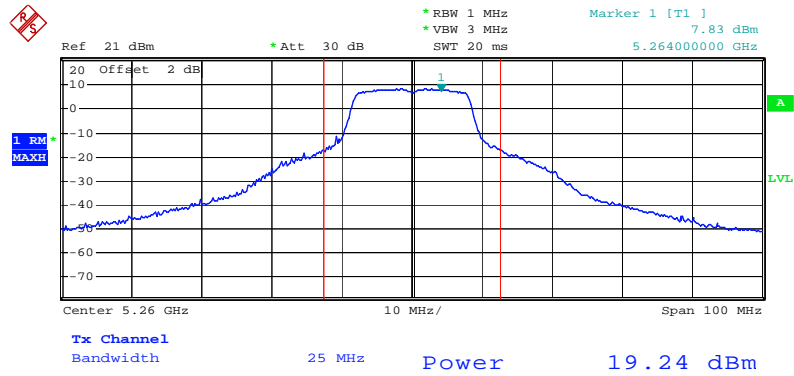

Date: 16.SEP.2009 21:22:16

### Conducted Output Power Plot on Configuration IEEE 802.11a Ant. 3-1 / 5300 MHz

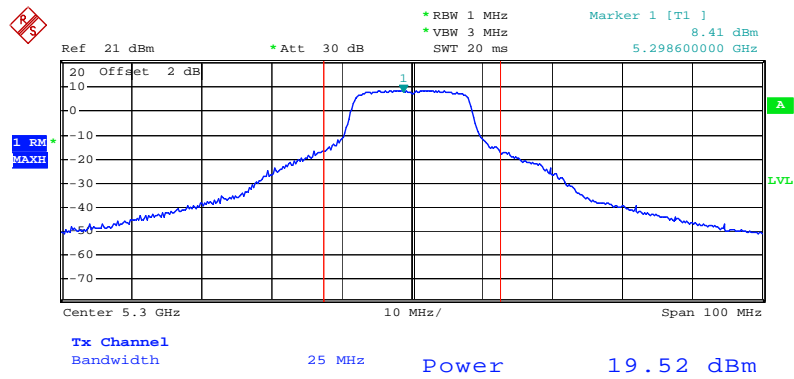

Date: 16.SEP.2009 21:25:17

**Conducted Output Power Plot on Configuration IEEE 802.11a Ant. 3-1 / 5320 MHz**

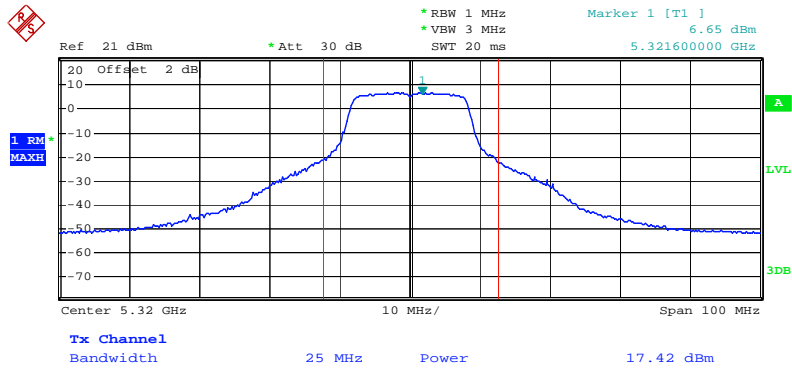

Date: 14.SEP.2009 20:48:05

**Conducted Output Power Plot on Configuration IEEE 802.11a Ant. 3-1 / 5500 MHz**

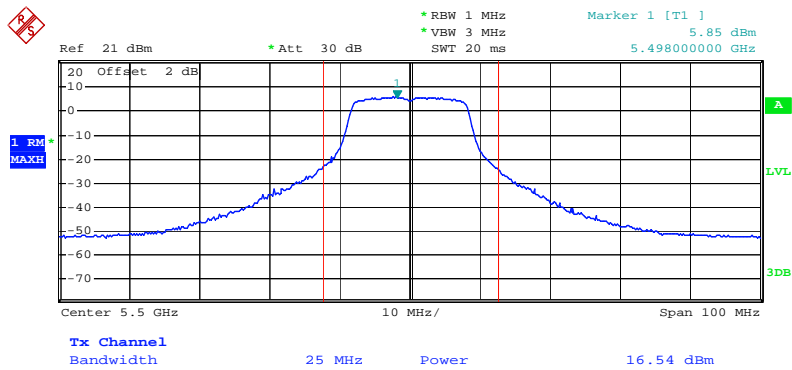

Date: 14.SEP.2009 20:52:10



### Conducted Output Power Plot on Configuration IEEE 802.11a Ant. 3-3 / 5260 MHz

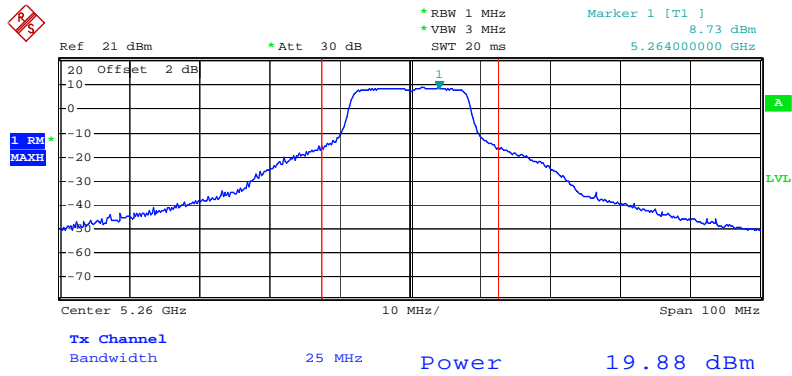

Date: 16.SEP.2009 21:21:57

### Conducted Output Power Plot on Configuration IEEE 802.11a Ant. 3-3 / 5300 MHz

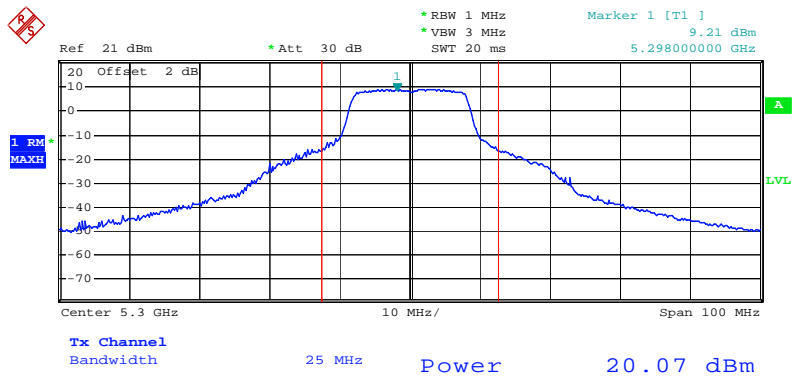

Date: 16.SEP.2009 21:25:32

**Conducted Output Power Plot on Configuration IEEE 802.11a Ant. 3-3 / 5320 MHz**

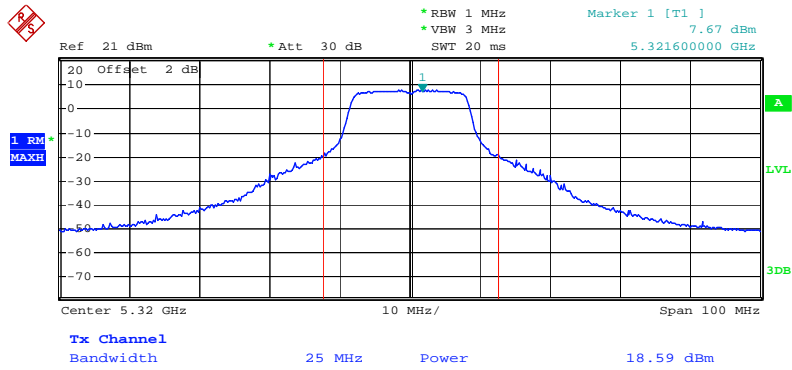

Date: 14.SEP.2009 21:12:17

**Conducted Output Power Plot on Configuration IEEE 802.11a Ant. 3-3 / 5500 MHz**

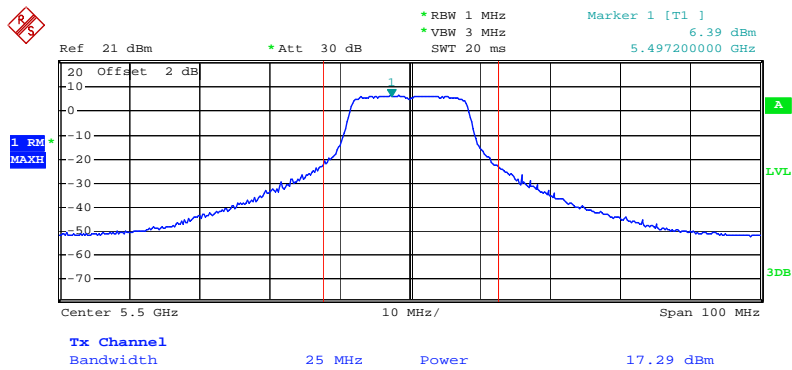

Date: 14.SEP.2009 21:07:20

### Conducted Output Power Plot on Configuration IEEE 802.11a Ant. 3-3 / 5580 MHz

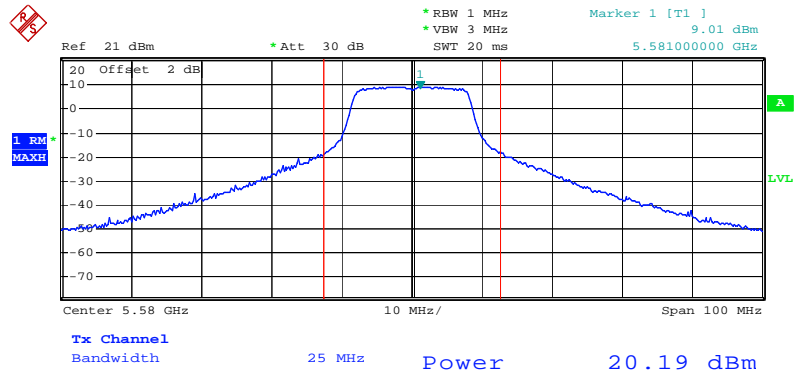

Date: 16.SEP.2009 21:27:24

### Conducted Output Power Plot on Configuration IEEE 802.11a Ant. 3-3 / 5700 MHz

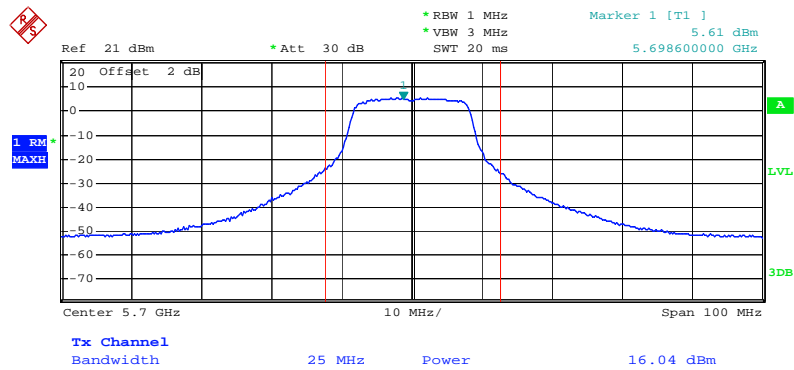

Date: 14.SEP.2009 20:56:48

<For Antenna 4>:

**Conducted Output Power Plot on Configuration 802.11n MCS8 20MHz Ant. 4-1 / 5260 MHz**

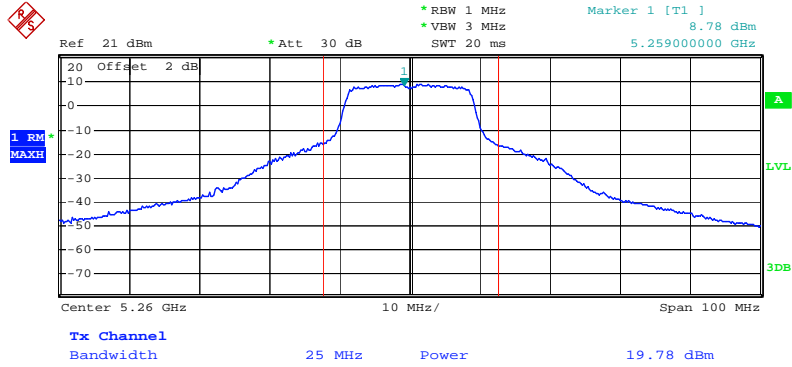

Date: 14.SEP.2009 22:21:00

**Conducted Output Power Plot on Configuration 802.11n MCS8 20MHz Ant. 4-1 / 5300 MHz**

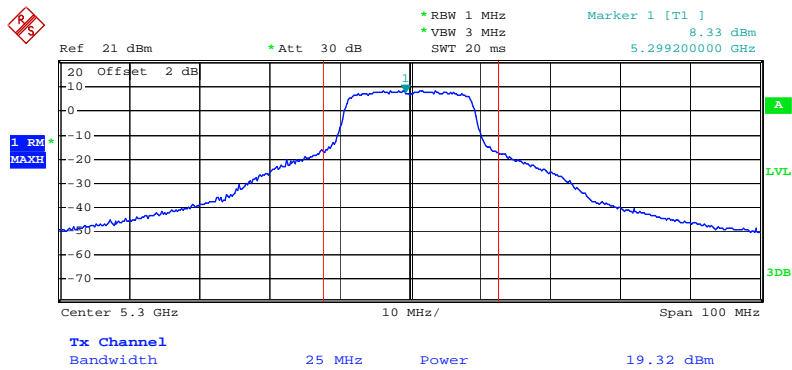

Date: 14.SEP.2009 22:17:45

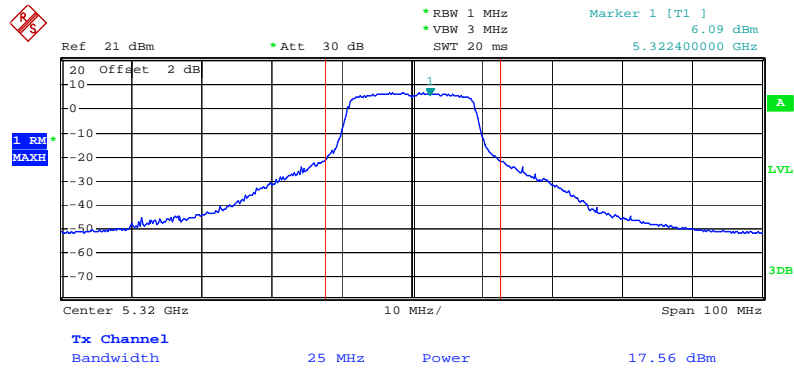

**Conducted Output Power Plot on Configuration 802.11n MCS8 20MHz Ant. 4-1 / 5320 MHz**

Date: 14.SEP.2009 22:15:32

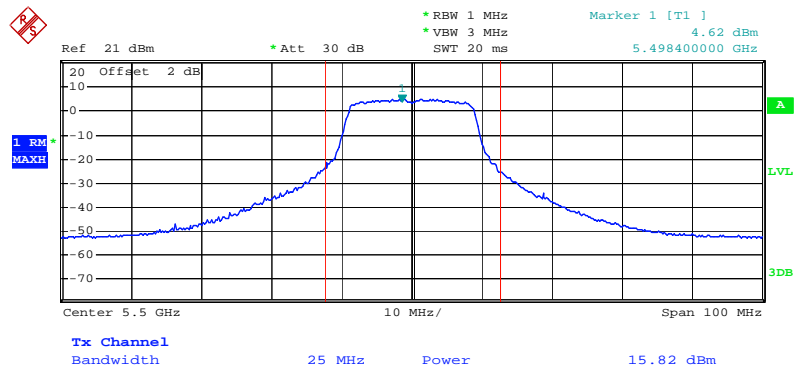
**Conducted Output Power Plot on Configuration 802.11n MCS8 20MHz Ant. 4-1 / 5500 MHz**

Date: 14.SEP.2009 22:12:23

### Conducted Output Power Plot on Configuration 802.11n MCS8 20MHz Ant. 4-1 / 5580 MHz

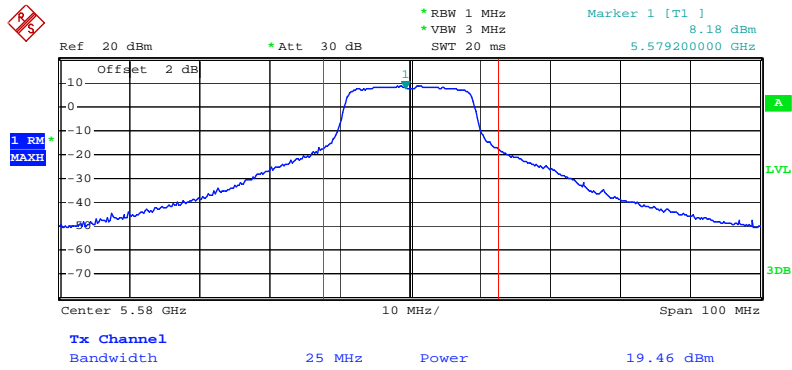

Date: 15.SEP.2009 16:30:36

### Conducted Output Power Plot on Configuration 802.11n MCS8 20MHz Ant. 4-1 / 5700 MHz

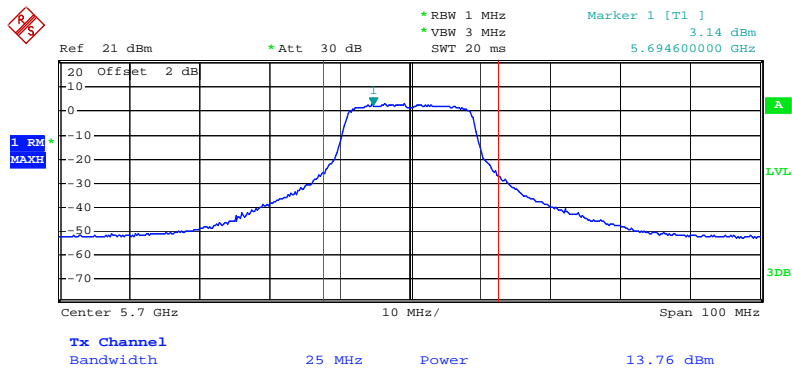

Date: 14.SEP.2009 22:06:36

**Conducted Output Power Plot on Configuration 802.11n MCS8 20MHz Ant. 4-3 / 5260 MHz**

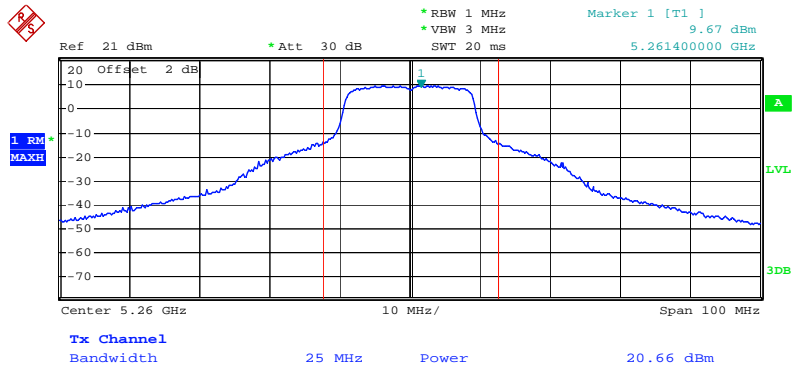

Date: 14.SEP.2009 21:43:32

**Conducted Output Power Plot on Configuration 802.11n MCS8 20MHz Ant. 4-3 / 5300 MHz**

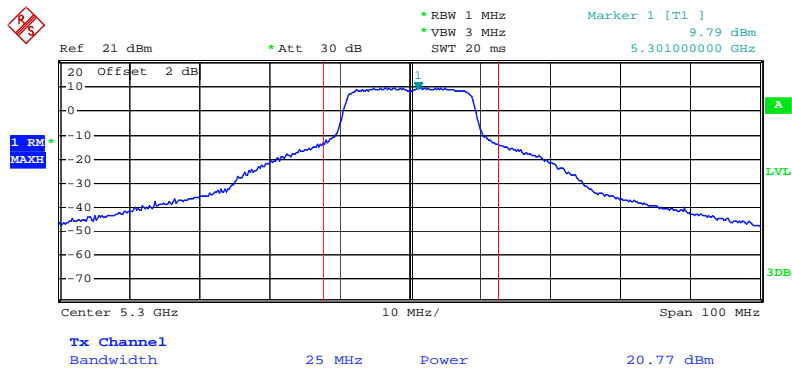

Date: 14.SEP.2009 21:47:08

**Conducted Output Power Plot on Configuration 802.11n MCS8 20MHz Ant. 4-3 / 5320 MHz**

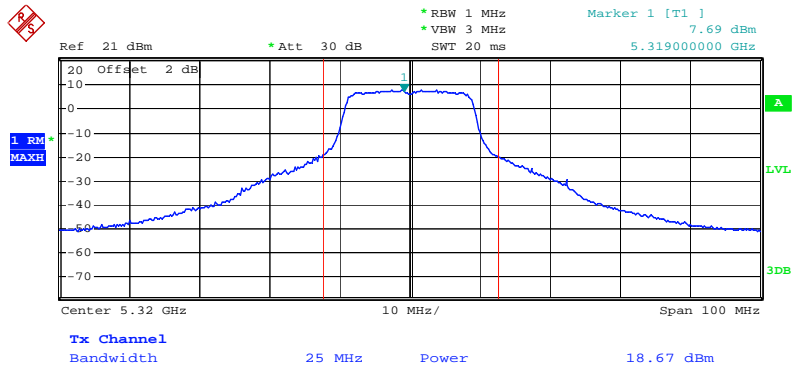

Date: 14.SEP.2009 21:49:48

**Conducted Output Power Plot on Configuration 802.11n MCS8 20MHz Ant. 4-3 / 5500 MHz**

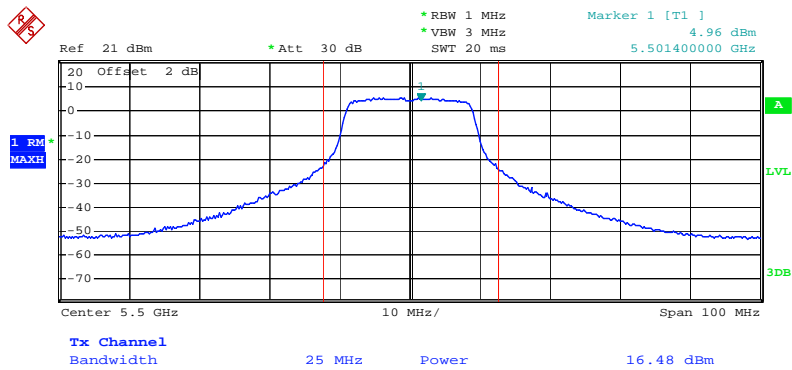

Date: 14.SEP.2009 21:58:24

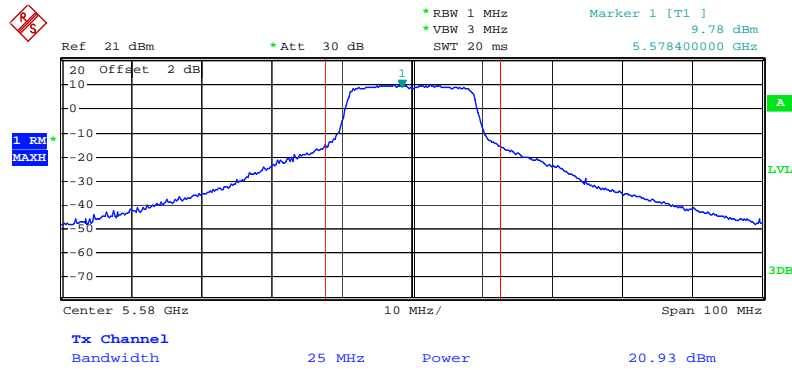
**Conducted Output Power Plot on Configuration 802.11n MCS8 20MHz Ant. 4-3 / 5580 MHz**

Date: 14.SEP.2009 21:59:55

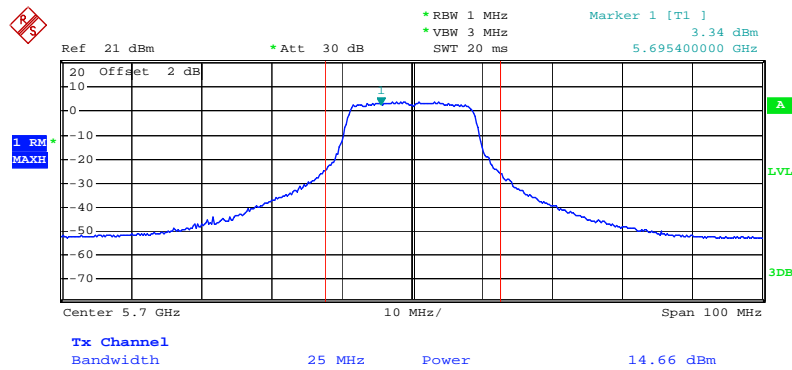
**Conducted Output Power Plot on Configuration 802.11n MCS8 20MHz Ant. 4-3 / 5700 MHz**

Date: 14.SEP.2009 22:01:03

### Conducted Output Power Plot on Configuration 802.11n MCS8 40MHz Ant. 4-1 / 5270 MHz

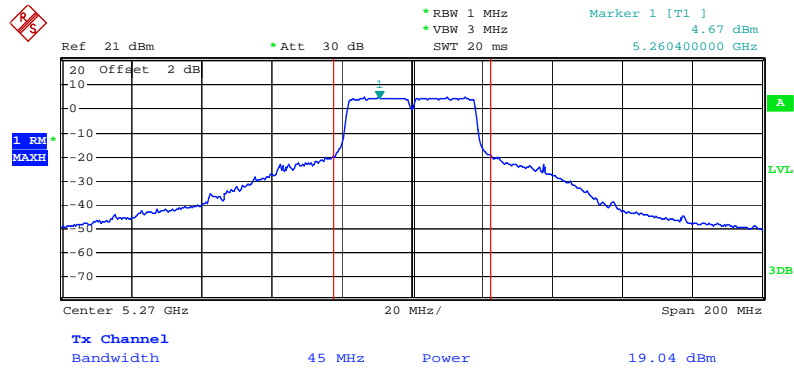

Date: 14.SEP.2009 22:43:45

### Conducted Output Power Plot on Configuration 802.11n MCS8 40MHz Ant. 4-1 / 5310 MHz

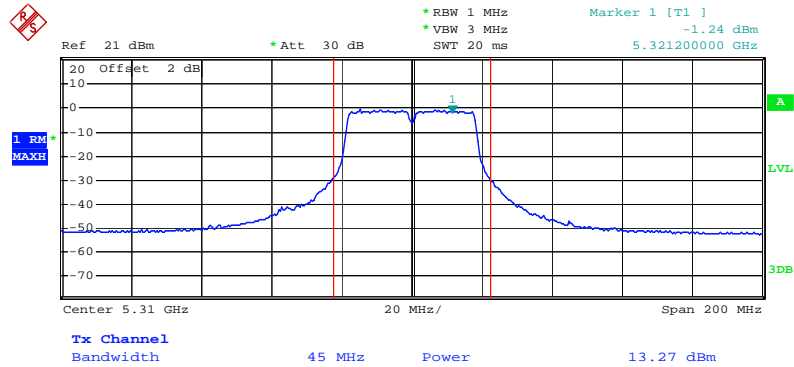

Date: 14.SEP.2009 22:46:02

**Conducted Output Power Plot on Configuration 802.11n MCS8 40MHz Ant. 4-1 / 5510MHz**

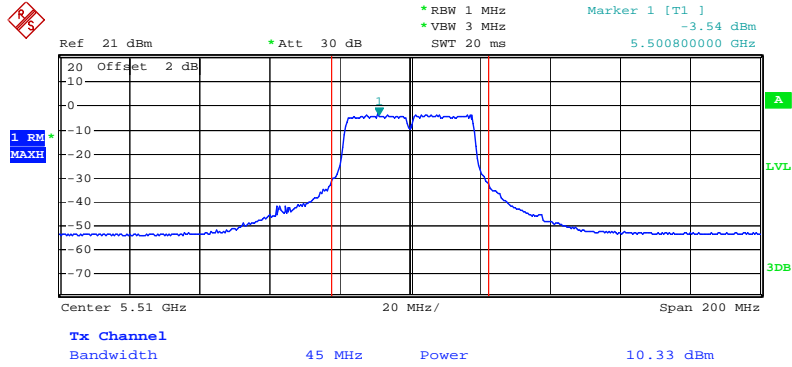

Date: 14.SEP.2009 22:51:10

**Conducted Output Power Plot on Configuration 802.11n MCS8 40MHz Ant. 4-1 / 5550 MHz**

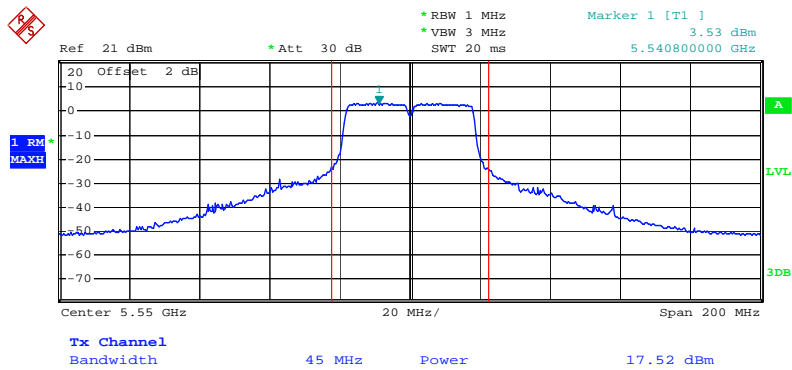

Date: 14.SEP.2009 23:00:10

### Conducted Output Power Plot on Configuration 802.11n MCS8 40MHz Ant. 4-1 / 5670 MHz

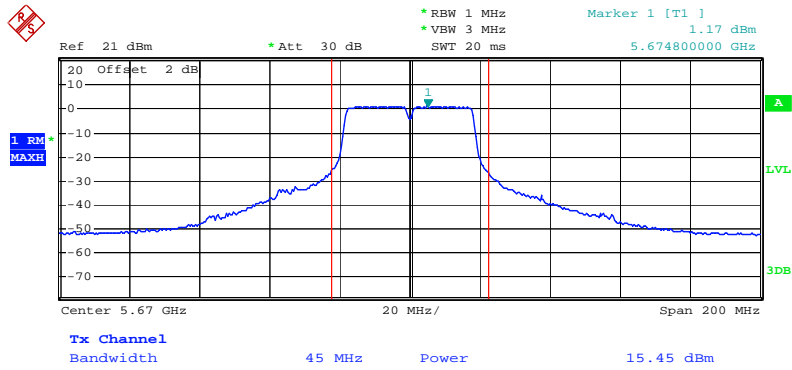

Date: 14.SEP.2009 22:55:53

### Conducted Output Power Plot on Configuration 802.11n MCS8 40MHz Ant. 4-3 / 5270 MHz

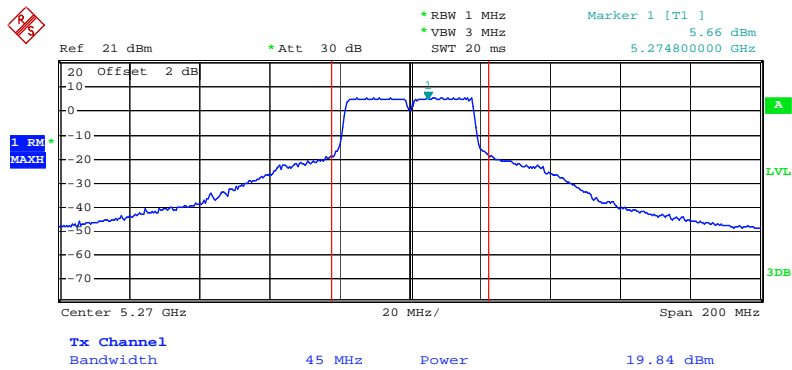

Date: 14.SEP.2009 23:17:43



### Conducted Output Power Plot on Configuration 802.11n MCS8 40MHz Ant. 4-3 / 5310 MHz

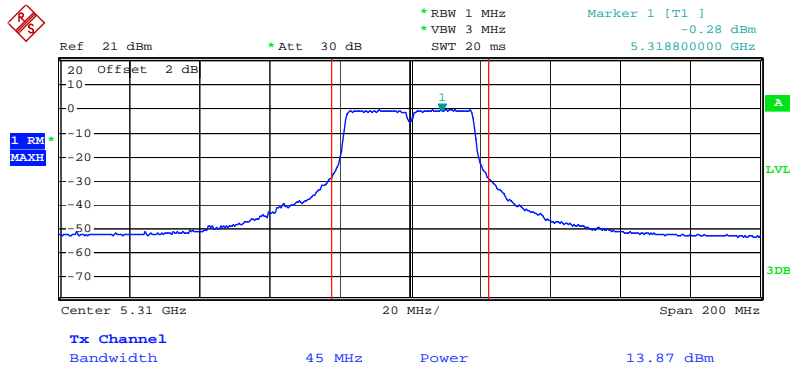

Date: 14.SEP.2009 23:16:01

### Conducted Output Power Plot on Configuration 802.11n MCS8 40MHz Ant. 4-3 / 5510MHz

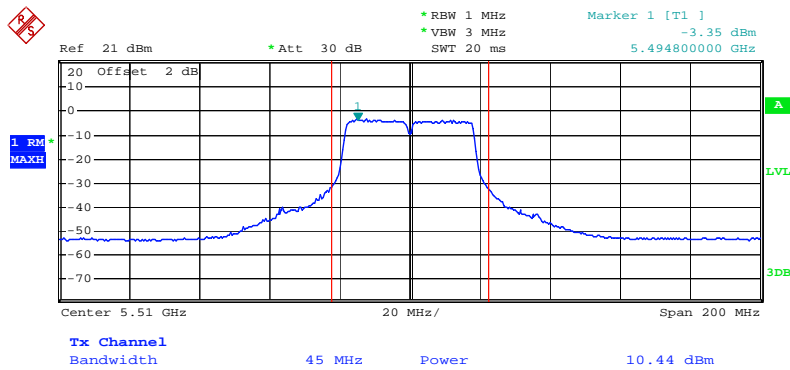

Date: 14.SEP.2009 23:11:15

### Conducted Output Power Plot on Configuration 802.11n MCS8 40MHz Ant. 4-3 / 5550 MHz

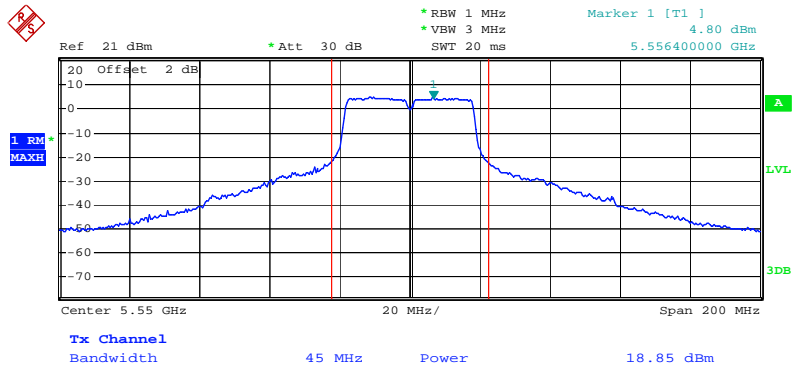

Date: 14.SEP.2009 23:03:28

### Conducted Output Power Plot on Configuration 802.11n MCS8 40MHz Ant. 4-3 / 5670 MHz

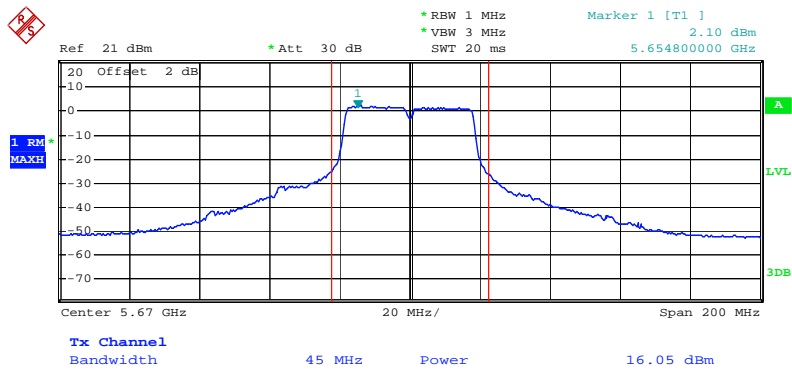

Date: 14.SEP.2009 23:06:52

## Conducted Output Power Plot on Configuration IEEE 802.11a Ant. 4-1 / 5260 MHz

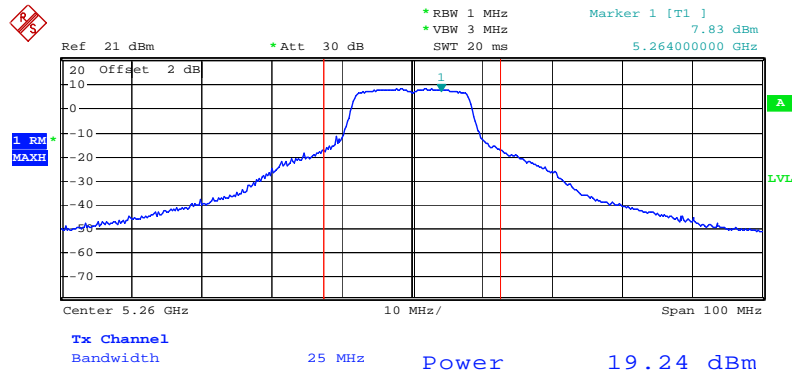

Date: 16.SEP.2009 21:22:16

## Conducted Output Power Plot on Configuration IEEE 802.11a Ant. 4-1 / 5300 MHz

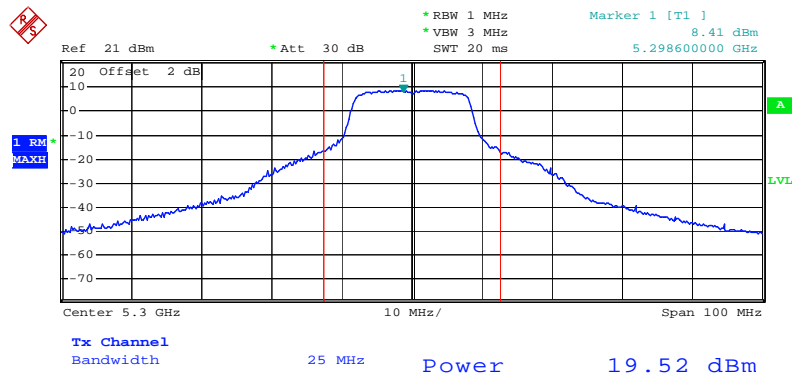

Date: 16.SEP.2009 21:25:17

### Conducted Output Power Plot on Configuration IEEE 802.11a Ant. 4-1 / 5320 MHz

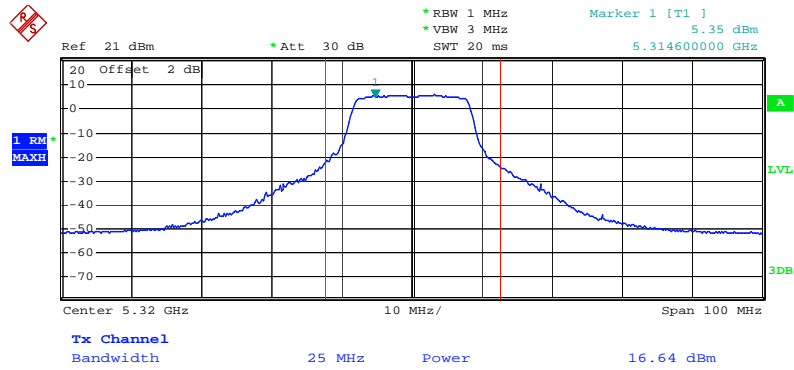

Date: 14.SEP.2009 20:48:34

### Conducted Output Power Plot on Configuration IEEE 802.11a Ant. 4-1 / 5500 MHz

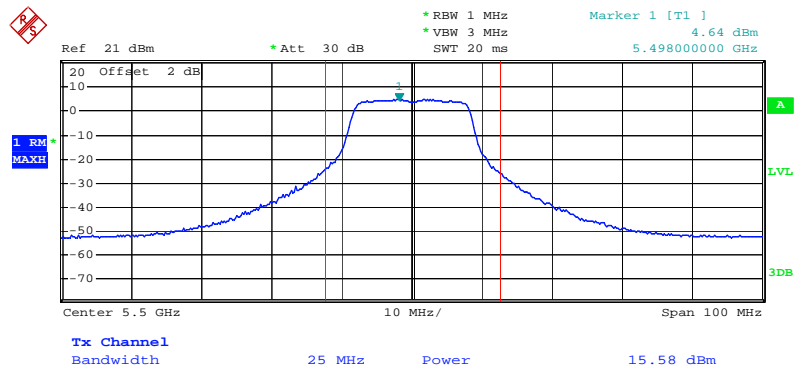

Date: 14.SEP.2009 20:52:44

### Conducted Output Power Plot on Configuration IEEE 802.11a Ant. 4-1 / 5580 MHz

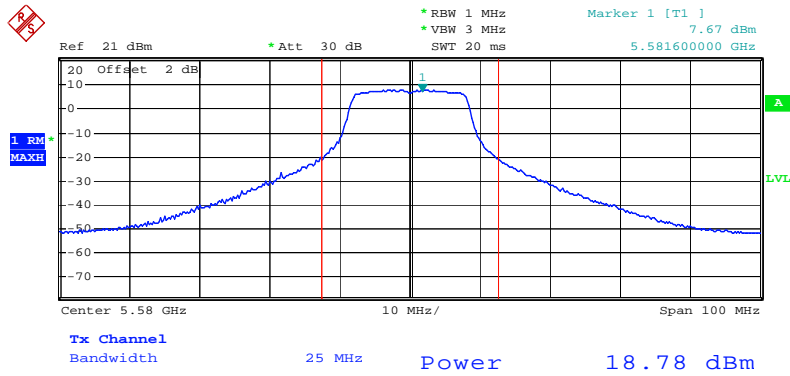

Date: 16.SEP.2009 21:27:49

### Conducted Output Power Plot on Configuration IEEE 802.11a Ant. 4-1 / 5700 MHz

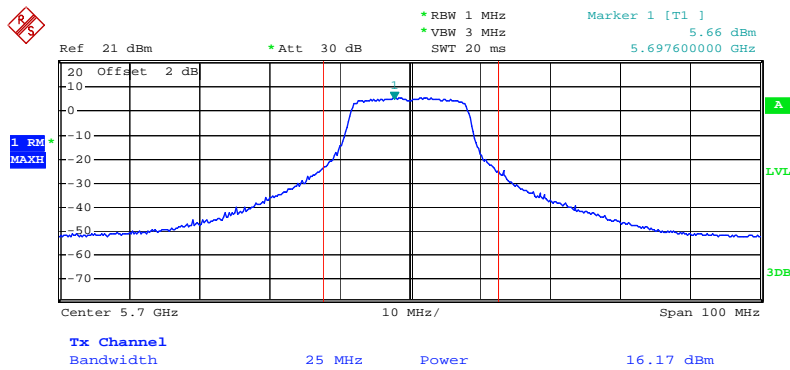

Date: 14.SEP.2009 20:57:21

Conducted Output Power Plot on Configuration IEEE 802.11a Ant. 4-3 / 5260 MHz

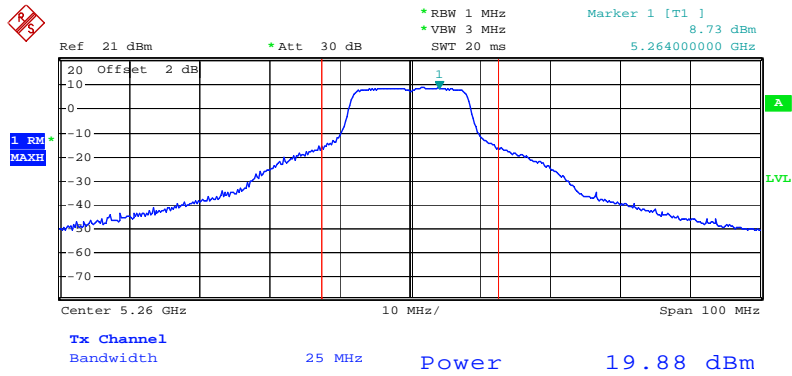

Date: 16.SEP.2009 21:21:57

Conducted Output Power Plot on Configuration IEEE 802.11a Ant. 4-3 / 5300 MHz

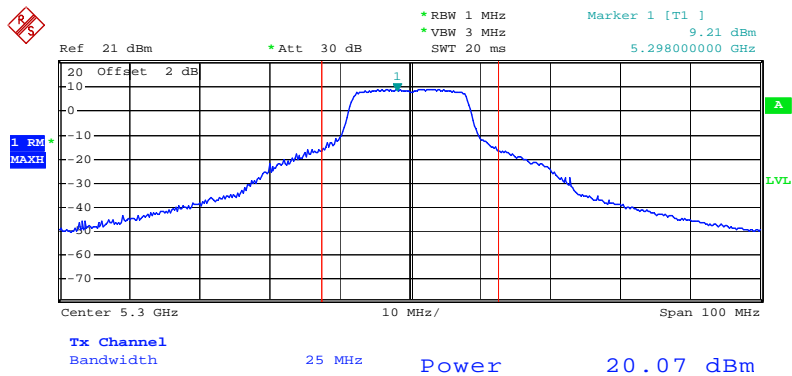

Date: 16.SEP.2009 21:25:32

**Conducted Output Power Plot on Configuration IEEE 802.11a Ant. 4-3 / 5320 MHz**

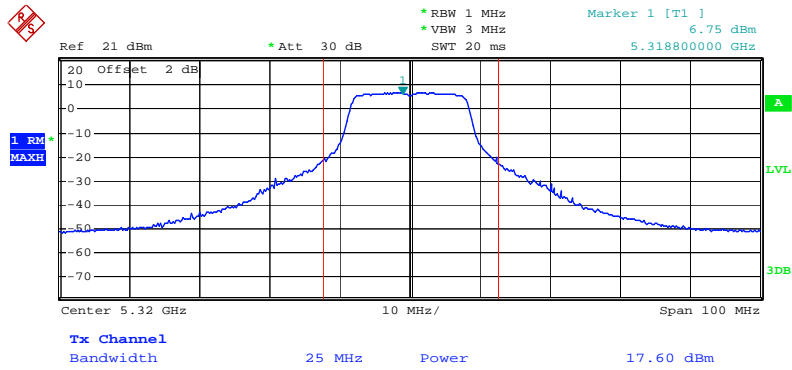

Date: 14.SEP.2009 21:12:59

**Conducted Output Power Plot on Configuration IEEE 802.11a Ant. 4-3 / 5500 MHz**

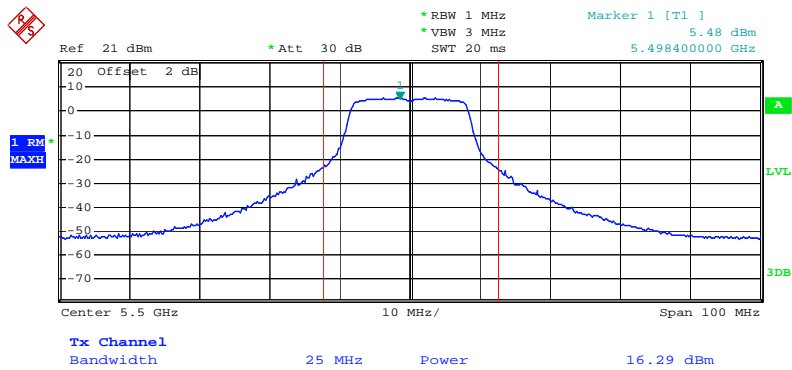

Date: 14.SEP.2009 21:06:49

### Conducted Output Power Plot on Configuration IEEE 802.11a Ant. 4-3 / 5580 MHz

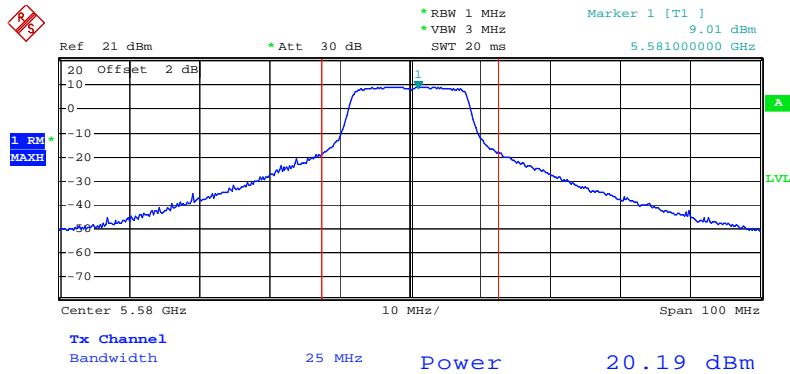

Date: 16.SEP.2009 21:27:24

### Conducted Output Power Plot on Configuration IEEE 802.11a Ant. 4-3 / 5700 MHz

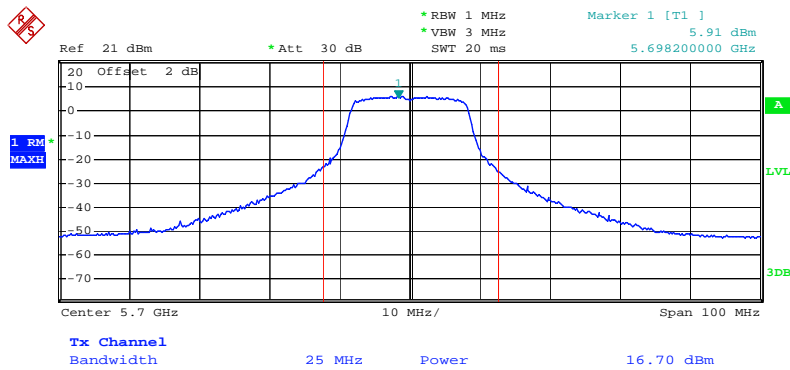

Date: 14.SEP.2009 21:00:56



<For Antenna 5>:

**Conducted Output Power Plot on Configuration 802.11n MCS8 20MHz Ant. 5-1 / 5260 MHz**

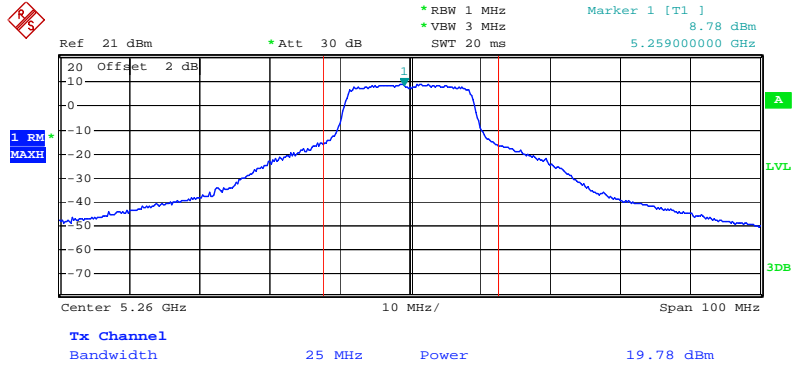

Date: 14.SEP.2009 22:21:00

**Conducted Output Power Plot on Configuration 802.11n MCS8 20MHz Ant. 5-1 / 5300 MHz**

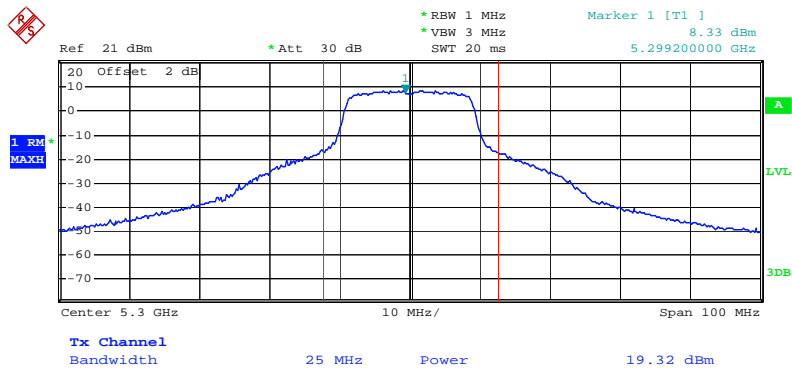

Date: 14.SEP.2009 22:17:45

### Conducted Output Power Plot on Configuration 802.11n MCS8 20MHz Ant. 5-1 / 5320 MHz

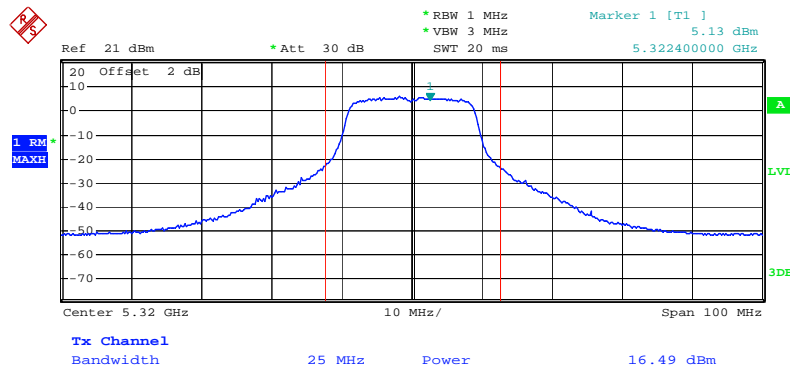

Date: 14.SEP.2009 22:14:47

### Conducted Output Power Plot on Configuration 802.11n MCS8 20MHz Ant. 5-1 / 5500 MHz

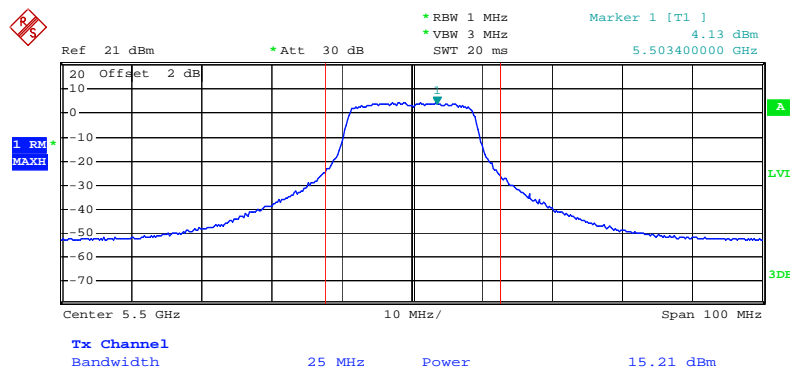

Date: 14.SEP.2009 22:12:55

### Conducted Output Power Plot on Configuration 802.11n MCS8 20MHz Ant. 5-1 / 5580 MHz

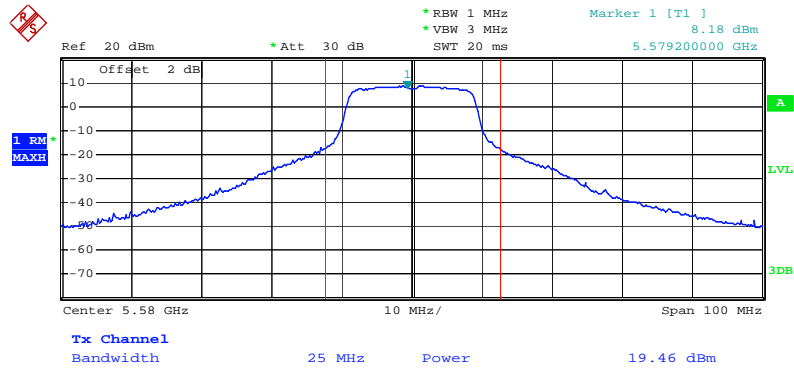

Date: 15.SEP.2009 16:30:36

### Conducted Output Power Plot on Configuration 802.11n MCS8 20MHz Ant. 5-1 / 5700 MHz

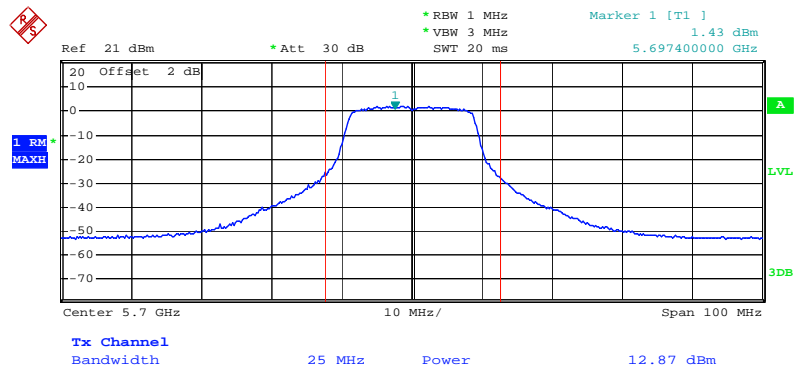

Date: 14.SEP.2009 22:05:42

**Conducted Output Power Plot on Configuration 802.11n MCS8 20MHz Ant. 5-3 / 5260 MHz**

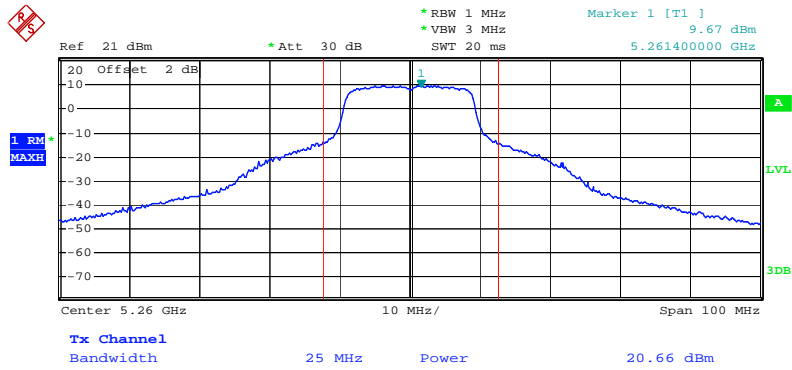

Date: 14.SEP.2009 21:43:32

**Conducted Output Power Plot on Configuration 802.11n MCS8 20MHz Ant. 5-3 / 5300 MHz**

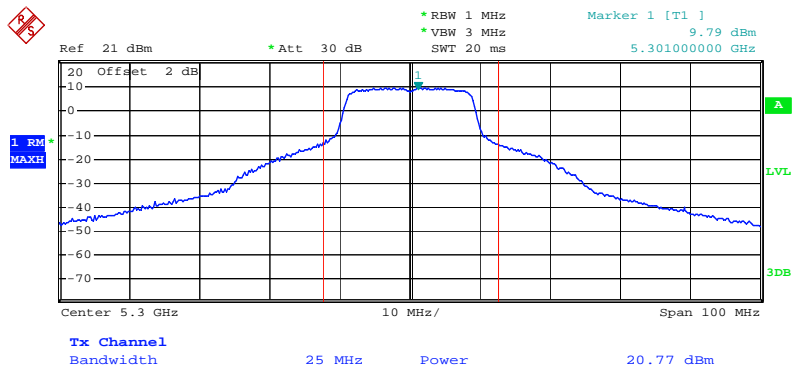

Date: 14.SEP.2009 21:47:08



## Conducted Output Power Plot on Configuration 802.11n MCS8 20MHz Ant. 5-3 / 5580 MHz

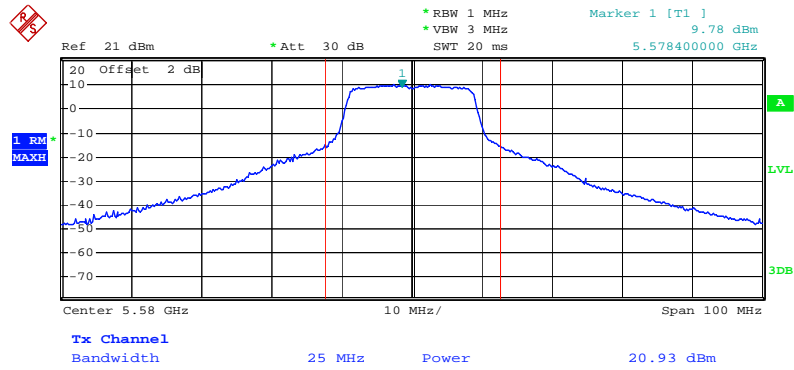

Date: 14.SEP.2009 21:59:55

## Conducted Output Power Plot on Configuration 802.11n MCS8 20MHz Ant. 5-3 / 5700 MHz

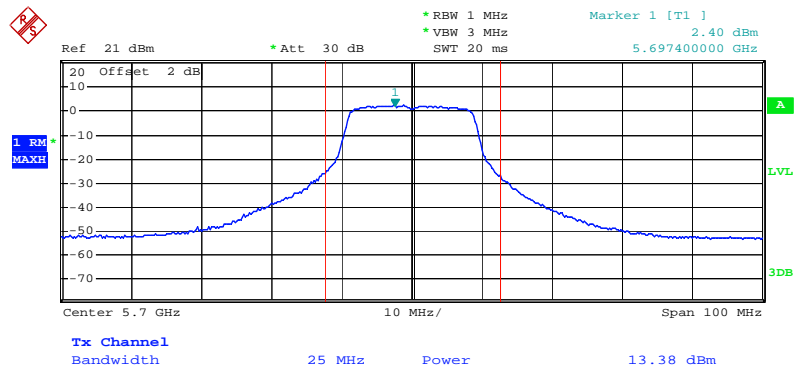

Date: 14.SEP.2009 22:03:37



### Conducted Output Power Plot on Configuration 802.11n MCS8 40MHz Ant. 5-1 / 5510MHz

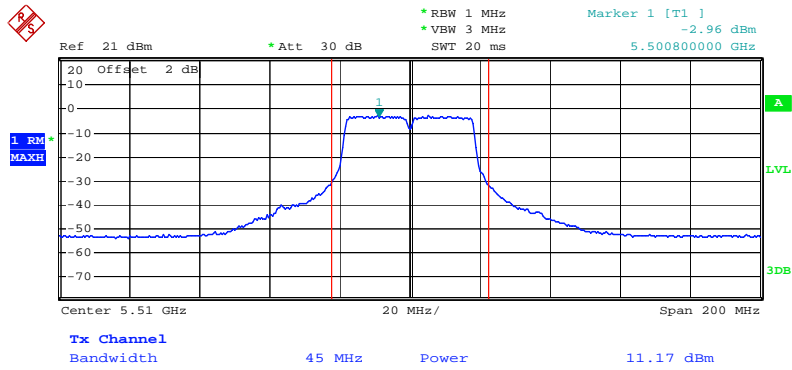

Date: 14.SEP.2009 23:09:19

### Conducted Output Power Plot on Configuration 802.11n MCS8 40MHz Ant. 5-1 / 5550 MHz

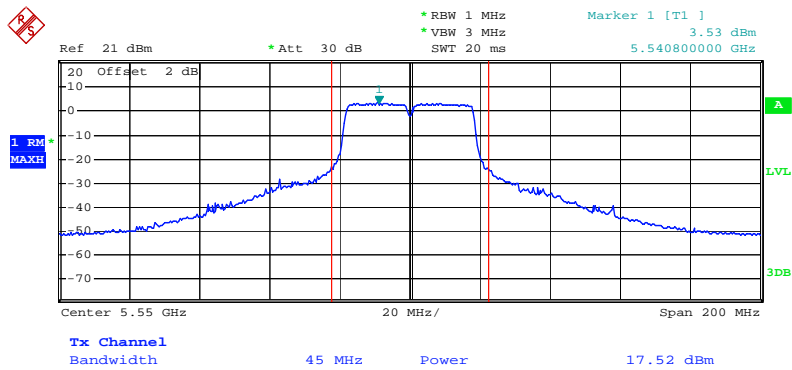

Date: 14.SEP.2009 23:00:10



**Conducted Output Power Plot on Configuration 802.11n MCS8 40MHz Ant. 5-1 / 5670 MHz**

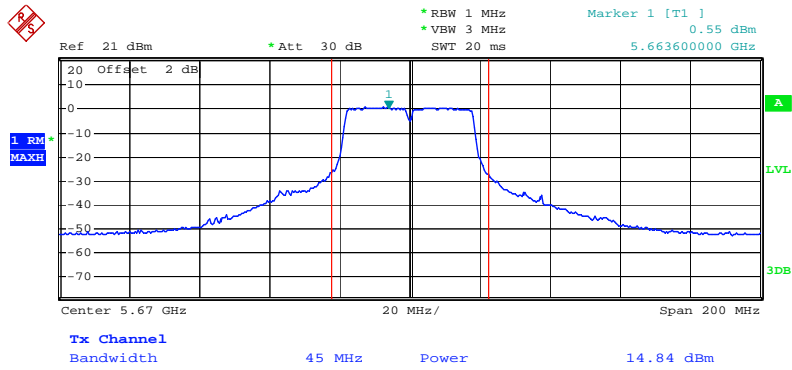

Date: 14.SEP.2009 22:58:01

**Conducted Output Power Plot on Configuration 802.11n MCS8 40MHz Ant. 5-3 / 5270 MHz**

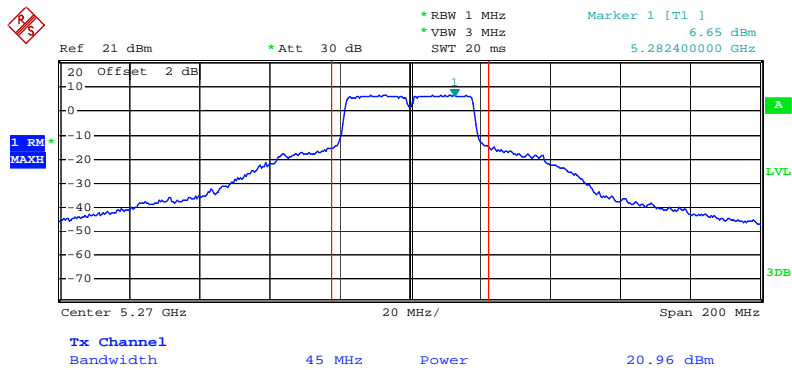

Date: 14.SEP.2009 23:19:24

### Conducted Output Power Plot on Configuration 802.11n MCS8 40MHz Ant. 5-3 / 5310 MHz

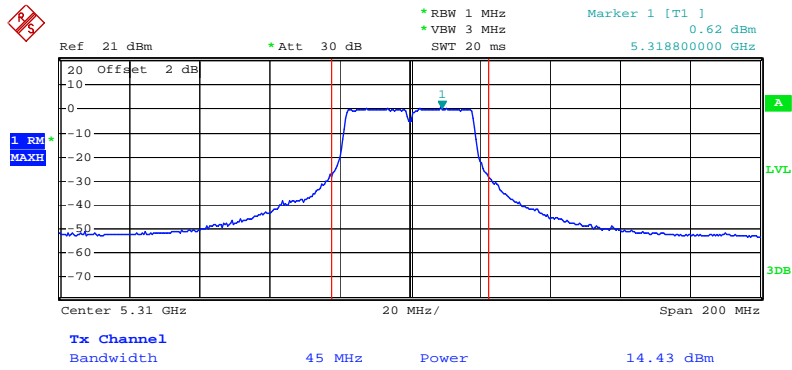

Date: 14.SEP.2009 23:16:30

### Conducted Output Power Plot on Configuration 802.11n MCS8 40MHz Ant. 5-3 / 5510MHz

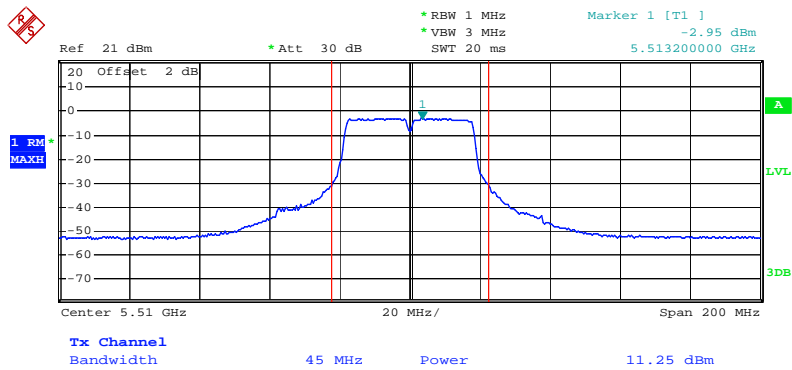

Date: 14.SEP.2009 22:49:14

### Conducted Output Power Plot on Configuration 802.11n MCS8 40MHz Ant. 5-3 / 5550 MHz

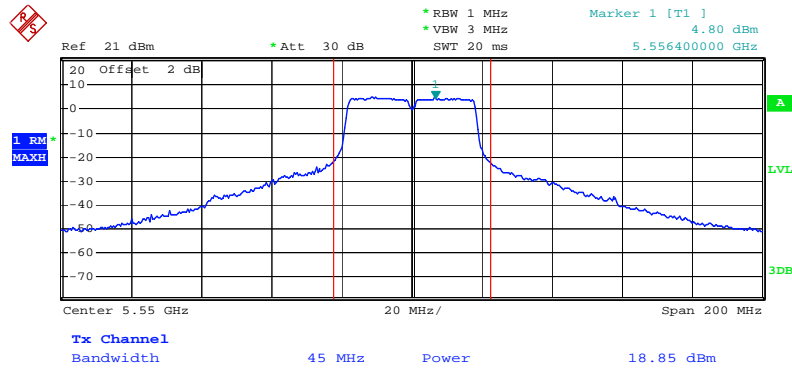

Date: 14.SEP.2009 23:03:28

### Conducted Output Power Plot on Configuration 802.11n MCS8 40MHz Ant. 5-3 / 5670 MHz

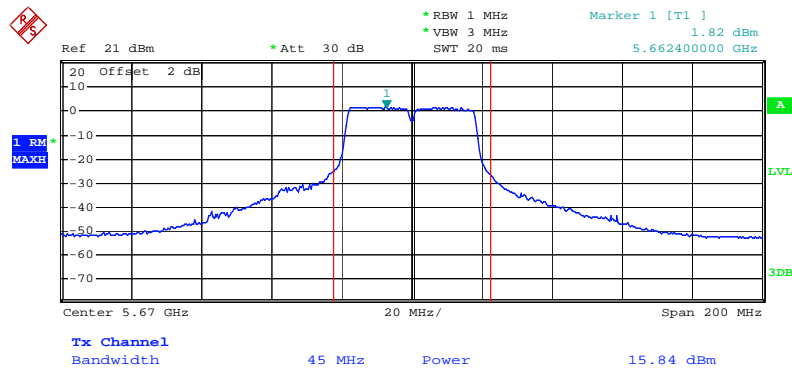

Date: 14.SEP.2009 23:05:32

### Conducted Output Power Plot on Configuration IEEE 802.11a Ant. 5-1 / 5260 MHz

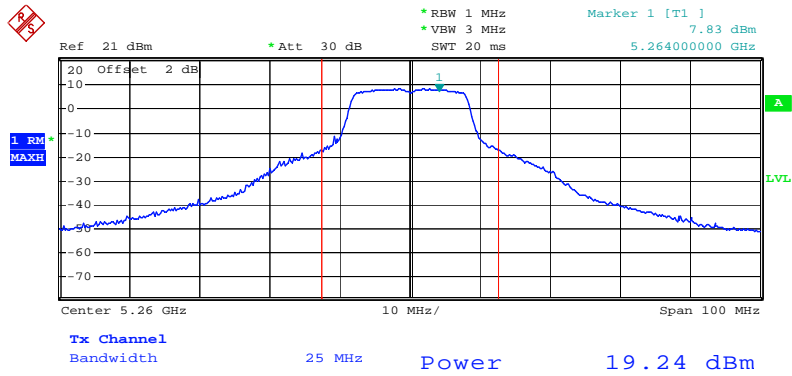

Date: 16.SEP.2009 21:22:16

### Conducted Output Power Plot on Configuration IEEE 802.11a Ant. 5-1 / 5300 MHz

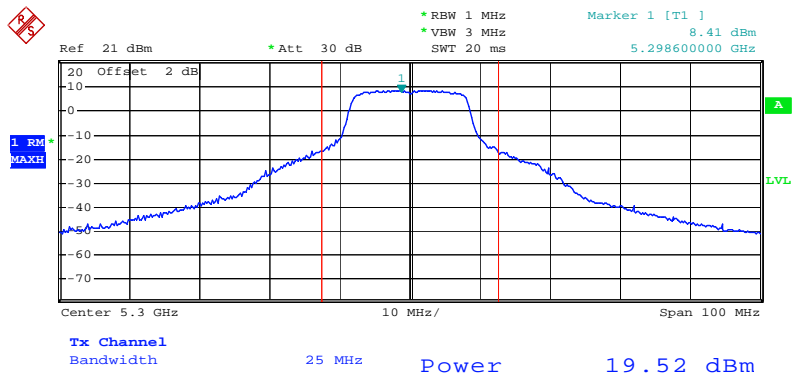

Date: 16.SEP.2009 21:25:17

Conducted Output Power Plot on Configuration IEEE 802.11a Ant. 5-1 / 5320 MHz

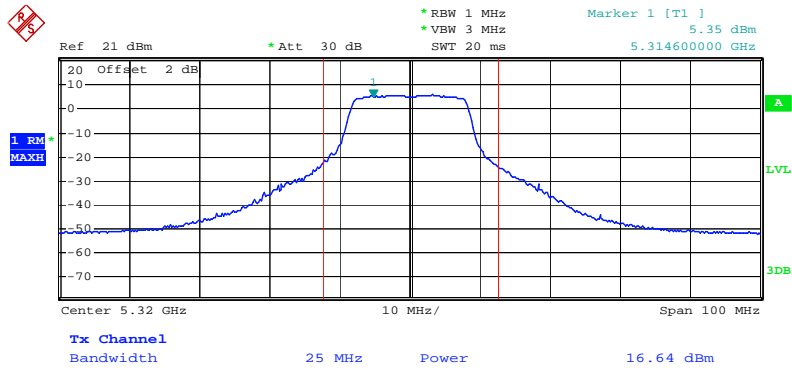

Date: 14.SEP.2009 20:48:34

Conducted Output Power Plot on Configuration IEEE 802.11a Ant. 5-1 / 5500 MHz

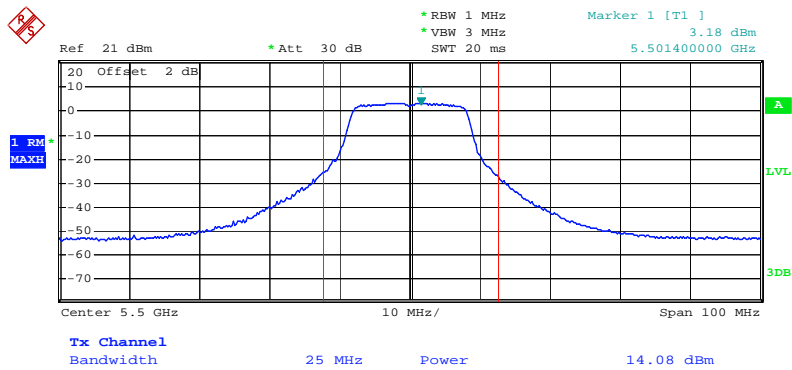

Date: 14.SEP.2009 20:53:19

### Conducted Output Power Plot on Configuration IEEE 802.11a Ant. 5-1 / 5580 MHz

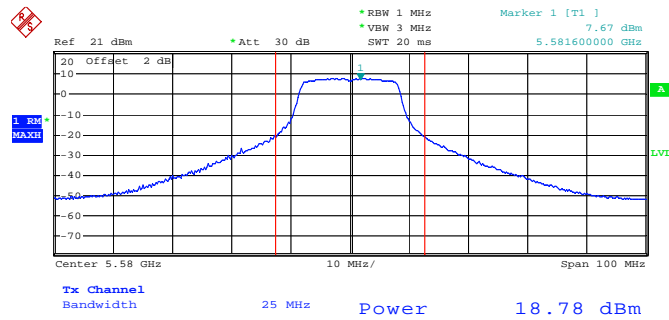

Date: 16.SEP.2009 21:27:49

### Conducted Output Power Plot on Configuration IEEE 802.11a Ant. 5-1 / 5700 MHz

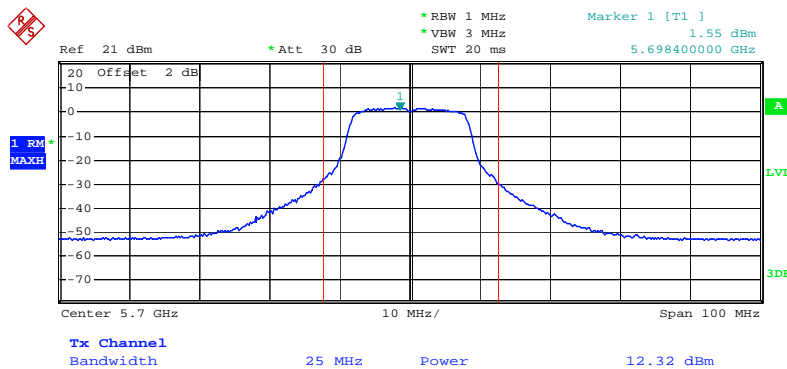

Date: 14.SEP.2009 20:57:55

### Conducted Output Power Plot on Configuration IEEE 802.11a Ant. 5-3 / 5260 MHz

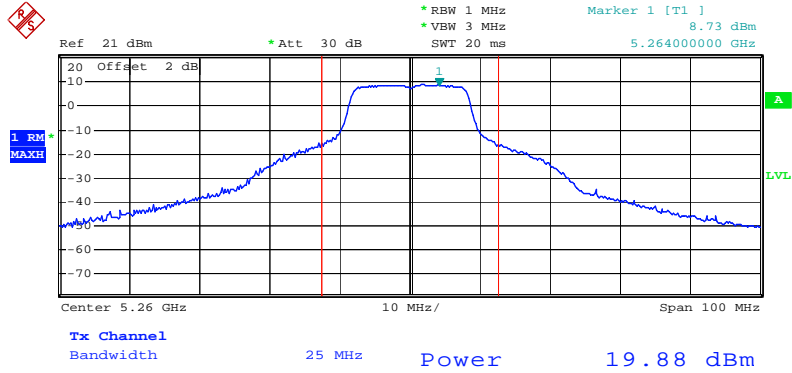

Date: 16.SEP.2009 21:21:57

### Conducted Output Power Plot on Configuration IEEE 802.11a Ant. 5-3 / 5300 MHz

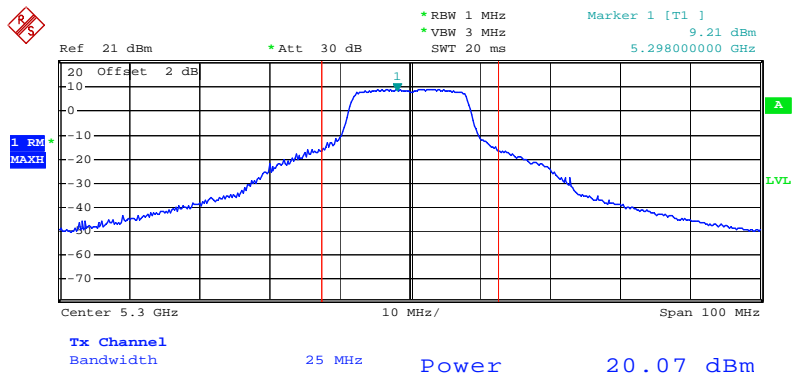

Date: 16.SEP.2009 21:25:32

**Conducted Output Power Plot on Configuration IEEE 802.11a Ant. 5-3 / 5320 MHz**

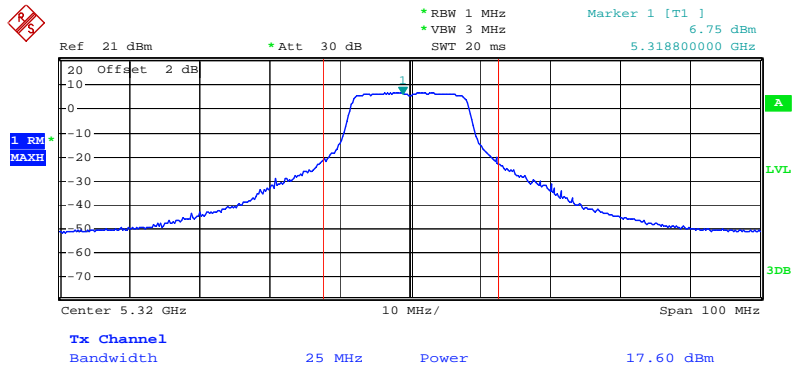

Date: 14.SEP.2009 21:12:59

**Conducted Output Power Plot on Configuration IEEE 802.11a Ant. 5-3 / 5500 MHz**

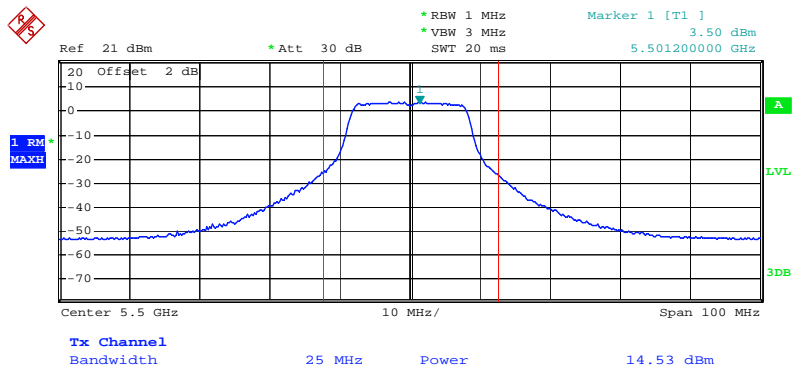

Date: 14.SEP.2009 21:04:59





<For Antenna 6>:

Conducted Output Power Plot on Configuration 802.11n MCS8 20MHz Ant. 6-1 / 5260 MHz

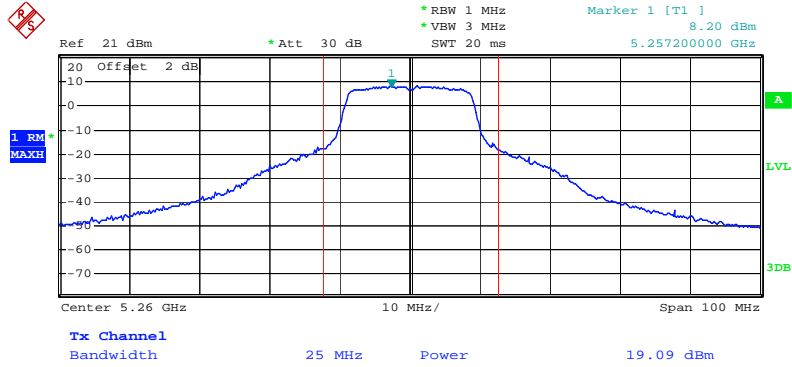

Date: 14.SEP.2009 22:20:07

Conducted Output Power Plot on Configuration 802.11n MCS8 20MHz Ant. 6-1 / 5300 MHz

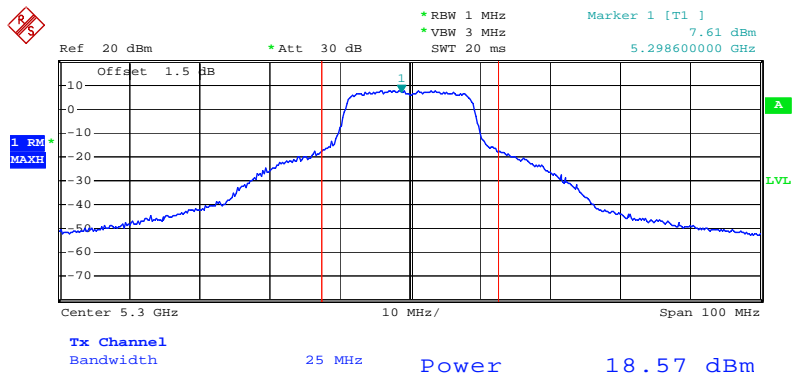

Date: 9.OCT.2009 18:29:30

### Conducted Output Power Plot on Configuration 802.11n MCS8 20MHz Ant. 6-1 / 5320 MHz

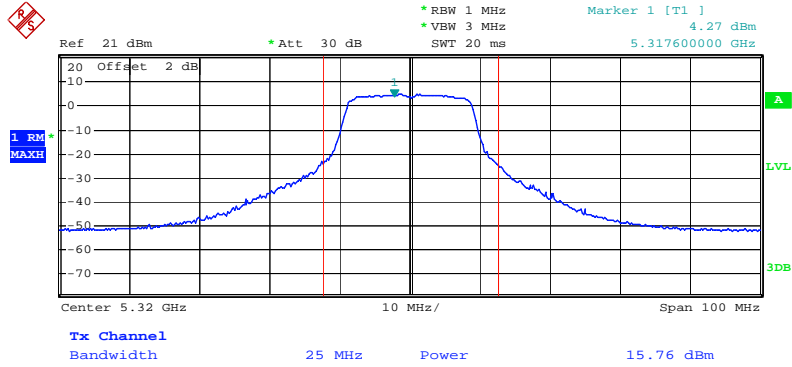

Date: 14.SEP.2009 22:16:56

### Conducted Output Power Plot on Configuration 802.11n MCS8 20MHz Ant. 6-1 / 5500 MHz

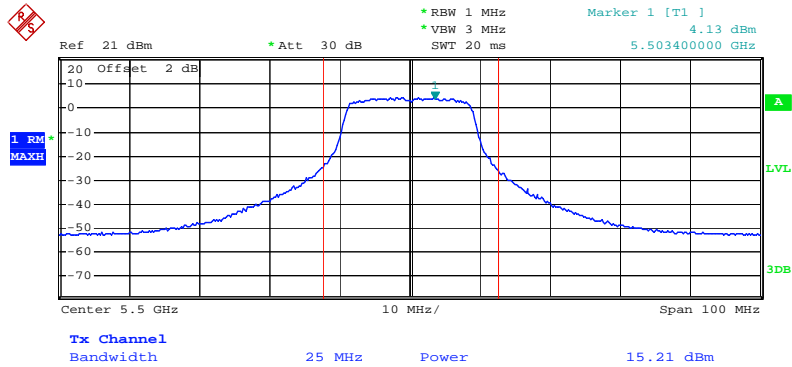

Date: 14.SEP.2009 22:12:55



**Conducted Output Power Plot on Configuration 802.11n MCS8 20MHz Ant. 6-3 / 5260 MHz**

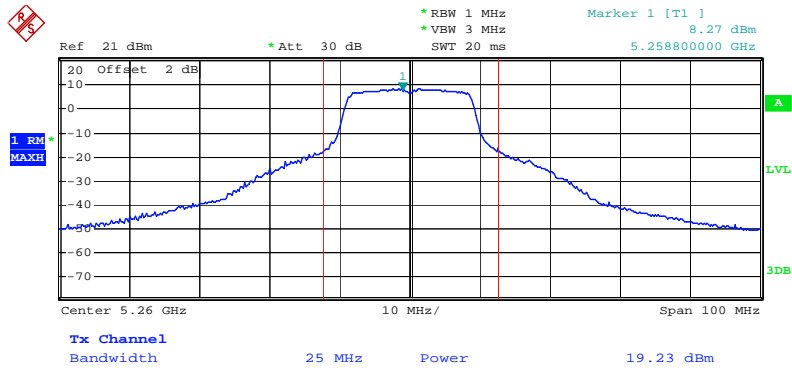

Date: 14.SEP.2009 21:42:56

**Conducted Output Power Plot on Configuration 802.11n MCS8 20MHz Ant. 6-3 / 5300 MHz**

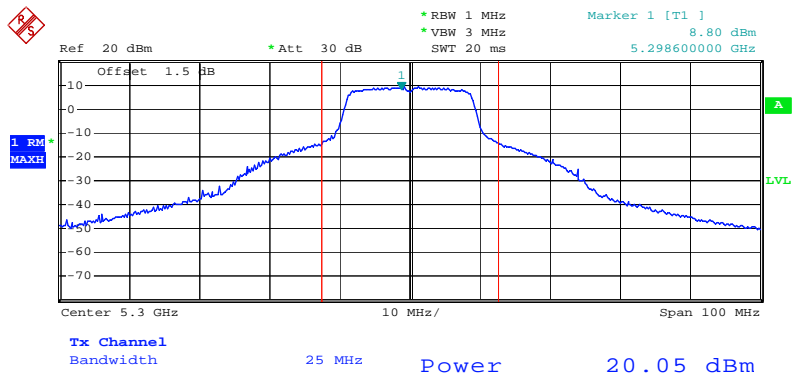

Date: 9.OCT.2009 18:30:21

### Conducted Output Power Plot on Configuration 802.11n MCS8 20MHz Ant. 6-3 / 5320 MHz

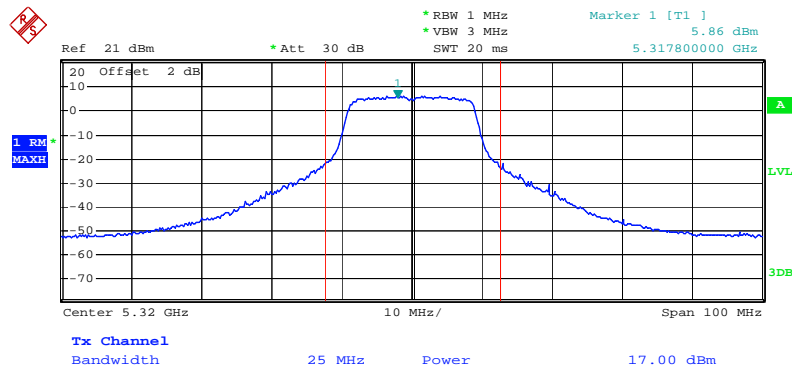

Date: 14.SEP.2009 21:51:55

### Conducted Output Power Plot on Configuration 802.11n MCS8 20MHz Ant. 6-3 / 5500 MHz

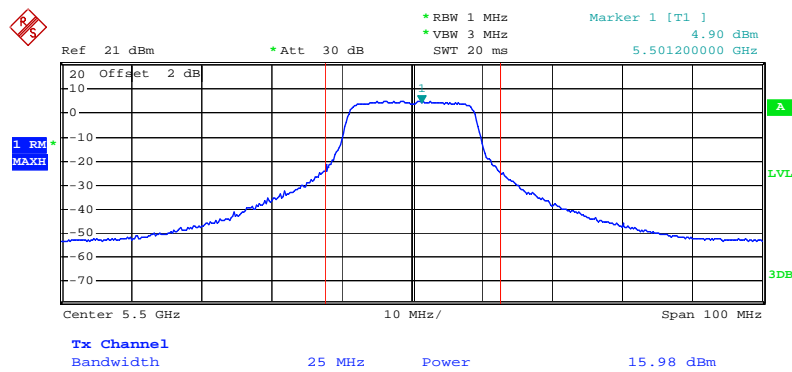

Date: 14.SEP.2009 21:59:06

### Conducted Output Power Plot on Configuration 802.11n MCS8 20MHz Ant. 6-3 / 5580 MHz

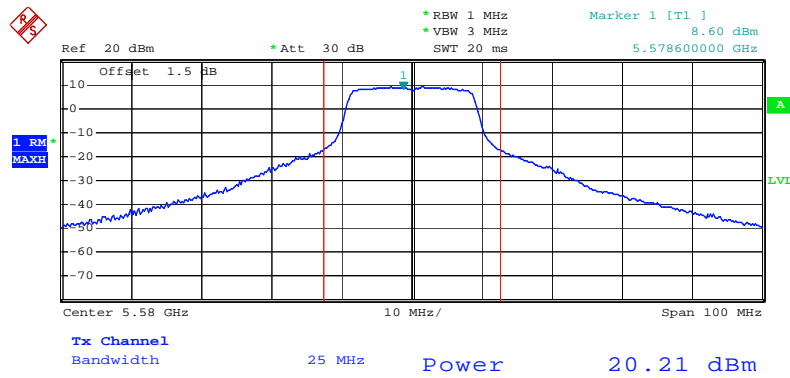

Date: 9.OCT.2009 17:04:58

### Conducted Output Power Plot on Configuration 802.11n MCS8 20MHz Ant. 6-3 / 5700 MHz

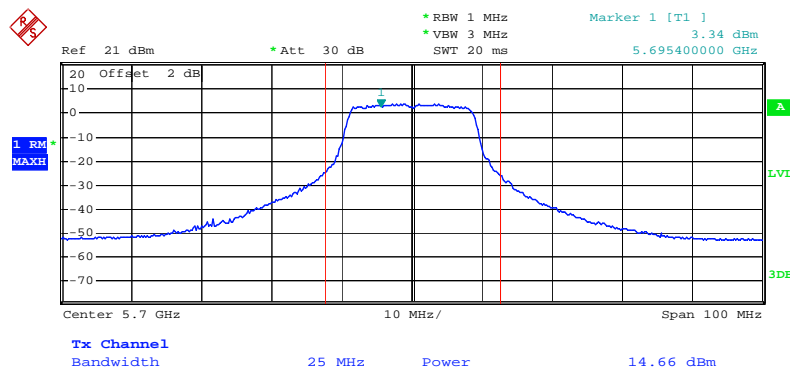

Date: 14.SEP.2009 22:01:03

### Conducted Output Power Plot on Configuration 802.11n MCS8 40MHz Ant. 6-1 / 5270 MHz

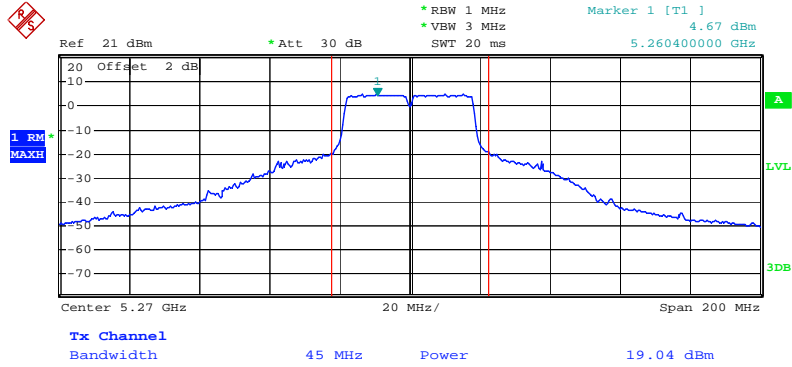

Date: 14.SEP.2009 22:43:45

### Conducted Output Power Plot on Configuration 802.11n MCS8 40MHz Ant. 6-1 / 5310 MHz

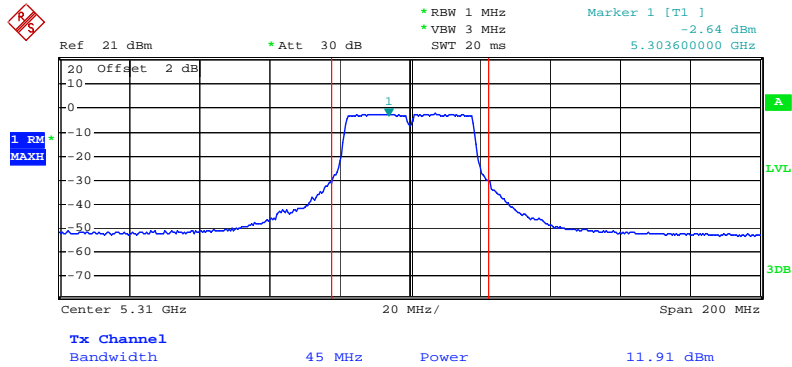

Date: 14.SEP.2009 22:44:49





**Conducted Output Power Plot on Configuration 802.11n MCS8 40MHz Ant. 6-1 / 5670 MHz**

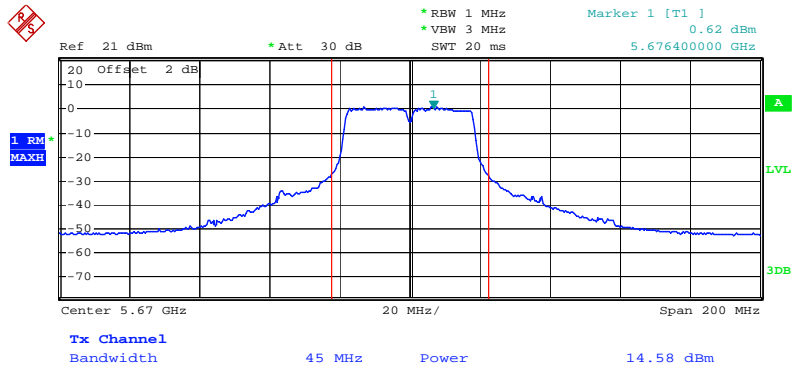

Date: 14.SEP.2009 22:58:32

**Conducted Output Power Plot on Configuration 802.11n MCS8 40MHz Ant. 6-3 / 5270 MHz**

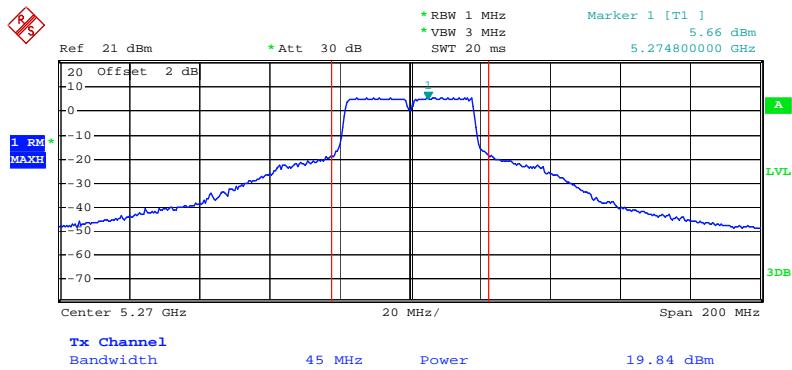

Date: 14.SEP.2009 23:17:43





### Conducted Output Power Plot on Configuration IEEE 802.11a Ant. 6-1 / 5260 MHz

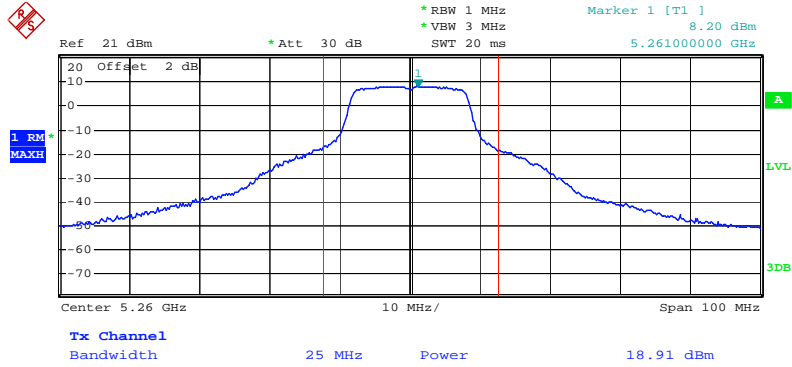

Date: 14.SEP.2009 20:41:55

### Conducted Output Power Plot on Configuration IEEE 802.11a Ant. 6-1 / 5300 MHz

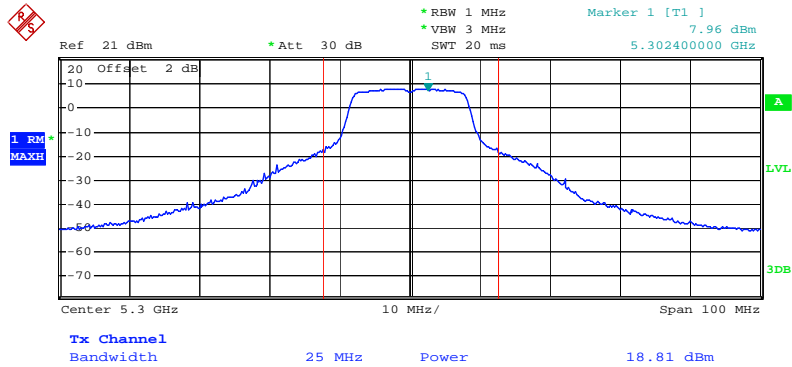

Date: 14.SEP.2009 20:46:09



**Conducted Output Power Plot on Configuration IEEE 802.11a Ant. 6-1 / 5580 MHz**

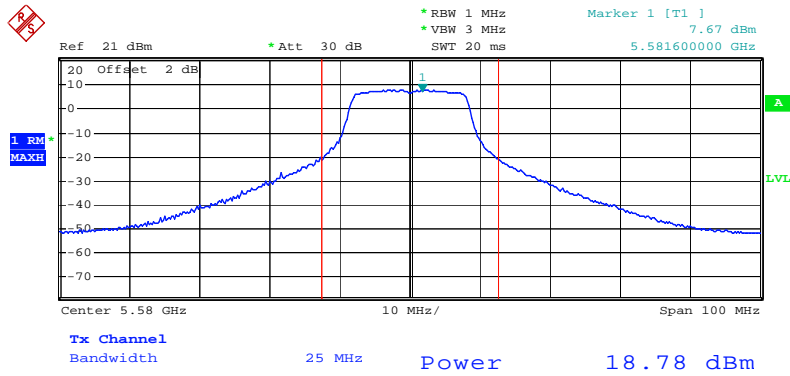

Date: 16.SEP.2009 21:27:49

**Conducted Output Power Plot on Configuration IEEE 802.11a Ant. 6-1 / 5700 MHz**

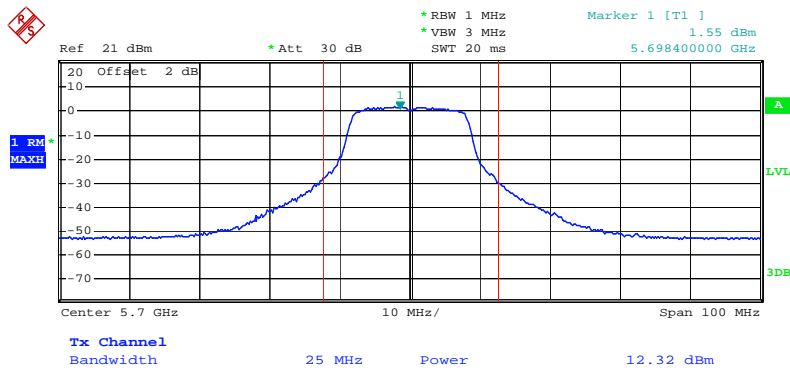

Date: 14.SEP.2009 20:57:55

### Conducted Output Power Plot on Configuration IEEE 802.11a Ant. 6-3 / 5260 MHz

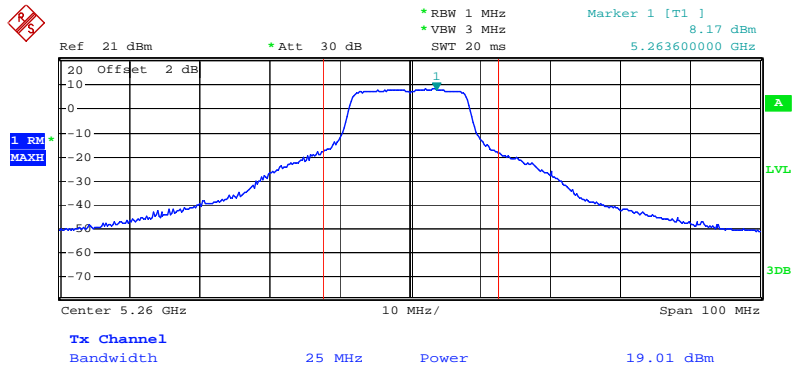

Date: 14.SEP.2009 21:16:59

### Conducted Output Power Plot on Configuration IEEE 802.11a Ant. 6-3 / 5300 MHz

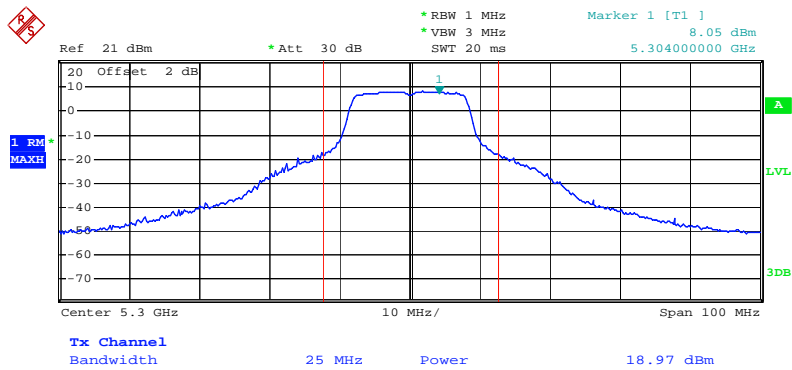

Date: 14.SEP.2009 21:16:13



## Conducted Output Power Plot on Configuration IEEE 802.11a Ant. 6-3 / 5320 MHz

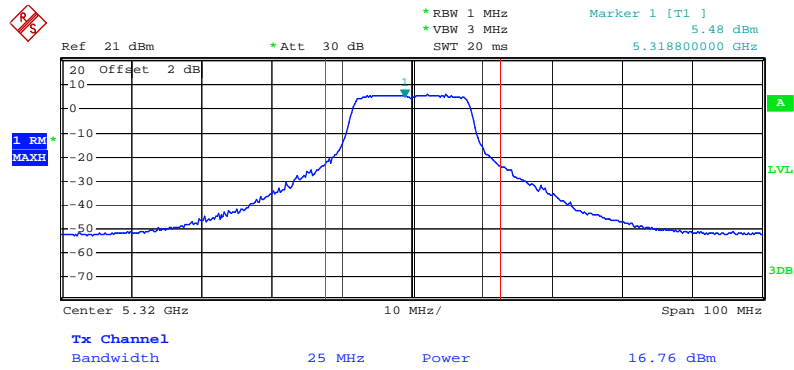

Date: 14.SEP.2009 21:13:33

## Conducted Output Power Plot on Configuration IEEE 802.11a Ant. 6-3 / 5500 MHz

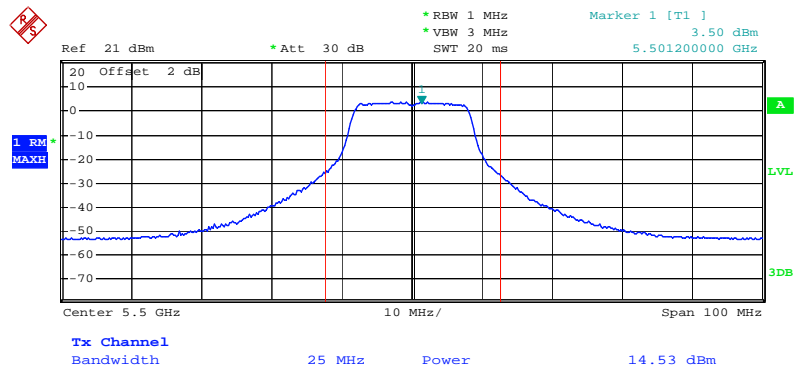

Date: 14.SEP.2009 21:04:59

