



FCC TEST REPORT (PART 90 Subpart R)

REPORT NO.: RF120524C18-6

MODEL NO.: LEX 700

FCC ID: UZ7LEX700

RECEIVED: May 18, 2012

TESTED: May 23 ~ Jun. 18, 2012

ISSUED: Jul. 04, 2012

APPLICANT: Motorola Solutions, Inc.

ADDRESS: One Motorola Plaza, Holtsville, NY 11742-1300
USA

ISSUED BY: Bureau Veritas Consumer Products Services
(H.K.) Ltd., Taoyuan Branch

LAB ADDRESS: No. 47, 14th Ling, Chia Pau Vil., Lin Kou Dist.,
New Taipei City, Taiwan (R.O.C)

TEST LOCATION: No. 19, Hwa Ya 2nd Rd, Wen Hwa Tsuen, Kwei
Shan Hsiang, Taoyuan Hsien 333, Taiwan, R.O.C.

This report should not be used by the client to claim product certification, approval, or endorsement by TAF or any government agencies.



This report is for your exclusive use. Any copying or replication of this report to or for any other person or entity, or use of our name or trademark, is permitted only with our prior written permission. This report sets forth our findings solely with respect to the test samples identified herein. The results set forth in this report are not indicative or representative of the quality or characteristics of the lot from which a test sample was taken or any similar or identical product unless specifically and expressly noted. Our report includes all of the tests requested by you and the results thereof based upon the information that you provided to us. You have 60 days from date of issuance of this report to notify us of any material error or omission caused by our negligence, provided, however, that such notice shall be in writing and shall specifically address the issue you wish to raise. A failure to raise such issue within the prescribed time shall constitute your unqualified acceptance of the completeness of this report, the tests conducted and the correctness of the report contents. Unless specific mention, the uncertainty of measurement has been explicitly taken into account to declare the compliance or non-compliance to the specification.



TABLE OF CONTENTS

RELEASE CONTROL RECORD.....	4
1 CERTIFICATION	5
2 SUMMARY OF TEST RESULTS.....	6
2.1 MEASUREMENT UNCERTAINTY	6
3 GENERAL INFORMATION.....	7
3.1 GENERAL DESCRIPTION OF EUT.....	7
3.2 DESCRIPTION OF TEST MODES.....	9
3.2.1 CONFIGURATION OF SYSTEM UNDER TEST	9
3.2.2 TEST MODE APPLICABILITY AND TESTED CHANNEL DETAIL.....	10
3.3 GENERAL DESCRIPTION OF APPLIED STANDARDS	12
3.4 DESCRIPTION OF SUPPORT UNITS	13
4 TEST TYPES AND RESULTS.....	14
4.1 OUTPUT POWER MEASUREMENT	14
4.1.1 LIMITS OF OUTPUT POWER MEASUREMENT.....	14
4.1.2 TEST INSTRUMENTS	15
4.1.3 TEST PROCEDURES	16
4.1.4 TEST SETUP	17
4.1.5 EUT OPERATING CONDITIONS.....	17
4.1.6 TEST RESULTS	18
4.2 FREQUENCY STABILITY MEASUREMENT	19
4.2.1 LIMITS OF FREQUENCY STABILITY MEASUREMENT.....	19
4.2.2 TEST PROCEDURE	19
4.2.3 TEST SETUP	20
4.2.4 EUT OPERATING CONDITIONS.....	20
4.2.5 TEST RESULTS	21
4.3 OCCUPIED BANDWIDTH MEASUREMENT.....	22
4.3.1 LIMITS OF OCCUPIED BANDWIDTH MEASUREMENT	22
4.3.2 TEST SETUP	22
4.3.3 TEST PROCEDURES	22
4.3.4 EUT OPERATING CONDITIONS.....	22
4.3.5 TEST RESULTS	23
4.4 EMISSION MASK MEASUREMENT	24
4.4.1 LIMITS OF EMISSION MASK MEASUREMENT	24
4.4.2 TEST PROCEDURES	24
4.4.3 TEST SETUP	24
4.4.4 EUT OPERATING CONDITIONS.....	24
4.4.5 TEST RESULTS	25
4.5 BAND EDGE MEASUREMENT	27
4.5.1 LIMITS OF BAND EDGE MEASUREMENT.....	27



A D T

4.5.2	TEST PROCEDURES	27
4.5.3	TEST SETUP	27
4.5.4	EUT OPERATING CONDITION	27
4.5.5	TEST RESULTS	28
4.6	CONDUCTED SPURIOUS EMISSIONS.....	31
4.6.1	LIMITS OF CONDUCTED SPURIOUS EMISSIONS MEASUREMENT	31
4.6.2	TEST PROCEDURE	31
4.6.3	TEST SETUP	31
4.6.4	EUT OPERATING CONDITIONS.....	31
4.6.5	TEST RESULTS	32
4.7	RADIATED EMISSION MEASUREMENT	36
4.7.1	LIMITS OF RADIATED EMISSION MEASUREMENT	36
4.7.2	TEST INSTRUMENTS	36
4.7.3	TEST PROCEDURES.....	37
4.7.4	DEVIATION FROM TEST STANDARD	37
4.7.5	TEST SETUP	38
4.7.6	EUT OPERATING CONDITIONS.....	38
4.7.7	TEST RESULTS	39
5	INFORMATION ON THE TESTING LABORATORIES.....	41
6	APPENDIX A – MODIFICATIONS RECORDERS FOR ENGINEERING CHANGES TO THE EUT BY THE LAB.....	42



A D T

RELEASE CONTROL RECORD

ISSUE NO.	REASON FOR CHANGE	DATE ISSUED
RF120524C18-6	Original release	Jul. 04, 2012



1 CERTIFICATION

PRODUCT : MISSION CRITICAL HANDHELD

MODEL NO. : LEX 700

BRAND : Motorola

APPLICANT : Motorola Solutions, Inc.

TESTED : May 23 ~ Jun. 18, 2012

TEST SAMPLE : ENGINEERING SAMPLE

TEST STANDARDS : FCC Part 90 Subpart R
FCC Part 2

The above equipment (model: LEX 700) has been tested by **Bureau Veritas Consumer Products Services (H.K.) Ltd., Taoyuan Branch**, and found compliance with the requirement of the above standards. The test record, data evaluation & Equipment Under Test (EUT) configurations represented herein are true and accurate accounts of the measurements of the sample's EMC characteristics under the conditions specified in this report.

PREPARED BY :  , **DATE** : Jul. 04, 2012
Pettie Chen / Specialist

APPROVED BY :  , **DATE** : Jul. 04, 2012
Gary Chang / Technical Manager

2 SUMMARY OF TEST RESULTS

The EUT has been tested according to the following specifications:

STANDARD SECTION	TEST TYPE AND LIMIT	RESULT	REMARK
2.1046 90.542(a)(7)	Maximum Peak Output Power Limit: max. 3 watts e.r.p peak power	PASS	Meet the requirement of limit. Maximum ERP is 22.75dBm at 795.5MHz.
2.1055 90.539	Frequency Stability	PASS	Meet the requirement of limit.
2.1049	Occupied Bandwidth	PASS	Meet the requirement of limit.
90.210(n)	Emission Mask	PASS	Meet the requirement of limit.
90.543(e)	Band Edge Measurements	PASS	Meet the requirement of limit.
2.1051 90.543(e)	Conducted Spurious Emissions	PASS	Meet the requirement of limit.
2.1051 90.543(e)(2)	Emission in the 769–775 MHz and 799–805 MHz band	PASS	Meet the requirement of limit.
2.1053 90.543(e)	Radiated Spurious Emissions	PASS	Meet the requirement of limit. Minimum passing margin is -32.5dB at 3191.2MHz.
2.1053 90.543(f)	Emissions in the band 1559–1610 MHz	PASS	Meet the requirement of limit. Minimum passing margin is -19.5dB at 1594.80MHz.

2.1 MEASUREMENT UNCERTAINTY

Where relevant, the following measurement uncertainty levels have been estimated for tests performed on the EUT as specified in CISPR 16-4-2:

MEASUREMENT	FREQUENCY	UNCERTAINTY
Radiated emissions	30MHz ~ 200MHz	2.93 dB
	200MHz ~1000MHz	2.95 dB
	1GHz ~ 18GHz	2.26 dB
	18GHz ~ 40GHz	1.94 dB

This uncertainty represents an expanded uncertainty expressed at approximately the 95% confidence level using a coverage factor of k=2.

3 GENERAL INFORMATION

3.1 GENERAL DESCRIPTION OF EUT

PRODUCT	MISSION CRITICAL HANDHELD
MODEL NO.	LEX 700
POWER SUPPLY	5.0Vdc (adapter or host equipment) 3.7Vdc (Li-ion battery)
MODULATION TECHNOLOGY	LTE Band 14, QPSK, 16QAM
MULTIPLE ACCESS METHOD	FDD
DUPLEX METHOD	FDD
FREQUENCY RANGE	793-798MHz
CHANNEL BANDWIDTH	5MHz
UE CATEGORY	3
MAX. ERP POWER	188.365mW (22.75dBm)
ANTENNA TYPE	Refer to NOTE as below
OPERATION TEMPERATURE RANGE	-30°C ~ 60°C
DATA CABLE	Refer to NOTE as below
I/O PORTS	Refer to user's manual
ACCESSORY DEVICES	Refer to NOTE as below

NOTE:

- The EUT has following accessories.

Battery 1	
P/N	82-154162-01
RATING	3.7V, 1880mAh/7.0Wh

Battery 2	
P/N	82-154162-02
RATING	3.7V, 3760mAh/13.9Wh

*Battery 2 was the worst for final test.

ADAPTER	
BRAND	MOTOROLA
MODEL	IU08-2050120-WP
INPUT	100-240Vac, 50/60Hz, 0.2A
OUTPUT	5Vdc, 1.2A

USB charging cable	
BRAND	MOTOROLA
MODEL	25-128458-01R
CABLE	1.5m shielded cable without core

2. EUT software and firmware version.

OEM NAME	Motorola LEX700
OEM VERSION	0.20.0059
WIRELESS PART NUMBER	31-FUSION-X2.00
WIRELESS FUSION	X_2.00.0.0.041E

3. The following antennas for the EUT.

Item	Type	Gain(dBi)	Connector
Main	Inverted-F	-0.6	NA
Diversity	Inverted-F	-1.0	NA
Monitoring	Inverted-F	-2.5	NA

*Main antenna was the worst for the final test.

4. After pretest of output power and spurious emission under below configurations, **QPSK with 1RB at upper edge** was found to be worst case and was selected for the final test.

MODULATION	RB SETTING
QPSK	1 RB allocated at the upper edge
QPSK	1 RB allocated at the lower edge
QPSK	50% RB allocation centered
QPSK	100% RB allocation
16QAM	1 RB allocated at the upper edge
16QAM	1 RB allocated at the lower edge
16QAM	50% RB allocation centered
16QAM	100% RB allocation

5. The above EUT information is declared by manufacturer and for more detailed feature description, please refer to the manufacturer's specifications or User's Manual.

3.2 DESCRIPTION OF TEST MODES

One channel had been tested.

CHANNEL BANDWIDTH	5MHz
CHANNEL	23355
FREQUENCY (MHz)	795.5

3.2.1 CONFIGURATION OF SYSTEM UNDER TEST

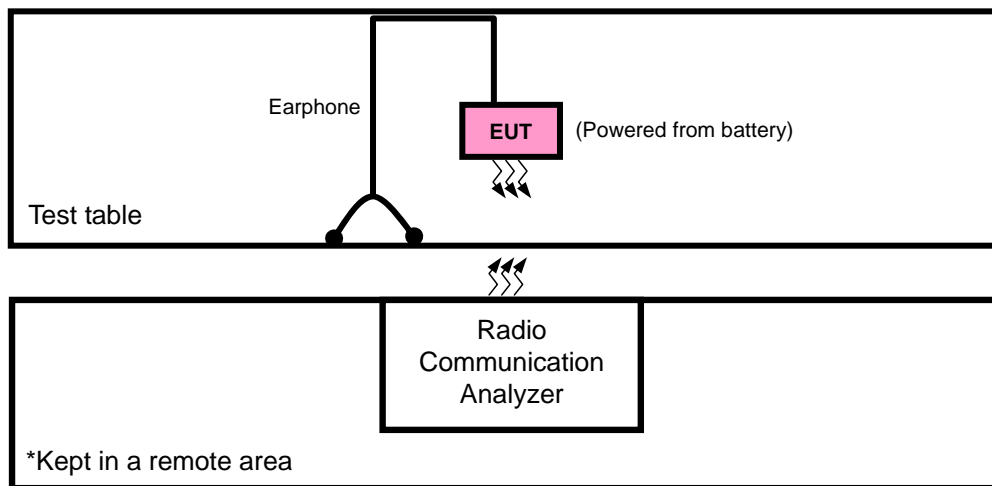

3.2.2 TEST MODE APPLICABILITY AND TESTED CHANNEL DETAIL

EUT CONFIGURE MODE	APPLICABLE TO							DESCRIPTION
	OP	FS	OB	BE	CE	RE<1G	RE≥1G	
-	V	V	V	V	V	V	V	-

Where **OP**: Output power **FS**: Frequency stability
OB: Occupied bandwidth **BE**: Band edge
CE: Conducted spurious emissions **RE<1G**: Radiated emission below 1GHz
RE≥1G: Radiated emission above 1GHz

NOTE:

The EUT had been pre-tested on the positioned of each 3 axis. The worst case was found when positioned on **X-plane**.

OUTPUT POWER MEASUREMENT:

- Pre-Scan has been conducted to determine the worst-case mode from all possible combinations between available modulations and antenna ports (if EUT with antenna diversity architecture).
- Following channel(s) was (were) selected for the final test as listed below.

EUT CONFIGURE MODE	OPERATING BAND	FREQUENCY BAND (MHz)	TESTED FREQUENCY (MHz)	MODULATION TECHNOLOGY
-	LTE	793-798	795.5	QPSK

FREQUENCY STABILITY MEASUREMENT:

- Pre-Scan has been conducted to determine the worst-case mode from all possible combinations between available modulations and antenna ports (if EUT with antenna diversity architecture).
- Following channel(s) was (were) selected for the final test as listed below.

EUT CONFIGURE MODE	OPERATING BAND	FREQUENCY BAND (MHz)	TESTED FREQUENCY (MHz)	MODULATION TECHNOLOGY
-	LTE	793-798	795.5	QPSK

OCCUPIED BANDWIDTH MEASUREMENT:

- This item includes all test value of each mode, but only includes spectrum plot of worst value of each mode.
- Following channel(s) was (were) selected for the final test as listed below.

EUT CONFIGURE MODE	OPERATING BAND	FREQUENCY BAND (MHz)	TESTED FREQUENCY (MHz)	MODULATION TECHNOLOGY
-	LTE	793-798	795.5	QPSK, 16QAM

BAND EDGE MEASUREMENT:

- Pre-Scan has been conducted to determine the worst-case mode from all possible combinations between available modulations and antenna ports (if EUT with antenna diversity architecture).
- Following channel(s) was (were) selected for the final test as listed below.

EUT CONFIGURE MODE	OPERATING BAND	FREQUENCY BAND (MHz)	TESTED FREQUENCY (MHz)	MODULATION TECHNOLOGY
-	LTE	793-798	795.5	QPSK, 16QAM

CONDUCTED SPURIOUS EMISSIONS MEASUREMENT:

- Pre-Scan has been conducted to determine the worst-case mode from all possible combinations between available modulations and antenna ports (if EUT with antenna diversity architecture).
- Following channel(s) was (were) selected for the final test as listed below.

EUT CONFIGURE MODE	OPERATING BAND	FREQUENCY BAND (MHz)	TESTED FREQUENCY (MHz)	MODULATION TECHNOLOGY
-	LTE	793-798	795.5	QPSK, 16QAM

RADIATED EMISSION MEASUREMENT (BELOW 1 GHz):

- Pre-Scan has been conducted to determine the worst-case mode from all possible combinations between available modulations and antenna ports (if EUT with antenna diversity architecture).
- Following channel(s) was (were) selected for the final test as listed below.

EUT CONFIGURE MODE	OPERATING BAND	FREQUENCY BAND (MHz)	TESTED FREQUENCY (MHz)	MODULATION TECHNOLOGY
-	LTE	793-798	795.5	QPSK

RADIATED EMISSION MEASUREMENT (ABOVE 1 GHz):

- Pre-Scan has been conducted to determine the worst-case mode from all possible combinations between available modulations and antenna ports (if EUT with antenna diversity architecture).
- Following channel(s) was (were) selected for the final test as listed below.

EUT CONFIGURE MODE	OPERATING BAND	FREQUENCY BAND (MHz)	TESTED FREQUENCY (MHz)	MODULATION TECHNOLOGY
-	LTE	793-798	795.5	QPSK

TEST CONDITION:

APPLICABLE TO	ENVIRONMENTAL CONDITIONS	INPUT POWER (SYSTEM)	TESTED BY
OP	25deg. C, 68%RH	3.7Vdc	Anderson Hong
FS	25deg. C, 65%RH	3.7Vdc	Mark Liao
OB	25deg. C, 68%RH	3.7Vdc	Anderson Hong
BE	25deg. C, 68%RH	3.7Vdc	Anderson Hong
CE	25deg. C, 68%RH	3.7Vdc	Anderson Hong
RE < 1G	25deg. C, 65%RH	3.7Vdc	Anderson Hong
RE ≥ 1G	25deg. C, 65%RH	3.7Vdc	Anderson Hong

3.3 GENERAL DESCRIPTION OF APPLIED STANDARDS

The EUT is a LTE product. According to the specifications of the manufacturer, it must comply with the requirements of the following standards:

FCC 47 CFR Part 2

FCC 47 CFR Part 90

ANSI/TIA/EIA-603-C 2004

NOTE: All test items have been performed and recorded as per the above standards.

3.4 DESCRIPTION OF SUPPORT UNITS

The EUT has been tested as an independent unit together with other necessary accessories or support units. The following support units or accessories were used to form a representative test configuration during the tests.

NO.	PRODUCT	BRAND	MODEL NO.	SERIAL NO.	FCC ID
1	Earphone	Nokia	NA	NA	NA

NO.	SIGNAL CABLE DESCRIPTION OF THE ABOVE SUPPORT UNITS
1	1.4m shielded cable without core

NOTE: 1. All power cords of the above support units are non shielded (1.8m).
 2. Item 1 was provided by client.

4 TEST TYPES AND RESULTS

4.1 OUTPUT POWER MEASUREMENT

4.1.1 LIMITS OF OUTPUT POWER MEASUREMENT

Per FCC Part 90.542(a)(6)(7),

Control stations and mobile stations transmitting in the 793–798 MHz band are limited to 30 watts ERP.

Portable stations (hand-held devices) transmitting in the 793–798 MHz band are limited to 3 watts ERP.



4.1.2 TEST INSTRUMENTS

DESCRIPTION / MANUFACTURER	MODEL NO.	SERIAL NO.	DATE OF CALIBRATION	DUE DATE OF CALIBRATION
Test Receiver / ROHDE & SCHWARZ	ESCI	100744	Apr. 19, 2012	Apr. 18, 2013
Spectrum Analyzer / ROHDE & SCHWARZ	FSP40	100040	Aug. 04, 2011	Aug. 03, 2012
BILOG Antenna / SCHWARZBECK	VULB9168	9168-156	Apr. 03, 2012	Apr. 02, 2013
HORN Antenna / SCHWARZBECK	BBHA 9120 D	9120D-563	Sep. 06, 2011	Sep. 05, 2012
HORN Antenna / SCHWARZBECK	BBHA 9170	148	Jul. 20, 2011	Jul. 19, 2012
Preamplifier / Agilent	8449B	3008A01911	Oct. 29, 2011	Oct. 28, 2012
Preamplifier / Agilent	8447D	2944A10638	Oct. 29, 2011	Oct. 28, 2012
RF signal cable / HUBER+SUHNER	SUCOFLEX 104	295013/4 283403/4	Aug. 19, 2011	Aug. 18, 2012
RF signal cable / Worken	8D-FB	Cable-HYCH9-01	Aug. 13, 2011	Aug. 12, 2012
Software	ADT_Radiated_V7.6.15.9.2	NA	NA	NA
Antenna Tower / EMCO	2070/2080	512.835.4684	NA	NA
Turn Table / EMCO	2087-2.03	NA	NA	NA
Antenna Tower & Turn Table Controller / EMCO	2090	NA	NA	NA
Radio Communication Analyzer / Anritsu	MT8820C	6201010284	Aug. 01, 2011	Jul. 31, 2012
Spectrum Analyzer / ROHDE & SCHWARZ	E4446A	MY44360128	Feb. 20, 2012	Feb. 19, 2013
Signal Generator / Agilent	E4438C	MY47271120	Sep. 08, 2011	Sep. 07, 2012
RF cable / Suhner	SUCOFLEX 104	257029	Sep. 11, 2011	Sep. 10, 2012
Standard Temperature & Humidity Chamber / WIT	MHU-225AU	911033	Dec. 11, 2011	Dec. 10, 2012
Mini-Circuits Power Splitter	ZAPD-4	NA	Mar. 23, 2012	Mar. 22, 2013
Hewlett Packard RF cable	8120-6192	274388	Oct. 22, 2011	Oct. 21, 2012
JFW 20dB attenuation	50HF-020-SMA	NA	NA	NA
RF cable / Suhner	Sucoflex104	274403/4	Aug. 20, 2011	Aug. 19, 2012
Band Reject Filter / Wainwright Instruments	WRCG 1710/1785-1690/1805-6 0/12SS	SN1	Oct. 28, 2011	Oct. 27, 2012
High Pass Filter / Wainwright Instruments	WHK3.1/18G-10SS	SN3	NA	NA

- NOTE:**
1. The calibration interval of the above test instruments is 12 months and the calibrations are traceable to NML/ROC and NIST/USA.
 2. The test was performed in HwaYa Chamber 9.
 3. The horn antenna and HP preamplifier (model: 8449B) are used only for the measurement of emission frequency above 1GHz if tested.
 4. The FCC Site Registration No. is 460141.
 5. The IC Site Registration No. is IC 7450F-4.

4.1.3 TEST PROCEDURES

ERP MEASUREMENT:

- a. The EUT was set up for the maximum power with LTE link data modulation. The power was measured with Agilent Spectrum Analyzer. All measurements were done at 1 channel. RWB and VBW is 5MHz for LTE
- b. E.I.R.P power measurement. In the semi-anechoic chamber, EUT placed on the 0.8m height of Turn Table, rotated the table around 360 degrees to search the maximum radiation power and receiver antenna shall be rotated vertical and horizontal polarization and moved height from 1m to 4m to find the maximum polar radiated power. The "Read Value" is the spectrum reading the maximum power value.
- c. The substitution horn antenna is substituted for EUT at the same position and signals generator export the CW signal to the substitution antenna via a TX cable. Rotated the Turn Table and moved receiving antenna to find the maximum radiation power. Adjust output power level of S.G to get a Value of spectrum reading equal to "Read Value" of step a. Record the power level of S.G
- d. $EIRP = \text{Output power level of S.G} - \text{TX cable loss} + \text{Antenna gain of substitution horn}$
- e. $E.R.P = E.I.R.P - 2.15 \text{ dB}$

4.1.4 TEST SETUP

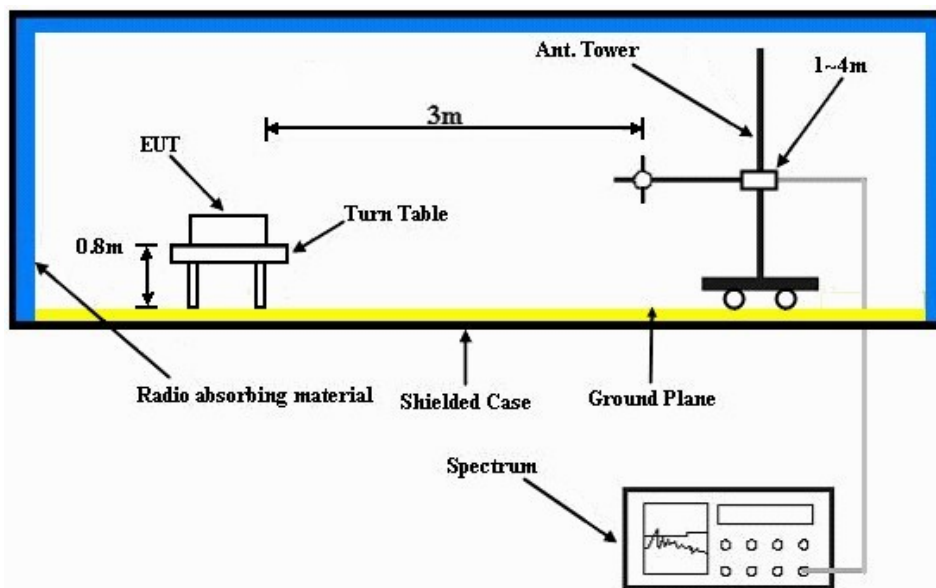

For the actual test configuration, please refer to the attached file (Test Setup Photo).

4.1.5 EUT OPERATING CONDITIONS

- 1) Upload test waveform to signal generator and produce test signal to link up with EUT.
- 2) Execute test tool to control EUT transmit at specific modulation, RB size, frequency and output power level continuously.

Note: Test waveform and tool are provided by client.

4.1.6 TEST RESULTS

CONDUCTED AVERAGE POWER (dBm)

LTE Band 14							
BW	Modulation	CH	Frequency	RB	RB Offset	MPR	Power
			(MHz)				
5 MHz	QPSK	23355	795.5	1	0	0	22.75
		23355	795.5	1	24	0	22.89
		23355	795.5	12	6	1	22.51
		23355	795.5	25	0	1	22.53
	16QAM	23355	795.5	1	0	1	23.07
		23355	795.5	1	24	1	23.30
		23355	795.5	12	6	2	21.42
		23355	795.5	25	0	2	21.45

ERP

CHANNEL BANDWIDTH: 5MHz / QPSK (RB: 1; RB offset: 24)

Channel	Freq. (MHz)	Antenna polarity	Reading (dBm)	S.G Power Value (dBm)	Correction Factor (dB)	ERP (dBm)	Limit (dBm)	Margin (dB)
23305	790.5	H	-6.4	25.4	-0.5	22.75	34.8	-12.05
23305	790.5	V	-14.1	17.1	-0.5	14.45	34.8	-20.35

NOTE: ERP (dBm) = S.G Power Value (dBm) + Correction Factor (dB)-2.15dB.

4.2 FREQUENCY STABILITY MEASUREMENT

4.2.1 LIMITS OF FREQUENCY STABILITY MEASUREMENT

The frequency stability of mobile, portable and control transmitters operating in the wideband segment must be 1.25 parts per million or better when AFC is locked to a base station, and 5 parts per million or better when AFC is not locked.

4.2.2 TEST PROCEDURE

- a. The oven room could control the temperatures and humidity.
- b. Power must be removed when changing from one temperature to another or one voltage to another voltage. Power warm up is at least 15 min and power applied should perform before recording frequency error.
- c. Laptop pc is connected the external power supply to control the DC input power. The various Volts from the minimum to maximum working voltage. Each step shall be record the frequency error rate.
- d. The temperature range step is 10 degrees in this test items. All temperature levels shall be hold the $\pm 0.5^{\circ}\text{C}$ during the measurement testing.
- e. The each temperature step shall be at least 0.5 hours, consider the EUT could be test under the stability condition.

NOTE: The frequency error was recorded frequency error from the communication simulator.

4.2.3 TEST SETUP

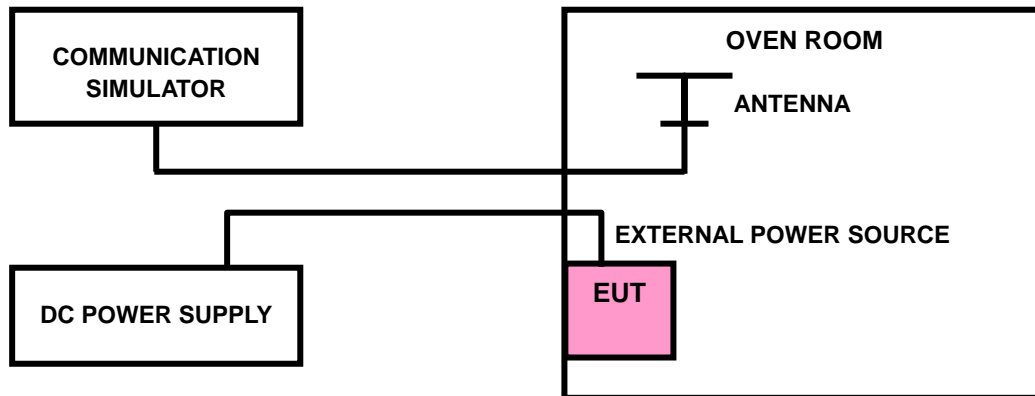

4.2.4 EUT OPERATING CONDITIONS

Same as 4.1.5.

4.2.5 TEST RESULTS

AFC FREQUENCY ERROR vs. VOLTAGE			
VOLTAGE (Volts)	FREQUENCY ERROR (Hz)	FREQUENCY ERROR (ppm)	LIMIT (ppm)
4.255	48	0.060	5
3.28	31	0.039	5

NOTE: The applicant defined the normal working voltage of the battery is from 3.28Vdc to 4.255Vdc.

AFC FREQUENCY ERROR vs. TEMP.			
TEMP. (°C)	FREQUENCY ERROR (Hz)	FREQUENCY ERROR (ppm)	LIMIT (ppm)
60	-82	-0.103	5
50	-75	-0.094	5
40	-44	-0.055	5
30	-35	-0.044	5
20	25	0.031	5
10	31	0.039	5
0	46	0.058	5
-10	58	0.073	5
-20	38	0.048	5
-30	33	0.041	5

4.3 OCCUPIED BANDWIDTH MEASUREMENT

4.3.1 LIMITS OF OCCUPIED BANDWIDTH MEASUREMENT

The width of a frequency band such that, below the lower and above the upper frequency limits, the mean powers emitted are each equal to a specified percentage 0.5 %of the total mean power of a given emission.

4.3.2 TEST SETUP

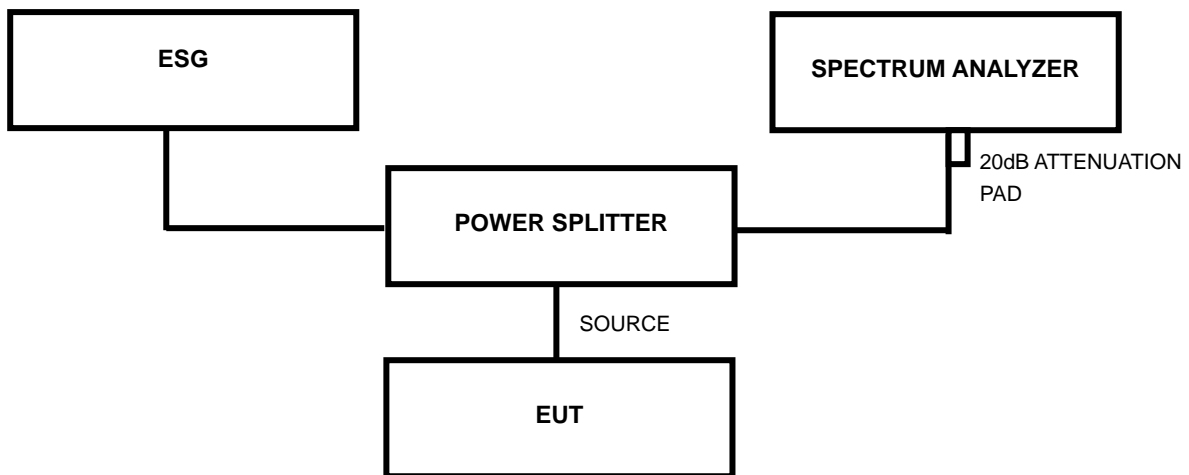

4.3.3 TEST PROCEDURES

- a. The conducted occupied bandwidth used the power splitter via EUT RF power connector between signal generator and spectrum analyzer.
- b. Use OBW measurement function of Spectrum analyzer to measure 99 % occupied bandwidth.

4.3.4 EUT OPERATING CONDITIONS

Same as 4.1.5.



A D T

4.3.5 TEST RESULTS

CHANNEL BANDWIDTH: 5MHz

FREQUENCY (MHz)	MAX. OUTPUT POWER -26 dBc BANDWIDTH (MHz)	
	QPSK	16QAM
795.5	4.4522	4.4740

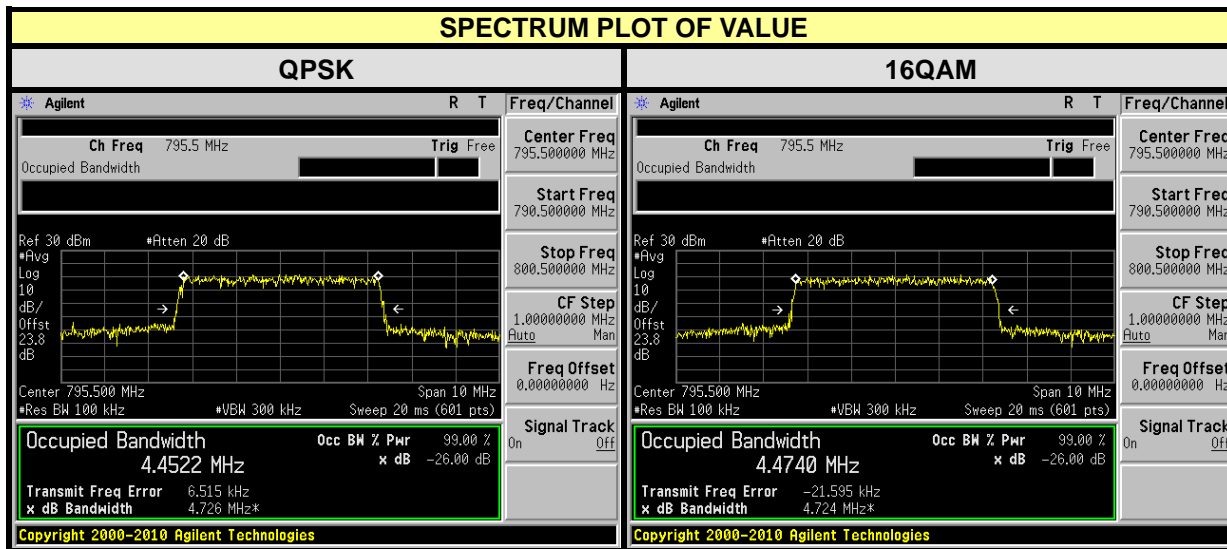

4.4 EMISSION MASK MEASUREMENT

4.4.1 LIMITS OF EMISSION MASK MEASUREMENT

Per 90.210(n), Emission mask shall comply with 90.210(b)

(1) On any frequency removed from the assigned frequency by more than 50 percent, but not more than 100 percent of the authorized bandwidth: At least 25 dB.

(2) On any frequency removed from the assigned frequency by more than 100 percent, but not more than 250 percent of the authorized bandwidth: At least 35 dB.

(3) On any frequency removed from the assigned frequency by more than 250 percent of the authorized bandwidth: At least $43 + 10 \log (P)$ dB

4.4.2 TEST PROCEDURES

1. The power was measured with Agilent Spectrum Analyzer. All measurements were done at 1 channel.
2. The measurement used the power splitter via EUT RF power connector between signal generator and spectrum analyzer.
3. Record the test plot.

4.4.3 TEST SETUP

Same as Item 4.3.3

4.4.4 EUT OPERATING CONDITIONS

Same as 4.1.5.



A D T

4.4.5 TEST RESULTS

QPSK

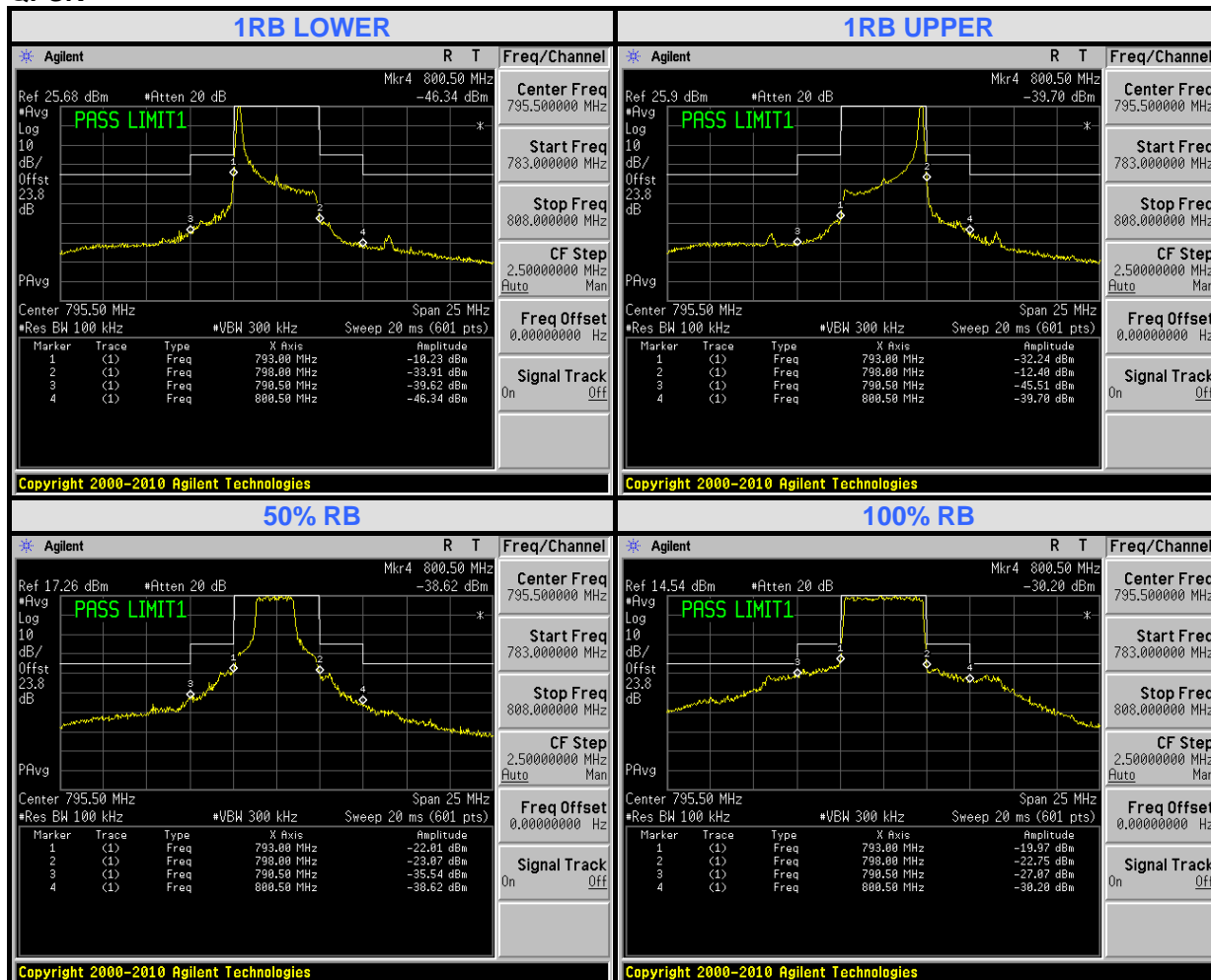



A D T

16QAM

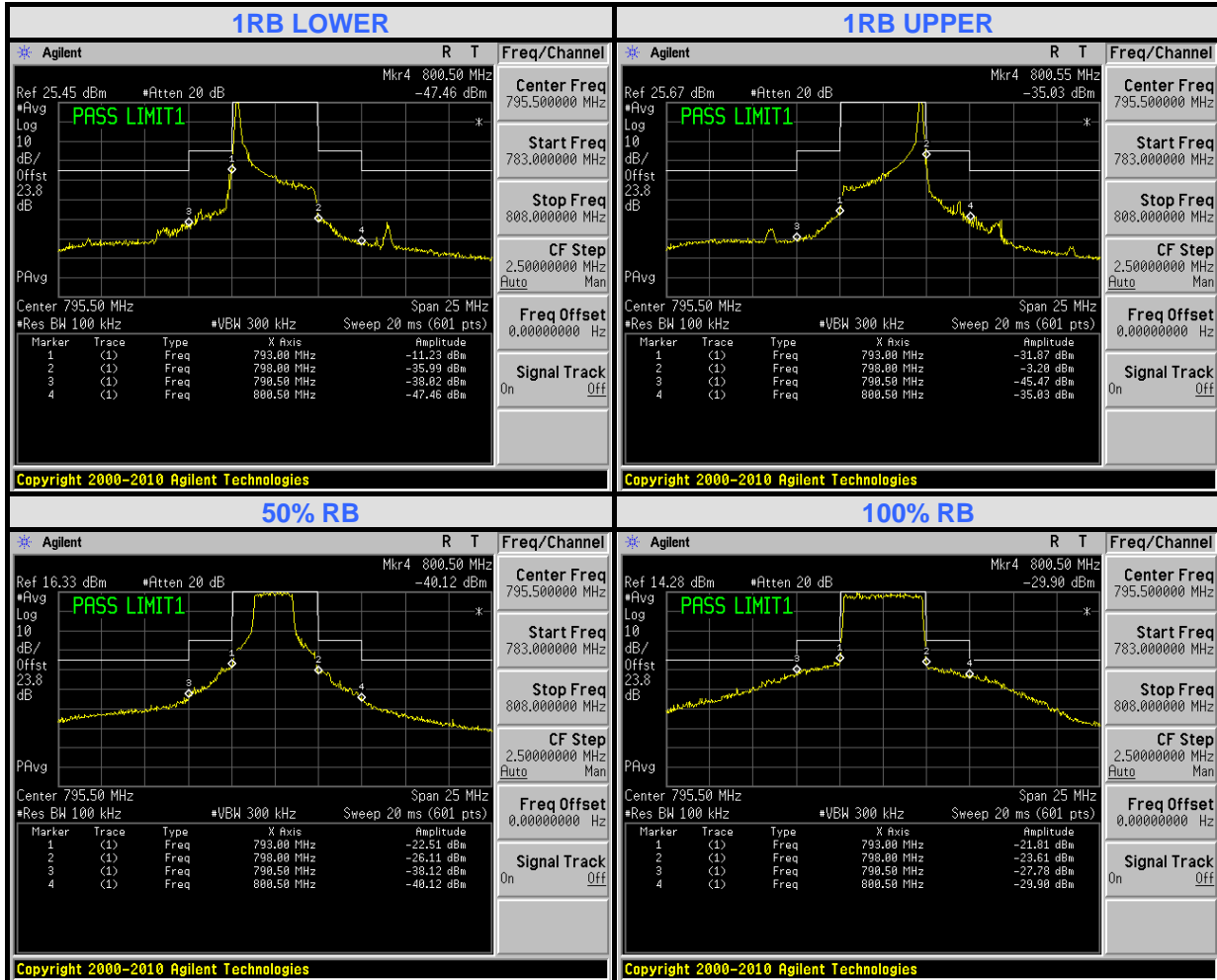

4.5 BAND EDGE MEASUREMENT

4.5.1 LIMITS OF BAND EDGE MEASUREMENT

On any frequency outside of the frequency ranges covered by the ACP tables in this section, the power of any emission must be reduced below the mean output power (P) by at least $43 + 10\log(P)$ dB measured in a 100 kHz bandwidth for frequencies less than 1 GHz, and in a 1MHz bandwidth for frequencies greater than 1 GHz .

4.5.2 TEST PROCEDURES

- a. The EUT was set up for the maximum peak power with LTE link data modulation. The power was measured with Agilent Spectrum Analyzer. All measurements were done at 1 channel
- b. The band edge measurement used the power splitter via EUT RF power connector between signal generator and spectrum analyzer. This splitter loss, attenuator loss and cable loss are the worst loss 21 dB in the transmitted path track.
- c. The center frequency of spectrum is the band edge frequency and span is 1 MHz. RB of the spectrum is 100kHz and VB of the spectrum is 300kHz.
- d. Record the max trace plot into the test report.

4.5.3 TEST SETUP

Same as Item 4.3.3

4.5.4 EUT OPERATING CONDITION

Same as 4.1.5.



A D T

4.5.5 TEST RESULTS

CHANNEL BANDWIDTH: 5MHz

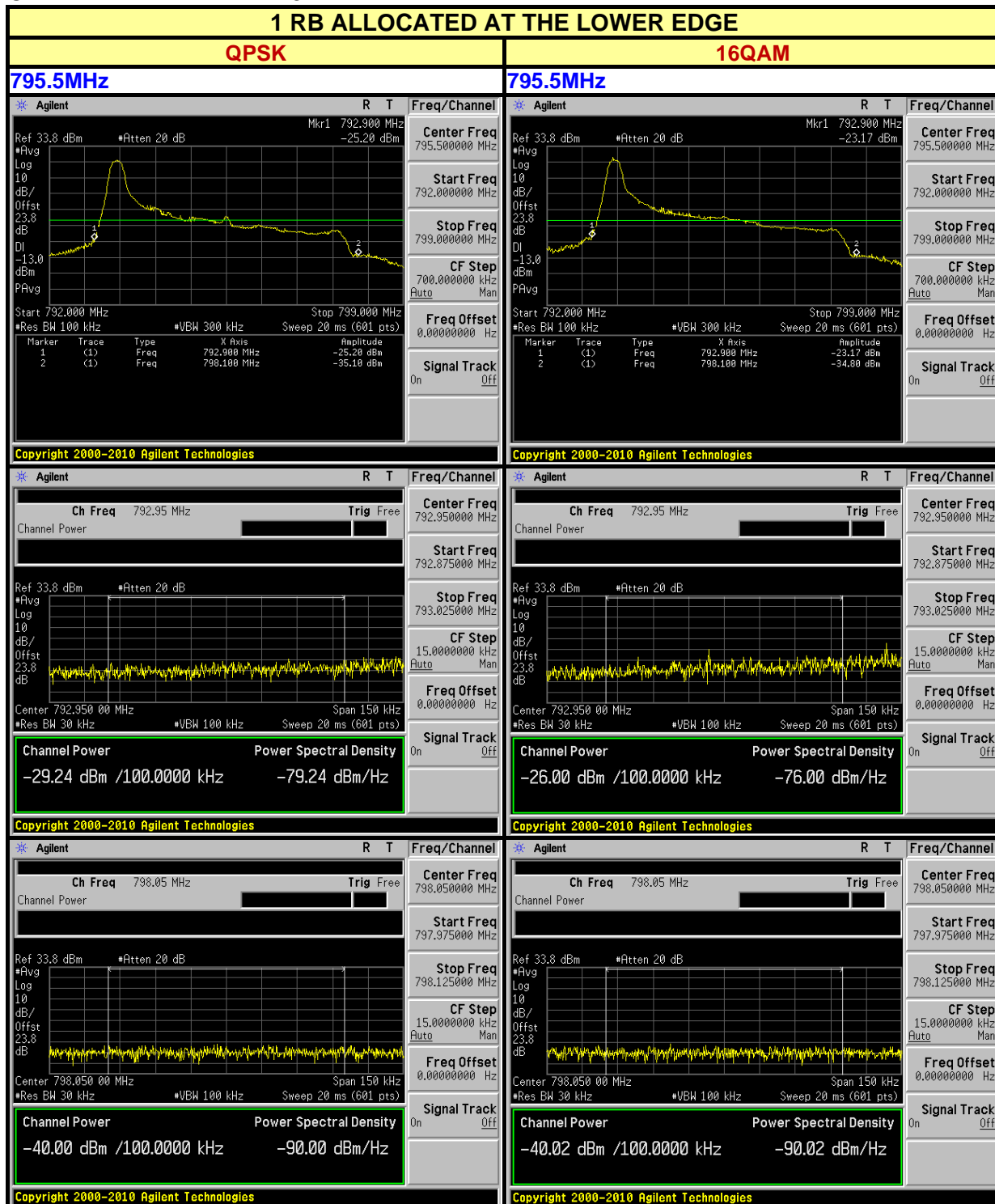



A D T

1 RB ALLOCATED AT THE UPPER EDGE

QPSK 16QAM

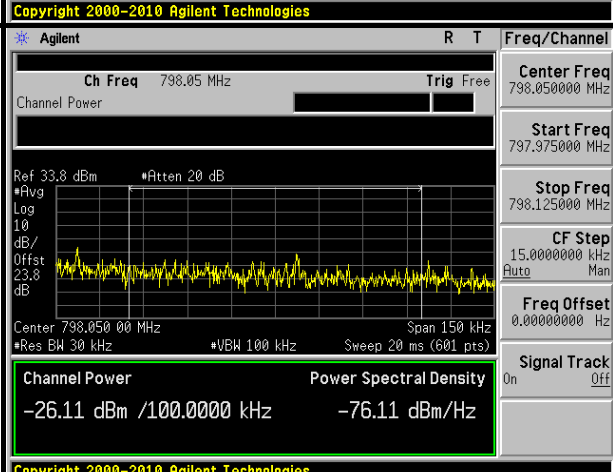
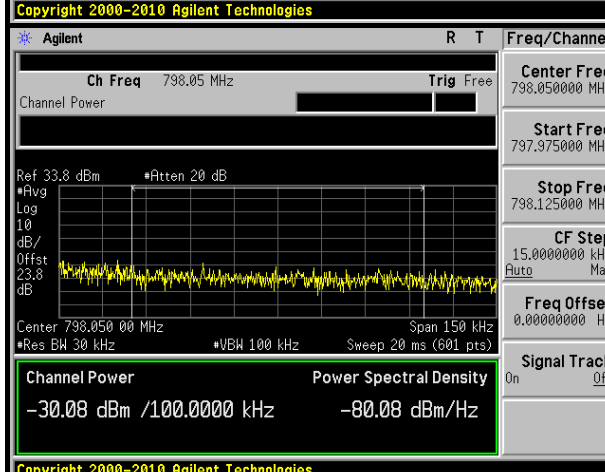
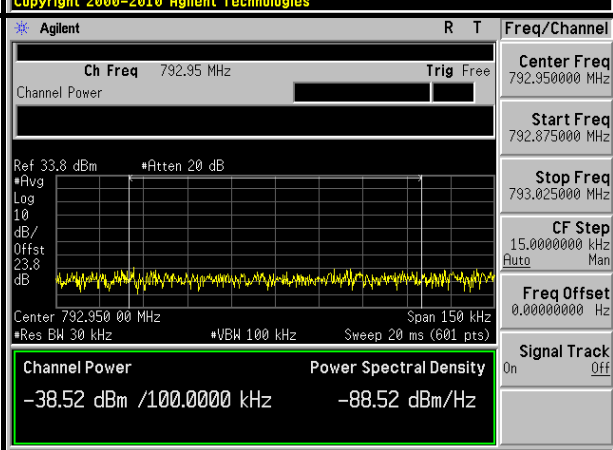
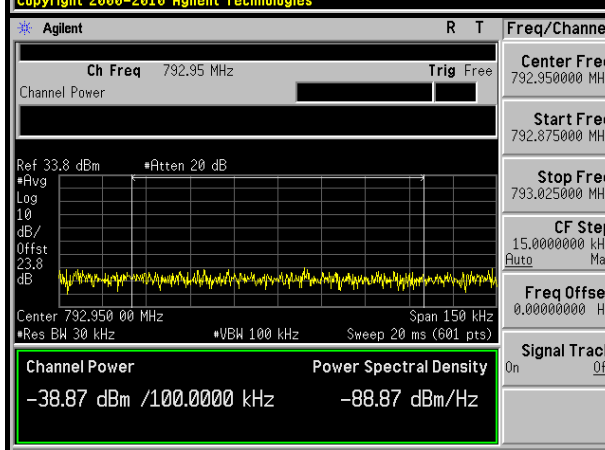
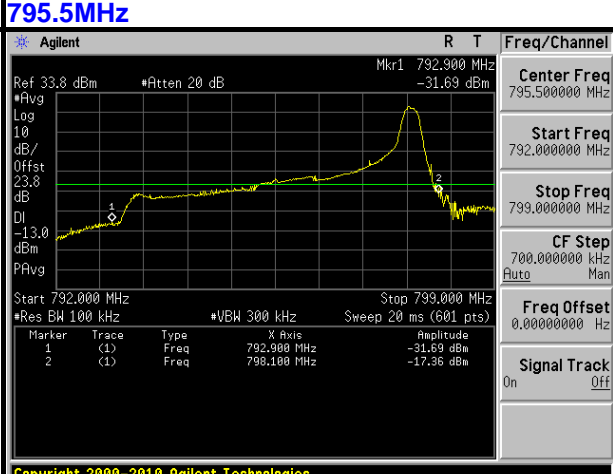
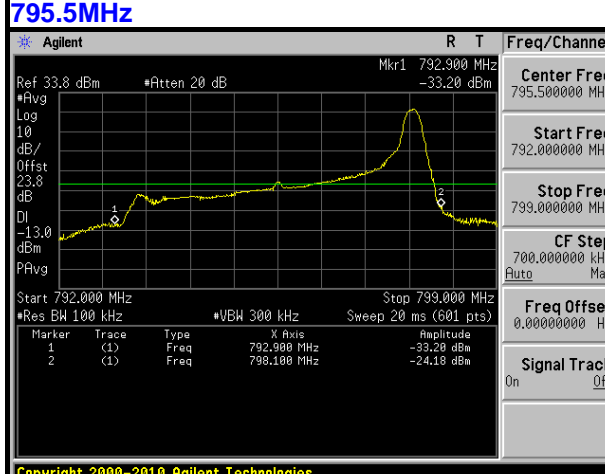



A D T

100% RB ALLOCATION

QPSK 16QAM

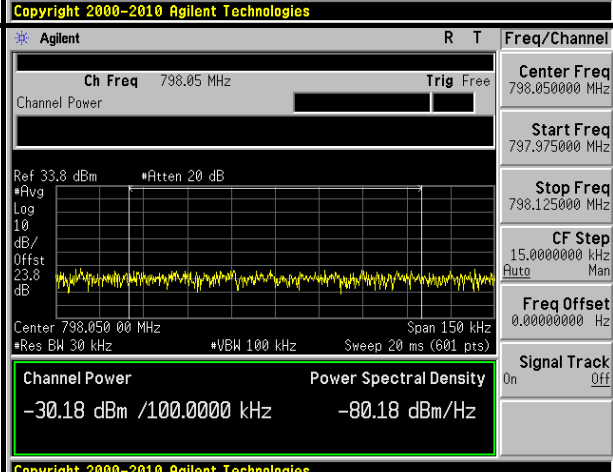
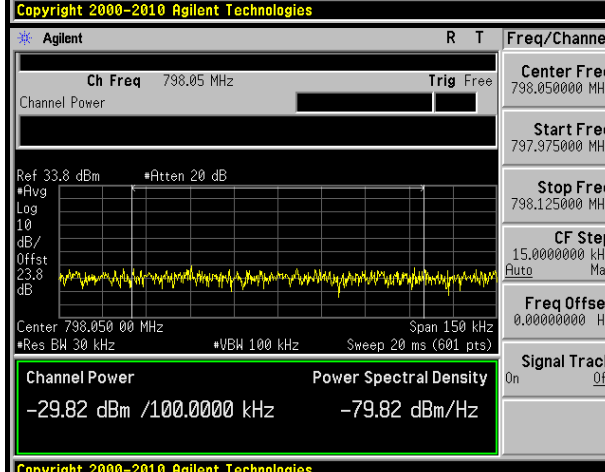
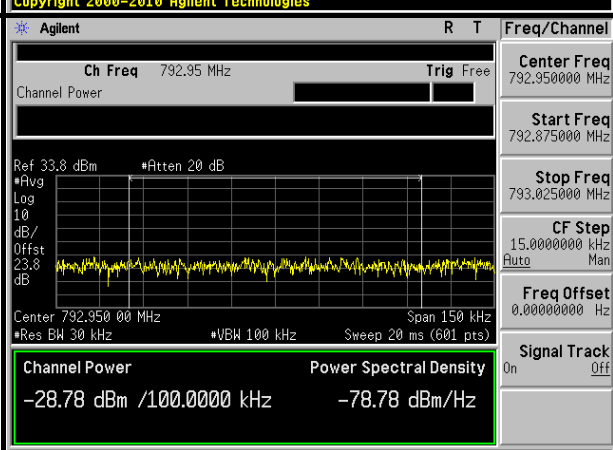
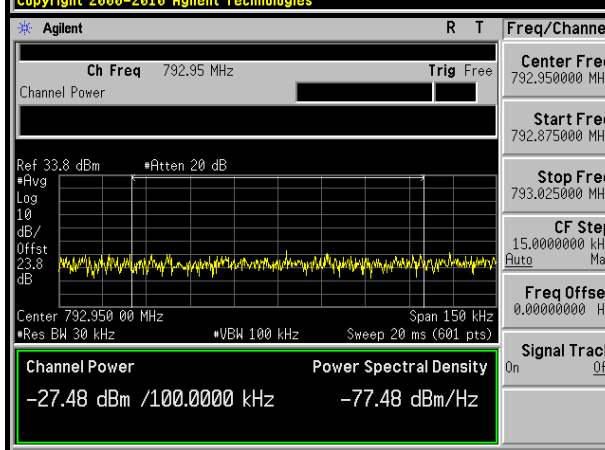
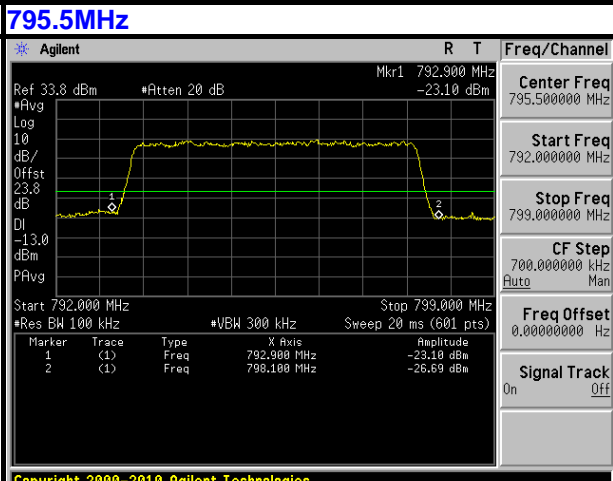
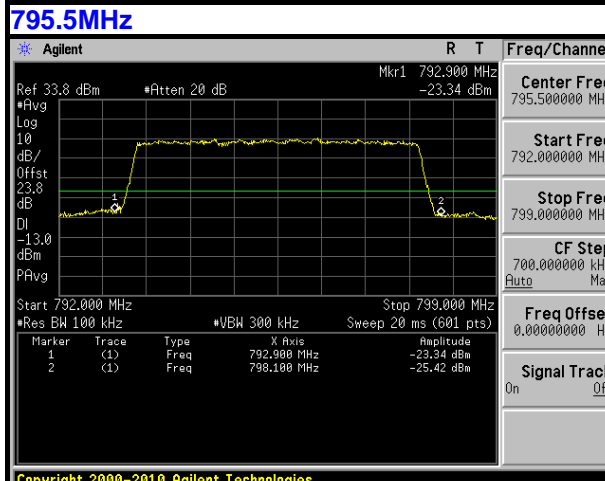

4.6 CONDUCTED SPURIOUS EMISSIONS

4.6.1 LIMITS OF CONDUCTED SPURIOUS EMISSIONS MEASUREMENT

The power of any emission outside a licensee's frequency block shall be attenuated below the transmitter power (P) by at least $43 + 10 \log_{10}(P)$ dB. The limit of emission equal to -13dBm .

On all frequencies between 769 – 775 MHz and 799 – 805 MHz, by a factor not less than $65 + 10 \log(P)$ dB in a 6.25 kHz band segment, for mobile and portable stations.

4.6.2 TEST PROCEDURE

- a. The EUT was set up for the maximum peak power with LTE link data modulation. The power was measured with Agilent Spectrum Analyzer. All measurements were done at 1 channel.
- b. The conducted spurious emission used the power splitter via EUT RF power connector between signal generator and spectrum analyzer.
- c. When the spectrum scanned from 30MHz to 8GHz, it shall be connected to the band reject filter attenuated the carried frequency. The spectrum set $RB=1\text{MHz}$, $VB=3\text{MHz}$.

4.6.3 TEST SETUP

Same as 4.3.3

4.6.4 EUT OPERATING CONDITIONS

Same as 4.1.5.



A D T

4.6.5 TEST RESULTS

CHANNEL BANDWIDTH: 5MHz / QPSK / 1 RB ALLOCATED AT THE UPPER EDGE

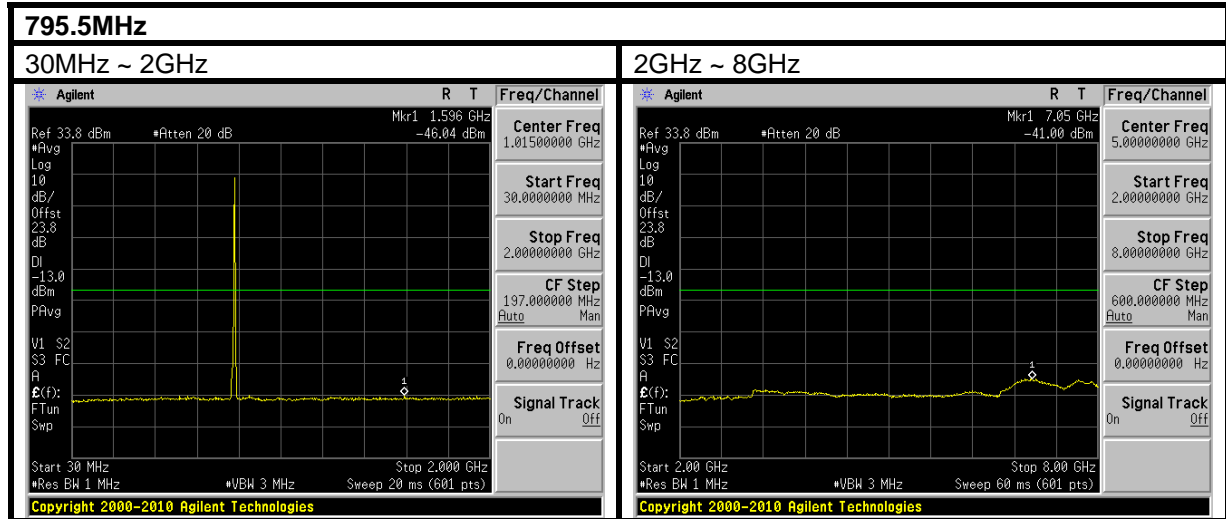

Emission in the 769–775 MHz and 799–805 MHz band

CHANNEL BANDWIDTH: 5MHz / QPSK / 1 RB ALLOCATED AT THE LOWER EDGE

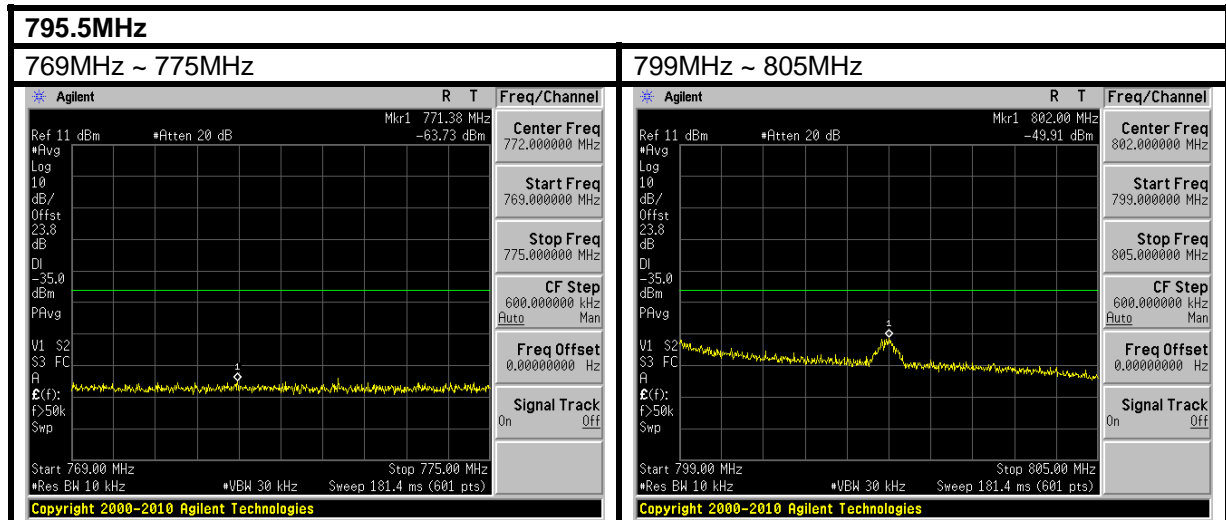



A D T

CHANNEL BANDWIDTH: 5MHz / QPSK / 1 RB ALLOCATED AT THE UPPER EDGE

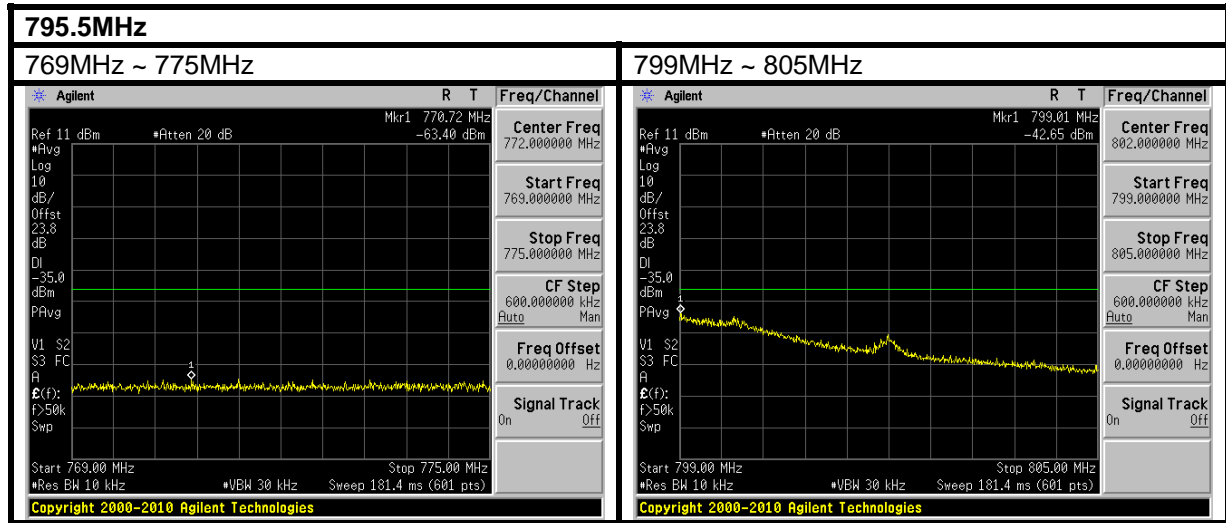

CHANNEL BANDWIDTH: 5MHz / QPSK / 100% RB ALLOCATION

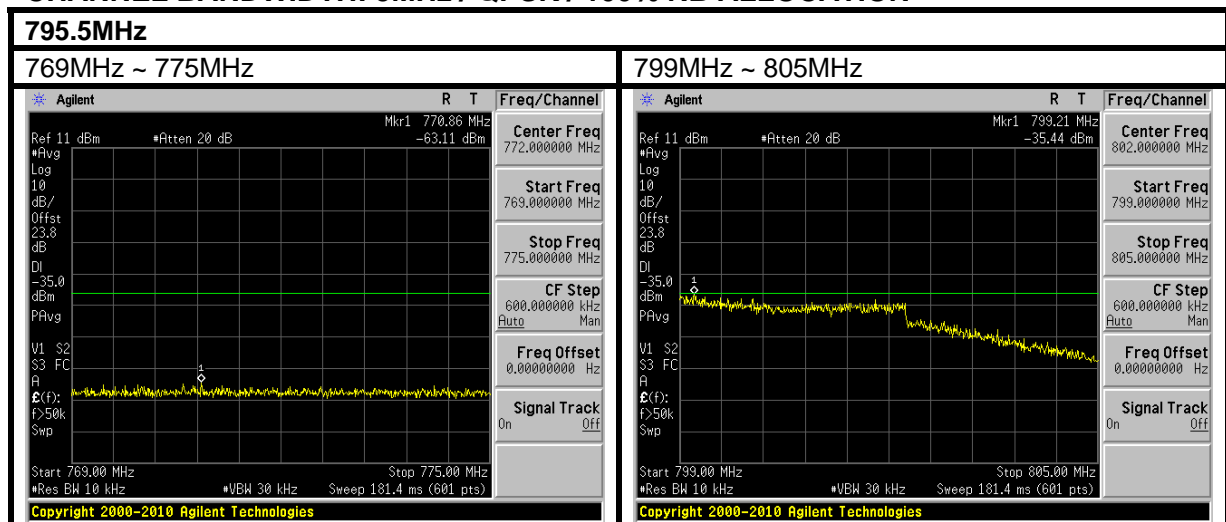



A D T

CHANNEL BANDWIDTH: 5MHz / 16QAM / 1 RB ALLOCATED AT THE UPPER EDGE

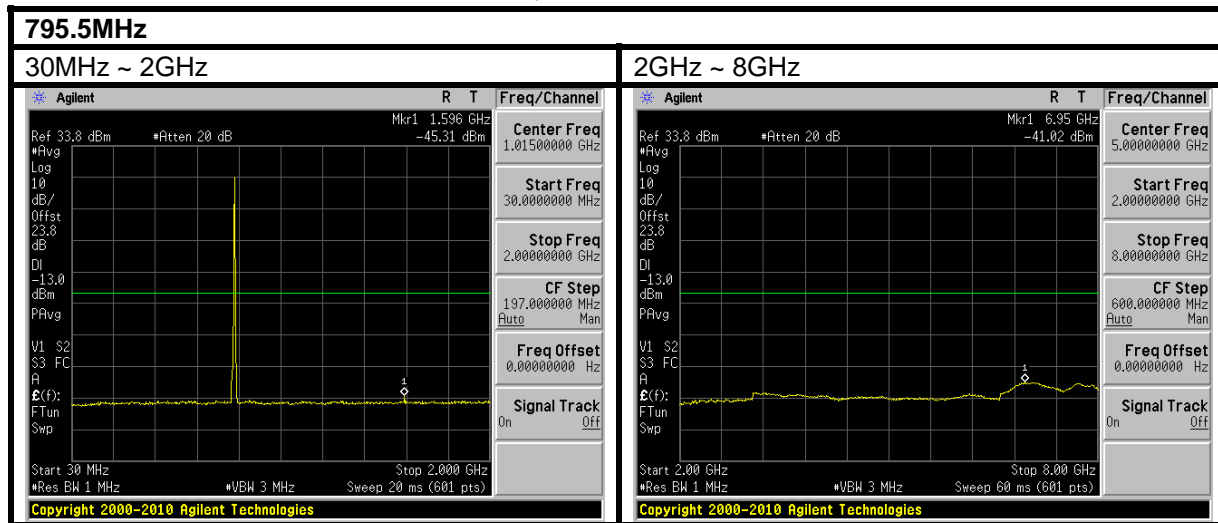

Emission in the 769–775 MHz and 799–805 MHz band

CHANNEL BANDWIDTH: 5MHz / 16QAM / 1 RB ALLOCATED AT THE LOWER EDGE

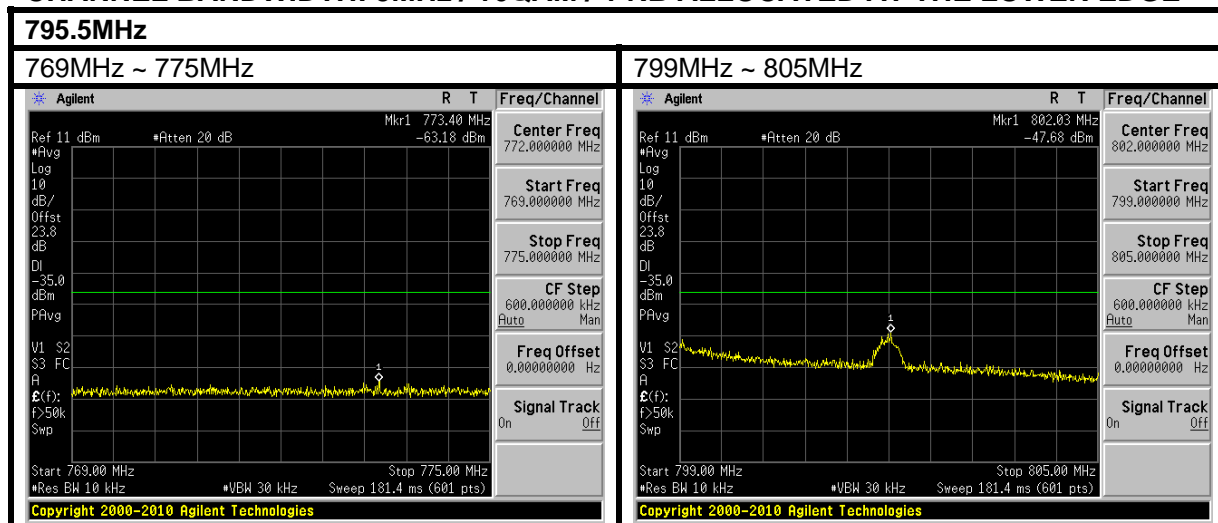



A D T

CHANNEL BANDWIDTH: 5MHz / 16QAM / 1 RB ALLOCATED AT THE UPPER EDGE

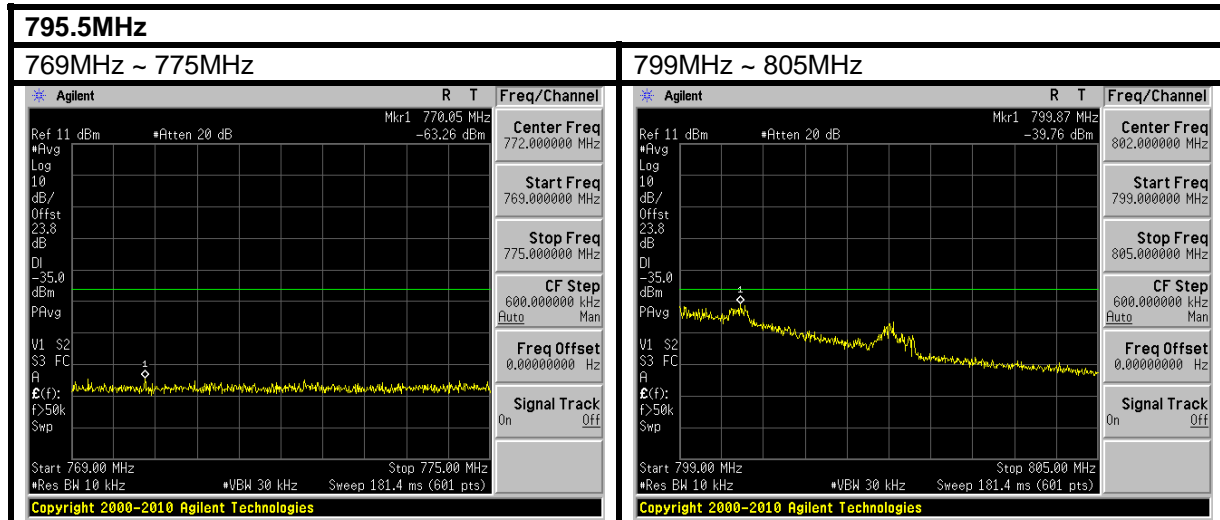

CHANNEL BANDWIDTH: 5MHz / 16QAM / 100% RB ALLOCATION

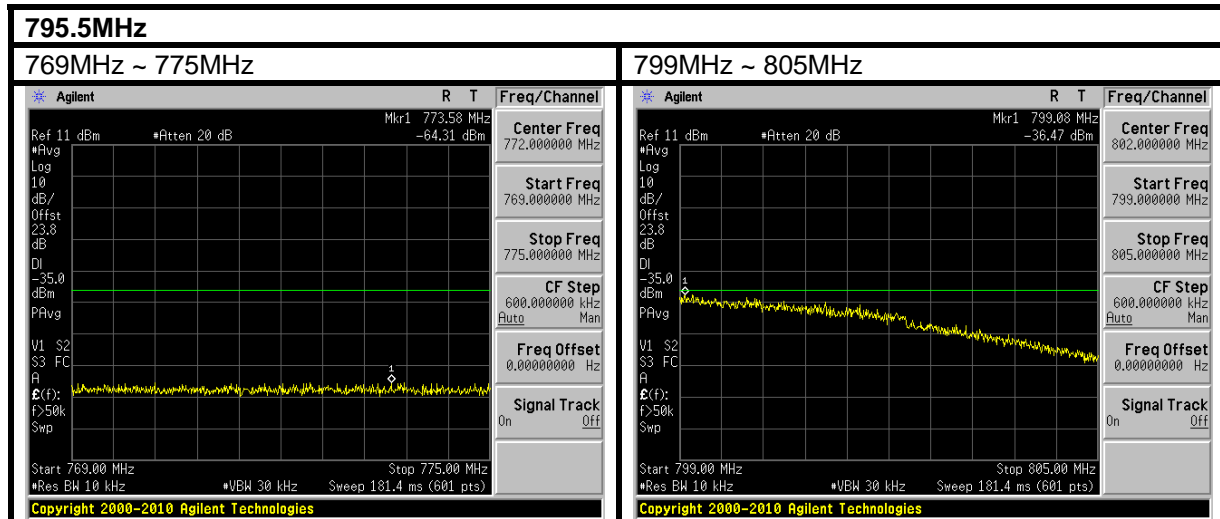

4.7 RADIATED EMISSION MEASUREMENT

4.7.1 LIMITS OF RADIATED EMISSION MEASUREMENT

(1) The power of any emission outside a licensee's frequency block shall be attenuated below the transmitter power (P) by at least $43 + 10 \log_{10}(P)$ dB. The limit of emission equal to -13 dBm

(2) For operations in the 793–805 MHz bands, all emissions including harmonics in the band 1559–1610 MHz shall be limited to -70 dBW/MHz equivalent isotropically radiated power (EIRP) for wideband signals, and -80 dBW EIRP for discrete emissions of less than 700 Hz bandwidth

4.7.2 TEST INSTRUMENTS

Same as 4.1.2.

4.7.3 TEST PROCEDURES

- a. The EUT was placed on the top of a rotating table 0.8 meters above the ground. The table was rotated 360 degrees to determine the position of the highest radiation.
- b. The EUT was set 3 meters away from the receiving antenna, which was mounted on antenna tower and its position at 0.8 m above the ground.
- c. For each suspected emission, the EUT was arranged to its worst case and the rotatable table was turned from 0 degrees to 360 degrees to find the maximum reading and recorded the value.
- d. Repeat step a ~ c for horizontal polarization.

NOTE: The resolution bandwidth of spectrum analyzer is 1 MHz and the video bandwidth is 3 MHz.

4.7.4 DEVIATION FROM TEST STANDARD

No deviation

4.7.5 TEST SETUP

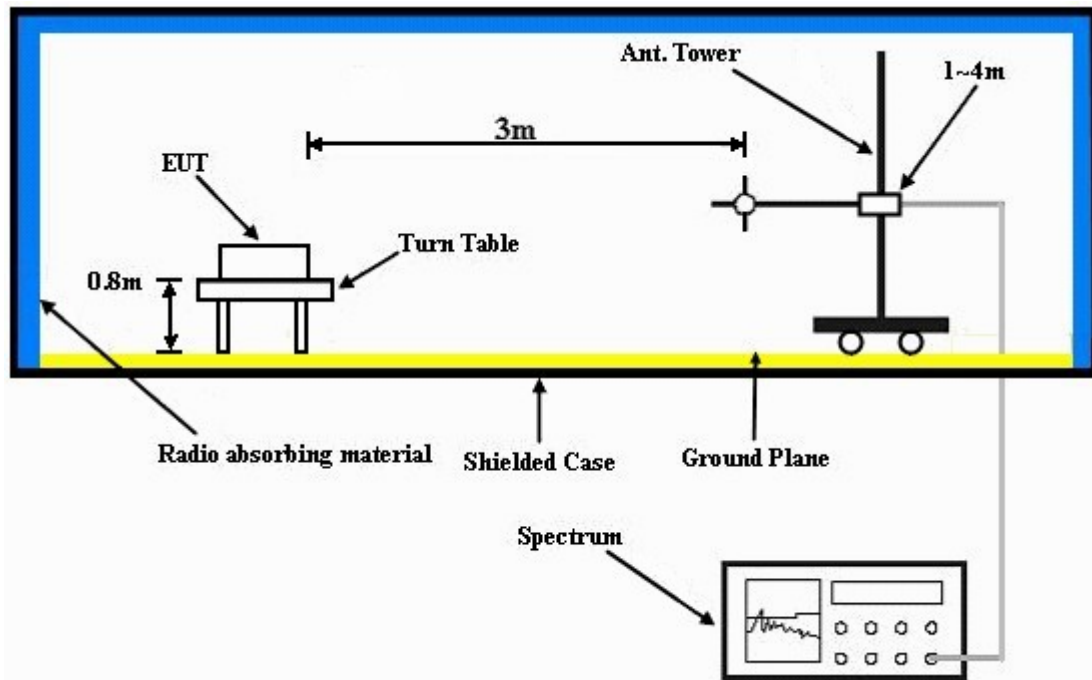

For the actual test configuration, please refer to the attached file (Test Setup Photo).

4.7.6 EUT OPERATING CONDITIONS

Same as 4.1.5.

4.7.7 TEST RESULTS

FOR OUTBAND EMISSION

WORST AT QPSK, 1RB ALLOCATED AT THE UPPER EDGE

BELOW 1GHz DATA:

MODE	795.5MHz	FREQUENCY RANGE	Below 1000MHz
-------------	----------	------------------------	---------------

ANTENNA POLARITY & TEST DISTANCE: HORIZONTAL AT 3 M							
No.	Freq. (MHz)	Reading (dBm)	S.G Power Value (dBm)	Correction Factor (dB)	ERP (dBm)	Limit (dBm)	Margin (dB)
1	66.89	-50.2	-50.0	-5.8	-57.9	-13.0	-44.9
2	112.62	-50.1	-56.6	0.0	-58.8	-13.0	-45.8
3	165.34	-53.0	-58.1	1.1	-59.1	-13.0	-46.1
4	200.38	-50.8	-61.8	5.5	-58.4	-13.0	-45.4
5	267.20	-52.9	-62.7	5.3	-59.5	-13.0	-46.5
6	801.03	-63.2	-61.6	4.0	-59.8	-13.0	-46.8
ANTENNA POLARITY & TEST DISTANCE: VERTICAL AT 3 M							
No.	Freq. (MHz)	Reading (dBm)	S.G Power Value (dBm)	Correction Factor (dB)	ERP (dBm)	Limit (dBm)	Margin (dB)
1	30.59	-47.7	-40.1	-12.5	-54.8	-13.0	-41.8
2	72.12	-45.7	-40.0	-4.3	-46.4	-13.0	-33.4
3	112.19	-53.7	-49.4	0.0	-51.5	-13.0	-38.5
4	202.31	-52.9	-50.8	5.5	-47.4	-13.0	-34.4
5	241.82	-57.5	-55.7	5.4	-52.4	-13.0	-39.4
6	266.03	-55.7	-54.0	5.3	-50.9	-13.0	-37.9

NOTE:

1. Power Value (dBm) = S.G Power Value (dBm) + Correction Factor (dB).
2. The other emission levels were very low against the limit.
3. Margin value = ERP value – Limit value.
4. This is valid for all 3 channels.

ABOVE 1GHz DATA:

ANTENNA POLARITY & TEST DISTANCE: HORIZONTAL AT 3 M							
No.	Freq. (MHz)	Reading (dBm)	S.G Power Value (dBm)	Correction Factor (dB)	ERP (dBm)	Limit (dBm)	Margin (dB)
1	2393.4	-55.6	-57.0	6.4	-52.8	-13.0	-39.8
2	3191.2	-50.6	-50.1	6.7	-45.5	-13.0	-32.5
3	3988.0	-53.7	-50.9	7.0	-46.0	-13.0	-33.0
ANTENNA POLARITY & TEST DISTANCE: VERTICAL AT 3 M							
No.	Freq. (MHz)	Reading (dBm)	S.G Power Value (dBm)	Correction Factor (dB)	ERP (dBm)	Limit (dBm)	Margin (dB)
1	2393.4	-54.9	-54.9	6.4	-50.6	-13.0	-37.6
2	3191.2	-53.4	-53.8	6.7	-49.2	-13.0	-36.2
3	3988.0	-54.0	-52.6	7.0	-47.8	-13.0	-34.8

NOTE: Power Value (dBum) = S.G Power Value (dBm) + Correction Factor (dB).

Emissions in the band 1559–1610 MHz

FOR GPS BAND EMISSION

WORST AT QPSK, 1RB ALLOCATED AT THE UPPER EDGE

ANTENNA POLARITY & TEST DISTANCE: HORIZONTAL AT 3 M							
No.	Freq. (MHz)	Reading (dBm)	S.G Power Value (dBm)	Correction Factor (dB)	EIRP (dBm)	Limit (dBm)	Margin (dB)
1	1594.80	-61.7	-64.9	5.4	-59.5	-40.0	-19.5
ANTENNA POLARITY & TEST DISTANCE: VERTICAL AT 3 M							
No.	Freq. (MHz)	Reading (dBm)	S.G Power Value (dBm)	Correction Factor (dB)	EIRP (dBm)	Limit (dBm)	Margin (dB)
1	1595.60	-62.7	-69.2	5.4	-63.8	-40.0	-23.8

NOTE: Power Value (dBum) = S.G Power Value (dBm) + Correction Factor (dB).



5 INFORMATION ON THE TESTING LABORATORIES

We, Bureau Veritas Consumer Products Services (H.K.) Ltd., Taoyuan Branch, were founded in 1988 to provide our best service in EMC, Radio, Telecom and Safety consultation. Our laboratories are accredited and approved according to ISO/IEC 17025.

If you have any comments, please feel free to contact us at the following:

Linko EMC/RF Lab:

Tel: 886-2-26052180

Fax: 886-2-26051924

Hsin Chu EMC/RF Lab:

Tel: 886-3-5935343

Fax: 886-3-5935342

Hwa Ya EMC/RF/Safety/Telecom Lab:

Tel: 886-3-3183232

Fax: 886-3-3270892

Email: service.adt@tw.bureauveritas.com

Web Site: www.adt.com.tw

The address and road map of all our labs can be found in our web site also.



A D T

6 APPENDIX A – MODIFICATIONS RECORDERS FOR ENGINEERING CHANGES TO THE EUT BY THE LAB

No any modifications are made to the EUT by the lab during the test.

---END---