



SPORTON International Inc.

No. 52, Hwa Ya 1st Rd., Hwa Ya Technology Park, Kwei-Shan Hsiang, Tao Yuan Hsien, Taiwan, R.O.C.
Ph: 886-3-327-3456 / FAX: 886-3-327-0973 / www.sporton.com.tw

FCC RADIO TEST REPORT

Applicant's company	Motorola Solutions, Inc.
Applicant Address	One Motorola Plaza Holtsville, NY 11742 USA
FCC ID	UZ7KHAP800
Manufacturer's company	Wistron NeWeb Corporation
Manufacturer Address	20 Park Avenue II, Hsinchu Science Park, Hsinchu 308, Taiwan, R.O.C.

Product Name	802.11 a/b/g/n Module
Brand Name	MOTOROLA
Model No.	KHAP-800
Test Rule Part(s)	47 CFR FCC Part 15 Subpart C § 15.247
Test Freq. Range	2400 ~ 2483.5MHz / 5725 ~ 5850MHz
Received Date	Apr. 02, 2012
Final Test Date	Sep. 27, 2013
Submission Type	Class II Change

Statement

Test result included is only for the IEEE 802.11n, IEEE 802.11b/g part and IEEE 802.11a (5725 ~ 5850MHz) of the product.

The test result in this report refers exclusively to the presented test model / sample.

Without written approval of SPORTON International Inc., the test report shall not be reproduced except in full.

The measurements and test results shown in this test report were made in accordance with the procedures and found in compliance with the limit given in ANSI C63.10-2009, 47 CFR FCC Part 15 Subpart C, KDB 558074 D01 v03r01 and KDB 662911 D01 v02.

The test equipment used to perform the test is calibrated and traceable to NML/ROC.





Table of Contents

1. CERTIFICATE OF COMPLIANCE	1
2. SUMMARY OF THE TEST RESULT	2
3. GENERAL INFORMATION	3
3.1. Product Details.....	3
3.2. Accessories.....	6
3.3. Table for Filed Antenna.....	7
3.4. Table for Carrier Frequencies	9
3.5. Table for Test Modes	10
3.6. Table for Testing Locations.....	16
3.7. Table for Class II Change	16
3.8. Table for Supporting Units	16
3.9. Table for Parameters of Test Software Setting	17
3.10. EUT Operation during Test	20
3.11. Duty Cycle.....	21
3.12. Test Configurations	34
4. TEST RESULT	35
4.1. Maximum Conducted Output Power Measurement.....	35
4.2. Power Spectral Density Measurement	43
4.3. 6dB Spectrum Bandwidth Measurement	85
4.4. Radiated Emissions Measurement	107
4.5. Emissions Measurement	186
4.6. Antenna Requirements	283
5. LIST OF MEASURING EQUIPMENTS	284
6. TEST LOCATION.....	286
7. MEASUREMENT UNCERTAINTY.....	287
APPENDIX A. TEST PHOTOS	A1 ~ A4
APPENDIX B. MAXIMUM PERMISSIBLE EXPOSURE	B1 ~ B12



History of This Test Report

REPORT NO.	VERSION	DESCRIPTION	ISSUED DATE
FR240223-04AA	Rev. 01	Initial issue of report	Oct. 18, 2013

1. CERTIFICATE OF COMPLIANCE

Product Name : 802.11 a/b/g/n Module
Brand Name : MOTOROLA
Model No. : KHAP-800
Applicant : Motorola Solutions, Inc.
Test Rule Part(s) : 47 CFR FCC Part 15 Subpart C § 15.247

Sporton International as requested by the applicant to evaluate the EMC performance of the product sample received on Apr. 02, 2012 would like to declare that the tested sample has been evaluated and found to be in compliance with the tested rule parts. The data recorded as well as the test configuration specified is true and accurate for showing the sample's EMC nature.

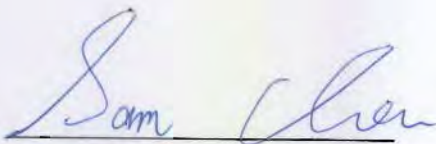

Sam Chen

SPORTON INTERNATIONAL INC.

2. SUMMARY OF THE TEST RESULT

Applied Standard: 47 CFR FCC Part 15 Subpart C				
Part	Rule Section	Description of Test	Result	Under Limit
-	15.207	AC Power Line Conducted Emissions	-	Note 1
4.1	15.247(b)(3)	Maximum Conducted Output Power	Complies	5.89 dB
4.2	15.247(e)	Power Spectral Density	Complies	8.64 dB
4.3	15.247(a)(2)	6dB Spectrum Bandwidth	Complies	-
4.4	15.247(d)	Radiated Emissions	Complies	3.08 dB
4.5	15.247(d)	Band Edge Emissions	Complies	1.03 dB
4.6	15.203	Antenna Requirements	Complies	-

Note 1 : Please refer to section 3.7

3. GENERAL INFORMATION

3.1. Product Details

IEEE 802.11n

Items	Description
Product Type	WLAN (1/2/3TX, 3RX)
Radio Type	Intentional Transceiver
Power Type	powered by PC and DC power supply
Modulation	see the below table for IEEE 802.11n
Data Modulation	OFDM (BPSK / QPSK / 16QAM / 64QAM)
Data Rate (Mbps)	see the below table for IEEE 802.11n
Frequency Range	2400 ~ 2483.5MHz / 5725 ~ 5850MHz
Channel Number	<u>For 2.4GHz Band:</u> 11 for 20MHz bandwidth ; 7 for 40MHz bandwidth <u>For 5GHz Band:</u> 5 for 20MHz bandwidth ; 2 for 40MHz bandwidth
Channel Band Width (99%)	<u>For 2.4GHz Band:</u> For 1TX MCS0 (20MHz): 17.84 MHz ; MCS0 (40MHz): 36.48 MHz For 2TX MCS0 (20MHz): 17.92 MHz ; MCS0 (40MHz): 36.64 MHz MCS8 (20MHz): 17.68 MHz ; MCS8 (40MHz): 36.64 MHz For 3TX MCS0 (20MHz): 17.92 MHz ; MCS0 (40MHz): 36.48 MHz MCS8 (20MHz): 17.76 MHz ; MCS8 (40MHz): 36.32 MHz MCS16 (20MHz): 17.68 MHz ; MCS16 (40MHz): 36.48 MHz <u>For 5GHz Band:</u> For 1TX MCS0 (20MHz): 32.00 MHz ; MCS0 (40MHz): 67.36 MHz For 2TX MCS8 (20MHz): 30.08 MHz ; MCS8 (40MHz): 67.52 MHz For 3TX MCS16 (20MHz): 26.88 MHz ; MCS16 (40MHz): 59.84 MHz

Maximum Conducted Output Power	<p><u>For 2.4GHz Band:</u></p> <p>For 1TX MCS0 (20MHz): 23.38 dBm ; MCS0 (40MHz): 18.94 dBm</p> <p>For 2TX MCS0 (20MHz): 23.94 dBm ; MCS0 (40MHz): 18.47 dBm MCS8 (20MHz): 23.53 dBm ; MCS8 (40MHz): 19.78 dBm</p> <p>For 3TX MCS0 (20MHz): 19.93 dBm ; MCS0 (40MHz): 20.82 dBm MCS8 (20MHz): 20.74 dBm ; MCS8 (40MHz): 20.99 dBm MCS16 (20MHz): 20.35 dBm ; MCS16 (40MHz): 20.34 dBm</p> <p><u>For 5GHz Band:</u></p> <p>For 1TX MCS0 (20MHz): 22.16 dBm ; MCS0 (40MHz): 22.08 dBm</p> <p>For 2TX MCS8 (20MHz): 23.26 dBm ; MCS8 (40MHz): 23.35 dBm</p> <p>For 3TX MCS16 (20MHz): 24.11 dBm ; MCS16 (40MHz): 24.03 dBm</p>
Carrier Frequencies	Please refer to section 3.4
Antenna	Please refer to section 3.3

802.11a/b/g

Items	Description
Product Type	802.11b/g: WLAN (1/2/3TX, 3RX) 802.11a: WLAN (1/2/3TX, 3RX) Note: PIFA Antenna (Model Name: RAI-INT-ANT and KAP-I INT ANT) only 1TX1RX of 11a function
Radio Type	Intentional Transceiver
Power Type	powered by PC and DC power supply
Modulation	DSSS for IEEE 802.11b ; OFDM for IEEE 802.11a/g
Data Modulation	DSSS (BPSK / QPSK / CCK) ; OFDM (BPSK / QPSK / 16QAM / 64QAM)
Data Rate (Mbps)	DSSS (1/ 2/ 5.5/11) ; OFDM (6/9/12/18/24/36/48/54)
Frequency Range	2400 ~ 2483.5MHz / 5725 ~ 5850MHz
Channel Number	11b/g: 11 ; 11a: 5
Channel Band Width (99%)	For 1TX 11b: 13.92 MHz 11g: 16.64 MHz 11a: 30.96 MHz For 2TX 11b: 15.28 MHz 11g: 16.72 MHz For 3TX 11b: 13.04 MHz 11g: 16.56 MHz
Maximum Conducted Output Power	For 1TX 11b: 22.82 dBm 11g: 23.57 dBm 11a: 22.28 dBm For 2TX 11b: 23.99 dBm 11g: 24.08 dBm For 3TX 11b: 21.82 dBm 11g: 20.83 dBm
Carrier Frequencies	Please refer to section 3.4
Antenna	Please refer to section 3.3

Antenna and Band width

Antenna	Single (TX)		Two (TX)		Three (TX)	
	20 MHz	40 MHz	20 MHz	40 MHz	20 MHz	40 MHz
Band width Mode						
IEEE 802.11a	V	X	V	X	V	X
IEEE 802.11b	V	X	V	X	V	X
IEEE 802.11g	V	X	V	X	V	X
IEEE 802.11n	V	V	V	V	V	V

IEEE 11n Spec.

Protocol	Number of Transmit Chains (NTX)	Data Rate / MCS
802.11n (HT20)	1, 2, 3	MCS 0-23
802.11n (HT40)	1, 2, 3	MCS 0-23

Note 1: IEEE Std. 802.11n modulation consists of HT20 and HT40 (HT: High Throughput).
Then EUT support HT20 and HT40.

Note 2: Modulation modes consist of below configuration: HT20/HT40: IEEE 802.11n

3.2. Accessories

N/A

3.3. Table for Filed Antenna

Ant.	Model Name	Antenna Type	Chip/Radio	Antenna Gain		Cable loss		True Gain (dBi)	
				2.4GHz	5GHz	2.4GHz	5GHz	2.4GHz	5GHz
1	ML-2499-FHPA9-01R	Dipole	Radio1/2-CH1/2/3	10.5	-	1.5	-	9	-
2	ML-2499-SD3-01R	Patch	Radio1/2-CH1/2/3	4	-	1	-	3	-
3	ML-2499-BPNA3-01R	Panel	Radio1/2-CH1/2/3	15	-	1	-	14	-
4	ML-2499-BYGA2-01R	Yagi	Radio1/2-CH1/2/3	14.5	-	1	-	13.5	-
5	KAP-FACADE-ANT	Facade	Radio1/2-CH1/2/3	3.5	4	1	1.5	2.5	2.5
6	ML-5299-FHPA10-01R	Dipole	Radio1/2-CH1/2/3	-	10.5	-	2.5	-	8
7	ML-5299-PTA1-01R	Patch	Radio1/2-CH1/2/3	-	3.8	-	1.5	-	2.3
8	ML-2452-PNA7-01R	Panel	Radio1/2-CH1/2/3	8	12	-	1.5	8	10.5
9	ML-5299-BYGA15-012	Yagi	Radio1/2-CH1/2/3	-	10.5	-	2.5	-	8
10	ML-2499-5PNL-72-N	Panel	Radio1/2-CH1/2/3	6.5	-	-	-	6.5	-
11	ML-2499-APA2-01	Dipole	Radio1/2-CH1/2/3	3.2	-	-	-	3.2	-
12	ML-2499-HPA3-01R	Dipole	Radio1/2-CH1/2/3	4	-	-	-	4	-
13	ML-5299-APA1-01R	Dipole	Radio1/2-CH1/2/3	-	4	-	-	-	4
14	ML-5299-HPA1-01R	Dipole	Radio1/2-CH1/2/3	-	6	-	-	-	6
15	ML-2452-APA2-01	Dipole	Radio1/2-CH1/2/3	3	5	-	-	3	5
16	ML-2452-PNA5-01R	Panel	Radio1/2-CH1/2/3	5.5	6	-	-	5.5	6
17	ML-2452-HPA5-036	Dipole	Radio1/2-CH1/2/3	3	5	-	-	3	5
18	ML-2452-APAG2A1-01	Dipole	Radio1/2-CH1/2/3	2.7	2	-	-	2.7	2
19	RAI-INT-ANT	PIFA	Radio1/2-CH1/2/3	4.3	-	-	-	4.3	-
20	ML-2499-HPA4-01	Dipole	Radio1/2-CH1/2/3	4.5	-	1.5	-	3	-
21	ML-2499-HPA8-01	Dipole	Radio1/2-CH1/2/3	8	-	1.5	-	6.5	-
22	ML-5299-HPA5-01	Dipole	Radio1/2-CH1/2/3	-	5.6	-	2.5	-	3.1
23	ML-5299-HPA10-01	Dipole	Radio1/2-CH1/2/3	-	10.5	-	2.5	-	8
24	ML-2452-HPAG5A8-01	Dipole	Radio1/2-CH1/2/3	5	8	1.5	2.5	3.5	5.5
25	ML-2499-HPA3-02R	Dipole	Radio1/2-CH1/2/3	5	-	1	-	4	-
26	ML-2452-HPAG4A6-01	Dipole	Radio1/2-CH1/2/3	4	7.3	1.5	2.5	2.5	4.8
27	ML-2452-HPA6X6-036	Dipole	Radio1/2-CH1/2/3	4	6	1	1.5	3	4.5
28	ML-2452-HPA6M6-072	Dipole	Radio1/2-CH1/2/3	2.8	6.5	1	1.5	1.8	5
29	ML-2452-PNL9M3-036	Panel	Radio1/2-CH1/2/3	11	10.7	1	1.5	10	9.2
30	ML-2452-PTA6M6-036	Panel	Radio1/2-CH1/2/3	5	6	1	1.5	4	4.5
31	KAP-I INT ANT	PIFA	Radio1/2-CH1/2/3	4.4	4.7	-	-	4.4	4.7

Table of TX/RX Function in each antenna:

Item			Module					
			Chain 1		Chain 2		Chain 3	
			TX	RX	TX	RX	TX	RX
Ant.31	2.4GHz	11b	V	V	V	V	V	V
		11g	V	V	V	V	V	V
		11n	V	V	V	V	V	V
	5GHz	11a	V	V	V	V	V	V
		11n	V	V	V	V	V	V

Note : Marked "-" on behalf of no function.

Module	Required 1TX Port
2.4G / 5G	Chain 1

Module	Required 2TX Port
2.4G / 5G	Chain 1 and Chain 2

Module	Required 3TX Port
2.4G / 5G	Chain 1 and Chain 2 and Chain 3

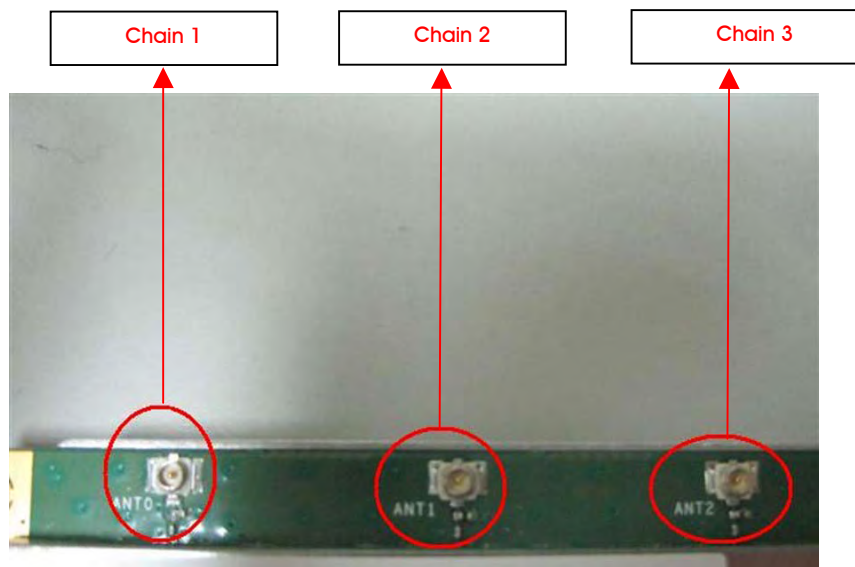

3.4. Table for Carrier Frequencies

For 2.4GHz Band:

There are two bandwidth systems.

For 20MHz bandwidth systems, use Channel 1~Channel 11.

For 40MHz bandwidth systems, use Channel 3~Channel 9.

Frequency Band	Channel No.	Frequency	Channel No.	Frequency
2400~2483.5MHz	1	2412 MHz	7	2442 MHz
	2	2417 MHz	8	2447 MHz
	3	2422 MHz	9	2452 MHz
	4	2427 MHz	10	2457 MHz
	5	2432 MHz	11	2462 MHz
	6	2437 MHz	-	-

For 5GHz Band:

There are two bandwidth systems.

For 20MHz bandwidth systems, use Channel 149, 153, 157, 161, 165.

For 40MHz bandwidth systems, use Channel 151, 159.

Frequency Band	Channel No.	Frequency	Channel No.	Frequency
5725~5850 MHz Band 4	149	5745 MHz	159	5795 MHz
	151	5755 MHz	161	5805 MHz
	153	5765 MHz	165	5825 MHz
	157	5785 MHz	-	-

3.5. Table for Test Modes

Preliminary tests were performed in different data rate to find the worst radiated emission. The data rate shown in the table below is the worst-case rate with respect to the specific test item. Investigation has been done on all the possible configurations for searching the worst cases. The following table is a list of the test modes shown in this test report.

For 2.4GHz Band

Test Items	Mode	Data Rate	Channel	Chain
Maximum Conducted Output Power	11n 20MHz	MCS0	1/6/11	1 1+2 1+2+3
	11n 40MHz	MCS0	3/6/9	1 1+2 1+2+3
	11n 20MHz	MCS8	1/6/11	1 1+2 1+2+3
	11n 40MHz	MCS8	3/6/9	1 1+2 1+2+3
	11n 20MHz	MCS16	1/6/11	1 1+2 1+2+3
	11n 40MHz	MCS16	3/6/9	1 1+2 1+2+3
	11b/CCK	1 Mbps	1/6/11	1 1+2 1+2+3
	11g/BPSK	6 Mbps	1/6/11	1 1+2 1+2+3
Power Spectral Density	11n 20MHz	MCS0	1/6/11	1 1+2 1+2+3
	11n 40MHz	MCS0	3/6/9	1 1+2 1+2+3
	11n 20MHz	MCS8	1/6/11	1 1+2 1+2+3
	11n 40MHz	MCS8	3/6/9	1 1+2 1+2+3
	11n 20MHz	MCS16	1/6/11	1 1+2 1+2+3
	11n 40MHz	MCS16	3/6/9	1 1+2 1+2+3
	11b/CCK	1 Mbps	1/6/11	1 1+2 1+2+3
	11g/BPSK	6 Mbps	1/6/11	1 1+2 1+2+3

6dB Spectrum Bandwidth	11n 20MHz	MCS0	1/6/11	1 1+2 1+2+3
	11n 40MHz	MCS0	3/6/9	1 1+2 1+2+3
	11n 20MHz	MCS8	1/6/11	1 1+2 1+2+3
	11n 40MHz	MCS8	3/6/9	1 1+2 1+2+3
	11n 20MHz	MCS16	1/6/11	1 1+2 1+2+3
	11n 40MHz	MCS16	3/6/9	1 1+2 1+2+3
	11b/CCK	1 Mbps	1/6/11	1 1+2 1+2+3
	11g/BPSK	6 Mbps	1/6/11	1 1+2 1+2+3
Radiated Emissions Below 1GHz	CTX	-	-	-
Radiated Emissions Above 1GHz	11n 20MHz	MCS0	1/6/11	1 1+2 1+2+3
	11n 40MHz	MCS0	3/6/9	1 1+2 1+2+3
	11n 20MHz	MCS8	1/6/11	1 1+2 1+2+3
	11n 40MHz	MCS8	3/6/9	1 1+2 1+2+3
	11n 20MHz	MCS16	1/6/11	1 1+2 1+2+3
	11n 40MHz	MCS16	3/6/9	1 1+2 1+2+3
	11b/CCK	1 Mbps	1/6/11	1 1+2 1+2+3
	11g/BPSK	6 Mbps	1/6/11	1 1+2 1+2+3
Band Edge Emissions	11n 20MHz	MCS0	1/6/11	1 1+2 1+2+3
	11n 40MHz	MCS0	3/6/9	1 1+2 1+2+3
	11n 20MHz	MCS8	1/6/11	1 1+2 1+2+3
	11n 40MHz	MCS8	3/6/9	1 1+2 1+2+3



	11n 20MHz	MCS16	1/6/11	1 1+2 1+2+3
	11n 40MHz	MCS16	3/6/9	1 1+2 1+2+3
	11b/CCK	1 Mbps	1/6/11	1 1+2 1+2+3
	11g/BPSK	6 Mbps	1/6/11	1 1+2 1+2+3

For 5GHz Band

Test Items	Mode	Data Rate	Channel	Chain
Maximum Conducted Output Power	11n 20MHz	MCS0	149/157/165	1
	11n 40MHz	MCS0	151/159	1
	11n 20MHz	MCS8	149/157/165	1+2
	11n 40MHz	MCS8	151/159	1+2
	11n 20MHz	MCS16	149/157/165	1+2+3
	11n 40MHz	MCS16	151/159	1+2+3
	11a/BPSK	6 Mbps	149/157/165	1
Power Spectral Density	11n 20MHz	MCS0	149/157/165	1
	11n 40MHz	MCS0	151/159	1
	11n 20MHz	MCS8	149/157/165	1+2
	11n 40MHz	MCS8	151/159	1+2
	11n 20MHz	MCS16	149/157/165	1+2+3
	11n 40MHz	MCS16	151/159	1+2+3
	11a/BPSK	6 Mbps	149/157/165	1
6dB Spectrum Bandwidth	11n 20MHz	MCS0	149/157/165	1
	11n 40MHz	MCS0	151/159	1
	11n 20MHz	MCS8	149/157/165	1+2
	11n 40MHz	MCS8	151/159	1+2
	11n 20MHz	MCS16	149/157/165	1+2+3
	11n 40MHz	MCS16	151/159	1+2+3
	11a/BPSK	6 Mbps	149/157/165	1
Radiated Emissions Below 1GHz	CTX	-	-	-
Radiated Emissions Above 1GHz	11n 20MHz	MCS0	149/157/165	1
	11n 40MHz	MCS0	151/159	1
	11n 20MHz	MCS8	149/157/165	1+2
	11n 40MHz	MCS8	151/159	1+2
	11n 20MHz	MCS16	149/157/165	1+2+3
	11n 40MHz	MCS16	151/159	1+2+3
	11a/BPSK	6 Mbps	149/157/165	1
Band Edge Emissions	11n 20MHz	MCS0	149/157/165	1
	11n 40MHz	MCS0	151/159	1
	11n 20MHz	MCS8	149/157/165	1+2
	11n 40MHz	MCS8	151/159	1+2
	11n 20MHz	MCS16	149/157/165	1+2+3
	11n 40MHz	MCS16	151/159	1+2+3
	11a/BPSK	6 Mbps	149/157/165	1

The following test modes were performed for all tests:

For Radiated Emissions 30MHz~1GHz test

Mode 1. Module + Antenna 31

The following test modes were performed for Radiated emission above 1GHz tests:

For 2.4GHz Band

Antenna/Radio Mode		11b 1TX	11b 2TX	11b 3TX	11g 1TX	11g 2TX	11g 3TX	H20/40 1TX (MCS0)	H20/40 2TX (MCS0)	H20/40 3TX (MCS0)	H20/40 2TX (MCS8)	H20/40 3TX (MCS8)	H20/40 3TX (MCS16)
Mode 1	PIFA-2.4G, Antenna 31	v	v	v	v	v	v	v	v	v	v	v	v

Note 1: 11g 1TX/2TX/3TX just test output power and band edge. The other test items are covered by 802.11n HT20 1TX/2TX/3TX which are same modulation, bandwidth and frequency.

Note 2: For HT20/40 2TX, MCS0~7(1-stream), MCS8~15(2-stream),; For HT20/40 3TX, MCS16~23(3-stream).

For 5GHz Band

Antenna/Radio Mode		11a 1TX	H20/40 1TX (MCS0)	H20/40 2TX (MCS8)	H20/40 3TX (MCS16)
Mode 2	PIFA-5G, Antenna 31	v	v	v	v

Note 1: For HT20/40 2TX, MCS0~7(1-stream), MCS8~15(2-stream),; For HT20/40 3TX, MCS16~23(3-stream).

Expected Array Gain Adjustment to Antenna Directivity for 2TX / 3TX Configurations and Supported Operational Modes

In the FCC regulatory domain, conducted testing of systems with multiple transmitters (2Tx transmitter configurations) was performed in accordance with KDB 662911 requires adjustment of antenna directivity by an array gain factor. The array gain factor is dependent on correlation of the multiple tx signals, and is therefore a function of operational mode.

The following table establishes the expected array gain for the 2Tx and 3TX transmitter configuration case for each supported operational mode.

Operational Mode > Tx Config ^	11b (DSSS-CCK)	11a/g (Legacy OFDM)	HT20 1 Stream (MCS0-7)	HT40 1 Stream (MCS0-7)	HT20 2 Stream (MCS8-15)	HT40 2 Stream (MCS8-15)	HT20 3 Stream (MCS16-23)	HT40 3 Stream (MCS16-23)
2TX	3.01dB	3.01dB	3.01dB	3.01dB	NA	NA	NA	NA
3TX	4.77dB	4.77dB	4.77dB	4.77dB	3.01dB	3.01dB	NA	NA

For MPE Test

The module (Model number: KHAP-800) is Limited Module Approval and only limited to install to the AP (MOTOROLA / AP-8132), (MOTOROLA / AP-8122), (MOTOROLA / AP-8163), (MOTOROLA / AP-8232), (MOTOROLA / AP-8222) and (MOTOROLA / AP-8263), it verified MPE test.

1. MOTOROLA / AP-8132

The AP (MOTOROLA / AP-8132) could be applied with Radio A (2.4G) RF module (FCC ID: UZ7KHAP800), Radio B (5G) RF module (FCC ID: UZ7KHAP800) and 2.4G/5G USB dongle (FCC ID: UZ7KHUSB600); therefore Maximum Permissible Exposure (Please refer to Appendix B) tests are added for simultaneously transmit between 2.4GHz, 5GHz WLAN function and 2.4G, 5G USB dongle.

2. MOTOROLA / AP-8122

The AP (MOTOROLA / AP-8122) could be applied with Radio A (2.4G) RF module (FCC ID: UZ7KHAP800), and Radio B (5G) RF module (FCC ID: UZ7KHAP800); therefore Maximum Permissible Exposure (Please refer to Appendix B) tests are added for simultaneously transmit between 2.4GHz and 5GHz WLAN function.

3. MOTOROLA / AP-8163

The AP (MOTOROLA / AP-8163) could be applied with Radio A (2.4G) RF module (FCC ID: UZ7KHAP800), Radio B (5G) RF module (FCC ID: UZ7KHAP800) and 2.4G/5G USB dongle (FCC ID: UZ7KHUSB601); therefore Maximum Permissible Exposure (Please refer to Appendix B) tests are added for simultaneously transmit between 2.4GHz, 5GHz WLAN function and 2.4G, 5G USB dongle.

4. MOTOROLA / AP-8232

The AP (MOTOROLA / AP-8232) could be applied with Radio A (2.4G) RF module (FCC ID: UZ7KHAP800), Radio B (5G) RF module (FCC ID: UZ7RAAP800) and 2.4G/5G USB dongle (FCC ID: UZ7KHUSB600); therefore Maximum Permissible Exposure (Please refer to Appendix B) tests are added for simultaneously transmit between 2.4GHz, 5GHz WLAN function and 2.4G, 5G USB dongle.

5. MOTOROLA / AP-8222

The AP (MOTOROLA / AP-8222) could be applied with Radio A (2.4G) RF module (FCC ID: UZ7KHAP800), and Radio B (5G) RF module (FCC ID: UZ7RAAP800); therefore Maximum Permissible Exposure (Please refer to Appendix B) tests are added for simultaneously transmit between 2.4GHz WLAN function and 5GHz WLAN function.

6. MOTOROLA / AP-8263

The AP (MOTOROLA / AP-8263) could be applied with Radio A (2.4G) RF module (FCC ID: UZ7KHAP800), Radio B (5G) RF module (FCC ID: UZ7RAAP800) and 2.4G/5G USB dongle (FCC ID: UZ7KHUSB601); therefore Maximum Permissible Exposure (Please refer to Appendix B) tests are added for simultaneously transmit between 2.4GHz, 5GHz WLAN function and 2.4G, 5G USB dongle.

3.6. Table for Testing Locations

Test Site No.	Site Category	Location	FCC Reg. No.	IC File No.
03CH01-CB	SAC	Hsin Chu	262045	IC 4086D
TH01-CB	OVEN Room	Hsin Chu	-	-

Open Area Test Site (OATS); Semi Anechoic Chamber (SAC) Please refer section 6 for Test Site Address.

3.7. Table for Class II Change

This product is an extension of original one reported under Sporton project number: 240223 and 240223-01

Below is the table for the change of the product with respect to the original one.

Modifications	Performance Checking
1. Adding 9 (Ant.20 ~ Ant.28) set same type of Dipole antenna with lower gain than the original Certificate.	After evaluating, it is not necessary to re-test all test items
2. Adding 2 (Ant.29 ~ Ant.30) set same type of Panel antenna with lower gain than the original Certificate.	After evaluating, it is not necessary to re-test all test items
3. Adding 2 (Ant.19 and Ant.31) PIFA antennas and it only supports 11a 1TX function.	Maximum Conducted Output Power Measurement
	Power Spectral Density Measurement
	6dB Spectrum Bandwidth Measurement
	Radiated Emissions Measurement
	Emissions Measurement
	Note: Because Ant.19 & Ant.31 are the same type antennas, only the higher gain antenna "Ant.31" was tested and written in this report.
Note: There is no hardware or electrical modification made to the applying modular transmitter itself.	

3.8. Table for Supporting Units

Support Unit	Brand	Model	FCC ID
Notebook	DELL	E6430	QDS-BRCM1049LE
Power Supply	Gwinstek	GPC-6030D	N/A

3.9. Table for Parameters of Test Software Setting

During testing, Channel and Power Controlling Software provided by the customer was used to control the operating channel as well as the output power level. The RF output power selection is for the setting of RF output power expected by the customer and is going to be fixed on the firmware of the final end product.

For 2.4GHz Band

Test Mode: Mode 1 (Ant.31 PIFA antenna / 4.4dBi)

Power Parameters of IEEE 802.11n MCS0 / Chain 1

Test Software Version	ART2-GUI 2.3		
Frequency	2412 MHz	2437 MHz	2462 MHz
MCS0 20MHz	15.5	22.5	17.5
Frequency	2422 MHz	2437 MHz	2452 MHz
MCS0 40MHz	12.5	17.5	15

Power Parameters of IEEE 802.11n MCS0 / Chain 1 + Chain 2

Test Software Version	ART2-GUI 2.3		
Frequency	2412 MHz	2437 MHz	2462 MHz
MCS0 20MHz	14	20	15.5
Frequency	2422 MHz	2437 MHz	2452 MHz
MCS0 40MHz	10	14	10.5

Power Parameters of IEEE 802.11n MCS0 / Chain 1 + Chain 2 + Chain 3

Test Software Version	ART2-GUI 2.3		
Frequency	2412 MHz	2437 MHz	2462 MHz
MCS0 20MHz	15	15	14
Frequency	2422 MHz	2437 MHz	2452 MHz
MCS0 40MHz	11.5	15	12

Power Parameters of IEEE 802.11n MCS8 / Chain 1 + Chain 2

Test Software Version	ART2-GUI 2.3		
Frequency	2412 MHz	2437 MHz	2462 MHz
MCS8 20MHz	15	20	15.5
Frequency	2422 MHz	2437 MHz	2452 MHz
MCS8 40MHz	11.5	15.5	12.5

Power Parameters of IEEE 802.11n MCS8 / Chain 1 + Chain 2 + Chain 3

Test Software Version	ART2-GUI 2.3		
Frequency	2412 MHz	2437 MHz	2462 MHz
MCS8 20MHz	16	15	13.5
Frequency	2422 MHz	2437 MHz	2452 MHz
MCS8 40MHz	12	15.5	12.5

Power Parameters of IEEE 802.11n MCS16 / Chain 1 + Chain 2 + Chain 3

Test Software Version	ART2-GUI 2.3		
Frequency	2412 MHz	2437 MHz	2462 MHz
MCS16 20MHz	15.5	13.5	13
Frequency	2422 MHz	2437 MHz	2452 MHz
MCS16 40MHz	11	15	11.5

Power Parameters of IEEE 802.11b/g / Chain 1

Test Software Version	ART2-GUI 2.3		
Frequency	2412 MHz	2437 MHz	2462 MHz
IEEE 802.11b	22.5	22	20
IEEE 802.11g	18.5	23	17.5

Power Parameters of IEEE 802.11b/g / Chain 1 + Chain 2

Test Software Version	ART2-GUI 2.3		
Frequency	2412 MHz	2437 MHz	2462 MHz
IEEE 802.11b	19	20	16.5
IEEE 802.11g	14.5	20	16

Power Parameters of IEEE 802.11b/g / Chain 1 + Chain 2 + Chain 3

Test Software Version	ART2-GUI 2.3		
Frequency	2412 MHz	2437 MHz	2462 MHz
IEEE 802.11b	15	17	16
IEEE 802.11g	16	15	14

For 5GHz Band
Test Mode: Mode 2 (Ant.31 PIFA antenna / 4.7dBi)
Power Parameters of IEEE 802.11n MCS0 / Chain 1

Test Software Version	ART2-GUI 2.3		
Frequency	5745 MHz	5785 MHz	5825 MHz
MCS0 20MHz	25	25	25
Frequency	5755 MHz		5795 MHz
MCS0 40MHz	25		25

Power Parameters of IEEE 802.11n MCS8 / Chain 1 + Chain 2

Test Software Version	ART2-GUI 2.3		
Frequency	5745 MHz	5785 MHz	5825 MHz
MCS8 20MHz	21.5	19	15.5
Frequency	5755 MHz		5795 MHz
MCS8 40MHz	21.5		19

Power Parameters of IEEE 802.11n MCS16 / Chain 1 + Chain 2 + Chain 3

Test Software Version	ART2-GUI 2.3		
Frequency	5745 MHz	5785 MHz	5825 MHz
MCS16 20MHz	21.5	18	16
Frequency	5755 MHz		5795 MHz
MCS16 40MHz	21.5		19

Power Parameters of IEEE 802.11a / Chain 1

Test Software Version	ART2-GUI 2.3		
Frequency	5745 MHz	5785 MHz	5825 MHz
IEEE 802.11a	25	25	25

3.10. EUT Operation during Test

The EUT was programmed to be in continuously transmitting mode.

3.11. Duty Cycle

For 2.4GHz Band:

Test Mode: Mode 1 (Ant.31 PIFA antenna / 4.4dBi)

IEEE 802.11n MCS0 20MHz / Chain 1

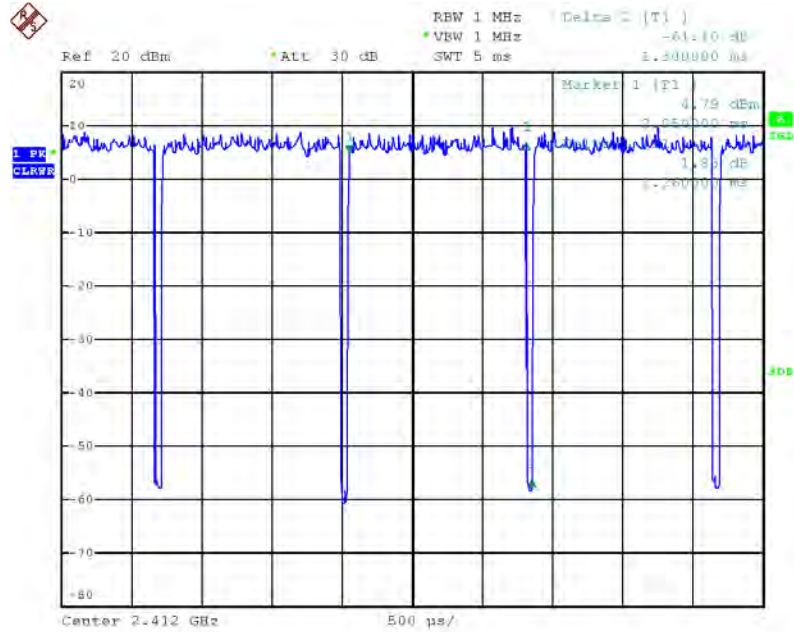

Date: 20.SEP.2013 17:36:58

IEEE 802.11n MCS0 40MHz / Chain 1

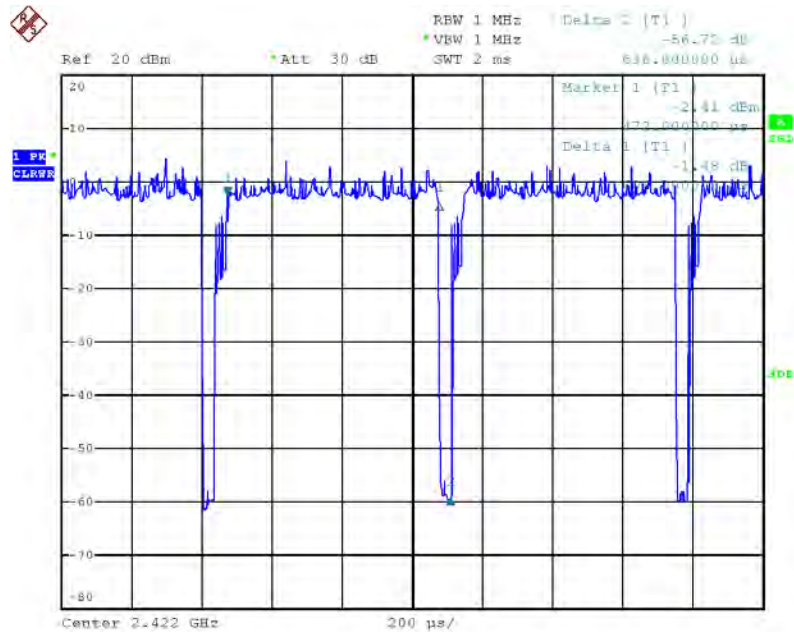

Date: 20.SEP.2013 17:38:35

IEEE 802.11n MCS0 20MHz / Chain 1 + Chain 2

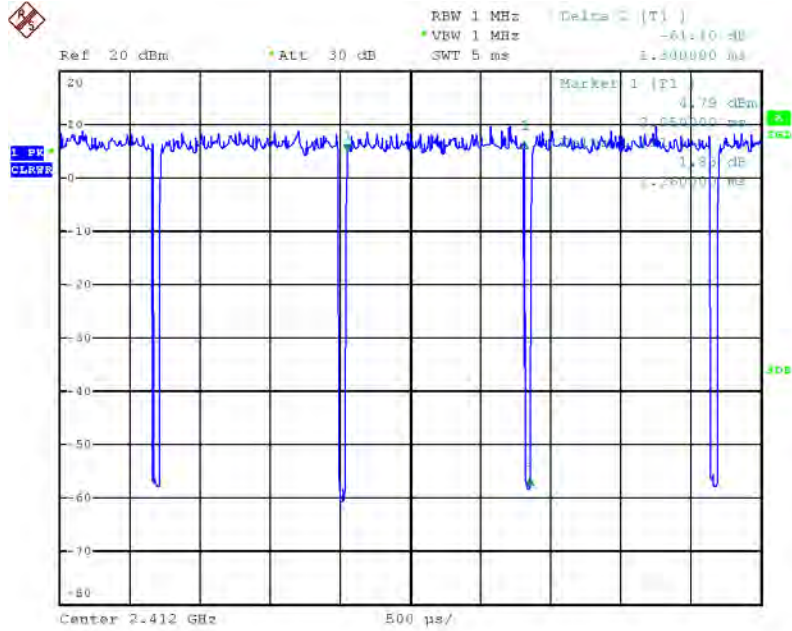

Date: 20.SEP.2013 17:36:58

IEEE 802.11n MCS0 40MHz / Chain 1 + Chain 2

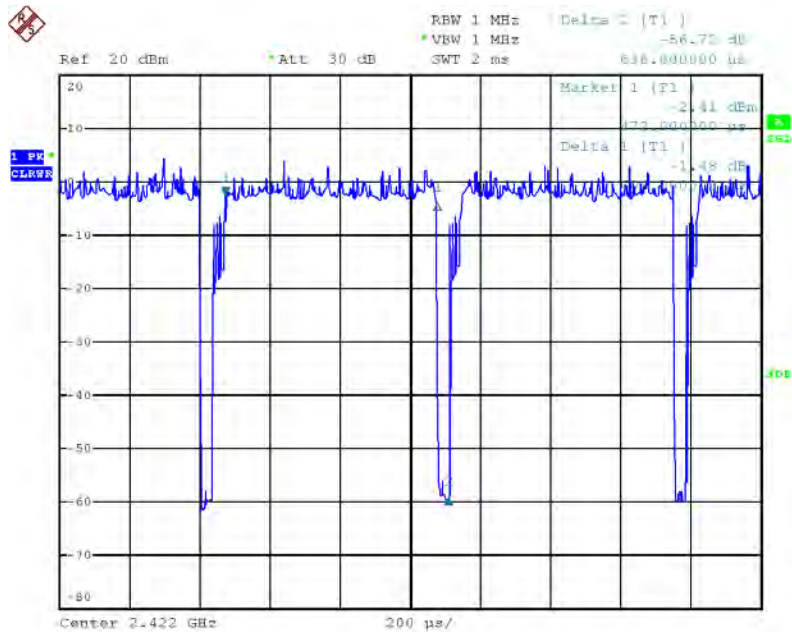

Date: 20.SEP.2013 17:38:35

IEEE 802.11n MCS0 20MHz / Chain 1 + Chain 2 + Chain 3

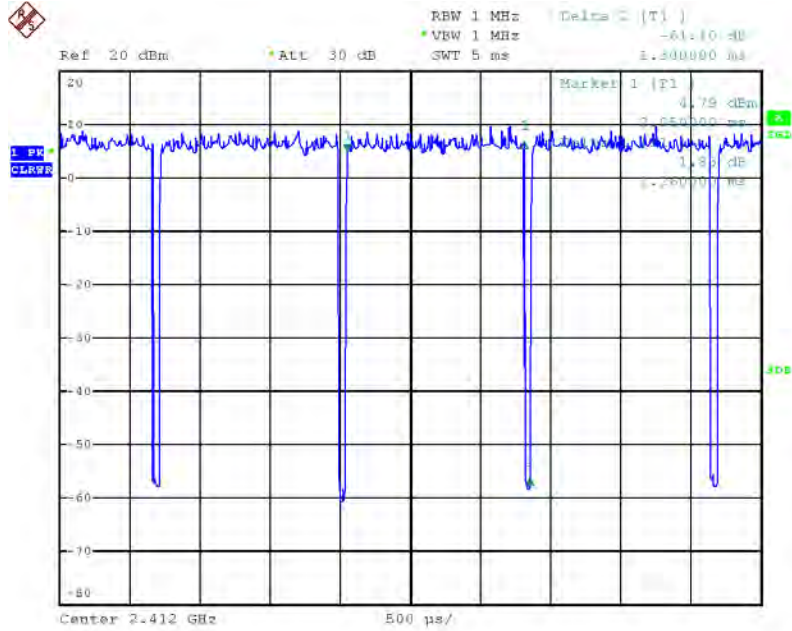

Date: 20.SEP.2013 17:36:58

IEEE 802.11n MCS0 40MHz / Chain 1 + Chain 2 + Chain 3

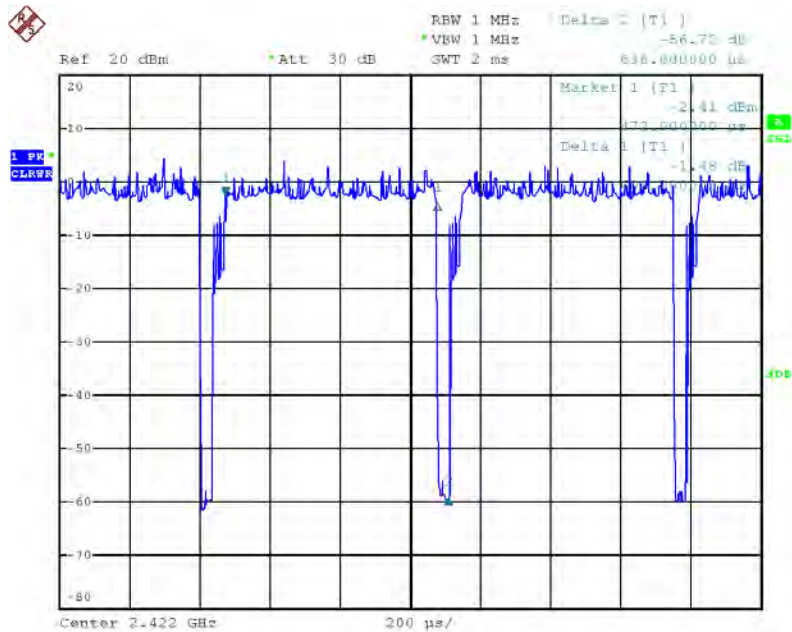

Date: 20.SEP.2013 17:38:35

IEEE 802.11n MCS8 20MHz / Chain 1 + Chain 2

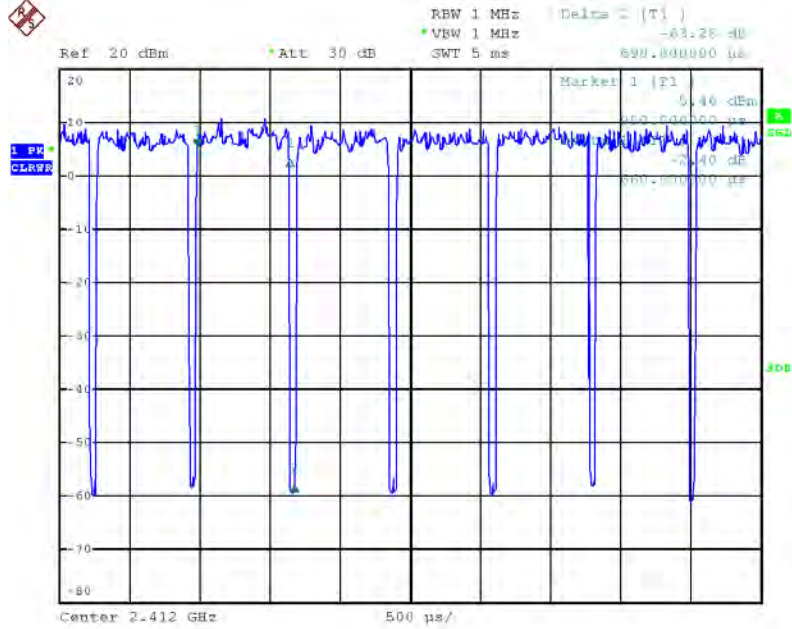

Date: 20.SEP.2013 17:46:03

IEEE 802.11n MCS8 40MHz / Chain 1 + Chain 2

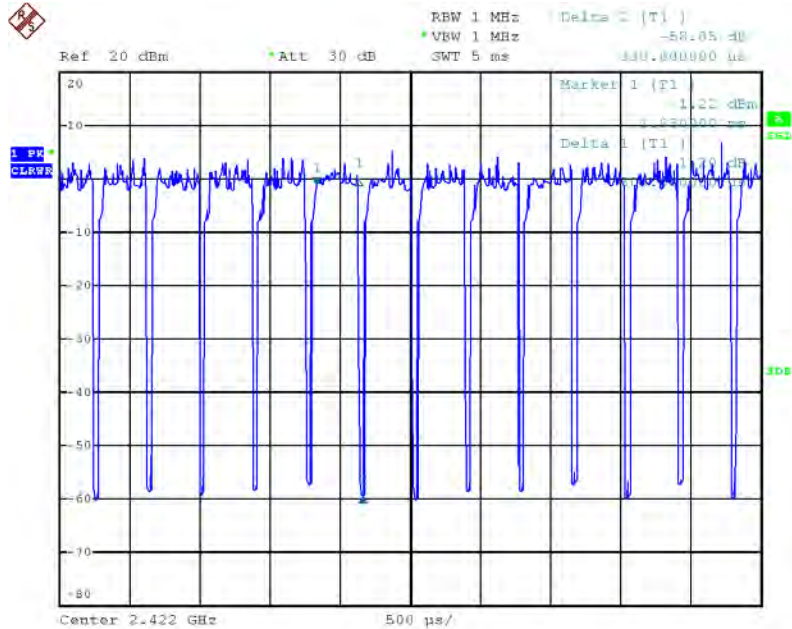

Date: 20.SEP.2013 17:48:39

IEEE 802.11n MCS8 20MHz / Chain 1 + Chain 2 + Chain 3

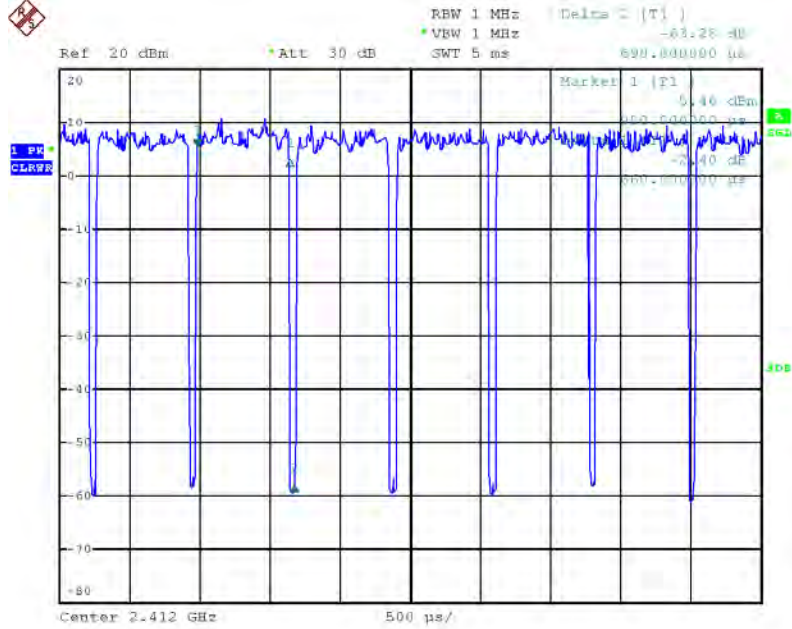

Date: 20.SEP.2013 17:46:03

IEEE 802.11n MCS8 40MHz / Chain 1 + Chain 2 + Chain 3

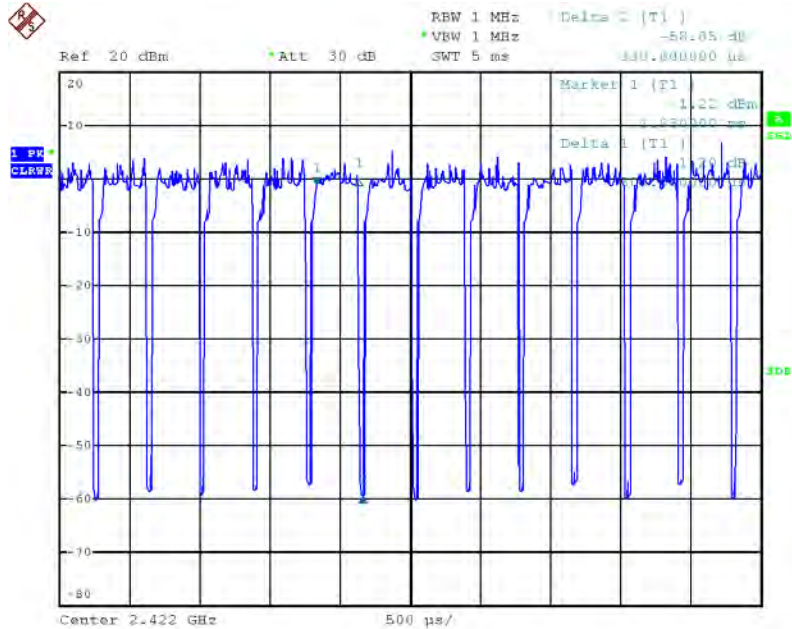

Date: 20.SEP.2013 17:48:39

IEEE 802.11n MCS16 20MHz / Chain 1 + Chain 2 + Chain 3

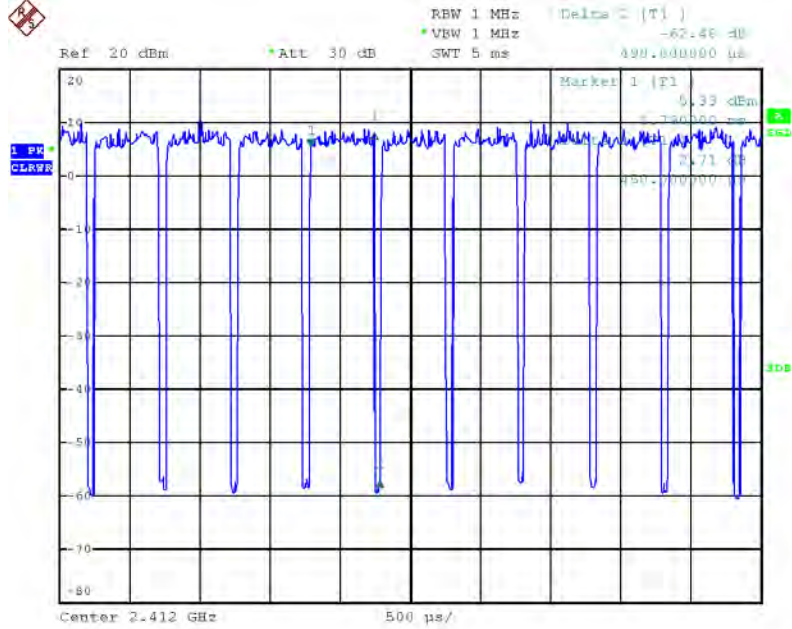

Date: 20.SEP.2013 17:47:15

IEEE 802.11n MCS16 40MHz / Chain 1 + Chain 2 + Chain 3

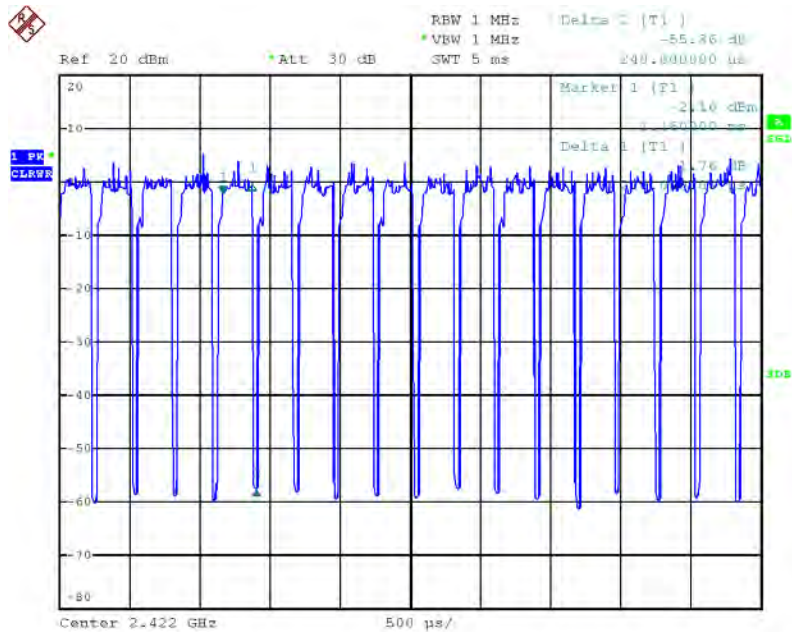

Date: 20.SEP.2013 17:49:47

IEEE 802.11b / Chain 1

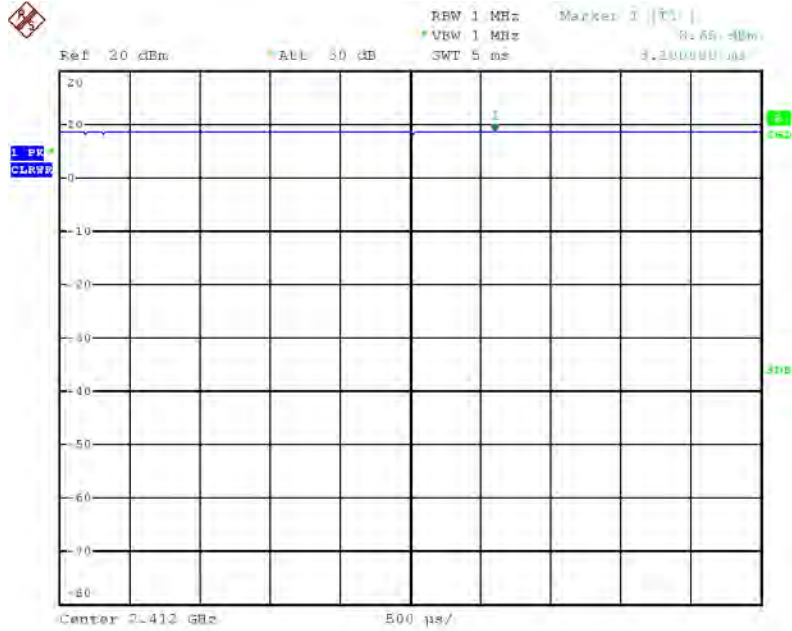

Date: 20.SEP.2013 17:42:59

IEEE 802.11b / Chain 1 + Chain 2



Date: 20.SEP.2013 17:42:59

IEEE 802.11b / Chain 1 + Chain 2 + Chain 3

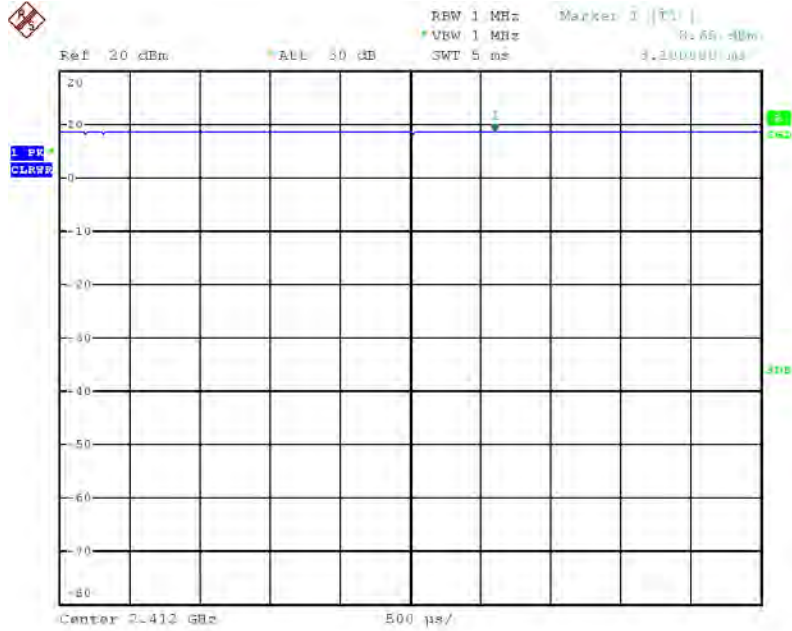

Date: 20.SEP.2013 17:42:59

IEEE 802.11g / Chain 1

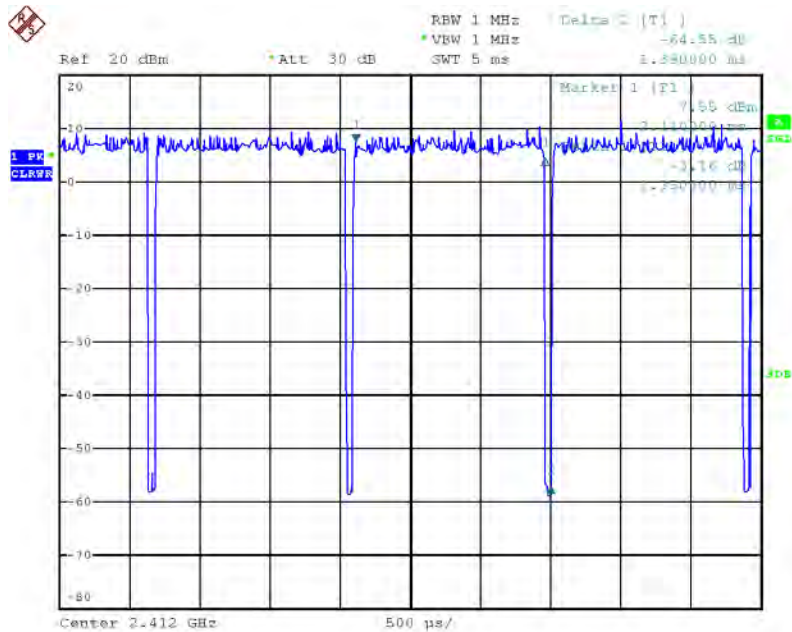

Date: 20.SEP.2013 17:35:52

IEEE 802.11g / Chain 1 + Chain 2

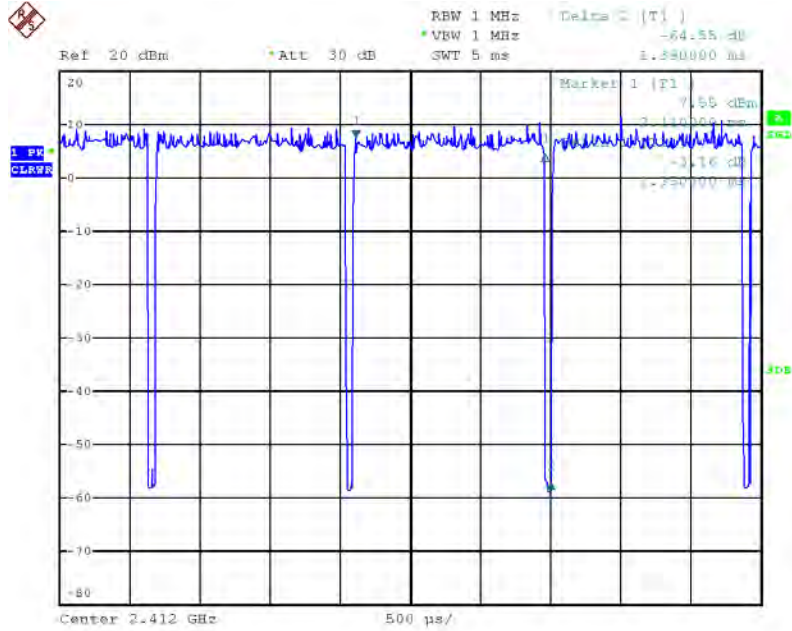

Date: 20.SEP.2013 17:35:52

IEEE 802.11g / Chain 1 + Chain 2 + Chain 3

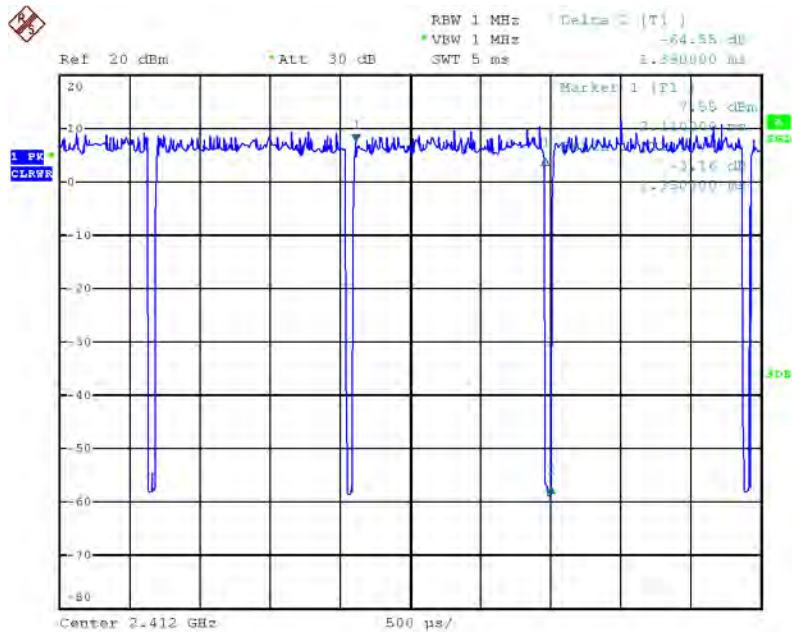

Date: 20.SEP.2013 17:35:52

For 5GHz Band:

Test Mode: Mode 2 (Ant.31 PIFA antenna / 4.7dBi)

IEEE 802.11n MCS0 20MHz / Chain 1

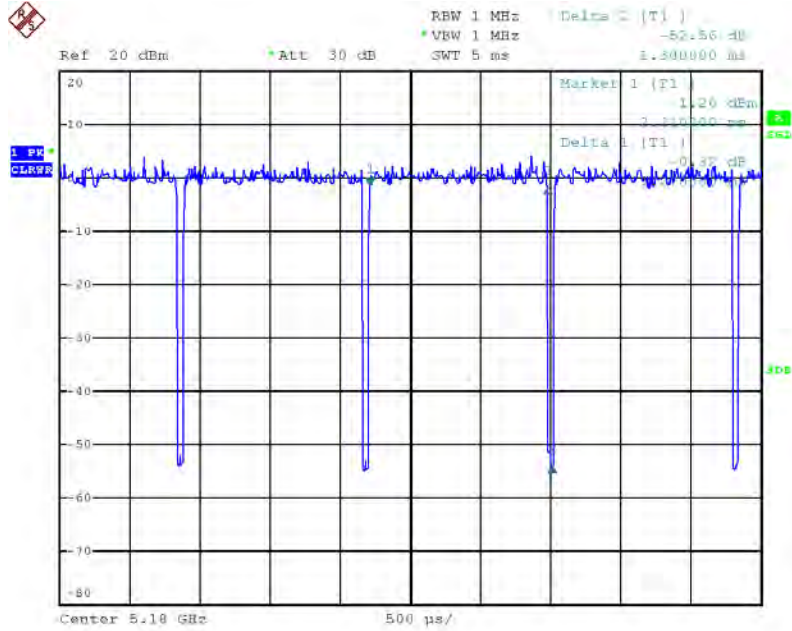

Date: 20.SEP.2013 17:40:43

IEEE 802.11n MCS0 40MHz / Chain 1

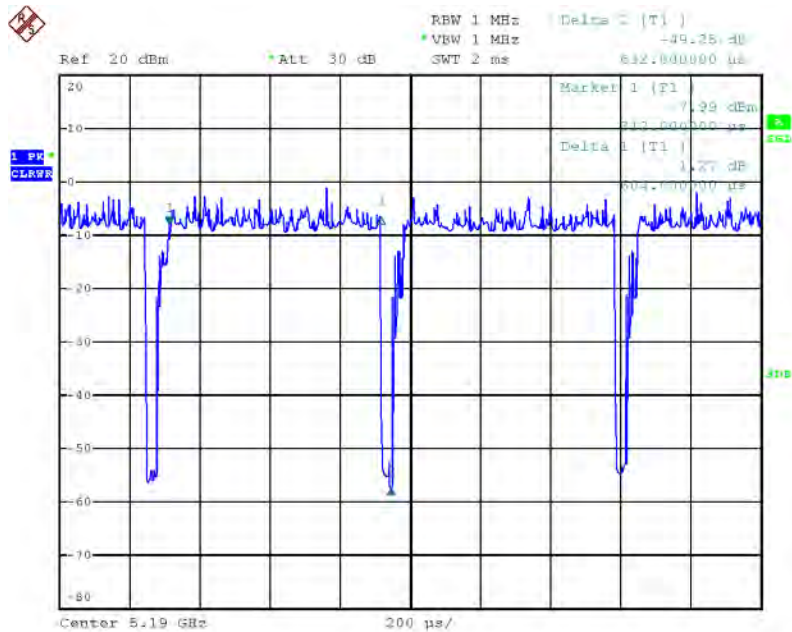

Date: 20.SEP.2013 17:39:52

IEEE 802.11n MCS8 20MHz / Chain 1 + Chain 2

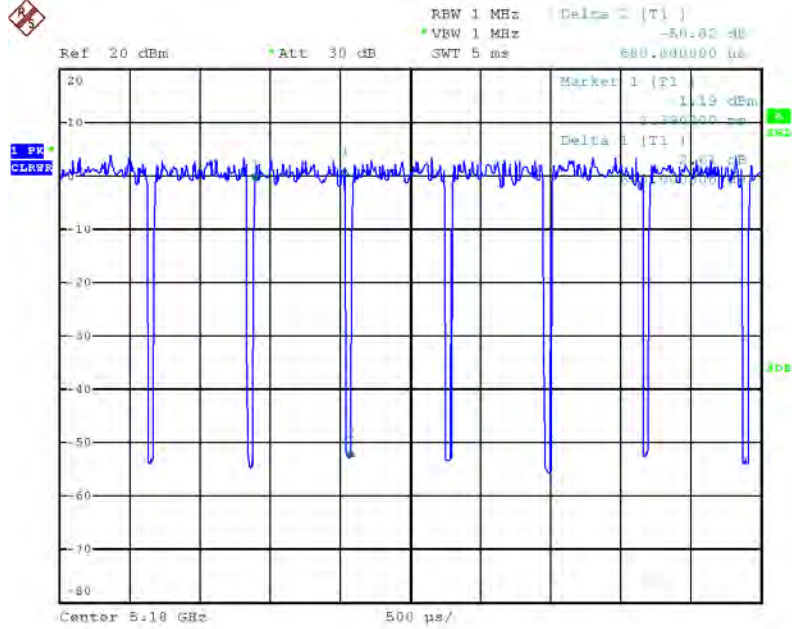

Date: 20.SEP.2013 17:52:32

IEEE 802.11n MCS8 40MHz / Chain 1 + Chain 2

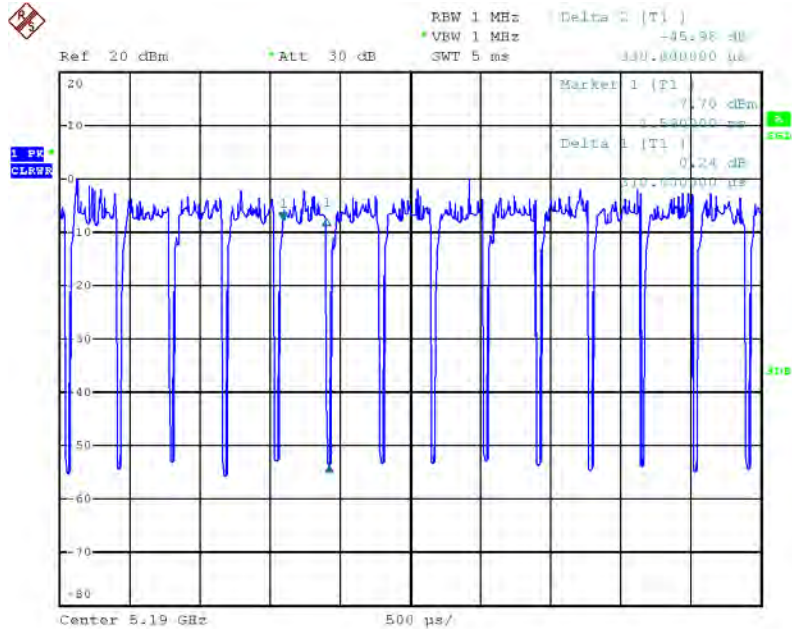

Date: 20.SEP.2013 17:50:59

IEEE 802.11n MCS16 20MHz / Chain 1 + Chain 2 + Chain 3

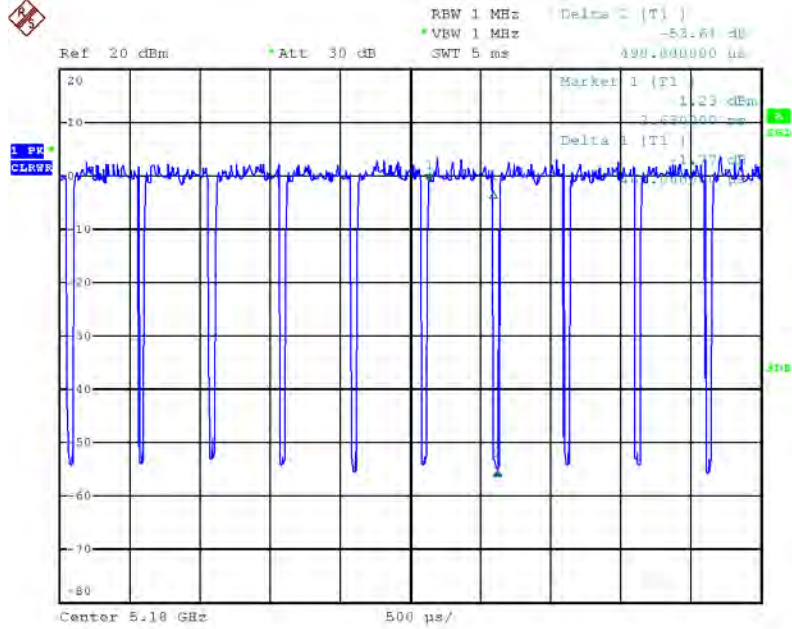

Date: 20.SEP.2013 17:53:18

IEEE 802.11n MCS16 40MHz / Chain 1 + Chain 2 + Chain 3

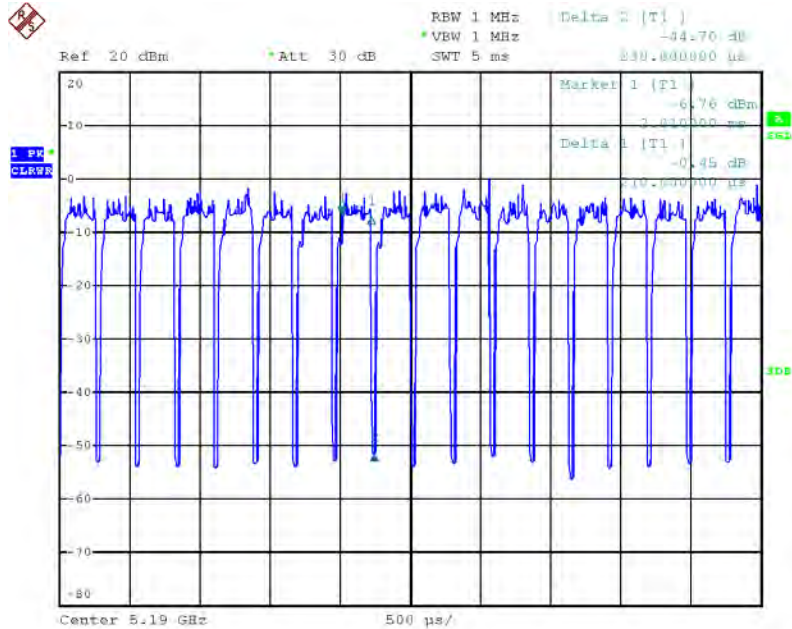

Date: 20.SEP.2013 17:51:44

IEEE 802.11a / Chain 1

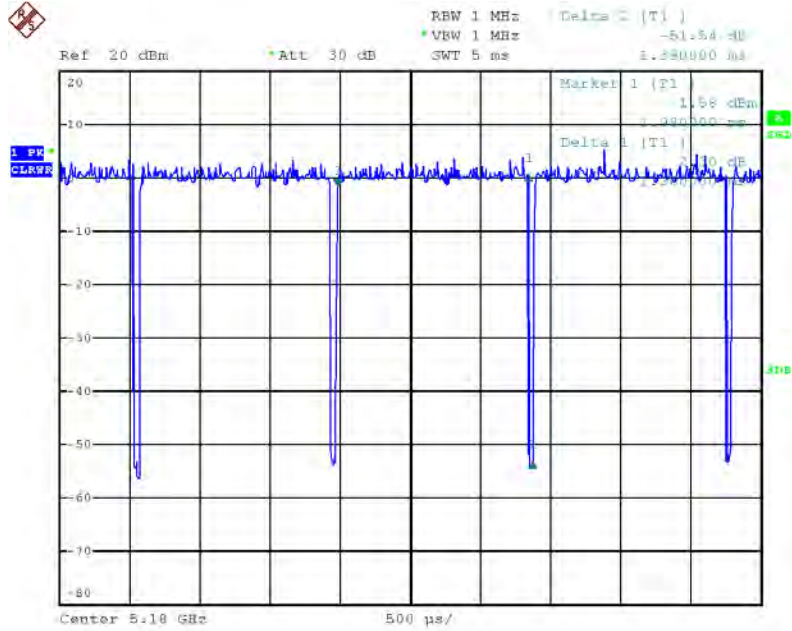

Date: 20.SEP.2013 17:41:27

3.12. Test Configurations

3.12.1. Radiation Emissions Test Configuration

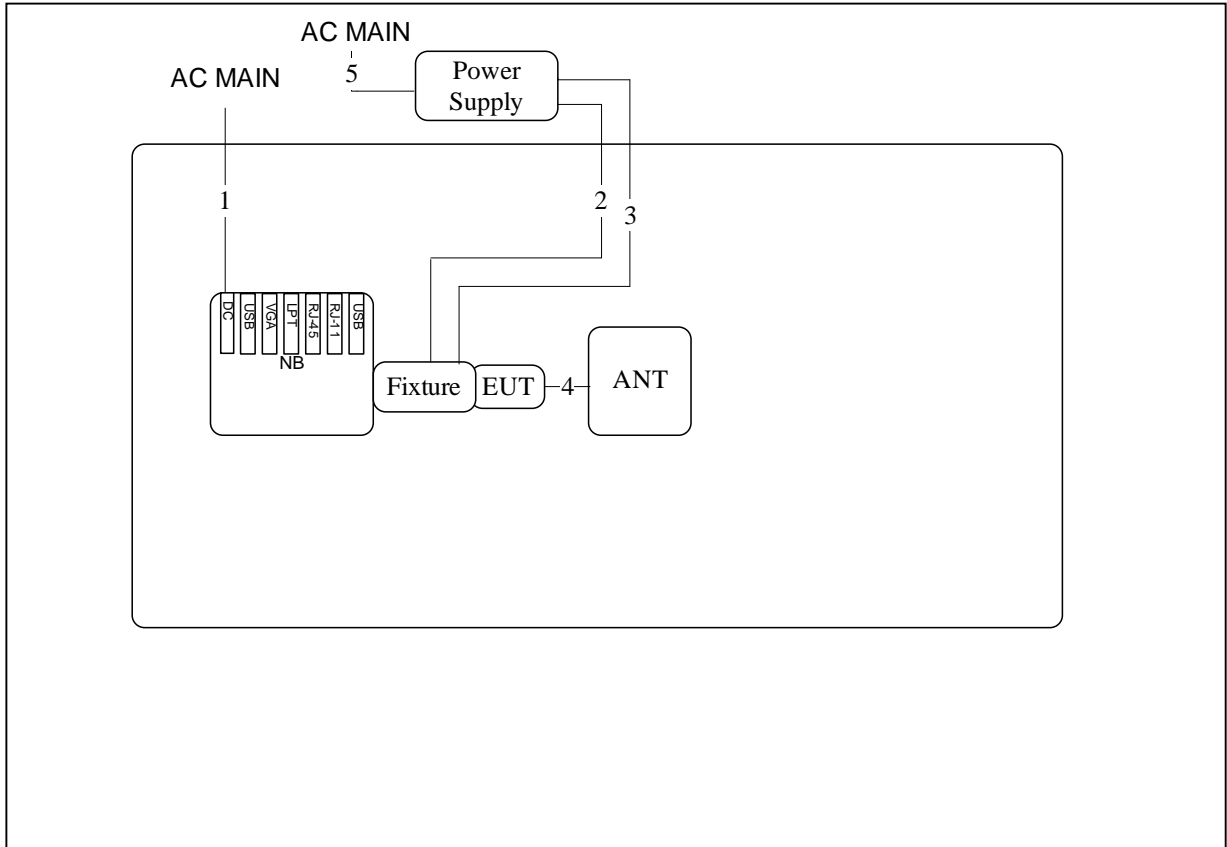

Item	Connection	Shielded	Length(m)
1	Power cable	No	1.8m
2	Power supply cable	No	1.1m
3	Power supply cable	No	1.1m
4	RF cable*3	Yes	0.15m
5	Power cable	No	1.8m

4. TEST RESULT

4.1. Maximum Conducted Output Power Measurement

4.1.1. Limit

For systems using digital modulation in the 2400-2483.5MHz, the limit for output power is 30dBm. The limited has to be reduced by the amount in dB that the gain of the antenna exceed 6dBi. In case of point-to-point operation, the limit has to be reduced by 1dB for every 3dB that the directional gain of the antenna exceeds 6dBi. Systems operating in the 5725-5850 MHz band that are used exclusively for fixed, point-to-point operations may employ transmitting antennas with directional gain greater than 6 dBi without any corresponding reduction in transmitter output power.

4.1.2. Measuring Instruments and Setting

Please refer to section 5 of equipments list in this report. The following table is the setting of the power meter.

Power Meter Parameter	Setting
Bandwidth	50MHz bandwidth is greater than the EUT emission bandwidth
Detector	Average

4.1.3. Test Procedures

1. Test procedures refer KDB 558074 D01 v03r01 section 9.2.2 Measurement using a power meter (PM).
2. This procedure provides an alternative for determining the RMS output power using a broadband RF average power meter with a thermocouple detector.

4.1.4. Test Setup Layout

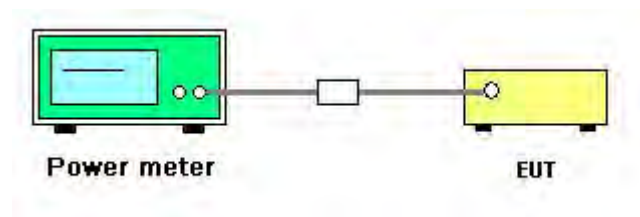

4.1.5. Test Deviation

There is no deviation with the original standard.

4.1.6. EUT Operation during Test

The EUT was programmed to be in continuously transmitting mode.

4.1.7. Test Result of Maximum Conducted Output Power

Temperature	24°C	Humidity	61%
Test Engineer	Kenneth Huang	Configurations	IEEE 802.11b/g/n
Test Date	Sep. 17, 2013 ~ Sep. 20, 2013		
Test Mode	Mode 1 (Ant.31 PIFA antenna / 4.4dBi)		

For 2.4GHz Band

Configuration IEEE 802.11n MCS0 20MHz / Chain 1

Channel	Frequency	Conducted Power (dBm)	Max. Limit (dBm)	Result
1	2412 MHz	15.92	30.00	Complies
6	2437 MHz	23.38	30.00	Complies
11	2462 MHz	18.96	30.00	Complies

Configuration IEEE 802.11n MCS0 40MHz / Chain 1

Channel	Frequency	Conducted Power (dBm)	Max. Limit (dBm)	Result
3	2422 MHz	13.15	30.00	Complies
6	2437 MHz	18.94	30.00	Complies
9	2452 MHz	16.95	30.00	Complies

Configuration IEEE 802.11n MCS0 20MHz / Chain 1 + Chain 2

Channel	Frequency	Conducted Power (dBm)			Max. Limit (dBm)	Result
		Chain 1	Chain 2	Total		
1	2412 MHz	14.66	15.07	17.88	30.00	Complies
6	2437 MHz	21.19	20.66	23.94	30.00	Complies
11	2462 MHz	17.02	15.96	19.53	30.00	Complies

Configuration IEEE 802.11n MCS0 40MHz / Chain 1 + Chain 2

Channel	Frequency	Conducted Power (dBm)			Max. Limit (dBm)	Result
		Chain 1	Chain 2	Total		
3	2422 MHz	10.91	11.31	14.12	30.00	Complies
6	2437 MHz	15.51	15.41	18.47	30.00	Complies
9	2452 MHz	12.47	11.20	14.89	30.00	Complies

Configuration IEEE 802.11n MCS0 20MHz / Chain 1 + Chain 2 + Chain 3

Channel	Frequency	Conducted Power (dBm)				Max. Limit (dBm)	Result
		Chain 1	Chain 2	Chain 3	Total		
1	2412 MHz	14.71	15.33	15.14	19.84	30.00	Complies
6	2437 MHz	15.72	14.83	14.86	19.93	30.00	Complies
11	2462 MHz	15.45	13.79	14.32	19.35	30.00	Complies

Configuration IEEE 802.11n MCS0 40MHz / Chain 1 + Chain 2 + Chain 3

Channel	Frequency	Conducted Power (dBm)				Max. Limit (dBm)	Result
		Chain 1	Chain 2	Chain 3	Total		
3	2422 MHz	12.08	12.72	12.92	17.36	30.00	Complies
6	2437 MHz	16.34	16.02	15.76	20.82	30.00	Complies
9	2452 MHz	13.86	12.89	12.80	17.98	30.00	Complies

Configuration IEEE 802.11n MCS8 20MHz / Chain 1 + Chain 2

Channel	Frequency	Conducted Power (dBm)			Max. Limit (dBm)	Result
		Chain 1	Chain 2	Total		
1	2412 MHz	15.60	15.74	18.68	30.00	Complies
6	2437 MHz	20.61	20.42	23.53	30.00	Complies
11	2462 MHz	16.73	15.88	19.34	30.00	Complies

Configuration IEEE 802.11n MCS8 40MHz / Chain 1 + Chain 2

Channel	Frequency	Conducted Power (dBm)			Max. Limit (dBm)	Result
		Chain 1	Chain 2	Total		
3	2422 MHz	12.02	12.52	15.29	30.00	Complies
6	2437 MHz	16.86	16.68	19.78	30.00	Complies
9	2452 MHz	14.40	13.34	16.91	30.00	Complies

Configuration IEEE 802.11n MCS8 20MHz / Chain 1 + Chain 2 + Chain 3

Channel	Frequency	Conducted Power (dBm)				Max. Limit (dBm)	Result
		Chain 1	Chain 2	Chain 3	Total		
1	2412 MHz	15.57	16.17	16.14	20.74	30.00	Complies
6	2437 MHz	15.61	15.13	15.08	20.05	30.00	Complies
11	2462 MHz	14.56	13.26	13.61	18.62	30.00	Complies

Configuration IEEE 802.11n MCS8 40MHz / Chain 1 + Chain 2 + Chain 3

Channel	Frequency	Conducted Power (dBm)				Max. Limit (dBm)	Result
		Chain 1	Chain 2	Chain 3	Total		
3	2422 MHz	12.45	13.10	13.24	17.71	30.00	Complies
6	2437 MHz	16.50	16.24	15.88	20.99	30.00	Complies
9	2452 MHz	14.22	12.91	12.88	18.15	30.00	Complies

Configuration IEEE 802.11n MCS16 20MHz / Chain 1 + Chain 2 + Chain 3

Channel	Frequency	Conducted Power (dBm)				Max. Limit (dBm)	Result
		Chain 1	Chain 2	Chain 3	Total		
1	2412 MHz	15.26	15.76	15.70	20.35	30.00	Complies
6	2437 MHz	14.48	13.44	13.64	18.65	30.00	Complies
11	2462 MHz	14.03	12.61	13.03	18.04	30.00	Complies

Configuration IEEE 802.11n MCS16 40MHz / Chain 1 + Chain 2 + Chain 3

Channel	Frequency	Conducted Power (dBm)				Max. Limit (dBm)	Result
		Chain 1	Chain 2	Chain 3	Total		
3	2422 MHz	11.32	11.83	11.98	16.49	30.00	Complies
6	2437 MHz	15.87	15.58	15.23	20.34	30.00	Complies
9	2452 MHz	13.15	11.82	11.79	17.07	30.00	Complies

Configuration IEEE 802.11b / Chain 1

Channel	Frequency	Conducted Power (dBm)	Max. Limit (dBm)	Result
1	2412 MHz	22.82	30.00	Complies
6	2437 MHz	22.78	30.00	Complies
11	2462 MHz	21.14	30.00	Complies

Configuration IEEE 802.11b / Chain 1 + Chain 2

Channel	Frequency	Conducted Power (dBm)			Max. Limit (dBm)	Result
		Chain 1	Chain 2	Total		
1	2412 MHz	19.49	20.15	22.84	30.00	Complies
6	2437 MHz	21.43	20.48	23.99	30.00	Complies
11	2462 MHz	17.89	17.17	20.56	30.00	Complies

Configuration IEEE 802.11b / Chain 1 + Chain 2 + Chain 3

Channel	Frequency	Conducted Power (dBm)				Max. Limit (dBm)	Result
		Chain 1	Chain 2	Chain 3	Total		
1	2412 MHz	14.88	15.29	15.19	19.89	30.00	Complies
6	2437 MHz	17.62	16.67	16.78	21.82	30.00	Complies
11	2462 MHz	16.79	14.99	15.51	20.60	30.00	Complies

Configuration IEEE 802.11g / Chain 1

Channel	Frequency	Conducted Power (dBm)	Max. Limit (dBm)	Result
1	2412 MHz	18.73	30.00	Complies
6	2437 MHz	23.57	30.00	Complies
11	2462 MHz	18.72	30.00	Complies

Configuration IEEE 802.11g / Chain 1 + Chain 2

Channel	Frequency	Conducted Power (dBm)			Max. Limit (dBm)	Result
		Chain 1	Chain 2	Total		
1	2412 MHz	15.13	15.63	18.40	30.00	Complies
6	2437 MHz	21.19	20.94	24.08	30.00	Complies
11	2462 MHz	17.63	16.79	20.24	30.00	Complies

Configuration IEEE 802.11g / Chain 1 + Chain 2 + Chain 3

Channel	Frequency	Conducted Power (dBm)				Max. Limit (dBm)	Result
		Chain 1	Chain 2	Chain 3	Total		
1	2412 MHz	15.67	16.33	16.15	20.83	30.00	Complies
6	2437 MHz	15.73	14.96	14.91	19.99	30.00	Complies
11	2462 MHz	15.07	13.51	13.82	18.96	30.00	Complies

Temperature	24°C	Humidity	61%
Test Engineer	Kenneth Huang	Configurations	IEEE 802.11a/n
Test Date	Sep. 17, 2013 ~ Sep. 20, 2013		
Test Mode	Mode 2 (Ant.31 PIFA antenna / 4.7dBi)		

For 5GHz Band
Configuration IEEE 802.11n MCS0 20MHz / Chain 1

Channel	Frequency	Conducted Power (dBm)	Max. Limit (dBm)	Result
149	5745 MHz	22.09	30.00	Complies
157	5785 MHz	22.16	30.00	Complies
165	5825 MHz	22.12	30.00	Complies

Configuration IEEE 802.11n MCS0 40MHz / Chain 1

Channel	Frequency	Conducted Power (dBm)	Max. Limit (dBm)	Result
151	5755 MHz	22.08	30.00	Complies
159	5795 MHz	22.06	30.00	Complies

Configuration IEEE 802.11n MCS8 20MHz / Chain 1 + Chain 2

Channel	Frequency	Conducted Power (dBm)			Max. Limit (dBm)	Result
		Chain 1	Chain 2	Total		
149	5745 MHz	20.18	20.32	23.26	30.00	Complies
157	5785 MHz	19.34	19.13	22.25	30.00	Complies
165	5825 MHz	17.26	16.92	20.10	30.00	Complies

Configuration IEEE 802.11n MCS8 40MHz / Chain 1 + Chain 2

Channel	Frequency	Conducted Power (dBm)			Max. Limit (dBm)	Result
		Chain 1	Chain 2	Total		
151	5755 MHz	20.42	20.25	23.35	30.00	Complies
159	5795 MHz	19.31	18.86	22.10	30.00	Complies

Configuration IEEE 802.11n MCS16 20MHz / Chain 1 + Chain 2 + Chain 3

Channel	Frequency	Conducted Power (dBm)				Max. Limit (dBm)	Result
		Chain 1	Chain 2	Chain 3	Total		
149	5745 MHz	18.36	19.74	19.77	24.11	30.00	Complies
157	5785 MHz	18.45	18.28	18.92	23.33	30.00	Complies
165	5825 MHz	17.51	17.53	17.53	22.29	30.00	Complies

Configuration IEEE 802.11n MCS16 40MHz / Chain 1 + Chain 2 + Chain 3

Channel	Frequency	Conducted Power (dBm)				Max. Limit (dBm)	Result
		Chain 1	Chain 2	Chain 3	Total		
151	5755 MHz	18.10	19.66	19.82	24.03	30.00	Complies
159	5795 MHz	18.74	18.63	19.00	23.56	30.00	Complies

Configuration IEEE 802.11a / Chain 1

Channel	Frequency	Conducted Power (dBm)	Max. Limit (dBm)	Result
149	5745 MHz	22.14	30.00	Complies
157	5785 MHz	22.28	30.00	Complies
165	5825 MHz	22.11	30.00	Complies

4.2. Power Spectral Density Measurement

4.2.1. Limit

For digitally modulated systems, the power spectral density conducted from the intentional radiator to the antenna shall not be greater than 8dBm in any 3 kHz band during any time interval of continuous transmission.

4.2.2. Measuring Instruments and Setting

Please refer to section 5 of equipments list in this report. The following table is the setting of the spectrum analyzer.

Spectrum Parameter	Setting
Attenuation	Auto
Span Frequency	Set the span to 1.5 times the DTS channel bandwidth.
RBW	$3 \text{ kHz} \leq \text{RBW} \leq 100\text{kHz}$
VBW	$\geq 3 \times \text{RBW}$
Detector	Peak
Trace	Max Hold
Sweep Time	Auto couple

4.2.3. Test Procedures

1. Test procedures refer KDB 558074 D01 v03r01 section 10.2 Method PKPSD (peak PSD) and KDB 662911 D01 v02 section In-Band Power Spectral Density (PSD) Measurements option (b) Measure and sum spectral maximal across the outputs.
2. Use this procedure when the maximum conducted output power in the fundamental emission is used to demonstrate compliance. The EUT must be configured to transmit continuously at full power over the measurement duration.
3. Ensure that the number of measurement points in the sweep $\geq 2 \times \text{span}/\text{RBW}$ (use of a greater number of measurement points than this minimum requirement is recommended).
4. Use the peak marker function to determine the maximum level in any 3 kHz band segment within the fundamental EBW.
5. The resulting PSD level must be $\leq 8 \text{ dBm}$.

4.2.4. Test Setup Layout

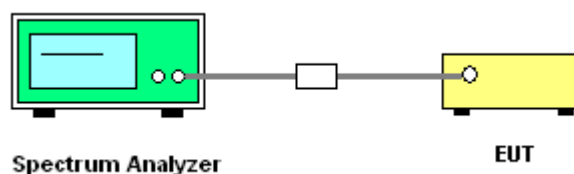

4.2.5. Test Deviation

There is no deviation with the original standard.

4.2.6. EUT Operation during Test

The EUT was programmed to be in continuously transmitting mode.

4.2.7. Test Result of Power Spectral Density

Temperature	24°C	Humidity	61%
Test Engineer	Kenneth Huang	Configurations	IEEE 802.11b/g/n
Test Mode	Mode 1 (Ant.31 PIFA antenna / 4.4dBi)		

For 2.4GHz Band

Configuration IEEE 802.11n MCS0 20MHz / Chain 1

Channel	Frequency	Power Density (dBm/3kHz)	Power Density Limit (dBm/3kHz)	Result
1	2412 MHz	-10.02	8.00	Complies
6	2437 MHz	-2.98	8.00	Complies
11	2462 MHz	-7.41	8.00	Complies

Configuration IEEE 802.11n MCS0 40MHz / Chain 1

Channel	Frequency	Power Density (dBm/3kHz)	Power Density Limit (dBm/3kHz)	Result
3	2422 MHz	-16.04	8.00	Complies
6	2437 MHz	-9.63	8.00	Complies
9	2452 MHz	-12.48	8.00	Complies

Configuration IEEE 802.11n MCS0 20MHz / Chain 1 + Chain 2

Channel	Frequency	Power Density (dBm/3kHz)			Power Density Limit (dBm/3kHz)	Result
		Chain 1	Chain 2	Total		
1	2412 MHz	-10.59	-10.19	-7.38	8.00	Complies
6	2437 MHz	-4.82	-4.82	-1.81	8.00	Complies
11	2462 MHz	-9.15	-9.87	-6.48	8.00	Complies

Configuration IEEE 802.11n MCS0 40MHz / Chain 1 + Chain 2

Channel	Frequency	Power Density (dBm/3kHz)			Power Density Limit (dBm/3kHz)	Result
		Chain 1	Chain 2	Total		
3	2422 MHz	-17.77	-17.33	-14.53	8.00	Complies
6	2437 MHz	-12.73	-12.80	-9.75	8.00	Complies
9	2452 MHz	-15.11	-16.88	-12.90	8.00	Complies

Configuration IEEE 802.11n MCS0 20MHz / Chain 1 + Chain 2 + Chain 3

Channel	Frequency	Power Density (dBm/3kHz)				Power Density Limit (dBm/3kHz)	Result
		Chain 1	Chain 2	Chain 3	Total		
1	2412 MHz	-10.62	-10.52	-9.72	-5.50	8.00	Complies
6	2437 MHz	-9.44	-10.55	-9.28	-4.95	8.00	Complies
11	2462 MHz	-10.00	-12.53	-11.19	-6.35	8.00	Complies

Configuration IEEE 802.11n MCS0 40MHz / Chain 1 + Chain 2 + Chain 3

Channel	Frequency	Power Density (dBm/3kHz)				Power Density Limit (dBm/3kHz)	Result
		Chain 1	Chain 2	Chain 3	Total		
3	2422 MHz	-14.46	-14.56	-14.38	-9.69	8.00	Complies
6	2437 MHz	-11.44	-11.70	-11.82	-6.88	8.00	Complies
9	2452 MHz	-14.08	-16.40	-16.05	-10.61	8.00	Complies

Configuration IEEE 802.11n MCS8 20MHz / Chain 1 + Chain 2

Channel	Frequency	Power Density (dBm/3kHz)			Power Density Limit (dBm/3kHz)	Result
		Chain 1	Chain 2	Total		
1	2412 MHz	-10.42	-11.04	-7.71	8.00	Complies
6	2437 MHz	-3.69	-5.43	-1.46	8.00	Complies
11	2462 MHz	-9.78	-10.71	-7.21	8.00	Complies

Configuration IEEE 802.11n MCS8 40MHz / Chain 1 + Chain 2

Channel	Frequency	Power Density (dBm/3kHz)			Power Density Limit (dBm/3kHz)	Result
		Chain 1	Chain 2	Total		
3	2422 MHz	-15.71	-14.29	-11.93	8.00	Complies
6	2437 MHz	-11.35	-12.16	-8.73	8.00	Complies
9	2452 MHz	-13.42	-15.41	-11.29	8.00	Complies

Configuration IEEE 802.11n MCS8 20MHz / Chain 1 + Chain 2 + Chain 3

Channel	Frequency	Power Density (dBm/3kHz)				Power Density Limit (dBm/3kHz)	Result
		Chain 1	Chain 2	Chain 3	Total		
1	2412 MHz	-9.28	-9.75	-8.49	-4.37	8.00	Complies
6	2437 MHz	-8.91	-10.77	-9.37	-4.84	8.00	Complies
11	2462 MHz	-11.07	-11.50	-11.40	-6.55	8.00	Complies

Configuration IEEE 802.11n MCS8 40MHz / Chain 1 + Chain 2 + Chain 3

Channel	Frequency	Power Density (dBm/3kHz)				Power Density Limit (dBm/3kHz)	Result
		Chain 1	Chain 2	Chain 3	Total		
3	2422 MHz	-15.24	-15.82	-14.85	-10.51	8.00	Complies
6	2437 MHz	-11.31	-10.64	-12.09	-6.54	8.00	Complies
9	2452 MHz	-13.64	-15.57	-15.65	-10.08	8.00	Complies

Configuration IEEE 802.11n MCS16 20MHz / Chain 1 + Chain 2 + Chain 3

Channel	Frequency	Power Density (dBm/3kHz)				Power Density Limit (dBm/3kHz)	Result
		Chain 1	Chain 2	Chain 3	Total		
1	2412 MHz	-9.88	-9.81	-9.25	-4.87	8.00	Complies
6	2437 MHz	-9.37	-11.73	-11.77	-6.03	8.00	Complies
11	2462 MHz	-11.46	-12.28	-12.55	-7.30	8.00	Complies

Configuration IEEE 802.11n MCS16 40MHz / Chain 1 + Chain 2 + Chain 3

Channel	Frequency	Power Density (dBm/3kHz)				Power Density Limit (dBm/3kHz)	Result
		Chain 1	Chain 2	Chain 3	Total		
3	2422 MHz	-16.49	-14.92	-15.14	-10.69	8.00	Complies
6	2437 MHz	-11.89	-12.88	-11.94	-7.44	8.00	Complies
9	2452 MHz	-14.79	-16.19	-14.26	-10.24	8.00	Complies

Configuration IEEE 802.11b / Chain 1

Channel	Frequency	Power Density (dBm/3kHz)	Power Density Limit (dBm/3kHz)	Result
1	2412 MHz	-1.73	8.00	Complies
6	2437 MHz	-1.18	8.00	Complies
11	2462 MHz	-3.40	8.00	Complies

Configuration IEEE 802.11b / Chain 1 + Chain 2

Channel	Frequency	Power Density (dBm/3kHz)			Power Density Limit (dBm/3kHz)	Result
		Chain 1	Chain 2	Total		
1	2412 MHz	-4.68	-4.68	-1.67	8.00	Complies
6	2437 MHz	-3.14	-4.22	-0.64	8.00	Complies
11	2462 MHz	-6.85	-6.62	-3.72	8.00	Complies

Configuration IEEE 802.11b / Chain 1 + Chain 2 + Chain 3

Channel	Frequency	Power Density (dBm/3kHz)				Power Density Limit (dBm/3kHz)	Result
		Chain 1	Chain 2	Chain 3	Total		
1	2412 MHz	-8.35	-9.62	-8.36	-3.97	8.00	Complies
6	2437 MHz	-5.36	-7.43	-7.00	-1.73	8.00	Complies
11	2462 MHz	-6.55	-8.88	-7.14	-2.64	8.00	Complies

Configuration IEEE 802.11g / Chain 1

Channel	Frequency	Power Density (dBm/3kHz)	Power Density Limit (dBm/3kHz)	Result
1	2412 MHz	-7.08	8.00	Complies
6	2437 MHz	-1.65	8.00	Complies
11	2462 MHz	-6.75	8.00	Complies

Configuration IEEE 802.11g / Chain 1 + Chain 2

Channel	Frequency	Power Density (dBm/3kHz)			Power Density Limit (dBm/3kHz)	Result
		Chain 1	Chain 2	Total		
1	2412 MHz	-10.95	-10.12	-7.50	8.00	Complies
6	2437 MHz	-4.44	-3.93	-1.17	8.00	Complies
11	2462 MHz	-7.66	-8.93	-5.24	8.00	Complies

Configuration IEEE 802.11g / Chain 1 + Chain 2 + Chain 3

Channel	Frequency	Power Density (dBm/3kHz)				Power Density Limit (dBm/3kHz)	Result
		Chain 1	Chain 2	Chain 3	Total		
1	2412 MHz	-7.86	-10.02	-8.56	-3.95	8.00	Complies
6	2437 MHz	-8.69	-9.82	-9.40	-4.51	8.00	Complies
11	2462 MHz	-9.93	-10.78	-10.47	-5.61	8.00	Complies

Temperature	24°C	Humidity	61%
Test Engineer	Kenneth Huang	Configurations	IEEE 802.11a/n
Test Mode	Mode 2 (Ant.31 PIFA antenna / 4.7dBi)		

For 5GHz Band
Configuration IEEE 802.11n MCS0 20MHz / Chain 1

Channel	Frequency	Power Density (dBm/3kHz)	Power Density Limit (dBm/3kHz)	Result
149	5745 MHz	-4.87	8.00	Complies
157	5785 MHz	-5.26	8.00	Complies
165	5825 MHz	-4.47	8.00	Complies

Configuration IEEE 802.11n MCS0 40MHz / Chain 1

Channel	Frequency	Power Density (dBm/3kHz)	Power Density Limit (dBm/3kHz)	Result
151	5755 MHz	-7.90	8.00	Complies
159	5795 MHz	-7.56	8.00	Complies

Configuration IEEE 802.11n MCS8 20MHz / Chain 1 + Chain 2

Channel	Frequency	Power Density (dBm/3kHz)			Power Density Limit (dBm/3kHz)	Result
		Chain 1	Chain 2	Total		
149	5745 MHz	-5.86	-6.04	-2.94	8.00	Complies
157	5785 MHz	-6.97	-5.78	-3.32	8.00	Complies
165	5825 MHz	-8.03	-9.26	-5.59	8.00	Complies

Configuration IEEE 802.11n MCS8 40MHz / Chain 1 + Chain 2

Channel	Frequency	Power Density (dBm/3kHz)			Power Density Limit (dBm/3kHz)	Result
		Chain 1	Chain 2	Total		
151	5755 MHz	-7.28	-8.96	-5.03	8.00	Complies
159	5795 MHz	-9.15	-10.58	-6.80	8.00	Complies

Configuration IEEE 802.11n MCS16 20MHz / Chain 1 + Chain 2 + Chain 3

Channel	Frequency	Power Density (dBm/3kHz)				Power Density Limit (dBm/3kHz)	Result
		Chain 1	Chain 2	Chain 3	Total		
149	5745 MHz	-6.13	-5.78	-4.65	-0.70	8.00	Complies
157	5785 MHz	-7.99	-7.96	-8.42	-3.35	8.00	Complies
165	5825 MHz	-9.11	-9.74	-9.10	-4.54	8.00	Complies

Configuration IEEE 802.11n MCS16 40MHz / Chain 1 + Chain 2 + Chain 3

Channel	Frequency	Power Density (dBm/3kHz)				Power Density Limit (dBm/3kHz)	Result
		Chain 1	Chain 2	Chain 3	Total		
151	5755 MHz	-9.55	-8.75	-9.40	-4.45	8.00	Complies
159	5795 MHz	-9.20	-10.02	-9.99	-4.95	8.00	Complies

Configuration IEEE 802.11a

Channel	Frequency	Power Density (dBm/3kHz)	Power Density Limit (dBm/3kHz)	Result
149	5745 MHz	-3.88	8.00	Complies
157	5785 MHz	-4.28	8.00	Complies
165	5825 MHz	-4.59	8.00	Complies

Note: All the test values were listed in the report.

For plots, only the channel with worse result was shown.

For 2.4GHz Band

Power Density Plot on Configuration IEEE 802.11n MCS0 20MHz / 2437 MHz / 1TX / Chain 1

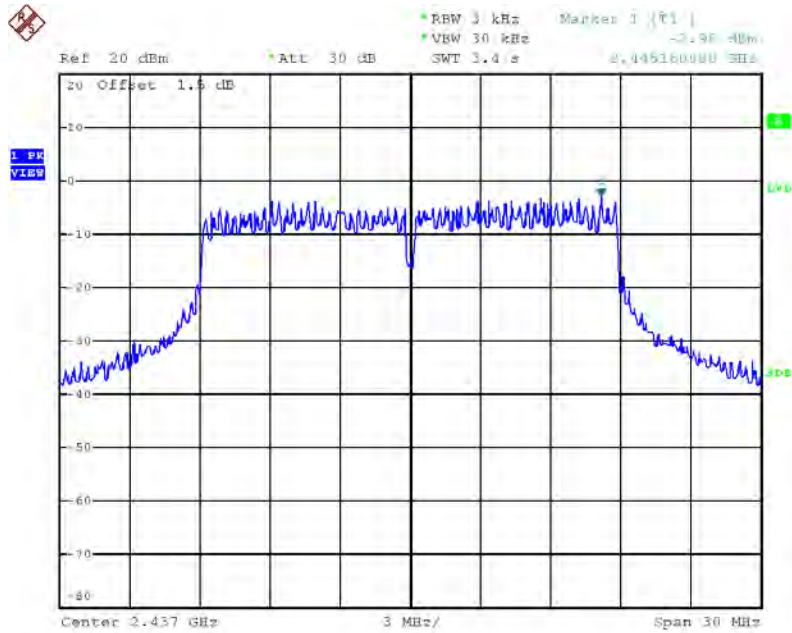

Date: 20.SEP.2013 12:15:45

Power Density Plot on Configuration IEEE 802.11n MCS0 40MHz / 2437 MHz / 1TX / Chain 1

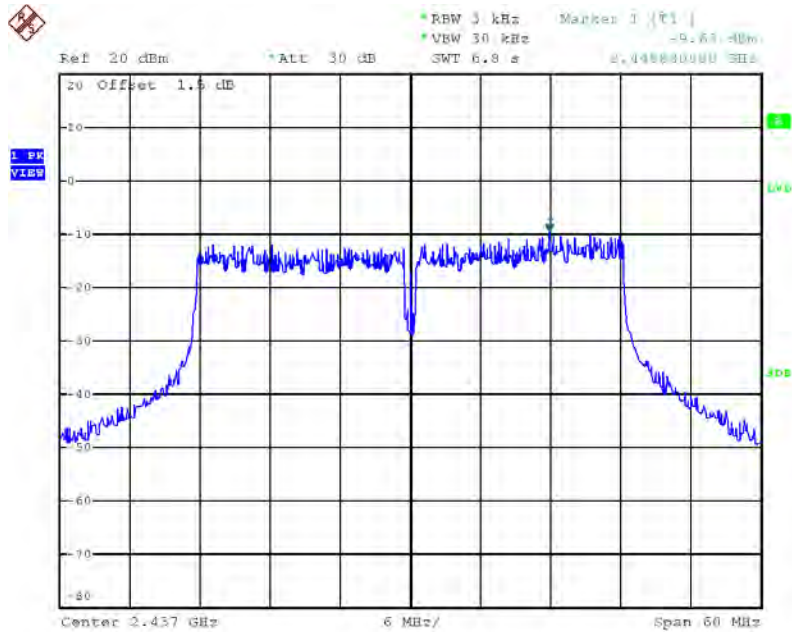

Date: 20.SEP.2013 12:19:56

Power Density Plot on Configuration IEEE 802.11n MCS0 20MHz / 2437 MHz / 2TX / Chain 1

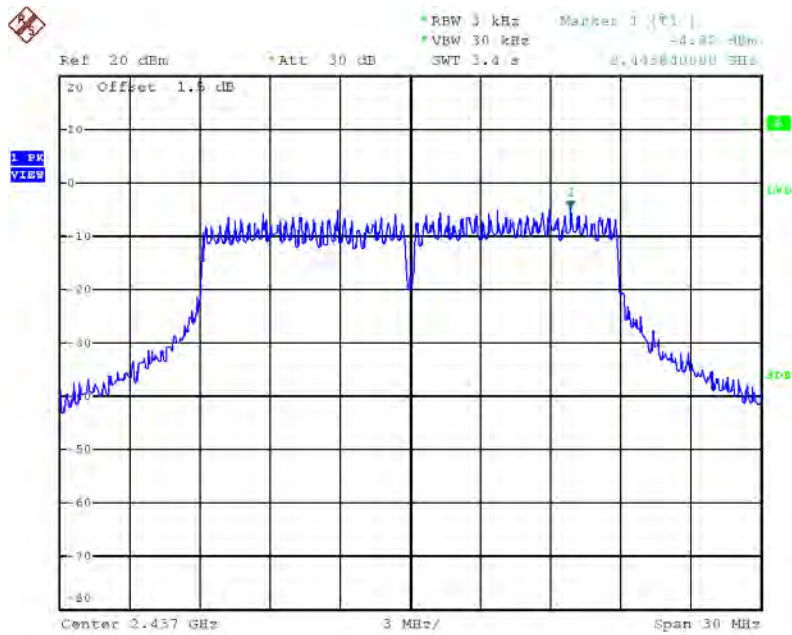

Date: 20.SEP.2013 12:41:24

Power Density Plot on Configuration IEEE 802.11n MCS0 20MHz / 2437 MHz / 2TX / Chain 2

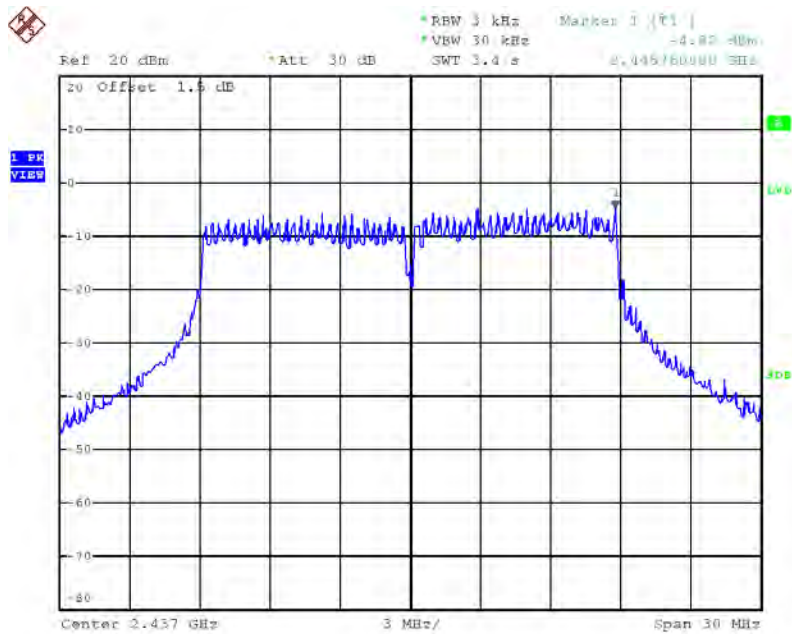

Date: 20.SEP.2013 12:40:36

Power Density Plot on Configuration IEEE 802.11n MCS0 40MHz / 2437 MHz / 2TX / Chain 1

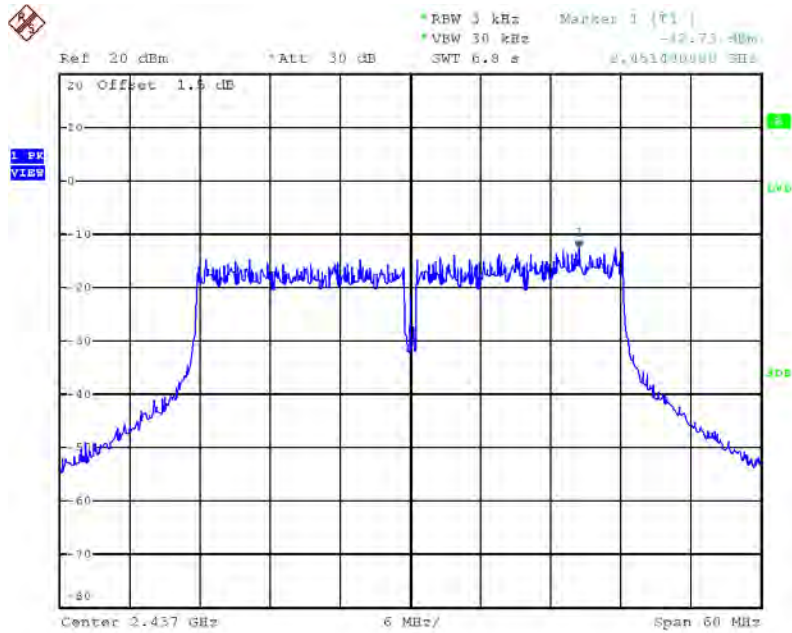

Date: 20.SEP.2013 12:46:23

Power Density Plot on Configuration IEEE 802.11n MCS0 40MHz / 2437 MHz / 2TX / Chain 2

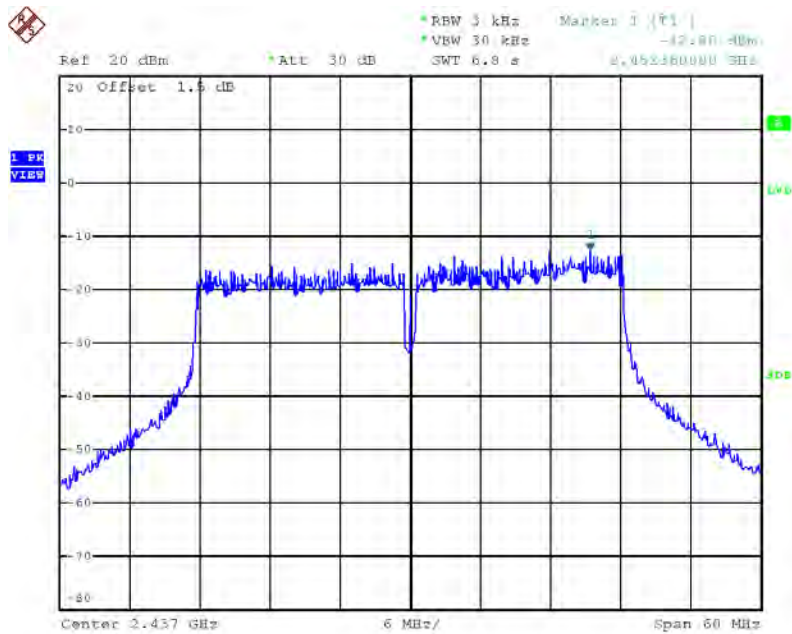

Date: 20.SEP.2013 12:47:09

Power Density Plot on Configuration IEEE 802.11n MCS0 20MHz / 2437 MHz / 3TX / Chain 1

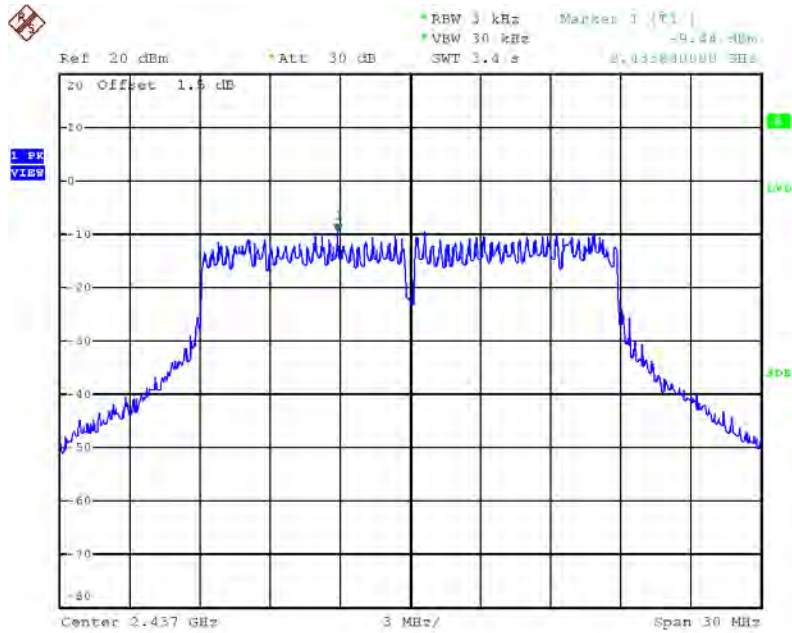

Date: 20.SEP.2013 13:23:07

Power Density Plot on Configuration IEEE 802.11n MCS0 20MHz / 2437 MHz / 3TX / Chain 2

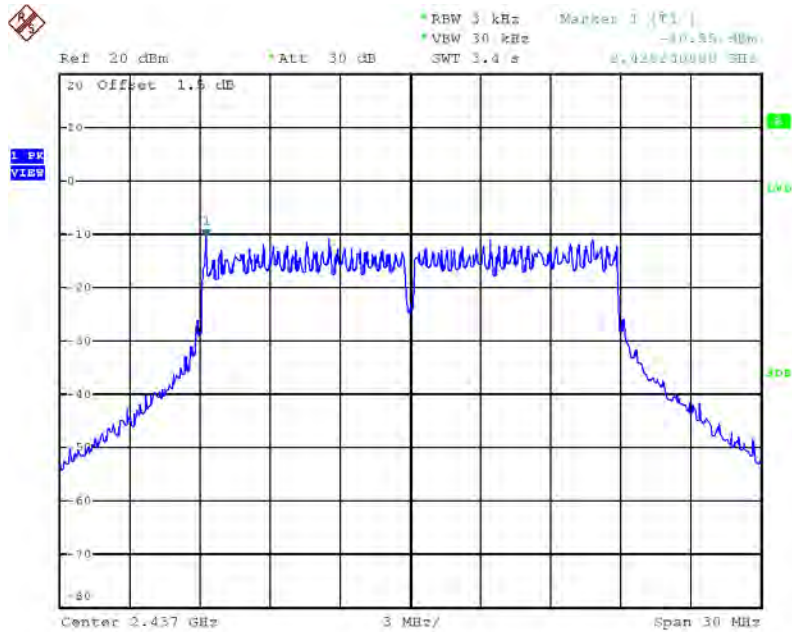

Date: 20.SEP.2013 13:22:25

Power Density Plot on Configuration IEEE 802.11n MCS0 20MHz / 2437 MHz / 3TX / Chain 3

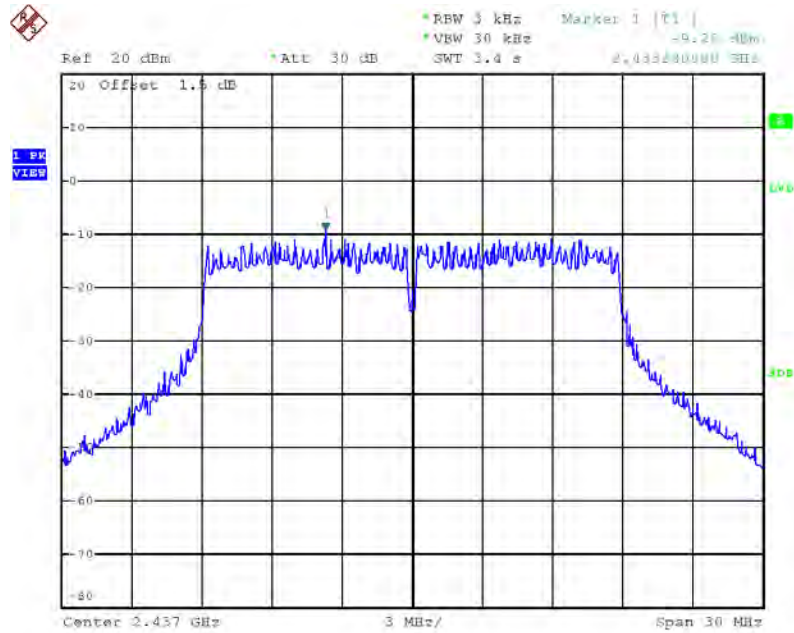

Date: 20 SEP 2013 13:21:47

Power Density Plot on Configuration IEEE 802.11n MCS0 40MHz / 2437 MHz / 3TX / Chain 1

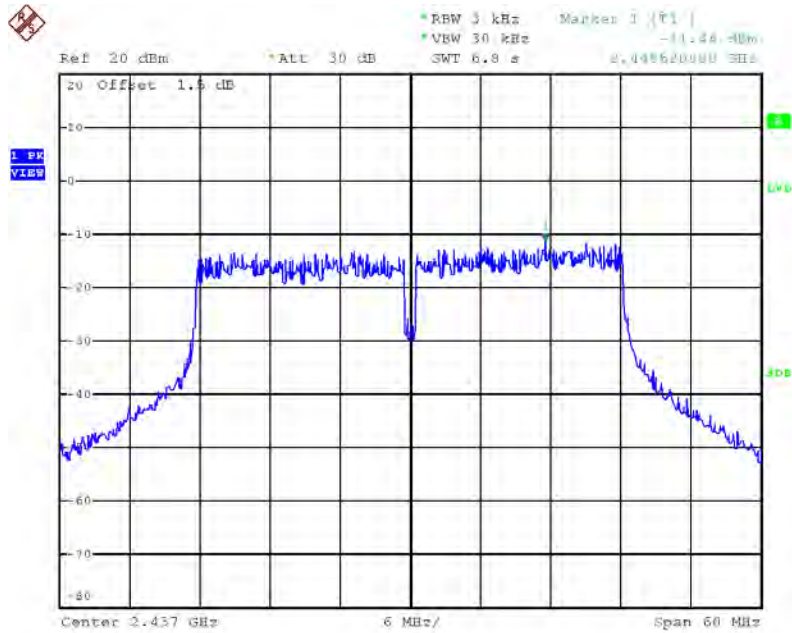

Date: 20.SEP.2013 13:28:57

Power Density Plot on Configuration IEEE 802.11n MCS0 40MHz / 2437 MHz / 3TX / Chain 2

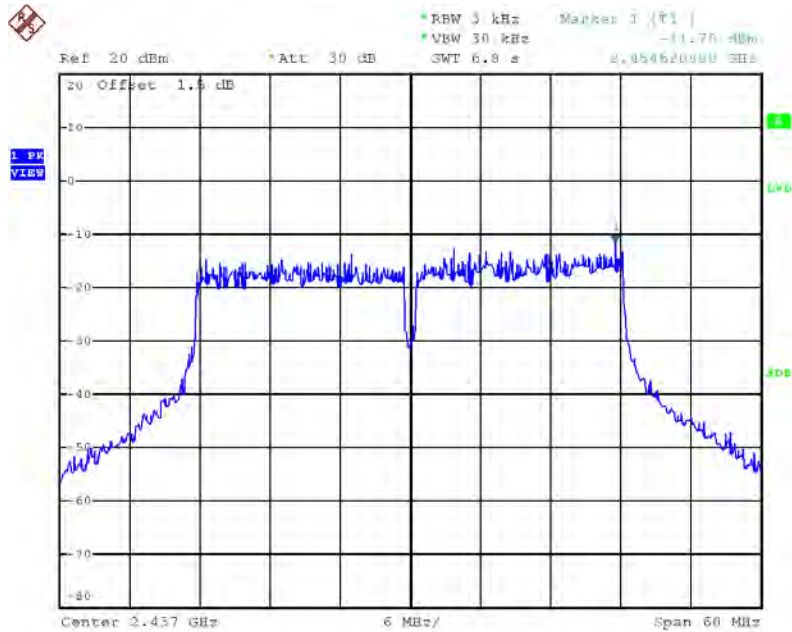

Date: 20.SEP.2013 13:29:35

Power Density Plot on Configuration IEEE 802.11n MCS0 40MHz / 2437 MHz / 3TX / Chain 3

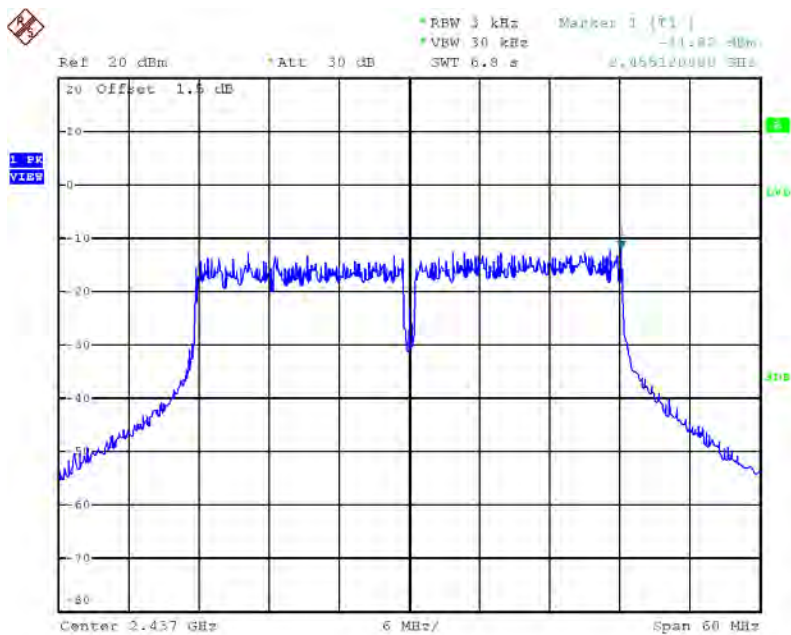

Date: 20.SEP.2013 13:30:38

Power Density Plot on Configuration IEEE 802.11n MCS8 20MHz / 2437 MHz / 2TX / Chain 1

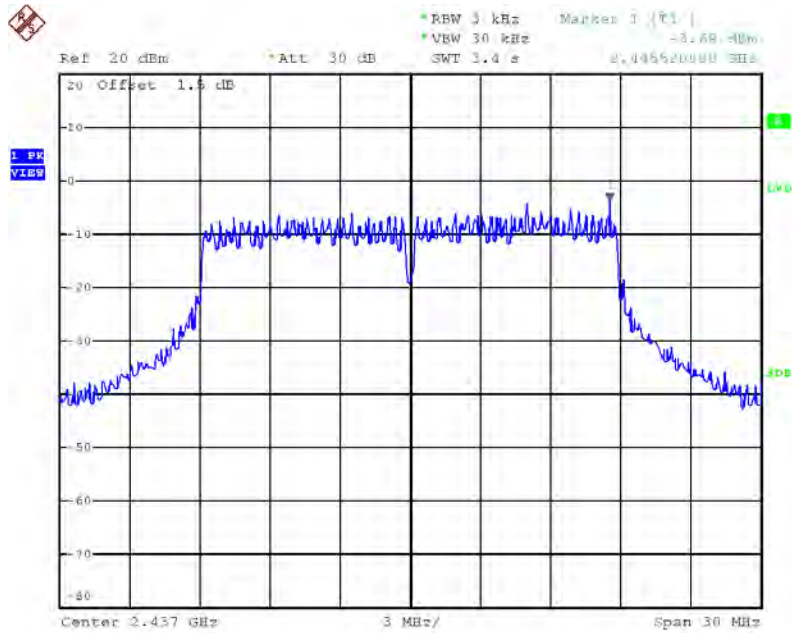

Date: 20.SEP.2013 12:58:21

Power Density Plot on Configuration IEEE 802.11n MCS8 20MHz / 2437 MHz / 2TX / Chain 2

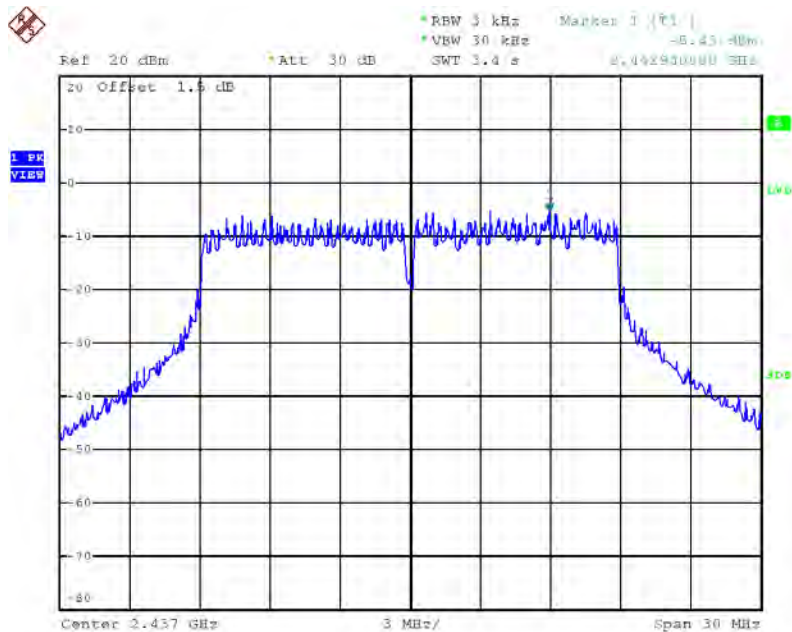

Date: 20.SEP.2013 12:59:10

Power Density Plot on Configuration IEEE 802.11n MCS8 40MHz / 2437 MHz / 2TX / Chain 1

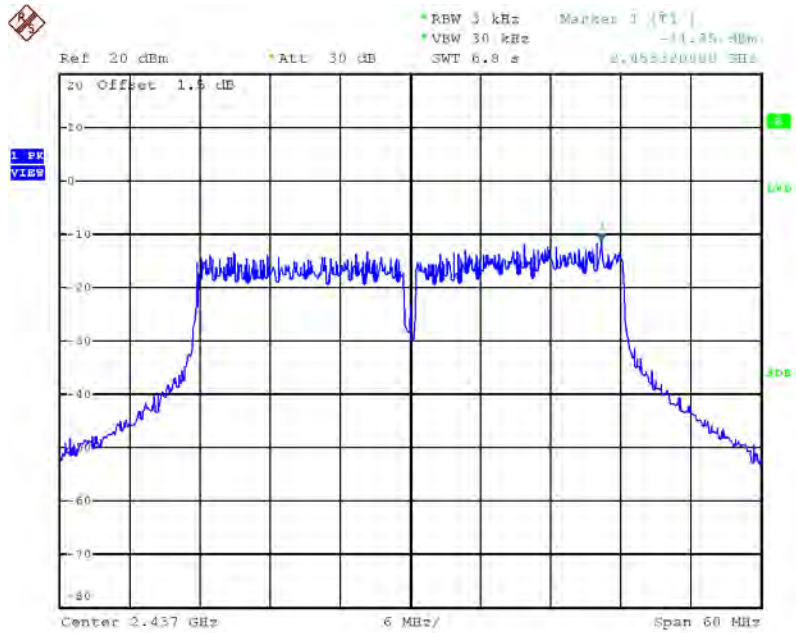

Date: 20 SEP 2013 12:54:22

Power Density Plot on Configuration IEEE 802.11n MCS8 40MHz / 2437 MHz / 2TX / Chain 2

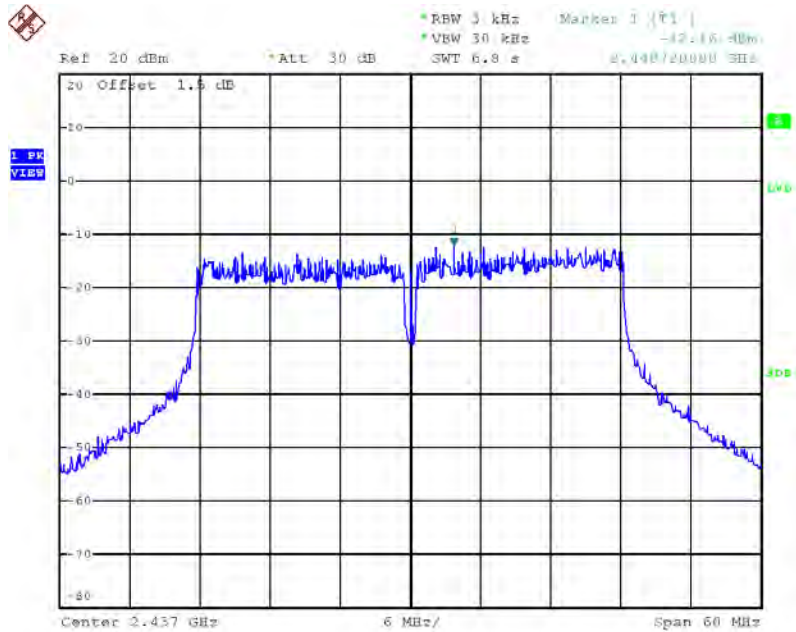

Date: 20 SEP 2013 12:53:24

Power Density Plot on Configuration IEEE 802.11n MCS8 20MHz / 2412 MHz / 3TX / Chain 1

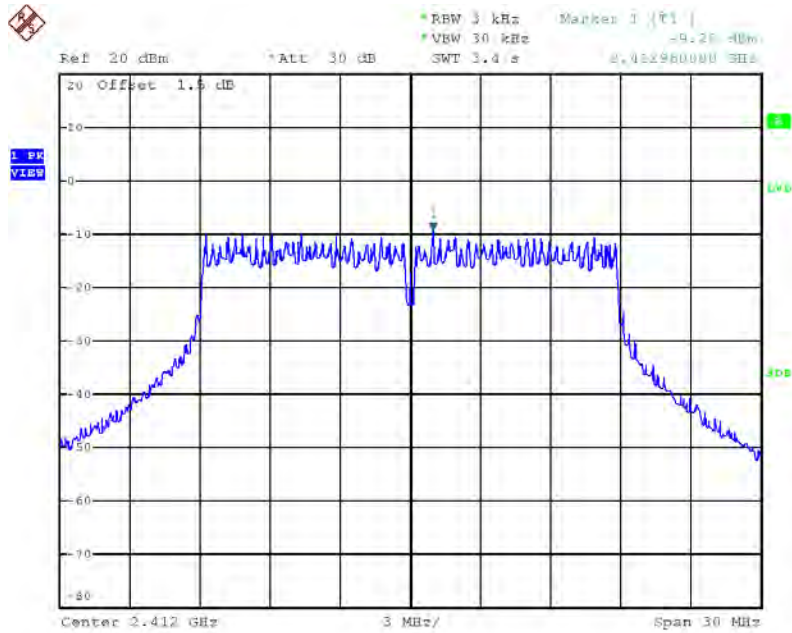

Date: 20.SEP.2013 13:38:02

Power Density Plot on Configuration IEEE 802.11n MCS8 20MHz / 2412 MHz / 3TX / Chain 2

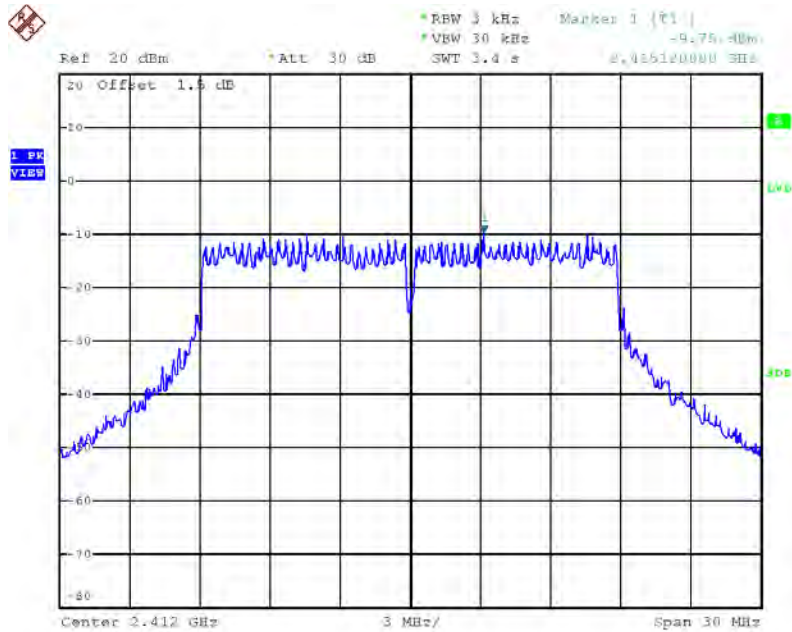

Date: 20.SEP.2013 13:38:50

Power Density Plot on Configuration IEEE 802.11n MCS8 20MHz / 2412 MHz / 3TX / Chain 3

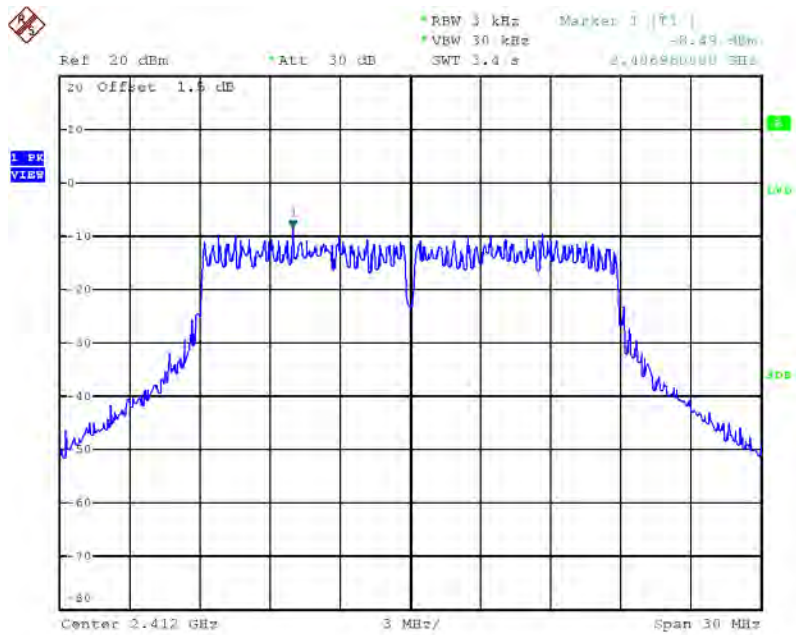

Date: 20.SEP.2013 13:39:31

Power Density Plot on Configuration IEEE 802.11n MCS8 40MHz / 2437 MHz / 3TX / Chain 1

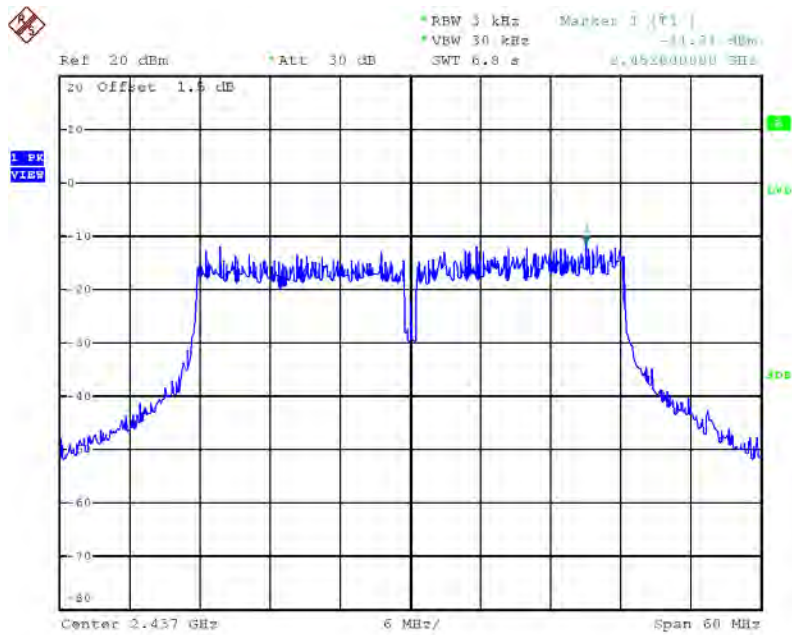

Date: 20.SEP.2013 13:47:31

Power Density Plot on Configuration IEEE 802.11n MCS8 40MHz / 2437 MHz / 3TX / Chain 2

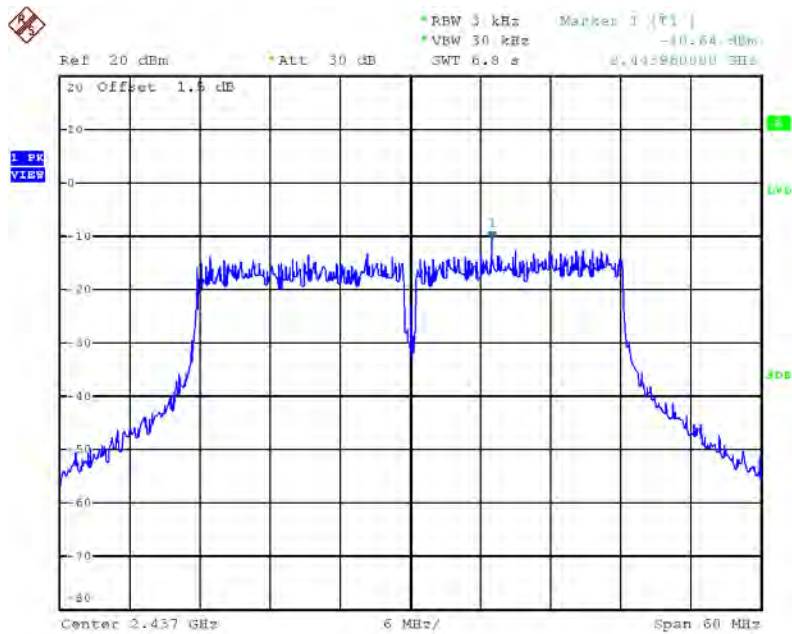

Date: 20.SEP.2013 13:48:14

Power Density Plot on Configuration IEEE 802.11n MCS8 40MHz / 2437 MHz / 3TX / Chain 3

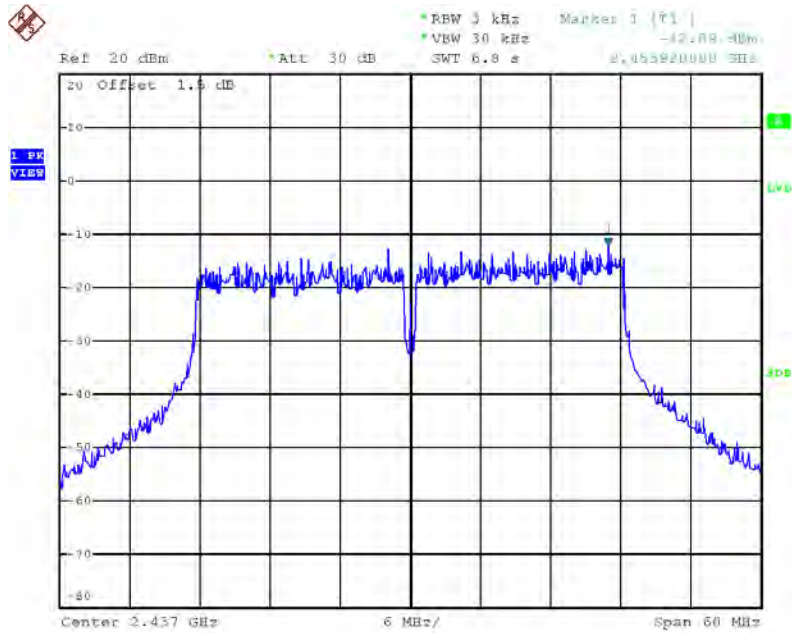

Date: 20.SEP.2013 13:48:56

Power Density Plot on Configuration IEEE 802.11n MCS16 20MHz / 2412 MHz / 3TX / Chain 1

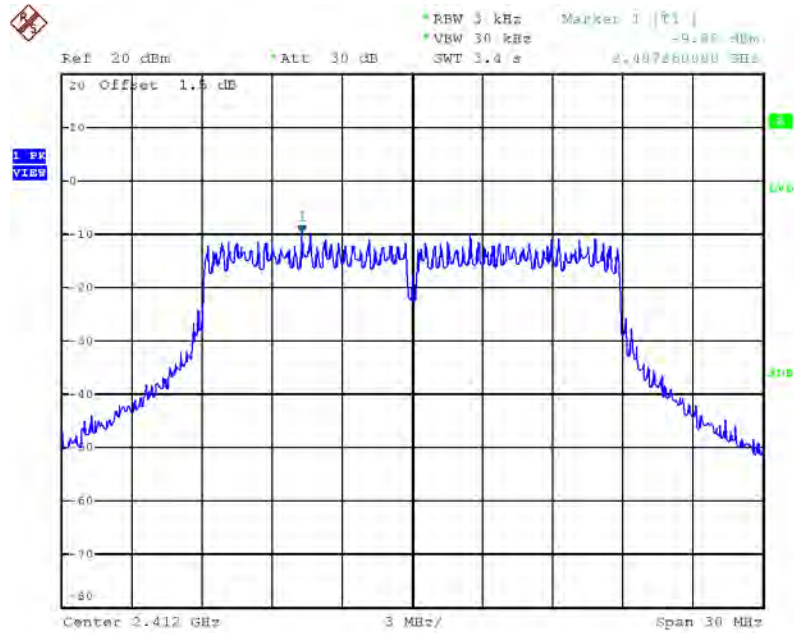

Date: 20.SEP.2013 13:54:09

Power Density Plot on Configuration IEEE 802.11n MCS16 20MHz / 2412 MHz / 3TX / Chain 2

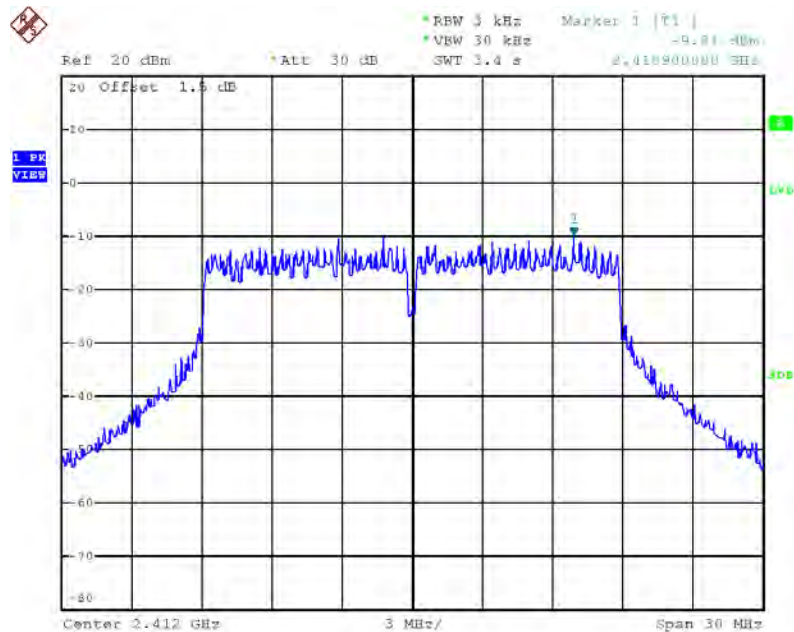

Date: 20.SEP.2013 13:53:21

Power Density Plot on Configuration IEEE 802.11n MCS16 20MHz / 2412 MHz / 3TX / Chain 3

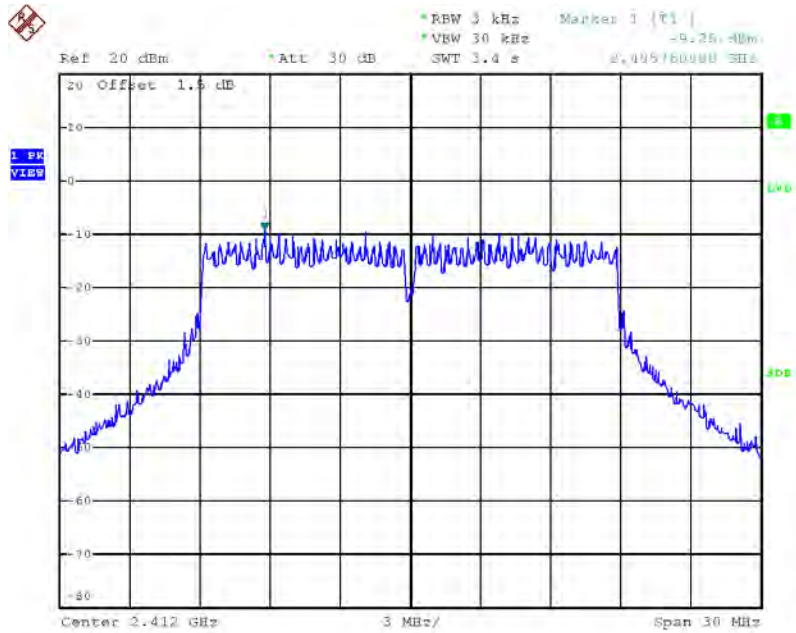

Date: 20 SEP 2013 13:52:44

Power Density Plot on Configuration IEEE 802.11n MCS16 40MHz / 2437 MHz / 3TX / Chain 1

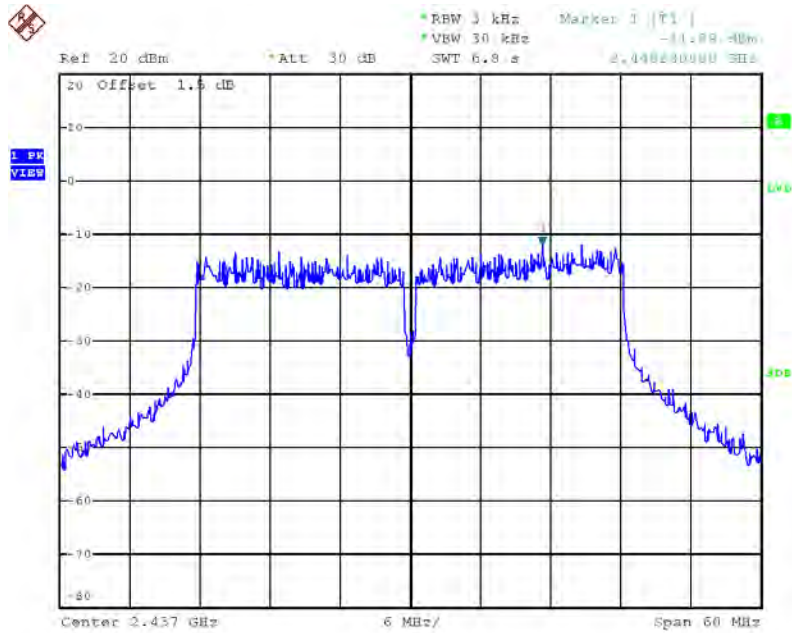

Date: 20-SEP-2013 14:03:23

Power Density Plot on Configuration IEEE 802.11n MCS16 40MHz / 2437 MHz / 3TX / Chain 2

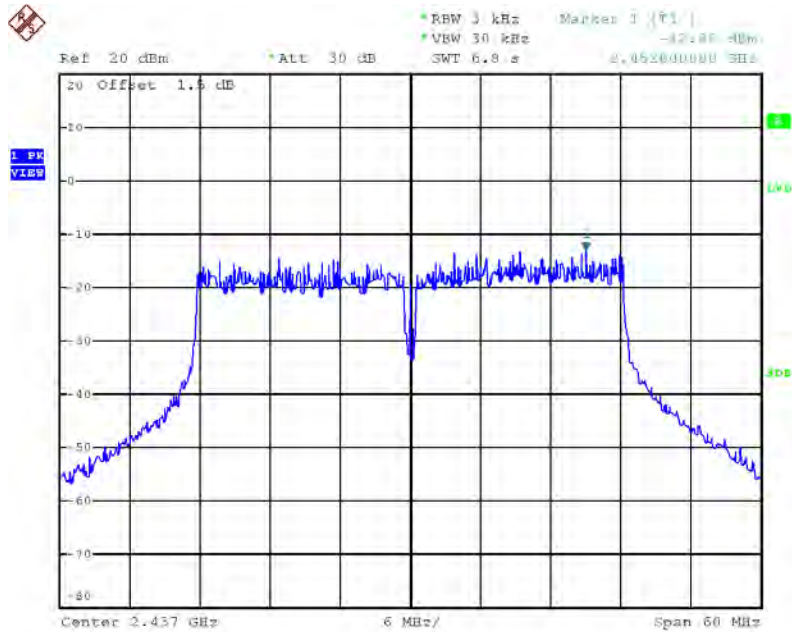

Date: 20-SEP-2013 14:02:43

Power Density Plot on Configuration IEEE 802.11n MCS16 40MHz / 2437 MHz / 3TX / Chain 3

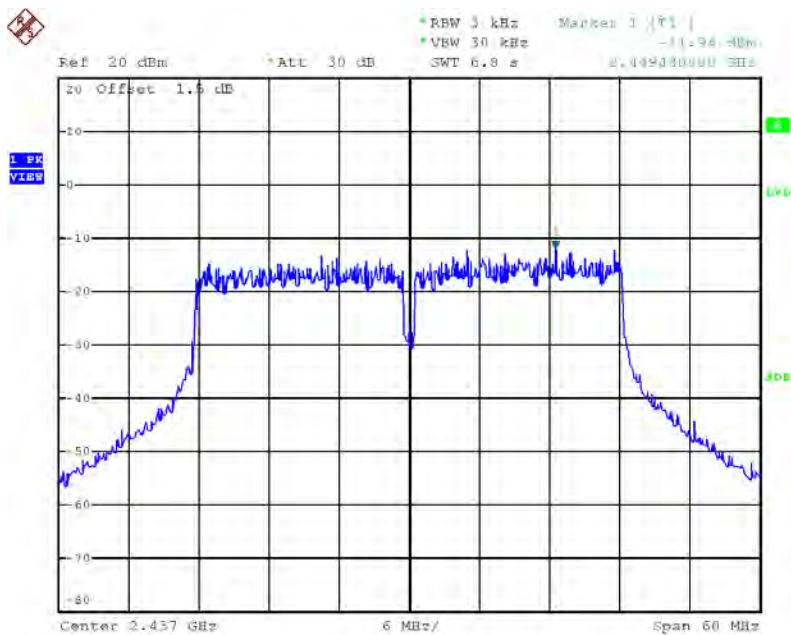

Date: 20 SEP 2013 14:02:06

Power Density Plot on Configuration IEEE 802.11b / 2437 MHz / 1TX / Chain 1



Date: 20.SEP.2013 12:09:44

Power Density Plot on Configuration IEEE 802.11b / 2437 MHz / 2TX / Chain 1



Date: 20.SEP-2013 12:31:00

Power Density Plot on Configuration IEEE 802.11b / 2437 MHz / 2TX / Chain 2

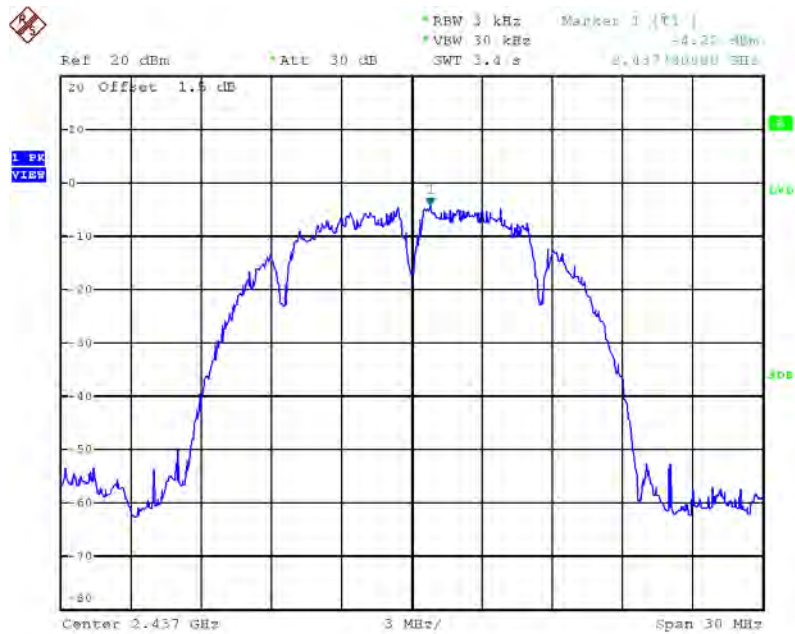

Date: 20.SEP-2013 12:30:13

Power Density Plot on Configuration IEEE 802.11b / 2437 MHz / 3TX / Chain 1



Date: 20.SEP.2013 13:09:48

Power Density Plot on Configuration IEEE 802.11b / 2437 MHz / 3TX / Chain 2

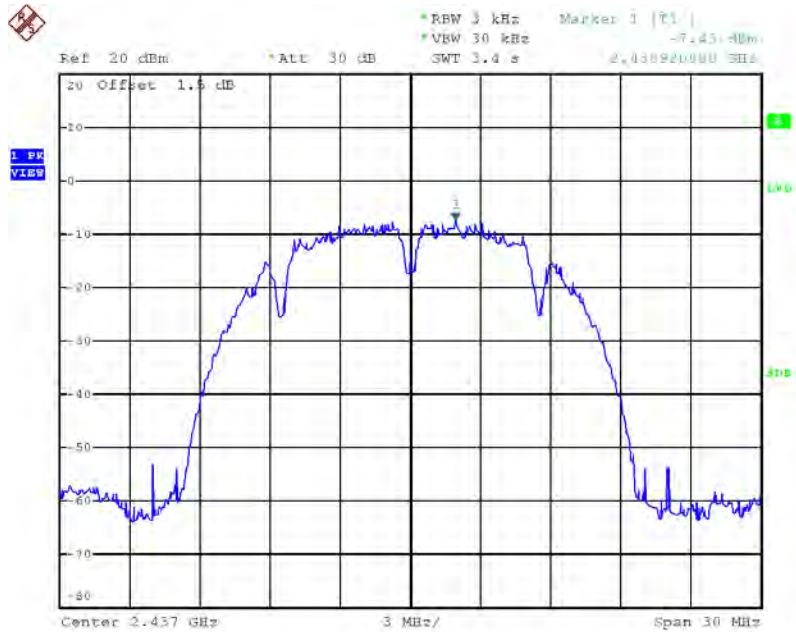

Date: 20.SEP.2013 13:09:11

Power Density Plot on Configuration IEEE 802.11b / 2437 MHz / 3TX / Chain 3

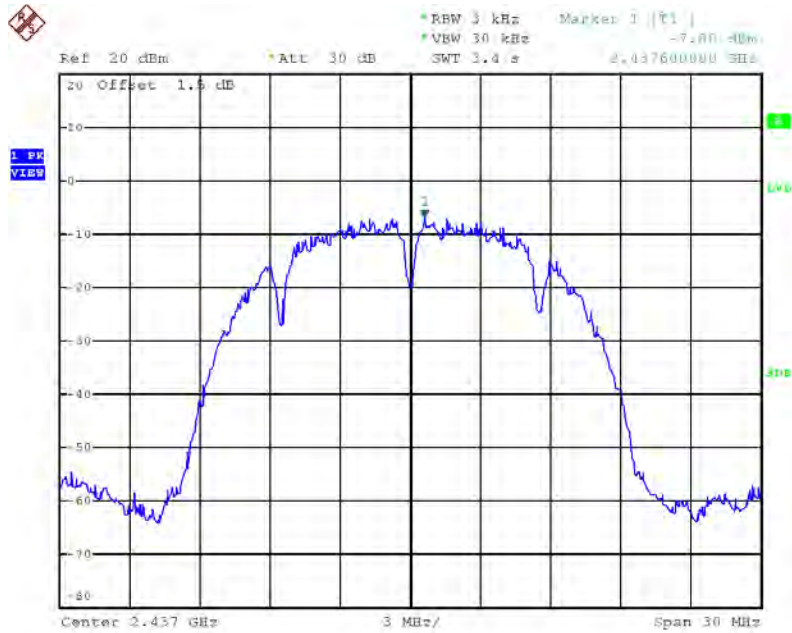

Date: 20.SEP.2013 13:08:06

Power Density Plot on Configuration IEEE 802.11g / 2437 MHz / 1TX / Chain 1

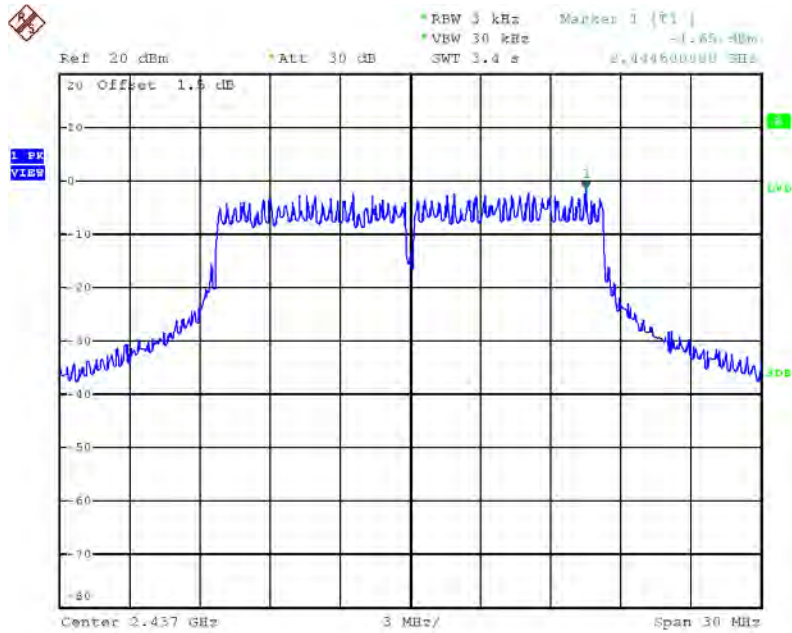

Date: 20.SEP.2013 12:12:50

Power Density Plot on Configuration IEEE 802.11g / 2437 MHz / 2TX / Chain 1

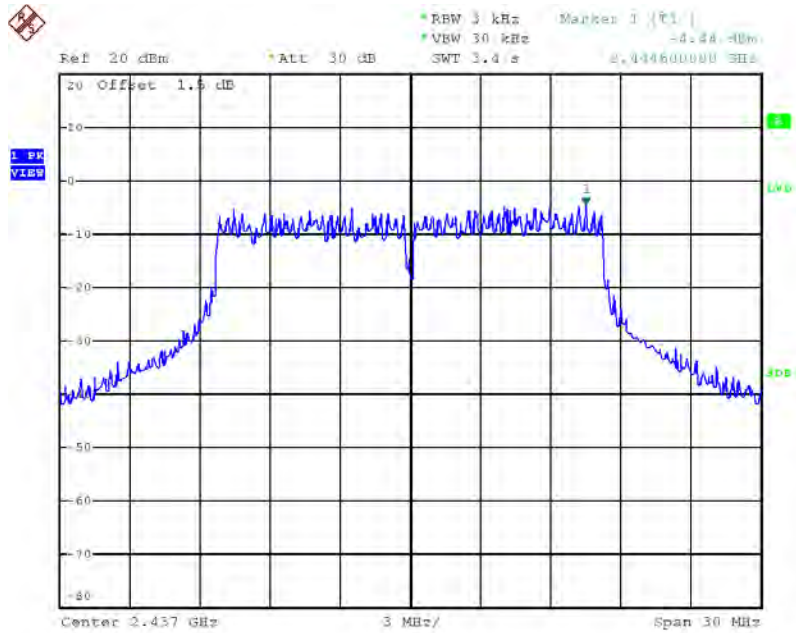

Date: 20.SEP.2013 12:35:14

Power Density Plot on Configuration IEEE 802.11g / 2437 MHz / 2TX / Chain 2

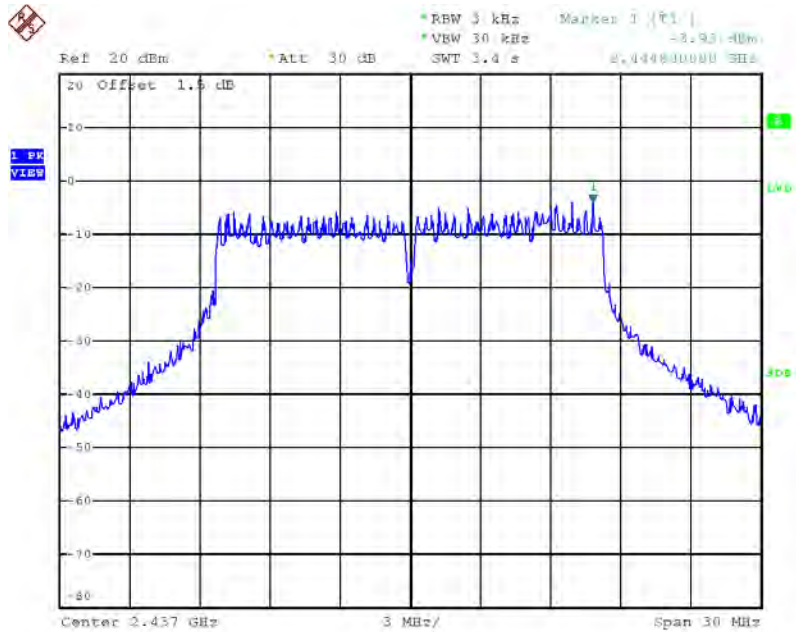

Date: 20.SEP.2013 12:35:59

Power Density Plot on Configuration IEEE 802.11g / 2412 MHz / 3TX / Chain 1

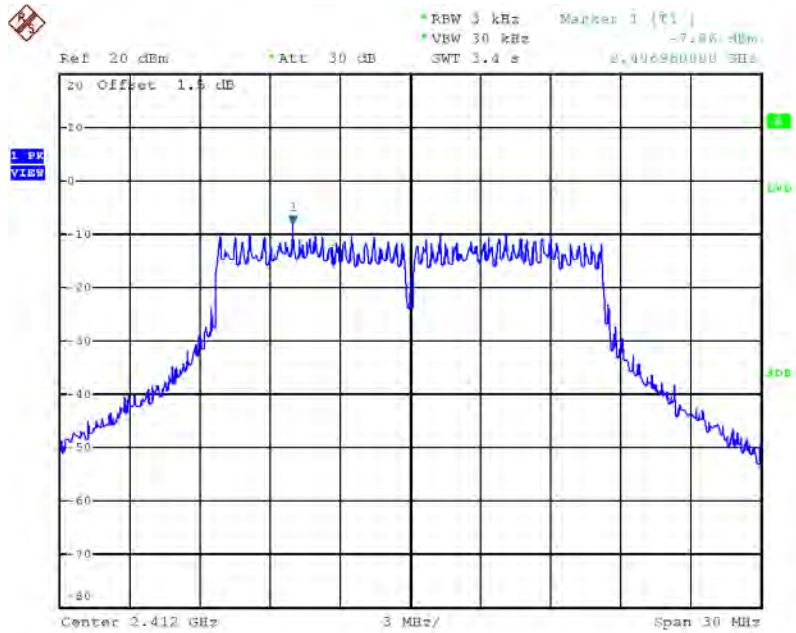

Date: 20.SEP.2013 13:14:28

Power Density Plot on Configuration IEEE 802.11g / 2412 MHz / 3TX / Chain 2

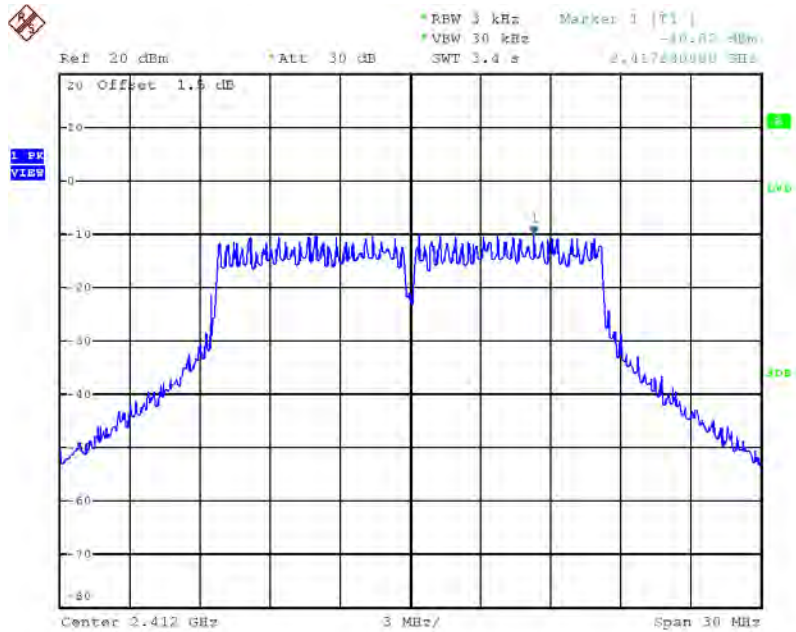

Date: 20.SEP.2013 13:13:42

Power Density Plot on Configuration IEEE 802.11g / 2412 MHz / 3TX / Chain 3

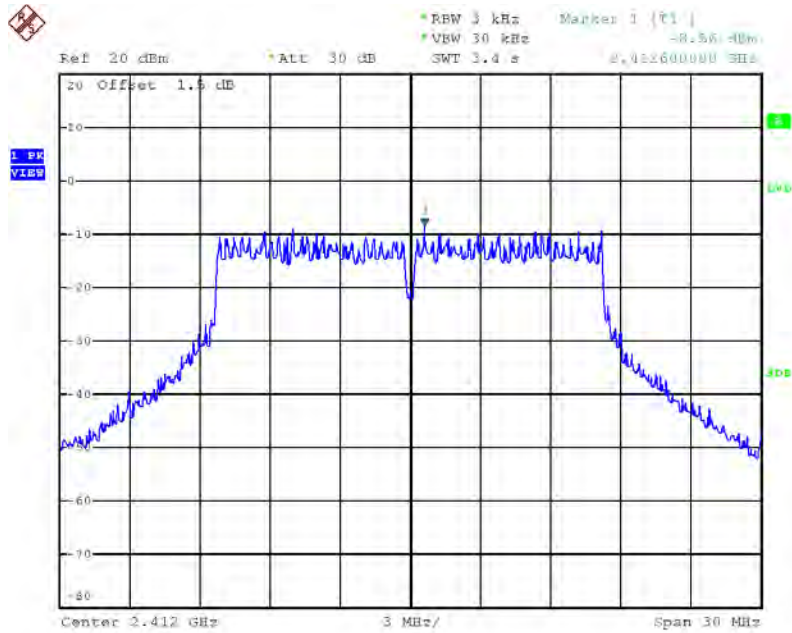

Date: 20.SEP.2013 13:12:56

For 5GHz Band

Power Density Plot on Configuration IEEE 802.11n MCS0 20MHz / 5825 MHz / Chain 1

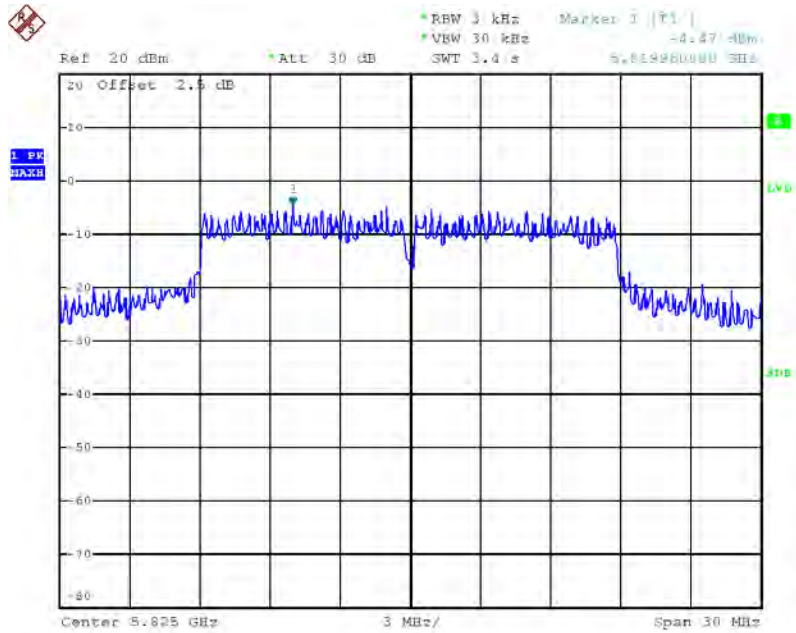

Date: 16.SEP.2013 16:03:12

Power Density Plot on Configuration IEEE 802.11n MCS0 40MHz / 5795 MHz / Chain 1

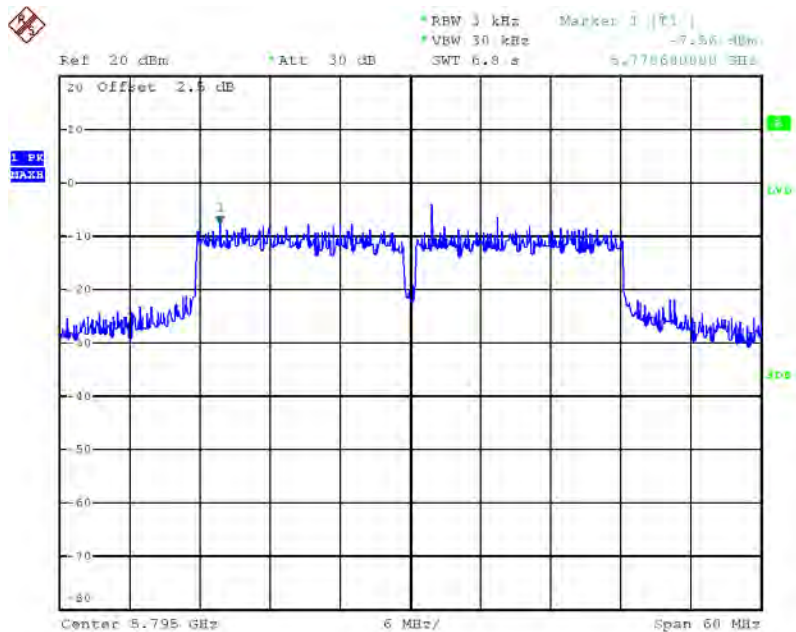

Date: 16.SEP.2013 16:06:56

Power Density Plot on Configuration IEEE 802.11n MCS8 20MHz / 5745 MHz / 2TX / Chain 1

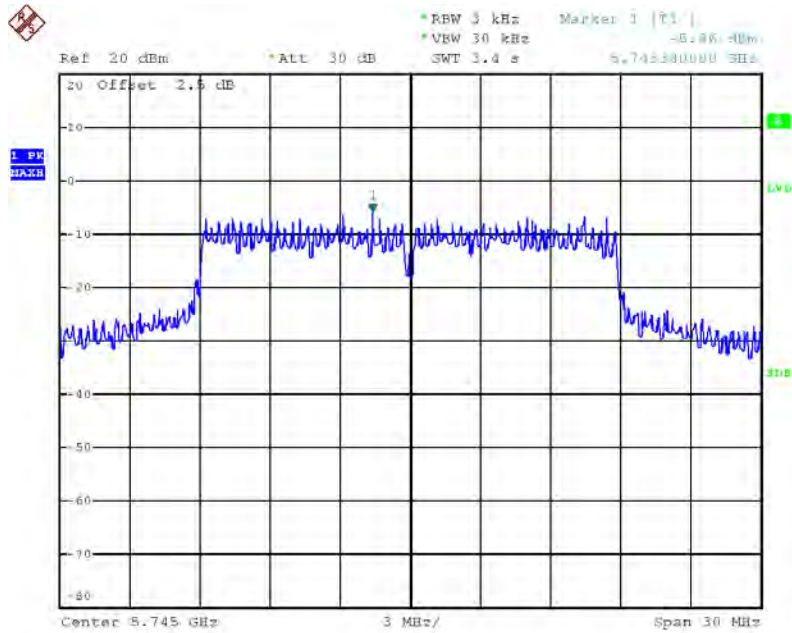

Date: 16.SEP.2013 16:09:21

Power Density Plot on Configuration IEEE 802.11n MCS8 20MHz / 5745 MHz / 2TX / Chain 2

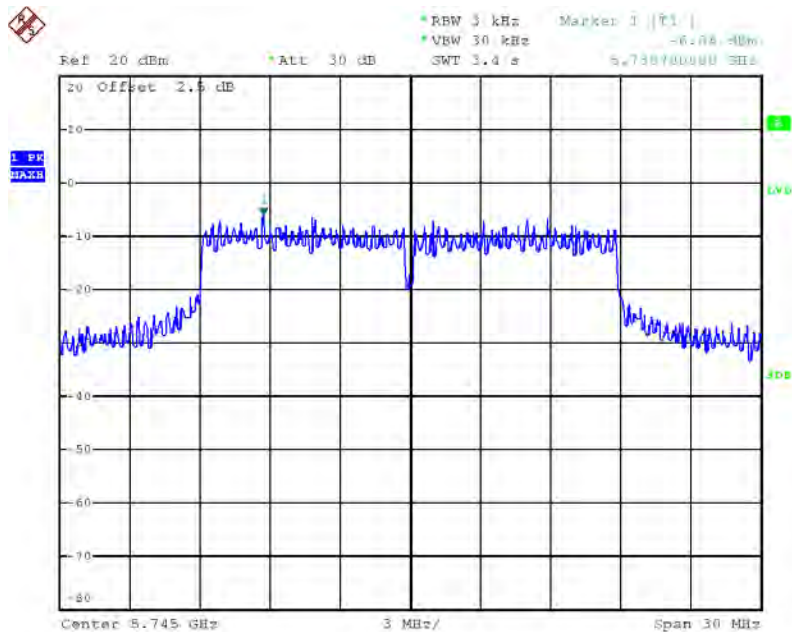

Date: 16.SEP.2013 16:10:20

Power Density Plot on Configuration IEEE 802.11n MCS8 40MHz / 5755 MHz / 2TX / Chain 1

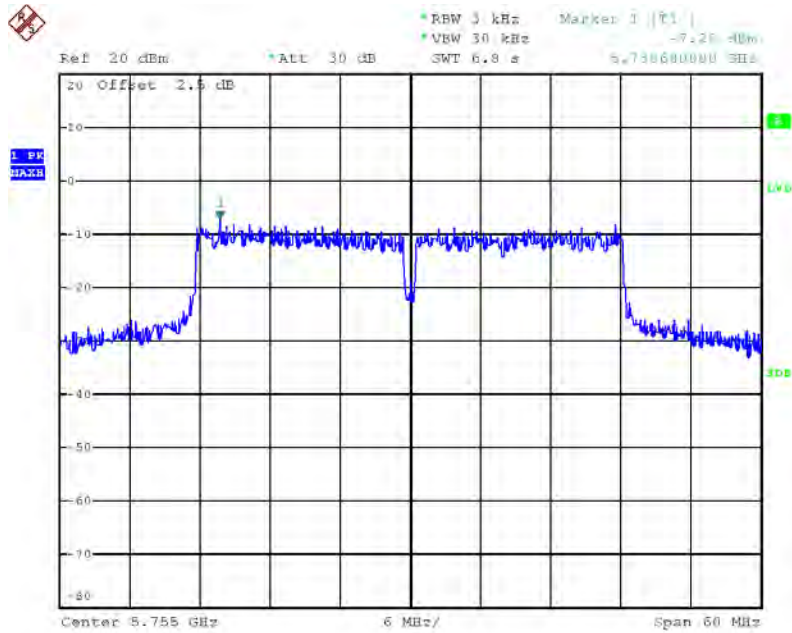

Date: 16.SEP.2013 16:30:11

Power Density Plot on Configuration IEEE 802.11n MCS8 40MHz / 5755 MHz / 2TX / Chain 2

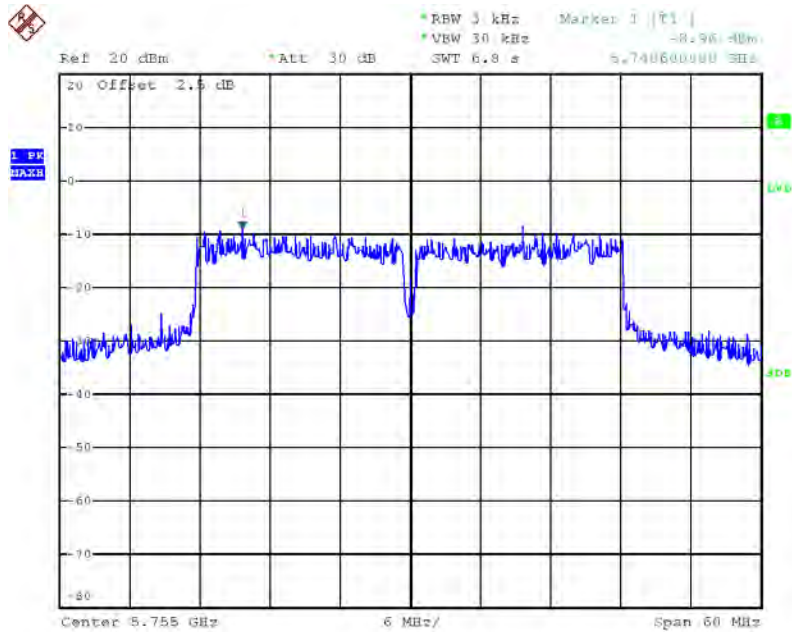

Date: 16.SEP.2013 16:31:00

Power Density Plot on Configuration IEEE 802.11n MCS16 20MHz / 5745 MHz / 3TX / Chain 1

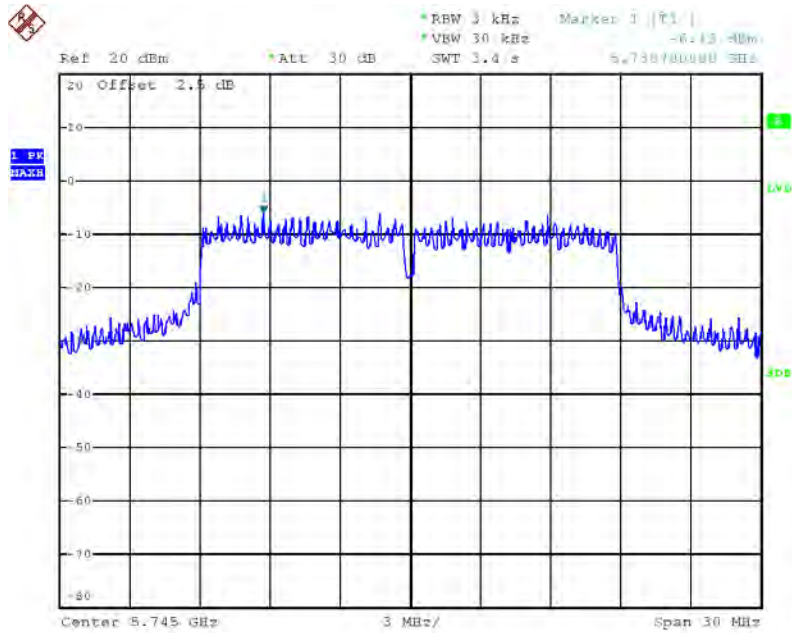

Date: 16.SEP.2013 16:36:56

Power Density Plot on Configuration IEEE 802.11n MCS16 20MHz / 5745 MHz / 3TX / Chain 2

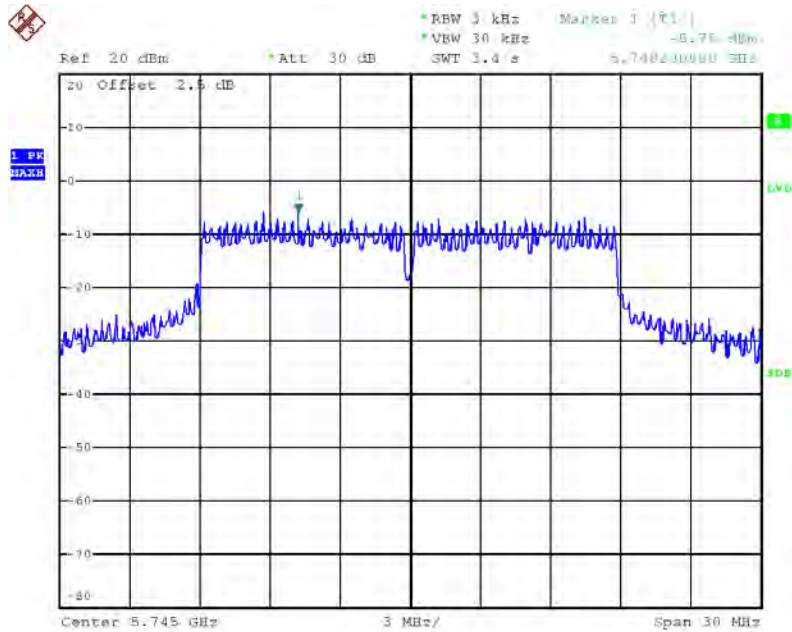

Date: 16.SEP.2013 16:37:32

Power Density Plot on Configuration IEEE 802.11n MCS16 20MHz / 5745 MHz / 3TX / Chain 3

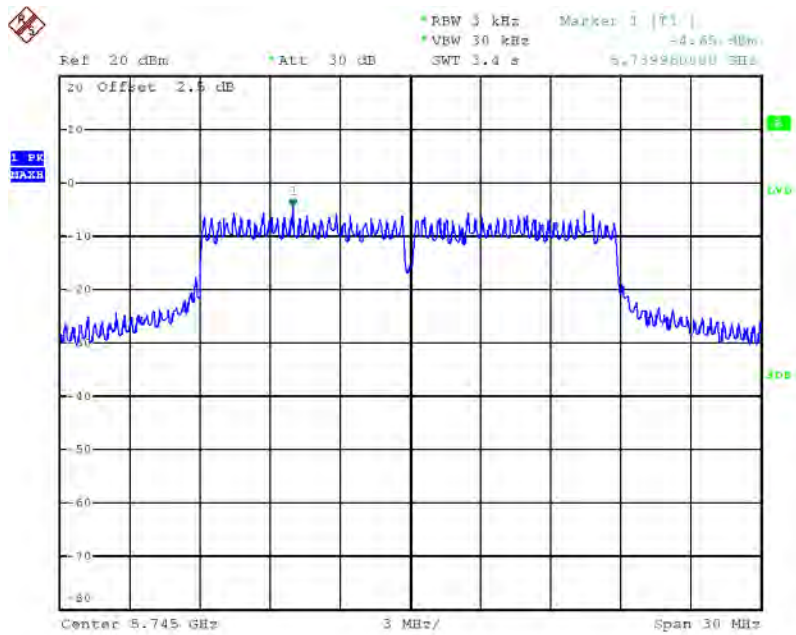

Date: 18.SEP.2013 16:43:56

Power Density Plot on Configuration IEEE 802.11n MCS16 40MHz / 5755 MHz / 3TX / Chain 1

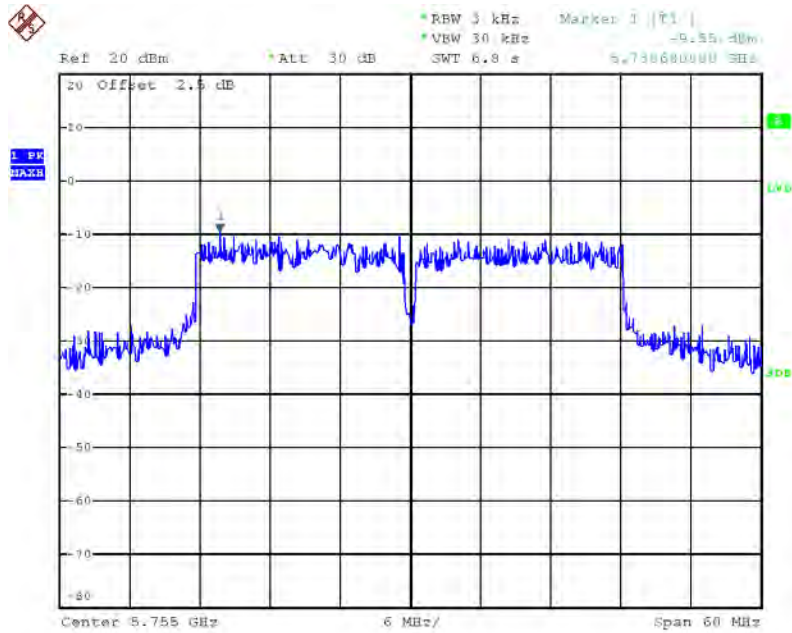

Date: 16.SEP.2013 16:51:57

Power Density Plot on Configuration IEEE 802.11n MCS16 40MHz / 5755 MHz / 3TX / Chain 2

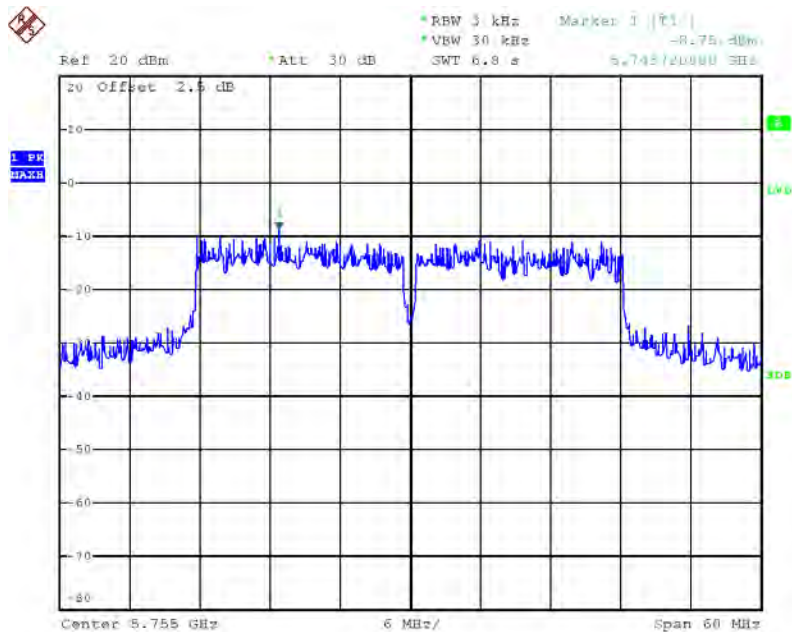

Date: 16.SEP.2013 16:52:39

Power Density Plot on Configuration IEEE 802.11n MCS16 40MHz / 5755 MHz / 3TX / Chain 3

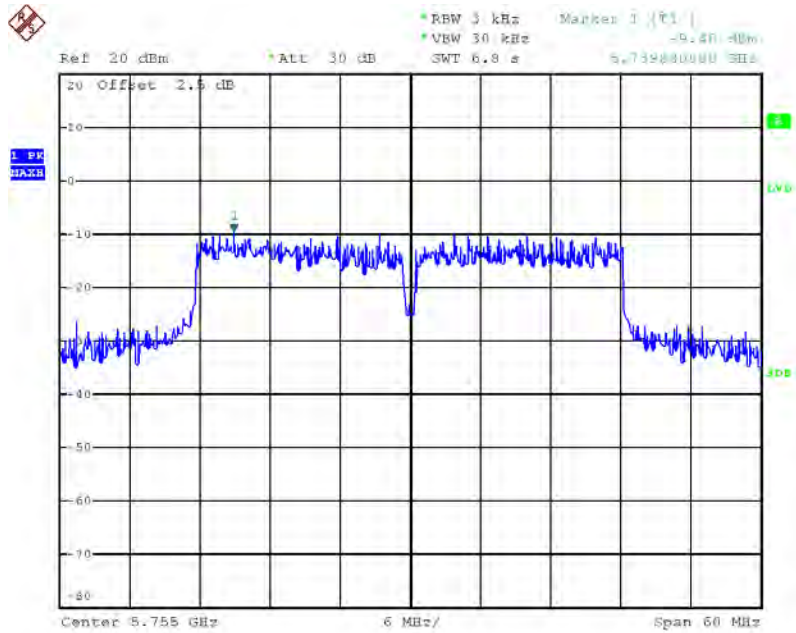

Date: 18.SEP.2013 18:53:15

Power Density Plot on Configuration IEEE 802.11a / 5745 MHz / Chain 1

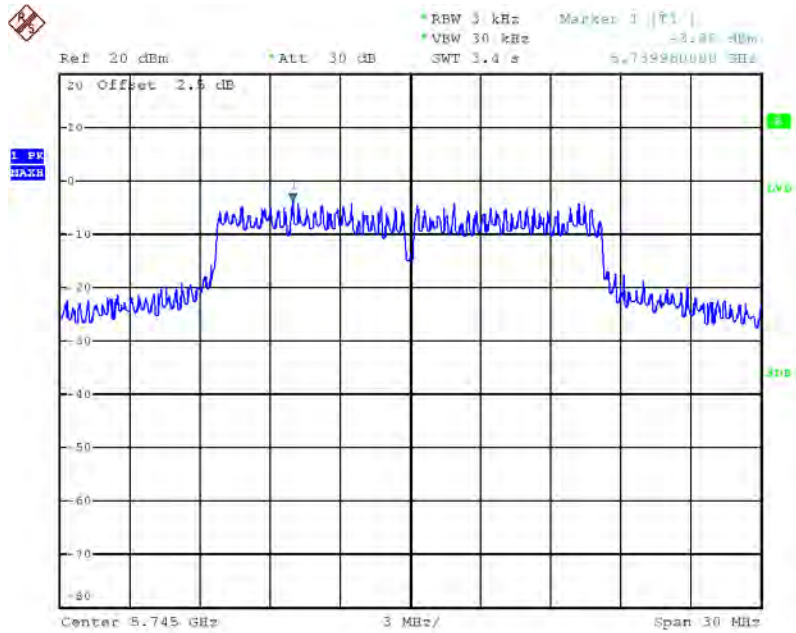

Date: 18.SEP.2013 16:01:18

4.3. 6dB Spectrum Bandwidth Measurement

4.3.1. Limit

For digital modulation systems, the minimum 6dB bandwidth shall be at least 500 kHz.

4.3.2. Measuring Instruments and Setting

Please refer to section 5 of equipments list in this report. The following table is the setting of the spectrum analyzer.

Spectrum Parameters	Setting
Attenuation	Auto
Span Frequency	> 6dB Bandwidth
RBW	100kHz
VBW	$\geq 3 \times \text{RBW}$
Detector	Peak
Trace	Max Hold
Sweep Time	Auto

4.3.3. Test Procedures

1. The transmitter output (antenna port) was connected to the spectrum analyzer in peak hold mode.
2. Test was performed in accordance with KDB 558074 D01 v03r01 for Performing Compliance Measurements on Digital Transmission Systems (DTS) Operating Under §15.247 section 8.0 DTS 6-dB signal bandwidth option 1.
3. Multiple antenna system was performed in accordance with KDB 662911 D01 v02 Emissions Testing of Transmitters with Multiple Outputs in the Same Band.
4. Measured the spectrum width with power higher than 6dB below carrier.

4.3.4. Test Setup Layout

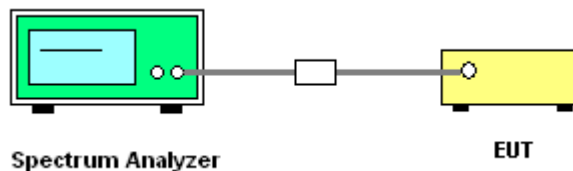

4.3.5. Test Deviation

There is no deviation with the original standard.

4.3.6. EUT Operation during Test

The EUT was programmed to be in continuously transmitting mode.

4.3.7. Test Result of 6dB Spectrum Bandwidth

Temperature	24°C	Humidity	61%
Test Engineer	Kenneth Huang	Configurations	IEEE 802.11b/g/n
Test Mode	Mode 1 (Ant.31 PIFA antenna / 4.4dBi)		

For 2.4GHz Band

Configuration IEEE 802.11n MCS0 20MHz / Chain 1

Channel	Frequency	6dB Bandwidth (MHz)	99% Occupied Bandwidth (MHz)	Min. Limit (kHz)	Test Result
1	2412 MHz	17.60	17.76	500	Complies
6	2437 MHz	17.60	17.84	500	Complies
11	2462 MHz	17.60	17.76	500	Complies

Configuration IEEE 802.11n MCS0 40MHz / Chain 1

Channel	Frequency	6dB Bandwidth (MHz)	99% Occupied Bandwidth (MHz)	Min. Limit (kHz)	Test Result
3	2422 MHz	36.48	36.48	500	Complies
6	2437 MHz	35.84	36.32	500	Complies
9	2452 MHz	35.84	36.32	500	Complies

Configuration IEEE 802.11n MCS0 20MHz / Chain 1 + Chain 2

Channel	Frequency	6dB Bandwidth (MHz)	99% Occupied Bandwidth (MHz)	Min. Limit (kHz)	Test Result
1	2412 MHz	17.68	17.92	500	Complies
6	2437 MHz	17.60	17.92	500	Complies
11	2462 MHz	17.60	17.92	500	Complies

Configuration IEEE 802.11n MCS0 40MHz / Chain 1 + Chain 2

Channel	Frequency	6dB Bandwidth (MHz)	99% Occupied Bandwidth (MHz)	Min. Limit (kHz)	Test Result
3	2422 MHz	36.48	36.64	500	Complies
6	2437 MHz	36.00	36.00	500	Complies
9	2452 MHz	36.32	36.48	500	Complies

Configuration IEEE 802.11n MCS0 20MHz / Chain 1 + Chain 2 + Chain 3

Channel	Frequency	6dB Bandwidth (MHz)	99% Occupied Bandwidth (MHz)	Min. Limit (kHz)	Test Result
1	2412 MHz	16.32	17.60	500	Complies
6	2437 MHz	16.56	17.60	500	Complies
11	2462 MHz	16.32	17.92	500	Complies

Configuration IEEE 802.11n MCS0 40MHz / Chain 1 + Chain 2 + Chain 3

Channel	Frequency	6dB Bandwidth (MHz)	99% Occupied Bandwidth (MHz)	Min. Limit (kHz)	Test Result
3	2422 MHz	33.92	35.36	500	Complies
6	2437 MHz	30.88	36.48	500	Complies
9	2452 MHz	32.64	35.36	500	Complies

Configuration IEEE 802.11n MCS8 20MHz / Chain 1 + Chain 2

Channel	Frequency	6dB Bandwidth (MHz)	99% Occupied Bandwidth (MHz)	Min. Limit (kHz)	Test Result
1	2412 MHz	15.76	17.60	500	Complies
6	2437 MHz	14.48	17.68	500	Complies
11	2462 MHz	16.24	17.68	500	Complies

Configuration IEEE 802.11n MCS8 40MHz / Chain 1 + Chain 2

Channel	Frequency	6dB Bandwidth (MHz)	99% Occupied Bandwidth (MHz)	Min. Limit (kHz)	Test Result
3	2422 MHz	36.16	36.64	500	Complies
6	2437 MHz	35.84	36.32	500	Complies
9	2452 MHz	33.92	36.32	500	Complies

Configuration IEEE 802.11n MCS8 20MHz / Chain 1 + Chain 2 + Chain 3

Channel	Frequency	6dB Bandwidth (MHz)	99% Occupied Bandwidth (MHz)	Min. Limit (kHz)	Test Result
1	2412 MHz	16.72	17.60	500	Complies
6	2437 MHz	16.32	17.76	500	Complies
11	2462 MHz	12.56	17.68	500	Complies

Configuration IEEE 802.11n MCS8 40MHz / Chain 1 + Chain 2 + Chain 3

Channel	Frequency	6dB Bandwidth (MHz)	99% Occupied Bandwidth (MHz)	Min. Limit (kHz)	Test Result
3	2422 MHz	34.56	36.32	500	Complies
6	2437 MHz	32.64	36.16	500	Complies
9	2452 MHz	35.84	36.32	500	Complies

Configuration IEEE 802.11n MCS16 20MHz / Chain 1 + Chain 2 + Chain 3

Channel	Frequency	6dB Bandwidth (MHz)	99% Occupied Bandwidth (MHz)	Min. Limit (kHz)	Test Result
1	2412 MHz	17.60	17.68	500	Complies
6	2437 MHz	17.68	17.68	500	Complies
11	2462 MHz	17.04	17.68	500	Complies

Configuration IEEE 802.11n MCS16 40MHz / Chain 1 + Chain 2 + Chain 3

Channel	Frequency	6dB Bandwidth (MHz)	99% Occupied Bandwidth (MHz)	Min. Limit (kHz)	Test Result
3	2422 MHz	33.76	36.32	500	Complies
6	2437 MHz	36.00	36.32	500	Complies
9	2452 MHz	36.32	36.48	500	Complies

Configuration IEEE 802.11b / Chain 1

Channel	Frequency	6dB Bandwidth (MHz)	99% Occupied Bandwidth (MHz)	Min. Limit (kHz)	Test Result
1	2412 MHz	10.08	13.92	500	Complies
6	2437 MHz	10.00	13.84	500	Complies
11	2462 MHz	10.08	13.84	500	Complies

Configuration IEEE 802.11b / Chain 1 + Chain 2

Channel	Frequency	6dB Bandwidth (MHz)	99% Occupied Bandwidth (MHz)	Min. Limit (kHz)	Test Result
1	2412 MHz	12.48	15.28	500	Complies
6	2437 MHz	5.60	15.20	500	Complies
11	2462 MHz	5.36	15.04	500	Complies

Configuration IEEE 802.11b / Chain 1 + Chain 2 + Chain 3

Channel	Frequency	6dB Bandwidth (MHz)	99% Occupied Bandwidth (MHz)	Min. Limit (kHz)	Test Result
1	2412 MHz	6.56	10.16	500	Complies
6	2437 MHz	7.04	10.00	500	Complies
11	2462 MHz	10.64	13.04	500	Complies

Configuration IEEE 802.11g / Chain 1

Channel	Frequency	6dB Bandwidth (MHz)	99% Occupied Bandwidth (MHz)	Min. Limit (kHz)	Test Result
1	2412 MHz	16.32	16.56	500	Complies
6	2437 MHz	16.32	16.64	500	Complies
11	2462 MHz	16.40	16.64	500	Complies

Configuration IEEE 802.11g / Chain 1 + Chain 2

Channel	Frequency	6dB Bandwidth (MHz)	99% Occupied Bandwidth (MHz)	Min. Limit (kHz)	Test Result
1	2412 MHz	16.48	16.64	500	Complies
6	2437 MHz	16.32	16.72	500	Complies
11	2462 MHz	16.40	16.64	500	Complies

Configuration IEEE 802.11g / Chain 1 + Chain 2 + Chain 3

Channel	Frequency	6dB Bandwidth (MHz)	99% Occupied Bandwidth (MHz)	Min. Limit (kHz)	Test Result
1	2412 MHz	16.40	16.56	500	Complies
6	2437 MHz	11.04	15.76	500	Complies
11	2462 MHz	13.04	16.08	500	Complies

Temperature	24°C	Humidity	61%
Test Engineer	Kenneth Huang	Configurations	IEEE 802.11a/n
Test Mode	Mode 2 (Ant.31 PIFA antenna / 4.7dBi)		

For 5GHz Band
Configuration IEEE 802.11n MCS0 20MHz / Chain 1

Channel	Frequency	6dB Bandwidth (MHz)	99% Occupied Bandwidth (MHz)	Min. Limit (kHz)	Test Result
149	5745 MHz	17.20	30.32	500	Complies
157	5785 MHz	16.80	30.00	500	Complies
165	5825 MHz	17.28	32.00	500	Complies

Configuration IEEE 802.11n MCS0 40MHz / Chain 1

Channel	Frequency	6dB Bandwidth (MHz)	99% Occupied Bandwidth (MHz)	Min. Limit (kHz)	Test Result
151	5755 MHz	36.48	65.92	500	Complies
159	5795 MHz	31.36	67.36	500	Complies

Configuration IEEE 802.11n MCS8 20MHz / Chain 1 + Chain 2

Channel	Frequency	6dB Bandwidth (MHz)	99% Occupied Bandwidth (MHz)	Min. Limit (kHz)	Test Result
149	5745 MHz	15.12	29.60	500	Complies
157	5785 MHz	14.64	30.08	500	Complies
165	5825 MHz	15.68	29.92	500	Complies

Configuration IEEE 802.11n MCS8 40MHz / Chain 1 + Chain 2

Channel	Frequency	6dB Bandwidth (MHz)	99% Occupied Bandwidth (MHz)	Min. Limit (kHz)	Test Result
151	5755 MHz	35.20	67.52	500	Complies
159	5795 MHz	35.04	67.52	500	Complies

Configuration IEEE 802.11n MCS16 20MHz / Chain 1 + Chain 2 + Chain 3

Channel	Frequency	6dB Bandwidth (MHz)	99% Occupied Bandwidth (MHz)	Min. Limit (kHz)	Test Result
149	5745 MHz	16.48	24.16	500	Complies
157	5785 MHz	15.60	24.88	500	Complies
165	5825 MHz	14.72	26.88	500	Complies

Configuration IEEE 802.11n MCS16 40MHz / Chain 1 + Chain 2 + Chain 3

Channel	Frequency	6dB Bandwidth (MHz)	99% Occupied Bandwidth (MHz)	Min. Limit (kHz)	Test Result
151	5755 MHz	34.88	54.08	500	Complies
159	5795 MHz	33.28	59.84	500	Complies

Configuration IEEE 802.11a / Chain 1

Channel	Frequency	6dB Bandwidth (MHz)	99% Occupied Bandwidth (MHz)	Min. Limit (kHz)	Test Result
149	5745 MHz	16.32	28.88	500	Complies
157	5785 MHz	16.32	29.20	500	Complies
165	5825 MHz	16.08	30.96	500	Complies

Note: All the test values were listed in the report.

For plots, only the channel with worse result was shown.

For 2.4GHz Band

6 dB Bandwidth Plot on Configuration IEEE 802.11n MCS0 20MHz / 2437 MHz / Chain 1

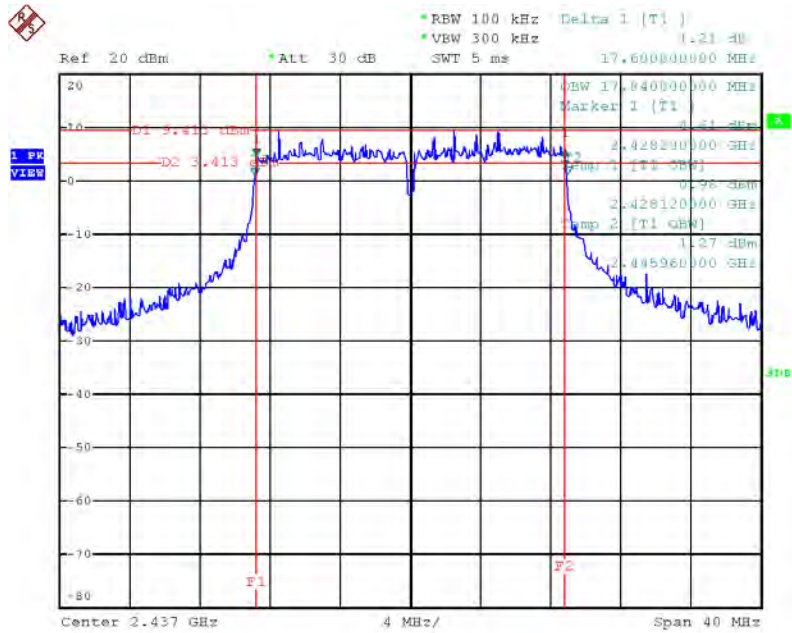

Date: 20.SEP.2013 15:57:06

6 dB Bandwidth Plot on Configuration IEEE 802.11n MCS0 40MHz / 2437 MHz / Chain 1

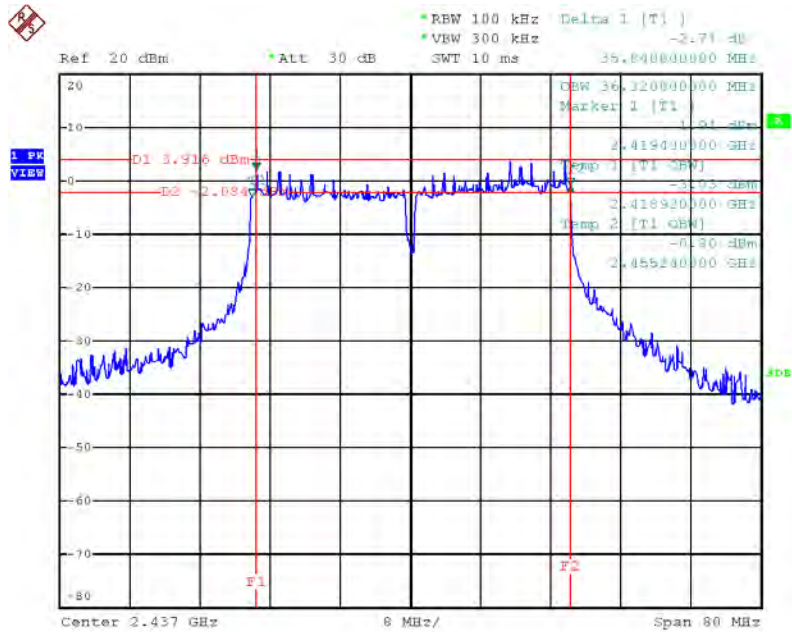

Date: 20.SEP.2013 16:01:54

6 dB Bandwidth Plot on Configuration IEEE 802.11n MCS0 20MHz / 2437 MHz / Chain 1 + Chain 2

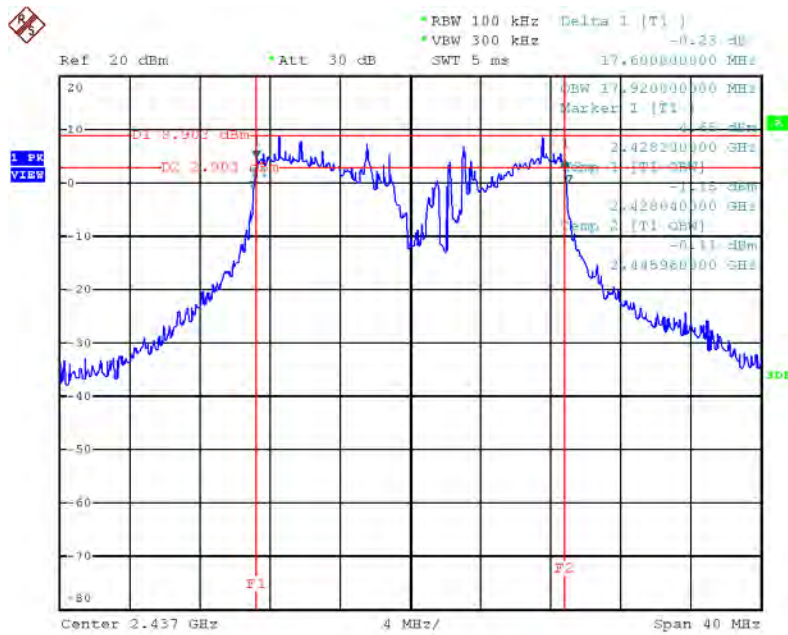

Date: 20.SEP.2013 16:13:31

6 dB Bandwidth Plot on Configuration IEEE 802.11n MCS0 40MHz / 2437 MHz / Chain 1 + Chain 2

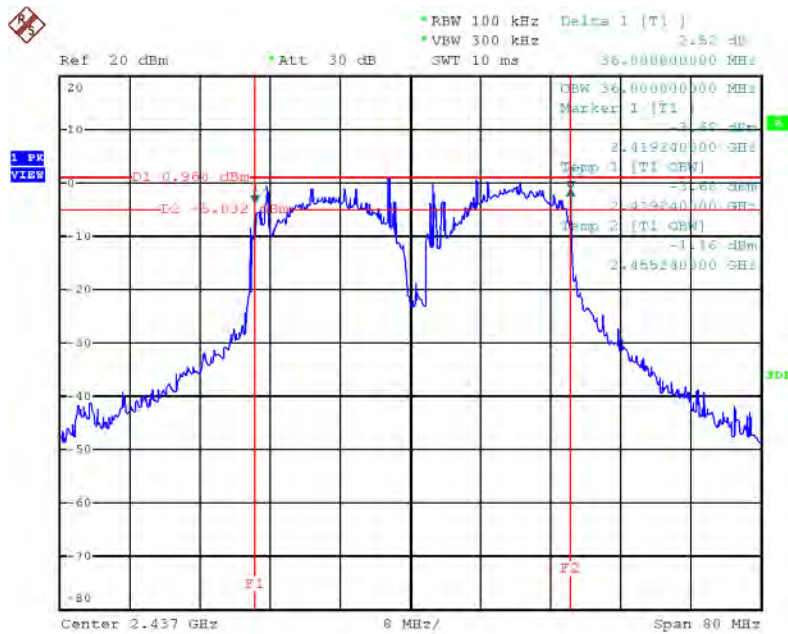

Date: 20.SEP.2013 16:15:35

6 dB Bandwidth Plot on Configuration IEEE 802.11n MCS0 20MHz / 2412 MHz / Chain 1 + Chain 2 + Chain 3

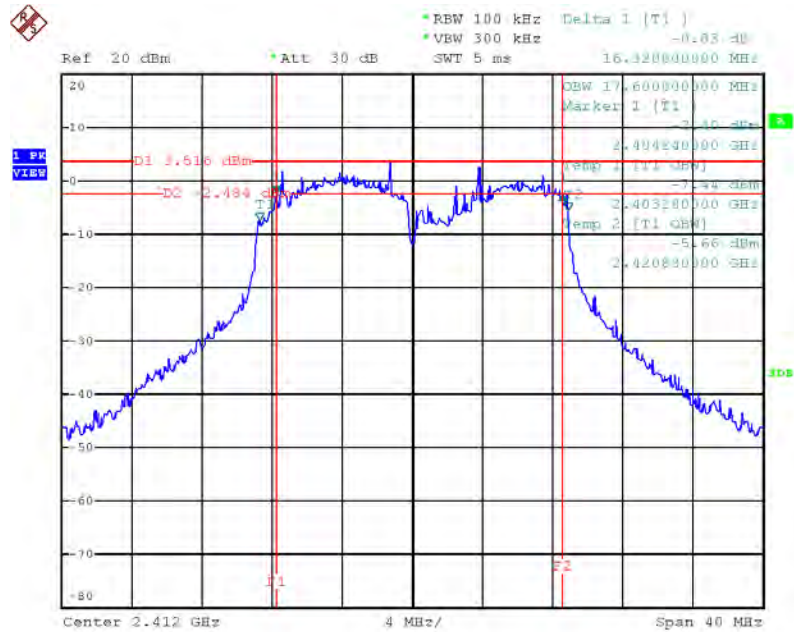

Date: 20.SEP.2013 16:39:07

6 dB Bandwidth Plot on Configuration IEEE 802.11n MCS0 40MHz / 2437 MHz / Chain 1 + Chain 2 + Chain 3

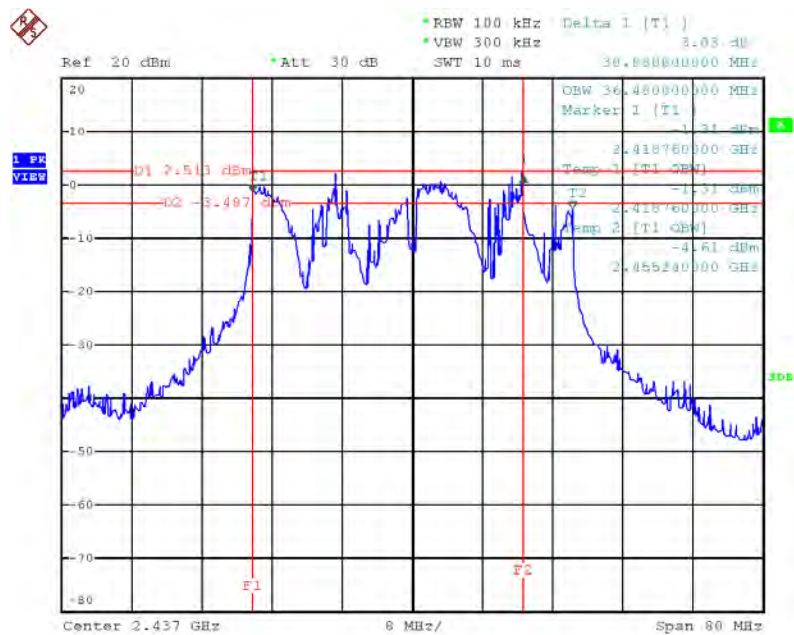

Date: 20.SEP.2013 16:49:46

6 dB Bandwidth Plot on Configuration IEEE 802.11n MCS8 20MHz / 2437 MHz / Chain 1 + Chain 2

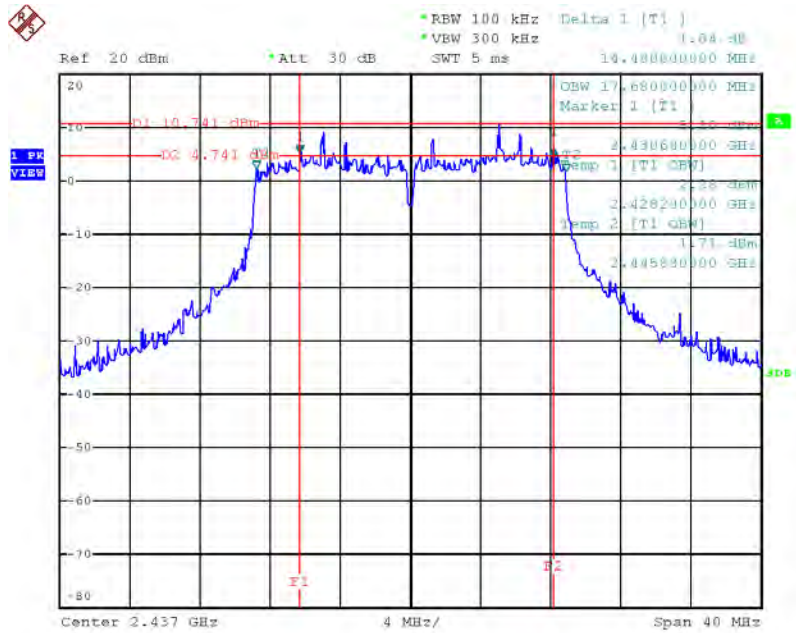

Date: 20.SEP.2013 16:30:17

6 dB Bandwidth Plot on Configuration IEEE 802.11n MCS8 40MHz / 2452 MHz / Chain 1 + Chain 2

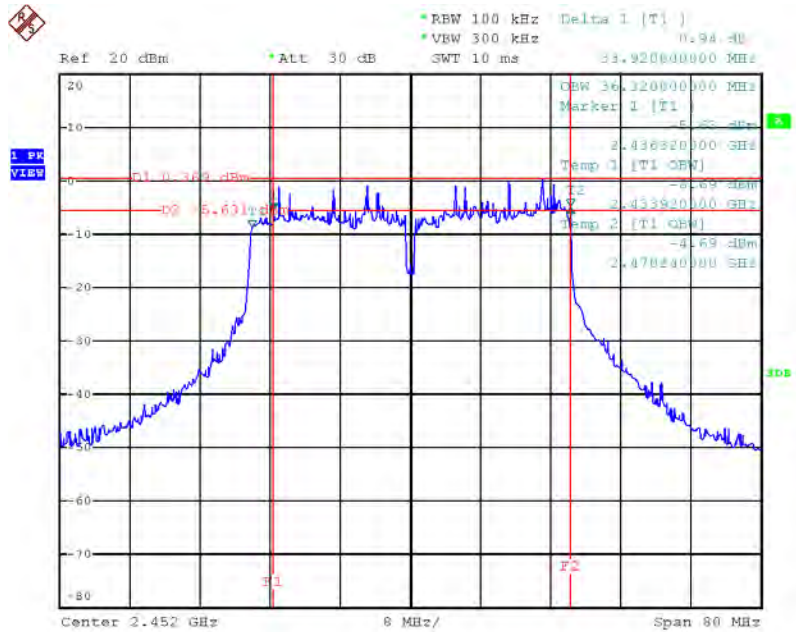

Date: 20.SEP.2013 16:17:24

6 dB Bandwidth Plot on Configuration IEEE 802.11n MCS8 20MHz / 2462 MHz / Chain 1 + Chain 2 + Chain 3

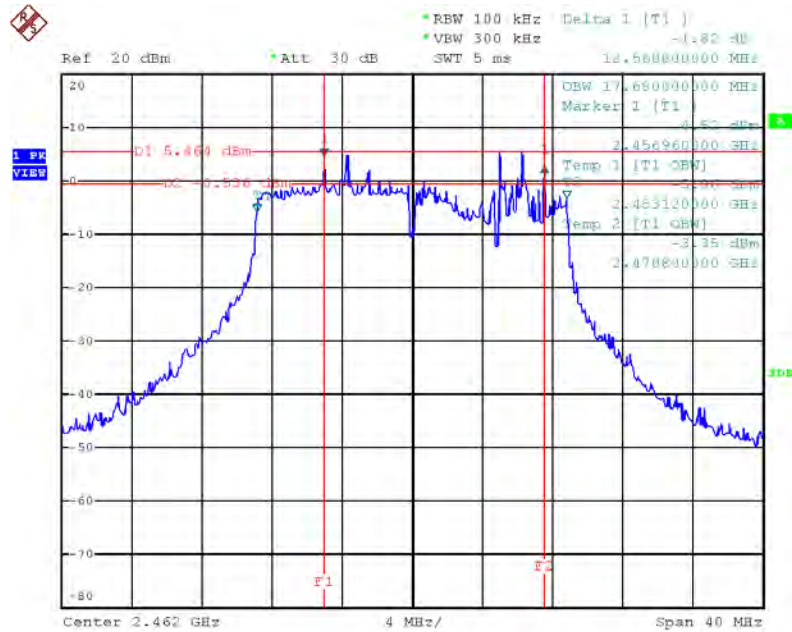

Date: 20.SEP.2013 16:40:51

6 dB Bandwidth Plot on Configuration IEEE 802.11n MCS8 40MHz / 2437 MHz / Chain 1 + Chain 2 + Chain 3

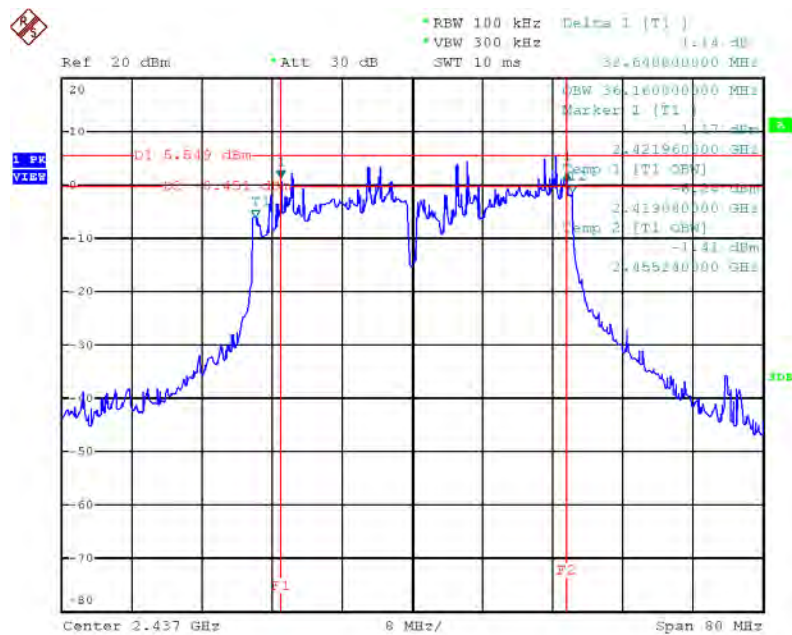

Date: 20.SEP.2013 16:47:42

6 dB Bandwidth Plot on Configuration IEEE 802.11n MCS16 20MHz / 2462 MHz / Chain 1 + Chain 2 + Chain 3

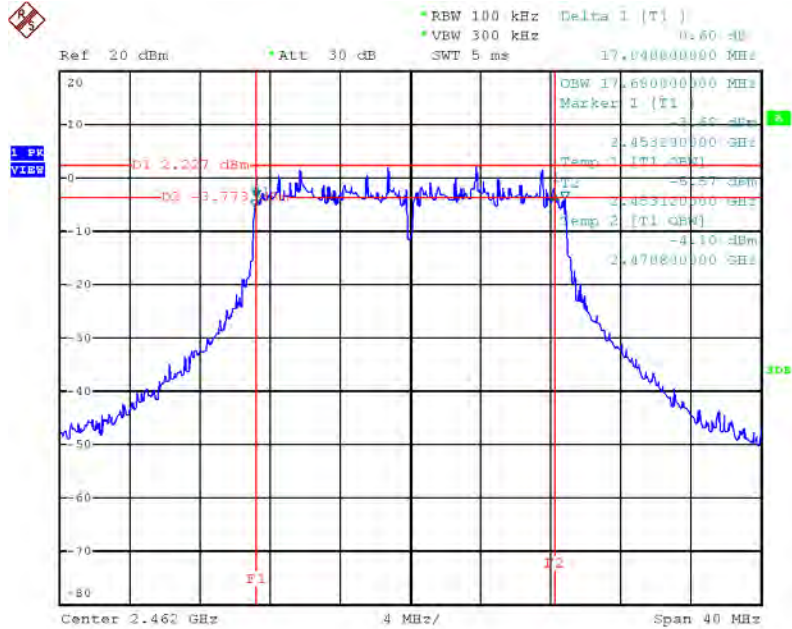

Date: 20.SEP.2013 16:44:00

6 dB Bandwidth Plot on Configuration IEEE 802.11n MCS16 40MHz / 2422 MHz / Chain 1 + Chain 2 + Chain 3

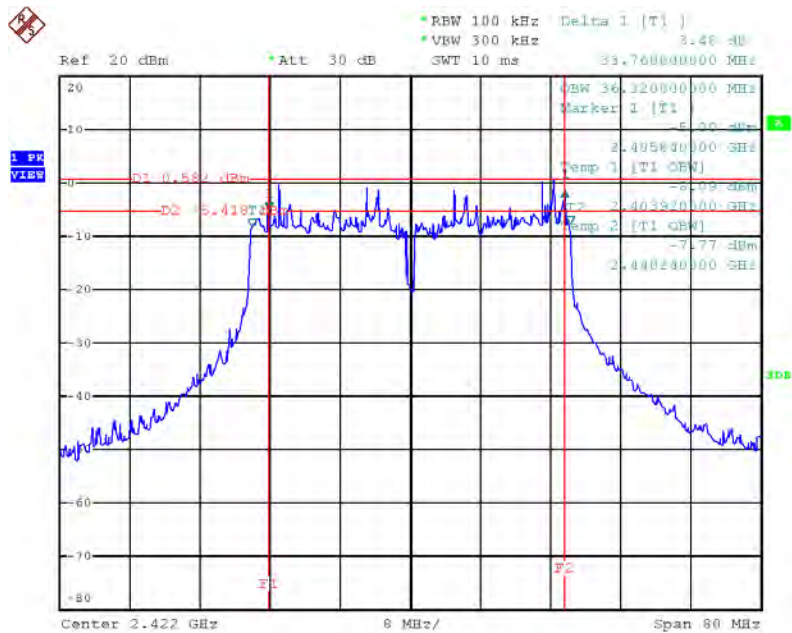

Date: 20.SEP.2013 16:44:59

6 dB Bandwidth Plot on Configuration IEEE 802.11b / 2437 MHz / Chain 1

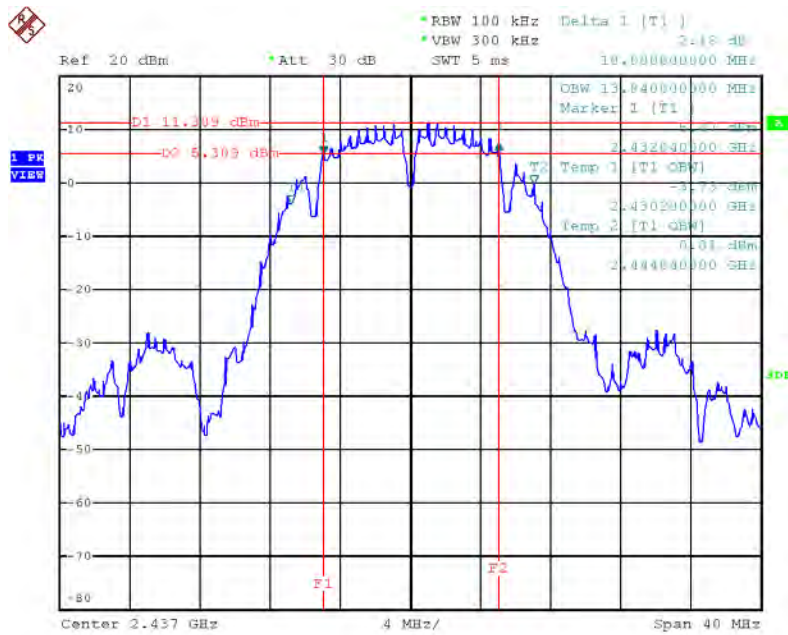

Date: 20.SEP.2013 15:52:36

6 dB Bandwidth Plot on Configuration IEEE 802.11b / 2462 MHz / Chain 1 + Chain 2

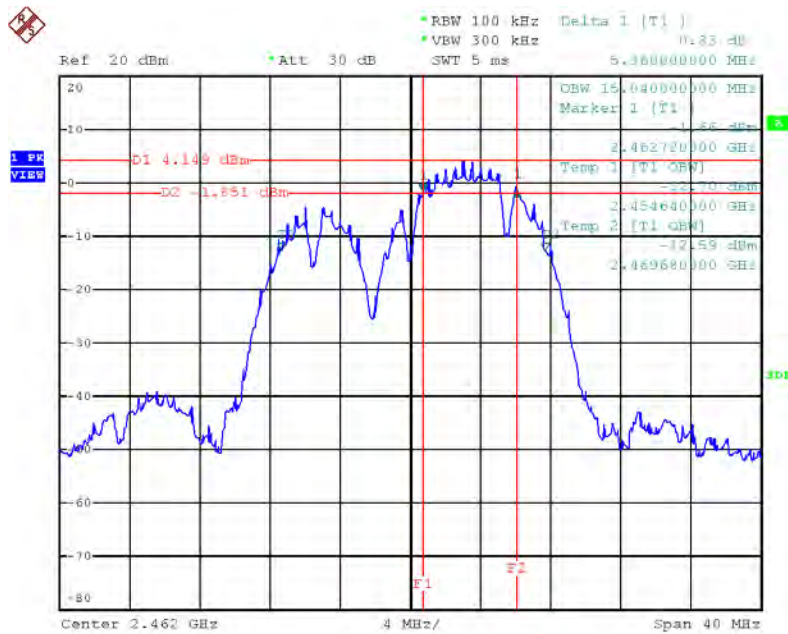

Date: 20.SEP.2013 16:10:22

6 dB Bandwidth Plot on Configuration IEEE 802.11b / 2412 MHz / Chain 1 + Chain 2 + Chain 3

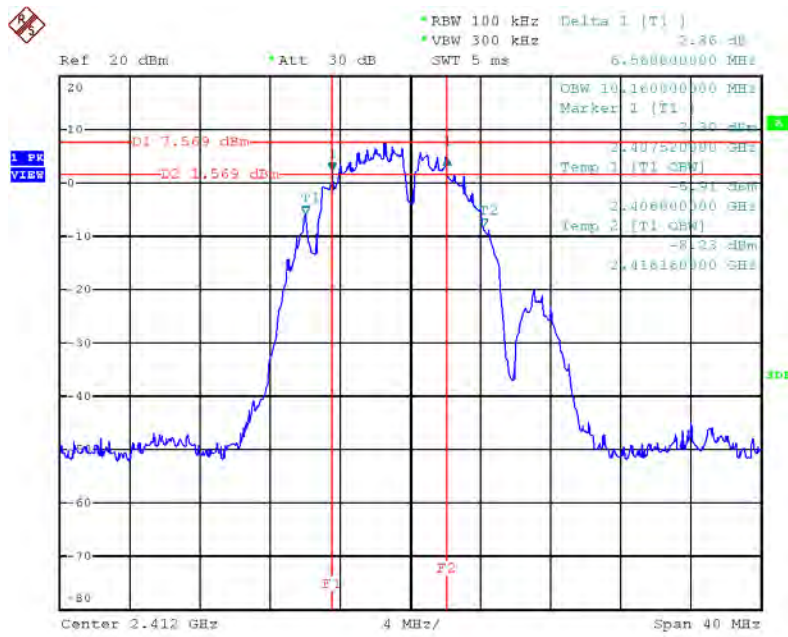

Date: 20.SEP.2013 16:35:26

6 dB Bandwidth Plot on Configuration IEEE 802.11g / 2412 MHz / Chain 1

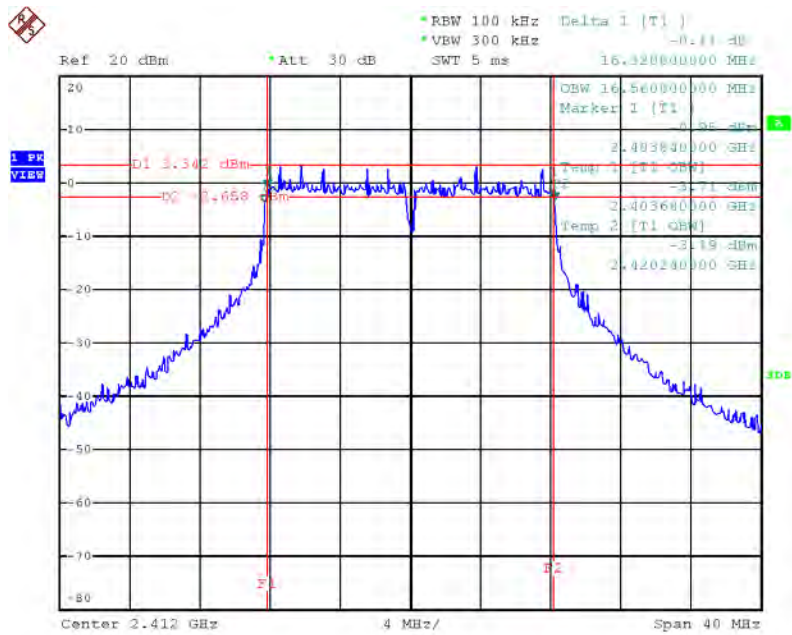

Date: 20.SEP.2013 15:55:15

6 dB Bandwidth Plot on Configuration IEEE 802.11g / 2437 MHz / Chain 1 + Chain 2

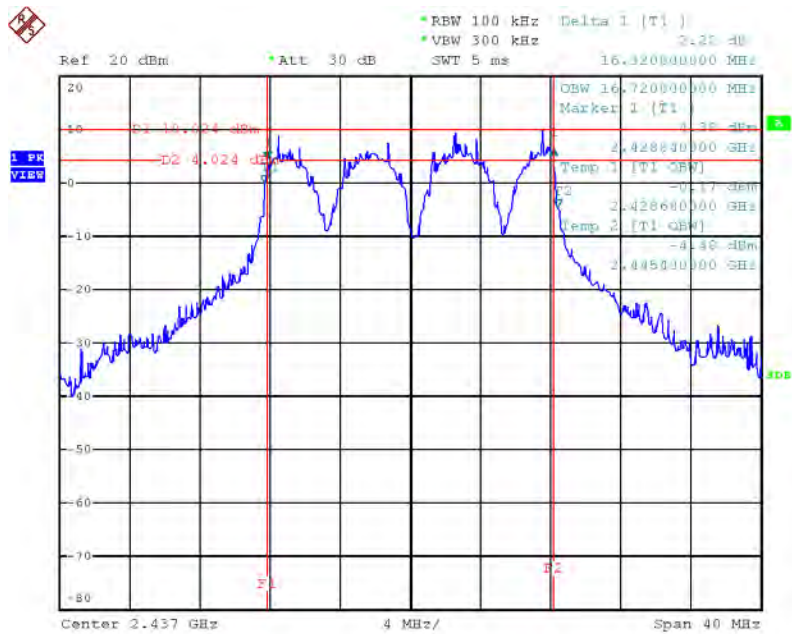

Date: 20.SEP.2013 16:11:38

6 dB Bandwidth Plot on Configuration IEEE 802.11g / 2437 MHz / Chain 1 + Chain 2 + Chain 3

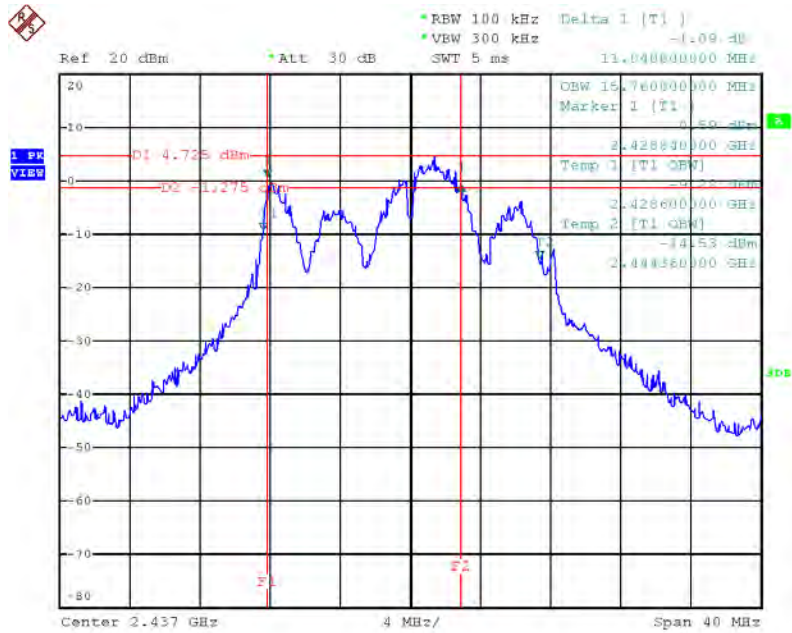

Date: 20.SEP.2013 16:37:47

For 5GHz Band

6 dB Bandwidth Plot on Configuration IEEE 802.11n MCS0 20MHz / 5785 MHz / Chain 1

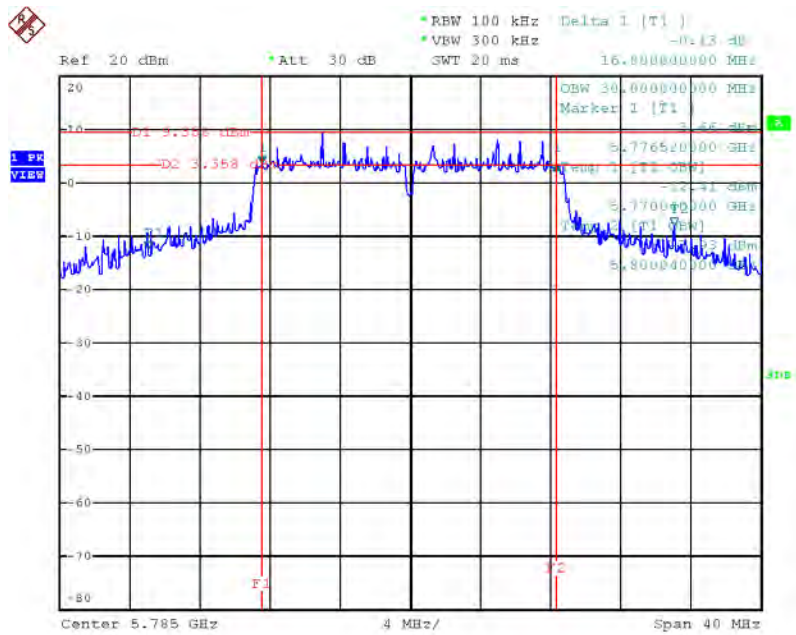

Date: 18.SEP.2013 16:50:34

6 dB Bandwidth Plot on Configuration IEEE 802.11n MCS0 40MHz / 5795 MHz / Chain 1

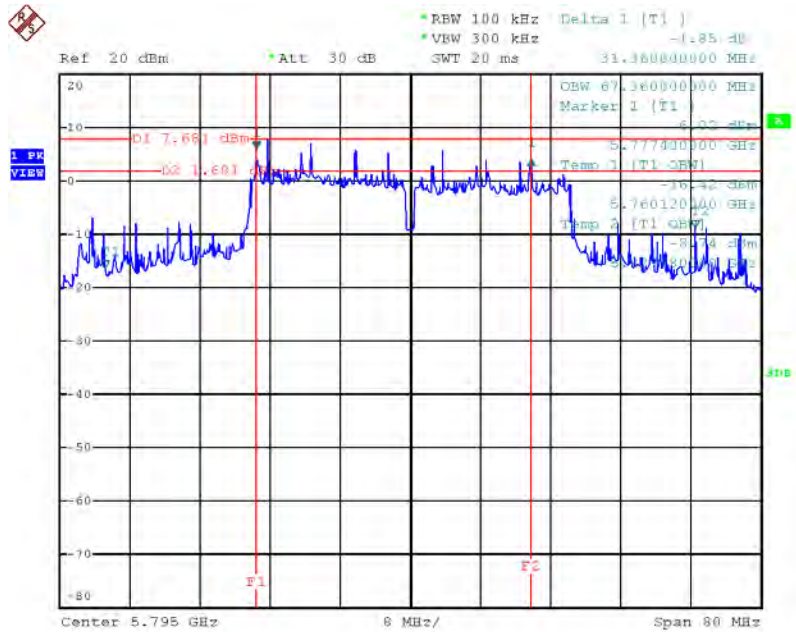

Date: 18.SEP.2013 17:17:07

6 dB Bandwidth Plot on Configuration IEEE 802.11n MCS8 20MHz / 5785MHz / Chain 1 + Chain 2

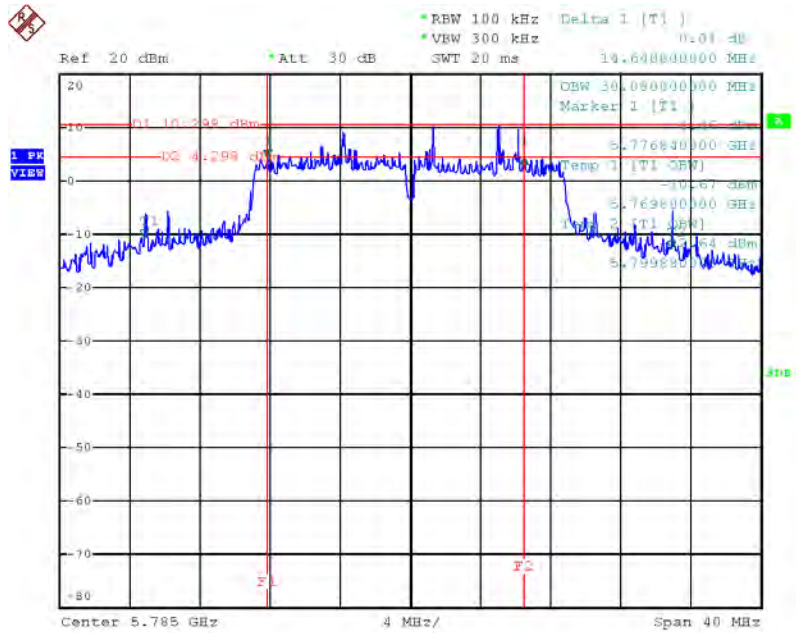

Date: 18.SEP.2013 17:12:58

6 dB Bandwidth Plot on Configuration IEEE 802.11n MCS8 40MHz / 5795MHz / Chain 1 + Chain 2

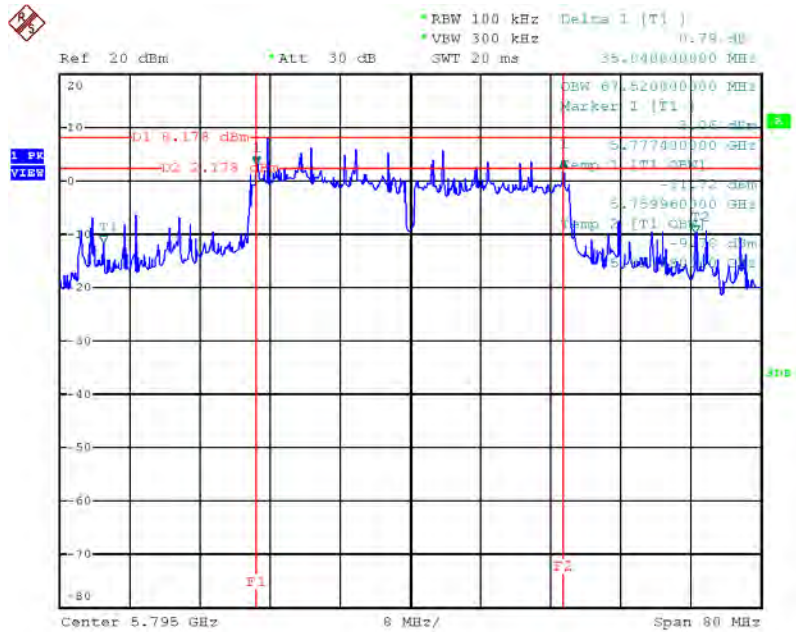

Date: 18.SEP.2013 17:16:08

6 dB Bandwidth Plot on Configuration IEEE 802.11n MCS16 20MHz / 5825MHz / Chain 1 + Chain 2 + Chain 3

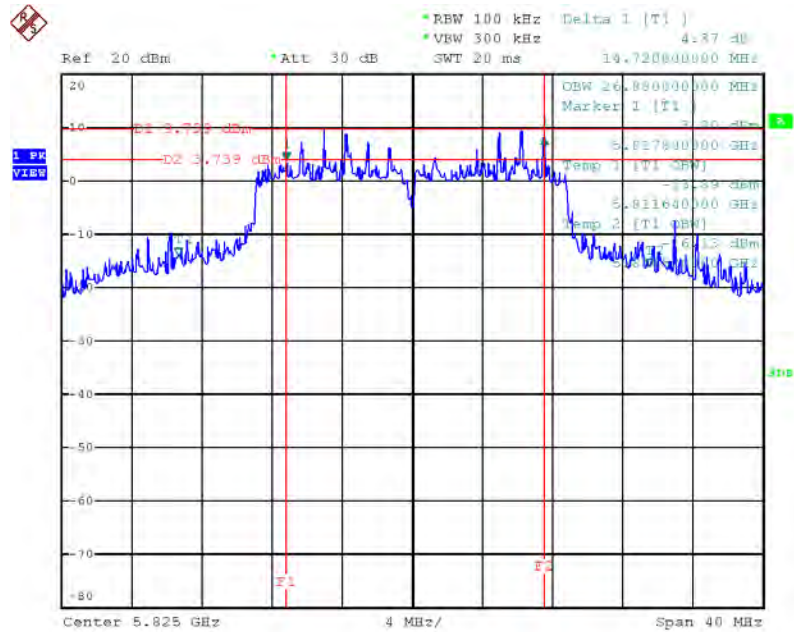

Date: 18.SEP.2013 17:20:04

6 dB Bandwidth Plot on Configuration IEEE 802.11n MCS16 40MHz / 5795MHz / Chain 1 + Chain 2 + Chain 3

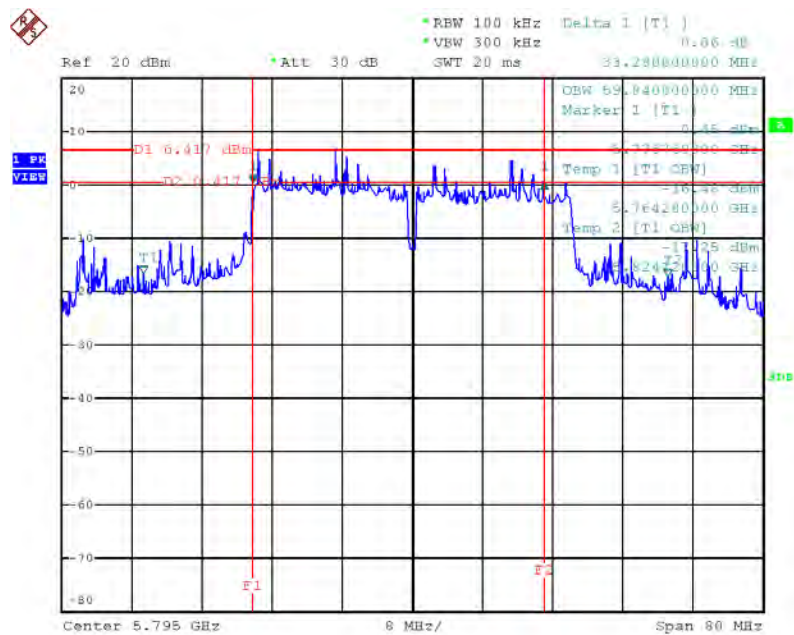

Date: 18.SEP.2013 17:22:01

6 dB Bandwidth Plot on Configuration IEEE 802.11a / 5825 MHz / Chain 1

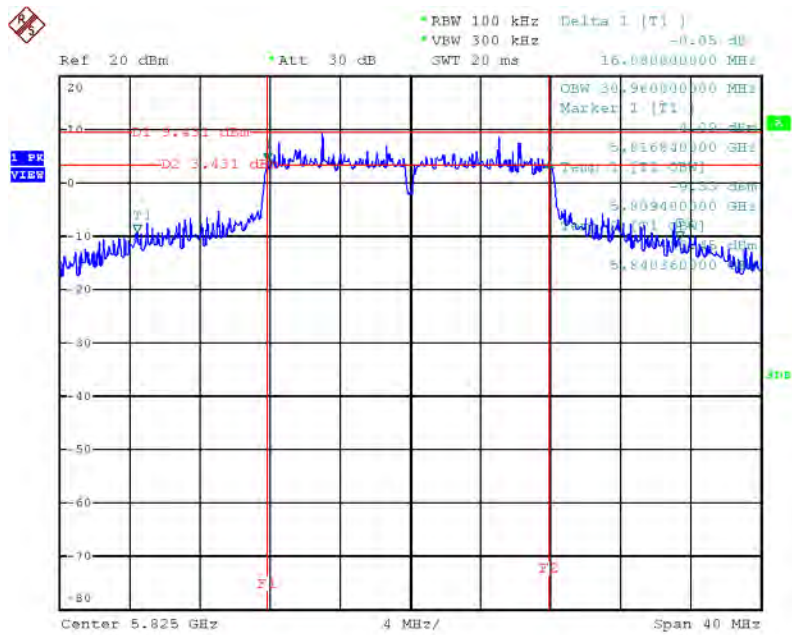

Date: 18.SEP.2013 16:02:17

4.4. Radiated Emissions Measurement

4.4.1. Limit

30dBc in any 100 kHz bandwidth outside the operating frequency band. In case the emission fall within the restricted band specified on 15.205(a), then the 15.209(a) limit in the table below has to be followed.

Frequencies (MHz)	Field Strength (micorvolts/meter)	Measurement Distance (meters)
0.009~0.490	2400/F(kHz)	300
0.490~1.705	24000/F(kHz)	30
1.705~30.0	30	30
30~88	100	3
88~216	150	3
216~960	200	3
Above 960	500	3

4.4.2. Measuring Instruments and Setting

Please refer to section 5 of equipments list in this report. The following table is the setting of spectrum analyzer and receiver.

Spectrum Parameter	Setting
Attenuation	Auto
Start Frequency	1000 MHz
Stop Frequency	10th carrier harmonic
RBW / VBW (Emission in restricted band)	1MHz / 3MHz for Peak, 1MHz / 10Hz for Average
RBW / VBW (Emission in non-restricted band)	100kHz / 300kHz for peak

Receiver Parameter	Setting
Attenuation	Auto
Start ~ Stop Frequency	9kHz~150kHz / RBW 200Hz for QP
Start ~ Stop Frequency	150kHz~30MHz / RBW 9kHz for QP
Start ~ Stop Frequency	30MHz~1000MHz / RBW 120kHz for QP

4.4.3. Test Procedures

1. Configure the EUT according to ANSI C63.10. The EUT was placed on the top of the turntable 0.8 meter above ground. The phase center of the receiving antenna mounted on the top of a height-variable antenna tower was placed 3 meters far away from the turntable.
2. Power on the EUT and all the supporting units. The turntable was rotated by 360 degrees to determine the position of the highest radiation.
3. The height of the broadband receiving antenna was varied between one meter and four meters above ground to find the maximum emissions field strength of both horizontal and vertical polarization.
4. For each suspected emissions, the antenna tower was scan (from 1 M to 4 M) and then the turntable was rotated (from 0 degree to 360 degrees) to find the maximum reading.
5. Set the test-receiver system to Peak or CISPR quasi-peak Detect Function with specified bandwidth under Maximum Hold Mode.
6. For emissions above 1GHz, use 1MHz VBW and 3MHz RBW for peak reading. Then 1MHz RBW and 10Hz VBW for average reading in spectrum analyzer.
7. When the radiated emissions limits are expressed in terms of the average value of the emissions, and pulsed operation is employed, the measurement field strength shall be determined by averaging over one complete pulse train, including blanking intervals, as long as the pulse train does not exceed 0.1 seconds. As an alternative (provided the transmitter operates for longer than 0.1 seconds) or in cases where the pulse train exceeds 0.1 seconds, the measured field strength shall be determined from the average absolute voltage during a 0.1 second interval during which the field strength is at its maximum value.
8. If the emissions level of the EUT in peak mode was 3 dB lower than the average limit specified, then testing will be stopped and peak values of EUT will be reported, otherwise, the emissions which do not have 3 dB margin will be repeated one by one using the quasi-peak method for below 1GHz.
9. For testing above 1GHz, the emissions level of the EUT in peak mode was lower than average limit (that means the emissions level in peak mode also complies with the limit in average mode), then testing will be stopped and peak values of EUT will be reported, otherwise, the emissions will be measured in average mode again and reported.
10. In case the emission is lower than 30MHz, loop antenna has to be used for measurement and the recorded data should be QP measured by receiver. High – Low scan is not required in this case.

4.4.4. Test Setup Layout

For Radiated Emissions: 9kHz ~30MHz

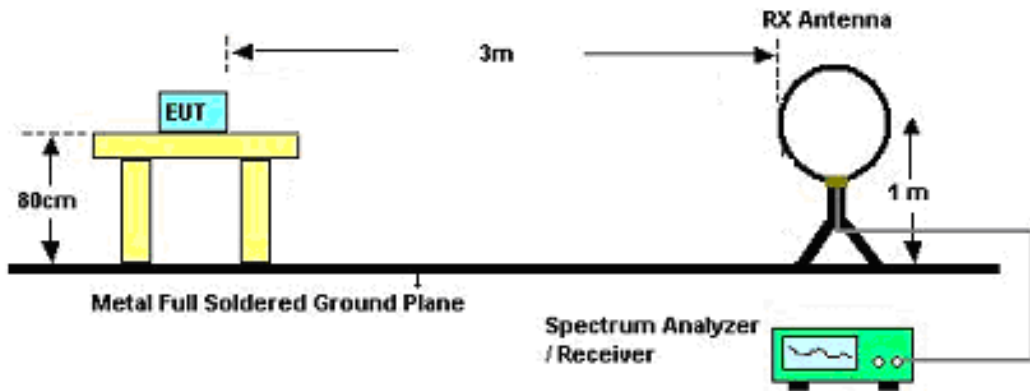

For Radiated Emissions: 30MHz~1GHz

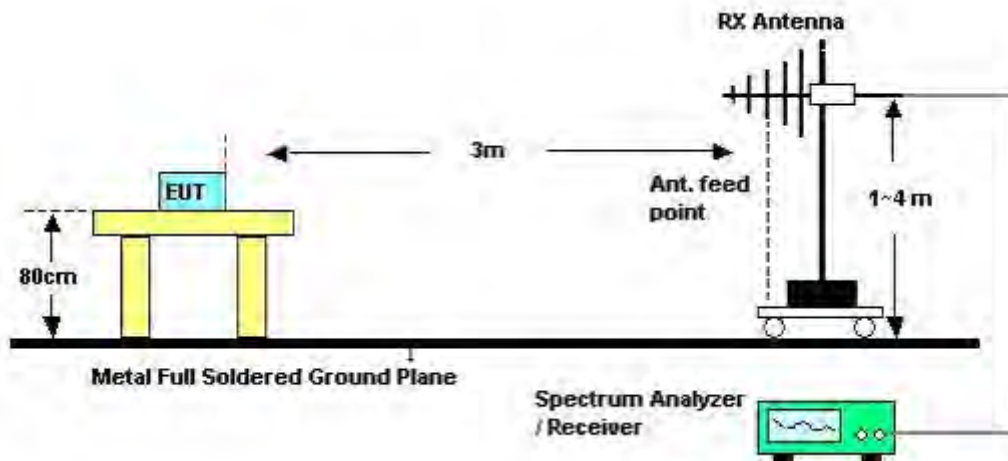

For Radiated Emissions: Above 1GHz

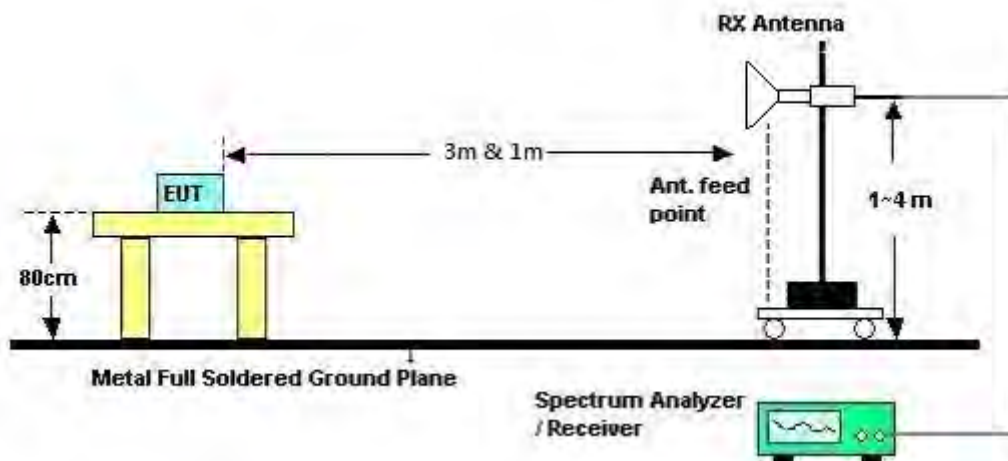

4.4.5. Test Deviation

There is no deviation with the original standard.

4.4.6. EUT Operation during Test

The EUT was programmed to be in continuously transmitting mode.

4.4.7. Results of Radiated Emissions (9kHz~30MHz)

Temperature	25°C	Humidity	54%
Test Engineer	Jim Huang	Configurations	CTX
Test Date	Sep. 23, 2013	Test Mode	Mode 1

Freq. (MHz)	Level (dBuV)	Over Limit (dB)	Limit Line (dBuV)	Remark
-	-	-	-	See Note

Note:

The amplitude of spurious emissions that are attenuated by more than 20 dB below the permissible value has no need to be reported.

Distance extrapolation factor = $40 \log(\text{specific distance} / \text{test distance})$ (dB);

Limit line = specific limits (dBuV) + distance extrapolation factor.

4.4.8. Results of Radiated Emissions (30MHz~1GHz)

Temperature	25°C	Humidity	54%
Test Engineer	Jim Huang	Configurations	CTX
Test Mode	Mode 1		

Horizontal

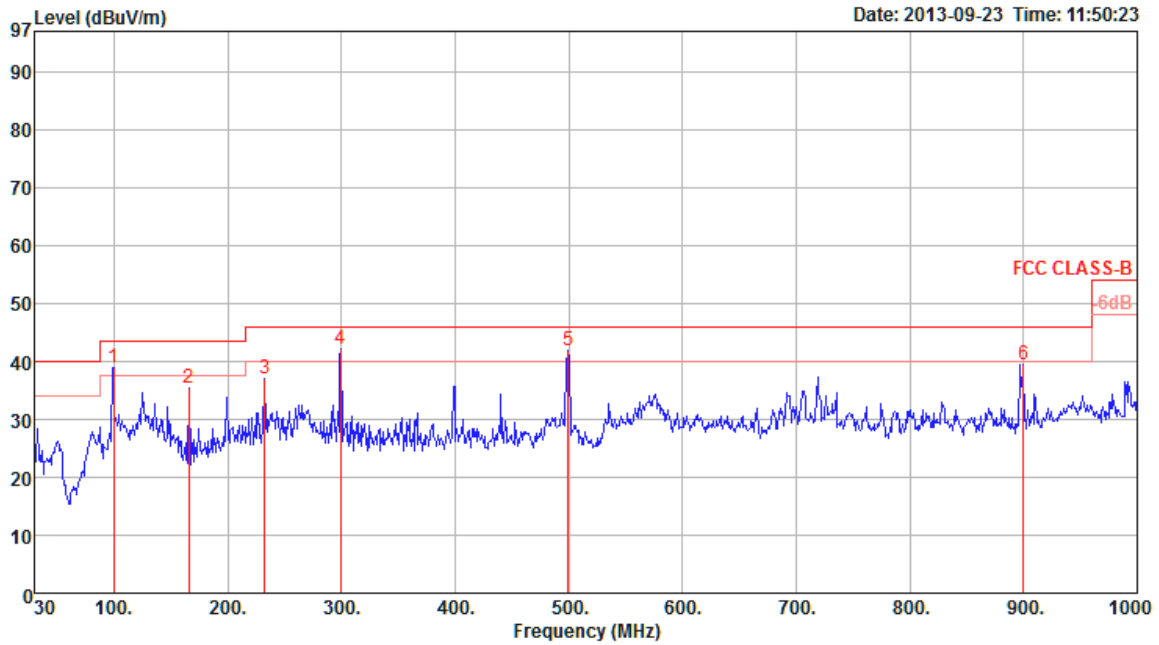

	Freq	Level	Limit Line	Over Limit	Read Level	Cable Loss	Preamp Factor	Antenna Factor	Remark	T/Pos	A/Pos	Pol/Phase
	MHz	dBuV/m	dBuV/m	dB	dBuV	dB	dB	dB/m		deg	cm	
1	99.84	38.97	43.50	-4.53	53.89	1.50	27.82	11.40	Peak	0	400	HORIZONTAL
2	165.80	35.48	43.50	-8.02	50.55	1.92	27.41	10.42	Peak	0	400	HORIZONTAL
3	232.73	36.97	46.00	-9.03	50.15	2.29	27.01	11.54	Peak	0	400	HORIZONTAL
4	299.66	42.04	46.00	-3.96	52.56	2.51	26.83	13.80	Peak	0	400	HORIZONTAL
5	499.48	41.88	46.00	-4.12	48.65	3.38	27.93	17.78	Peak	0	400	HORIZONTAL
6	900.09	39.55	46.00	-6.45	40.28	4.60	26.83	21.50	Peak	0	400	HORIZONTAL

Vertical

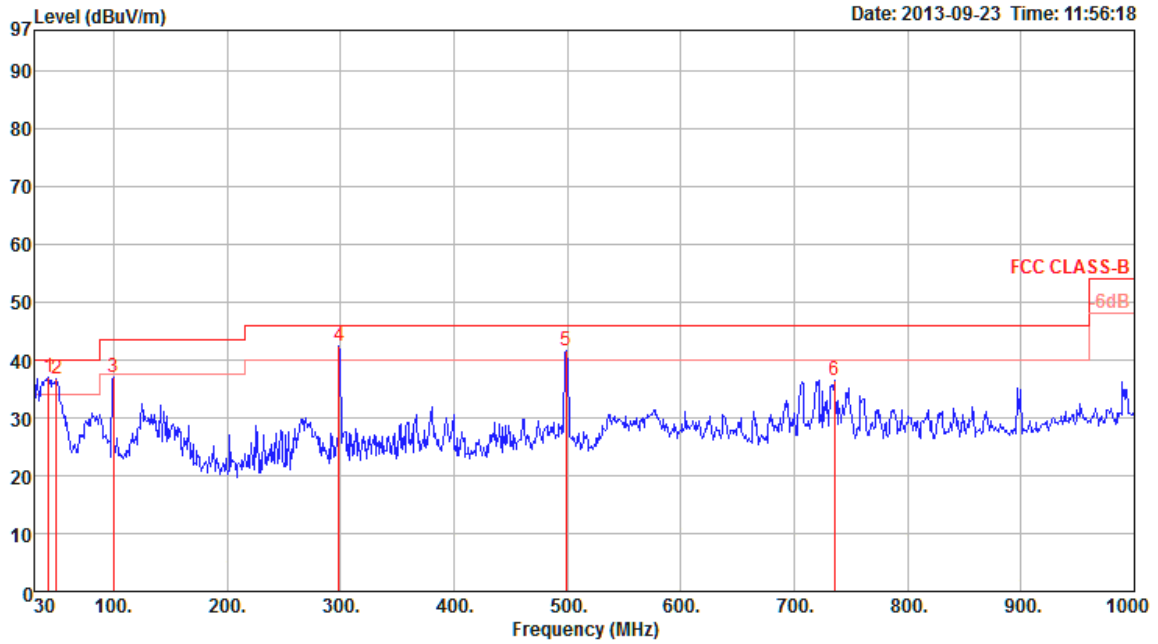

	Freq	Level	Limit	Over	Read	Cable	Preamp	Antenna	Remark	T/Pos	A/Pos	Pol/Phase
	MHz	dBuV/m	dBuV/m	dB	dBuV	dB	dB	dB/m		deg	cm	
1	42.61	36.92	40.00	-3.08	51.92	1.00	27.96	11.96	Peak	0	100	VERTICAL
2	49.40	36.73	40.00	-3.27	54.55	1.05	27.92	9.05	Peak	0	100	VERTICAL
3	99.84	36.96	43.50	-6.54	51.88	1.50	27.82	11.40	Peak	0	100	VERTICAL
4	298.69	42.37	46.00	-3.63	52.89	2.51	26.83	13.80	Peak	0	100	VERTICAL
5	498.51	41.60	46.00	-4.40	48.38	3.38	27.93	17.77	Peak	0	100	VERTICAL
6	735.19	36.59	46.00	-9.41	39.37	4.19	27.11	20.14	Peak	0	100	VERTICAL

Note:

The amplitude of spurious emissions that are attenuated by more than 20dB below the permissible value has no need to be reported.

Emission level (dBuV/m) = 20 log Emission level (uV/m).

Corrected Reading: Antenna Factor + Cable Loss + Read Level - Preamp Factor = Level.

4.4.9. Results for Radiated Emissions (1GHz~10th Harmonic)

Temperature	25°C	Humidity	54%
Test Engineer	Kenneth Huang	Configurations	IEEE 802.11n MCS0 20MHz CH 1 / 1TX / Chain 1
Test Date	Aug. 13, 2013	Test Mode	Mode 1 (Ant.31 PIFA antenna / 4.4dBi)

Horizontal

	Freq	Level	Limit Line	Over Limit	Read Level	CableAntenna Loss	Antenna Factor	Preamp Factor	Remark	A/Pos	T/Pos	Pol/Phase
	MHz	dBuV/m	dBuV/m	dB	dBuV	dB	dB/m	dB		cm	deg	
1	4820.99	42.71	74.00	-31.29	41.37	3.31	33.06	35.03	Peak	100	68	HORIZONTAL
2	4831.28	30.04	54.00	-23.96	28.70	3.31	33.06	35.03	Average	100	68	HORIZONTAL

Vertical

	Freq	Level	Limit Line	Over Limit	Read Level	CableAntenna Loss	Antenna Factor	Preamp Factor	Remark	A/Pos	T/Pos	Pol/Phase
	MHz	dBuV/m	dBuV/m	dB	dBuV	dB	dB/m	dB		cm	deg	
1	4821.31	42.41	74.00	-31.59	41.07	3.31	33.06	35.03	Peak	100	311	VERTICAL
2	4829.83	30.17	54.00	-23.83	28.83	3.31	33.06	35.03	Average	100	311	VERTICAL

Temperature	25°C	Humidity	54%
Test Engineer	Kenneth Huang	Configurations	IEEE 802.11n MCS0 20MHz CH 6 / 1TX / Chain 1
Test Date	Aug. 13, 2013	Test Mode	Mode 1 (Ant.31 PIFA antenna / 4.4dBi)

Horizontal

	Freq	Level	Limit	Over	Read	CableAntenna	Preamp	Remark	A/Pos	T/Pos	Pol/Phase	
	MHz	dBuV/m	dBuV/m	dB	dBuV	dB	dB/m	dB	cm	deg		
1	4876.15	45.11	74.00	-28.89	43.65	3.33	33.16	35.03	Peak	179	332	HORIZONTAL
2	4876.34	30.89	54.00	-23.11	29.43	3.33	33.16	35.03	Average	179	332	HORIZONTAL
3	7311.83	62.03	74.00	-11.97	57.41	4.06	35.96	35.40	Peak	152	141	HORIZONTAL
4	7313.28	45.22	54.00	-8.78	40.60	4.06	35.96	35.40	Average	152	141	HORIZONTAL

Vertical

	Freq	Level	Limit	Over	Read	CableAntenna	Preamp	Remark	A/Pos	T/Pos	Pol/Phase	
	MHz	dBuV/m	dBuV/m	dB	dBuV	dB	dB/m	dB	cm	deg		
1	4874.45	45.26	74.00	-28.74	43.80	3.33	33.16	35.03	Peak	100	339	VERTICAL
2	4874.83	31.08	54.00	-22.92	29.62	3.33	33.16	35.03	Average	100	339	VERTICAL
3	7308.56	64.24	74.00	-9.76	59.62	4.06	35.96	35.40	Peak	101	41	VERTICAL
4	7310.55	47.36	54.00	-6.64	42.74	4.06	35.96	35.40	Average	101	41	VERTICAL

Temperature	25°C	Humidity	54%
Test Engineer	Kenneth Huang	Configurations	IEEE 802.11n MCS0 20MHz CH 11 / 1TX / Chain 1
Test Date	Aug. 13, 2013	Test Mode	Mode 1 (Ant.31 PIFA antenna / 4.4dBi)

Horizontal

	Freq	Level	Limit Line	Over Limit	Read Level	CableAntenna Loss	Antenna Factor	Preamp Factor	Remark	A/Pos	T/Pos	Pol/Phase
	MHz	dBuV/m	dBuV/m	dB	dBuV	dB	dB/m	dB		cm	deg	
1	4918.87	30.48	54.00	-23.52	28.92	3.35	33.23	35.02	Average	100	4	HORIZONTAL
2	4927.53	43.63	74.00	-30.37	42.03	3.35	33.26	35.01	Peak	100	4	HORIZONTAL
3	7388.40	35.60	54.00	-18.40	30.85	4.06	36.09	35.40	Average	135	129	HORIZONTAL
4	7393.05	52.71	74.00	-21.29	47.92	4.06	36.13	35.40	Peak	135	129	HORIZONTAL

Vertical

	Freq	Level	Limit Line	Over Limit	Read Level	CableAntenna Loss	Antenna Factor	Preamp Factor	Remark	A/Pos	T/Pos	Pol/Phase
	MHz	dBuV/m	dBuV/m	dB	dBuV	dB	dB/m	dB		cm	deg	
1	4918.39	30.49	54.00	-23.51	28.93	3.35	33.23	35.02	Average	100	304	VERTICAL
2	4920.51	43.47	74.00	-30.53	41.90	3.35	33.23	35.01	Peak	100	304	VERTICAL
3	7383.98	36.43	54.00	-17.57	31.68	4.06	36.09	35.40	Average	100	40	VERTICAL
4	7384.56	53.23	74.00	-20.77	48.48	4.06	36.09	35.40	Peak	100	40	VERTICAL

Temperature	25°C	Humidity	54%
Test Engineer	Kenneth Huang	Configurations	IEEE 802.11n MCS0 40MHz CH 3 / 1TX / Chain 1
Test Date	Aug. 13, 2013	Test Mode	Mode 1 (Ant.31 PIFA antenna / 4.4dBi)

Horizontal

	Freq	Level	Limit	Over	Read	Cable	Antenna	Preamp	Remark	A/Pos	T/Pos	Pol/Phase
	MHz	dBuV/m	dBuV/m	dB	dBuV	dB	dB/m	dB		cm	deg	
1	4840.73	42.83	74.00	-31.17	41.45	3.32	33.09	35.03	Peak	100	331	HORIZONTAL
2	4844.67	29.74	54.00	-24.26	28.36	3.32	33.09	35.03	Average	100	331	HORIZONTAL

Vertical

	Freq	Level	Limit	Over	Read	Cable	Antenna	Preamp	Remark	A/Pos	T/Pos	Pol/Phase
	MHz	dBuV/m	dBuV/m	dB	dBuV	dB	dB/m	dB		cm	deg	
1	4842.40	29.70	54.00	-24.30	28.32	3.32	33.09	35.03	Average	100	60	VERTICAL
2	4852.75	43.33	74.00	-30.67	41.95	3.32	33.09	35.03	Peak	100	60	VERTICAL

Temperature	25°C	Humidity	54%
Test Engineer	Kenneth Huang	Configurations	IEEE 802.11n MCS0 40MHz CH 6 / 1TX / Chain 1
Test Date	Aug. 13, 2013	Test Mode	Mode 1 (Ant.31 PIFA antenna / 4.4dBi)

Horizontal

	Freq	Level	Limit	Over	Read	CableAntenna	Preamp	Remark	A/Pos	T/Pos	Pol/Phase
	MHz	dBuV/m	dBuV/m	dB	dBuV	dB	dB/m	dB	cm	deg	
1	4878.30	43.08	74.00	-30.92	41.62	3.33	33.16	35.03	100	336	HORIZONTAL
2	4882.37	28.64	54.00	-25.36	27.18	3.33	33.16	35.03	100	336	HORIZONTAL
3	7301.83	53.62	74.00	-20.38	49.04	4.06	35.92	35.40	130	123	HORIZONTAL
4	7307.28	34.81	54.00	-19.19	30.23	4.06	35.92	35.40	130	123	HORIZONTAL

Vertical

	Freq	Level	Limit	Over	Read	CableAntenna	Preamp	Remark	A/Pos	T/Pos	Pol/Phase
	MHz	dBuV/m	dBuV/m	dB	dBuV	dB	dB/m	dB	cm	deg	
1	4878.84	42.77	74.00	-31.23	41.31	3.33	33.16	35.03	100	344	VERTICAL
2	4880.09	28.97	54.00	-25.03	27.51	3.33	33.16	35.03	100	344	VERTICAL
3	7301.77	54.31	74.00	-19.69	49.73	4.06	35.92	35.40	101	41	VERTICAL
4	7320.94	35.43	54.00	-18.57	30.81	4.06	35.96	35.40	101	41	VERTICAL

Temperature	25°C	Humidity	54%
Test Engineer	Kenneth Huang	Configurations	IEEE 802.11n MCS0 40MHz CH 9 / 1TX / Chain 1
Test Date	Aug. 13, 2013	Test Mode	Mode 1 (Ant.31 PIFA antenna / 4.4dBi)

Horizontal

	Freq	Level	Limit	Over	Read	CableAntenna	Preamp	Remark	A/Pos	T/Pos	Pol/Phase
	MHz	dBuV/m	dBuV/m	dB	dBuV	dB	dB/m	dB	cm	deg	
1	4904.80	43.69	74.00	-30.31	42.14	3.34	33.23	35.02	100	305	HORIZONTAL
2	4905.35	30.17	54.00	-23.83	28.62	3.34	33.23	35.02	100	305	HORIZONTAL
3	7348.60	33.70	54.00	-20.30	29.02	4.06	36.02	35.40	100	39	HORIZONTAL
4	7358.69	46.48	74.00	-27.52	41.76	4.06	36.06	35.40	100	39	HORIZONTAL

Vertical

	Freq	Level	Limit	Over	Read	CableAntenna	Preamp	Remark	A/Pos	T/Pos	Pol/Phase
	MHz	dBuV/m	dBuV/m	dB	dBuV	dB	dB/m	dB	cm	deg	
1	4901.98	43.02	74.00	-30.98	41.51	3.34	33.19	35.02	100	63	VERTICAL
2	4905.19	30.38	54.00	-23.62	28.83	3.34	33.23	35.02	100	63	VERTICAL
3	7351.80	33.90	54.00	-20.10	29.22	4.06	36.02	35.40	100	336	VERTICAL
4	7353.05	46.49	74.00	-27.51	41.81	4.06	36.02	35.40	100	336	VERTICAL

Temperature	25°C	Humidity	54%
Test Engineer	Jim Huang	Configurations	IEEE 802.11n MCS0 20MHz CH 1 / 2TX / Chain 1 + Chain 2
Test Date	Aug. 13, 2013	Test Mode	Mode 1 (Ant.31 PIFA antenna / 4.4dBi)

Horizontal

	Freq	Level	Limit Line	Over Limit	Read Level	CableAntenna Loss	Antenna Factor	Preamp Factor	Remark	A/Pos	T/Pos	Pol/Phase
	MHz	dBuV/m	dBuV/m	dB	dBuV	dB	dB/m	dB		cm	deg	
1	4816.37	43.86	74.00	-30.14	42.57	3.31	33.02	35.04	Peak	100	199	HORIZONTAL
2	4820.73	30.32	54.00	-23.68	28.98	3.31	33.06	35.03	Average	100	199	HORIZONTAL

Vertical

	Freq	Level	Limit Line	Over Limit	Read Level	CableAntenna Loss	Antenna Factor	Preamp Factor	Remark	A/Pos	T/Pos	Pol/Phase
	MHz	dBuV/m	dBuV/m	dB	dBuV	dB	dB/m	dB		cm	deg	
1	4818.01	42.58	74.00	-31.42	41.28	3.31	33.02	35.03	Peak	100	287	VERTICAL
2	4820.54	30.77	54.00	-23.23	29.43	3.31	33.06	35.03	Average	100	287	VERTICAL

Temperature	25°C	Humidity	54%
Test Engineer	Jim Huang	Configurations	IEEE 802.11n MCS0 20MHz CH 6 / 2TX / Chain 1 + Chain 2
Test Date	Aug. 13, 2013	Test Mode	Mode 1 (Ant.31 PIFA antenna / 4.4dBi)

Horizontal

	Freq	Level	Limit	Over	Read	CableAntenna	Preamp	Remark	A/Pos	T/Pos	Pol/Phase	
	MHz	dBuV/m	dBuV/m	dB	dBuV	dB	dB/m	dB	cm	deg		
1	4867.80	46.15	74.00	-27.85	44.73	3.33	33.12	35.03	Peak	100	276	HORIZONTAL
2	4869.48	33.38	54.00	-20.62	31.96	3.33	33.12	35.03	Average	100	276	HORIZONTAL
3	7305.90	63.33	74.00	-10.67	58.75	4.06	35.92	35.40	Peak	148	104	HORIZONTAL
4	7307.20	46.41	54.00	-7.59	41.83	4.06	35.92	35.40	Average	148	104	HORIZONTAL

Vertical

	Freq	Level	Limit	Over	Read	CableAntenna	Preamp	Remark	A/Pos	T/Pos	Pol/Phase	
	MHz	dBuV/m	dBuV/m	dB	dBuV	dB	dB/m	dB	cm	deg		
1	4868.86	46.68	74.00	-27.32	45.26	3.33	33.12	35.03	Peak	100	218	VERTICAL
2	4870.97	33.63	54.00	-20.37	32.17	3.33	33.16	35.03	Average	100	218	VERTICAL
3	7316.24	45.36	54.00	-8.64	40.74	4.06	35.96	35.40	Average	100	43	VERTICAL
4	7318.64	62.50	74.00	-11.50	57.88	4.06	35.96	35.40	Peak	100	43	VERTICAL

Temperature	25°C	Humidity	54%
Test Engineer	Jim Huang	Configurations	IEEE 802.11n MCS0 20MHz CH 11 / 2TX / Chain 1 + Chain 2
Test Date	Aug. 13, 2013	Test Mode	Mode 1 (Ant.31 PIFA antenna / 4.4dBi)

Horizontal

	Freq	Level	Limit Line	Over Limit	Read Level	CableAntenna Loss	Antenna Factor	Preamp Factor	Remark	A/Pos	T/Pos	Pol/Phase
	MHz	dBuV/m	dBuV/m	dB	dBuV	dB	dB/m	dB		cm	deg	
1	4915.92	42.48	74.00	-31.52	40.92	3.35	33.23	35.02	Peak	100	256	HORIZONTAL
2	4918.58	30.23	54.00	-23.77	28.67	3.35	33.23	35.02	Average	100	256	HORIZONTAL
3	7383.15	35.10	54.00	-18.90	30.35	4.06	36.09	35.40	Average	100	141	HORIZONTAL
4	7386.19	50.06	74.00	-23.94	45.31	4.06	36.09	35.40	Peak	100	141	HORIZONTAL

Vertical

	Freq	Level	Limit Line	Over Limit	Read Level	CableAntenna Loss	Antenna Factor	Preamp Factor	Remark	A/Pos	T/Pos	Pol/Phase
	MHz	dBuV/m	dBuV/m	dB	dBuV	dB	dB/m	dB		cm	deg	
1	4917.85	42.58	74.00	-31.42	41.02	3.35	33.23	35.02	Peak	100	264	VERTICAL
2	4919.48	30.94	54.00	-23.06	29.38	3.35	33.23	35.02	Average	100	264	VERTICAL
3	7380.71	46.49	74.00	-27.51	41.74	4.06	36.09	35.40	Peak	100	118	VERTICAL
4	7383.95	33.65	54.00	-20.35	28.90	4.06	36.09	35.40	Average	100	118	VERTICAL

Temperature	25°C	Humidity	54%
Test Engineer	Jim Huang	Configurations	IEEE 802.11n MCS0 40MHz CH 3 / 2TX / Chain 1 + Chain 2
Test Date	Aug. 13, 2013	Test Mode	Mode 1 (Ant.31 PIFA antenna / 4.4dBi)

Horizontal

	Freq	Level	Limit	Over	Read	Cable	Antenna	Preamp	Remark	A/Pos	T/Pos	Pol/Phase
	MHz	dBuV/m	dBuV/m	dB	dBuV	Loss	Factor	Factor		cm	deg	
1	4844.22	29.86	54.00	-24.14	28.48	3.32	33.09	35.03	Average	100	76	HORIZONTAL
2	4850.64	43.48	74.00	-30.52	42.10	3.32	33.09	35.03	Peak	100	76	HORIZONTAL

Vertical

	Freq	Level	Limit	Over	Read	Cable	Antenna	Preamp	Remark	A/Pos	T/Pos	Pol/Phase
	MHz	dBuV/m	dBuV/m	dB	dBuV	Loss	Factor	Factor		cm	deg	
1	4844.55	30.03	54.00	-23.97	28.65	3.32	33.09	35.03	Average	100	305	VERTICAL
2	4845.51	42.77	74.00	-31.23	41.39	3.32	33.09	35.03	Peak	100	305	VERTICAL

Temperature	25°C	Humidity	54%
Test Engineer	Jim Huang	Configurations	IEEE 802.11n MCS0 40MHz CH 6 / 2TX / Chain 1 + Chain 2
Test Date	Aug. 13, 2013	Test Mode	Mode 1 (Ant.31 PIFA antenna / 4.4dBi)

Horizontal

	Freq	Level	Limit	Over	Read	CableAntenna	Preamp	Remark	A/Pos	T/Pos	Pol/Phase
	MHz	dBuV/m	dBuV/m	dB	dBuV	dB	dB/m	dB	cm	deg	
1	4869.90	29.79	54.00	-24.21	28.37	3.33	33.12	35.03	Average	100	175 HORIZONTAL
2	4882.17	43.34	74.00	-30.66	41.88	3.33	33.16	35.03	Peak	100	175 HORIZONTAL
3	7307.64	33.94	54.00	-20.06	29.32	4.06	35.96	35.40	Average	100	159 HORIZONTAL
4	7314.72	49.26	74.00	-24.74	44.64	4.06	35.96	35.40	Peak	100	159 HORIZONTAL

Vertical

	Freq	Level	Limit	Over	Read	CableAntenna	Preamp	Remark	A/Pos	T/Pos	Pol/Phase
	MHz	dBuV/m	dBuV/m	dB	dBuV	dB	dB/m	dB	cm	deg	
1	4880.83	29.91	54.00	-24.09	28.45	3.33	33.16	35.03	Average	100	184 VERTICAL
2	4883.23	42.57	74.00	-31.43	41.11	3.33	33.16	35.03	Peak	100	184 VERTICAL
3	7302.99	46.02	74.00	-27.98	41.44	4.06	35.92	35.40	Peak	100	279 VERTICAL
4	7310.39	33.33	54.00	-20.67	28.71	4.06	35.96	35.40	Average	100	279 VERTICAL

Temperature	25°C	Humidity	54%
Test Engineer	Jim Huang	Configurations	IEEE 802.11n MCS0 40MHz CH 9 / 2TX / Chain 1 + Chain 2
Test Date	Aug. 13, 2013	Test Mode	Mode 1 (Ant.31 PIFA antenna / 4.4dBi)

Horizontal

	Freq	Level	Limit	Over	Read	CableAntenna	Preamp	Remark	A/Pos	T/Pos	Pol/Phase
	MHz	dBuV/m	dBuV/m	dB	dBuV	dB	dB/m	dB	cm	deg	
1	4896.21	43.41	74.00	-30.59	41.90	3.34	33.19	35.02	100	150	HORIZONTAL
2	4913.33	30.26	54.00	-23.74	28.71	3.34	33.23	35.02	100	150	HORIZONTAL
3	7346.87	33.57	54.00	-20.43	28.89	4.06	36.02	35.40	100	317	HORIZONTAL
4	7352.70	46.57	74.00	-27.43	41.89	4.06	36.02	35.40	100	317	HORIZONTAL

Vertical

	Freq	Level	Limit	Over	Read	CableAntenna	Preamp	Remark	A/Pos	T/Pos	Pol/Phase
	MHz	dBuV/m	dBuV/m	dB	dBuV	dB	dB/m	dB	cm	deg	
1	4909.90	42.73	74.00	-31.27	41.18	3.34	33.23	35.02	100	39	VERTICAL
2	4913.74	30.23	54.00	-23.77	28.68	3.34	33.23	35.02	100	39	VERTICAL
3	7348.24	33.68	54.00	-20.32	29.00	4.06	36.02	35.40	100	174	VERTICAL
4	7351.96	46.00	74.00	-28.00	41.32	4.06	36.02	35.40	100	174	VERTICAL

Temperature	25°C	Humidity	54%
Test Engineer	Jim Huang	Configurations	IEEE 802.11n MCS0 20MHz CH 1 / 3TX / Chain 1 + Chain 2 + Chain 3
Test Date	Aug. 09, 2013	Test Mode	Mode 1 (Ant.31 PIFA antenna / 4.4dBi)

Horizontal

	Freq	Level	Limit	Over	Read	Cable	Antenna	Preamp	Remark	A/Pos	T/Pos	Pol/Phase
	MHz	dBuV/m	dBuV/m	dB	dBuV	Loss	Factor	Factor		cm	deg	
1	4823.76	34.80	54.00	-19.20	33.46	3.31	33.06	35.03	Average	171	47	HORIZONTAL
2	4824.12	49.57	74.00	-24.43	48.23	3.31	33.06	35.03	Peak	171	47	HORIZONTAL

Vertical

	Freq	Level	Limit	Over	Read	Cable	Antenna	Preamp	Remark	A/Pos	T/Pos	Pol/Phase
	MHz	dBuV/m	dBuV/m	dB	dBuV	Loss	Factor	Factor		cm	deg	
1	4823.80	36.03	54.00	-17.97	34.69	3.31	33.06	35.03	Average	100	69	VERTICAL
2	4824.00	51.41	74.00	-22.59	50.07	3.31	33.06	35.03	Peak	100	69	VERTICAL

Temperature	25°C	Humidity	54%
Test Engineer	Jim Huang	Configurations	IEEE 802.11n MCS0 20MHz CH 6 / 3TX / Chain 1 + Chain 2 + Chain 3
Test Date	Aug. 09, 2013	Test Mode	Mode 1 (Ant.31 PIFA antenna / 4.4dBi)

Horizontal

	Freq	Level	Limit	Over	Read	CableAntenna	Preamp	Remark	A/Pos	T/Pos	Pol/Phase
	MHz	dBuV/m	dBuV/m	dB	dBuV	dB	dB/m	dB	cm	deg	
1	4871.66	50.38	74.00	-23.62	48.92	3.33	33.16	35.03	Peak	145	31 HORIZONTAL
2	4872.86	33.83	54.00	-20.17	32.37	3.33	33.16	35.03	Average	145	31 HORIZONTAL
3	7312.08	68.27	74.00	-5.73	63.65	4.06	35.96	35.40	Peak	159	226 HORIZONTAL
4	7312.68	37.90	54.00	-16.10	33.28	4.06	35.96	35.40	Average	159	226 HORIZONTAL

Vertical

	Freq	Level	Limit	Over	Read	CableAntenna	Preamp	Remark	A/Pos	T/Pos	Pol/Phase
	MHz	dBuV/m	dBuV/m	dB	dBuV	dB	dB/m	dB	cm	deg	
1	4872.38	51.77	74.00	-22.23	50.31	3.33	33.16	35.03	Peak	100	73 VERTICAL
2	4872.98	34.33	54.00	-19.67	32.87	3.33	33.16	35.03	Average	100	73 VERTICAL
3	7312.44	70.43	74.00	-3.57	65.81	4.06	35.96	35.40	Peak	100	238 VERTICAL
4	7318.92	37.02	54.00	-16.98	32.40	4.06	35.96	35.40	Average	100	238 VERTICAL

Temperature	25°C	Humidity	54%
Test Engineer	Jim Huang	Configurations	IEEE 802.11n MCS0 20MHz CH 11 / 3TX / Chain 1 + Chain 2 + Chain 3
Test Date	Aug. 09, 2013	Test Mode	Mode 1 (Ant.31 PIFA antenna / 4.4dBi)

Horizontal

	Freq	Level	Limit Line	Over Limit	Read Level	CableAntenna Loss	Antenna Factor	Preamp Factor	Remark	A/Pos	T/Pos	Pol/Phase
	MHz	dBuV/m	dBuV/m	dB	dBuV	dB	dB/m	dB		cm	deg	
1	4923.88	32.44	54.00	-21.56	30.84	3.35	33.26	35.01	Average	163	44	HORIZONTAL
2	4924.12	45.69	74.00	-28.31	44.09	3.35	33.26	35.01	Peak	163	44	HORIZONTAL
3	7386.48	70.78	74.00	-3.22	66.03	4.06	36.09	35.40	Peak	167	307	HORIZONTAL
4	7392.90	37.46	54.00	-16.54	32.67	4.06	36.13	35.40	Average	167	307	HORIZONTAL

Vertical

	Freq	Level	Limit Line	Over Limit	Read Level	CableAntenna Loss	Antenna Factor	Preamp Factor	Remark	A/Pos	T/Pos	Pol/Phase
	MHz	dBuV/m	dBuV/m	dB	dBuV	dB	dB/m	dB		cm	deg	
1	4923.52	48.03	74.00	-25.97	46.43	3.35	33.26	35.01	Peak	125	73	VERTICAL
2	4923.58	34.57	54.00	-19.43	32.97	3.35	33.26	35.01	Average	125	73	VERTICAL
3	7382.70	37.05	54.00	-16.95	32.30	4.06	36.09	35.40	Average	100	238	VERTICAL
4	7386.66	70.79	74.00	-3.21	66.04	4.06	36.09	35.40	Peak	100	238	VERTICAL

Temperature	25°C	Humidity	54%
Test Engineer	Jim Huang	Configurations	IEEE 802.11n MCS0 40MHz CH 3 / 3TX / Chain 1 + Chain 2 + Chain 3
Test Date	Aug. 10, 2013	Test Mode	Mode 1 (Ant.31 PIFA antenna / 4.4dBi)

Horizontal

	Freq	Level	Limit Line	Over Limit	Read Level	CableAntenna Loss Factor	Preamp Factor	Remark	A/Pos	T/Pos	Pol/Phase
	MHz	dBuV/m	dBuV/m	dB	dBuV	dB	dB/m	dB	cm	deg	
1	4826.80	30.34	54.00	-23.66	29.00	3.31	33.06	35.03	Average	100	262 HORIZONTAL
2	4826.80	39.48	74.00	-34.52	38.14	3.31	33.06	35.03	Peak	100	262 HORIZONTAL
3	7274.24	33.48	54.00	-20.52	28.93	4.06	35.89	35.40	Average	100	118 HORIZONTAL
4	7274.72	45.76	74.00	-28.24	41.21	4.06	35.89	35.40	Peak	100	118 HORIZONTAL

Vertical

	Freq	Level	Limit Line	Over Limit	Read Level	CableAntenna Loss Factor	Preamp Factor	Remark	A/Pos	T/Pos	Pol/Phase
	MHz	dBuV/m	dBuV/m	dB	dBuV	dB	dB/m	dB	cm	deg	
1	4844.64	31.52	54.00	-22.48	30.14	3.32	33.09	35.03	Average	100	178 VERTICAL
2	4855.76	43.28	74.00	-30.72	41.87	3.32	33.12	35.03	Peak	100	178 VERTICAL
3	7270.48	55.06	74.00	-18.94	50.55	4.06	35.85	35.40	Peak	100	231 VERTICAL
4	7271.92	33.63	54.00	-20.37	29.12	4.06	35.85	35.40	Average	100	231 VERTICAL

Temperature	25°C	Humidity	54%
Test Engineer	Jim Huang	Configurations	IEEE 802.11n MCS0 40MHz CH 6 / 3TX / Chain 1 + Chain 2 + Chain 3
Test Date	Aug. 10, 2013	Test Mode	Mode 1 (Ant.31 PIFA antenna / 4.4dBi)

Horizontal

	Freq	Level	Limit Line	Over Limit	Read Level	CableAntenna Loss	Antenna Factor	Preamp Factor	Remark	A/Pos	T/Pos	Pol/Phase
	MHz	dBuV/m	dBuV/m	dB	dBuV	dB	dB/m	dB		cm	deg	
1	4867.04	47.87	74.00	-26.13	46.45	3.33	33.12	35.03	Peak	100	30	HORIZONTAL
2	4873.88	33.92	54.00	-20.08	32.46	3.33	33.16	35.03	Average	100	30	HORIZONTAL
3	7312.80	39.60	54.00	-14.40	34.98	4.06	35.96	35.40	Average	161	302	HORIZONTAL
4	7327.80	68.96	74.00	-5.04	64.31	4.06	35.99	35.40	Peak	161	302	HORIZONTAL

Vertical

	Freq	Level	Limit Line	Over Limit	Read Level	CableAntenna Loss	Antenna Factor	Preamp Factor	Remark	A/Pos	T/Pos	Pol/Phase
	MHz	dBuV/m	dBuV/m	dB	dBuV	dB	dB/m	dB		cm	deg	
1	4867.04	50.68	74.00	-23.32	49.26	3.33	33.12	35.03	Peak	100	2	VERTICAL
2	4872.68	34.00	54.00	-20.00	32.54	3.33	33.16	35.03	Average	100	2	VERTICAL
3	7327.80	70.29	74.00	-3.71	65.64	4.06	35.99	35.40	Peak	124	227	VERTICAL
4	7328.52	39.14	54.00	-14.86	34.49	4.06	35.99	35.40	Average	124	227	VERTICAL

Temperature	25°C	Humidity	54%
Test Engineer	Jim Huang	Configurations	IEEE 802.11n MCS0 40MHz CH 9 / 3TX / Chain 1 + Chain 2 + Chain 3
Test Date	Aug. 10, 2013	Test Mode	Mode 1 (Ant.31 PIFA antenna / 4.4dBi)

Horizontal

	Freq	Level	Limit	Over	Read	CableAntenna	Preamp	Remark	A/Pos	T/Pos	Pol/Phase
	MHz	dBuV/m	dBuV/m	dB	dBuV	dB	dB/m	dB	cm	deg	
1	4904.96	30.55	54.00	-23.45	29.00	3.34	33.23	35.02	Average	100	53 HORIZONTAL
2	4905.32	43.29	74.00	-30.71	41.74	3.34	33.23	35.02	Peak	100	53 HORIZONTAL
3	7368.96	33.41	54.00	-20.59	28.69	4.06	36.06	35.40	Average	100	153 HORIZONTAL
4	7374.60	50.75	74.00	-23.25	46.03	4.06	36.06	35.40	Peak	100	153 HORIZONTAL

Vertical

	Freq	Level	Limit	Over	Read	CableAntenna	Preamp	Remark	A/Pos	T/Pos	Pol/Phase
	MHz	dBuV/m	dBuV/m	dB	dBuV	dB	dB/m	dB	cm	deg	
1	4904.12	31.10	54.00	-22.90	29.59	3.34	33.19	35.02	Average	100	91 VERTICAL
2	4925.24	43.06	74.00	-30.94	41.46	3.35	33.26	35.01	Peak	100	91 VERTICAL
3	7351.92	54.08	74.00	-19.92	49.40	4.06	36.02	35.40	Peak	100	320 VERTICAL
4	7352.52	33.87	54.00	-20.13	29.19	4.06	36.02	35.40	Average	100	320 VERTICAL

Temperature	25°C	Humidity	54%
Test Engineer	Jim Huang	Configurations	IEEE 802.11n MCS8 20MHz CH 1 / 2TX / Chain 1 + Chain 2
Test Date	Aug. 13, 2013	Test Mode	Mode 1 (Ant.31 PIFA antenna / 4.4dBi)

Horizontal

	Freq	Level	Limit Line	Over Limit	Read Level	CableAntenna Loss	Antenna Factor	Preamp Factor	Remark	A/Pos	T/Pos	Pol/Phase
	MHz	dBuV/m	dBuV/m	dB	dBuV	dB	dB/m	dB		cm	deg	
1	4815.70	43.83	74.00	-30.17	42.54	3.31	33.02	35.04	Peak	100	151	HORIZONTAL
2	4822.43	30.90	54.00	-23.10	29.56	3.31	33.06	35.03	Average	100	151	HORIZONTAL

Vertical

	Freq	Level	Limit Line	Over Limit	Read Level	CableAntenna Loss	Antenna Factor	Preamp Factor	Remark	A/Pos	T/Pos	Pol/Phase
	MHz	dBuV/m	dBuV/m	dB	dBuV	dB	dB/m	dB		cm	deg	
1	4822.94	43.56	74.00	-30.44	42.22	3.31	33.06	35.03	Peak	100	246	VERTICAL
2	4822.97	31.08	54.00	-22.92	29.74	3.31	33.06	35.03	Average	100	246	VERTICAL

Temperature	25°C	Humidity	54%
Test Engineer	Kenneth Huang	Configurations	IEEE 802.11n MCS8 20MHz CH 6 / 2TX / Chain 1 + Chain 2
Test Date	Aug. 13, 2013	Test Mode	Mode 1 (Ant.31 PIFA antenna / 4.4dBi)

Horizontal

	Freq	Level	Limit	Over	Read	CableAntenna	Preamp	Remark	A/Pos	T/Pos	Pol/Phase
	MHz	dBuV/m	dBuV/m	dB	dBuV	dB	dB/m	dB	cm	deg	
1	4874.00	46.09	74.00	-27.91	44.63	3.33	33.16	35.03	Peak	100	165 HORIZONTAL
2	4874.51	31.18	54.00	-22.82	29.72	3.33	33.16	35.03	Average	100	165 HORIZONTAL
3	7316.39	43.15	54.00	-10.85	38.53	4.06	35.96	35.40	Average	150	112 HORIZONTAL
4	7317.86	60.00	74.00	-14.00	55.38	4.06	35.96	35.40	Peak	150	112 HORIZONTAL

Vertical

	Freq	Level	Limit	Over	Read	CableAntenna	Preamp	Remark	A/Pos	T/Pos	Pol/Phase
	MHz	dBuV/m	dBuV/m	dB	dBuV	dB	dB/m	dB	cm	deg	
1	4874.06	49.24	74.00	-24.76	47.78	3.33	33.16	35.03	Peak	100	147 VERTICAL
2	4874.42	31.93	54.00	-22.07	30.47	3.33	33.16	35.03	Average	100	147 VERTICAL
3	7314.88	43.27	54.00	-10.73	38.65	4.06	35.96	35.40	Average	100	56 VERTICAL
4	7316.42	60.78	74.00	-13.22	56.16	4.06	35.96	35.40	Peak	100	56 VERTICAL

Temperature	25°C	Humidity	54%
Test Engineer	Jim Huang	Configurations	IEEE 802.11n MCS8 20MHz CH 11 / 2TX / Chain 1 + Chain 2
Test Date	Aug. 13, 2013	Test Mode	Mode 1 (Ant.31 PIFA antenna / 4.4dBi)

Horizontal

	Freq	Level	Limit Line	Over Limit	Read Level	CableAntenna Loss	Antenna Factor	Preamp Factor	Remark	A/Pos	T/Pos	Pol/Phase
	MHz	dBuV/m	dBuV/m	dB	dBuV	dB	dB/m	dB		cm	deg	
1	4919.99	30.62	54.00	-23.38	29.05	3.35	33.23	35.01	Average	100	218	HORIZONTAL
2	4933.78	42.48	74.00	-31.52	40.88	3.35	33.26	35.01	Peak	100	218	HORIZONTAL
3	7382.47	48.05	74.00	-25.95	43.30	4.06	36.09	35.40	Peak	100	106	HORIZONTAL
4	7385.39	34.41	54.00	-19.59	29.66	4.06	36.09	35.40	Average	100	106	HORIZONTAL

Vertical

	Freq	Level	Limit Line	Over Limit	Read Level	CableAntenna Loss	Antenna Factor	Preamp Factor	Remark	A/Pos	T/Pos	Pol/Phase
	MHz	dBuV/m	dBuV/m	dB	dBuV	dB	dB/m	dB		cm	deg	
1	4921.98	42.97	74.00	-31.03	41.37	3.35	33.26	35.01	Peak	100	319	VERTICAL
2	4924.58	30.97	54.00	-23.03	29.37	3.35	33.26	35.01	Average	100	319	VERTICAL
3	7379.88	49.88	74.00	-24.12	45.13	4.06	36.09	35.40	Peak	100	42	VERTICAL
4	7384.78	35.70	54.00	-18.30	30.95	4.06	36.09	35.40	Average	100	42	VERTICAL

Temperature	25°C	Humidity	54%
Test Engineer	Jim Huang	Configurations	IEEE 802.11n MCS8 40MHz CH 3 / 2TX / Chain 1 + Chain 2
Test Date	Aug. 13, 2013	Test Mode	Mode 1 (Ant.31 PIFA antenna / 4.4dBi)

Horizontal

	Freq	Level	Limit Line	Over Limit	Read Level	CableAntenna Loss	Antenna Factor	Preamp Factor	Remark	A/Pos	T/Pos	Pol/Phase
	MHz	dBuV/m	dBuV/m	dB	dBuV	dB	dB/m	dB		cm	deg	
1	4844.96	43.02	74.00	-30.98	41.64	3.32	33.09	35.03	Peak	100	150	HORIZONTAL
2	4853.65	30.16	54.00	-23.84	28.75	3.32	33.12	35.03	Average	100	150	HORIZONTAL

Vertical

	Freq	Level	Limit Line	Over Limit	Read Level	CableAntenna Loss	Antenna Factor	Preamp Factor	Remark	A/Pos	T/Pos	Pol/Phase
	MHz	dBuV/m	dBuV/m	dB	dBuV	dB	dB/m	dB		cm	deg	
1	4844.32	30.01	54.00	-23.99	28.63	3.32	33.09	35.03	Average	100	296	VERTICAL
2	4852.91	43.88	74.00	-30.12	42.50	3.32	33.09	35.03	Peak	100	296	VERTICAL

Temperature	25°C	Humidity	54%
Test Engineer	Jim Huang	Configurations	IEEE 802.11n MCS8 40MHz CH 6 / 2TX / Chain 1 + Chain 2
Test Date	Aug. 13, 2013	Test Mode	Mode 1 (Ant.31 PIFA antenna / 4.4dBi)

Horizontal

	Freq	Level	Limit Line	Over Limit	Read Level	CableAntenna Loss	Antenna Factor	Preamp Factor	Remark	A/Pos	T/Pos	Pol/Phase
	MHz	dBuV/m	dBuV/m	dB	dBuV	dB	dB/m	dB		cm	deg	
1	4865.15	42.55	74.00	-31.45	41.13	3.33	33.12	35.03	Peak	100	81	HORIZONTAL
2	4878.49	29.61	54.00	-24.39	28.15	3.33	33.16	35.03	Average	100	81	HORIZONTAL
3	7314.59	35.13	54.00	-18.87	30.51	4.06	35.96	35.40	Average	100	143	HORIZONTAL
4	7319.88	49.04	74.00	-24.96	44.42	4.06	35.96	35.40	Peak	100	143	HORIZONTAL

Vertical

	Freq	Level	Limit Line	Over Limit	Read Level	CableAntenna Loss	Antenna Factor	Preamp Factor	Remark	A/Pos	T/Pos	Pol/Phase
	MHz	dBuV/m	dBuV/m	dB	dBuV	dB	dB/m	dB		cm	deg	
1	4875.47	42.89	74.00	-31.11	41.43	3.33	33.16	35.03	Peak	100	94	VERTICAL
2	4882.69	30.02	54.00	-23.98	28.56	3.33	33.16	35.03	Average	100	94	VERTICAL
3	7306.19	46.21	74.00	-27.79	41.63	4.06	35.92	35.40	Peak	100	302	VERTICAL
4	7309.81	33.43	54.00	-20.57	28.81	4.06	35.96	35.40	Average	100	302	VERTICAL

Temperature	25°C	Humidity	54%
Test Engineer	Jim Huang	Configurations	IEEE 802.11n MCS8 40MHz CH 9 / 2TX / Chain 1 + Chain 2
Test Date	Aug. 13, 2013	Test Mode	Mode 1 (Ant.31 PIFA antenna / 4.4dBi)

Horizontal

	Freq	Level	Limit	Over	Read	CableAntenna	Preamp	Remark	A/Pos	T/Pos	Pol/Phase
	MHz	dBuV/m	dBuV/m	dB	dBuV	dB	dB/m	dB	cm	deg	
1	4894.96	42.56	74.00	-31.44	41.05	3.34	33.19	35.02	Peak	100	254 HORIZONTAL
2	4904.90	30.07	54.00	-23.93	28.52	3.34	33.23	35.02	Average	100	254 HORIZONTAL
3	7347.70	33.66	54.00	-20.34	28.98	4.06	36.02	35.40	Average	100	335 HORIZONTAL
4	7365.49	46.28	74.00	-27.72	41.56	4.06	36.06	35.40	Peak	100	335 HORIZONTAL

Vertical

	Freq	Level	Limit	Over	Read	CableAntenna	Preamp	Remark	A/Pos	T/Pos	Pol/Phase
	MHz	dBuV/m	dBuV/m	dB	dBuV	dB	dB/m	dB	cm	deg	
1	4906.89	30.12	54.00	-23.88	28.57	3.34	33.23	35.02	Average	100	96 VERTICAL
2	4912.05	43.27	74.00	-30.73	41.72	3.34	33.23	35.02	Peak	100	96 VERTICAL
3	7350.42	33.52	54.00	-20.48	28.84	4.06	36.02	35.40	Average	100	223 VERTICAL
4	7360.81	45.79	74.00	-28.21	41.07	4.06	36.06	35.40	Peak	100	223 VERTICAL

Temperature	25°C	Humidity	54%
Test Engineer	Jim Huang	Configurations	IEEE 802.11n MCS8 20MHz CH 1 / 3TX / Chain 1 + Chain 2 + Chain 3
Test Date	Aug. 10, 2013	Test Mode	Mode 1 (Ant.31 PIFA antenna / 4.4dBi)

Horizontal

	Freq	Level	Limit Line	Over Limit	Read Level	Cable Loss	Antenna Factor	Preamp Factor	Remark	A/Pos	T/Pos	Pol/Phase
	MHz	dBuV/m	dBuV/m	dB	dBuV	dB	dB/m	dB		cm	deg	
1	4818.24	45.30	74.00	-28.70	44.00	3.31	33.02	35.03	Peak	100	39	HORIZONTAL
2	4828.24	33.62	54.00	-20.38	32.28	3.31	33.06	35.03	Average	100	39	HORIZONTAL

Vertical

	Freq	Level	Limit Line	Over Limit	Read Level	Cable Loss	Antenna Factor	Preamp Factor	Remark	A/Pos	T/Pos	Pol/Phase
	MHz	dBuV/m	dBuV/m	dB	dBuV	dB	dB/m	dB		cm	deg	
1	4822.80	48.43	74.00	-25.57	47.09	3.31	33.06	35.03	Peak	125	74	VERTICAL
2	4823.92	34.86	54.00	-19.14	33.52	3.31	33.06	35.03	Average	125	74	VERTICAL

Temperature	25°C	Humidity	54%
Test Engineer	Jim Huang	Configurations	IEEE 802.11n MCS8 20MHz CH 6 / 3TX / Chain 1 + Chain 2 + Chain 3
Test Date	Aug. 10, 2013	Test Mode	Mode 1 (Ant.31 PIFA antenna / 4.4dBi)

Horizontal

	Freq	Level	Limit Line	Over Limit	Read Level	CableAntenna Loss Factor	Preamp Factor	Remark	A/Pos	T/Pos	Pol/Phase
	MHz	dBuV/m	dBuV/m	dB	dBuV	dB	dB/m	dB	cm	deg	
1	4863.20	42.51	74.00	-31.49	41.10	3.32	33.12	35.03	Peak	100	223 HORIZONTAL
2	4875.10	31.35	54.00	-22.65	29.89	3.33	33.16	35.03	Average	100	223 HORIZONTAL
3	7306.10	62.95	74.00	-11.05	58.37	4.06	35.92	35.40	Peak	100	227 HORIZONTAL
4	7309.30	36.77	54.00	-17.23	32.15	4.06	35.96	35.40	Average	100	227 HORIZONTAL

Vertical

	Freq	Level	Limit Line	Over Limit	Read Level	CableAntenna Loss Factor	Preamp Factor	Remark	A/Pos	T/Pos	Pol/Phase
	MHz	dBuV/m	dBuV/m	dB	dBuV	dB	dB/m	dB	cm	deg	
1	4868.00	47.06	74.00	-26.94	45.64	3.33	33.12	35.03	Peak	100	10 VERTICAL
2	4870.40	34.05	54.00	-19.95	32.63	3.33	33.12	35.03	Average	100	10 VERTICAL
3	7306.90	70.61	74.00	-3.39	66.03	4.06	35.92	35.40	Peak	100	254 VERTICAL
4	7315.50	39.23	54.00	-14.77	34.61	4.06	35.96	35.40	Average	100	254 VERTICAL

Temperature	25°C	Humidity	54%
Test Engineer	Jim Huang	Configurations	IEEE 802.11n MCS8 20MHz CH 11 / 3TX / Chain 1 + Chain 2 + Chain 3
Test Date	Aug. 10, 2013	Test Mode	Mode 1 (Ant.31 PIFA antenna / 4.4dBi)

Horizontal

	Freq	Level	Limit	Over	Read	CableAntenna	Preamp	Remark	A/Pos	T/Pos	Pol/Phase
	MHz	dBuV/m	dBuV/m	dB	dBuV	dB	dB/m	dB	cm	deg	
1	4922.38	30.91	54.00	-23.09	29.31	3.35	33.26	35.01	Average	100	249 HORIZONTAL
2	4924.42	42.90	74.00	-31.10	41.30	3.35	33.26	35.01	Peak	100	249 HORIZONTAL
3	7380.72	59.96	74.00	-14.04	55.21	4.06	36.09	35.40	Peak	100	201 HORIZONTAL
4	7397.04	33.51	54.00	-20.49	28.72	4.06	36.13	35.40	Average	100	201 HORIZONTAL

Vertical

	Freq	Level	Limit	Over	Read	CableAntenna	Preamp	Remark	A/Pos	T/Pos	Pol/Phase
	MHz	dBuV/m	dBuV/m	dB	dBuV	dB	dB/m	dB	cm	deg	
1	4913.68	44.64	74.00	-29.36	43.09	3.34	33.23	35.02	Peak	100	125 VERTICAL
2	4919.50	31.76	54.00	-22.24	30.20	3.35	33.23	35.02	Average	100	125 VERTICAL
3	7381.68	70.87	74.00	-3.13	66.12	4.06	36.09	35.40	Peak	114	226 VERTICAL
4	7388.24	36.44	54.00	-17.56	31.69	4.06	36.09	35.40	Average	114	226 VERTICAL

Temperature	25°C	Humidity	54%
Test Engineer	Jim Huang	Configurations	IEEE 802.11n MCS8 40MHz CH 3 / 3TX / Chain 1 + Chain 2 + Chain 3
Test Date	Aug. 10, 2013	Test Mode	Mode 1 (Ant.31 PIFA antenna / 4.4dBi)

Horizontal

	Freq	Level	Limit	Over	Read	Cable	Antenna	Preamp	Remark	A/Pos	T/Pos	Pol/Phase
	MHz	dBuV/m	dBuV/m	dB	dBuV	dB	dB/m	dB		cm	deg	
1	4850.56	43.01	74.00	-30.99	41.63	3.32	33.09	35.03	Peak	100	323	HORIZONTAL
2	4852.40	30.57	54.00	-23.43	29.19	3.32	33.09	35.03	Average	100	323	HORIZONTAL

Vertical

	Freq	Level	Limit	Over	Read	Cable	Antenna	Preamp	Remark	A/Pos	T/Pos	Pol/Phase
	MHz	dBuV/m	dBuV/m	dB	dBuV	dB	dB/m	dB		cm	deg	
1	4828.80	31.06	54.00	-22.94	29.72	3.31	33.06	35.03	Average	100	231	VERTICAL
2	4848.80	43.64	74.00	-30.36	42.26	3.32	33.09	35.03	Peak	100	231	VERTICAL

Temperature	25°C	Humidity	54%
Test Engineer	Jim Huang	Configurations	IEEE 802.11n MCS8 40MHz CH 6 / 3TX / Chain 1 + Chain 2 + Chain 3
Test Date	Aug. 10, 2013	Test Mode	Mode 1 (Ant.31 PIFA antenna / 4.4dBi)

Horizontal

	Freq	Level	Limit	Over	Read	CableAntenna	Preamp	Remark	A/Pos	T/Pos	Pol/Phase
	MHz	dBuV/m	dBuV/m	dB	dBuV	dB	dB/m	dB	cm	deg	
1	4878.86	31.01	54.00	-22.99	29.55	3.33	33.16	35.03	Average	100	252 HORIZONTAL
2	4880.54	42.77	74.00	-31.23	41.31	3.33	33.16	35.03	Peak	100	252 HORIZONTAL
3	7294.40	53.85	74.00	-20.15	49.27	4.06	35.92	35.40	Peak	100	218 HORIZONTAL
4	7303.62	36.38	54.00	-17.62	31.80	4.06	35.92	35.40	Average	100	218 HORIZONTAL

Vertical

	Freq	Level	Limit	Over	Read	CableAntenna	Preamp	Remark	A/Pos	T/Pos	Pol/Phase
	MHz	dBuV/m	dBuV/m	dB	dBuV	dB	dB/m	dB	cm	deg	
1	4875.08	46.15	74.00	-27.85	44.69	3.33	33.16	35.03	Peak	100	69 VERTICAL
2	4877.90	32.10	54.00	-21.90	30.64	3.33	33.16	35.03	Average	100	69 VERTICAL
3	7305.84	62.55	74.00	-11.45	57.97	4.06	35.92	35.40	Peak	100	237 VERTICAL
4	7320.72	36.55	54.00	-17.45	31.93	4.06	35.96	35.40	Average	100	237 VERTICAL

Temperature	25°C	Humidity	54%
Test Engineer	Jim Huang	Configurations	IEEE 802.11n MCS8 40MHz CH 9 / 3TX / Chain 1 + Chain 2 + Chain 3
Test Date	Aug. 10, 2013	Test Mode	Mode 1 (Ant.31 PIFA antenna / 4.4dBi)

Horizontal

	Freq	Level	Limit	Over	Read	CableAntenna	Preamp	Remark	A/Pos	T/Pos	Pol/Phase
	MHz	dBuV/m	dBuV/m	dB	dBuV	dB	dB/m	dB	cm	deg	
1	4916.88	30.83	54.00	-23.17	29.27	3.35	33.23	35.02	Average	100	141 HORIZONTAL
2	4917.44	42.68	74.00	-31.32	41.12	3.35	33.23	35.02	Peak	100	141 HORIZONTAL
3	7354.88	33.57	54.00	-20.43	28.89	4.06	36.02	35.40	Average	100	205 HORIZONTAL
4	7372.40	46.31	74.00	-27.69	41.59	4.06	36.06	35.40	Peak	100	205 HORIZONTAL

Vertical

	Freq	Level	Limit	Over	Read	CableAntenna	Preamp	Remark	A/Pos	T/Pos	Pol/Phase
	MHz	dBuV/m	dBuV/m	dB	dBuV	dB	dB/m	dB	cm	deg	
1	4920.44	30.92	54.00	-23.08	29.35	3.35	33.23	35.01	Average	100	144 VERTICAL
2	4920.68	43.66	74.00	-30.34	42.09	3.35	33.23	35.01	Peak	100	144 VERTICAL
3	7345.56	33.88	54.00	-20.12	29.20	4.06	36.02	35.40	Average	100	260 VERTICAL
4	7352.16	45.96	74.00	-28.04	41.28	4.06	36.02	35.40	Peak	100	260 VERTICAL

Temperature	25°C	Humidity	54%
Test Engineer	Kenneth Huang	Configurations	IEEE 802.11n MCS16 20MHz CH 1 / 3TX / Chain 1 + Chain 2 + Chain 3
Test Date	Aug. 12, 2013	Test Mode	Mode 1 (Ant.31 PIFA antenna / 4.4dBi)

Horizontal

	Freq	Level	Limit	Over	Read	CableAntenna	Preamp	Remark	A/Pos	T/Pos	Pol/Phase
	MHz	dBuV/m	dBuV/m	dB	dBuV	Loss	Factor		cm	deg	
1	4822.91	33.43	54.00	-20.57	32.09	3.31	33.06	35.03 Average	129	285	HORIZONTAL
2	4823.50	48.81	74.00	-25.19	47.47	3.31	33.06	35.03 Peak	129	285	HORIZONTAL

Vertical

	Freq	Level	Limit	Over	Read	CableAntenna	Preamp	Remark	A/Pos	T/Pos	Pol/Phase
	MHz	dBuV/m	dBuV/m	dB	dBuV	Loss	Factor		cm	deg	
1	4822.81	33.06	54.00	-20.94	31.72	3.31	33.06	35.03 Average	112	267	VERTICAL
2	4823.41	48.26	74.00	-25.74	46.92	3.31	33.06	35.03 Peak	112	267	VERTICAL

Temperature	25°C	Humidity	54%
Test Engineer	Kenneth Huang	Configurations	IEEE 802.11n MCS16 20MHz CH 6 / 3TX / Chain 1 + Chain 2 + Chain 3
Test Date	Aug. 12, 2013	Test Mode	Mode 1 (Ant.31 PIFA antenna / 4.4dBi)

Horizontal

	Freq	Level	Limit Line	Over Limit	Read Level	CableAntenna Loss	Antenna Factor	Preamp Factor	Remark	A/Pos	T/Pos	Pol/Phase
	MHz	dBuV/m	dBuV/m	dB	dBuV	dB	dB/m	dB		cm	deg	
1	4873.97	30.21	54.00	-23.79	28.75	3.33	33.16	35.03	Average	139	284	HORIZONTAL
2	4874.58	44.22	74.00	-29.78	42.76	3.33	33.16	35.03	Peak	139	284	HORIZONTAL
3	7302.80	65.76	74.00	-8.24	61.18	4.06	35.92	35.40	Peak	152	107	HORIZONTAL
4	7310.94	34.08	54.00	-19.92	29.46	4.06	35.96	35.40	Average	152	107	HORIZONTAL

Vertical

	Freq	Level	Limit Line	Over Limit	Read Level	CableAntenna Loss	Antenna Factor	Preamp Factor	Remark	A/Pos	T/Pos	Pol/Phase
	MHz	dBuV/m	dBuV/m	dB	dBuV	dB	dB/m	dB		cm	deg	
1	4871.31	51.46	74.00	-22.54	50.00	3.33	33.16	35.03	Peak	100	41	VERTICAL
2	4874.16	31.17	54.00	-22.83	29.71	3.33	33.16	35.03	Average	100	41	VERTICAL
3	7303.28	70.03	74.00	-3.97	65.45	4.06	35.92	35.40	Peak	100	69	VERTICAL
4	7314.56	35.56	54.00	-18.44	30.94	4.06	35.96	35.40	Average	100	69	VERTICAL

Temperature	25°C	Humidity	54%
Test Engineer	Kenneth Huang	Configurations	IEEE 802.11n MCS16 20MHz CH 11 / 3TX / Chain 1 + Chain 2 + Chain 3
Test Date	Aug. 12, 2013	Test Mode	Mode 1 (Ant.31 PIFA antenna / 4.4dBi)

Horizontal

	Freq	Level	Limit	Over	Read	CableAntenna	Preamp	Remark	A/Pos	T/Pos	Pol/Phase	
	MHz	dBuV/m	dBuV/m	dB	dBuV	dB	dB/m	dB	cm	deg		
1	4917.17	29.40	54.00	-24.60	27.84	3.35	33.23	35.02	Average	126	348	HORIZONTAL
2	4922.08	43.15	74.00	-30.85	41.55	3.35	33.26	35.01	Peak	126	348	HORIZONTAL
3	7383.66	63.11	74.00	-10.89	58.36	4.06	36.09	35.40	Peak	158	57	HORIZONTAL
4	7388.92	33.44	54.00	-20.56	28.69	4.06	36.09	35.40	Average	158	57	HORIZONTAL

Vertical

	Freq	Level	Limit	Over	Read	CableAntenna	Preamp	Remark	A/Pos	T/Pos	Pol/Phase	
	MHz	dBuV/m	dBuV/m	dB	dBuV	dB	dB/m	dB	cm	deg		
1	4918.26	43.92	74.00	-30.08	42.36	3.35	33.23	35.02	Peak	129	252	VERTICAL
2	4922.75	30.22	54.00	-23.78	28.62	3.35	33.26	35.01	Average	129	252	VERTICAL
3	7383.82	36.27	54.00	-17.73	31.52	4.06	36.09	35.40	Average	114	74	VERTICAL
4	7384.75	70.92	74.00	-3.08	66.17	4.06	36.09	35.40	Peak	114	74	VERTICAL

Temperature	25°C	Humidity	54%
Test Engineer	Kenneth Huang	Configurations	IEEE 802.11n MCS16 40MHz CH 3 / 3TX / Chain 1 + Chain 2 + Chain 3
Test Date	Aug. 12, 2013	Test Mode	Mode 1 (Ant.31 PIFA antenna / 4.4dBi)

Horizontal

	Freq	Level	Limit Line	Over Limit	Read Level	Cable Loss	Antenna Factor	Preamp Factor	Remark	A/Pos	T/Pos	Pol/Phase
	MHz	dBuV/m	dBuV/m	dB	dBuV	dB	dB/m	dB		cm	deg	
1	4834.58	43.11	74.00	-30.89	41.77	3.31	33.06	35.03	Peak	100	351	HORIZONTAL
2	4845.73	28.91	54.00	-25.09	27.53	3.32	33.09	35.03	Average	100	351	HORIZONTAL

Vertical

	Freq	Level	Limit Line	Over Limit	Read Level	Cable Loss	Antenna Factor	Preamp Factor	Remark	A/Pos	T/Pos	Pol/Phase
	MHz	dBuV/m	dBuV/m	dB	dBuV	dB	dB/m	dB		cm	deg	
1	4842.05	43.26	74.00	-30.74	41.88	3.32	33.09	35.03	Peak	100	69	VERTICAL
2	4845.47	29.29	54.00	-24.71	27.91	3.32	33.09	35.03	Average	100	69	VERTICAL

Temperature	25°C	Humidity	54%
Test Engineer	Kenneth Huang	Configurations	IEEE 802.11n MCS16 40MHz CH 6 / 3TX / Chain 1 + Chain 2 + Chain 3
Test Date	Aug. 12, 2013	Test Mode	Mode 1 (Ant.31 PIFA antenna / 4.4dBi)

Horizontal

	Freq	Level	Limit	Over	Read	CableAntenna	Preamp	Remark	A/Pos	T/Pos	Pol/Phase	
	MHz	dBuV/m	dBuV/m	dB	dBuV	dB	dB/m	dB	cm	deg		
1	4872.78	31.16	54.00	-22.84	29.70	3.33	33.16	35.03	Average	134	166	HORIZONTAL
2	4875.41	48.94	74.00	-25.06	47.48	3.33	33.16	35.03	Peak	134	166	HORIZONTAL
3	7308.56	68.53	74.00	-5.47	63.91	4.06	35.96	35.40	Peak	156	124	HORIZONTAL
4	7312.03	39.94	54.00	-14.06	35.32	4.06	35.96	35.40	Average	156	124	HORIZONTAL

Vertical

	Freq	Level	Limit	Over	Read	CableAntenna	Preamp	Remark	A/Pos	T/Pos	Pol/Phase	
	MHz	dBuV/m	dBuV/m	dB	dBuV	dB	dB/m	dB	cm	deg		
1	4872.46	49.71	74.00	-24.29	48.25	3.33	33.16	35.03	Peak	100	142	VERTICAL
2	4880.19	31.15	54.00	-22.85	29.69	3.33	33.16	35.03	Average	100	142	VERTICAL
3	7317.15	41.14	54.00	-12.86	36.52	4.06	35.96	35.40	Average	100	71	VERTICAL
4	7318.69	70.08	74.00	-3.92	65.46	4.06	35.96	35.40	Peak	100	71	VERTICAL

Temperature	25°C	Humidity	54%
Test Engineer	Kenneth Huang	Configurations	IEEE 802.11n MCS16 40MHz CH 9 / 3TX / Chain 1 + Chain 2 + Chain 3
Test Date	Aug. 12, 2013	Test Mode	Mode 1 (Ant.31 PIFA antenna / 4.4dBi)

Horizontal

	Freq	Level	Limit Line	Over Limit	Read Level	CableAntenna Loss	Antenna Factor	Preamp Factor	Remark	A/Pos	T/Pos	Pol/Phase
	MHz	dBuV/m	dBuV/m	dB	dBuV	dB	dB/m	dB		cm	deg	
1	4905.06	43.29	74.00	-30.71	41.74	3.34	33.23	35.02	Peak	100	39	HORIZONTAL
2	4906.15	29.23	54.00	-24.77	27.68	3.34	33.23	35.02	Average	100	39	HORIZONTAL
3	7347.38	32.51	54.00	-21.49	27.83	4.06	36.02	35.40	Average	100	346	HORIZONTAL
4	7359.69	47.10	74.00	-26.90	42.38	4.06	36.06	35.40	Peak	100	346	HORIZONTAL

Vertical

	Freq	Level	Limit Line	Over Limit	Read Level	CableAntenna Loss	Antenna Factor	Preamp Factor	Remark	A/Pos	T/Pos	Pol/Phase
	MHz	dBuV/m	dBuV/m	dB	dBuV	dB	dB/m	dB		cm	deg	
1	4900.28	44.19	74.00	-29.81	42.68	3.34	33.19	35.02	Peak	100	280	VERTICAL
2	4905.96	29.09	54.00	-24.91	27.54	3.34	33.23	35.02	Average	100	280	VERTICAL
3	7349.97	48.50	74.00	-25.50	43.82	4.06	36.02	35.40	Peak	100	113	VERTICAL
4	7354.69	32.57	54.00	-21.43	27.89	4.06	36.02	35.40	Average	100	113	VERTICAL

Temperature	25°C	Humidity	54%
Test Engineer	Kenneth Huang	Configurations	IEEE 802.11b CH 1 / 1TX / Chain 1
Test Date	Aug. 13, 2013	Test Mode	Mode 1 (Ant.31 PIFA antenna / 4.4dBi)

Horizontal

	Freq	Level	Limit Line	Over Limit	Read Level	CableAntenna Loss	Antenna Factor	Preamp Factor	Remark	A/Pos	T/Pos	Pol/Phase
	MHz	dBuV/m	dBuV/m	dB	dBuV	dB	dB/m	dB		cm	deg	
1	4823.92	47.62	74.00	-26.38	46.28	3.31	33.06	35.03	Peak	100	172	HORIZONTAL
2	4823.96	41.68	54.00	-12.32	40.34	3.31	33.06	35.03	Average	100	172	HORIZONTAL

Vertical

	Freq	Level	Limit Line	Over Limit	Read Level	CableAntenna Loss	Antenna Factor	Preamp Factor	Remark	A/Pos	T/Pos	Pol/Phase
	MHz	dBuV/m	dBuV/m	dB	dBuV	dB	dB/m	dB		cm	deg	
1	4823.93	48.07	74.00	-25.93	46.73	3.31	33.06	35.03	Peak	100	227	VERTICAL
2	4823.97	42.84	54.00	-11.16	41.50	3.31	33.06	35.03	Average	100	227	VERTICAL

Temperature	25°C	Humidity	54%
Test Engineer	Kenneth Huang	Configurations	IEEE 802.11b CH 6 / 1TX / Chain 1
Test Date	Aug. 13, 2013	Test Mode	Mode 1 (Ant.31 PIFA antenna / 4.4dBi)

Horizontal

	Freq	Level	Limit	Over	Read	Cable	Antenna	Preamp	Remark	A/Pos	T/Pos	Pol/Phase
	MHz	dBuV/m	dBuV/m	dB	dBuV	Loss	Factor	Factor		cm	deg	
1	4873.98	47.29	74.00	-26.71	45.83	3.33	33.16	35.03	Peak	103	276	HORIZONTAL
2	4873.99	40.80	54.00	-13.20	39.34	3.33	33.16	35.03	Average	103	276	HORIZONTAL
3	7309.93	55.66	74.00	-18.34	51.04	4.06	35.96	35.40	Peak	136	124	HORIZONTAL
4	7310.24	49.99	54.00	-4.01	45.37	4.06	35.96	35.40	Average	136	124	HORIZONTAL

Vertical

	Freq	Level	Limit	Over	Read	Cable	Antenna	Preamp	Remark	A/Pos	T/Pos	Pol/Phase
	MHz	dBuV/m	dBuV/m	dB	dBuV	Loss	Factor	Factor		cm	deg	
1	4873.96	43.84	54.00	-10.16	42.38	3.33	33.16	35.03	Average	116	341	VERTICAL
2	4873.97	48.56	74.00	-25.44	47.10	3.33	33.16	35.03	Peak	116	341	VERTICAL
3	7310.10	55.54	74.00	-18.46	50.92	4.06	35.96	35.40	Peak	100	41	VERTICAL
4	7310.25	50.38	54.00	-3.62	45.76	4.06	35.96	35.40	Average	100	41	VERTICAL

Temperature	25°C	Humidity	54%
Test Engineer	Kenneth Huang	Configurations	IEEE 802.11b CH 11 / 1TX / Chain 1
Test Date	Aug. 13, 2013	Test Mode	Mode 1 (Ant.31 PIFA antenna / 4.4dBi)

Horizontal

	Freq	Level	Limit	Over	Read	CableAntenna	Preamp	Remark	A/Pos	T/Pos	Pol/Phase	
	MHz	dBuV/m	dBuV/m	dB	dBuV	dB	dB/m	dB	cm	deg		
1	4924.00	40.27	54.00	-13.73	38.67	3.35	33.26	35.01	Average	100	267	HORIZONTAL
2	4924.00	47.48	74.00	-26.52	45.88	3.35	33.26	35.01	Peak	100	267	HORIZONTAL
3	7385.22	41.37	54.00	-12.63	36.62	4.06	36.09	35.40	Average	127	116	HORIZONTAL
4	7387.02	50.62	74.00	-23.38	45.87	4.06	36.09	35.40	Peak	127	116	HORIZONTAL

Vertical

	Freq	Level	Limit	Over	Read	CableAntenna	Preamp	Remark	A/Pos	T/Pos	Pol/Phase	
	MHz	dBuV/m	dBuV/m	dB	dBuV	dB	dB/m	dB	cm	deg		
1	4923.99	40.89	54.00	-13.11	39.29	3.35	33.26	35.01	Average	100	110	VERTICAL
2	4924.00	47.62	74.00	-26.38	46.02	3.35	33.26	35.01	Peak	100	110	VERTICAL
3	7385.23	43.21	54.00	-10.79	38.46	4.06	36.09	35.40	Average	100	44	VERTICAL
4	7386.73	51.42	74.00	-22.58	46.67	4.06	36.09	35.40	Peak	100	44	VERTICAL

Temperature	25°C	Humidity	54%
Test Engineer	Jim Huang	Configurations	IEEE 802.11b CH 1 / 2TX / Chain 1 + Chain 2
Test Date	Aug. 13, 2013	Test Mode	Mode 1 (Ant.31 PIFA antenna / 4.4dBi)

Horizontal

	Freq	Level	Limit	Over	Read	Cable	Antenna	Preamp	Remark	A/Pos	T/Pos	Pol/Phase
	MHz	dBuV/m	dBuV/m	dB	dBuV	Loss	Factor	Factor		cm	deg	
1	4823.97	45.69	54.00	-8.31	44.35	3.31	33.06	35.03	Average	100	172	HORIZONTAL
2	4824.02	49.86	74.00	-24.14	48.52	3.31	33.06	35.03	Peak	100	172	HORIZONTAL

Vertical

	Freq	Level	Limit	Over	Read	Cable	Antenna	Preamp	Remark	A/Pos	T/Pos	Pol/Phase
	MHz	dBuV/m	dBuV/m	dB	dBuV	Loss	Factor	Factor		cm	deg	
1	4823.97	46.78	54.00	-7.22	45.44	3.31	33.06	35.03	Average	100	226	VERTICAL
2	4823.97	50.70	74.00	-23.30	49.36	3.31	33.06	35.03	Peak	100	226	VERTICAL

Temperature	25°C	Humidity	54%
Test Engineer	Jim Huang	Configurations	IEEE 802.11b CH 6 / 2TX / Chain 1 + Chain 2
Test Date	Aug. 13, 2013	Test Mode	Mode 1 (Ant.31 PIFA antenna / 4.4dBi)

Horizontal

	Freq	Level	Limit	Over	Read	CableAntenna	Preamp	Remark	A/Pos	T/Pos	Pol/Phase
	MHz	dBuV/m	dBuV/m	dB	dBuV	dB	dB/m	dB	cm	deg	
1	4873.90	49.57	74.00	-24.43	48.11	3.33	33.16	35.03	105	168	HORIZONTAL
2	4873.97	45.28	54.00	-8.72	43.82	3.33	33.16	35.03	105	168	HORIZONTAL
3	7311.69	50.16	54.00	-3.84	45.54	4.06	35.96	35.40	150	104	HORIZONTAL
4	7311.88	55.34	74.00	-18.66	50.72	4.06	35.96	35.40	150	104	HORIZONTAL

Vertical

	Freq	Level	Limit	Over	Read	CableAntenna	Preamp	Remark	A/Pos	T/Pos	Pol/Phase
	MHz	dBuV/m	dBuV/m	dB	dBuV	dB	dB/m	dB	cm	deg	
1	4873.97	46.93	54.00	-7.07	45.47	3.33	33.16	35.03	170	229	VERTICAL
2	4873.98	50.47	74.00	-23.53	49.01	3.33	33.16	35.03	170	229	VERTICAL
3	7309.51	55.38	74.00	-18.62	50.76	4.06	35.96	35.40	101	60	VERTICAL
4	7310.23	49.65	54.00	-4.35	45.03	4.06	35.96	35.40	101	60	VERTICAL



Temperature	25°C	Humidity	54%
Test Engineer	Jim Huang	Configurations	IEEE 802.11b CH 11 / 2TX / Chain 1 + Chain 2
Test Date	Aug. 13, 2013	Test Mode	Mode 1 (Ant.31 PIFA antenna / 4.4dBi)

Horizontal

	Freq	Level	Limit	Over	Read	CableAntenna	Preamp	Remark	A/Pos	T/Pos	Pol/Phase
	MHz	dBuV/m	dBuV/m	dB	dBuV	dB	dB/m	dB	cm	deg	
1	4923.87	46.61	74.00	-27.39	45.01	3.35	33.26	35.01	128	280	HORIZONTAL
2	4923.95	40.69	54.00	-13.31	39.09	3.35	33.26	35.01	128	280	HORIZONTAL
3	7385.46	48.09	74.00	-25.91	43.34	4.06	36.09	35.40	100	157	HORIZONTAL
4	7386.66	36.33	54.00	-17.67	31.58	4.06	36.09	35.40	100	157	HORIZONTAL

Vertical

	Freq	Level	Limit	Over	Read	CableAntenna	Preamp	Remark	A/Pos	T/Pos	Pol/Phase
	MHz	dBuV/m	dBuV/m	dB	dBuV	dB	dB/m	dB	cm	deg	
1	4923.91	41.94	54.00	-12.06	40.34	3.35	33.26	35.01	205	225	VERTICAL
2	4924.00	47.66	74.00	-26.34	46.06	3.35	33.26	35.01	205	225	VERTICAL
3	7386.75	38.84	54.00	-15.16	34.09	4.06	36.09	35.40	100	43	VERTICAL
4	7387.00	49.13	74.00	-24.87	44.38	4.06	36.09	35.40	100	43	VERTICAL

Temperature	25°C	Humidity	54%
Test Engineer	Jim Huang	Configurations	IEEE 802.11b CH 1 / 3TX / Chain 1 + Chain 2 + Chain 3
Test Date	Aug. 09, 2013	Test Mode	Mode 1 (Ant.31 PIFA antenna / 4.4dBi)

Horizontal

	Freq	Level	Limit	Over	Read	Cable	Antenna	Preamp	Remark	A/Pos	T/Pos	Pol/Phase
	MHz	dBuV/m	dBuV/m	dB	dBuV	Loss	Factor	Factor		cm	deg	
1	4823.93	48.45	54.00	-5.55	47.11	3.31	33.06	35.03	Average	160	44	HORIZONTAL
2	4823.97	51.99	74.00	-22.01	50.65	3.31	33.06	35.03	Peak	160	44	HORIZONTAL

Vertical

	Freq	Level	Limit	Over	Read	Cable	Antenna	Preamp	Remark	A/Pos	T/Pos	Pol/Phase
	MHz	dBuV/m	dBuV/m	dB	dBuV	Loss	Factor	Factor		cm	deg	
1	4823.90	53.67	74.00	-20.33	52.33	3.31	33.06	35.03	Peak	100	69	VERTICAL
2	4823.93	50.66	54.00	-3.34	49.32	3.31	33.06	35.03	Average	100	69	VERTICAL

Temperature	25°C	Humidity	54%
Test Engineer	Jim Huang	Configurations	IEEE 802.11b CH 6 / 3TX / Chain 1 + Chain 2 + Chain 3
Test Date	Aug. 09, 2013	Test Mode	Mode 1 (Ant.31 PIFA antenna / 4.4dBi)

Horizontal

	Freq	Level	Limit	Over	Read	CableAntenna	Preamp	Remark	A/Pos	T/Pos	Pol/Phase
	MHz	dBuV/m	dBuV/m	dB	dBuV	dB	dB/m	dB	cm	deg	
1	4873.98	49.79	54.00	-4.21	48.33	3.33	33.16	35.03	166	51	HORIZONTAL
2	4874.02	53.14	74.00	-20.86	51.68	3.33	33.16	35.03	166	51	HORIZONTAL
3	7310.21	41.93	54.00	-12.07	37.31	4.06	35.96	35.40	166	305	HORIZONTAL
4	7310.28	50.85	74.00	-23.15	46.23	4.06	35.96	35.40	166	305	HORIZONTAL

Vertical

	Freq	Level	Limit	Over	Read	CableAntenna	Preamp	Remark	A/Pos	T/Pos	Pol/Phase
	MHz	dBuV/m	dBuV/m	dB	dBuV	dB	dB/m	dB	cm	deg	
1	4873.93	50.90	54.00	-3.10	49.44	3.33	33.16	35.03	114	74	VERTICAL
2	4873.95	53.94	74.00	-20.06	52.48	3.33	33.16	35.03	114	74	VERTICAL
3	7311.69	41.89	54.00	-12.11	37.27	4.06	35.96	35.40	102	239	VERTICAL
4	7311.87	50.86	74.00	-23.14	46.24	4.06	35.96	35.40	102	239	VERTICAL

Temperature	25°C	Humidity	54%
Test Engineer	Jim Huang	Configurations	IEEE 802.11b CH 11 / 3TX / Chain 1 + Chain 2 + Chain 3
Test Date	Aug. 09, 2013	Test Mode	Mode 1 (Ant.31 PIFA antenna / 4.4dBi)

Horizontal

	Freq	Level	Limit	Over	Read	CableAntenna	Preamp	Remark	A/Pos	T/Pos	Pol/Phase
	MHz	dBuV/m	dBuV/m	dB	dBuV	dB	dB/m	dB	cm	deg	
1	4923.86	51.33	74.00	-22.67	49.73	3.35	33.26	35.01	Peak	162	49 HORIZONTAL
2	4923.97	47.84	54.00	-6.16	46.24	3.35	33.26	35.01	Average	162	49 HORIZONTAL
3	7385.01	48.58	74.00	-25.42	43.83	4.06	36.09	35.40	Peak	100	226 HORIZONTAL
4	7386.76	37.83	54.00	-16.17	33.08	4.06	36.09	35.40	Average	100	226 HORIZONTAL

Vertical

	Freq	Level	Limit	Over	Read	CableAntenna	Preamp	Remark	A/Pos	T/Pos	Pol/Phase
	MHz	dBuV/m	dBuV/m	dB	dBuV	dB	dB/m	dB	cm	deg	
1	4923.97	50.66	54.00	-3.34	49.06	3.35	33.26	35.01	Average	126	76 VERTICAL
2	4923.98	53.35	74.00	-20.65	51.75	3.35	33.26	35.01	Peak	126	76 VERTICAL
3	7386.73	41.48	54.00	-12.52	36.73	4.06	36.09	35.40	Average	101	253 VERTICAL
4	7387.06	50.69	74.00	-23.31	45.94	4.06	36.09	35.40	Peak	101	253 VERTICAL

Temperature	25°C	Humidity	54%
Test Engineer	Kenneth Huang	Configurations	IEEE 802.11g CH 1 / 1TX / Chain 1
Test Date	Aug. 13, 2013	Test Mode	Mode 1 (Ant.31 PIFA antenna / 4.4dBi)

Horizontal

	Freq	Level	Limit Line	Over Limit	Read Level	CableAntenna Loss	Antenna Factor	Preamp Factor	Remark	A/Pos	T/Pos	Pol/Phase
	MHz	dBuV/m	dBuV/m	dB	dBuV	dB	dB/m	dB		cm	deg	
1	4816.72	30.22	54.00	-23.78	28.93	3.31	33.02	35.04	Average	100	267	HORIZONTAL
2	4818.23	43.92	74.00	-30.08	42.62	3.31	33.02	35.03	Peak	100	267	HORIZONTAL

Vertical

	Freq	Level	Limit Line	Over Limit	Read Level	CableAntenna Loss	Antenna Factor	Preamp Factor	Remark	A/Pos	T/Pos	Pol/Phase
	MHz	dBuV/m	dBuV/m	dB	dBuV	dB	dB/m	dB		cm	deg	
1	4815.99	43.30	74.00	-30.70	42.01	3.31	33.02	35.04	Peak	119	41	VERTICAL
2	4821.98	30.53	54.00	-23.47	29.19	3.31	33.06	35.03	Average	119	41	VERTICAL

Temperature	25°C	Humidity	54%
Test Engineer	Kenneth Huang	Configurations	IEEE 802.11g CH 6 / 1TX / Chain 1
Test Date	Aug. 13, 2013	Test Mode	Mode 1 (Ant.31 PIFA antenna / 4.4dBi)

Horizontal

	Freq	Level	Limit	Over	Read	Cable	Antenna	Preamp	Remark	A/Pos	T/Pos	Pol/Phase
	MHz	dBuV/m	dBuV/m	dB	dBuV	Loss	Factor	Factor		cm	deg	
1	4871.18	30.62	54.00	-23.38	29.16	3.33	33.16	35.03	Average	100	154	HORIZONTAL
2	4873.14	42.99	74.00	-31.01	41.53	3.33	33.16	35.03	Peak	100	154	HORIZONTAL
3	7306.16	64.66	74.00	-9.34	60.08	4.06	35.92	35.40	Peak	137	124	HORIZONTAL
4	7309.59	48.04	54.00	-5.96	43.42	4.06	35.96	35.40	Average	137	124	HORIZONTAL

Vertical

	Freq	Level	Limit	Over	Read	Cable	Antenna	Preamp	Remark	A/Pos	T/Pos	Pol/Phase
	MHz	dBuV/m	dBuV/m	dB	dBuV	Loss	Factor	Factor		cm	deg	
1	4874.45	31.84	54.00	-22.16	30.38	3.33	33.16	35.03	Average	115	341	VERTICAL
2	4874.48	46.24	74.00	-27.76	44.78	3.33	33.16	35.03	Peak	115	341	VERTICAL
3	7304.24	65.59	74.00	-8.41	61.01	4.06	35.92	35.40	Peak	101	42	VERTICAL
4	7308.63	48.86	54.00	-5.14	44.24	4.06	35.96	35.40	Average	101	42	VERTICAL

Temperature	25°C	Humidity	54%
Test Engineer	Kenneth Huang	Configurations	IEEE 802.11g CH 11 / 1TX / Chain 1
Test Date	Aug. 13, 2013	Test Mode	Mode 1 (Ant.31 PIFA antenna / 4.4dBi)

Horizontal

	Freq	Level	Limit	Over	Read	CableAntenna	Preamp	Remark	A/Pos	T/Pos	Pol/Phase	
	MHz	dBuV/m	dBuV/m	dB	dBuV	dB	dB/m	dB	cm	deg		
1	4919.10	43.51	74.00	-30.49	41.95	3.35	33.23	35.02	Peak	100	12	HORIZONTAL
2	4926.12	30.58	54.00	-23.42	28.98	3.35	33.26	35.01	Average	100	12	HORIZONTAL
3	7388.24	35.43	54.00	-18.57	30.68	4.06	36.09	35.40	Average	131	107	HORIZONTAL
4	7389.94	51.52	74.00	-22.48	46.77	4.06	36.09	35.40	Peak	131	107	HORIZONTAL

Vertical

	Freq	Level	Limit	Over	Read	CableAntenna	Preamp	Remark	A/Pos	T/Pos	Pol/Phase	
	MHz	dBuV/m	dBuV/m	dB	dBuV	dB	dB/m	dB	cm	deg		
1	4921.98	43.48	74.00	-30.52	41.88	3.35	33.26	35.01	Peak	100	312	VERTICAL
2	4922.21	30.72	54.00	-23.28	29.12	3.35	33.26	35.01	Average	100	312	VERTICAL
3	7388.37	36.06	54.00	-17.94	31.31	4.06	36.09	35.40	Average	100	45	VERTICAL
4	7393.05	54.79	74.00	-19.21	50.00	4.06	36.13	35.40	Peak	100	45	VERTICAL

Temperature	25°C	Humidity	54%
Test Engineer	Jim Huang	Configurations	IEEE 802.11g CH 1 / 2TX / Chain 1 + Chain 2
Test Date	Aug. 13, 2013	Test Mode	Mode 1 (Ant.31 PIFA antenna / 4.4dBi)

Horizontal

	Freq	Level	Limit	Over	Read	CableAntenna	Preamp	Remark	A/Pos	T/Pos	Pol/Phase
	MHz	dBuV/m	dBuV/m	dB	dBuV	dB	dB/m	dB	cm	deg	
1	4822.97	31.14	54.00	-22.86	29.80	3.31	33.06	35.03	Average	100	170 HORIZONTAL
2	4832.46	43.61	74.00	-30.39	42.27	3.31	33.06	35.03	Peak	100	170 HORIZONTAL

Vertical

	Freq	Level	Limit	Over	Read	CableAntenna	Preamp	Remark	A/Pos	T/Pos	Pol/Phase
	MHz	dBuV/m	dBuV/m	dB	dBuV	dB	dB/m	dB	cm	deg	
1	4822.37	42.81	74.00	-31.19	41.47	3.31	33.06	35.03	Peak	100	302 VERTICAL
2	4823.49	31.31	54.00	-22.69	29.97	3.31	33.06	35.03	Average	100	302 VERTICAL

Temperature	25°C	Humidity	54%
Test Engineer	Jim Huang	Configurations	IEEE 802.11g CH 6 / 2TX / Chain 1 + Chain 2
Test Date	Aug. 13, 2013	Test Mode	Mode 1 (Ant.31 PIFA antenna / 4.4dBi)

Horizontal

	Freq	Level	Limit	Over	Read	CableAntenna	Preamp	Remark	A/Pos	T/Pos	Pol/Phase
	MHz	dBuV/m	dBuV/m	dB	dBuV	dB	dB/m	dB	cm	deg	
1	4872.89	32.59	54.00	-21.41	31.13	3.33	33.16	35.03	Average	100	171 HORIZONTAL
2	4878.66	44.44	74.00	-29.56	42.98	3.33	33.16	35.03	Peak	100	171 HORIZONTAL
3	7314.85	44.93	54.00	-9.07	40.31	4.06	35.96	35.40	Average	100	147 HORIZONTAL
4	7319.89	60.74	74.00	-13.26	56.12	4.06	35.96	35.40	Peak	100	147 HORIZONTAL

Vertical

	Freq	Level	Limit	Over	Read	CableAntenna	Preamp	Remark	A/Pos	T/Pos	Pol/Phase
	MHz	dBuV/m	dBuV/m	dB	dBuV	dB	dB/m	dB	cm	deg	
1	4876.64	32.96	54.00	-21.04	31.50	3.33	33.16	35.03	Average	100	147 VERTICAL
2	4882.17	46.63	74.00	-27.37	45.17	3.33	33.16	35.03	Peak	100	147 VERTICAL
3	7303.93	63.88	74.00	-10.12	59.30	4.06	35.92	35.40	Peak	100	59 VERTICAL
4	7314.46	46.60	54.00	-7.40	41.98	4.06	35.96	35.40	Average	100	59 VERTICAL

Temperature	25°C	Humidity	54%
Test Engineer	Jim Huang	Configurations	IEEE 802.11g CH 11 / 2TX / Chain 1 + Chain 2
Test Date	Aug. 13, 2013	Test Mode	Mode 1 (Ant.31 PIFA antenna / 4.4dBi)

Horizontal

	Freq	Level	Limit	Over	Read	CableAntenna	Preamp	Remark	A/Pos	T/Pos	Pol/Phase
	MHz	dBuV/m	dBuV/m	dB	dBuV	dB	dB/m	dB	cm	deg	
1	4923.14	31.27	54.00	-22.73	29.67	3.35	33.26	35.01	Average	100	145 HORIZONTAL
2	4939.00	42.69	74.00	-31.31	41.05	3.35	33.30	35.01	Peak	100	145 HORIZONTAL
3	7385.04	34.98	54.00	-19.02	30.23	4.06	36.09	35.40	Average	100	107 HORIZONTAL
4	7385.52	50.46	74.00	-23.54	45.71	4.06	36.09	35.40	Peak	100	107 HORIZONTAL

Vertical

	Freq	Level	Limit	Over	Read	CableAntenna	Preamp	Remark	A/Pos	T/Pos	Pol/Phase
	MHz	dBuV/m	dBuV/m	dB	dBuV	dB	dB/m	dB	cm	deg	
1	4912.70	42.91	74.00	-31.09	41.36	3.34	33.23	35.02	Peak	100	346 VERTICAL
2	4922.99	31.51	54.00	-22.49	29.91	3.35	33.26	35.01	Average	100	346 VERTICAL
3	7377.73	33.46	54.00	-20.54	28.71	4.06	36.09	35.40	Average	100	222 VERTICAL
4	7391.91	46.14	74.00	-27.86	41.39	4.06	36.09	35.40	Peak	100	222 VERTICAL

Temperature	25°C	Humidity	54%
Test Engineer	Jim Huang	Configurations	IEEE 802.11g CH 1 / 3TX / Chain 1 + Chain 2 + Chain 3
Test Date	Aug. 09, 2013	Test Mode	Mode 1 (Ant.31 PIFA antenna / 4.4dBi)

Horizontal

	Freq	Level	Limit	Over	Read	Cable	Antenna	Preamp	Remark	A/Pos	T/Pos	Pol/Phase
	MHz	dBuV/m	dBuV/m	dB	dBuV	Loss	Factor	Factor		cm	deg	
1	4823.82	35.89	54.00	-18.11	34.55	3.31	33.06	35.03	Average	155	47	HORIZONTAL
2	4824.24	49.91	74.00	-24.09	48.57	3.31	33.06	35.03	Peak	155	47	HORIZONTAL

Vertical

	Freq	Level	Limit	Over	Read	Cable	Antenna	Preamp	Remark	A/Pos	T/Pos	Pol/Phase
	MHz	dBuV/m	dBuV/m	dB	dBuV	Loss	Factor	Factor		cm	deg	
1	4823.88	37.95	54.00	-16.05	36.61	3.31	33.06	35.03	Average	100	70	VERTICAL
2	4824.90	52.45	74.00	-21.55	51.11	3.31	33.06	35.03	Peak	100	70	VERTICAL

Temperature	25°C	Humidity	54%
Test Engineer	Jim Huang	Configurations	IEEE 802.11g CH 6 / 3TX / Chain 1 + Chain 2 + Chain 3
Test Date	Aug. 09, 2013	Test Mode	Mode 1 (Ant.31 PIFA antenna / 4.4dBi)

Horizontal

	Freq	Level	Limit	Over	Read	CableAntenna	Preamp	Remark	A/Pos	T/Pos	Pol/Phase
	MHz	dBuV/m	dBuV/m	dB	dBuV	dB	dB/m	dB	cm	deg	
1	4874.18	34.71	54.00	-19.29	33.25	3.33	33.16	35.03	Average	100	31 HORIZONTAL
2	4878.20	47.95	74.00	-26.05	46.49	3.33	33.16	35.03	Peak	100	31 HORIZONTAL
3	7314.48	38.84	54.00	-15.16	34.22	4.06	35.96	35.40	Average	168	312 HORIZONTAL
4	7315.08	69.67	74.00	-4.33	65.05	4.06	35.96	35.40	Peak	168	312 HORIZONTAL

Vertical

	Freq	Level	Limit	Over	Read	CableAntenna	Preamp	Remark	A/Pos	T/Pos	Pol/Phase
	MHz	dBuV/m	dBuV/m	dB	dBuV	dB	dB/m	dB	cm	deg	
1	4873.16	34.93	54.00	-19.07	33.47	3.33	33.16	35.03	Average	100	73 VERTICAL
2	4873.16	54.21	74.00	-19.79	52.75	3.33	33.16	35.03	Peak	100	73 VERTICAL
3	7312.00	70.36	74.00	-3.64	65.74	4.06	35.96	35.40	Peak	135	242 VERTICAL
4	7316.80	38.51	54.00	-15.49	33.89	4.06	35.96	35.40	Average	135	242 VERTICAL

Temperature	25°C	Humidity	54%
Test Engineer	Jim Huang	Configurations	IEEE 802.11g CH 11 / 3TX / Chain 1 + Chain 2 + Chain 3
Test Date	Aug. 09, 2013	Test Mode	Mode 1 (Ant.31 PIFA antenna / 4.4dBi)

Horizontal

	Freq	Level	Limit	Over	Read	CableAntenna	Preamp	Remark	A/Pos	T/Pos	Pol/Phase
	MHz	dBuV/m	dBuV/m	dB	dBuV	dB	dB/m	dB	cm	deg	
1	4919.50	30.75	54.00	-23.25	29.19	3.35	33.23	35.02	Average	100	95 HORIZONTAL
2	4925.26	44.02	74.00	-29.98	42.42	3.35	33.26	35.01	Peak	100	95 HORIZONTAL
3	7375.98	70.61	74.00	-3.39	65.86	4.06	36.09	35.40	Peak	166	301 HORIZONTAL
4	7384.92	38.59	54.00	-15.41	33.84	4.06	36.09	35.40	Average	166	301 HORIZONTAL

Vertical

	Freq	Level	Limit	Over	Read	CableAntenna	Preamp	Remark	A/Pos	T/Pos	Pol/Phase
	MHz	dBuV/m	dBuV/m	dB	dBuV	dB	dB/m	dB	cm	deg	
1	4923.04	34.29	54.00	-19.71	32.69	3.35	33.26	35.01	Average	100	71 VERTICAL
2	4924.12	46.53	74.00	-27.47	44.93	3.35	33.26	35.01	Peak	100	71 VERTICAL
3	7374.48	70.61	74.00	-3.39	65.89	4.06	36.06	35.40	Peak	100	240 VERTICAL
4	7389.00	38.13	54.00	-15.87	33.38	4.06	36.09	35.40	Average	100	240 VERTICAL

Temperature	25°C	Humidity	54%
Test Engineer	Serway Li	Configurations	IEEE 802.11n MCS0 20MHz CH 149 / 1TX / Chain 1
Test Date	Aug. 31, 2013	Test Mode	Mode 2 (Ant.31 PIFA antenna / 4.7dBi)

Horizontal

	Freq	Level	Limit	Over	Read	Cable	Antenna	Preamp	Remark	A/Pos	T/Pos	Pol/Phase
	MHz	dBuV/m	dBuV/m	dB	dBuV	Loss	Factor	Factor		cm	deg	
1	11491.92	40.94	54.00	-13.06	32.33	5.11	38.78	35.28	Average	101	156	HORIZONTAL
2	11492.32	51.85	74.00	-22.15	43.24	5.11	38.78	35.28	Peak	101	156	HORIZONTAL

Vertical

	Freq	Level	Limit	Over	Read	Cable	Antenna	Preamp	Remark	A/Pos	T/Pos	Pol/Phase
	MHz	dBuV/m	dBuV/m	dB	dBuV	Loss	Factor	Factor		cm	deg	
1	11488.96	43.72	54.00	-10.28	35.11	5.11	38.78	35.28	Average	192	35	VERTICAL
2	11490.08	56.94	74.00	-17.06	48.33	5.11	38.78	35.28	Peak	192	35	VERTICAL

Temperature	25°C	Humidity	54%
Test Engineer	Serway Li	Configurations	IEEE 802.11n MCS0 20MHz CH 157 / 1TX / Chain 1
Test Date	Aug. 31, 2013	Test Mode	Mode 2 (Ant.31 PIFA antenna / 4.7dBi)

Horizontal

	Freq	Level	Limit	Over	Read	CableAntenna	Preamp	Remark	A/Pos	T/Pos	Pol/Phase
	MHz	dBuV/m	dBuV/m	dB	dBuV	dB	dB/m	dB	cm	deg	
1	11569.04	42.26	54.00	-11.74	33.60	5.13	38.83	35.30 Average	102	336	HORIZONTAL
2	11570.24	56.62	74.00	-17.38	47.95	5.14	38.83	35.30 Peak	102	336	HORIZONTAL

Vertical

	Freq	Level	Limit	Over	Read	CableAntenna	Preamp	Remark	A/Pos	T/Pos	Pol/Phase
	MHz	dBuV/m	dBuV/m	dB	dBuV	dB	dB/m	dB	cm	deg	
1	11567.20	43.02	54.00	-10.98	34.37	5.13	38.82	35.30 Average	100	315	VERTICAL
2	11568.24	54.05	74.00	-19.95	45.39	5.13	38.83	35.30 Peak	100	315	VERTICAL

Temperature	25°C	Humidity	54%
Test Engineer	Serway Li	Configurations	IEEE 802.11n MCS0 20MHz CH 165 / 1TX / Chain 1
Test Date	Aug. 31, 2013	Test Mode	Mode 2 (Ant.31 PIFA antenna / 4.7dBi)

Horizontal

	Freq	Level	Limit Line	Over Limit	Read Level	CableAntenna Loss	Antenna Factor	Preamp Factor	Remark	A/Pos	T/Pos	Pol/Phase
	MHz	dBuV/m	dBuV/m	dB	dBuV	dB	dB/m	dB		cm	deg	
1	11645.51	55.49	74.00	-18.51	46.77	5.16	38.86	35.30	Peak	118	291	HORIZONTAL
2	11649.44	41.58	54.00	-12.42	32.86	5.16	38.86	35.30	Average	118	291	HORIZONTAL

Vertical

	Freq	Level	Limit Line	Over Limit	Read Level	CableAntenna Loss	Antenna Factor	Preamp Factor	Remark	A/Pos	T/Pos	Pol/Phase
	MHz	dBuV/m	dBuV/m	dB	dBuV	dB	dB/m	dB		cm	deg	
1	11647.92	55.63	74.00	-18.37	46.91	5.16	38.86	35.30	Peak	124	246	VERTICAL
2	11648.72	43.25	54.00	-10.75	34.53	5.16	38.86	35.30	Average	124	246	VERTICAL

Temperature	25°C	Humidity	54%
Test Engineer	Serway Li	Configurations	IEEE 802.11n MCS0 40MHz CH 151 / 1TX / Chain 1
Test Date	Aug. 31, 2013	Test Mode	Mode 2 (Ant.31 PIFA antenna / 4.7dBi)

Horizontal

	Freq	Level	Limit Line	Over Limit	Read Level	CableAntenna Loss	Antenna Factor	Preamp Factor	Remark	A/Pos	T/Pos	Pol/Phase
	MHz	dBuV/m	dBuV/m	dB	dBuV	dB	dB/m	dB		cm	deg	
1	11510.28	54.95	74.00	-19.05	46.32	5.12	38.79	35.28	Peak	117	305	HORIZONTAL
2	11510.50	40.71	54.00	-13.29	32.08	5.12	38.79	35.28	Average	117	305	HORIZONTAL

Vertical

	Freq	Level	Limit Line	Over Limit	Read Level	CableAntenna Loss	Antenna Factor	Preamp Factor	Remark	A/Pos	T/Pos	Pol/Phase
	MHz	dBuV/m	dBuV/m	dB	dBuV	dB	dB/m	dB		cm	deg	
1	11509.04	41.38	54.00	-12.62	32.75	5.12	38.79	35.28	Average	164	32	VERTICAL
2	11511.12	54.65	74.00	-19.35	46.02	5.12	38.79	35.28	Peak	164	32	VERTICAL

Temperature	25°C	Humidity	54%
Test Engineer	Serway Li	Configurations	IEEE 802.11n MCS0 40MHz CH 159 / 1TX / Chain 1
Test Date	Aug. 31, 2013	Test Mode	Mode 2 (Ant.31 PIFA antenna / 4.7dBi)

Horizontal

	Freq	Level	Limit	Over	Read	Cable	Antenna	Preamp	Remark	A/Pos	T/Pos	Pol/Phase
	MHz	dBuV/m	dBuV/m	dB	dBuV	dB	dB/m	dB		cm	deg	
1	11586.47	52.04	74.00	-21.96	43.37	5.14	38.83	35.30	Peak	130	303	HORIZONTAL
2	11590.24	40.06	54.00	-13.94	31.39	5.14	38.83	35.30	Average	130	303	HORIZONTAL

Vertical

	Freq	Level	Limit	Over	Read	Cable	Antenna	Preamp	Remark	A/Pos	T/Pos	Pol/Phase
	MHz	dBuV/m	dBuV/m	dB	dBuV	dB	dB/m	dB		cm	deg	
1	11568.21	40.90	54.00	-13.10	32.24	5.13	38.83	35.30	Average	100	337	VERTICAL
2	11586.55	53.85	74.00	-20.15	45.18	5.14	38.83	35.30	Peak	100	337	VERTICAL

Temperature	25°C	Humidity	54%
Test Engineer	Serway Li	Configurations	IEEE 802.11n MCS8 20MHz CH 149 / 2TX / Chain 1 + Chain 2
Test Date	Sep. 02, 2013	Test Mode	Mode 2 (Ant.31 PIFA antenna / 4.7dBi)

Horizontal

	Freq	Level	Limit Line	Over Limit	Read Level	CableAntenna Loss	Antenna Factor	Preamp Factor	Remark	A/Pos	T/Pos	Pol/Phase
	MHz	dBuV/m	dBuV/m	dB	dBuV	dB	dB/m	dB		cm	deg	
1	4999.84	52.74	74.00	-21.26	50.97	3.39	33.39	35.01	Peak	130	353	HORIZONTAL
2	4999.99	44.54	54.00	-9.46	42.77	3.39	33.39	35.01	Average	130	353	HORIZONTAL
3	5439.99	46.18	54.00	-7.82	43.58	3.52	34.17	35.09	Average	101	157	HORIZONTAL
4	5440.36	56.15	74.00	-17.85	53.55	3.52	34.17	35.09	Peak	101	157	HORIZONTAL
5	11489.87	53.67	74.00	-20.33	45.06	5.11	38.78	35.28	Peak	110	106	HORIZONTAL
6	11490.08	35.72	54.00	-18.28	27.11	5.11	38.78	35.28	Average	110	106	HORIZONTAL

Vertical

	Freq	Level	Limit Line	Over Limit	Read Level	CableAntenna Loss	Antenna Factor	Preamp Factor	Remark	A/Pos	T/Pos	Pol/Phase
	MHz	dBuV/m	dBuV/m	dB	dBuV	dB	dB/m	dB		cm	deg	
1	4999.92	57.83	74.00	-16.17	56.05	3.39	33.40	35.01	Peak	111	103	VERTICAL
2	4999.98	48.41	54.00	-5.59	46.63	3.39	33.40	35.01	Average	111	103	VERTICAL
3	5439.97	50.14	54.00	-3.86	47.53	3.52	34.18	35.09	Average	100	105	VERTICAL
4	5440.05	59.51	74.00	-14.49	56.90	3.52	34.18	35.09	Peak	100	105	VERTICAL
5	11490.20	37.79	54.00	-16.21	29.18	5.11	38.78	35.28	Average	100	191	VERTICAL
6	11491.10	52.50	74.00	-21.50	43.89	5.11	38.78	35.28	Peak	100	191	VERTICAL

Temperature	25°C	Humidity	54%
Test Engineer	Serway Li	Configurations	IEEE 802.11n MCS8 20MHz CH 157 / 2TX / Chain 1 + Chain 2
Test Date	Sep. 02, 2013	Test Mode	Mode 2 (Ant.31 PIFA antenna / 4.7dBi)

Horizontal

	Freq	Level	Limit Line	Over Limit	Read Level	CableAntenna Loss	Antenna Factor	Preamp Factor	Remark	A/Pos	T/Pos	Pol/Phase
	MHz	dBuV/m	dBuV/m	dB	dBuV	dB	dB/m	dB		cm	deg	
1	5399.95	57.88	74.00	-16.12	55.33	3.51	34.12	35.08	Peak	124	148	HORIZONTAL
2	5399.96	47.89	54.00	-6.11	45.34	3.51	34.12	35.08	Average	124	148	HORIZONTAL
3	11569.99	36.59	54.00	-17.41	27.92	5.14	38.83	35.30	Average	100	257	HORIZONTAL
4	11570.49	48.06	74.00	-25.94	39.39	5.14	38.83	35.30	Peak	100	257	HORIZONTAL

Vertical

	Freq	Level	Limit Line	Over Limit	Read Level	CableAntenna Loss	Antenna Factor	Preamp Factor	Remark	A/Pos	T/Pos	Pol/Phase
	MHz	dBuV/m	dBuV/m	dB	dBuV	dB	dB/m	dB		cm	deg	
1	5399.98	50.85	54.00	-3.15	48.30	3.51	34.12	35.08	Average	100	88	VERTICAL
2	5400.04	60.34	74.00	-13.66	57.79	3.51	34.12	35.08	Peak	100	88	VERTICAL
3	11569.80	51.07	74.00	-22.93	42.40	5.14	38.83	35.30	Peak	101	188	VERTICAL
4	11570.01	38.32	54.00	-15.68	29.65	5.14	38.83	35.30	Average	101	188	VERTICAL

Temperature	25°C	Humidity	54%
Test Engineer	Serway Li	Configurations	IEEE 802.11n MCS8 20MHz CH 165 / 2TX / Chain 1 + Chain 2
Test Date	Sep. 02, 2013	Test Mode	Mode 2 (Ant.31 PIFA antenna / 4.7dBi)

Horizontal

	Freq	Level	Limit	Over	Read	CableAntenna	Preamp	Remark	A/Pos	T/Pos	Pol/Phase	
	MHz	dBuV/m	dBuV/m	dB	dBuV	dB	dB/m	dB	cm	deg		
1	5399.97	48.47	54.00	-5.53	45.92	3.51	34.12	35.08	Average	123	150	HORIZONTAL
2	5400.07	58.81	74.00	-15.19	56.26	3.51	34.12	35.08	Peak	123	150	HORIZONTAL
3	11649.64	50.25	74.00	-23.75	41.53	5.16	38.86	35.30	Peak	100	238	HORIZONTAL
4	11650.48	36.99	54.00	-17.01	28.27	5.16	38.86	35.30	Average	100	238	HORIZONTAL

Vertical

	Freq	Level	Limit	Over	Read	CableAntenna	Preamp	Remark	A/Pos	T/Pos	Pol/Phase	
	MHz	dBuV/m	dBuV/m	dB	dBuV	dB	dB/m	dB	cm	deg		
1	5399.98	59.86	74.00	-14.14	57.31	3.51	34.12	35.08	Peak	100	88	VERTICAL
2	5399.98	50.92	54.00	-3.08	48.37	3.51	34.12	35.08	Average	100	88	VERTICAL
3	11649.76	49.35	74.00	-24.65	40.63	5.16	38.86	35.30	Peak	100	133	VERTICAL
4	11650.05	37.39	54.00	-16.61	28.67	5.16	38.86	35.30	Average	100	133	VERTICAL



Temperature	25°C	Humidity	54%
Test Engineer	Serway Li	Configurations	IEEE 802.11n MCS8 40MHz CH 151 / 2TX / Chain 1 + Chain 2
Test Date	Sep. 02, 2013	Test Mode	Mode 2 (Ant.31 PIFA antenna / 4.7dBi)

Horizontal

	Freq	Level	Limit Line	Over Limit	Read Level	CableAntenna Loss	Antenna Factor	Preamp Factor	Remark	A/Pos	T/Pos	Pol/Phase
	MHz	dBuV/m	dBuV/m	dB	dBuV	dB	dB/m	dB		cm	deg	
1	5399.89	57.87	74.00	-16.13	55.32	3.51	34.12	35.08	Peak	109	152	HORIZONTAL
2	5399.97	46.68	54.00	-7.32	44.13	3.51	34.12	35.08	Average	109	152	HORIZONTAL
3	11510.06	36.36	54.00	-17.64	27.73	5.12	38.79	35.28	Average	100	223	HORIZONTAL
4	11510.42	48.36	74.00	-25.64	39.73	5.12	38.79	35.28	Peak	100	223	HORIZONTAL

Vertical

	Freq	Level	Limit Line	Over Limit	Read Level	CableAntenna Loss	Antenna Factor	Preamp Factor	Remark	A/Pos	T/Pos	Pol/Phase
	MHz	dBuV/m	dBuV/m	dB	dBuV	dB	dB/m	dB		cm	deg	
1	5399.90	59.51	74.00	-14.49	56.96	3.51	34.12	35.08	Peak	114	104	VERTICAL
2	5399.97	50.55	54.00	-3.45	48.00	3.51	34.12	35.08	Average	114	104	VERTICAL
3	11509.98	51.78	74.00	-22.22	43.15	5.12	38.79	35.28	Peak	100	152	VERTICAL
4	11510.20	37.79	54.00	-16.21	29.16	5.12	38.79	35.28	Average	100	152	VERTICAL

Temperature	25°C	Humidity	54%
Test Engineer	Serway Li	Configurations	IEEE 802.11n MCS8 40MHz CH 159 / 2TX / Chain 1 + Chain 2
Test Date	Sep. 02, 2013	Test Mode	Mode 2 (Ant.31 PIFA antenna / 4.7dBi)

Horizontal

	Freq	Level	Limit Line	Over Limit	Read Level	CableAntenna Loss	Antenna Factor	Preamp Factor	Remark	A/Pos	T/Pos	Pol/Phase
	MHz	dBuV/m	dBuV/m	dB	dBuV	dB	dB/m	dB		cm	deg	
1	5399.90	57.30	74.00	-16.70	54.75	3.51	34.12	35.08	Peak	123	151	HORIZONTAL
2	5399.97	47.06	54.00	-6.94	44.51	3.51	34.12	35.08	Average	123	151	HORIZONTAL
3	11589.68	48.19	74.00	-25.81	39.52	5.14	38.83	35.30	Peak	100	155	HORIZONTAL
4	11589.77	35.69	54.00	-18.31	27.02	5.14	38.83	35.30	Average	100	155	HORIZONTAL

Vertical

	Freq	Level	Limit Line	Over Limit	Read Level	CableAntenna Loss	Antenna Factor	Preamp Factor	Remark	A/Pos	T/Pos	Pol/Phase
	MHz	dBuV/m	dBuV/m	dB	dBuV	dB	dB/m	dB		cm	deg	
1	5399.85	59.56	74.00	-14.44	57.01	3.51	34.12	35.08	Peak	100	89	VERTICAL
2	5399.97	50.07	54.00	-3.93	47.52	3.51	34.12	35.08	Average	100	89	VERTICAL
3	11589.75	36.82	54.00	-17.18	28.15	5.14	38.83	35.30	Average	100	234	VERTICAL
4	11590.33	48.58	74.00	-25.42	39.91	5.14	38.83	35.30	Peak	100	234	VERTICAL



Temperature	25°C	Humidity	54%
Test Engineer	Jim Huang	Configurations	IEEE 802.11n MCS16 20MHz CH 149 / 3TX / Chain 1 + Chain 2 + Chain 3
Test Date	Aug. 27, 2013	Test Mode	Mode 2 (Ant.31 PIFA antenna / 4.7dBi)

Horizontal

	Freq	Level	Limit	Over	Read	Cable	Antenna	Preamp	Remark	A/Pos	T/Pos	Pol/Phase
	MHz	dBuV/m	dBuV/m	dB	dBuV	dB	dB/m	dB		cm	deg	
1	11491.03	40.00	54.00	-14.00	31.39	5.11	38.78	35.28	Average	105	303	HORIZONTAL
2	11491.19	53.75	74.00	-20.25	45.14	5.11	38.78	35.28	Peak	105	303	HORIZONTAL

Vertical

	Freq	Level	Limit	Over	Read	Cable	Antenna	Preamp	Remark	A/Pos	T/Pos	Pol/Phase
	MHz	dBuV/m	dBuV/m	dB	dBuV	dB	dB/m	dB		cm	deg	
1	11488.46	58.34	74.00	-15.66	49.73	5.11	38.78	35.28	Peak	105	58	VERTICAL
2	11488.81	42.16	54.00	-11.84	33.55	5.11	38.78	35.28	Average	105	58	VERTICAL

Temperature	25°C	Humidity	54%
Test Engineer	Jim Huang	Configurations	IEEE 802.11n MCS16 20MHz CH 157 / 3TX / Chain 1 + Chain 2 + Chain 3
Test Date	Aug. 27, 2013	Test Mode	Mode 2 (Ant.31 PIFA antenna / 4.7dBi)

Horizontal

	Freq	Level	Limit Line	Over Limit	Read Level	CableAntenna Loss	Antenna Factor	Preamp Factor	Remark	A/Pos	T/Pos	Pol/Phase
	MHz	dBuV/m	dBuV/m	dB	dBuV	dB	dB/m	dB		cm	deg	
1	11564.84	49.92	74.00	-24.08	41.27	5.13	38.82	35.30	Peak	100	243	HORIZONTAL
2	11570.29	38.13	54.00	-15.87	29.46	5.14	38.83	35.30	Average	100	243	HORIZONTAL

Vertical

	Freq	Level	Limit Line	Over Limit	Read Level	CableAntenna Loss	Antenna Factor	Preamp Factor	Remark	A/Pos	T/Pos	Pol/Phase
	MHz	dBuV/m	dBuV/m	dB	dBuV	dB	dB/m	dB		cm	deg	
1	11566.79	40.00	54.00	-14.00	31.35	5.13	38.82	35.30	Average	100	56	VERTICAL
2	11568.62	54.55	74.00	-19.45	45.89	5.13	38.83	35.30	Peak	100	56	VERTICAL

Temperature	25°C	Humidity	54%
Test Engineer	Jim Huang	Configurations	IEEE 802.11n MCS16 20MHz CH 165 / 3TX / Chain 1 + Chain 2 + Chain 3
Test Date	Aug. 27, 2013	Test Mode	Mode 2 (Ant.31 PIFA antenna / 4.7dBi)

Horizontal

	Freq	Level	Limit Line	Over Limit	Read Level	CableAntenna Loss	Antenna Factor	Preamp Factor	Remark	A/Pos	T/Pos	Pol/Phase
	MHz	dBuV/m	dBuV/m	dB	dBuV	dB	dB/m	dB		cm	deg	
1	11645.74	50.05	74.00	-23.95	41.33	5.16	38.86	35.30	Peak	100	247	HORIZONTAL
2	11650.54	37.62	54.00	-16.38	28.90	5.16	38.86	35.30	Average	100	247	HORIZONTAL

Vertical

	Freq	Level	Limit Line	Over Limit	Read Level	CableAntenna Loss	Antenna Factor	Preamp Factor	Remark	A/Pos	T/Pos	Pol/Phase
	MHz	dBuV/m	dBuV/m	dB	dBuV	dB	dB/m	dB		cm	deg	
1	11641.76	50.65	74.00	-23.35	41.93	5.16	38.86	35.30	Peak	100	92	VERTICAL
2	11647.88	38.80	54.00	-15.20	30.08	5.16	38.86	35.30	Average	100	92	VERTICAL



Temperature	25°C	Humidity	54%
Test Engineer	Jim Huang	Configurations	IEEE 802.11n MCS16 40MHz CH 151 / 3TX / Chain 1 + Chain 2 + Chain 3
Test Date	Aug. 27, 2013	Test Mode	Mode 2 (Ant.31 PIFA antenna / 4.7dBi)

Horizontal

	Freq	Level	Limit	Over	Read	CableAntenna	Preamp	Remark	A/Pos	T/Pos	Pol/Phase
	MHz	dBuV/m	dBuV/m	dB	dBuV	Loss Factor	Factor		cm	deg	
1	11500.99	39.14	54.00	-14.86	30.51	5.12	38.79	35.28 Average	100	303	HORIZONTAL
2	11511.09	53.12	74.00	-20.88	44.49	5.12	38.79	35.28 Peak	100	303	HORIZONTAL

Vertical

	Freq	Level	Limit	Over	Read	CableAntenna	Preamp	Remark	A/Pos	T/Pos	Pol/Phase
	MHz	dBuV/m	dBuV/m	dB	dBuV	Loss Factor	Factor		cm	deg	
1	11501.09	39.49	54.00	-14.51	30.86	5.12	38.79	35.28 Average	100	61	VERTICAL
2	11511.03	55.43	74.00	-18.57	46.80	5.12	38.79	35.28 Peak	100	61	VERTICAL

Temperature	25°C	Humidity	54%
Test Engineer	Jim Huang	Configurations	IEEE 802.11n MCS16 40MHz CH 159 / 3TX / Chain 1 + Chain 2 + Chain 3
Test Date	Aug. 27, 2013	Test Mode	Mode 2 (Ant.31 PIFA antenna / 4.7dBi)

Horizontal

	Freq	Level	Limit	Over	Read	Cable	Antenna	Preamp	Remark	A/Pos	T/Pos	Pol/Phase
	MHz	dBuV/m	dBuV/m	dB	dBuV	dB	dB/m	dB		cm	deg	
1	11589.87	50.13	74.00	-23.87	41.46	5.14	38.83	35.30	Peak	100	197	HORIZONTAL
2	11597.37	37.56	54.00	-16.44	28.88	5.15	38.83	35.30	Average	100	197	HORIZONTAL

Vertical

	Freq	Level	Limit	Over	Read	Cable	Antenna	Preamp	Remark	A/Pos	T/Pos	Pol/Phase
	MHz	dBuV/m	dBuV/m	dB	dBuV	dB	dB/m	dB		cm	deg	
1	11586.44	38.10	54.00	-15.90	29.43	5.14	38.83	35.30	Average	100	131	VERTICAL
2	11597.02	51.42	74.00	-22.58	42.74	5.15	38.83	35.30	Peak	100	131	VERTICAL

Temperature	25°C	Humidity	54%
Test Engineer	Jim Huang	Configurations	IEEE 802.11a CH 149 / 1TX / Chain 1
Test Date	Sep. 27, 2013	Test Mode	Mode 2 (Ant.31 PIFA antenna / 4.7dBi)

Horizontal

	Freq	Level	Limit Line	Over Limit	Read Level	CableAntenna Loss	Antenna Factor	Preamp Factor	Remark	A/Pos	T/Pos	Pol/Phase
	MHz	dBuV/m	dBuV/m	dB	dBuV	dB	dB/m	dB		cm	deg	
1	11481.70	53.17	74.00	-20.83	44.57	5.11	38.77	35.28	Peak	100	75	HORIZONTAL
2	11491.57	39.72	54.00	-14.28	31.11	5.11	38.78	35.28	Average	100	75	HORIZONTAL

Vertical

	Freq	Level	Limit Line	Over Limit	Read Level	CableAntenna Loss	Antenna Factor	Preamp Factor	Remark	A/Pos	T/Pos	Pol/Phase
	MHz	dBuV/m	dBuV/m	dB	dBuV	dB	dB/m	dB		cm	deg	
1	11486.25	38.68	54.00	-15.32	30.07	5.11	38.78	35.28	Average	100	190	VERTICAL
2	11492.40	50.69	74.00	-23.31	42.08	5.11	38.78	35.28	Peak	100	190	VERTICAL



Temperature	25°C	Humidity	54%
Test Engineer	Jim Huang	Configurations	IEEE 802.11a CH 157 / 1TX / Chain 1
Test Date	Sep. 27, 2013	Test Mode	Mode 2 (Ant.31 PIFA antenna / 4.7dBi)

Horizontal

	Freq	Level	Limit Line	Over Limit	Read Level	CableAntenna Loss	Antenna Factor	Preamp Factor	Remark	A/Pos	T/Pos	Pol/Phase
	MHz	dBuV/m	dBuV/m	dB	dBuV	dB	dB/m	dB		cm	deg	
1	11571.15	39.58	54.00	-14.42	30.91	5.14	38.83	35.30	Average	100	70	HORIZONTAL
2	11571.60	52.04	74.00	-21.96	43.37	5.14	38.83	35.30	Peak	100	70	HORIZONTAL

Vertical

	Freq	Level	Limit Line	Over Limit	Read Level	CableAntenna Loss	Antenna Factor	Preamp Factor	Remark	A/Pos	T/Pos	Pol/Phase
	MHz	dBuV/m	dBuV/m	dB	dBuV	dB	dB/m	dB		cm	deg	
1	11564.46	52.21	74.00	-21.79	43.56	5.13	38.82	35.30	Peak	100	272	VERTICAL
2	11565.96	39.44	54.00	-14.56	30.79	5.13	38.82	35.30	Average	100	272	VERTICAL

Temperature	25°C	Humidity	54%
Test Engineer	Jim Huang	Configurations	IEEE 802.11a CH 165 / 1TX / Chain 1
Test Date	Sep. 27, 2013	Test Mode	Mode 2 (Ant.31 PIFA antenna / 4.7dBi)

Horizontal

	Freq	Level	Limit	Over	Read	Cable	Antenna	Preamp	Remark	A/Pos	T/Pos	Pol/Phase
	MHz	dBuV/m	dBuV/m	dB	dBuV	dB	dB/m	dB		cm	deg	
1	11651.73	39.37	54.00	-14.63	30.65	5.16	38.86	35.30	Average	100	62	HORIZONTAL
2	11656.15	52.48	74.00	-21.52	43.76	5.16	38.86	35.30	Peak	100	62	HORIZONTAL

Vertical

	Freq	Level	Limit	Over	Read	Cable	Antenna	Preamp	Remark	A/Pos	T/Pos	Pol/Phase
	MHz	dBuV/m	dBuV/m	dB	dBuV	dB	dB/m	dB		cm	deg	
1	11643.21	51.23	74.00	-22.77	42.51	5.16	38.86	35.30	Peak	100	294	VERTICAL
2	11651.41	39.34	54.00	-14.66	30.62	5.16	38.86	35.30	Average	100	294	VERTICAL

Note:

The amplitude of spurious emissions that are attenuated by more than 20dB below the permissible value has no need to be reported.

Emission level (dBuV/m) = 20 log Emission level (uV/m).

Corrected Reading: Antenna Factor + Cable Loss + Read Level - Preamp Factor = Level.