



FCC RADIO TEST REPORT

FCC ID : UZ7ET56DT
Equipment : Tablet
Brand Name : Zebra
Model Name : ET56DT
Applicant : Zebra Technologies Corporation
1 Zebra Plaza, Holtsville, NY 11742
Manufacturer : Zebra Technologies Corporation
1 Zebra Plaza, Holtsville, NY 11742
Standard : FCC Part 15 Subpart E §15.407

The product was received on Aug. 05, 2020 and testing was started from Aug. 07, 2020 and completed on Sep. 08, 2020. We, SPORTON INTERNATIONAL INC., EMC & Wireless Communications Laboratory, would like to declare that the tested sample has been evaluated in accordance with the test procedures and has been in compliance with the applicable technical standards.

The test results in this report apply exclusively to the tested model / sample. Without written approval of SPORTON INTERNATIONAL INC. EMC & Wireless Communications Laboratory, the test report shall not be reproduced except in full.

Louis Wu

Approved by: Louis Wu

SPORTON INTERNATIONAL INC. EMC & Wireless Communications Laboratory

No. 52, Huaya 1st Rd., Guishan Dist., Taoyuan City, Taiwan (R.O.C.)



Table of Contents

History of this test report.....	3
Summary of Test Result.....	4
1 General Description	5
1.1 Product Feature of Equipment Under Test.....	5
1.2 Product Specification of Equipment Under Test.....	5
1.3 Modification of EUT	6
1.4 Testing Location	6
1.5 Applicable Standards.....	6
2 Test Configuration of Equipment Under Test	7
2.1 Carrier Frequency and Channel	7
2.2 Test Mode.....	7
2.3 Connection Diagram of Test System.....	7
2.4 Support Unit used in test configuration and system	8
2.5 EUT Operation Test Setup	8
3 Test Result	9
3.1 Unwanted Emissions Measurement.....	9
3.2 Antenna Requirements	14
4 List of Measuring Equipment.....	15
5 Uncertainty of Evaluation	16
Appendix A. Radiated Spurious Emission	
Appendix B. Radiated Spurious Emission Plots	
Appendix C. Duty Cycle Plots	
Appendix D. Setup Photographs	



History of this test report

Report No.	Version	Description	Issued Date
FR072903-01G	01	Initial issue of report	Sep. 16, 2020



Summary of Test Result

Report Clause	Ref Std. Clause	Test Items	Result (PASS/FAIL)	Remark
3.1	15.407(b)	Unwanted Emissions	Pass	Under limit 2.28 dB at 2389.905 MHz
3.2	15.203 15.407(a)	Antenna Requirement	Pass	-

Declaration of Conformity: The test results with all measurement uncertainty excluded are presented in accordance with the regulation limits or requirements declared by manufacturers.
Comments and Explanations: The declared of product specification for EUT presented in the report are provided by the manufacturer, and the manufacturer takes all the responsibilities for the accuracy of product specification.

Reviewed by: **Wii Chang**
Report Producer: **Vivian Hsu**

1 General Description

1.1 Product Feature of Equipment Under Test

Product Feature	
Equipment	Tablet
Brand Name	Zebra
Model Name	ET56DT
FCC ID	UZ7ET56DT
EUT supports Radios application	WCDMA/HSPA/LTE/NFC/GNSS WLAN 11a/b/g/n HT20/HT40 WLAN 11ac VHT20/VHT40/VHT80 Bluetooth BR/EDR/LE
HW Version	DV1
SW Version	Android 10
FW Version	10-13-05.00-QG-U00-PRD-HEL-04
MFD	15JUL20
EUT Stage	Identical Prototype

Remark: The above EUT's information was declared by manufacturer.

Specification of Accessories				
Spare Standard Battery 36.75Wh	Brand Name	Zebra	Part Number	BT-000394

Supported Unit Used in Test Configuration and System				
Cradle (Dock) for EMC	Brand Name	Zebra	Part Number	CRD-ET5X-1SCG1
Cradle (Dock) for RSE	Brand Name	Zebra	Part Number	CHG-ET5X-CBL1-01
Adapter for Cradle	Brand Name	Zebra	Part Number	PWRBGA12V50W0WW
DC Cable for Cradle	Brand Name	Zebra	Part Number	CBL-DC-388A1-01
USB Cable	Brand Name	Zebra	Part Number	CBL-TC2X-USBC-01
Adapter	Brand Name	Zebra	Part Number	PWR-WUA5V12W0US

1.2 Product Specification of Equipment Under Test

Product Specification subjective to this standard	
Tx/Rx Frequency Range	2412 MHz ~ 2462 MHz 5180 MHz ~ 5240 MHz
Antenna Type / Gain	<2412 MHz ~ 2462 MHz> Ant. 1 : Chip Antenna with gain 0.85 dBi <5180 MHz ~ 5240 MHz> Ant. 1 : Chip Antenna with gain 3.06 dBi Ant. 2 : Chip Antenna with gain 2.24 dBi
Type of Modulation	802.11n : OFDM (BPSK / QPSK / 16QAM / 64QAM) 802.11ac: OFDM (BPSK / QPSK / 16QAM / 64QAM / 256QAM)



1.3 Modification of EUT

No modifications are made to the EUT during all test items.

1.4 Testing Location

Test Site	SPORTON INTERNATIONAL INC. EMC & Wireless Communications Laboratory
Test Site Location	No.58, Aly. 75, Ln. 564, Wenhua 3rd, Rd., Guishan Dist., Taoyuan City, Taiwan (R.O.C.) TEL: +886-3-327-0868 FAX: +886-3-327-0855
Test Site No.	Sporton Site No. 03CH15-HY

Note: The test site complies with ANSI C63.4 2014 requirement.

FCC designation No.: TW0007

1.5 Applicable Standards

According to the specifications of the manufacturer, the EUT must comply with the requirements of the following standards:

- ♦ FCC Part 15 Subpart E
- ♦ FCC KDB Publication No. 558074 D01 DTS Meas. Guidance v05r02
- ♦ FCC KDB 789033 D02 General UNII Test Procedures New Rules v02r01.
- ♦ FCC KDB 414788 D01 Radiated Test Site v01r01.
- ♦ FCC KDB 662911 D01 Multiple Transmitter Output v02r01.
- ♦ ANSI C63.10-2013

Remark:

1. All test items were verified and recorded according to the standards and without any deviation during the test.
2. The TAF code is not including all the FCC KDB listed without accreditation.
3. This EUT has also been tested and complied with the requirements of FCC Part 15, Subpart B, recorded in a separate test report.

2 Test Configuration of Equipment Under Test

- a. The EUT has been associated with peripherals and configuration operated in a manner tended to maximize its emission characteristics in a typical application. Frequency range investigated: radiation emission (9 kHz to the 10th harmonic of the highest fundamental frequency or to 40 GHz, whichever is lower). For radiated measurement, pre-scanned in three orthogonal panels, X, Y, Z. The worst cases (X plane) were recorded in this report.

2.1 Carrier Frequency and Channel

2400-2483.5 MHz 802.11n HT20		5150-5250 MHz 802.11ac VHT80	
Channel	Freq. (MHz)	Channel	Freq. (MHz)
01	2412	42	5210

2.2 Test Mode

Final test modes are considering the modulation and worse data rates as below table.

<Co-Location>

Modulation	Data Rate
802.11n HT20 for Ant. 1 + 802.11ac VHT80 for MIMO <Ant. 1+2>	MCS0 + MCS0

2.3 Connection Diagram of Test System

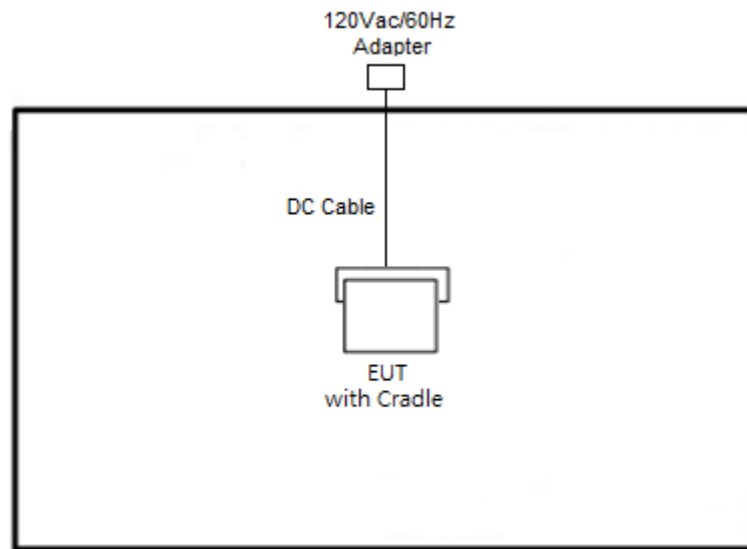



2.4 Support Unit used in test configuration and system

Item	Equipment	Brand Name	Model Name	FCC ID	Data Cable	Power Cord
1.	Notebook	Lenovo	L570	FCC DoC	N/A	AC I/P: Unshielded, 1.2 m DC O/P: Shielded, 1.8 m

2.5 EUT Operation Test Setup

The RF test items, utility “QRCT v3.0.303.0” was installed in Notebook which was programmed in order to make the EUT get into the engineering modes to provide channel selection, power level, data rate and the application type and for continuous transmitting signals.



3 Test Result

3.1 Unwanted Emissions Measurement

This section is to measure unwanted emissions through radiated measurement for band edge spurious emissions and out of band emissions measurement.

3.1.1 Limit of Unwanted Emissions

- (1) Unwanted spurious emissions fallen in restricted bands shall comply with the general field strength limits as below table:

Frequency (MHz)	Field Strength (microvolts/meter)	Measurement Distance (meters)
0.009 – 0.490	2400/F(kHz)	300
0.490 – 1.705	24000/F(kHz)	30
1.705 – 30.0	30	30
30 – 88	100	3
88 – 216	150	3
216 - 960	200	3
Above 960	500	3

Note: The following formula is used to convert the EIRP to field strength.

$$E = \frac{1000000\sqrt{30P}}{3} \mu V/m, \text{ where } P \text{ is the eirp (Watts)}$$

EIRP (dBm)	Field Strength at 3m (dBμV/m)
- 27	68.3

- (2) KDB789033 D02 v02r01 G)2)c)
 - (i) Sections 15.407(b)(1-3) specifies the unwanted emissions limit for the U-NII-1 and U-NII-2 bands. As specified, emissions above 1000 MHz that are outside of the restricted bands are subject to a peak emission limit of -27 dBm/MHz.
 - (ii) Section 15.407(b)(4) specifies the unwanted emissions limit for the U-NII-3 band. A band emissions mask is specified in Section 15.407(b)(4)(i). The emission limits are based on the use of a peak detector.

3.1.2 Measuring Instruments

See list of measuring equipment of this test report.



3.1.3 Test Procedures

1. The testing follows FCC KDB 789033 D02 General UNII Test Procedures New Rules v02r01. Section G) Unwanted emissions measurement.
 - (1) Procedure for Unwanted Emissions Measurements Below 1000MHz
 - RBW = 120 kHz
 - VBW = 300 kHz
 - Detector = Peak
 - Trace mode = max hold
 - (2) Procedure for Peak Unwanted Emissions Measurements Above 1000 MHz
 - RBW = 1 MHz
 - VBW \geq 3 MHz
 - Detector = Peak
 - Sweep time = auto
 - Trace mode = max hold
 - (3) Procedures for Average Unwanted Emissions Measurements Above 1000MHz
 - RBW = 1 MHz
 - VBW = 10 Hz, when duty cycle is no less than 98 percent.
 - VBW \geq 1/T, when duty cycle is less than 98 percent where T is the minimum transmission duration over which the transmitter is on and is transmitting at its maximum power control level for the tested mode of operation.
2. The EUT was placed on a turntable with 0.8 meter for frequency below 1GHz and 1.5 meter for frequency above 1GHz respectively above ground.
3. The EUT was set 3 meters from the interference receiving antenna which was mounted on the top of a variable height antenna tower.
4. The antenna is a broadband antenna and its height is adjusted between one meter and four meters above ground to find the maximum value of the field strength for both horizontal polarization and vertical polarization of the antenna.
5. For each suspected emission, the EUT was arranged to its worst case and then adjust the antenna tower (from 1 m to 4 m) and turntable (from 0 degree to 360 degrees) to find the maximum reading.
6. For testing below 1GHz, if the emission level of the EUT in peak mode was 3 dB lower than the limit specified, then peak values of EUT will be reported, otherwise, the emissions will be repeated one by one using the CISPR quasi-peak method and reported.
7. For testing above 1GHz, the emission level of the EUT in peak mode was 20dB lower than average limit (that means the emission level in average mode also complies with the limit in average mode), then peak values of EUT will be reported, otherwise, the emissions will be measured in average mode again and reported.

3.1.4 Test Setup

For radiated emissions below 30MHz

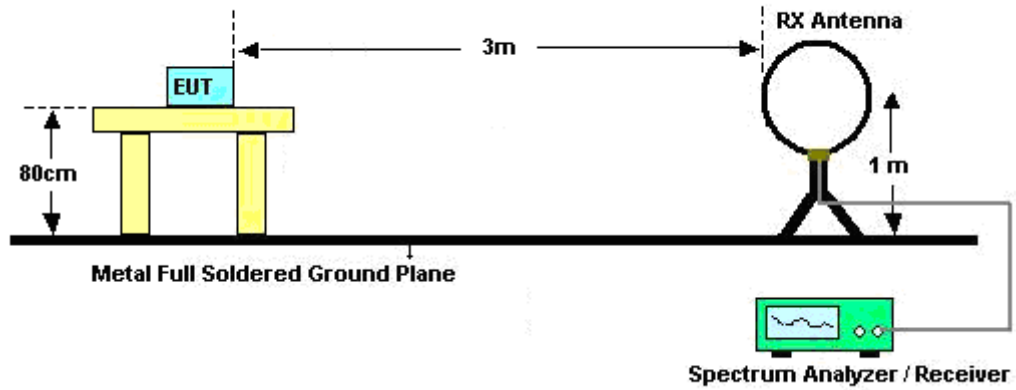

For radiated emissions from 30MHz to 1GHz

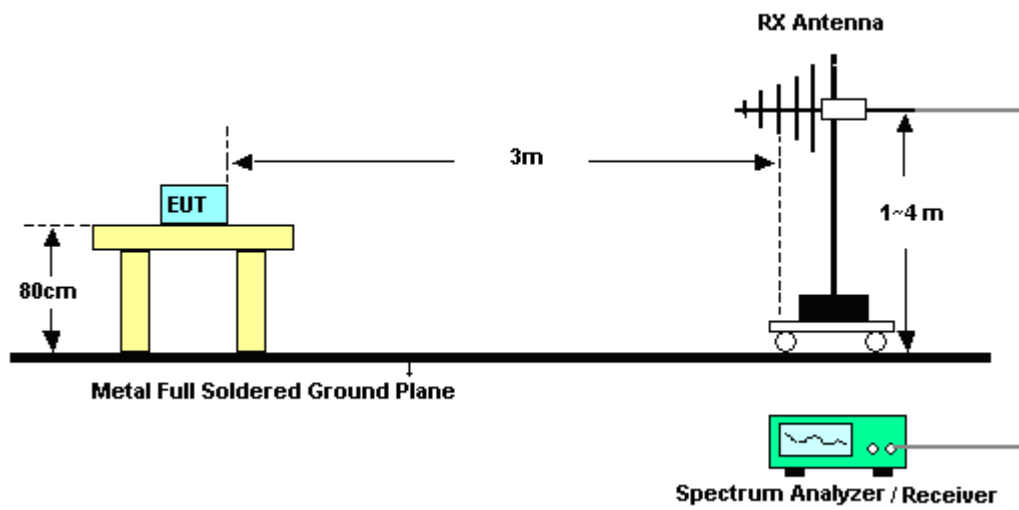

For radiated emissions from 1GHz to 18GHz

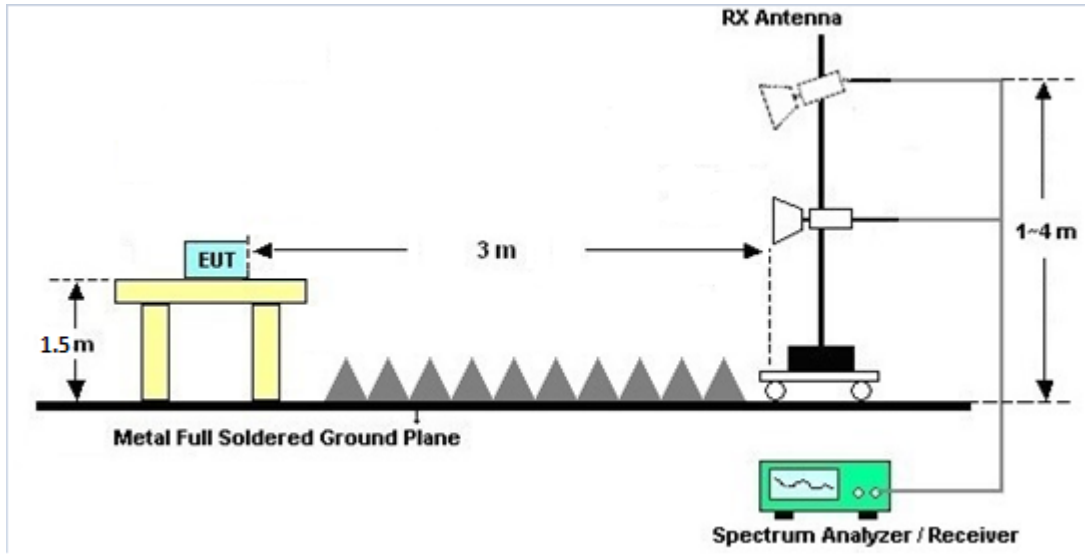

For radiated emissions above 18GHz

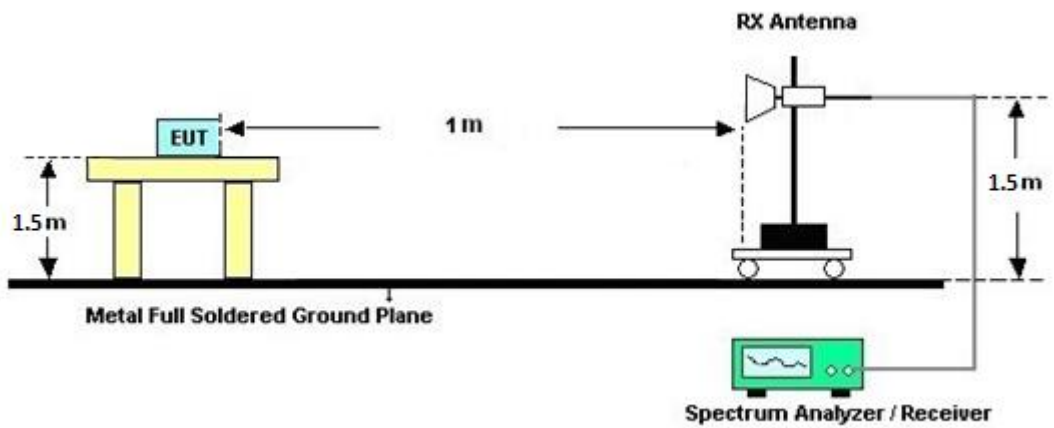



3.1.5 Test Results of Radiated Spurious Emissions (9 kHz ~ 30 MHz)

The low frequency, which started from 9 kHz to 30MHz, was pre-scanned and the result which was 20dB lower than the limit line was not reported.

There is a comparison data of both open-field test site and alternative test site - semi-Anechoic chamber according to 414788 D01 Radiated Test Site v01r01, and the result came out very similar.

3.1.6 Test Result of Radiated Spurious at Band Edges

Please refer to Appendix A and B.

3.1.7 Duty Cycle

Please refer to Appendix C.

3.1.8 Test Result of Radiated Spurious Emissions (30MHz ~ 10th Harmonic)

Please refer to Appendix A and B.



3.2 Antenna Requirements

3.2.1 Standard Applicable

If transmitting antenna directional gain is greater than 6 dBi, both the peak transmit power and the peak power spectral density shall be reduced by the amount in dB that the directional gain of the antenna exceeds 6 dBi.

3.2.2 Antenna Anti-Replacement Construction

An embedded-in antenna design is used.

3.2.3 Antenna Gain

The antenna peak gain of EUT is less than 6 dBi. Therefore, it is not necessary to reduce maximum peak output power limit.



4 List of Measuring Equipment

Instrument	Brand Name	Model No.	Serial No.	Characteristics	Calibration Date	Test Date	Due Date	Remark
Loop Antenna	Rohde & Schwarz	HFH2-Z2	100488	9 kHz~30 MHz	Jan. 09, 2020	Aug. 07, 2020~ Sep. 08, 2020	Jan. 08, 2021	Radiation (03CH15-HY)
Bilog Antenna	TESEQ	CBL6111D& 00800N1D0 1N-06	41912&05	30MHz to 1GHz	Feb. 09, 2020	Aug. 07, 2020~ Sep. 08, 2020	Feb. 08, 2021	Radiation (03CH15-HY)
Amplifier	SONOMA	310N	363440	9kHz~1GHz	Dec. 27, 2019	Aug. 07, 2020~ Sep. 08, 2020	Dec. 26, 2020	Radiation (03CH15-HY)
Horn Antenna	SCHWARZBE CK	BBHA 9120 D	9120D-1620	1-18GHz	Oct. 28, 2019	Aug. 07, 2020~ Sep. 08, 2020	Oct. 27, 2020	Radiation (03CH15-HY)
SHF-EHF Horn Antenna	SCHWARZBE CK	BBHA 9170	BBHA917058 4	18GHz- 40GHz	Dec. 10, 2019	Aug. 07, 2020~ Sep. 08, 2020	Dec. 09, 2020	Radiation (03CH15-HY)
Preamplifier	Jet-Power	JPA0118-55- 303	1710001800 055006	1GHz~18GHz	May 07, 2020	Aug. 07, 2020~ Sep. 08, 2020	May 06, 2021	Radiation (03CH15-HY)
Preamplifier	Keysight	83017A	MY53270195	1GHz~26.5GHz	Aug. 23, 2019	Aug. 07, 2020~ Aug. 21, 2020	Aug. 22, 2020	Radiation (03CH15-HY)
Preamplifier	Keysight	83017A	MY53270195	1GHz~26.5GHz	Aug. 21, 2020	Aug. 21, 2020~ Sep. 08, 2020	Aug. 20, 2021	Radiation (03CH15-HY)
Preamplifier	EMEC	EM18G40G	060715	18GHz ~ 40GHz	Dec. 13, 2019	Aug. 07, 2020~ Sep. 08, 2020	Dec. 12, 2020	Radiation (03CH15-HY)
EMI Test Receiver	Keysight	N9038A(MX E)	MY54130085	20MHz~8.4GHz	Nov. 01, 2019	Aug. 07, 2020~ Sep. 08, 2020	Oct. 31, 2020	Radiation (03CH15-HY)
Spectrum Analyzer	Agilent	E4446A	MY50180136	3Hz~44GHz	May 04, 2020	Aug. 07, 2020~ Sep. 08, 2020	May 03, 2021	Radiation (03CH15-HY)
Antenna Mast	ChainTek	MBS-520-1	N/A	1m~4m	N/A	Aug. 07, 2020~ Sep. 08, 2020	N/A	Radiation (03CH15-HY)
Turn Table	ChainTek	T-200-S-1	N/A	0~360 Degree	N/A	Aug. 07, 2020~ Sep. 08, 2020	N/A	Radiation (03CH15-HY)
Software	Audix	E3 6.2009-8-24(k5)	RK-000451	N/A	N/A	Aug. 07, 2020~ Sep. 08, 2020	N/A	Radiation (03CH15-HY)
RF Cable	HUBER + SUHNER	SUCOFLEX 104	MY36980/4	30M-18G	Apr. 14, 2020	Aug. 07, 2020~ Sep. 08, 2020	Apr. 13, 2021	Radiation (03CH15-HY)
RF Cable	HUBER + SUHNER	SUCOFLEX 104	MY9838/4PE	30M-18G	Apr. 14, 2020	Aug. 07, 2020~ Sep. 08, 2020	Apr. 13, 2021	Radiation (03CH15-HY)
RF Cable	HUBER + SUHNER	SUCOFLEX 104	MY37710/4	30M-18G	Apr. 17, 2020	Aug. 07, 2020~ Sep. 08, 2020	Apr. 16, 2021	Radiation (03CH15-HY)
RF Cable	HUBER + SUHNER	SUCOFLEX 102	505134/2	30MHz-40GHz	Feb. 25, 2020	Aug. 07, 2020~ Sep. 08, 2020	Feb. 24, 2021	Radiation (03CH15-HY)
RF Cable	HUBER + SUHNER	SUCOFLEX 102	800740/2	30MHz-40GHz	Feb. 25, 2020	Aug. 07, 2020~ Sep. 08, 2020	Feb. 24, 2021	Radiation (03CH15-HY)
RF Cable	HUBER + SUHNER	SUCOFLEX 104	MY9837/4PE	9kHz~30MHz	Mar. 12, 2020	Aug. 07, 2020~ Sep. 08, 2020	Mar. 11, 2021	Radiation (03CH15-HY)
Filter	Wainwright	WLK4-1000- 1530-8000-4 0SS	SN4	1.53G Low Pass	Jul. 03, 2020	Aug. 07, 2020~ Sep. 08, 2020	Jul. 02, 2021	Radiation (03CH15-HY)
Filter	Wainwright	WHKX8-587 2.5-6750-18 000-40ST	SN6	6.75GHz High Pass Filter	Jul. 03, 2020	Aug. 07, 2020~ Sep. 08, 2020	Jul. 02, 2021	Radiation (03CH15-HY)
Filter	Wainwright	WHKX12-27 00-3000-180 00-60ST	SN4	3GHz High Pass Filter	Sep. 17, 2019	Aug. 07, 2020~ Sep. 08, 2020	Sep. 16, 2020	Radiation (03CH15-HY)



5 Uncertainty of Evaluation

Uncertainty of Radiated Emission Measurement (30 MHz ~ 1000 MHz)

Measuring Uncertainty for a Level of Confidence of 95% ($U = 2Uc(y)$)	5.0
---	-----

Uncertainty of Radiated Emission Measurement (1000 MHz ~ 18000 MHz)

Measuring Uncertainty for a Level of Confidence of 95% ($U = 2Uc(y)$)	5.4
---	-----

Uncertainty of Radiated Emission Measurement (18000 MHz ~ 40000 MHz)

Measuring Uncertainty for a Level of Confidence of 95% ($U = 2Uc(y)$)	5.0
---	-----



Appendix A. Radiated Spurious Emission

Test Engineer :	Leo Lee, Mancy Chou and Bigshow Wang	Temperature :	22.1~23.1°C
		Relative Humidity :	48~58%

11n(20)_Tx_Ch01+11ac(80)_Tx_Ch42 (Band Edge @ 3m)

WIFI Ant. Simultaneously	Note	Frequency (MHz)	Level (dBμV/m)	Over Limit (dB)	Limit Line (dBμV/m)	Read Level (dBμV)	Antenna Factor (dB/m)	Path Loss (dB)	Preamp Factor (dB)	Ant Pos (cm)	Table Pos (deg)	Peak Avg. (P/A)	Pol. (H/V)	
11n(20)_Tx_Ch01 Ant 1 + 11ac(80)_Tx_Ch42 Ant 1+2		2390	66.61	-7.39	74	52.42	27.76	17.35	30.92	100	118	P	H	
		2389.905	51.72	-2.28	54	37.53	27.76	17.35	30.92	100	118	A	H	
	*	2412	105.31	-	-	91.15	27.68	17.39	30.91	100	118	P	H	
	*	2412	97.59	-	-	83.43	27.68	17.39	30.91	100	118	A	H	
													H	
														H
			2390	64.15	-9.85	74	49.96	27.76	17.35	30.92	371	280	P	V
			2390	50.48	-3.52	54	36.29	27.76	17.35	30.92	371	280	A	V
	*		2412	104.54	-	-	90.38	27.68	17.39	30.91	371	280	P	V
	*		2412	96.57	-	-	82.41	27.68	17.39	30.91	371	280	A	V
														V
														V
11n(20)_Tx_Ch01 Ant 1 + 11ac(80)_Tx_Ch42 Ant 1+2		5147.16	54.71	-19.29	74	42.14	32.09	10.49	30.01	333	232	P	H	
		5146.64	45.99	-8.01	54	33.42	32.09	10.49	30.01	333	232	A	H	
	*	5210	100.24	-	-	87.94	31.74	10.57	30.01	333	232	P	H	
	*	5210	92.64	-	-	80.34	31.74	10.57	30.01	333	232	A	H	
		5424.44	51.31	-22.69	74	38.91	31.7	10.69	29.99	333	232	P	H	
		5437.88	43.18	-10.82	54	30.76	31.7	10.71	29.99	333	232	A	H	
		5142.22	56.91	-17.09	74	44.36	32.08	10.48	30.01	266	20	P	V	
		5143.78	47.89	-6.11	54	35.32	32.09	10.49	30.01	266	20	A	V	
	*	5210	103.31	-	-	91.01	31.74	10.57	30.01	266	20	P	V	
	*	5210	95.64	-	-	83.34	31.74	10.57	30.01	266	20	A	V	
		5395.04	51.6	-22.4	74	39.27	31.67	10.66	30	266	20	P	V	
		5419.4	43.32	-10.68	54	30.93	31.7	10.68	29.99	266	20	A	V	
Remark	1. No other spurious found. 2. All results are PASS against Peak and Average limit line.													



11n(20)_Tx_Ch01+11ac(80)_Tx_Ch42 (Harmonic @ 3m)

WIFI Ant. Simultaneously	Note	Frequency (MHz)	Level (dBμV/m)	Over Limit (dB)	Limit Line (dBμV/m)	Read Level (dBμV)	Antenna Factor (dB/m)	Path Loss (dB)	Preamp Factor (dB)	Ant Pos (cm)	Table Pos (deg)	Peak Avg. (P/A)	Pol. (H/V)	
11n(20)_Tx_Ch0 1 Ant 1 + 11ac(80)_Tx_Ch 42 Ant 1+2		4824	45.91	-28.09	74	63.08	31.25	10.67	59.09	100	0	P	H	
		10420	49.79	-24.21	74	56.37	40.1	14.31	60.99	100	0	P	H	
		15630	46.06	-27.94	74	53.48	37.64	17.22	62.28	100	0	P	H	
													H	
													H	
													H	
													H	
													H	
													H	
													H	
			4824	46.23	-27.77	74	63.4	31.25	10.67	59.09	100	0	P	V
			10420	49.13	-24.87	74	55.71	40.1	14.31	60.99	100	0	P	V
			15630	46.91	-27.09	74	54.33	37.64	17.22	62.28	100	0	P	V
														V
													V	
													V	
													V	
													V	
Remark	1. No other spurious found. 2. All results are PASS against Peak and Average limit line.													



Emission below 1GHz

11n(20)_Tx_Ch01+11ac(80)_Tx_Ch42 (LF @ 3m)

WIFI	Note	Frequency	Level	Over	Limit	Read	Antenna	Path	Preamp	Ant	Table	Peak	Pol.	
Ant.				Limit	Line	Level	Factor	Loss	Factor	Pos	Pos	Avg.		
Simultaneously		(MHz)	(dBμV/m)	(dB)	(dBμV/m)	(dBμV)	(dB/m)	(dB)	(dB)	(cm)	(deg)	(P/A)	(H/V)	
11n(20)_Tx_Ch01 Ant 1 + 11ac(80)_Tx_Ch42 Ant 1+2		87.23	21.94	-18.06	40	38.53	14.53	1.27	32.39	-	-	P	H	
		110.51	24.82	-18.68	43.5	38.67	17.06	1.44	32.35	-	-	P	H	
		236.61	29.7	-16.3	46	43.29	16.61	2.2	32.4	-	-	P	H	
		471.35	32.85	-13.15	46	39.07	23.32	2.98	32.52	-	-	P	H	
		491.72	32.19	-13.81	46	37.86	23.69	3.1	32.46	-	-	P	H	
		898.15	38.58	-7.42	46	37.66	28.57	4.3	31.95	100	0	P	H	
														H
														H
														H
														H
														H
														H
			31.94	26.77	-13.23	40	36.53	21.84	0.73	32.33	-	-	P	V
			100.81	28.77	-14.73	43.5	43.37	16.32	1.36	32.28	-	-	P	V
			235.64	27.79	-18.21	46	41.49	16.5	2.2	32.4	-	-	P	V
			473.29	31.76	-14.24	46	37.94	23.35	2.99	32.52	-	-	P	V
			745.86	34.4	-11.6	46	35.39	27.65	3.82	32.46	-	-	P	V
			900.09	38.1	-7.9	46	37.2	28.56	4.3	31.96	100	0	P	V
														V
														V
													V	
													V	
													V	
													V	
Remark	1. No other spurious found. 2. All results are PASS against limit line.													



Note symbol

*	Fundamental Frequency which can be ignored. However, the level of any unwanted emissions shall not exceed the level of the fundamental frequency.
!	Test result is over limit line.
P/A	Peak or Average
H/V	Horizontal or Vertical



A calculation example for radiated spurious emission is shown as below:

WIFI	Note	Frequency	Level	Over	Limit	Read	Antenna	Path	Preamp	Ant	Table	Peak	Pol.
Ant.				Limit	Line	Level	Factor	Loss	Factor	Pos	Pos	Avg.	
1		(MHz)	(dBμV/m)	(dB)	(dBμV/m)	(dBμV)	(dB/m)	(dB)	(dB)	(cm)	(deg)	(P/A)	(H/V)
802.11b		2390	55.45	-18.55	74	54.51	32.22	4.58	35.86	103	308	P	H
CH 01													
2412MHz		2390	43.54	-10.46	54	42.6	32.22	4.58	35.86	103	308	A	H

1. Path Loss(dB) = Cable loss(dB) + Filter loss(dB) + Attenuator loss(dB)
2. Level(dBμV/m) =
Antenna Factor(dB/m) + Path Loss(dB) + Read Level(dBμV) - Preamp Factor(dB)
3. Over Limit(dB) = Level(dBμV/m) – Limit Line(dBμV/m)

For Peak Limit @ 2390MHz:

1. Level(dBμV/m)
= Antenna Factor(dB/m) + Path Loss(dB) + Read Level(dBμV) - Preamp Factor(dB)
= 32.22(dB/m) + 4.58(dB) + 54.51(dBμV) – 35.86 (dB)
= 55.45 (dBμV/m)
2. Over Limit(dB)
= Level(dBμV/m) – Limit Line(dBμV/m)
= 55.45(dBμV/m) – 74(dBμV/m)
= -18.55(dB)

For Average Limit @ 2390MHz:

1. Level(dBμV/m)
= Antenna Factor(dB/m) + Path Loss(dB) + Read Level(dBμV) - Preamp Factor(dB)
= 32.22(dB/m) + 4.58(dB) + 42.6(dBμV) – 35.86 (dB)
= 43.54 (dBμV/m)
2. Over Limit(dB)
= Level(dBμV/m) – Limit Line(dBμV/m)
= 43.54(dBμV/m) – 54(dBμV/m)
= -10.46(dB)

Both peak and average measured complies with the limit line, so test result is “PASS”.



Appendix B. Radiated Spurious Emission Plots

Test Engineer :	Leo Lee, Mancy Chou and Bigshow Wang	Temperature :	22.1~23.1°C
		Relative Humidity :	48~58%

Note symbol

-L	Low channel location
-R	High channel location

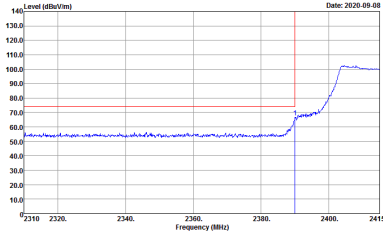
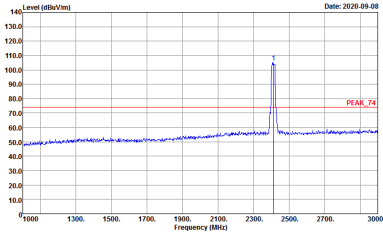
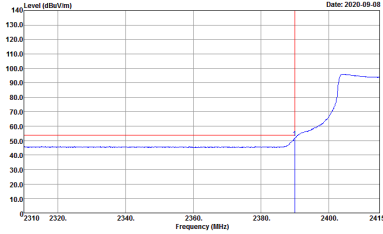
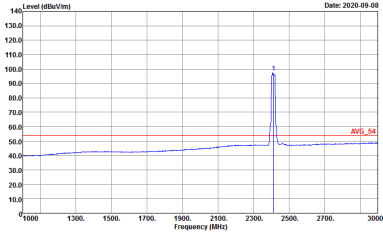

11n(20)_Tx_Ch01+11ac(80)_Tx_Ch42 (Band Edge @ 3m)

ANT	11n(20)_Tx_Ch01 - L	
1	Horizontal	Fundamental
Peak	 <p>Date: 2020-09-08</p> <p>Site : 03CH15-HY Condition : PEAK_BE_74 3m 9120D_15_1620 HORIZONTAL : RBW:1000.000KHz VBW:3000.000KHz SWT:Auto Detector : Peak Project : 072903-01 2.46 Setting : 13.5 5c Setting : 17.5</p>	 <p>Date: 2020-09-08</p> <p>Site : 03CH15-HY Condition : PEAK_74 3m 9120D_15_1620 HORIZONTAL : RBW:1000.000KHz VBW:3000.000KHz SWT:Auto Detector : Peak Project : 072903-01 2.46 Setting : 13.5 5c Setting : 17.5</p>
Avg.	 <p>Date: 2020-09-08</p> <p>Site : 03CH15-HY Condition : AVG_BE_54 3m 9120D_15_1620 HORIZONTAL : RBW:1000.000KHz VBW:1.000KHz SWT:Auto Detector : Peak Project : 072903-01 2.46 Setting : 13.5 5c Setting : 17.5</p>	 <p>Date: 2020-09-08</p> <p>Site : 03CH15-HY Condition : AVG_54 3m 9120D_15_1620 HORIZONTAL : RBW:1000.000KHz VBW:1.000KHz SWT:Auto Detector : Peak Project : 072903-01 2.46 Setting : 13.5 5c Setting : 17.5</p>

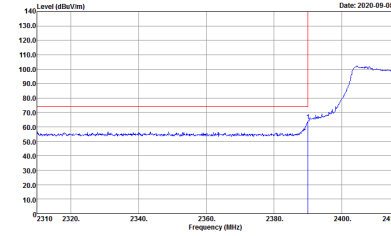
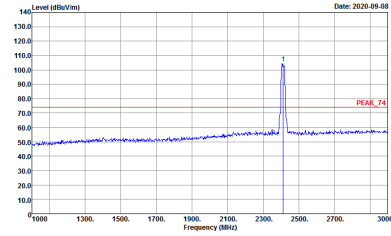
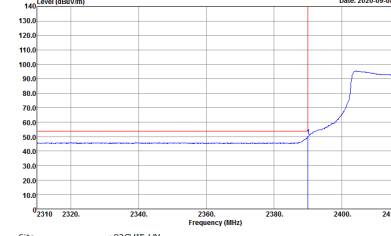
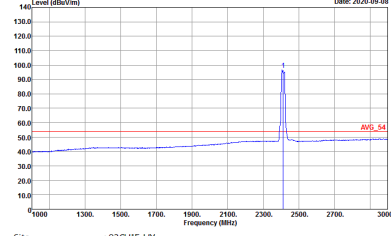

ANT	11n(20)_Tx_Ch01 - L	
1	Vertical	Fundamental
Peak	 <p>Level (dBm/1m) vs Frequency (MHz) plot for Vertical Peak. The y-axis ranges from 10.0 to 140.0 dBm/1m, and the x-axis ranges from 2310 to 2415 MHz. A red vertical line is at approximately 2395 MHz. The signal level is flat at ~60 dBm/1m until the red line, then rises to ~100 dBm/1m.</p> <p>Site : 03CH15-HY Condition : PEAK_BE_74 3m 9120D_15_1620 VERTICAL Detector : Peak Project : 072903-01 2.4G Setting : 13.5 5G Setting : 17.5</p>	 <p>Level (dBm/1m) vs Frequency (MHz) plot for Fundamental Peak. The y-axis ranges from 10.0 to 140.0 dBm/1m, and the x-axis ranges from 0 to 3000 MHz. A red vertical line is at approximately 2395 MHz. A sharp peak is visible at ~2395 MHz, reaching ~100 dBm/1m. A red label 'PEAK_74' is next to the peak.</p> <p>Site : 03CH15-HY Condition : PEAK_74 3m 9120D_15_1620 VERTICAL Detector : Peak Project : 072903-01 2.4G Setting : 13.5 5G Setting : 17.5</p>
Avg.	 <p>Level (dBm/1m) vs Frequency (MHz) plot for Vertical Avg. The y-axis ranges from 10.0 to 140.0 dBm/1m, and the x-axis ranges from 2310 to 2415 MHz. A red vertical line is at approximately 2395 MHz. The signal level is flat at ~60 dBm/1m until the red line, then rises to ~100 dBm/1m.</p> <p>Site : 03CH15-HY Condition : AVG_BE_54 3m 9120D_15_1620 VERTICAL Detector : Peak Project : 072903-01 2.4G Setting : 13.5 5G Setting : 17.5</p>	 <p>Level (dBm/1m) vs Frequency (MHz) plot for Fundamental Avg. The y-axis ranges from 10.0 to 140.0 dBm/1m, and the x-axis ranges from 0 to 3000 MHz. A red vertical line is at approximately 2395 MHz. A sharp peak is visible at ~2395 MHz, reaching ~100 dBm/1m. A red label 'AVG_54' is next to the peak.</p> <p>Site : 03CH15-HY Condition : AVG_54 3m 9120D_15_1620 VERTICAL Detector : Peak Project : 072903-01 2.4G Setting : 13.5 5G Setting : 17.5</p>



11n(20)_Tx_Ch01+11ac(80)_Tx_Ch42 (Band Edge @ 3m)

ANT	11ac(80)_Tx_Ch42 - L	
1+2	Horizontal	Fundamental
<p style="text-align: center;">Peak</p>	<p>Date: 2020-09-08</p> <p>Site : 03CH15-HY Condition : PEAK_BE_74 3m 9120D_15_1620 HORIZONTAL : RBW:1000.000KHz VBW:3000.000KHz SWT:Auto Detector : Peak Project : 072903-01 Z46 Setting : 13.5 5s Setting : 17.5</p>	<p>Date: 2020-09-08</p> <p>Site : 03CH15-HY Condition : PEAK(UNIT) 3m 9120D_15_1620 HORIZONTAL : RBW:1000.000KHz VBW:3000.000KHz SWT:Auto Detector : Peak Project : 072903-01 Z46 Setting : 13.5 5s Setting : 17.5</p>
<p style="text-align: center;">Avg.</p>	<p>Date: 2020-09-08</p> <p>Site : 03CH15-HY Condition : AVG_BE_54 3m 9120D_15_1620 HORIZONTAL : RBW:1000.000KHz VBW:3000.000KHz SWT:Auto Detector : Peak Project : 072903-01 Z46 Setting : 13.5 5s Setting : 17.5</p>	<p style="text-align: center;">Left blank</p>

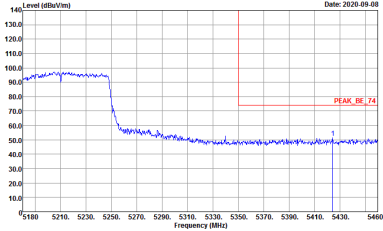
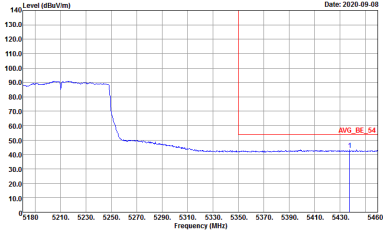

ANT	11ac(80)_Tx_Ch42 - R	
1+2	Horizontal	Fundamental
<p>Peak</p>	 <p>Site : 03CH15-HY Condition : PEAK_BE_74 3m 91200_15_1620 HORIZONTAL Detector : Peak Project : 072903-01 2.4G Setting : 13.5 5G Setting : 17.5</p>	<p>Left blank</p>
<p>Avg.</p>	 <p>Site : 03CH15-HY Condition : AVG_BE_54 3m 91200_15_1620 HORIZONTAL Detector : Peak Project : 072903-01 2.4G Setting : 13.5 5G Setting : 17.5</p>	<p>Left blank</p>

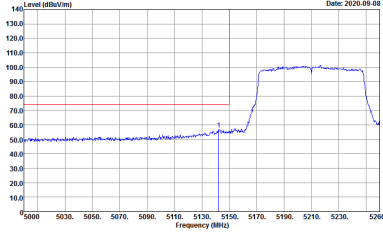
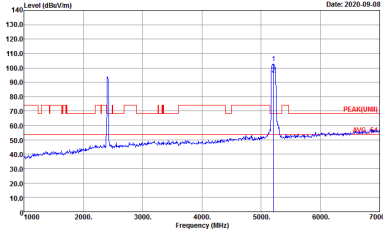
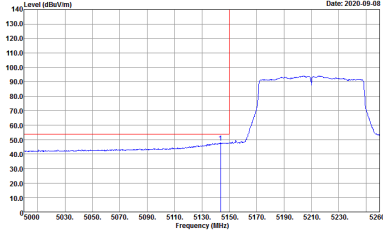

ANT	11ac(80)_Tx_Ch42 - L	
1+2	Vertical	Fundamental
<p style="text-align: center;">Peak</p>	 <p>Level (dBm/1m) vs Frequency (MHz) plot showing a peak at approximately 5170 MHz. The y-axis ranges from 10.0 to 140.0 dBm/1m, and the x-axis ranges from 5000 to 5260 MHz. A red line indicates the peak level at approximately 100 dBm/1m.</p> <p>Site : 03CH15-HY Condition : PEAK_BE_74 3m 91200_15_1620 VERTICAL RBW:1000.000KHz VBW:3000.000KHz SWT:Auto Detector : Peak Project : 072903-01 Z46 Setting : 13.5 5G Setting : 17.5</p>	 <p>Level (dBm/1m) vs Frequency (MHz) plot showing a peak at approximately 5170 MHz. The y-axis ranges from 10.0 to 140.0 dBm/1m, and the x-axis ranges from 1000 to 7000 MHz. A red line indicates the peak level at approximately 100 dBm/1m.</p> <p>Site : 03CH15-HY Condition : PEAK(UNIT) 3m 91200_15_1620 VERTICAL RBW:1000.000KHz VBW:3000.000KHz SWT:Auto Detector : Peak Project : 072903-01 Z46 Setting : 13.5 5G Setting : 17.5</p>
<p style="text-align: center;">Avg.</p>	 <p>Level (dBm/1m) vs Frequency (MHz) plot showing an average level at approximately 5170 MHz. The y-axis ranges from 10.0 to 140.0 dBm/1m, and the x-axis ranges from 5000 to 5260 MHz. A red line indicates the average level at approximately 100 dBm/1m.</p> <p>Site : 03CH15-HY Condition : AVG_BE_54 3m 91200_15_1620 VERTICAL RBW:1000.000KHz VBW:3000.000KHz SWT:Auto Detector : Peak Project : 072903-01 Z46 Setting : 13.5 5G Setting : 17.5</p>	<p style="text-align: center;">Left blank</p>

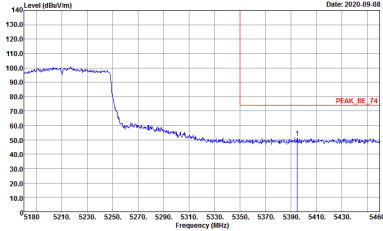
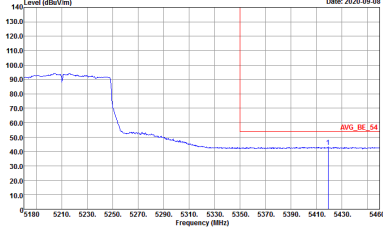

ANT	11ac(80)_Tx_Ch42 - R	
1+2	Vertical	Fundamental
<p style="text-align: center;">Peak</p>	 <p>Site : 03CH15-HY Condition : PEAK_BE_74 3m 91200_15_1620 VERTICAL Detector : Peak Project : 072903-01 Z46 Setting : 13.5 5G Setting : 17.5</p>	<p style="text-align: center;">Left blank</p>
<p style="text-align: center;">Avg.</p>	 <p>Site : 03CH15-HY Condition : AVG_BE_54 3m 91200_15_1620 VERTICAL Detector : Peak Project : 072903-01 Z46 Setting : 13.5 5G Setting : 17.5</p>	<p style="text-align: center;">Left blank</p>

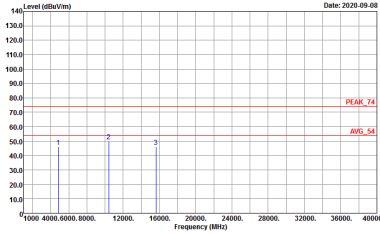
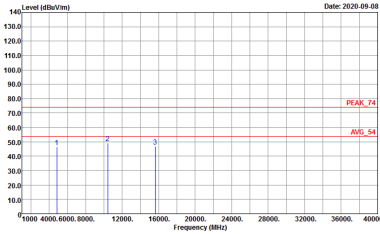

11n(20)_Tx_Ch01+11ac(80)_Tx_Ch42 (Harmonic @ 3m)

ANT	11n(20)_Tx_Ch01+11ac(80)_Tx_Ch42	
Simultaneously	Horizontal	Vertical
<p style="text-align: center;">Peak Avg.</p>	 <p>Site : 03CH15-HY Condition : PEAK_74 3m 9120D_15_1620 HORIZONTAL Detector : Peak Project : 072903-01 2.4G Setting : 13.5 5G Setting : 17.5</p>	 <p>Site : 03CH15-HY Condition : PEAK_74 3m 9120D_15_1620 VERTICAL Detector : Peak Project : 072903-01 2.4G Setting : 13.5 5G Setting : 17.5</p>



Emission below 1GHz

11n(20)_Tx_Ch01+11ac(80)_Tx_Ch42 (LF @ 3m)

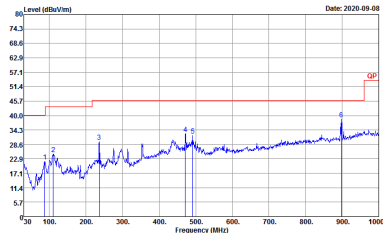
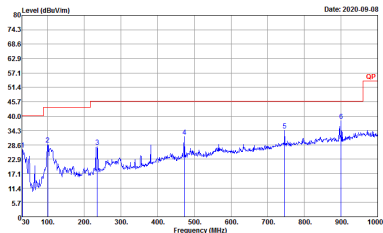
ANT	11n(20)_Tx_Ch01+11ac(80)_Tx_Ch42	
Simultaneously	Horizontal	Vertical
<p>Peak</p> <p>Avg.</p>	 <p>Site : 03CH15-11Y Condition : QP 3m B1LOG_15_41912 HORIZONTAL Detector : Peak Project : 072903-01 : 11g(n20)_Tx_Ch01+11ac(80)_Tx_Ch42</p>	 <p>Site : 03CH15-11Y Condition : QP 3m B1LOG_15_41912 VERTICAL Detector : Peak Project : 072903-01 : 11g(n20)_Tx_Ch01+11ac(80)_Tx_Ch42</p>



Appendix C. Duty Cycle Plots

Antenna	Band	Duty Cycle(%)	T(us)	1/T(kHz)	VBW Setting	Duty Factor(dB)
1	2.4GHz 802.11n HT20	97.97	1935	0.52	1kHz	0.09
1+2	5GHz 802.11ac VHT80 for Ant 1	94.82	732	1.37	3kHz	0.23
1+2	5GHz 802.11ac VHT80 for Ant 2	95.34	736	1.36	3kHz	0.21

<Ant. 1>

802.11n HT20

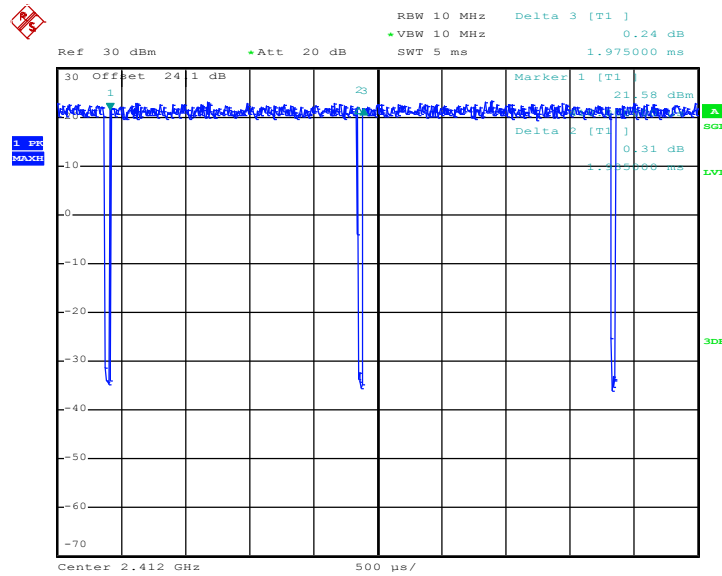

Date: 14.AUG.2020 18:14:17



MIMO <Ant. 1>

802.11ac VHT80

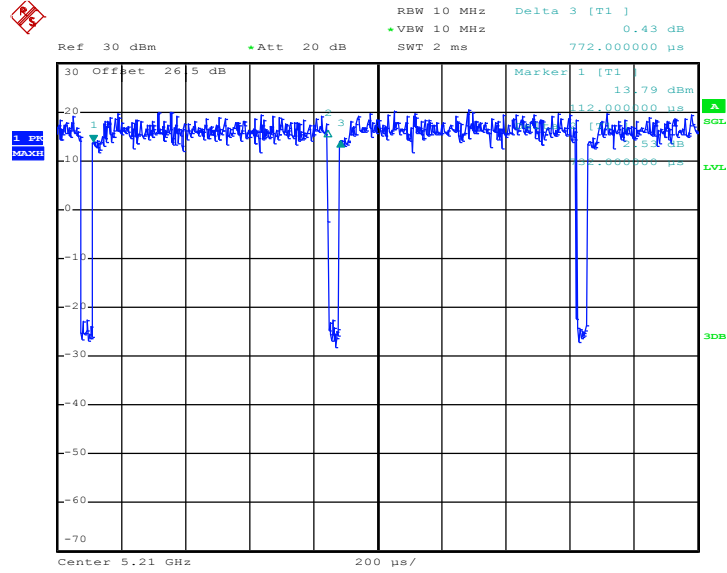

Date: 14.AUG.2020 13:17:01

MIMO <Ant. 2>

802.11ac VHT80

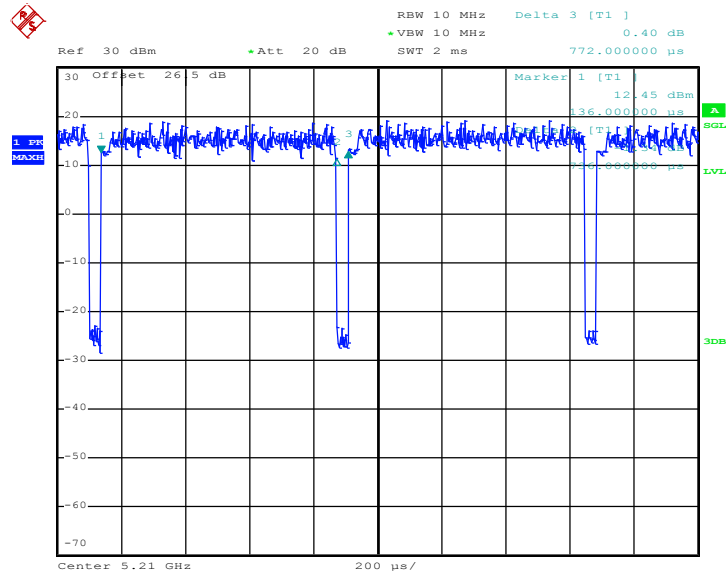

Date: 14.AUG.2020 13:18:26