



FCC RF Test Report

APPLICANT : Zebra Technologies Corporation
EQUIPMENT : Enterprise Tablet
BRAND NAME : Zebra
MODEL NAME : ET55BT
FCC ID : UZ7ET55BT
STANDARD : FCC Part 15 Subpart E §15.407
CLASSIFICATION : (NII) Unlicensed National Information Infrastructure

The product was received on May 03, 2016 and testing was completed on Jul. 21, 2016. We, SPORTON INTERNATIONAL INC., would like to declare that the tested sample has been evaluated in accordance with the test procedures and has been in compliance with the applicable technical standards.

The test results in this report apply exclusively to the tested model / sample. Without written approval of SPORTON INTERNATIONAL INC., the test report shall not be reproduced except in full.

Reviewed by: Joseph Lin / Supervisor

Approved by: Jones Tsai / Manager



SPORTON INTERNATIONAL INC.

No. 52, Hwa Ya 1st Rd., Hwa Ya Technology Park, Kwei-Shan District, Tao Yuan City, Taiwan, R.O.C.

SPORTON INTERNATIONAL INC.

TEL : 886-3-327-3456

FAX : 886-3-328-4978

FCC ID : UZ7ET55BT

Page Number : 1 of 48

Report Issued Date : Aug. 11, 2016

Report Version : Rev. 02

Report Template No.: BU5-FR15EWLAC MA Version 1.4



TABLE OF CONTENTS

REVISION HISTORY..... 3

SUMMARY OF TEST RESULT 4

1 GENERAL DESCRIPTION 5

 1.1 Applicant 5

 1.2 Manufacturer 5

 1.3 Product Feature of Equipment Under Test..... 5

 1.4 Product Specification of Equipment Under Test..... 6

 1.5 Modification of EUT 8

 1.6 Testing Location 9

 1.7 Applicable Standards..... 9

2 TEST CONFIGURATION OF EQUIPMENT UNDER TEST 10

 2.1 Carrier Frequency and Channel 10

 2.2 Pre-Scanned RF Power 11

 2.3 Test Mode 15

 2.4 Connection Diagram of Test System 18

 2.5 Support Unit used in test configuration and system 19

 2.6 EUT Operation Test Setup 20

 2.7 Measurement Results Explanation Example..... 20

3 TEST RESULT 21

 3.1 26dB & 99% Occupied Bandwidth Measurement 21

 3.2 Maximum Conducted Output Power Measurement 24

 3.3 Power Spectral Density Measurement 29

 3.4 Unwanted Emissions Measurement 33

 3.5 AC Conducted Emission Measurement..... 38

 3.6 Frequency Stability Measurement 42

 3.7 Automatically Discontinue Transmission 43

 3.8 Antenna Requirements 44

4 LIST OF MEASURING EQUIPMENT 47

5 UNCERTAINTY OF EVALUATION 48

APPENDIX A. CONDUCTED TEST RESULTS

APPENDIX B. RADIATED SPURIOUS EMISSION

APPENDIX C. RADIATED SPURIOUS EMISSION PLOTS

APPENDIX D. DUTY CYCLE PLOTS

APPENDIX E. SETUP PHOTOGRAPHS



REVISION HISTORY

REPORT NO.	VERSION	DESCRIPTION	ISSUED DATE
FR660115E	Rev. 01	Initial issue of report	Aug. 04, 2016
FR660115E	Rev. 02	Revising channel frequency range in the section 1.4	Aug. 11, 2016



SUMMARY OF TEST RESULT

Report Section	FCC Rule	Description	Limit	Result	Remark
3.1	2.1049 15.403(i)	26dB & 99% Bandwidth	-	Pass	-
3.2	15.407(a)	Maximum Conducted Output Power	≤ 24 dBm (depend on band)	Pass	-
3.3	15.407(a)	Power Spectral Density	≤ 11 dBm (depend on band)	Pass	-
3.4	15.407(b)	Unwanted Emissions	≤ -17, -27 dBm (depend on band) & 15.209(a)	Pass	Under limit 1.21 dB at 5116.220 MHz
3.5	15.207	AC Conducted Emission	15.207(a)	Pass	Under limit 16.70 dB at 0.206 MHz
3.6	15.407(g)	Frequency Stability	Within Operation Band	Pass	-
3.7	15.407(c)	Automatically Discontinue Transmission	Discontinue Transmission	Pass	-
3.8	15.203 & 15.407(a)	Antenna Requirement	N/A	Pass	-



1 General Description

1.1 Applicant

Zebra Technologies Corporation
1 Zebra Plaza, Holtsville, NY 11742

1.2 Manufacturer

Zebra Technologies Corporation
1 Zebra Plaza, Holtsville, NY 11742

1.3 Product Feature of Equipment Under Test

Product Feature	
Equipment	Enterprise Tablet
Brand Name	Zebra
Model Name	ET55BT
FCC ID	UZ7ET55BT
EUT supports Radios application	CDMA/EV-DO/GSM/EGPRS/WCDMA/HSPA/LTE/NFC WLAN 11a/b/g/n HT20/HT40 WLAN 11ac VHT20/VHT40/VHT80 Bluetooth v4.0 EDR/LE
HW Version	DV1
SW Version	5.1.1
FW Version	7.35.205.4
MFD	31-Mar-16
EUT Stage	Identical Prototype

Remark: The above EUT's information was declared by manufacturer. Please refer to the specifications or user's manual for more detailed description.



1.4 Product Specification of Equipment Under Test

Standards-related Product Specification	
Tx/Rx Channel Frequency Range	5180 MHz ~ 5240 MHz 5260 MHz ~ 5320 MHz 5500 MHz ~ 5580 MHz and 5660 MHz ~ 5720 MHz
Maximum Output Power <CDD Modes>	<p><5180 MHz ~ 5240 MHz> SISO <Ant. 1> 802.11a : 11.33 dBm / 0.0136 W 802.11n HT20 : 11.37 dBm / 0.0137 W 802.11n HT40 : 11.38 dBm / 0.0137 W 802.11ac VHT20: 11.36 dBm / 0.0137 W 802.11ac VHT40: 11.47 dBm / 0.0140 W 802.11ac VHT80: 10.89 dBm / 0.0123 W SISO <Ant. 2> 802.11a : 11.32 dBm / 0.0136 W 802.11n HT20 : 11.38 dBm / 0.0137 W 802.11n HT40 : 11.43 dBm / 0.0139 W 802.11ac VHT20: 11.39 dBm / 0.0138 W 802.11ac VHT40: 11.46 dBm / 0.0140 W 802.11ac VHT80: 10.90 dBm / 0.0123 W MIMO <Ant. 1 + 2> 802.11a : 14.39 dBm / 0.0275 W 802.11n HT20 : 14.39 dBm / 0.0275 W 802.11n HT40 : 14.48 dBm / 0.0281 W 802.11ac VHT20: 14.44 dBm / 0.0278 W 802.11ac VHT40: 14.49 dBm / 0.0281 W 802.11ac VHT80: 12.56 dBm / 0.0180 W</p> <p><5260 MHz ~ 5320 MHz> SISO <Ant. 1> 802.11a : 11.38 dBm / 0.0137 W 802.11n HT20 : 11.32 dBm / 0.0136 W 802.11n HT40 : 11.34 dBm / 0.0136 W 802.11ac VHT20: 11.37 dBm / 0.0137 W 802.11ac VHT40: 11.35 dBm / 0.0136 W 802.11ac VHT80: 10.78 dBm / 0.0120 W SISO <Ant. 2> 802.11a : 11.44 dBm / 0.0139 W 802.11n HT20 : 11.37 dBm / 0.0137 W 802.11n HT40 : 11.31 dBm / 0.0135 W 802.11ac VHT20: 11.39 dBm / 0.0138 W 802.11ac VHT40: 11.41 dBm / 0.0138 W 802.11ac VHT80: 10.79 dBm / 0.0120 W MIMO <Ant. 1 + 2> 802.11a : 14.49 dBm / 0.0281 W 802.11n HT20 : 14.41 dBm / 0.0276 W 802.11n HT40 : 14.44 dBm / 0.0278 W 802.11ac VHT20: 14.43 dBm / 0.0277 W 802.11ac VHT40: 14.45 dBm / 0.0279 W 802.11ac VHT80: 13.83 dBm / 0.0242 W</p>



Product Specification subjective to this standard	
Maximum Output Power <CDD Modes>	<p>5500 MHz ~ 5580 MHz and 5660 MHz ~ 5720 MHz SISO <Ant. 1> 802.11a : 10.48 dBm / 0.0112 W 802.11n HT20 : 10.42 dBm / 0.0110 W 802.11n HT40 : 10.35 dBm / 0.0108 W 802.11ac VHT20: 10.44 dBm / 0.0111 W 802.11ac VHT40: 10.48 dBm / 0.0112 W 802.11ac VHT80: 9.89 dBm / 0.0097 W SISO <Ant. 2> 802.11a : 12.76 dBm / 0.0189 W 802.11n HT20 : 12.77 dBm / 0.0189 W 802.11n HT40 : 12.82 dBm / 0.0191 W 802.11ac VHT20: 12.82 dBm / 0.0191 W 802.11ac VHT40: 12.89 dBm / 0.0195 W 802.11ac VHT80: 12.30 dBm / 0.0170 W MIMO <Ant. 1 + 2> 802.11a : 13.48 dBm / 0.0223 W 802.11n HT20 : 13.47 dBm / 0.0222 W 802.11n HT40 : 13.43 dBm / 0.0220 W 802.11ac VHT20: 13.48 dBm / 0.0223 W 802.11ac VHT40: 13.46 dBm / 0.0222 W 802.11ac VHT80: 12.82 dBm / 0.0191 W</p>
Maximum Output Power <TXBF Modes>	<p><5180 MHz ~ 5240 MHz> MIMO <Ant. Port 1 + 2> 802.11a : 14.47 dBm / 0.0280 W 802.11n HT20 : 14.31 dBm / 0.0270 W 802.11n HT40 : 14.21 dBm / 0.0264 W 802.11ac VHT20: 14.48 dBm / 0.0281 W 802.11ac VHT40: 14.47 dBm / 0.0280 W 802.11ac VHT80: 14.37 dBm / 0.0274 W <5260 MHz ~ 5320 MHz> MIMO <Ant. Port 1 + 2> 802.11a : 14.41 dBm / 0.0276 W 802.11n HT20 : 14.36 dBm / 0.0273 W 802.11n HT40 : 14.36 dBm / 0.0273 W 802.11ac VHT20: 14.46 dBm / 0.0279 W 802.11ac VHT40: 14.46 dBm / 0.0279 W 802.11ac VHT80: 14.45 dBm / 0.0279 W 5500 MHz ~ 5580 MHz and 5660 MHz ~ 5720 MHz MIMO <Ant. Port 1 + 2> 802.11a : 13.47 dBm / 0.0222 W 802.11n HT20 : 13.44 dBm / 0.0221 W 802.11n HT40 : 13.44 dBm / 0.0221 W 802.11ac VHT20: 13.48 dBm / 0.0223 W 802.11ac VHT40: 13.45 dBm / 0.0221 W 802.11ac VHT80: 13.28 dBm / 0.0213 W</p>



Product Specification subjective to this standard										
99% Occupied Bandwidth <CDD Modes>	802.11a : 18.45 MHz 802.11n HT20 : 19.15 MHz 802.11n HT40 : 36.80 MHz 802.11ac VHT20 : 19.20 MHz 802.11ac VHT40 : 36.80 MHz 802.11ac VHT80 : 75.96 MHz									
99% Occupied Bandwidth <TXBF Modes>	802.11a : 19.05 MHz 802.11n HT20 : 19.00 MHz 802.11n HT40 : 36.90 MHz 802.11ac VHT20 : 19.10 MHz 802.11ac VHT40 : 36.90 MHz 802.11ac VHT80 : 76.44 MHz									
Type of Modulation	802.11a/n : OFDM (BPSK / QPSK / 16QAM / 64QAM) 802.11ac : OFDM (BPSK / QPSK / 16QAM / 64QAM / 256QAM)									
Antenna Type	Main Antenna : Ceramic Chip Antenna Aux. Antenna : Ceramic Chip Antenna									
Antenna Gain	<5180 MHz ~ 5240 MHz> Main Antenna : 1.40 dBi Aux. Antenna : 1.00 dBi <5250 MHz ~ 5350 MHz> Main Antenna : 1.40 dBi Aux. Antenna : 1.00 dBi 5500 MHz ~ 5580 MHz and 5660 MHz ~ 5720 MHz Main Antenna : 1.60 dBi Aux. Antenna : 0.90 dBi									
Antenna Function Description	<table border="1"> <thead> <tr> <th></th> <th>Ant. 1</th> <th>Ant. 2</th> </tr> </thead> <tbody> <tr> <td>802.11 a/n/ac SISO</td> <td>V</td> <td>V</td> </tr> <tr> <td>802.11 a/n/ac MIMO</td> <td>V</td> <td>V</td> </tr> </tbody> </table>		Ant. 1	Ant. 2	802.11 a/n/ac SISO	V	V	802.11 a/n/ac MIMO	V	V
	Ant. 1	Ant. 2								
802.11 a/n/ac SISO	V	V								
802.11 a/n/ac MIMO	V	V								

1.5 Modification of EUT

No modifications are made to the EUT during all test items.



1.6 Testing Location

Sporton Lab is accredited to ISO 17025 by Taiwan Accreditation Foundation (TAF code : 1190) and the FCC designation No. TW1022 under the FCC 2.948(e) by Mutual Recognition Agreement (MRA) in FCC Test.

Test Site	SPORTON INTERNATIONAL INC.		
Test Site Location	No. 52, Hwa Ya 1 st Rd., Hwa Ya Technology Park, Kwei-Shan District, Tao Yuan City, Taiwan, R.O.C. TEL: +886-3-327-3456 FAX: +886-3-328-4978		
Test Site No.	Sporton Site No.		
	TH05-HY	CO05-HY	03CH07-HY

Note: The test site complies with ANSI C63.4 2014 requirement.

1.7 Applicable Standards

According to the specifications of the manufacturer, the EUT must comply with the requirements of the following standards:

- ♦ FCC Part 15 Subpart E
- ♦ FCC KDB 789033 D02 General UNII Test Procedures New Rules v01r02
- ♦ FCC KDB 662911 D01 Multiple Transmitter Output v02r01.
- ♦ FCC KDB 644545 D03 Guidance for IEEE 802 11ac New Rules v01
- ♦ ANSI C63.10-2013

Remark:

1. All test items were verified and recorded according to the standards and without any deviation during the test.
2. This EUT has also been tested and complied with the requirements of FCC Part 15, Subpart B, recorded in a separate test report.



2 Test Configuration of Equipment Under Test

The EUT has been associated with peripherals and configuration operated in a manner tended to maximize its emission characteristics in a typical application. Frequency range investigated: conducted emission (150 kHz to 30 MHz) and radiated emission (9 kHz to the 10th harmonic of the highest fundamental frequency or to 40 GHz, whichever is lower). For radiated measurement, pre-scanned in three orthogonal panels, X, Y, Z. The worst cases (Y plane for Ant. 1 in CDD Modes; X plane for Ant. 1+2 in CDD Modes and TXBF Modes) were recorded in this report.

2.1 Carrier Frequency and Channel

Frequency Band	Channel	Freq. (MHz)	Channel	Freq. (MHz)
5150-5250 MHz Band 1 (U-NII-1)	36	5180	44	5220
	38	5190	46	5230
	40	5200	48	5240
	42	5210		

Frequency Band	Channel	Freq. (MHz)	Channel	Freq. (MHz)
5250-5350 MHz Band 2 (U-NII-2A)	52	5260	60	5300
	54	5270	62	5310
	56	5280	64	5320
	58	5290		

Frequency Band	Channel	Freq. (MHz)	Channel	Freq. (MHz)
5470-5600 MHz and 5650-5725 MHz Band 3 (U-NII-2C)	100	5500	112	5560
	102	5510	116	5580
	104	5520	132	5660
	106	5530	134	5670
	108	5540	136	5680
	110	5550	140	5700

Frequency Band	Channel	Freq. (MHz)	Channel	Freq. (MHz)
Straddle Channel	144	5720	142	5710
	138	5690		

Note: The above Frequency and Channel in boldface were 802.11n HT40.



2.2 Pre-Scanned RF Power

Preliminary tests were performed in different data rate and data rate associated with the highest power were chosen for full test in the following tables.

<CDD Modes>

SISO <Ant. 1>

5GHz 802.11a mode								
Data Rate (MHz)	6M bps	9M bps	12M bps	18M bps	24M bps	36M bps	48M bps	54M bps
Average Power (dBm)	11.38	11.35	11.37	11.32	9.56	9.80	9.76	9.79

5GHz 802.11n HT20 mode								
Data Rate (MHz)	MCS0	MCS1	MCS2	MCS3	MCS4	MCS5	MCS6	MCS7
Average Power (dBm)	11.37	11.34	11.35	9.87	9.81	10.10	9.97	9.11

5GHz 802.11n HT40 mode								
Data Rate (MHz)	MCS0	MCS1	MCS2	MCS3	MCS4	MCS5	MCS6	MCS7
Average Power (dBm)	11.38	11.35	11.37	9.82	10.06	9.94	10.03	8.94

5GHz 802.11ac VHT20 mode									
Data Rate (MHz)	MCS 0	MCS 1	MCS 2	MCS 3	MCS 4	MCS 5	MCS 6	MCS 7	MCS 8
Average Power (dBm)	11.37	11.35	11.36	9.91	9.97	10.09	10.01	9.17	8.82

5GHz 802.11ac VHT40 mode										
Data Rate (MHz)	MCS 0	MCS 1	MCS 2	MCS 3	MCS 4	MCS 5	MCS 6	MCS 7	MCS 8	MCS 9
Average Power (dBm)	11.47	11.42	11.45	10.17	10.08	10.15	10.19	9.14	8.46	8.27

5GHz 802.11ac VHT80 mode										
Data Rate (MHz)	MCS 0	MCS 1	MCS 2	MCS 3	MCS 4	MCS 5	MCS 6	MCS 7	MCS 8	MCS 9
Average Power (dBm)	10.89	10.86	10.89	10.79	10.87	10.89	10.79	9.91	8.49	8.14



SISO <Ant. 2>

5GHz 802.11a mode								
Data Rate (MHz)	6M bps	9M bps	12M bps	18M bps	24M bps	36M bps	48M bps	54M bps
Average Power (dBm)	12.76	12.72	12.74	12.73	11.27	11.32	11.40	11.26

5GHz 802.11n HT20 mode								
Data Rate (MHz)	MCS0	MCS1	MCS2	MCS3	MCS4	MCS5	MCS6	MCS7
Average Power (dBm)	12.77	12.73	12.75	11.19	11.35	11.35	11.32	10.50

5GHz 802.11n HT40 mode								
Data Rate (MHz)	MCS0	MCS1	MCS2	MCS3	MCS4	MCS5	MCS6	MCS7
Average Power (dBm)	12.82	12.72	12.62	11.37	11.43	11.32	11.39	10.41

5GHz 802.11ac VHT20 mode									
Data Rate (MHz)	MCS 0	MCS 1	MCS 2	MCS 3	MCS 4	MCS 5	MCS 6	MCS 7	MCS 8
Average Power (dBm)	12.82	12.80	12.81	11.40	11.28	11.31	11.35	10.47	10.51

5GHz 802.11ac VHT40 mode										
Data Rate (MHz)	MCS 0	MCS 1	MCS 2	MCS 3	MCS 4	MCS 5	MCS 6	MCS 7	MCS 8	MCS 9
Average Power (dBm)	12.89	12.85	12.84	11.70	11.62	11.74	11.78	10.76	10.26	9.73

5GHz 802.11ac VHT80 mode										
Data Rate (MHz)	MCS 0	MCS 1	MCS 2	MCS 3	MCS 4	MCS 5	MCS 6	MCS 7	MCS 8	MCS 9
Average Power (dBm)	12.30	12.28	12.29	12.20	12.26	12.17	12.18	11.42	10.04	9.91



MIMO <Ant. 1+2>

5GHz 802.11a mode								
Data Rate (MHz)	6M bps	9M bps	12M bps	18M bps	24M bps	36M bps	48M bps	54M bps
Average Power (dBm)	14.49	14.45	14.46	14.44	12.70	12.75	13.00	12.81

5GHz 802.11n HT20 mode								
Data Rate (MHz)	MCS 0	MCS 1	MCS 2	MCS 3	MCS 4	MCS 5	MCS 6	MCS 7
Average Power (dBm)	14.41	14.39	14.40	12.97	12.95	12.90	12.87	11.90

5GHz 802.11n HT40 mode								
Data Rate (MHz)	MCS 0	MCS 1	MCS 2	MCS 3	MCS 4	MCS 5	MCS 6	MCS 7
Average Power (dBm)	14.48	14.41	14.38	13.04	12.97	13.07	13.06	12.08

5GHz 802.11ac VHT20 mode									
Data Rate (MHz)	MCS 0	MCS 1	MCS 2	MCS 3	MCS 4	MCS 5	MCS 6	MCS 7	MCS 8
Average Power (dBm)	14.44	14.42	14.43	12.85	12.96	12.97	12.97	11.93	12.12

5GHz 802.11ac VHT40 mode										
Data Rate (MHz)	MCS 0	MCS 1	MCS 2	MCS 3	MCS 4	MCS 5	MCS 6	MCS 7	MCS 8	MCS 9
Average Power (dBm)	14.49	14.47	14.48	12.97	13.04	13.01	13.19	12.02	11.42	10.86

5GHz 802.11ac VHT80 mode										
Data Rate (MHz)	MCS 0	MCS 1	MCS 2	MCS 3	MCS 4	MCS 5	MCS 6	MCS 7	MCS 8	MCS 9
Average Power (dBm)	12.82	12.76	12.78	12.74	12.68	12.69	12.60	11.69	9.97	9.95

Note: MIMO Ant. 1+2 is a calculated result from sum of the power MIMO Ant. 1 and MIMO Ant. 2.



<TXBF Modes>

MIMO <Ant. 1+2>

5GHz 802.11a mode								
Data Rate (MHz)	6M bps	9M bps	12M bps	18M bps	24M bps	36M bps	48M bps	54M bps
Average Power (dBm)	14.47	14.37	14.37	14.27	14.27	14.31	14.37	14.37

5GHz 802.11n HT20 mode								
Data Rate (MHz)	MCS 0	MCS 1	MCS 2	MCS 3	MCS 4	MCS 5	MCS 6	MCS 7
Average Power (dBm)	14.36	14.26	14.21	14.11	14.11	14.21	14.26	14.26

5GHz 802.11n HT40 mode								
Data Rate (MHz)	MCS 0	MCS 1	MCS 2	MCS 3	MCS 4	MCS 5	MCS 6	MCS 7
Average Power (dBm)	14.36	14.26	14.26	14.16	14.16	14.16	14.26	14.26

5GHz 802.11ac VHT20 mode									
Data Rate (MHz)	MCS 0	MCS 1	MCS 2	MCS 3	MCS 4	MCS 5	MCS 6	MCS 7	MCS 8
Average Power (dBm)	14.48	14.38	14.38	14.28	14.28	14.18	14.18	14.28	14.38

5GHz 802.11ac VHT40 mode										
Data Rate (MHz)	MCS 0	MCS 1	MCS 2	MCS 3	MCS 4	MCS 5	MCS 6	MCS 7	MCS 8	MCS 9
Average Power (dBm)	14.47	14.37	14.33	14.32	14.27	14.27	14.28	14.27	14.27	14.37

5GHz 802.11ac VHT80 mode										
Data Rate (MHz)	MCS 0	MCS 1	MCS 2	MCS 3	MCS 4	MCS 5	MCS 6	MCS 7	MCS 8	MCS 9
Average Power (dBm)	14.45	14.35	14.35	14.25	14.27	14.20	14.21	14.25	14.35	14.35

Note: MIMO Ant. 1+2 is a calculated result from sum of the power MIMO Ant. 1 and MIMO Ant. 2.



2.3 Test Mode

Final test mode of conducted test items and radiated spurious emissions are considering the modulation and worse data rates from the power table described in section 2.2.

Single Antenna

Modulation	Data Rate
802.11a	6 Mbps
802.11n HT20	MCS0
802.11n HT40	MCS0
802.11ac VHT20	MCS0
802.11ac VHT40	MCS0
802.11ac VHT80	MCS0

MIMO Antenna

Modulation	Data Rate
802.11a	6 Mbps
802.11n HT20	MCS0
802.11n HT40	MCS0
802.11ac VHT20	MCS0
802.11ac VHT40	MCS0
802.11ac VHT80	MCS0

Test Cases	
AC Conducted Emission	Mode 1 : Bluetooth Link + WLAN (5GHz) Link + USB Cable (Charging from Adapter) + Earphone + Battery



Ch. #		Band I : 5150-5250 MHz	Band II : 5250-5350 MHz	Band III : 5470-5600 MHz and 5650-5725MHz
		802.11a	802.11a	802.11a
L	Low	36	52	100
M	Middle	44	60	116
H	High	48	64	140
Straddle		-	-	144

Ch. #		Band I : 5150-5250 MHz	Band II : 5250-5350 MHz	Band III : 5470-5600 MHz and 5650-5725MHz
		802.11n HT20	802.11n HT20	802.11n HT20
L	Low	36	52	100
M	Middle	44	60	116
H	High	48	64	140
Straddle		-	-	144

Ch. #		Band I : 5150-5250 MHz	Band II : 5250-5350 MHz	Band III : 5470-5600 MHz and 5650-5725MHz
		802.11n HT40	802.11n HT40	802.11n HT40
L	Low	38	54	102
M	Middle	-	-	110
H	High	46	62	134
Straddle		-	-	142



Ch. #		Band I : 5150-5250 MHz	Band II : 5250-5350 MHz	Band III : 5470-5600 MHz and 5650-5725MHz
		802.11ac VHT20	802.11ac VHT20	802.11ac VHT20
L	Low	36	52	100
M	Middle	44	60	116
H	High	48	64	140
Straddle		-	-	144

Ch. #		Band I : 5150-5250 MHz	Band II : 5250-5350 MHz	Band III : 5470-5600 MHz and 5650-5725MHz
		802.11ac VHT40	802.11ac VHT40	802.11ac VHT40
L	Low	38	54	102
M	Middle	-	-	110
H	High	46	62	134
Straddle		-	-	142

Ch. #		Band I : 5150-5250 MHz	Band II : 5250-5350 MHz	Band III : 5470-5600 MHz and 5650-5725MHz
		802.11ac VHT80	802.11ac VHT80	802.11ac VHT80
L	Low	-	-	-
M	Middle	42	58	106
H	High	-	-	-
Straddle		-	-	138

2.4 Connection Diagram of Test System

<WLAN TX CDD Mode>

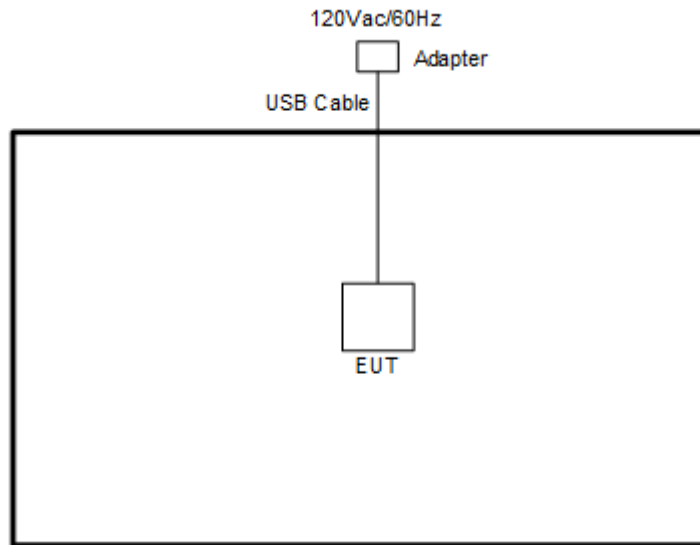

<WLAN Tx TXBF Mode>

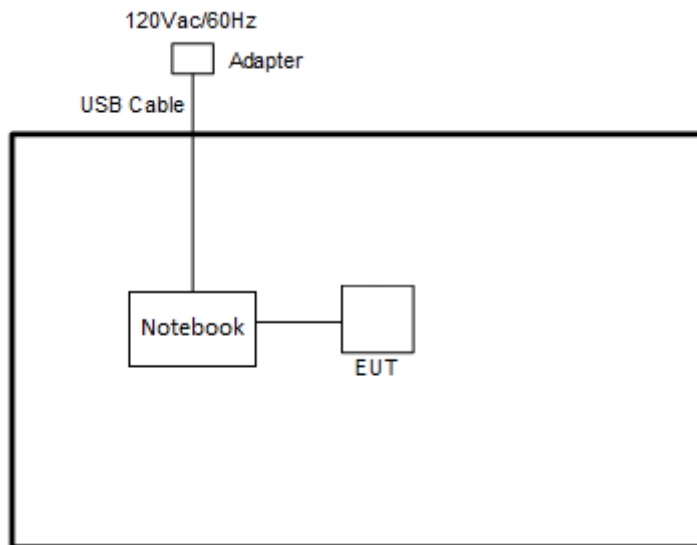

<AC Conducted Emission Mode>

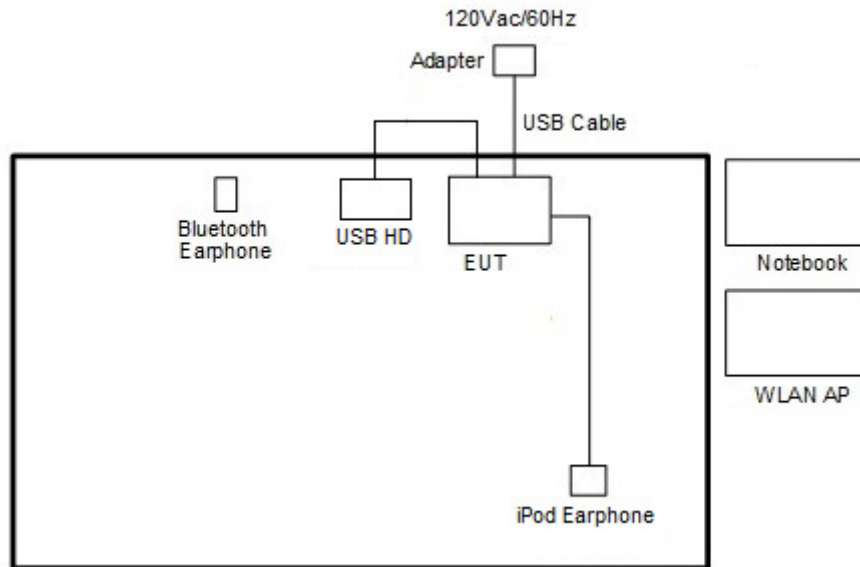

2.5 Support Unit used in test configuration and system

Item	Equipment	Trade Name	Model Name	FCC ID	Data Cable	Power Cord
1.	Bluetooth Earphone	Sony Ericsson	MW600	PY7DDA-2029	N/A	N/A
2.	WLAN AP	D-Link	DIR-865L	KA2IR865LA1	N/A	Unshielded, 1.8 m
3.	Notebook	DELL	Latitude E6320	FCC DoC/ Contains FCC ID: QDS-BRCM1054	N/A	AC I/P: Unshielded, 1.2 m DC O/P: Shielded, 1.8 m
4.	USB2.0 HD	WD	WDBAAR3200 ABK-PESN	FCC DoC	Unshielded, 0.5 m	N/A
5.	iPod Earphone	Apple	N/A	Verification	Unshielded, 1.0 m	N/A
6.	Adapter	Delta Electronics	ADP-10BWC	FCC DoC	N/A	N/A
7.	SD Card	SanDisk	MicroSD HC	FCC DoC	N/A	N/A



2.6 EUT Operation Test Setup

For Non-TXBF modes programmed RF utility is installed in EUT to provide channel selection, power level, data rate and the application type. RF Utility can send transmitting signal for all testing. The RF output power selection is for the setting of RF output power expected by the customer and is going to be fixed on the firmware of the final end product.

For WLAN MIMO TXBF modes, the EUT was tested under normal operation and link to another EUT with power, modulation modes and data rates controlled by engineer mode command lines. The iperf software tool was used to make EUT continuous transmitting signals.

2.7 Measurement Results Explanation Example

For all conducted test items:

The offset level is set in the spectrum analyzer to compensate the RF cable loss and attenuator factor between EUT conducted output port and spectrum analyzer. With the offset compensation, the spectrum analyzer reading level is exactly the EUT RF output level.

Example :

The spectrum analyzer offset is derived from RF cable loss and attenuator factor.

Offset = RF cable loss + attenuator factor.

Following shows an offset computation example with cable loss 4.2 dB and 10dB attenuator.

$$\begin{aligned} \text{Offset(dB)} &= \text{RF cable loss(dB)} + \text{attenuator factor(dB)}. \\ &= 4.2 + 10 = 14.2 \text{ (dB)} \end{aligned}$$

3 Test Result

3.1 26dB & 99% Occupied Bandwidth Measurement

3.1.1 Description of 26dB & 99% Occupied Bandwidth

This section is for reporting purpose only.

There is no restriction limits for bandwidth.

For Straddle Channel, U-NII procedures were applied for operations in the frequency band in accordance with FCC KDB 644545 D03.

3.1.2 Measuring Instruments

The measuring equipment is listed in the section 4 of this test report.

3.1.3 Test Procedures

1. The testing follows FCC KDB 789033 D02 General UNII Test Procedures New Rules v01r02. Section C) Emission bandwidth
2. Set RBW = approximately 1% of the emission bandwidth.
3. Set the VBW > RBW.
4. Detector = Peak.
5. Trace mode = max hold
6. Measure the maximum width of the emission that is 26 dB down from the peak of the emission. Compare this with the RBW setting of the analyzer. Readjust RBW and repeat measurement as needed until the RBW/EBW ratio is approximately 1%.
7. For 99% Bandwidth Measurement, the spectrum analyzer's resolution bandwidth (RBW) is set 1MHz and set the Video bandwidth (VBW) $\geq 3 * RBW$.
8. Measure and record the results in the test report.

3.1.4 Test Setup

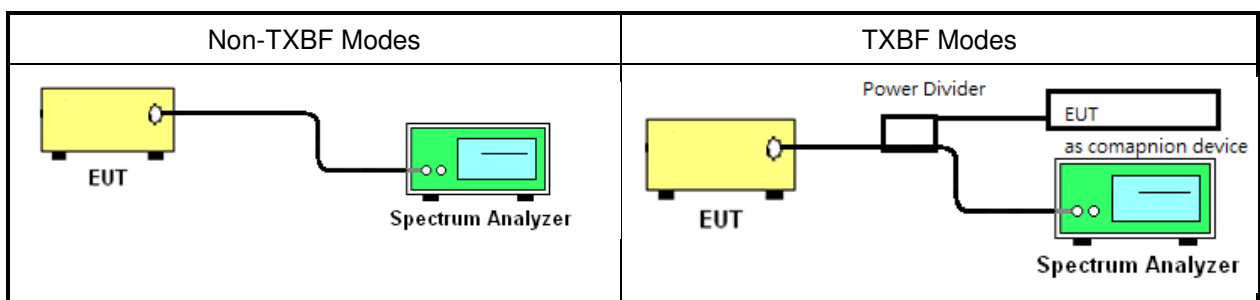



3.1.5 Test Result of 26dB & 99% Occupied Bandwidth

Please refer to Appendix A.

<CDD Modes>

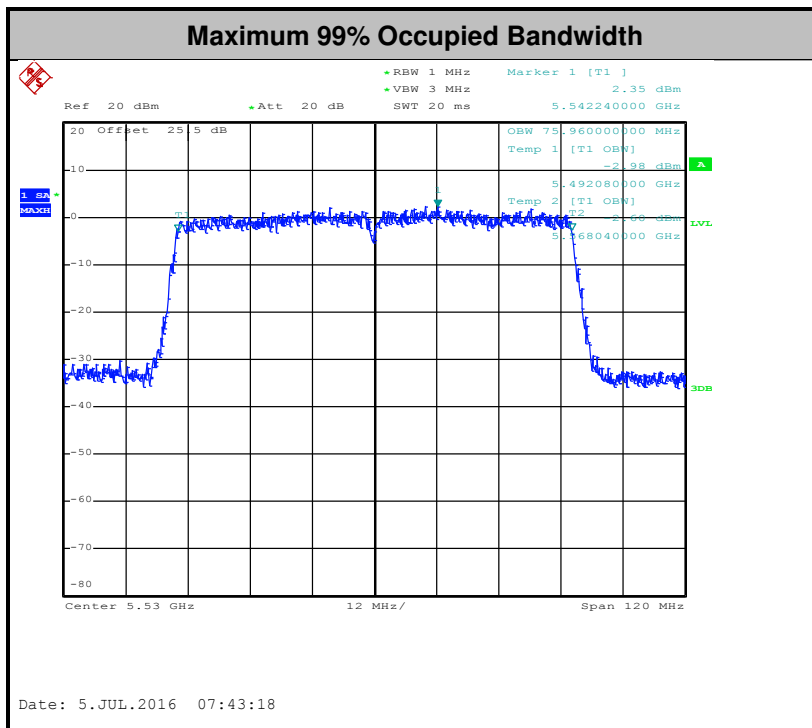
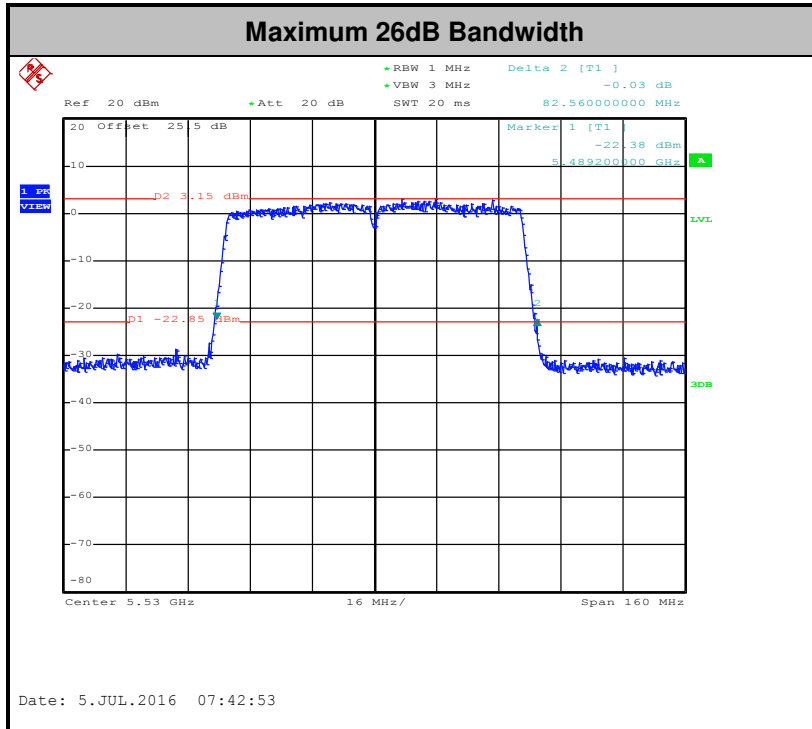

Note: The occupied channel bandwidth is maintained within the band of operation for all of the modulations.



<TXBF Modes>

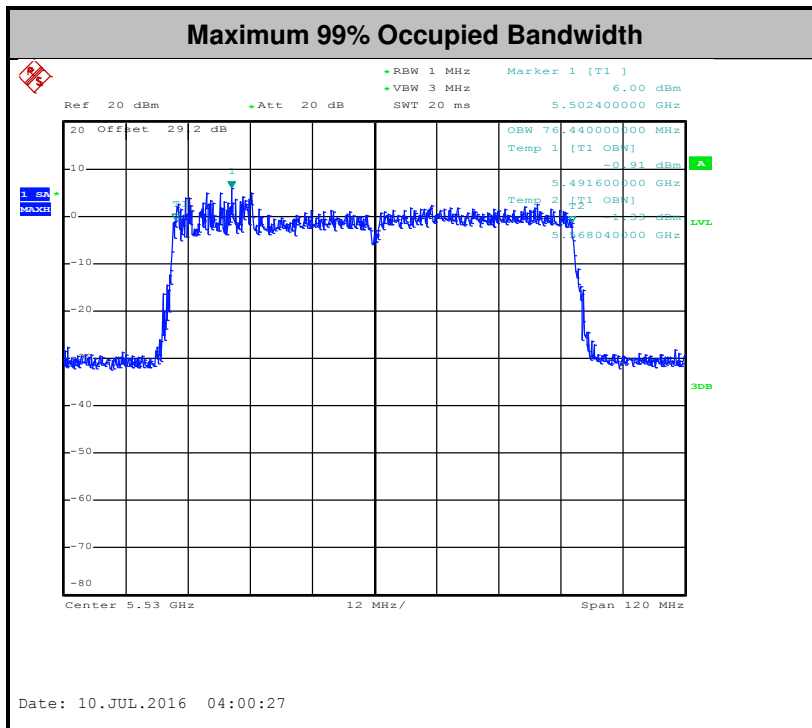
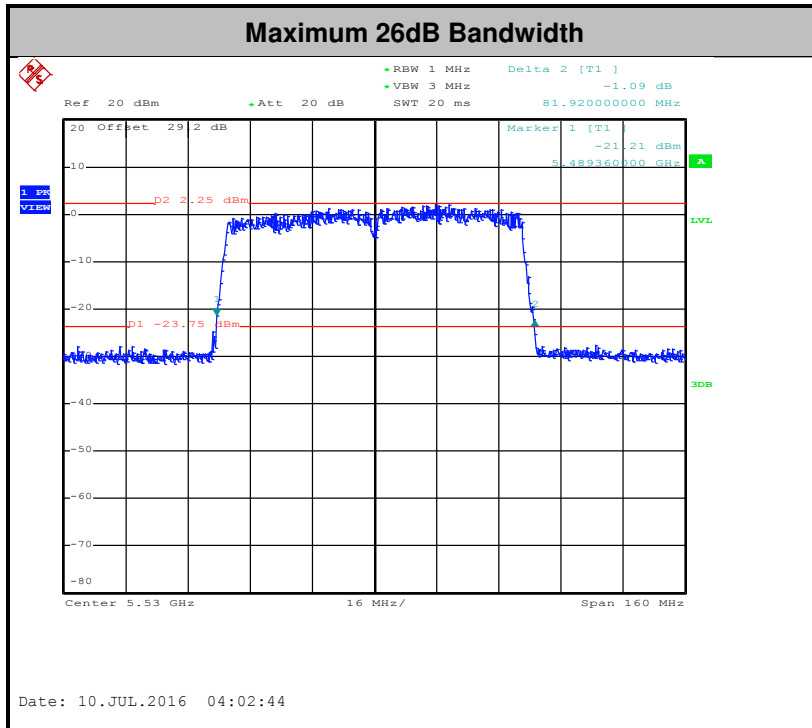

Note: The occupied channel bandwidth is maintained within the band of operation for all of the modulations.



3.2 Maximum Conducted Output Power Measurement

3.2.1 Limit of Maximum Conducted Output Power

For mobile and portable client devices in the 5.15–5.25 GHz band, the maximum conducted output power over the frequency band of operation shall not exceed 250 mW.

For the 5.25–5.35 GHz and 5.47–5.725 GHz bands, the maximum conducted output power over the frequency bands of operation shall not exceed the lesser of 250 mW or $11 \text{ dBm} + 10 \log B$, where B is the 26 dB emission bandwidth in megahertz.

For Straddle Channel, U-NII procedures and limits were applied for operations in the frequency band in accordance with FCC KDB 644545 D03.

If transmitting antennas of directional gain greater than 6 dBi are used, the peak output power shall be reduced by the amount in dB that the directional gain of the antenna exceeds 6 dBi.

Note that U-NII-2 band, devices with a maximum e.i.r.p. greater than 500 mW shall implement TPC in order to have the capability to operate at least 6 dB below the maximum permitted e.i.r.p. of 1 W.

3.2.2 Measuring Instruments

The measuring equipment is listed in the section 4 of this test report.



3.2.3 Test Procedures

CDD modes

The testing follows Method PM of FCC KDB 789033 D02 General UNII Test Procedures New Rules v01r02 for CDD modes.

Method PM (Measurement using an RF average power meter):

1. Measurement is performed using a wideband RF power meter.
2. The EUT is configured to transmit continuously with a consistent duty cycle at its maximum power control level.
3. Measure the average power of the transmitter, and the average power is corrected with duty factor, $10 \log(1/x)$, where x is the duty cycle.

TXBF modes

The testing follows Method PM-G of FCC KDB 789033 D02 General UNII Test Procedures New Rules v01r02 for TXBF modes.

Method PM-G (Measurement using a gated RF average power meter):

1. Measurement is performed using a wideband RF power meter.
2. The EUT is configured to transmit at its maximum power control level.
3. Measure the average power of the transmitter
4. Since the measurement is made only during the ON time of the transmitter, no duty cycle correction factor is required.

For straddle channel, the testing follows Method SA-3 (RMS detection with max hold) of FCC KDB 789033 D02 General UNII Test Procedures New Rules v01r02.

Compute power by integrating the spectrum across the 99% occupied bandwidth of the signal using the instrument's band power measurement function.

3.2.4 Test Setup

For normal channel:

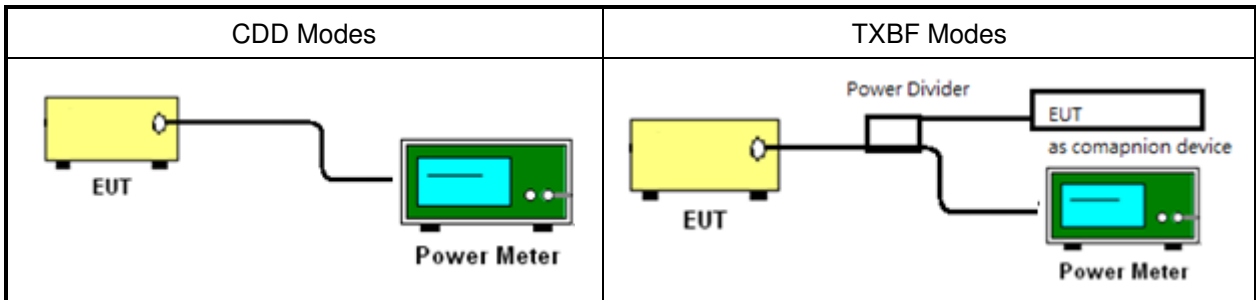

For straddle channel:

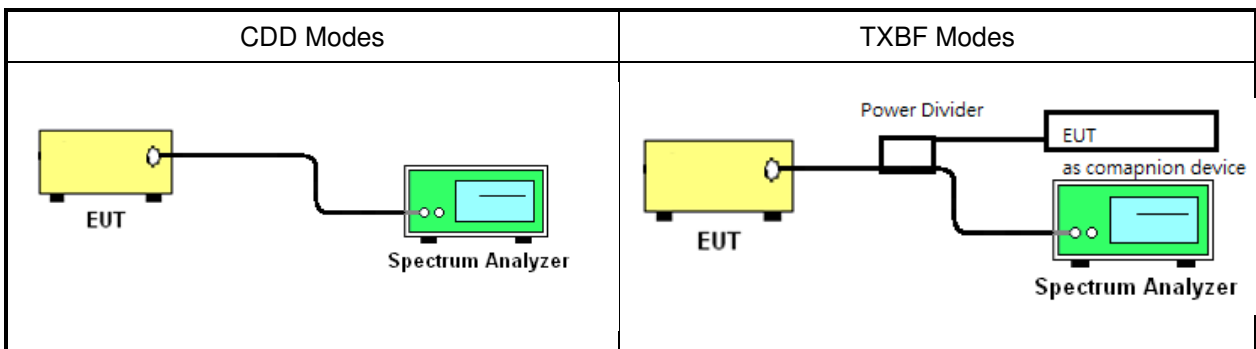

3.2.5 Test Result of Maximum Conducted Output Power

Please refer to Appendix A.



<CDD Modes>

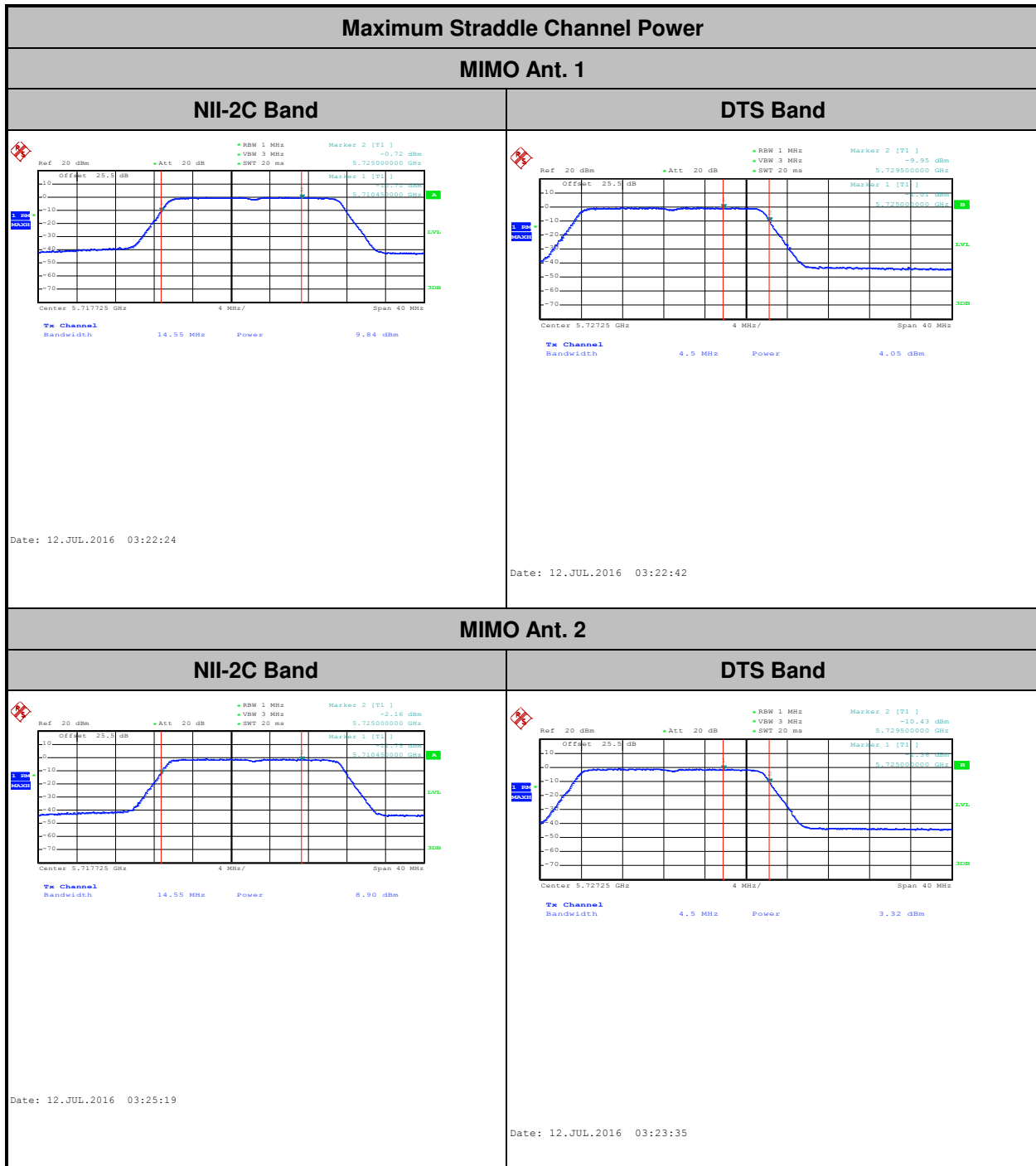



<TXBF Modes>

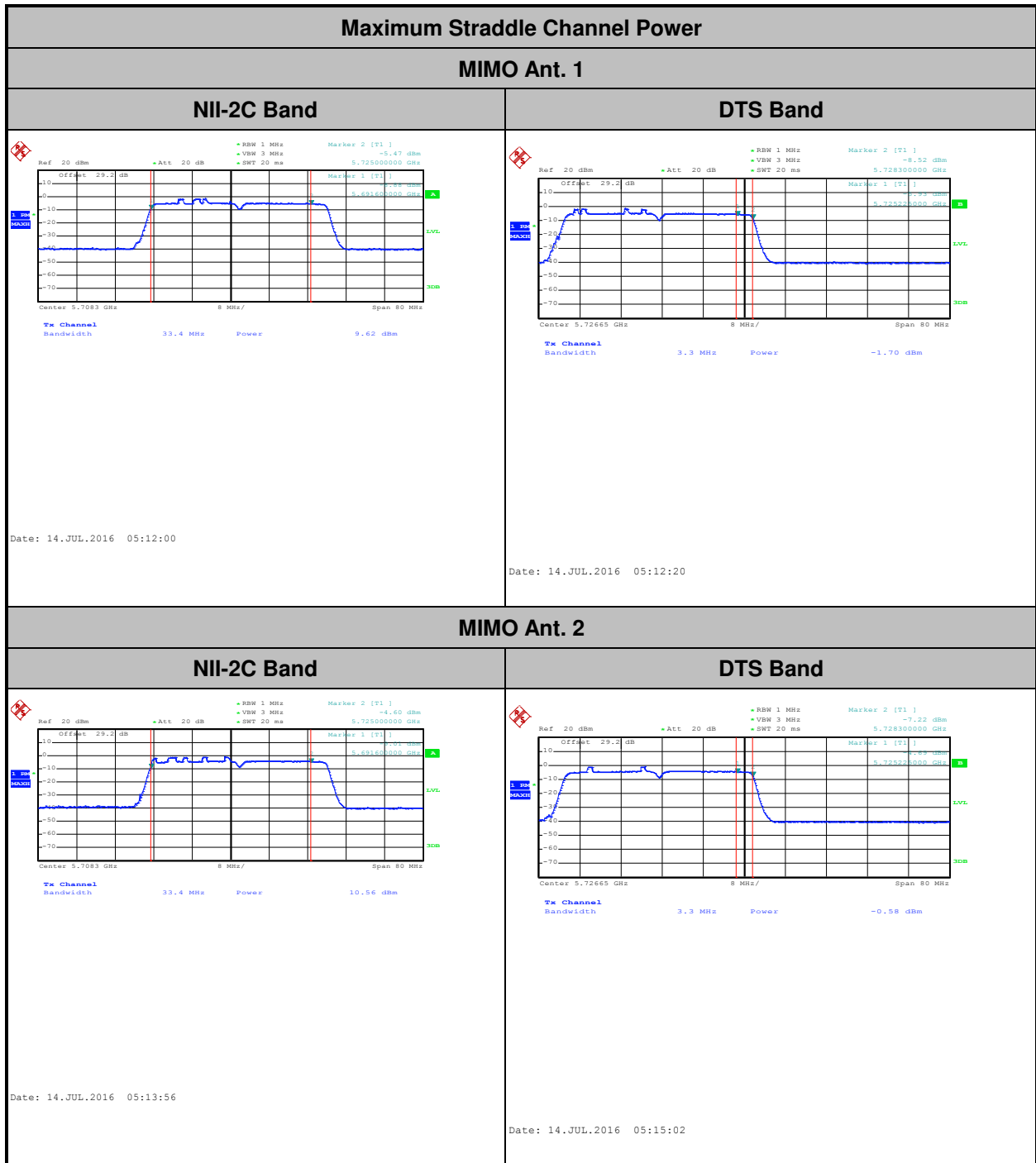



3.3 Power Spectral Density Measurement

3.3.1 Limit of Power Spectral Density

For mobile and portable client devices in the 5.15–5.25 GHz band, the maximum power spectral density shall not exceed 11dBm in any 1 megahertz band.

For the 5.25–5.35 GHz and 5.47–5.725 GHz bands, the maximum power spectral density shall not exceed 11 dBm in any 1 megahertz band.

For Straddle Channel, U-NII procedures and limits were applied for operations in the frequency band in accordance with FCC KDB 644545 D03.

If transmitting antennas of directional gain greater than 6 dBi are used, the peak output power shall be reduced by the amount in dB that the directional gain of the antenna exceeds 6 dBi.

3.3.2 Measuring Instruments

The measuring equipment is listed in the section 4 of this test report.



3.3.3 Test Procedures

The testing follows FCC KDB 789033 D02 General UNII Test Procedures New Rules v01r02.
Section F) Maximum power spectral density.

CDD modes

Method SA-2

(trace averaging across on and off times of the EUT transmissions, followed by duty cycle correction).

- Measure the duty cycle.
- Set span to encompass the entire emission bandwidth (EBW) of the signal.
- Set RBW = 1 MHz.
- Set VBW \geq 3 MHz.
- Number of points in sweep \geq 2 Span / RBW.
- Sweep time = auto.
- Detector = RMS
- Trace average at least 100 traces in power averaging mode.
- Add $10 \log(1/x)$, where x is the duty cycle, to the measured power in order to compute the average power during the actual transmission times. For example, add $10 \log(1/0.25) = 6$ dB if the duty cycle is 25 percent.

TXBF modes

Method SA-3

(power averaging (rms) detection with max hold):

- Set span to encompass the entire emission bandwidth (EBW) of the signal.
- Set RBW = 1 MHz.
- Set VBW \geq 3 MHz
- Number of points in sweep \geq 2 Span / RBW.
- Sweep time \leq (number of points in sweep) \times T, when duty cycle is less than 98 percent where T is the minimum transmission duration over which the transmitter is on and is transmitting at its maximum power control level for the tested mode of operation.
- Detector = power averaging (rms).
- Trace mode = max hold.
- Allow max hold to run for at least 60 seconds, or longer as needed to allow the trace to stabilize.

1. The RF output of EUT was connected to the spectrum analyzer by a low loss cable.
2. Each plot has already offset with cable loss, and attenuator loss. Measure the PPSD and record it.
3. For MIMO mode, calculation method follows FCC KDB 662911 D01 Multiple Transmitter Output v02r01.

Method (a): Measure and sum the spectra across the outputs.

The total final Power Spectral Density is from a device with 2 transmitter outputs. The spectrum measurements of the individual outputs are all performed with the same span and number of points, the spectrum value in the first spectral bin of output 1 is summed with that in the first spectral bin of output 2 to obtain the value for the first frequency bin of the summed spectrum.

3.3.4 Test Setup

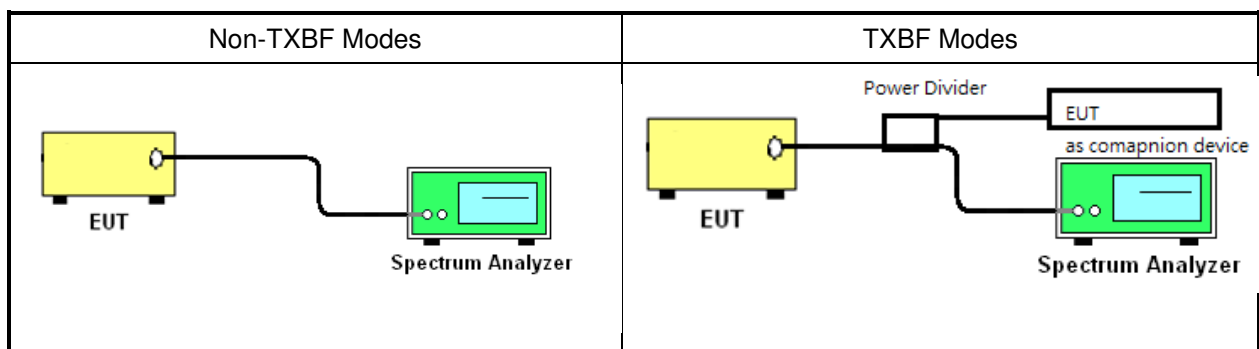

3.3.5 Test Result of Power Spectral Density

Please refer to Appendix A.



<CDD Modes>

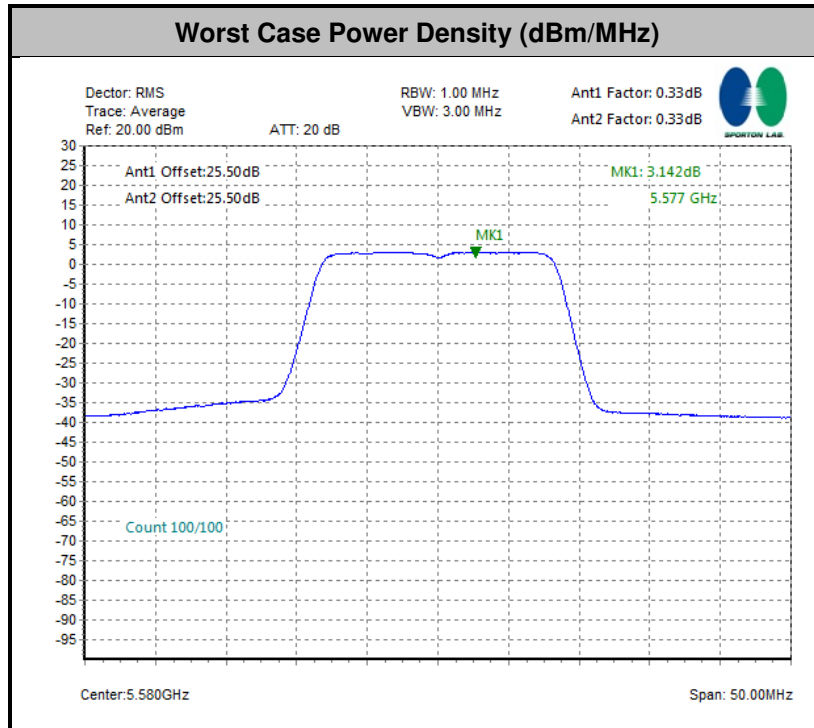

Note: Average Power Density (dB) = Measured value+ Duty Factor

<TXBF Modes>

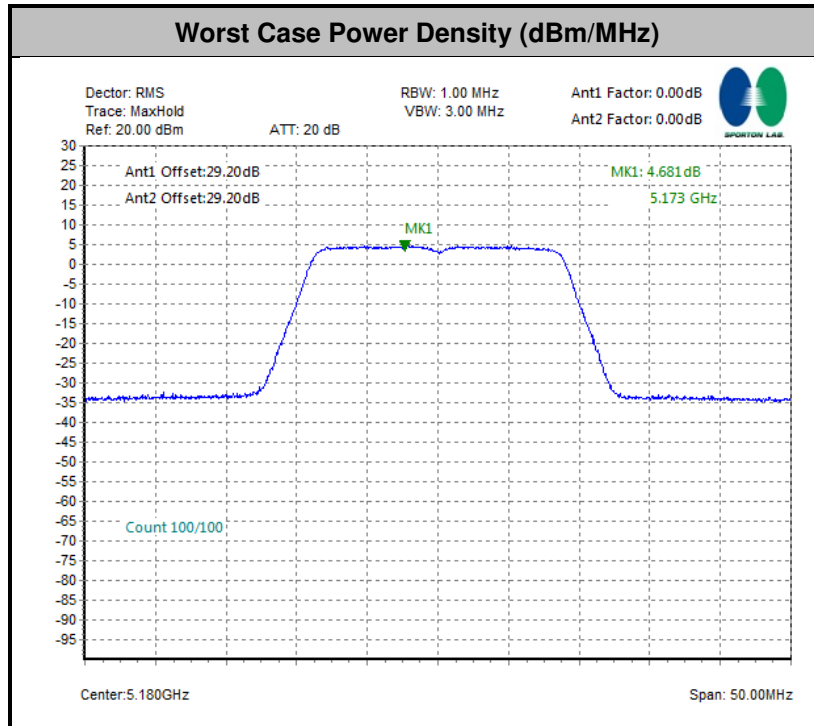

Note: Average Power Density (dB) = Measured value+ Duty Factor



3.4 Unwanted Emissions Measurement

This section as specified in FCC Part 15.407(b) is to measure unwanted emissions through radiated measurement for band edge spurious emissions and out of band emissions measurement. The unwanted emissions shall comply with 15.407(b)(1) to (6), and restricted bands per FCC Part15.205.

3.4.1 Limit of Unwanted Emissions

(1) For transmitters operating in the 5150-5250 MHz band: all emissions outside of the 5150-5350 MHz band shall not exceed an EIRP of -27dBm/MHz.

For transmitters operating in the 5250-5350 MHz band: all emissions outside of the 5150-5350 MHz band shall not exceed an EIRP of -27 dBm/MHz. Devices operating in the 5250-5350 MHz band that generate emissions in the 5150-5250 MHz band must meet all applicable technical requirements for operation in the 5150-5250 MHz band (including indoor use) or alternatively meet an out-of-band emission EIRP limit of -27 dBm/MHz in the 5150-5250 MHz band.

For transmitters operating in the 5470-5600 MHz and 5650-5725MHz band: all emissions outside of the 5470-5600 MHz and 5650-5725MHz band shall not exceed an EIRP of -27 dBm/MHz.

(2) Unwanted spurious emissions fallen in restricted bands per FCC Part15.205 shall comply with the general field strength limits set forth in § 15.209 as below table,

Frequency (MHz)	Field Strength (microvolts/meter)	Measurement Distance (meters)
0.009 – 0.490	2400/F(kHz)	300
0.490 – 1.705	24000/F(kHz)	30
1.705 – 30.0	30	30
30 – 88	100	3
88 – 216	150	3
216 - 960	200	3
Above 960	500	3

Note: The following formula is used to convert the EIRP to field strength.

$$E = \frac{1000000\sqrt{30P}}{3} \mu\text{V/m, where P is the eirp (Watts)}$$

EIRP (dBm)	Field Strength at 3m (dBμV/m)
-17	78.3
- 27	68.3



- (3) KDB789033 D02 v01r02 G)2)c) As specified in 15.407(b), emissions above 1000 MHz that are outside of the restricted bands are subject to a peak emission limit of -27 dBm/MHz (or -17 dBm/MHz as specified in 15.407(b)(4)). However, an out-of-band emission that complies with both the average and peak limits of 15.209 is not required to satisfy the -27 dBm/MHz or -17 dBm/MHz peak emission limit.

3.4.2 Measuring Instruments

The measuring equipment is listed in the section 4 of this test report.

3.4.3 Test Procedures

1. The testing follows FCC KDB 789033 D02 General UNII Test Procedures New Rules v01r02. Section G) Unwanted emissions measurement.
 - (1) Procedure for Unwanted Emissions Measurements Below 1000MHz
 - RBW = 120 kHz
 - VBW = 300 kHz
 - Detector = Peak
 - Trace mode = max hold
 - (2) Procedure for Peak Unwanted Emissions Measurements Above 1000 MHz
 - RBW = 1 MHz
 - VBW \geq 3 MHz
 - Detector = Peak
 - Sweep time = auto
 - Trace mode = max hold
 - (3) Procedures for Average Unwanted Emissions Measurements Above 1000MHz
 - RBW = 1 MHz
 - VBW = 10 Hz, when duty cycle is no less than 98 percent.
 - VBW \geq 1/T, when duty cycle is less than 98 percent where T is the minimum transmission duration over which the transmitter is on and is transmitting at its maximum power control level for the tested mode of operation.
2. The EUT was placed on a turntable with 0.8 meter for frequency below 1GHz and 1.5 meter for frequency above 1GHz respectively above ground.
3. The EUT was set 3 meters from the interference receiving antenna which was mounted on the top of a variable height antenna tower.
4. The antenna is a broadband antenna and its height is adjusted between one meter and four meters above ground to find the maximum value of the field strength for both horizontal polarization and vertical polarization of the antenna.

5. For each suspected emission, the EUT was arranged to its worst case and then adjust the antenna tower (from 1 m to 4 m) and turntable (from 0 degree to 360 degrees) to find the maximum reading.
6. For testing below 1GHz, if the emission level of the EUT in peak mode was 3 dB lower than the limit specified, then peak values of EUT will be reported, otherwise, the emissions will be repeated one by one using the CISPR quasi-peak method and reported.
7. For testing above 1GHz, the emission level of the EUT in peak mode was 20dB lower than average limit (that means the emission level in average mode also complies with the limit in average mode), then peak values of EUT will be reported, otherwise, the emissions will be measured in average mode again and reported.

3.4.4 Test Setup

For radiated emissions below 30MHz

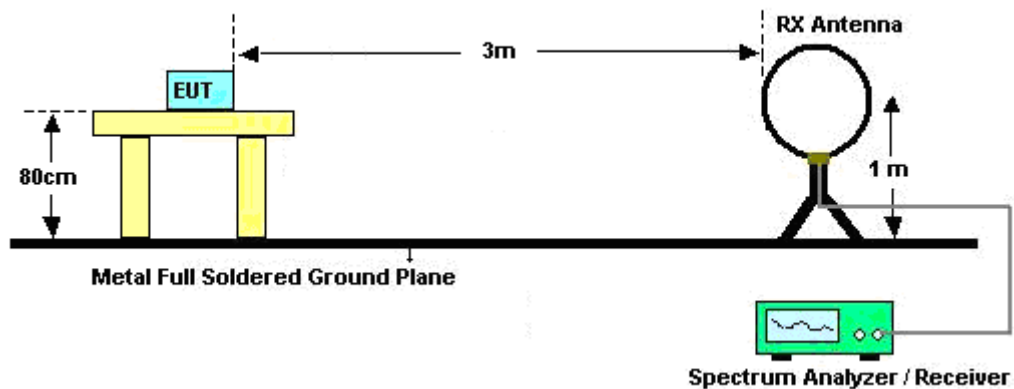

For radiated emissions from 30MHz to 1GHz

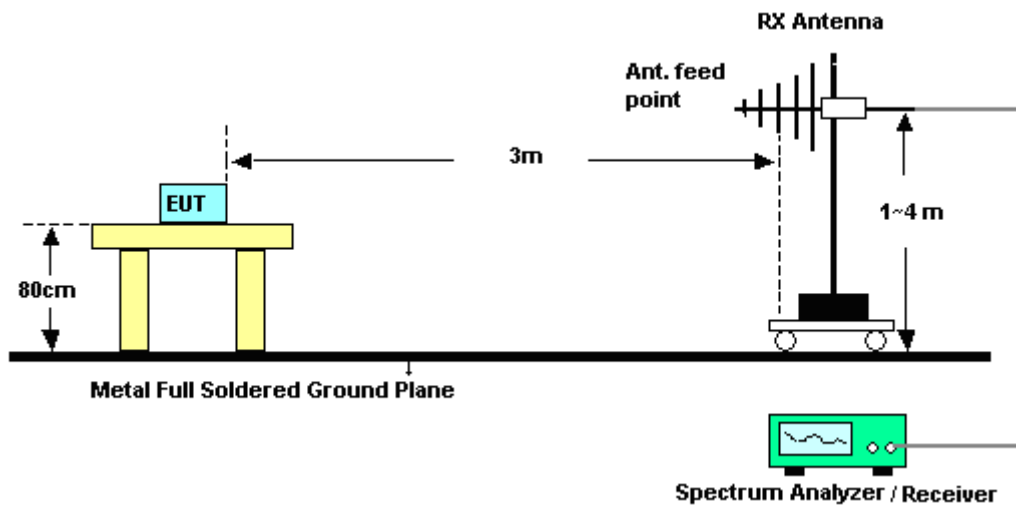

For radiated emissions above 1GHz

<CDD Modes>

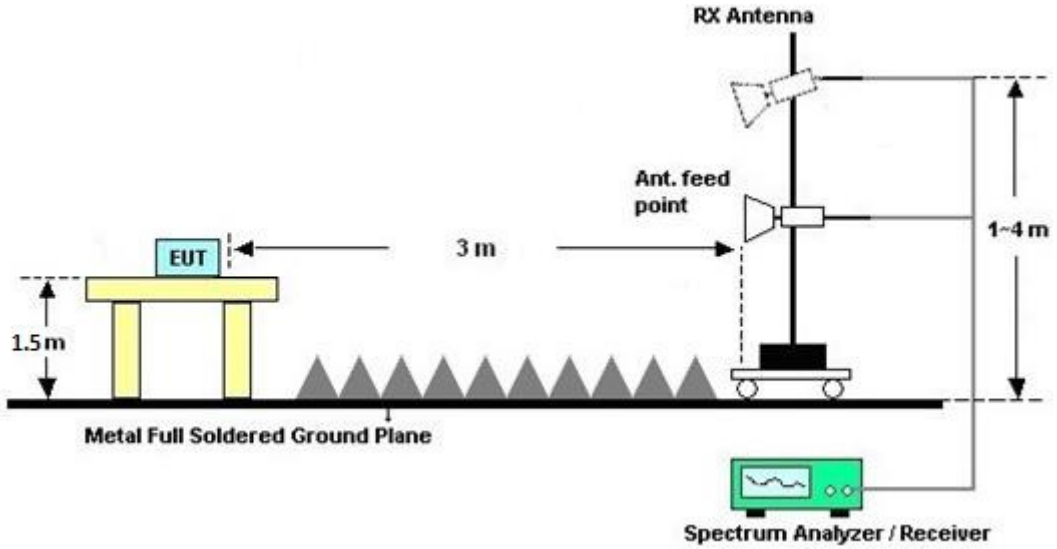

<TXBF Modes>

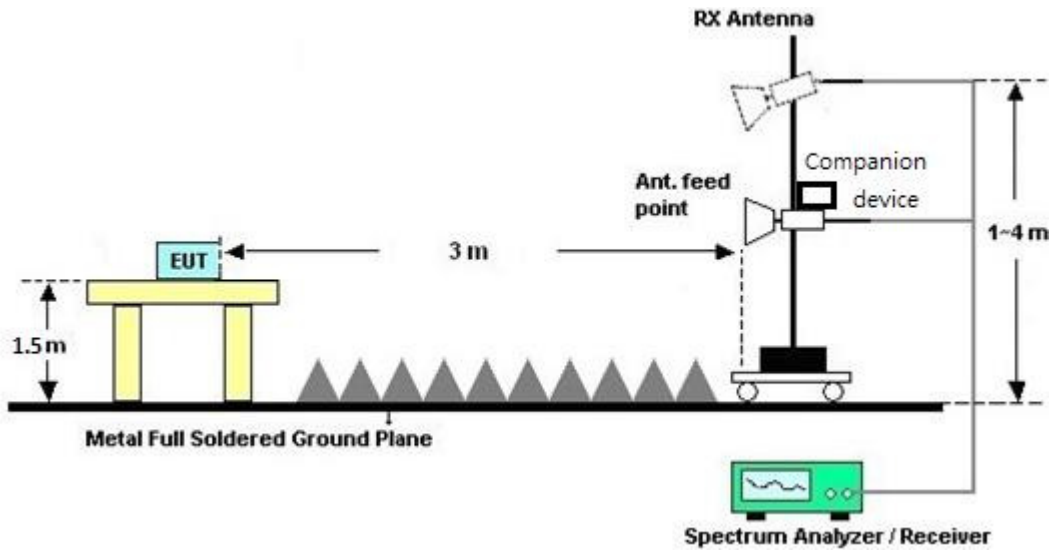



3.4.5 Test Results of Radiated Emissions (9 kHz ~ 30 MHz)

The low frequency, which started from 9 kHz to 30MHz, was pre-scanned and the result which was 20dB lower than the limit line per 15.31(o) was not reported.

3.4.6 Test Result of Radiated Band Edges

Please refer to Appendix B and C.

3.4.7 Duty Cycle

Please refer to Appendix D.

3.4.8 Test Result of Unwanted Radiated Emission (30MHz ~ 10th Harmonic)

Please refer to Appendix B and C.



3.5 AC Conducted Emission Measurement

3.5.1 Limit of AC Conducted Emission

For equipment that is designed to be connected to the public utility (AC) power line, the radio frequency voltage that is conducted back onto the AC power line on any frequency or frequencies within the band 150 kHz to 30 MHz shall not exceed the limits in the following table.

Frequency of emission (MHz)	Conducted limit (dB μ V)	
	Quasi-peak	Average
0.15-0.5	66 to 56*	56 to 46*
0.5-5	56	46
5-30	60	50

*Decreases with the logarithm of the frequency.

3.5.2 Measuring Instruments

The measuring equipment is listed in the section 4 of this test report.

3.5.3 Test Procedures

1. The EUT was placed 0.4 meter from the conducting wall of the shielding room was kept at least 80 centimeters from any other grounded conducting surface.
2. Connect EUT to the power mains through a line impedance stabilization network (LISN).
3. All the support units are connecting to the other LISN.
4. The LISN provides 50 ohm coupling impedance for the measuring instrument.
5. The FCC states that a 50 ohm, 50 microhenry LISN should be used.
6. Both sides of AC line were checked for maximum conducted interference.
7. The frequency range from 150 kHz to 30 MHz was searched.
8. Set the test-receiver system to Peak Detect Function and specified bandwidth with Maximum Hold Mode.

3.5.4 Test Setup

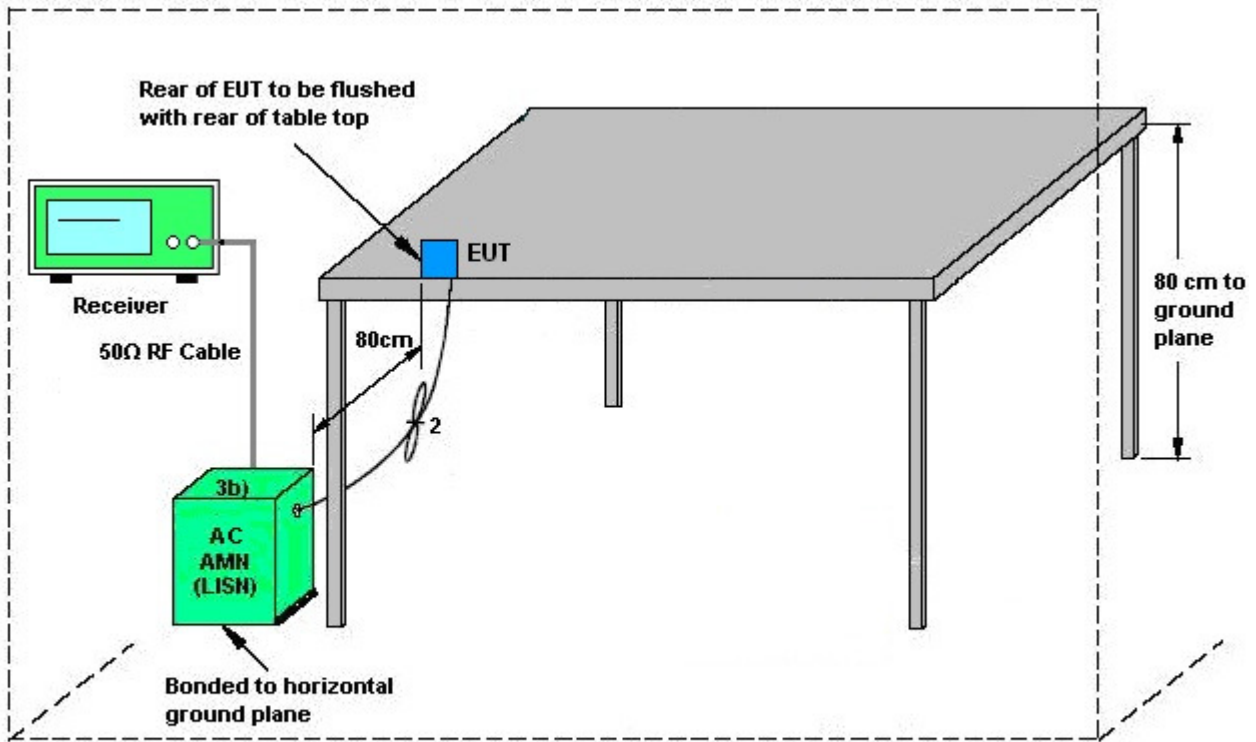

AMN = Artificial mains network (LISN)
AE = Associated equipment
EUT = Equipment under test
ISN = Impedance stabilization network



3.5.5 Test Result of AC Conducted Emission

Test Mode :	Mode 1	Temperature :	25~26°C
Test Engineer :	Arthur Hsieh	Relative Humidity :	54~55%
Test Voltage :	120Vac / 60Hz	Phase :	Line
Function Type :	Bluetooth Link + WLAN (5GHz) Link + USB Cable (Charging from Adapter) + Earphone + Battery		

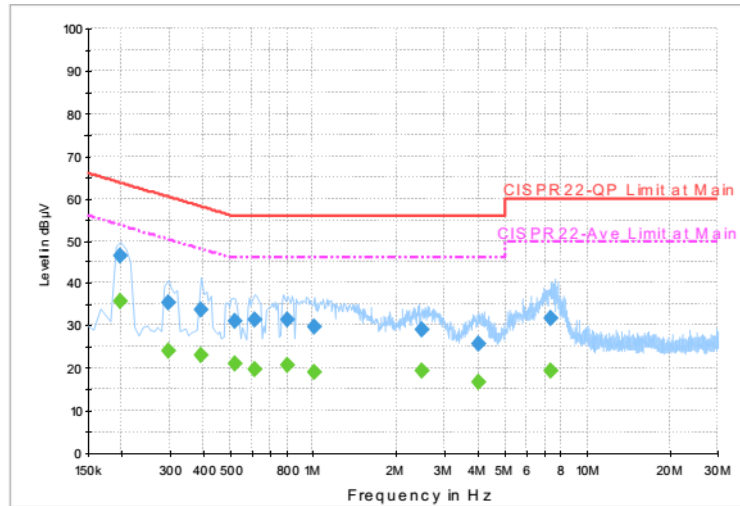

Final Result : QuasiPeak

Frequency (MHz)	QuasiPeak (dBµV)	Filter	Line	Corr. (dB)	Margin (dB)	Limit (dBµV)
0.198000	46.6	Off	L1	19.6	17.1	63.7
0.294000	35.4	Off	L1	19.6	25.0	60.4
0.390000	33.6	Off	L1	19.6	24.5	58.1
0.518000	31.2	Off	L1	19.6	24.8	56.0
0.614000	31.5	Off	L1	19.6	24.5	56.0
0.806000	31.6	Off	L1	19.6	24.4	56.0
1.006000	29.7	Off	L1	19.7	26.3	56.0
2.478000	29.1	Off	L1	19.7	26.9	56.0
4.030000	25.9	Off	L1	19.8	30.1	56.0
7.390000	31.8	Off	L1	20.0	28.2	60.0

Final Result : Average

Frequency (MHz)	Average (dBµV)	Filter	Line	Corr. (dB)	Margin (dB)	Limit (dBµV)
0.198000	35.9	Off	L1	19.6	17.8	53.7
0.294000	24.0	Off	L1	19.6	26.4	50.4
0.390000	23.1	Off	L1	19.6	25.0	48.1
0.518000	20.9	Off	L1	19.6	25.1	46.0
0.614000	19.7	Off	L1	19.6	26.3	46.0
0.806000	20.8	Off	L1	19.6	25.2	46.0
1.006000	19.2	Off	L1	19.7	26.8	46.0
2.478000	19.5	Off	L1	19.7	26.5	46.0
4.030000	16.6	Off	L1	19.8	29.4	46.0
7.390000	19.5	Off	L1	20.0	30.5	50.0



Test Mode :	Mode 1	Temperature :	25~26°C
Test Engineer :	Arthur Hsieh	Relative Humidity :	54~55%
Test Voltage :	120Vac / 60Hz	Phase :	Neutral
Function Type :	Bluetooth Link + WLAN (5GHz) Link + USB Cable (Charging from Adapter) + Earphone + Battery		

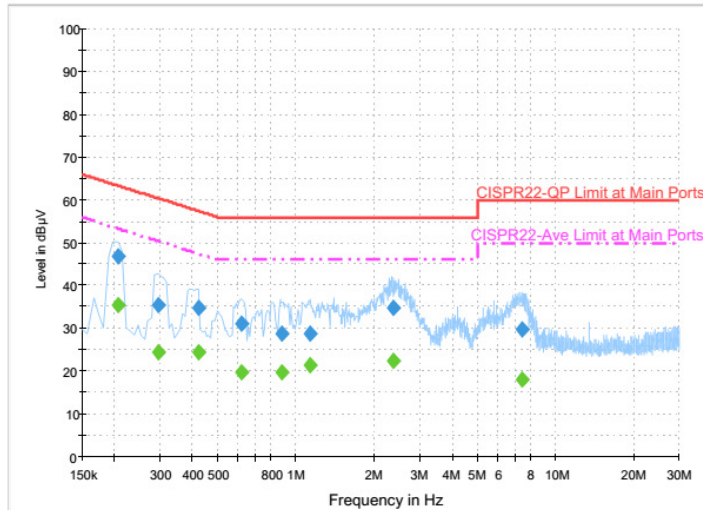

Final Result : QuasiPeak

Frequency (MHz)	QuasiPeak (dBµV)	Filter	Line	Corr. (dB)	Margin (dB)	Limit (dBµV)
0.206000	46.7	Off	N	19.6	16.7	63.4
0.294000	35.6	Off	N	19.6	24.8	60.4
0.422000	34.8	Off	N	19.6	22.6	57.4
0.622000	31.0	Off	N	19.6	25.0	56.0
0.886000	28.6	Off	N	19.6	27.4	56.0
1.142000	28.7	Off	N	19.6	27.3	56.0
2.374000	34.8	Off	N	19.6	21.2	56.0
7.406000	29.8	Off	N	19.9	30.2	60.0

Final Result : Average

Frequency (MHz)	Average (dBµV)	Filter	Line	Corr. (dB)	Margin (dB)	Limit (dBµV)
0.206000	35.3	Off	N	19.6	18.1	53.4
0.294000	24.5	Off	N	19.6	25.9	50.4
0.422000	24.4	Off	N	19.6	23.0	47.4
0.622000	19.6	Off	N	19.6	26.4	46.0
0.886000	19.9	Off	N	19.6	26.1	46.0
1.142000	21.3	Off	N	19.6	24.7	46.0
2.374000	22.3	Off	N	19.6	23.7	46.0
7.406000	18.1	Off	N	19.9	31.9	50.0

3.6 Frequency Stability Measurement

3.6.1 Limit of Frequency Stability

Manufacturers of U-NII devices are responsible for ensuring frequency stability such that an emission is maintained within the band of operation under all conditions of normal operation as specified in the user's manual.

3.6.2 Measuring Instruments

The measuring equipment is listed in the section 4 of this test report.

3.6.3 Test Procedures

1. To ensure emission at the band edge is maintained within the authorized band, those values shall be measured by radiation emissions at upper and lower frequency points, and finally compensated by frequency deviation as procedures below.
2. The EUT was operated at the maximum output power, and connected to the spectrum analyzer, which is set to maximum hold function and peak detector. The peak value of the power envelope was measured and noted. The upper and lower frequency points were respectively measured relatively 10dB lower than the measured peak value.
3. The frequency deviation was calculated by adding the upper frequency point and the lower frequency point divided by two. Those detailed values of frequency deviation are provided in table below.

3.6.4 Test Setup

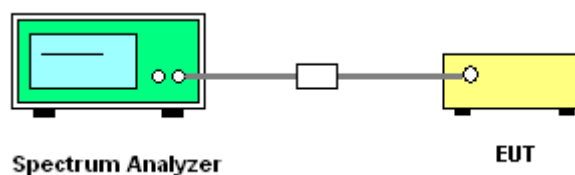

3.6.5 Test Result of Frequency Stability

Please refer to Appendix A.



3.7 Automatically Discontinue Transmission

3.7.1 Limit of Automatically Discontinue Transmission

The device shall automatically discontinue transmission in case of either absence of information to transmit or operational failure. These provisions are not intended to preclude the transmission of control or signaling information or the use of repetitive codes used by certain digital technologies to complete frame or burst intervals. Applicants shall include in their application for equipment authorization to describe how this requirement is met.

3.7.2 Measuring Instruments

The measuring equipment is listed in the section 4 of this test report.

3.7.3 Test Result of Automatically Discontinue Transmission

While the EUT is not transmitting any information, the EUT can automatically discontinue transmission and become standby mode for power saving. The EUT can detect the controlling signal of ACK message transmitting from remote device and verify whether it shall resend or discontinue transmission.



3.8 Antenna Requirements

3.8.1 Standard Applicable

According to FCC 47 CFR Section 15.407(a)(1)(2) ,if transmitting antenna directional gain is greater than 6 dBi, both the peak transmit power and the peak power spectral density shall be reduced by the amount in dB that the directional gain of the antenna exceeds 6 dBi.

3.8.2 Antenna Anti-Replacement Construction

An embedded-in antenna design is used.



3.8.3 Antenna Gain

CDD modes

FCC KDB 662911 D01 Multiple Transmitter Output v02r01

For CDD transmissions, directional gain is calculated as

Directional gain = G_{ANT} + Array Gain, where Array Gain is as follows.

For power spectral density (PSD) measurements on all devices,

Array Gain = $10 \log(N_{ANT}/N_{SS}=1)$ dB.

For power measurements on IEEE 802.11 devices,

Array Gain = 0 dB (i.e., no array gain) for $N_{ANT} \leq 4$.

Directional gain may be calculated by using the formulas applicable to equal gain antennas with G_{ANT} set equal to the gain of the antenna having the highest gain;

The EUT supports CDD mode.

For power, the directional gain G_{ANT} is set equal to the antenna having the highest gain, i.e., F)2)f)i).

For PSD, the directional gain calculation is following F)2)f)ii) of KDB 662911 D01 v02r01.

The power and PSD limit should be modified if the directional gain of EUT is over 6 dBi,

The directional gain "DG" is calculated as following table.

			DG for Power (dBi)	DG for PSD (dBi)	Power Limit Reduction (dB)	PSD Limit Reduction (dB)
	Ant 1 (dBi)	Ant 2 (dBi)				
Band I	1.40	1.00	1.40	4.21	0.00	0.00
Band II	1.40	1.00	1.40	4.21	0.00	0.00
Band III	1.60	0.90	1.60	4.27	0.00	0.00

Power limit reduction = Composite gain – 6dBi, (min = 0)

PSD limit reduction = Composite gain + PSD Array gain – 6dBi, (min = 0)

TXBF modes

FCC KDB 662911 D01 Multiple Transmitter Output v02r01

For CDD transmissions, directional gain is calculated as

$$DirectionalGain = 10 \cdot \log \left[\frac{\sum_{j=1}^{N_{SS}} \left\{ \sum_{k=1}^{N_{ANT}} g_{j,k} \right\}^2}{N_{ANT}} \right]$$

where

Each antenna is driven by no more than one spatial stream;

N_{SS} = the number of independent spatial streams of data;

N_{ANT} = the total number of antennas

$g_{j,k} = 10^{G_k / 20}$ if the k th antenna is being fed by spatial stream j , or zero if it is not;
 G_k is the gain in dBi of the k th antenna.

The EUT supports beamforming for 802.11ac modes.

The directional gain calculation is following F)2)e)ii) of KDB 662911 D01 v02r01.

The power and PSD limit should be modified if the directional gain of EUT is over 6 dBi,

The directional gain “DG” is calculated as following table.

			DG	DG	Power	PSD
			for	for	Limit	Limit
	Ant 1	Ant 2	Power	PSD	Reduction	Reduction
	(dBi)	(dBi)	(dBi)	(dBi)	(dB)	(dB)
Band I	1.40	1.00	4.21	4.21	0.00	0.00
Band II	1.40	1.00	4.21	4.21	0.00	0.00
Band III	1.60	0.90	4.27	4.27	0.00	0.00

$Power\ Limit\ Reduction = DG(Power) - 6dBi, (min = 0)$

$PSD\ Limit\ Reduction = DG(PSD) - 6dBi, (min = 0)$



4 List of Measuring Equipment

Instrument	Manufacturer	Model No.	Serial No.	Characteristics	Calibration Date	Test Date	Due Date	Remark
Power Sensor	DARE	RadiPower	15I00041SN O09	10MHz~6GHz	May 03, 2016	Jun. 20, 2016 ~ Jul. 21, 2016	May 02, 2017	Conducted (TH05-HY)
Power Meter	Anritsu	ML2495A	1132003	300MHz~40GHz	Aug. 12, 2015	Jun. 20, 2016 ~ Jul. 21, 2016	Aug. 11, 2016	Conducted (TH05-HY)
Power Sensor	DARE	RadiPower	15I00041SN O10	10MHz~6GHz	May 03, 2016	Jun. 20, 2016 ~ Jul. 21, 2016	May 02, 2017	Conducted (TH05-HY)
Power Sensor	Anritsu	MA2411B	1126017	300MHz~40GHz	Aug. 12, 2015	Jun. 20, 2016 ~ Jul. 21, 2016	Aug. 11, 2016	Conducted (TH05-HY)
Spectrum Analyzer	Rohde & Schwarz	FSP40	100057	9kHz-40GHz	Nov. 23, 2015	Jun. 20, 2016 ~ Jul. 21, 2016	Nov. 22, 2016	Conducted (TH05-HY)
Temperature Chamber	ESPEC	SU-241	92003713	-30℃ ~95℃	Jun. 06, 2016	Jun. 20, 2016 ~ Jul. 21, 2016	Jun. 05, 2017	Conducted (TH05-HY)
AC Power Source	ChainTek	APC-1000W	N/A	N/A	N/A	Jun. 13, 2016	N/A	Conduction (CO05-HY)
EMI Test Receiver	Rohde & Schwarz	ESCI 7	100724	9kHz~7GHz	Aug. 26, 2015	Jun. 13, 2016	Aug. 25, 2016	Conduction (CO05-HY)
LISN	Rohde & Schwarz	ENV216	100080	9kHz~30MHz	Dec. 02, 2015	Jun. 13, 2016	Dec. 01, 2016	Conduction (CO05-HY)
Bilog Antenna	TESEQ	CBL 6111D	35419	30MHz to 1GHz	Jan. 13, 2016	Jun. 22, 2016 ~ Jul. 17, 2016	Jan. 12, 2017	Radiation (03CH07-HY)
Double Ridge Horn Antenna	ESCO	3117	00075962	1GHz ~ 18GHz	Aug. 21, 2015	Jun. 22, 2016 ~ Jul. 17, 2016	Aug. 20, 2016	Radiation (03CH07-HY)
EMI Test Receiver	Keysight	N9038A(MXE)	MY54130085	20Hz ~ 8.4GHz	Nov. 04, 2015	Jun. 22, 2016 ~ Jul. 17, 2016	Nov. 03, 2016	Radiation (03CH07-HY)
Loop Antenna	Rohde & Schwarz	HFH2-Z2	100315	9 kHz~30 MHz	Sep. 02, 2015	Jun. 22, 2016 ~ Jul. 17, 2016	Sep. 01, 2016	Radiation (03CH07-HY)
Preamplifier	MITEQ	AMF-7D-0010 1800-30-10P	1590075	1GHz ~ 18GHz	Apr. 15, 2016	Jun. 22, 2016 ~ Jul. 17, 2016	Apr. 14, 2017	Radiation (03CH07-HY)
Preamplifier	COM-POWER	PA-103A	161241	10MHz-1GHz	Mar. 18, 2016	Jun. 22, 2016 ~ Jul. 17, 2016	Mar. 17, 2017	Radiation (03CH07-HY)
Preamplifier	Agilent	8449B	3008A02362	1GHz~ 26.5GHz	Oct. 19, 2015	Jun. 22, 2016 ~ Jul. 17, 2016	Oct. 18, 2016	Radiation (03CH07-HY)
Spectrum Analyzer	Agilent	N9010A	MY53470118	10Hz~44GHz	Feb. 27, 2016	Jun. 22, 2016 ~ Jul. 17, 2016	Feb. 26, 2017	Radiation (03CH07-HY)
Antenna Mast	Max-Full	MFA520BS	N/A	1m~4m	N/A	Jun. 22, 2016 ~ Jul. 17, 2016	N/A	Radiation (03CH07-HY)
Turn Table	ChainTek	Chaintek 3000	N/A	0~360 Degree	N/A	Jun. 22, 2016 ~ Jul. 17, 2016	N/A	Radiation (03CH07-HY)
Loop Cable	Rohde & Schwarz	N/A	N/A	9KHz~30MHz	Dec. 03, 2015	Jun. 22, 2016 ~ Jul. 17, 2016	Dec. 02, 2016	Radiation (03CH07-HY)
Preamplifier	MITEQ	TTA0204	1872107	2GHz~40GHz	Feb. 15, 2015	Jun. 22, 2016 ~ Jul. 17, 2016	Feb. 14, 2017	Radiation (03CH07-HY)
SHF-EHF Horn Antenna	SCHWARZBE CK	BBHA 9170	BBHA917058 4	18GHz- 40GHz	Nov. 02, 2015	Jun. 22, 2016 ~ Jul. 17, 2016	Nov. 01, 2016	Radiation (03CH07-HY)



5 Uncertainty of Evaluation

Uncertainty of Conducted Emission Measurement (150kHz ~ 30MHz)

Measuring Uncertainty for a Level of Confidence of 95% ($U = 2Uc(y)$)	2.26
---	------

Uncertainty of Radiated Emission Measurement (30 MHz ~ 1000 MHz)

Measuring Uncertainty for a Level of Confidence of 95% ($U = 2Uc(y)$)	5.6
---	-----



Appendix A. Conducted Test Results

<CDD Modes>

Test Engineer:	Luffy Lin, Tommy Lee, and An Wu	Temperature:	21~25	°C
Test Date:	2016/06/20 ~ 2016/07/21	Relative Humidity:	51~54	%

TEST RESULTS DATA
26dB and 99% OBW

Band I													
Mod.	Data Rate	NTX	CH.	Freq. (MHz)	99% Bandwidth (MHz)		26 dB Bandwidth (MHz)		IC 99% Bandwidth Power Limit (dBm)		IC 99% Bandwidth EIRP Limit (dBm)		Note
					Ant 1	Ant 2	Ant 1	Ant 2	Ant 1	Ant 2	Ant 1	Ant 2	
11a	6Mbps	2	36	5180	18.05	18.10	23.00	22.90	-	-	22.56	-	
11a	6Mbps	2	44	5220	18.20	18.00	23.00	22.80	-	-	22.55	-	
11a	6Mbps	2	48	5240	17.30	17.25	20.60	20.50	-	-	22.37	-	
HT20	MCS0	2	36	5180	19.00	18.95	23.30	23.10	-	-	22.78	-	
HT20	MCS0	2	44	5220	19.10	18.80	23.30	23.00	-	-	22.74	-	
HT20	MCS0	2	48	5240	18.05	18.00	20.80	20.90	-	-	22.55	-	
HT40	MCS0	2	38	5190	36.70	36.80	41.22	41.04	-	-	23.01	-	
HT40	MCS0	2	46	5230	36.80	36.80	41.40	41.04	-	-	23.01	-	
VHT20	MCS0	2	36	5180	19.10	19.00	23.40	23.00	-	-	22.79	-	
VHT20	MCS0	2	44	5220	19.00	19.10	23.20	22.90	-	-	22.79	-	
VHT20	MCS0	2	48	5240	18.00	18.05	20.90	20.90	-	-	22.55	-	
VHT40	MCS0	2	38	5190	36.70	36.70	41.58	41.22	-	-	23.01	-	
VHT40	MCS0	2	46	5230	36.70	36.70	41.22	41.40	-	-	23.01	-	
VHT80	MCS0	2	42	5210	75.84	75.96	81.92	81.92	-	-	23.01	-	

TEST RESULTS DATA
Average Power Table

FCC Band I														
Mod.	Data Rate	NTX	CH.	Freq. (MHz)	Duty Factor (dB)		Average Conducted Power (dBm)			FCC Conducted Power Limit (dBm)		DG (dBi)		Pass/Fail
					Ant 1	Ant 2	Ant 1	Ant 2	SUM	Ant 1	Ant 2	Ant 1	Ant 2	
11a	6Mbps	1	36	5180	0.33	0.33	11.31	11.16		24.00	24.00	1.40	1.00	Pass
11a	6Mbps	1	44	5220	0.33	0.33	11.33	11.30		24.00	24.00	1.40	1.00	Pass
11a	6Mbps	1	48	5240	0.33	0.33	11.24	11.32		24.00	24.00	1.40	1.00	Pass
HT20	MCS0	1	36	5180	0.31	0.31	11.31	11.17		24.00	24.00	1.40	1.00	Pass
HT20	MCS0	1	44	5220	0.31	0.31	11.37	11.38		24.00	24.00	1.40	1.00	Pass
HT20	MCS0	1	48	5240	0.31	0.31	11.26	11.32		24.00	24.00	1.40	1.00	Pass
HT40	MCS0	1	38	5190	0.61	0.61	11.38	11.43		24.00	24.00	1.40	1.00	Pass
HT40	MCS0	1	46	5230	0.61	0.61	11.30	11.26		24.00	24.00	1.40	1.00	Pass
VHT20	MCS0	1	36	5180	0.31	0.31	11.36	11.26		24.00	24.00	1.40	1.00	Pass
VHT20	MCS0	1	44	5220	0.31	0.31	11.34	11.39		24.00	24.00	1.40	1.00	Pass
VHT20	MCS0	1	48	5240	0.31	0.31	11.22	11.24		24.00	24.00	1.40	1.00	Pass
VHT40	MCS0	1	38	5190	0.66	0.63	11.47	11.46		24.00	24.00	1.40	1.00	Pass
VHT40	MCS0	1	46	5230	0.66	0.63	11.35	11.33		24.00	24.00	1.40	1.00	Pass
VHT80	MCS0	1	42	5210	1.14	1.16	10.89	10.90		24.00	24.00	1.40	1.00	Pass
11a	6Mbps	2	36	5180	0.33	0.33	11.49	11.12	14.32	24.00		1.40		Pass
11a	6Mbps	2	44	5220	0.33	0.33	11.62	11.02	14.34	24.00		1.40		Pass
11a	6Mbps	2	48	5240	0.33	0.33	11.69	11.05	14.39	24.00		1.40		Pass
HT20	MCS0	2	36	5180	0.31	0.35	11.66	11.07	14.38	24.00		1.40		Pass
HT20	MCS0	2	44	5220	0.31	0.35	11.74	10.98	14.39	24.00		1.40		Pass
HT20	MCS0	2	48	5240	0.31	0.35	11.67	11.01	14.36	24.00		1.40		Pass
HT40	MCS0	2	38	5190	0.68	0.64	11.77	11.15	14.48	24.00		1.40		Pass
HT40	MCS0	2	46	5230	0.68	0.64	11.61	10.97	14.31	24.00		1.40		Pass
VHT20	MCS0	2	36	5180	0.35	0.35	11.67	11.04	14.37	24.00		1.40		Pass
VHT20	MCS0	2	44	5220	0.35	0.35	11.76	11.07	14.44	24.00		1.40		Pass
VHT20	MCS0	2	48	5240	0.35	0.35	11.75	10.98	14.39	24.00		1.40		Pass
VHT40	MCS0	2	38	5190	0.63	0.63	11.73	11.21	14.49	24.00		1.40		Pass
VHT40	MCS0	2	46	5230	0.63	0.63	11.71	10.93	14.35	24.00		1.40		Pass
VHT80	MCS0	2	42	5210	1.20	1.14	10.03	9.01	12.56	24.00		1.40		Pass

TEST RESULTS DATA
Power Spectral Density

FCC Band I														
Mod.	Data Rate	NTX	CH.	Freq. (MHz)	Duty Factor (dB)		Average Power Density (dBm/MHz)			Average PSD Limit (dBm/MHz)		DG (dBi)		Pass /Fail
					Ant 1	Ant 2	Ant 1	Ant 2	SUM	Ant 1	Ant 2	Ant 1	Ant 2	
11a	6Mbps	2	36	5180	0.33	0.33			2.81	11.00		4.21		Pass
11a	6Mbps	2	44	5220	0.33	0.33			2.76	11.00		4.21		Pass
11a	6Mbps	2	48	5240	0.33	0.33			2.95	11.00		4.21		Pass
HT20	MCS0	2	36	5180	0.31	0.35			2.72	11.00		4.21		Pass
HT20	MCS0	2	44	5220	0.31	0.35			2.77	11.00		4.21		Pass
HT20	MCS0	2	48	5240	0.31	0.35			2.71	11.00		4.21		Pass
HT40	MCS0	2	38	5190	0.68	0.64			0.10	11.00		4.21		Pass
HT40	MCS0	2	46	5230	0.68	0.64			-0.49	11.00		4.21		Pass
VHT20	MCS0	2	36	5180	0.35	0.35			2.68	11.00		4.21		Pass
VHT20	MCS0	2	44	5220	0.35	0.35			2.84	11.00		4.21		Pass
VHT20	MCS0	2	48	5240	0.35	0.35			2.79	11.00		4.21		Pass
VHT40	MCS0	2	38	5190	0.63	0.63			0.05	11.00		4.21		Pass
VHT40	MCS0	2	46	5230	0.63	0.63			-0.23	11.00		4.21		Pass
VHT80	MCS0	2	42	5210	1.20	1.14			-1.92	11.00		4.21		Pass

TEST RESULTS DATA
26dB and 99% OBW

Band II															
Mod.	Data Rate	NTX	CH.	Freq. (MHz)	99% Bandwidth (MHz)		26 dB Bandwidth (MHz)		IC 99% Bandwidth Power Limit (dBm)		IC 99% Bandwidth EIRP Limit (dBm)		FCC 26dB Bandwidth Power Limit (dBm)		Note
					Ant 1	Ant 2	Ant 1	Ant 2	Ant 1	Ant 2	Ant 1	Ant 2	Ant 1	Ant 2	
11a	6Mbps	2	52	5260	17.15	17.20	20.40	20.60	23.34		29.34		23.98		
11a	6Mbps	2	60	5300	18.35	17.95	23.00	22.80	23.54		29.54		23.98		
11a	6Mbps	2	64	5320	18.30	18.40	22.90	22.80	23.62		29.62		23.98		
HT20	MCS0	2	52	5260	18.00	18.05	20.90	20.90	23.55		29.55		23.98		
HT20	MCS0	2	60	5300	19.00	18.90	23.50	23.20	23.76		29.76		23.98		
HT20	MCS0	2	64	5320	19.00	18.80	23.30	22.90	23.74		29.74		23.98		
HT40	MCS0	2	54	5270	36.70	36.70	41.58	41.04	23.98		30.00		23.98		
HT40	MCS0	2	62	5310	36.60	36.60	41.04	41.04	23.98		30.00		23.98		
VHT20	MCS0	2	52	5260	18.00	18.00	20.70	20.70	23.55		29.55		23.98		
VHT20	MCS0	2	60	5300	19.20	18.75	23.20	22.90	23.73		29.73		23.98		
VHT20	MCS0	2	64	5320	18.95	18.95	23.20	23.20	23.78		29.78		23.98		
VHT40	MCS0	2	54	5270	36.80	36.80	41.40	41.04	23.98		30.00		23.98		
VHT40	MCS0	2	62	5310	36.70	36.80	41.40	41.04	23.98		30.00		23.98		
VHT80	MCS0	2	58	5290	75.96	75.96	82.24	82.24	23.98		30.00		23.98		

TEST RESULTS DATA
Average Power Table

FCC Band II															
Mod.	Data Rate	NTX	CH.	Freq. (MHz)	Duty Factor (dB)		Average Conducted Power (dBm)			FCC Conducted Power Limit (dBm)		DG (dBi)		EIRP Power Limit (dBm)	Pass/Fail
					Ant 1	Ant 2	Ant 1	Ant 2	SUM	Ant 1	Ant 2	Ant 1	Ant 2		
11a	6Mbps	1	52	5260	0.33	0.33	11.38	11.44				1.40	1.00	26.99	Pass
11a	6Mbps	1	60	5300	0.33	0.33	11.32	11.29				1.40	1.00	26.99	Pass
11a	6Mbps	1	64	5320	0.33	0.33	11.31	11.26				1.40	1.00	26.99	Pass
HT20	MCS0	1	52	5260	0.31	0.31	11.31	11.30				1.40	1.00	26.99	Pass
HT20	MCS0	1	60	5300	0.31	0.31	11.32	11.33				1.40	1.00	26.99	Pass
HT20	MCS0	1	64	5320	0.31	0.31	11.13	11.37				1.40	1.00	26.99	Pass
HT40	MCS0	1	54	5270	0.61	0.61	11.34	11.23				1.40	1.00	26.99	Pass
HT40	MCS0	1	62	5310	0.61	0.61	11.20	11.31				1.40	1.00	26.99	Pass
VHT20	MCS0	1	52	5260	0.31	0.31	11.37	11.37				1.40	1.00	26.99	Pass
VHT20	MCS0	1	60	5300	0.31	0.31	11.31	11.31				1.40	1.00	26.99	Pass
VHT20	MCS0	1	64	5320	0.31	0.31	11.34	11.39				1.40	1.00	26.99	Pass
VHT40	MCS0	1	54	5270	0.66	0.63	11.31	11.33				1.40	1.00	26.99	Pass
VHT40	MCS0	1	62	5310	0.66	0.63	11.35	11.41				1.40	1.00	26.99	Pass
VHT80	MCS0	1	58	5290	1.14	1.16	10.78	10.79				1.40	1.00	26.99	Pass
11a	6Mbps	2	52	5260	0.33	0.33	11.59	11.37	14.49	23.98		1.40		26.99	Pass
11a	6Mbps	2	60	5300	0.33	0.33	11.42	11.26	14.35	23.98		1.40		26.99	Pass
11a	6Mbps	2	64	5320	0.33	0.33	11.47	11.16	14.33	23.98		1.40		26.99	Pass
HT20	MCS0	2	52	5260	0.31	0.35	11.47	11.15	14.32	23.98		1.40		26.99	Pass
HT20	MCS0	2	60	5300	0.31	0.35	11.46	11.21	14.35	23.98		1.40		26.99	Pass
HT20	MCS0	2	64	5320	0.31	0.35	11.62	11.17	14.41	23.98		1.40		26.99	Pass
HT40	MCS0	2	54	5270	0.68	0.64	11.46	11.15	14.32	23.98		1.40		26.99	Pass
HT40	MCS0	2	62	5310	0.68	0.64	11.66	11.19	14.44	23.98		1.40		26.99	Pass
VHT20	MCS0	2	52	5260	0.35	0.35	11.46	11.30	14.39	23.98		1.40		26.99	Pass
VHT20	MCS0	2	60	5300	0.35	0.35	11.44	11.18	14.32	23.98		1.40		26.99	Pass
VHT20	MCS0	2	64	5320	0.35	0.35	11.66	11.16	14.43	23.98		1.40		26.99	Pass
VHT40	MCS0	2	54	5270	0.63	0.63	11.52	11.13	14.34	23.98		1.40		26.99	Pass
VHT40	MCS0	2	62	5310	0.63	0.63	11.64	11.23	14.45	23.98		1.40		26.99	Pass
VHT80	MCS0	2	58	5290	1.20	1.14	11.04	10.59	13.83	23.98		1.40		26.99	Pass

TEST RESULTS DATA
Power Spectral Density

Band II														
Mod.	Data Rate	NTX	CH.	Freq. (MHz)	Duty Factor (dB)		Average Power Density (dBm/MHz)			Average PSD Limit (dBm/MHz)		DG (dBi)		Pass /Fail
					Ant 1	Ant 2	Ant 1	Ant 2	SUM	Ant 1	Ant 2	Ant 1	Ant 2	
11a	6Mbps	2	52	5260	0.33	0.33			3.06	11.00		4.21	Pass	
11a	6Mbps	2	60	5300	0.33	0.33			2.52	11.00		4.21	Pass	
11a	6Mbps	2	64	5320	0.33	0.33			2.56	11.00		4.21	Pass	
HT20	MCS0	2	52	5260	0.31	0.35			2.66	11.00		4.21	Pass	
HT20	MCS0	2	60	5300	0.31	0.35			2.45	11.00		4.21	Pass	
HT20	MCS0	2	64	5320	0.31	0.35			2.43	11.00		4.21	Pass	
HT40	MCS0	2	54	5270	0.68	0.64			-0.55	11.00		4.21	Pass	
HT40	MCS0	2	62	5310	0.68	0.64			-0.34	11.00		4.21	Pass	
VHT20	MCS0	2	52	5260	0.35	0.35			2.68	11.00		4.21	Pass	
VHT20	MCS0	2	60	5300	0.35	0.35			2.34	11.00		4.21	Pass	
VHT20	MCS0	2	64	5320	0.35	0.35			2.45	11.00		4.21	Pass	
VHT40	MCS0	2	54	5270	0.63	0.63			-0.40	11.00		4.21	Pass	
VHT40	MCS0	2	62	5310	0.63	0.63			-0.44	11.00		4.21	Pass	
VHT80	MCS0	2	58	5290	1.20	1.14			-3.90	11.00		4.21	Pass	

TEST RESULTS DATA
26dB and 99% OBW

Band III															
Mod.	Data Rate	NTX	CH.	Freq. (MHz)	99% Bandwidth (MHz)		26 dB Bandwidth (MHz)		IC 99% Bandwidth Power Limit (dBm)		IC 99% Bandwidth EIRP Limit (dBm)		FCC 26dB Bandwidth Power Limit (dBm)		Note
					Ant 1	Ant 2	Ant 1	Ant 2	Ant 1	Ant 2	Ant 1	Ant 2	Ant 1	Ant 2	
11a	6Mbps	1	100	5500		18.25		22.90		23.61		29.61		23.98	
11a	6Mbps	1	116	5580		17.25		20.70		23.37		29.37		23.98	
11a	6Mbps	1	140	5700		18.40		23.00		23.65		29.65		23.98	
HT20	MCS0	1	100	5500		19.15		23.50		23.82		29.82		23.98	
HT20	MCS0	1	116	5580		18.05		20.80		23.56		29.56		23.98	
HT20	MCS0	1	140	5700		18.95		23.40		23.78		29.78		23.98	
HT40	MCS0	1	102	5510		36.70		41.40		23.98		30.00		23.98	
HT40	MCS0	1	110	5550		36.70		41.76		23.98		30.00		23.98	
HT40	MCS0	1	134	5670		36.70		41.40		23.98		30.00		23.98	
VHT20	MCS0	1	100	5500		18.95		23.30		23.78		29.78		23.98	
VHT20	MCS0	1	116	5580		18.05		20.80		23.56		29.56		23.98	
VHT20	MCS0	1	140	5700		19.00		23.10		23.79		29.79		23.98	
VHT40	MCS0	1	102	5510		36.70		41.22		23.98		30.00		23.98	
VHT40	MCS0	1	110	5550		36.60		41.58		23.98		30.00		23.98	
VHT40	MCS0	1	134	5670		36.70		41.40		23.98		30.00		23.98	
VHT80	MCS0	1	106	5530		75.84		81.92		23.98		30.00		23.98	
VHT80	MCS0	1	122	5610		75.84		82.56		23.98		30.00		23.98	
11a	6Mbps	2	100	5500	18.05	18.15	22.60	22.90	23.56	29.56	23.98				
11a	6Mbps	2	116	5580	17.25	17.20	20.60	20.50	23.36	29.36	23.98				
11a	6Mbps	2	140	5700	18.35	18.05	23.00	22.80	23.56	29.56	23.98				
HT20	MCS0	2	100	5500	18.95	18.90	23.40	22.90	23.76	29.76	23.98				
HT20	MCS0	2	116	5580	18.05	18.05	20.90	20.80	23.56	29.56	23.98				
HT20	MCS0	2	140	5700	18.90	18.90	23.30	23.00	23.76	29.76	23.98				
HT40	MCS0	2	102	5510	36.60	36.80	41.58	41.22	23.98	30.00	23.98				
HT40	MCS0	2	110	5550	36.70	36.80	41.40	41.40	23.98	30.00	23.98				
HT40	MCS0	2	134	5670	36.60	36.70	41.22	41.22	23.98	30.00	23.98				
VHT20	MCS0	2	100	5500	19.00	19.00	23.20	23.10	23.79	29.79	23.98				
VHT20	MCS0	2	116	5580	18.00	18.05	20.80	20.80	23.55	29.55	23.98				
VHT20	MCS0	2	140	5700	18.95	18.95	23.20	23.00	23.78	29.78	23.98				
VHT40	MCS0	2	102	5510	36.70	36.70	41.40	41.04	23.98	30.00	23.98				
VHT40	MCS0	2	110	5550	36.60	36.80	41.22	41.22	23.98	30.00	23.98				
VHT40	MCS0	2	134	5670	36.70	36.70	41.40	40.86	23.98	30.00	23.98				
VHT80	MCS0	2	106	5530	75.96	75.96	82.56	81.92	23.98	30.00	23.98				
VHT80	MCS0	2	122	5610	75.84	75.84	81.92	81.60	23.98	30.00	23.98				

TEST RESULTS DATA
Average Power Table

FCC Band III															
Mod.	Data Rate	Nrx	CH.	Freq. (MHz)	Duty Factor (dB)		Average Conducted Power (dBm)			FCC Conducted Power Limit (dBm)		DG (dBi)		EIRP Power Limit (dBm)	Pass/Fail
					Ant 1	Ant 2	Ant 1	Ant 2	SUM	Ant 1	Ant 2	Ant 1	Ant 2		
11a	6Mbps	1	100	5500	0.33	0.33	10.42	12.76			23.98	1.60	0.90	26.99	Pass
11a	6Mbps	1	116	5580	0.33	0.33	10.48	12.64			23.98	1.60	0.90	26.99	Pass
11a	6Mbps	1	140	5700	0.33	0.33	10.37	12.60			23.98	1.60	0.90	26.99	Pass
HT20	MCS0	1	100	5500	0.31	0.31	10.19	12.77			23.98	1.60	0.90	26.99	Pass
HT20	MCS0	1	116	5580	0.31	0.31	10.21	12.67			23.98	1.60	0.90	26.99	Pass
HT20	MCS0	1	140	5700	0.31	0.31	10.42	12.73			23.98	1.60	0.90	26.99	Pass
HT40	MCS0	1	102	5510	0.61	0.61	10.35	12.77			23.98	1.60	0.90	26.99	Pass
HT40	MCS0	1	110	5550	0.61	0.61	10.21	12.62			23.98	1.60	0.90	26.99	Pass
HT40	MCS0	1	134	5670	0.61	0.61	10.33	12.82			23.98	1.60	0.90	26.99	Pass
VHT20	MCS0	1	100	5500	0.31	0.31	10.35	12.82			23.98	1.60	0.90	26.99	Pass
VHT20	MCS0	1	116	5580	0.31	0.31	10.33	12.80			23.98	1.60	0.90	26.99	Pass
VHT20	MCS0	1	140	5700	0.31	0.31	10.44	12.76			23.98	1.60	0.90	26.99	Pass
VHT40	MCS0	1	102	5510	0.66	0.63	10.48	12.81			23.98	1.60	0.90	26.99	Pass
VHT40	MCS0	1	110	5550	0.66	0.63	10.30	12.78			23.98	1.60	0.90	26.99	Pass
VHT40	MCS0	1	134	5670	0.66	0.63	10.43	12.89			23.98	1.60	0.90	26.99	Pass
VHT80	MCS0	1	106	5530	1.14	1.16	9.89	12.30			23.98	1.60	0.90	26.99	Pass
VHT80	MCS0	1	122	5610	1.14	1.16	9.88	12.29			23.98	1.60	0.90	26.99	Pass
11a	6Mbps	2	100	5500	0.33	0.33	10.84	9.82	13.37		23.98	1.60		26.99	Pass
11a	6Mbps	2	116	5580	0.33	0.33	10.95	9.94	13.48		23.98	1.60		26.99	Pass
11a	6Mbps	2	140	5700	0.33	0.33	10.64	9.95	13.32		23.98	1.60		26.99	Pass
HT20	MCS0	2	100	5500	0.31	0.35	10.92	9.90	13.45		23.98	1.60		26.99	Pass
HT20	MCS0	2	116	5580	0.31	0.35	10.96	9.89	13.47		23.98	1.60		26.99	Pass
HT20	MCS0	2	140	5700	0.31	0.35	10.52	9.94	13.25		23.98	1.60		26.99	Pass
HT40	MCS0	2	102	5510	0.68	0.64	10.71	9.62	13.21		23.98	1.60		26.99	Pass
HT40	MCS0	2	110	5550	0.68	0.64	11.00	9.75	13.43		23.98	1.60		26.99	Pass
HT40	MCS0	2	134	5670	0.68	0.64	10.61	9.76	13.22		23.98	1.60		26.99	Pass
VHT20	MCS0	2	100	5500	0.35	0.35	10.96	9.89	13.47		23.98	1.60		26.99	Pass
VHT20	MCS0	2	116	5580	0.35	0.35	10.99	9.88	13.48		23.98	1.60		26.99	Pass
VHT20	MCS0	2	140	5700	0.35	0.35	10.78	10.10	13.46		23.98	1.60		26.99	Pass
VHT40	MCS0	2	102	5510	0.63	0.63	10.83	9.80	13.36		23.98	1.60		26.99	Pass
VHT40	MCS0	2	110	5550	0.63	0.63	11.03	9.75	13.45		23.98	1.60		26.99	Pass
VHT40	MCS0	2	134	5670	0.63	0.63	10.86	10.00	13.46		23.98	1.60		26.99	Pass
VHT80	MCS0	2	106	5530	1.20	1.14	10.15	9.39	12.80		23.98	1.60		26.99	Pass
VHT80	MCS0	2	122	5610	1.20	1.14	10.31	9.25	12.82		23.98	1.60		26.99	Pass

TEST RESULTS DATA
Power Spectral Density

Band III														
Mod.	Data Rate	NTX	CH.	Freq. (MHz)	Duty Factor (dB)		Average Power Density (dBm/MHz)			Average PSD Limit (dBm/MHz)		DG (dBi)		Pass /Fail
					Ant 1	Ant 2	Ant 1	Ant 2	SUM	Ant 1	Ant 2	Ant 1	Ant 2	
11a	6Mbps	1	100	5500	0.33	0.33		2.21		11.00	11.00	1.60	0.90	Pass
11a	6Mbps	1	116	5580	0.33	0.33		2.34		11.00	11.00	1.60	0.90	Pass
11a	6Mbps	1	140	5700	0.33	0.33		1.10		11.00	11.00	1.60	0.90	Pass
HT20	MCS0	1	100	5500	0.31	0.31		1.90		11.00	11.00	1.60	0.90	Pass
HT20	MCS0	1	116	5580	0.31	0.31		2.24		11.00	11.00	1.60	0.90	Pass
HT20	MCS0	1	140	5700	0.31	0.31		1.17		11.00	11.00	1.60	0.90	Pass
HT40	MCS0	1	102	5510	0.61	0.61		-0.61		11.00	11.00	1.60	0.90	Pass
HT40	MCS0	1	110	5550	0.61	0.61		-0.73		11.00	11.00	1.60	0.90	Pass
HT40	MCS0	1	134	5670	0.61	0.61		-1.69		11.00	11.00	1.60	0.90	Pass
VHT20	MCS0	1	100	5500	0.31	0.31		2.01		11.00	11.00	1.60	0.90	Pass
VHT20	MCS0	1	116	5580	0.31	0.31		2.37		11.00	11.00	1.60	0.90	Pass
VHT20	MCS0	1	140	5700	0.31	0.31		1.19		11.00	11.00	1.60	0.90	Pass
VHT40	MCS0	1	102	5510	0.66	0.63		-0.57		11.00	11.00	1.60	0.90	Pass
VHT40	MCS0	1	110	5550	0.66	0.63		-0.72		11.00	11.00	1.60	0.90	Pass
VHT40	MCS0	1	134	5670	0.66	0.63		-1.14		11.00	11.00	1.60	0.90	Pass
VHT80	MCS0	1	106	5530	1.14	1.16		-3.99		11.00	11.00	1.60	0.90	Pass
VHT80	MCS0	1	122	5610	1.14	1.16		-4.32		11.00	11.00	1.60	0.90	Pass
11a	6Mbps	2	100	5500	0.33	0.33			1.25	11.00		4.27		Pass
11a	6Mbps	2	116	5580	0.33	0.33			3.14	11.00		4.27		Pass
11a	6Mbps	2	140	5700	0.33	0.33			2.09	11.00		4.27		Pass
HT20	MCS0	2	100	5500	0.31	0.35			2.87	11.00		4.27		Pass
HT20	MCS0	2	116	5580	0.31	0.35			2.88	11.00		4.27		Pass
HT20	MCS0	2	140	5700	0.31	0.35			1.85	11.00		4.27		Pass
HT40	MCS0	2	102	5510	0.68	0.64			-0.17	11.00		4.27		Pass
HT40	MCS0	2	110	5550	0.68	0.64			-0.10	11.00		4.27		Pass
HT40	MCS0	2	134	5670	0.68	0.64			-1.11	11.00		4.27		Pass
VHT20	MCS0	2	100	5500	0.35	0.35			2.64	11.00		4.27		Pass
VHT20	MCS0	2	116	5580	0.35	0.35			2.97	11.00		4.27		Pass
VHT20	MCS0	2	140	5700	0.35	0.35			1.85	11.00		4.27		Pass
VHT40	MCS0	2	102	5510	0.63	0.63			-0.15	11.00		4.27		Pass
VHT40	MCS0	2	110	5550	0.63	0.63			0.00	11.00		4.27		Pass
VHT40	MCS0	2	134	5670	0.63	0.63			-0.91	11.00		4.27		Pass
VHT80	MCS0	2	106	5530	1.20	1.14			-3.39	11.00		4.27		Pass
VHT80	MCS0	2	122	5610	1.20	1.14			-3.78	11.00		4.27		Pass

TEST RESULTS DATA
26dB and 99% OBW

Straddle Channel															
Mod.	Data Rate	NTX	CH.	Freq. (MHz)	99% Bandwidth (MHz)		Emission Bandwidth (MHz)		IC 99% Bandwidth Power Limit (dBm)		IC 99% Bandwidth EIRP Limit (dBm)		FCC 26dB Bandwidth Power Limit (dBm)		Note
					Ant 1	Ant 2	Ant 1	Ant 2	Ant 1	Ant 2	Ant 1	Ant 2	Ant 1	Ant 2	
11a	6Mbps	1	144	5720	18.25	18.25	19.60	19.60	-	-	-	-	-	-	
				NII-2C	14.15	14.15	16.40	16.40	22.51	22.51	28.51	28.51	23.15	23.15	
				NII-3	4.10	4.10	3.20	3.20	30.00	30.00	36.00	36.00	-	-	
HT20	MCS0	1	144	5720	19.15	19.05	20.44	20.44	-	-	-	-	-	-	
				NII-2C	14.55	14.55	16.60	16.60	22.63	22.63	28.63	28.63	23.20	23.20	
				NII-3	4.60	4.50	3.84	3.84	30.00	30.00	36.00	36.00	-	-	
HT40	MCS0	1	142	5710	36.80	36.80	38.76	38.94	-	-	-	-	-	-	
				NII-2C	33.40	33.40	35.52	35.70	23.98	23.98	30.00	30.00	23.98	23.98	
				NII-3	3.40	3.40	3.24	3.24	30.00	30.00	36.00	36.00	-	-	
VHT20	MCS0	1	144	5720	19.05	19.05	20.44	20.34	-	-	-	-	-	-	
				NII-2C	14.55	14.55	16.60	16.50	22.63	22.63	28.63	28.63	23.20	23.17	
				NII-3	4.50	4.50	3.84	3.84	30.00	30.00	36.00	36.00	-	-	
VHT40	MCS0	1	142	5710	36.80	36.80	38.85	38.86	-	-	-	-	-	-	
				NII-2C	33.40	33.40	35.61	35.70	23.98	23.98	30.00	30.00	23.98	23.98	
				NII-3	3.40	3.40	3.24	3.16	30.00	30.00	36.00	36.00	-	-	
VHT80	MCS0	1	138	5690	75.84	75.84	79.04	79.36	-	-	-	-	-	-	
				NII-2C	72.92	72.92	76.12	76.44	23.98	23.98	30.00	30.00	23.98	23.98	
				NII-3	2.92	2.92	2.92	2.92	30.00	30.00	36.00	36.00	-	-	
11a	6Mbps	2	144	5720	18.40	18.45	19.65	19.45	-	-	-	-	-	-	
				NII-2C	14.15	14.15	16.45	16.25	22.51	22.51	28.51	28.51	23.11	23.11	
				NII-3	4.25	4.3	3.2	3.2	30.00	30.00	36.00	36.00	30.00	30.00	
HT20	MCS0	2	144	5720	19.00	19.05	20.49	20.29	-	-	-	-	-	-	
				NII-2C	14.55	14.55	16.65	16.45	22.63	22.63	28.63	28.63	23.16	23.16	
				NII-3	4.45	4.5	3.84	3.84	30.00	30.00	36.00	36.00	30.00	30.00	
HT40	MCS0	2	142	5710	36.80	36.80	38.67	38.85	-	-	-	-	-	-	
				NII-2C	33.4	33.4	35.43	35.61	23.98	23.98	30.00	30.00	23.98	23.98	
				NII-3	3.4	3.4	3.24	3.24	30.00	30.00	36.00	36.00	30.00	30.00	
VHT20	MCS0	2	144	5720	19.05	19.05	20.54	20.44	-	-	-	-	-	-	
				NII-2C	14.55	14.55	16.7	16.6	22.63	22.63	28.63	28.63	23.20	23.20	
				NII-3	4.5	4.5	3.84	3.84	30.00	30.00	36.00	36.00	30.00	30.00	
VHT40	MCS0	2	142	5710	36.80	36.80	38.67	38.67	-	-	-	-	-	-	
				NII-2C	33.4	33.4	35.43	35.43	23.98	23.98	30.00	30.00	23.98	23.98	
				NII-3	3.4	3.4	3.24	3.24	30.00	30.00	36.00	36.00	30.00	30.00	
VHT80	MCS0	2	138	5690	75.84	75.84	79.20	78.72	-	-	-	-	-	-	
				NII-2C	72.92	72.92	76.28	75.8	23.98	23.98	30.00	30.00	23.98	23.98	
				NII-3	2.92	2.92	2.92	2.92	30.00	30.00	36.00	36.00	30.00	30.00	

TEST RESULTS DATA
Average Power Table

FCC Straddle Channel														
Mod.	Data Rate	NTX	CH.	Freq. (MHz)	Duty Factor (dB)		Average Conducted Power (dBm)			FCC Conducted Power Limit (dBm)		DG (dBi)		Pass/Fail
					Ant 1	Ant 2	Ant 1	Ant 2	SUM	Ant 1	Ant 2	Ant 1	Ant 2	
11a	6Mbps	1	144	5720	0.33	0.33	10.27	12.65		-	-	1.60	0.90	-
				NII-2C	0.33	0.33	9.30	11.78		23.15	23.15	1.60	0.90	Pass
				NII-3	0.33	0.33	3.27	5.24		-	-	1.60	0.90	Pass
HT20	MCS0	1	144	5720	0.31	0.31	10.22	12.57		-	-	1.60	0.90	-
				NII-2C	0.31	0.31	9.17	11.49		23.20	23.20	1.60	0.90	Pass
				NII-3	0.31	0.31	3.56	6.00		-	-	1.60	0.90	Pass
HT40	MCS0	1	142	5710	0.61	0.61	10.07	12.60		-	-	1.60	0.90	-
				NII-2C	0.61	0.61	9.70	12.23		23.98	23.98	1.60	0.90	Pass
				NII-3	0.61	0.61	-0.82	1.70		-	-	1.60	0.90	Pass
VHT20	MCS0	1	144	5720	0.31	0.31	10.43	12.75		-	-	1.60	0.90	-
				NII-2C	0.31	0.31	9.36	11.71		23.20	23.17	1.60	0.90	Pass
				NII-3	0.31	0.31	3.82	6.02		-	-	1.60	0.90	Pass
VHT40	MCS0	1	142	5710	0.66	0.63	10.20	12.76		-	-	1.60	0.90	-
				NII-2C	0.66	0.63	9.83	12.40		23.98	23.98	1.60	0.90	Pass
				NII-3	0.66	0.63	-0.71	1.82		-	-	1.60	0.90	Pass
VHT80	MCS0	1	138	5690	1.14	1.16	9.67	12.14		-	-	1.60	0.90	-
				NII-2C	1.14	1.16	9.52	12.00		23.98	23.98	1.60	0.90	Pass
				NII-3	1.14	1.16	-4.99	-2.87		-	-	1.60	0.90	Pass
11a	6Mbps	2	144	5720	0.33	0.33	10.54	9.91	13.25		-	-	1.60	-
				NII-2C	0.33	0.33	9.60	8.96	12.30		23.11	-	1.60	Pass
				NII-3	0.33	0.33	3.43	2.83	6.15		30.00	-	1.60	Pass
HT20	MCS0	2	144	5720	0.31	0.35	10.60	9.93	13.29		-	-	1.60	-
				NII-2C	0.31	0.35	9.57	8.90	12.26		23.16	-	1.60	Pass
				NII-3	0.31	0.35	3.86	3.19	6.55		30.00	-	1.60	Pass
HT40	MCS0	2	142	5710	0.68	0.64	10.44	9.95	13.21		-	-	1.60	-
				NII-2C	0.68	0.64	10.07	9.59	12.85		23.98	-	1.60	Pass
				NII-3	0.68	0.64	-0.43	-1.00	2.30		30.00	-	1.60	Pass
VHT20	MCS0	2	144	5720	0.35	0.35	10.86	9.96	13.44		-	-	1.60	-
				NII-2C	0.35	0.35	9.84	8.90	12.41		23.20	-	1.60	Pass
				NII-3	0.35	0.35	4.05	3.32	6.71		30.00	-	1.60	Pass
VHT40	MCS0	2	142	5710	0.63	0.63	10.55	9.97	13.28		-	-	1.60	-
				NII-2C	0.63	0.63	10.17	9.62	12.91		23.98	-	1.60	Pass
				NII-3	0.63	0.63	-0.25	-1.16	2.33		30.00	-	1.60	Pass
VHT80	MCS0	2	138	5690	1.20	1.14	10.03	9.24	12.66		-	-	1.60	-
				NII-2C	1.20	1.14	9.88	9.10	12.52		23.98	-	1.60	Pass
				NII-3	1.20	1.14	-4.61	-5.76	-2.14		30.00	-	1.60	Pass

TEST RESULTS DATA
Power Spectral Density

Straddle Channel														
Mod.	Data Rate	NTX	CH.	Freq. (MHz)	Duty Factor (dB)		Average Power Density (dBm/MHz)			Average PSD Limit (dBm/MHz)		DG (dBi)		Pass /Fail
					Ant 1	Ant 2	Ant 1	Ant 2	SUM	Ant 1	Ant 2	Ant 1	Ant 2	
11a	6Mbps	1	144	NII-2C	0.33	0.33	-1.55	0.79		11.00	11.00	1.60	0.90	Pass
				NII-3	0.33	0.33	-1.55	0.79		30.00	30.00	1.60	0.90	Pass
HT20	MCS0	1	144	NII-2C	0.31	0.31	-1.59	0.74		11.00	11.00	1.60	0.90	Pass
				NII-3	0.31	0.31	-1.59	0.74		30.00	30.00	1.60	0.90	Pass
HT40	MCS0	1	142	NII-2C	0.61	0.61	-4.70	-2.17		11.00	11.00	1.60	0.90	Pass
				NII-3	0.61	0.61	-4.70	-2.17		30.00	30.00	1.60	0.90	Pass
VHT20	MCS0	1	144	NII-2C	0.31	0.31	-1.59	0.71		11.00	11.00	1.60	0.90	Pass
				NII-3	0.31	0.31	-1.59	0.71		30.00	30.00	1.60	0.90	Pass
VHT40	MCS0	1	142	NII-2C	0.66	0.63	0.61	-1.96		11.00	11.00	1.60	0.90	Pass
				NII-3	0.66	0.63	0.61	-1.96		30.00	30.00	1.60	0.90	Pass
VHT80	MCS0	1	138	NII-2C	1.14	1.16	-8.08	-5.49		11.00	11.00	1.60	0.90	Pass
				NII-3	1.14	1.16	-8.08	-5.49		30.00	30.00	1.60	0.90	Pass
11a	6Mbps	2	144	NII-2C	0.33	0.33			1.67	11.00	4.27		Pass	
				NII-3	0.33	0.33			1.67	30.00	4.27		Pass	
HT20	MCS0	2	144	NII-2C	0.31	0.35			1.41	11.00	4.27		Pass	
				NII-3	0.31	0.35			1.41	30.00	4.27		Pass	
HT40	MCS0	2	142	NII-2C	0.68	0.64			1.54	11.00	4.27		Pass	
				NII-3	0.68	0.64			1.54	30.00	4.27		Pass	
VHT20	MCS0	2	144	NII-2C	0.35	0.35			1.48	11.00	4.27		Pass	
				NII-3	0.35	0.35			1.48	30.00	4.27		Pass	
VHT40	MCS0	2	142	NII-2C	0.63	0.63			-1.65	11.00	4.27		Pass	
				NII-3	0.63	0.63			-1.65	30.00	4.27		Pass	
VHT80	MCS0	2	138	NII-2C	1.20	1.14			-5.22	11.00	4.27		Pass	
				NII-3	1.20	1.14			-5.22	30.00	4.27		Pass	

TEST RESULTS DATA
Frequency Stability

Band I										
Mod.	Data Rate	NTX	CH.	Freq. (MHz)	Center Frequency (MHz)	Frequency Deviation (MHz)	Frequency Stability (ppm)	Temperature (°C)	Voltage (V)	Note
11a	6Mbps	1	36	5180	5180.050	0.050	9.65	20	3.5	
11a	6Mbps	1	36	5180	5180.000	0.000	0.00	20	4.35	
11a	6Mbps	1	36	5180	5180.000	0.000	0.00	20	3.8	
11a	6Mbps	1	36	5180	5180.000	0.000	0.00	-30	3.8	
11a	6Mbps	1	36	5180	5180.000	0.000	0.00	50	3.8	

Band II										
Mod.	Data Rate	NTX	CH.	Freq. (MHz)	Center Frequency (MHz)	Frequency Deviation (MHz)	Frequency Stability (ppm)	Temperature (°C)	Voltage (V)	Note
11a	6Mbps	1	64	5320	5320.050	0.050	9.40	20	3.5	
11a	6Mbps	1	64	5320	5320.000	0.000	0.00	20	4.35	
11a	6Mbps	1	64	5320	5320.050	0.050	9.40	20	3.8	
11a	6Mbps	1	64	5320	5320.050	0.050	9.40	-30	3.8	
11a	6Mbps	1	64	5320	5320.050	0.050	9.40	50	3.8	

Band III										
Mod.	Data Rate	NTX	CH.	Freq. (MHz)	Center Frequency (MHz)	Frequency Deviation (MHz)	Frequency Stability (ppm)	Temperature (°C)	Voltage (V)	Note
11a	6Mbps	1	100	5500	5500.000	0.000	0.00	20	3.5	
11a	6Mbps	1	100	5500	5500.050	0.050	9.09	20	4.35	
11a	6Mbps	1	100	5500	5500.050	0.050	9.09	20	3.8	
11a	6Mbps	1	100	5500	5500.050	0.050	9.09	-30	3.8	
11a	6Mbps	1	100	5500	5500.000	0.000	0.00	50	3.8	



<TXBF Modes>

Test Engineer:	Luffy Lin, Tommy Lee, and An Wu	Temperature:	21~25	°C
Test Date:	2016/06/20 ~ 2016/07/21	Relative Humidity:	51~54	%

TEST RESULTS DATA
26dB and 99% OBW

Band I													
Mod.	Data Rate	NTX	CH.	Freq. (MHz)	99% Bandwidth (MHz)		26 dB Bandwidth (MHz)		IC 99% Bandwidth Power Limit (dBm)		IC 99% Bandwidth EIRP Limit (dBm)		Note
					Ant 1	Ant 2	Ant 1	Ant 2	Ant 1	Ant 2	Ant 1	Ant 2	
11a	6Mbps	2	36	5180	18.80	19.05	20.70	23.00	-	-	22.74		
11a	6Mbps	2	44	5220	18.80	18.85	22.70	23.00	-	-	22.74		
11a	6Mbps	2	48	5240	18.05	18.10	20.60	20.70	-	-	22.56		
HT20	MCS0	2	36	5180	19.00	18.85	22.90	23.00	-	-	22.75		
HT20	MCS0	2	44	5220	18.55	18.90	23.30	23.10	-	-	22.68		
HT20	MCS0	2	48	5240	18.05	18.05	20.80	20.60	-	-	22.56		
HT40	MCS0	2	38	5190	36.60	36.70	40.68	40.32	-	-	23.01		
HT40	MCS0	2	46	5230	36.70	36.90	40.32	40.32	-	-	23.01		
VHT20	MCS0	2	36	5180	19.00	19.00	23.30	23.50	-	-	22.79		
VHT20	MCS0	2	44	5220	19.00	19.00	23.30	23.00	-	-	22.79		
VHT20	MCS0	2	48	5240	18.05	18.05	20.80	20.70	-	-	22.56		
VHT40	MCS0	2	38	5190	36.70	36.80	40.50	40.86	-	-	23.01		
VHT40	MCS0	2	46	5230	36.90	36.90	41.22	40.68	-	-	23.01		
VHT80	MCS0	2	42	5210	76.08	76.32	81.28	80.32	-	-	23.01		

TEST RESULTS DATA
Average Power Table

FCC Band I												
Mod.	Data Rate	NTX	CH.	Freq. (MHz)	Average Conducted Power (dBm)			FCC Conducted Power Limit (dBm)		DG (dBi)		Pass/Fail
					Ant 1	Ant 2	SUM	Ant 1	Ant 2	Ant 1	Ant 2	
11a	6Mbps	2	36	5180	11.70	11.20	14.47	24.00		4.21	Pass	
11a	6Mbps	2	44	5220	11.40	11.50	14.46	24.00		4.21	Pass	
11a	6Mbps	2	48	5240	11.60	11.10	14.37	24.00		4.21	Pass	
HT20	MCS0	2	36	5180	11.50	10.80	14.17	24.00		4.21	Pass	
HT20	MCS0	2	44	5220	11.50	11.10	14.31	24.00		4.21	Pass	
HT20	MCS0	2	48	5240	11.70	10.60	14.20	24.00		4.21	Pass	
HT40	MCS0	2	38	5190	9.70	9.30	12.51	24.00		4.21	Pass	
HT40	MCS0	2	46	5230	11.40	11.00	14.21	24.00		4.21	Pass	
VHT20	MCS0	2	36	5180	11.90	11.00	14.48	24.00		4.21	Pass	
VHT20	MCS0	2	44	5220	11.50	11.40	14.46	24.00		4.21	Pass	
VHT20	MCS0	2	48	5240	11.50	11.30	14.41	24.00		4.21	Pass	
VHT40	MCS0	2	38	5190	9.80	9.40	12.61	24.00		4.21	Pass	
VHT40	MCS0	2	46	5230	11.80	11.10	14.47	24.00		4.21	Pass	
VHT80	MCS0	2	42	5210	12.00	10.60	14.37	24.00		4.21	Pass	

TEST RESULTS DATA
Power Spectral Density

FCC Band I												
Mod.	Data Rate	NTX	CH.	Freq. (MHz)	Average Power Density (dBm/MHz)			Average PSD Limit (dBm/MHz)		DG (dBi)		Pass /Fail
					Ant 1	Ant 2	SUM	Ant 1	Ant 2	Ant 1	Ant 2	
11a	6Mbps	2	36	5180			2.97	11.00	4.21		Pass	
11a	6Mbps	2	44	5220			2.69	11.00	4.21		Pass	
11a	6Mbps	2	48	5240			2.87	11.00	4.21		Pass	
HT20	MCS0	2	36	5180			3.97	11.00	4.21		Pass	
HT20	MCS0	2	44	5220			3.80	11.00	4.21		Pass	
HT20	MCS0	2	48	5240			3.53	11.00	4.21		Pass	
HT40	MCS0	2	38	5190			1.52	11.00	4.21		Pass	
HT40	MCS0	2	46	5230			2.95	11.00	4.21		Pass	
VHT20	MCS0	2	36	5180			4.68	11.00	4.21		Pass	
VHT20	MCS0	2	44	5220			4.04	11.00	4.21		Pass	
VHT20	MCS0	2	48	5240			3.64	11.00	4.21		Pass	
VHT40	MCS0	2	38	5190			1.22	11.00	4.21		Pass	
VHT40	MCS0	2	46	5230			2.93	11.00	4.21		Pass	
VHT80	MCS0	2	42	5210			1.34	11.00	4.21		Pass	

TEST RESULTS DATA
26dB and 99% OBW

Band II															
Mod.	Data Rate	NTX	CH.	Freq. (MHz)	99% Bandwidth (MHz)		26 dB Bandwidth (MHz)		IC 99% Bandwidth Power Limit (dBm)		IC 99% Bandwidth EIRP Limit (dBm)		FCC 26dB Bandwidth Power Limit (dBm)		Note
					Ant 1	Ant 2	Ant 1	Ant 2	Ant 1	Ant 2	Ant 1	Ant 2	Ant 1	Ant 2	
11a	6Mbps	2	52	5260	18.05	18.05	20.50	20.70	23.56		29.56		23.98		
11a	6Mbps	2	60	5300	18.75	18.80	22.90	22.80	23.73		29.73		23.98		
11a	6Mbps	2	64	5320	18.75	18.65	23.00	22.80	23.71		29.71		23.98		
HT20	MCS0	2	52	5260	18.05	18.00	20.60	20.70	23.55		29.55		23.98		
HT20	MCS0	2	60	5300	18.85	18.80	22.90	23.20	23.74		29.74		23.98		
HT20	MCS0	2	64	5320	18.85	18.90	22.90	22.80	23.75		29.75		23.98		
HT40	MCS0	2	54	5270	36.60	36.80	41.04	40.32	23.98		30.00		23.98		
HT40	MCS0	2	62	5310	36.80	36.80	40.32	40.50	23.98		30.00		23.98		
VHT20	MCS0	2	52	5260	18.05	18.05	20.80	20.80	23.56		29.56		23.98		
VHT20	MCS0	2	60	5300	19.00	19.00	23.30	23.30	23.79		29.79		23.98		
VHT20	MCS0	2	64	5320	19.00	19.10	23.20	23.00	23.79		29.79		23.98		
VHT40	MCS0	2	54	5270	36.70	36.70	41.22	40.68	23.98		30.00		23.98		
VHT40	MCS0	2	62	5310	36.70	36.70	41.04	40.50	23.98		30.00		23.98		
VHT80	MCS0	2	58	5290	76.20	76.08	80.64	81.60	23.98		30.00		23.98		

TEST RESULTS DATA
Average Power Table

FCC Band II													
Mod.	Data Rate	NTX	CH.	Freq. (MHz)	Average Conducted Power (dBm)			FCC Conducted Power Limit (dBm)		DG (dBi)		EIRP Power Limit (dBm)	Pass/Fail
					Ant 1	Ant 2	SUM	Ant 1	Ant 2	Ant 1	Ant 2		
11a	6Mbps	2	52	5260	11.40	11.40	14.41	23.98		4.21	26.99	Pass	
11a	6Mbps	2	60	5300	11.40	11.30	14.36	23.98		4.21	26.99	Pass	
11a	6Mbps	2	64	5320	11.60	11.10	14.37	23.98		4.21	26.99	Pass	
HT20	MCS0	2	52	5260	11.50	11.20	14.36	23.98		4.21	26.99	Pass	
HT20	MCS0	2	60	5300	11.30	11.10	14.21	23.98		4.21	26.99	Pass	
HT20	MCS0	2	64	5320	11.70	10.90	14.33	23.98		4.21	26.99	Pass	
HT40	MCS0	2	54	5270	11.50	11.10	14.31	23.98		4.21	26.99	Pass	
HT40	MCS0	2	62	5310	11.40	11.30	14.36	23.98		4.21	26.99	Pass	
VHT20	MCS0	2	52	5260	11.50	11.40	14.46	23.98		4.21	26.99	Pass	
VHT20	MCS0	2	60	5300	11.40	11.40	14.41	23.98		4.21	26.99	Pass	
VHT20	MCS0	2	64	5320	11.30	11.40	14.36	23.98		4.21	26.99	Pass	
VHT40	MCS0	2	54	5270	11.60	11.30	14.46	23.98		4.21	26.99	Pass	
VHT40	MCS0	2	62	5310	11.50	11.30	14.41	23.98		4.21	26.99	Pass	
VHT80	MCS0	2	58	5290	12.00	10.80	14.45	23.98		4.21	26.99	Pass	

TEST RESULTS DATA
Power Spectral Density

Band II												
Mod.	Data Rate	NTX	CH.	Freq. (MHz)	Average Power Density (dBm/MHz)			Average PSD Limit (dBm/MHz)		DG (dBi)		Pass /Fail
					Ant 1	Ant 2	SUM	Ant 1	Ant 2	Ant 1	Ant 2	
11a	6Mbps	2	52	5260			2.82	11.00	4.21		Pass	
11a	6Mbps	2	60	5300			2.19	11.00	4.21		Pass	
11a	6Mbps	2	64	5320			2.41	11.00	4.21		Pass	
HT20	MCS0	2	52	5260			3.71	11.00	4.21		Pass	
HT20	MCS0	2	60	5300			3.17	11.00	4.21		Pass	
HT20	MCS0	2	64	5320			3.52	11.00	4.21		Pass	
HT40	MCS0	2	54	5270			2.35	11.00	4.21		Pass	
HT40	MCS0	2	62	5310			3.22	11.00	4.21		Pass	
VHT20	MCS0	2	52	5260			3.95	11.00	4.21		Pass	
VHT20	MCS0	2	60	5300			3.09	11.00	4.21		Pass	
VHT20	MCS0	2	64	5320			3.32	11.00	4.21		Pass	
VHT40	MCS0	2	54	5270			3.11	11.00	4.21		Pass	
VHT40	MCS0	2	62	5310			1.67	11.00	4.21		Pass	
VHT80	MCS0	2	58	5290			2.85	11.00	4.21		Pass	

TEST RESULTS DATA
26dB and 99% OBW

Band III															
Mod.	Data Rate	NTX	CH.	Freq. (MHz)	99% Bandwidth (MHz)		26 dB Bandwidth (MHz)		IC 99% Bandwidth Power Limit (dBm)		IC 99% Bandwidth EIRP Limit (dBm)		FCC 26dB Bandwidth Power Limit (dBm)		Note
					Ant 1	Ant 2	Ant 1	Ant 2	Ant 1	Ant 2	Ant 1	Ant 2	Ant 1	Ant 2	
11a	6Mbps	2	100	5500	18.85	18.70	23.10	22.80	23.72		29.72		23.98		
11a	6Mbps	2	116	5580	18.10	18.05	20.40	20.80	23.56		29.56		23.98		
11a	6Mbps	2	140	5700	18.65	18.65	23.20	23.00	23.71		29.71		23.98		
HT20	MCS0	2	100	5500	18.95	18.80	23.30	23.10	23.74		29.74		23.98		
HT20	MCS0	2	116	5580	18.00	18.10	20.80	20.80	23.55		29.55		23.98		
HT20	MCS0	2	140	5700	18.90	18.90	23.10	23.10	23.76		29.76		23.98		
HT40	MCS0	2	102	5510	36.70	36.80	40.50	41.94	23.98		30.00		23.98		
HT40	MCS0	2	110	5550	36.60	36.90	40.50	40.14	23.98		30.00		23.98		
HT40	MCS0	2	134	5670	36.60	36.80	40.50	40.32	23.98		30.00		23.98		
VHT20	MCS0	2	100	5500	18.85	19.05	23.10	23.20	23.75		29.75		23.98		
VHT20	MCS0	2	116	5580	18.05	18.05	20.70	20.90	23.56		29.56		23.98		
VHT20	MCS0	2	140	5700	19.10	18.90	23.00	23.00	23.76		29.76		23.98		
VHT40	MCS0	2	102	5510	36.80	36.70	41.04	41.04	23.98		30.00		23.98		
VHT40	MCS0	2	110	5550	36.70	36.70	40.86	40.68	23.98		30.00		23.98		
VHT40	MCS0	2	134	5670	36.80	36.90	40.68	45.50	23.98		30.00		23.98		
VHT80	MCS0	2	106	5530	76.44	75.96	81.28	81.92	23.98		30.00		23.98		
VHT80	MCS0	2	122	5610	75.96	75.96	80.00	80.00	23.98		30.00		23.98		

TEST RESULTS DATA
Average Power Table

FCC Band III													
Mod.	Data Rate	Nrx	CH.	Freq. (MHz)	Average Conducted Power (dBm)			FCC Conducted Power Limit (dBm)		DG (dBi)		EIRP Power Limit (dBm)	Pass/Fail
					Ant 1	Ant 2	SUM	Ant 1	Ant 2	Ant 1	Ant 2		
11a	6Mbps	2	100	5500	11.10	9.70	13.47	23.98		4.27	26.99	Pass	
11a	6Mbps	2	116	5580	10.90	9.40	13.22	23.98		4.27	26.99	Pass	
11a	6Mbps	2	140	5700	10.70	9.40	13.11	23.98		4.27	26.99	Pass	
HT20	MCS0	2	100	5500	11.00	9.50	13.32	23.98		4.27	26.99	Pass	
HT20	MCS0	2	116	5580	10.70	9.60	13.20	23.98		4.27	26.99	Pass	
HT20	MCS0	2	140	5700	10.90	9.90	13.44	23.98		4.27	26.99	Pass	
HT40	MCS0	2	102	5510	10.90	9.90	13.44	23.98		4.27	26.99	Pass	
HT40	MCS0	2	110	5550	10.80	9.90	13.38	23.98		4.27	26.99	Pass	
HT40	MCS0	2	134	5670	10.70	9.70	13.24	23.98		4.27	26.99	Pass	
VHT20	MCS0	2	100	5500	11.10	9.70	13.47	23.98		4.27	26.99	Pass	
VHT20	MCS0	2	116	5580	11.00	9.60	13.37	23.98		4.27	26.99	Pass	
VHT20	MCS0	2	140	5700	10.90	10.00	13.48	23.98		4.27	26.99	Pass	
VHT40	MCS0	2	102	5510	11.00	9.80	13.45	23.98		4.27	26.99	Pass	
VHT40	MCS0	2	110	5550	10.90	9.90	13.44	23.98		4.27	26.99	Pass	
VHT40	MCS0	2	134	5670	10.80	9.80	13.34	23.98		4.27	26.99	Pass	
VHT80	MCS0	2	106	5530	11.00	9.40	13.28	23.98		4.27	26.99	Pass	
VHT80	MCS0	2	122	5610	10.90	9.20	13.14	23.98		4.27	26.99	Pass	

TEST RESULTS DATA
Power Spectral Density

Band III												
Mod.	Data Rate	NTX	CH.	Freq. (MHz)	Average Power Density (dBm/MHz)			Average PSD Limit (dBm/MHz)		DG (dBi)		Pass /Fail
					Ant 1	Ant 2	SUM	Ant 1	Ant 2	Ant 1	Ant 2	
11a	6Mbps	2	100	5500			2.55	11.00	4.27		Pass	
11a	6Mbps	2	116	5580			3.08	11.00	4.27		Pass	
11a	6Mbps	2	140	5700			2.09	11.00	4.27		Pass	
HT20	MCS0	2	100	5500			3.42	11.00	4.27		Pass	
HT20	MCS0	2	116	5580			3.63	11.00	4.27		Pass	
HT20	MCS0	2	140	5700			2.94	11.00	4.27		Pass	
HT40	MCS0	2	102	5510			2.58	11.00	4.27		Pass	
HT40	MCS0	2	110	5550			3.10	11.00	4.27		Pass	
HT40	MCS0	2	134	5670			1.68	11.00	4.27		Pass	
VHT20	MCS0	2	100	5500			4.03	11.00	4.27		Pass	
VHT20	MCS0	2	116	5580			3.47	11.00	4.27		Pass	
VHT20	MCS0	2	140	5700			2.65	11.00	4.27		Pass	
VHT40	MCS0	2	102	5510			3.01	11.00	4.27		Pass	
VHT40	MCS0	2	110	5550			2.88	11.00	4.27		Pass	
VHT40	MCS0	2	134	5670			1.59	11.00	4.27		Pass	
VHT80	MCS0	2	106	5530			0.52	11.00	4.27		Pass	
VHT80	MCS0	2	122	5610			2.41	11.00	4.27		Pass	

TEST RESULTS DATA
26dB and 99% OBW

Straddle Channel															
Mod.	Data Rate	NTX	CH.	Freq. (MHz)	99% Bandwidth (MHz)		Emission Bandwidth (MHz)		IC 99% Bandwidth Power Limit (dBm)		IC 99% Bandwidth EIRP Limit (dBm)		FCC 26dB Bandwidth Power Limit (dBm)		Note
					Ant 1	Ant 2	Ant 1	Ant 2	Ant 1	Ant 2	Ant 1	Ant 2	Ant 1	Ant 2	
11a	6Mbps	2	144	5720	17.70	17.70	19.34	21.48	-	-	-	-	-	-	
				NII-2C	13.8	13.8	16.1	18.2	22.40	28.40	23.07				
				NII-3	3.9	3.9	3.24	3.28	30.00	36.00	30.00				
HT20	MCS0	2	144	5720	18.95	18.95	20.39	20.29	-	-	-	-	-		
				NII-2C	14.5	14.5	16.55	16.45	22.61	28.61	23.16				
				NII-3	4.45	4.45	3.84	3.84	30.00	36.00	30.00				
HT40	MCS0	2	142	5710	36.60	36.60	37.76	39.21	-	-	-	-	-		
				NII-2C	33.3	33.3	35.16	35.97	23.98	30.00	23.98				
				NII-3	3.3	3.3	2.6	3.24	30.00	36.00	30.00				
VHT20	MCS0	2	144	5720	18.95	18.95	20.59	20.24	-	-	-	-	-		
				NII-2C	14.5	14.5	16.75	16.4	22.61	28.61	23.15				
				NII-3	4.45	4.45	3.84	3.84	30.00	36.00	30.00				
VHT40	MCS0	2	142	5710	36.70	36.70	38.12	37.35	-	-	-	-	-		
				NII-2C	33.4	33.4	35.52	35.43	23.98	30.00	23.98				
				NII-3	3.3	3.3	2.6	1.92	30.00	36.00	30.00				
VHT80	MCS0	2	138	5690	76.32	76.32	75.20	75.32	-	-	-	-	-		
				NII-2C	73.4	73.4	75.16	75.32	23.98	30.00	23.98				
				NII-3	2.92	2.92	0.04	0	30.00	36.00	30.00				

TEST RESULTS DATA
Average Power Table

FCC Straddle Channel												
Mod.	Data Rate	NTX	CH.	Freq. (MHz)	Average Conducted Power (dBm)			FCC Conducted Power Limit (dBm)		DG (dBi)		Pass/Fail
					Ant 1	Ant 2	SUM	Ant 1	Ant 2	Ant 1	Ant 2	
11a	6Mbps	2	144	5720	9.67	10.66	13.20	-	-	4.21	-	-
				NII-2C	8.76	9.71	12.27	23.16	-	4.21	Pass	
				NII-3	2.44	3.59	6.06	30.00	-	4.21	Pass	
HT20	MCS0	2	144	5720	9.89	10.52	13.23	-	-	4.27	-	-
				NII-2C	8.92	9.53	12.25	23.16	-	4.27	Pass	
				NII-3	2.92	3.62	6.29	30.00	-	4.27	Pass	
HT40	MCS0	2	142	5710	9.79	10.84	13.36	-	-	4.27	-	-
				NII-2C	9.50	10.54	13.06	23.98	-	4.27	Pass	
				NII-3	-2.09	-0.86	1.58	30.00	-	4.27	Pass	
VHT20	MCS0	2	144	5720	10.09	10.68	13.41	-	-	4.27	-	-
				NII-2C	9.08	9.83	12.48	23.15	-	4.27	Pass	
				NII-3	3.26	3.18	6.23	30.00	-	4.27	Pass	
VHT40	MCS0	2	142	5710	9.93	10.88	13.44	-	-	4.27	-	-
				NII-2C	9.62	10.56	13.13	23.98	-	4.27	Pass	
				NII-3	-1.70	-0.58	1.91	30.00	-	4.27	Pass	
VHT80	MCS0	2	138	5690	10.39	9.97	13.20	-	-	4.27	-	-
				NII-2C	10.29	9.86	13.09	23.98	-	4.27	Pass	
				NII-3	-5.99	-5.99	-2.98	30.00	-	4.27	Pass	

TEST RESULTS DATA
Power Spectral Density

Straddle Channel												
Mod.	Data Rate	NTX	CH.	Freq. (MHz)	Average Power Density (dBm/MHz)			Average PSD Limit (dBm/MHz)		DG (dBi)		Pass /Fail
					Ant 1	Ant 2	SUM	Ant 1	Ant 2	Ant 1	Ant 2	
HT20	MCS0	2	144	NII-2C				2.55	11.00	4.27		Pass
				NII-3				2.55	30.00	4.27		Pass
HT40	MCS0	2	142	NII-2C				2.28	11.00	4.27		Pass
				NII-3				2.28	30.00	4.27		Pass
VHT20	MCS0	2	144	NII-2C				2.31	11.00	4.27		Pass
				NII-3				2.31	30.00	4.27		Pass
VHT40	MCS0	2	142	NII-2C				1.35	11.00	4.27		Pass
				NII-3				1.35	30.00	4.27		Pass
VHT80	MCS0	2	138	NII-2C				1.05	11.00	4.27		Pass
				NII-3				1.05	30.00	4.27		Pass



Appendix B. Radiated Spurious Emission

Test Engineer :	Jesse Wang, James Chiu, Derek Hsu, and Luke Chang	Temperature :	21~24°C
		Relative Humidity :	54~55%

<CDD Mode>

Band 3 - 5470~5725MHz

WIFI 802.11a (Band Edge @ 3m)

WIFI Ant. 2	Note	Frequency (MHz)	Level (dBμV/m)	Over Limit (dB)	Limit Line (dBμV/m)	Read Level (dBμV)	Antenna Factor (dB/m)	Cable Loss (dB)	Preamp Factor (dB)	Ant Pos (cm)	Table Pos (deg)	Peak Avg. (P/A)	Pol. (H/V)	
802.11a CH 100 5500MHz		5468.88	50.15	-23.85	74	38.08	35.42	11.89	35.24	300	108	P	H	
		5469.2	42.18	-11.82	54	30.11	35.42	11.89	35.24	300	108	A	H	
	*	5500	98.96	-	-	86.81	35.5	11.89	35.24	300	108	P	H	
	*	5500	90.75	-	-	78.6	35.5	11.89	35.24	300	108	A	H	
													H	
														H
			5465.84	52.47	-21.53	74	40.4	35.42	11.89	35.24	200	214	P	V
			5469.84	44.95	-9.05	54	32.88	35.42	11.89	35.24	200	214	A	V
	*		5500	105.79	-	-	93.64	35.5	11.89	35.24	200	214	P	V
	*		5500	97.77	-	-	85.62	35.5	11.89	35.24	200	214	A	V
														V
														V
802.11a CH 116 5580MHz		5354.32	49.5	-24.5	74	37.83	35.14	11.76	35.23	323	106	P	H	
		5467.36	41.68	-12.32	54	29.61	35.42	11.89	35.24	323	106	A	H	
	*	5580	96.88	-	-	84.74	35.51	11.89	35.26	323	106	P	H	
	*	5580	89.45	-	-	77.31	35.51	11.89	35.26	323	106	A	H	
			5733.33	51.45	-22.55	74	39.14	35.54	12.06	35.29	323	106	P	H
			5728.78	42.14	-11.86	54	29.83	35.54	12.06	35.29	323	106	A	H
			5403.28	49.91	-24.09	74	37.99	35.26	11.89	35.23	234	225	P	V
			5465.2	41.91	-12.09	54	29.84	35.42	11.89	35.24	234	225	A	V
	*		5580	105.04	-	-	92.9	35.51	11.89	35.26	234	225	P	V
	*		5580	97.62	-	-	85.48	35.51	11.89	35.26	234	225	A	V
			5745.93	51.07	-22.93	74	38.7	35.55	12.11	35.29	234	225	P	V
			5735.6	42.62	-11.38	54	30.3	35.55	12.06	35.29	234	225	A	V



802.11a CH 140 5700MHz	*	5700	95.98	-	-	83.72	35.54	12	35.28	100	164	P	H
	*	5700	89.3	-	-	77.04	35.54	12	35.28	100	164	A	H
		5742.92	51.45	-22.55	74	39.08	35.55	12.11	35.29	100	164	P	H
		5755.32	42.34	-11.66	54	29.97	35.55	12.11	35.29	100	164	A	H
													H
													H
	*	5700	104.95	-	-	92.69	35.54	12	35.28	226	225	P	V
	*	5700	97.48	-	-	85.22	35.54	12	35.28	226	225	A	V
		5734.04	54.74	-19.26	74	42.43	35.54	12.06	35.29	226	225	P	V
		5725.72	44.52	-9.48	54	32.21	35.54	12.06	35.29	226	225	A	V
													V
													V
Remark	1. No other spurious found. 2. All results are PASS against Peak and Average limit line.												



Band 3 - 5470~5725MHz
WIFI 802.11a (Harmonic @ 3m)

WIFI	Note	Frequency	Level	Over	Limit	Read	Antenna	Cable	Preamp	Ant	Table	Peak	Pol.
Ant.				Limit	Line	Level	Factor	Loss	Factor	Pos	Pos	Avg.	
2		(MHz)	(dBμV/m)	(dB)	(dBμV/m)	(dBμV)	(dB/m)	(dB)	(dB)	(cm)	(deg)	(P/A)	(H/V)
802.11a CH 100 5500MHz		11000	45	-29	74	48.33	37.9	17.17	58.4	100	0	P	H
		16500	45.22	-28.78	74	39.49	41.6	20.23	56.1	100	0	P	H
													H
													H
		11000	44.04	-29.96	74	47.37	37.9	17.17	58.4	100	0	P	V
		16500	46.44	-27.56	74	40.71	41.6	20.23	56.1	100	0	P	V
													V
													V
802.11a CH 116 5580MHz		11160	42.97	-31.03	74	45.77	38.07	17.16	58.03	100	0	P	H
		16740	44.92	-29.08	74	38.6	41.89	20.39	55.96	100	0	P	H
													H
													H
		11160	43.08	-30.92	74	45.88	38.07	17.16	58.03	100	0	P	V
		16740	44.5	-29.5	74	38.18	41.89	20.39	55.96	100	0	P	V
													V
													V
802.11a CH 140 5700MHz		11400	42.8	-31.2	74	44.86	38.3	17.16	57.52	100	0	P	H
		17100	47.71	-26.29	74	40.76	42.14	20.65	55.84	100	0	P	H
													H
													H
		11400	42.64	-31.36	74	44.7	38.3	17.16	57.52	100	0	P	V
		17100	46.56	-27.44	74	39.61	42.14	20.65	55.84	100	0	P	V
													V
													V
Remark	1. No other spurious found. 2. All results are PASS against Peak and Average limit line.												



Band 3 - 5470~5725MHz
WIFI 802.11ac VHT20 (Band Edge @ 3m)

WIFI	Note	Frequency	Level	Over	Limit	Read	Antenna	Cable	Preamp	Ant	Table	Peak	Pol.	
Ant.				Limit	Line	Level	Factor	Loss	Factor	Pos	Pos	Avg.		
2		(MHz)	(dBμV/m)	(dB)	(dBμV/m)	(dBμV)	(dB/m)	(dB)	(dB)	(cm)	(deg)	(P/A)	(H/V)	
802.11ac VHT20 CH 100 5500MHz		5406.48	50.02	-23.98	74	38.1	35.26	11.89	35.23	100	209	P	H	
		5465.84	42.13	-11.87	54	30.06	35.42	11.89	35.24	100	209	A	H	
	*	5500	97.02	-	-	84.87	35.5	11.89	35.24	100	209	P	H	
	*	5500	89.14	-	-	76.99	35.5	11.89	35.24	100	209	A	H	
													H	
														H
			5468.4	51.91	-22.09	74	39.84	35.42	11.89	35.24	301	198	P	V
			5470	44.57	-9.43	54	32.5	35.42	11.89	35.24	301	198	A	V
	*		5500	103.81	-	-	91.66	35.5	11.89	35.24	301	198	P	V
	*		5500	96.27	-	-	84.12	35.5	11.89	35.24	301	198	A	V
														V
														V
802.11ac VHT20 CH 116 5580MHz		5442.16	49.65	-24.35	74	37.66	35.34	11.89	35.24	100	208	P	H	
		5463.28	41.65	-12.35	54	29.58	35.42	11.89	35.24	100	208	A	H	
	*	5580	96.19	-	-	84.05	35.51	11.89	35.26	100	208	P	H	
	*	5580	88.62	-	-	76.48	35.51	11.89	35.26	100	208	A	H	
			5748.2	51.28	-22.72	74	38.91	35.55	12.11	35.29	100	208	P	H
			5762.9	42.11	-11.89	54	29.74	35.55	12.11	35.29	100	208	A	H
			5467.12	50.03	-23.97	74	37.96	35.42	11.89	35.24	289	202	P	V
			5469.04	41.79	-12.21	54	29.72	35.42	11.89	35.24	289	202	A	V
	*		5580	105.6	-	-	93.46	35.51	11.89	35.26	289	202	P	V
	*		5580	97.26	-	-	85.12	35.51	11.89	35.26	289	202	A	V
			5731.4	50.74	-23.26	74	38.43	35.54	12.06	35.29	289	202	P	V
			5732.98	42.4	-11.6	54	30.09	35.54	12.06	35.29	289	202	A	V



802.11ac VHT20 CH 140 5700MHz	*	5700	97.01	-	-	84.75	35.54	12	35.28	100	164	P	H
	*	5700	89.44	-	-	77.18	35.54	12	35.28	100	164	A	H
		5730.04	50.89	-23.11	74	38.58	35.54	12.06	35.29	100	164	P	H
		5730.52	42.46	-11.54	54	30.15	35.54	12.06	35.29	100	164	A	H
													H
													H
	*	5700	105.02	-	-	92.76	35.54	12	35.28	226	226	P	V
	*	5700	97.41	-	-	85.15	35.54	12	35.28	226	226	A	V
		5730.12	54.93	-19.07	74	42.62	35.54	12.06	35.29	226	226	P	V
		5730.84	44.88	-9.12	54	32.57	35.54	12.06	35.29	226	226	A	V
												V	
												V	
Remark	1. No other spurious found. 2. All results are PASS against Peak and Average limit line.												



Band 3 - 5470~5725MHz
WIFI 802.11ac VHT20 (Harmonic @ 3m)

WIFI	Note	Frequency	Level	Over	Limit	Read	Antenna	Cable	Preamp	Ant	Table	Peak	Pol.
Ant.				Limit	Line	Level	Factor	Loss	Factor	Pos	Pos	Avg.	
2		(MHz)	(dBμV/m)	(dB)	(dBμV/m)	(dBμV)	(dB/m)	(dB)	(dB)	(cm)	(deg)	(P/A)	(H/V)
802.11ac VHT20 CH 100 5500MHz		11000	42.97	-31.03	74	46.3	37.9	17.17	58.4	100	0	P	H
		16500	45.21	-28.79	74	39.48	41.6	20.23	56.1	100	0	P	H
													H
													H
		11000	43.38	-30.62	74	46.71	37.9	17.17	58.4	100	0	P	V
		16500	45.4	-28.6	74	39.67	41.6	20.23	56.1	100	0	P	V
													V
802.11ac VHT20 CH 116 5580MHz		11160	43.5	-30.5	74	46.3	38.07	17.16	58.03	100	0	P	H
		16740	45.41	-28.59	74	39.09	41.89	20.39	55.96	100	0	P	H
													H
													H
		11160	42.7	-31.3	74	45.5	38.07	17.16	58.03	100	0	P	V
		16740	45.04	-28.96	74	38.72	41.89	20.39	55.96	100	0	P	V
													V
802.11ac VHT20 CH 140 5700MHz		11400	42.95	-31.05	74	45.01	38.3	17.16	57.52	100	0	P	H
		17100	46.37	-27.63	74	39.42	42.14	20.65	55.84	100	0	P	H
													H
													H
		11400	42.54	-31.46	74	44.6	38.3	17.16	57.52	100	0	P	V
		17100	47.17	-26.83	74	40.22	42.14	20.65	55.84	100	0	P	V
													V
Remark	1. No other spurious found.												
	2. All results are PASS against Peak and Average limit line.												



Band 3 - 5470~5725MHz
WIFI 802.11ac VHT40 (Band Edge @ 3m)

WIFI	Note	Frequency	Level	Over	Limit	Read	Antenna	Cable	Preamp	Ant	Table	Peak	Pol.
Ant.				Limit	Line	Level	Factor	Loss	Factor	Pos	Pos	Avg.	
2		(MHz)	(dBμV/m)	(dB)	(dBμV/m)	(dBμV)	(dB/m)	(dB)	(dB)	(cm)	(deg)	(P/A)	(H/V)
802.11ac VHT40 CH 102 5510MHz		5462.56	54.72	-19.28	74	42.65	35.42	11.89	35.24	103	210	P	H
		5470	46.11	-7.89	54	34.04	35.42	11.89	35.24	103	210	A	H
	*	5510	93.75	-	-	81.6	35.5	11.89	35.24	103	210	P	H
	*	5510	86.7	-	-	74.55	35.5	11.89	35.24	103	210	A	H
		5734.73	51.74	-22.26	74	39.42	35.55	12.06	35.29	103	210	P	H
		5730	42.3	-11.7	54	29.99	35.54	12.06	35.29	103	210	A	H
		5469.28	61.87	-12.13	74	49.8	35.42	11.89	35.24	298	200	P	V
		5469.76	52.58	-1.42	54	40.51	35.42	11.89	35.24	298	200	A	V
	*	5510	101.92	-	-	89.77	35.5	11.89	35.24	298	200	P	V
	*	5510	93.92	-	-	81.77	35.5	11.89	35.24	298	200	A	V
		5725.98	50.63	-23.37	74	38.32	35.54	12.06	35.29	298	200	P	V
		5739.63	42.37	-11.63	54	30.05	35.55	12.06	35.29	298	200	A	V
802.11ac VHT40 CH 110 5550MHz		5462.32	49.61	-24.39	74	37.58	35.38	11.89	35.24	104	209	P	H
		5467.36	42.15	-11.85	54	30.08	35.42	11.89	35.24	104	209	A	H
	*	5550	95.11	-	-	82.96	35.51	11.89	35.25	104	209	P	H
	*	5550	87.51	-	-	75.36	35.51	11.89	35.25	104	209	A	H
		5731.75	51.5	-22.5	74	39.19	35.54	12.06	35.29	104	209	P	H
		5736.3	42.2	-11.8	54	29.88	35.55	12.06	35.29	104	209	A	H
		5463.28	52.7	-21.3	74	40.63	35.42	11.89	35.24	248	228	P	V
		5469.28	44.04	-9.96	54	31.97	35.42	11.89	35.24	248	228	A	V
	*	5550	102.71	-	-	90.56	35.51	11.89	35.25	248	228	P	V
	*	5550	95.1	-	-	82.95	35.51	11.89	35.25	248	228	A	V
	5764.83	51.32	-22.68	74	38.95	35.55	12.11	35.29	248	228	P	V	
	5744.18	42.48	-11.52	54	30.11	35.55	12.11	35.29	248	228	A	V	



802.11ac VHT40 CH 134 5670MHz		5466.4	49.93	-24.07	74	37.86	35.42	11.89	35.24	100	12	P	H
		5464.96	42.2	-11.8	54	30.13	35.42	11.89	35.24	100	12	A	H
	*	5670	94.19	-	-	81.93	35.53	12	35.27	100	12	P	H
	*	5670	86.31	-	-	74.05	35.53	12	35.27	100	12	A	H
		5744.18	51.38	-22.62	74	39.01	35.55	12.11	35.29	100	12	P	H
		5725.8	42.61	-11.39	54	30.3	35.54	12.06	35.29	100	12	A	H
		5470	50.45	-23.55	74	38.38	35.42	11.89	35.24	297	202	P	V
		5469.28	42.04	-11.96	54	29.97	35.42	11.89	35.24	297	202	A	V
	*	5670	103.67	-	-	91.41	35.53	12	35.27	297	202	P	V
	*	5670	95.4	-	-	83.14	35.53	12	35.27	297	202	A	V
		5727.55	53.39	-20.61	74	41.08	35.54	12.06	35.29	297	202	P	V
	5727.9	44.82	-9.18	54	32.51	35.54	12.06	35.29	297	202	A	V	
Remark	1. No other spurious found. 2. All results are PASS against Peak and Average limit line.												



Band 3 - 5470~5725MHz
WIFI 802.11ac VHT40 (Harmonic @ 3m)

WIFI	Note	Frequency	Level	Over	Limit	Read	Antenna	Cable	Preamp	Ant	Table	Peak	Pol.
Ant.				Limit	Line	Level	Factor	Loss	Factor	Pos	Pos	Avg.	
2		(MHz)	(dBμV/m)	(dB)	(dBμV/m)	(dBμV)	(dB/m)	(dB)	(dB)	(cm)	(deg)	(P/A)	(H/V)
802.11ac VHT40 CH 102 5510MHz		11020	44.33	-29.67	74	47.6	37.92	17.17	58.36	100	0	P	H
		16530	45.26	-28.74	74	39.45	41.64	20.25	56.08	100	0	P	H
													H
													H
		11020	42.95	-31.05	74	46.22	37.92	17.17	58.36	100	0	P	V
		16530	45.36	-28.64	74	39.55	41.64	20.25	56.08	100	0	P	V
													V
802.11ac VHT40 CH 110 5550MHz		11100	43.57	-30.43	74	46.59	38	17.16	58.18	100	0	P	H
		16650	45.74	-28.26	74	39.62	41.79	20.34	56.01	100	0	P	H
													H
													H
		11100	42.57	-31.43	74	45.59	38	17.16	58.18	100	0	P	V
		16650	46.63	-27.37	74	40.51	41.79	20.34	56.01	100	0	P	V
													V
802.11ac VHT40 CH 134 5670MHz		11340	42.11	-31.89	74	44.39	38.23	17.16	57.67	100	0	P	H
		17010	45.77	-28.23	74	38.8	42.19	20.59	55.81	100	0	P	H
													H
													H
		11340	42.72	-31.28	74	45	38.23	17.16	57.67	100	0	P	V
		17010	46.41	-27.59	74	39.44	42.19	20.59	55.81	100	0	P	V
													V
Remark	1. No other spurious found.												
	2. All results are PASS against Peak and Average limit line.												



Band 3 5470~5725MHz
WIFI 802.11ac VHT80 (Band Edge @ 3m)

WIFI	Note	Frequency	Level	Over	Limit	Read	Antenna	Cable	Preamp	Ant	Table	Peak	Pol.
Ant.				Limit	Line	Level	Factor	Loss	Factor	Pos	Pos	Avg.	
2		(MHz)	(dBμV/m)	(dB)	(dBμV/m)	(dBμV)	(dB/m)	(dB)	(dB)	(cm)	(deg)	(P/A)	(H/V)
802.11ac VHT80 CH 106 5530MHz		5462.08	51.66	-22.34	74	39.63	35.38	11.89	35.24	103	208	P	H
		5467.12	45.6	-8.4	54	33.53	35.42	11.89	35.24	103	208	A	H
	*	5530	90.59	-	-	78.45	35.5	11.89	35.25	103	208	P	H
	*	5530	83	-	-	70.86	35.5	11.89	35.25	103	208	A	H
		5733.33	51.28	-22.72	74	38.97	35.54	12.06	35.29	103	208	P	H
		5749.25	43.21	-10.79	54	30.84	35.55	12.11	35.29	103	208	A	H
		5467.12	58.91	-15.09	74	46.84	35.42	11.89	35.24	235	228	P	V
		5461.36	50.36	-3.64	54	38.33	35.38	11.89	35.24	235	228	A	V
	*	5530	98.26	-	-	86.12	35.5	11.89	35.25	235	228	P	V
	*	5530	91.21	-	-	79.07	35.5	11.89	35.25	235	228	A	V
		5728.95	50.32	-23.68	74	38.01	35.54	12.06	35.29	235	228	P	V
		5744.35	43.35	-10.65	54	30.98	35.55	12.11	35.29	235	228	A	V
802.11ac VHT80 CH 122 5610MHz		5455.6	49.97	-24.03	74	37.94	35.38	11.89	35.24	100	267	P	H
		5437.36	43.11	-10.89	54	31.12	35.34	11.89	35.24	100	267	A	H
	*	5610	90.99	-	-	78.84	35.52	11.89	35.26	100	267	P	H
	*	5610	83.57	-	-	71.42	35.52	11.89	35.26	100	267	A	H
		5751.53	50.58	-23.42	74	38.21	35.55	12.11	35.29	100	267	P	H
		5746.63	43.82	-10.18	54	31.45	35.55	12.11	35.29	100	267	A	H
		5461.84	52.57	-21.43	74	40.54	35.38	11.89	35.24	300	204	P	V
		5466.16	45.72	-8.28	54	33.65	35.42	11.89	35.24	300	204	A	V
	*	5610	99.52	-	-	87.37	35.52	11.89	35.26	300	204	P	V
	*	5610	92.22	-	-	80.07	35.52	11.89	35.26	300	204	A	V
	5725.63	52.15	-21.85	74	39.84	35.54	12.06	35.29	300	204	P	V	
	5726.33	44.8	-9.2	54	32.49	35.54	12.06	35.29	300	204	A	V	
Remark	1. No other spurious found. 2. All results are PASS against Peak and Average limit line.												



Band 3 5470~5725MHz
WIFI 802.11ac VHT80 (Harmonic @ 3m)

WIFI	Note	Frequency	Level	Over	Limit	Read	Antenna	Cable	Preamp	Ant	Table	Peak	Pol.
Ant.				Limit	Line	Level	Factor	Loss	Factor	Pos	Pos	Avg.	
2		(MHz)	(dBμV/m)	(dB)	(dBμV/m)	(dBμV)	(dB/m)	(dB)	(dB)	(cm)	(deg)	(P/A)	(H/V)
802.11ac VHT80 CH 106 5530MHz		11060	43.54	-30.46	74	46.66	37.97	17.16	58.25	100	0	P	H
		16590	44.19	-29.81	74	38.23	41.7	20.31	56.05	100	0	P	H
													H
													H
		11060	43.82	-30.18	74	46.94	37.97	17.16	58.25	100	0	P	V
		16590	45.29	-28.71	74	39.33	41.7	20.31	56.05	100	0	P	V
802.11ac VHT80 CH 122 5610MHz		11220	42.4	-31.6	74	45.04	38.12	17.16	57.92	100	0	P	H
		16830	46.69	-27.31	74	40.12	41.99	20.48	55.9	100	0	P	H
													H
													H
		11220	42.4	-31.6	74	45.04	38.12	17.16	57.92	100	0	P	V
		16830	45.88	-28.12	74	39.31	41.99	20.48	55.9	100	0	P	V
Remark	1. No other spurious found.												
	2. All results are PASS against Peak and Average limit line.												



Band 3 - Straddle Channel
WIFI 802.11a (Band Edge @ 3m)

WIFI Ant. 2	Note	Frequency (MHz)	Level (dBμV/m)	Over Limit (dB)	Limit Line (dBμV/m)	Read Level (dBμV)	Antenna Factor (dB/m)	Cable Loss (dB)	Preamp Factor (dB)	Ant Pos (cm)	Table Pos (deg)	Peak Avg. (P/A)	Pol. (H/V)
802.11a CH 144 5720MHz	*	5720	96.58	-	-	84.26	35.54	12.06	35.28	100	10	P	H
	*	5720	88.84	-	-	76.52	35.54	12.06	35.28	100	10	A	H
													H
													H
													H
	*	5720	104.34	-	-	92.02	35.54	12.06	35.28	194	206	P	V
	*	5720	96.5	-	-	84.18	35.54	12.06	35.28	194	206	A	V
													V
													V
													V
													V
Remark	1. No other spurious found. 2. All results are PASS against Peak and Average limit line.												



Band 3 - Straddle Channel
WIFI 802.11a (Harmonic @ 3m)

WIFI	Note	Frequency	Level	Over	Limit	Read	Antenna	Cable	Preamp	Ant	Table	Peak	Pol.	
Ant.				Limit	Line	Level	Factor	Loss	Factor	Pos	Pos	Avg.		
2		(MHz)	(dBμV/m)	(dB)	(dBμV/m)	(dBμV)	(dB/m)	(dB)	(dB)	(cm)	(deg)	(P/A)	(H/V)	
802.11a CH 144 5720MHz		11440	43.41	-30.59	74	45.37	38.33	17.16	57.45	100	0	P	H	
		17160	46.12	-27.88	74	39.19	42.1	20.7	55.87	100	0	P	H	
													H	
													H	
			11440	43.34	-30.66	74	45.3	38.33	17.16	57.45	100	0	P	V
			17160	46.83	-27.17	74	39.9	42.1	20.7	55.87	100	0	P	V
														V
														V
Remark	1. No other spurious found. 2. All results are PASS against Peak and Average limit line.													



Band 3 - Straddle Channel
WIFI 802.11ac VHT20 (Band Edge @ 3m)

WIFI	Note	Frequency	Level	Over	Limit	Read	Antenna	Cable	Preamp	Ant	Table	Peak	Pol.
Ant.				Limit	Line	Level	Factor	Loss	Factor	Pos	Pos	Avg.	
2		(MHz)	(dBμV/m)	(dB)	(dBμV/m)	(dBμV)	(dB/m)	(dB)	(dB)	(cm)	(deg)	(P/A)	(H/V)
802.11ac VHT20 CH 144 5720MHz	*	5720	96.7	-	-	84.38	35.54	12.06	35.28	100	10	P	H
	*	5720	89.1	-	-	76.78	35.54	12.06	35.28	100	10	A	H
													H
													H
													H
													H
	*	5720	105.45	-	-	93.13	35.54	12.06	35.28	236	223	P	V
	*	5720	97.79	-	-	85.47	35.54	12.06	35.28	236	223	A	V
													V
													V
												V	
												V	
Remark	1. No other spurious found. 2. All results are PASS against Peak and Average limit line.												



Band 3 - Straddle Channel
WIFI 802.11ac VHT20 (Harmonic @ 3m)

WIFI	Note	Frequency	Level	Over	Limit	Read	Antenna	Cable	Preamp	Ant	Table	Peak	Pol.	
Ant.				Limit	Line	Level	Factor	Loss	Factor	Pos	Pos	Avg.		
2		(MHz)	(dBμV/m)	(dB)	(dBμV/m)	(dBμV)	(dB/m)	(dB)	(dB)	(cm)	(deg)	(P/A)	(H/V)	
802.11ac VHT20 CH 144 5720MHz		11440	42.29	-31.71	74	44.25	38.33	17.16	57.45	100	0	P	H	
		17160	46.34	-27.66	74	39.41	42.1	20.7	55.87	100	0	P	H	
													H	
													H	
			11440	42.23	-31.77	74	44.19	38.33	17.16	57.45	100	0	P	V
			17160	46.32	-27.68	74	39.39	42.1	20.7	55.87	100	0	P	V
														V
Remark	1. No other spurious found. 2. All results are PASS against Peak and Average limit line.													



Band 3 - Straddle Channel
WIFI 802.11ac VHT40 (Band Edge @ 3m)

WIFI	Note	Frequency	Level	Over	Limit	Read	Antenna	Cable	Preamp	Ant	Table	Peak	Pol.
Ant.				Limit	Line	Level	Factor	Loss	Factor	Pos	Pos	Avg.	
2		(MHz)	(dBμV/m)	(dB)	(dBμV/m)	(dBμV)	(dB/m)	(dB)	(dB)	(cm)	(deg)	(P/A)	(H/V)
802.11ac VHT40 CH 142 5710MHz	*	5710	94.94	-	-	82.62	35.54	12.06	35.28	100	163	P	H
	*	5710	87.2	-	-	74.88	35.54	12.06	35.28	100	163	A	H
													H
													H
													H
													H
	*	5710	103.26	-	-	90.94	35.54	12.06	35.28	236	224	P	V
	*	5710	95.45	-	-	83.13	35.54	12.06	35.28	236	224	A	V
													V
													V
												V	
												V	
Remark	1. No other spurious found. 2. All results are PASS against Peak and Average limit line.												



**Band 3 - Straddle Channel
WIFI 802.11ac VHT40 (Harmonic @ 3m)**

WIFI	Note	Frequency	Level	Over	Limit	Read	Antenna	Cable	Preamp	Ant	Table	Peak	Pol.	
Ant.				Limit	Line	Level	Factor	Loss	Factor	Pos	Pos	Avg.		
2		(MHz)	(dBμV/m)	(dB)	(dBμV/m)	(dBμV)	(dB/m)	(dB)	(dB)	(cm)	(deg)	(P/A)	(H/V)	
802.11ac VHT40 CH 142 5710MHz		11420	43.16	-30.84	74	45.16	38.32	17.16	57.48	100	0	P	H	
		17130	46.94	-27.06	74	40	42.12	20.67	55.85	100	0	P	H	
													H	
													H	
			11420	43.51	-30.49	74	45.51	38.32	17.16	57.48	100	0	P	V
			17130	46.07	-27.93	74	39.13	42.12	20.67	55.85	100	0	P	V
														V
Remark	1. No other spurious found. 2. All results are PASS against Peak and Average limit line.													



Band 3 - Straddle Channel
WIFI 802.11ac VHT80 (Band Edge @ 3m)

WIFI	Note	Frequency	Level	Over	Limit	Read	Antenna	Cable	Preamp	Ant	Table	Peak	Pol.
Ant.				Limit	Line	Level	Factor	Loss	Factor	Pos	Pos	Avg.	
2		(MHz)	(dBμV/m)	(dB)	(dBμV/m)	(dBμV)	(dB/m)	(dB)	(dB)	(cm)	(deg)	(P/A)	(H/V)
802.11ac VHT80 CH 138 5690MHz	*	5690	91.51	-	-	79.25	35.54	12	35.28	100	12	P	H
	*	5690	83.77	-	-	71.51	35.54	12	35.28	100	12	A	H
													H
													H
													H
													H
	*	5690	99.48	-	-	87.22	35.54	12	35.28	297	202	P	V
	*	5690	91.96	-	-	79.7	35.54	12	35.28	297	202	A	V
													V
													V
												V	
												V	
Remark	1. No other spurious found. 2. All results are PASS against Peak and Average limit line.												



**Band 3 - Straddle Channel
WIFI 802.11ac VHT80 (Harmonic @ 3m)**

WIFI	Note	Frequency	Level	Over	Limit	Read	Antenna	Cable	Preamp	Ant	Table	Peak	Pol.	
Ant.				Limit	Line	Level	Factor	Loss	Factor	Pos	Pos	Avg.		
2		(MHz)	(dBμV/m)	(dB)	(dBμV/m)	(dBμV)	(dB/m)	(dB)	(dB)	(cm)	(deg)	(P/A)	(H/V)	
802.11ac VHT80 CH 138 5690MHz		11380	42.49	-31.51	74	44.61	38.28	17.16	57.56	100	0	P	H	
		17070	45.76	-28.24	74	38.78	42.16	20.65	55.83	100	0	P	H	
													H	
													H	
			11380	42.88	-31.12	74	45	38.28	17.16	57.56	100	0	P	V
			17070	46.7	-27.3	74	39.72	42.16	20.65	55.83	100	0	P	V
														V
Remark	1. No other spurious found. 2. All results are PASS against Peak and Average limit line.													



Emission below 1GHz
WIFI 802.11a (LF @ 3m)

WIFI Ant. 2	Note	Frequency (MHz)	Level (dBµV/m)	Over Limit (dB)	Limit Line (dBµV/m)	Read Level (dBµV)	Antenna Factor (dB/m)	Cable Loss (dB)	Preamp Factor (dB)	Ant Pos (cm)	Table Pos (deg)	Peak Avg. (P/A)	Pol. (H/V)
		30.27	27.99	-12.01	40	32.27	26	1.07	31.35	-	-	P	H
		107.22	32.53	-10.97	43.5	45.38	17.12	1.55	31.52	-	-	P	H
		240.06	37.26	-8.74	46	48.5	18.09	2.07	31.4	-	-	P	H
		300	29.82	-16.18	46	38.97	19.8	2.32	31.27	-	-	P	H
		659.8	37.31	-8.69	46	38.5	26	3.57	30.76	-	-	P	H
		780.2	38.39	-7.61	46	37.61	27.5	3.9	30.62	100	0	P	H
													H
													H
													H
													H
													H
													H
802.11a LF		35.13	28.49	-11.51	40	35.53	23.3	1.07	31.41	-	-	P	V
		99.66	32.35	-11.15	43.5	46.19	16.4	1.28	31.52	-	-	P	V
		240.06	28.77	-17.23	46	40.01	18.09	2.07	31.4	-	-	P	V
		456.1	25.98	-20.02	46	30.95	23.23	2.89	31.09	-	-	P	V
		659.8	35.89	-10.11	46	37.08	26	3.57	30.76	100	0	P	V
		940.5	34.06	-11.94	46	30.53	29.99	4.07	30.53	-	-	P	V
													V
													V
													V
													V
													V
													V
													V
Remark	1. No other spurious found. 2. All results are PASS against limit line.												



Emission below 1GHz
WIFI 802.11ac VHT20 (LF @ 3m)

WIFI Ant. 2	Note	Frequency (MHz)	Level (dBμV/m)	Over Limit (dB)	Limit Line (dBμV/m)	Read Level (dBμV)	Antenna Factor (dB/m)	Cable Loss (dB)	Preamp Factor (dB)	Ant Pos (cm)	Table Pos (deg)	Peak Avg. (P/A)	Pol. (H/V)
		91.29	30.92	-12.58	43.5	45.94	15.23	1.28	31.53	-	-	P	H
		193.08	23.98	-19.52	43.5	37.94	15.65	1.87	31.48	-	-	P	H
		240.06	37.14	-8.86	46	48.38	18.09	2.07	31.4	-	-	P	H
		300	29.1	-16.9	46	38.25	19.8	2.32	31.27	-	-	P	H
		659.8	36.81	-9.19	46	38	26	3.57	30.76	-	-	P	H
		780.2	39.11	-6.89	46	38.33	27.5	3.9	30.62	100	0	P	H
													H
													H
													H
													H
													H
													H
802.11ac VHT20 LF		34.32	32.79	-7.21	40	39.29	23.84	1.07	31.41	100	0	P	V
		102.09	30.65	-12.85	43.5	44.04	16.58	1.55	31.52	-	-	P	V
		240.06	28.63	-17.37	46	39.87	18.09	2.07	31.4	-	-	P	V
		540.1	31.06	-14.94	46	34.24	24.52	3.24	30.94	-	-	P	V
		780.2	34.72	-11.28	46	33.94	27.5	3.9	30.62	-	-	P	V
		836.9	34.05	-11.95	46	32.07	28.45	4.1	30.57	-	-	P	V
													V
													V
													V
													V
													V
													V
													V
Remark	1. No other spurious found. 2. All results are PASS against limit line.												



Emission below 1GHz
WIFI 802.11ac VHT40 (LF @ 3m)

WIFI Ant. 2	Note	Frequency (MHz)	Level (dBμV/m)	Over Limit (dB)	Limit Line (dBμV/m)	Read Level (dBμV)	Antenna Factor (dB/m)	Cable Loss (dB)	Preamp Factor (dB)	Ant Pos (cm)	Table Pos (deg)	Peak Avg. (P/A)	Pol. (H/V)
		89.13	31.37	-12.13	43.5	46.65	14.98	1.28	31.54	-	-	P	H
		192	23.77	-19.73	43.5	37.78	15.6	1.87	31.48	-	-	P	H
		240.06	37.25	-8.75	46	48.49	18.09	2.07	31.4	-	-	P	H
		320.3	29.31	-16.69	46	37.78	20.37	2.41	31.25	-	-	P	H
		780.2	39.56	-6.44	46	38.78	27.5	3.9	30.62	100	0	P	H
		899.9	35	-11	46	32.37	29	4.17	30.54	-	-	P	H
													H
													H
													H
													H
													H
													H
802.11ac VHT40 LF		35.13	32.13	-7.87	40	39.17	23.3	1.07	31.41	100	0	P	V
		101.82	30.45	-13.05	43.5	43.84	16.58	1.55	31.52	-	-	P	V
		240.06	28.34	-17.66	46	39.58	18.09	2.07	31.4	-	-	P	V
		439.3	25.52	-20.48	46	30.79	22.95	2.89	31.11	-	-	P	V
		659.8	35.37	-10.63	46	36.56	26	3.57	30.76	-	-	P	V
		899.9	34.08	-11.92	46	31.45	29	4.17	30.54	-	-	P	V
													V
													V
													V
													V
													V
													V
													V
Remark	1. No other spurious found. 2. All results are PASS against limit line.												



Emission below 1GHz
WIFI 802.11ac VHT80 (LF @ 3m)

WIFI Ant. 2	Note	Frequency (MHz)	Level (dBμV/m)	Over Limit (dB)	Limit Line (dBμV/m)	Read Level (dBμV)	Antenna Factor (dB/m)	Cable Loss (dB)	Preamp Factor (dB)	Ant Pos (cm)	Table Pos (deg)	Peak Avg. (P/A)	Pol. (H/V)
		30.27	27.58	-12.42	40	31.86	26	1.07	31.35	-	-	P	H
		101.01	34.54	-8.96	43.5	48.02	16.49	1.55	31.52	-	-	P	H
		240.06	34	-12	46	45.24	18.09	2.07	31.4	-	-	P	H
		479.9	29.82	-16.18	46	34.07	23.76	3.04	31.05	-	-	P	H
		659.8	38.43	-7.57	46	39.62	26	3.57	30.76	-	-	P	H
		780.2	39.34	-6.66	46	38.56	27.5	3.9	30.62	100	0	P	H
													H
													H
													H
													H
													H
													H
802.11ac VHT80 LF		34.32	32.63	-7.37	40	39.13	23.84	1.07	31.41	100	0	P	V
		101.82	33.76	-9.74	43.5	47.15	16.58	1.55	31.52	-	-	P	V
		240.06	30.09	-15.91	46	41.33	18.09	2.07	31.4	-	-	P	V
		540.1	31.18	-14.82	46	34.36	24.52	3.24	30.94	-	-	P	V
		780.2	35.87	-10.13	46	35.09	27.5	3.9	30.62	-	-	P	V
		949.6	34.13	-11.87	46	30.39	30.2	4.07	30.53	-	-	P	V
													V
													V
													V
													V
													V
													V
													V
Remark	1. No other spurious found. 2. All results are PASS against limit line.												



Note symbol

*	Fundamental Frequency which can be ignored. However, the level of any unwanted emissions shall not exceed the level of the fundamental frequency.
!	Test result is over limit line.
P/A	Peak or Average
H/V	Horizontal or Vertical



A calculation example for radiated spurious emission is shown as below:

WIFI Ant. 2	Note	Frequency (MHz)	Level (dBμV/m)	Over Limit (dB)	Limit Line (dBμV/m)	Read Level (dBμV)	Antenna Factor (dB/m)	Cable Loss (dB)	Preamp Factor (dB)	Ant Pos (cm)	Table Pos (deg)	Peak Avg. (P/A)	Pol. (H/V)
802.11b CH 01		2390	55.45	-18.55	74	54.51	32.22	4.58	35.86	103	308	P	H
2412MHz		2390	43.54	-10.46	54	42.6	32.22	4.58	35.86	103	308	A	H

- 1. Level(dBμV/m) =
Antenna Factor(dB/m) + Cable Loss(dB) + Read Level(dBμV) - Preamp Factor(dB)
- 2. Over Limit(dB) = Level(dBμV/m) – Limit Line(dBμV/m)

For Peak Limit @ 2390MHz:

- 1. Level(dBμV/m)
= Antenna Factor(dB/m) + Cable Loss(dB) + Read Level(dBμV) - Preamp Factor(dB)
= 32.22(dB/m) + 4.58(dB) + 54.51(dBμV) – 35.86 (dB)
= 55.45 (dBμV/m)
- 2. Over Limit(dB)
= Level(dBμV/m) – Limit Line(dBμV/m)
= 55.45(dBμV/m) – 74(dBμV/m)
= -18.55(dB)

For Average Limit @ 2390MHz:

- 1. Level(dBμV/m)
= Antenna Factor(dB/m) + Cable Loss(dB) + Read Level(dBμV) - Preamp Factor(dB)
= 32.22(dB/m) + 4.58(dB) + 42.6(dBμV) – 35.86 (dB)
= 43.54 (dBμV/m)
- 2. Over Limit(dB)
= Level(dBμV/m) – Limit Line(dBμV/m)
= 43.54(dBμV/m) – 54(dBμV/m)
= -10.46(dB)

Both peak and average measured complies with the limit line, so test result is “PASS”.



<CDD Mode>

Band 1 - 5150~5250MHz

WIFI 802.11a (Band Edge @ 3m)

WIFI	Note	Frequency	Level	Over	Limit	Read	Antenna	Cable	Preamp	Ant	Table	Peak	Pol.	
Ant.				Limit	Line	Level	Factor	Loss	Factor	Pos	Pos	Avg.		
1+2		(MHz)	(dBμV/m)	(dB)	(dBμV/m)	(dBμV)	(dB/m)	(dB)	(dB)	(cm)	(deg)	(P/A)	(H/V)	
802.11a CH 36 5180MHz		5146.64	52.59	-21.41	74	41.94	34.66	11.21	35.22	100	281	P	H	
		5149.76	44.44	-9.56	54	33.79	34.66	11.21	35.22	100	281	A	H	
	*	5180	107.32	-	-	96.59	34.74	11.21	35.22	100	281	P	H	
	*	5180	99.67	-	-	88.94	34.74	11.21	35.22	100	281	A	H	
													H	
														H
			5149.76	52.4	-21.6	74	41.75	34.66	11.21	35.22	380	178	P	V
			5149.5	43.58	-10.42	54	32.93	34.66	11.21	35.22	380	178	A	V
	*		5180	106.61	-	-	95.88	34.74	11.21	35.22	380	178	P	V
	*		5180	99.31	-	-	88.58	34.74	11.21	35.22	380	178	A	V
														V
														V
802.11a CH 44 5220MHz		5053.56	49.7	-24.3	74	39.38	34.42	11.11	35.21	100	281	P	H	
		5101.92	41.9	-12.1	54	31.4	34.54	11.18	35.22	100	281	A	H	
	*	5220	107.57	-	-	96.72	34.82	11.25	35.22	100	281	P	H	
	*	5220	100.09	-	-	89.24	34.82	11.25	35.22	100	281	A	H	
			5437.68	50.6	-23.4	74	38.61	35.34	11.89	35.24	100	281	P	H
			5433.6	42.63	-11.37	54	30.64	35.34	11.89	35.24	100	281	A	H
			5050.18	50.3	-23.7	74	39.98	34.42	11.11	35.21	337	166	P	V
			5115.96	41.86	-12.14	54	31.32	34.58	11.18	35.22	337	166	A	V
	*		5220	105.98	-	-	95.13	34.82	11.25	35.22	337	166	P	V
	*		5220	98.74	-	-	87.89	34.82	11.25	35.22	337	166	A	V
			5379.12	49.94	-24.06	74	38.19	35.22	11.76	35.23	337	166	P	V
			5431.44	42.46	-11.54	54	30.47	35.34	11.89	35.24	337	166	A	V



802.11a CH 48 5240MHz		5128.7	50.54	-23.46	74	39.96	34.62	11.18	35.22	100	280	P	H
		5101.92	41.7	-12.3	54	31.2	34.54	11.18	35.22	100	280	A	H
	*	5240	107.66	-	-	96.64	34.86	11.38	35.22	100	280	P	H
	*	5240	100.31	-	-	89.29	34.86	11.38	35.22	100	280	A	H
		5449.2	50.05	-23.95	74	38.02	35.38	11.89	35.24	100	280	P	H
		5454.72	42.78	-11.22	54	30.75	35.38	11.89	35.24	100	280	A	H
		5102.44	51.8	-22.2	74	41.3	34.54	11.18	35.22	369	178	P	V
		5101.14	41.57	-12.43	54	31.07	34.54	11.18	35.22	369	178	A	V
	*	5240	106.48	-	-	95.46	34.86	11.38	35.22	369	178	P	V
	*	5240	99.46	-	-	88.44	34.86	11.38	35.22	369	178	A	V
		5368.08	50.43	-23.57	74	38.72	35.18	11.76	35.23	369	178	P	V
		5457.6	42.61	-11.39	54	30.58	35.38	11.89	35.24	369	178	A	V
Remark	1. No other spurious found. 2. All results are PASS against Peak and Average limit line.												



Band 1 5150~5250MHz
WIFI 802.11a (Harmonic @ 3m)

WIFI	Note	Frequency	Level	Over	Limit	Read	Antenna	Cable	Preamp	Ant	Table	Peak	Pol.
Ant.				Limit	Line	Level	Factor	Loss	Factor	Pos	Pos	Avg.	
1+2		(MHz)	(dBμV/m)	(dB)	(dBμV/m)	(dBμV)	(dB/m)	(dB)	(dB)	(cm)	(deg)	(P/A)	(H/V)
802.11a CH 36 5180MHz		10360	41.74	-32.26	74	46.41	37.37	17.17	59.21	100	0	P	H
		15540	44.73	-29.27	74	41.94	40.36	19.61	57.18	100	0	P	H
													H
													H
		10360	42.66	-31.34	74	47.33	37.37	17.17	59.21	100	0	P	V
		15540	44.92	-29.08	74	42.13	40.36	19.61	57.18	100	0	P	V
													V
													V
802.11a CH 44 5220MHz		10440	43.28	-30.72	74	47.83	37.43	17.17	59.15	100	0	P	H
		15660	44.05	-29.95	74	40.9	40.58	19.68	57.11	100	0	P	H
													H
													H
		10440	44	-30	74	48.55	37.43	17.17	59.15	100	0	P	V
		15660	44.61	-29.39	74	41.46	40.58	19.68	57.11	100	0	P	V
													V
													V
802.11a CH 48 5240MHz		10480	43.1	-30.9	74	47.56	37.48	17.17	59.11	100	0	P	H
		15720	43.7	-30.3	74	40.34	40.7	19.73	57.07	100	0	P	H
													H
													H
		10480	44.69	-29.31	74	49.15	37.48	17.17	59.11	100	0	P	V
		15720	44.02	-29.98	74	40.66	40.7	19.73	57.07	100	0	P	V
													V
													V
Remark	1. No other spurious found. 2. All results are PASS against Peak and Average limit line.												



**Band 1 5150~5250MHz
WIFI 802.11ac VHT20 (Band Edge @ 3m)**

WIFI	Note	Frequency	Level	Over	Limit	Read	Antenna	Cable	Preamp	Ant	Table	Peak	Pol.	
Ant.				Limit	Line	Level	Factor	Loss	Factor	Pos	Pos	Avg.		
1+2		(MHz)	(dBμV/m)	(dB)	(dBμV/m)	(dBμV)	(dB/m)	(dB)	(dB)	(cm)	(deg)	(P/A)	(H/V)	
802.11ac VHT20 CH 36 5180MHz		5149.76	52.73	-21.27	74	42.08	34.66	11.21	35.22	100	282	P	H	
		5125.84	44.4	-9.6	54	33.82	34.62	11.18	35.22	100	282	A	H	
	*	5180	105.33	-	-	94.6	34.74	11.21	35.22	100	282	P	H	
	*	5180	97	-	-	86.27	34.74	11.21	35.22	100	282	A	H	
													H	
													H	
			5122.2	51.17	-22.83	74	40.63	34.58	11.18	35.22	363	179	P	V
			5139.62	43.6	-10.4	54	32.98	34.66	11.18	35.22	363	179	A	V
		*	5180	104.75	-	-	94.02	34.74	11.21	35.22	363	179	P	V
		*	5180	95.65	-	-	84.92	34.74	11.21	35.22	363	179	A	V
													V	
													V	
802.11ac VHT20 CH 44 5220MHz		5020.28	50.04	-23.96	74	39.8	34.34	11.11	35.21	100	281	P	H	
		5146.9	41.95	-12.05	54	31.3	34.66	11.21	35.22	100	281	A	H	
		* 5220	106.69	-	-	95.84	34.82	11.25	35.22	100	281	P	H	
		* 5220	97.84	-	-	86.99	34.82	11.25	35.22	100	281	P	H	
			5404.8	50.02	-23.98	74	38.1	35.26	11.89	35.23	100	281	P	H
			5432.16	42.15	-11.85	54	30.16	35.34	11.89	35.24	100	281	A	H
			5101.92	50.55	-23.45	74	40.05	34.54	11.18	35.22	339	170	P	V
			5135.46	41.76	-12.24	54	31.18	34.62	11.18	35.22	339	170	A	V
		*	5220	104.62	-	-	93.77	34.82	11.25	35.22	339	170	P	V
		*	5220	96.7	-	-	85.85	34.82	11.25	35.22	339	170	A	V
		5376.48	49.32	-24.68	74	37.61	35.18	11.76	35.23	339	170	P	V	
		5435.28	41.94	-12.06	54	29.95	35.34	11.89	35.24	339	170	A	V	



802.11ac VHT20 CH 48 5240MHz		5049.92	50.12	-23.88	74	39.8	34.42	11.11	35.21	100	280	P	H
		5138.84	41.93	-12.07	54	31.35	34.62	11.18	35.22	100	280	A	H
	*	5240	107.01	-	-	95.99	34.86	11.38	35.22	100	280	P	H
	*	5240	98.05	-	-	87.03	34.86	11.38	35.22	100	280	A	H
		5457.36	50.5	-23.5	74	38.47	35.38	11.89	35.24	100	280	P	H
		5456.64	42.36	-11.64	54	30.33	35.38	11.89	35.24	100	280	A	H
		5120.38	50.42	-23.58	74	39.88	34.58	11.18	35.22	339	166	P	V
		5123.5	41.68	-12.32	54	31.1	34.62	11.18	35.22	339	166	A	V
	*	5240	104.78	-	-	93.76	34.86	11.38	35.22	339	166	P	V
	*	5240	97.25	-	-	86.23	34.86	11.38	35.22	339	166	A	V
		5454.72	49.02	-24.98	74	36.99	35.38	11.89	35.24	339	166	P	V
	5458.56	42.05	-11.95	54	30.02	35.38	11.89	35.24	339	166	A	V	
Remark	1. No other spurious found. 2. All results are PASS against Peak and Average limit line.												



Band 1 5150~5250MHz
WIFI 802.11ac VHT20 (Harmonic @ 3m)

WIFI	Note	Frequency	Level	Over	Limit	Read	Antenna	Cable	Preamp	Ant	Table	Peak	Pol.
Ant.				Limit	Line	Level	Factor	Loss	Factor	Pos	Pos	Avg.	
1+2		(MHz)	(dBμV/m)	(dB)	(dBμV/m)	(dBμV)	(dB/m)	(dB)	(dB)	(cm)	(deg)	(P/A)	(H/V)
802.11ac VHT20 CH 36 5180MHz		10360	42.92	-31.08	74	47.59	37.37	17.17	59.21	100	0	P	H
		15540	43.87	-30.13	74	41.08	40.36	19.61	57.18	100	0	P	H
													H
													H
		10360	43.37	-30.63	74	48.04	37.37	17.17	59.21	100	0	P	V
		15540	44.14	-29.86	74	41.35	40.36	19.61	57.18	100	0	P	V
													V
802.11ac VHT20 CH 44 5220MHz		10440	42.92	-31.08	74	47.47	37.43	17.17	59.15	100	0	P	H
		15660	43.58	-30.42	74	40.43	40.58	19.68	57.11	100	0	P	H
													H
													H
		10440	43.2	-30.8	74	47.75	37.43	17.17	59.15	100	0	P	V
		15660	43.86	-30.14	74	40.71	40.58	19.68	57.11	100	0	P	V
													V
802.11ac VHT20 CH 48 5240MHz		10480	43.34	-30.66	74	47.8	37.48	17.17	59.11	100	0	P	H
		15720	44.62	-29.38	74	41.26	40.7	19.73	57.07	100	0	P	H
													H
													H
		10480	43.16	-30.84	74	47.62	37.48	17.17	59.11	100	0	P	V
		15720	44.14	-29.86	74	40.78	40.7	19.73	57.07	100	0	P	V
													V
Remark	1. No other spurious found.												
	2. All results are PASS against Peak and Average limit line.												



Band 1 5150~5250MHz
WIFI 802.11ac VHT40 (Band Edge @ 3m)

WIFI	Note	Frequency	Level	Over	Limit	Read	Antenna	Cable	Preamp	Ant	Table	Peak	Pol.
Ant.				Limit	Line	Level	Factor	Loss	Factor	Pos	Pos	Avg.	
1+2		(MHz)	(dBμV/m)	(dB)	(dBμV/m)	(dBμV)	(dB/m)	(dB)	(dB)	(cm)	(deg)	(P/A)	(H/V)
802.11ac VHT40 CH 38 5190MHz		5146.64	58.45	-15.55	74	47.8	34.66	11.21	35.22	100	281	P	H
		5149.76	51.66	-2.34	54	41.01	34.66	11.21	35.22	100	281	A	H
	*	5190	102.67	-	-	91.9	34.74	11.25	35.22	100	281	P	H
	*	5190	95.04	-	-	84.27	34.74	11.25	35.22	100	281	A	H
		5457.6	49.97	-24.03	74	37.94	35.38	11.89	35.24	100	281	P	H
		5452.8	42.3	-11.7	54	30.27	35.38	11.89	35.24	100	281	A	H
		5147.68	57.62	-16.38	74	46.97	34.66	11.21	35.22	345	171	P	V
		5149.24	50.19	-3.81	54	39.54	34.66	11.21	35.22	345	171	A	V
	*	5190	102.62	-	-	91.85	34.74	11.25	35.22	345	171	P	V
	*	5190	94.94	-	-	84.17	34.74	11.25	35.22	345	171	A	V
		5370.48	50.59	-23.41	74	38.88	35.18	11.76	35.23	345	171	P	V
		5439.84	42.27	-11.73	54	30.28	35.34	11.89	35.24	345	171	A	V
802.11ac VHT40 CH 46 5230MHz		5116.74	50.36	-23.64	74	39.82	34.58	11.18	35.22	100	280	P	H
		5148.72	42.82	-11.18	54	32.17	34.66	11.21	35.22	100	280	A	H
	*	5230	104.08	-	-	93.06	34.86	11.38	35.22	100	280	P	H
	*	5230	95.37	-	-	84.35	34.86	11.38	35.22	100	280	A	H
		5376	50.62	-23.38	74	38.91	35.18	11.76	35.23	100	280	P	H
		5445.6	42.5	-11.5	54	30.47	35.38	11.89	35.24	100	280	A	H
		5107.12	51.68	-22.32	74	41.14	34.58	11.18	35.22	318	172	P	V
		5144.3	42.62	-11.38	54	31.97	34.66	11.21	35.22	318	172	A	V
	*	5230	102.84	-	-	91.82	34.86	11.38	35.22	318	172	P	V
	*	5230	95.09	-	-	84.07	34.86	11.38	35.22	318	172	A	V
	5452.56	49.73	-24.27	74	37.7	35.38	11.89	35.24	318	172	P	V	
	5421.12	42.41	-11.59	54	30.46	35.3	11.89	35.24	318	172	A	V	
Remark	1. No other spurious found. 2. All results are PASS against Peak and Average limit line.												



Band 1 5150~5250MHz
WIFI 802.11ac VHT40 (Harmonic @ 3m)

WIFI	Note	Frequency	Level	Over	Limit	Read	Antenna	Cable	Preamp	Ant	Table	Peak	Pol.
Ant.				Limit	Line	Level	Factor	Loss	Factor	Pos	Pos	Avg.	
1+2		(MHz)	(dBμV/m)	(dB)	(dBμV/m)	(dBμV)	(dB/m)	(dB)	(dB)	(cm)	(deg)	(P/A)	(H/V)
802.11ac VHT40 CH 38 5190MHz		10380	43.99	-30.01	74	48.63	37.38	17.17	59.19	100	0	P	H
		15570	43.92	-30.08	74	41.03	40.42	19.63	57.16	100	0	P	H
													H
													H
		10380	42.7	-31.3	74	47.34	37.38	17.17	59.19	100	0	P	V
		15570	43.07	-30.93	74	40.18	40.42	19.63	57.16	100	0	P	V
													V
802.11ac VHT40 CH 46 5230MHz		10460	42.07	-31.93	74	46.59	37.45	17.17	59.14	100	0	P	H
		15690	43.38	-30.62	74	40.13	40.64	19.7	57.09	100	0	P	H
													H
													H
		10460	42.98	-31.02	74	47.5	37.45	17.17	59.14	100	0	P	V
		15690	43.8	-30.2	74	40.55	40.64	19.7	57.09	100	0	P	V
													V
Remark	1. No other spurious found.												
	2. All results are PASS against Peak and Average limit line.												



Band 1 5150~5250MHz
WIFI 802.11ac VHT80 (Band Edge @ 3m)

WIFI	Note	Frequency	Level	Over	Limit	Read	Antenna	Cable	Preamp	Ant	Table	Peak	Pol.
Ant.				Limit	Line	Level	Factor	Loss	Factor	Pos	Pos	Avg.	
1+2		(MHz)	(dBμV/m)	(dB)	(dBμV/m)	(dBμV)	(dB/m)	(dB)	(dB)	(cm)	(deg)	(P/A)	(H/V)
802.11ac VHT80 CH 42 5210MHz		5121.16	60.24	-13.76	74	49.7	34.58	11.18	35.22	100	282	P	H
		5116.22	52.79	-1.21	54	42.25	34.58	11.18	35.22	100	282	A	H
	*	5210	101.78	-	-	90.93	34.82	11.25	35.22	100	282	P	H
	*	5210	93.56	-	-	82.71	34.82	11.25	35.22	100	282	A	H
		5357.76	50.64	-23.36	74	38.97	35.14	11.76	35.23	100	282	P	H
		5351.28	43.79	-10.21	54	32.12	35.14	11.76	35.23	100	282	A	H
		5145.6	57.81	-16.19	74	47.16	34.66	11.21	35.22	288	181	P	V
		5149.24	51.03	-2.97	54	40.38	34.66	11.21	35.22	288	181	A	V
	*	5210	100.69	-	-	89.84	34.82	11.25	35.22	288	181	P	V
	*	5210	92.58	-	-	81.73	34.82	11.25	35.22	288	181	A	V
		5457.12	50.56	-23.44	74	38.53	35.38	11.89	35.24	288	181	P	V
	5351.76	43.25	-10.75	54	31.58	35.14	11.76	35.23	288	181	A	V	
Remark	1. No other spurious found. 2. All results are PASS against Peak and Average limit line.												



Band 1 5150~5250MHz
WIFI 802.11ac VHT80 (Harmonic @ 3m)

WIFI	Note	Frequency	Level	Over	Limit	Read	Antenna	Cable	Preamp	Ant	Table	Peak	Pol.	
Ant.				Limit	Line	Level	Factor	Loss	Factor	Pos	Pos	Avg.		
1+2		(MHz)	(dBμV/m)	(dB)	(dBμV/m)	(dBμV)	(dB/m)	(dB)	(dB)	(cm)	(deg)	(P/A)	(H/V)	
802.11ac VHT80 CH 42 5210MHz		10420	43.13	-30.87	74	47.71	37.42	17.17	59.17	100	0	P	H	
		15630	43.04	-30.96	74	39.93	40.55	19.68	57.12	100	0	P	H	
													H	
													H	
			10420	42.99	-31.01	74	47.57	37.42	17.17	59.17	100	0	P	V
			15630	42.89	-31.11	74	39.78	40.55	19.68	57.12	100	0	P	V
														V
													V	
Remark	1. No other spurious found. 2. All results are PASS against Peak and Average limit line.													



Band 2 - 5250~5350MHz
WIFI 802.11a (Band Edge @ 3m)

WIFI Ant. 1+2	Note	Frequency (MHz)	Level (dBμV/m)	Over Limit (dB)	Limit Line (dBμV/m)	Read Level (dBμV)	Antenna Factor (dB/m)	Cable Loss (dB)	Preamp Factor (dB)	Ant Pos (cm)	Table Pos (deg)	Peak Avg. (P/A)	Pol. (H/V)
802.11a CH 52 5260MHz		5013	49.66	-24.34	74	39.46	34.34	11.07	35.21	363	257	P	H
		5138.32	41.66	-12.34	54	31.08	34.62	11.18	35.22	363	257	A	H
	*	5260	106.66	-	-	95.57	34.94	11.38	35.23	363	257	P	H
	*	5260	100.09	-	-	89	34.94	11.38	35.23	363	257	A	H
		5398.32	49.7	-24.3	74	37.78	35.26	11.89	35.23	363	257	P	H
		5423.52	41.71	-12.29	54	29.76	35.3	11.89	35.24	363	257	A	H
		5034.58	51.13	-22.87	74	40.85	34.38	11.11	35.21	363	174	P	V
		5123.24	41.8	-12.2	54	31.22	34.62	11.18	35.22	363	174	A	V
	*	5260	106.43	-	-	95.34	34.94	11.38	35.23	363	174	P	V
	*	5260	99.78	-	-	88.69	34.94	11.38	35.23	363	174	A	V
		5364	50	-24	74	38.29	35.18	11.76	35.23	363	174	P	V
		5423.76	41.65	-12.35	54	29.7	35.3	11.89	35.24	363	174	A	V
802.11a CH 60 5300MHz		5062.92	49.96	-24.04	74	39.57	34.46	11.14	35.21	380	257	P	H
		5120.38	41.85	-12.15	54	31.31	34.58	11.18	35.22	380	257	A	H
	*	5300	107.32	-	-	96.02	35.02	11.51	35.23	380	257	P	H
	*	5300	100.49	-	-	89.19	35.02	11.51	35.23	380	257	A	H
		5373.6	49.98	-24.02	74	38.27	35.18	11.76	35.23	380	257	P	H
		5350.32	42.01	-11.99	54	30.34	35.14	11.76	35.23	380	257	A	H
		5100.1	50.9	-23.1	74	40.4	34.54	11.18	35.22	379	171	P	V
		5132.6	41.75	-12.25	54	31.17	34.62	11.18	35.22	379	171	A	V
	*	5300	104.62	-	-	93.32	35.02	11.51	35.23	379	171	P	V
	*	5300	99.39	-	-	88.09	35.02	11.51	35.23	379	171	A	V
		5450.64	51.41	-22.59	74	39.38	35.38	11.89	35.24	379	171	P	V
		5350.32	42.16	-11.84	54	30.49	35.14	11.76	35.23	379	171	A	V



802.11a CH 64 5320MHz	*	5320	106.5	-	-	95.04	35.06	11.63	35.23	377	287	P	H
	*	5320	99.83	-	-	88.37	35.06	11.63	35.23	377	287	A	H
		5381.44	50.32	-23.68	74	38.44	35.22	11.89	35.23	377	287	P	H
		5350.72	42.56	-11.44	54	30.89	35.14	11.76	35.23	377	287	A	H
													H
													H
	*	5320	104.82	-	-	93.36	35.06	11.63	35.23	377	175	P	V
	*	5320	99.32	-	-	87.86	35.06	11.63	35.23	377	175	A	V
		5389.12	50.76	-23.24	74	38.88	35.22	11.89	35.23	377	175	P	V
		5350.88	42.9	-11.1	54	31.23	35.14	11.76	35.23	377	175	A	V
													V
													V
Remark	1. No other spurious found. 2. All results are PASS against Peak and Average limit line.												



Band 2 5250~5350MHz
WIFI 802.11a (Harmonic @ 3m)

WIFI	Note	Frequency	Level	Over	Limit	Read	Antenna	Cable	Preamp	Ant	Table	Peak	Pol.
Ant.				Limit	Line	Level	Factor	Loss	Factor	Pos	Pos	Avg.	
1+2		(MHz)	(dBμV/m)	(dB)	(dBμV/m)	(dBμV)	(dB/m)	(dB)	(dB)	(cm)	(deg)	(P/A)	(H/V)
802.11a CH 52 5260MHz		10520	43.32	-30.68	74	47.72	37.51	17.17	59.08	100	0	P	H
		15780	43.42	-30.58	74	39.9	40.8	19.75	57.03	100	0	P	H
													H
													H
		10520	43.95	-30.05	74	48.35	37.51	17.17	59.08	100	0	P	V
		15780	43.61	-30.39	74	40.09	40.8	19.75	57.03	100	0	P	V
													V
													V
802.11a CH 60 5300MHz		10600	44.62	-29.38	74	48.83	37.58	17.17	58.96	100	0	P	H
		15900	45.11	-28.89	74	41.24	41.01	19.82	56.96	100	0	P	H
													H
													H
		10600	44.02	-29.98	74	48.23	37.58	17.17	58.96	100	0	P	V
		15900	45.68	-28.32	74	41.81	41.01	19.82	56.96	100	0	P	V
													V
													V
802.11a CH 64 5320MHz		10640	43.91	-30.09	74	48.04	37.61	17.17	58.91	100	0	P	H
		15960	43.87	-30.13	74	39.78	41.14	19.87	56.92	100	0	P	H
													H
													H
		10640	42.95	-31.05	74	47.08	37.61	17.17	58.91	100	0	P	V
		15960	44.86	-29.14	74	40.77	41.14	19.87	56.92	100	0	P	V
													V
													V
Remark	1. No other spurious found. 2. All results are PASS against Peak and Average limit line.												



Band 2 5250~5350MHz
WIFI 802.11ac VHT20 (Band Edge @ 3m)

WIFI	Note	Frequency	Level	Over	Limit	Read	Antenna	Cable	Preamp	Ant	Table	Peak	Pol.
Ant.				Limit	Line	Level	Factor	Loss	Factor	Pos	Pos	Avg.	
1+2		(MHz)	(dBμV/m)	(dB)	(dBμV/m)	(dBμV)	(dB/m)	(dB)	(dB)	(cm)	(deg)	(P/A)	(H/V)
802.11ac VHT20 CH 52 5260MHz		5001.56	51.95	-22.05	74	41.79	34.3	11.07	35.21	260	270	P	H
		5116.22	41.71	-12.29	54	31.17	34.58	11.18	35.22	260	270	A	H
	*	5260	106.11	-	-	95.02	34.94	11.38	35.23	260	270	P	H
	*	5260	98.83	-	-	87.74	34.94	11.38	35.23	260	270	A	H
		5426.4	49.6	-24.4	74	37.65	35.3	11.89	35.24	260	270	P	H
		5406.72	41.75	-12.25	54	29.83	35.26	11.89	35.23	260	270	A	H
		5054.86	50.87	-23.13	74	40.51	34.46	11.11	35.21	312	170	P	V
		5092.04	41.7	-12.3	54	31.24	34.54	11.14	35.22	312	170	A	V
	*	5260	104.18	-	-	93.09	34.94	11.38	35.23	312	170	P	V
	*	5260	97.74	-	-	86.65	34.94	11.38	35.23	312	170	A	V
		5450.16	49.57	-24.43	74	37.54	35.38	11.89	35.24	312	170	P	V
		5450.88	41.74	-12.26	54	29.71	35.38	11.89	35.24	312	170	A	V
802.11ac VHT20 CH 60 5300MHz		5114.92	50.36	-23.64	74	39.82	34.58	11.18	35.22	256	270	P	H
		5111	41.75	-12.25	54	31.21	34.58	11.18	35.22	256	270	A	H
	*	5300	105.72	-	-	94.42	35.02	11.51	35.23	256	270	P	H
	*	5300	98.65	-	-	87.35	35.02	11.51	35.23	256	270	A	H
		5355.6	51.12	-22.88	74	39.45	35.14	11.76	35.23	256	270	P	H
		5355.36	45.13	-8.87	54	33.46	35.14	11.76	35.23	256	270	A	H
		5150	50.4	-23.6	74	39.75	34.66	11.21	35.22	325	171	P	V
		5129.74	41.63	-12.37	54	31.05	34.62	11.18	35.22	325	171	A	V
	*	5300	105.45	-	-	94.15	35.02	11.51	35.23	325	171	P	V
	*	5300	98	-	-	86.7	35.02	11.51	35.23	325	171	A	V
	5443.44	51.44	-22.56	74	39.45	35.34	11.89	35.24	325	171	P	V	
	5355.12	42.41	-11.59	54	30.74	35.14	11.76	35.23	325	171	A	V	



802.11ac VHT20 CH 64 5320MHz	*	5320	106.1	-	-	94.64	35.06	11.63	35.23	255	270	P	H
	*	5320	98.67	-	-	87.21	35.06	11.63	35.23	255	270	A	H
		5350.4	52.1	-21.9	74	40.43	35.14	11.76	35.23	255	270	P	H
		5372	44.99	-9.01	54	33.28	35.18	11.76	35.23	255	270	A	H
													H
													H
	*	5320	105.04	-	-	93.58	35.06	11.63	35.23	322	171	P	V
	*	5320	98.32	-	-	86.86	35.06	11.63	35.23	322	171	A	V
		5371.36	51.25	-22.75	74	39.54	35.18	11.76	35.23	322	171	P	V
		5350.88	43.85	-10.15	54	32.18	35.14	11.76	35.23	322	171	A	V
												V	
												V	
Remark	1. No other spurious found. 2. All results are PASS against Peak and Average limit line.												



Band 2 5250~5350MHz
WIFI 802.11ac VHT20 (Harmonic @ 3m)

WIFI	Note	Frequency	Level	Over	Limit	Read	Antenna	Cable	Preamp	Ant	Table	Peak	Pol.
Ant.				Limit	Line	Level	Factor	Loss	Factor	Pos	Pos	Avg.	
1+2		(MHz)	(dBμV/m)	(dB)	(dBμV/m)	(dBμV)	(dB/m)	(dB)	(dB)	(cm)	(deg)	(P/A)	(H/V)
802.11ac VHT20 CH 52 5260MHz		10520	42.92	-31.08	74	47.32	37.51	17.17	59.08	100	0	P	H
		15780	43.36	-30.64	74	39.84	40.8	19.75	57.03	100	0	P	H
													H
													H
		10520	43.24	-30.76	74	47.64	37.51	17.17	59.08	100	0	P	V
		15780	43.53	-30.47	74	40.01	40.8	19.75	57.03	100	0	P	V
802.11ac VHT20 CH 60 5300MHz		10600	41.58	-32.42	74	45.79	37.58	17.17	58.96	100	0	P	H
		15900	43.33	-30.67	74	39.46	41.01	19.82	56.96	100	0	P	H
													H
													H
		10600	42.19	-31.81	74	46.4	37.58	17.17	58.96	100	0	P	V
		15900	43.93	-30.07	74	40.06	41.01	19.82	56.96	100	0	P	V
802.11ac VHT20 CH 64 5320MHz		10640	42.87	-31.13	74	47	37.61	17.17	58.91	100	0	P	H
		15960	44.02	-29.98	74	39.93	41.14	19.87	56.92	100	0	P	H
													H
													H
		10640	43.29	-30.71	74	47.42	37.61	17.17	58.91	100	0	P	V
		15960	44.09	-29.91	74	40	41.14	19.87	56.92	100	0	P	V
Remark	1. No other spurious found.												
	2. All results are PASS against Peak and Average limit line.												



Band 2 5250~5350MHz
WIFI 802.11ac VHT40 (Band Edge @ 3m)

WIFI	Note	Frequency	Level	Over	Limit	Read	Antenna	Cable	Preamp	Ant	Table	Peak	Pol.
Ant.				Limit	Line	Level	Factor	Loss	Factor	Pos	Pos	Avg.	
1+2		(MHz)	(dBμV/m)	(dB)	(dBμV/m)	(dBμV)	(dB/m)	(dB)	(dB)	(cm)	(deg)	(P/A)	(H/V)
802.11ac VHT40 CH 54 5270MHz		5052	50.02	-23.98	74	39.7	34.42	11.11	35.21	271	266	P	H
		5138.06	42.11	-11.89	54	31.53	34.62	11.18	35.22	271	266	A	H
	*	5270	102.7	-	-	91.48	34.94	11.51	35.23	271	266	P	H
	*	5270	95.96	-	-	84.74	34.94	11.51	35.23	271	266	A	H
		5352.48	51.47	-22.53	74	39.8	35.14	11.76	35.23	271	266	P	H
		5352	43.28	-10.72	54	31.61	35.14	11.76	35.23	271	266	A	H
		5135.98	49.99	-24.01	74	39.41	34.62	11.18	35.22	312	171	P	V
		5142.22	42.16	-11.84	54	31.51	34.66	11.21	35.22	312	171	A	V
	*	5270	101.58	-	-	90.36	34.94	11.51	35.23	312	171	P	V
	*	5270	95.3	-	-	84.08	34.94	11.51	35.23	312	171	A	V
		5396.16	49.92	-24.08	74	38	35.26	11.89	35.23	312	171	P	V
		5437.68	42.57	-11.43	54	30.58	35.34	11.89	35.24	312	171	A	V
802.11ac VHT40 CH 62 5310MHz		5041.08	50.22	-23.78	74	39.9	34.42	11.11	35.21	255	270	P	H
		5141.96	42.18	-11.82	54	31.53	34.66	11.21	35.22	255	270	A	H
	*	5310	103.2	-	-	91.74	35.06	11.63	35.23	255	270	P	H
	*	5310	96.62	-	-	85.16	35.06	11.63	35.23	255	270	A	H
		5353.92	57.18	-16.82	74	45.51	35.14	11.76	35.23	255	270	P	H
		5351.04	51.59	-2.41	54	39.92	35.14	11.76	35.23	255	270	A	H
		5073.06	50.06	-23.94	74	39.63	34.5	11.14	35.21	326	169	P	V
		5139.88	42.08	-11.92	54	31.46	34.66	11.18	35.22	326	169	A	V
	*	5310	103.05	-	-	91.59	35.06	11.63	35.23	326	169	P	V
	*	5310	95.76	-	-	84.3	35.06	11.63	35.23	326	169	A	V
	5350.8	55.78	-18.22	74	44.11	35.14	11.76	35.23	326	169	P	V	
	5350.56	49.72	-4.28	54	38.05	35.14	11.76	35.23	326	169	A	V	
Remark	1. No other spurious found. 2. All results are PASS against Peak and Average limit line.												



Band 2 5250~5350MHz
WIFI 802.11ac VHT40 (Harmonic @ 3m)

WIFI	Note	Frequency	Level	Over	Limit	Read	Antenna	Cable	Preamp	Ant	Table	Peak	Pol.
Ant.				Limit	Line	Level	Factor	Loss	Factor	Pos	Pos	Avg.	
1+2		(MHz)	(dBμV/m)	(dB)	(dBμV/m)	(dBμV)	(dB/m)	(dB)	(dB)	(cm)	(deg)	(P/A)	(H/V)
802.11ac VHT40 CH 54 5270MHz		10540	42.73	-31.27	74	47.08	37.53	17.17	59.05	100	0	P	H
		15810	43.43	-30.57	74	39.81	40.86	19.77	57.01	100	0	P	H
													H
													H
		10540	43.78	-30.22	74	48.13	37.53	17.17	59.05	100	0	P	V
		15810	44.44	-29.56	74	40.82	40.86	19.77	57.01	100	0	P	V
													V
802.11ac VHT40 CH 62 5310MHz		10620	42.12	-31.88	74	46.28	37.6	17.17	58.93	100	0	P	H
		15930	43.01	-30.99	74	39.03	41.08	19.84	56.94	100	0	P	H
													H
													H
		10620	42.49	-31.51	74	46.65	37.6	17.17	58.93	100	0	P	V
		15930	43.22	-30.78	74	39.24	41.08	19.84	56.94	100	0	P	V
													V
Remark	1. No other spurious found.												
	2. All results are PASS against Peak and Average limit line.												



Band 2 5250~5350MHz
WIFI 802.11ac VHT80 (Band Edge @ 3m)

WIFI	Note	Frequency	Level	Over	Limit	Read	Antenna	Cable	Preamp	Ant	Table	Peak	Pol.
Ant.				Limit	Line	Level	Factor	Loss	Factor	Pos	Pos	Avg.	
1+2		(MHz)	(dBμV/m)	(dB)	(dBμV/m)	(dBμV)	(dB/m)	(dB)	(dB)	(cm)	(deg)	(P/A)	(H/V)
802.11ac VHT80 CH 58 5290MHz		5149.5	52.61	-21.39	74	41.96	34.66	11.21	35.22	222	271	P	H
		5149.76	44.99	-9.01	54	34.34	34.66	11.21	35.22	222	271	A	H
	*	5290	99.99	-	-	88.73	34.98	11.51	35.23	222	271	P	H
	*	5290	92.14	-	-	80.88	34.98	11.51	35.23	222	271	A	H
		5384.16	57.46	-16.54	74	45.58	35.22	11.89	35.23	222	271	P	H
		5360.88	50.61	-3.39	54	38.9	35.18	11.76	35.23	222	271	A	H
		5140.14	52.79	-21.21	74	42.14	34.66	11.21	35.22	325	171	P	V
		5135.98	46.03	-7.97	54	35.45	34.62	11.18	35.22	325	171	A	V
	*	5290	100.56	-	-	89.3	34.98	11.51	35.23	325	171	P	V
	*	5290	93.39	-	-	82.13	34.98	11.51	35.23	325	171	A	V
		5383.68	57.66	-16.34	74	45.78	35.22	11.89	35.23	325	171	P	V
	5363.76	50.96	-3.04	54	39.25	35.18	11.76	35.23	325	171	A	V	
Remark	1. No other spurious found. 2. All results are PASS against Peak and Average limit line.												



Band 2 5250~5350MHz
WIFI 802.11ac VHT80 (Harmonic @ 3m)

WIFI	Note	Frequency	Level	Over	Limit	Read	Antenna	Cable	Preamp	Ant	Table	Peak	Pol.	
Ant.				Limit	Line	Level	Factor	Loss	Factor	Pos	Pos	Avg.		
1+2		(MHz)	(dBμV/m)	(dB)	(dBμV/m)	(dBμV)	(dB/m)	(dB)	(dB)	(cm)	(deg)	(P/A)	(H/V)	
802.11ac VHT80 CH 58 5290MHz		10580	42.36	-31.64	74	46.6	37.57	17.17	58.98	100	0	P	H	
		15870	44.03	-29.97	74	40.2	40.98	19.82	56.97	100	0	P	H	
													H	
													H	
			10580	42	-32	74	46.24	37.57	17.17	58.98	100	0	P	V
			15870	43.15	-30.85	74	39.32	40.98	19.82	56.97	100	0	P	V
														V
													V	
Remark	1. No other spurious found. 2. All results are PASS against Peak and Average limit line.													



Band 3 - 5470~5725MHz
WIFI 802.11a (Band Edge @ 3m)

WIFI Ant. 1+2	Note	Frequency (MHz)	Level (dBμV/m)	Over Limit (dB)	Limit Line (dBμV/m)	Read Level (dBμV)	Antenna Factor (dB/m)	Cable Loss (dB)	Preamp Factor (dB)	Ant Pos (cm)	Table Pos (deg)	Peak Avg. (P/A)	Pol. (H/V)	
802.11a CH 100 5500MHz		5461.52	52.51	-21.49	74	40.48	35.38	11.89	35.24	250	287	P	H	
		5470	44.44	-9.56	54	32.37	35.42	11.89	35.24	250	287	A	H	
	*	5500	107.93	-	-	95.78	35.5	11.89	35.24	250	287	P	H	
	*	5500	101.1	-	-	88.95	35.5	11.89	35.24	250	287	A	H	
													H	
														H
			5464.08	51.26	-22.74	74	39.19	35.42	11.89	35.24	339	186	P	V
			5470	42.58	-11.42	54	30.51	35.42	11.89	35.24	339	186	A	V
	*		5500	104.21	-	-	92.06	35.5	11.89	35.24	339	186	P	V
	*		5500	96.37	-	-	84.22	35.5	11.89	35.24	339	186	A	V
														V
														V
802.11a CH 116 5580MHz		5453.44	50.18	-23.82	74	38.15	35.38	11.89	35.24	271	288	P	H	
		5461.36	41.9	-12.1	54	29.87	35.38	11.89	35.24	271	288	A	H	
	*	5580	107.24	-	-	95.1	35.51	11.89	35.26	271	288	P	H	
	*	5580	100.86	-	-	88.72	35.51	11.89	35.26	271	288	A	H	
			5737.35	50.39	-23.61	74	38.07	35.55	12.06	35.29	271	288	P	H
			5733.5	42.4	-11.6	54	30.09	35.54	12.06	35.29	271	288	A	H
			5444.32	49.58	-24.42	74	37.59	35.34	11.89	35.24	318	166	P	V
			5464	41.63	-12.37	54	29.56	35.42	11.89	35.24	318	166	A	V
	*		5580	104.52	-	-	92.38	35.51	11.89	35.26	318	166	P	V
	*		5580	97.31	-	-	85.17	35.51	11.89	35.26	318	166	A	V
			5753.45	50.78	-23.22	74	38.41	35.55	12.11	35.29	318	166	P	V
			5727.2	42.27	-11.73	54	29.96	35.54	12.06	35.29	318	166	A	V



802.11a CH 140 5700MHz	*	5700	106.9	-	-	94.64	35.54	12	35.28	249	286	P	H
	*	5700	99.77	-	-	87.51	35.54	12	35.28	249	286	A	H
		5748.2	52.5	-21.5	74	40.13	35.55	12.11	35.29	249	286	P	H
		5727.8	44.46	-9.54	54	32.15	35.54	12.06	35.29	249	286	A	H
													H
													H
	*	5700	103.28	-	-	91.02	35.54	12	35.28	300	184	P	V
	*	5700	96.72	-	-	84.46	35.54	12	35.28	300	184	A	V
		5735.88	51.89	-22.11	74	39.57	35.55	12.06	35.29	300	184	P	V
		5725.24	43.49	-10.51	54	31.18	35.54	12.06	35.29	300	184	A	V
													V
													V
Remark	1. No other spurious found. 2. All results are PASS against Peak and Average limit line.												



Band 3 - 5470~5725MHz
WIFI 802.11a (Harmonic @ 3m)

WIFI	Note	Frequency	Level	Over	Limit	Read	Antenna	Cable	Preamp	Ant	Table	Peak	Pol.
Ant.				Limit	Line	Level	Factor	Loss	Factor	Pos	Pos	Avg.	
1+2		(MHz)	(dBμV/m)	(dB)	(dBμV/m)	(dBμV)	(dB/m)	(dB)	(dB)	(cm)	(deg)	(P/A)	(H/V)
802.11a CH 100 5500MHz		11000	43.91	-30.09	74	47.24	37.9	17.17	58.4	100	0	P	H
		16500	45.86	-28.14	74	40.13	41.6	20.23	56.1	100	0	P	H
													H
													H
		11000	43.65	-30.35	74	46.98	37.9	17.17	58.4	100	0	P	V
		16500	44.93	-29.07	74	39.2	41.6	20.23	56.1	100	0	P	V
													V
													V
802.11a CH 116 5580MHz		11160	42.95	-31.05	74	45.75	38.07	17.16	58.03	100	0	P	H
		16740	45	-29	74	38.68	41.89	20.39	55.96	100	0	P	H
													H
													H
		11160	43	-31	74	45.8	38.07	17.16	58.03	100	0	P	V
		16740	45.4	-28.6	74	39.08	41.89	20.39	55.96	100	0	P	V
													V
													V
802.11a CH 140 5700MHz		11400	42.18	-31.82	74	44.24	38.3	17.16	57.52	100	0	P	H
		17100	46.98	-27.02	74	40.03	42.14	20.65	55.84	100	0	P	H
													H
													H
		11400	42.65	-31.35	74	44.71	38.3	17.16	57.52	100	0	P	V
		17100	45.97	-28.03	74	39.02	42.14	20.65	55.84	100	0	P	V
													V
													V
Remark	1. No other spurious found. 2. All results are PASS against Peak and Average limit line.												



Band 3 - 5470~5725MHz
WIFI 802.11ac VHT20 (Band Edge @ 3m)

WIFI	Note	Frequency	Level	Over	Limit	Read	Antenna	Cable	Preamp	Ant	Table	Peak	Pol.	
Ant.				Limit	Line	Level	Factor	Loss	Factor	Pos	Pos	Avg.		
1+2		(MHz)	(dBμV/m)	(dB)	(dBμV/m)	(dBμV)	(dB/m)	(dB)	(dB)	(cm)	(deg)	(P/A)	(H/V)	
802.11ac VHT20 CH 100 5500MHz		5464.24	52.39	-21.61	74	40.32	35.42	11.89	35.24	100	281	P	H	
		5469.84	45.56	-8.44	54	33.49	35.42	11.89	35.24	100	281	A	H	
	*	5500	107.3	-	-	95.15	35.5	11.89	35.24	100	281	P	H	
	*	5500	98.49	-	-	86.34	35.5	11.89	35.24	100	281	A	H	
													H	
														H
			5465.36	51.23	-22.77	74	39.16	35.42	11.89	35.24	276	184	P	V
			5468.72	44.79	-9.21	54	32.72	35.42	11.89	35.24	276	184	A	V
	*		5500	104.98	-	-	92.83	35.5	11.89	35.24	276	184	P	V
	*		5500	97.52	-	-	85.37	35.5	11.89	35.24	276	184	A	V
													V	
													V	
802.11ac VHT20 CH 116 5580MHz		5438.32	49.96	-24.04	74	37.97	35.34	11.89	35.24	101	281	P	H	
		5460.64	42.23	-11.77	54	30.2	35.38	11.89	35.24	101	281	A	H	
	*	5580	107.45	-	-	95.31	35.51	11.89	35.26	101	281	P	H	
	*	5580	98.66	-	-	86.52	35.51	11.89	35.26	101	281	A	H	
			5732.1	51.28	-22.72	74	38.97	35.54	12.06	35.29	101	281	P	H
			5731.05	42.6	-11.4	54	30.29	35.54	12.06	35.29	101	281	A	H
			5387.2	49.85	-24.15	74	37.97	35.22	11.89	35.23	257	186	P	V
			5466.4	42.06	-11.94	54	29.99	35.42	11.89	35.24	257	186	A	V
	*		5580	104.75	-	-	92.61	35.51	11.89	35.26	257	186	P	V
	*		5580	97.26	-	-	85.12	35.51	11.89	35.26	257	186	A	V
		5733.85	52.1	-21.9	74	39.79	35.54	12.06	35.29	257	186	P	V	
		5757.125	42.6	-11.4	54	30.23	35.55	12.11	35.29	257	186	A	V	



802.11ac VHT20 CH 140 5700MHz	*	5700	105.51	-	-	93.25	35.54	12	35.28	104	280	P	H
	*	5700	95.26	-	-	83	35.54	12	35.28	104	280	A	H
		5726.68	52.06	-21.94	74	39.75	35.54	12.06	35.29	104	280	P	H
		5729.88	44.5	-9.5	54	32.19	35.54	12.06	35.29	104	280	A	H
													H
													H
	*	5700	104.94	-	-	92.68	35.54	12	35.28	258	187	P	V
	*	5700	96.98	-	-	84.72	35.54	12	35.28	258	187	A	V
		5730.44	52.8	-21.2	74	40.49	35.54	12.06	35.29	258	187	P	V
		5725.64	45.08	-8.92	54	32.77	35.54	12.06	35.29	258	187	A	V
												V	
												V	
Remark	1. No other spurious found. 2. All results are PASS against Peak and Average limit line.												



Band 3 - 5470~5725MHz
WIFI 802.11ac VHT20 (Harmonic @ 3m)

WIFI	Note	Frequency	Level	Over	Limit	Read	Antenna	Cable	Preamp	Ant	Table	Peak	Pol.
Ant.				Limit	Line	Level	Factor	Loss	Factor	Pos	Pos	Avg.	
1+2		(MHz)	(dBμV/m)	(dB)	(dBμV/m)	(dBμV)	(dB/m)	(dB)	(dB)	(cm)	(deg)	(P/A)	(H/V)
802.11ac VHT20 CH 100 5500MHz		11000	43.67	-30.33	74	47	37.9	17.17	58.4	100	0	P	H
		16500	46	-28	74	40.27	41.6	20.23	56.1	100	0	P	H
													H
													H
		11000	43.9	-30.1	74	47.23	37.9	17.17	58.4	100	0	P	V
		16500	45.64	-28.36	74	39.91	41.6	20.23	56.1	100	0	P	V
802.11ac VHT20 CH 116 5580MHz		11160	43	-31	74	45.8	38.07	17.16	58.03	100	0	P	H
		16740	44.71	-29.29	74	38.39	41.89	20.39	55.96	100	0	P	H
													H
													H
		11160	43.77	-30.23	74	46.57	38.07	17.16	58.03	100	0	P	V
		16740	45.13	-28.87	74	38.81	41.89	20.39	55.96	100	0	P	V
802.11ac VHT20 CH 140 5700MHz		11400	43.01	-30.99	74	45.07	38.3	17.16	57.52	100	0	P	H
		17100	46.2	-27.8	74	39.25	42.14	20.65	55.84	100	0	P	H
													H
													H
		11400	43.6	-30.4	74	45.66	38.3	17.16	57.52	100	0	P	V
		17100	46	-28	74	39.05	42.14	20.65	55.84	100	0	P	V
Remark	1. No other spurious found.												
	2. All results are PASS against Peak and Average limit line.												



Band 3 - 5470~5725MHz
WIFI 802.11ac VHT40 (Band Edge @ 3m)

WIFI	Note	Frequency	Level	Over	Limit	Read	Antenna	Cable	Preamp	Ant	Table	Peak	Pol.
Ant.				Limit	Line	Level	Factor	Loss	Factor	Pos	Pos	Avg.	
1+2		(MHz)	(dBμV/m)	(dB)	(dBμV/m)	(dBμV)	(dB/m)	(dB)	(dB)	(cm)	(deg)	(P/A)	(H/V)
802.11ac VHT40 CH 102 5510MHz		5458.96	55.05	-18.95	74	43.02	35.38	11.89	35.24	104	300	P	H
		5469.04	62.4	-5.9	68.3	50.33	35.42	11.89	35.24	104	300	P	H
		5459.92	49.7	-4.3	54	37.67	35.38	11.89	35.24	104	300	A	H
	*	5510	104.73	-	-	92.58	35.5	11.89	35.24	104	300	P	H
	*	5510	95.57	-	-	83.42	35.5	11.89	35.24	104	300	A	H
		5751.7	51.49	-16.81	68.3	39.12	35.55	12.11	35.29	104	300	P	H
		5458.72	58.32	-15.68	74	46.29	35.38	11.89	35.24	300	175	P	V
		5464.72	60.46	-7.84	68.3	48.39	35.42	11.89	35.24	300	175	P	V
		5459.68	48.59	-5.41	54	36.56	35.38	11.89	35.24	300	175	A	V
	*	5510	101.47	-	-	89.32	35.5	11.89	35.24	300	175	P	V
	*	5510	93.5	-	-	81.35	35.5	11.89	35.24	300	175	A	V
		5763.075	50.45	-17.85	68.3	38.08	35.55	12.11	35.29	300	175	P	V
802.11ac VHT40 CH 110 5550MHz		5469.76	53.24	-20.76	74	41.17	35.42	11.89	35.24	100	280	P	H
		5468.32	45.17	-8.83	54	33.1	35.42	11.89	35.24	100	280	A	H
	*	5550	104.77	-	-	92.62	35.51	11.89	35.25	100	280	P	H
	*	5550	95.91	-	-	83.76	35.51	11.89	35.25	100	280	A	H
		5743.475	51.19	-22.81	74	38.82	35.55	12.11	35.29	100	280	P	H
		5727.375	42.52	-11.48	54	30.21	35.54	12.06	35.29	100	280	A	H
		5467.36	50.62	-23.38	74	38.55	35.42	11.89	35.24	270	186	P	V
		5470	44.38	-9.62	54	32.31	35.42	11.89	35.24	270	186	A	V
	*	5550	102.66	-	-	90.51	35.51	11.89	35.25	270	186	P	V
	*	5550	94.85	-	-	82.7	35.51	11.89	35.25	270	186	A	V
	5731.225	51.38	-22.62	74	39.07	35.54	12.06	35.29	270	186	P	V	
	5763.775	42.75	-11.25	54	30.38	35.55	12.11	35.29	270	186	A	V	



802.11ac VHT40 CH 134 5670MHz		5465.2	49.74	-24.26	74	37.67	35.42	11.89	35.24	100	300	P	H
		5466.4	42.33	-11.67	54	30.26	35.42	11.89	35.24	100	300	A	H
	*	5670	101.76	-	-	89.5	35.53	12	35.27	100	300	P	H
	*	5670	93.24	-	-	80.98	35.53	12	35.27	100	300	A	H
		5725.625	53.25	-20.75	74	40.94	35.54	12.06	35.29	100	300	P	H
		5728.25	44.87	-9.13	54	32.56	35.54	12.06	35.29	100	300	A	H
		5466.64	51.07	-22.93	74	39	35.42	11.89	35.24	300	197	P	V
		5459.44	41.99	-12.01	54	29.96	35.38	11.89	35.24	300	197	A	V
	*	5670	100.37	-	-	88.11	35.53	12	35.27	300	197	P	V
	*	5670	92.46	-	-	80.2	35.53	12	35.27	300	197	A	V
		5729.825	52.75	-21.25	74	40.44	35.54	12.06	35.29	300	197	P	V
	5728.425	44.37	-9.63	54	32.06	35.54	12.06	35.29	300	197	A	V	
Remark	1. No other spurious found. 2. All results are PASS against Peak and Average limit line.												



Band 3 - 5470~5725MHz
WIFI 802.11ac VHT40 (Harmonic @ 3m)

WIFI	Note	Frequency	Level	Over	Limit	Read	Antenna	Cable	Preamp	Ant	Table	Peak	Pol.
Ant.				Limit	Line	Level	Factor	Loss	Factor	Pos	Pos	Avg.	
1+2		(MHz)	(dBμV/m)	(dB)	(dBμV/m)	(dBμV)	(dB/m)	(dB)	(dB)	(cm)	(deg)	(P/A)	(H/V)
802.11ac VHT40 CH 102 5510MHz		11020	42.75	-31.25	74	46.02	37.92	17.17	58.36	100	0	P	H
		16530	44.98	-23.32	68.3	39.17	41.64	20.25	56.08	100	0	P	H
													H
													H
		11020	43.01	-30.99	74	46.28	37.92	17.17	58.36	100	0	P	V
		16530	45.09	-23.21	68.3	39.28	41.64	20.25	56.08	100	0	P	V
802.11ac VHT40 CH 110 5550MHz		11100	43.5	-30.5	74	46.52	38	17.16	58.18	100	0	P	H
		16650	45.77	-28.23	74	39.65	41.79	20.34	56.01	100	0	P	H
													H
													H
		11100	42.69	-31.31	74	45.71	38	17.16	58.18	100	0	P	V
		16650	46.06	-27.94	74	39.94	41.79	20.34	56.01	100	0	P	V
802.11ac VHT40 CH 134 5670MHz		11340	42.76	-31.24	74	45.04	38.23	17.16	57.67	100	0	P	H
		17010	46.69	-27.31	74	39.72	42.19	20.59	55.81	100	0	P	H
													H
													H
		11340	42.36	-31.64	74	44.64	38.23	17.16	57.67	100	0	P	V
		17010	46.52	-27.48	74	39.55	42.19	20.59	55.81	100	0	P	V
Remark	1. No other spurious found.												
	2. All results are PASS against Peak and Average limit line.												



Band 3 5470~5725MHz
WIFI 802.11ac VHT80 (Band Edge @ 3m)

WIFI	Note	Frequency	Level	Over	Limit	Read	Antenna	Cable	Preamp	Ant	Table	Peak	Pol.
Ant.				Limit	Line	Level	Factor	Loss	Factor	Pos	Pos	Avg.	
1+2		(MHz)	(dBμV/m)	(dB)	(dBμV/m)	(dBμV)	(dB/m)	(dB)	(dB)	(cm)	(deg)	(P/A)	(H/V)
802.11ac VHT80 CH 106 5530MHz		5446.72	57.71	-16.29	74	45.68	35.38	11.89	35.24	100	297	P	H
		5468.8	58.43	-9.87	68.3	46.36	35.42	11.89	35.24	100	297	P	H
		5441.2	52.18	-1.82	54	40.19	35.34	11.89	35.24	100	297	A	H
	*	5530	98.43	-	-	86.29	35.5	11.89	35.25	100	297	P	H
	*	5530	90.06	-	-	77.92	35.5	11.89	35.25	100	297	A	H
		5751.875	51.29	-17.01	68.3	38.92	35.55	12.11	35.29	100	297	P	H
		5438.08	57.15	-16.85	74	45.16	35.34	11.89	35.24	284	197	P	V
		5462.32	56.03	-12.27	68.3	44	35.38	11.89	35.24	284	197	P	V
		5459.68	50.4	-3.6	54	38.37	35.38	11.89	35.24	284	197	A	V
	*	5530	97.04	-	-	84.9	35.5	11.89	35.25	284	197	P	V
	*	5530	89.42	-	-	77.28	35.5	11.89	35.25	284	197	A	V
		5734.025	51.61	-16.69	68.3	39.3	35.54	12.06	35.29	284	197	P	V
802.11ac VHT80 CH 122 5610MHz		5454.88	52.98	-21.02	74	40.95	35.38	11.89	35.24	100	297	P	H
		5463.76	51.47	-16.83	68.3	39.4	35.42	11.89	35.24	100	297	P	H
		5454.64	44.18	-9.82	54	32.15	35.38	11.89	35.24	100	297	A	H
	*	5610	97.82	-	-	85.67	35.52	11.89	35.26	100	297	P	H
	*	5610	89.99	-	-	77.84	35.52	11.89	35.26	100	297	A	H
		5745.925	51.3	-17	68.3	38.93	35.55	12.11	35.29	100	297	P	H
		5447.68	52.65	-21.35	74	40.62	35.38	11.89	35.24	317	197	P	V
		5469.04	51.31	-16.99	68.3	39.24	35.42	11.89	35.24	317	197	P	V
		5458.48	44.55	-9.45	54	32.52	35.38	11.89	35.24	317	197	A	V
	*	5610	95.91	-	-	83.76	35.52	11.89	35.26	317	197	P	V
	*	5610	87.83	-	-	75.68	35.52	11.89	35.26	317	197	A	V
		5725.625	51.51	-16.79	68.3	39.2	35.54	12.06	35.29	317	197	P	V
Remark	1. No other spurious found. 2. All results are PASS against Peak and Average limit line.												



Band 3 5470~5725MHz
WIFI 802.11ac VHT80 (Harmonic @ 3m)

WIFI	Note	Frequency	Level	Over	Limit	Read	Antenna	Cable	Preamp	Ant	Table	Peak	Pol.
Ant.				Limit	Line	Level	Factor	Loss	Factor	Pos	Pos	Avg.	
1+2		(MHz)	(dBμV/m)	(dB)	(dBμV/m)	(dBμV)	(dB/m)	(dB)	(dB)	(cm)	(deg)	(P/A)	(H/V)
802.11ac VHT80 CH 106 5530MHz		11060	42.57	-31.43	74	45.69	37.97	17.16	58.25	100	0	P	H
		16590	44.97	-29.03	68.3	39.01	41.7	20.31	56.05	100	0	P	H
													H
													H
		11060	43.36	-30.64	74	46.48	37.97	17.16	58.25	100	0	P	V
		16590	44.98	-29.02	68.3	39.02	41.7	20.31	56.05	100	0	P	V
													V
802.11ac VHT80 CH 122 5610MHz		11220	42.51	-31.49	74	45.15	38.12	17.16	57.92	100	0	P	H
		16830	46.39	-27.61	68.3	39.82	41.99	20.48	55.9	100	0	P	H
													H
													H
		11220	42.07	-31.93	74	44.71	38.12	17.16	57.92	100	0	P	V
		16830	46.42	-27.58	68.3	39.85	41.99	20.48	55.9	100	0	P	V
													V
Remark	1. No other spurious found.												
	2. All results are PASS against Peak and Average limit line.												



Band 3 - Straddle Channel
WIFI 802.11a (Band Edge @ 3m)

WIFI Ant. 1+2	Note	Frequency (MHz)	Level (dBμV/m)	Over Limit (dB)	Limit Line (dBμV/m)	Read Level (dBμV)	Antenna Factor (dB/m)	Cable Loss (dB)	Preamp Factor (dB)	Ant Pos (cm)	Table Pos (deg)	Peak Avg. (P/A)	Pol. (H/V)
802.11a CH 144 5720MHz	*	5720	102.59	-	-	90.27	35.54	12.06	35.28	100	299	P	H
	*	5720	94.85	-	-	82.53	35.54	12.06	35.28	100	299	A	H
													H
													H
													H
	*	5720	101.64	-	-	89.32	35.54	12.06	35.28	318	167	P	V
	*	5720	94.25	-	-	81.93	35.54	12.06	35.28	318	167	A	V
													V
													V
													V
													V
Remark	1. No other spurious found. 2. All results are PASS against Peak and Average limit line.												



Band 3 - Straddle Channel
WIFI 802.11a (Harmonic @ 3m)

WIFI	Note	Frequency	Level	Over	Limit	Read	Antenna	Cable	Preamp	Ant	Table	Peak	Pol.
Ant.				Limit	Line	Level	Factor	Loss	Factor	Pos	Pos	Avg.	
1+2		(MHz)	(dBμV/m)	(dB)	(dBμV/m)	(dBμV)	(dB/m)	(dB)	(dB)	(cm)	(deg)	(P/A)	(H/V)
802.11a CH 144 5720MHz		11440	43.04	-30.96	74	45	38.33	17.16	57.45	100	0	P	H
		17160	46.22	-27.78	74	39.29	42.1	20.7	55.87	100	0	P	H
													H
													H
		11440	43.52	-30.48	74	45.48	38.33	17.16	57.45	100	0	P	V
		17160	46.38	-27.62	74	39.45	42.1	20.7	55.87	100	0	P	V
													V
													V
Remark	1. No other spurious found. 2. All results are PASS against Peak and Average limit line.												



Band 3 - Straddle Channel
WIFI 802.11ac VHT20 (Band Edge @ 3m)

WIFI	Note	Frequency	Level	Over	Limit	Read	Antenna	Cable	Preamp	Ant	Table	Peak	Pol.
Ant.				Limit	Line	Level	Factor	Loss	Factor	Pos	Pos	Avg.	
1+2		(MHz)	(dBμV/m)	(dB)	(dBμV/m)	(dBμV)	(dB/m)	(dB)	(dB)	(cm)	(deg)	(P/A)	(H/V)
802.11ac VHT20 CH 144 5720MHz	*	5720	101.42	-	-	89.1	35.54	12.06	35.28	100	300	P	H
	*	5720	92.46	-	-	80.14	35.54	12.06	35.28	100	300	A	H
													H
													H
													H
													H
	*	5720	99.13	-	-	86.81	35.54	12.06	35.28	260	169	P	V
	*	5720	91.52	-	-	79.2	35.54	12.06	35.28	260	169	A	V
													V
													V
												V	
												V	
Remark	1. No other spurious found. 2. All results are PASS against Peak and Average limit line.												



Band 3 - Straddle Channel
WIFI 802.11ac VHT20 (Harmonic @ 3m)

WIFI	Note	Frequency	Level	Over	Limit	Read	Antenna	Cable	Preamp	Ant	Table	Peak	Pol.	
Ant.				Limit	Line	Level	Factor	Loss	Factor	Pos	Pos	Avg.		
1+2		(MHz)	(dBμV/m)	(dB)	(dBμV/m)	(dBμV)	(dB/m)	(dB)	(dB)	(cm)	(deg)	(P/A)	(H/V)	
802.11ac VHT20 CH 144 5720MHz		11440	42.99	-31.01	74	44.95	38.33	17.16	57.45	100	0	P	H	
		17160	47.28	-26.72	74	40.35	42.1	20.7	55.87	100	0	P	H	
													H	
													H	
			11440	42.99	-31.01	74	44.95	38.33	17.16	57.45	100	0	P	V
			17160	46.19	-27.81	74	39.26	42.1	20.7	55.87	100	0	P	V
														V
Remark	1. No other spurious found. 2. All results are PASS against Peak and Average limit line.													



Band 3 - Straddle Channel
WIFI 802.11ac VHT40 (Band Edge @ 3m)

WIFI	Note	Frequency	Level	Over	Limit	Read	Antenna	Cable	Preamp	Ant	Table	Peak	Pol.
Ant.				Limit	Line	Level	Factor	Loss	Factor	Pos	Pos	Avg.	
1+2		(MHz)	(dBμV/m)	(dB)	(dBμV/m)	(dBμV)	(dB/m)	(dB)	(dB)	(cm)	(deg)	(P/A)	(H/V)
802.11ac VHT40 CH 142 5710MHz	*	5710	98.47	-	-	86.15	35.54	12.06	35.28	100	300	P	H
	*	5710	89.75	-	-	77.43	35.54	12.06	35.28	100	300	A	H
													H
													H
													H
													H
	*	5710	96.48	-	-	84.16	35.54	12.06	35.28	273	170	P	V
	*	5710	88.83	-	-	76.51	35.54	12.06	35.28	273	170	A	V
													V
													V
												V	
												V	
Remark	1. No other spurious found. 2. All results are PASS against Peak and Average limit line.												



Band 3 - Straddle Channel
WIFI 802.11ac VHT40 (Harmonic @ 3m)

WIFI	Note	Frequency	Level	Over	Limit	Read	Antenna	Cable	Preamp	Ant	Table	Peak	Pol.	
Ant.				Limit	Line	Level	Factor	Loss	Factor	Pos	Pos	Avg.		
1+2		(MHz)	(dBμV/m)	(dB)	(dBμV/m)	(dBμV)	(dB/m)	(dB)	(dB)	(cm)	(deg)	(P/A)	(H/V)	
802.11ac VHT40 CH 142 5710MHz		11420	43.57	-30.43	74	45.57	38.32	17.16	57.48	100	0	P	H	
		17130	46.55	-27.45	74	39.61	42.12	20.67	55.85	100	0	P	H	
													H	
													H	
			11420	43.29	-30.71	74	45.29	38.32	17.16	57.48	100	0	P	V
			17130	46.73	-27.27	74	39.79	42.12	20.67	55.85	100	0	P	V
														V
Remark	1. No other spurious found. 2. All results are PASS against Peak and Average limit line.													



Band 3 - Straddle Channel
WIFI 802.11ac VHT80 (Band Edge @ 3m)

WIFI	Note	Frequency	Level	Over	Limit	Read	Antenna	Cable	Preamp	Ant	Table	Peak	Pol.
Ant.				Limit	Line	Level	Factor	Loss	Factor	Pos	Pos	Avg.	
1+2		(MHz)	(dBμV/m)	(dB)	(dBμV/m)	(dBμV)	(dB/m)	(dB)	(dB)	(cm)	(deg)	(P/A)	(H/V)
802.11ac VHT80 CH 138 5690MHz	*	5690	96.48	-	-	84.22	35.54	12	35.28	100	300	P	H
	*	5690	88.01	-	-	75.75	35.54	12	35.28	100	300	A	H
													H
													H
													H
													H
	*	5690	94.83	-	-	82.57	35.54	12	35.28	341	169	P	V
	*	5690	86.58	-	-	74.32	35.54	12	35.28	341	169	A	V
													V
													V
												V	
												V	
Remark	1. No other spurious found. 2. All results are PASS against Peak and Average limit line.												



**Band 3 - Straddle Channel
WIFI 802.11ac VHT80 (Harmonic @ 3m)**

WIFI	Note	Frequency	Level	Over	Limit	Read	Antenna	Cable	Preamp	Ant	Table	Peak	Pol.	
Ant.				Limit	Line	Level	Factor	Loss	Factor	Pos	Pos	Avg.		
1+2		(MHz)	(dBμV/m)	(dB)	(dBμV/m)	(dBμV)	(dB/m)	(dB)	(dB)	(cm)	(deg)	(P/A)	(H/V)	
802.11ac VHT80 CH 138 5690MHz		11380	43.47	-30.53	74	45.59	38.28	17.16	57.56	100	0	P	H	
		17070	46.92	-27.08	74	39.94	42.16	20.65	55.83	100	0	P	H	
													H	
													H	
			11380	43.02	-30.98	74	45.14	38.28	17.16	57.56	100	0	P	V
			17070	46.29	-27.71	74	39.31	42.16	20.65	55.83	100	0	P	V
														V
Remark	1. No other spurious found. 2. All results are PASS against Peak and Average limit line.													



Emission below 1GHz
WIFI 802.11a (LF @ 3m)

WIFI Ant. 1+2	Note	Frequency (MHz)	Level (dBµV/m)	Over Limit (dB)	Limit Line (dBµV/m)	Read Level (dBµV)	Antenna Factor (dB/m)	Cable Loss (dB)	Preamp Factor (dB)	Ant Pos (cm)	Table Pos (deg)	Peak Avg. (P/A)	Pol. (H/V)	
802.11a LF		70.77	25.44	-14.56	40	42.92	12.81	1.28	31.57	-	-	P	H	
		105.87	32.54	-10.96	43.5	45.57	16.94	1.55	31.52	-	-	P	H	
		240.06	37.62	-8.38	46	48.86	18.09	2.07	31.4	100	0	P	H	
		360.2	28.21	-17.79	46	35.48	21.44	2.5	31.21	-	-	P	H	
		659.8	37.33	-8.67	46	38.52	26	3.57	30.76	-	-	P	H	
		885.9	34.15	-11.85	46	31.62	28.91	4.17	30.55	-	-	P	H	
														H
														H
														H
														H
														H
														H
														H
														H
														H
			35.13	35.06	-4.94	40	42.1	23.3	1.07	31.41	100	0	P	V
			99.39	31.71	-11.79	43.5	45.55	16.4	1.28	31.52	-	-	P	V
		240.06	29.62	-16.38	46	40.86	18.09	2.07	31.4	-	-	P	V	
		527.5	27.2	-18.8	46	30.6	24.42	3.14	30.96	-	-	P	V	
		659.8	34.88	-11.12	46	36.07	26	3.57	30.76	-	-	P	V	
		839.7	33.99	-12.01	46	31.96	28.5	4.1	30.57	-	-	P	V	
													V	
													V	
													V	
													V	
													V	
													V	
													V	
Remark	1. No other spurious found. 2. All results are PASS against limit line.													



Emission below 1GHz
WIFI 802.11ac VHT20 (LF @ 3m)

WIFI Ant. 1+2	Note	Frequency (MHz)	Level (dBμV/m)	Over Limit (dB)	Limit Line (dBμV/m)	Read Level (dBμV)	Antenna Factor (dB/m)	Cable Loss (dB)	Preamp Factor (dB)	Ant Pos (cm)	Table Pos (deg)	Peak Avg. (P/A)	Pol. (H/V)	
802.11ac VHT20 LF		88.59	32.41	-11.09	43.5	47.81	14.86	1.28	31.54	-	-	P	H	
		108.03	33.1	-10.4	43.5	45.95	17.12	1.55	31.52	-	-	P	H	
		240.06	37.83	-8.17	46	49.07	18.09	2.07	31.4	-	-	P	H	
		300	29.85	-16.15	46	39	19.8	2.32	31.27	-	-	P	H	
		659.8	37.85	-8.15	46	39.04	26	3.57	30.76	-	-	P	H	
		780.2	37.91	-8.09	46	37.13	27.5	3.9	30.62	100	0	P	H	
														H
														H
														H
														H
														H
														H
			38.91	32.88	-7.12	40	42.29	20.98	1.07	31.46	100	0	P	V
			101.82	31.34	-12.16	43.5	44.73	16.58	1.55	31.52	-	-	P	V
			240.06	29.4	-16.6	46	40.64	18.09	2.07	31.4	-	-	P	V
			486.9	26.93	-19.07	46	31.03	23.9	3.04	31.04	-	-	P	V
			659.8	34.87	-11.13	46	36.06	26	3.57	30.76	-	-	P	V
			951	33.8	-12.2	46	30.06	30.2	4.07	30.53	-	-	P	V
														V
														V
													V	
													V	
													V	
Remark	1. No other spurious found. 2. All results are PASS against limit line.													



Emission below 1GHz
WIFI 802.11ac VHT40 (LF @ 3m)

WIFI Ant. 1+2	Note	Frequency (MHz)	Level (dBμV/m)	Over Limit (dB)	Limit Line (dBμV/m)	Read Level (dBμV)	Antenna Factor (dB/m)	Cable Loss (dB)	Preamp Factor (dB)	Ant Pos (cm)	Table Pos (deg)	Peak Avg. (P/A)	Pol. (H/V)	
802.11ac VHT40 LF		30	28.98	-11.02	40	33.26	26	1.07	31.35	-	-	P	H	
		106.95	31.22	-12.28	43.5	44.16	17.03	1.55	31.52	-	-	P	H	
		240.06	37.7	-8.3	46	48.94	18.09	2.07	31.4	-	-	P	H	
		300	29.14	-16.86	46	38.29	19.8	2.32	31.27	-	-	P	H	
		659.8	37	-9	46	38.19	26	3.57	30.76	100	0	P	H	
		899.9	34.36	-11.64	46	31.73	29	4.17	30.54	-	-	P	H	
														H
														H
														H
														H
														H
														H
			35.94	29.28	-10.72	40	36.92	22.72	1.07	31.43	100	0	P	V
			100.47	29.5	-14	43.5	42.98	16.49	1.55	31.52	-	-	P	V
			240.06	29.78	-16.22	46	41.02	18.09	2.07	31.4	-	-	P	V
			479.9	26.09	-19.91	46	30.34	23.76	3.04	31.05	-	-	P	V
			659.8	34.95	-11.05	46	36.14	26	3.57	30.76	-	-	P	V
			972.7	34.52	-19.48	54	30.73	30.25	4.07	30.53	-	-	P	V
														V
														V
													V	
													V	
													V	
													V	
Remark	1. No other spurious found. 2. All results are PASS against limit line.													



Emission below 1GHz
WIFI 802.11ac VHT80 (LF @ 3m)

WIFI Ant. 1+2	Note	Frequency (MHz)	Level (dBμV/m)	Over Limit (dB)	Limit Line (dBμV/m)	Read Level (dBμV)	Antenna Factor (dB/m)	Cable Loss (dB)	Preamp Factor (dB)	Ant Pos (cm)	Table Pos (deg)	Peak Avg. (P/A)	Pol. (H/V)	
802.11ac VHT80 LF		89.4	31.53	-11.97	43.5	46.81	14.98	1.28	31.54	-	-	P	H	
		193.08	24.03	-19.47	43.5	37.99	15.65	1.87	31.48	-	-	P	H	
		240.06	37.74	-8.26	46	48.98	18.09	2.07	31.4	-	-	P	H	
		300	29.18	-16.82	46	38.33	19.8	2.32	31.27	-	-	P	H	
		659.8	36.71	-9.29	46	37.9	26	3.57	30.76	-	-	P	H	
		780.2	37.47	-8.53	46	36.69	27.5	3.9	30.62	100	0	P	H	
														H
														H
														H
														H
														H
														H
			34.59	33.33	-6.67	40	40.37	23.3	1.07	31.41	100	0	P	V
			105.33	29.71	-13.79	43.5	42.74	16.94	1.55	31.52	-	-	P	V
			240.06	28.91	-17.09	46	40.15	18.09	2.07	31.4	-	-	P	V
			465.9	26.59	-19.41	46	31.18	23.44	3.04	31.07	-	-	P	V
			659.8	34.61	-11.39	46	35.8	26	3.57	30.76	-	-	P	V
			780.2	33.7	-12.3	46	32.92	27.5	3.9	30.62	-	-	P	V
														V
														V
													V	
													V	
													V	
													V	
Remark	1. No other spurious found. 2. All results are PASS against limit line.													



Note symbol

*	Fundamental Frequency which can be ignored. However, the level of any unwanted emissions shall not exceed the level of the fundamental frequency.
!	Test result is over limit line.
P/A	Peak or Average
H/V	Horizontal or Vertical



A calculation example for radiated spurious emission is shown as below:

WIFI Ant. 1+2	Note	Frequency (MHz)	Level (dBμV/m)	Over Limit (dB)	Limit Line (dBμV/m)	Read Level (dBμV)	Antenna Factor (dB/m)	Cable Loss (dB)	Preamp Factor (dB)	Ant Pos (cm)	Table Pos (deg)	Peak Avg. (P/A)	Pol. (H/V)
802.11b		2390	55.45	-18.55	74	54.51	32.22	4.58	35.86	103	308	P	H
CH 01		2390	43.54	-10.46	54	42.6	32.22	4.58	35.86	103	308	A	H
2412MHz													

- 1. Level(dBμV/m) =
Antenna Factor(dB/m) + Cable Loss(dB) + Read Level(dBμV) - Preamp Factor(dB)
- 2. Over Limit(dB) = Level(dBμV/m) – Limit Line(dBμV/m)

For Peak Limit @ 2390MHz:

- 1. Level(dBμV/m)
= Antenna Factor(dB/m) + Cable Loss(dB) + Read Level(dBμV) - Preamp Factor(dB)
= 32.22(dB/m) + 4.58(dB) + 54.51(dBμV) – 35.86 (dB)
= 55.45 (dBμV/m)
- 2. Over Limit(dB)
= Level(dBμV/m) – Limit Line(dBμV/m)
= 55.45(dBμV/m) – 74(dBμV/m)
= -18.55(dB)

For Average Limit @ 2390MHz:

- 1. Level(dBμV/m)
= Antenna Factor(dB/m) + Cable Loss(dB) + Read Level(dBμV) - Preamp Factor(dB)
= 32.22(dB/m) + 4.58(dB) + 42.6(dBμV) – 35.86 (dB)
= 43.54 (dBμV/m)
- 2. Over Limit(dB)
= Level(dBμV/m) – Limit Line(dBμV/m)
= 43.54(dBμV/m) – 54(dBμV/m)
= -10.46(dB)

Both peak and average measured complies with the limit line, so test result is “PASS”.



<TXBF Mode>

Band 1 - 5150~5250MHz

WIFI 802.11a (Band Edge @ 3m)

WIFI	Note	Frequency	Level	Over	Limit	Read	Antenna	Cable	Preamp	Ant	Table	Peak	Pol.	
Ant.				Limit	Line	Level	Factor	Loss	Factor	Pos	Pos	Avg.		
1+2		(MHz)	(dBμV/m)	(dB)	(dBμV/m)	(dBμV)	(dB/m)	(dB)	(dB)	(cm)	(deg)	(P/A)	(H/V)	
802.11a CH 36 5180MHz		5149.24	53.69	-20.31	74	43.04	34.66	11.21	35.22	102	276	P	H	
		5150	47.02	-6.98	54	36.37	34.66	11.21	35.22	102	276	A	H	
	*	5180	109.57	-	-	98.84	34.74	11.21	35.22	102	276	P	H	
	*	5180	102.68	-	-	91.95	34.74	11.21	35.22	102	276	A	H	
													H	
														H
			5080.08	51.44	-22.56	74	41.01	34.5	11.14	35.21	300	176	P	V
			5150	43.58	-10.42	54	32.93	34.66	11.21	35.22	300	176	A	V
	*		5180	105.05	-	-	94.32	34.74	11.21	35.22	300	176	P	V
	*		5180	97.64	-	-	86.91	34.74	11.21	35.22	300	176	A	V
														V
														V
802.11a CH 44 5220MHz		5126.62	50.6	-23.4	74	40.02	34.62	11.18	35.22	100	274	P	H	
		5149.24	42.35	-11.65	54	31.7	34.66	11.21	35.22	100	274	A	H	
	*	5220	109.72	-	-	98.87	34.82	11.25	35.22	100	274	P	H	
	*	5220	102.64	-	-	91.79	34.82	11.25	35.22	100	274	A	H	
			5372.64	49.99	-24.01	74	38.28	35.18	11.76	35.23	100	274	P	H
			5433.12	44.34	-9.66	54	32.35	35.34	11.89	35.24	100	274	A	H
			5002.08	50.31	-23.69	74	40.15	34.3	11.07	35.21	300	177	P	V
			5109.2	41.74	-12.26	54	31.2	34.58	11.18	35.22	300	177	A	V
	*		5220	105.42	-	-	94.57	34.82	11.25	35.22	300	177	P	V
	*		5220	98.16	-	-	87.31	34.82	11.25	35.22	300	177	A	V
			5449.68	50.37	-23.63	74	38.34	35.38	11.89	35.24	300	177	P	V
			5431.2	42.48	-11.52	54	30.49	35.34	11.89	35.24	300	177	A	V



802.11a CH 48 5240MHz		5074.62	50.91	-23.09	74	40.48	34.5	11.14	35.21	100	273	P	H
		5120.38	42.01	-11.99	54	31.47	34.58	11.18	35.22	100	273	A	H
	*	5240	109.62	-	-	98.6	34.86	11.38	35.22	100	273	P	H
	*	5240	102.61	-	-	91.59	34.86	11.38	35.22	100	273	A	H
		5454.72	50.59	-23.41	74	38.56	35.38	11.89	35.24	100	273	P	H
		5454	44.16	-9.84	54	32.13	35.38	11.89	35.24	100	273	A	H
		5148.46	50.62	-23.38	74	39.97	34.66	11.21	35.22	300	171	P	V
		5121.68	41.6	-12.4	54	31.06	34.58	11.18	35.22	300	171	A	V
	*	5240	103.81	-	-	92.79	34.86	11.38	35.22	300	171	P	V
	*	5240	96.89	-	-	85.87	34.86	11.38	35.22	300	171	A	V
		5434.08	50.06	-23.94	74	38.07	35.34	11.89	35.24	300	171	P	V
		5452.32	42.62	-11.38	54	30.59	35.38	11.89	35.24	300	171	A	V
Remark	1. No other spurious found. 2. All results are PASS against Peak and Average limit line.												



Band 1 5150~5250MHz
WIFI 802.11a (Harmonic @ 3m)

WIFI	Note	Frequency	Level	Over	Limit	Read	Antenna	Cable	Preamp	Ant	Table	Peak	Pol.
Ant.				Limit	Line	Level	Factor	Loss	Factor	Pos	Pos	Avg.	
1+2		(MHz)	(dBμV/m)	(dB)	(dBμV/m)	(dBμV)	(dB/m)	(dB)	(dB)	(cm)	(deg)	(P/A)	(H/V)
802.11a CH 36 5180MHz		10360	42.28	-31.72	74	46.95	37.37	17.17	59.21	100	0	P	H
		15540	44.45	-29.55	74	41.66	40.36	19.61	57.18	100	0	P	H
													H
													H
		10360	43.02	-30.98	74	47.69	37.37	17.17	59.21	100	0	P	V
		15540	43.66	-30.34	74	40.87	40.36	19.61	57.18	100	0	P	V
													V
													V
802.11a CH 44 5220MHz		10440	41.99	-32.01	74	46.54	37.43	17.17	59.15	100	0	P	H
		15660	43.68	-30.32	74	40.53	40.58	19.68	57.11	100	0	P	H
													H
													H
		10440	43.78	-30.22	74	48.33	37.43	17.17	59.15	100	0	P	V
		15660	44.24	-29.76	74	41.09	40.58	19.68	57.11	100	0	P	V
													V
													V
802.11a CH 48 5240MHz		10480	43.14	-30.86	74	47.6	37.48	17.17	59.11	100	0	P	H
		15720	44.07	-29.93	74	40.71	40.7	19.73	57.07	100	0	P	H
													H
													H
		10480	43.41	-30.59	74	47.87	37.48	17.17	59.11	100	0	P	V
		15720	43.68	-30.32	74	40.32	40.7	19.73	57.07	100	0	P	V
													V
													V
Remark	1. No other spurious found. 2. All results are PASS against Peak and Average limit line.												



Band 1 5150~5250MHz
WIFI 802.11ac VHT20 (Band Edge @ 3m)

WIFI	Note	Frequency	Level	Over	Limit	Read	Antenna	Cable	Preamp	Ant	Table	Peak	Pol.	
Ant.				Limit	Line	Level	Factor	Loss	Factor	Pos	Pos	Avg.		
1+2		(MHz)	(dBμV/m)	(dB)	(dBμV/m)	(dBμV)	(dB/m)	(dB)	(dB)	(cm)	(deg)	(P/A)	(H/V)	
802.11ac VHT20 CH 36 5180MHz		5150	52.28	-21.72	74	41.63	34.66	11.21	35.22	100	258	P	H	
		5149.76	44.78	-9.22	54	34.13	34.66	11.21	35.22	100	258	A	H	
	*	5180	108.33	-	-	97.6	34.74	11.21	35.22	100	258	P	H	
	*	5180	101.5	-	-	90.77	34.74	11.21	35.22	100	258	A	H	
													H	
														H
			5138.06	51.95	-22.05	74	41.37	34.62	11.18	35.22	300	165	P	V
			5149.24	42.85	-11.15	54	32.2	34.66	11.21	35.22	300	165	A	V
	*		5180	105.94	-	-	95.21	34.74	11.21	35.22	300	165	P	V
	*		5180	98.7	-	-	87.97	34.74	11.21	35.22	300	165	A	V
													V	
													V	
802.11ac VHT20 CH 44 5220MHz		5105.3	50.97	-23.03	74	40.47	34.54	11.18	35.22	100	259	P	H	
		5149.24	42.09	-11.91	54	31.44	34.66	11.21	35.22	100	259	A	H	
	*	5220	108.77	-	-	97.92	34.82	11.25	35.22	100	259	P	H	
	*	5220	101.59	-	-	90.74	34.82	11.25	35.22	100	259	A	H	
			5399.04	50.11	-23.89	74	38.19	35.26	11.89	35.23	100	259	P	H
			5429.76	43.02	-10.98	54	31.03	35.34	11.89	35.24	100	259	A	H
			5072.02	50.56	-23.44	74	40.13	34.5	11.14	35.21	300	165	P	V
			5112.32	41.75	-12.25	54	31.21	34.58	11.18	35.22	300	165	A	V
	*		5220	105.79	-	-	94.94	34.82	11.25	35.22	300	165	P	V
	*		5220	99.11	-	-	88.26	34.82	11.25	35.22	300	165	A	V
		5357.52	50.43	-23.57	74	38.76	35.14	11.76	35.23	300	165	P	V	
		5429.28	43.3	-10.7	54	31.31	35.34	11.89	35.24	300	165	A	V	



802.11ac VHT20 CH 48 5240MHz		5073.32	50.72	-23.28	74	40.29	34.5	11.14	35.21	100	225	P	H
		5128.96	41.77	-12.23	54	31.19	34.62	11.18	35.22	100	225	A	H
	*	5240	109.64	-	-	98.62	34.86	11.38	35.22	100	225	P	H
	*	5240	102.35	-	-	91.33	34.86	11.38	35.22	100	225	A	H
		5386.08	51.3	-22.7	74	39.42	35.22	11.89	35.23	100	225	P	H
		5451.6	43.75	-10.25	54	31.72	35.38	11.89	35.24	100	225	A	H
		5013.52	50.43	-23.57	74	40.23	34.34	11.07	35.21	300	162	P	V
		5117.78	41.45	-12.55	54	30.91	34.58	11.18	35.22	300	162	A	V
	*	5240	104.77	-	-	93.75	34.86	11.38	35.22	300	162	P	V
	*	5240	99.13	-	-	88.11	34.86	11.38	35.22	300	162	A	V
		5369.28	49.93	-24.07	74	38.22	35.18	11.76	35.23	300	162	P	V
		5450.4	42.67	-11.33	54	30.64	35.38	11.89	35.24	300	162	A	V
Remark	1. No other spurious found. 2. All results are PASS against Peak and Average limit line.												



Band 1 5150~5250MHz
WIFI 802.11ac VHT20 (Harmonic @ 3m)

WIFI	Note	Frequency	Level	Over	Limit	Read	Antenna	Cable	Preamp	Ant	Table	Peak	Pol.
Ant.				Limit	Line	Level	Factor	Loss	Factor	Pos	Pos	Avg.	
1+2		(MHz)	(dBμV/m)	(dB)	(dBμV/m)	(dBμV)	(dB/m)	(dB)	(dB)	(cm)	(deg)	(P/A)	(H/V)
802.11ac VHT20 CH 36 5180MHz		10360	42.68	-31.32	74	47.35	37.37	17.17	59.21	100	0	P	H
		15540	45.57	-28.43	74	42.78	40.36	19.61	57.18	100	0	P	H
													H
													H
		10360	43.63	-30.37	74	48.3	37.37	17.17	59.21	100	0	P	V
		15540	45.1	-28.9	74	42.31	40.36	19.61	57.18	100	0	P	V
													V
802.11ac VHT20 CH 44 5220MHz		10440	43.33	-30.67	74	47.88	37.43	17.17	59.15	100	0	P	H
		15660	45.28	-28.72	74	42.13	40.58	19.68	57.11	100	0	P	H
													H
													H
		10440	43.05	-30.95	74	47.6	37.43	17.17	59.15	100	0	P	V
		15660	44.13	-29.87	74	40.98	40.58	19.68	57.11	100	0	P	V
													V
802.11ac VHT20 CH 48 5240MHz		10480	42.64	-31.36	74	47.1	37.48	17.17	59.11	100	0	P	H
		15720	43.6	-30.4	74	40.24	40.7	19.73	57.07	100	0	P	H
													H
													H
		10480	42.79	-31.21	74	47.25	37.48	17.17	59.11	100	0	P	V
		15720	43.88	-30.12	74	40.52	40.7	19.73	57.07	100	0	P	V
													V
Remark	1. No other spurious found.												
	2. All results are PASS against Peak and Average limit line.												



Band 1 5150~5250MHz
WIFI 802.11ac VHT40 (Band Edge @ 3m)

WIFI	Note	Frequency	Level	Over	Limit	Read	Antenna	Cable	Preamp	Ant	Table	Peak	Pol.
Ant.				Limit	Line	Level	Factor	Loss	Factor	Pos	Pos	Avg.	
1+2		(MHz)	(dBμV/m)	(dB)	(dBμV/m)	(dBμV)	(dB/m)	(dB)	(dB)	(cm)	(deg)	(P/A)	(H/V)
802.11ac VHT40 CH 38 5190MHz		5148.72	61.12	-12.88	74	50.47	34.66	11.21	35.22	100	225	P	H
		5149.5	52.01	-1.99	54	41.36	34.66	11.21	35.22	100	225	A	H
	*	5190	104.72	-	-	93.95	34.74	11.25	35.22	100	225	P	H
	*	5190	97.04	-	-	86.27	34.74	11.25	35.22	100	225	A	H
		5454.24	50.76	-23.24	74	38.73	35.38	11.89	35.24	100	225	P	H
		5350.08	40.98	-13.02	54	29.31	35.14	11.76	35.23	100	225	A	H
		5146.12	57.8	-16.2	74	47.15	34.66	11.21	35.22	300	149	P	V
		5144.3	48.14	-5.86	54	37.49	34.66	11.21	35.22	300	149	A	V
	*	5190	99.68	-	-	88.91	34.74	11.25	35.22	300	149	P	V
	*	5190	92.46	-	-	81.69	34.74	11.25	35.22	300	149	A	V
		5396.4	49.43	-24.57	74	37.51	35.26	11.89	35.23	300	149	P	V
		5455.2	40.8	-13.2	54	28.77	35.38	11.89	35.24	300	149	A	V
802.11ac VHT40 CH 46 5230MHz		5063.18	51.37	-22.63	74	40.98	34.46	11.14	35.21	100	223	P	H
		5149.76	42.28	-11.72	54	31.63	34.66	11.21	35.22	100	223	A	H
	*	5230	105.94	-	-	94.92	34.86	11.38	35.22	100	223	P	H
	*	5230	98.47	-	-	87.45	34.86	11.38	35.22	100	223	A	H
		5438.16	51.64	-22.36	74	39.65	35.34	11.89	35.24	100	223	P	H
		5385.12	41.59	-12.41	54	29.71	35.22	11.89	35.23	100	223	A	H
		5030.94	51.1	-22.9	74	40.82	34.38	11.11	35.21	300	170	P	V
		5140.92	41.13	-12.87	54	30.48	34.66	11.21	35.22	300	170	A	V
	*	5230	102.2	-	-	91.18	34.86	11.38	35.22	300	170	P	V
	*	5230	94.1	-	-	83.08	34.86	11.38	35.22	300	170	A	V
	5408.16	51.28	-22.72	74	39.36	35.26	11.89	35.23	300	170	P	V	
	5457.36	41.07	-12.93	54	29.04	35.38	11.89	35.24	300	170	A	V	
Remark	1. No other spurious found. 2. All results are PASS against Peak and Average limit line.												



Band 1 5150~5250MHz
WIFI 802.11ac VHT40 (Harmonic @ 3m)

WIFI	Note	Frequency	Level	Over	Limit	Read	Antenna	Cable	Preamp	Ant	Table	Peak	Pol.
Ant.				Limit	Line	Level	Factor	Loss	Factor	Pos	Pos	Avg.	
1+2		(MHz)	(dBμV/m)	(dB)	(dBμV/m)	(dBμV)	(dB/m)	(dB)	(dB)	(cm)	(deg)	(P/A)	(H/V)
802.11ac VHT40 CH 38 5190MHz		10380	42.73	-31.27	74	47.37	37.38	17.17	59.19	100	0	P	H
		15570	43.22	-30.78	74	40.33	40.42	19.63	57.16	100	0	P	H
													H
													H
		10380	42.43	-31.57	74	47.07	37.38	17.17	59.19	100	0	P	V
		15570	44.53	-29.47	74	41.64	40.42	19.63	57.16	100	0	P	V
													V
802.11ac VHT40 CH 46 5230MHz		10460	42.16	-31.84	74	46.68	37.45	17.17	59.14	100	0	P	H
		15690	44.43	-29.57	74	41.18	40.64	19.7	57.09	100	0	P	H
													H
													H
		10460	42.6	-31.4	74	47.12	37.45	17.17	59.14	100	0	P	V
		15690	43.98	-30.02	74	40.73	40.64	19.7	57.09	100	0	P	V
													V
Remark	1. No other spurious found.												
	2. All results are PASS against Peak and Average limit line.												



Band 1 5150~5250MHz
WIFI 802.11ac VHT80 (Band Edge @ 3m)

WIFI	Note	Frequency	Level	Over	Limit	Read	Antenna	Cable	Preamp	Ant	Table	Peak	Pol.
Ant.				Limit	Line	Level	Factor	Loss	Factor	Pos	Pos	Avg.	
1+2		(MHz)	(dBμV/m)	(dB)	(dBμV/m)	(dBμV)	(dB/m)	(dB)	(dB)	(cm)	(deg)	(P/A)	(H/V)
802.11ac VHT80 CH 42 5210MHz		5143.26	58.99	-15.01	74	48.34	34.66	11.21	35.22	100	279	P	H
		5146.38	50.12	-3.88	54	39.47	34.66	11.21	35.22	100	279	A	H
	*	5210	100.67	-	-	89.82	34.82	11.25	35.22	100	279	P	H
	*	5210	94.82	-	-	83.97	34.82	11.25	35.22	100	279	A	H
		5423.04	49.73	-24.27	74	37.78	35.3	11.89	35.24	100	279	P	H
		5350.8	41.5	-12.5	54	29.83	35.14	11.76	35.23	100	279	A	H
		5122.98	55.47	-18.53	74	44.89	34.62	11.18	35.22	300	178	P	V
		5121.94	47	-7	54	36.46	34.58	11.18	35.22	300	178	A	V
	*	5210	97.07	-	-	86.22	34.82	11.25	35.22	300	178	P	V
	*	5210	93.19	-	-	82.34	34.82	11.25	35.22	300	178	A	V
		5446.08	50.99	-23.01	74	38.96	35.38	11.89	35.24	300	178	P	V
	5353.68	41.17	-12.83	54	29.5	35.14	11.76	35.23	300	178	A	V	
Remark	1. No other spurious found. 2. All results are PASS against Peak and Average limit line.												



Band 1 5150~5250MHz
WIFI 802.11ac VHT80 (Harmonic @ 3m)

WIFI	Note	Frequency	Level	Over	Limit	Read	Antenna	Cable	Preamp	Ant	Table	Peak	Pol.	
Ant.				Limit	Line	Level	Factor	Loss	Factor	Pos	Pos	Avg.		
1+2		(MHz)	(dBμV/m)	(dB)	(dBμV/m)	(dBμV)	(dB/m)	(dB)	(dB)	(cm)	(deg)	(P/A)	(H/V)	
802.11ac VHT80 CH 42 5210MHz		10420	42.66	-31.34	74	47.24	37.42	17.17	59.17	100	0	P	H	
		15630	44.53	-29.47	74	41.42	40.55	19.68	57.12	100	0	P	H	
													H	
													H	
			10420	42.21	-31.79	74	46.79	37.42	17.17	59.17	100	0	P	V
			15630	44.99	-29.01	74	41.88	40.55	19.68	57.12	100	0	P	V
														V
Remark	1. No other spurious found. 2. All results are PASS against Peak and Average limit line.													



Band 2 - 5250~5350MHz
WIFI 802.11a (Band Edge @ 3m)

WIFI Ant. 1+2	Note	Frequency (MHz)	Level (dBμV/m)	Over Limit (dB)	Limit Line (dBμV/m)	Read Level (dBμV)	Antenna Factor (dB/m)	Cable Loss (dB)	Preamp Factor (dB)	Ant Pos (cm)	Table Pos (deg)	Peak Avg. (P/A)	Pol. (H/V)
802.11a CH 52 5260MHz		5083.98	51.06	-22.94	74	40.64	34.5	11.14	35.22	100	276	P	H
		5142.48	41.8	-12.2	54	31.15	34.66	11.21	35.22	100	276	A	H
	*	5260	109.46	-	-	98.37	34.94	11.38	35.23	100	276	P	H
	*	5260	102.39	-	-	91.3	34.94	11.38	35.23	100	276	A	H
		5381.28	51.82	-22.18	74	39.94	35.22	11.89	35.23	100	276	P	H
		5406	42.36	-11.64	54	30.44	35.26	11.89	35.23	100	276	A	H
		5056.94	49.9	-24.1	74	39.54	34.46	11.11	35.21	300	177	P	V
		5101.4	41.51	-12.49	54	31.01	34.54	11.18	35.22	300	177	A	V
	*	5260	104.61	-	-	93.52	34.94	11.38	35.23	300	177	P	V
	*	5260	97.8	-	-	86.71	34.94	11.38	35.23	300	177	A	V
		5355.6	49.91	-24.09	74	38.24	35.14	11.76	35.23	300	177	P	V
		5453.76	41.63	-12.37	54	29.6	35.38	11.89	35.24	300	177	A	V
802.11a CH 60 5300MHz		5127.4	50.71	-23.29	74	40.13	34.62	11.18	35.22	100	275	P	H
		5146.64	41.85	-12.15	54	31.2	34.66	11.21	35.22	100	275	A	H
	*	5300	109.24	-	-	97.94	35.02	11.51	35.23	100	275	P	H
	*	5300	102.25	-	-	90.95	35.02	11.51	35.23	100	275	A	H
		5350.08	52.85	-21.15	74	41.18	35.14	11.76	35.23	100	275	P	H
		5352.48	44.09	-9.91	54	32.42	35.14	11.76	35.23	100	275	A	H
		5088.66	51	-23	74	40.54	34.54	11.14	35.22	300	172	P	V
		5113.36	41.62	-12.38	54	31.08	34.58	11.18	35.22	300	172	A	V
	*	5300	104.81	-	-	93.51	35.02	11.51	35.23	300	172	P	V
	*	5300	97.65	-	-	86.35	35.02	11.51	35.23	300	172	A	V
		5352	51.73	-22.27	74	40.06	35.14	11.76	35.23	300	172	P	V
		5352.96	42.14	-11.86	54	30.47	35.14	11.76	35.23	300	172	A	V



802.11a CH 64 5320MHz	*	5320	109.47	-	-	98.01	35.06	11.63	35.23	102	275	P	H
	*	5320	102.47	-	-	91.01	35.06	11.63	35.23	102	275	A	H
		5354.24	53.71	-20.29	74	42.04	35.14	11.76	35.23	102	275	P	H
		5350.4	45.36	-8.64	54	33.69	35.14	11.76	35.23	102	275	A	H
													H
													H
	*	5320	105.18	-	-	93.72	35.06	11.63	35.23	300	177	P	V
	*	5320	97.92	-	-	86.46	35.06	11.63	35.23	300	177	A	V
		5352.64	50.57	-23.43	74	38.9	35.14	11.76	35.23	300	177	P	V
		5350.08	43.2	-10.8	54	31.53	35.14	11.76	35.23	300	177	A	V
													V
													V
Remark	1. No other spurious found. 2. All results are PASS against Peak and Average limit line.												



Band 2 5250~5350MHz
WIFI 802.11a (Harmonic @ 3m)

WIFI	Note	Frequency	Level	Over	Limit	Read	Antenna	Cable	Preamp	Ant	Table	Peak	Pol.
Ant.				Limit	Line	Level	Factor	Loss	Factor	Pos	Pos	Avg.	
1+2		(MHz)	(dBμV/m)	(dB)	(dBμV/m)	(dBμV)	(dB/m)	(dB)	(dB)	(cm)	(deg)	(P/A)	(H/V)
802.11a CH 52 5260MHz		10520	42.74	-31.26	74	47.14	37.51	17.17	59.08	100	0	P	H
		15780	42.74	-31.26	74	39.22	40.8	19.75	57.03	100	0	P	H
													H
													H
		10520	42.86	-31.14	74	47.26	37.51	17.17	59.08	100	0	P	V
		15780	43.7	-30.3	74	40.18	40.8	19.75	57.03	100	0	P	V
													V
													V
802.11a CH 60 5300MHz		10600	42.12	-31.88	74	46.33	37.58	17.17	58.96	100	0	P	H
		15900	43.34	-30.66	74	39.47	41.01	19.82	56.96	100	0	P	H
													H
													H
		10600	41.98	-32.02	74	46.19	37.58	17.17	58.96	100	0	P	V
		15900	43.92	-30.08	74	40.05	41.01	19.82	56.96	100	0	P	V
													V
													V
802.11a CH 64 5320MHz		10640	41.87	-32.13	74	46	37.61	17.17	58.91	100	0	P	H
		15960	43.43	-30.57	74	39.34	41.14	19.87	56.92	100	0	P	H
													H
													H
		10640	42.98	-31.02	74	47.11	37.61	17.17	58.91	100	0	P	V
		15960	43.91	-30.09	74	39.82	41.14	19.87	56.92	100	0	P	V
													V
													V
Remark	1. No other spurious found. 2. All results are PASS against Peak and Average limit line.												



Band 2 5250~5350MHz
WIFI 802.11ac VHT20 (Band Edge @ 3m)

WIFI	Note	Frequency	Level	Over	Limit	Read	Antenna	Cable	Preamp	Ant	Table	Peak	Pol.
Ant.				Limit	Line	Level	Factor	Loss	Factor	Pos	Pos	Avg.	
1+2		(MHz)	(dBμV/m)	(dB)	(dBμV/m)	(dBμV)	(dB/m)	(dB)	(dB)	(cm)	(deg)	(P/A)	(H/V)
802.11ac VHT20 CH 52 5260MHz		5046.02	49.75	-24.25	74	39.43	34.42	11.11	35.21	100	225	P	H
		5115.18	41.6	-12.4	54	31.06	34.58	11.18	35.22	100	225	A	H
	*	5260	110.09	-	-	99	34.94	11.38	35.23	100	225	P	H
	*	5260	102.37	-	-	91.28	34.94	11.38	35.23	100	225	A	H
		5383.68	50.67	-23.33	74	38.79	35.22	11.89	35.23	100	225	P	H
		5403.12	41.93	-12.07	54	30.01	35.26	11.89	35.23	100	225	A	H
		5082.68	50.98	-23.02	74	40.55	34.5	11.14	35.21	300	185	P	V
		5122.72	41.29	-12.71	54	30.71	34.62	11.18	35.22	300	185	A	V
	*	5260	105.75	-	-	94.66	34.94	11.38	35.23	300	185	P	V
	*	5260	99.14	-	-	88.05	34.94	11.38	35.23	300	185	A	V
		5432.4	49.21	-24.79	74	37.22	35.34	11.89	35.24	300	185	P	V
		5458.56	41.42	-12.58	54	29.39	35.38	11.89	35.24	300	185	A	V
802.11ac VHT20 CH 60 5300MHz		5118.82	51.29	-22.71	74	40.75	34.58	11.18	35.22	100	274	P	H
		5093.86	41.44	-12.56	54	30.98	34.54	11.14	35.22	100	274	A	H
	*	5300	108.85	-	-	97.55	35.02	11.51	35.23	100	274	P	H
	*	5300	101.26	-	-	89.96	35.02	11.51	35.23	100	274	A	H
		5421.36	52.13	-21.87	74	40.18	35.3	11.89	35.24	100	274	P	H
		5350.8	42.85	-11.15	54	31.18	35.14	11.76	35.23	100	274	A	H
		5046.28	50.06	-23.94	74	39.74	34.42	11.11	35.21	300	186	P	V
		5083.2	41.41	-12.59	54	30.98	34.5	11.14	35.21	300	186	A	V
	*	5300	105.22	-	-	93.92	35.02	11.51	35.23	300	186	P	V
	*	5300	98.19	-	-	86.89	35.02	11.51	35.23	300	186	A	V
	5350.08	51.16	-22.84	74	39.49	35.14	11.76	35.23	300	186	P	V	
	5351.04	42.4	-11.6	54	30.73	35.14	11.76	35.23	300	186	A	V	



802.11ac VHT20 CH 64 5320MHz	*	5320	109.05	-	-	97.59	35.06	11.63	35.23	100	224	P	H
	*	5320	101.1	-	-	89.64	35.06	11.63	35.23	100	224	A	H
		5395.52	51.34	-22.66	74	39.42	35.26	11.89	35.23	100	224	P	H
		5351.68	44.75	-9.25	54	33.08	35.14	11.76	35.23	100	224	A	H
													H
													H
	*	5320	105.8	-	-	94.34	35.06	11.63	35.23	300	188	P	V
	*	5320	98.8	-	-	87.34	35.06	11.63	35.23	300	188	A	V
		5351.36	51.01	-22.99	74	39.34	35.14	11.76	35.23	300	188	P	V
		5350.56	42.67	-11.33	54	31	35.14	11.76	35.23	300	188	A	V
												V	
												V	
Remark	1. No other spurious found. 2. All results are PASS against Peak and Average limit line.												



Band 2 5250~5350MHz
WIFI 802.11ac VHT20 (Harmonic @ 3m)

WIFI	Note	Frequency	Level	Over	Limit	Read	Antenna	Cable	Preamp	Ant	Table	Peak	Pol.
Ant.				Limit	Line	Level	Factor	Loss	Factor	Pos	Pos	Avg.	
1+2		(MHz)	(dBμV/m)	(dB)	(dBμV/m)	(dBμV)	(dB/m)	(dB)	(dB)	(cm)	(deg)	(P/A)	(H/V)
802.11ac VHT20 CH 52 5260MHz		10520	42.42	-31.58	74	46.82	37.51	17.17	59.08	100	0	P	H
		15780	43.29	-30.71	74	39.77	40.8	19.75	57.03	100	0	P	H
													H
													H
		10520	43.38	-30.62	74	47.78	37.51	17.17	59.08	100	0	P	V
		15780	43.34	-30.66	74	39.82	40.8	19.75	57.03	100	0	P	V
													V
802.11ac VHT20 CH 60 5300MHz		10600	41.69	-32.31	74	45.9	37.58	17.17	58.96	100	0	P	H
		15900	44.25	-29.75	74	40.38	41.01	19.82	56.96	100	0	P	H
													H
													H
		10600	41.41	-32.59	74	45.62	37.58	17.17	58.96	100	0	P	V
		15900	42.96	-31.04	74	39.09	41.01	19.82	56.96	100	0	P	V
													V
802.11ac VHT20 CH 64 5320MHz		10640	42.16	-31.84	74	46.29	37.61	17.17	58.91	100	0	P	H
		15960	43.5	-30.5	74	39.41	41.14	19.87	56.92	100	0	P	H
													H
													H
		10640	42.31	-31.69	74	46.44	37.61	17.17	58.91	100	0	P	V
		15960	43.54	-30.46	74	39.45	41.14	19.87	56.92	100	0	P	V
													V
Remark	1. No other spurious found.												
	2. All results are PASS against Peak and Average limit line.												



Band 2 5250~5350MHz
WIFI 802.11ac VHT40 (Band Edge @ 3m)

WIFI	Note	Frequency	Level	Over	Limit	Read	Antenna	Cable	Preamp	Ant	Table	Peak	Pol.
Ant.				Limit	Line	Level	Factor	Loss	Factor	Pos	Pos	Avg.	
1+2		(MHz)	(dBμV/m)	(dB)	(dBμV/m)	(dBμV)	(dB/m)	(dB)	(dB)	(cm)	(deg)	(P/A)	(H/V)
802.11ac VHT40 CH 54 5270MHz		5087.36	50.64	-23.36	74	40.22	34.5	11.14	35.22	100	275	P	H
		5135.72	40.98	-13.02	54	30.4	34.62	11.18	35.22	100	275	A	H
	*	5270	105.46	-	-	94.24	34.94	11.51	35.23	100	275	P	H
	*	5270	98.26	-	-	87.04	34.94	11.51	35.23	100	275	A	H
		5351.76	51.12	-22.88	74	39.45	35.14	11.76	35.23	100	275	P	H
		5350.56	42.31	-11.69	54	30.64	35.14	11.76	35.23	100	275	A	H
		5085.02	50.54	-23.46	74	40.12	34.5	11.14	35.22	300	146	P	V
		5122.72	40.91	-13.09	54	30.33	34.62	11.18	35.22	300	146	A	V
	*	5270	99.98	-	-	88.76	34.94	11.51	35.23	300	146	P	V
	*	5270	92.87	-	-	81.65	34.94	11.51	35.23	300	146	A	V
		5458.56	50.56	-23.44	74	38.53	35.38	11.89	35.24	300	146	P	V
		5457.36	40.85	-13.15	54	28.82	35.38	11.89	35.24	300	146	A	V
802.11ac VHT40 CH 62 5310MHz		5115.44	51.01	-22.99	74	40.47	34.58	11.18	35.22	100	225	P	H
		5113.36	42.26	-11.74	54	31.72	34.58	11.18	35.22	100	225	A	H
	*	5310	105.94	-	-	94.48	35.06	11.63	35.23	100	225	P	H
	*	5310	98.27	-	-	86.81	35.06	11.63	35.23	100	225	A	H
		5354.4	58.87	-15.13	74	47.2	35.14	11.76	35.23	100	225	P	H
		5350.32	52.78	-1.22	54	41.11	35.14	11.76	35.23	100	225	A	H
		5086.32	50.07	-23.93	74	39.65	34.5	11.14	35.22	300	172	P	V
		5111.02	40.85	-13.15	54	30.31	34.58	11.18	35.22	300	172	A	V
	*	5310	103.63	-	-	92.17	35.06	11.63	35.23	300	172	P	V
	*	5310	94.79	-	-	83.33	35.06	11.63	35.23	300	172	A	V
	5355.6	58.61	-15.39	74	46.94	35.14	11.76	35.23	300	172	P	V	
	5353.68	49.35	-4.65	54	37.68	35.14	11.76	35.23	300	172	P	V	
Remark	1. No other spurious found. 2. All results are PASS against Peak and Average limit line.												



Band 2 5250~5350MHz
WIFI 802.11ac VHT40 (Harmonic @ 3m)

WIFI	Note	Frequency	Level	Over	Limit	Read	Antenna	Cable	Preamp	Ant	Table	Peak	Pol.
Ant.				Limit	Line	Level	Factor	Loss	Factor	Pos	Pos	Avg.	
1+2		(MHz)	(dBμV/m)	(dB)	(dBμV/m)	(dBμV)	(dB/m)	(dB)	(dB)	(cm)	(deg)	(P/A)	(H/V)
802.11ac VHT40 CH 54 5270MHz		10540	43.9	-30.1	74	48.25	37.53	17.17	59.05	100	0	P	H
		15810	43.32	-30.68	74	39.7	40.86	19.77	57.01	100	0	P	H
													H
													H
		10540	42.9	-31.1	74	47.25	37.53	17.17	59.05	100	0	P	V
		15810	44.07	-29.93	74	40.45	40.86	19.77	57.01	100	0	P	V
													V
802.11ac VHT40 CH 62 5310MHz		10620	41.88	-32.12	74	46.04	37.6	17.17	58.93	100	0	P	H
		15930	43.36	-30.64	74	39.38	41.08	19.84	56.94	100	0	P	H
													H
													H
		10620	42.03	-31.97	74	46.19	37.6	17.17	58.93	100	0	P	V
		15930	43.5	-30.5	74	39.52	41.08	19.84	56.94	100	0	P	V
													V
Remark	1. No other spurious found.												
	2. All results are PASS against Peak and Average limit line.												



Band 2 5250~5350MHz
WIFI 802.11ac VHT80 (Band Edge @ 3m)

WIFI	Note	Frequency	Level	Over	Limit	Read	Antenna	Cable	Preamp	Ant	Table	Peak	Pol.
Ant.				Limit	Line	Level	Factor	Loss	Factor	Pos	Pos	Avg.	
1+2		(MHz)	(dBμV/m)	(dB)	(dBμV/m)	(dBμV)	(dB/m)	(dB)	(dB)	(cm)	(deg)	(P/A)	(H/V)
802.11ac VHT80 CH 58 5290MHz		5128.44	50.51	-23.49	74	39.93	34.62	11.18	35.22	100	222	P	H
		5148.72	43.97	-10.03	54	33.32	34.66	11.21	35.22	100	222	A	H
	*	5290	105.46	-	-	94.2	34.98	11.51	35.23	100	222	P	H
	*	5290	97.57	-	-	86.31	34.98	11.51	35.23	100	222	A	H
		5364.48	56.84	-17.16	74	45.13	35.18	11.76	35.23	100	222	P	H
		5361.6	51.17	-2.83	54	39.46	35.18	11.76	35.23	100	222	A	H
		5141.7	51.76	-22.24	74	41.11	34.66	11.21	35.22	300	168	P	V
		5150.02	42.28	-11.72	54	31.63	34.66	11.21	35.22	300	168	A	V
	*	5290	101.65	-	-	90.39	34.98	11.51	35.23	300	168	P	V
	*	5290	92.34	-	-	81.08	34.98	11.51	35.23	300	168	A	V
		5384.4	57.94	-16.06	74	46.06	35.22	11.89	35.23	300	168	P	V
	5379.6	48.11	-5.89	54	36.36	35.22	11.76	35.23	300	168	A	V	
Remark	1. No other spurious found. 2. All results are PASS against Peak and Average limit line.												



Band 2 5250~5350MHz
WIFI 802.11ac VHT80 (Harmonic @ 3m)

WIFI	Note	Frequency	Level	Over	Limit	Read	Antenna	Cable	Preamp	Ant	Table	Peak	Pol.	
Ant.				Limit	Line	Level	Factor	Loss	Factor	Pos	Pos	Avg.		
1+2		(MHz)	(dBμV/m)	(dB)	(dBμV/m)	(dBμV)	(dB/m)	(dB)	(dB)	(cm)	(deg)	(P/A)	(H/V)	
802.11ac VHT80 CH 58 5290MHz		10580	42.48	-31.52	74	46.72	37.57	17.17	58.98	100	0	P	H	
		15870	43.51	-30.49	74	39.68	40.98	19.82	56.97	100	0	P	H	
													H	
													H	
			10580	41.97	-32.03	74	46.21	37.57	17.17	58.98	100	0	P	V
			15870	44.08	-29.92	74	40.25	40.98	19.82	56.97	100	0	P	V
														V
													V	
Remark	1. No other spurious found. 2. All results are PASS against Peak and Average limit line.													



Band 3 - 5470~5725MHz
WIFI 802.11a (Band Edge @ 3m)

WIFI Ant. 1+2	Note	Frequency (MHz)	Level (dBμV/m)	Over Limit (dB)	Limit Line (dBμV/m)	Read Level (dBμV)	Antenna Factor (dB/m)	Cable Loss (dB)	Preamp Factor (dB)	Ant Pos (cm)	Table Pos (deg)	Peak Avg. (P/A)	Pol. (H/V)	
802.11a CH 100 5500MHz		5466.32	51.84	-22.16	74	39.77	35.42	11.89	35.24	103	275	P	H	
		5469.84	46.12	-7.88	54	34.05	35.42	11.89	35.24	103	275	A	H	
	*	5500	109.26	-	-	97.11	35.5	11.89	35.24	103	275	P	H	
	*	5500	102.18	-	-	90.03	35.5	11.89	35.24	103	275	A	H	
													H	
													H	
			5463.28	50.59	-23.41	74	38.52	35.42	11.89	35.24	295	178	P	V
			5469.68	44.26	-9.74	54	32.19	35.42	11.89	35.24	295	178	A	V
	*		5500	106.02	-	-	93.87	35.5	11.89	35.24	295	178	P	V
	*		5500	98.87	-	-	86.72	35.5	11.89	35.24	295	178	A	V
														V
														V
802.11a CH 116 5580MHz		5384.56	50.93	-23.07	74	39.05	35.22	11.89	35.23	103	274	P	H	
		5469.52	42.26	-11.74	54	30.19	35.42	11.89	35.24	103	274	A	H	
	*	5580	108.97	-	-	96.83	35.51	11.89	35.26	103	274	P	H	
	*	5580	101.78	-	-	89.64	35.51	11.89	35.26	103	274	A	H	
			5747.85	50.8	-23.2	74	38.43	35.55	12.11	35.29	103	274	P	H
			5736.3	42.96	-11.04	54	30.64	35.55	12.06	35.29	103	274	A	H
			5393.2	51.38	-22.62	74	39.5	35.22	11.89	35.23	300	178	P	V
			5469.76	41.81	-12.19	54	29.74	35.42	11.89	35.24	300	178	A	V
	*		5580	104.07	-	-	91.93	35.51	11.89	35.26	300	178	P	V
	*		5580	97.17	-	-	85.03	35.51	11.89	35.26	300	178	A	V
			5735.6	50.72	-23.28	74	38.4	35.55	12.06	35.29	300	178	P	V
			5735.25	42.28	-11.72	54	29.96	35.55	12.06	35.29	300	178	A	V



802.11a CH 140 5700MHz	*	5700	107.62	-	-	95.36	35.54	12	35.28	100	271	P	H
	*	5700	100.24	-	-	87.98	35.54	12	35.28	100	271	A	H
		5725.64	54.33	-19.67	74	42.02	35.54	12.06	35.29	100	271	P	H
		5730.68	44.85	-9.15	54	32.54	35.54	12.06	35.29	100	271	A	H
													H
													H
	*	5700	103.97	-	-	91.71	35.54	12	35.28	306	174	P	V
	*	5700	96.71	-	-	84.45	35.54	12	35.28	306	174	A	V
		5756.44	51.67	-22.33	74	39.3	35.55	12.11	35.29	306	174	P	V
		5725.16	42.95	-11.05	54	30.64	35.54	12.06	35.29	306	174	A	V
													V
													V
Remark	1. No other spurious found. 2. All results are PASS against Peak and Average limit line.												



Band 3 - 5470~5725MHz
WIFI 802.11a (Harmonic @ 3m)

WIFI	Note	Frequency	Level	Over	Limit	Read	Antenna	Cable	Preamp	Ant	Table	Peak	Pol.
Ant.				Limit	Line	Level	Factor	Loss	Factor	Pos	Pos	Avg.	
1+2		(MHz)	(dBμV/m)	(dB)	(dBμV/m)	(dBμV)	(dB/m)	(dB)	(dB)	(cm)	(deg)	(P/A)	(H/V)
802.11a CH 100 5500MHz		11000	43.99	-30.01	74	47.32	37.9	17.17	58.4	100	0	P	H
		16500	45.37	-28.63	74	39.64	41.6	20.23	56.1	100	0	P	H
													H
													H
		11000	43.09	-30.91	74	46.42	37.9	17.17	58.4	100	0	P	V
		16500	45.03	-28.97	74	39.3	41.6	20.23	56.1	100	0	P	V
													V
													V
802.11a CH 116 5580MHz		11160	43.16	-30.84	74	45.96	38.07	17.16	58.03	100	0	P	H
		16740	44.61	-29.39	74	38.29	41.89	20.39	55.96	100	0	P	H
													H
													H
		11160	42.76	-31.24	74	45.56	38.07	17.16	58.03	100	0	P	V
		16740	44.93	-29.07	74	38.61	41.89	20.39	55.96	100	0	P	V
													V
													V
802.11a CH 140 5700MHz		11400	42.48	-31.52	74	44.54	38.3	17.16	57.52	100	0	P	H
		17100	46.24	-27.76	74	39.29	42.14	20.65	55.84	100	0	P	H
													H
													H
		11400	42.88	-31.12	74	44.94	38.3	17.16	57.52	100	0	P	V
		17100	46.24	-27.76	74	39.29	42.14	20.65	55.84	100	0	P	V
													V
													V
Remark	1. No other spurious found. 2. All results are PASS against Peak and Average limit line.												



Band 3 - 5470~5725MHz
WIFI 802.11ac VHT20 (Band Edge @ 3m)

WIFI	Note	Frequency	Level	Over	Limit	Read	Antenna	Cable	Preamp	Ant	Table	Peak	Pol.	
Ant.				Limit	Line	Level	Factor	Loss	Factor	Pos	Pos	Avg.		
1+2		(MHz)	(dBμV/m)	(dB)	(dBμV/m)	(dBμV)	(dB/m)	(dB)	(dB)	(cm)	(deg)	(P/A)	(H/V)	
802.11ac VHT20 CH 100 5500MHz		5465.52	52.74	-21.26	74	40.67	35.42	11.89	35.24	100	226	P	H	
		5469.84	44.23	-9.77	54	32.16	35.42	11.89	35.24	100	226	A	H	
	*	5500	107.55	-	-	95.4	35.5	11.89	35.24	100	226	P	H	
	*	5500	100.48	-	-	88.33	35.5	11.89	35.24	100	226	A	H	
													H	
													H	
			5469.52	52.75	-21.25	74	40.68	35.42	11.89	35.24	300	159	P	V
			5469.2	42.93	-11.07	54	30.86	35.42	11.89	35.24	300	159	A	V
	*		5500	105.39	-	-	93.24	35.5	11.89	35.24	300	159	P	V
	*		5500	98.28	-	-	86.13	35.5	11.89	35.24	300	159	A	V
													V	
													V	
802.11ac VHT20 CH 116 5580MHz		5470	50.19	-23.81	74	38.12	35.42	11.89	35.24	100	279	P	H	
		5468.32	41.59	-12.41	54	29.52	35.42	11.89	35.24	100	279	A	H	
	*	5580	106.05	-	-	93.91	35.51	11.89	35.26	100	279	P	H	
	*	5580	98.79	-	-	86.65	35.51	11.89	35.26	100	279	A	H	
			5734.725	50.67	-23.33	74	38.35	35.55	12.06	35.29	100	279	P	H
			5726.675	42.12	-11.88	54	29.81	35.54	12.06	35.29	100	279	A	H
			5446.48	49.66	-24.34	74	37.63	35.38	11.89	35.24	300	172	P	V
			5469.52	41.66	-12.34	54	29.59	35.42	11.89	35.24	300	172	A	V
	*		5580	104.22	-	-	92.08	35.51	11.89	35.26	300	172	P	V
	*		5580	96.77	-	-	84.63	35.51	11.89	35.26	300	172	A	V
		5764.825	50.83	-23.17	74	38.46	35.55	12.11	35.29	300	172	P	V	
		5734.375	42	-12	54	29.69	35.54	12.06	35.29	300	172	A	V	



802.11ac VHT20 CH 140 5700MHz	*	5700	106.4	-	-	94.14	35.54	12	35.28	100	279	P	H
	*	5700	99.49	-	-	87.23	35.54	12	35.28	100	279	A	H
		5734.36	51.35	-22.65	74	39.04	35.54	12.06	35.29	100	279	P	H
		5730.28	44.26	-9.74	54	31.95	35.54	12.06	35.29	100	279	A	H
													H
													H
	*	5700	103.33	-	-	91.07	35.54	12	35.28	300	158	P	V
	*	5700	96.56	-	-	84.3	35.54	12	35.28	300	158	A	V
		5755	51.48	-22.52	74	39.11	35.55	12.11	35.29	300	158	P	V
		5730.44	43.4	-10.6	54	31.09	35.54	12.06	35.29	300	158	A	V
												V	
												V	
Remark	1. No other spurious found. 2. All results are PASS against Peak and Average limit line.												



Band 3 - 5470~5725MHz
WIFI 802.11ac VHT20 (Harmonic @ 3m)

WIFI	Note	Frequency	Level	Over	Limit	Read	Antenna	Cable	Preamp	Ant	Table	Peak	Pol.
Ant.				Limit	Line	Level	Factor	Loss	Factor	Pos	Pos	Avg.	
1+2		(MHz)	(dBμV/m)	(dB)	(dBμV/m)	(dBμV)	(dB/m)	(dB)	(dB)	(cm)	(deg)	(P/A)	(H/V)
802.11ac VHT20 CH 100 5500MHz		11000	43.55	-30.45	74	46.88	37.9	17.17	58.4	100	0	P	H
		16500	46.61	-27.39	74	40.88	41.6	20.23	56.1	100	0	P	H
													H
													H
		11000	43.94	-30.06	74	47.27	37.9	17.17	58.4	100	0	P	V
		16500	46.23	-27.77	74	40.5	41.6	20.23	56.1	100	0	P	V
													V
802.11ac VHT20 CH 116 5580MHz		11160	43.64	-30.36	74	46.44	38.07	17.16	58.03	100	0	P	H
		16740	44.68	-29.32	74	38.36	41.89	20.39	55.96	100	0	P	H
													H
													H
		11160	43	-31	74	45.8	38.07	17.16	58.03	100	0	P	V
		16740	45.99	-28.01	74	39.67	41.89	20.39	55.96	100	0	P	V
													V
802.11ac VHT20 CH 140 5700MHz		11400	44.11	-29.89	74	46.17	38.3	17.16	57.52	100	0	P	H
		17100	46.71	-27.29	74	39.76	42.14	20.65	55.84	100	0	P	H
													H
													H
		11400	42.8	-31.2	74	44.86	38.3	17.16	57.52	100	0	P	V
		17100	47.1	-26.9	74	40.15	42.14	20.65	55.84	100	0	P	V
													V
Remark	1. No other spurious found.												
	2. All results are PASS against Peak and Average limit line.												



Band 3 - 5470~5725MHz
WIFI 802.11ac VHT40 (Band Edge @ 3m)

WIFI	Note	Frequency	Level	Over	Limit	Read	Antenna	Cable	Preamp	Ant	Table	Peak	Pol.
Ant.				Limit	Line	Level	Factor	Loss	Factor	Pos	Pos	Avg.	
1+2		(MHz)	(dBμV/m)	(dB)	(dBμV/m)	(dBμV)	(dB/m)	(dB)	(dB)	(cm)	(deg)	(P/A)	(H/V)
802.11ac VHT40 CH 102 5510MHz		5468.08	59.01	-14.99	74	46.94	35.42	11.89	35.24	100	280	P	H
		5470	52.55	-1.45	54	40.48	35.42	11.89	35.24	100	280	A	H
	*	5510	104.15	-	-	92	35.5	11.89	35.24	100	280	P	H
	*	5510	96.57	-	-	84.42	35.5	11.89	35.24	100	280	A	H
		5741.2	50.53	-23.47	74	38.16	35.55	12.11	35.29	100	280	P	H
		5738.05	41.5	-12.5	54	29.18	35.55	12.06	35.29	100	280	A	H
		5470	60.46	-13.54	74	48.39	35.42	11.89	35.24	300	164	P	V
		5466.64	52.63	-1.37	54	40.56	35.42	11.89	35.24	300	164	A	V
	*	5510	100.89	-	-	88.74	35.5	11.89	35.24	300	164	P	V
	*	5510	94.31	-	-	82.16	35.5	11.89	35.24	300	164	A	V
		5735.425	50.51	-23.49	74	38.19	35.55	12.06	35.29	300	164	P	V
		5744.175	41.47	-12.53	54	29.1	35.55	12.11	35.29	300	164	A	V
802.11ac VHT40 CH 110 5550MHz		5465.68	50.96	-23.04	74	38.89	35.42	11.89	35.24	100	280	P	H
		5469.76	43.79	-10.21	54	31.72	35.42	11.89	35.24	100	280	A	H
	*	5550	103.86	-	-	91.71	35.51	11.89	35.25	100	280	P	H
	*	5550	97.69	-	-	85.54	35.51	11.89	35.25	100	280	A	H
		5727.55	50.33	-23.67	74	38.02	35.54	12.06	35.29	100	280	P	H
		5727.725	41.84	-12.16	54	29.53	35.54	12.06	35.29	100	280	A	H
		5467.36	50.57	-23.43	74	38.5	35.42	11.89	35.24	300	174	P	V
		5469.76	43.24	-10.76	54	31.17	35.42	11.89	35.24	300	174	A	V
	*	5550	101.34	-	-	89.19	35.51	11.89	35.25	300	174	P	V
	*	5550	94.51	-	-	82.36	35.51	11.89	35.25	300	174	A	V
	5757.125	50.92	-23.08	74	38.55	35.55	12.11	35.29	300	174	P	V	
	5763.25	41.69	-12.31	54	29.32	35.55	12.11	35.29	300	174	A	V	



802.11ac VHT40 CH 134 5670MHz		5371.6	49.77	-24.23	74	38.06	35.18	11.76	35.23	100	279	P	H
		5467.6	40.98	-13.02	54	28.91	35.42	11.89	35.24	100	279	A	H
	*	5670	103.4	-	-	91.14	35.53	12	35.27	100	279	P	H
	*	5670	96.95	-	-	84.69	35.53	12	35.27	100	279	A	H
		5732.275	52.13	-21.87	74	39.82	35.54	12.06	35.29	100	279	P	H
		5728.25	44.35	-9.65	54	32.04	35.54	12.06	35.29	100	279	A	H
		5428.96	50.64	-23.36	74	38.65	35.34	11.89	35.24	295	167	P	V
		5465.44	40.93	-13.07	54	28.86	35.42	11.89	35.24	295	167	A	V
	*	5670	101.64	-	-	89.38	35.53	12	35.27	295	167	P	V
	*	5670	94.25	-	-	81.99	35.53	12	35.27	295	167	A	V
		5745.4	51.92	-22.08	74	39.55	35.55	12.11	35.29	295	167	P	V
	5729.65	42.23	-11.77	54	29.92	35.54	12.06	35.29	295	167	A	V	
Remark	1. No other spurious found. 2. All results are PASS against Peak and Average limit line.												



Band 3 - 5470~5725MHz
WIFI 802.11ac VHT40 (Harmonic @ 3m)

WIFI	Note	Frequency	Level	Over	Limit	Read	Antenna	Cable	Preamp	Ant	Table	Peak	Pol.
Ant.				Limit	Line	Level	Factor	Loss	Factor	Pos	Pos	Avg.	
1+2		(MHz)	(dBμV/m)	(dB)	(dBμV/m)	(dBμV)	(dB/m)	(dB)	(dB)	(cm)	(deg)	(P/A)	(H/V)
802.11ac VHT40 CH 102 5510MHz		11020	43.21	-30.79	74	46.48	37.92	17.17	58.36	100	0	P	H
		16530	45.13	-28.87	74	39.32	41.64	20.25	56.08	100	0	P	H
													H
													H
		11020	43.46	-30.54	74	46.73	37.92	17.17	58.36	100	0	P	V
		16530	44.53	-29.47	74	38.72	41.64	20.25	56.08	100	0	P	V
													V
802.11ac VHT40 CH 110 5550MHz		11100	43.43	-30.57	74	46.45	38	17.16	58.18	100	0	P	H
		16650	45.92	-28.08	74	39.8	41.79	20.34	56.01	100	0	P	H
													H
													H
		11100	43.58	-30.42	74	46.6	38	17.16	58.18	100	0	P	V
		16650	46.12	-27.88	74	40	41.79	20.34	56.01	100	0	P	V
													V
802.11ac VHT40 CH 134 5670MHz		11340	42.56	-31.44	74	44.84	38.23	17.16	57.67	100	0	P	H
		17010	46.9	-27.1	74	39.93	42.19	20.59	55.81	100	0	P	H
													H
													H
		11340	43.12	-30.88	74	45.4	38.23	17.16	57.67	100	0	P	V
		17010	45.9	-28.1	74	38.93	42.19	20.59	55.81	100	0	P	V
													V
Remark	1. No other spurious found.												
	2. All results are PASS against Peak and Average limit line.												



Band 3 5470~5725MHz
WIFI 802.11ac VHT80 (Band Edge @ 3m)

WIFI	Note	Frequency	Level	Over	Limit	Read	Antenna	Cable	Preamp	Ant	Table	Peak	Pol.
Ant.				Limit	Line	Level	Factor	Loss	Factor	Pos	Pos	Avg.	
1+2		(MHz)	(dBμV/m)	(dB)	(dBμV/m)	(dBμV)	(dB/m)	(dB)	(dB)	(cm)	(deg)	(P/A)	(H/V)
802.11ac VHT80 CH 106 5530MHz		5464.48	59.15	-14.85	74	47.08	35.42	11.89	35.24	100	279	P	H
		5467.84	51.22	-2.78	54	39.15	35.42	11.89	35.24	100	279	A	H
	*	5530	101.16	-	-	89.02	35.5	11.89	35.25	100	279	P	H
	*	5530	95.27	-	-	83.13	35.5	11.89	35.25	100	279	A	H
		5734.55	52.74	-21.26	74	40.42	35.55	12.06	35.29	100	279	P	H
		5727.375	42.01	-11.99	54	29.7	35.54	12.06	35.29	100	279	A	H
		5468.08	56.56	-17.44	74	44.49	35.42	11.89	35.24	300	188	P	V
		5468.56	48.45	-5.55	54	36.38	35.42	11.89	35.24	300	188	A	V
	*	5530	100.96	-	-	88.82	35.5	11.89	35.25	300	188	P	V
	*	5530	92.3	-	-	80.16	35.5	11.89	35.25	300	188	A	V
		5762.025	51.61	-22.39	74	39.24	35.55	12.11	35.29	300	188	P	V
		5743.65	41.66	-12.34	54	29.29	35.55	12.11	35.29	300	188	A	V
802.11ac VHT80 CH 122 5610MHz		5468.56	50.35	-23.65	74	38.28	35.42	11.89	35.24	100	279	P	H
		5469.52	42.6	-11.4	54	30.53	35.42	11.89	35.24	100	279	A	H
	*	5610	105.1	-	-	92.95	35.52	11.89	35.26	100	279	P	H
	*	5610	95.36	-	-	83.21	35.52	11.89	35.26	100	279	A	H
		5725.625	51.14	-22.86	74	38.83	35.54	12.06	35.29	100	279	P	H
		5732.45	43.49	-10.51	54	31.18	35.54	12.06	35.29	100	279	A	H
		5469.04	51.33	-22.67	74	39.26	35.42	11.89	35.24	300	170	P	V
		5467.6	43.05	-10.95	54	30.98	35.42	11.89	35.24	300	170	A	V
	*	5610	101.9	-	-	89.75	35.52	11.89	35.26	300	170	P	V
	*	5610	92.49	-	-	80.34	35.52	11.89	35.26	300	170	A	V
	5761.675	51.84	-22.16	74	39.47	35.55	12.11	35.29	300	170	P	V	
	5724.925	42.63	-11.37	54	30.31	35.54	12.06	35.28	300	170	A	V	
Remark	1. No other spurious found. 2. All results are PASS against Peak and Average limit line.												



Band 3 5470~5725MHz
WIFI 802.11ac VHT80 (Harmonic @ 3m)

WIFI	Note	Frequency	Level	Over	Limit	Read	Antenna	Cable	Preamp	Ant	Table	Peak	Pol.
Ant.				Limit	Line	Level	Factor	Loss	Factor	Pos	Pos	Avg.	
1+2		(MHz)	(dBμV/m)	(dB)	(dBμV/m)	(dBμV)	(dB/m)	(dB)	(dB)	(cm)	(deg)	(P/A)	(H/V)
802.11ac VHT80 CH 106 5530MHz		11060	42.46	-31.54	74	45.58	37.97	17.16	58.25	100	0	P	H
		16590	44.93	-29.07	74	38.97	41.7	20.31	56.05	100	0	P	H
													H
													H
		11060	42.9	-31.1	74	46.02	37.97	17.16	58.25	100	0	P	V
		16590	44.67	-29.33	74	38.71	41.7	20.31	56.05	100	0	P	V
802.11ac VHT80 CH 122 5610MHz		11220	42.16	-31.84	74	44.8	38.12	17.16	57.92	100	0	P	H
		16830	46.64	-27.36	74	40.07	41.99	20.48	55.9	100	0	P	H
													H
													H
		11220	42.53	-31.47	74	45.17	38.12	17.16	57.92	100	0	P	V
		16830	46.38	-27.62	74	39.81	41.99	20.48	55.9	100	0	P	V
Remark	1. No other spurious found.												
	2. All results are PASS against Peak and Average limit line.												



Band 3 - Straddle Channel
WIFI 802.11ac VHT20 (Band Edge @ 3m)

WIFI	Note	Frequency	Level	Over	Limit	Read	Antenna	Cable	Preamp	Ant	Table	Peak	Pol.
Ant.				Limit	Line	Level	Factor	Loss	Factor	Pos	Pos	Avg.	
1+2		(MHz)	(dBμV/m)	(dB)	(dBμV/m)	(dBμV)	(dB/m)	(dB)	(dB)	(cm)	(deg)	(P/A)	(H/V)
802.11ac VHT20 CH 144 5720MHz	*	5720	108.4	-	-	96.08	35.54	12.06	35.28	100	296	P	H
	*	5720	99.93	-	-	87.61	35.54	12.06	35.28	100	296	A	H
													H
													H
													H
													H
	*	5720	106.16	-	-	93.84	35.54	12.06	35.28	274	172	P	V
	*	5720	99.2	-	-	86.88	35.54	12.06	35.28	274	172	A	V
													V
													V
												V	
												V	
Remark	1. No other spurious found. 2. All results are PASS against Peak and Average limit line.												



Band 3 - Straddle Channel
WIFI 802.11ac VHT20 (Harmonic @ 3m)

WIFI	Note	Frequency	Level	Over	Limit	Read	Antenna	Cable	Preamp	Ant	Table	Peak	Pol.	
Ant.				Limit	Line	Level	Factor	Loss	Factor	Pos	Pos	Avg.		
1+2		(MHz)	(dBμV/m)	(dB)	(dBμV/m)	(dBμV)	(dB/m)	(dB)	(dB)	(cm)	(deg)	(P/A)	(H/V)	
802.11ac VHT20 CH 144 5720MHz		11440	43.06	-30.94	74	45.02	38.33	17.16	57.45	100	0	P	H	
		17160	47.02	-26.98	74	40.09	42.1	20.7	55.87	100	0	P	H	
													H	
													H	
			11440	43.05	-30.95	74	45.01	38.33	17.16	57.45	100	0	P	V
			17160	46.88	-27.12	74	39.95	42.1	20.7	55.87	100	0	P	V
														V
													V	
Remark	1. No other spurious found. 2. All results are PASS against Peak and Average limit line.													



Band 3 - Straddle Channel
WIFI 802.11ac VHT40 (Band Edge @ 3m)

WIFI	Note	Frequency	Level	Over	Limit	Read	Antenna	Cable	Preamp	Ant	Table	Peak	Pol.
Ant.				Limit	Line	Level	Factor	Loss	Factor	Pos	Pos	Avg.	
1+2		(MHz)	(dBμV/m)	(dB)	(dBμV/m)	(dBμV)	(dB/m)	(dB)	(dB)	(cm)	(deg)	(P/A)	(H/V)
802.11ac VHT40 CH 142 5710MHz	*	5710	104.19	-	-	91.87	35.54	12.06	35.28	100	296	P	H
	*	5710	97.14	-	-	84.82	35.54	12.06	35.28	100	296	A	H
													H
													H
													H
													H
	*	5710	103.96	-	-	91.64	35.54	12.06	35.28	274	174	P	V
	*	5710	96.82	-	-	84.5	35.54	12.06	35.28	274	174	A	V
													V
													V
												V	
												V	
Remark	1. No other spurious found. 2. All results are PASS against Peak and Average limit line.												



Band 3 - Straddle Channel
WIFI 802.11ac VHT40 (Harmonic @ 3m)

WIFI	Note	Frequency	Level	Over	Limit	Read	Antenna	Cable	Preamp	Ant	Table	Peak	Pol.	
Ant.				Limit	Line	Level	Factor	Loss	Factor	Pos	Pos	Avg.		
1+2		(MHz)	(dBμV/m)	(dB)	(dBμV/m)	(dBμV)	(dB/m)	(dB)	(dB)	(cm)	(deg)	(P/A)	(H/V)	
802.11ac VHT40 CH 142 5710MHz		11420	42.69	-31.31	74	44.69	38.32	17.16	57.48	100	0	P	H	
		17130	46.81	-27.19	74	39.87	42.12	20.67	55.85	100	0	P	H	
													H	
													H	
			11420	43.12	-30.88	74	45.12	38.32	17.16	57.48	100	0	P	V
			17130	47.09	-26.91	74	40.15	42.12	20.67	55.85	100	0	P	V
														V
													V	
Remark	1. No other spurious found. 2. All results are PASS against Peak and Average limit line.													



Band 3 - Straddle Channel
WIFI 802.11ac VHT80 (Band Edge @ 3m)

WIFI	Note	Frequency	Level	Over	Limit	Read	Antenna	Cable	Preamp	Ant	Table	Peak	Pol.
Ant.				Limit	Line	Level	Factor	Loss	Factor	Pos	Pos	Avg.	
1+2		(MHz)	(dBμV/m)	(dB)	(dBμV/m)	(dBμV)	(dB/m)	(dB)	(dB)	(cm)	(deg)	(P/A)	(H/V)
802.11ac VHT80 CH 138 5690MHz	*	5690	101.16	-	-	88.9	35.54	12	35.28	100	296	P	H
	*	5690	95.09	-	-	82.83	35.54	12	35.28	100	296	A	H
													H
													H
													H
													H
	*	5690	99.96	-	-	87.7	35.54	12	35.28	274	172	P	V
	*	5690	93.23	-	-	80.97	35.54	12	35.28	274	172	A	V
													V
													V
												V	
												V	
Remark	1. No other spurious found. 2. All results are PASS against Peak and Average limit line.												



**Band 3 - Straddle Channel
WIFI 802.11ac VHT80 (Harmonic @ 3m)**

WIFI	Note	Frequency	Level	Over	Limit	Read	Antenna	Cable	Preamp	Ant	Table	Peak	Pol.	
Ant.				Limit	Line	Level	Factor	Loss	Factor	Pos	Pos	Avg.		
1+2		(MHz)	(dBμV/m)	(dB)	(dBμV/m)	(dBμV)	(dB/m)	(dB)	(dB)	(cm)	(deg)	(P/A)	(H/V)	
802.11ac VHT80 CH 138 5690MHz		11380	43.14	-30.86	74	45.26	38.28	17.16	57.56	100	0	P	H	
		17070	46.97	-27.03	74	39.99	42.16	20.65	55.83	100	0	P	H	
													H	
													H	
			11380	43.01	-30.99	74	45.13	38.28	17.16	57.56	100	0	P	V
			17070	46.32	-27.68	74	39.34	42.16	20.65	55.83	100	0	P	V
														V
Remark	1. No other spurious found. 2. All results are PASS against Peak and Average limit line.													



Emission below 1GHz
WIFI 802.11a (LF @ 3m)

WIFI Ant. 1+2	Note	Frequency (MHz)	Level (dBμV/m)	Over Limit (dB)	Limit Line (dBμV/m)	Read Level (dBμV)	Antenna Factor (dB/m)	Cable Loss (dB)	Preamp Factor (dB)	Ant Pos (cm)	Table Pos (deg)	Peak Avg. (P/A)	Pol. (H/V)	
802.11a LF		30	28.09	-11.91	40	32.37	26	1.07	31.35	-	-	P	H	
		101.01	32.14	-11.36	43.5	45.62	16.49	1.55	31.52	-	-	P	H	
		240.06	31.85	-14.15	46	43.09	18.09	2.07	31.4	-	-	P	H	
		360.2	28.26	-17.74	46	35.53	21.44	2.5	31.21	-	-	P	H	
		659.8	39.57	-6.43	46	40.76	26	3.57	30.76	-	-	P	H	
		780.2	39.6	-6.4	46	38.82	27.5	3.9	30.62	100	0	P	H	
														H
														H
														H
														H
														H
														H
														H
														H
														H
			35.13	32.46	-7.54	40	39.5	23.3	1.07	31.41	100	0	P	V
			99.66	30.36	-13.14	43.5	44.2	16.4	1.28	31.52	-	-	P	V
			240.06	29.54	-16.46	46	40.78	18.09	2.07	31.4	-	-	P	V
		379.8	23.99	-22.01	46	30.75	21.93	2.5	31.19	-	-	P	V	
		540.1	32.34	-13.66	46	35.52	24.52	3.24	30.94	-	-	P	V	
		780.2	34.36	-11.64	46	33.58	27.5	3.9	30.62	-	-	P	V	
													V	
													V	
													V	
													V	
													V	
													V	
Remark	1. No other spurious found. 2. All results are PASS against limit line.													



Emission below 1GHz

5GHz WIFI 802.11ac VHT20 (LF @ 3m)

WIFI Ant. 1+2	Note	Frequency (MHz)	Level (dBµV/m)	Over Limit (dB)	Limit Line (dBµV/m)	Read Level (dBµV)	Antenna Factor (dB/m)	Cable Loss (dB)	Preamp Factor (dB)	Ant Pos (cm)	Table Pos (deg)	Peak Avg. (P/A)	Pol. (H/V)	
5GHz 802.11ac VHT20 LF		88.86	31.9	-11.6	43.5	47.18	14.98	1.28	31.54	-	-	P	H	
		98.31	31.91	-11.59	43.5	46.01	16.14	1.28	31.52	-	-	P	H	
		240.06	32.31	-13.69	46	43.55	18.09	2.07	31.4	-	-	P	H	
		479.9	30.8	-15.2	46	35.05	23.76	3.04	31.05	-	-	P	H	
		659.8	39.71	-6.29	46	40.9	26	3.57	30.76	100	0	P	H	
		780.2	39.21	-6.79	46	38.43	27.5	3.9	30.62	-	-	P	H	
														H
														H
														H
														H
														H
														H
			34.59	29.73	-10.27	40	36.77	23.3	1.07	31.41	100	0	P	V
			101.01	31.51	-11.99	43.5	44.99	16.49	1.55	31.52	-	-	P	V
			240.06	29.92	-16.08	46	41.16	18.09	2.07	31.4	-	-	P	V
			540.1	30.78	-15.22	46	33.96	24.52	3.24	30.94	-	-	P	V
			659.8	34.65	-11.35	46	35.84	26	3.57	30.76	-	-	P	V
			780.2	35.14	-10.86	46	34.36	27.5	3.9	30.62	-	-	P	V
													V	
													V	
													V	
													V	
													V	
													V	
Remark	1. No other spurious found. 2. All results are PASS against limit line.													



. Emission below 1GHz

5GHz WIFI 802.11ac VHT40 (LF @ 3m)

WIFI Ant. 1+2	Note	Frequency (MHz)	Level (dBμV/m)	Over Limit (dB)	Limit Line (dBμV/m)	Read Level (dBμV)	Antenna Factor (dB/m)	Cable Loss (dB)	Preamp Factor (dB)	Ant Pos (cm)	Table Pos (deg)	Peak Avg. (P/A)	Pol. (H/V)	
5GHz 802.11ac VHT40 LF		30.27	29.4	-10.6	40	33.68	26	1.07	31.35	-	-	P	H	
		101.82	33.66	-9.84	43.5	47.05	16.58	1.55	31.52	-	-	P	H	
		240.06	31.87	-14.13	46	43.11	18.09	2.07	31.4	-	-	P	H	
		540.1	35.01	-10.99	46	38.19	24.52	3.24	30.94	-	-	P	H	
		659.8	38.79	-7.21	46	39.98	26	3.57	30.76	-	-	P	H	
		780.2	38.85	-7.15	46	38.07	27.5	3.9	30.62	100	0	P	H	
														H
														H
														H
														H
														H
														H
			35.4	32.61	-7.39	40	40.25	22.72	1.07	31.43	100	0	P	V
			99.66	31.87	-11.63	43.5	45.71	16.4	1.28	31.52	-	-	P	V
			240.06	29.88	-16.12	46	41.12	18.09	2.07	31.4	-	-	P	V
			420.4	25.81	-20.19	46	31.38	22.68	2.89	31.14	-	-	P	V
			659.8	33.88	-12.12	46	35.07	26	3.57	30.76	-	-	P	V
			839	33.55	-12.45	46	31.54	28.48	4.1	30.57	-	-	P	V
													V	
													V	
													V	
													V	
													V	
													V	
Remark	1. No other spurious found. 2. All results are PASS against limit line.													



Emission below 1GHz

5GHz WIFI 802.11ac VHT80 (LF @ 3m)

WIFI Ant. 1+2	Note	Frequency (MHz)	Level (dBμV/m)	Over Limit (dB)	Limit Line (dBμV/m)	Read Level (dBμV)	Antenna Factor (dB/m)	Cable Loss (dB)	Preamp Factor (dB)	Ant Pos (cm)	Table Pos (deg)	Peak Avg. (P/A)	Pol. (H/V)	
5GHz 802.11ac VHT80 LF		30	28.3	-11.7	40	32.58	26	1.07	31.35	-	-	P	H	
		101.82	34.81	-8.69	43.5	48.2	16.58	1.55	31.52	-	-	P	H	
		240.06	32.15	-13.85	46	43.39	18.09	2.07	31.4	-	-	P	H	
		540.1	35.71	-10.29	46	38.89	24.52	3.24	30.94	-	-	P	H	
		659.8	39.41	-6.59	46	40.6	26	3.57	30.76	-	-	P	H	
		780.2	39.57	-6.43	46	38.79	27.5	3.9	30.62	100	0	P	H	
														H
														H
														H
														H
														H
														H
			34.59	32.52	-7.48	40	39.56	23.3	1.07	31.41	100	0	P	V
			98.58	31.57	-11.93	43.5	45.54	16.27	1.28	31.52	-	-	P	V
			240.06	29.82	-16.18	46	41.06	18.09	2.07	31.4	-	-	P	V
			540.1	32.72	-13.28	46	35.9	24.52	3.24	30.94	-	-	P	V
			659.8	34.2	-11.8	46	35.39	26	3.57	30.76	-	-	P	V
			780.2	36.15	-9.85	46	35.37	27.5	3.9	30.62	-	-	P	V
													V	
													V	
													V	
													V	
													V	
													V	

Remark

- No other spurious found.
- All results are PASS against limit line.



Note symbol

*	Fundamental Frequency which can be ignored. However, the level of any unwanted emissions shall not exceed the level of the fundamental frequency.
!	Test result is over limit line.
P/A	Peak or Average
H/V	Horizontal or Vertical



A calculation example for radiated spurious emission is shown as below:

WIFI Ant. 1+2	Note	Frequency (MHz)	Level (dBμV/m)	Over Limit (dB)	Limit Line (dBμV/m)	Read Level (dBμV)	Antenna Factor (dB/m)	Cable Loss (dB)	Preamp Factor (dB)	Ant Pos (cm)	Table Pos (deg)	Peak Avg. (P/A)	Pol. (H/V)
802.11b CH 01 2412MHz		2390	55.45	-18.55	74	54.51	32.22	4.58	35.86	103	308	P	H
		2390	43.54	-10.46	54	42.6	32.22	4.58	35.86	103	308	A	H

- 1. Level(dBμV/m) =
Antenna Factor(dB/m) + Cable Loss(dB) + Read Level(dBμV) - Preamp Factor(dB)
- 2. Over Limit(dB) = Level(dBμV/m) – Limit Line(dBμV/m)

For Peak Limit @ 2390MHz:

- 1. Level(dBμV/m)
= Antenna Factor(dB/m) + Cable Loss(dB) + Read Level(dBμV) - Preamp Factor(dB)
= 32.22(dB/m) + 4.58(dB) + 54.51(dBμV) – 35.86 (dB)
= 55.45 (dBμV/m)
- 2. Over Limit(dB)
= Level(dBμV/m) – Limit Line(dBμV/m)
= 55.45(dBμV/m) – 74(dBμV/m)
= -18.55(dB)

For Average Limit @ 2390MHz:

- 1. Level(dBμV/m)
= Antenna Factor(dB/m) + Cable Loss(dB) + Read Level(dBμV) - Preamp Factor(dB)
= 32.22(dB/m) + 4.58(dB) + 42.6(dBμV) – 35.86 (dB)
= 43.54 (dBμV/m)
- 2. Over Limit(dB)
= Level(dBμV/m) – Limit Line(dBμV/m)
= 43.54(dBμV/m) – 54(dBμV/m)
= -10.46(dB)

Both peak and average measured complies with the limit line, so test result is “PASS”.



Appendix C. Radiated Spurious Emission

Test Engineer :	Jesse Wang, James Chiu, Derek Hsu, and Luke Chang	Temperature :	21~24°C
		Relative Humidity :	54~55%

Note symbol

-L	Low channel location
-R	High channel location



<CDD Mode>

Band 3 - 5470~5725MHz

WIFI 802.11a (Band Edge @ 3m)

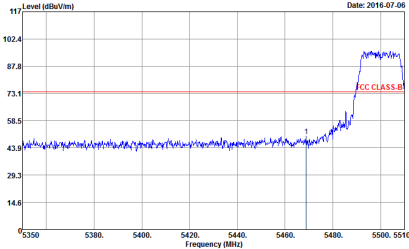
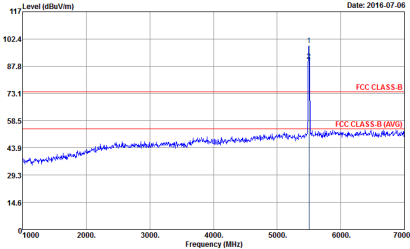
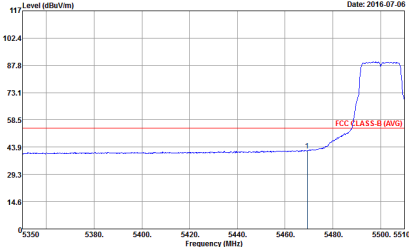
WIFI	Band 3 5470~5725MHz Band Edge @ 3m	
ANT	802.11a CH100 5500MHz	
2	Horizontal	Fundamental
Peak	 <p>Site : 03CH07-HY Condition : FCC CLASS B 3m HF-ANT_130829 HORIZONTAL Detector : Peak Project : 660115 Mode : 100</p>	 <p>Site : 03CH07-HY Condition : FCC CLASS B 3m HF-ANT_130829 HORIZONTAL Detector : Peak Project : 660115 Mode : 100</p>
Avg.	 <p>Site : 03CH07-HY Condition : FCC CLASS B (AVG) 3m HF-ANT_130829 HORIZONTAL Detector : Peak Project : 660115 Mode : 100</p>	Left blank

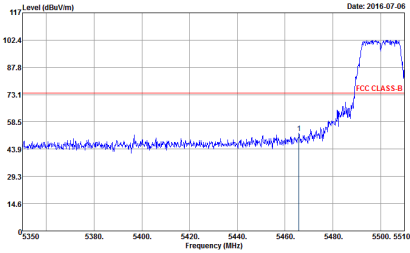
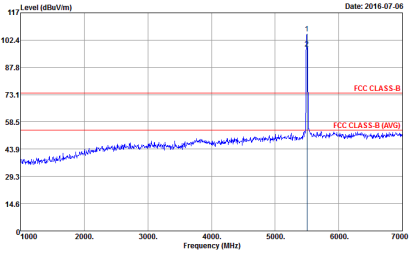
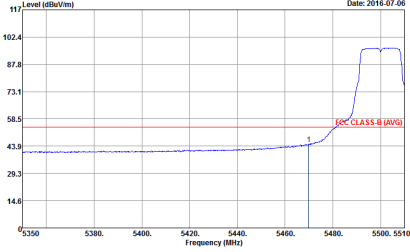

WIFI	Band 3 5470~5725MHz Band Edge @ 3m	
ANT	802.11a CH100 5500MHz	
2	Vertical	Fundamental
Peak	 <p>Date: 2016-07-06</p> <p>Site : 03CH07-HY Condition : FCC CLASS-B 3m HF-ANT_130829 VERTICAL RBW:1000 000kHz VBW:3000 000kHz SVT:Auto Detector : Peak Project : 660115 Mode : 100</p>	 <p>Date: 2016-07-06</p> <p>Site : 03CH07-HY Condition : FCC CLASS-B 3m HF-ANT_130829 VERTICAL RBW:1000 000kHz VBW:3000 000kHz SVT:Auto Detector : Peak Project : 660115 Mode : 100</p>
Avg.	 <p>Date: 2016-07-06</p> <p>Site : 03CH07-HY Condition : FCC CLASS-B (AVG) 3m HF-ANT_130829 VERTICAL RBW:1000 000kHz VBW:1 000kHz SVT:Auto Detector : Peak Project : 660115 Mode : 100</p>	Left blank



WIFI	Band 3 5470~5725MHz Band Edge @ 3m	
ANT	802.11a CH116 5580MHz - L	
2	Horizontal	Fundamental
Peak	<p>Site : 03CH07-HY Condition : FCC CLASS-B 3m HF-ANT_130829 HORIZONTAL Detector : Peak Project : 660115 Mode : 101</p>	<p>Site : 03CH07-HY Condition : FCC CLASS-B 3m HF-ANT_130829 HORIZONTAL Detector : Peak Project : 660115 Mode : 101</p>
Avg.	<p>Site : 03CH07-HY Condition : FCC CLASS-B (AVG) 3m HF-ANT_130829 HORIZONTAL Detector : Peak Project : 660115 Mode : 101</p>	Left blank

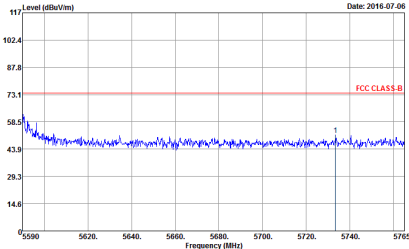
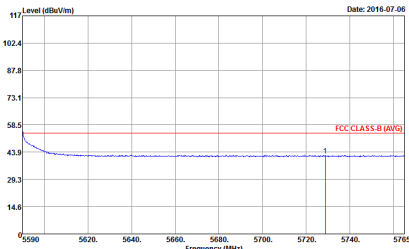

WIFI	Band 3 5470~5725MHz Band Edge @ 3m	
ANT	802.11a CH116 5580MHz - R	
2	Horizontal	Fundamental
Peak	 <p>Site : 03CH07HY Condition : FCC CLASS-B 3m HF-ANT_130829 HORIZONTAL RBW:1000.000kHz VBW:3000.000kHz SVWT:Auto Detector : Peak Project : 660115 Mode : 101</p>	Left blank
Avg.	 <p>Site : 03CH07HY Condition : FCC CLASS-B (AVG) 3m HF-ANT_130829 HORIZONTAL RBW:1000.000kHz VBW:1.000kHz SVWT:Auto Detector : Peak Project : 660115 Mode : 101</p>	Left blank

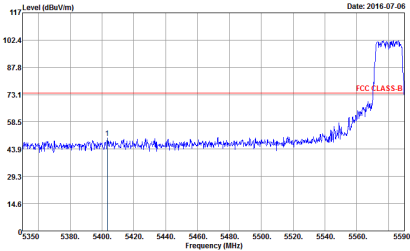
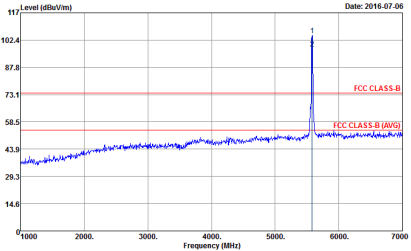
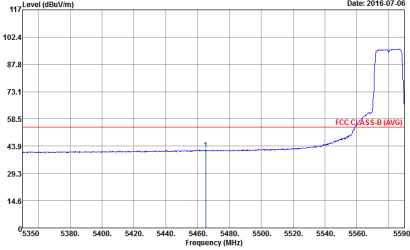

WIFI	Band 3 5470~5725MHz Band Edge @ 3m	
ANT	802.11a CH116 5580MHz - L	
2	Vertical	Fundamental
Peak	 <p>Date: 2016-07-06</p> <p>Site : 03CH07-HY Condition : FCC CLASS-B 3m HF-ANT_130829 VERTICAL RBW:1000 000kHz VBW:3000 000kHz SVWT:Auto Detector : Peak Project : 660115 Mode : 101</p>	 <p>Date: 2016-07-06</p> <p>Site : 03CH07-HY Condition : FCC CLASS-B 3m HF-ANT_130829 VERTICAL RBW:1000 000kHz VBW:3000 000kHz SVWT:Auto Detector : Peak Project : 660115 Mode : 101</p>
Avg.	 <p>Date: 2016-07-06</p> <p>Site : 03CH07-HY Condition : FCC CLASS-B (AVG) 3m HF-ANT_130829 VERTICAL RBW:1000 000kHz VBW:1 000kHz SVWT:Auto Detector : Peak Project : 660115 Mode : 101</p>	Left blank

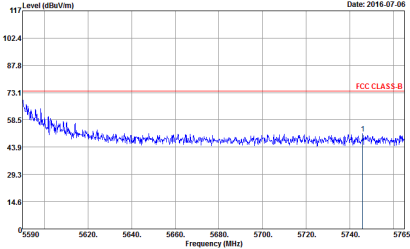
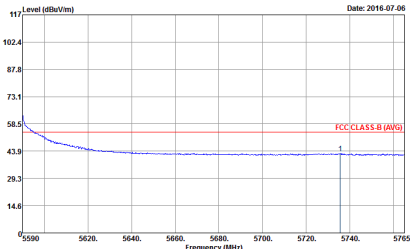

WIFI	Band 3 5470~5725MHz Band Edge @ 3m	
ANT	802.11a CH116 5580MHz - R	
2	Vertical	Fundamental
Peak	 <p>Date: 2016-07-06</p> <p>Site : 03CH07-HY Condition : FCC CLASS-B 3m HF-ANT_130829 VERTICAL RBW:1000.000kHz VBW:3000.000kHz SWT:Auto Detector : Peak Project : 660115 Mode : 101</p>	Left blank
Avg.	 <p>Date: 2016-07-06</p> <p>Site : 03CH07-HY Condition : FCC CLASS-B (AVG) 3m HF-ANT_130829 VERTICAL RBW:1000.000kHz VBW:1.000kHz SWT:Auto Detector : Peak Project : 660115 Mode : 101</p>	Left blank

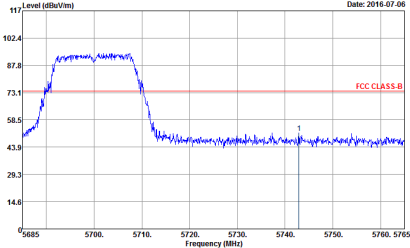
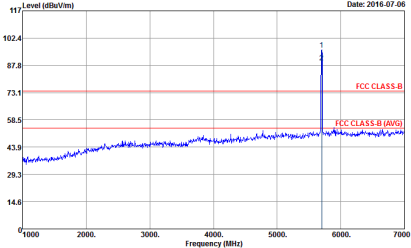
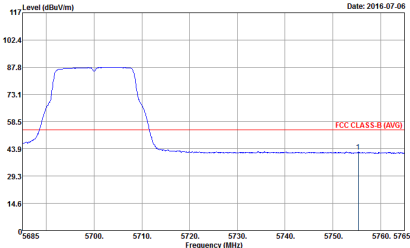

WIFI	Band 3 5470~5725MHz Band Edge @ 3m	
ANT	802.11a CH140 5700MHz	
2	Horizontal	Fundamental
Peak	 <p>Date: 2016-07-06</p> <p>Site : 03CH07-HY Condition : FCC CLASS-B 3m HF-ANT_130829 HORIZONTAL : RBW:1000.000kHz VBW:3000.000kHz SVWT:Auto Detector : Peak Project : 660115 Mode : 102</p>	 <p>Date: 2016-07-06</p> <p>Site : 03CH07-HY Condition : FCC CLASS-B 3m HF-ANT_130829 HORIZONTAL : RBW:1000.000kHz VBW:3000.000kHz SVWT:Auto Detector : Peak Project : 660115 Mode : 102</p>
Avg.	 <p>Date: 2016-07-06</p> <p>Site : 03CH07-HY Condition : FCC CLASS-B (AVG) 3m HF-ANT_130829 HORIZONTAL : RBW:1000.000kHz VBW:1.000kHz SVWT:Auto Detector : Peak Project : 660115 Mode : 102</p>	Left blank

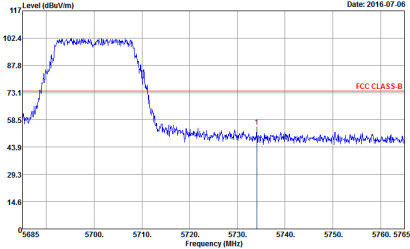
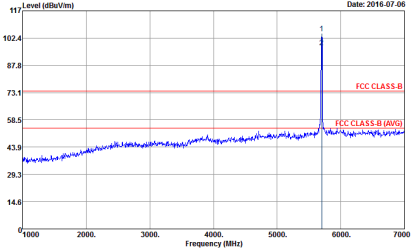
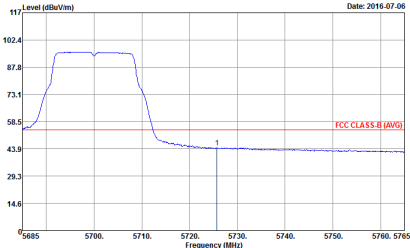

WIFI	Band 3 5470~5725MHz Band Edge @ 3m	
ANT	802.11a CH140 5700MHz	
2	Vertical	Fundamental
Peak	 <p>Date: 2016-07-06</p> <p>Site : 03CH07-HY Condition : FCC CLASS-B 3m HF-ANT_130829 VERTICAL RBW:1000.000kHz VBW:3000.000kHz SVT:Auto Detector : Peak Project : 660115 Mode : 102</p>	 <p>Date: 2016-07-06</p> <p>Site : 03CH07-HY Condition : FCC CLASS-B 3m HF-ANT_130829 VERTICAL RBW:1000.000kHz VBW:3000.000kHz SVT:Auto Detector : Peak Project : 660115 Mode : 102</p>
Avg.	 <p>Date: 2016-07-06</p> <p>Site : 03CH07-HY Condition : FCC CLASS-B (AVG) 3m HF-ANT_130829 VERTICAL RBW:1000.000kHz VBW:1.000kHz SVT:Auto Detector : Peak Project : 660115 Mode : 102</p>	Left blank



Band 3 5470~5725MHz
WIFI 802.11ac VHT20 (Band Edge @ 3m)

WIFI	Band 3 5470~5725MHz Band Edge @ 3m	
ANT	802.11ac VHT20 CH100 5500MHz	
2	Horizontal	Fundamental
<p>Peak</p>	<p>Site : 03CH07-HY Condition : FCC CLASS-B 3m HF-ANT_130829 HORIZONTAL RBW:1000.000kHz VBW:3000.000kHz SWT:Auto Detector : Peak Project : 660115 Mode : 103</p>	<p>Site : 03CH07-HY Condition : FCC CLASS-B 3m HF-ANT_130829 HORIZONTAL RBW:1000.000kHz VBW:3000.000kHz SWT:Auto Detector : Peak Project : 660115 Mode : 103</p>
<p>Avg.</p>	<p>Site : 03CH07-HY Condition : FCC CLASS-B (AVG) 3m HF-ANT_130829 HORIZONTAL RBW:1000.000kHz VBW:1.000kHz SWT:Auto Detector : Peak Project : 660115 Mode : 103</p>	<p align="center">Left blank</p>

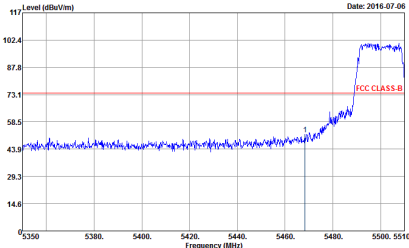
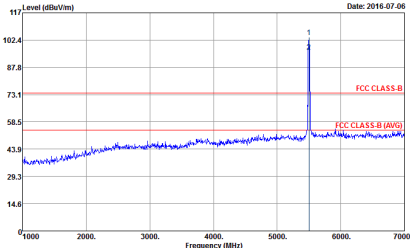
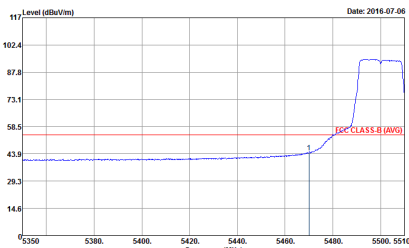

WIFI	Band 3 5470~5725MHz Band Edge @ 3m	
ANT	802.11ac VHT20 CH100 5500MHz	
2	Vertical	Fundamental
Peak	 <p>Date: 2016-07-06</p> <p>Site : 03CH07-HY Condition : FCC CLASS-B 3m HF-ANT_130829 VERTICAL : RBW:1000.000kHz VBW:3000.000kHz SWT:Auto Detector : Peak Project : 660115 Mode : 103</p>	 <p>Date: 2016-07-06</p> <p>Site : 03CH07-HY Condition : FCC CLASS-B 3m HF-ANT_130829 VERTICAL : RBW:1000.000kHz VBW:3000.000kHz SWT:Auto Detector : Peak Project : 660115 Mode : 103</p>
Avg.	 <p>Date: 2016-07-06</p> <p>Site : 03CH07-HY Condition : FCC CLASS-B (AVG) 3m HF-ANT_130829 VERTICAL : RBW:1000.000kHz VBW:1.000kHz SWT:Auto Detector : Peak Project : 660115 Mode : 103</p>	Left blank

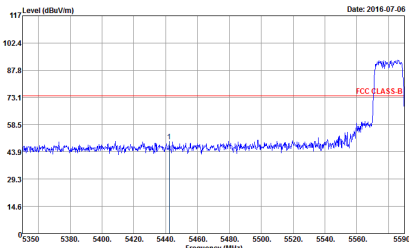
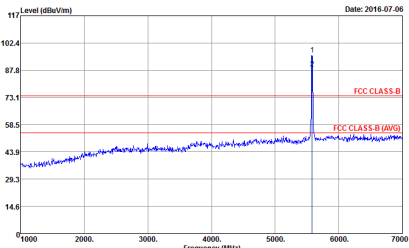
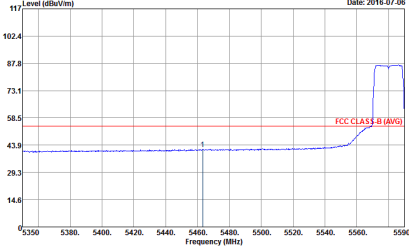

WIFI	Band 3 5470~5725MHz Band Edge @ 3m	
ANT	802.11ac VHT20 CH116 5580MHz - L	
2	Horizontal	Fundamental
Peak	 <p>Date: 2016-07-06</p> <p>Site : 03CH07-HY Condition : FCC CLASS B 3m HF-ANT_130829 HORIZONTAL Detector : Peak Project : 660115 Mode : 104</p>	 <p>Date: 2016-07-06</p> <p>Site : 03CH07-HY Condition : FCC CLASS B 3m HF-ANT_130829 HORIZONTAL Detector : Peak Project : 660115 Mode : 104</p>
Avg.	 <p>Date: 2016-07-06</p> <p>Site : 03CH07-HY Condition : FCC CLASS B (AVG) 3m HF-ANT_130829 HORIZONTAL Detector : Peak Project : 660115 Mode : 104</p>	Left blank

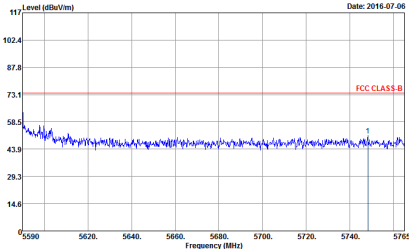
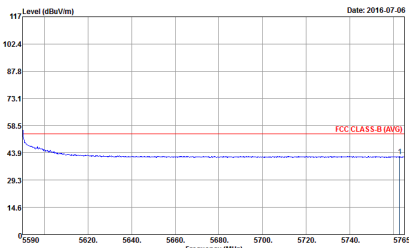

WIFI	Band 3 5470~5725MHz Band Edge @ 3m	
ANT	802.11ac VHT20 CH116 5580MHz - R	
2	Horizontal	Fundamental
Peak	 <p>Site : 03CH07-HY Condition : FCC CLASS-B 3m HF-ANT_130829 HORIZONTAL RBW:1000.000kHz VBW:3000.000kHz SVWT:Auto Detector : Peak Project : 660115 Mode : 104</p>	Left blank
Avg.	 <p>Site : 03CH07-HY Condition : FCC CLASS-B (AVG) 3m HF-ANT_130829 HORIZONTAL RBW:1000.000kHz VBW:1.000kHz SVWT:Auto Detector : Peak Project : 660115 Mode : 104</p>	Left blank

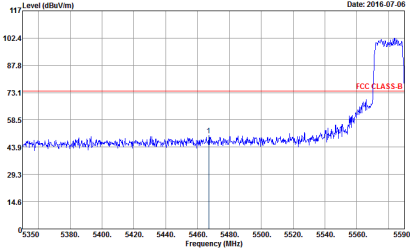
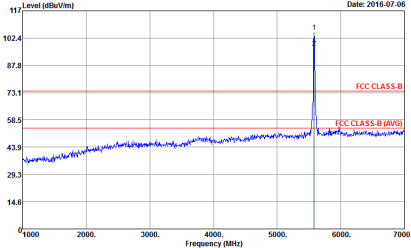
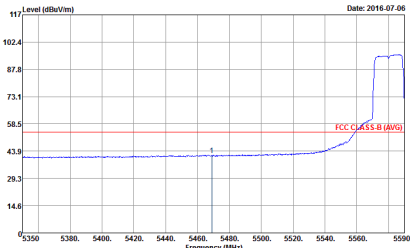

WIFI	Band 3 5470~5725MHz Band Edge @ 3m	
ANT	802.11ac VHT20 CH116 5580MHz - L	
2	Vertical	Fundamental
Peak	 <p>Date: 2016-07-06</p> <p>Site : 03CH07-HY Condition : FCC CLASS-B 3m HF-ANT_130829 VERTICAL RBW:1000 000kHz VBW:3000 000kHz SVWT:Auto Detector : Peak Project : 660115 Mode : 104</p>	 <p>Date: 2016-07-06</p> <p>Site : 03CH07-HY Condition : FCC CLASS-B 3m HF-ANT_130829 VERTICAL RBW:1000 000kHz VBW:3000 000kHz SVWT:Auto Detector : Peak Project : 660115 Mode : 104</p>
Avg.	 <p>Date: 2016-07-06</p> <p>Site : 03CH07-HY Condition : FCC CLASS-B (AVG) 3m HF-ANT_130829 VERTICAL RBW:1000 000kHz VBW:1 000kHz SVWT:Auto Detector : Peak Project : 660115 Mode : 104</p>	Left blank

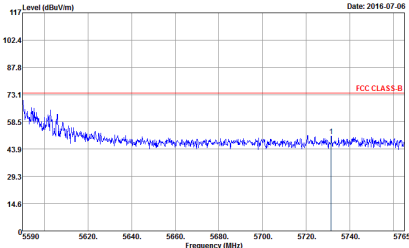
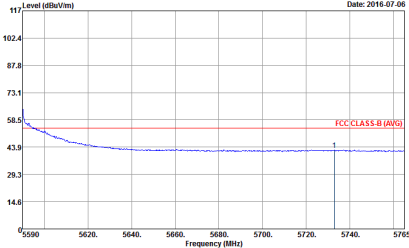

WIFI	Band 3 5470~5725MHz Band Edge @ 3m	
ANT	802.11ac VHT20 CH116 5580MHz - R	
2	Vertical	Fundamental
Peak	 <p>Date: 2016-07-06</p> <p>Site : 03CH07-HY Condition : FCC CLASS-B 3m HF-ANT_130829 VERTICAL : RBW:1000.000kHz VBW:3000.000kHz SWT:Auto Detector : Peak Project : 660115 Mode : 104</p>	Left blank
Avg.	 <p>Date: 2016-07-06</p> <p>Site : 03CH07-HY Condition : FCC CLASS-B (AVG) 3m HF-ANT_130829 VERTICAL : RBW:1000.000kHz VBW:1.000kHz SWT:Auto Detector : Peak Project : 660115 Mode : 104</p>	Left blank

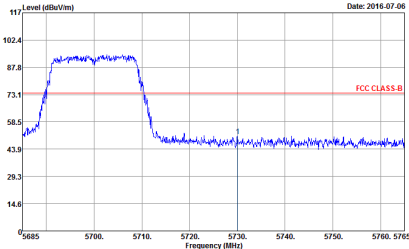
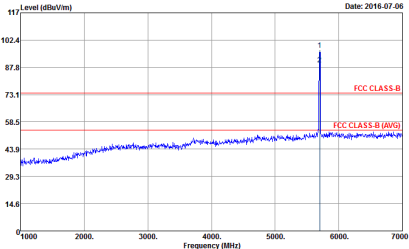
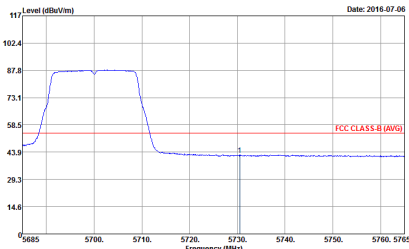

WIFI	Band 3 5470~5725MHz Band Edge @ 3m	
ANT	802.11ac VHT20 CH140 5700MHz	
2	Horizontal	Fundamental
Peak	 <p>Site : 03CH07-HY Condition : FCC CLASS-B 3m HF-ANT_130829 HORIZONTAL RBW:1000 000kHz VBW:3000 000kHz SVWT:Auto Detector : Peak Project : 660115 Mode : 105</p>	 <p>Site : 03CH07-HY Condition : FCC CLASS-B 3m HF-ANT_130829 HORIZONTAL RBW:1000 000kHz VBW:3000 000kHz SVWT:Auto Detector : Peak Project : 660115 Mode : 105</p>
Avg.	 <p>Site : 03CH07-HY Condition : FCC CLASS-B (AVG) 3m HF-ANT_130829 HORIZONTAL RBW:1000 000kHz VBW:1 000kHz SVWT:Auto Detector : Peak Project : 660115 Mode : 105</p>	Left blank

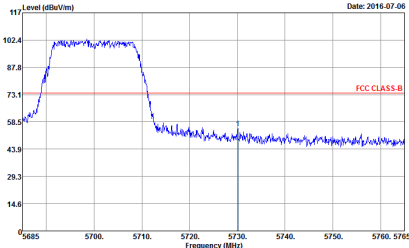
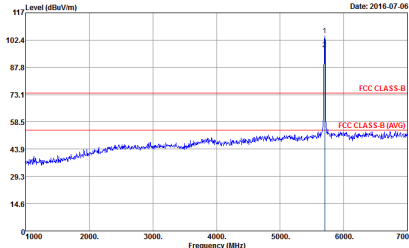
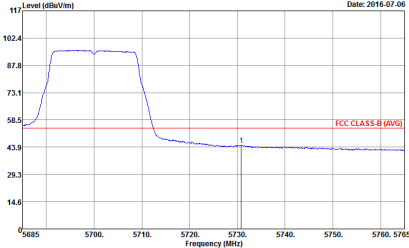

WIFI	Band 3 5470~5725MHz Band Edge @ 3m	
ANT	802.11ac VHT20 CH140 5700MHz	
2	Vertical	Fundamental
Peak	 <p>Date: 2016-07-06</p> <p>Site : 03CH07-HY Condition : FCC CLASS-B 3m HF-ANT_130829 VERTICAL : RBW:1000.000kHz VBW:3000.000kHz SWT:Auto Detector : Peak Project : 660115 Mode : 105</p>	 <p>Date: 2016-07-06</p> <p>Site : 03CH07-HY Condition : FCC CLASS-B 3m HF-ANT_130829 VERTICAL : RBW:1000.000kHz VBW:3000.000kHz SWT:Auto Detector : Peak Project : 660115 Mode : 105</p>
Avg.	 <p>Date: 2016-07-06</p> <p>Site : 03CH07-HY Condition : FCC CLASS-B (AVG) 3m HF-ANT_130829 VERTICAL : RBW:1000.000kHz VBW:1.000kHz SWT:Auto Detector : Peak Project : 660115 Mode : 105</p>	Left blank



**Band 3 5470~5725MHz
WIFI 802.11ac VHT40 (Band Edge @ 3m)**

WIFI	Band 3 5470~5725MHz Band Edge @ 3m	
ANT	802.11ac VHT40 CH102 5510MHz - L	
2	Horizontal	Fundamental
<p>Peak</p>	<p>Site : 03CH07HY Condition : FCC CLASS B 3m HF-ANT_130829 HORIZONTAL Detector : Peak Project : 660115 Mode : 106</p>	<p>Site : 03CH07HY Condition : FCC CLASS B 3m HF-ANT_130829 HORIZONTAL Detector : Peak Project : 660115 Mode : 106</p>
<p>Avg.</p>	<p>Site : 03CH07HY Condition : FCC CLASS B (AVG) 3m HF-ANT_130829 HORIZONTAL Detector : Peak Project : 660115 Mode : 106</p>	<p align="center">Left blank</p>

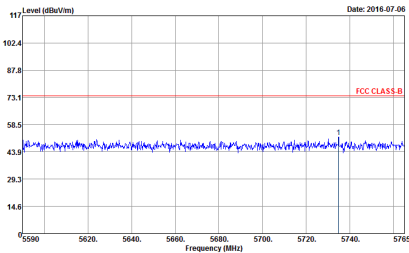
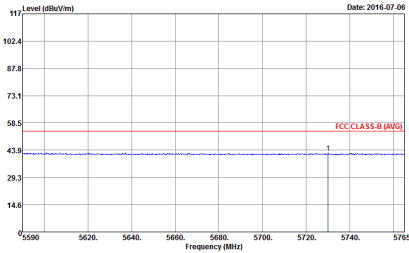

WIFI	Band 3 5470~5725MHz Band Edge @ 3m	
ANT	802.11ac VHT40 CH102 5510MHz - R	
2	Horizontal	Fundamental
Peak	 <p>Site : 03CH07-HY Condition : FCC CLASS-B 3m HF-ANT_130829 HORIZONTAL Detector : Peak Project : 660115 Mode : 106</p>	Left blank
Avg.	 <p>Site : 03CH07-HY Condition : FCC CLASS-B (AVG) 3m HF-ANT_130829 HORIZONTAL Detector : Peak Project : 660115 Mode : 106</p>	Left blank



WIFI	Band 3 5470~5725MHz Band Edge @ 3m	
ANT	802.11ac VHT40 CH102 5510MHz - L	
2	Vertical	Fundamental
Peak	<p>Date: 2016.07.06</p> <p>Site : 03CH07-HY Condition : FCC CLASS-B 3m HF-ANT_130829 VERTICAL RBW:1000.000kHz VBW:3000.000kHz SWT:Auto Detector : Peak Project : 660115 Mode : 106</p>	<p>Date: 2016.07.06</p> <p>Site : 03CH07-HY Condition : FCC CLASS-B 3m HF-ANT_130829 VERTICAL RBW:1000.000kHz VBW:3000.000kHz SWT:Auto Detector : Peak Project : 660115 Mode : 106</p>
Avg.	<p>Date: 2016.07.06</p> <p>Site : 03CH07-HY Condition : FCC CLASS-B (AVG) 3m HF-ANT_130829 VERTICAL RBW:1000.000kHz VBW:2.000kHz SWT:Auto Detector : Peak Project : 660115 Mode : 106</p>	Left blank

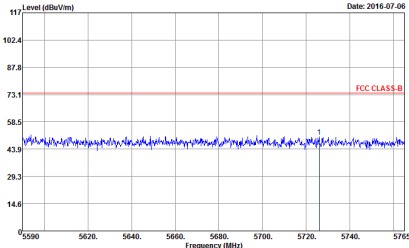
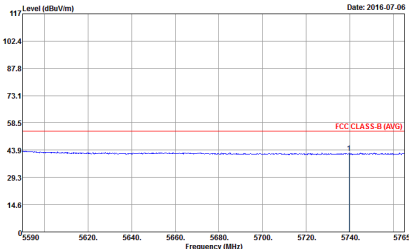

WIFI	Band 3 5470~5725MHz Band Edge @ 3m	
ANT	802.11ac VHT40 CH102 5510MHz - R	
2	Vertical	Fundamental
Peak		Left blank
Avg.		Left blank

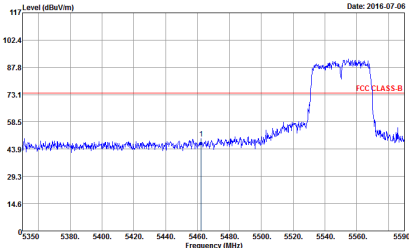
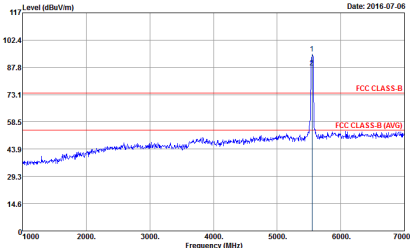
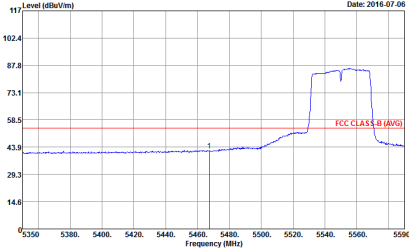

WIFI	Band 3 5470~5725MHz Band Edge @ 3m	
ANT	802.11ac VHT40 CH110 5550MHz - L	
2	Horizontal	Fundamental
<p>Peak</p>	 <p>Date: 2016-07-06</p> <p>Site : 03CH07-HY Condition : FCC CLASS-B 3m HF-ANT_130829 HORIZONTAL : RBW:1000.000kHz VBW:3000.000kHz SVWT:Auto Detector : Peak Project : 660115 Mode : 107</p>	 <p>Date: 2016-07-06</p> <p>Site : 03CH07-HY Condition : FCC CLASS-B 3m HF-ANT_130829 HORIZONTAL : RBW:1000.000kHz VBW:3000.000kHz SVWT:Auto Detector : Peak Project : 660115 Mode : 107</p>
<p>Avg.</p>	 <p>Date: 2016-07-06</p> <p>Site : 03CH07-HY Condition : FCC CLASS-B (AVG) 3m HF-ANT_130829 HORIZONTAL : RBW:1000.000kHz VBW:2.000kHz SVWT:Auto Detector : Peak Project : 660115 Mode : 107</p>	<p>Left blank</p>

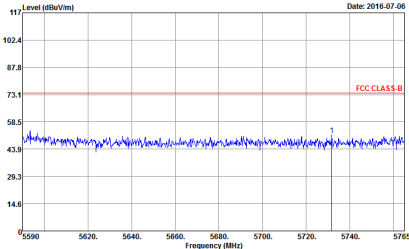
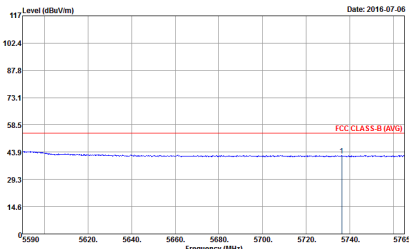

WIFI	Band 3 5470~5725MHz Band Edge @ 3m	
ANT	802.11ac VHT40 CH110 5550MHz - R	
2	Horizontal	Fundamental
Peak	 <p>Site : 03CH07HY Condition : FCC CLASS-B 3m HF-ANT_130829 HORIZONTAL RBW:1000.000kHz VBW:3000.000kHz SVT:Auto Detector : Peak Project : 660115 Mode : 107</p>	Left blank
Avg.	 <p>Site : 03CH07HY Condition : FCC CLASS-B (AVG) 3m HF-ANT_130829 HORIZONTAL RBW:1000.000kHz VBW:1.000kHz SVT:Auto Detector : Peak Project : 660115 Mode : 107</p>	Left blank



WIFI	Band 3 5470~5725MHz Band Edge @ 3m	
ANT	802.11ac VHT40 CH110 5550MHz - L	
2	Vertical	Fundamental
<p>Peak</p>	<p>Date: 2016.07.06</p> <p>Site : 03CH07-HY Condition : FCC CLASS-B 3m HF-ANT_130829 VERTICAL : RBW:1000.000kHz VBW:3000.000kHz SWT:Auto Detector : Peak Project : 660115 Mode : 107</p>	<p>Date: 2016.07.06</p> <p>Site : 03CH07-HY Condition : FCC CLASS-B 3m HF-ANT_130829 VERTICAL : RBW:1000.000kHz VBW:3000.000kHz SWT:Auto Detector : Peak Project : 660115 Mode : 107</p>
<p>Avg.</p>	<p>Date: 2016.07.06</p> <p>Site : 03CH07-HY Condition : FCC CLASS-B (AVG) 3m HF-ANT_130829 VERTICAL : RBW:1000.000kHz VBW:2.000kHz SWT:Auto Detector : Peak Project : 660115 Mode : 107</p>	<p>Left blank</p>



WIFI	Band 3 5470~5725MHz Band Edge @ 3m	
ANT	802.11ac VHT40 CH110 5550MHz - R	
2	Vertical	Fundamental
Peak	<p>Site : 03CH07-HY Condition : FCC CLASS-B 3m HF-ANT_130829 VERTICAL : RBW:1000.000kHz VBW:3000.000kHz SWT:Auto Detector : Peak Project : 660115 Mode : 107</p>	Left blank
Avg.	<p>Site : 03CH07-HY Condition : FCC CLASS-B (AVG) 3m HF-ANT_130829 VERTICAL : RBW:1000.000kHz VBW:1.000kHz SWT:Auto Detector : Peak Project : 660115 Mode : 107</p>	Left blank

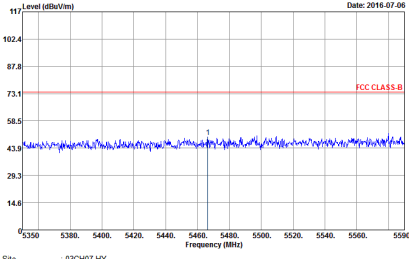
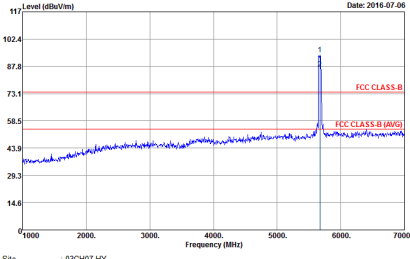
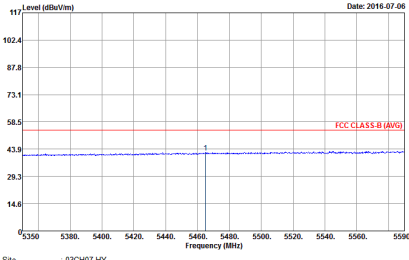

WIFI	Band 3 5470~5725MHz Band Edge @ 3m	
ANT	802.11ac VHT40 CH134 5670MHz - L	
2	Horizontal	Fundamental
Peak	 <p>Date: 2016-07-06</p> <p>Site : 03CH07-HY Condition : FCC CLASS-B 3m HF-ANT_130829 HORIZONTAL RBW:1000.000kHz VBW:3000.000kHz SWT:Auto Detector : Peak Project : 660115 Mode : 108</p>	 <p>Date: 2016-07-06</p> <p>Site : 03CH07-HY Condition : FCC CLASS-B 3m HF-ANT_130829 HORIZONTAL RBW:1000.000kHz VBW:3000.000kHz SWT:Auto Detector : Peak Project : 660115 Mode : 108</p>
Avg.	 <p>Date: 2016-07-06</p> <p>Site : 03CH07-HY Condition : FCC CLASS-B (AVG) 3m HF-ANT_130829 HORIZONTAL RBW:1000.000kHz VBW:2.000kHz SWT:Auto Detector : Peak Project : 660115 Mode : 108</p>	Left blank

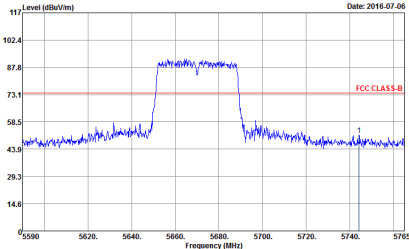
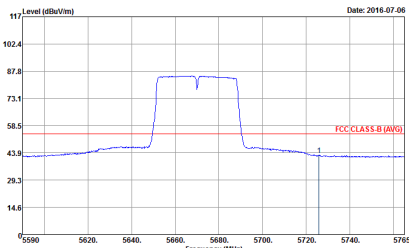

WIFI	Band 3 5470~5725MHz Band Edge @ 3m	
ANT	802.11ac VHT40 CH134 5670MHz - R	
2	Horizontal	Fundamental
Peak	 <p>Date: 2016-07-06</p> <p>Site : 03CH07-HY Condition : FCC CLASS-B 3m HF-ANT_130829 HORIZONTAL RBW:1000.000kHz VBW:3000.000kHz SVWT:Auto Detector : Peak Project : 660115 Mode : 108</p>	Left blank
Avg.	 <p>Date: 2016-07-06</p> <p>Site : 03CH07-HY Condition : FCC CLASS-B (AVG) 3m HF-ANT_130829 HORIZONTAL RBW:1000.000kHz VBW:1.000kHz SVWT:Auto Detector : Peak Project : 660115 Mode : 108</p>	Left blank

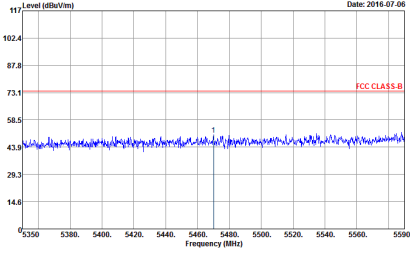
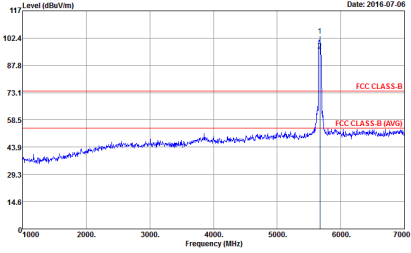
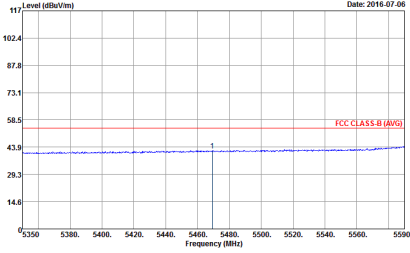

WIFI	Band 3 5470~5725MHz Band Edge @ 3m	
ANT	802.11ac VHT40 CH134 5670MHz - L	
2	Vertical	Fundamental
Peak	 <p>Site : 03CH07-HY Condition : FCC CLASS-B 3m HF-ANT_130829 VERTICAL RBW:1000 000kHz VBW:3000 000kHz SVT:Auto Detector : Peak Project : 660115 Mode : 108</p>	 <p>Site : 03CH07-HY Condition : FCC CLASS-B 3m HF-ANT_130829 VERTICAL RBW:1000 000kHz VBW:3000 000kHz SVT:Auto Detector : Peak Project : 660115 Mode : 108</p>
Avg.	 <p>Site : 03CH07-HY Condition : FCC CLASS-B (AVG) 3m HF-ANT_130829 VERTICAL RBW:1000 000kHz VBW:2 000kHz SVT:Auto Detector : Peak Project : 660115 Mode : 108</p>	Left blank

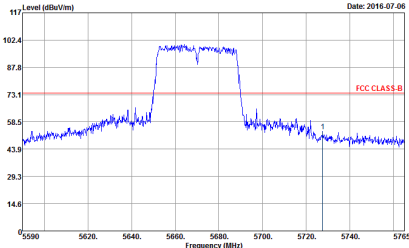
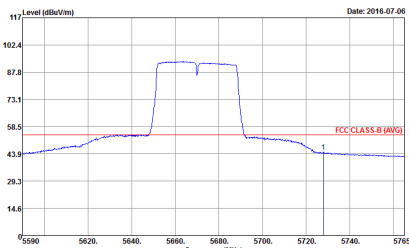

WIFI	Band 3 5470~5725MHz Band Edge @ 3m	
ANT	802.11ac VHT40 CH134 5670MHz - R	
2	Vertical	Fundamental
Peak	 <p>Date: 2016.07.06</p> <p>Site : 03CH07-HY Condition : FCC CLASS-B 3m HF-ANT_130829 VERTICAL : RBW:1000.000kHz VBW:3000.000kHz SVWT:Auto Detector : Peak Project : 660115 Mode : 108</p>	Left blank
Avg.	 <p>Date: 2016.07.06</p> <p>Site : 03CH07-HY Condition : FCC CLASS-B (AVG) 3m HF-ANT_130829 VERTICAL : RBW:1000.000kHz VBW:1.000kHz SVWT:Auto Detector : Peak Project : 660115 Mode : 108</p>	Left blank

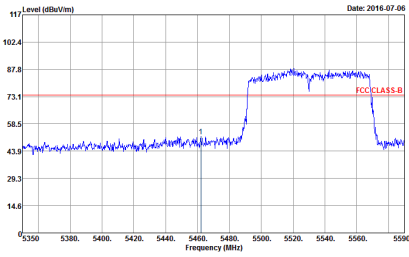
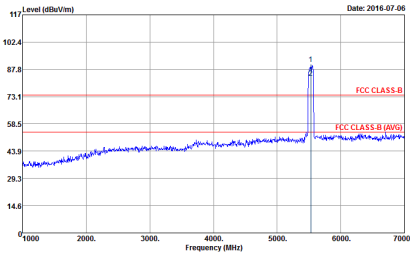
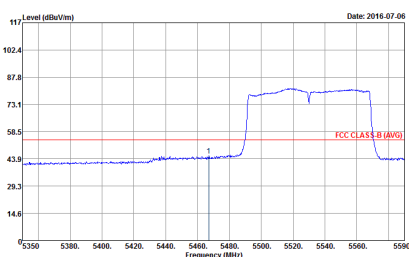

Band 3 5470~5725MHz
WIFI 802.11ac VHT80 (Band Edge @ 3m)

WIFI	Band 3 5470~5725MHz Band Edge @ 3m	
ANT	802.11ac VHT80 CH106 5530MHz - L	
2	Horizontal	Fundamental
Peak	 <p>Site : 03CH07-HY Condition : FCC CLASS-B 3m HF-ANT_130829 HORIZONTAL RBW:1000.000kHz VBW:3000.000kHz SWT:Auto Detector : Peak Project : 660115 Mode : 109</p>	 <p>Site : 03CH07-HY Condition : FCC CLASS-B 3m HF-ANT_130829 HORIZONTAL RBW:1000.000kHz VBW:3000.000kHz SWT:Auto Detector : Peak Project : 660115 Mode : 109</p>
Avg.	 <p>Site : 03CH07-HY Condition : FCC CLASS-B (AVG) 3m HF-ANT_130829 HORIZONTAL RBW:1000.000kHz VBW:5.000kHz SWT:Auto Detector : Peak Project : 660115 Mode : 109</p>	Left blank

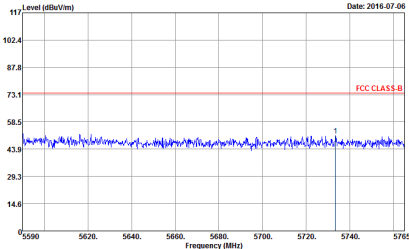
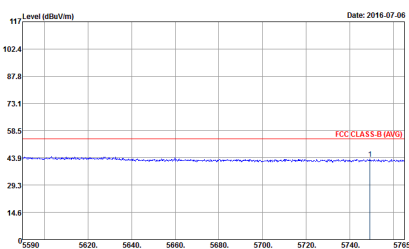

WIFI	Band 3 5470~5725MHz Band Edge @ 3m	
ANT	802.11ac VHT80 CH106 5530MHz - R	
2	Horizontal	Fundamental
Peak	 <p>Site : 03CH07-HY Condition : FCC CLASS-B 3m HF-ANT_130829 HORIZONTAL RBW:1000.000KHz VBW:3000.000KHz SVWT:Auto Detector : Peak Project : 660115 Mode : 109</p>	Left blank
Avg.	 <p>Site : 03CH07-HY Condition : FCC CLASS-B (AVG) 3m HF-ANT_130829 HORIZONTAL RBW:1000.000KHz VBW:5.000KHz SVWT:Auto Detector : Peak Project : 660115 Mode : 109</p>	Left blank



WIFI	Band 3 5470~5725MHz Band Edge @ 3m	
ANT	802.11ac VHT80 CH106 5530MHz - L	
2	Vertical	Fundamental
Peak	<p>Site : 03CH07-HY Condition : FCC CLASS-B 3m HF-ANT_130829 VERTICAL RBW:1000.000kHz VBW:3000.000kHz SVT:Auto Detector : Peak Project : 660115 Mode : 109</p>	<p>Site : 03CH07-HY Condition : FCC CLASS-B 3m HF-ANT_130829 VERTICAL RBW:1000.000kHz VBW:3000.000kHz SVT:Auto Detector : Peak Project : 660115 Mode : 109</p>
Avg.	<p>Site : 03CH07-HY Condition : FCC CLASS-B (AVG) 3m HF-ANT_130829 VERTICAL RBW:1000.000kHz VBW:5.000kHz SVT:Auto Detector : Peak Project : 660115 Mode : 109</p>	Left blank



WIFI	Band 3 5470~5725MHz Band Edge @ 3m	
ANT	802.11ac VHT80 CH106 5530MHz - R	
2	Vertical	Fundamental
Peak	<p>Site : 03CH07-HY Condition : FCC CLASS-B 3m HF-ANT_130829 VERTICAL : RBW:1000.000kHz VBW:3000.000kHz SWT:Auto Detector : Peak Project : 660115 Mode : 109</p>	Left blank
Avg.	<p>Site : 03CH07-HY Condition : FCC CLASS-B (AVG) 3m HF-ANT_130829 VERTICAL : RBW:1000.000kHz VBW:5.000kHz SWT:Auto Detector : Peak Project : 660115 Mode : 109</p>	Left blank

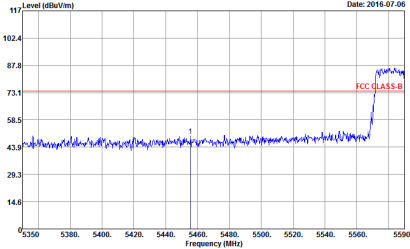
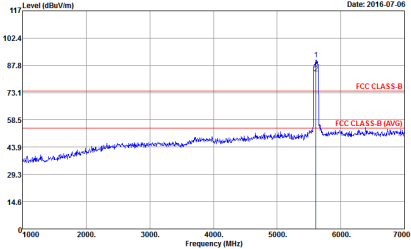
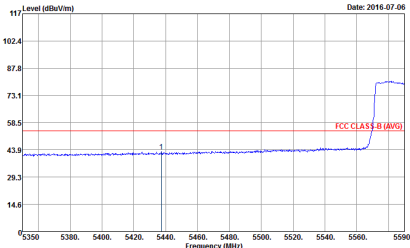

WIFI	Band 3 5470~5725MHz Band Edge @ 3m	
ANT	802.11ac VHT80 CH122 5610MHz - L	
2	Horizontal	Fundamental
Peak	 <p>Date: 2016-07-06</p> <p>Site : 03CH07-HY Condition : FCC CLASS-B 3m HF-ANT_130829 HORIZONTAL RBW:1000.000kHz VBW:3000.000kHz SVWT:Auto Detector : Peak Project : 660115 Mode : 110</p>	 <p>Date: 2016-07-06</p> <p>Site : 03CH07-HY Condition : FCC CLASS-B 3m HF-ANT_130829 HORIZONTAL RBW:1000.000kHz VBW:3000.000kHz SVWT:Auto Detector : Peak Project : 660115 Mode : 110</p>
Avg.	 <p>Date: 2016-07-06</p> <p>Site : 03CH07-HY Condition : FCC CLASS-B (AVG) 3m HF-ANT_130829 HORIZONTAL RBW:1000.000kHz VBW:5.000kHz SVWT:Auto Detector : Peak Project : 660115 Mode : 110</p>	Left blank



WIFI	Band 3 5470~5725MHz Band Edge @ 3m	
ANT	802.11ac VHT80 CH122 5610MHz - R	
2	Horizontal	Fundamental
Peak	<p>Date: 2016-07-06</p> <p>Site : 03CH07-HY Condition : FCC CLASS-B 3m HF-ANT_130829 HORIZONTAL RBW:1000.000kHz VBW:3000.000kHz SVWT:Auto Detector : Peak Project : 660115 Mode : 110</p>	Left blank
Avg.	<p>Date: 2016-07-06</p> <p>Site : 03CH07-HY Condition : FCC CLASS-B (AVG) 3m HF-ANT_130829 HORIZONTAL RBW:1000.000kHz VBW:5.000kHz SVWT:Auto Detector : Peak Project : 660115 Mode : 110</p>	Left blank



WIFI	Band 3 5470~5725MHz Band Edge @ 3m	
ANT	802.11ac VHT80 CH122 5610MHz - L	
2	Vertical	Fundamental
Peak	<p>Site : 03CH07-HY Condition : FCC CLASS-B 3m HF-ANT_130829 VERTICAL : RBW:1000.000kHz VBW:3000.000kHz SWT:Auto Detector : Peak Project : 660115 Mode : Y10</p>	<p>Site : 03CH07-HY Condition : FCC CLASS-B 3m HF-ANT_130829 VERTICAL : RBW:1000.000kHz VBW:3000.000kHz SWT:Auto Detector : Peak Project : 660115 Mode : Y10</p>
Avg.	<p>Site : 03CH07-HY Condition : FCC CLASS-B (AVG) 3m HF-ANT_130829 VERTICAL : RBW:1000.000kHz VBW:5.000kHz SWT:Auto Detector : Peak Project : 660115 Mode : Y10</p>	Left blank



WIFI	Band 3 5470~5725MHz Band Edge @ 3m	
ANT	802.11ac VHT80 CH122 5610MHz - R	
2	Vertical	Fundamental
Peak	<p>Site : 03CH07-HY Condition : FCC CLASS-B 3m HF-ANT_130829 VERTICAL RBW:1000.000kHz VBW:3000.000kHz SWT:Auto Detector : Peak Project : 660115 Mode : 110</p>	Left blank
Avg.	<p>Site : 03CH07-HY Condition : FCC CLASS-B (AVG) 3m HF-ANT_130829 VERTICAL RBW:1000.000kHz VBW:5.000kHz SWT:Auto Detector : Peak Project : 660115 Mode : 110</p>	Left blank



Band 3 - 5470~5725MHz
WIFI 802.11a (Harmonic @ 3m)

WIFI	Band 3 5470~5725MHz Harmonic @ 3m	
ANT	802.11a CH100 5500MHz	
2	Horizontal	Vertical
<p>Peak Avg.</p>	<p>Site : 03CH07HY Condition : FCC CLASS-B 3m SHF-EHF_131129 HORIZONTAL Detector : Peak Project : 660115 Mode : 100</p>	<p>Site : 03CH07HY Condition : FCC CLASS-B 3m SHF-EHF_131129 VERTICAL Detector : Peak Project : 660115 Mode : 100</p>



WIFI	Band 3 5470~5725MHz Harmonic @ 3m	
ANT	802.11a CH116 5580MHz	
2	Horizontal	Vertical
Peak Avg.	<p>Site : 03CH07-HY Condition : FCC CLASS-B 3m SHF-EHF_131029 HORIZONTAL Detector : Peak Project : 660115 Mode : 101</p>	<p>Site : 03CH07-HY Condition : FCC CLASS-B 3m SHF-EHF_131029 VERTICAL Detector : Peak Project : 660115 Mode : 101</p>



WIFI	Band 3 5470~5725MHz Harmonic @ 3m	
ANT	802.11a CH140 5700MHz	
2	Horizontal	Vertical
<p>Peak Avg.</p>	<p>Site : 03CH07-HY Condition : FCC CLASS-B 3m SHF-EHF_131029 HORIZONTAL Detector : Peak Project : 660115 Mode : 102</p>	<p>Site : 03CH07-HY Condition : FCC CLASS-B 3m SHF-EHF_131029 VERTICAL Detector : Peak Project : 660115 Mode : 102</p>



**Band 3 5470~5725MHz
WIFI 802.11ac VHT20 (Harmonic @ 3m)**

WIFI	Band 3 5470~5725MHz Harmonic @ 3m	
ANT	802.11ac VHT20 CH100 5500MHz	
2	Horizontal	Vertical
<p>Peak</p> <p>Avg.</p>	<p>Site : 03CM07-HY Condition : FCC CLASS-B 3m SHF-EHF_131029 HORIZONTAL Detector : Peak Project : 660115 Mode : 103</p>	<p>Site : 03CM07-HY Condition : FCC CLASS-B 3m SHF-EHF_131029 VERTICAL Detector : Peak Project : 660115 Mode : 103</p>

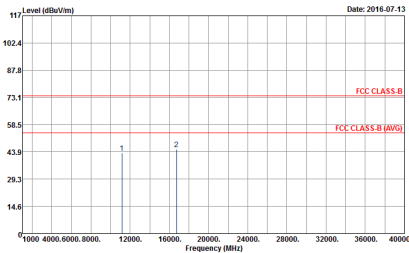
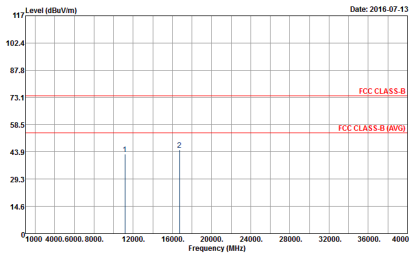

WIFI	Band 3 5470~5725MHz Harmonic @ 3m	
ANT	802.11ac VHT20 CH116 5580MHz	
2	Horizontal	Vertical
Peak Avg.	 <p style="font-size: small;">Date: 2016-07-13</p> <p style="font-size: x-small;">Site : 03CH07-HY Condition : FCC CLASS B 3m SHF-EHF_131029 HORIZONTAL Detector : Peak Project : 660115 Mode : 104</p>	 <p style="font-size: small;">Date: 2016-07-13</p> <p style="font-size: x-small;">Site : 03CH07-HY Condition : FCC CLASS B 3m SHF-EHF_131029 VERTICAL Detector : Peak Project : 660115 Mode : 104</p>

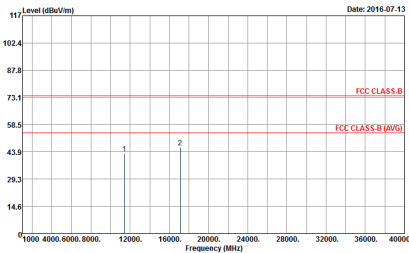
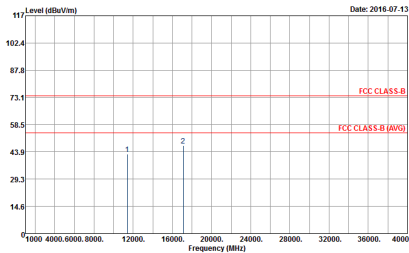

WIFI	Band 3 5470~5725MHz Harmonic @ 3m	
ANT	802.11ac VHT20 CH140 5700MHz	
2	Horizontal	Vertical
Peak Avg.	 <p style="font-size: small;">Date: 2016-07-13</p> <p style="font-size: x-small;">Site : 03CH07-HY Condition : FCC CLASS B 3m SHF-EHF_131029 HORIZONTAL Detector : Peak Project : 660115 Mode : 105</p>	 <p style="font-size: small;">Date: 2016-07-13</p> <p style="font-size: x-small;">Site : 03CH07-HY Condition : FCC CLASS B 3m SHF-EHF_131029 VERTICAL Detector : Peak Project : 660115 Mode : 105</p>



**Band 3 5470~5725MHz
WIFI 802.11ac VHT40 (Harmonic @ 3m)**

WIFI	Band 3 5470~5725MHz Harmonic @ 3m	
ANT	802.11ac VHT40 CH102 5510MHz	
2	Horizontal	Vertical
Peak Avg.	<p>Site : 03CM07-HY Condition : FCC CLASS-B 3m SHF-EHF_131029 HORIZONTAL Detector : Peak Project : 660115 Mode : 106</p>	<p>Site : 03CM07-HY Condition : FCC CLASS-B 3m SHF-EHF_131029 VERTICAL Detector : Peak Project : 660115 Mode : 106</p>



WIFI	Band 3 5470~5725MHz Harmonic @ 3m	
ANT	802.11ac VHT40 CH110 5550MHz	
2	Horizontal	Vertical
Peak Avg.	<p style="font-size: small;">Date: 2016-07-13</p> <p style="font-size: x-small;">Site : 03CH07-HY Condition : FCC CLASS-B 3m SHF-EHF_1311029 HORIZONTAL Detector : Peak Project : 660115 Mode : 107</p>	<p style="font-size: small;">Date: 2016-07-13</p> <p style="font-size: x-small;">Site : 03CH07-HY Condition : FCC CLASS-B 3m SHF-EHF_1311029 VERTICAL Detector : Peak Project : 660115 Mode : 107</p>



WIFI	Band 3 5470~5725MHz Harmonic @ 3m	
ANT	802.11ac VHT40 CH134 5670MHz	
2	Horizontal	Vertical
Peak Avg.	<p style="font-size: small;">Date: 2016-07-13</p> <p style="font-size: x-small;">Site : 03CH07-HY Condition : FCC CLASS-B 3m SHF-EHF_131029 HORIZONTAL Detector : Peak Project : 660115 Mode : 108</p>	<p style="font-size: small;">Date: 2016-07-13</p> <p style="font-size: x-small;">Site : 03CH07-HY Condition : FCC CLASS-B 3m SHF-EHF_131029 VERTICAL Detector : Peak Project : 660115 Mode : 108</p>



Band 3 5470~5725MHz
WIFI 802.11ac VHT80 (Harmonic @ 3m)

WIFI	Band 3 5470~5725MHz Harmonic @ 3m	
ANT	802.11ac VHT80 CH106 5530MHz	
2	Horizontal	Vertical
<p>Peak Avg.</p>	<p>Site : 03CH07-HY Condition : FCC CLASS-B 3m SHF-EHF_131029 HORIZONTAL Detector : Peak Project : 660115 Mode : 109</p>	<p>Site : 03CH07-HY Condition : FCC CLASS-B 3m SHF-EHF_131029 VERTICAL Detector : Peak Project : 660115 Mode : 109</p>



WIFI	Band 3 5470~5725MHz Harmonic @ 3m	
ANT	802.11ac VHT80 CH122 5610MHz	
2	Horizontal	Vertical
Peak Avg.	<p>Site : 03CH07-HY Condition : FCC CLASS-B 3m SHF-EHF_131029 HORIZONTAL Detector : Peak Project : 660115 Mode : 110</p>	<p>Site : 03CH07-HY Condition : FCC CLASS-B 3m SHF-EHF_131029 VERTICAL Detector : Peak Project : 660115 Mode : 110</p>



Band 3 - Straddle Channel
WIFI 802.11a (Fundamental @ 3m)

WIFI	Band 3 Straddle Channel Fundamental @ 3m	
ANT	802.11a CH144 5720MHz	
2	Horizontal	Vertical
Peak Avg.	<p> Site : 03CH07.HY Condition : FCC CLASS-B 3m HF-ANT, 130029 HORIZONTAL Detector : Peak Project : 660115 Mode : 111 </p>	<p> Site : 03CH07.HY Condition : FCC CLASS-B 3m HF-ANT, 130029 VERTICAL Detector : Peak Project : 660115 Mode : 111 </p>

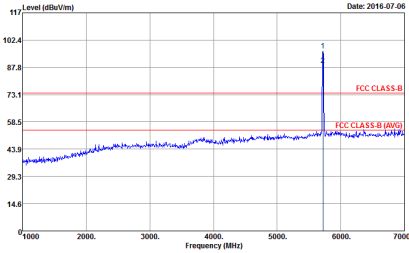
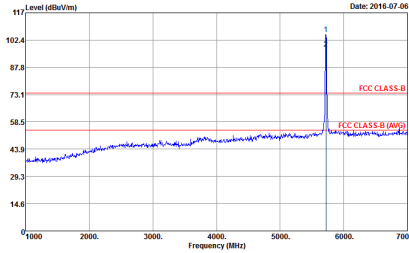

**Band 3 – Straddle Channel
WIFI 802.11ac VHT20 (Fundamental @ 3m)**

WIFI	Band 3 Straddle Channel Fundamental @ 3m	
ANT	802.11ac VHT20 CH144 5720MHz	
2	Horizontal	Vertical
<p>Peak Avg.</p>	 <p>Date: 2016-07-06</p> <p>Site : 03CH07-HY Condition : FCC CLASS-B 3m HF-ANT_130829 HORIZONTAL : RBW:1000.000kHz VBW:3000.000kHz SWT:Auto Detector : Peak Project : 660115 Mode : 112</p>	 <p>Date: 2016-07-06</p> <p>Site : 03CH07-HY Condition : FCC CLASS-B 3m HF-ANT_130829 VERTICAL : RBW:1000.000kHz VBW:3000.000kHz SWT:Auto Detector : Peak Project : 660115 Mode : 112</p>



Band 3 – Straddle Channel
WIFI 802.11ac VHT40 (Fundamental @ 3m)

Table with 2 columns: Horizontal and Vertical. It contains two spectral plots showing Level (dBuV/m) vs Frequency (MHz) for Peak and Avg. measurements. Includes technical details like Site, Condition, Detector, Project, and Mode.



Band 3 – Straddle Channel
WIFI 802.11ac VHT80 (Fundamental @ 3m)

Table with 2 columns: Horizontal and Vertical. Each column contains a spectral plot of Level (dBuV/m) vs Frequency (MHz) with FCC CLASS-B and FCC CLASS-B (AVG) limits. Includes metadata for Site, Condition, Detector, Project, and Mode.



Band 3 - Straddle Channel
WIFI 802.11a (Harmonic @ 3m)

WIFI	Band 3 Straddle Channel Harmonic @ 3m	
ANT	802.11a CH144 5720MHz	
2	Horizontal	Vertical
Peak Avg.	<p> <small>Date: 2016-07-13</small> <small>Site : 03CH07HY</small> <small>Condition : FCC CLASS-B 3m SHF-EHF_131029 HORIZONTAL</small> <small>Detector : Peak</small> <small>Project : 660115</small> <small>Mode : 111</small> </p>	<p> <small>Date: 2016-07-13</small> <small>Site : 03CH07HY</small> <small>Condition : FCC CLASS-B 3m SHF-EHF_131029 VERTICAL</small> <small>Detector : Peak</small> <small>Project : 660115</small> <small>Mode : 111</small> </p>

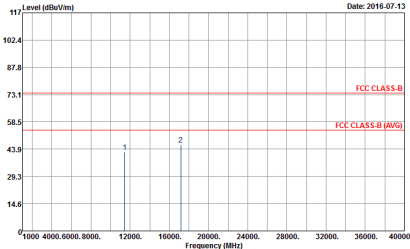
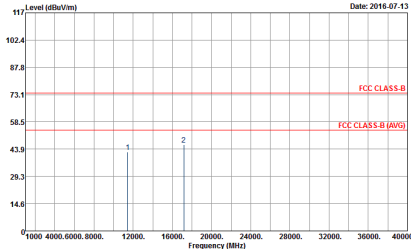

**Band 3 – Straddle Channel
WIFI 802.11ac VHT20 (Harmonic @ 3m)**

WIFI	Band 3 Straddle Channel Harmonic @ 3m	
ANT	802.11ac VHT20 CH144 5720MHz	
2	Horizontal	Vertical
<p>Peak Avg.</p>	 <p>Date: 2016-07-13</p> <p>Site : 03CH07-HY Condition : FCC CLASS-B 3m SHF-EHF_131029 HORIZONTAL Detector : Peak Project : 660115 Mode : 112</p>	 <p>Date: 2016-07-13</p> <p>Site : 03CH07-HY Condition : FCC CLASS-B 3m SHF-EHF_131029 VERTICAL Detector : Peak Project : 660115 Mode : 112</p>



**Band 3 – Straddle Channel
WIFI 802.11ac VHT40 (Harmonic @ 3m)**

WIFI	Band 3 Straddle Channel Harmonic @ 3m	
ANT	802.11ac VHT40 CH142 5710MHz	
2	Horizontal	Vertical
Peak Avg.	<p> Site : 03CH07-HY Condition : FCC CLASS-B 3m SHF-EHF_1311029 HORIZONTAL Detector : Peak Project : 660115 Mode : 113 </p>	<p> Site : 03CH07-HY Condition : FCC CLASS-B 3m SHF-EHF_1311029 VERTICAL Detector : Peak Project : 660115 Mode : 113 </p>



**Band 3 – Straddle Channel
WIFI 802.11ac VHT80 (Harmonic @ 3m)**

WIFI	Band 3 Straddle Channel Harmonic @ 3m	
ANT	802.11ac VHT80 CH138 5690MHz	
2	Horizontal	Vertical
Peak Avg.	<p>Site : 03CH07-HY Condition : FCC CLASS-B 3m SHF-EHF_131029 HORIZONTAL Detector : Peak Project : 660115 Mode : 114</p>	<p>Site : 03CH07-HY Condition : FCC CLASS-B 3m SHF-EHF_131029 VERTICAL Detector : Peak Project : 660115 Mode : 114</p>



Emission below 1GHz
5GHz WIFI 802.11a (LF)

WIFI	5GHz WIFI	
ANT	802.11a LF	
2	Horizontal	Vertical
QP / Peak	<p>Site : 03CH07-HY Condition : 15.209 3m LF-ANT-35419(6) HORIZONTAL Detector : Peak Project : 660115 Mode : 115</p>	<p>Site : 03CH07-HY Condition : 15.209 3m LF-ANT-35419(6) VERTICAL Detector : Peak Project : 660115 Mode : 115</p>



Emission below 1GHz
5GHz WIFI 802.11ac VHT20 (LF)

WIFI	5GHz WIFI	
ANT	802.11ac VHT20 LF	
2	Horizontal	Vertical
QP / Peak	<p> Date: 2016-07-16 Site : 03CH07-HY Condition : 15.209 3m LF-ANT-35419(6) HORIZONTAL Detector : Peak Project : 660115 Mode : 116 </p>	<p> Date: 2016-07-16 Site : 03CH07-HY Condition : 15.209 3m LF-ANT-35419(6) VERTICAL Detector : Peak Project : 660115 Mode : 116 </p>



Emission below 1GHz
5GHz WIFI 802.11ac VHT40 (LF)

WIFI	5GHz WIFI	
ANT	802.11ac VHT40 LF	
2	Horizontal	Vertical
QP / Peak	<p> Date: 2016-07-16 Site : 03CH07-HY Condition : 15.209 3m LF-ANT-35419(6) HORIZONTAL Detector : Peak Project : 660115 Mode : 117 </p>	<p> Date: 2016-07-16 Site : 03CH07-HY Condition : 15.209 3m LF-ANT-35419(6) VERTICAL Detector : Peak Project : 660115 Mode : 117 </p>



Emission below 1GHz
5GHz WIFI 802.11ac VHT80 (LF)

Table with 2 columns: Horizontal and Vertical. It contains two spectral plots showing Level (dBuV/m) vs Frequency (MHz) for 5GHz WIFI 802.11ac VHT80 LF. The plots show a peak at 15.209 MHz. The table also includes a 'WIFI' header and an 'ANT' header.



<CDD Mode>

Band 1 - 5150~5250MHz

WIFI 802.11a (Band Edge @ 3m)

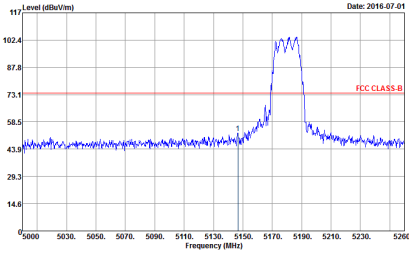
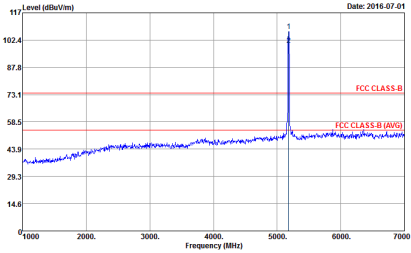
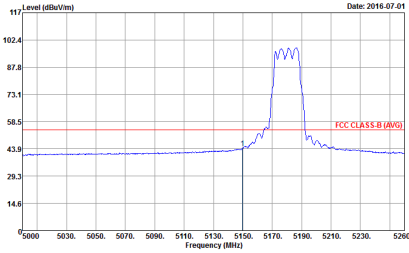
WIFI	Band 1 5150~5250MHz Band Edge @ 3m	
ANT	802.11a CH36 5180MHz	
1+2	Horizontal	Fundamental
Peak	 <p>Date: 2016-07-01</p> <p>Site : 03CH07-HY Condition : FCC CLASS-B 3m HF-ANT_130829 HORIZONTAL RBW: 1000.000kHz VBW: 3000.000kHz SWT: Auto Detector : Peak Project : 660115 Mode : 1</p>	 <p>Date: 2016-07-01</p> <p>Site : 03CH07-HY Condition : FCC CLASS-B 3m HF-ANT_130829 HORIZONTAL RBW: 1000.000kHz VBW: 3000.000kHz SWT: Auto Detector : Peak Project : 660115 Mode : 1</p>
Avg.	 <p>Date: 2016-07-01</p> <p>Site : 03CH07-HY Condition : FCC CLASS-B (AVG) 3m HF-ANT_130829 HORIZONTAL RBW: 1000.000kHz VBW: 1.000kHz SWT: Auto Detector : Peak Project : 660115 Mode : 1</p>	Left blank



WIFI	Band 1 5150~5250MHz Band Edge @ 3m	
ANT	802.11a CH36 5180MHz	
1+2	Vertical	Fundamental
Peak	<p>Site : 03CH07-HY Condition : FCC CLASS-B 3m HF-ANT_130829 VERTICAL RBW:1000.000kHz VBW:3000.000kHz SVWT:Auto Detector : Peak Project : 660115 Mode : 1</p>	<p>Site : 03CH07-HY Condition : FCC CLASS-B 3m HF-ANT_130829 VERTICAL RBW:1000.000kHz VBW:3000.000kHz SVWT:Auto Detector : Peak Project : 660115 Mode : 1</p>
Avg.	<p>Site : 03CH07-HY Condition : FCC CLASS-B (AVG) 3m HF-ANT_130829 VERTICAL RBW:1000.000kHz VBW:1.000kHz SVWT:Auto Detector : Peak Project : 660115 Mode : 1</p>	Left blank



WIFI	Band 1 5150~5250MHz Band Edge @ 3m	
ANT	802.11a CH44 5220MHz - L	
1+2	Horizontal	Fundamental
Peak	<p>Site : 03CH07-HY Condition : FCC CLASS-B 3m HF-ANT_130829 HORIZONTAL RBW:1000.000kHz VBW:3000.000kHz SVWT:Auto Detector : Peak Project : 660115 Mode : 2</p>	<p>Site : 03CH07-HY Condition : FCC CLASS-B 3m HF-ANT_130829 HORIZONTAL RBW:1000.000kHz VBW:3000.000kHz SVWT:Auto Detector : Peak Project : 660115 Mode : 2</p>
Avg.	<p>Site : 03CH07-HY Condition : FCC CLASS-B (AVG) 3m HF-ANT_130829 HORIZONTAL RBW:1000.000kHz VBW:1.000kHz SVWT:Auto Detector : Peak Project : 660115 Mode : 2</p>	Left blank

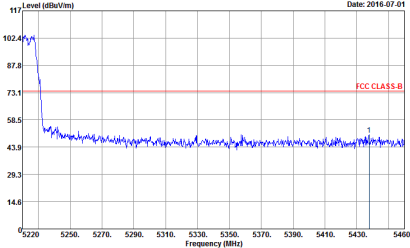
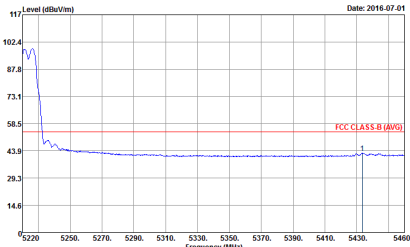

WIFI	Band 1 5150~5250MHz Band Edge @ 3m	
ANT	802.11a CH44 5220MHz - R	
1+2	Horizontal	Fundamental
Peak	 <p>Site : 03CH07-HY Condition : FCC CLASS-B 3m HF-ANT_130829 HORIZONTAL RBW:1000.000kHz VBW:3000.000kHz SVWT:Auto Detector : Peak Project : 660115 Mode : 2</p>	Left blank
Avg.	 <p>Site : 03CH07-HY Condition : FCC CLASS-B (AVG) 3m HF-ANT_130829 HORIZONTAL RBW:1000.000kHz VBW:1.000kHz SVWT:Auto Detector : Peak Project : 660115 Mode : 2</p>	Left blank



WIFI	Band 1 5150~5250MHz Band Edge @ 3m	
ANT	802.11a CH44 5220MHz - L	
1+2	Vertical	Fundamental
Peak	<p>Site : 03CH07-HY Condition : FCC CLASS-B 3m HF-ANT_130829 VERTICAL RBW:1000.000kHz VBW:3000.000kHz SVT:Auto Detector : Peak Project : 660115 Mode : 2</p>	<p>Site : 03CH07-HY Condition : FCC CLASS-B 3m HF-ANT_130829 VERTICAL RBW:1000.000kHz VBW:3000.000kHz SVT:Auto Detector : Peak Project : 660115 Mode : 2</p>
Avg.	<p>Site : 03CH07-HY Condition : FCC CLASS-B (AVG) 3m HF-ANT_130829 VERTICAL RBW:1000.000kHz VBW:1.000kHz SVT:Auto Detector : Peak Project : 660115 Mode : 2</p>	Left blank

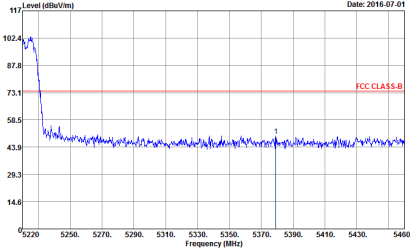
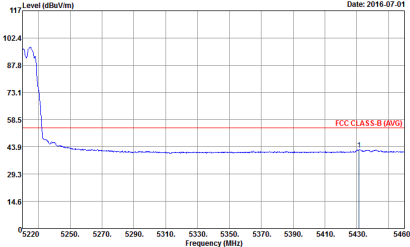

WIFI	Band 1 5150~5250MHz Band Edge @ 3m	
ANT	802.11a CH44 5220MHz - R	
1+2	Vertical	Fundamental
Peak	 <p>Date: 2016.07.01</p> <p>Site : 03CH07-HY Condition : FCC CLASS-B 3m HF-ANT_130829 VERTICAL RBW:1000.000kHz VBW:3000.000kHz SVWT:Auto Detector : Peak Project : 660115 Mode : 2</p>	Left blank
Avg.	 <p>Date: 2016.07.01</p> <p>Site : 03CH07-HY Condition : FCC CLASS-B (AVG) 3m HF-ANT_130829 VERTICAL RBW:1000.000kHz VBW:1.000kHz SVWT:Auto Detector : Peak Project : 660115 Mode : 2</p>	Left blank



WIFI	Band 1 5150~5250MHz Band Edge @ 3m	
ANT	802.11a CH48 5240MHz - L	
1+2	Horizontal	Fundamental
Peak	<p>Site : 03CH07-HY Condition : FCC CLASS-B 3m HF-ANT_130829 HORIZONTAL RBW:1000.000kHz VBW:3000.000kHz SVWT:Auto Detector : Peak Project : 660115 Mode : 3</p>	<p>Site : 03CH07-HY Condition : FCC CLASS-B 3m HF-ANT_130829 HORIZONTAL RBW:1000.000kHz VBW:3000.000kHz SVWT:Auto Detector : Peak Project : 660115 Mode : 3</p>
Avg.	<p>Site : 03CH07-HY Condition : FCC CLASS-B (AVG) 3m HF-ANT_130829 HORIZONTAL RBW:1000.000kHz VBW:1.000kHz SVWT:Auto Detector : Peak Project : 660115 Mode : 3</p>	Left blank

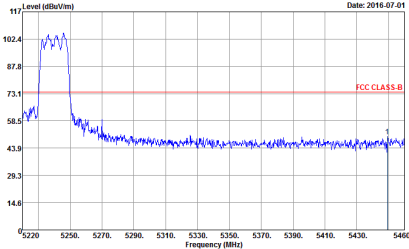
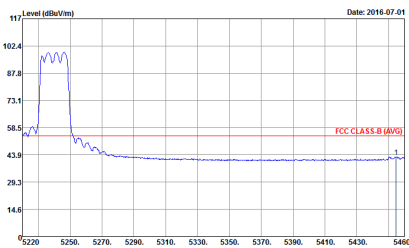

WIFI	Band 1 5150~5250MHz Band Edge @ 3m	
ANT	802.11a CH48 5240MHz - R	
1+2	Horizontal	Fundamental
<p>Peak</p>	 <p>Site : 03CH07-HY Condition : FCC CLASS-B 3m HF-ANT_130829 HORIZONTAL RBW:1000.000kHz VBW:3000.000kHz SVWT:Auto Detector : Peak Project : 660115 Mode : 3</p>	<p>Left blank</p>
<p>Avg.</p>	 <p>Site : 03CH07-HY Condition : FCC CLASS-B (AVG) 3m HF-ANT_130829 HORIZONTAL RBW:1000.000kHz VBW:1.000kHz SVWT:Auto Detector : Peak Project : 660115 Mode : 3</p>	<p>Left blank</p>



WIFI	Band 1 5150~5250MHz Band Edge @ 3m	
ANT	802.11a CH48 5240MHz - L	
1+2	Vertical	Fundamental
Peak	<p>Date: 2016-07-01</p> <p>Site : 03CH07-HY Condition : FCC CLASS-B 3m HF-ANT_130829 VERTICAL RBW:1000.000kHz VBW:3000.000kHz SVWT:Auto Detector : Peak Project : 660115 Mode : 3</p>	<p>Date: 2016-07-01</p> <p>Site : 03CH07-HY Condition : FCC CLASS-B 3m HF-ANT_130829 VERTICAL RBW:1000.000kHz VBW:3000.000kHz SVWT:Auto Detector : Peak Project : 660115 Mode : 3</p>
Avg.	<p>Date: 2016-07-01</p> <p>Site : 03CH07-HY Condition : FCC CLASS-B (AVG) 3m HF-ANT_130829 VERTICAL RBW:1000.000kHz VBW:1.000kHz SVWT:Auto Detector : Peak Project : 660115 Mode : 3</p>	Left blank



WIFI	Band 1 5150~5250MHz Band Edge @ 3m	
ANT	802.11a CH48 5240MHz - R	
1+2	Vertical	Fundamental
Peak	<p>Date: 2016.07.01</p> <p>Site : 03CH07-HY Condition : FCC CLASS-B 3m HF-ANT_130829 VERTICAL : RBW:1000.000kHz VBW:3000.000kHz SVWT:Auto Detector : Peak Project : 660115 Mode : 3</p>	Left blank
Avg.	<p>Date: 2016.07.01</p> <p>Site : 03CH07-HY Condition : FCC CLASS-B (AVG) 3m HF-ANT_130829 VERTICAL : RBW:1000.000kHz VBW:1.000kHz SVWT:Auto Detector : Peak Project : 660115 Mode : 3</p>	Left blank

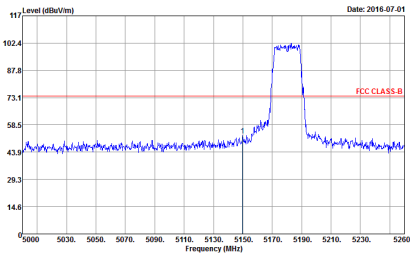
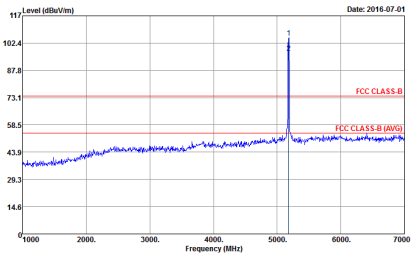
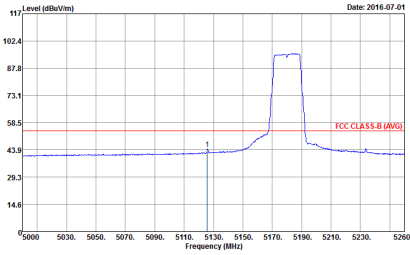

Band 1 5150~5250MHz
WIFI 802.11ac VHT20 (Band Edge @ 3m)

WIFI	Band 1 5150~5250MHz Band Edge @ 3m	
ANT	802.11ac VHT20 CH36 5180MHz	
1+2	Horizontal	Fundamental
Peak	 <p>Date: 2016-07-01</p> <p>Site : 03CH07-HY Condition : FCC CLASS-B 3m HF-ANT_130829 HORIZONTAL RBW: 1000.000kHz VBW: 3000.000kHz SWT: Auto Detector : Peak Project : 660115 Mode : 4</p>	 <p>Date: 2016-07-01</p> <p>Site : 03CH07-HY Condition : FCC CLASS-B 3m HF-ANT_130829 HORIZONTAL RBW: 1000.000kHz VBW: 3000.000kHz SWT: Auto Detector : Peak Project : 660115 Mode : 4</p>
Avg.	 <p>Date: 2016-07-01</p> <p>Site : 03CH07-HY Condition : FCC CLASS-B (AVG) 3m HF-ANT_130829 HORIZONTAL RBW: 1000.000kHz VBW: 1.000kHz SWT: Auto Detector : Peak Project : 660115 Mode : 4</p>	Left blank



WIFI	Band 1 5150~5250MHz Band Edge @ 3m	
ANT	802.11ac VHT20 CH36 5180MHz	
1+2	Vertical	Fundamental
Peak	<p>Date: 2016-07-01</p> <p>Site : 03CH07-HY Condition : FCC CLASS-B 3m HF-ANT_130829 VERTICAL RBW:1000.000kHz VBW:3000.000kHz SVT:Auto Detector : Peak Project : 660115 Mode : 4</p>	<p>Date: 2016-07-01</p> <p>Site : 03CH07-HY Condition : FCC CLASS-B 3m HF-ANT_130829 VERTICAL RBW:1000.000kHz VBW:3000.000kHz SVT:Auto Detector : Peak Project : 660115 Mode : 4</p>
Avg.	<p>Date: 2016-07-01</p> <p>Site : 03CH07-HY Condition : FCC CLASS-B (AVG) 3m HF-ANT_130829 VERTICAL RBW:1000.000kHz VBW:1.000kHz SVT:Auto Detector : Peak Project : 660115 Mode : 4</p>	Left blank