

#01_GSM850_GPRS (2 Tx slots)_Bottom Face_14mm_Ch189

Communication System: GSM850 ; Frequency: 836.4 MHz; Duty Cycle: 1:4.15

Medium: MSL_850_160621 Medium parameters used: $f = 836.4$ MHz; $\sigma = 1.004$ S/m; $\epsilon_r = 57.83$; $\rho = 1000$ kg/m³

Ambient Temperature : 23.5°C; Liquid Temperature : 22.5°C

DASY5 Configuration

- Probe: ES3DV3 - SN3270; ConvF(6.24, 6.24, 6.24); Calibrated: 2015/9/28;
- Sensor-Surface: 3mm (Mechanical Surface Detection)
- Electronics: DAE4 Sn1399; Calibrated: 2015/11/23
- Phantom: ELI v4.0; Type: QDOVA001BB; Serial: 1026
- Measurement SW: DASY52, Version 52.8 (7); SEMCAD X Version 14.6.10 (7164)

Area Scan (61x81x1): Interpolated grid: dx=1.500 mm, dy=1.500 mm

Maximum value of SAR (interpolated) = 0.882 W/kg

Zoom Scan (5x5x7)/Cube 0: Measurement grid: dx=8mm, dy=8mm, dz=5mm

Reference Value = 26.882 V/m; Power Drift = -0.19 dB

Peak SAR (extrapolated) = 1.18 W/kg

SAR(1 g) = 0.774 W/kg; SAR(10 g) = 0.487 W/kg

Maximum value of SAR (measured) = 0.919 W/kg

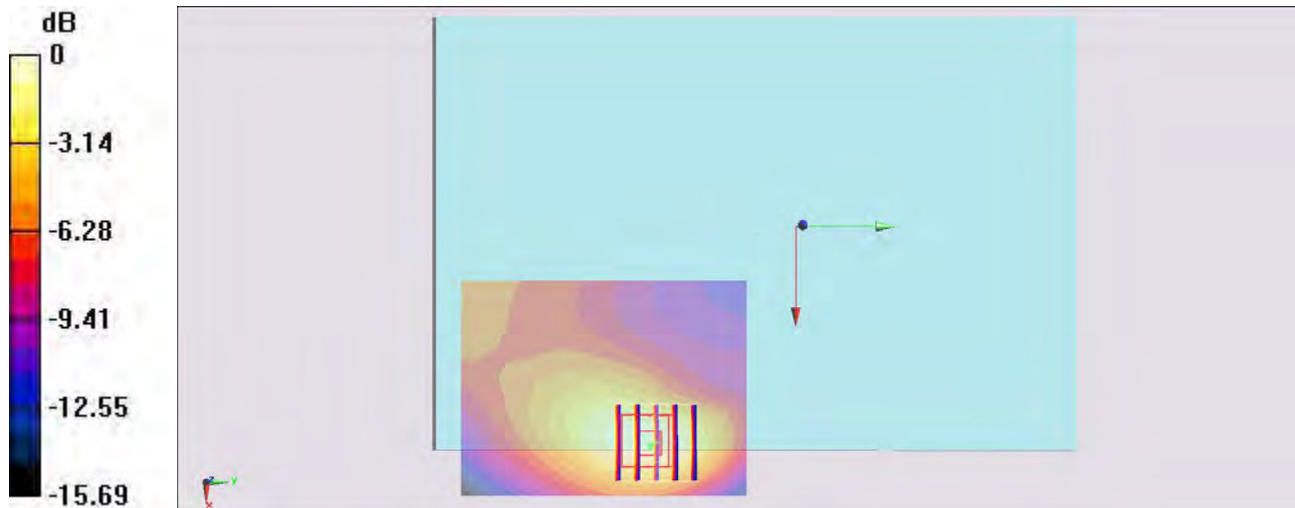

0 dB = 0.882 W/kg = -0.55 dBW/kg

#02_GSM1900_EDGE (4 Tx slots)_Edge 1_0mm_Ch512

Communication System: PCS; Frequency: 1850.2 MHz; Duty Cycle: 1:2.08

Medium: MSL_1900_160624 Medium parameters used: $f = 1850.2$ MHz; $\sigma = 1.47$ S/m; $\epsilon_r = 53.956$; $\rho = 1000$ kg/m³

Ambient Temperature : 23.8 °C; Liquid Temperature : 22.8 °C

DASY5 Configuration

- Probe: ES3DV3 - SN3270; ConvF(4.78, 4.78, 4.78); Calibrated: 2015/9/28;
- Sensor-Surface: 3mm (Mechanical Surface Detection)
- Electronics: DAE4 Sn1399; Calibrated: 2015/11/23
- Phantom: ELI v4.0; Type: QDOVA001BB; Serial: 1026
- Measurement SW: DASY52, Version 52.8 (7); SEMCAD X Version 14.6.10 (7164)

Area Scan (51x81x1): Interpolated grid: dx=1.500 mm, dy=1.500 mm

Maximum value of SAR (interpolated) = 0.608 W/kg

Zoom Scan (5x5x7)/Cube 0: Measurement grid: dx=8mm, dy=8mm, dz=5mm

Reference Value = 19.701 V/m; Power Drift = 0.17 dB

Peak SAR (extrapolated) = 0.971 W/kg

SAR(1 g) = 0.477 W/kg; SAR(10 g) = 0.207 W/kg

Maximum value of SAR (measured) = 0.595 W/kg

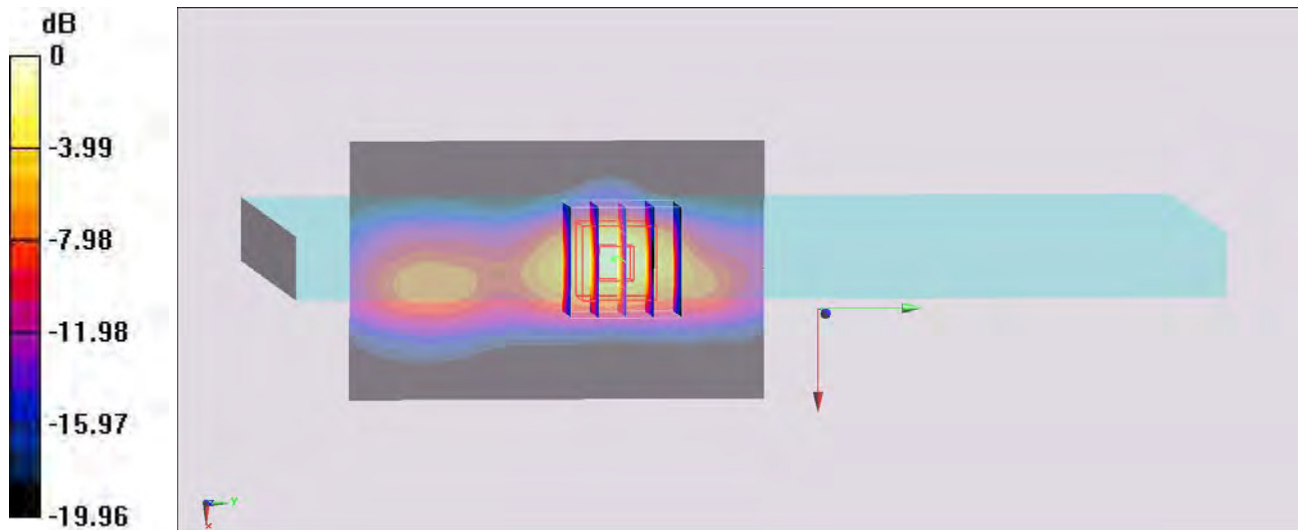

0 dB = 0.608 W/kg = -2.16 dBW/kg

#03_WCDMA II_RMC 12.2Kbps_Edge 1_0mm_Ch9538

Communication System: WCDMA; Frequency: 1907.6 MHz; Duty Cycle: 1:1

Medium: MSL_1900_160624 Medium parameters used: $f = 1908 \text{ MHz}$; $\sigma = 1.536 \text{ S/m}$; $\epsilon_r = 53.829$; $\rho = 1000 \text{ kg/m}^3$

Ambient Temperature : $23.8 \text{ }^\circ\text{C}$; Liquid Temperature : $22.8 \text{ }^\circ\text{C}$

DASY5 Configuration

- Probe: ES3DV3 - SN3270; ConvF(4.78, 4.78, 4.78); Calibrated: 2015/9/28;
- Sensor-Surface: 3mm (Mechanical Surface Detection)
- Electronics: DAE4 Sn1399; Calibrated: 2015/11/23
- Phantom: ELI v4.0; Type: QDOVA001BB; Serial: 1026
- Measurement SW: DASY52, Version 52.8 (7); SEMCAD X Version 14.6.10 (7164)

Area Scan (41x81x1): Interpolated grid: $dx=1.500 \text{ mm}$, $dy=1.500 \text{ mm}$

Maximum value of SAR (interpolated) = 1.03 W/kg

Zoom Scan (5x5x7)/Cube 0: Measurement grid: $dx=8\text{mm}$, $dy=8\text{mm}$, $dz=5\text{mm}$

Reference Value = 24.963 V/m ; Power Drift = 0.05 dB

Peak SAR (extrapolated) = 1.62 W/kg

SAR(1 g) = 0.788 W/kg ; SAR(10 g) = 0.343 W/kg

Maximum value of SAR (measured) = 1.05 W/kg

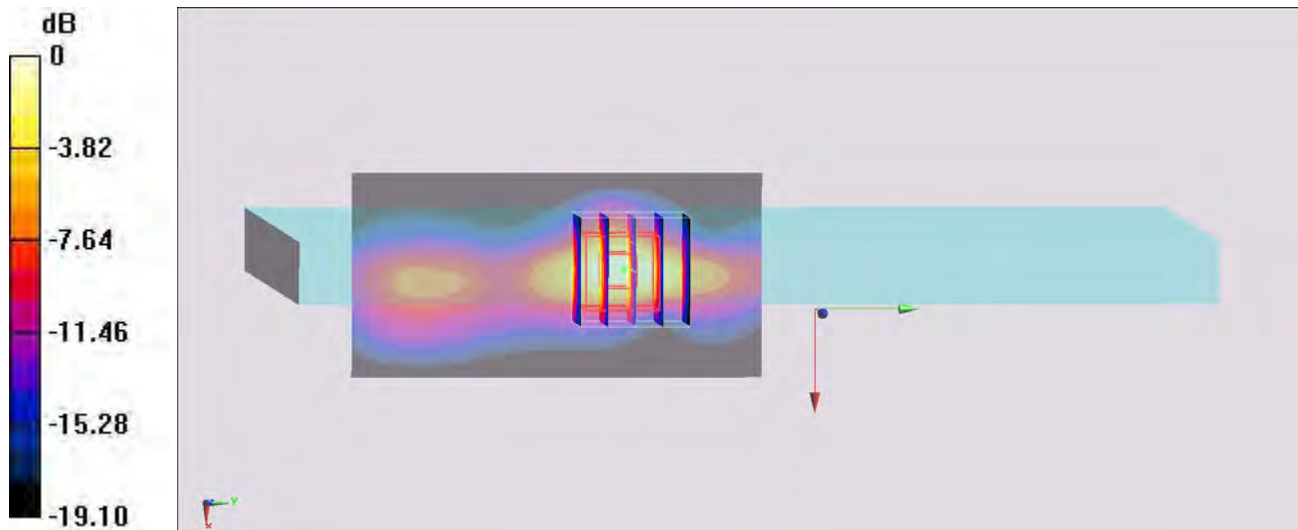

0 dB = 1.03 W/kg = 0.13 dBW/kg

#04_WCDMA IV_RMC 12.2Kbps_Edge 1_0mm_Ch1413

Communication System: WCDMA; Frequency: 1732.6 MHz; Duty Cycle: 1:1

Medium: MSL_1750_160625 Medium parameters used: $f = 1733 \text{ MHz}$; $\sigma = 1.519 \text{ S/m}$; $\epsilon_r = 55.647$; $\rho = 1000 \text{ kg/m}^3$

Ambient Temperature : 23.8°C ; Liquid Temperature : 22.8°C

DASY5 Configuration

- Probe: ES3DV3 - SN3270; ConvF(4.95, 4.95, 4.95); Calibrated: 2015/9/28;
- Sensor-Surface: 3mm (Mechanical Surface Detection)
- Electronics: DAE4 Sn1399; Calibrated: 2015/11/23
- Phantom: ELI v4.0; Type: QDOVA001BB; Serial: 1026
- Measurement SW: DASY52, Version 52.8 (7); SEMCAD X Version 14.6.10 (7164)

Area Scan (41x81x1): Interpolated grid: $dx=1.500 \text{ mm}$, $dy=1.500 \text{ mm}$

Maximum value of SAR (interpolated) = 0.533 W/kg

Zoom Scan (5x5x7)/Cube 0: Measurement grid: $dx=8\text{mm}$, $dy=8\text{mm}$, $dz=5\text{mm}$

Reference Value = 19.661 V/m ; Power Drift = 0.14 dB

Peak SAR (extrapolated) = 0.876 W/kg

SAR(1 g) = 0.449 W/kg ; SAR(10 g) = 0.204 W/kg

Maximum value of SAR (measured) = 0.609 W/kg

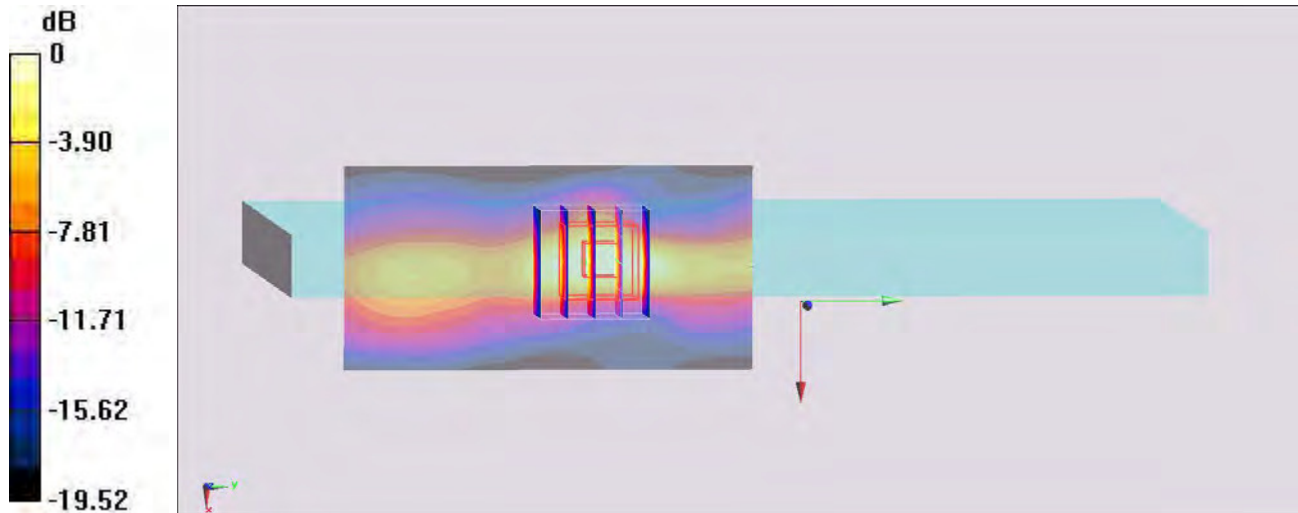

0 dB = $0.533 \text{ W/kg} = -2.73 \text{ dBW/kg}$

#05_WCDMA V_RMC 12.2Kbps_Bottom Face_14mm_Ch4233

Communication System: WCDMA ; Frequency: 846.6 MHz; Duty Cycle: 1:1

Medium: MSL_850_160621 Medium parameters used: $f = 847 \text{ MHz}$; $\sigma = 1.014 \text{ S/m}$; $\epsilon_r = 57.734$; $\rho = 1000 \text{ kg/m}^3$

Ambient Temperature : 23.5°C ; Liquid Temperature : 22.5°C

DASY5 Configuration

- Probe: ES3DV3 - SN3270; ConvF(6.24, 6.24, 6.24); Calibrated: 2015/9/28;
- Sensor-Surface: 3mm (Mechanical Surface Detection)
- Electronics: DAE4 Sn1399; Calibrated: 2015/11/23
- Phantom: ELI v4.0; Type: QDOVA001BB; Serial: 1026
- Measurement SW: DASY52, Version 52.8 (7); SEMCAD X Version 14.6.10 (7164)

Area Scan (61x81x1): Interpolated grid: $dx=1.500 \text{ mm}$, $dy=1.500 \text{ mm}$

Maximum value of SAR (interpolated) = 0.531 W/kg

Zoom Scan (5x5x7)/Cube 0: Measurement grid: $dx=8\text{mm}$, $dy=8\text{mm}$, $dz=5\text{mm}$

Reference Value = 22.967 V/m ; Power Drift = -0.07 dB

Peak SAR (extrapolated) = 0.675 W/kg

SAR(1 g) = 0.447 W/kg ; SAR(10 g) = 0.285 W/kg

Maximum value of SAR (measured) = 0.528 W/kg

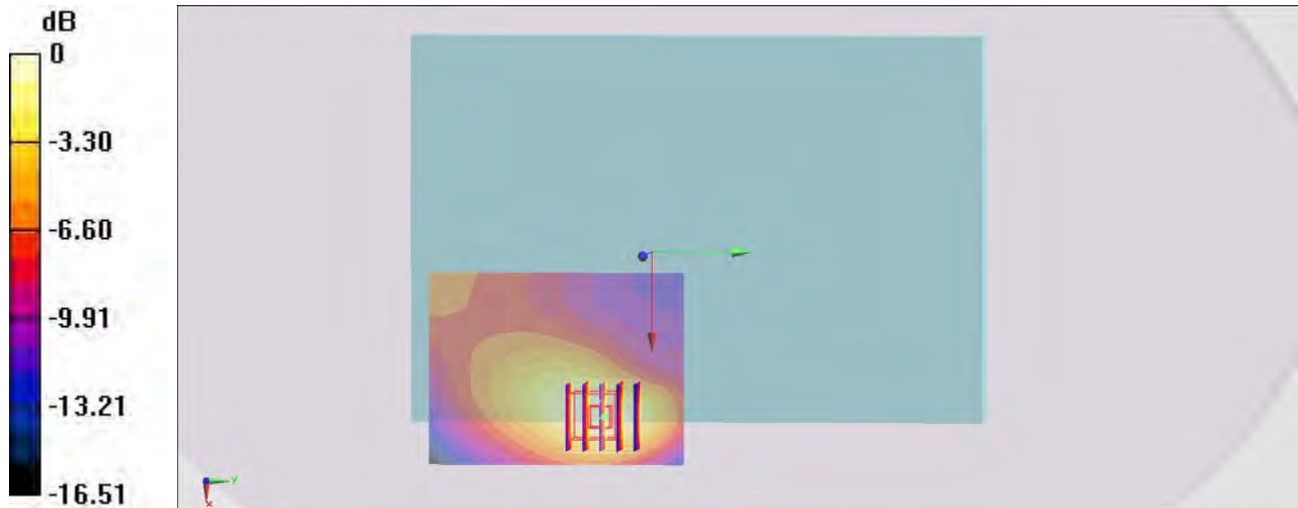

0 dB = 0.531 W/kg = -2.75 dBW/kg

#06_CDMA BC0_RTAP 153.6Kbps_Bottom Face_14mm_Ch777

Communication System: CDMA ; Frequency: 848.31 MHz; Duty Cycle: 1:1

Medium: MSL_850_160621 Medium parameters used: $f = 848.31$ MHz; $\sigma = 1.016$ S/m; $\epsilon_r = 57.72$; $\rho = 1000$ kg/m³

Ambient Temperature : 23.5°C; Liquid Temperature : 22.5°C

DASY5 Configuration

- Probe: ES3DV3 - SN3270; ConvF(6.24, 6.24, 6.24); Calibrated: 2015/9/28;
- Sensor-Surface: 3mm (Mechanical Surface Detection)
- Electronics: DAE4 Sn1399; Calibrated: 2015/11/23
- Phantom: ELI v4.0; Type: QDOVA001BB; Serial: 1026
- Measurement SW: DASY52, Version 52.8 (7); SEMCAD X Version 14.6.10 (7164)

Area Scan (61x81x1): Interpolated grid: dx=1.500 mm, dy=1.500 mm

Maximum value of SAR (interpolated) = 0.590 W/kg

Zoom Scan (5x5x7)/Cube 0: Measurement grid: dx=8mm, dy=8mm, dz=5mm

Reference Value = 24.009 V/m; Power Drift = -0.13 dB

Peak SAR (extrapolated) = 0.749 W/kg

SAR(1 g) = 0.500 W/kg; SAR(10 g) = 0.321 W/kg

Maximum value of SAR (measured) = 0.590 W/kg

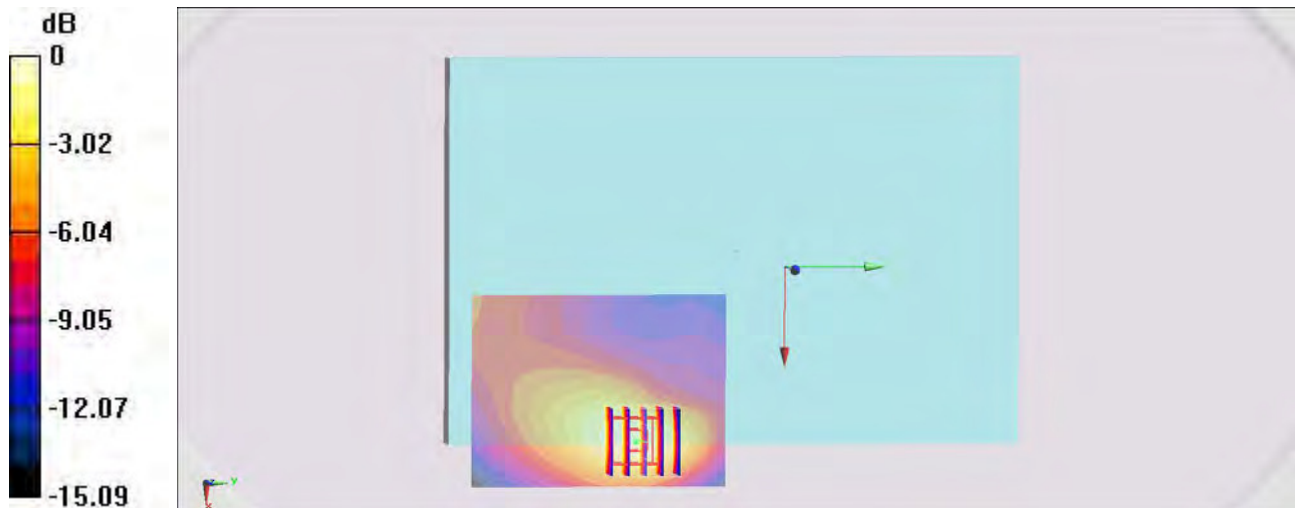

0 dB = 0.590 W/kg = -2.29 dBW/kg

#07_CDMA BC1_RTAP 153.6Kbps_Edge 1_0mm_Ch1175

Communication System: CDMA ; Frequency: 1908.75 MHz; Duty Cycle: 1:1

Medium: MSL_1900_160624 Medium parameters used: $f = 1909$ MHz; $\sigma = 1.537$ S/m; $\epsilon_r = 53.827$; $\rho = 1000$ kg/m³

Ambient Temperature : 23.8°C; Liquid Temperature : 22.8°C

DASY5 Configuration

- Probe: ES3DV3 - SN3270; ConvF(4.78, 4.78, 4.78); Calibrated: 2015/9/28;
- Sensor-Surface: 3mm (Mechanical Surface Detection)
- Electronics: DAE4 Sn1399; Calibrated: 2015/11/23
- Phantom: ELI v4.0; Type: QDOVA001BB; Serial: 1026
- Measurement SW: DASY52, Version 52.8 (7); SEMCAD X Version 14.6.10 (7164)

Area Scan (51x81x1): Interpolated grid: dx=1.500 mm, dy=1.500 mm

Maximum value of SAR (interpolated) = 0.854 W/kg

Zoom Scan (5x5x7)/Cube 0: Measurement grid: dx=8mm, dy=8mm, dz=5mm

Reference Value = 14.179 V/m; Power Drift = -0.14 dB

Peak SAR (extrapolated) = 1.23 W/kg

SAR(1 g) = 0.611 W/kg; SAR(10 g) = 0.271 W/kg

Maximum value of SAR (measured) = 0.783 W/kg

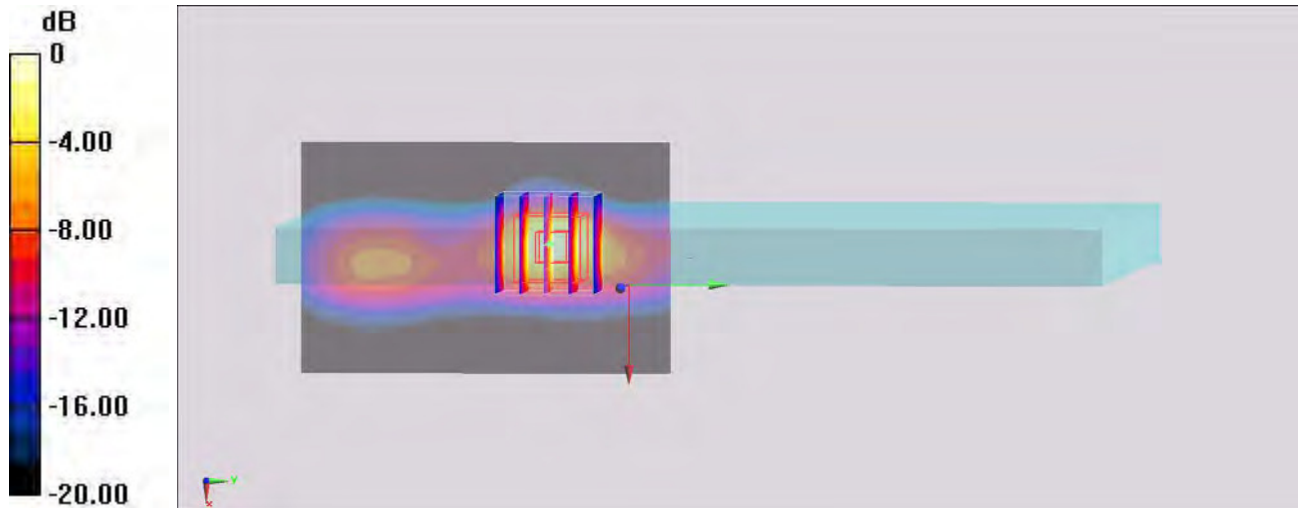

0 dB = 0.854 W/kg = -0.69 dBW/kg

#08_CDMA BC10_RTAP 153.6Kbps_Bottom Face_14mm_Ch580

Communication System: CDMA ; Frequency: 820.5 MHz; Duty Cycle: 1:1

Medium: MSL_850_160621 Medium parameters used: $f = 820.5$ MHz; $\sigma = 0.988$ S/m; $\epsilon_r = 57.969$; $\rho = 1000$ kg/m³

Ambient Temperature : 23.5°C; Liquid Temperature : 22.5°C

DASY5 Configuration

- Probe: ES3DV3 - SN3270; ConvF(6.24, 6.24, 6.24); Calibrated: 2015/9/28;
- Sensor-Surface: 3mm (Mechanical Surface Detection)
- Electronics: DAE4 Sn1399; Calibrated: 2015/11/23
- Phantom: ELI v4.0; Type: QDOVA001BB; Serial: 1026
- Measurement SW: DASY52, Version 52.8 (7); SEMCAD X Version 14.6.10 (7164)

Area Scan (61x81x1): Interpolated grid: dx=1.500 mm, dy=1.500 mm

Maximum value of SAR (interpolated) = 0.536 W/kg

Zoom Scan (5x5x7)/Cube 0: Measurement grid: dx=8mm, dy=8mm, dz=5mm

Reference Value = 23.221 V/m; Power Drift = -0.11 dB

Peak SAR (extrapolated) = 0.674 W/kg

SAR(1 g) = 0.457 W/kg; SAR(10 g) = 0.294 W/kg

Maximum value of SAR (measured) = 0.538 W/kg

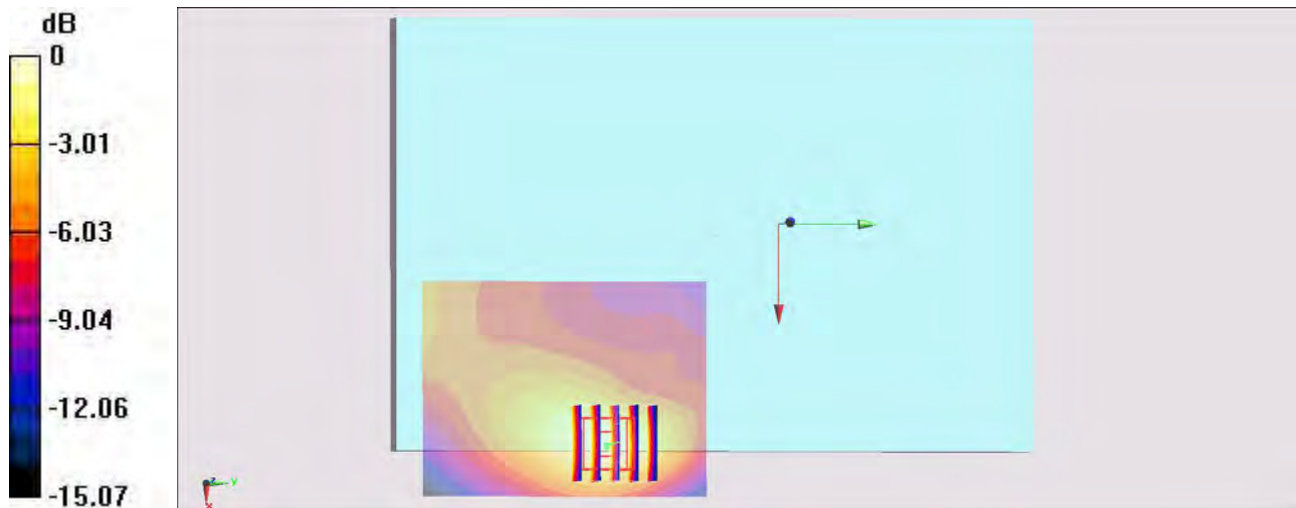

0 dB = 0.536 W/kg = -2.71 dBW/kg

#09_LTE Band 4_20M_QPSK_50_0_Bottom Face_0mm_Ch20175

Communication System: LTE ; Frequency: 1732.5 MHz;Duty Cycle: 1:1

Medium: MSL_1750_160625 Medium parameters used: $f = 1732.5$ MHz; $\sigma = 1.518$ S/m; $\epsilon_r = 55.649$;
 $\rho = 1000$ kg/m³

Ambient Temperature : 23.8°C; Liquid Temperature : 22.8°C

DASY5 Configuration

- Probe: ES3DV3 - SN3270; ConvF(4.95, 4.95, 4.95); Calibrated: 2015/9/28;
- Sensor-Surface: 3mm (Mechanical Surface Detection)
- Electronics: DAE4 Sn1399; Calibrated: 2015/11/23
- Phantom: ELI v4.0; Type: QDOVA001BB; Serial: 1026
- Measurement SW: DASY52, Version 52.8 (7); SEMCAD X Version 14.6.10 (7164)

Area Scan (61x81x1): Interpolated grid: dx=1.500 mm, dy=1.500 mm

Maximum value of SAR (interpolated) = 0.394 W/kg

Zoom Scan (5x5x7)/Cube 0: Measurement grid: dx=8mm, dy=8mm, dz=5mm

Reference Value = 12.715 V/m; Power Drift = -0.02 dB

Peak SAR (extrapolated) = 0.779 W/kg

SAR(1 g) = 0.364 W/kg; SAR(10 g) = 0.172 W/kg

Maximum value of SAR (measured) = 0.507 W/kg

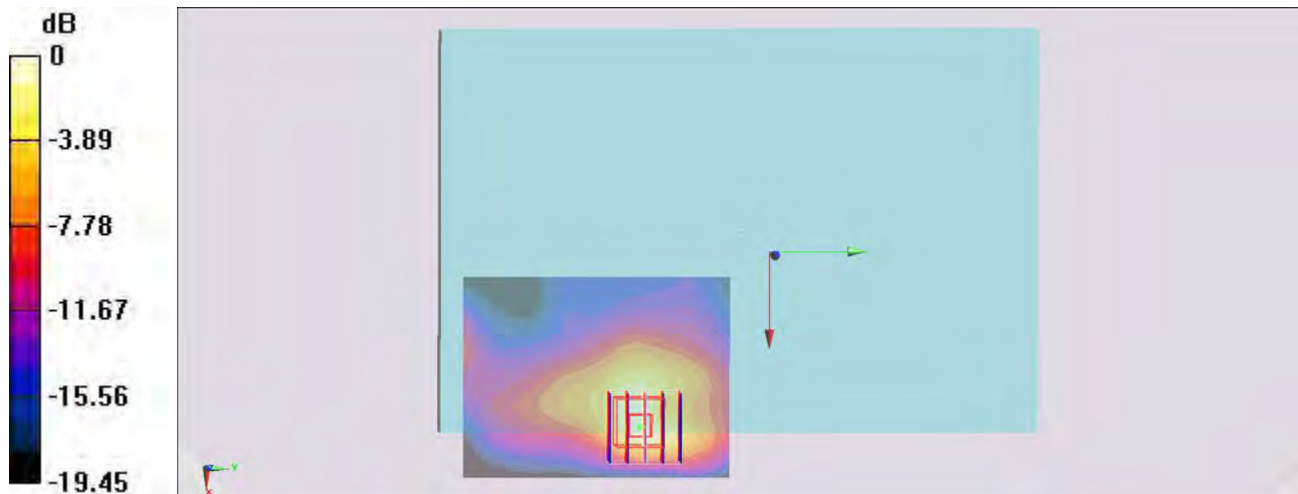

0 dB = 0.394 W/kg = -4.05 dBW/kg

#10_LTE Band 5_10M_QPSK_1_0_Bottom Face_14mm_Ch20525

Communication System: LTE ; Frequency: 836.5 MHz; Duty Cycle: 1:1

Medium: MSL_850_160621 Medium parameters used: $f = 836.5$ MHz; $\sigma = 1.004$ S/m; $\epsilon_r = 57.829$; $\rho = 1000$ kg/m³

Ambient Temperature : 23.5°C; Liquid Temperature : 22.5°C

DASY5 Configuration

- Probe: ES3DV3 - SN3270; ConvF(6.24, 6.24, 6.24); Calibrated: 2015/9/28;
- Sensor-Surface: 3mm (Mechanical Surface Detection)
- Electronics: DAE4 Sn1399; Calibrated: 2015/11/23
- Phantom: ELI v4.0; Type: QDOVA001BB; Serial: 1026
- Measurement SW: DASY52, Version 52.8 (7); SEMCAD X Version 14.6.10 (7164)

Area Scan (61x81x1): Interpolated grid: dx=1.500 mm, dy=1.500 mm

Maximum value of SAR (interpolated) = 0.517 W/kg

Zoom Scan (5x5x7)/Cube 0: Measurement grid: dx=8mm, dy=8mm, dz=5mm

Reference Value = 22.592 V/m; Power Drift = -0.11 dB

Peak SAR (extrapolated) = 0.651 W/kg

SAR(1 g) = 0.435 W/kg; SAR(10 g) = 0.277 W/kg

Maximum value of SAR (measured) = 0.514 W/kg

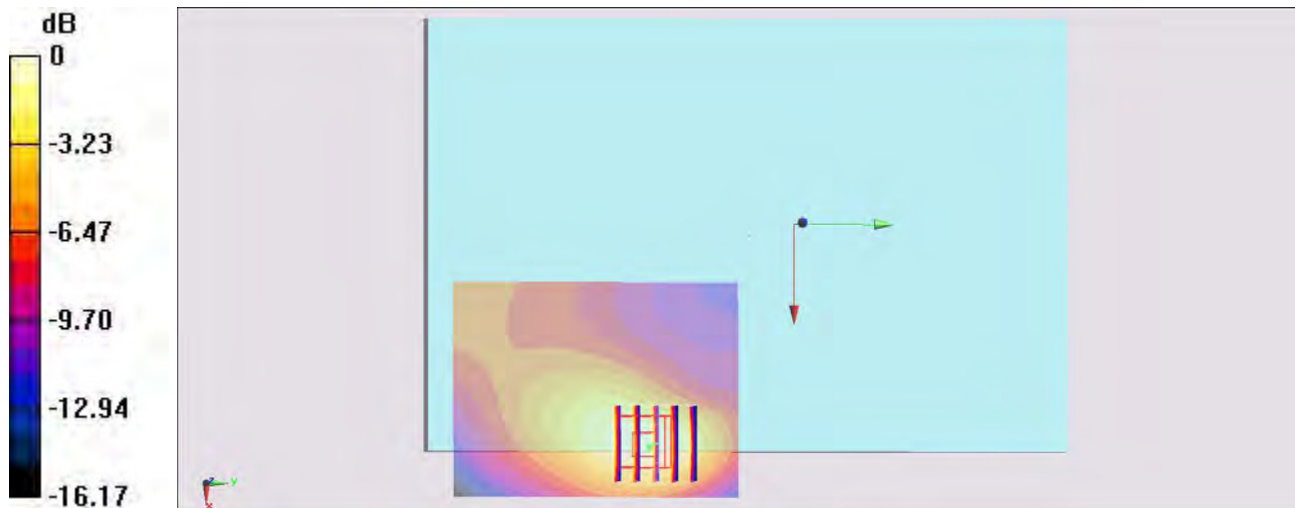

0 dB = 0.517 W/kg = -2.87 dBW/kg

#11_LTE Band 13_10M_QPSK_25_12_Bottom Face_0mm_Ch23230

Communication System: LTE ; Frequency: 782 MHz; Duty Cycle: 1:1

Medium: MSL_750_160623 Medium parameters used: $f = 782 \text{ MHz}$; $\sigma = 0.988 \text{ S/m}$; $\epsilon_r = 54.298$; $\rho = 1000 \text{ kg/m}^3$

Ambient Temperature : 23.5°C ; Liquid Temperature : 22.5°C

DASY5 Configuration

- Probe: ES3DV3 - SN3270; ConvF(6.3, 6.3, 6.3); Calibrated: 2015/9/28;
- Sensor-Surface: 3mm (Mechanical Surface Detection)
- Electronics: DAE4 Sn1399; Calibrated: 2015/11/23
- Phantom: ELI v4.0; Type: QDOVA001BB; Serial: 1026
- Measurement SW: DASY52, Version 52.8 (7); SEMCAD X Version 14.6.10 (7164)

Area Scan (61x81x1): Interpolated grid: $dx=1.500 \text{ mm}$, $dy=1.500 \text{ mm}$

Maximum value of SAR (interpolated) = 1.01 W/kg

Zoom Scan (5x5x7)/Cube 0: Measurement grid: $dx=8\text{mm}$, $dy=8\text{mm}$, $dz=5\text{mm}$

Reference Value = 32.174 V/m ; Power Drift = -0.14 dB

Peak SAR (extrapolated) = 1.51 W/kg

SAR(1 g) = 0.703 W/kg ; SAR(10 g) = 0.360 W/kg

Maximum value of SAR (measured) = 0.978 W/kg

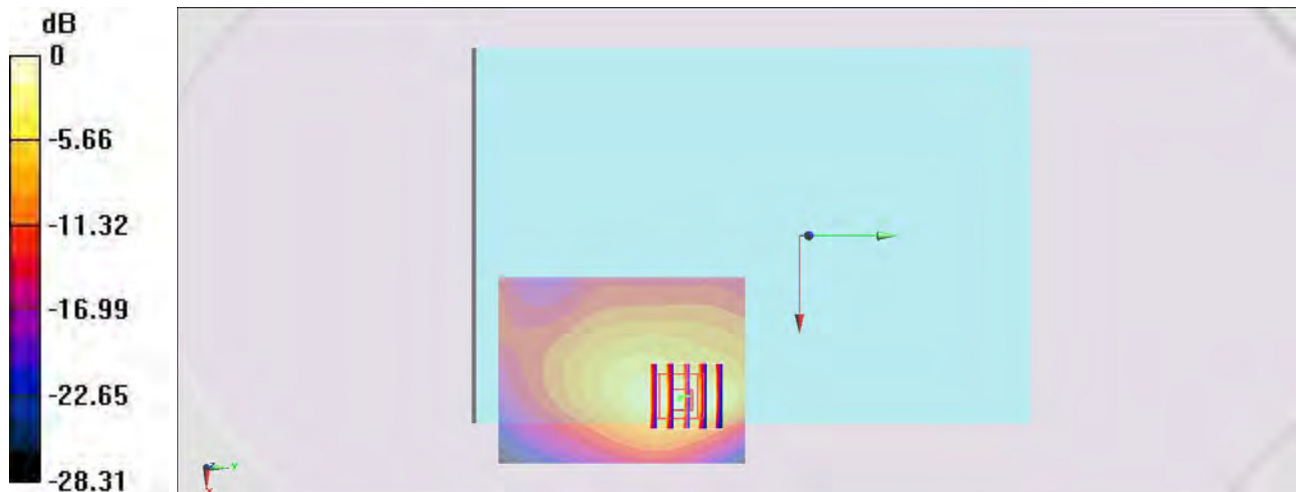

$0 \text{ dB} = 1.01 \text{ W/kg} = 0.04 \text{ dBW/kg}$

#12_LTE Band 17_10M_QPSK_25_12_Bottom Face_0mm_Ch23790

Communication System: LTE ; Frequency: 710 MHz;Duty Cycle: 1:1

Medium: MSL_750_160623 Medium parameters used: $f = 710$ MHz; $\sigma = 0.921$ S/m; $\epsilon_r = 55.029$; $\rho = 1000$ kg/m³

Ambient Temperature : 23.5°C; Liquid Temperature : 22.5°C

DASY5 Configuration

- Probe: ES3DV3 - SN3270; ConvF(6.3, 6.3, 6.3); Calibrated: 2015/9/28;
- Sensor-Surface: 3mm (Mechanical Surface Detection)
- Electronics: DAE4 Sn1399; Calibrated: 2015/11/23
- Phantom: ELI v4.0; Type: QDOVA001BB; Serial: 1026
- Measurement SW: DASY52, Version 52.8 (7); SEMCAD X Version 14.6.10 (7164)

Area Scan (61x81x1): Interpolated grid: dx=1.500 mm, dy=1.500 mm

Maximum value of SAR (interpolated) = 0.999 W/kg

Zoom Scan (5x5x7)/Cube 0: Measurement grid: dx=8mm, dy=8mm, dz=5mm

Reference Value = 32.928 V/m; Power Drift = -0.08 dB

Peak SAR (extrapolated) = 1.54 W/kg

SAR(1 g) = 0.707 W/kg; SAR(10 g) = 0.366 W/kg

Maximum value of SAR (measured) = 0.980 W/kg

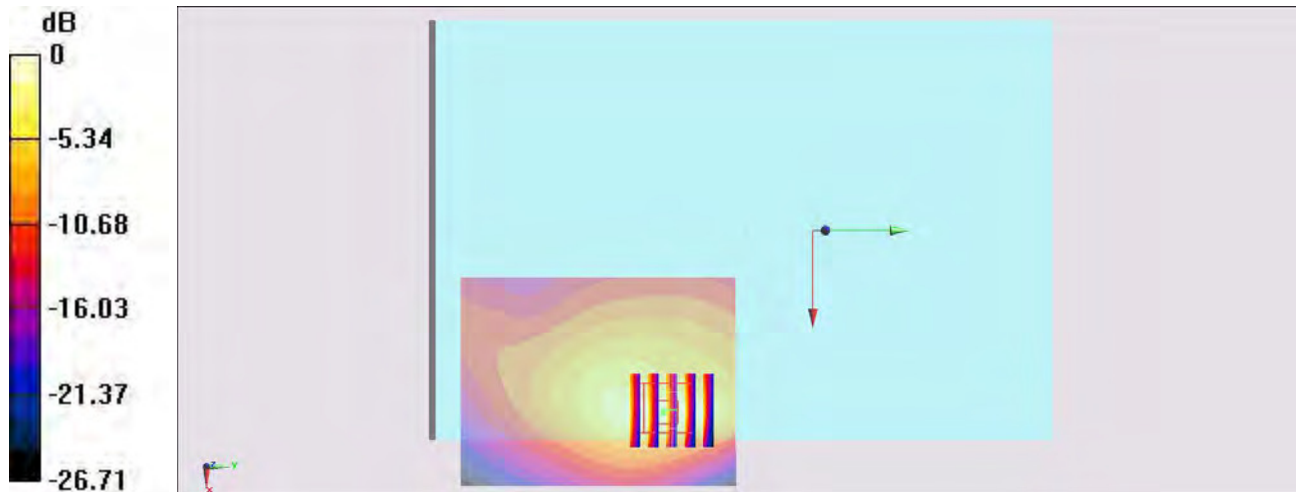

0 dB = 0.999 W/kg = -0.00 dBW/kg

#13_LTE Band 25_20M_QPSK_1_99_Edge 1_0mm_Ch26590

Communication System: LTE; Frequency: 1905 MHz; Duty Cycle: 1:1

Medium: MSL_1900_160624 Medium parameters used: $f = 1905 \text{ MHz}$; $\sigma = 1.532 \text{ S/m}$; $\epsilon_r = 53.837$; $\rho = 1000 \text{ kg/m}^3$

Ambient Temperature : $23.8 \text{ }^\circ\text{C}$; Liquid Temperature : $22.8 \text{ }^\circ\text{C}$

DASY5 Configuration

- Probe: ES3DV3 - SN3270; ConvF(4.78, 4.78, 4.78); Calibrated: 2015/9/28;
- Sensor-Surface: 3mm (Mechanical Surface Detection)
- Electronics: DAE4 Sn1399; Calibrated: 2015/11/23
- Phantom: ELI v4.0; Type: QDOVA001BB; Serial: 1026
- Measurement SW: DASY52, Version 52.8 (7); SEMCAD X Version 14.6.10 (7164)

Area Scan (51x81x1): Interpolated grid: $dx=1.500 \text{ mm}$, $dy=1.500 \text{ mm}$

Maximum value of SAR (interpolated) = 1.31 W/kg

Zoom Scan (5x5x7)/Cube 0: Measurement grid: $dx=8\text{mm}$, $dy=8\text{mm}$, $dz=5\text{mm}$

Reference Value = 9.828 V/m ; Power Drift = 0.10 dB

Peak SAR (extrapolated) = 1.60 W/kg

SAR(1 g) = 0.792 W/kg ; SAR(10 g) = 0.345 W/kg

Maximum value of SAR (measured) = 1.04 W/kg

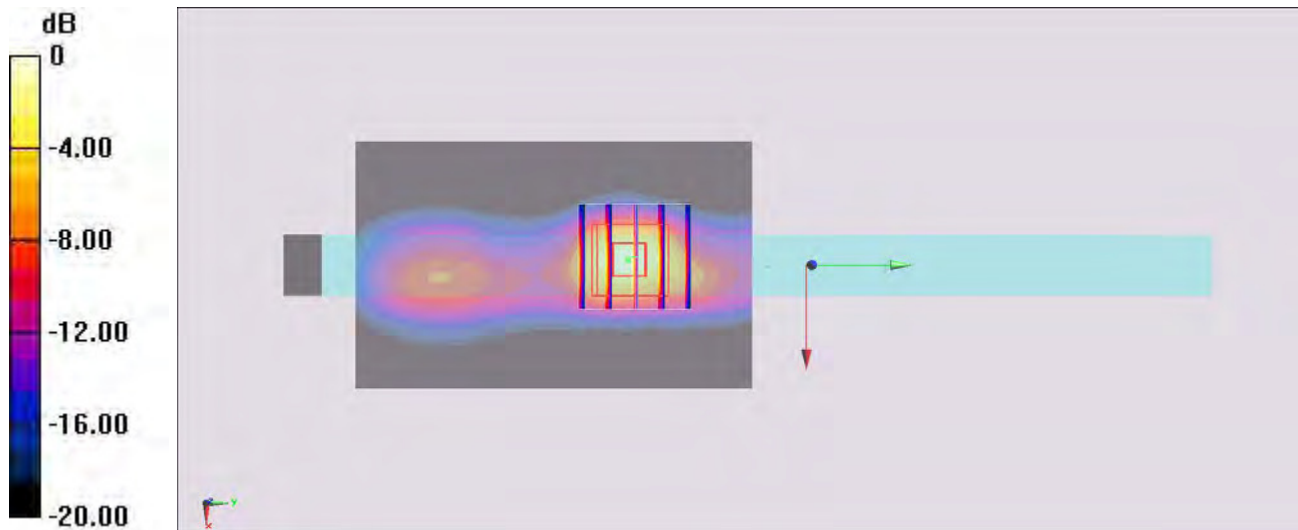

0 dB = $1.31 \text{ W/kg} = 1.17 \text{ dBW/kg}$

#14_WLAN2.4GHz_802.11b 1Mbps_Edge 2_0mm_Ch6;Ant 1

Communication System: 802.11b ; Frequency: 2437 MHz;Duty Cycle: 1:1.014

Medium: MSL_2450_160702 Medium parameters used: $f = 2437$ MHz; $\sigma = 1.97$ S/m; $\epsilon_r = 52.191$; $\rho = 1000$ kg/m³

Ambient Temperature : 23.5 °C ; Liquid Temperature : 22.5 °C

DASY5 Configuration

- Probe: EX3DV4 - SN3955; ConvF(7.53, 7.53, 7.53); Calibrated: 2015/11/24;
- Sensor-Surface: 1.4mm (Mechanical Surface Detection)
- Electronics: DAE4 Sn1399; Calibrated: 2015/11/23
- Phantom: ELI v4.0; Type: QDOVA001BB; Serial: 1026
- Measurement SW: DASY52, Version 52.8 (7); SEMCAD X Version 14.6.10 (7164)

Area Scan (51x101x1): Interpolated grid: dx=1.200 mm, dy=1.200 mm

Maximum value of SAR (interpolated) = 1.87 W/kg

Zoom Scan (7x7x7)/Cube 0: Measurement grid: dx=5mm, dy=5mm, dz=5mm

Reference Value = 18.717 V/m; Power Drift = 0.19 dB

Peak SAR (extrapolated) = 2.42 W/kg

SAR(1 g) = 0.974 W/kg; SAR(10 g) = 0.353 W/kg

Maximum value of SAR (measured) = 1.85 W/kg

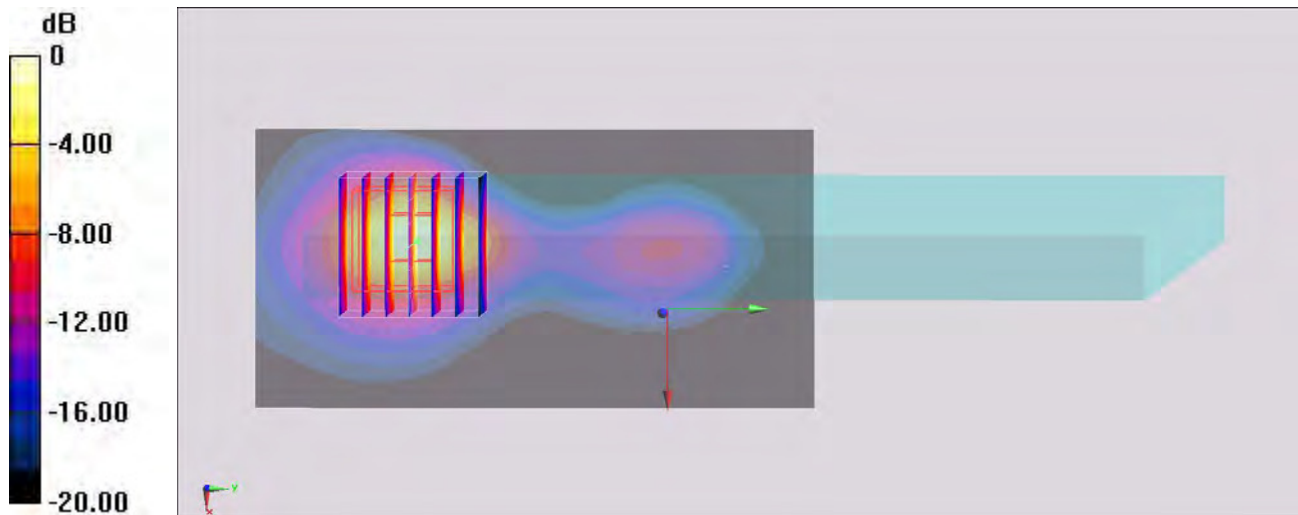

0 dB = 1.87 W/kg = 2.72 dBW/kg

#15_WLAN5GHz_802.11n-HT40 MCS0_Edge 2_0mm_Ch54;Ant 2

Communication System: 802.11n; Frequency: 5270 MHz; Duty Cycle: 1:1.152

Medium: MSL_5G_160702 Medium parameters used: $f = 5270$ MHz; $\sigma = 5.505$ S/m; $\epsilon_r = 47.304$; $\rho = 1000$ kg/m³

Ambient Temperature : 23.4 °C; Liquid Temperature : 22.4 °C

DASY5 Configuration

- Probe: EX3DV4 - SN3955; ConvF(4.42, 4.42, 4.42); Calibrated: 2015/11/24;
- Sensor-Surface: 1.4mm (Mechanical Surface Detection)
- Electronics: DAE4 Sn1399; Calibrated: 2015/11/23
- Phantom: ELI v4.0; Type: QDOVA001BB; Serial: 1026
- Measurement SW: DASY52, Version 52.8 (7); SEMCAD X Version 14.6.10 (7164)

Area Scan (61x121x1): Interpolated grid: dx=1.000 mm, dy=1.000 mm

Maximum value of SAR (interpolated) = 1.80 W/kg

Zoom Scan (7x7x7)/Cube 0: Measurement grid: dx=4mm, dy=4mm, dz=1.4mm

Reference Value = 16.533 V/m; Power Drift = 0.16 dB

Peak SAR (extrapolated) = 4.29 W/kg

SAR(1 g) = 0.978 W/kg; SAR(10 g) = 0.232 W/kg

Maximum value of SAR (measured) = 2.64 W/kg

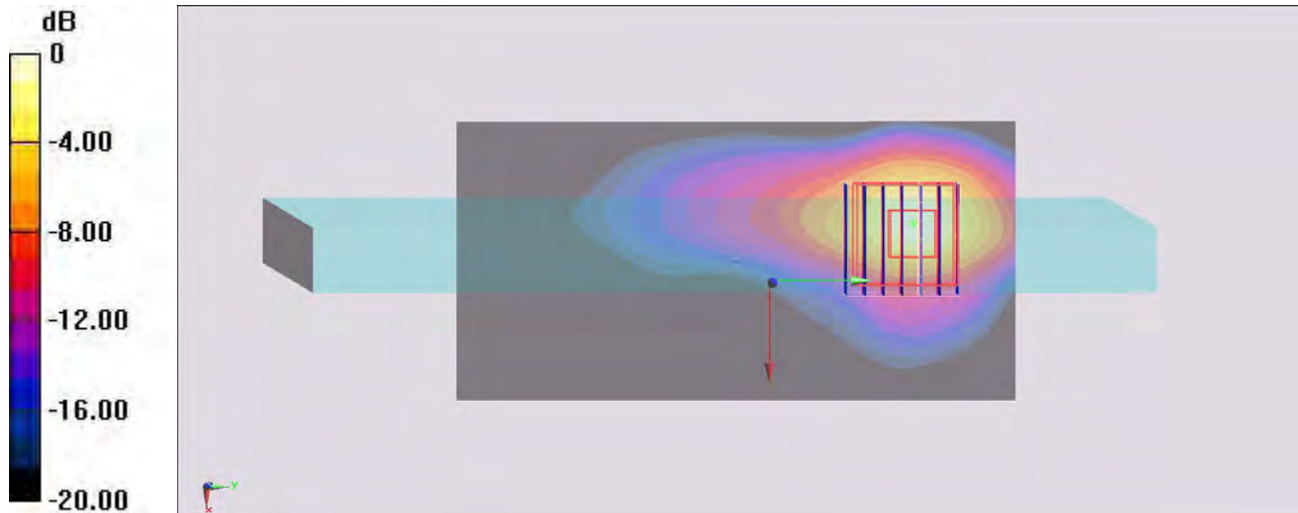

0 dB = 1.80 W/kg = 2.55 dBW/kg

#16_WLAN5GHz_802.11n-HT40 MCS0_Edge 2_0mm_Ch102;Ant 2

Communication System: 802.11n; Frequency: 5510 MHz; Duty Cycle: 1:1.152

Medium: MSL_5G_160702 Medium parameters used: $f = 5510$ MHz; $\sigma = 5.802$ S/m; $\epsilon_r = 46.917$; $\rho = 1000$ kg/m³

Ambient Temperature : 23.4 °C; Liquid Temperature : 22.4 °C

DASY5 Configuration

- Probe: EX3DV4 - SN3955; ConvF(3.81, 3.81, 3.81); Calibrated: 2015/11/24;
- Sensor-Surface: 1.4mm (Mechanical Surface Detection)
- Electronics: DAE4 Sn1399; Calibrated: 2015/11/23
- Phantom: ELI v4.0; Type: QDOVA001BB; Serial: 1026
- Measurement SW: DASY52, Version 52.8 (7); SEMCAD X Version 14.6.10 (7164)

Area Scan (61x121x1): Interpolated grid: dx=1.000 mm, dy=1.000 mm

Maximum value of SAR (interpolated) = 1.26 W/kg

Zoom Scan (7x7x7)/Cube 0: Measurement grid: dx=4mm, dy=4mm, dz=1.4mm

Reference Value = 14.497 V/m; Power Drift = 0.13 dB

Peak SAR (extrapolated) = 4.95 W/kg

SAR(1 g) = 1.14 W/kg; SAR(10 g) = 0.282 W/kg

Maximum value of SAR (measured) = 3.27 W/kg

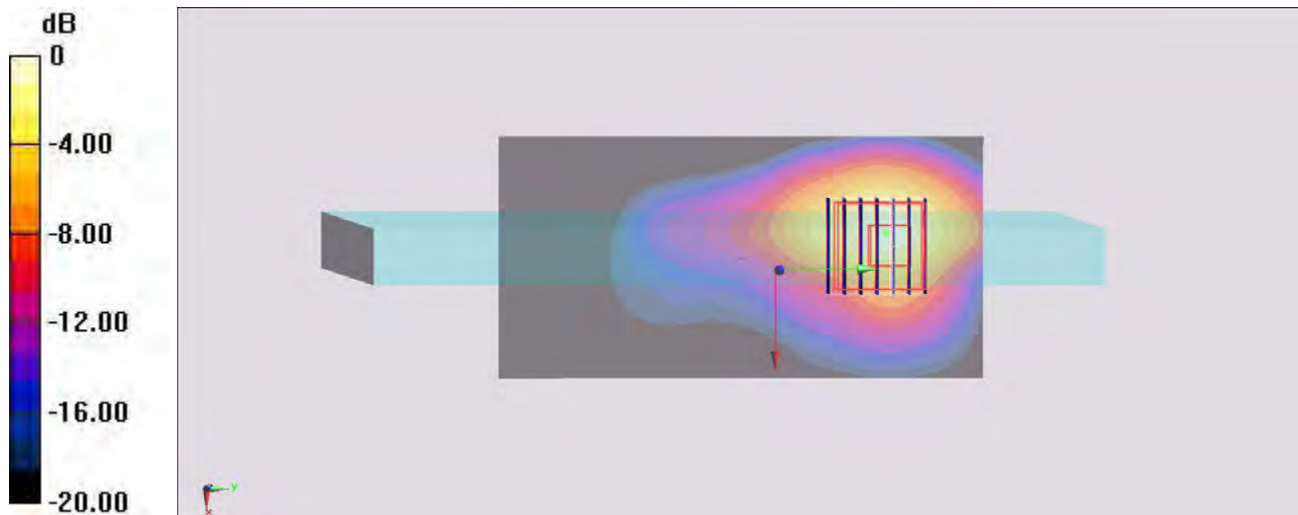

0 dB = 1.26 W/kg = 1.00 dBW/kg

#17_WLAN5GHz_802.11n-HT40 MCS0_Edge 2_0mm_Ch159;Ant 1

Communication System: 802.11n; Frequency: 5795 MHz; Duty Cycle: 1:1.152

Medium: MSL_5G_160702 Medium parameters used: $f = 5795$ MHz; $\sigma = 6.175$ S/m; $\epsilon_r = 46.456$; $\rho = 1000$ kg/m³

Ambient Temperature : 23.4 °C; Liquid Temperature : 22.4 °C

DASY5 Configuration

- Probe: EX3DV4 - SN3955; ConvF(3.92, 3.92, 3.92); Calibrated: 2015/11/24;
- Sensor-Surface: 1.4mm (Mechanical Surface Detection)
- Electronics: DAE4 Sn1399; Calibrated: 2015/11/23
- Phantom: ELI v4.0; Type: QDOVA001BB; Serial: 1026
- Measurement SW: DASY52, Version 52.8 (7); SEMCAD X Version 14.6.10 (7164)

Area Scan (61x121x1): Interpolated grid: dx=1.000 mm, dy=1.000 mm

Maximum value of SAR (interpolated) = 0.585 W/kg

Zoom Scan (7x7x7)/Cube 0: Measurement grid: dx=4mm, dy=4mm, dz=1.4mm

Reference Value = 16.303 V/m; Power Drift = -0.02 dB

Peak SAR (extrapolated) = 4.72 W/kg

SAR(1 g) = 1.02 W/kg; SAR(10 g) = 0.267 W/kg

Maximum value of SAR (measured) = 2.80 W/kg

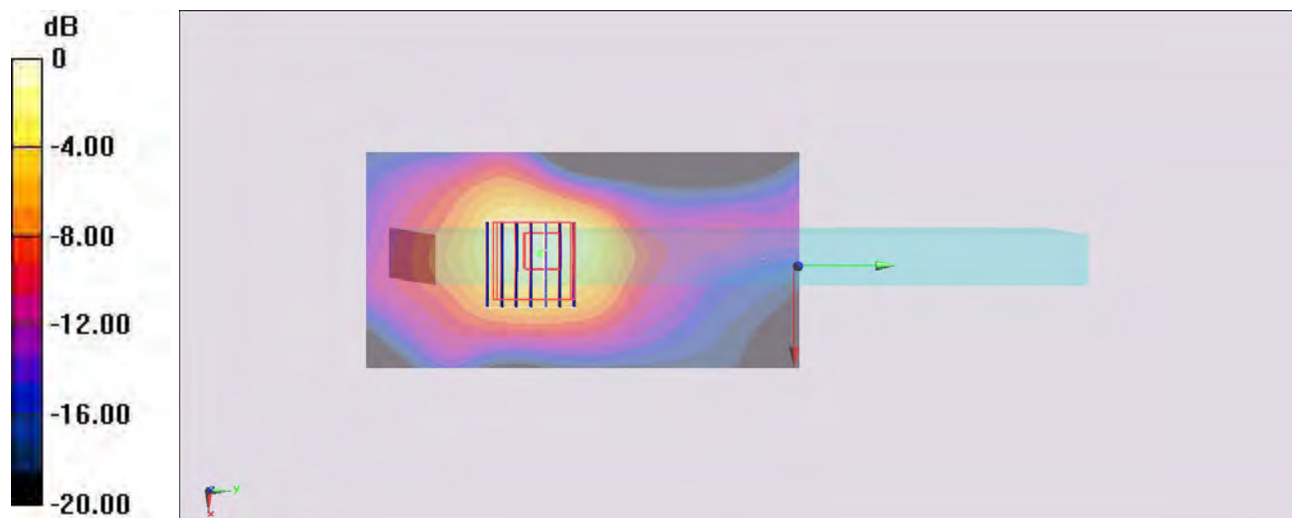

0 dB = 0.585 W/kg = -2.33 dBW/kg

#18_Bluetooth_1Mbps_Edge 2_0mm_Ch78

Communication System: Bluetooth ; Frequency: 2480 MHz;Duty Cycle: 1:1.2

Medium: MSL_2450_160702 Medium parameters used: $f = 2480$ MHz; $\sigma = 2.025$ S/m; $\epsilon_r = 52.017$; $\rho = 1000$ kg/m³

Ambient Temperature : 23.5 °C; Liquid Temperature : 22.5 °C

DASY5 Configuration

- Probe: EX3DV4 - SN3955; ConvF(7.53, 7.53, 7.53); Calibrated: 2015/11/24;
- Sensor-Surface: 1.4mm (Mechanical Surface Detection)
- Electronics: DAE4 Sn1399; Calibrated: 2015/11/23
- Phantom: ELI v4.0; Type: QDOVA001BB; Serial: 1026
- Measurement SW: DASY52, Version 52.8 (7); SEMCAD X Version 14.6.10 (7164)

Area Scan (51x101x1): Interpolated grid: dx=1.200 mm, dy=1.200 mm

Maximum value of SAR (interpolated) = 0.346 W/kg

Zoom Scan (7x7x7)/Cube 0: Measurement grid: dx=5mm, dy=5mm, dz=5mm

Reference Value = 11.040 V/m; Power Drift = 0.18 dB

Peak SAR (extrapolated) = 0.478 W/kg

SAR(1 g) = 0.187 W/kg; SAR(10 g) = 0.066 W/kg

Maximum value of SAR (measured) = 0.369 W/kg

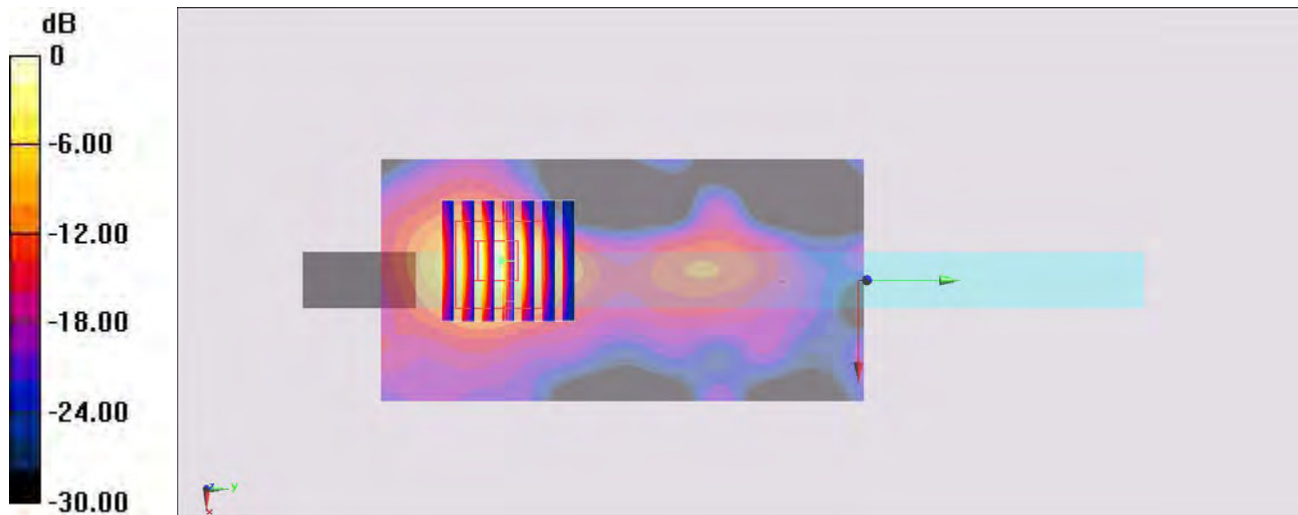

0 dB = 0.346 W/kg = -4.61 dBW/kg