



FCC RF TEST REPORT

FCC ID : UZ7ET45CA
Equipment : Tablet
Brand Name : Zebra
Model Name : ET45CA
Applicant : Zebra Technologies Corporation
1 Zebra Plaza, Holtsville, NY 11742
Manufacturer : Zebra Technologies Corporation
1 Zebra Plaza, Holtsville, NY 11742
Standard : 47 CFR Part 2, 22(H), 24(E), 27(L)
Classification : PCS Licensed Transmitter (PCB)
Test Date(S) : Jun. 22, 2022 ~ Jul. 18, 2022

We, Sporton International Inc. (Kunshan), would like to declare that the tested sample has been evaluated in accordance with the test procedures given in ANSI C63.26-2015 and has been in compliance with the applicable technical standards.

The test results in this report apply exclusively to the tested model / sample. Without written approval of Sporton International Inc. (Kunshan), the test report shall not be reproduced except in full.

Jason Jia



Approved by: Jason Jia

Sporton International Inc. (Kunshan)

No. 1098, Pengxi North Road, Kunshan Economic Development Zone Jiangsu Province 215300
People's Republic of China



Table of Contents

History of this test report..... 3

Summary of Test Result..... 4

1 General Description 5

 1.1 Product Feature of Equipment Under Test 5

 1.2 Product Specification of Equipment Under Test 6

 1.3 Modification of EUT 6

 1.4 Maximum ERP/EIRP Power and Emission Designator 7

 1.5 Testing Location 7

 1.6 Test Software 7

 1.7 Applicable Standards 8

2 Test Configuration of Equipment Under Test 9

 2.1 Test Mode..... 9

 2.2 Connection Diagram of Test System 10

 2.3 Support Unit used in test configuration 10

 2.4 Measurement Results Explanation Example 10

 2.5 Frequency List of Low/Middle/High Channels 11

3 Conducted Test Result 12

 3.1 Measuring Instruments..... 12

 3.2 Conducted Output Power and ERP/EIRP 13

 3.3 Peak-to-Average Ratio 14

 3.4 99% Occupied Bandwidth and 26dB Bandwidth Measurement..... 15

 3.5 Conducted Band Edge 16

 3.6 Conducted Spurious Emission 17

 3.7 Frequency Stability..... 18

4 Radiated Test Items 19

 4.1 Measuring Instruments..... 19

 4.2 Test Setup 19

 4.3 Test Result of Radiated Test..... 20

 4.4 Field Strength of Spurious Radiation Measurement 21

5 List of Measuring Equipment..... 22

6 Uncertainty of Evaluation 23

APPENDIX A. TEST RESULTS OF CONDUCTED TEST

APPENDIX B. TEST RESULTS OF RADIATED TEST

APPENDIX C. TEST SETUP PHOTOGRAPHS



History of this test report

Report No.	Version	Description	Issued Date
FG230412A	01	Initial issue of report	Aug. 16, 2022



Summary of Test Result

Report Clause	Ref Std. Clause	Test Items	Result (PASS/FAIL)	Remark
3.2	§2.1046	Conducted Output Power	Pass	-
	§22.913 (a)(2)	Effective Radiated Power (GSM 850) (WCDMA Band V)		
	§24.232 (c)	Equivalent Isotropic Radiated Power (GSM 1900) (WCDMA Band II)		
	§27.50 (d)(4)	Equivalent Isotropic Radiated Power (WCDMA Band IV)		
3.3	§24.232 (d)	Peak-to-Average Ratio	Pass	
3.4	§2.1049 §22.917 (b) §24.238 (b) §27.53 (g)	Occupied Bandwidth (GSM 850) (GSM 1900) (WCDMA Band V) (WCDMA Band II) (WCDMA Band IV)	Pass	-
3.5	§2.1051 §22.917 (a) §24.238 (a) §27.53 (g)	Band Edge Measurement (GSM 850) (GSM 1900) (WCDMA Band V) (WCDMA Band II) (WCDMA Band IV)	Pass	-
3.6	§2.1051 §22.917 (a) §24.238 (a) §27.53 (g)	Conducted Emission (GSM 850) (GSM 1900) (WCDMA Band V) (WCDMA Band II) (WCDMA Band IV)	Pass	-
3.7	§2.1055 §22.355 §24.235 §27.54	Frequency Stability Temperature & Voltage	Pass	-
4.4	§2.1053 §22.917 (a) §24.238 (a) §27.53 (h)	Field Strength of Spurious Radiation (GSM 850) (GSM 1900) (WCDMA Band V) (WCDMA Band II) (WCDMA Band IV)	Pass	Under limit 26.09 dB at 2472.000 MHz

Declaration of Conformity:

The test results with all measurement uncertainty excluded are presented in accordance with the regulation limits or requirements declared by manufacturers.

Comments and Explanations:

The declared of product specification for EUT presented in the report are provided by the manufacturer, and the manufacturer takes all the responsibilities for the accuracy of product specification.



1 General Description

1.1 Product Feature of Equipment Under Test

Product Feature	
Equipment	Tablet
Brand Name	Zebra
Model Name	ET45CA
FCC ID	UZ7ET45CA
HW Version	EV2-2
SW Version	ET45-userdebug 11 11-10-12.00-RG-U00-PRD-GSE MXJ release-keys
MFD	10MAY22
EUT Stage	Identical Prototype

Remark: The above EUT's information was declared by manufacturer.

Specification of Accessory				
Battery	Brand Name	Zebra	Model Number	BT-000455

Supported Unit used in test configuration and system				
AC Adapter	Brand Name	Zebra	Part Number	PWR-WUA5V12W0US
Earphone 1	Brand Name	Zebra	Part Number	HDST-35MM-PTVP-01
Earphone 2	Brand Name	Zebra	Part Number	HDST-USBC-PTT1-01
USB Cable (Type C to Type A)	Brand Name	Zebra	Part Number	CBL-TC5X-USBC2A-01
Type C-Audio Cable (Type C to 3.5mm)	Brand Name	Zebra	Part Number	ADP-USBC-35MM1-01

1.2 Product Specification of Equipment Under Test

Product Specification subjective to this standard	
Tx Frequency	GPRS/EDGE: 850: 824 MHz ~ 849 MHz 1900: 1850MHz ~ 1910MHz WCDMA: Band V: 824 MHz ~ 849 MHz Band II: 1850 MHz ~ 1910 MHz Band IV: 1710 MHz ~ 1755 MHz
Rx Frequency	GPRS/EDGE: 850: 869 MHz ~ 894 MHz 1900: 1930 MHz ~ 1990 MHz WCDMA: Band V: 869 MHz ~ 894 MHz Band II: 1930 MHz ~ 1990 MHz Band IV: 2110 MHz ~ 2155 MHz
Maximum Output Power to Antenna	<Ant. 0> GPRS/EDGE: 850: 33.42 dBm 1900: 30.49 dBm WCDMA: Band V: 23.17 dBm Band II: 23.32 dBm Band IV: 23.28 dBm
Antenna Gain	<Ant. 0> Cellular Band: 0.4 dBi PCS Band: 0.7 dBi AWS Band: 0.7 dBi
Antenna Type	IFA Antenna
Type of Modulation	GPRS: GMSK EDGE(MCS 0-4): GMSK / (MCS 5-9): 8PSK WCDMA : BPSK HSPA : QPSK HSPA+ : 16QAM(uplink is not supported) DC-HSDPA : 64QAM

1.3 Modification of EUT

No modifications are made to the EUT during all test items.



1.4 Maximum ERP/EIRP Power and Emission Designator

FCC Rule	Frequency Range (MHz)	System	Type of Modulation	Maximum ERP/EIRP (W)	Emission Designator
Part 22	824.2 ~ 848.8	GSM850 (GPRS)	GMSK	1.4689	245KGXW
Part 22	824.2 ~ 848.8	GSM850 (EDGE)	8PSK	0.2704	241KG7W
Part 22	826.4 ~846.6	WCDMA Band V RMC 12.2Kbps	QPSK	0.1387	4M15F9W
Part 24	1850.2 ~ 1909.8	GSM1900 (GPRS)	GMSK	1.3152	242KGXW
Part 24	1850.2 ~ 1909.8	GSM1900 (EDGE)	8PSK	0.4169	243KG7W
Part 24	1852.4 ~1907.6	WCDMA Band II RMC 12.2Kbps	QPSK	0.2523	4M16F9W
Part 27	1712.4 ~ 1752.6	WCDMA Band IV RMC 12.2Kbps	QPSK	0.2500	4M15F9W

1.5 Testing Location

Sporton International Inc. (Kunshan) is accredited to ISO/IEC 17025:2017 by American Association for Laboratory Accreditation with Certificate Number 5145.02.

Test Firm	Sporton International Inc. (Kunshan)		
Test Site Location	No. 1098, Pengxi North Road, Kunshan Economic Development Zone Jiangsu Province 215300 People's Republic of China TEL : +86-512-57900158 FAX : +86-512-57900958		
Test Site No.	Sporton Site No.	FCC Designation No.	FCC Test Firm Registration No.
	03CH04-KS TH01-KS	CN1257	314309

Note: The test site complies with ANSI C63.4 2014 requirement.

1.6 Test Software

Item	Site	Manufacturer	Name	Version
1.	03CH04-KS	AUDIX	E3	6.2009-8-24a



1.7 Applicable Standards

According to the specifications of the manufacturer, the EUT must comply with the requirements of the following standards:

- ♦ 47 CFR Part 2, 22(H), 24(E), 27(L)
- ♦ ANSI C63.26-2015
- ♦ FCC KDB 971168 D01 Power Meas. License Digital Systems v03r01
- ♦ FCC KDB 412172 D01 Determining ERP and EIRP v01r01

Remark:

1. All test items were verified and recorded according to the standards and without any deviation during the test.
2. This EUT has also been tested and complied with the requirements of FCC Part 15, Subpart B, recorded in a separate test report.



2 Test Configuration of Equipment Under Test

2.1 Test Mode

Antenna port conducted and radiated test items were performed according to KDB 971168 D01 Power Meas. License Digital Systems v03r01 with maximum output power.

For radiated measurement, pre-scanned in three orthogonal panels, X, Y, Z and accessory configurations. The worst-cases (X, Z Plane with adapter) were recorded in this report.

Radiated emissions were investigated as following frequency range:

1. 30 MHz to 9000 MHz for GSM850 and WCDMA Band V.
2. 30 MHz to 18000 MHz for WCDMA Band IV.
3. 30 MHz to 19100 MHz for GSM1900 and WCDMA Band II.

All modes and data rates and positions were investigated.

Test modes are chosen to be reported as the worst case configuration below:

Test Modes		
Band	Radiated TCs	Conducted TCs
GSM 850	<ul style="list-style-type: none"> ■ GPRS 1 Tx slots Link ■ EDGE 1 Tx slots Link 	<ul style="list-style-type: none"> ■ GPRS 1 Tx slots Link ■ EDGE 1 Tx slots Link
GSM 1900	<ul style="list-style-type: none"> ■ GPRS 1 Tx slots Link ■ EDGE 1 Tx slots Link 	<ul style="list-style-type: none"> ■ GPRS 1 Tx slots Link ■ EDGE 1 Tx slots Link
WCDMA Band V	<ul style="list-style-type: none"> ■ RMC 12.2Kbps Link 	<ul style="list-style-type: none"> ■ RMC 12.2Kbps Link
WCDMA Band II	<ul style="list-style-type: none"> ■ RMC 12.2Kbps Link 	<ul style="list-style-type: none"> ■ RMC 12.2Kbps Link
WCDMA Band IV	<ul style="list-style-type: none"> ■ RMC 12.2Kbps Link 	<ul style="list-style-type: none"> ■ RMC 12.2Kbps Link

2.2 Connection Diagram of Test System

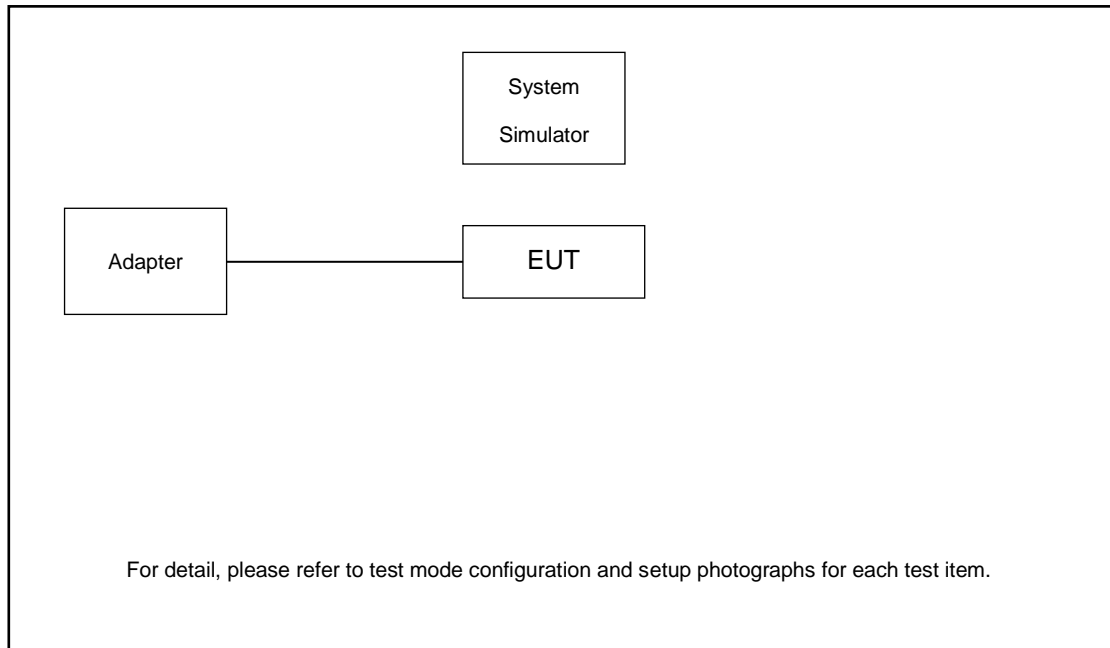

2.3 Support Unit used in test configuration

Item	Equipment	Brand Name	Model No.	FCC ID	Data Cable	Power Cord
1.	Power Supply	GWINSTEK	PSS-2002	N/A	N/A	Unshielded, 1.8 m
2.	Base Station	Anritsu	MT8820/8821	N/A	N/A	Unshielded, 1.8 m

2.4 Measurement Results Explanation Example

For all conducted test items:

The offset level is set in the spectrum analyzer to compensate the RF cable loss and attenuator factor between RF conducted output port and spectrum analyzer. With the offset compensation, the spectrum analyzer reading level will be exactly the RF output level.

The spectrum analyzer offset is derived from RF cable loss and attenuator factor.

Offset = RF cable loss + attenuator factor.

The following shows an offset computation example with RF cable loss 4.8 dB and a 10dB attenuator.

Example:

$$\begin{aligned} \text{Offset(dB)} &= \text{RF cable loss(dB)} + \text{attenuator factor(dB)} \\ &= 4.8 + 10 = 14.8 \text{ (dB)} \end{aligned}$$



2.5 Frequency List of Low/Middle/High Channels

Frequency List				
Band	Channel/Frequency(MHz)	Lowest	Middle	Highest
GSM850	Channel	128	189	251
	Frequency	824.2	836.4	848.8
WCDMA Band V	Channel	4132	4182	4233
	Frequency	826.4	836.4	846.6
GSM1900	Channel	512	661	810
	Frequency	1850.2	1880.0	1909.8
WCDMA Band II	Channel	9262	9400	9538
	Frequency	1852.4	1880.0	1907.6
WCDMA Band IV	Channel	1312	1413	1513
	Frequency	1712.4	1732.6	1752.6

3 Conducted Test Result

3.1 Measuring Instruments

See list of measuring instruments of this test report.

3.1.1 Test Setup

3.1.2 Conducted Output Power



3.1.3 Peak-to-Average Ratio, Occupied Bandwidth, Conducted Band-Edge and Conducted Spurious Emission

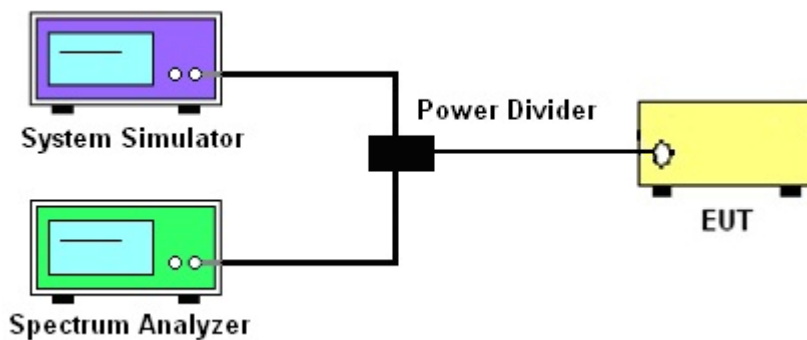

3.1.4 Frequency Stability

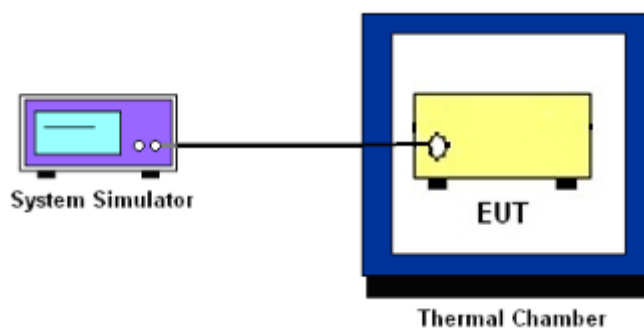

3.1.5 Test Result of Conducted Test

Please refer to Appendix A.



3.2 Conducted Output Power and ERP/EIRP

3.2.1 Description of the Conducted Output Power and ERP/EIRP

A system simulator was used to establish communication with the EUT. Its parameters were set to enforce EUT transmitting at the maximum power. The measured power in the radio frequency on the transmitter output terminals shall be reported.

The ERP of mobile transmitters must not exceed 7 Watts for GSM850 and WCDMA Band V.

The EIRP of mobile transmitters must not exceed 2 Watts for GSM1900 and WCDMA Band II.

The EIRP of mobile transmitters must not exceed 1 Watts for WCDMA Band IV.

According to KDB 412172 D01 Power Approach,

$EIRP = P_T + G_T - L_C$, $ERP = EIRP - 2.15$, where

P_T = transmitter output power in dBm

G_T = gain of the transmitting antenna in dBi

L_C = signal attenuation in the connecting cable between the transmitter and antenna in dB

3.2.2 Test Procedures

1. The transmitter output port was connected to the system simulator.
2. Set EUT at maximum power through system simulator.
3. Select lowest, middle, and highest channels for each band and different modulation.
4. Measure the maximum burst average power for GSM and maximum average power for other modulation signal.



3.3 Peak-to-Average Ratio

3.3.1 Description of the PAR Measurement

The peak-to-average ratio (PAR) of the transmission may not exceed 13 dB.

3.3.2 Test Procedures

The testing follows ANSI C63.26 Section 5.2.3.4 (CCDF)

1. The EUT was connected to spectrum analyzer and system simulator via a power divider.
2. Set EUT to transmit at maximum output power.
3. When the duty cycle is less than 98%, then signal gating will be implemented on the spectrum analyzer by triggering from the system simulator.
4. Set the CCDF (Complementary Cumulative Distribution Function) option of the spectrum analyzer.
5. Record the maximum PAPR level associated with a probability of 0.1%.

3.4 99% Occupied Bandwidth and 26dB Bandwidth Measurement

3.4.1 Description of 99% Occupied Bandwidth and 26dB Bandwidth Measurement

The occupied bandwidth is the width of a frequency band such that, below the lower and above the upper frequency limits, the mean powers emitted are each equal to a specified percentage 0.5% of the total mean transmitted power.

The 26 dB emission bandwidth is defined as the frequency range between two points, one above and one below the carrier frequency, at which the spectral density of the emission is attenuated 26 dB below the maximum in-band spectral density of the modulated signal. Spectral density (power per unit bandwidth) is to be measured with a detector of resolution bandwidth equal to approximately 1.0% of the emission bandwidth.

3.4.2 Test Procedures

The testing follows ANSI C63.26 Section 5.4

1. The EUT was connected to spectrum analyzer and system simulator via a power divider.
2. The spectrum analyzer center frequency is set to the nominal EUT channel center frequency. The span range for the spectrum analyzer shall be between two and five times the anticipated OBW.
3. The nominal resolution bandwidth (RBW) shall be in the range of 1 to 5 % of the anticipated OBW, and the VBW shall be at least 3 times the RBW.
4. Set the detection mode to peak, and the trace mode to max hold.
5. Determine the reference value: Set the EUT to transmit a modulated signal. Allow the trace to stabilize. Set the spectrum analyzer marker to the highest level of the displayed trace.
(this is the reference value)
6. Determine the “-26 dB down amplitude” as equal to (Reference Value – X).
7. Place two markers, one at the lowest and the other at the highest frequency of the envelope of the spectral display such that each marker is at or slightly below the “-X dB down amplitude” determined in step 6. If a marker is below this “-X dB down amplitude” value it shall be placed as close as possible to this value. The OBW is the positive frequency difference between the two markers.
8. Use the 99 % power bandwidth function of the spectrum analyzer and report the measured bandwidth.



3.5 Conducted Band Edge

3.5.1 Description of Conducted Band Edge Measurement

The power of any emission outside of the authorized operating frequency ranges must be lower than the transmitter power (P) by a factor of at least $43 + 10 \log (P)$ dB.

3.5.2 Test Procedures

The testing follows ANSI C63.26 Section 5.7.

1. The EUT was connected to the spectrum analyzer and system simulator via a power divider.
2. The RF output of EUT was connected to the spectrum analyzer by an RF cable and attenuator. The path loss was compensated to the results for each measurement.
3. The band edges of low and high channels for the highest RF powers were measured.
4. The RF fundamental frequency should be excluded against the limit line in the operating frequency band.
5. The limit line is derived from $43 + 10\log(P)$ dB below the transmitter power P(Watts)



3.6 Conducted Spurious Emission

3.6.1 Description of Conducted Spurious Emission Measurement

The power of any emission outside of the authorized operating frequency ranges must be lower than the transmitter power (P) by a factor of at least $43 + 10 \log (P)$ dB.

It is measured by means of a calibrated spectrum analyzer and scanned from 30 MHz up to a frequency including its 10th harmonic.

3.6.2 Test Procedures

The testing follows ANSI C63.26 Section 5.7

1. The EUT was connected to the spectrum analyzer and system simulator via a power divider.
2. The RF output of EUT was connected to the spectrum analyzer by an RF cable and attenuator. The path loss was compensated to the results for each measurement.
3. The middle channel for the highest RF power within the transmitting frequency was measured.
4. The conducted spurious emission for the whole frequency range was taken.
5. The RF fundamental frequency should be excluded against the limit line in the operating frequency band.
6. The limit line is derived from $43 + 10\log(P)$ dB below the transmitter power P(Watts)

3.7 Frequency Stability

3.7.1 Description of Frequency Stability Measurement

22.355

The frequency stability shall be measured by variation of ambient temperature and variation of primary supply voltage to ensure that the fundamental emission stays within the authorized frequency block. The frequency stability of the transmitter shall be maintained within $\pm 0.00025\%$ ($\pm 2.5\text{ppm}$) of the center frequency.

24.235 & 27.54

The frequency stability shall be sufficient to ensure that the fundamental emission stays within the authorized frequency block.

3.7.2 Test Procedures for Temperature Variation

The testing follows ANSI C63.26 section 5.6.4

1. The EUT was set up in the thermal chamber and connected with the system simulator.
2. With power OFF, the temperature was decreased to -30°C and the EUT was stabilized before testing. Power was applied and the maximum change in frequency was recorded within one minute.
3. With power OFF, the temperature was raised in 10°C steps up to 50°C . The EUT was stabilized at each step for at least half an hour. Power was applied and the maximum frequency change was recorded within one minute.

3.7.3 Test Procedures for Voltage Variation

The testing follows ANSI C63.26 section 5.6.5.

1. The EUT was placed in a temperature chamber at $20\pm 5^{\circ}\text{C}$ and connected with the system simulator.
2. The power supply voltage to the EUT was varied from 85% to 115% of the nominal value measured at the input to the EUT.
3. The variation in frequency was measured for the worst case.

4 Radiated Test Items

4.1 Measuring Instruments

See list of measuring instruments of this test report.

4.2 Test Setup

For radiated test below 30MHz

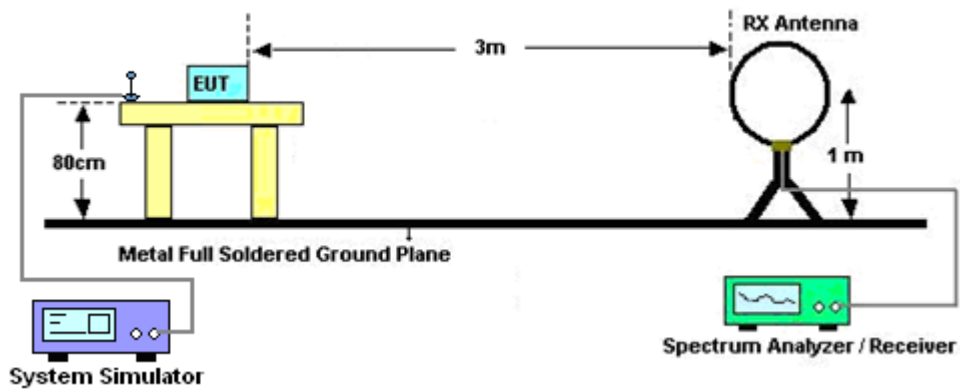

For radiated test from 30MHz to 1GHz

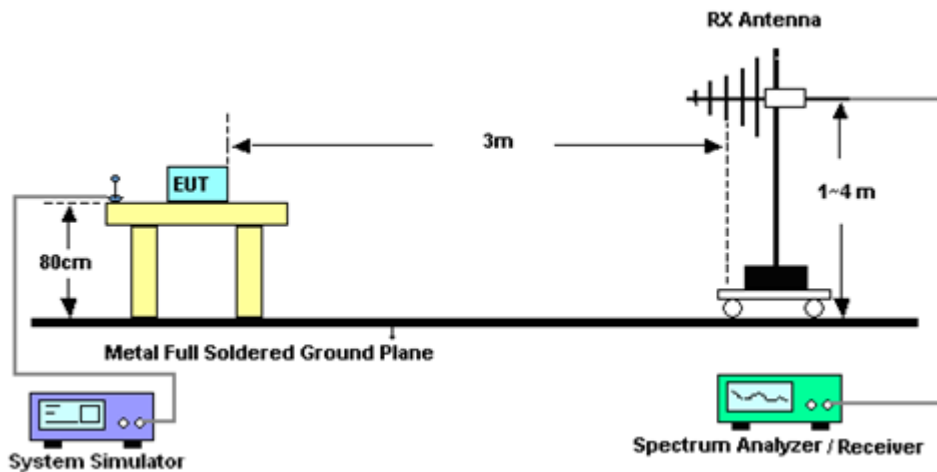

For radiated test above 1GHz

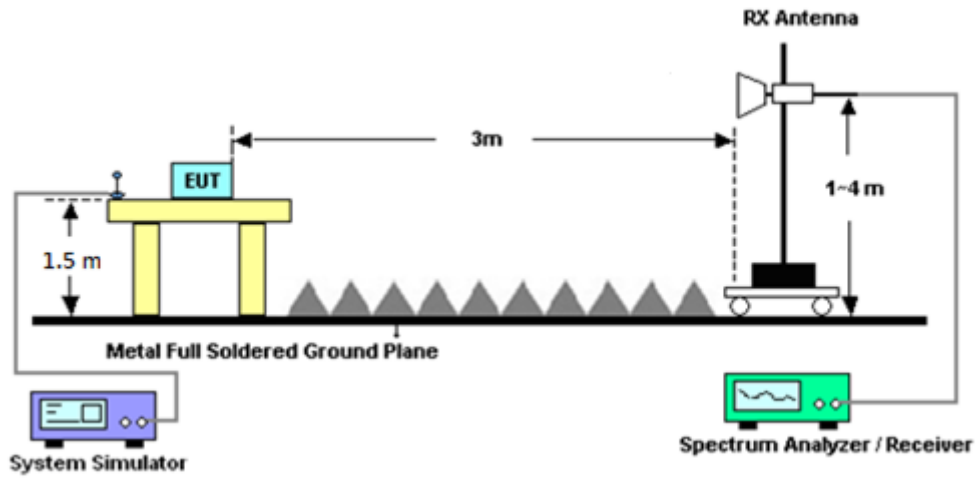

4.3 Test Result of Radiated Test

Please refer to Appendix B.

Note:

The low frequency, which started from 9 kHz to 30MHz, was pre-scanned and the result which was 20dB lower than the limit line was not reported.



4.4 Field Strength of Spurious Radiation Measurement

4.4.1 Description of Field Strength of Spurious Radiated Measurement

The power of any emission outside of the authorized operating frequency ranges must be attenuated below the transmitter power (P) by a factor of at least $43 + 10 \log (P)$ dB. The spectrum is scanned from 30 MHz up to a frequency including its 10th harmonic.

4.4.2 Test Procedures

The testing follows ANSI C63.26 Section 5.5

1. The EUT was placed on a rotatable wooden table 0.8 meters for frequency below 1GHz and 1.5 meter for frequency above 1GHz above the ground.
2. The EUT was set 3 meters from the receiving antenna, which was mounted on the antenna tower.
3. The table was rotated 360 degrees to determine the position of the highest spurious emission.
4. The height of the receiving antenna is varied between one meter and four meters to search for the maximum spurious emission for both horizontal and vertical polarizations.
5. Make the measurement with the spectrum analyzer's RBW = 1MHz, VBW = 3MHz, taking record of maximum spurious emission.
6. A horn antenna was substituted in place of the EUT and was driven by a signal generator.
7. Tune the output power of signal generator to the same emission level with EUT maximum spurious emission.
8. Taking the record of output power at antenna port.
9. Repeat step 7 to step 8 for another polarization.
10. $EIRP (dBm) = S.G. Power - Tx Cable Loss + Tx Antenna Gain$
11. $ERP (dBm) = EIRP - 2.15$
12. The RF fundamental frequency should be excluded against the limit line in the operating frequency band.
13. The limit line is derived from $43 + 10\log(P)$ dB below the transmitter power P(Watts)



5 List of Measuring Equipment

Instrument	Manufacturer	Model No.	Serial No.	Characteristics	Calibration Date	Test Date	Due Date	Remark
Spectrum Analyzer	R&S	FSV40	101040	10Hz~40GHz	Oct. 14, 2021	Jun. 22, 2022~ Jul. 18, 2022	Oct. 13, 2022	Conducted (TH01-KS)
Power divider	STI	STI08-0055	-	0.5~40GHz	Aug. 26, 2021	Jun. 22, 2022~ Jul. 18, 2022	Aug. 25, 2022	Conducted (TH01-KS)
Temperature & humidity chamber	Hongzhan	LP-150U	H2014011440	-40~+150°C 20%~95%RH	Jul. 12, 2021	Jun. 22, 2022~ Jul. 18, 2022	Jul. 11, 2022	Conducted (TH01-KS)
Temperature & humidity chamber	Hongzhan	LP-150U	H2014011440	-40~+150°C 20%~95%RH	Jul. 11, 2022		Jul. 10, 2023	Conducted (TH01-KS)
EXA Spectrum Analyzer	Keysight	N9010B	MY57541079	10Hz-44G,MAX 30dB	Oct. 14, 2022	Jun. 28, 2022	Oct. 13, 2023	Radiation (03CH04-KS)
Loop Antenna	R&S	HFH2-Z2	100321	9kHz~30MHz	Oct. 30, 2021	Jun. 28, 2022	Oct. 29, 2022	Radiation (03CH04-KS)
Bilog Antenna	TeseQ	CBL6111D	49922	30MHz-1GHz	May 24, 2022	Jun. 28, 2022	May 23, 2023	Radiation (03CH04-KS)
Horn Antenna	Schwarzbeck	BBHA9120D	1284	1GHz~18GHz	Jan. 05, 2022	Jun. 28, 2022	Jan. 04, 2023	Radiation (03CH04-KS)
SHF-EHF Horn	Com-power	AH-840	101070	18GHz~40GHz	Jan. 05, 2022	Jun. 28, 2022	Jan. 04, 2023	Radiation (03CH04-KS)
Amplifier	SONOMA	310N	187289	9KHz-1GHz	Jan. 05, 2022	Jun. 28, 2022	Jan. 04, 2023	Radiation (03CH04-KS)
Amplifier	MITEQ	EM18G40G GA	060728	18~40GHz	Jan. 05, 2022	Jun. 28, 2022	Jan. 04, 2023	Radiation (03CH04-KS)
high gain Amplifier	EM	EM01G18G A	060839	1Ghz-18Ghz	Oct. 14, 2021	Jun. 28, 2022	Oct. 13, 2022	Radiation (03CH04-KS)
Amplifier	Keysight	83017A	MY57280106	500MHz~26.5GHz	Oct. 13, 2021	Jun. 28, 2022	Oct. 12, 2022	Radiation (03CH04-KS)
AC Power Source	Chroma	61601	F104090004	N/A	NCR	Jun. 28, 2022	NCR	Radiation (03CH04-KS)
Turn Table	ChamPro	EM 1000-T	060762-T	0~360 degree	NCR	Jun. 28, 2022	NCR	Radiation (03CH04-KS)
Antenna Mast	ChamPro	EM 1000-A	060762-A	1 m~4 m	NCR	Jun. 28, 2022	NCR	Radiation (03CH04-KS)

NCR: No Calibration Required



6 Uncertainty of Evaluation

Uncertainty of Radiated Emission Measurement (30 MHz ~ 1000 MHz)

Measuring Uncertainty for a Level of Confidence of 95% ($U = 2Uc(y)$)	3.3dB
---	-------

Uncertainty of Radiated Emission Measurement (1 GHz ~ 18 GHz)

Measuring Uncertainty for a Level of Confidence of 95% ($U = 2Uc(y)$)	2.8dB
---	-------

Uncertainty of Radiated Emission Measurement (18 GHz ~ 40 GHz)

Measuring Uncertainty for a Level of Confidence of 95% ($U = 2Uc(y)$)	2.8dB
---	-------



Appendix A. Test Results of Conducted Test

Test Engineer :	Lex Wu	Temperature :	22~23°C
		Relative Humidity :	40~42%

Conducted Output Power(Average power) and ERP/EIRP

GSM850	Burst Average Power (dBm)			ERP(W)		
	128	189	251	L	M	H
TX Channel	824.2	836.4	848.8			
Frequency (MHz)	824.2	836.4	848.8	L	M	H
GPRS 1 Tx slot	33.37	33.42	33.35	1.4521	1.4689	1.4454
GPRS 2 Tx slots	30.80	30.95	30.73	0.8035	0.8318	0.7907
GPRS 3 Tx slots	28.67	28.98	28.71	0.4920	0.5284	0.4966
GPRS 4 Tx slots	26.24	26.34	26.18	0.2812	0.2877	0.2773
EDGE 1 Tx slot	25.89	26.07	25.95	0.2594	0.2704	0.2630
EDGE 2 Tx slots	25.76	25.82	25.74	0.2518	0.2553	0.2506
EDGE 3 Tx slots	25.64	25.69	25.62	0.2449	0.2477	0.2438
EDGE 4 Tx slots	25.52	25.57	25.55	0.2382	0.2410	0.2399

GSM1900	Burst Average Power (dBm)			EIRP(W)		
	512	661	810	L	M	H
TX Channel	1850.2	1880	1909.8			
Frequency (MHz)	1850.2	1880	1909.8	L	M	H
GPRS 1 Tx slot	30.31	30.49	30.30	1.2618	1.3152	1.2589
GPRS 2 Tx slots	28.16	28.05	27.96	0.7691	0.7499	0.7345
GPRS 3 Tx slots	25.76	25.79	25.83	0.4426	0.4457	0.4498
GPRS 4 Tx slots	23.63	23.71	23.67	0.2710	0.2761	0.2735
EDGE 1 Tx slot	25.50	25.35	25.30	0.4169	0.4027	0.3981
EDGE 2 Tx slots	25.18	24.98	25.03	0.3873	0.3698	0.3741
EDGE 3 Tx slots	24.81	24.76	24.92	0.3556	0.3516	0.3648
EDGE 4 Tx slots	24.57	24.61	24.54	0.3365	0.3396	0.3342



Band		WCDMA V			ERP(W)		
TX Channel		4132	4182	4233			
Rx Channel		4357	4407	4458			
Frequency (MHz)		826.4	836.4	846.6	L	M	H
3GPP Rel 99	RMC 12.2Kbps	23.15	23.17	22.99	0.1380	0.1387	0.1330
3GPP Rel 6	HSDPA Subtest-1	21.76	22.13	21.84	0.1002	0.1091	0.1021
3GPP Rel 6	HSDPA Subtest-2	21.86	21.90	22.00	0.1026	0.1035	0.1059
3GPP Rel 6	HSDPA Subtest-3	21.40	21.55	21.40	0.0923	0.0955	0.0923
3GPP Rel 6	HSDPA Subtest-4	21.47	21.54	21.42	0.0938	0.0953	0.0927
3GPP Rel 8	DC-HSDPA Subtest-1	21.92	22.08	21.84	0.1040	0.1079	0.1021
3GPP Rel 8	DC-HSDPA Subtest-2	21.73	21.87	21.94	0.0995	0.1028	0.1045
3GPP Rel 8	DC-HSDPA Subtest-3	21.38	21.54	21.45	0.0918	0.0953	0.0933
3GPP Rel 8	DC-HSDPA Subtest-4	21.26	21.53	21.25	0.0893	0.0951	0.0891
3GPP Rel 6	HSUPA Subtest-1	21.78	22.00	21.91	0.1007	0.1059	0.1038
3GPP Rel 6	HSUPA Subtest-2	19.94	20.28	19.88	0.0659	0.0713	0.0650
3GPP Rel 6	HSUPA Subtest-3	20.89	21.04	20.74	0.0820	0.0849	0.0793
3GPP Rel 6	HSUPA Subtest-4	19.81	20.06	19.96	0.0640	0.0678	0.0662
3GPP Rel 6	HSUPA Subtest-5	21.83	22.13	21.86	0.1019	0.1091	0.1026



Band		WCDMA IV			EIRP(W)		
TX Channel		1312	1413	1513			
Rx Channel		1537	1638	1738			
Frequency (MHz)		1712.4	1732.6	1752.6	L	M	H
3GPP Rel 99	RMC 12.2Kbps	23.11	23.28	23.18	0.2404	0.2500	0.2443
3GPP Rel 6	HSDPA Subtest-1	21.98	22.22	21.87	0.1854	0.1959	0.1807
3GPP Rel 6	HSDPA Subtest-2	21.96	22.03	22.01	0.1845	0.1875	0.1866
3GPP Rel 6	HSDPA Subtest-3	21.48	21.69	21.45	0.1652	0.1734	0.1641
3GPP Rel 6	HSDPA Subtest-4	21.48	21.66	21.52	0.1652	0.1722	0.1667
3GPP Rel 8	DC-HSDPA Subtest-1	21.94	22.05	21.93	0.1837	0.1884	0.1832
3GPP Rel 8	DC-HSDPA Subtest-2	21.91	21.97	21.92	0.1824	0.1849	0.1828
3GPP Rel 8	DC-HSDPA Subtest-3	21.61	21.65	21.55	0.1702	0.1718	0.1679
3GPP Rel 8	DC-HSDPA Subtest-4	21.44	21.61	21.48	0.1637	0.1702	0.1652
3GPP Rel 6	HSUPA Subtest-1	21.88	22.16	21.97	0.1811	0.1932	0.1849
3GPP Rel 6	HSUPA Subtest-2	20.01	20.37	20.08	0.1178	0.1279	0.1197
3GPP Rel 6	HSUPA Subtest-3	21.00	21.06	20.91	0.1479	0.1500	0.1449
3GPP Rel 6	HSUPA Subtest-4	19.85	20.14	19.98	0.1135	0.1213	0.1169
3GPP Rel 6	HSUPA Subtest-5	21.96	22.10	21.92	0.1845	0.1905	0.1828



Band		WCDMA II			EIRP(W)		
TX Channel		9262	9400	9538			
Rx Channel		9662	9800	9938			
Frequency (MHz)		1852.4	1880	1907.6	L	M	H
3GPP Rel 99	RMC 12.2Kbps	23.27	23.32	23.30	0.2495	0.2523	0.2512
3GPP Rel 6	HSDPA Subtest-1	21.89	22.21	22.02	0.1816	0.1954	0.1871
3GPP Rel 6	HSDPA Subtest-2	21.91	22.19	22.07	0.1824	0.1945	0.1892
3GPP Rel 6	HSDPA Subtest-3	21.37	21.68	21.54	0.1611	0.1730	0.1675
3GPP Rel 6	HSDPA Subtest-4	21.61	21.60	21.66	0.1702	0.1698	0.1722
3GPP Rel 8	DC-HSDPA Subtest-1	21.76	22.07	21.95	0.1762	0.1892	0.1841
3GPP Rel 8	DC-HSDPA Subtest-2	21.91	21.98	21.92	0.1824	0.1854	0.1828
3GPP Rel 8	DC-HSDPA Subtest-3	21.37	21.71	21.49	0.1611	0.1742	0.1656
3GPP Rel 8	DC-HSDPA Subtest-4	21.29	21.54	21.30	0.1581	0.1675	0.1585
3GPP Rel 6	HSUPA Subtest-1	21.86	22.18	22.10	0.1803	0.1941	0.1905
3GPP Rel 6	HSUPA Subtest-2	19.83	20.23	20.05	0.1130	0.1239	0.1189
3GPP Rel 6	HSUPA Subtest-3	20.96	21.16	20.89	0.1466	0.1535	0.1442
3GPP Rel 6	HSUPA Subtest-4	19.92	20.07	19.84	0.1153	0.1194	0.1132
3GPP Rel 6	HSUPA Subtest-5	21.84	22.15	21.90	0.1795	0.1928	0.1820



A1. GSM

Peak-to-Average Ratio

Mode	GSM850		Limit: 13dB
Mod.	GPRS class 8	EDGE class 8	Result
Lowest CH	0.20	3.28	PASS
Middle CH	0.12	3.25	
Highest CH	0.12	3.10	
Mode	GSM1900		Limit: 13dB
Mod.	GPRS class 8	EDGE class 8	Result
Lowest CH	0.20	3.42	PASS
Middle CH	0.12	3.48	
Highest CH	0.17	3.51	

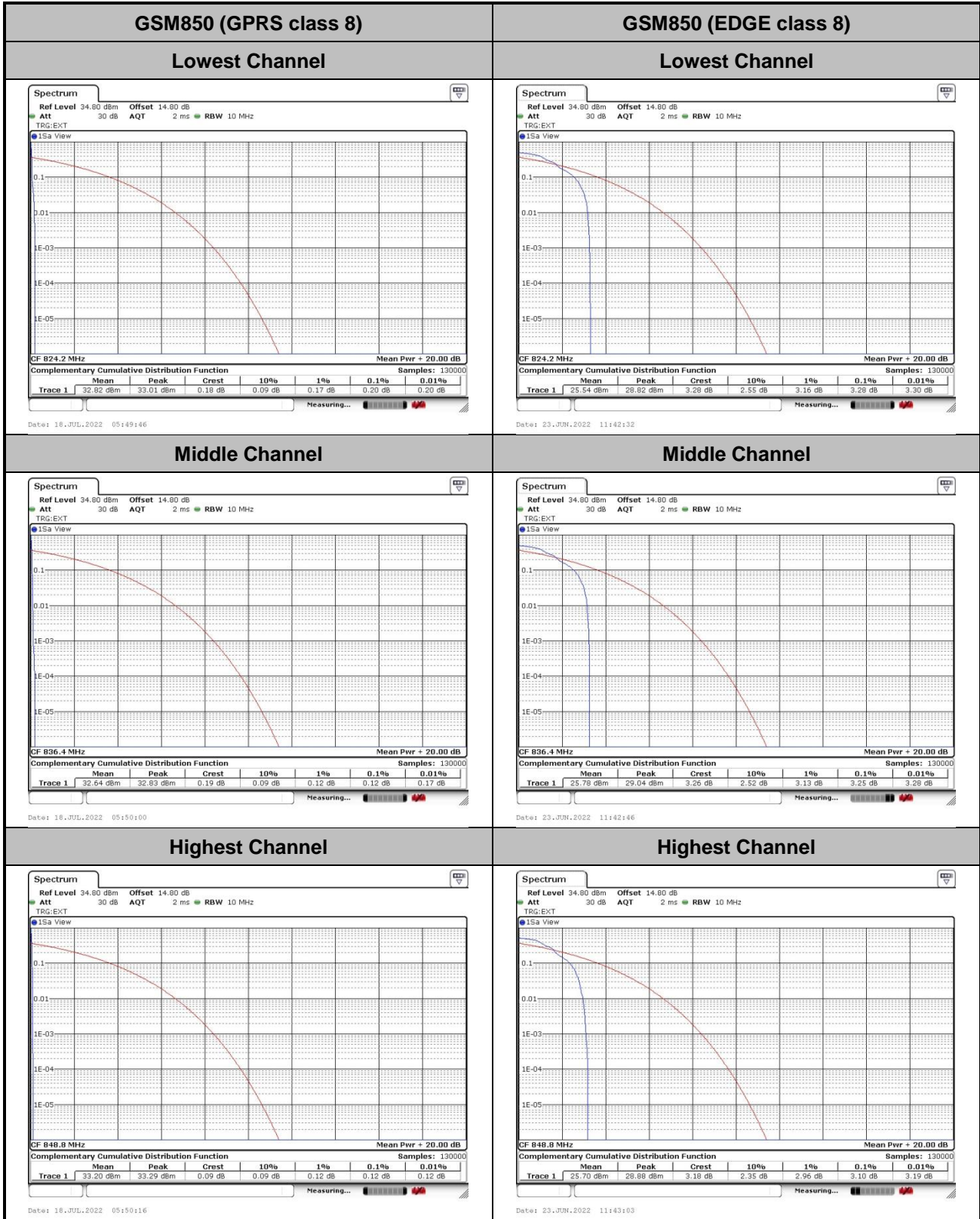

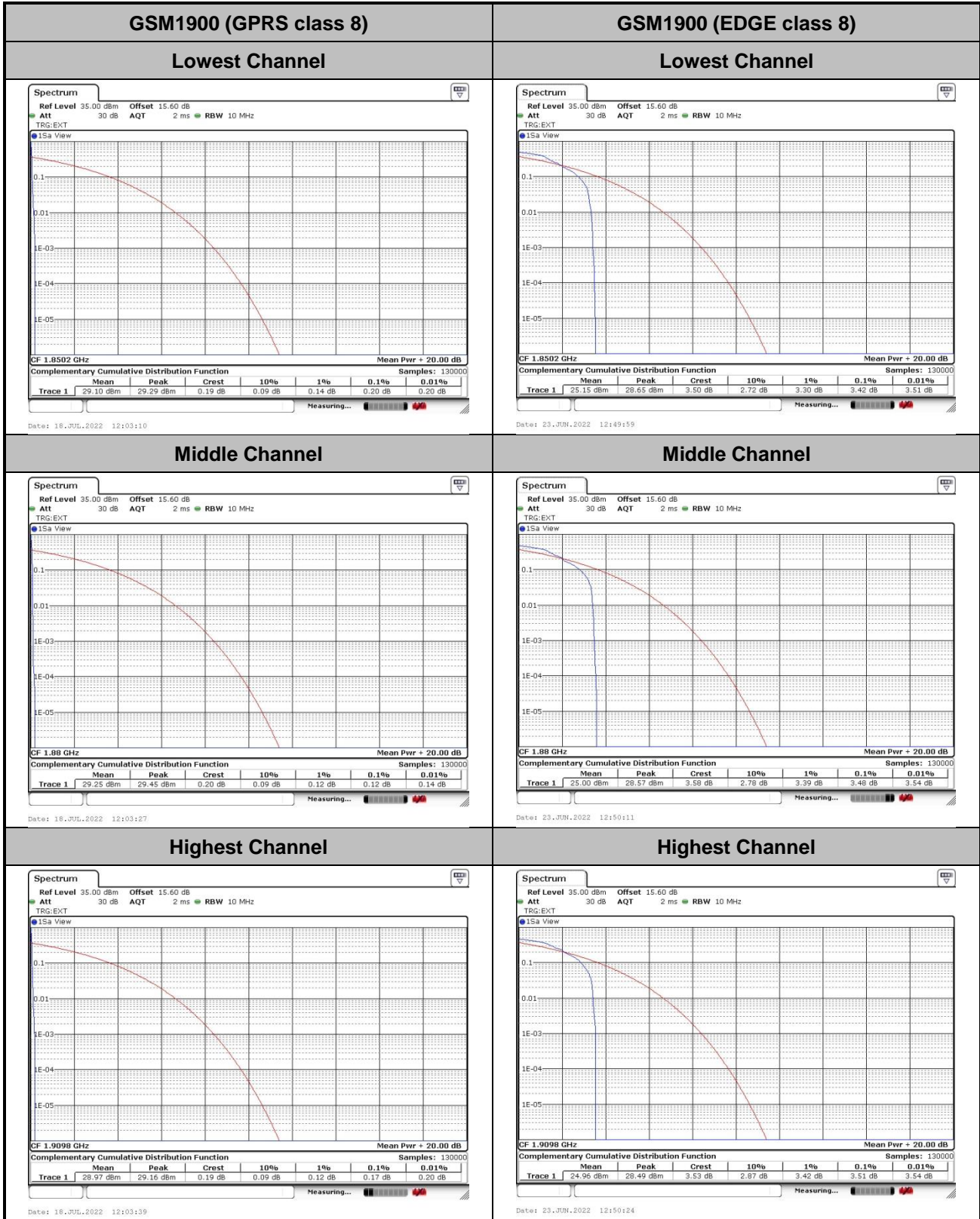



26dB Bandwidth

Mode	GSM850(MHz)	
Mod.	GPRS class 8	EDGE class 8
Lowest CH	0.315	0.295
Middle CH	0.315	0.299
Highest CH	0.316	0.305
Mode	GSM1900(MHz)	
Mod.	GPRS class 8	EDGE class 8
Lowest CH	0.298	0.316
Middle CH	0.290	0.310
Highest CH	0.294	0.315



GSM850 (GPRS class 8)

Lowest Channel



Date: 18_JUL_2022 05:38:09

GSM850 (EDGE class 8)

Lowest Channel



Date: 23_JUN_2022 11:29:27

Middle Channel

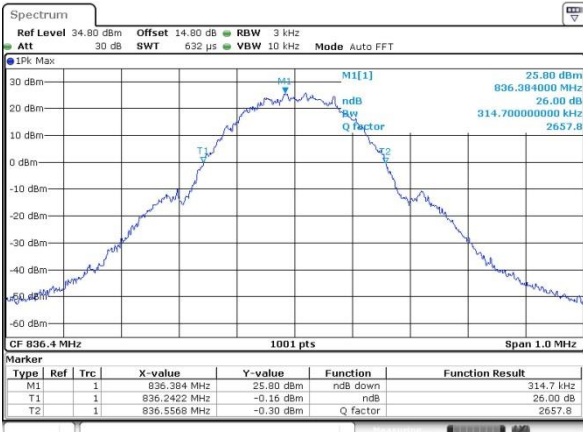

Date: 18_JUL_2022 05:38:42

Middle Channel

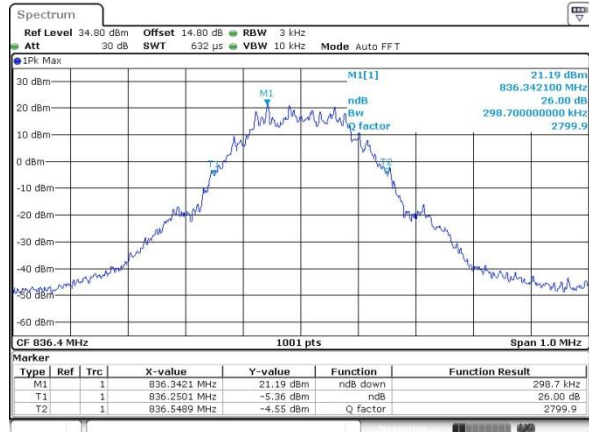

Date: 23_JUN_2022 11:29:53

Highest Channel

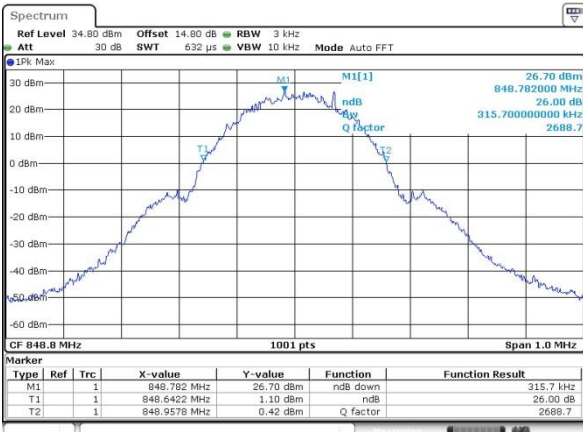

Date: 18_JUL_2022 05:39:26

Highest Channel

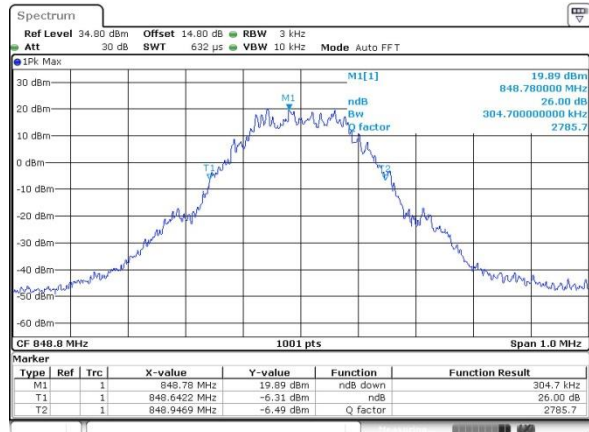

Date: 23_JUN_2022 11:30:34



GSM1900 (GPRS class 8)

Lowest Channel

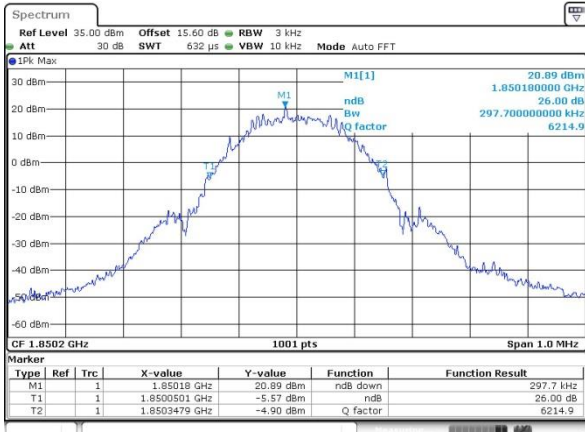

Date: 18_JUL.2022 11:48:55

GSM1900 (EDGE class 8)

Lowest Channel

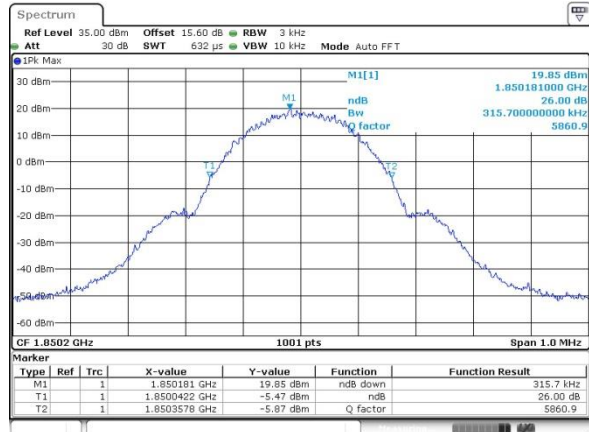

Date: 23_JUN.2022 11:51:48

Middle Channel

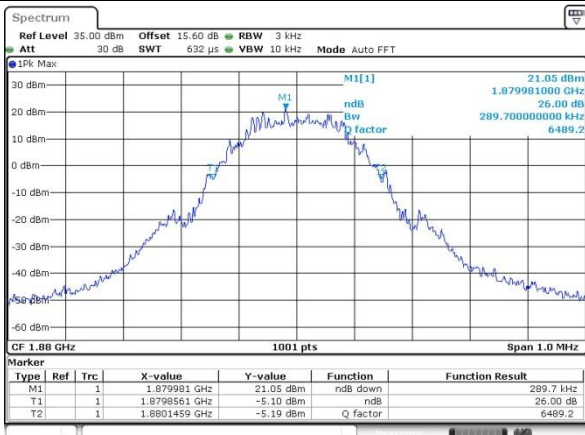

Date: 18_JUL.2022 11:49:19

Middle Channel

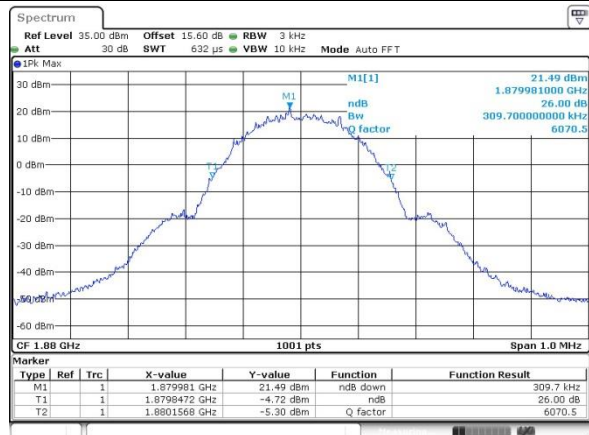

Date: 23_JUN.2022 11:52:19

Highest Channel

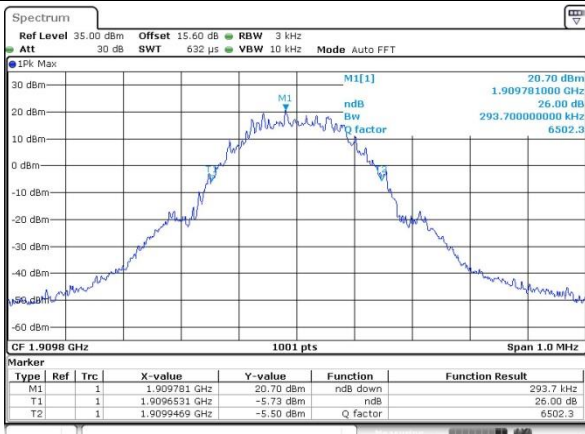

Date: 18_JUL.2022 11:49:42

Highest Channel

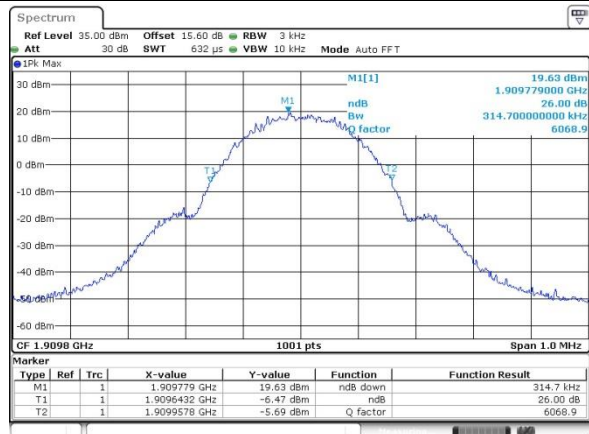

Date: 23_JUN.2022 11:52:42



Occupied Bandwidth

Mode	GSM850(MHz)	
Mod.	GPRS class 8	EDGE class 8
Lowest CH	0.244	0.241
Middle CH	0.245	0.238
Highest CH	0.243	0.238
Mode	GSM1900(MHz)	
Mod.	GPRS class 8	EDGE class 8
Lowest CH	0.241	0.240
Middle CH	0.242	0.239
Highest CH	0.241	0.243

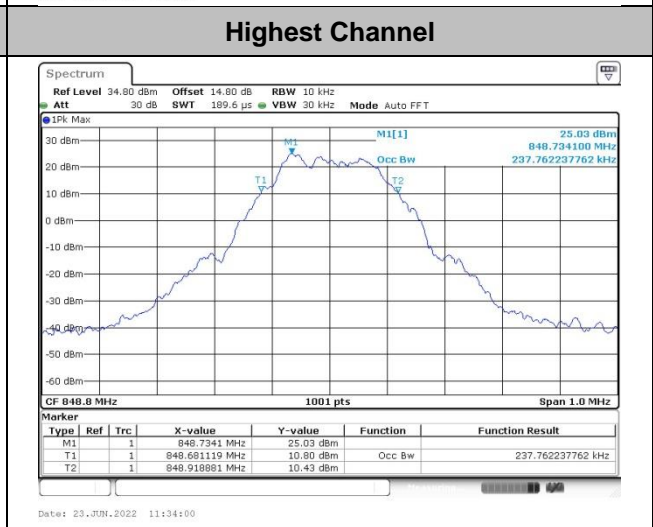
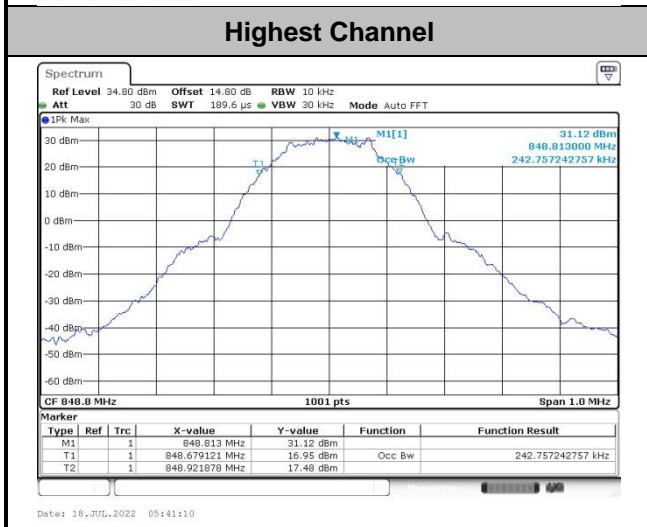
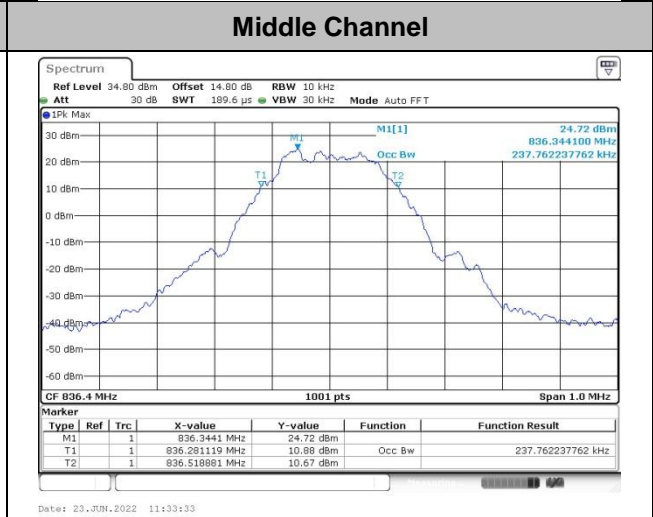
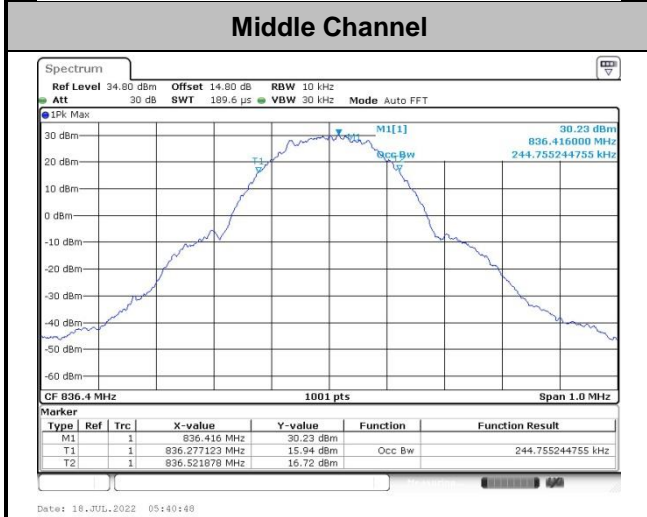
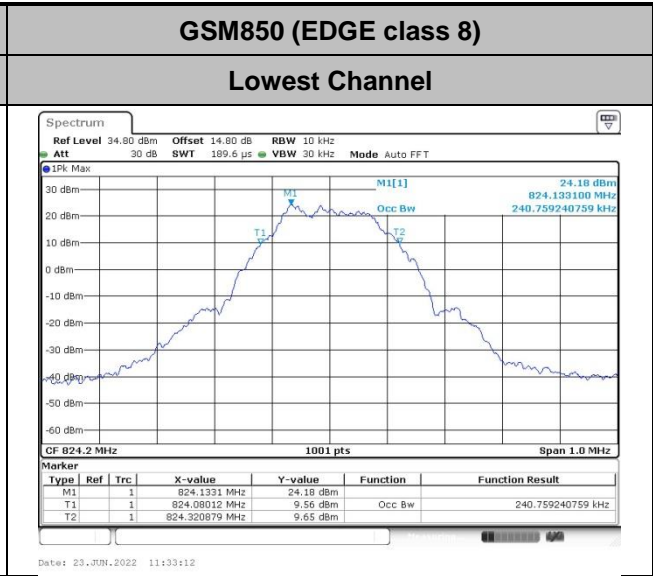
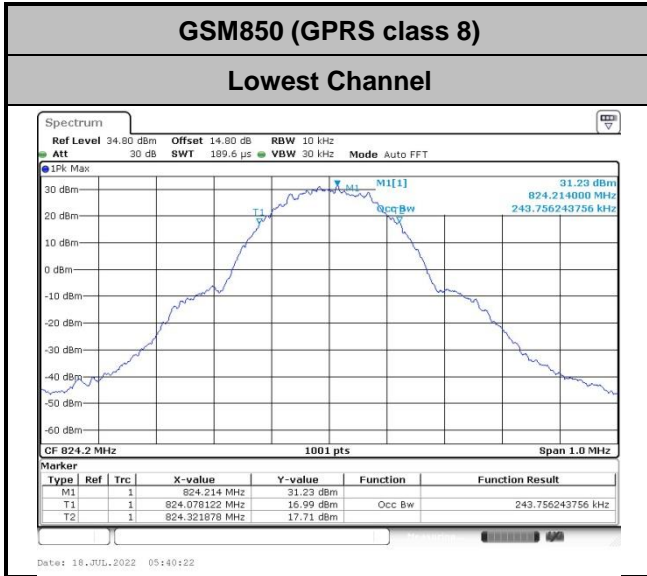



GSM1900 (GPRS class 8)

Lowest Channel

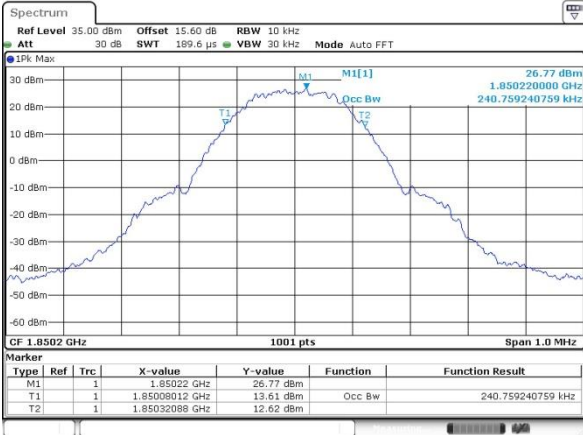

Date: 18_JUL.2022 11:54:06

GSM1900 (EDGE class 8)

Lowest Channel



Date: 23_JUN.2022 12:01:44

Middle Channel

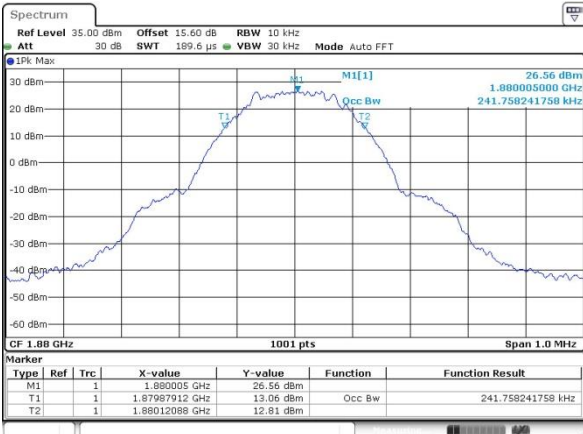

Date: 18_JUL.2022 11:54:28

Middle Channel

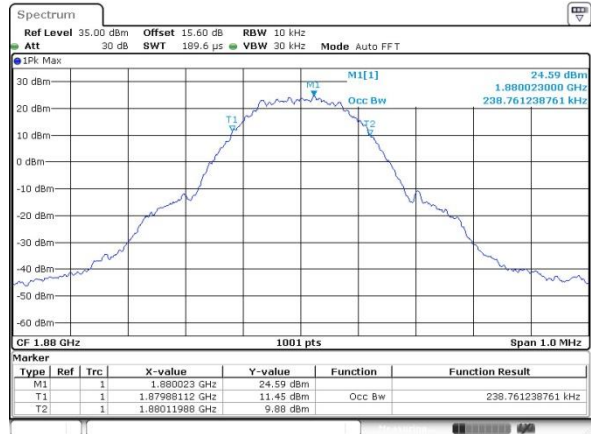

Date: 23_JUN.2022 12:02:05

Highest Channel

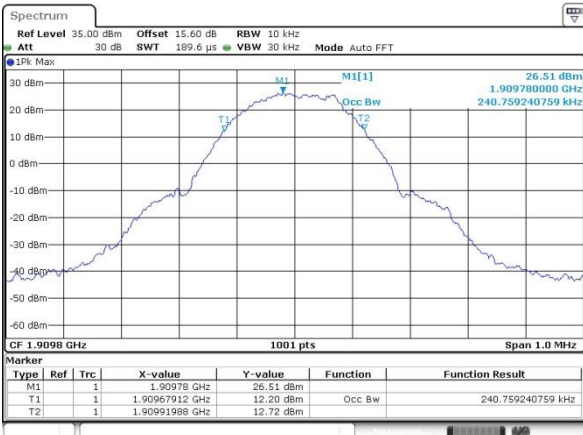

Date: 18_JUL.2022 11:54:52

Highest Channel

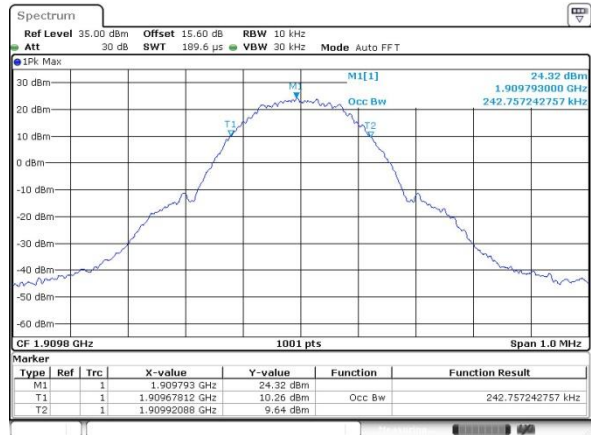

Date: 23_JUN.2022 12:02:26



Conducted Band Edge

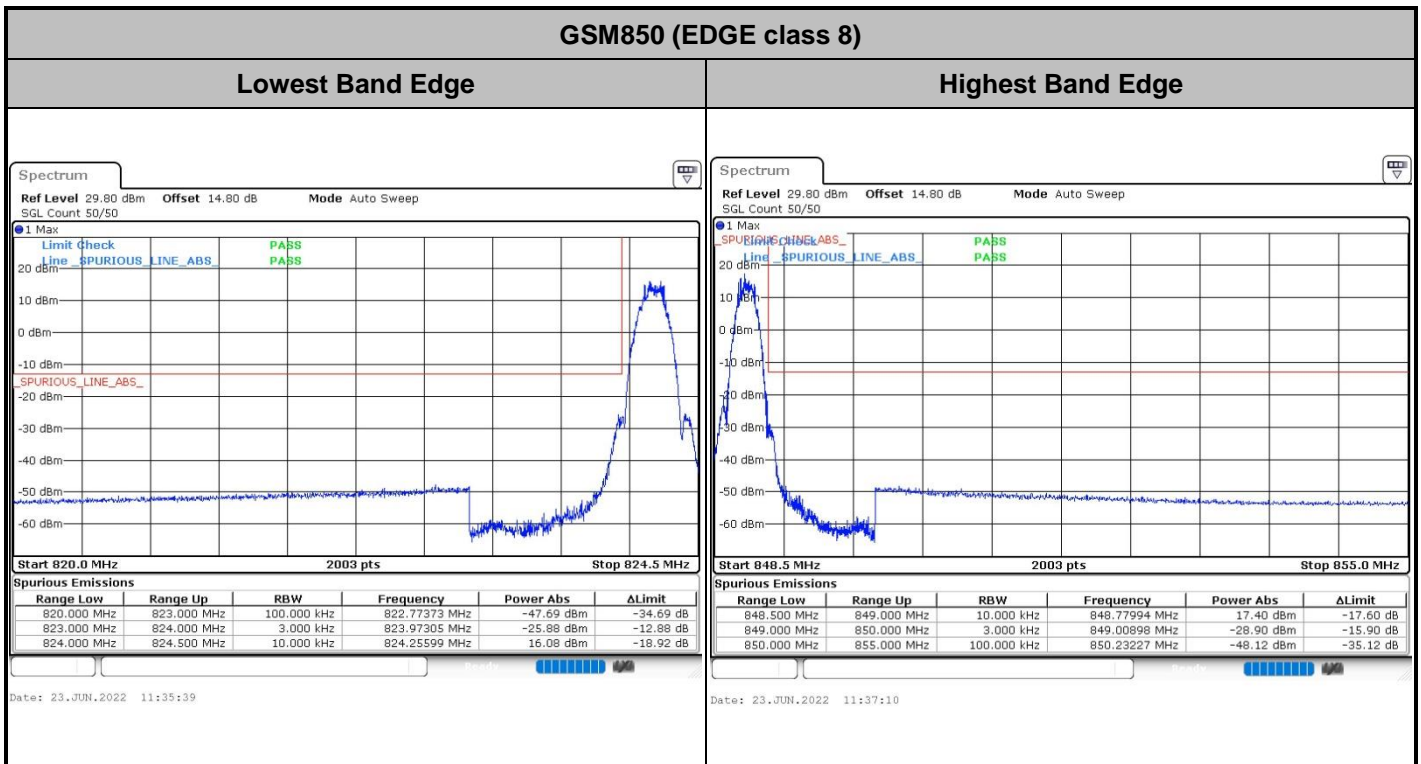
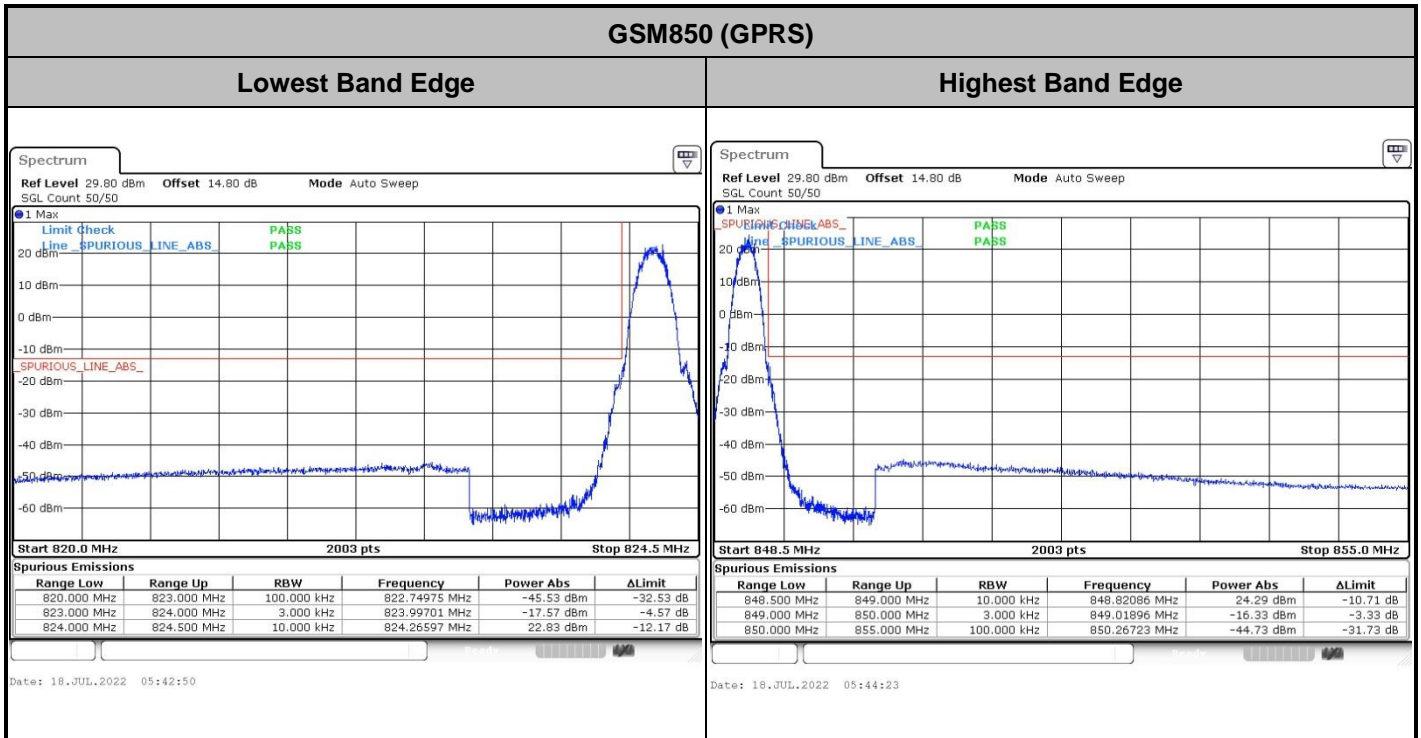



GSM1900 (GPRS)

Lowest Band Edge

Highest Band Edge

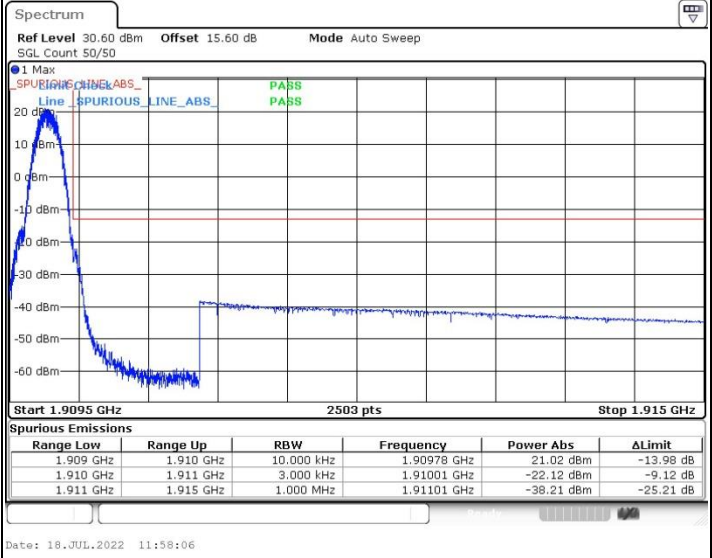
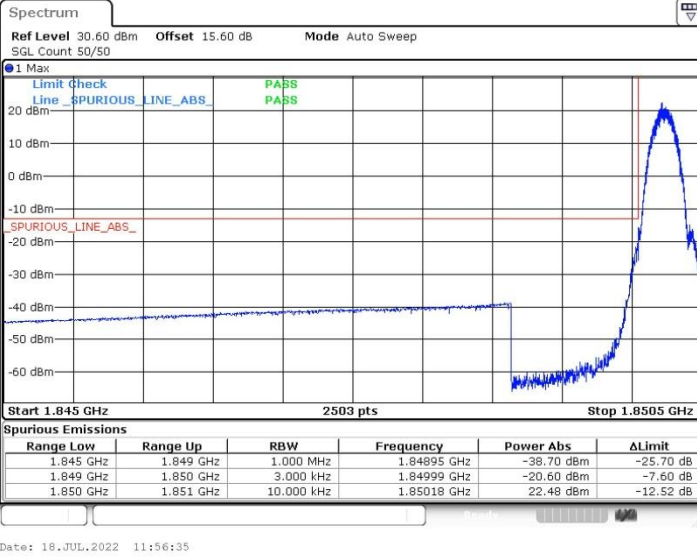

GSM1900 (EDGE class 8)

Lowest Band Edge

Highest Band Edge

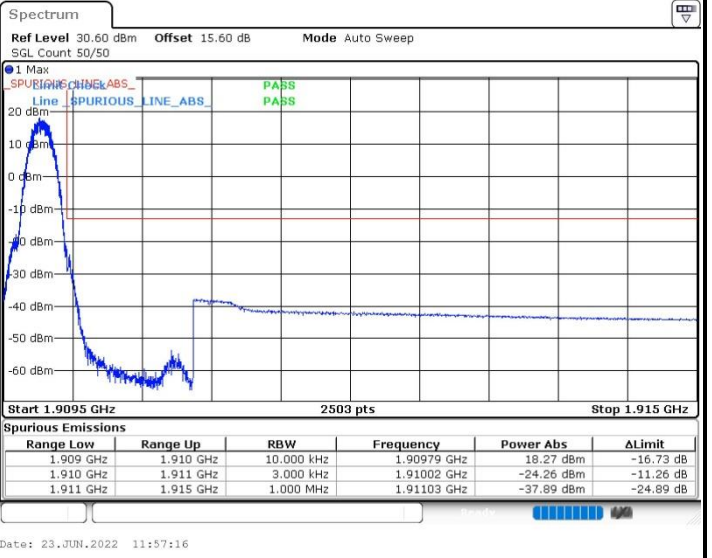
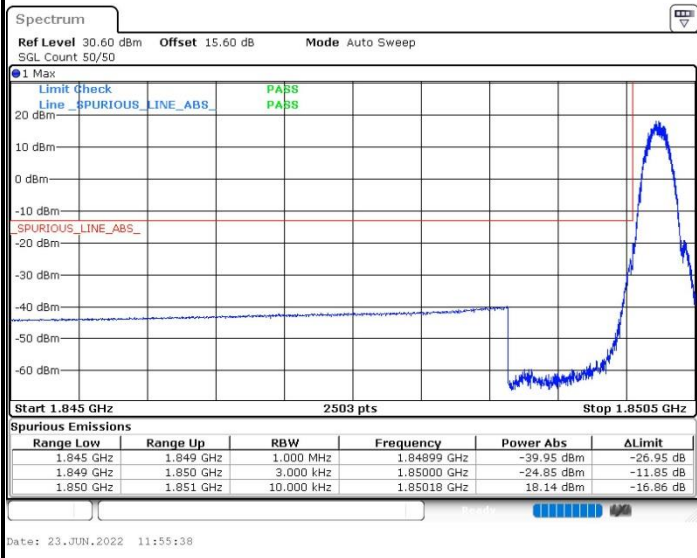



Conducted Spurious Emission

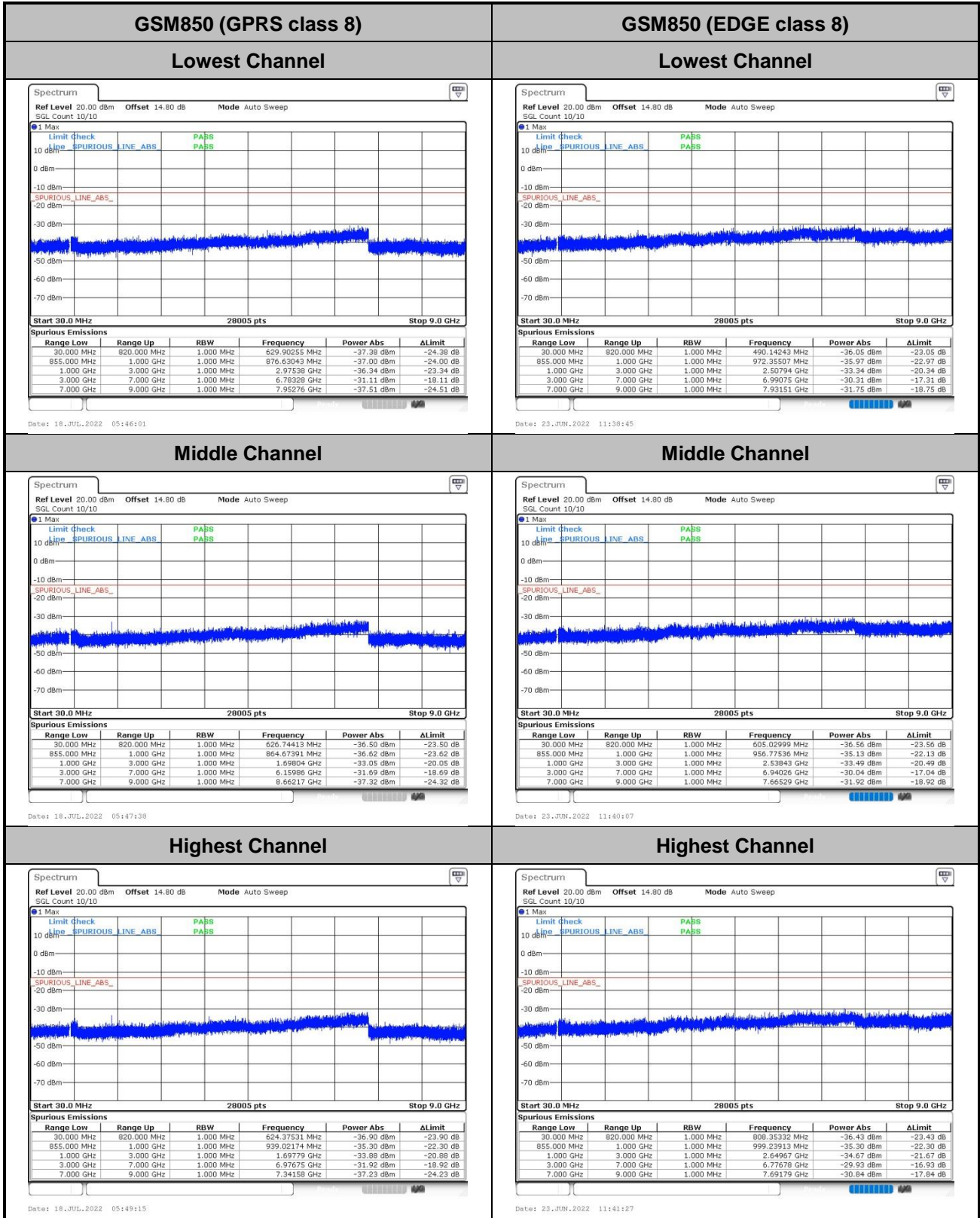

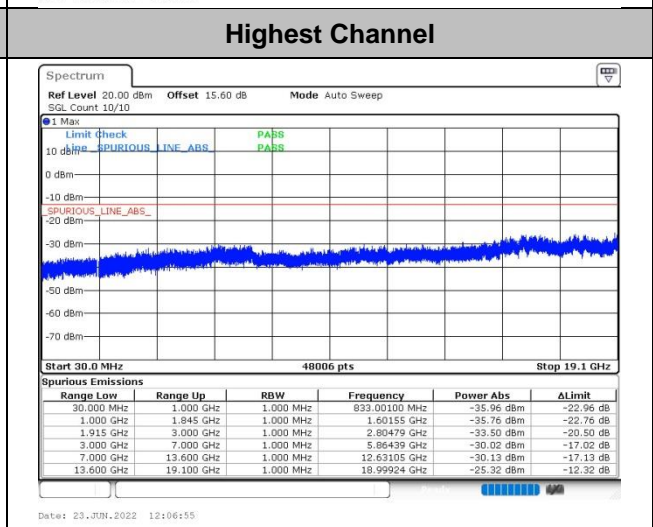
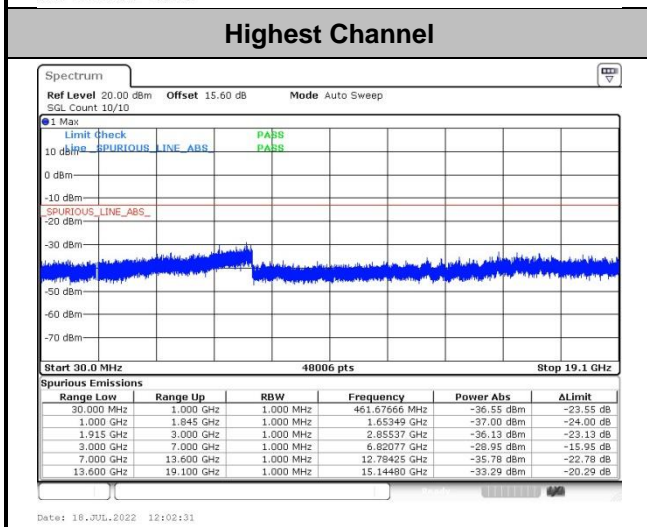
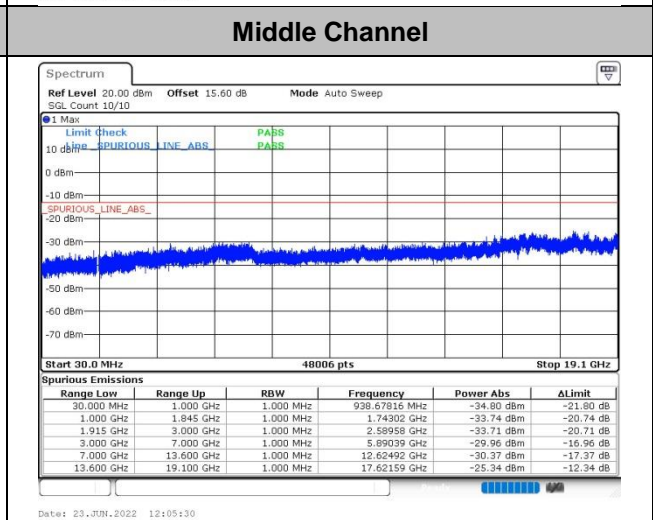
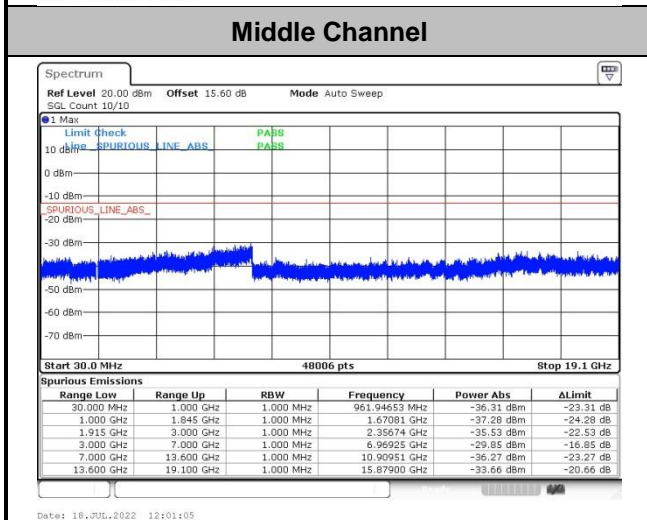
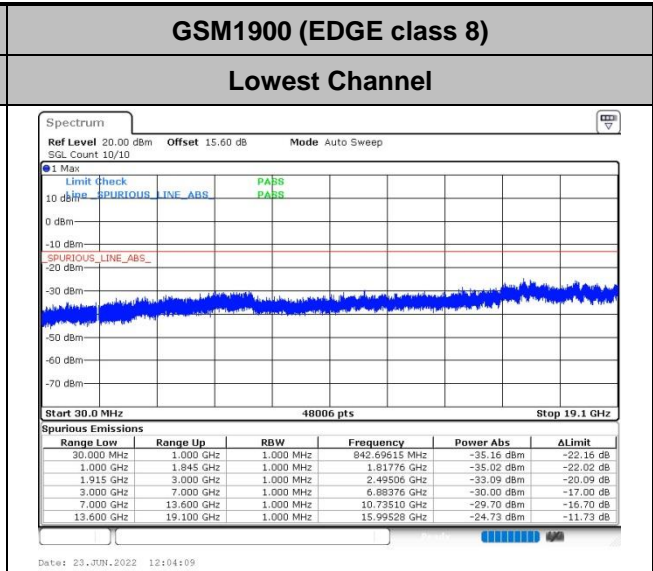
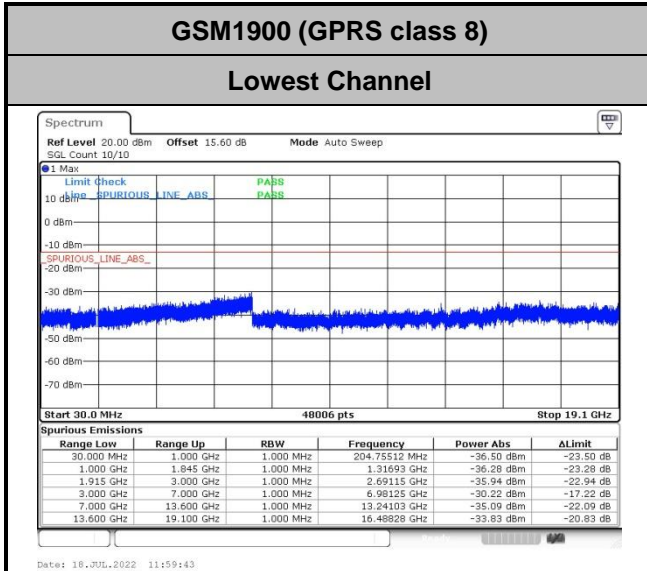



Frequency Stability

Test Conditions	Middle Channel	GSM850 (GPRS class 8)	GSM850 (EDGE class 8)	Limit 2.5ppm
Temperature (°C)	Voltage (Volt)	Deviation (ppm)		Result
50	Normal Voltage	0.0042	0.0058	PASS
40	Normal Voltage	0.0517	0.0147	
30	Normal Voltage	0.0099	0.0562	
20(Ref.)	Normal Voltage	0.0000	0.0000	
10	Normal Voltage	0.0563	0.0428	
0	Normal Voltage	0.0182	0.0536	
-10	Normal Voltage	0.0059	0.0447	
-20	Normal Voltage	0.0139	0.0144	
-30	Normal Voltage	0.0174	0.0458	
20	Maximum Voltage	0.0455	0.0556	
20	Normal Voltage	0.0169	0.0139	
20	Battery End Point	0.0328	0.0238	

Test Conditions	Middle Channel	GSM1900 (GPRS class 8)	GSM1900 (EDGE class 8)	Limit Note 2.
Temperature (°C)	Voltage (Volt)	Deviation (ppm)		Result
50	Normal Voltage	0.0044	0.0002	PASS
40	Normal Voltage	0.0058	0.0044	
30	Normal Voltage	0.0069	0.0076	
20(Ref.)	Normal Voltage	0.0000	0.0000	
10	Normal Voltage	0.0164	0.0269	
0	Normal Voltage	0.0047	0.0162	
-10	Normal Voltage	0.0128	0.0033	
-20	Normal Voltage	0.0218	0.0039	
-30	Normal Voltage	0.0003	0.0274	
20	Maximum Voltage	0.0047	0.0182	
20	Normal Voltage	0.0044	0.0091	
20	Battery End Point	0.0169	0.0014	



Note:

1. Normal Voltage = 3.87V ; Battery End Point (BEP) =3.55V. ; Maximum Voltage =4.45V
2. The frequency fundamental emissions stay within the authorized frequency block based on the frequency deviation measured is small.



A2. WCDMA

Peak-to-Average Ratio

Mode	WCDMA Band IV	WCDMA Band II	WCDMA Band V	Limit: 13dB
Mod.	RMC 12.2Kbps	RMC 12.2Kbps	RMC 12.2Kbps	Result
Lowest CH	3.36	3.59	4.49	PASS
Middle CH	3.42	3.77	4.26	
Highest CH	4.32	3.42	4.35	

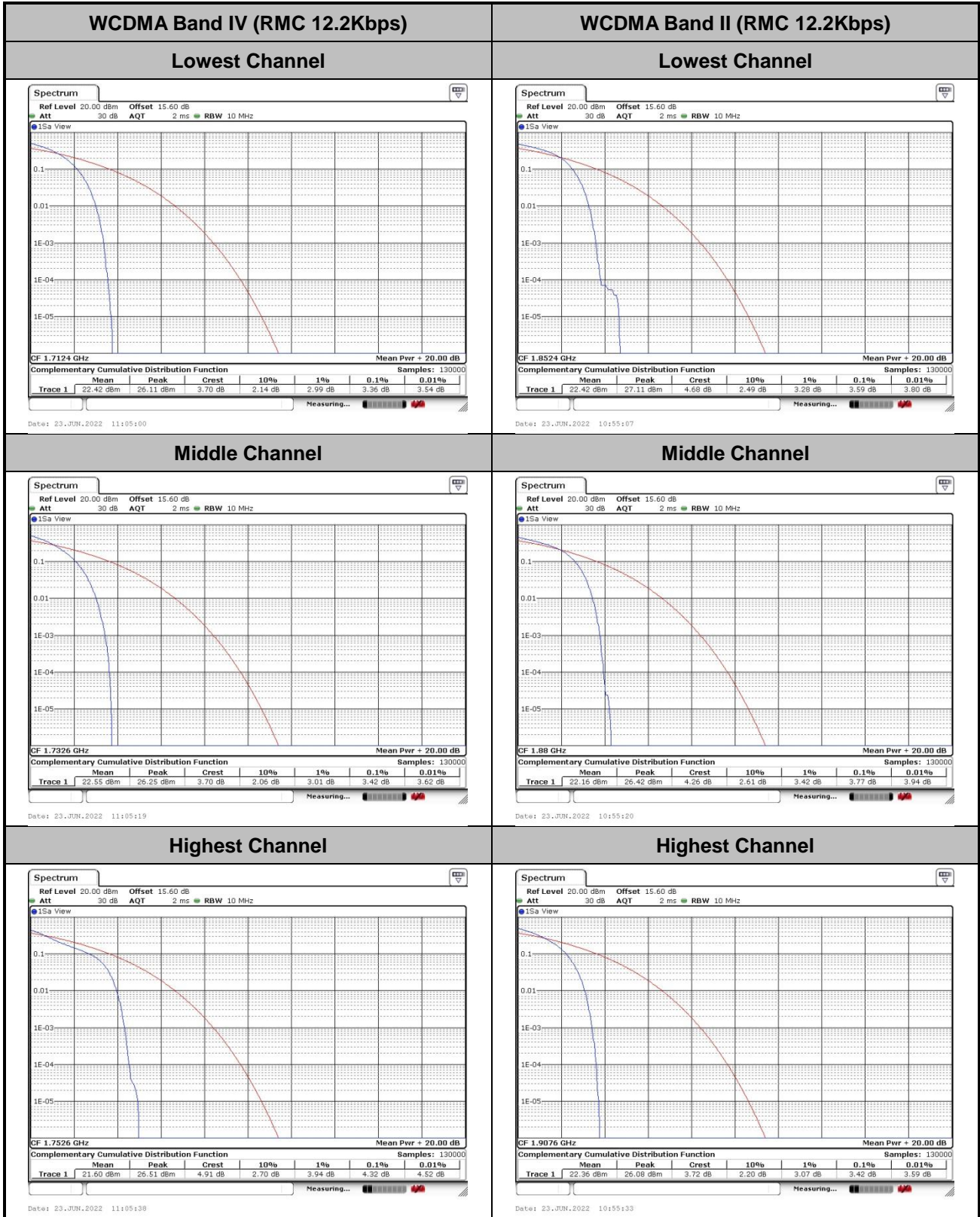

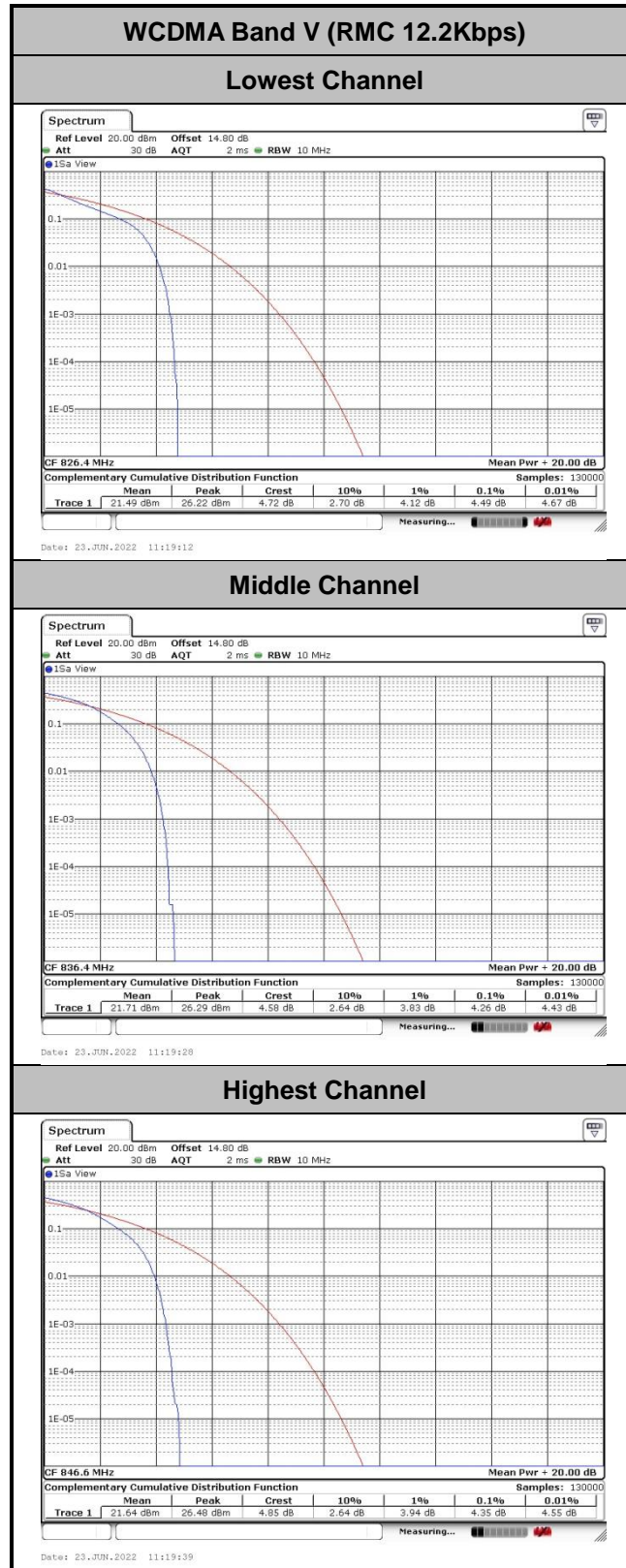



26dB Bandwidth

Mode	WCDMA Band IV(MHz)	WCDMA Band II(MHz)	WCDMA Band V(MHz)
Mod.	RMC 12.2Kbps	RMC 12.2Kbps	RMC 12.2Kbps
Lowest CH	4.725	4.715	4.715
Middle CH	4.725	4.715	4.715
Highest CH	4.725	4.725	4.705