

System Check_Body_835MHz_120525

DUT: D835V2-SN:499

Communication System: CW; Frequency: 835 MHz; Duty Cycle: 1:1

Medium: MSL_850_120525 Medium parameters used: $f = 835 \text{ MHz}$; $\sigma = 0.963 \text{ mho/m}$; $\epsilon_r = 54.5$; $\rho = 1000 \text{ kg/m}^3$

Ambient Temperature : 22.5 °C ; Liquid Temperature : 21.5 °C

DASY4 Configuration:

- Probe: ET3DV6R - SN1788; ConvF(5.75, 5.75, 5.75); Calibrated: 2012/1/26
- Sensor-Surface: 4mm (Mechanical Surface Detection)
- Electronics: DAE4 Sn778; Calibrated: 2011/11/22
- Phantom: ELI 4.0_Front; Type: QDOVA001BB; Serial: 1026
- Measurement SW: DASY4, V4.7 Build 80; Postprocessing SW: SEMCAD, V1.8 Build 186

Pin=250mW/Area Scan (61x61x1): Measurement grid: dx=15mm, dy=15mm

Maximum value of SAR (interpolated) = 2.63 mW/g

Pin=250mW/Zoom Scan (7x7x7)/Cube 0: Measurement grid: dx=5mm, dy=5mm, dz=5mm

Reference Value = 53.8 V/m; Power Drift = -0.116 dB

Peak SAR (extrapolated) = 3.76 W/kg

SAR(1 g) = 2.42 mW/g; SAR(10 g) = 1.52 mW/g

Maximum value of SAR (measured) = 2.64 mW/g

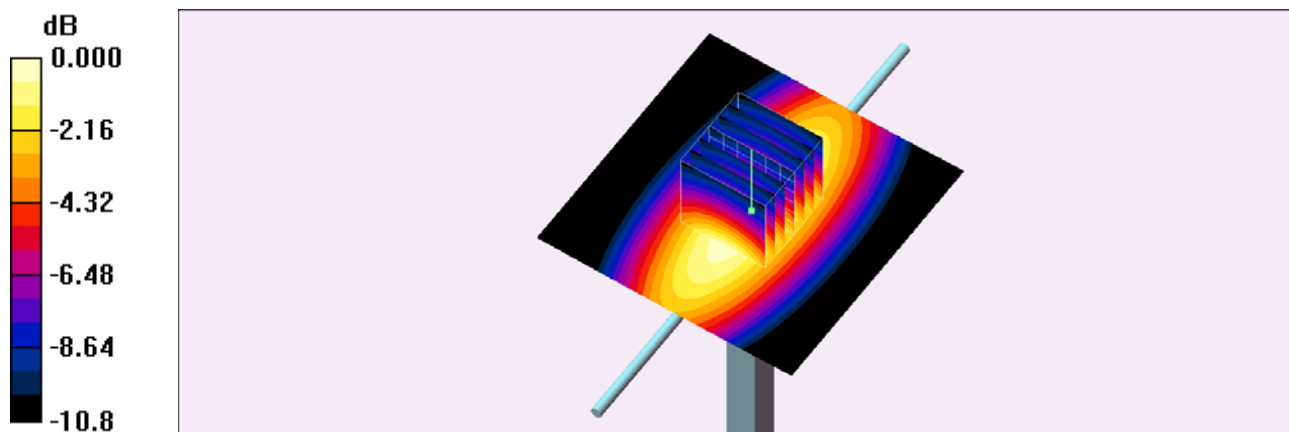

0 dB = 2.64mW/g

System Check_Body_1750MHz_120526

DUT: D1750V2-SN:1023

Communication System: CW; Frequency: 1750 MHz; Duty Cycle: 1:1

Medium: MSL_1750_120526 Medium parameters used: $f = 1750$ MHz; $\sigma = 1.55$ mho/m; $\epsilon_r = 51.7$; $\rho = 1000$ kg/m³

Ambient Temperature : 22.6 °C ; Liquid Temperature : 21.6 °C

DASY4 Configuration:

- Probe: ET3DV6R - SN1788; ConvF(4.29, 4.29, 4.29); Calibrated: 2012/1/26
- Sensor-Surface: 4mm (Mechanical Surface Detection)
- Electronics: DAE4 Sn778; Calibrated: 2011/11/22
- Phantom: ELI 4.0_Front; Type: QDOVA001BB; Serial: 1026
- Measurement SW: DASY4, V4.7 Build 80; Postprocessing SW: SEMCAD, V1.8 Build 186

Pin=250mW/Area Scan (61x61x1): Measurement grid: dx=15mm, dy=15mm

Maximum value of SAR (interpolated) = 10.6 mW/g

Pin=250mW/Zoom Scan (7x7x7)/Cube 0: Measurement grid: dx=5mm, dy=5mm, dz=5mm

Reference Value = 86.3 V/m; Power Drift = 0.024 dB

Peak SAR (extrapolated) = 13.3 W/kg

SAR(1 g) = 8.69 mW/g; SAR(10 g) = 4.77 mW/g

Maximum value of SAR (measured) = 9.95 mW/g

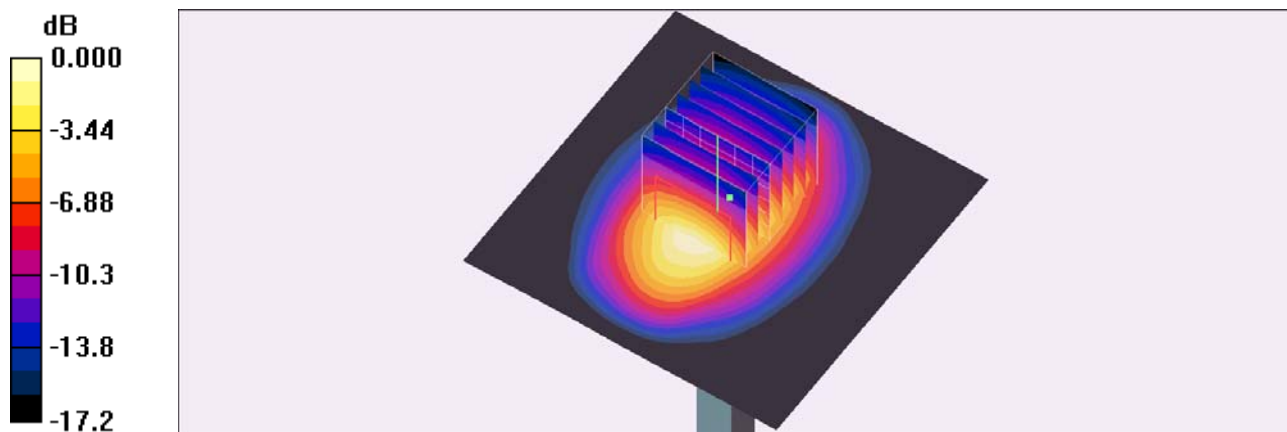

0 dB = 9.95mW/g

System Check_Body_1900MHz_120525

DUT: D1900V2-SN:5d041

Communication System: CW; Frequency: 1900 MHz; Duty Cycle: 1:1

Medium: MSL_1900_120525 Medium parameters used: $f = 1900$ MHz; $\sigma = 1.52$ mho/m; $\epsilon_r = 54.6$; $\rho = 1000$ kg/m³

Ambient Temperature : 22.5 °C ; Liquid Temperature : 21.5 °C

DASY4 Configuration:

- Probe: ET3DV6R - SN1788; ConvF(4.06, 4.06, 4.06); Calibrated: 2012/1/26
- Sensor-Surface: 4mm (Mechanical Surface Detection)
- Electronics: DAE4 Sn778; Calibrated: 2011/11/22
- Phantom: ELI 4.0_Front; Type: QDOVA001BB; Serial: 1026
- Measurement SW: DASY4, V4.7 Build 80; Postprocessing SW: SEMCAD, V1.8 Build 186

Pin=250mW/Area Scan (61x61x1): Measurement grid: dx=15mm, dy=15mm

Maximum value of SAR (interpolated) = 11.3 mW/g

Pin=250mW/Zoom Scan (7x7x7)/Cube 0: Measurement grid: dx=5mm, dy=5mm, dz=5mm

Reference Value = 90.6 V/m; Power Drift = 0.086 dB

Peak SAR (extrapolated) = 15.8 W/kg

SAR(1 g) = 9.57 mW/g; SAR(10 g) = 5.01 mW/g

Maximum value of SAR (measured) = 10.9 mW/g

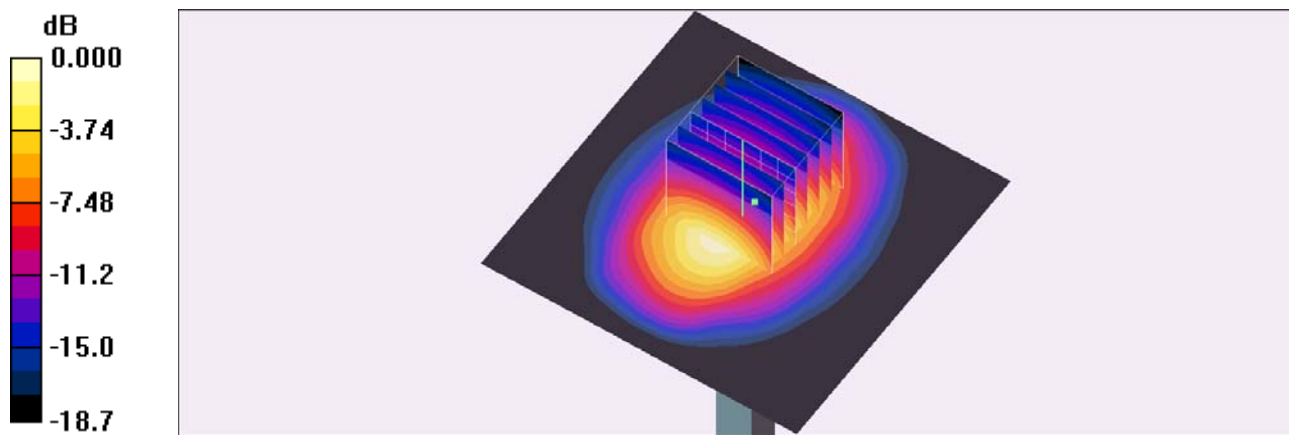

0 dB = 10.9mW/g

System Check_Body_2450MHz_120603

DUT: D2450V2-SN:736

Communication System: CW; Frequency: 2450 MHz; Duty Cycle: 1:1

Medium: MSL_2450_120603 Medium parameters used: $f = 2450$ MHz; $\sigma = 1.97$ mho/m; $\epsilon_r = 52.7$; $\rho = 1000$ kg/m³

Ambient Temperature : 22.6 °C; Liquid Temperature : 21.6 °C

DASY5 Configuration:

- Probe: EX3DV4 - SN3792; ConvF(6.67, 6.67, 6.67); Calibrated: 2011/6/20
- Sensor-Surface: 4mm (Mechanical Surface Detection)
- Electronics: DAE3 Sn495; Calibrated: 2012/4/23
- Phantom: ELI 4.0; Type: QDOVA001BA; Serial: 1029
- Software: DASY5 Version; SEMCAD X Version 13.4 Build 45

Pin=250mW/Area Scan (91x91x1): Measurement grid: dx=10mm, dy=10mm

Maximum value of SAR (interpolated) = 15.8 mW/g

Pin=250mW/Zoom Scan (7x7x7)/Cube 0: Measurement grid: dx=5mm, dy=5mm, dz=5mm

Reference Value = 87.1 V/m; Power Drift = 0.085 dB

Peak SAR (extrapolated) = 30.5 W/kg

SAR(1 g) = 13.9 mW/g; SAR(10 g) = 6.62 mW/g

Maximum value of SAR (measured) = 15.5 mW/g

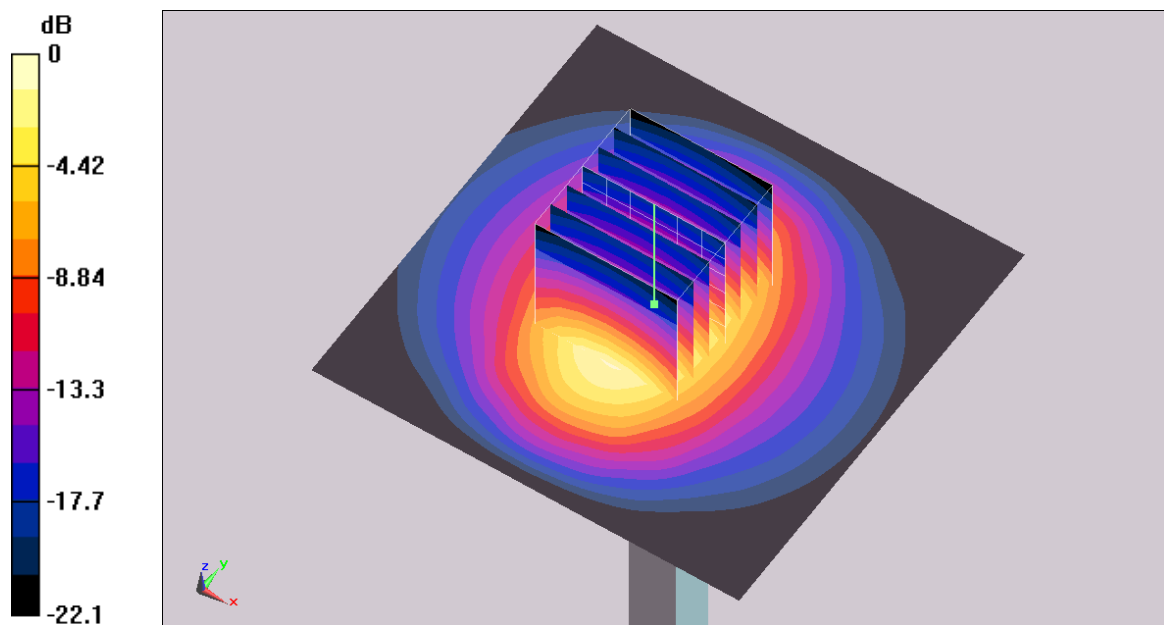

0 dB = 15.5mW/g

System Check_Body_5200MHz_120605

DUT: D5GHzV2-SN:1006

Communication System: 0; Frequency: 5200 MHz; Duty Cycle: 1:1

Medium: MSL_5G_120605 Medium parameters used: $f = 5200 \text{ MHz}$; $\sigma = 5.162 \text{ mho/m}$; $\epsilon_r = 48.492$;

$\rho = 1000 \text{ kg/m}^3$

Ambient Temperature : $22.5 \text{ }^\circ\text{C}$; Liquid Temperature : $21.5 \text{ }^\circ\text{C}$

DASY5 Configuration:

- Probe: EX3DV4 - SN3819; ConvF(4.48, 4.48, 4.48); Calibrated: 2011/11/16;
- Sensor-Surface: 2.5mm (Mechanical Surface Detection)
- Electronics: DAE4 Sn1279; Calibrated: 2012/5/3
- Phantom: ELI v5.0; Type: QDOVA002AA; Serial: TP1127
- Measurement SW: DASY52, Version 52.8 (1); SEMCAD X Version 14.6.5 (6469)

Pin=250mW/Area Scan (91x91x1): Measurement grid: dx=10mm, dy=10mm

Maximum value of SAR (interpolated) = 42.7 mW/g

Pin=250mW/Zoom Scan (8x8x8)/Cube 0: Measurement grid: dx=4.3mm, dy=4.3mm, dz=3mm

Reference Value = 99.107 V/m ; Power Drift = -0.16 dB

Peak SAR (extrapolated) = 59.921 mW/g

SAR(1 g) = 18.6 mW/g ; SAR(10 g) = 5.44 mW/g

Maximum value of SAR (measured) = 31.3 mW/g

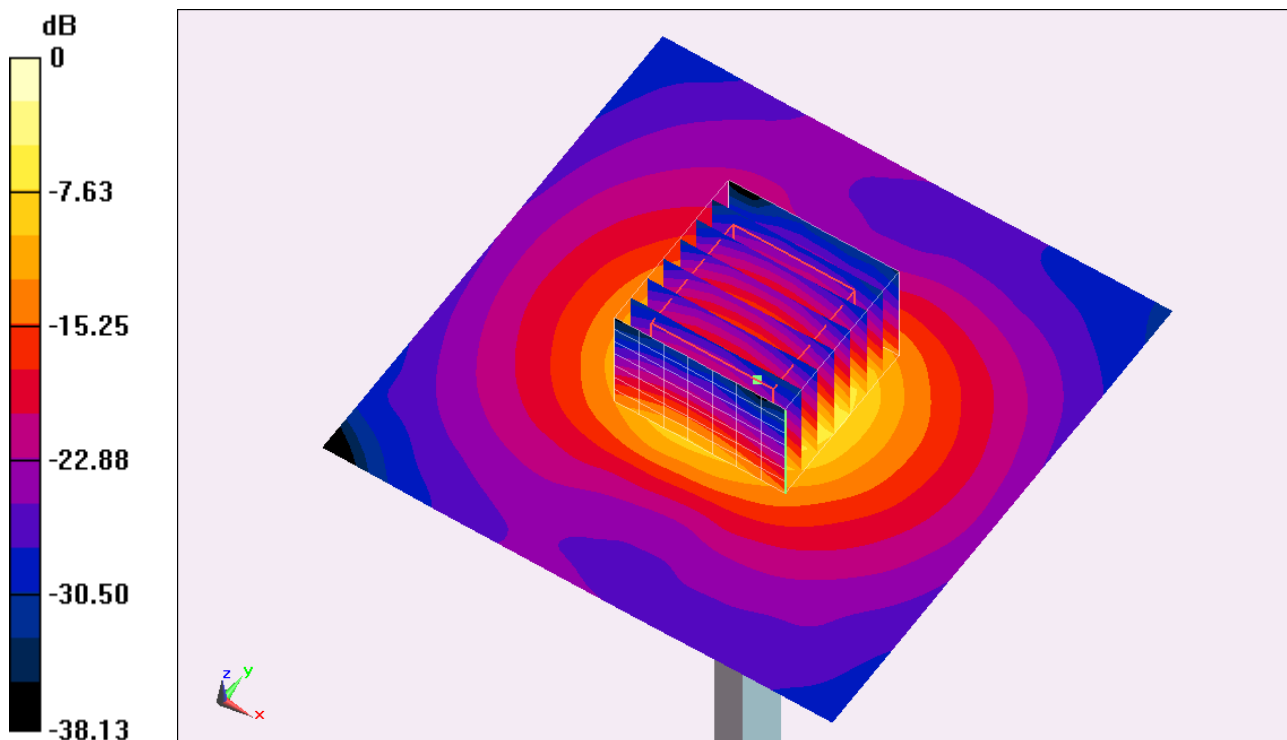

0 dB = $31.3 \text{ mW/g} = 29.91 \text{ dB mW/g}$

System Check_Body_5500MHz_120602

DUT: D5GHzV2-SN:1006

Communication System: CW; Frequency: 5500 MHz; Duty Cycle: 1:1

Medium: MSL_5G_120602 Medium parameters used: $f = 5500$ MHz; $\sigma = 5.71$ mho/m; $\epsilon_r = 47$; $\rho = 1000$ kg/m³

Ambient Temperature : 22.4 °C ; Liquid Temperature : 21.4 °C

DASY5 Configuration:

- Probe: EX3DV4 - SN3792; ConvF(3.76, 3.76, 3.76); Calibrated: 2011/6/20
- Sensor-Surface: 2.5mm (Mechanical Surface Detection)
- Electronics: DAE3 Sn495; Calibrated: 2012/4/23
- Phantom: ELI 4.0_Front; Type: QD 0VA 002 AA; Serial: TP-1131
- Software: DASY5 Version; SEMCAD X Version 13.4 Build 45

Pin=250mW/Area Scan (91x91x1): Measurement grid: dx=10mm, dy=10mm

Maximum value of SAR (interpolated) = 35.5 mW/g

Pin=250mW/Zoom Scan (8x8x8)/Cube 0: Measurement grid: dx=4.3mm, dy=4.3mm, dz=3mm

Reference Value = 82.7 V/m; Power Drift = 0.144 dB

Peak SAR (extrapolated) = 76.5 W/kg

SAR(1 g) = 20.5 mW/g; SAR(10 g) = 5.71 mW/g

Maximum value of SAR (measured) = 35.1 mW/g

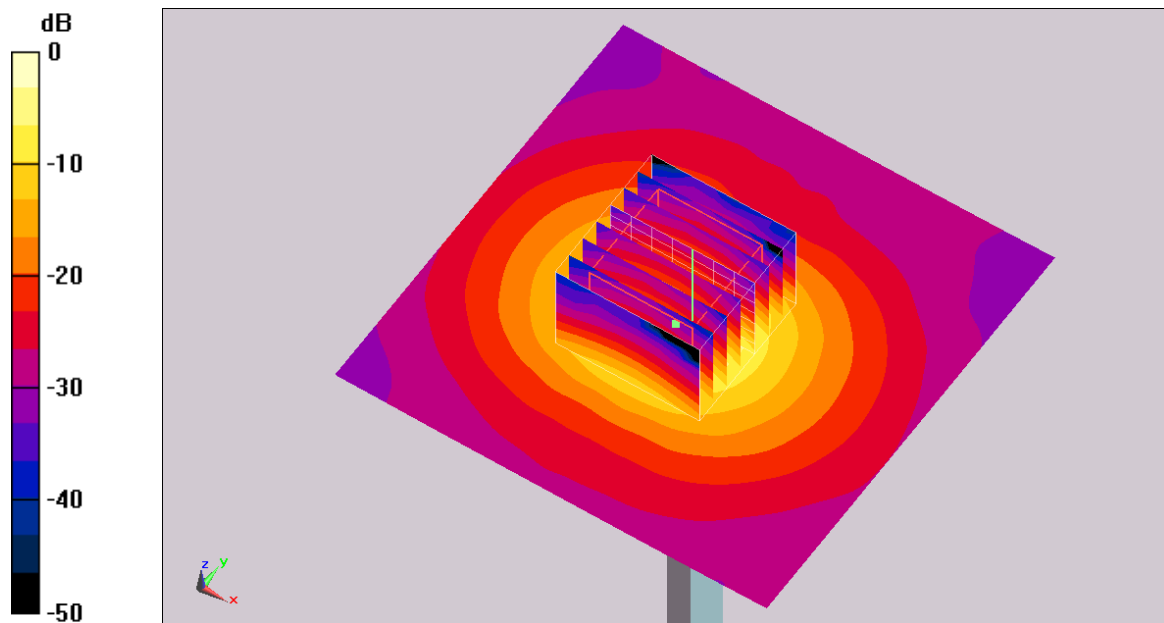

0 dB = 35.1mW/g

System Check_Body_5800MHz_120605

DUT: D5GHzV2-SN:1006

Communication System: CW; Frequency: 5800 MHz; Duty Cycle: 1:1

Medium: MSL_5G_120605 Medium parameters used: $f = 5800 \text{ MHz}$; $\sigma = 5.976 \text{ mho/m}$; $\epsilon_r = 47.158$;

$\rho = 1000 \text{ kg/m}^3$

Ambient Temperature : 22.5 °C ; Liquid Temperature : 21.5 °C

DASY5 Configuration:

- Probe: EX3DV4 - SN3819; ConvF(4.02, 4.02, 4.02); Calibrated: 2011/11/16;
- Sensor-Surface: 2.5mm (Mechanical Surface Detection)
- Electronics: DAE4 Sn1279; Calibrated: 2012/5/3
- Phantom: ELI v5.0; Type: QDOVA002AA; Serial: TP1127
- Measurement SW: DASY52, Version 52.8 (1); SEMCAD X Version 14.6.5 (6469)

Pin=250mW/Area Scan (91x91x1): Measurement grid: dx=10mm, dy=10mm

Maximum value of SAR (interpolated) = 32.3 mW/g

Pin=250mW/Zoom Scan (8x8x8)/Cube 0: Measurement grid: dx=4.3mm, dy=4.3mm, dz=3mm

Reference Value = 79.086 V/m; Power Drift = 0.05 dB

Peak SAR (extrapolated) = 54.348 mW/g

SAR(1 g) = 17.9 mW/g; SAR(10 g) = 5.19 mW/g

Maximum value of SAR (measured) = 29.8 mW/g

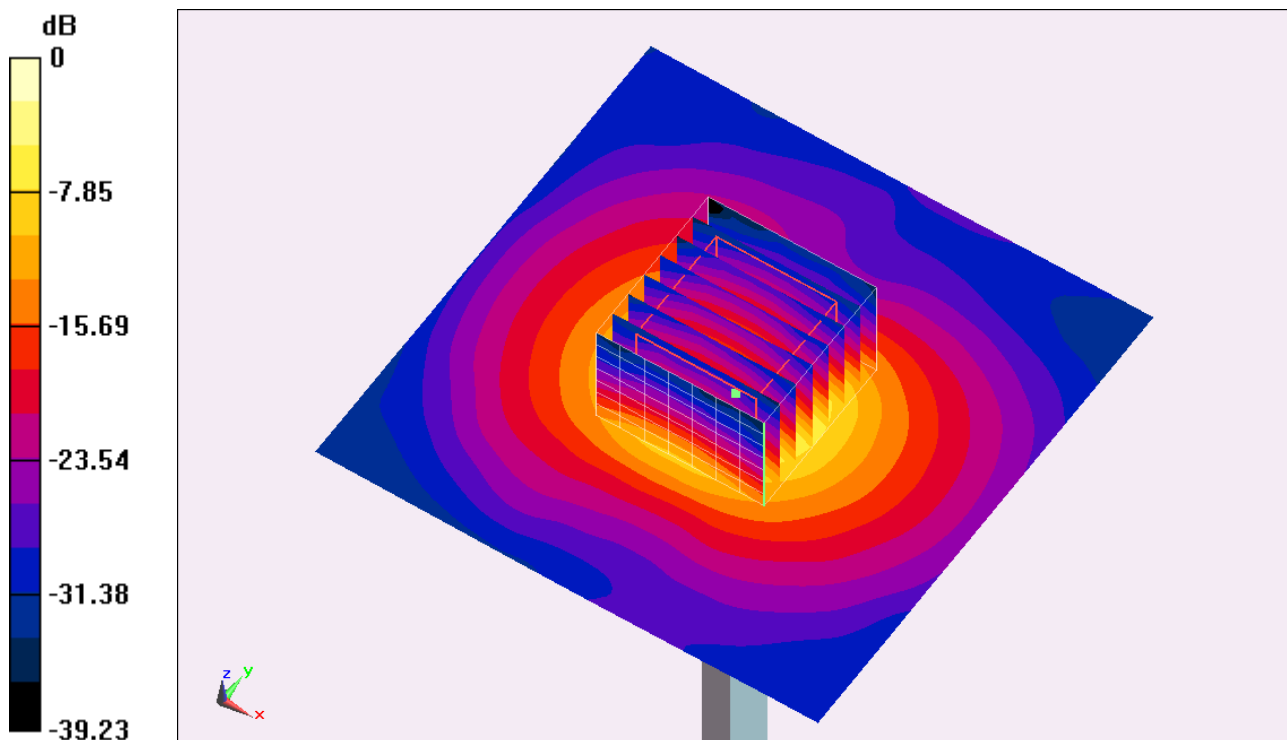

0 dB = 29.8 mW/g = 29.48 dB mW/g