



FCC RADIO TEST REPORT

FCC ID : UZ7DS9908R
Equipment : Next Generation standard range Hands free scanner
Brand Name : Zebra
Model Name : DS9908R
Standard : FCC Part 15 Subpart C §15.247

The product was received on Feb. 11, 2019 and testing was started from Apr. 03, 2019 and completed on Apr. 13, 2019. We, SPORTON INTERNATIONAL INC., EMC & Wireless Communications Laboratory, would like to declare that the tested sample has been evaluated in accordance with the test procedures and has been in compliance with the applicable technical standards.

The report must not be used by the client to claim product certification, approval, or endorsement by TAF or any agency of government.

The test results in this report apply exclusively to the tested model / sample. Without written approval of SPORTON INTERNATIONAL INC. EMC & Wireless Communications Laboratory, the test report shall not be reproduced except in full.

Approved by: Jones Tsai

SPORTON INTERNATIONAL INC. EMC & Wireless Communications Laboratory
No. 52, Huaya 1st Rd., Guishan Dist., Taoyuan City, Taiwan (R.O.C.)



Table of Contents

History of this test report.....3

Summary of Test Result.....4

1 General Description.....5

 1.1 Applicant.....5

 1.2 Manufacturer.....5

 1.3 Product Feature of Equipment Under Test.....5

 1.4 Product Specification of Equipment Under Test.....6

 1.5 Modification of EUT6

 1.6 Testing Location6

 1.7 Applicable Standards.....7

2 Test Configuration of Equipment Under Test.....8

 2.1 Carrier Frequency Channel8

 2.2 Test Mode.....9

 2.3 Connection Diagram of Test System.....10

 2.4 Support Unit used in test configuration and system12

 2.5 EUT Operation Test Setup12

 2.6 Measurement Results Explanation Example.....12

3 Test Result.....13

 3.1 Number of Channel Measurement13

 3.2 Hopping Channel Separation Measurement15

 3.3 Dwell Time Measurement.....20

 3.4 20dB and 99% Bandwidth Measurement24

 3.5 Output Power Measurement.....33

 3.6 Conducted Band Edges Measurement.....35

 3.7 Conducted Spurious Emission Measurement40

 3.8 Radiated Band Edges and Spurious Emission Measurement44

 3.9 AC Power Line Conducted Emissions Measurement.....48

 3.10 Antenna Requirements.....50

4 List of Measuring Equipment51

5 Uncertainty of Evaluation.....52

Appendix A. AC Conducted Emission Test Result

Appendix B. Radiated Spurious Emission

Appendix C. Radiated Spurious Emission Plots

Appendix D. Duty Cycle Plots

Appendix E. Setup Photographs



History of this test report

Report No.	Version	Description	Issued Date
FR921127	01	Initial issue of report	Apr. 23, 2019



Summary of Test Result

Report Clause	Ref Std. Clause	Test Items	Result (PASS/FAIL)	Remark
3.1	15.247(a)(1)	Number of Channels	Pass	-
3.2	15.247(a)(1)	Hopping Channel Separation	Pass	-
3.3	15.247(a)(1)	Dwell Time of Each Channel	Pass	-
3.4	15.247(a)(1)	20dB Bandwidth	Pass	-
3.4	2.1049	99% Occupied Bandwidth	Reporting Only	-
3.5	15.247(b)(1)	Output Power	Pass	-
3.6	15.247(d)	Conducted Band Edges	Pass	-
3.7	15.247(d)	Conducted Spurious Emission	Pass	-
3.8	15.247(d)	Radiated Band Edges and Radiated Spurious Emission	Pass	Under limit 3.19 dB at 906.900 MHz
3.9	15.207	AC Conducted Emission	Pass	Under limit 3.16 dB at 19.235MHz
3.10	15.203 & 15.247(b)	Antenna Requirement	Pass	-

Declaration of Conformity:

The test results with all measurement uncertainty excluded are presented in accordance with the regulation limits or requirements declared by manufacturers.

Comments and Explanations:

The declared of product specification for EUT presented in the report are provided by the manufacturer, and the manufacturer takes all the responsibilities for the accuracy of product specification.

Reviewed by: Wii Chang

Report Producer: Maggie Chiang



1 General Description

1.1 Applicant

Zebra Technologies Corporation
1 Zebra Plaza, Holtsville, NY 11742

1.2 Manufacturer

1. **Universal Global Technology (Kunshan) Co., Ltd.**
Building 2 (A01) & Building 4, ASE Industrial Park, No. 497, Huangpujiang Road, Qiandeng Town, Kunshan City, Jiangsu Province 215341, P.R. China
2. **Universal Global Technology (Kunshan) Co., Ltd.**
NO. 135 & 141, Lane 351, Taiping Road, Sec. 1, Tsao Tuen, Nan-Tou 54261, Taiwan

1.3 Product Feature of Equipment Under Test

Product Feature	
Equipment	Next Generation standard range Hands free scanner
Brand Name	Zebra
Model Name	DS9908R
FCC ID	UZ7DS9908R
EUT supports Radios application	UHF RFID
HW Version	DV1
SW Version	N10
MFD	08MAR19
EUT Stage	Engineering Sample

Remark: The above EUT's information was declared by manufacturer.

Specification of Accessories				
Shielded USB Cable with Series A Connector	Brand Name	Zebra	Part Number	CBA-U30-S15ZBR
Coiled RS232 Cable	Brand Name	Zebra	Part Number	CBA-R06-C20PAR
AC Power Supply	Brand Name	Zebra	Part Number	PWR-WUA5V4W0US



1.4 Product Specification of Equipment Under Test

Standards-related Product Specification	
Tx/Rx Frequency Range	902.30 MHz ~ 927.75 MHz
Number of Channels	50
Maximum Output Power to Antenna	Conducted power from antenna side: Ant. V: 24.58 dBm (0.2871 W) Ant. H: 24.44 dBm (0.2780 W)
20dB Bandwidth	Ant. V: 0.070 MHz Ant. H: 0.070 MHz
99% Occupied Bandwidth	Ant. V: 0.068 MHz Ant. H: 0.068 MHz
Antenna Type / Gain	Ant. V: Dipole Antenna with gain -0.36 dBi Ant. H: Monopole Antenna with gain 0.41 dBi
Type of Modulation	ASK

1.5 Modification of EUT

No modifications are made to the EUT during all test items.

1.6 Testing Location

Test Site	SPORTON INTERNATIONAL INC.		
Test Site Location	No.52, Huaya 1st Rd., Guishan Dist., Taoyuan City, Taiwan (R.O.C.) TEL: +886-3-327-3456 FAX: +886-3-328-4978		
Test Site No.	Sporton Site No.		
	TH05-HY	CO05-HY	03CH07-HY

Note: The test site complies with ANSI C63.4 2014 requirement.

FCC designation No.: TW1190



1.7 Applicable Standards

According to the specifications of the manufacturer, the EUT must comply with the requirements of the following standards:

- ♦ FCC Part 15 Subpart C §15.247
- ♦ FCC KDB Publication No. 558074 D01 DTS Meas. Guidance v05r02
- ♦ FCC KDB 414788 D01 Radiated Test Site v01r01
- ♦ ANSI C63.10-2013

Remark:

1. All test items were verified and recorded according to the standards and without any deviation during the test.
2. This EUT has also been tested and complied with the requirements of FCC Part 15, Subpart B, recorded in a separate test report.



2 Test Configuration of Equipment Under Test

2.1 Carrier Frequency Channel

Frequency Band	Channel	Freq. (MHz)	Channel	Freq. (MHz)
902.30-927.75 MHz	0	902.30	27	916.09
	1	902.81	28	916.62
	2	903.32	29	917.15
	3	903.82	30	917.68
	4	904.33	31	918.21
	5	904.84	32	918.74
	6	905.35	33	919.27
	7	905.86	34	919.80
	8	906.37	35	920.33
	9	906.87	36	920.86
	10	907.38	37	921.39
	11	907.89	38	921.92
	12	908.40	39	922.45
	13	908.91	40	922.98
	14	909.42	41	923.51
	15	909.92	42	924.04
	16	910.43	43	924.57
	17	910.94	44	925.10
	18	911.45	45	925.63
	19	911.96	46	926.16
	20	912.47	47	926.69
	21	912.97	48	927.22
	22	913.48	49	927.75
	23	913.99		
	24	914.50		
	25	915.03		
	26	915.56		

2.2 Test Mode

- a. The EUT has been associated with peripherals and configuration operated in a manner tended to maximize its emission characteristics in a typical application. Frequency range investigated: conduction emission (150 kHz to 30 MHz), radiation emission (9 kHz to the 10th harmonic of the highest fundamental frequency or to 40 GHz, whichever is lower).
- b. AC power line Conducted Emission was tested under maximum output power.

The following summary table is showing all test modes to demonstrate in compliance with the standard.

Summary table of Test Cases	
Test Item	UHF RFID
Conducted Test Cases	<p><EUT with Ant. H> Mode 1: UHF RFID Tx CH00_902.30 MHz Mode 2: UHF RFID Tx CH24_914.50 MHz Mode 3: UHF RFID Tx CH49_927.75 MHz</p> <p><EUT with Ant. V> Mode 1: UHF RFID Tx CH00_902.30 MHz Mode 2: UHF RFID Tx CH24_914.50 MHz Mode 3: UHF RFID Tx CH50_927.75 MHz</p>
Radiated Test Cases	<p><EUT with Ant. H> Mode 1: UHF RFID Tx CH00_902.30 MHz</p> <p><EUT with Ant. V> Mode 1: UHF RFID Tx CH00_902.30 MHz Mode 2: UHF RFID Tx CH24_914.50 MHz Mode 3: UHF RFID Tx CH49_927.75 MHz</p>
AC Conducted Emission	<p>Mode 1: RFID on + EUT (Digital Scanner) Scan + PWR-WUA5V4W0US + CBA-R06-C20PAR (Data Link with PC)</p> <p>Mode 2: RFID on + EUT (Digital Scanner) Scan + CBA-U30-S15ZBR (Data Link with PC)</p>
Remark: The worst case of conducted emission is mode 2; only the test data of it was reported.	

2.3 Connection Diagram of Test System

<UHF RFID Tx Tx Mode>

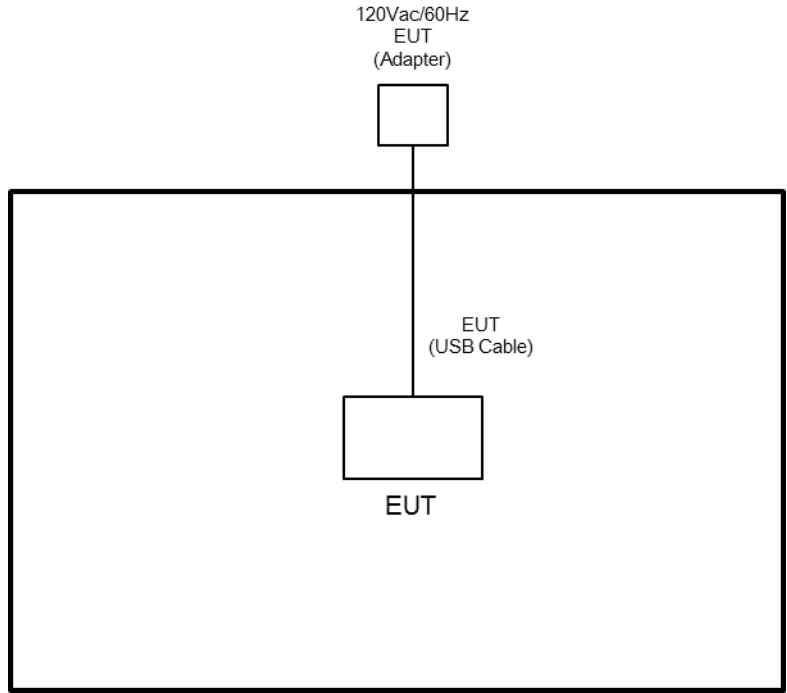

<AC Conducted Emissions with Adapter>

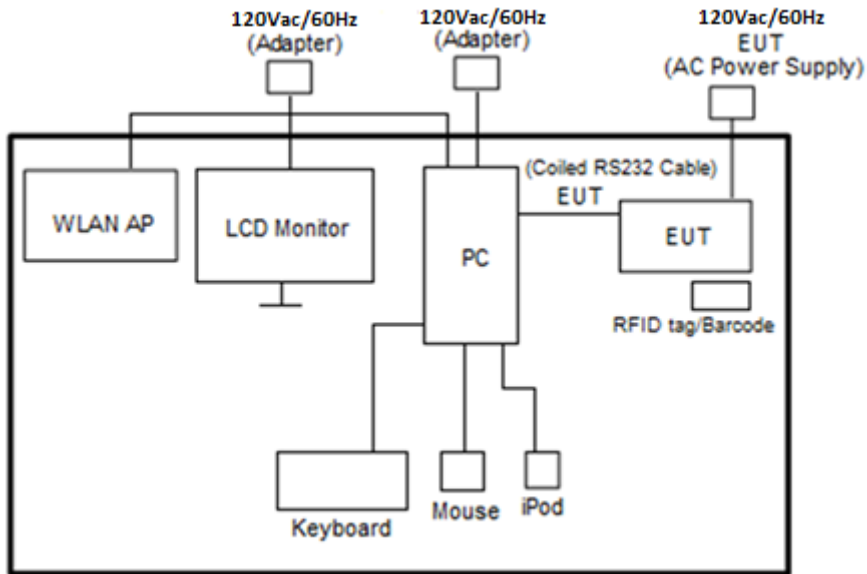

<AC Conducted Emissions with PC>

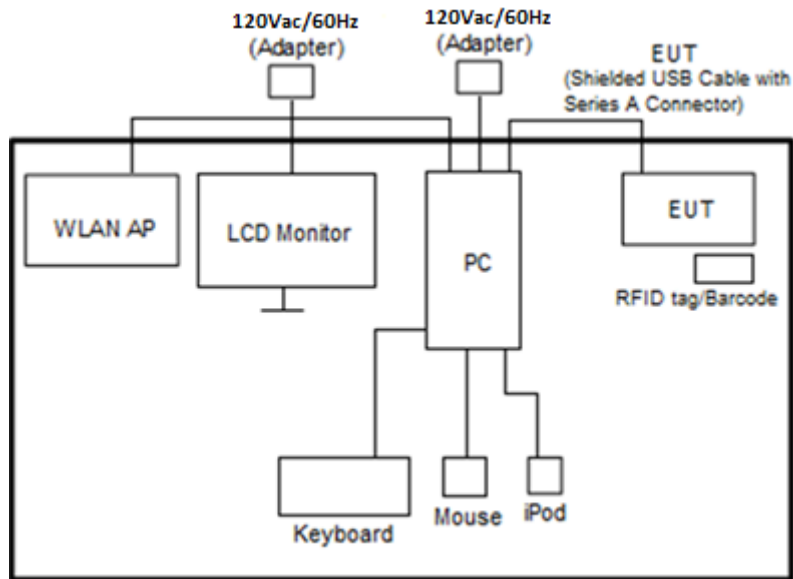



2.4 Support Unit used in test configuration and system

Item	Equipment	Trade Name	Model Name	FCC ID	Data Cable	Power Cord
1.	WLAN AP	NETGEAR	R70000	PY313200233	N/A	Unshielded, 1.8 m
2.	iPod	Apple	A1285	FCC DoC	Shielded, 1.0m	N/A
3.	PC	Lenovo	P320	FCC DoC	N/A	Unshielded, 1.2 m
4.	LCD Monitor	DELL	U2410	FCC DoC	Shielded, 1.6 m	Unshielded, 1.8 m
5.	Mouse	DELL	UAV-DEL8	FCC DoC	Unshielded, 1.5m	N/A
6.	Keyboard	Logitech	K200	FCC DoC	Shielded, 0.5 m	N/A
7.	RFID Tag	Zebra	N/A	FCC DoC	N/A	N/A
8.	Barcode	N/A	N/A	N/A	N/A	N/A

2.5 EUT Operation Test Setup

The RF test items, utility “Tera Term or Putty” was installed in PC which was programmed in order to make the EUT get into the engineering modes to provide channel selection, power level, data rate and the application type and for continuous transmitting signals.

2.6 Measurement Results Explanation Example

For all conducted test items:

The offset level is set in the spectrum analyzer to compensate the RF cable loss and attenuator factor between EUT conducted output port and spectrum analyzer. With the offset compensation, the spectrum analyzer reading level is exactly the EUT RF output level.

Example:

The spectrum analyzer offset is derived from RF cable loss and attenuator factor.

Offset = RF cable loss + attenuator factor.

Following shows an offset computation example with cable loss 4.2 dB and 10dB attenuator.

$$\begin{aligned} \text{Offset(dB)} &= \text{RF cable loss(dB)} + \text{attenuator factor(dB)}. \\ &= 4.2 + 10 = 14.2 \text{ (dB)} \end{aligned}$$

3 Test Result

3.1 Number of Channel Measurement

3.1.1 Limits of Number of Hopping Frequency

Frequency hopping systems in the 902.30-927.75 MHz band shall use at least 25 channels.

3.1.2 Measuring Instruments

See list of measuring equipment of this test report.

3.1.3 Test Procedure

1. The testing follows ANSI C63.10-2013 clause 7.8.3.
2. The RF output of EUT was connected to the spectrum analyzer by RF cable and attenuator. The path loss was compensated to the results for each measurement.
3. Set to the maximum power setting and enable the EUT transmit continuously.
4. Enable the EUT hopping function.
5. Use the following spectrum analyzer settings: Span = the frequency band of operation; RBW = 300kHz; VBW ≥ RBW; Sweep = auto; Detector function = peak; Trace = max hold.
6. The number of hopping frequency used is defined as the number of total channel.
7. Record the measurement data derived from spectrum analyzer.

3.1.4 Test Setup



3.1.5 Test Result of Number of Hopping Frequency

Test Mode :	UHF	Temperature :	21~25°C
Test Engineer :	Tommy Lee	Relative Humidity :	51~54%
Number of Hopping (Channel)	Limits (Channel)	Pass/Fail	
50	> 25	Pass	



<Ant. H>

Number of Hopping Channel Plot on Channel 00 - 49

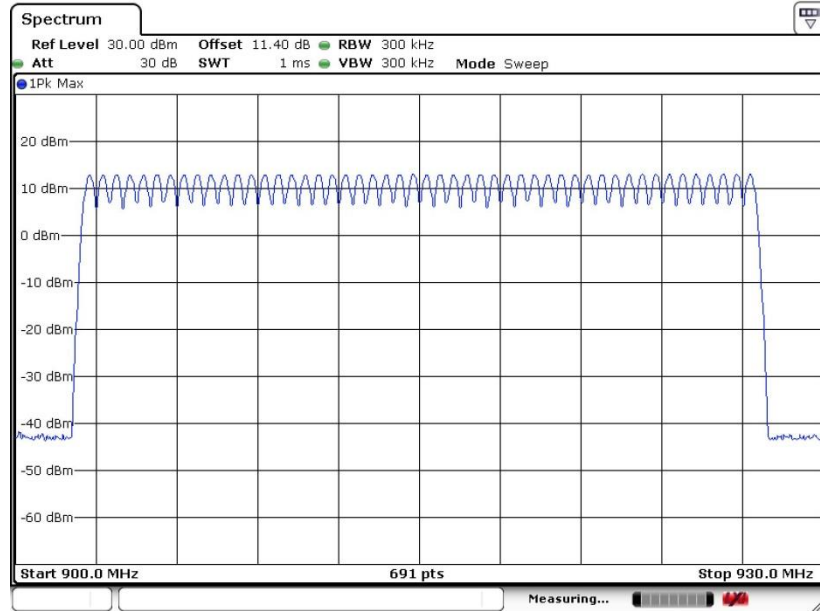

Date: 12.APR.2019 09:49:07

<Ant. V>

Number of Hopping Channel Plot on Channel 00 - 49

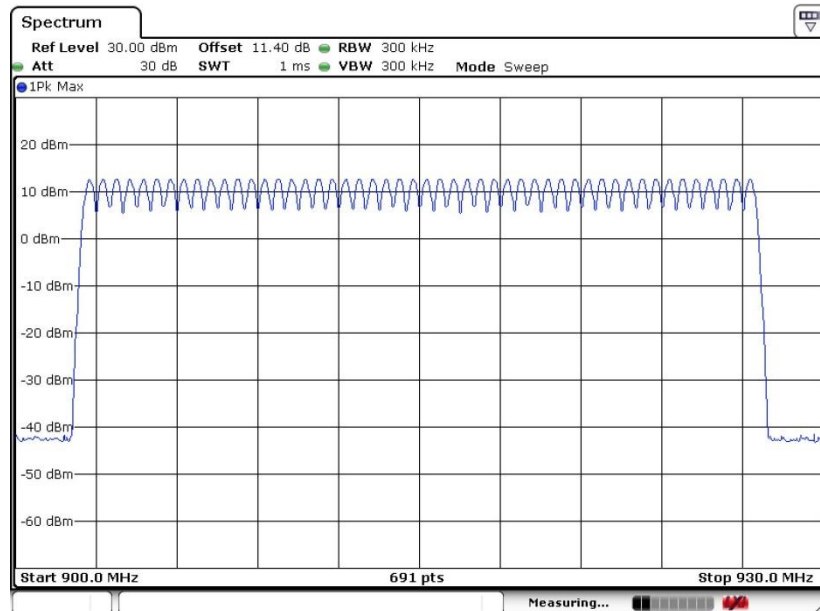

Date: 12.APR.2019 10:06:05

3.2 Hopping Channel Separation Measurement

3.2.1 Limit of Hopping Channel Separation

Frequency hopping systems operating in the 902.30-927.75 MHz band may have hopping channel carrier frequencies that are 20 dB bandwidth of the hopping channel, whichever is greater.

3.2.2 Measuring Instruments

See list of measuring equipment of this test report.

3.2.3 Test Procedures

1. The testing follows ANSI C63.10-2013 clause 7.8.2.
2. The RF output of EUT was connected to the spectrum analyzer by RF cable and attenuator. The path loss was compensated to the results for each measurement.
3. Set to the maximum power setting and enable the EUT transmit continuously.
4. Enable the EUT hopping function.
5. Use the following spectrum analyzer settings:
Span = wide enough to capture the peaks of two adjacent channels;
RBW = 300kHz; VBW \geq RBW; Sweep = auto; Detector function = peak; Trace = max hold.
6. Measure and record the results in the test report.

3.2.4 Test Setup

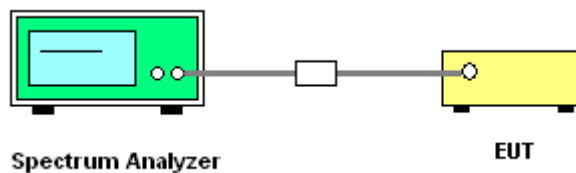

3.2.5 Test Result of Hopping Channel Separation

Test Mode :	UHF	Temperature :	21~25°C
Test Engineer :	Tommy Lee	Relative Humidity :	51~54%

<Ant. H>

Mod.	NTX	CH.	Freq. (MHz)	Hopping Channel Separation Measurement (MHz)	Hopping Channel Separation Measurement Limit (MHz)	Pass/Fail
UHF RFID	1	0	902.30	0.499	0.068	Pass
UHF RFID	1	24	914.50	0.499	0.068	Pass
UHF RFID	1	49	927.75	0.499	0.070	Pass

<Ant. V>

Mod.	NTX	CH.	Freq. (MHz)	Hopping Channel Separation Measurement (MHz)	Hopping Channel Separation Measurement Limit (MHz)	Pass/Fail
UHF RFID	1	0	902.30	0.499	0.070	Pass
UHF RFID	1	24	914.50	0.499	0.068	Pass
UHF RFID	1	49	927.75	0.499	0.068	Pass



<Ant. H>

Channel Separation Plot on Channel 00 - 01

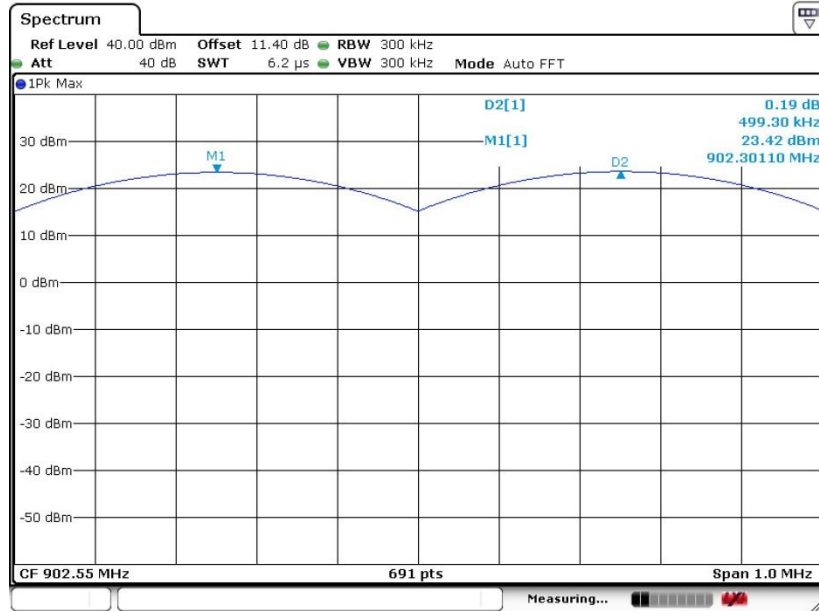

Date: 13.APR.2019 12:24:50

Channel Separation Plot on Channel 23.5 - 24.5

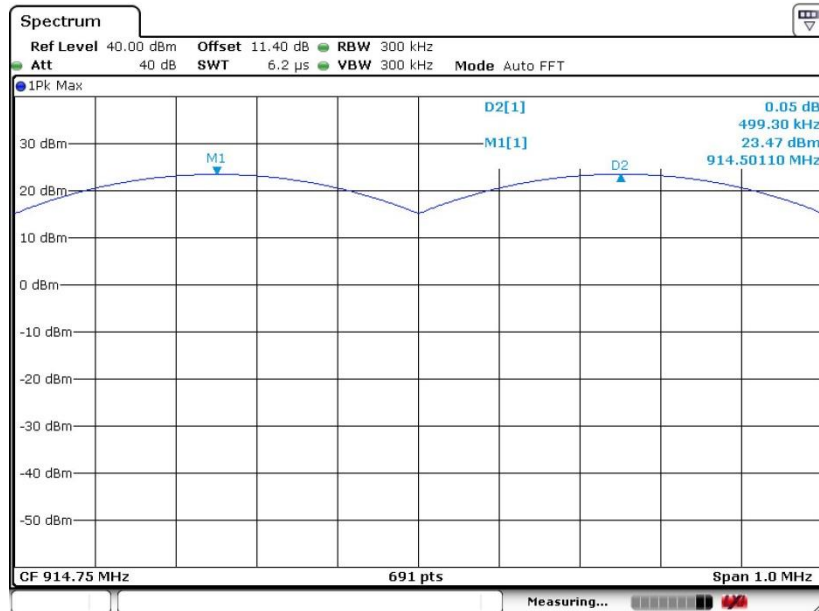

Date: 13.APR.2019 12:17:07



Channel Separation Plot on Channel 48 - 49

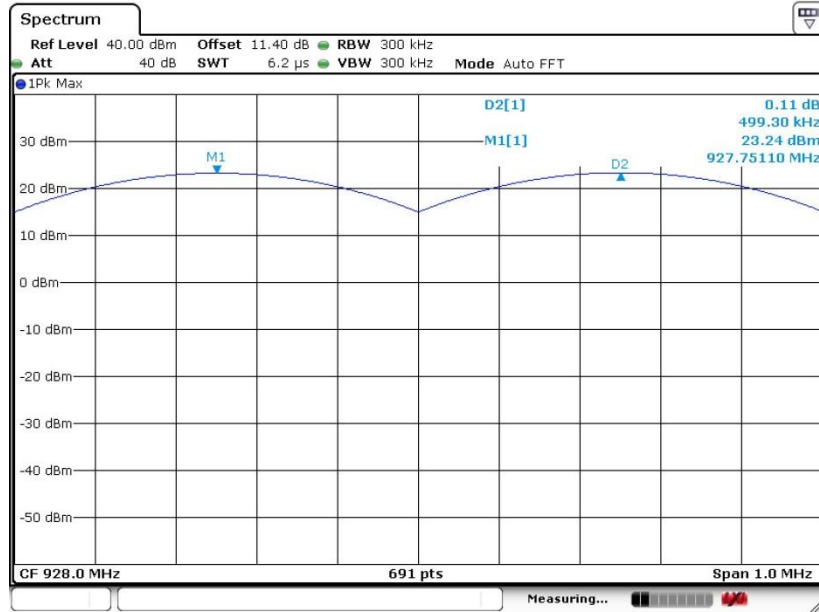

Date: 13.APR.2019 12:11:27

<Ant. V>

Channel Separation Plot on Channel 00 - 01

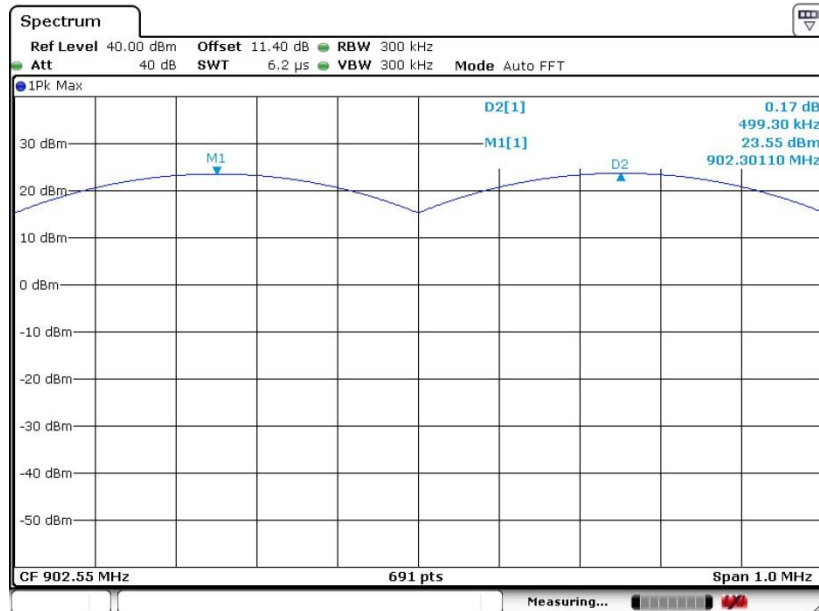

Date: 13.APR.2019 11:58:20



Channel Separation Plot on Channel 23.5 - 24.5

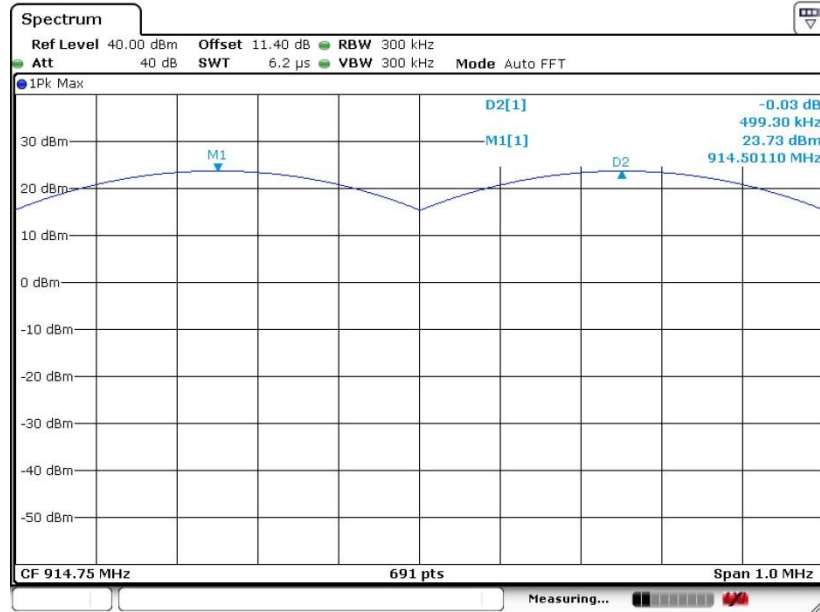

Date: 13.APR.2019 12:05:08

Channel Separation Plot on Channel 48 - 49

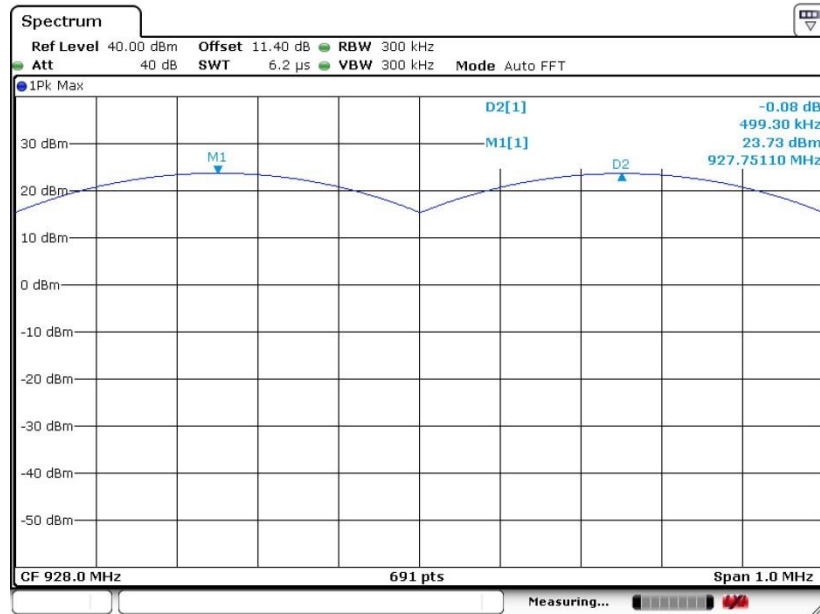

Date: 13.APR.2019 12:07:46

3.3 Dwell Time Measurement

3.3.1 Limit of Dwell Time

The average time of occupancy on any channel shall not be greater than 0.4 seconds within a period of 20 seconds multiplied by the number of hopping channels employed.

3.3.2 Measuring Instruments

See list of measuring equipment of this test report.

3.3.3 Test Procedures

1. The testing follows ANSI C63.10-2013 clause 7.8.4.
2. The RF output of EUT was connected to the spectrum analyzer by RF cable and attenuator. The path loss was compensated to the results for each measurement.
3. Set to the maximum power setting and enable the EUT transmit continuously.
4. Enable the EUT hopping function.
5. Use the following spectrum analyzer settings: Span = zero span, centered on a hopping channel; RBW = 1 MHz; VBW \geq RBW; Sweep = as necessary to capture the entire dwell time per hopping channel; Detector function = peak; Trace = max hold.
6. Measure and record the results in the test report.

3.3.4 Test Setup





3.3.5 Test Result of Dwell Time

Test Mode :	UHF	Temperature :	21~25°C
Test Engineer :	Tommy Lee	Relative Humidity :	51~54%

<Ant. H>

Mod.	Channel Number Rate	Package Transfer Time (msec)	Hops Over Occupancy Time (hops)	Dwell Time (sec)	Limits (sec)	Pass/Fail
Nomal	50	26.09	2.00	0.05	0.4	Pass

<Ant. V>

Mod.	Channel Number Rate	Package Transfer Time (msec)	Hops Over Occupancy Time (hops)	Dwell Time (sec)	Limits (sec)	Pass/Fail
Nomal	50	31.88	2.00	0.06	0.4	Pass



<Ant. H>

Package Transfer Time Plot

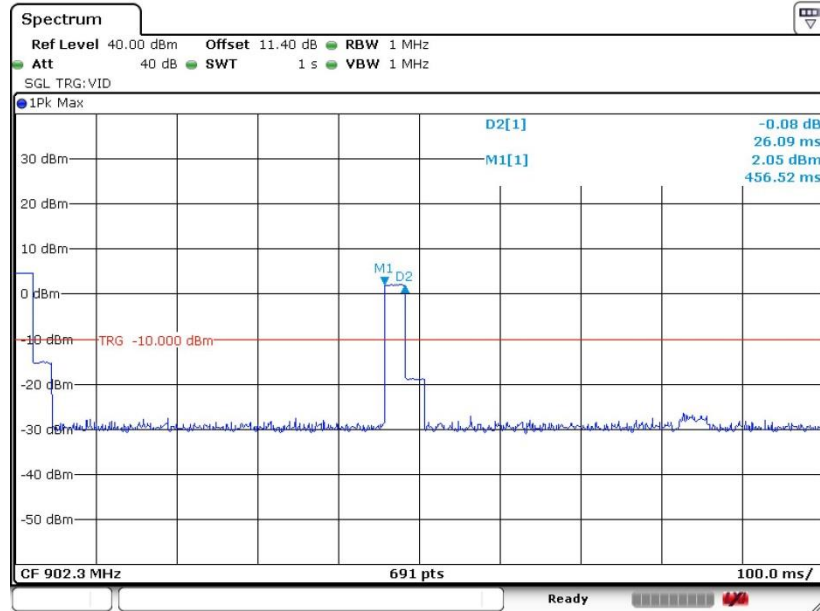

Date: 12.APR.2019 13:21:42

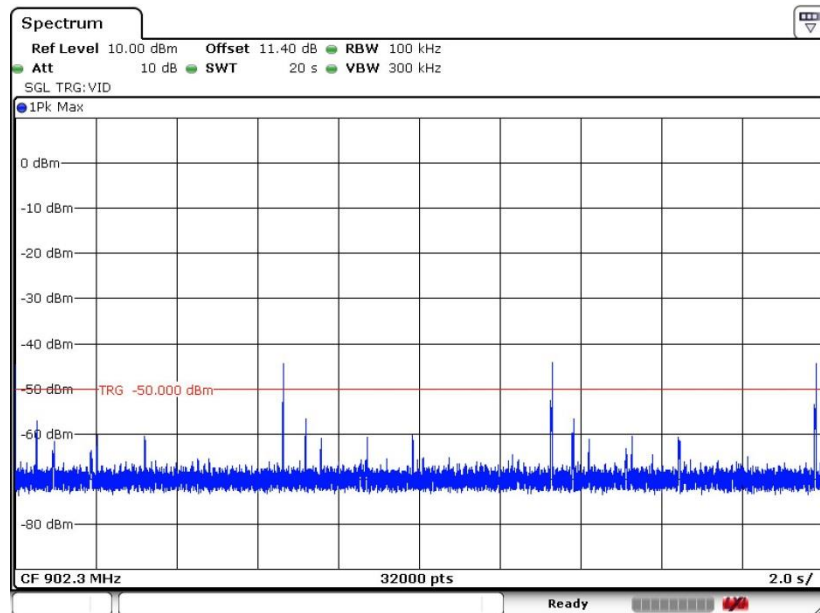

Date: 12.APR.2019 06:30:58



<Ant. V>

Package Transfer Time Plot

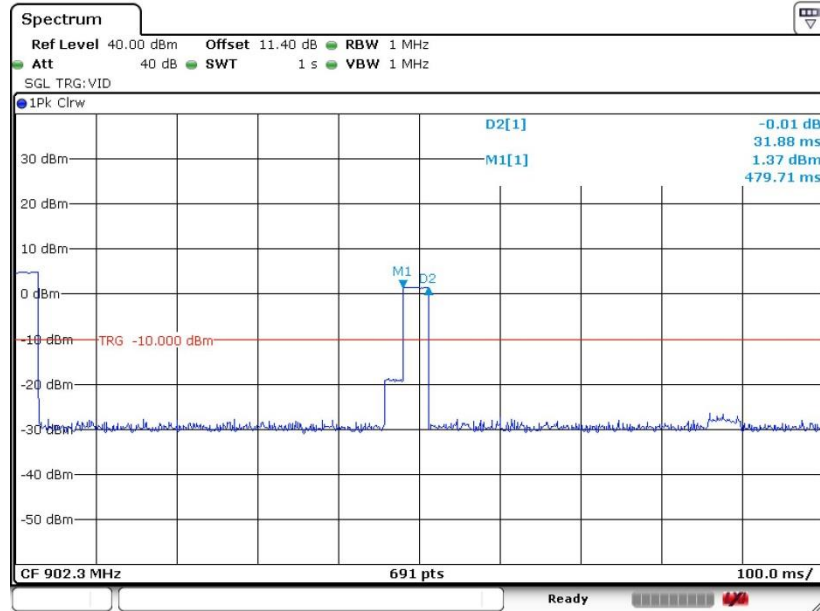

Date: 12.APR.2019 15:55:01

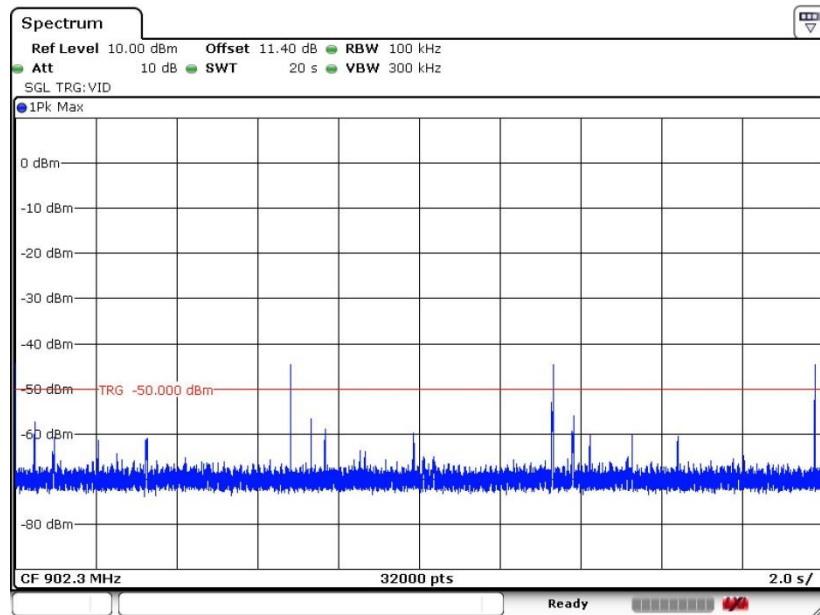

Date: 12.APR.2019 06:31:44

Remark: Dwell Time(s) = Hops Over Occupancy Time (hops) x Package Transfer Time

3.4 20dB and 99% Bandwidth Measurement

3.4.1 Limit of 20dB and 99% Bandwidth

Reporting only

3.4.2 Measuring Instruments

See list of measuring equipment of this test report.

3.4.3 Test Procedures

1. The testing follows ANSI C63.10-2013 clause 6.9.2 and 6.9.3.
2. The RF output of EUT was connected to the spectrum analyzer by RF cable and attenuator. The path loss was compensated to the results for each measurement.
3. Set to the maximum power setting and enable the EUT transmit continuously.
4. Use the following spectrum analyzer settings for 20dB Bandwidth measurement.
Span = approximately 2 to 5 times the 20 dB bandwidth, centered on a hopping channel;
RBW \geq 1% of the 20 dB bandwidth; VBW \geq RBW; Sweep = auto; Detector function = peak;
Trace = max hold.
5. Use the following spectrum analyzer settings for 99 % Bandwidth measurement.
Span = approximately 1.5 to 5 times the 99% bandwidth, centered on a hopping channel;
RBW \geq 1-5% of the 99% bandwidth; VBW \geq 3 * RBW; Sweep = auto; Detector function = peak;
Trace = max hold.
6. Measure and record the results in the test report.

3.4.4 Test Setup





3.4.5 Test Result of 20dB Bandwidth

Test Mode :	UHF	Temperature :	21~25°C
Test Engineer :	Tommy Lee	Relative Humidity :	51~54%

<Ant. H>

Mod.	N _{TX}	CH.	Freq.(MHz)	20db BW (MHz)	Pass/Fail
UHF RFID	1	0	902.30	0.068	Pass
UHF RFID	1	24	914.50	0.068	Pass
UHF RFID	1	49	927.75	0.070	Pass

<Ant. V>

Mod.	N _{TX}	CH.	Freq.(MHz)	20db BW (MHz)	Pass/Fail
UHF RFID	1	0	902.30	0.070	Pass
UHF RFID	1	24	914.50	0.068	Pass
UHF RFID	1	49	927.75	0.068	Pass

<Ant. H>

20 dB Bandwidth Plot on Channel 00

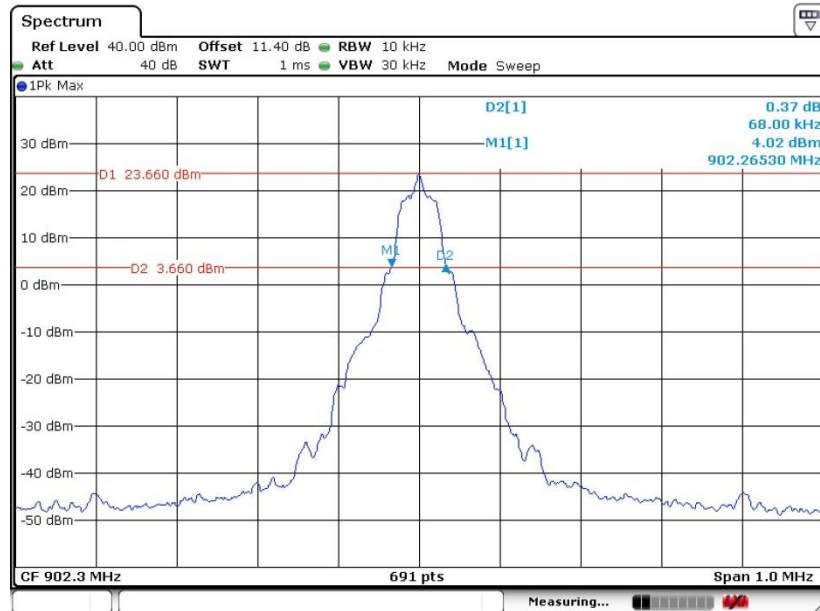

Date: 13.APR.2019 10:45:19



20 dB Bandwidth Plot on Channel 23.5

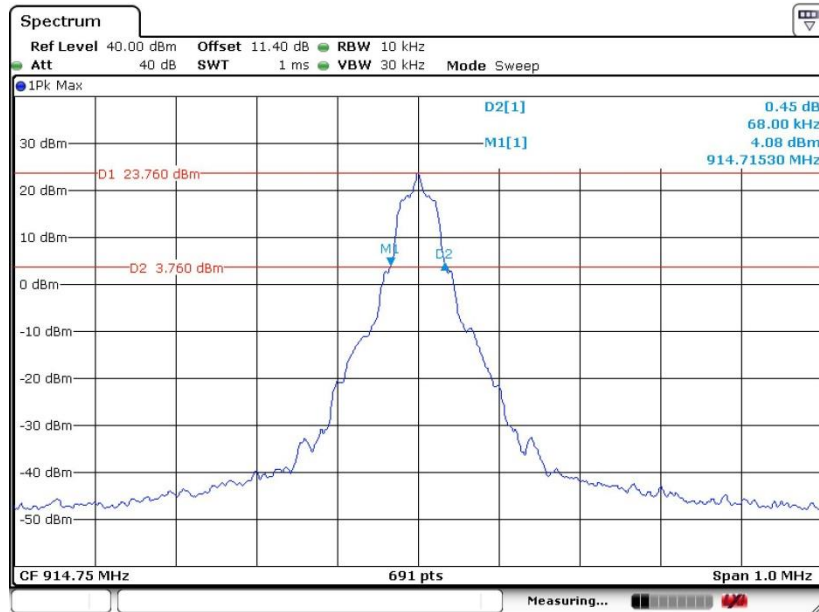

Date: 13.APR.2019 10:39:21

20 dB Bandwidth Plot on Channel 49

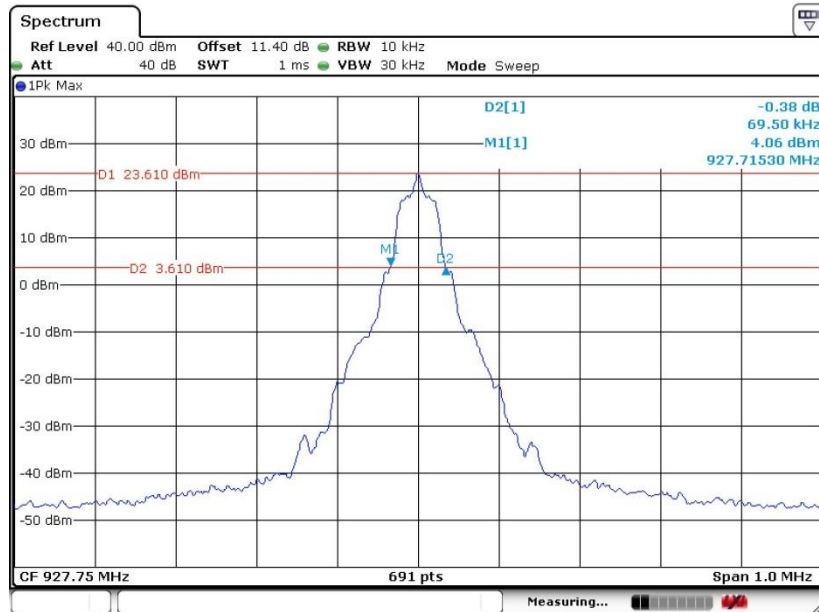

Date: 13.APR.2019 10:28:15



<Ant. V>

20 dB Bandwidth Plot on Channel 00

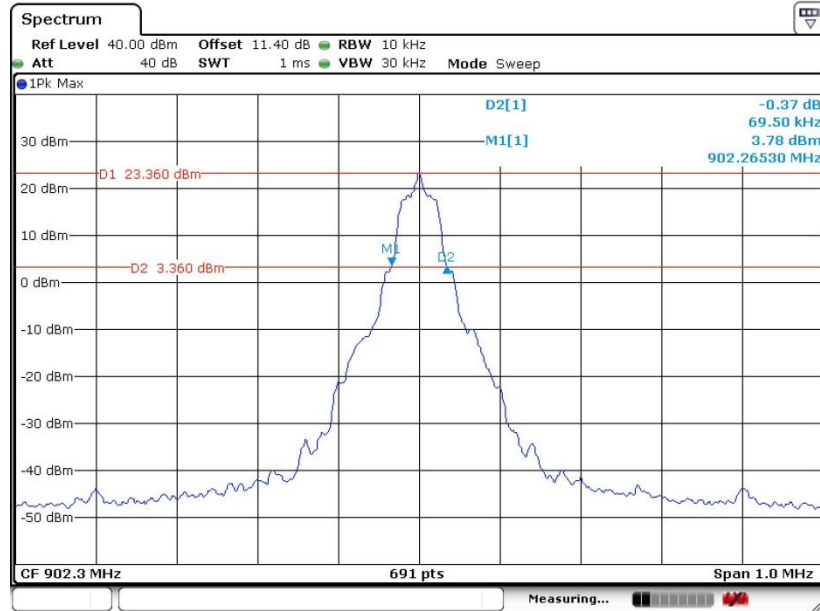

Date: 13.APR.2019 11:06:19

20 dB Bandwidth Plot on Channel 23.5

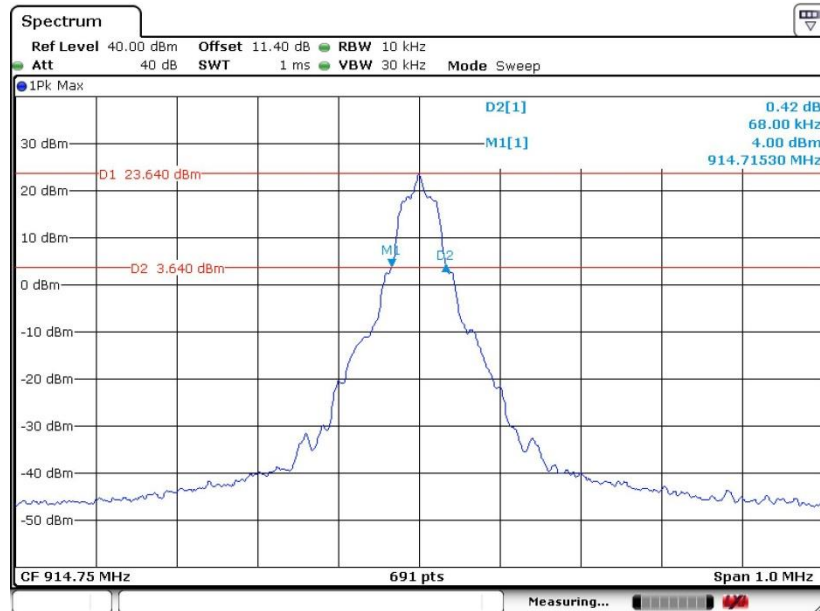

Date: 13.APR.2019 11:35:48



20 dB Bandwidth Plot on Channel 49

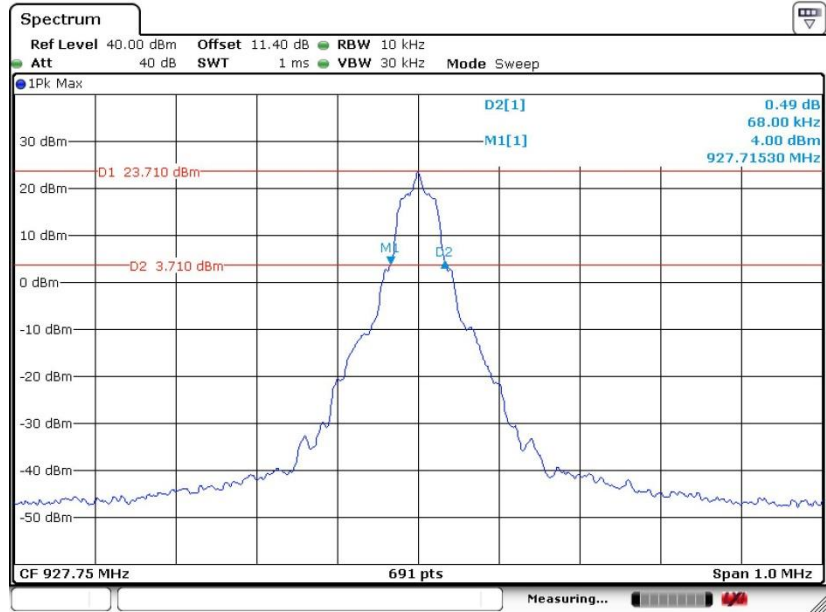

Date: 13.APR.2019 11:43:17



3.4.6 Test Result of 99% Occupied Bandwidth

Test Mode :	UHF	Temperature :	21~25°C
Test Engineer :	Tommy Lee	Relative Humidity :	51~54%

<Ant. H>

Mod.	NTX	CH.	Freq. (MHz)	99% Bandwidth (MHz)	Pass/Fail
UHF RFID	1	0	902.30	0.068	Pass
UHF RFID	1	24	914.50	0.068	Pass
UHF RFID	1	49	927.75	0.068	Pass

<Ant. V>

Mod.	NTX	CH.	Freq. (MHz)	99% Bandwidth (MHz)	Pass/Fail
UHF RFID	1	0	902.30	0.068	Pass
UHF RFID	1	24	914.50	0.068	Pass
UHF RFID	1	49	927.75	0.068	Pass

<Ant. H>

99% Occupied Bandwidth Plot on Channel 00

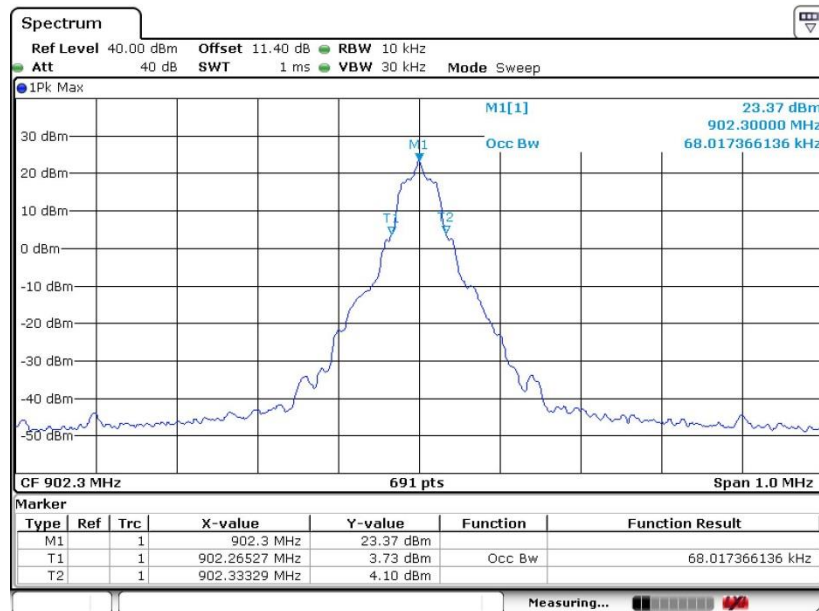

Date: 13.APR.2019 10:13:37



99% Occupied Bandwidth Plot on Channel 23.5

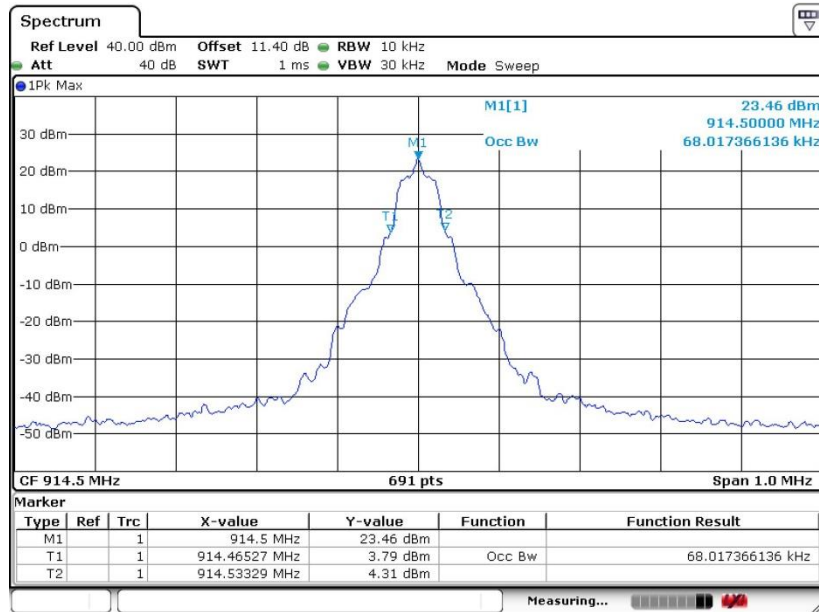

Date: 13.APR.2019 10:18:13

99% Occupied Bandwidth Plot on Channel 49

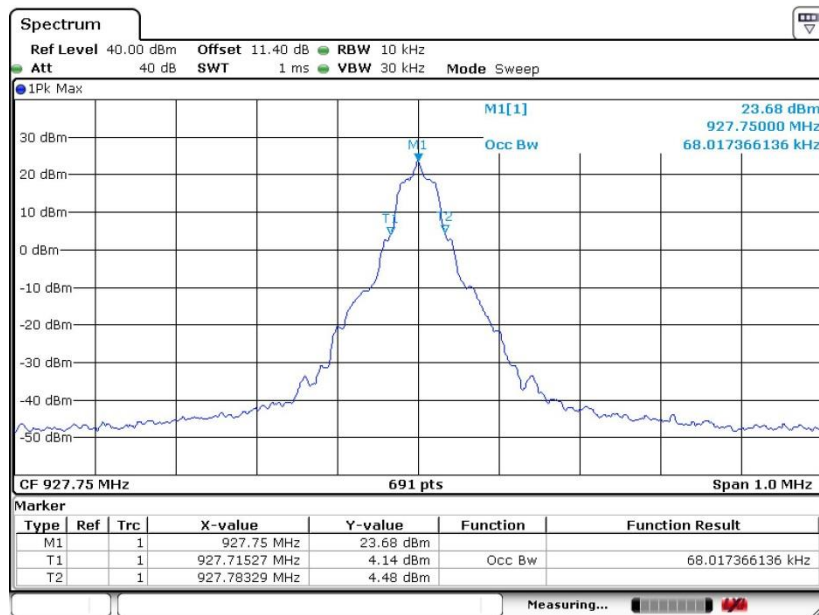

Date: 13.APR.2019 10:33:09



<Ant. V>

99% Occupied Bandwidth Plot on Channel 00

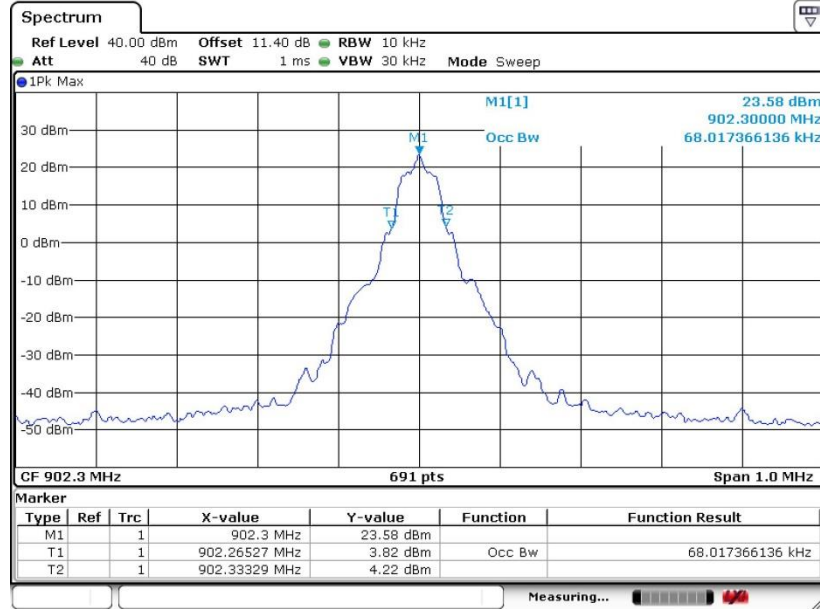

Date: 13.APR.2019 11:50:51

99% Occupied Bandwidth Plot on Channel 23.5

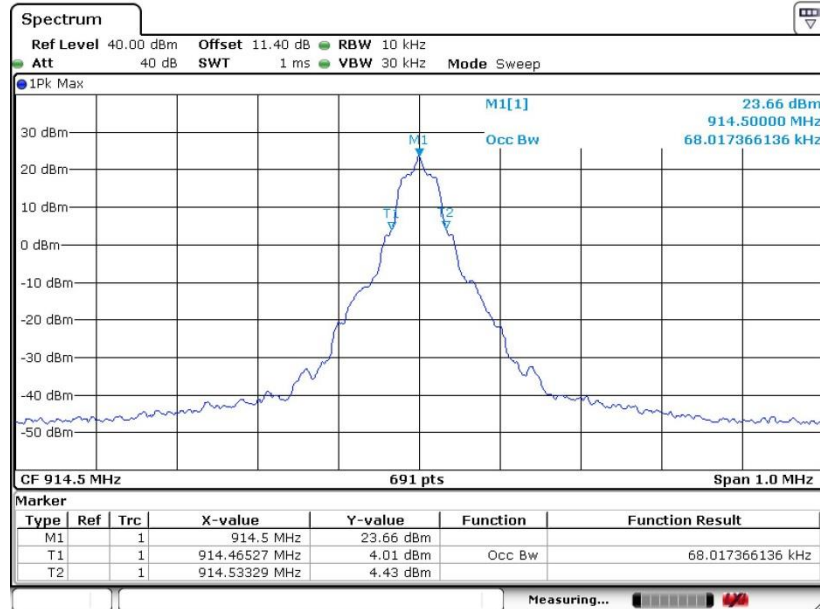

Date: 13.APR.2019 11:49:08



99% Occupied Bandwidth Plot on Channel 49

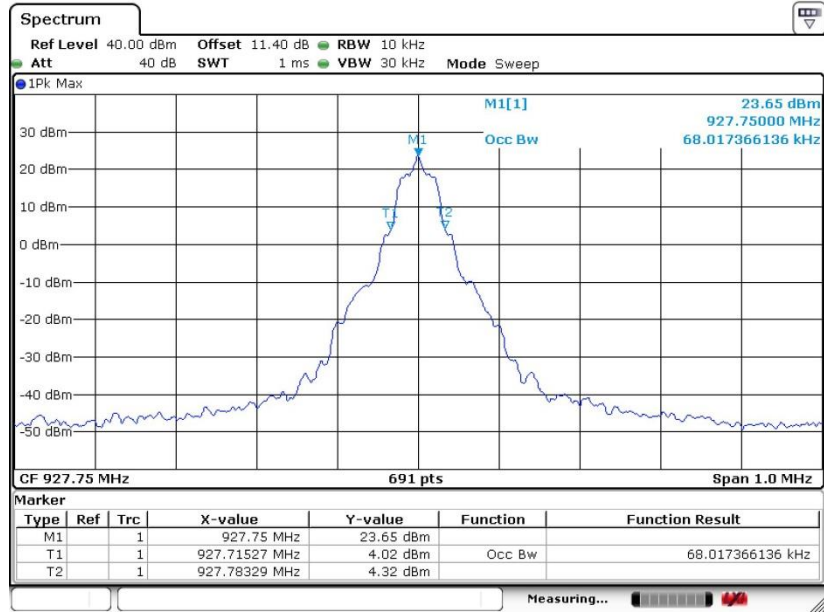

Date: 13.APR.2019 11:44:28

Note: The occupied channel bandwidth is maintained within the band of operation for all of the modulations.

3.5 Output Power Measurement

3.5.1 Limit of Output Power

Section 15.247 (a) Operation under the provisions of this Section is limited to frequency hopping and digitally modulated intentional radiators that comply with the following provisions: (1)(i) For frequency hopping systems operating in the 902-928 MHz band: if the 20 dB bandwidth of the hopping channel is less than 250 kHz, the system shall use at least 50 hopping frequencies and the average time of occupancy on any frequency shall not be greater than 0.4 seconds within a 20 second period; if the 20 dB bandwidth of the hopping channel is 250 kHz or greater, the system shall use at least 25 hopping frequencies and the average time of occupancy on any frequency shall not be greater than 0.4 seconds within a 10 second period. The maximum allowed 20 dB bandwidth of the hopping channel is 500 kHz.

Section 15.247 (b) The maximum peak conducted output power of the intentional radiator shall not exceed the following: (2) For frequency hopping systems operating in the 902-928 MHz band: 1 watt for systems employing at least 50 hopping channels; and, 0.25 watts for systems employing less than 50 hopping channels, but at least 25 hopping channels, as permitted under paragraph (a)(1)(i) of this section.

3.5.2 Measuring Instruments

See list of measuring equipment of this test report.

3.5.3 Test Procedures

1. The testing follows ANSI C63.10-2013 clause 7.8.5.
2. The RF output of EUT was connected to the power meter by RF cable and attenuator. The path loss was compensated to the results for each measurement.
3. Set to the maximum power setting and enable the EUT transmit continuously.
4. Measure the conducted output power with cable loss and record the results in the test report.
5. Measure and record the results in the test report.

3.5.4 Test Setup

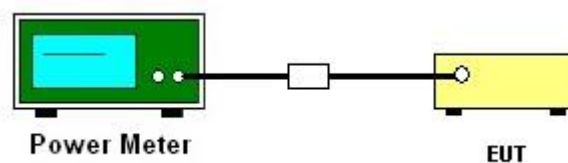



3.5.5 Test Result of Output Power

Test Mode :	UHF	Temperature :	21~25°C
Test Engineer :	Tommy Lee	Relative Humidity :	51~54%

<Ant. H>

Channel	Frequency (MHz)	RF Power (dBm)		
		UHF	Max. Limits (dBm)	Pass/Fail
0	902.30	24.44	30.00	Pass
24	914.50	24.32	30.00	Pass
49	927.75	24.30	30.00	Pass

<Ant. V>

Channel	Frequency (MHz)	RF Power (dBm)		
		UHF	Max. Limits (dBm)	Pass/Fail
0	902.30	24.58	30.00	Pass
24	914.50	24.42	30.00	Pass
49	927.75	24.37	30.00	Pass

3.6 Conducted Band Edges Measurement

3.6.1 Limit of Band Edges

In any 100 kHz bandwidth outside the intentional radiation frequency band, the radio frequency power shall be at least 20 dB below the highest level of the radiated power. In addition, radiated emissions which fall in the restricted bands must also comply with the radiated emission limits.

3.6.2 Measuring Instruments

See list of measuring equipment of this test report.

3.6.3 Test Procedures

1. The testing follows ANSI C63.10-2013 clause 7.8.6.
2. Set to the maximum power setting and enable the EUT transmit continuously.
3. Set RBW = 100kHz, VBW = 300kHz. Band edge emissions must be at least 20 dB down from the highest emission level within the authorized band as measured with a 100kHz RBW. The attenuation shall be 30 dB instead of 20 dB when RMS conducted output power procedure is used.
4. Enable hopping function of the EUT and then repeat step 2. and 3.
5. Measure and record the results in the test report.

3.6.4 Test Setup

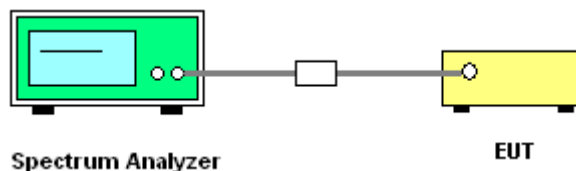



3.6.5 Test Result of Conducted Band Edges

<Ant. H>

Low Band Edge Plot on Channel 00

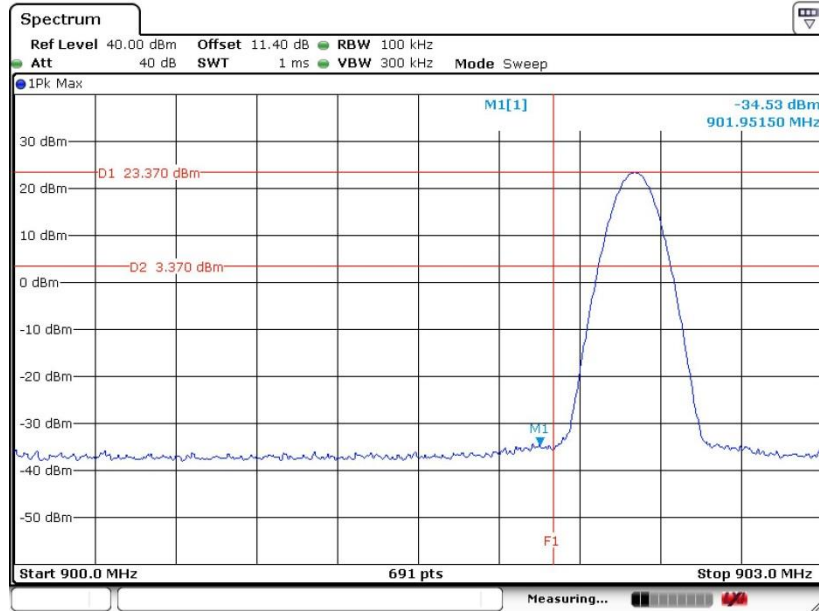

Date: 13.APR.2019 14:27:21

High Band Edge Plot on Channel 49

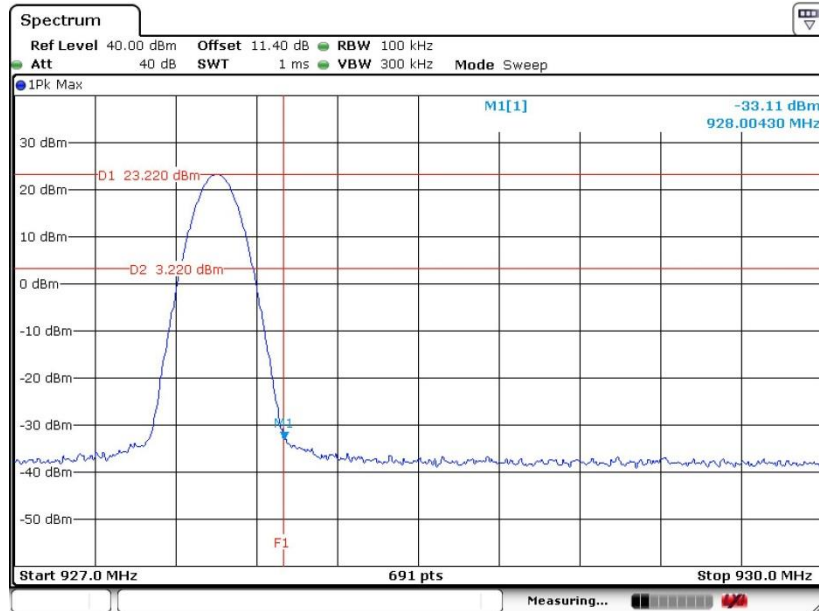

Date: 13.APR.2019 14:21:21



<Ant. V>

Low Band Edge Plot on Channel 00

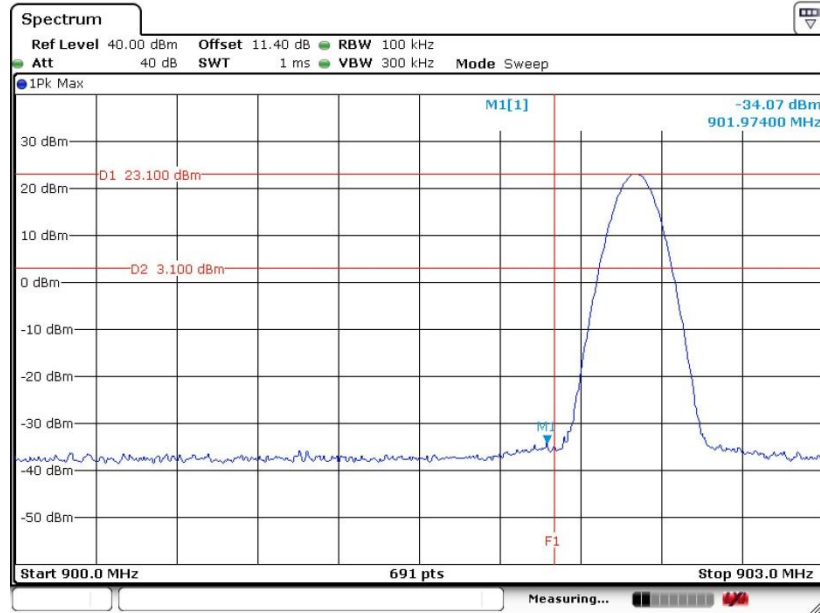

Date: 13.APR.2019 14:09:41

High Band Edge Plot on Channel 49

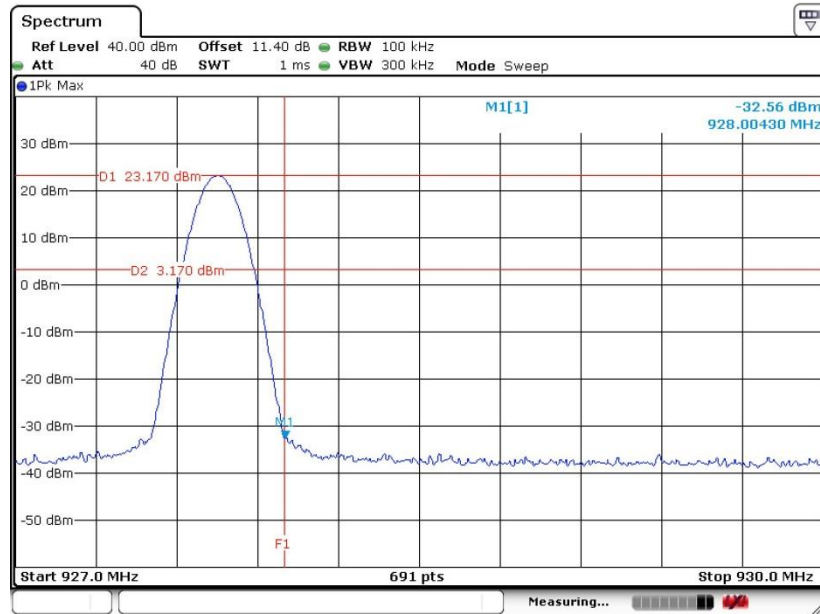

Date: 13.APR.2019 14:14:03



3.6.6 Test Result of Conducted Hopping Mode Band Edges

<Ant. H>

Hopping Mode Low Band Edge Plot

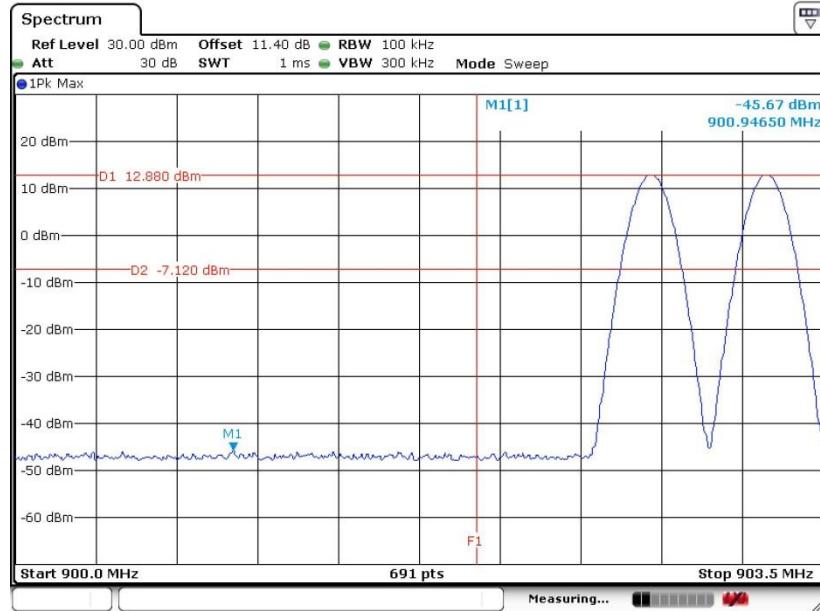

Date: 13.APR.2019 14:49:02

Hopping Mode High Band Edge Plot

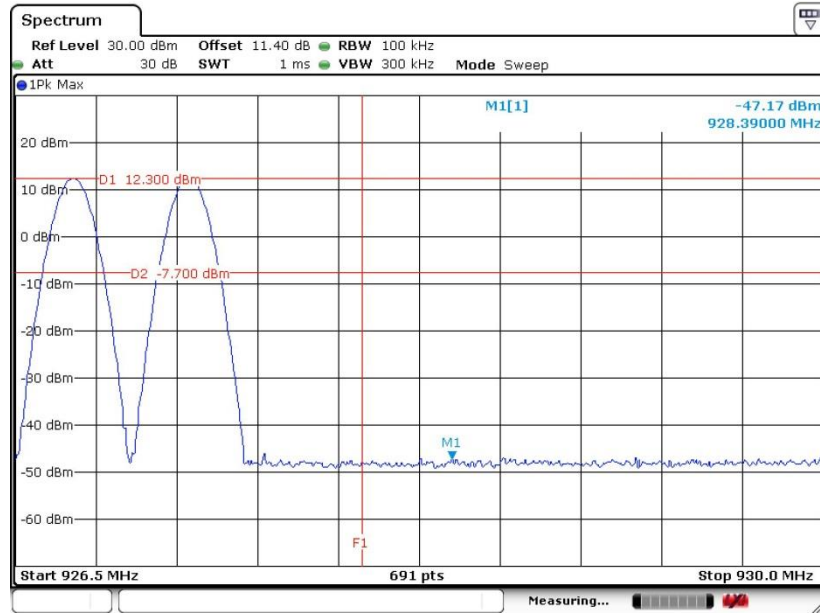

Date: 13.APR.2019 15:25:43



<Ant. V>

Hopping Mode Low Band Edge Plot

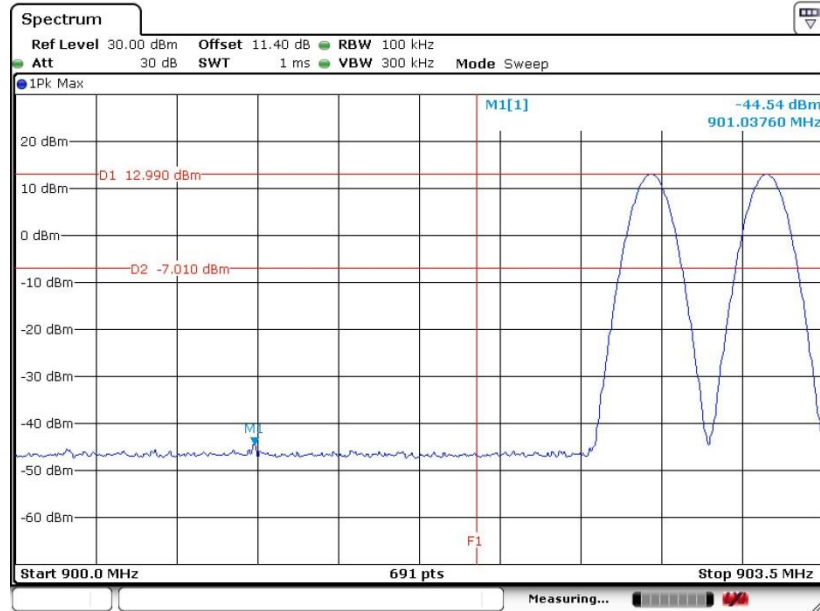

Hopping Mode High Band Edge Plot

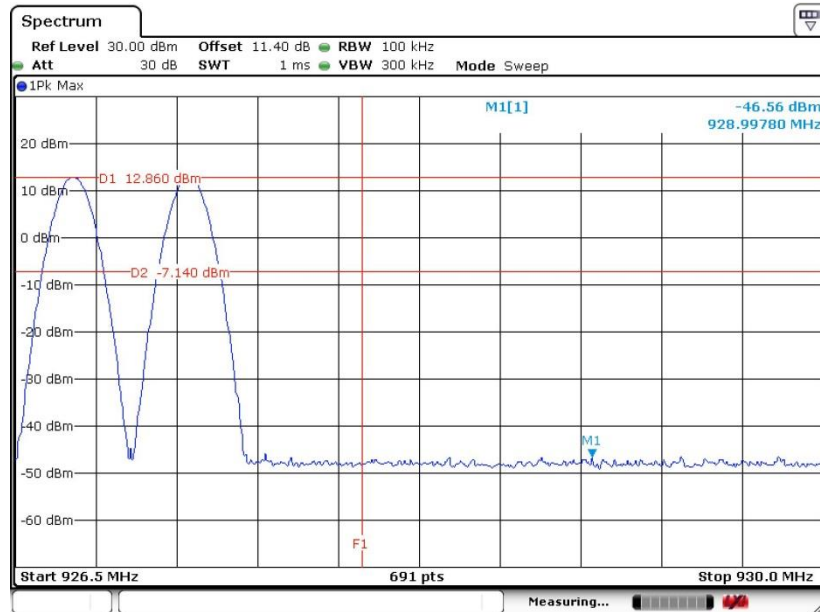

3.7 Conducted Spurious Emission Measurement

3.7.1 Limit of Spurious Emission Measurement

In any 100 kHz bandwidth outside the intentional radiation frequency band, the radio frequency power shall be at least 20 dB below the highest level of the radiated power. In addition, radiated emissions which fall in the restricted bands must also comply with the radiated emission limits.

3.7.2 Measuring Instruments

See list of measuring equipment of this test report.

3.7.3 Test Procedure

1. The testing follows ANSI C63.10-2013 clause 7.8.8.
2. The RF output of EUT was connected to the spectrum analyzer by RF cable and attenuator. The path loss was compensated to the results for each measurement.
3. Set to the maximum power setting and enable the EUT transmit continuously.
4. Set RBW = 100 kHz, VBW = 300kHz, scan up through 10th harmonic. All harmonics / spurs must be at least 20 dB down from the highest emission level within the authorized band as measured with a 100 kHz RBW.
5. Measure and record the results in the test report.
6. The RF fundamental frequency should be excluded against the limit line in the operating frequency band.

3.7.4 Test Setup





3.7.5 Test Result of Conducted Spurious Emission

<Ant. H>

CSE Plot on Ch 00 between 30MHz ~ 10 GHz

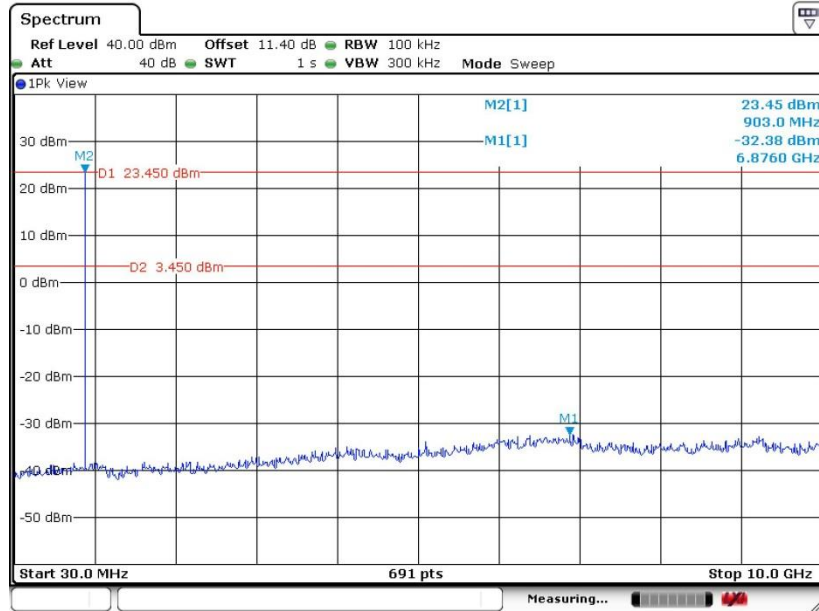

Date: 13.APR.2019 12:33:59

CSE Plot on Ch 24 between 30MHz ~ 10 GHz

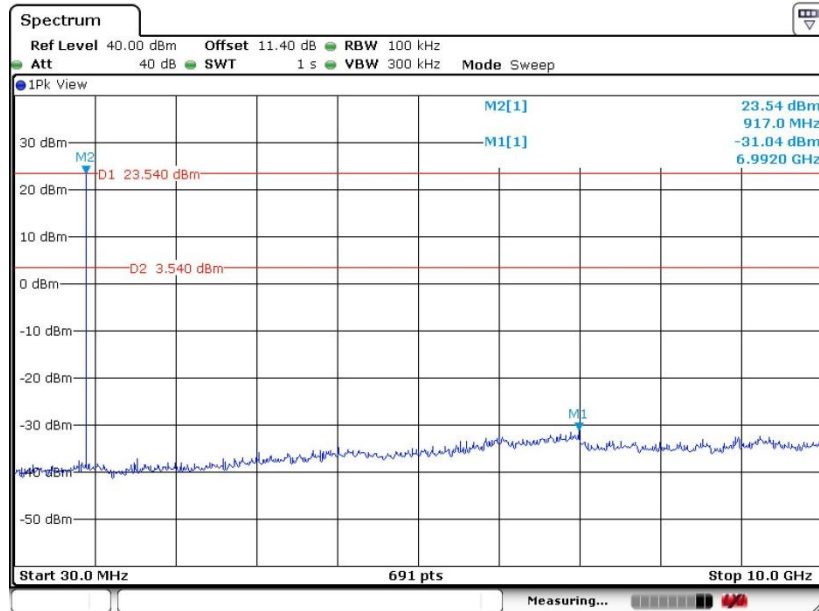

Date: 13.APR.2019 12:52:02



CSE Plot on Ch 49 between 30MHz ~ 10 GHz

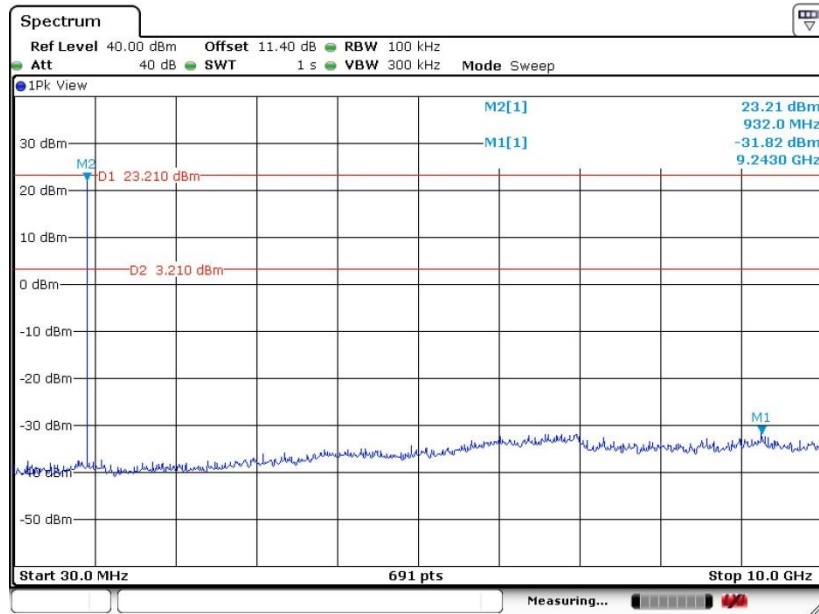

Date: 13.APR.2019 13:44:12

<Ant. V>

CSE Plot on Ch 00 between 30MHz ~ 10 GHz

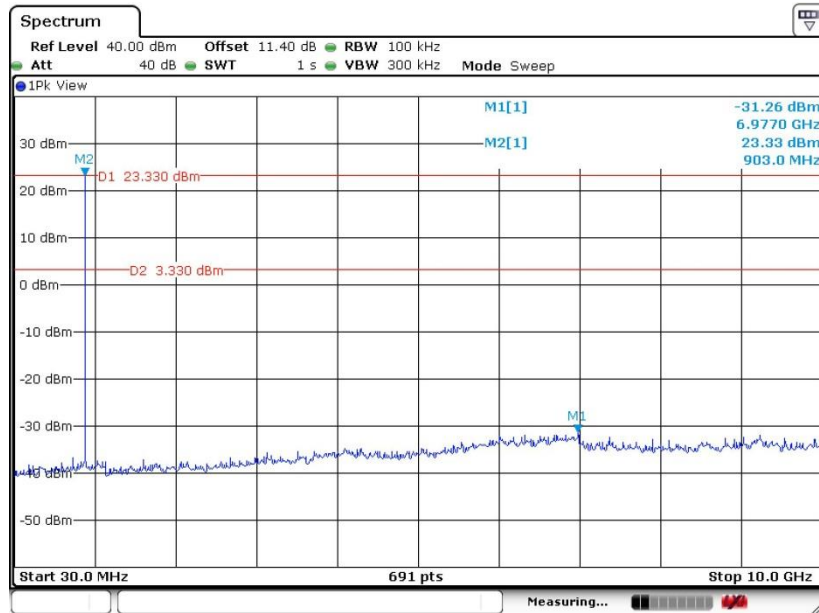

Date: 13.APR.2019 14:00:22



CSE Plot on Ch 24 between 30MHz ~ 10 GHz

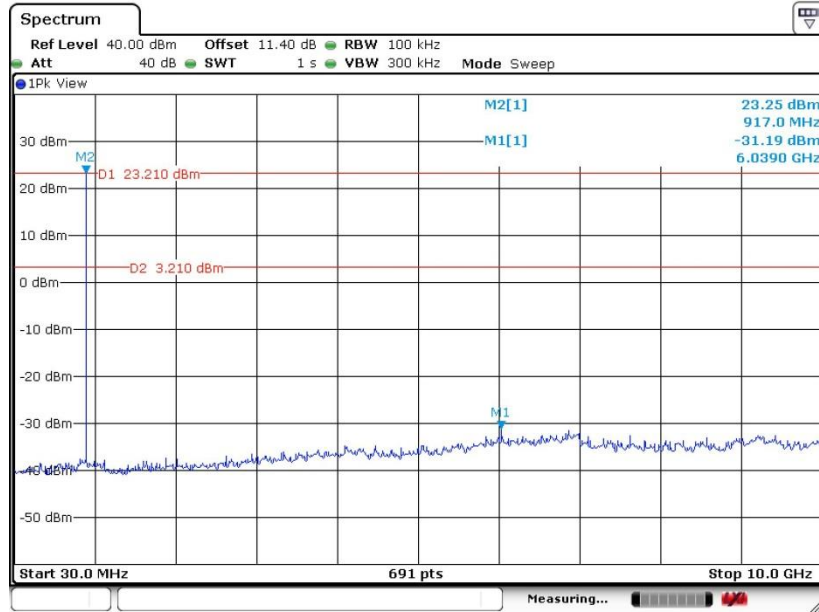

Date: 13.APR.2019 13:53:53

CSE Plot on Ch 49 between 30MHz ~ 10 GHz

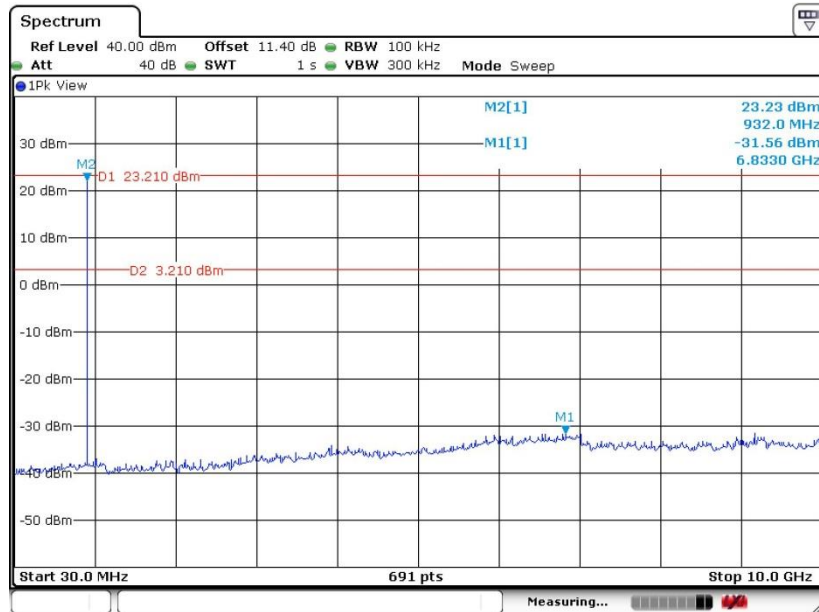

Date: 13.APR.2019 13:50:26



3.8 Radiated Band Edges and Spurious Emission Measurement

3.8.1 Limit of Radiated Band Edges and Spurious Emission

In any 100 kHz bandwidth outside the intentional radiator frequency band, all harmonics/spurious must be at least 20 dB below the highest emission level within the authorized band. In addition, radiated emissions which fall in the restricted bands must also comply with the limits as below.

Frequency (MHz)	Field Strength (microvolts/meter)	Measurement Distance (meters)
0.009 – 0.490	2400/F(kHz)	300
0.490 – 1.705	24000/F(kHz)	30
1.705 – 30.0	30	30
30 – 88	100	3
88 – 216	150	3
216 - 960	200	3
Above 960	500	3

3.8.2 Measuring Instruments

See list of measuring equipment of this test report.



3.8.3 Test Procedures

1. The EUT was placed on a turntable with 0.8 meter for frequency below 1GHz and 1.5 meter for frequency above 1GHz respectively above ground.
2. The EUT was set 3 meters from the interference receiving antenna, which was mounted on the top of a variable height antenna tower.
3. For each suspected emission, the EUT was arranged to its worst case and then tune the Antenna tower (from 1 m to 4 m) and turntable (from 0 degree to 360 degrees) to find the maximum reading. A pre-amp and a high pass filter are used for the test in order to get better signal level to comply with the guidelines.
4. Set to the maximum power setting and enable the EUT transmit continuously.
5. Use the following spectrum analyzer settings:
 - (1) Span shall wide enough to fully capture the emission being measured;
 - (2) Set RBW=100 kHz for $f < 1$ GHz, RBW=1MHz for $f > 1$ GHz ; VBW \geq RBW; Sweep = auto; Detector function = peak; Trace = max hold for peak
 - (3) For average measurement: use duty cycle correction factor method per 15.35(c).
Duty cycle = On time/100 milliseconds
On time = $N1*L1+N2*L2+...+Nn-1*LNn-1+Nn*Ln$
Where N1 is number of type 1 pulses, L1 is length of type 1 pulses, etc.
Average Emission Level = Peak Emission Level + $20*\log(\text{Duty cycle})$
6. Corrected Reading: Antenna Factor + Cable Loss + Read Level - Preamp Factor = Level

3.8.4 Test Setup

For radiated emissions below 30MHz

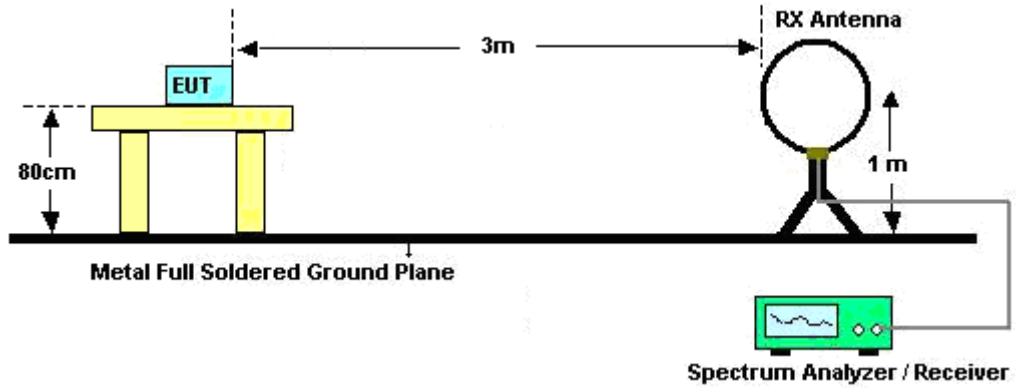

For radiated emissions from 30MHz to 1GHz

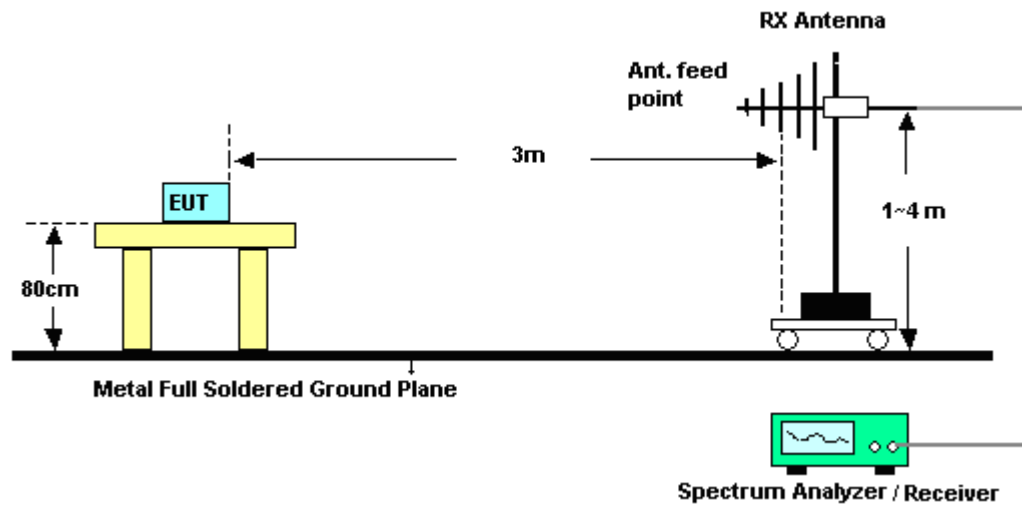

For radiated emissions above 1GHz

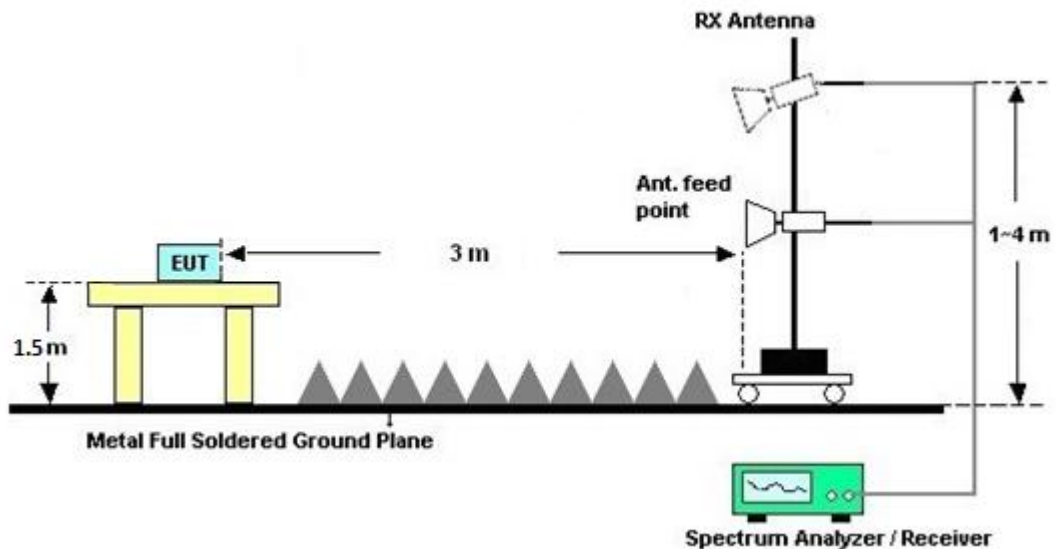



3.8.5 Test Results of Radiated Spurious Emissions (9 kHz ~ 30 MHz)

The low frequency, which started from 9 kHz to 30MHz, was pre-scanned and the result which was 20dB lower than the limit line was not reported.

There is a comparison data of both open-field test site and alternative test site - semi-Anechoic chamber according to 414788 D01 Radiated Test Site v01r01, and the result came out very similar.

3.8.6 Test Result of Radiated Spurious at Band Edges

Please refer to Appendix B and C.

3.8.7 Duty Cycle

Please refer to Appendix D.

3.8.8 Test Result of Radiated Spurious Emission

Please refer to Appendix B and C.



3.9 AC Power Line Conducted Emissions Measurement

3.9.1 Limit of AC Conducted Emission

For equipment that is designed to be connected to the public utility (AC) power line, the radio frequency voltage that is conducted back onto the AC power line on any frequency or frequencies within the band 150 kHz to 30 MHz shall not exceed the limits in the following table.

Frequency of Emission (MHz)	Conducted Limit (dBµV)	
	Quasi-Peak	Average
0.15-0.5	66 to 56*	56 to 46*
0.5-5	56	46
5-30	60	50

*Decreases with the logarithm of the frequency.

3.9.2 Measuring Instruments

See list of measuring equipment of this test report.

3.9.3 Test Procedures

1. The EUT was placed 0.4 meter from the conducting wall of the shielding room, and it was kept at least 80 centimeters from any other grounded conducting surface.
2. Connect EUT to the power mains through a line impedance stabilization network (LISN).
3. All the support units are connecting to the other LISN.
4. The LISN provides 50 ohm coupling impedance for the measuring instrument.
5. The FCC states that a 50 ohm, 50 microhenry LISN should be used.
6. Both sides of AC line were checked for maximum conducted interference.
7. The frequency range from 150 kHz to 30 MHz was searched.
8. Set the test-receiver system to Peak Detect Function and specified bandwidth (IF Bandwidth = 9kHz) with Maximum Hold Mode. Then measurement is also conducted by Average Detector and Quasi-Peak Detector Function respectively.

3.9.4 Test setup



3.9.5 Test Result of AC Conducted Emission

Please refer to Appendix A.



3.10 Antenna Requirements

3.10.1 Standard Applicable

If directional gain of transmitting Antennas is greater than 6dBi, the power shall be reduced by the same level in dB comparing to gain minus 6dBi. The use of a permanently attached Antenna or of an Antenna that uses a unique coupling to the intentional radiator shall be considered sufficient to comply with the rule.

3.10.2 Antenna Anti-Replacement Construction

An embedded-in antenna design is used.

3.10.3 Antenna Gain

The antenna peak gain of EUT is 6 dBi. Therefore, it is not necessary to reduce maximum peak output power limit.



4 List of Measuring Equipment

Instrument	Manufacturer	Model No.	Serial No.	Characteristics	Calibration Date	Test Date	Due Date	Remark
Power Meter	Anritsu	ML2495A	1218006	N/A	Oct. 08, 2018	Apr. 03, 2019~ Apr. 13, 2019	Oct. 07, 2019	Conducted (TH05-HY)
Power Sensor	Anritsu	MA2411B	1207363	300MHz~40GHz	Oct. 08, 2018	Apr. 03, 2019~ Apr. 13, 2019	Oct. 07, 2019	Conducted (TH05-HY)
Power Sensor	DARE	RPR3006W	16I00054SNO 12	10MHz~6GHz	Dec. 27, 2018	Apr. 03, 2019~ Apr. 13, 2019	Dec. 26, 2019	Conducted (TH05-HY)
Spectrum Analyzer	Rohde & Schwarz	FSV40	101397	10Hz~40GHz	Nov. 13, 2018	Apr. 03, 2019~ Apr. 13, 2019	Nov. 12, 2019	Conducted (TH05-HY)
Switch Box & RF Cable	Burgeon	ETF-058	EC1208382	N/A	Mar. 27, 2019	Apr. 03, 2019~ Apr. 13, 2019	Mar. 26, 2020	Conducted (TH05-HY)
AC Power Source	ChainTek	APC-1000W	N/A	N/A	N/A	Apr. 11, 2019	N/A	Conduction (CO05-HY)
EMI Test Receiver	Rohde & Schwarz	ESR3	102388	9KHz~3.6GHz	Nov. 12, 2018	Apr. 11, 2019	Nov. 11, 2019	Conduction (CO05-HY)
LISN	Rohde & Schwarz	ENV216	100080	9kHz~30MHz	Nov. 14, 2018	Apr. 11, 2019	Nov. 13, 2019	Conduction (CO05-HY)
Software	Rohde & Schwarz	EMC32 V10.30	N/A	N/A	N/A	Apr. 11, 2019	N/A	Conduction (CO05-HY)
LF Cable	HUBER + SUHNER	RG-214/U	LF01	N/A	Dec. 31, 2018	Apr. 11, 2019	Dec. 30, 2019	Conduction (CO05-HY)
Pulse Limiter	Rohde & Schwarz	ESH3-Z2	100851	N/A	Dec. 31, 2018	Apr. 11, 2019	Dec. 30, 2019	Conduction (CO05-HY)
Bilog Antenna	TESEQ	CBL 6111D&00800 N1D01N-06	35419&03	30MHz to 1GHz	Jan. 10, 2019	Apr. 10, 2019~ Apr. 11, 2019	Jan. 09, 2020	Radiation (03CH07-HY)
Double Ridge Horn Antenna	ESCO	3117	00075962	1GHz ~ 18GHz	Dec. 02, 2018	Apr. 10, 2019~ Apr. 11, 2019	Dec. 03, 2019	Radiation (03CH07-HY)
Loop Antenna	Rohde & Schwarz	HFH2-Z2	100315	9 kHz~30 MHz	Jan. 11, 2019	Apr. 10, 2019~ Apr. 11, 2019	Jan. 10, 2020	Radiation (03CH07-HY)
Preamplifier	MITEQ	AMF-7D-0010 1800-30-10P	1590075	1GHz ~ 18GHz	Apr. 25, 2018	Apr. 10, 2019~ Apr. 11, 2019	Apr. 24, 2019	Radiation (03CH07-HY)
Antenna Mast	Max-Full	MFA520BS	N/A	1m~4m	N/A	Apr. 10, 2019~ Apr. 11, 2019	N/A	Radiation (03CH07-HY)
Turn Table	ChainTek	Chaintek 3000	N/A	0~360 Degree	N/A	Apr. 10, 2019~ Apr. 11, 2019	N/A	Radiation (03CH07-HY)
EMI Test Receiver	Agilent	N9038A (MXE)	MY53290053	20Hz to 26.5GHz	Jan. 23, 2019	Apr. 10, 2019~ Apr. 11, 2019	Jan. 22, 2020	Radiation (03CH07-HY)
Preamplifier	MITEQ	AMF-7D-0010 1800-30-10P	1590075	1GHz ~ 18GHz	Apr. 25, 2018	Apr. 10, 2019~ Apr. 11, 2019	Apr. 24, 2019	Radiation (03CH07-HY)
Preamplifier	COM-POWER	PA-103A	161241	10MHz-1GHz	May 21, 2018	Apr. 10, 2019~ Apr. 11, 2019	May 20, 2019	Radiation (03CH07-HY)
Software	Audix	E3 6.2009-8-24	N/A	N/A	N/A	Apr. 10, 2019~ Apr. 11, 2019	N/A	Radiation (03CH07-HY)



5 Uncertainty of Evaluation

Uncertainty of Conducted Emission Measurement (150kHz ~ 30MHz)

Measuring Uncertainty for a Level of Confidence of 95% ($U = 2Uc(y)$)	2.2
---	-----

Uncertainty of Radiated Emission Measurement (30 MHz ~ 1000 MHz)

Measuring Uncertainty for a Level of Confidence of 95% ($U = 2Uc(y)$)	5.7
---	-----

Uncertainty of Radiated Emission Measurement (1000 MHz ~ 18000 MHz)

Measuring Uncertainty for a Level of Confidence of 95% ($U = 2Uc(y)$)	5.5
---	-----

Uncertainty of Radiated Emission Measurement (18000 MHz ~ 40000 MHz)

Measuring Uncertainty for a Level of Confidence of 95% ($U = 2Uc(y)$)	5.2
---	-----



Appendix A. AC Conducted Emission Test Results

Test Mode :	Mode 1	Temperature :	24~26°C
Test Engineer :	Jimmy Chang	Relative Humidity :	51~54%
Test Voltage :	120Vac / 60Hz	Phase :	Line
Test Mode :	RFID on + EUT (Digital Scanner) Scan + PWR-WUA5V4W0US + CBA-R06-C20PAR (Data Link with PC)		

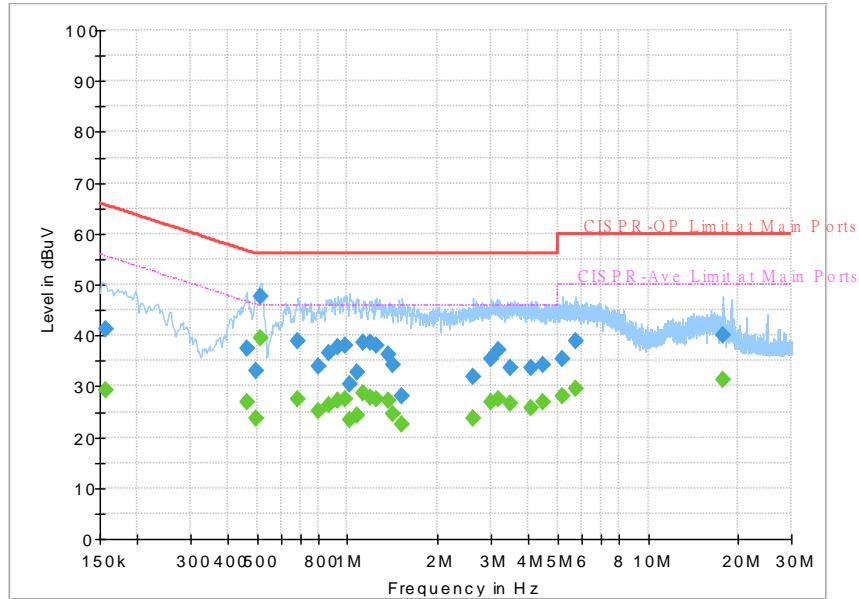

Final Result

Frequency (MHz)	QuasiPeak (dBuV)	CAverage (dBuV)	Limit (dBuV)	Margin (dB)	Line	Filter	Corr. (dB)
0.156750	---	29.38	55.63	26.25	L1	OFF	19.5
0.156750	41.19	---	65.63	24.44	L1	OFF	19.5
0.462750	---	26.95	46.64	19.69	L1	OFF	19.5
0.462750	37.40	---	56.64	19.24	L1	OFF	19.5
0.494250	---	23.59	46.10	22.51	L1	OFF	19.5
0.494250	33.12	---	56.10	22.98	L1	OFF	19.5
0.514500	---	39.59	46.00	6.41	L1	OFF	19.5
0.514500	47.64	---	56.00	8.36	L1	OFF	19.5
0.685500	---	27.51	46.00	18.49	L1	OFF	19.6
0.685500	38.81	---	56.00	17.19	L1	OFF	19.6
0.798000	---	25.15	46.00	20.85	L1	OFF	19.6
0.798000	33.83	---	56.00	22.17	L1	OFF	19.6
0.867750	---	26.30	46.00	19.70	L1	OFF	19.6
0.867750	36.43	---	56.00	19.57	L1	OFF	19.6
0.926250	---	27.21	46.00	18.79	L1	OFF	19.6
0.926250	37.72	---	56.00	18.28	L1	OFF	19.6
0.984750	---	27.58	46.00	18.42	L1	OFF	19.6
0.984750	37.87	---	56.00	18.13	L1	OFF	19.6
1.014000	---	23.50	46.00	22.50	L1	OFF	19.6
1.014000	30.49	---	56.00	25.51	L1	OFF	19.6
1.072500	---	24.27	46.00	21.73	L1	OFF	19.6
1.072500	32.82	---	56.00	23.18	L1	OFF	19.6



Test Mode :	Mode 1	Temperature :	24~26°C
Test Engineer :	Jimmy Chang	Relative Humidity :	51~54%
Test Voltage :	120Vac / 60Hz	Phase :	Line
Test Mode :	RFID on + EUT (Digital Scanner) Scan + PWR-WUA5V4W0US + CBA-R06-C20PAR (Data Link with PC)		

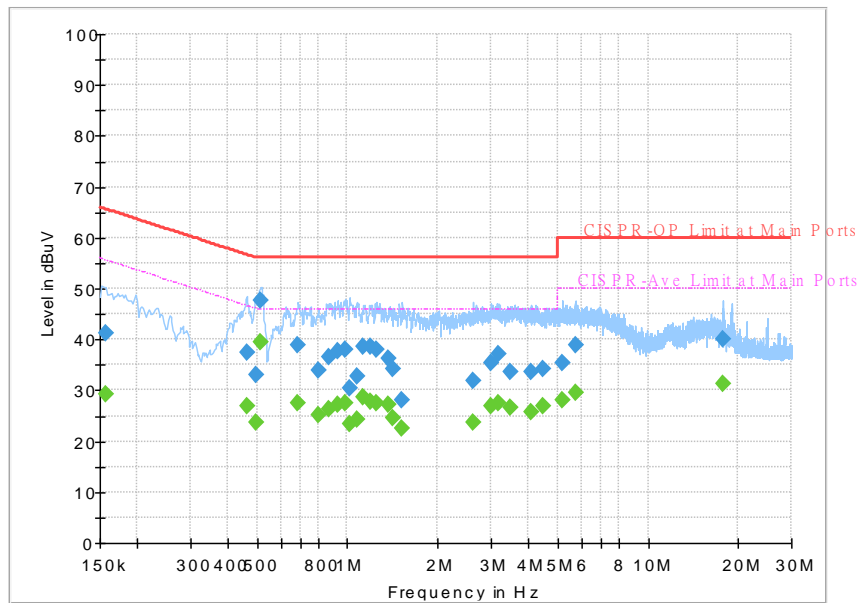

Final Result

Frequency (MHz)	QuasiPeak (dBuV)	CAverage (dBuV)	Limit (dBuV)	Margin (dB)	Line	Filter	Corr. (dB)
1.131000	---	28.66	46.00	17.34	L1	OFF	19.6
1.131000	38.49	---	56.00	17.51	L1	OFF	19.6
1.196250	---	27.78	46.00	18.22	L1	OFF	19.6
1.196250	38.66	---	56.00	17.34	L1	OFF	19.6
1.250250	---	27.60	46.00	18.40	L1	OFF	19.6
1.250250	38.04	---	56.00	17.96	L1	OFF	19.6
1.365000	---	27.06	46.00	18.94	L1	OFF	19.6
1.365000	36.27	---	56.00	19.73	L1	OFF	19.6
1.423500	---	24.51	46.00	21.49	L1	OFF	19.6
1.423500	34.24	---	56.00	21.76	L1	OFF	19.6
1.522500	---	22.63	46.00	23.37	L1	OFF	19.6
1.522500	28.19	---	56.00	27.81	L1	OFF	19.6
2.613750	---	23.73	46.00	22.27	L1	OFF	19.6
2.613750	31.96	---	56.00	24.04	L1	OFF	19.6
3.014250	---	26.84	46.00	19.16	L1	OFF	19.6
3.014250	35.29	---	56.00	20.71	L1	OFF	19.6
3.196500	---	27.41	46.00	18.59	L1	OFF	19.6
3.196500	37.12	---	56.00	18.88	L1	OFF	19.6
3.495750	---	26.51	46.00	19.49	L1	OFF	19.7
3.495750	33.53	---	56.00	22.47	L1	OFF	19.7
4.094250	---	25.79	46.00	20.21	L1	OFF	19.7
4.094250	33.50	---	56.00	22.50	L1	OFF	19.7



Test Mode :	Mode 1	Temperature :	24~26°C
Test Engineer :	Jimmy Chang	Relative Humidity :	51~54%
Test Voltage :	120Vac / 60Hz	Phase :	Line
Test Mode :	RFID on + EUT (Digital Scanner) Scan + PWR-WUA5V4W0US + CBA-R06-C20PAR (Data Link with PC)		

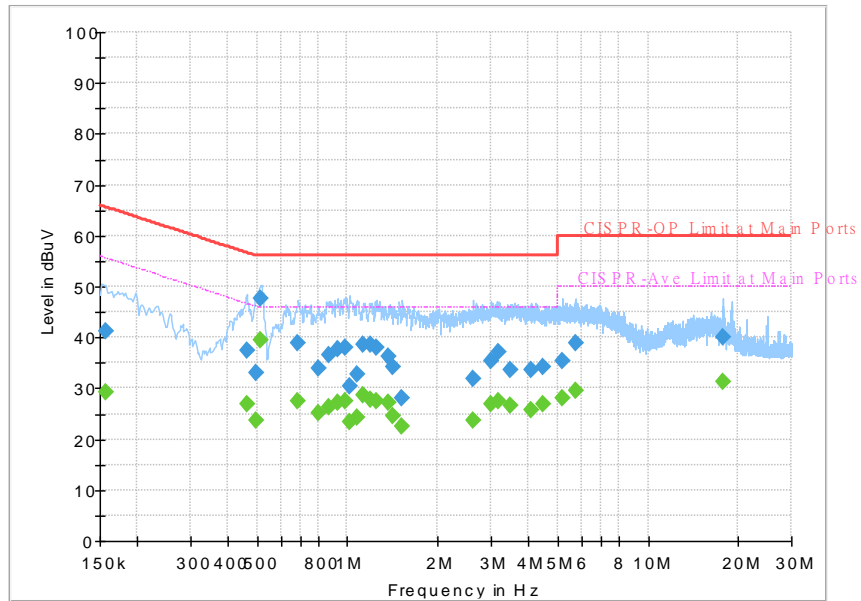

Final Result

Frequency (MHz)	QuasiPeak (dBuV)	CAverage (dBuV)	Limit (dBuV)	Margin (dB)	Line	Filter	Corr. (dB)
4.449750	---	26.88	46.00	19.12	L1	OFF	19.7
4.449750	34.18	---	56.00	21.82	L1	OFF	19.7
5.172000	---	28.20	50.00	21.80	L1	OFF	19.7
5.172000	35.24	---	60.00	24.76	L1	OFF	19.7
5.716500	---	29.60	50.00	20.40	L1	OFF	19.8
5.716500	39.03	---	60.00	20.97	L1	OFF	19.8
17.769750	---	31.31	50.00	18.69	L1	OFF	20.2
17.769750	40.06	---	60.00	19.94	L1	OFF	20.2



Test Mode :	Mode 1	Temperature :	24~26°C
Test Engineer :	Jimmy Chang	Relative Humidity :	51~54%
Test Voltage :	120Vac / 60Hz	Phase :	Neutral
Test Mode :	RFID on + EUT (Digital Scanner) Scan + PWR-WUA5V4W0US + CBA-R06-C20PAR (Data Link with PC)		

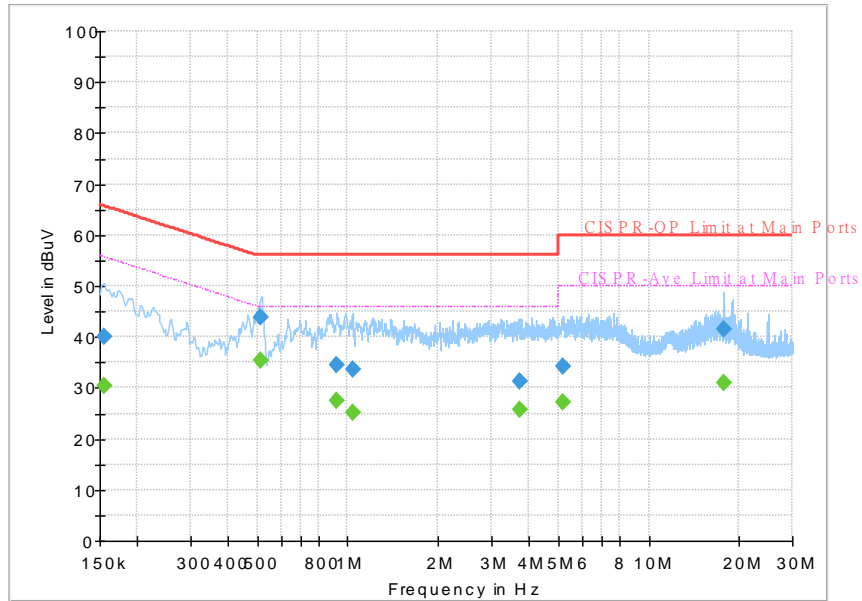

Final Result

Frequency (MHz)	QuasiPeak (dBuV)	CAverage (dBuV)	Limit (dBuV)	Margin (dB)	Line	Filter	Corr. (dB)
0.154500	---	30.27	55.75	25.48	N	OFF	19.5
0.154500	39.92	---	65.75	25.83	N	OFF	19.5
0.514500	---	35.35	46.00	10.65	N	OFF	19.5
0.514500	43.74	---	56.00	12.26	N	OFF	19.5
0.919500	---	27.43	46.00	18.57	N	OFF	19.6
0.919500	34.50	---	56.00	21.50	N	OFF	19.6
1.036500	---	25.17	46.00	20.83	N	OFF	19.6
1.036500	33.51	---	56.00	22.49	N	OFF	19.6
3.727500	---	25.78	46.00	20.22	N	OFF	19.7
3.727500	31.19	---	56.00	24.81	N	OFF	19.7
5.169750	---	27.15	50.00	22.85	N	OFF	19.7
5.169750	34.08	---	60.00	25.92	N	OFF	19.7
17.767500	---	30.99	50.00	19.01	N	OFF	20.2
17.767500	41.40	---	60.00	18.60	N	OFF	20.2



Test Mode :	Mode 2	Temperature :	24~26°C
Test Engineer :	Jimmy Chang	Relative Humidity :	51~54%
Test Voltage :	120Vac / 60Hz	Phase :	Line
Test Mode :	RFID on + EUT (Digital Scanner) Scan + CBA-U30-S15ZBR (Data Link with PC)		

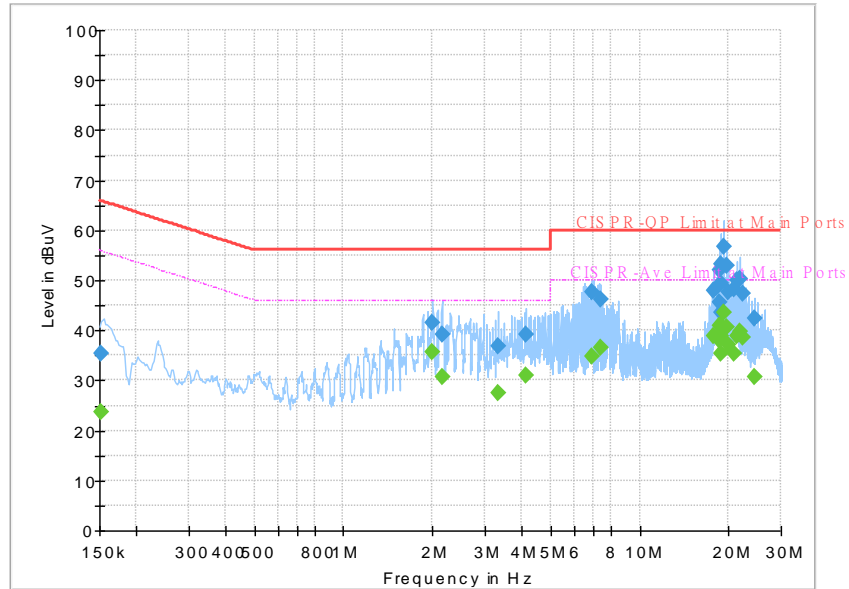

Final Result

Frequency (MHz)	QuasiPeak (dBuV)	CAverage (dBuV)	Limit (dBuV)	Margin (dB)	Line	Filter	Corr. (dB)
0.152250	---	23.54	55.88	32.34	L1	OFF	19.5
0.152250	35.26	---	65.88	30.62	L1	OFF	19.5
1.999500	---	35.58	46.00	10.42	L1	OFF	19.6
1.999500	41.39	---	56.00	14.61	L1	OFF	19.6
2.145750	---	30.56	46.00	15.44	L1	OFF	19.4
2.145750	39.21	---	56.00	16.79	L1	OFF	19.4
3.331500	---	27.60	46.00	18.40	L1	OFF	19.6
3.331500	36.71	---	56.00	19.29	L1	OFF	19.6
4.146000	---	31.08	46.00	14.92	L1	OFF	19.6
4.146000	39.11	---	56.00	16.89	L1	OFF	19.6
6.886500	---	34.94	50.00	15.06	L1	OFF	19.6
6.886500	47.66	---	60.00	12.34	L1	OFF	19.6
7.404000	---	36.57	50.00	13.43	L1	OFF	19.7
7.404000	46.34	---	60.00	13.66	L1	OFF	19.7
17.697750	---	38.81	50.00	11.19	L1	OFF	19.8
17.697750	47.85	---	60.00	12.15	L1	OFF	19.8
18.584250	---	38.10	50.00	11.90	L1	OFF	19.8
18.584250	45.74	---	60.00	14.26	L1	OFF	19.8
18.658500	---	40.79	50.00	9.21	L1	OFF	19.8
18.658500	52.10	---	60.00	7.90	L1	OFF	19.8
18.732750	---	40.80	50.00	9.20	L1	OFF	19.8
18.732750	53.32	---	60.00	6.68	L1	OFF	19.8



Test Mode :	Mode 2	Temperature :	24~26°C
Test Engineer :	Jimmy Chang	Relative Humidity :	51~54%
Test Voltage :	120Vac / 60Hz	Phase :	Line
Test Mode :	RFID on + EUT (Digital Scanner) Scan + CBA-U30-S15ZBR (Data Link with PC)		

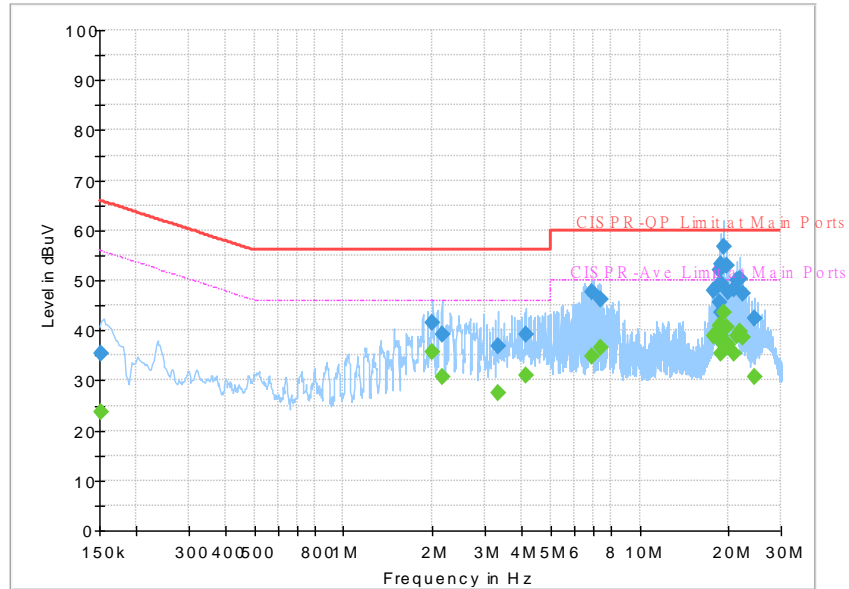

Final Result

Frequency (MHz)	QuasiPeak (dBuV)	CAverage (dBuV)	Limit (dBuV)	Margin (dB)	Line	Filter	Corr. (dB)
18.804750	---	38.90	50.00	11.10	L1	OFF	19.8
18.804750	49.42	---	60.00	10.58	L1	OFF	19.8
18.881250	---	35.31	50.00	14.69	L1	OFF	19.8
18.881250	43.44	---	60.00	16.56	L1	OFF	19.8
19.234500	---	43.53	50.00	6.47	L1	OFF	19.8
19.234500	56.84	---	60.00	3.16	L1	OFF	19.8
19.765500	---	40.75	50.00	9.25	L1	OFF	19.8
19.765500	52.99	---	60.00	7.01	L1	OFF	19.8
19.839750	---	37.05	50.00	12.95	L1	OFF	19.8
19.839750	47.69	---	60.00	12.31	L1	OFF	19.8
20.798250	---	35.42	50.00	14.58	L1	OFF	19.8
20.798250	48.29	---	60.00	11.71	L1	OFF	19.8
21.327000	---	38.87	50.00	11.13	L1	OFF	19.8
21.327000	49.90	---	60.00	10.10	L1	OFF	19.8
21.842250	---	39.76	50.00	10.24	L1	OFF	19.8
21.842250	50.42	---	60.00	9.58	L1	OFF	19.8
22.359750	---	38.56	50.00	11.44	L1	OFF	19.8
22.359750	47.29	---	60.00	12.71	L1	OFF	19.8
24.427500	---	30.72	50.00	19.28	L1	OFF	19.8
24.427500	42.53	---	60.00	17.47	L1	OFF	19.8



Test Mode :	Mode 2	Temperature :	24~26°C
Test Engineer :	Jimmy Chang	Relative Humidity :	51~54%
Test Voltage :	120Vac / 60Hz	Phase :	Neutral
Test Mode :	RFID on + EUT (Digital Scanner) Scan + CBA-U30-S15ZBR (Data Link with PC)		

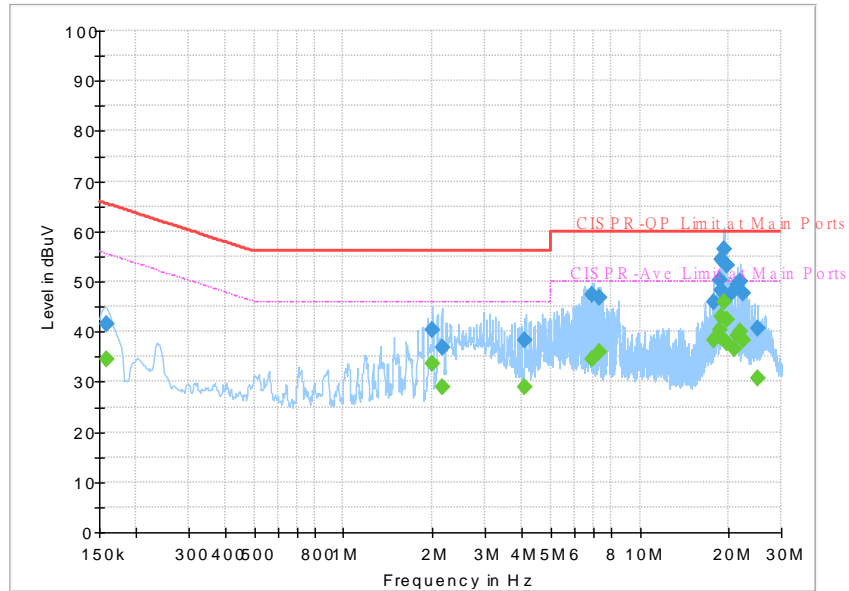

Final Result

Frequency (MHz)	QuasiPeak (dBuV)	CAverage (dBuV)	Limit (dBuV)	Margin (dB)	Line	Filter	Corr. (dB)
0.159000	---	34.47	55.52	21.05	N	OFF	19.5
0.159000	41.40	---	65.52	24.12	N	OFF	19.5
1.999500	---	33.68	46.00	12.32	N	OFF	19.6
1.999500	40.25	---	56.00	15.75	N	OFF	19.6
2.150250	---	28.91	46.00	17.09	N	OFF	19.4
2.150250	36.89	---	56.00	19.11	N	OFF	19.4
4.071750	---	29.09	46.00	16.91	N	OFF	19.6
4.071750	38.36	---	56.00	17.64	N	OFF	19.6
6.886500	---	34.61	50.00	15.39	N	OFF	19.6
6.886500	47.30	---	60.00	12.70	N	OFF	19.6
7.329750	---	35.82	50.00	14.18	N	OFF	19.7
7.329750	46.67	---	60.00	13.33	N	OFF	19.7
17.695500	---	38.41	50.00	11.59	N	OFF	19.8
17.695500	45.87	---	60.00	14.13	N	OFF	19.8
18.658500	---	40.24	50.00	9.76	N	OFF	19.9
18.658500	50.32	---	60.00	9.68	N	OFF	19.9
18.732750	---	43.09	50.00	6.91	N	OFF	19.9
18.732750	54.38	---	60.00	5.62	N	OFF	19.9
18.807000	---	38.91	50.00	11.09	N	OFF	19.9
18.807000	48.30	---	60.00	11.70	N	OFF	19.9
19.234500	---	45.90	50.00	4.10	N	OFF	19.9
19.234500	56.54	---	60.00	3.46	N	OFF	19.9



Test Mode :	Mode 2	Temperature :	24~26°C
Test Engineer :	Jimmy Chang	Relative Humidity :	51~54%
Test Voltage :	120Vac / 60Hz	Phase :	Neutral
Test Mode :	RFID on + EUT (Digital Scanner) Scan + CBA-U30-S15ZBR (Data Link with PC)		

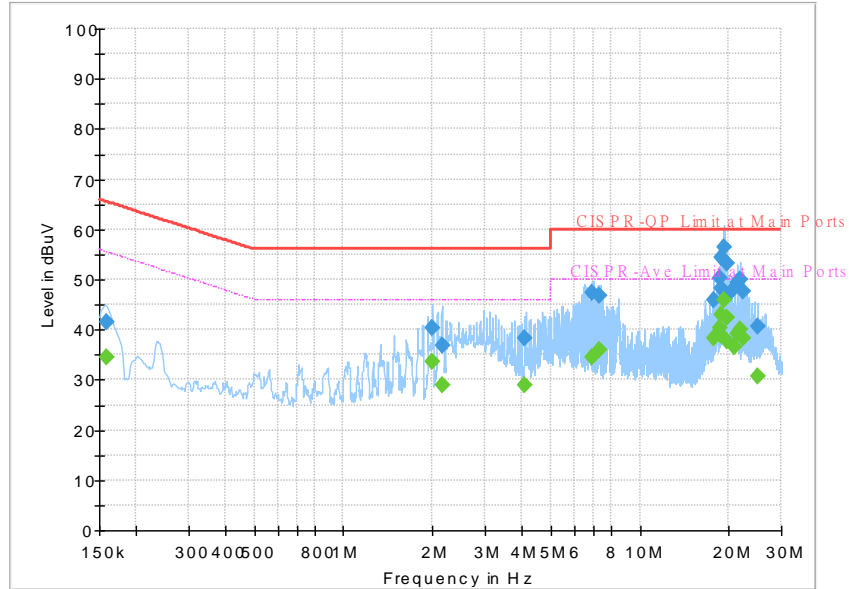

Final Result

Frequency (MHz)	QuasiPeak (dBuV)	CAverage (dBuV)	Limit (dBuV)	Margin (dB)	Line	Filter	Corr. (dB)
19.693500	---	37.60	50.00	12.40	N	OFF	19.9
19.693500	46.75	---	60.00	13.25	N	OFF	19.9
19.767750	---	42.38	50.00	7.62	N	OFF	19.9
19.767750	53.17	---	60.00	6.83	N	OFF	19.9
20.798250	---	36.56	50.00	13.44	N	OFF	19.9
20.798250	48.14	---	60.00	11.86	N	OFF	19.9
21.327000	---	39.22	50.00	10.78	N	OFF	19.9
21.327000	49.52	---	60.00	10.48	N	OFF	19.9
21.842250	---	40.05	50.00	9.95	N	OFF	19.9
21.842250	50.02	---	60.00	9.98	N	OFF	19.9
22.362000	---	38.39	50.00	11.61	N	OFF	19.9
22.362000	47.67	---	60.00	12.33	N	OFF	19.9
24.958500	---	30.77	50.00	19.23	N	OFF	20.0
24.958500	40.78	---	60.00	19.22	N	OFF	20.0



Appendix B. Radiated Spurious Emission

Test Engineer :	Stan Hsieh and Troye Hsieh	Temperature :	24~25°C
		Relative Humidity :	51~53%

902.3~927.75MHz

UHF (30MHz ~ 1GHz @ 3m)

ANT (Horizontal)

UHF	Note	Frequency	Level	Over	Limit	Read	Antenna	Cable	Preamp	Ant	Table	Peak	Pol.	
		(MHz)	(dBμV/m)	(dB)	Limit	Level	Factor	Loss	Factor	Pos	Pos	Avg.		
					Line	(dBμV)	(dB/m)	(dB)	(dB)	(cm)	(deg)	(P/A)	(H/V)	
902.3MHz		30	31	-9	40	35.39	24.6	1.19	30.18	-	-	P	H	
		130.71	36.31	-7.19	43.5	47.1	17.42	1.83	30.04	-	-	P	H	
		206.85	37.02	-6.48	43.5	49.75	15.05	2.18	29.96	100	0	P	H	
		700.4	39.22	-6.78	46	38.52	26.24	4.11	29.65	-	-	P	H	
		844.6	35.69	-10.31	46	31.72	28.63	4.48	29.14	-	-	P	H	
	*	902.3	116.77	70.77	46	112.22	28.76	4.68	28.89	-	-	P	H	
		948.2	34.53	-11.47	46	28.08	30.28	4.74	28.57	-	-	P	H	
													P	H
			30	31.94	-8.06	40	36.33	24.6	1.19	30.18	-	-	P	V
			65.37	33.01	-6.99	40	49.76	11.83	1.55	30.13	-	-	P	V
			205.23	36.63	-6.87	43.5	49.38	15.03	2.18	29.96	-	-	P	V
			383.3	38.19	-7.81	46	43.99	21.05	3.07	29.92	-	-	P	V
			895	41.66	-4.34	46	37.19	28.76	4.63	28.92	100	114	QP	V
	*	902.3	115.3	69.3	46	110.75	28.76	4.68	28.89	-	-	P	V	
			909.7	41.61	-4.39	46	36.83	28.93	4.68	28.83	100	83	QP	V
													P	V
Remark	1. No other spurious found. 2. All results are PASS against limit line.													



902.3~927.75MHz

UHF (1GHz ~ 10GHz @ 3m)

ANT (Horizontal)

UHF	Note	Frequency	Level	Over	Limit	Read	Antenna	Cable	Preamp	Ant	Table	Peak	Pol.
		(MHz)	(dBμV/m)	(dB)	Limit	Level	Factor	Loss	Factor	Pos	Pos	Avg.	
					Line	(dBμV)	(dB/m)	(dB)	(dB)	(cm)	(deg)	(P/A)	(H/V)
902.3MHz		2706.9	44.66	-29.34	74	63.3	32.6	8.16	59.4	-	-	P	H
		3609.2	45.16	-28.84	74	62.71	32.9	9.43	59.88	-	-	P	H
		4511.5	41.9	-32.1	74	57.53	33.87	10.47	59.97	-	-	P	H
		5413.8	43.46	-30.54	74	54.88	34.63	11.53	57.58	-	-	P	H
		8120.7	45.02	-28.98	74	53.03	35.73	14.24	57.98	-	-	P	H
		9023	45.25	-28.75	74	52.95	36.03	15.2	58.93	100	0	P	H
		2706.9	43.86	-30.14	74	62.5	32.6	8.16	59.4	-	-	P	V
		3609.2	43.69	-30.31	74	61.24	32.9	9.43	59.88	-	-	P	V
		4511.5	42.69	-31.31	74	58.32	33.87	10.47	59.97	-	-	P	V
		5413.8	44.36	-29.64	74	55.78	34.63	11.53	57.58	-	-	P	V
		8120.7	45.24	-28.76	74	53.25	35.73	14.24	57.98	100	0	P	V
		9023	45.2	-28.8	74	52.9	36.03	15.2	58.93	-	-	P	V
Remark	1. No other spurious found. 2. All results are PASS against Peak and Average limit line.												



902.3~927.75MHz

UHF (30MHz ~ 1GHz @ 3m)

ANT (Vertical)

UHF	Note	Frequency	Level	Over	Limit	Read	Antenna	Cable	Preamp	Ant	Table	Peak	Pol.	
				Limit	Line	Level	Factor	Loss	Factor	Pos	Pos	Avg.		
		(MHz)	(dB μ V/m)	(dB)	(dB μ V/m)	(dB μ V)	(dB/m)	(dB)	(dB)	(cm)	(deg)	(P/A)	(H/V)	
902.3MHz		30	31.33	-8.67	40	35.72	24.6	1.19	30.18	-	-	P	H	
		45.66	31.52	-8.48	40	44.19	16.3	1.19	30.16	-	-	P	H	
		159.06	37.35	-6.15	43.5	48.67	16.62	2.07	30.01	100	0	P	H	
		699	34.95	-11.05	46	34.31	26.24	4.05	29.65	-	-	P	H	
		739.6	36.58	-9.42	46	34.32	27.68	4.11	29.53	-	-	P	H	
	*	902.3	115.9	69.9	46	111.35	28.76	4.68	28.89	-	-	P	H	
		951	34.72	-11.28	46	28.14	30.39	4.74	28.55	-	-	P	H	
													P	H
													P	H
													P	H
													P	H
													P	H
													P	H
			30	31.66	-8.34	40	36.05	24.6	1.19	30.18	-	-	P	V
			68.34	33.64	-6.36	40	49.97	12.24	1.55	30.12	-	-	P	V
			205.5	37.42	-6.08	43.5	50.17	15.03	2.18	29.96	-	-	P	V
			834.1	36.66	-9.34	46	33.07	28.3	4.48	29.19	-	-	P	V
			895	42.52	-3.48	46	38.05	28.76	4.63	28.92	100	72	QP	V
	*		902.3	116.45	70.45	46	111.9	28.76	4.68	28.89	-	-	P	V
			909.7	42.4	-3.6	46	37.62	28.93	4.68	28.83	100	75	QP	V
													P	V
													P	V
												P	V	
												P	V	
												P	V	
												P	V	
Remark	1. No other spurious found. 2. All results are PASS against limit line.													



902.3~927.75MHz

UHF (1GHz ~ 10GHz @ 3m)

ANT (Vertical)

UHF	Note	Frequency	Level	Over	Limit	Read	Antenna	Cable	Preamp	Ant	Table	Peak	Pol.
		(MHz)	(dBμV/m)	(dB)	Limit	Level	Factor	Loss	Factor	Pos	Pos	Avg.	
					Line	(dBμV)	(dB/m)	(dB)	(dB)	(cm)	(deg)	(P/A)	(H/V)
902.3MHz		2706.9	45.4	-28.6	74	64.04	32.6	8.16	59.4	-	-	P	H
		3609.2	44.21	-29.79	74	61.76	32.9	9.43	59.88	-	-	P	H
		4511.5	42	-32	74	57.63	33.87	10.47	59.97	-	-	P	H
		5413.8	43.13	-30.87	74	54.55	34.63	11.53	57.58	-	-	P	H
		8120.7	45.16	-28.84	74	53.17	35.73	14.24	57.98	-	-	P	H
		9023	45.44	-28.56	74	53.14	36.03	15.2	58.93	100	0	P	H
		2706.9	44.57	-29.43	74	63.21	32.6	8.16	59.4	-	-	P	V
		3609.2	45.15	-28.85	74	62.7	32.9	9.43	59.88	-	-	P	V
		4511.5	41.78	-32.22	74	57.41	33.87	10.47	59.97	-	-	P	V
		5413.8	44.73	-29.27	74	56.15	34.63	11.53	57.58	-	-	P	V
		8120.7	45.17	-28.83	74	53.18	35.73	14.24	57.98	-	-	P	V
		9023	45.76	-28.24	74	53.46	36.03	15.2	58.93	100	0	P	V
Remark	1. No other spurious found. 2. All results are PASS against Peak and Average limit line.												



902.3~927.75MHz

UHF (30MHz ~ 1GHz @ 3m)

ANT (Vertical)

UHF	Note	Frequency	Level	Over	Limit	Read	Antenna	Cable	Preamp	Ant	Table	Peak	Pol.	
		(MHz)	(dBμV/m)	(dB)	Limit	Level	Factor	Loss	Factor	Pos	Pos	Avg.		
					Line	(dBμV)	(dB/m)	(dB)	(dB)	(cm)	(deg)	(P/A)	(H/V)	
914.5MHz		30	31.07	-8.93	40	35.46	24.6	1.19	30.18	-	-	P	H	
		204.15	36.56	-6.94	43.5	49.33	15.01	2.18	29.96	100	0	P	H	
		245.46	38.95	-7.05	46	48.68	17.8	2.42	29.95	-	-	P	H	
		668.9	35.78	-10.22	46	35.23	26.21	4.05	29.71	-	-	P	H	
		809.6	34.21	-11.79	46	31.31	27.87	4.33	29.3	-	-	P	H	
	*	914.5	115.83	69.83	46	110.91	29.04	4.68	28.8	-	-	P	H	
		949.6	34.02	-11.98	46	27.51	30.33	4.74	28.56	-	-	P	H	
													P	H
													P	H
													P	H
													P	H
													P	H
													P	H
			30.27	31.74	-8.26	40	36.13	24.6	1.19	30.18	-	-	P	V
			68.61	33.82	-6.18	40	50.15	12.24	1.55	30.12	-	-	P	V
			206.58	33.52	-9.98	43.5	46.25	15.05	2.18	29.96	-	-	P	V
			845.3	38.78	-7.22	46	34.78	28.66	4.48	29.14	-	-	P	V
			906.9	42.81	-3.19	46	38.11	28.87	4.68	28.85	100	326	QP	V
	*		914.5	117.02	71.02	46	112.1	29.04	4.68	28.8	-	-	P	V
			921.6	42.67	-3.33	46	37.54	29.2	4.68	28.75	100	330	QP	V
												P	V	
												P	V	
												P	V	
												P	V	
												P	V	
Remark	1. No other spurious found. 2. All results are PASS against limit line.													



902.3~927.75MHz

UHF (1GHz ~ 10GHz @ 3m)

ANT (Vertical)

UHF	Note	Frequency	Level	Over	Limit	Read	Antenna	Cable	Preamp	Ant	Table	Peak	Pol.
				Limit	Line	Level	Factor	Loss	Factor	Pos	Pos	Avg.	
		(MHz)	(dBμV/m)	(dB)	(dBμV/m)	(dBμV)	(dB/m)	(dB)	(dB)	(cm)	(deg)	(P/A)	(H/V)
914.5MHz		2743.5	53.05	-20.95	74	71.73	32.5	8.22	59.4	100	0	P	H
		3658	50.37	-23.63	74	67.91	32.9	9.48	59.92	-	-	P	H
		4572.5	42.39	-31.61	74	57.74	34	10.51	59.86	-	-	P	H
		7316	40.51	-33.49	74	49.54	35.63	13.5	58.16	-	-	P	H
		8230.5	36.72	-37.28	74	44.53	35.8	14.35	57.96	-	-	P	H
		9145	35.13	-38.87	74	42.86	36.1	15.35	59.18	-	-	P	H
		2743.5	51.95	-22.05	74	70.63	32.5	8.22	59.4	100	0	P	V
		3658	49.47	-24.53	74	67.01	32.9	9.48	59.92	-	-	P	V
		4572.5	43.14	-30.86	74	58.49	34	10.51	59.86	-	-	P	V
		7316	39.8	-34.2	74	48.83	35.63	13.5	58.16	-	-	P	V
		8230.5	36.23	-37.77	74	44.04	35.8	14.35	57.96	-	-	P	V
		9145	34.56	-39.44	74	42.29	36.1	15.35	59.18	-	-	P	V
Remark	1. No other spurious found. 2. All results are PASS against Peak and Average limit line.												



902.3~927.75MHz

UHF (30MHz ~ 1GHz @ 3m)

ANT (Vertical)

UHF	Note	Frequency	Level	Over	Limit	Read	Antenna	Cable	Preamp	Ant	Table	Peak	Pol.	
		(MHz)	(dBμV/m)	(dB)	Limit	Level	Factor	Loss	Factor	Pos	Pos	Avg.		
					Line	(dBμV)	(dB/m)	(dB)	(dB)	(cm)	(deg)	(P/A)	(H/V)	
927.75MHz		159.33	36.61	-6.89	43.5	47.93	16.62	2.07	30.01	-	-	P	H	
		204.96	36.94	-6.56	43.5	49.71	15.01	2.18	29.96	100	0	P	H	
		244.65	38.24	-7.76	46	48.09	17.68	2.42	29.95	-	-	P	H	
		685.7	35.03	-10.97	46	34.41	26.25	4.05	29.68	-	-	P	H	
		762	34.09	-11.91	46	31.52	27.85	4.18	29.46	-	-	P	H	
	*	927.75	114.72	68.72	46	109.32	29.43	4.68	28.71	-	-	P	H	
		954.5	34.48	-11.52	46	27.68	30.59	4.74	28.53	-	-	P	H	
													P	H
													P	H
													P	H
													P	H
													P	H
													P	H
			30	32.04	-7.96	40	36.43	24.6	1.19	30.18	-	-	P	V
			70.5	33.01	-6.99	40	49.16	12.42	1.55	30.12	-	-	P	V
			209.28	33.23	-10.27	43.5	45.9	15.11	2.18	29.96	-	-	P	V
			859.3	38.82	-7.18	46	34.41	29.01	4.48	29.08	-	-	P	V
			920.2	42.46	-3.54	46	37.38	29.17	4.68	28.77	100	335	QP	V
	*		927.75	117.36	71.36	46	111.96	29.43	4.68	28.71	-	-	P	V
			934.9	42.56	-3.44	46	36.88	29.66	4.68	28.66	100	332	QP	V
												P	V	
												P	V	
												P	V	
												P	V	
												P	V	
Remark	1. No other spurious found. 2. All results are PASS against limit line.													



902.3~927.75MHz

UHF (1GHz ~ 10GHz @ 3m)

ANT (Vertical)

UHF	Note	Frequency	Level	Over	Limit	Read	Antenna	Cable	Preamp	Ant	Table	Peak	Pol.
		(MHz)	(dBμV/m)	(dB)	Limit	Level	Factor	Loss	Factor	Pos	Pos	Avg.	
					Line	(dBμV)	(dB/m)	(dB)	(dB)	(cm)	(deg)	(P/A)	(H/V)
927.75MHz		2783.25	53.42	-20.58	74	72.11	32.43	8.28	59.4	100	0	P	H
		3711	49.55	-24.45	74	66.94	33	9.58	59.97	-	-	P	H
		4638.75	42.19	-31.81	74	57.22	34.07	10.62	59.72	-	-	P	H
		7422	39.15	-34.85	74	48.33	35.5	13.62	58.3	-	-	P	H
		8349.75	36.14	-37.86	74	43.98	35.6	14.49	57.93	-	-	P	H
		9277.5	34.17	-39.83	74	42.04	36.07	15.51	59.45	-	-	P	H
		2783.25	54.45	-19.55	74	73.14	32.43	8.28	59.4	100	0	P	V
		3711	47.18	-26.82	74	64.57	33	9.58	59.97	-	-	P	V
		4638.75	42.08	-31.92	74	57.11	34.07	10.62	59.72	-	-	P	V
		7422	37.61	-36.39	74	46.79	35.5	13.62	58.3	-	-	P	V
		8349.75	34.53	-39.47	74	42.37	35.6	14.49	57.93	-	-	P	V
		9277.5	33.31	-40.69	74	41.18	36.07	15.51	59.45	-	-	P	V
Remark	1. No other spurious found. 2. All results are PASS against Peak and Average limit line.												



Note symbol

*	Fundamental Frequency which can be ignored. However, the level of any unwanted emissions shall not exceed the level of the fundamental frequency.
!	Test result is over limit line.
QP/P/A	Quasi Peak or Peak or Average
H/V	H orizontal or V ertical



A calculation example for radiated spurious emission is shown as below:

WIFI	Note	Frequency	Level	Over	Limit	Read	Antenna	Cable	Preamp	Ant	Table	Peak	Pol.
Ant.				Limit	Line	Level	Factor	Loss	Factor	Pos	Pos	Avg.	
1+2		(MHz)	(dBμV/m)	(dB)	(dBμV/m)	(dBμV)	(dB/m)	(dB)	(dB)	(cm)	(deg)	(P/A)	(H/V)
802.11b		2390	55.45	-18.55	74	54.51	32.22	4.58	35.86	103	308	P	H
CH 01													
2412MHz		2390	43.54	-10.46	54	42.6	32.22	4.58	35.86	103	308	A	H

- Level(dBμV/m) =
Antenna Factor(dB/m) + Cable Loss(dB) + Read Level(dBμV) - Preamp Factor(dB)
- Over Limit(dB) = Level(dBμV/m) – Limit Line(dBμV/m)

For Peak Limit @ 2390MHz:

- Level(dBμV/m)
= Antenna Factor(dB/m) + Cable Loss(dB) + Read Level(dBμV) - Preamp Factor(dB)
= 32.22(dB/m) + 4.58(dB) + 54.51(dBμV) – 35.86 (dB)
= 55.45 (dBμV/m)
- Over Limit(dB)
= Level(dBμV/m) – Limit Line(dBμV/m)
= 55.45(dBμV/m) – 74(dBμV/m)
= -18.55(dB)

For Average Limit @ 2390MHz:

- Level(dBμV/m)
= Antenna Factor(dB/m) + Cable Loss(dB) + Read Level(dBμV) - Preamp Factor(dB)
= 32.22(dB/m) + 4.58(dB) + 42.6(dBμV) – 35.86 (dB)
= 43.54 (dBμV/m)
- Over Limit(dB)
= Level(dBμV/m) – Limit Line(dBμV/m)
= 43.54(dBμV/m) – 54(dBμV/m)
= -10.46(dB)

Both peak and average measured complies with the limit line, so test result is “PASS”.



Appendix C. Radiated Spurious Emission Plots

Test Engineer :	Stan Hsieh, and Troye Hsieh	Temperature :	24~25°C
		Relative Humidity :	51~53%

902.3~927.75MHz

UHF (30MHz ~ 1GHz @ 3m)

ANT (Horizontal)

UHF	902.3~927.75MHz UHF (30MHz ~ 1GHz @ 3m)																																																																																																																																																																																																							
	UHF 902.3 MHz																																																																																																																																																																																																							
	Horizontal	Vertical																																																																																																																																																																																																						
QP / Peak	<p>Site : 03CH07-HY Condition : QP 3m LF-ANT-35419(6) HORIZONTAL Project : 921127 Mode : 1</p> <table border="1"> <thead> <tr> <th>Frq</th> <th>Level</th> <th>Limit</th> <th>Over</th> <th>Limit</th> <th>ReadAntenna</th> <th>Cable</th> <th>Preamp</th> <th>A/Pos</th> <th>T/Pos</th> <th>Remark</th> </tr> <tr> <th>MHz</th> <th>dBuV/m</th> <th>dB</th> <th>dBuV/m</th> <th>dBuV/m</th> <th>dB/m</th> <th>dB</th> <th>dB</th> <th>cm</th> <th>deg</th> <th></th> </tr> </thead> <tbody> <tr> <td>1</td> <td>30.00</td> <td>31.00</td> <td>-9.00</td> <td>40.00</td> <td>35.39</td> <td>24.60</td> <td>1.19</td> <td>30.18</td> <td>---</td> <td>Peak</td> </tr> <tr> <td>2</td> <td>130.71</td> <td>36.31</td> <td>-7.19</td> <td>43.50</td> <td>47.10</td> <td>17.42</td> <td>1.83</td> <td>30.84</td> <td>---</td> <td>Peak</td> </tr> <tr> <td>3</td> <td>206.65</td> <td>37.02</td> <td>-6.48</td> <td>43.50</td> <td>49.75</td> <td>15.85</td> <td>2.18</td> <td>29.96</td> <td>100</td> <td>0 Peak</td> </tr> <tr> <td>4</td> <td>700.40</td> <td>39.22</td> <td>-6.78</td> <td>46.00</td> <td>38.52</td> <td>26.24</td> <td>4.11</td> <td>29.65</td> <td>---</td> <td>Peak</td> </tr> <tr> <td>5</td> <td>844.60</td> <td>35.69</td> <td>-10.31</td> <td>46.00</td> <td>31.72</td> <td>28.63</td> <td>4.46</td> <td>29.14</td> <td>---</td> <td>Peak</td> </tr> <tr> <td>6</td> <td>902.30</td> <td>116.77</td> <td>70.77</td> <td>46.00</td> <td>112.22</td> <td>28.76</td> <td>4.68</td> <td>28.89</td> <td>---</td> <td>Peak</td> </tr> <tr> <td>7</td> <td>940.20</td> <td>34.53</td> <td>-11.47</td> <td>46.00</td> <td>28.00</td> <td>30.28</td> <td>4.74</td> <td>28.57</td> <td>---</td> <td>Peak</td> </tr> </tbody> </table>	Frq	Level	Limit	Over	Limit	ReadAntenna	Cable	Preamp	A/Pos	T/Pos	Remark	MHz	dBuV/m	dB	dBuV/m	dBuV/m	dB/m	dB	dB	cm	deg		1	30.00	31.00	-9.00	40.00	35.39	24.60	1.19	30.18	---	Peak	2	130.71	36.31	-7.19	43.50	47.10	17.42	1.83	30.84	---	Peak	3	206.65	37.02	-6.48	43.50	49.75	15.85	2.18	29.96	100	0 Peak	4	700.40	39.22	-6.78	46.00	38.52	26.24	4.11	29.65	---	Peak	5	844.60	35.69	-10.31	46.00	31.72	28.63	4.46	29.14	---	Peak	6	902.30	116.77	70.77	46.00	112.22	28.76	4.68	28.89	---	Peak	7	940.20	34.53	-11.47	46.00	28.00	30.28	4.74	28.57	---	Peak	<p>Site : 03CH07-HY Condition : QP 3m LF-ANT-35419(6) VERTICAL Project : 921127 Mode : 1</p> <table border="1"> <thead> <tr> <th>Frq</th> <th>Level</th> <th>Limit</th> <th>Over</th> <th>Limit</th> <th>ReadAntenna</th> <th>Cable</th> <th>Preamp</th> <th>A/Pos</th> <th>T/Pos</th> <th>Remark</th> </tr> <tr> <th>MHz</th> <th>dBuV/m</th> <th>dB</th> <th>dBuV/m</th> <th>dBuV/m</th> <th>dB/m</th> <th>dB</th> <th>dB</th> <th>cm</th> <th>deg</th> <th></th> </tr> </thead> <tbody> <tr> <td>1</td> <td>30.00</td> <td>31.94</td> <td>-8.06</td> <td>40.00</td> <td>36.33</td> <td>24.60</td> <td>1.19</td> <td>30.18</td> <td>---</td> <td>Peak</td> </tr> <tr> <td>2</td> <td>65.37</td> <td>33.01</td> <td>-6.99</td> <td>40.00</td> <td>49.76</td> <td>11.83</td> <td>1.55</td> <td>30.13</td> <td>---</td> <td>Peak</td> </tr> <tr> <td>3</td> <td>205.23</td> <td>36.63</td> <td>-6.87</td> <td>43.50</td> <td>49.38</td> <td>15.83</td> <td>2.18</td> <td>29.96</td> <td>---</td> <td>Peak</td> </tr> <tr> <td>4</td> <td>383.30</td> <td>38.19</td> <td>-7.81</td> <td>46.00</td> <td>43.99</td> <td>21.05</td> <td>3.07</td> <td>29.92</td> <td>---</td> <td>Peak</td> </tr> <tr> <td>5</td> <td>895.00</td> <td>41.66</td> <td>-4.34</td> <td>46.00</td> <td>37.19</td> <td>28.76</td> <td>4.63</td> <td>28.92</td> <td>100</td> <td>114 QP</td> </tr> <tr> <td>6</td> <td>902.30</td> <td>115.30</td> <td>69.30</td> <td>46.00</td> <td>110.75</td> <td>28.76</td> <td>4.68</td> <td>28.89</td> <td>---</td> <td>Peak</td> </tr> <tr> <td>7</td> <td>909.70</td> <td>41.61</td> <td>-4.39</td> <td>46.00</td> <td>36.83</td> <td>28.93</td> <td>4.68</td> <td>28.83</td> <td>100</td> <td>83 QP</td> </tr> </tbody> </table>	Frq	Level	Limit	Over	Limit	ReadAntenna	Cable	Preamp	A/Pos	T/Pos	Remark	MHz	dBuV/m	dB	dBuV/m	dBuV/m	dB/m	dB	dB	cm	deg		1	30.00	31.94	-8.06	40.00	36.33	24.60	1.19	30.18	---	Peak	2	65.37	33.01	-6.99	40.00	49.76	11.83	1.55	30.13	---	Peak	3	205.23	36.63	-6.87	43.50	49.38	15.83	2.18	29.96	---	Peak	4	383.30	38.19	-7.81	46.00	43.99	21.05	3.07	29.92	---	Peak	5	895.00	41.66	-4.34	46.00	37.19	28.76	4.63	28.92	100	114 QP	6	902.30	115.30	69.30	46.00	110.75	28.76	4.68	28.89	---	Peak	7	909.70	41.61	-4.39	46.00	36.83	28.93	4.68	28.83	100	83 QP
	Frq	Level	Limit	Over	Limit	ReadAntenna	Cable	Preamp	A/Pos	T/Pos	Remark																																																																																																																																																																																													
MHz	dBuV/m	dB	dBuV/m	dBuV/m	dB/m	dB	dB	cm	deg																																																																																																																																																																																															
1	30.00	31.00	-9.00	40.00	35.39	24.60	1.19	30.18	---	Peak																																																																																																																																																																																														
2	130.71	36.31	-7.19	43.50	47.10	17.42	1.83	30.84	---	Peak																																																																																																																																																																																														
3	206.65	37.02	-6.48	43.50	49.75	15.85	2.18	29.96	100	0 Peak																																																																																																																																																																																														
4	700.40	39.22	-6.78	46.00	38.52	26.24	4.11	29.65	---	Peak																																																																																																																																																																																														
5	844.60	35.69	-10.31	46.00	31.72	28.63	4.46	29.14	---	Peak																																																																																																																																																																																														
6	902.30	116.77	70.77	46.00	112.22	28.76	4.68	28.89	---	Peak																																																																																																																																																																																														
7	940.20	34.53	-11.47	46.00	28.00	30.28	4.74	28.57	---	Peak																																																																																																																																																																																														
Frq	Level	Limit	Over	Limit	ReadAntenna	Cable	Preamp	A/Pos	T/Pos	Remark																																																																																																																																																																																														
MHz	dBuV/m	dB	dBuV/m	dBuV/m	dB/m	dB	dB	cm	deg																																																																																																																																																																																															
1	30.00	31.94	-8.06	40.00	36.33	24.60	1.19	30.18	---	Peak																																																																																																																																																																																														
2	65.37	33.01	-6.99	40.00	49.76	11.83	1.55	30.13	---	Peak																																																																																																																																																																																														
3	205.23	36.63	-6.87	43.50	49.38	15.83	2.18	29.96	---	Peak																																																																																																																																																																																														
4	383.30	38.19	-7.81	46.00	43.99	21.05	3.07	29.92	---	Peak																																																																																																																																																																																														
5	895.00	41.66	-4.34	46.00	37.19	28.76	4.63	28.92	100	114 QP																																																																																																																																																																																														
6	902.30	115.30	69.30	46.00	110.75	28.76	4.68	28.89	---	Peak																																																																																																																																																																																														
7	909.70	41.61	-4.39	46.00	36.83	28.93	4.68	28.83	100	83 QP																																																																																																																																																																																														



902.3~927.75MHz

UHF (1GHz ~ 10GHz @ 3m)

ANT (Horizontal)

UHF	902.3~927.5MHz UHF (1GHz ~ 10GHz @ 3m)																																																																																																																																																																																	
	UHF 902.3 MHz																																																																																																																																																																																	
	Horizontal	Vertical																																																																																																																																																																																
Peak Avg.	<p>Site : 03CH07-HY Condition : PEAK_74 3m HF_ANT_00075962 HORIZONTAL Project : 921127 Mode : 1</p> <table border="1"> <thead> <tr> <th>Peak</th> <th>Freq</th> <th>Level</th> <th>Over</th> <th>Limit</th> <th>ReadAntenna</th> <th>Cable</th> <th>Preamp</th> <th>A/Pos</th> <th>T/Pos</th> <th>Remark</th> </tr> <tr> <th></th> <th>MHz</th> <th>dBuV/m</th> <th>dB</th> <th>dBuV/m</th> <th>dBuV</th> <th>dB/m</th> <th>dB</th> <th>dB</th> <th>cm</th> <th>deg</th> </tr> </thead> <tbody> <tr> <td>1</td> <td>2786.90</td> <td>44.66</td> <td>-29.34</td> <td>74.00</td> <td>63.30</td> <td>32.60</td> <td>8.16</td> <td>59.40</td> <td>---</td> <td>Peak</td> </tr> <tr> <td>2</td> <td>3689.28</td> <td>45.16</td> <td>-28.84</td> <td>74.00</td> <td>62.71</td> <td>32.90</td> <td>9.43</td> <td>59.88</td> <td>---</td> <td>Peak</td> </tr> <tr> <td>3</td> <td>4511.58</td> <td>41.98</td> <td>-32.02</td> <td>74.00</td> <td>57.53</td> <td>33.87</td> <td>18.47</td> <td>59.97</td> <td>---</td> <td>Peak</td> </tr> <tr> <td>4</td> <td>5413.88</td> <td>43.46</td> <td>-30.54</td> <td>74.00</td> <td>54.88</td> <td>34.63</td> <td>11.53</td> <td>57.58</td> <td>---</td> <td>Peak</td> </tr> <tr> <td>5</td> <td>8128.78</td> <td>45.02</td> <td>-28.98</td> <td>74.00</td> <td>53.03</td> <td>35.73</td> <td>14.24</td> <td>57.98</td> <td>---</td> <td>Peak</td> </tr> <tr> <td>6</td> <td>9023.88</td> <td>45.25</td> <td>-28.75</td> <td>74.00</td> <td>52.95</td> <td>36.83</td> <td>15.20</td> <td>58.93</td> <td>100</td> <td>Peak</td> </tr> </tbody> </table>	Peak	Freq	Level	Over	Limit	ReadAntenna	Cable	Preamp	A/Pos	T/Pos	Remark		MHz	dBuV/m	dB	dBuV/m	dBuV	dB/m	dB	dB	cm	deg	1	2786.90	44.66	-29.34	74.00	63.30	32.60	8.16	59.40	---	Peak	2	3689.28	45.16	-28.84	74.00	62.71	32.90	9.43	59.88	---	Peak	3	4511.58	41.98	-32.02	74.00	57.53	33.87	18.47	59.97	---	Peak	4	5413.88	43.46	-30.54	74.00	54.88	34.63	11.53	57.58	---	Peak	5	8128.78	45.02	-28.98	74.00	53.03	35.73	14.24	57.98	---	Peak	6	9023.88	45.25	-28.75	74.00	52.95	36.83	15.20	58.93	100	Peak	<p>Site : 03CH07-HY Condition : PEAK_74 3m HF_ANT_00075962 VERTICAL Project : 921127 Mode : 1</p> <table border="1"> <thead> <tr> <th>Peak</th> <th>Freq</th> <th>Level</th> <th>Over</th> <th>Limit</th> <th>ReadAntenna</th> <th>Cable</th> <th>Preamp</th> <th>A/Pos</th> <th>T/Pos</th> <th>Remark</th> </tr> <tr> <th></th> <th>MHz</th> <th>dBuV/m</th> <th>dB</th> <th>dBuV/m</th> <th>dBuV</th> <th>dB/m</th> <th>dB</th> <th>dB</th> <th>cm</th> <th>deg</th> </tr> </thead> <tbody> <tr> <td>1</td> <td>2786.90</td> <td>43.86</td> <td>-30.14</td> <td>74.00</td> <td>62.58</td> <td>32.60</td> <td>8.16</td> <td>59.40</td> <td>---</td> <td>Peak</td> </tr> <tr> <td>2</td> <td>3689.28</td> <td>43.69</td> <td>-30.31</td> <td>74.00</td> <td>61.24</td> <td>32.90</td> <td>9.43</td> <td>59.88</td> <td>---</td> <td>Peak</td> </tr> <tr> <td>3</td> <td>4511.58</td> <td>42.69</td> <td>-31.31</td> <td>74.00</td> <td>58.32</td> <td>33.87</td> <td>18.47</td> <td>59.97</td> <td>---</td> <td>Peak</td> </tr> <tr> <td>4</td> <td>5413.88</td> <td>44.36</td> <td>-29.64</td> <td>74.00</td> <td>55.78</td> <td>34.63</td> <td>11.53</td> <td>57.58</td> <td>---</td> <td>Peak</td> </tr> <tr> <td>5</td> <td>8128.78</td> <td>45.24</td> <td>-28.76</td> <td>74.00</td> <td>53.25</td> <td>35.73</td> <td>14.24</td> <td>57.98</td> <td>100</td> <td>Peak</td> </tr> <tr> <td>6</td> <td>9023.88</td> <td>45.20</td> <td>-28.80</td> <td>74.00</td> <td>52.90</td> <td>36.83</td> <td>15.20</td> <td>58.93</td> <td>---</td> <td>Peak</td> </tr> </tbody> </table>	Peak	Freq	Level	Over	Limit	ReadAntenna	Cable	Preamp	A/Pos	T/Pos	Remark		MHz	dBuV/m	dB	dBuV/m	dBuV	dB/m	dB	dB	cm	deg	1	2786.90	43.86	-30.14	74.00	62.58	32.60	8.16	59.40	---	Peak	2	3689.28	43.69	-30.31	74.00	61.24	32.90	9.43	59.88	---	Peak	3	4511.58	42.69	-31.31	74.00	58.32	33.87	18.47	59.97	---	Peak	4	5413.88	44.36	-29.64	74.00	55.78	34.63	11.53	57.58	---	Peak	5	8128.78	45.24	-28.76	74.00	53.25	35.73	14.24	57.98	100	Peak	6	9023.88	45.20	-28.80	74.00	52.90	36.83	15.20	58.93	---	Peak
	Peak	Freq	Level	Over	Limit	ReadAntenna	Cable	Preamp	A/Pos	T/Pos	Remark																																																																																																																																																																							
	MHz	dBuV/m	dB	dBuV/m	dBuV	dB/m	dB	dB	cm	deg																																																																																																																																																																								
1	2786.90	44.66	-29.34	74.00	63.30	32.60	8.16	59.40	---	Peak																																																																																																																																																																								
2	3689.28	45.16	-28.84	74.00	62.71	32.90	9.43	59.88	---	Peak																																																																																																																																																																								
3	4511.58	41.98	-32.02	74.00	57.53	33.87	18.47	59.97	---	Peak																																																																																																																																																																								
4	5413.88	43.46	-30.54	74.00	54.88	34.63	11.53	57.58	---	Peak																																																																																																																																																																								
5	8128.78	45.02	-28.98	74.00	53.03	35.73	14.24	57.98	---	Peak																																																																																																																																																																								
6	9023.88	45.25	-28.75	74.00	52.95	36.83	15.20	58.93	100	Peak																																																																																																																																																																								
Peak	Freq	Level	Over	Limit	ReadAntenna	Cable	Preamp	A/Pos	T/Pos	Remark																																																																																																																																																																								
	MHz	dBuV/m	dB	dBuV/m	dBuV	dB/m	dB	dB	cm	deg																																																																																																																																																																								
1	2786.90	43.86	-30.14	74.00	62.58	32.60	8.16	59.40	---	Peak																																																																																																																																																																								
2	3689.28	43.69	-30.31	74.00	61.24	32.90	9.43	59.88	---	Peak																																																																																																																																																																								
3	4511.58	42.69	-31.31	74.00	58.32	33.87	18.47	59.97	---	Peak																																																																																																																																																																								
4	5413.88	44.36	-29.64	74.00	55.78	34.63	11.53	57.58	---	Peak																																																																																																																																																																								
5	8128.78	45.24	-28.76	74.00	53.25	35.73	14.24	57.98	100	Peak																																																																																																																																																																								
6	9023.88	45.20	-28.80	74.00	52.90	36.83	15.20	58.93	---	Peak																																																																																																																																																																								



902.3~927.75MHz

UHF (30MHz ~ 1GHz @ 3m)

ANT (Vertical)

UHF	902.3~927.75MHz UHF (30MHz ~ 1GHz @ 3m)																																																																																																																																																																																																	
	UHF 902.3 MHz																																																																																																																																																																																																	
	Horizontal	Vertical																																																																																																																																																																																																
QP / Peak	<p>Date: 2019-04-10</p> <p>Site : 03CH07-HY Condition : QP 3m LF-ANT-35419(6) HORIZONTAL Project : 921127 Mode : 12</p> <table border="1"> <thead> <tr> <th>Peak</th> <th>Freq (MHz)</th> <th>Level (dBuV/m)</th> <th>Over Limit (dB)</th> <th>Limit Line (dBuV/m)</th> <th>ReadAntenna Level (dBuV)</th> <th>Antenna Factor (dB/m)</th> <th>Cable Loss (dB)</th> <th>Preamp Loss (dB)</th> <th>A/Pos (cm)</th> <th>T/Pos (deg)</th> <th>Remark</th> </tr> </thead> <tbody> <tr><td>1</td><td>30.00</td><td>31.33</td><td>-8.67</td><td>40.00</td><td>35.72</td><td>24.60</td><td>1.19</td><td>30.18</td><td>---</td><td>---</td><td>Peak</td></tr> <tr><td>2</td><td>45.66</td><td>31.52</td><td>-8.48</td><td>40.00</td><td>44.19</td><td>16.30</td><td>1.19</td><td>30.16</td><td>---</td><td>---</td><td>Peak</td></tr> <tr><td>3</td><td>159.05</td><td>37.35</td><td>-6.15</td><td>43.50</td><td>45.67</td><td>16.62</td><td>2.07</td><td>30.01</td><td>100</td><td>0</td><td>Peak</td></tr> <tr><td>4</td><td>699.00</td><td>34.95</td><td>-11.05</td><td>46.00</td><td>34.31</td><td>26.24</td><td>4.05</td><td>29.65</td><td>---</td><td>---</td><td>Peak</td></tr> <tr><td>5</td><td>739.60</td><td>36.50</td><td>-9.42</td><td>46.00</td><td>34.32</td><td>27.68</td><td>4.11</td><td>29.53</td><td>---</td><td>---</td><td>Peak</td></tr> <tr><td>6</td><td>902.30</td><td>115.90</td><td>69.90</td><td>46.00</td><td>111.35</td><td>28.76</td><td>4.68</td><td>28.89</td><td>---</td><td>---</td><td>Peak</td></tr> <tr><td>7</td><td>951.00</td><td>34.72</td><td>-11.28</td><td>46.00</td><td>28.14</td><td>30.39</td><td>4.74</td><td>28.55</td><td>---</td><td>---</td><td>Peak</td></tr> </tbody> </table>	Peak	Freq (MHz)	Level (dBuV/m)	Over Limit (dB)	Limit Line (dBuV/m)	ReadAntenna Level (dBuV)	Antenna Factor (dB/m)	Cable Loss (dB)	Preamp Loss (dB)	A/Pos (cm)	T/Pos (deg)	Remark	1	30.00	31.33	-8.67	40.00	35.72	24.60	1.19	30.18	---	---	Peak	2	45.66	31.52	-8.48	40.00	44.19	16.30	1.19	30.16	---	---	Peak	3	159.05	37.35	-6.15	43.50	45.67	16.62	2.07	30.01	100	0	Peak	4	699.00	34.95	-11.05	46.00	34.31	26.24	4.05	29.65	---	---	Peak	5	739.60	36.50	-9.42	46.00	34.32	27.68	4.11	29.53	---	---	Peak	6	902.30	115.90	69.90	46.00	111.35	28.76	4.68	28.89	---	---	Peak	7	951.00	34.72	-11.28	46.00	28.14	30.39	4.74	28.55	---	---	Peak	<p>Date: 2019-04-10</p> <p>Site : 03CH07-HY Condition : QP 3m LF-ANT-35419(6) VERTICAL Project : 921127 Mode : 12</p> <table border="1"> <thead> <tr> <th>Peak</th> <th>Freq (MHz)</th> <th>Level (dBuV/m)</th> <th>Over Limit (dB)</th> <th>Limit Line (dBuV/m)</th> <th>ReadAntenna Level (dBuV)</th> <th>Antenna Factor (dB/m)</th> <th>Cable Loss (dB)</th> <th>Preamp Loss (dB)</th> <th>A/Pos (cm)</th> <th>T/Pos (deg)</th> <th>Remark</th> </tr> </thead> <tbody> <tr><td>1</td><td>30.00</td><td>31.66</td><td>-8.34</td><td>40.00</td><td>36.05</td><td>24.60</td><td>1.19</td><td>30.18</td><td>---</td><td>---</td><td>Peak</td></tr> <tr><td>2</td><td>68.34</td><td>33.64</td><td>-6.36</td><td>40.00</td><td>49.97</td><td>12.24</td><td>1.55</td><td>30.12</td><td>---</td><td>---</td><td>Peak</td></tr> <tr><td>3</td><td>205.50</td><td>37.42</td><td>-6.08</td><td>43.50</td><td>50.17</td><td>15.03</td><td>2.18</td><td>29.96</td><td>100</td><td>0</td><td>Peak</td></tr> <tr><td>4</td><td>834.10</td><td>36.66</td><td>-9.34</td><td>46.00</td><td>33.07</td><td>28.30</td><td>4.48</td><td>29.19</td><td>---</td><td>---</td><td>Peak</td></tr> <tr><td>5</td><td>895.00</td><td>42.52</td><td>-3.48</td><td>46.00</td><td>38.05</td><td>28.76</td><td>4.63</td><td>28.92</td><td>100</td><td>72</td><td>QP</td></tr> <tr><td>6</td><td>902.30</td><td>116.45</td><td>70.45</td><td>46.00</td><td>111.90</td><td>28.76</td><td>4.68</td><td>28.89</td><td>---</td><td>---</td><td>Peak</td></tr> <tr><td>7</td><td>909.70</td><td>42.40</td><td>-3.60</td><td>46.00</td><td>37.62</td><td>28.93</td><td>4.68</td><td>28.83</td><td>100</td><td>75</td><td>QP</td></tr> </tbody> </table>	Peak	Freq (MHz)	Level (dBuV/m)	Over Limit (dB)	Limit Line (dBuV/m)	ReadAntenna Level (dBuV)	Antenna Factor (dB/m)	Cable Loss (dB)	Preamp Loss (dB)	A/Pos (cm)	T/Pos (deg)	Remark	1	30.00	31.66	-8.34	40.00	36.05	24.60	1.19	30.18	---	---	Peak	2	68.34	33.64	-6.36	40.00	49.97	12.24	1.55	30.12	---	---	Peak	3	205.50	37.42	-6.08	43.50	50.17	15.03	2.18	29.96	100	0	Peak	4	834.10	36.66	-9.34	46.00	33.07	28.30	4.48	29.19	---	---	Peak	5	895.00	42.52	-3.48	46.00	38.05	28.76	4.63	28.92	100	72	QP	6	902.30	116.45	70.45	46.00	111.90	28.76	4.68	28.89	---	---	Peak	7	909.70	42.40	-3.60	46.00	37.62	28.93	4.68	28.83	100	75	QP
	Peak	Freq (MHz)	Level (dBuV/m)	Over Limit (dB)	Limit Line (dBuV/m)	ReadAntenna Level (dBuV)	Antenna Factor (dB/m)	Cable Loss (dB)	Preamp Loss (dB)	A/Pos (cm)	T/Pos (deg)	Remark																																																																																																																																																																																						
1	30.00	31.33	-8.67	40.00	35.72	24.60	1.19	30.18	---	---	Peak																																																																																																																																																																																							
2	45.66	31.52	-8.48	40.00	44.19	16.30	1.19	30.16	---	---	Peak																																																																																																																																																																																							
3	159.05	37.35	-6.15	43.50	45.67	16.62	2.07	30.01	100	0	Peak																																																																																																																																																																																							
4	699.00	34.95	-11.05	46.00	34.31	26.24	4.05	29.65	---	---	Peak																																																																																																																																																																																							
5	739.60	36.50	-9.42	46.00	34.32	27.68	4.11	29.53	---	---	Peak																																																																																																																																																																																							
6	902.30	115.90	69.90	46.00	111.35	28.76	4.68	28.89	---	---	Peak																																																																																																																																																																																							
7	951.00	34.72	-11.28	46.00	28.14	30.39	4.74	28.55	---	---	Peak																																																																																																																																																																																							
Peak	Freq (MHz)	Level (dBuV/m)	Over Limit (dB)	Limit Line (dBuV/m)	ReadAntenna Level (dBuV)	Antenna Factor (dB/m)	Cable Loss (dB)	Preamp Loss (dB)	A/Pos (cm)	T/Pos (deg)	Remark																																																																																																																																																																																							
1	30.00	31.66	-8.34	40.00	36.05	24.60	1.19	30.18	---	---	Peak																																																																																																																																																																																							
2	68.34	33.64	-6.36	40.00	49.97	12.24	1.55	30.12	---	---	Peak																																																																																																																																																																																							
3	205.50	37.42	-6.08	43.50	50.17	15.03	2.18	29.96	100	0	Peak																																																																																																																																																																																							
4	834.10	36.66	-9.34	46.00	33.07	28.30	4.48	29.19	---	---	Peak																																																																																																																																																																																							
5	895.00	42.52	-3.48	46.00	38.05	28.76	4.63	28.92	100	72	QP																																																																																																																																																																																							
6	902.30	116.45	70.45	46.00	111.90	28.76	4.68	28.89	---	---	Peak																																																																																																																																																																																							
7	909.70	42.40	-3.60	46.00	37.62	28.93	4.68	28.83	100	75	QP																																																																																																																																																																																							



902.3~927.75MHz

UHF (1GHz ~ 10GHz @ 3m)

ANT (Vertical)

UHF	902.3~927.5MHz UHF (1GHz ~ 10GHz @ 3m)																																																																																																																																																											
	UHF 902.3 MHz																																																																																																																																																											
	Horizontal	Vertical																																																																																																																																																										
Peak Avg.	<p>Site : 03CH07-HY Condition : PEAK_74 3m HF_ANT_00075962 HORIZONTAL Project : 921127 Mode : 12</p> <table border="1"> <thead> <tr> <th>Peak</th> <th>Freq</th> <th>Level</th> <th>Over</th> <th>Limit</th> <th>ReadAntenna</th> <th>Cable</th> <th>Preamp</th> <th>A/Pos</th> <th>T/Pos</th> <th>Remark</th> </tr> <tr> <th>1</th> <th>2786.90</th> <th>45.48</th> <th>-28.60</th> <th>74.00</th> <th>64.04</th> <th>32.60</th> <th>8.16</th> <th>59.40</th> <th>---</th> <th>Peak</th> </tr> </thead> <tbody> <tr> <td>2</td> <td>3689.28</td> <td>44.21</td> <td>-29.79</td> <td>74.00</td> <td>61.76</td> <td>32.90</td> <td>9.43</td> <td>59.88</td> <td>---</td> <td>Peak</td> </tr> <tr> <td>3</td> <td>4511.58</td> <td>42.00</td> <td>-32.00</td> <td>74.00</td> <td>57.63</td> <td>33.87</td> <td>10.47</td> <td>59.97</td> <td>---</td> <td>Peak</td> </tr> <tr> <td>4</td> <td>5413.88</td> <td>43.13</td> <td>-30.87</td> <td>74.00</td> <td>54.55</td> <td>34.63</td> <td>11.53</td> <td>57.58</td> <td>---</td> <td>Peak</td> </tr> <tr> <td>5</td> <td>8128.78</td> <td>45.16</td> <td>-28.84</td> <td>74.00</td> <td>53.17</td> <td>35.73</td> <td>14.24</td> <td>57.98</td> <td>---</td> <td>Peak</td> </tr> <tr> <td>6</td> <td>9023.88</td> <td>45.44</td> <td>-28.56</td> <td>74.00</td> <td>53.14</td> <td>36.83</td> <td>15.20</td> <td>58.93</td> <td>100</td> <td>Peak</td> </tr> </tbody> </table>	Peak	Freq	Level	Over	Limit	ReadAntenna	Cable	Preamp	A/Pos	T/Pos	Remark	1	2786.90	45.48	-28.60	74.00	64.04	32.60	8.16	59.40	---	Peak	2	3689.28	44.21	-29.79	74.00	61.76	32.90	9.43	59.88	---	Peak	3	4511.58	42.00	-32.00	74.00	57.63	33.87	10.47	59.97	---	Peak	4	5413.88	43.13	-30.87	74.00	54.55	34.63	11.53	57.58	---	Peak	5	8128.78	45.16	-28.84	74.00	53.17	35.73	14.24	57.98	---	Peak	6	9023.88	45.44	-28.56	74.00	53.14	36.83	15.20	58.93	100	Peak	<p>Site : 03CH07-HY Condition : PEAK_74 3m HF_ANT_00075962 VERTICAL Project : 921127 Mode : 12</p> <table border="1"> <thead> <tr> <th>Peak</th> <th>Freq</th> <th>Level</th> <th>Over</th> <th>Limit</th> <th>ReadAntenna</th> <th>Cable</th> <th>Preamp</th> <th>A/Pos</th> <th>T/Pos</th> <th>Remark</th> </tr> <tr> <th>1</th> <th>2786.90</th> <th>44.57</th> <th>-29.43</th> <th>74.00</th> <th>63.21</th> <th>32.60</th> <th>8.16</th> <th>59.40</th> <th>---</th> <th>Peak</th> </tr> </thead> <tbody> <tr> <td>2</td> <td>3689.28</td> <td>45.15</td> <th>-28.85</th> <th>74.00</th> <th>62.70</th> <th>32.90</th> <th>9.43</th> <th>59.88</th> <th>---</th> <th>Peak</th> </tr> <tr> <td>3</td> <td>4511.58</td> <td>42.78</td> <th>-32.22</th> <th>74.00</th> <th>57.41</th> <th>33.87</th> <th>10.47</th> <th>59.97</th> <th>---</th> <th>Peak</th> </tr> <tr> <td>4</td> <td>5413.88</td> <td>44.73</td> <th>-29.27</th> <th>74.00</th> <th>56.15</th> <th>34.63</th> <th>11.53</th> <th>57.58</th> <th>---</th> <th>Peak</th> </tr> <tr> <td>5</td> <td>8128.78</td> <td>45.17</td> <th>-28.83</th> <th>74.00</th> <th>53.18</th> <th>35.73</th> <th>14.24</th> <th>57.98</th> <th>---</th> <th>Peak</th> </tr> <tr> <td>6</td> <td>9023.88</td> <td>45.76</td> <th>-28.24</th> <th>74.00</th> <th>53.46</th> <th>36.83</th> <th>15.20</th> <th>58.93</th> <th>100</th> <th>Peak</th> </tr> </tbody> </table>	Peak	Freq	Level	Over	Limit	ReadAntenna	Cable	Preamp	A/Pos	T/Pos	Remark	1	2786.90	44.57	-29.43	74.00	63.21	32.60	8.16	59.40	---	Peak	2	3689.28	45.15	-28.85	74.00	62.70	32.90	9.43	59.88	---	Peak	3	4511.58	42.78	-32.22	74.00	57.41	33.87	10.47	59.97	---	Peak	4	5413.88	44.73	-29.27	74.00	56.15	34.63	11.53	57.58	---	Peak	5	8128.78	45.17	-28.83	74.00	53.18	35.73	14.24	57.98	---	Peak	6	9023.88	45.76	-28.24	74.00	53.46	36.83	15.20	58.93	100	Peak
	Peak	Freq	Level	Over	Limit	ReadAntenna	Cable	Preamp	A/Pos	T/Pos	Remark																																																																																																																																																	
1	2786.90	45.48	-28.60	74.00	64.04	32.60	8.16	59.40	---	Peak																																																																																																																																																		
2	3689.28	44.21	-29.79	74.00	61.76	32.90	9.43	59.88	---	Peak																																																																																																																																																		
3	4511.58	42.00	-32.00	74.00	57.63	33.87	10.47	59.97	---	Peak																																																																																																																																																		
4	5413.88	43.13	-30.87	74.00	54.55	34.63	11.53	57.58	---	Peak																																																																																																																																																		
5	8128.78	45.16	-28.84	74.00	53.17	35.73	14.24	57.98	---	Peak																																																																																																																																																		
6	9023.88	45.44	-28.56	74.00	53.14	36.83	15.20	58.93	100	Peak																																																																																																																																																		
Peak	Freq	Level	Over	Limit	ReadAntenna	Cable	Preamp	A/Pos	T/Pos	Remark																																																																																																																																																		
1	2786.90	44.57	-29.43	74.00	63.21	32.60	8.16	59.40	---	Peak																																																																																																																																																		
2	3689.28	45.15	-28.85	74.00	62.70	32.90	9.43	59.88	---	Peak																																																																																																																																																		
3	4511.58	42.78	-32.22	74.00	57.41	33.87	10.47	59.97	---	Peak																																																																																																																																																		
4	5413.88	44.73	-29.27	74.00	56.15	34.63	11.53	57.58	---	Peak																																																																																																																																																		
5	8128.78	45.17	-28.83	74.00	53.18	35.73	14.24	57.98	---	Peak																																																																																																																																																		
6	9023.88	45.76	-28.24	74.00	53.46	36.83	15.20	58.93	100	Peak																																																																																																																																																		



902.3~927.75MHz

UHF (30MHz ~ 1GHz @ 3m)

ANT (Vertical)

UHF	902.3~927.75MHz UHF (30MHz ~ 1GHz @ 3m)																																																																																																																																																																																																																					
	UHF 914.5 MHz																																																																																																																																																																																																																					
	Horizontal	Vertical																																																																																																																																																																																																																				
QP / Peak	<p>Date: 2019-04-11</p> <p>Site : 03CH07-HY Condition : QP 3m LF-ANT-35419(6) HORIZONTAL Project : 921127 Mode : 13</p> <table border="1"> <thead> <tr> <th>Over</th> <th>Limit</th> <th>ReadAntenna</th> <th>Cable Preamp</th> <th>A/Pos</th> <th>T/Pos</th> <th>Remark</th> </tr> <tr> <th>Level</th> <th>Line</th> <th>Level Factor</th> <th>Loss Factor</th> <th>cm</th> <th>deg</th> <th></th> </tr> <tr> <th>MHz</th> <th>dBuV/m</th> <th>dB</th> <th>dBuV/m</th> <th>dBuV</th> <th>dB/m</th> <th>dB</th> <th>dB</th> </tr> </thead> <tbody> <tr> <td>1</td> <td>38.00</td> <td>31.87</td> <td>-8.93</td> <td>40.00</td> <td>35.46</td> <td>24.60</td> <td>1.19</td> <td>30.18</td> <td>---</td> <td>---</td> <td>Peak</td> </tr> <tr> <td>2</td> <td>204.15</td> <td>36.56</td> <td>-6.94</td> <td>43.50</td> <td>49.33</td> <td>15.01</td> <td>2.18</td> <td>29.96</td> <td>100</td> <td>0</td> <td>Peak</td> </tr> <tr> <td>3</td> <td>245.46</td> <td>39.95</td> <td>-7.05</td> <td>46.00</td> <td>48.68</td> <td>17.00</td> <td>2.42</td> <td>29.95</td> <td>---</td> <td>---</td> <td>Peak</td> </tr> <tr> <td>4</td> <td>668.90</td> <td>35.78</td> <td>-10.22</td> <td>46.00</td> <td>35.23</td> <td>26.21</td> <td>4.05</td> <td>29.71</td> <td>---</td> <td>---</td> <td>Peak</td> </tr> <tr> <td>5</td> <td>809.60</td> <td>34.21</td> <td>-11.79</td> <td>46.00</td> <td>31.31</td> <td>27.87</td> <td>4.33</td> <td>29.30</td> <td>---</td> <td>---</td> <td>Peak</td> </tr> <tr> <td>6</td> <td>914.50</td> <td>115.81</td> <td>69.83</td> <td>46.00</td> <td>110.91</td> <td>29.84</td> <td>4.68</td> <td>28.80</td> <td>---</td> <td>---</td> <td>Peak</td> </tr> <tr> <td>7</td> <td>949.60</td> <td>34.02</td> <td>-11.98</td> <td>46.00</td> <td>27.51</td> <td>30.33</td> <td>4.74</td> <td>28.56</td> <td>---</td> <td>---</td> <td>Peak</td> </tr> </tbody> </table>	Over	Limit	ReadAntenna	Cable Preamp	A/Pos	T/Pos	Remark	Level	Line	Level Factor	Loss Factor	cm	deg		MHz	dBuV/m	dB	dBuV/m	dBuV	dB/m	dB	dB	1	38.00	31.87	-8.93	40.00	35.46	24.60	1.19	30.18	---	---	Peak	2	204.15	36.56	-6.94	43.50	49.33	15.01	2.18	29.96	100	0	Peak	3	245.46	39.95	-7.05	46.00	48.68	17.00	2.42	29.95	---	---	Peak	4	668.90	35.78	-10.22	46.00	35.23	26.21	4.05	29.71	---	---	Peak	5	809.60	34.21	-11.79	46.00	31.31	27.87	4.33	29.30	---	---	Peak	6	914.50	115.81	69.83	46.00	110.91	29.84	4.68	28.80	---	---	Peak	7	949.60	34.02	-11.98	46.00	27.51	30.33	4.74	28.56	---	---	Peak	<p>Date: 2019-04-11</p> <p>Site : 03CH07-HY Condition : QP 3m LF-ANT-35419(6) VERTICAL Project : 921127 Mode : 13</p> <table border="1"> <thead> <tr> <th>Over</th> <th>Limit</th> <th>ReadAntenna</th> <th>Cable Preamp</th> <th>A/Pos</th> <th>T/Pos</th> <th>Remark</th> </tr> <tr> <th>Level</th> <th>Line</th> <th>Level Factor</th> <th>Loss Factor</th> <th>cm</th> <th>deg</th> <th></th> </tr> <tr> <th>MHz</th> <th>dBuV/m</th> <th>dB</th> <th>dBuV/m</th> <th>dBuV</th> <th>dB/m</th> <th>dB</th> <th>dB</th> </tr> </thead> <tbody> <tr> <td>1</td> <td>30.27</td> <td>31.74</td> <td>-8.26</td> <td>40.00</td> <td>36.13</td> <td>24.60</td> <td>1.19</td> <td>30.18</td> <td>---</td> <td>---</td> <td>Peak</td> </tr> <tr> <td>2</td> <td>68.61</td> <td>33.82</td> <td>-6.18</td> <td>40.00</td> <td>50.15</td> <td>12.24</td> <td>1.55</td> <td>30.12</td> <td>---</td> <td>---</td> <td>Peak</td> </tr> <tr> <td>3</td> <td>206.58</td> <td>33.52</td> <td>-9.00</td> <td>43.50</td> <td>46.25</td> <td>15.05</td> <td>2.18</td> <td>29.96</td> <td>---</td> <td>---</td> <td>Peak</td> </tr> <tr> <td>4</td> <td>845.30</td> <td>38.78</td> <td>-7.22</td> <td>46.00</td> <td>34.78</td> <td>28.66</td> <td>4.48</td> <td>29.14</td> <td>---</td> <td>---</td> <td>Peak</td> </tr> <tr> <td>5</td> <td>906.90</td> <td>42.81</td> <td>-3.19</td> <td>46.00</td> <td>38.11</td> <td>28.07</td> <td>4.68</td> <td>28.85</td> <td>100</td> <td>326</td> <td>QP</td> </tr> <tr> <td>6</td> <td>914.50</td> <td>117.02</td> <td>71.02</td> <td>46.00</td> <td>112.10</td> <td>29.84</td> <td>4.68</td> <td>28.80</td> <td>---</td> <td>---</td> <td>Peak</td> </tr> <tr> <td>7</td> <td>921.60</td> <td>42.67</td> <td>-3.33</td> <td>46.00</td> <td>37.54</td> <td>29.20</td> <td>4.68</td> <td>28.75</td> <td>100</td> <td>338</td> <td>QP</td> </tr> </tbody> </table>	Over	Limit	ReadAntenna	Cable Preamp	A/Pos	T/Pos	Remark	Level	Line	Level Factor	Loss Factor	cm	deg		MHz	dBuV/m	dB	dBuV/m	dBuV	dB/m	dB	dB	1	30.27	31.74	-8.26	40.00	36.13	24.60	1.19	30.18	---	---	Peak	2	68.61	33.82	-6.18	40.00	50.15	12.24	1.55	30.12	---	---	Peak	3	206.58	33.52	-9.00	43.50	46.25	15.05	2.18	29.96	---	---	Peak	4	845.30	38.78	-7.22	46.00	34.78	28.66	4.48	29.14	---	---	Peak	5	906.90	42.81	-3.19	46.00	38.11	28.07	4.68	28.85	100	326	QP	6	914.50	117.02	71.02	46.00	112.10	29.84	4.68	28.80	---	---	Peak	7	921.60	42.67	-3.33	46.00	37.54	29.20	4.68	28.75	100	338	QP
	Over	Limit	ReadAntenna	Cable Preamp	A/Pos	T/Pos	Remark																																																																																																																																																																																																															
Level	Line	Level Factor	Loss Factor	cm	deg																																																																																																																																																																																																																	
MHz	dBuV/m	dB	dBuV/m	dBuV	dB/m	dB	dB																																																																																																																																																																																																															
1	38.00	31.87	-8.93	40.00	35.46	24.60	1.19	30.18	---	---	Peak																																																																																																																																																																																																											
2	204.15	36.56	-6.94	43.50	49.33	15.01	2.18	29.96	100	0	Peak																																																																																																																																																																																																											
3	245.46	39.95	-7.05	46.00	48.68	17.00	2.42	29.95	---	---	Peak																																																																																																																																																																																																											
4	668.90	35.78	-10.22	46.00	35.23	26.21	4.05	29.71	---	---	Peak																																																																																																																																																																																																											
5	809.60	34.21	-11.79	46.00	31.31	27.87	4.33	29.30	---	---	Peak																																																																																																																																																																																																											
6	914.50	115.81	69.83	46.00	110.91	29.84	4.68	28.80	---	---	Peak																																																																																																																																																																																																											
7	949.60	34.02	-11.98	46.00	27.51	30.33	4.74	28.56	---	---	Peak																																																																																																																																																																																																											
Over	Limit	ReadAntenna	Cable Preamp	A/Pos	T/Pos	Remark																																																																																																																																																																																																																
Level	Line	Level Factor	Loss Factor	cm	deg																																																																																																																																																																																																																	
MHz	dBuV/m	dB	dBuV/m	dBuV	dB/m	dB	dB																																																																																																																																																																																																															
1	30.27	31.74	-8.26	40.00	36.13	24.60	1.19	30.18	---	---	Peak																																																																																																																																																																																																											
2	68.61	33.82	-6.18	40.00	50.15	12.24	1.55	30.12	---	---	Peak																																																																																																																																																																																																											
3	206.58	33.52	-9.00	43.50	46.25	15.05	2.18	29.96	---	---	Peak																																																																																																																																																																																																											
4	845.30	38.78	-7.22	46.00	34.78	28.66	4.48	29.14	---	---	Peak																																																																																																																																																																																																											
5	906.90	42.81	-3.19	46.00	38.11	28.07	4.68	28.85	100	326	QP																																																																																																																																																																																																											
6	914.50	117.02	71.02	46.00	112.10	29.84	4.68	28.80	---	---	Peak																																																																																																																																																																																																											
7	921.60	42.67	-3.33	46.00	37.54	29.20	4.68	28.75	100	338	QP																																																																																																																																																																																																											



902.3~927.75MHz

UHF (1GHz ~ 10GHz @ 3m)

ANT (Vertical)

UHF	902.3~927.5MHz UHF (1GHz ~ 10GHz @ 3m)																																																																																																																																																																																	
	UHF 914.5 MHz																																																																																																																																																																																	
	Horizontal	Vertical																																																																																																																																																																																
Peak Avg.	<p>Site : 03CH07-HY Condition : PEAK_74 3m HF_ANT_00075962 HORIZONTAL Project : 921127 Mode : 13</p> <table border="1"> <thead> <tr> <th>Peak</th> <th>Freq</th> <th>Level</th> <th>Over</th> <th>Limit</th> <th>ReadAntenna</th> <th>Cable</th> <th>Preamp</th> <th>A/Pos</th> <th>T/Pos</th> <th>Remark</th> </tr> <tr> <th></th> <th>MHz</th> <th>dBuV/m</th> <th>dB</th> <th>dBuV/m</th> <th>dBuV</th> <th>dB/m</th> <th>dB</th> <th>dB</th> <th>cm</th> <th>deg</th> </tr> </thead> <tbody> <tr> <td>1</td> <td>2743.50</td> <td>53.05</td> <td>-20.95</td> <td>74.00</td> <td>71.73</td> <td>32.50</td> <td>8.22</td> <td>59.40</td> <td>100</td> <td>0 Peak</td> </tr> <tr> <td>2</td> <td>3658.00</td> <td>50.37</td> <td>-23.63</td> <td>74.00</td> <td>67.91</td> <td>32.90</td> <td>9.48</td> <td>59.92</td> <td>---</td> <td>Peak</td> </tr> <tr> <td>3</td> <td>4572.50</td> <td>42.39</td> <td>-31.61</td> <td>74.00</td> <td>57.74</td> <td>34.00</td> <td>10.51</td> <td>59.86</td> <td>---</td> <td>Peak</td> </tr> <tr> <td>4</td> <td>7316.00</td> <td>40.51</td> <td>-33.49</td> <td>74.00</td> <td>49.54</td> <td>35.63</td> <td>13.50</td> <td>58.16</td> <td>---</td> <td>Peak</td> </tr> <tr> <td>5</td> <td>8238.50</td> <td>36.72</td> <td>-37.28</td> <td>74.00</td> <td>44.53</td> <td>35.80</td> <td>14.35</td> <td>57.96</td> <td>---</td> <td>Peak</td> </tr> <tr> <td>6</td> <td>9145.00</td> <td>35.13</td> <td>-38.87</td> <td>74.00</td> <td>42.86</td> <td>36.10</td> <td>15.35</td> <td>59.18</td> <td>---</td> <td>Peak</td> </tr> </tbody> </table>	Peak	Freq	Level	Over	Limit	ReadAntenna	Cable	Preamp	A/Pos	T/Pos	Remark		MHz	dBuV/m	dB	dBuV/m	dBuV	dB/m	dB	dB	cm	deg	1	2743.50	53.05	-20.95	74.00	71.73	32.50	8.22	59.40	100	0 Peak	2	3658.00	50.37	-23.63	74.00	67.91	32.90	9.48	59.92	---	Peak	3	4572.50	42.39	-31.61	74.00	57.74	34.00	10.51	59.86	---	Peak	4	7316.00	40.51	-33.49	74.00	49.54	35.63	13.50	58.16	---	Peak	5	8238.50	36.72	-37.28	74.00	44.53	35.80	14.35	57.96	---	Peak	6	9145.00	35.13	-38.87	74.00	42.86	36.10	15.35	59.18	---	Peak	<p>Site : 03CH07-HY Condition : PEAK_74 3m HF_ANT_00075962 VERTICAL Project : 921127 Mode : 13</p> <table border="1"> <thead> <tr> <th>Peak</th> <th>Freq</th> <th>Level</th> <th>Over</th> <th>Limit</th> <th>ReadAntenna</th> <th>Cable</th> <th>Preamp</th> <th>A/Pos</th> <th>T/Pos</th> <th>Remark</th> </tr> <tr> <th></th> <th>MHz</th> <th>dBuV/m</th> <th>dB</th> <th>dBuV/m</th> <th>dBuV</th> <th>dB/m</th> <th>dB</th> <th>dB</th> <th>cm</th> <th>deg</th> </tr> </thead> <tbody> <tr> <td>1</td> <td>2743.50</td> <td>51.95</td> <td>-22.05</td> <td>74.00</td> <td>70.63</td> <td>32.50</td> <td>8.22</td> <td>59.40</td> <td>100</td> <td>0 Peak</td> </tr> <tr> <td>2</td> <td>3658.00</td> <td>49.47</td> <td>-24.53</td> <td>74.00</td> <td>67.01</td> <td>32.90</td> <td>9.48</td> <td>59.92</td> <td>---</td> <td>Peak</td> </tr> <tr> <td>3</td> <td>4572.50</td> <td>43.14</td> <td>-30.86</td> <td>74.00</td> <td>58.09</td> <td>34.00</td> <td>10.51</td> <td>59.86</td> <td>---</td> <td>Peak</td> </tr> <tr> <td>4</td> <td>7316.00</td> <td>39.80</td> <td>-34.20</td> <td>74.00</td> <td>48.83</td> <td>35.63</td> <td>13.50</td> <td>58.16</td> <td>---</td> <td>Peak</td> </tr> <tr> <td>5</td> <td>8238.50</td> <td>36.23</td> <td>-37.77</td> <td>74.00</td> <td>44.04</td> <td>35.80</td> <td>14.35</td> <td>57.96</td> <td>---</td> <td>Peak</td> </tr> <tr> <td>6</td> <td>9145.00</td> <td>34.56</td> <td>-39.44</td> <td>74.00</td> <td>42.29</td> <td>36.10</td> <td>15.35</td> <td>59.18</td> <td>---</td> <td>Peak</td> </tr> </tbody> </table>	Peak	Freq	Level	Over	Limit	ReadAntenna	Cable	Preamp	A/Pos	T/Pos	Remark		MHz	dBuV/m	dB	dBuV/m	dBuV	dB/m	dB	dB	cm	deg	1	2743.50	51.95	-22.05	74.00	70.63	32.50	8.22	59.40	100	0 Peak	2	3658.00	49.47	-24.53	74.00	67.01	32.90	9.48	59.92	---	Peak	3	4572.50	43.14	-30.86	74.00	58.09	34.00	10.51	59.86	---	Peak	4	7316.00	39.80	-34.20	74.00	48.83	35.63	13.50	58.16	---	Peak	5	8238.50	36.23	-37.77	74.00	44.04	35.80	14.35	57.96	---	Peak	6	9145.00	34.56	-39.44	74.00	42.29	36.10	15.35	59.18	---	Peak
	Peak	Freq	Level	Over	Limit	ReadAntenna	Cable	Preamp	A/Pos	T/Pos	Remark																																																																																																																																																																							
	MHz	dBuV/m	dB	dBuV/m	dBuV	dB/m	dB	dB	cm	deg																																																																																																																																																																								
1	2743.50	53.05	-20.95	74.00	71.73	32.50	8.22	59.40	100	0 Peak																																																																																																																																																																								
2	3658.00	50.37	-23.63	74.00	67.91	32.90	9.48	59.92	---	Peak																																																																																																																																																																								
3	4572.50	42.39	-31.61	74.00	57.74	34.00	10.51	59.86	---	Peak																																																																																																																																																																								
4	7316.00	40.51	-33.49	74.00	49.54	35.63	13.50	58.16	---	Peak																																																																																																																																																																								
5	8238.50	36.72	-37.28	74.00	44.53	35.80	14.35	57.96	---	Peak																																																																																																																																																																								
6	9145.00	35.13	-38.87	74.00	42.86	36.10	15.35	59.18	---	Peak																																																																																																																																																																								
Peak	Freq	Level	Over	Limit	ReadAntenna	Cable	Preamp	A/Pos	T/Pos	Remark																																																																																																																																																																								
	MHz	dBuV/m	dB	dBuV/m	dBuV	dB/m	dB	dB	cm	deg																																																																																																																																																																								
1	2743.50	51.95	-22.05	74.00	70.63	32.50	8.22	59.40	100	0 Peak																																																																																																																																																																								
2	3658.00	49.47	-24.53	74.00	67.01	32.90	9.48	59.92	---	Peak																																																																																																																																																																								
3	4572.50	43.14	-30.86	74.00	58.09	34.00	10.51	59.86	---	Peak																																																																																																																																																																								
4	7316.00	39.80	-34.20	74.00	48.83	35.63	13.50	58.16	---	Peak																																																																																																																																																																								
5	8238.50	36.23	-37.77	74.00	44.04	35.80	14.35	57.96	---	Peak																																																																																																																																																																								
6	9145.00	34.56	-39.44	74.00	42.29	36.10	15.35	59.18	---	Peak																																																																																																																																																																								



902.3~927.75MHz

UHF (30MHz ~ 1GHz @ 3m)

ANT (Vertical)

UHF	902.3~927.75MHz UHF (30MHz ~ 1GHz @ 3m)																																																																																																																																																																																																	
	UHF 927.75 MHz																																																																																																																																																																																																	
	Horizontal	Vertical																																																																																																																																																																																																
QP / Peak	<p>Date: 2019-04-11</p> <p>Site : 03CH07-HY Condition : QP 3m LF-ANT-35419(6) HORIZONTAL Project : 921127 Mode : 14</p> <table border="1"> <thead> <tr> <th>Peak</th> <th>Freq (MHz)</th> <th>Level (dBuV/m)</th> <th>Over Limit (dB)</th> <th>Limit (dBuV/m)</th> <th>ReadAntenna Level (dBuV)</th> <th>Antenna Factor (dB/m)</th> <th>Cable Loss (dB)</th> <th>Preamp Loss (dB)</th> <th>A/Pos (cm)</th> <th>T/Pos (deg)</th> <th>Remark</th> </tr> </thead> <tbody> <tr><td>1</td><td>159.33</td><td>36.61</td><td>-6.89</td><td>43.50</td><td>47.93</td><td>16.62</td><td>2.97</td><td>30.81</td><td>---</td><td>---</td><td>Peak</td></tr> <tr><td>2</td><td>204.96</td><td>36.94</td><td>-6.56</td><td>43.50</td><td>49.71</td><td>15.01</td><td>2.18</td><td>29.96</td><td>100</td><td>0</td><td>Peak</td></tr> <tr><td>3</td><td>245.65</td><td>38.24</td><td>-7.76</td><td>46.00</td><td>48.09</td><td>17.68</td><td>2.42</td><td>29.95</td><td>---</td><td>---</td><td>Peak</td></tr> <tr><td>4</td><td>685.79</td><td>35.03</td><td>-18.97</td><td>46.00</td><td>34.41</td><td>26.25</td><td>4.05</td><td>29.68</td><td>---</td><td>---</td><td>Peak</td></tr> <tr><td>5</td><td>762.80</td><td>34.89</td><td>-11.91</td><td>46.00</td><td>31.52</td><td>27.85</td><td>4.18</td><td>29.46</td><td>---</td><td>---</td><td>Peak</td></tr> <tr><td>6</td><td>927.75</td><td>115.77</td><td>68.77</td><td>46.00</td><td>109.32</td><td>29.43</td><td>4.68</td><td>28.71</td><td>---</td><td>---</td><td>Peak</td></tr> <tr><td>7</td><td>954.58</td><td>34.48</td><td>-11.52</td><td>46.00</td><td>27.68</td><td>30.59</td><td>4.74</td><td>28.53</td><td>---</td><td>---</td><td>Peak</td></tr> </tbody> </table>	Peak	Freq (MHz)	Level (dBuV/m)	Over Limit (dB)	Limit (dBuV/m)	ReadAntenna Level (dBuV)	Antenna Factor (dB/m)	Cable Loss (dB)	Preamp Loss (dB)	A/Pos (cm)	T/Pos (deg)	Remark	1	159.33	36.61	-6.89	43.50	47.93	16.62	2.97	30.81	---	---	Peak	2	204.96	36.94	-6.56	43.50	49.71	15.01	2.18	29.96	100	0	Peak	3	245.65	38.24	-7.76	46.00	48.09	17.68	2.42	29.95	---	---	Peak	4	685.79	35.03	-18.97	46.00	34.41	26.25	4.05	29.68	---	---	Peak	5	762.80	34.89	-11.91	46.00	31.52	27.85	4.18	29.46	---	---	Peak	6	927.75	115.77	68.77	46.00	109.32	29.43	4.68	28.71	---	---	Peak	7	954.58	34.48	-11.52	46.00	27.68	30.59	4.74	28.53	---	---	Peak	<p>Date: 2019-04-11</p> <p>Site : 03CH07-HY Condition : QP 3m LF-ANT-35419(6) VERTICAL Project : 921127 Mode : 14</p> <table border="1"> <thead> <tr> <th>Peak</th> <th>Freq (MHz)</th> <th>Level (dBuV/m)</th> <th>Over Limit (dB)</th> <th>Limit (dBuV/m)</th> <th>ReadAntenna Level (dBuV)</th> <th>Antenna Factor (dB/m)</th> <th>Cable Loss (dB)</th> <th>Preamp Loss (dB)</th> <th>A/Pos (cm)</th> <th>T/Pos (deg)</th> <th>Remark</th> </tr> </thead> <tbody> <tr><td>1</td><td>30.00</td><td>32.84</td><td>-7.96</td><td>40.00</td><td>36.43</td><td>24.60</td><td>1.19</td><td>30.18</td><td>---</td><td>---</td><td>Peak</td></tr> <tr><td>2</td><td>70.58</td><td>33.01</td><td>-6.99</td><td>40.00</td><td>49.16</td><td>12.42</td><td>1.55</td><td>30.12</td><td>---</td><td>---</td><td>Peak</td></tr> <tr><td>3</td><td>309.28</td><td>33.23</td><td>-16.27</td><td>43.50</td><td>45.90</td><td>15.11</td><td>2.18</td><td>29.96</td><td>---</td><td>---</td><td>Peak</td></tr> <tr><td>4</td><td>859.30</td><td>38.82</td><td>-7.18</td><td>46.00</td><td>34.41</td><td>29.01</td><td>4.48</td><td>29.08</td><td>---</td><td>---</td><td>Peak</td></tr> <tr><td>5</td><td>920.29</td><td>42.46</td><td>-3.54</td><td>46.00</td><td>37.38</td><td>29.17</td><td>4.68</td><td>28.77</td><td>100</td><td>355</td><td>QP</td></tr> <tr><td>6</td><td>927.75</td><td>117.36</td><td>71.36</td><td>46.00</td><td>111.96</td><td>29.43</td><td>4.68</td><td>28.71</td><td>---</td><td>---</td><td>Peak</td></tr> <tr><td>7</td><td>934.98</td><td>42.56</td><td>-3.44</td><td>46.00</td><td>36.88</td><td>29.66</td><td>4.68</td><td>28.66</td><td>100</td><td>332</td><td>QP</td></tr> </tbody> </table>	Peak	Freq (MHz)	Level (dBuV/m)	Over Limit (dB)	Limit (dBuV/m)	ReadAntenna Level (dBuV)	Antenna Factor (dB/m)	Cable Loss (dB)	Preamp Loss (dB)	A/Pos (cm)	T/Pos (deg)	Remark	1	30.00	32.84	-7.96	40.00	36.43	24.60	1.19	30.18	---	---	Peak	2	70.58	33.01	-6.99	40.00	49.16	12.42	1.55	30.12	---	---	Peak	3	309.28	33.23	-16.27	43.50	45.90	15.11	2.18	29.96	---	---	Peak	4	859.30	38.82	-7.18	46.00	34.41	29.01	4.48	29.08	---	---	Peak	5	920.29	42.46	-3.54	46.00	37.38	29.17	4.68	28.77	100	355	QP	6	927.75	117.36	71.36	46.00	111.96	29.43	4.68	28.71	---	---	Peak	7	934.98	42.56	-3.44	46.00	36.88	29.66	4.68	28.66	100	332	QP
	Peak	Freq (MHz)	Level (dBuV/m)	Over Limit (dB)	Limit (dBuV/m)	ReadAntenna Level (dBuV)	Antenna Factor (dB/m)	Cable Loss (dB)	Preamp Loss (dB)	A/Pos (cm)	T/Pos (deg)	Remark																																																																																																																																																																																						
1	159.33	36.61	-6.89	43.50	47.93	16.62	2.97	30.81	---	---	Peak																																																																																																																																																																																							
2	204.96	36.94	-6.56	43.50	49.71	15.01	2.18	29.96	100	0	Peak																																																																																																																																																																																							
3	245.65	38.24	-7.76	46.00	48.09	17.68	2.42	29.95	---	---	Peak																																																																																																																																																																																							
4	685.79	35.03	-18.97	46.00	34.41	26.25	4.05	29.68	---	---	Peak																																																																																																																																																																																							
5	762.80	34.89	-11.91	46.00	31.52	27.85	4.18	29.46	---	---	Peak																																																																																																																																																																																							
6	927.75	115.77	68.77	46.00	109.32	29.43	4.68	28.71	---	---	Peak																																																																																																																																																																																							
7	954.58	34.48	-11.52	46.00	27.68	30.59	4.74	28.53	---	---	Peak																																																																																																																																																																																							
Peak	Freq (MHz)	Level (dBuV/m)	Over Limit (dB)	Limit (dBuV/m)	ReadAntenna Level (dBuV)	Antenna Factor (dB/m)	Cable Loss (dB)	Preamp Loss (dB)	A/Pos (cm)	T/Pos (deg)	Remark																																																																																																																																																																																							
1	30.00	32.84	-7.96	40.00	36.43	24.60	1.19	30.18	---	---	Peak																																																																																																																																																																																							
2	70.58	33.01	-6.99	40.00	49.16	12.42	1.55	30.12	---	---	Peak																																																																																																																																																																																							
3	309.28	33.23	-16.27	43.50	45.90	15.11	2.18	29.96	---	---	Peak																																																																																																																																																																																							
4	859.30	38.82	-7.18	46.00	34.41	29.01	4.48	29.08	---	---	Peak																																																																																																																																																																																							
5	920.29	42.46	-3.54	46.00	37.38	29.17	4.68	28.77	100	355	QP																																																																																																																																																																																							
6	927.75	117.36	71.36	46.00	111.96	29.43	4.68	28.71	---	---	Peak																																																																																																																																																																																							
7	934.98	42.56	-3.44	46.00	36.88	29.66	4.68	28.66	100	332	QP																																																																																																																																																																																							



902.3~927.75MHz

UHF (1GHz ~ 10GHz @ 3m)

ANT (Vertical)

UHF	902.3~927.5MHz UHF (1GHz ~ 10GHz @ 3m)																																																																																																																																													
	UHF 927.75 MHz																																																																																																																																													
	Horizontal	Vertical																																																																																																																																												
Peak Avg.	<p>Site : 03CH07-HY Condition : PEAK_74 3m HF_ANT_00075962 HORIZONTAL Project : 921127 Mode : 14</p> <table border="1"> <thead> <tr> <th>Peak</th> <th>Level</th> <th>Over</th> <th>Limit</th> <th>ReadAntenna</th> <th>Cable</th> <th>Preamp</th> <th>A/Pos</th> <th>T/Pos</th> <th>Remark</th> </tr> <tr> <th>1</th> <th>2783.25</th> <th>53.42</th> <th>-20.58</th> <th>74.00</th> <th>72.11</th> <th>32.43</th> <th>8.28</th> <th>59.40</th> <th>100 0 Peak</th> </tr> </thead> <tbody> <tr> <td>2</td> <td>3711.00</td> <td>49.55</td> <td>-24.45</td> <td>74.00</td> <td>66.94</td> <td>33.00</td> <td>9.58</td> <td>59.97</td> <td>--- --- Peak</td> </tr> <tr> <td>3</td> <td>4638.75</td> <td>43.19</td> <td>-31.81</td> <td>74.00</td> <td>57.22</td> <td>34.07</td> <td>10.62</td> <td>59.72</td> <td>--- --- Peak</td> </tr> <tr> <td>4</td> <td>7422.00</td> <td>39.15</td> <td>-34.85</td> <td>74.00</td> <td>48.33</td> <td>35.50</td> <td>13.62</td> <td>58.30</td> <td>--- --- Peak</td> </tr> <tr> <td>5</td> <td>8349.75</td> <td>36.14</td> <td>-37.86</td> <td>74.00</td> <td>43.98</td> <td>35.60</td> <td>14.49</td> <td>57.93</td> <td>--- --- Peak</td> </tr> <tr> <td>6</td> <td>9277.50</td> <td>34.17</td> <td>-39.83</td> <td>74.00</td> <td>42.04</td> <td>36.07</td> <td>15.51</td> <td>59.45</td> <td>--- --- Peak</td> </tr> </tbody> </table>	Peak	Level	Over	Limit	ReadAntenna	Cable	Preamp	A/Pos	T/Pos	Remark	1	2783.25	53.42	-20.58	74.00	72.11	32.43	8.28	59.40	100 0 Peak	2	3711.00	49.55	-24.45	74.00	66.94	33.00	9.58	59.97	--- --- Peak	3	4638.75	43.19	-31.81	74.00	57.22	34.07	10.62	59.72	--- --- Peak	4	7422.00	39.15	-34.85	74.00	48.33	35.50	13.62	58.30	--- --- Peak	5	8349.75	36.14	-37.86	74.00	43.98	35.60	14.49	57.93	--- --- Peak	6	9277.50	34.17	-39.83	74.00	42.04	36.07	15.51	59.45	--- --- Peak	<p>Site : 03CH07-HY Condition : PEAK_74 3m HF_ANT_00075962 VERTICAL Project : 921127 Mode : 14</p> <table border="1"> <thead> <tr> <th>Peak</th> <th>Level</th> <th>Over</th> <th>Limit</th> <th>ReadAntenna</th> <th>Cable</th> <th>Preamp</th> <th>A/Pos</th> <th>T/Pos</th> <th>Remark</th> </tr> <tr> <th>1</th> <th>2783.25</th> <th>54.45</th> <th>-19.55</th> <th>74.00</th> <th>73.14</th> <th>32.43</th> <th>8.28</th> <th>59.40</th> <th>100 0 Peak</th> </tr> </thead> <tbody> <tr> <td>2</td> <td>3711.00</td> <td>47.18</td> <td>-26.82</td> <td>74.00</td> <td>64.57</td> <td>33.00</td> <td>9.58</td> <td>59.97</td> <td>--- --- Peak</td> </tr> <tr> <td>3</td> <td>4638.75</td> <td>42.00</td> <td>-31.92</td> <td>74.00</td> <td>57.11</td> <td>34.07</td> <td>10.62</td> <td>59.72</td> <td>--- --- Peak</td> </tr> <tr> <td>4</td> <td>7422.00</td> <td>37.61</td> <td>-36.39</td> <td>74.00</td> <td>46.79</td> <td>35.50</td> <td>13.62</td> <td>58.30</td> <td>--- --- Peak</td> </tr> <tr> <td>5</td> <td>8349.75</td> <td>34.51</td> <td>-39.47</td> <td>74.00</td> <td>42.37</td> <td>35.60</td> <td>14.49</td> <td>57.93</td> <td>--- --- Peak</td> </tr> <tr> <td>6</td> <td>9277.50</td> <td>33.31</td> <td>-40.69</td> <td>74.00</td> <td>41.18</td> <td>36.07</td> <td>15.51</td> <td>59.45</td> <td>--- --- Peak</td> </tr> </tbody> </table>	Peak	Level	Over	Limit	ReadAntenna	Cable	Preamp	A/Pos	T/Pos	Remark	1	2783.25	54.45	-19.55	74.00	73.14	32.43	8.28	59.40	100 0 Peak	2	3711.00	47.18	-26.82	74.00	64.57	33.00	9.58	59.97	--- --- Peak	3	4638.75	42.00	-31.92	74.00	57.11	34.07	10.62	59.72	--- --- Peak	4	7422.00	37.61	-36.39	74.00	46.79	35.50	13.62	58.30	--- --- Peak	5	8349.75	34.51	-39.47	74.00	42.37	35.60	14.49	57.93	--- --- Peak	6	9277.50	33.31	-40.69	74.00	41.18	36.07	15.51	59.45	--- --- Peak
	Peak	Level	Over	Limit	ReadAntenna	Cable	Preamp	A/Pos	T/Pos	Remark																																																																																																																																				
1	2783.25	53.42	-20.58	74.00	72.11	32.43	8.28	59.40	100 0 Peak																																																																																																																																					
2	3711.00	49.55	-24.45	74.00	66.94	33.00	9.58	59.97	--- --- Peak																																																																																																																																					
3	4638.75	43.19	-31.81	74.00	57.22	34.07	10.62	59.72	--- --- Peak																																																																																																																																					
4	7422.00	39.15	-34.85	74.00	48.33	35.50	13.62	58.30	--- --- Peak																																																																																																																																					
5	8349.75	36.14	-37.86	74.00	43.98	35.60	14.49	57.93	--- --- Peak																																																																																																																																					
6	9277.50	34.17	-39.83	74.00	42.04	36.07	15.51	59.45	--- --- Peak																																																																																																																																					
Peak	Level	Over	Limit	ReadAntenna	Cable	Preamp	A/Pos	T/Pos	Remark																																																																																																																																					
1	2783.25	54.45	-19.55	74.00	73.14	32.43	8.28	59.40	100 0 Peak																																																																																																																																					
2	3711.00	47.18	-26.82	74.00	64.57	33.00	9.58	59.97	--- --- Peak																																																																																																																																					
3	4638.75	42.00	-31.92	74.00	57.11	34.07	10.62	59.72	--- --- Peak																																																																																																																																					
4	7422.00	37.61	-36.39	74.00	46.79	35.50	13.62	58.30	--- --- Peak																																																																																																																																					
5	8349.75	34.51	-39.47	74.00	42.37	35.60	14.49	57.93	--- --- Peak																																																																																																																																					
6	9277.50	33.31	-40.69	74.00	41.18	36.07	15.51	59.45	--- --- Peak																																																																																																																																					



Appendix D. Duty Cycle Plots

Band	Duty Cycle (%)	T(us)	1/T(kHz)	VBW Setting	Duty Factor (dB)
UHF for Ant. (H)	87.18	49275	0.02	10Hz	0.60
UHF for Ant. (V)	87.63	49275	0.02	10Hz	0.57

Ant. (H)

UHF

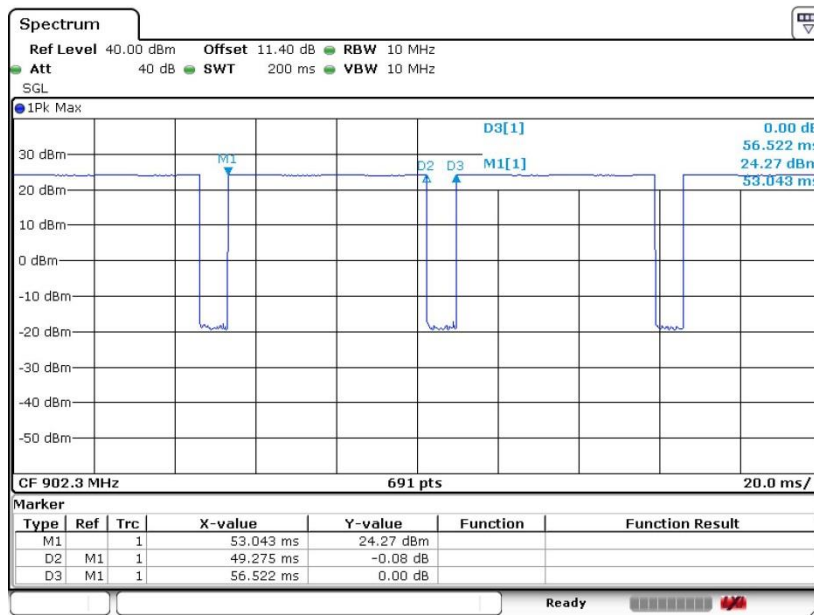

Date: 3.APR.2019 21:22:08



Ant. (V)

UHF

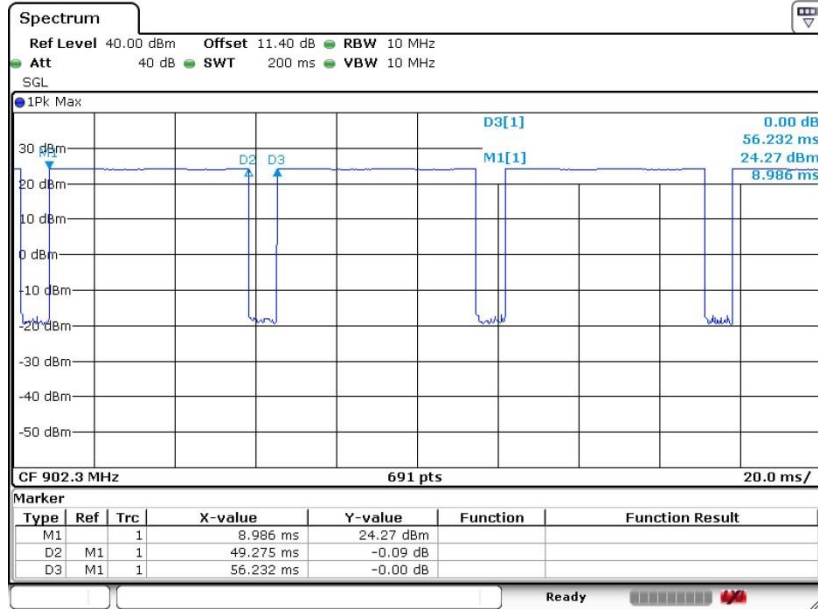

Date: 3.APR.2019 21:22:27