



# Variant FCC RF Test Report

**APPLICANT** : Zebra Technologies Corporation  
**EQUIPMENT** : CONCIERGE HUB  
**BRAND NAME** : Zebra  
**MODEL NAME** : CCHUB1  
**FCC ID** : UZ7CCHUB1  
**STANDARD** : FCC Part 15 Subpart E §15.407  
**CLASSIFICATION** : (NII) Unlicensed National Information Infrastructure

The product was received on Jan. 27, 2016 and testing was completed on Feb. 20, 2016. We, SPORTON INTERNATIONAL INC., would like to declare that the tested sample has been evaluated in accordance with the test procedures and has been in compliance with the applicable technical standards.

The test results in this report apply exclusively to the tested model / sample. Without written approval of SPORTON INTERNATIONAL INC., the test report shall not be reproduced except in full.

Reviewed by: Joseph Lin / Supervisor

Approved by: Jones Tsai / Manager



## **SPORTON INTERNATIONAL INC.**

**No. 52, Hwa Ya 1<sup>st</sup> Rd., Hwa Ya Technology Park, Kwei-Shan District, Tao Yuan City, Taiwan, R.O.C.**

**SPORTON INTERNATIONAL INC.**

TEL : 886-3-327-3456

FAX : 886-3-328-4978

FCC ID : UZ7CCHUB1

Page Number : 1 of 27

Report Issued Date : Mar. 11, 2016

Report Version : Rev. 01

Report Template No.: BU5-FR15EWLB4 Version 1.2



# TABLE OF CONTENTS

**REVISION HISTORY ..... 3**

**SUMMARY OF TEST RESULT ..... 4**

**1 GENERAL DESCRIPTION ..... 5**

    1.1 Applicant ..... 5

    1.2 Manufacturer ..... 5

    1.3 Product Feature of Equipment Under Test ..... 5

    1.4 Product Specification of Equipment Under Test ..... 5

    1.5 Modification of EUT ..... 5

    1.6 Testing Location ..... 6

    1.7 Applicable Standards ..... 6

**2 TEST CONFIGURATION OF EQUIPMENT UNDER TEST ..... 7**

    2.1 Carrier Frequency and Channel ..... 8

    2.2 Pre-Scanned RF Power ..... 9

    2.3 Test Mode ..... 9

    2.4 Connection Diagram of Test System ..... 10

    2.5 EUT Operation Test Setup ..... 10

    2.6 Measurement Results Explanation Example ..... 10

**3 TEST RESULT ..... 11**

    3.1 6dB and 26dB and 99% Occupied Bandwidth Measurement ..... 11

    3.2 Maximum Conducted Output Power Measurement ..... 14

    3.3 Power Spectral Density Measurement ..... 15

    3.4 Unwanted Emissions Measurement ..... 18

    3.5 Frequency Stability Measurement ..... 23

    3.6 Automatically Discontinue Transmission ..... 24

    3.7 Antenna Requirements ..... 25

**4 LIST OF MEASURING EQUIPMENT ..... 26**

**5 UNCERTAINTY OF EVALUATION ..... 27**

**APPENDIX A. CONDUCTED TEST RESULTS**

**APPENDIX B. RADIATED SPURIOUS EMISSION**

**APPENDIX C. RADIATED SPURIOUS EMISSION PLOTS**

**APPENDIX D. SETUP PHOTOGRAPHS**





### SUMMARY OF TEST RESULT

Report Section	FCC Rule	Description	Limit	Result	Remark
3.1	15.403(i)	6dB, 26dB and 99% Occupied Bandwidth	> 500kHz	Pass	-
3.2	15.407(a)	Maximum Conducted Output Power	≤ 30 dBm	Pass	-
3.3	15.407(a)	Power Spectral Density	≤ 30 dBm/500kHz	Pass	-
3.4	15.407(b)	Unwanted Emissions	≤ -17, -27 dBm/MHz & 15.209(a)	Pass	Under limit 8.64 dB at 5715.000 MHz
3.5	15.407(g)	Frequency Stability	Within Operation Band	Pass	-
3.6	15.407(c)	Automatically Discontinue Transmission	Discontinue Transmission	Pass	-
3.7	15.203 & 15.407(a)	Antenna Requirement	N/A	Pass	-



# 1 General Description

## 1.1 Applicant

**Zebra Technologies Corporation**  
1 Zebra Plaza, Holtsville, NY 11742

## 1.2 Manufacturer

**Zebra Technologies Corporation**  
1 Zebra Plaza, Holtsville, NY 11742

## 1.3 Product Feature of Equipment Under Test

Product Feature	
<b>Equipment</b>	CONCIERGE HUB
<b>Brand Name</b>	Zebra
<b>Model Name</b>	CCHUB1
<b>FCC ID</b>	UZ7CCHUB1
<b>EUT supports Radios application</b>	WLAN 11a/b/g/n HT20 Bluetooth v2.1 EDR
<b>MFD</b>	26Aug15
<b>EUT Stage</b>	Identical Prototype

**Remark:** The above EUT's information was declared by manufacturer. Please refer to the specifications or user's manual for more detailed description.

## 1.4 Product Specification of Equipment Under Test

Standards-related Product Specification	
<b>Tx/Rx Channel Frequency Range</b>	5745 MHz ~ 5825 MHz
<b>Maximum Output Power</b>	802.11a : 12.09 dBm / 0.0162 W 802.11n HT20 : 11.93 dBm / 0.0156 W
<b>99% Occupied Bandwidth</b>	802.11a : 17.95 MHz 802.11n HT20 : 19.10 MHz
<b>Type of Modulation</b>	802.11a/n : OFDM (BPSK / QPSK / 16QAM / 64QAM)
<b>Antenna Type</b>	PCB Antenna
<b>Antenna Gain</b>	4.11dBi

## 1.5 Modification of EUT

No modifications are made to the EUT during all test items.



### 1.6 Testing Location

Sporton Lab is accredited to ISO 17025 by Taiwan Accreditation Foundation (TAF code : 1190) and the FCC designation No. TW1022 under the FCC 2.948(e) by Mutual Recognition Agreement (MRA) in FCC Test.

<b>Test Site</b>	SPORTON INTERNATIONAL INC.
<b>Test Site Location</b>	No. 52, Hwa Ya 1 <sup>st</sup> Rd., Hwa Ya Technology Park, Kwei-Shan District, Tao Yuan City, Taiwan, R.O.C. TEL: +886-3-327-3456 FAX: +886-3-328-4978
<b>Test Site No.</b>	<b>Sporton Site No.</b>
	TH02-HY

**Note:** The test site complies with ANSI C63.4 2014 requirement.

<b>Test Site</b>	SPORTON INTERNATIONAL INC.
<b>Test Site Location</b>	No.58, Aly. 75, Ln. 564, Wenhua 3rd Rd., Kwei-Shan District, Tao Yuan City, Taiwan, R.O.C. TEL: +886-3-327-0868 FAX: +886-3-327-0855
<b>Test Site No.</b>	<b>Sporton Site No.</b>
	03CH11-HY

**Note:** The test site complies with ANSI C63.4 2014 requirement.

### 1.7 Applicable Standards

According to the specifications of the manufacturer, the EUT must comply with the requirements of the following standards:

- FCC Part 15 Subpart E
- FCC KDB 789033 D02 General UNII Test Procedures New Rules v01r01
- ANSI C63.10-2013

**Remark:** All test items were verified and recorded according to the standards and without any deviation during the test.



## **2 Test Configuration of Equipment Under Test**

The EUT has been associated with peripherals and configuration operated in a manner tended to maximize its emission characteristics in a typical application. Frequency range investigated: radiated emission (9 kHz to the 10th harmonic of the highest fundamental frequency or to 40 GHz, whichever is lower). For radiated measurement, pre-scanned in three orthogonal panels, X, Y, Z. The worst cases (Z plane) were recorded in this report.

The final configuration from all the combinations and the worst-case data rates were investigated by measuring the maximum power across all the data rates and modulation modes under section 2.2.

Based on the worst configuration found above, the RF power setting is set individually to meet FCC compliance limit for the final conducted and radiated tests shown in section 2.3.



## 2.1 Carrier Frequency and Channel

Frequency Band	Channel	Freq. (MHz)	Channel	Freq. (MHz)
5725-5850 MHz Band 4 (U-NII-3)	149	5745	157	5785
	<b>151</b>	<b>5755</b>	<b>159</b>	<b>5795</b>
	153	5765	161	5805
	155	5775	165	5825

**Note:** The above Frequency and Channel in boldface were 802.11n HT40.





## 2.2 Pre-Scanned RF Power

Preliminary tests were performed in different data rate and data rate associated with the highest power were chosen for full test in the following tables. Final Output Power equals to Measured Output Power adds the duty factor.

Channel	Frequency	5GHz 802.11a RF Power (dBm)							
		OFDM Data Rate							
		6M bps	9M bps	12M bps	18M bps	24M bps	36M bps	48M bps	54M bps
CH 149	5745 MHz	12.09	12.01	11.89	11.81	11.76	11.94	11.86	11.80
CH 157	5785 MHz	11.92	11.90	11.89	11.88	11.86	11.90	11.87	11.90
CH 165	5825 MHz	11.97	11.96	11.91	11.90	11.93	11.95	11.94	11.96

Channel	Frequency	5GHz 802.11n HT20 RF Power (dBm)							
		OFDM Data Rate							
		MCS0	MCS1	MCS2	MCS3	MCS4	MCS5	MCS6	MCS7
CH 149	5745 MHz	11.92	11.90	11.83	11.90	11.89	11.87	11.85	11.88
CH 157	5785 MHz	11.84	11.75	11.80	11.82	11.81	11.78	11.76	11.82
CH 165	5825 MHz	11.93	11.64	11.64	11.68	11.65	11.55	11.64	11.78

## 2.3 Test Mode

Final test mode of conducted test items and radiated spurious emissions are considering the modulation and worse data rates from the power table described in section 2.2.

Modulation	Data Rate
802.11a	6 Mbps
802.11n HT20	MCS0

Ch. #	Band IV : 5725-5850 MHz	
	802.11a	802.11n HT20
L Low	149	149
M Middle	157	157
H High	165	165

## 2.4 Connection Diagram of Test System

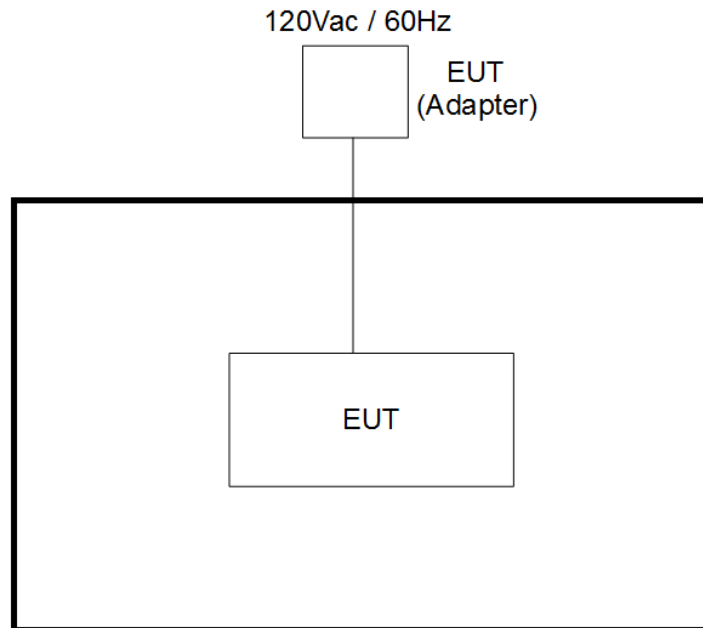

## 2.5 EUT Operation Test Setup

The programmed RF utility “CMD”, is installed in EUT to provide channel selection, power level, data rate and the application type. RF Utility can send transmitting signal for all testing. The RF output power selection is for the setting of RF output power expected by the customer and is going to be fixed on the firmware of the final end product.

## 2.6 Measurement Results Explanation Example

### For all conducted test items:

The offset level is set in the spectrum analyzer to compensate the RF cable loss and attenuator factor between EUT conducted output port and spectrum analyzer. With the offset compensation, the spectrum analyzer reading level is exactly the EUT RF output level.

Example :

The spectrum analyzer offset is derived from RF cable loss and attenuator factor.

*Offset = RF cable loss + attenuator factor.*

Following shows an offset computation example with cable loss 4.2 dB and 10dB attenuator.

$$\begin{aligned} \text{Offset(dB)} &= \text{RF cable loss(dB)} + \text{attenuator factor(dB)}. \\ &= 4.2 + 10 = 14.2 \text{ (dB)} \end{aligned}$$

### 3 Test Result

#### 3.1 6dB and 26dB and 99% Occupied Bandwidth Measurement

##### 3.1.1 Description of 6dB and 26dB and 99% Occupied Bandwidth

The minimum 6 dB bandwidth shall be at least 500 kHz.

26dB and 99% Occupied bandwidth are reporting only.

##### 3.1.2 Measuring Instruments

The measuring equipment is listed in the section 4 of this test report.

##### 3.1.3 Test Procedures

1. The testing follows FCC KDB 789033 D02 General UNII Test Procedures New Rules v01r01.  
Section C) Emission bandwidth for the band 5.725-5.85GHz
2. Set RBW = 100kHz.
3. Set the VBW  $\geq 3 \times$  RBW.
4. Detector = Peak.
5. Trace mode = max hold
6. Measure the maximum width of the emission that is 6 dB down from the peak of the emission.
7. Measure and record the results in the test report.

##### 3.1.4 Test Setup

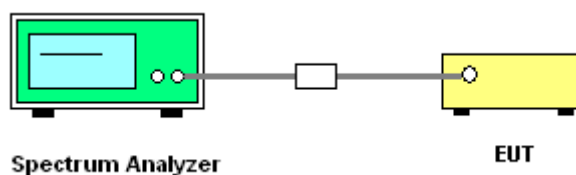



### 3.1.5 Test Result of 6dB Bandwidth

Please refer to Appendix A.

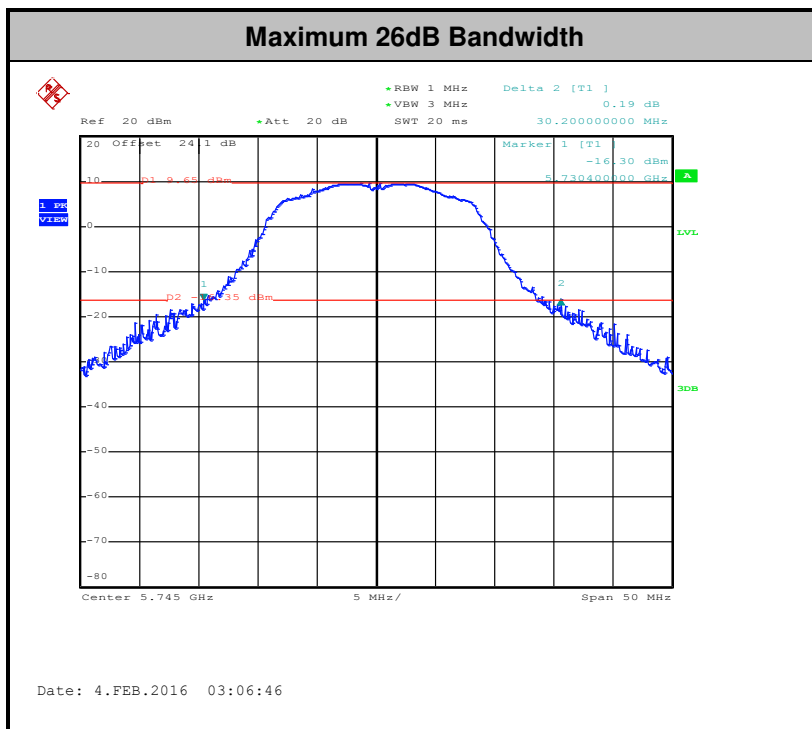
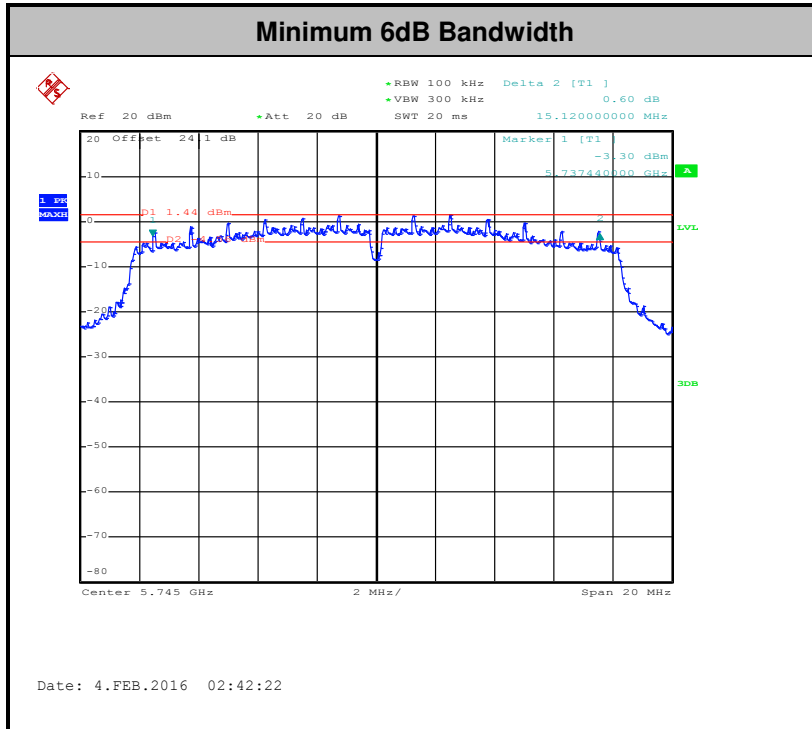

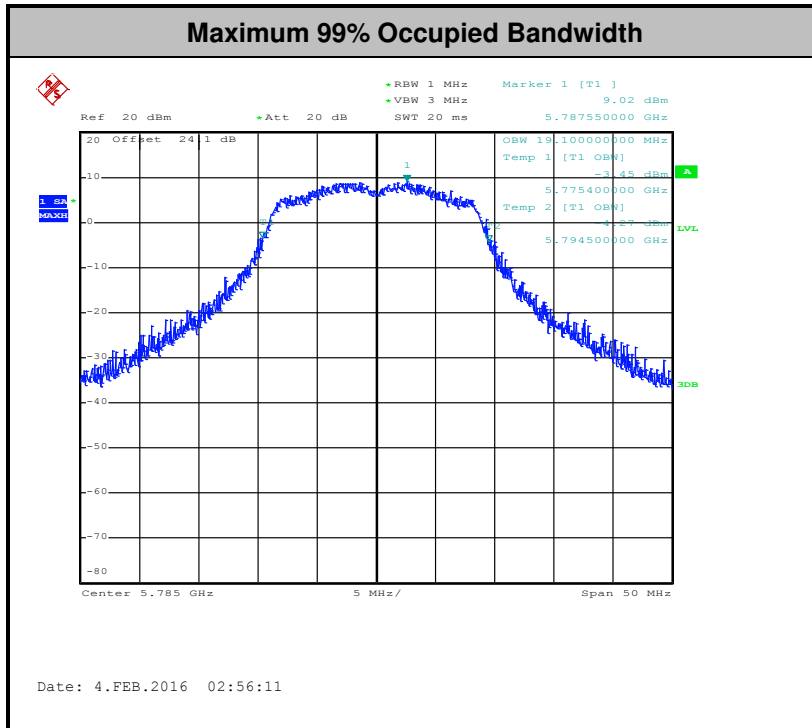

**Note:** The occupied channel bandwidth is maintained within the band of operation for all of the modulations.

## 3.2 Maximum Conducted Output Power Measurement

### 3.2.1 Limit of Maximum Conducted Output Power

For the band 5.725–5.85 GHz, the maximum conducted output power over the frequency band of operation shall not exceed 1 W.

If transmitting antennas of directional gain greater than 6 dBi are used, the peak output power shall be reduced by the amount in dB that the directional gain of the antenna exceeds 6 dBi.

### 3.2.2 Measuring Instruments

The measuring equipment is listed in the section 4 of this test report.

### 3.2.3 Test Procedures

The testing follows Method PM of FCC KDB 789033 D02 General UNII Test Procedures New Rules v01r01.

Method PM (Measurement using an RF average power meter):

1. Measurement is performed using a wideband RF power meter.
2. The EUT is configured to transmit continuously with a consistent duty cycle at its maximum power control level.
3. Measure the average power of the transmitter, and the average power is corrected with duty factor,  $10 \log(1/x)$ , where x is the duty cycle.

### 3.2.4 Test Setup

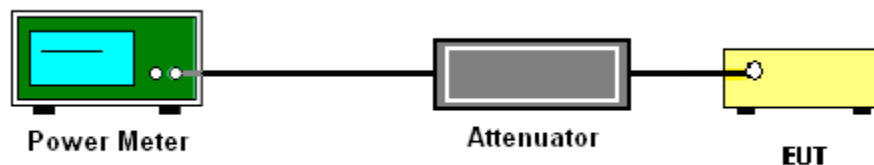

### 3.2.5 Test Result of Maximum Conducted Output Power

Please refer to Appendix A.



### 3.3 Power Spectral Density Measurement

#### 3.3.1 Limit of Power Spectral Density

For the band 5.725–5.85 GHz, the maximum power spectral density shall not exceed 30 dBm in any 500-kHz band.

If transmitting antennas of directional gain greater than 6 dBi are used, the peak output power shall be reduced by the amount in dB that the directional gain of the antenna exceeds 6 dBi.

#### 3.3.2 Measuring Instruments

The measuring equipment is listed in the section 4 of this test report.

#### 3.3.3 Test Procedures

The testing follows FCC KDB 789033 D02 General UNII Test Procedures New Rules v01r01. Section F) Maximum power spectral density.

##### # Method SA-2 #

(trace averaging across on and off times of the EUT transmissions, followed by duty cycle correction).

1. The testing follows Method SA-2 of FCC KDB 789033 D02 General UNII Test Procedures New Rules v01r01.
  - Measure the duty cycle.
  - Set span to encompass the entire emission bandwidth (EBW) of the signal.
  - Set RBW = 300 kHz.
  - Set VBW  $\geq$  1 MHz.
  - Number of points in sweep  $\geq$  2 Span / RBW.
  - Sweep time = auto.
  - Detector = RMS
  - Trace average at least 100 traces in power averaging mode.
  - Add  $10 \log(500\text{kHz}/\text{RBW})$  to the test result.
  - Add  $10 \log(1/x)$ , where  $x$  is the duty cycle, to the measured power in order to compute the average power during the actual transmission times. For example, add  $10 \log(1/0.25) = 6$  dB if the duty cycle is 25 percent.

2. The RF output of EUT was connected to the spectrum analyzer by a low loss cable.
3. Each plot has already offset with cable loss, and attenuator loss. Measure the PPSD and record it.

### 3.3.4 Test Setup

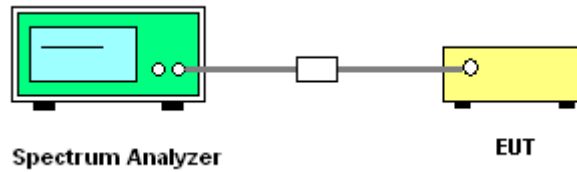





### 3.3.5 Test Result of Power Spectral Density

Please refer to Appendix A.

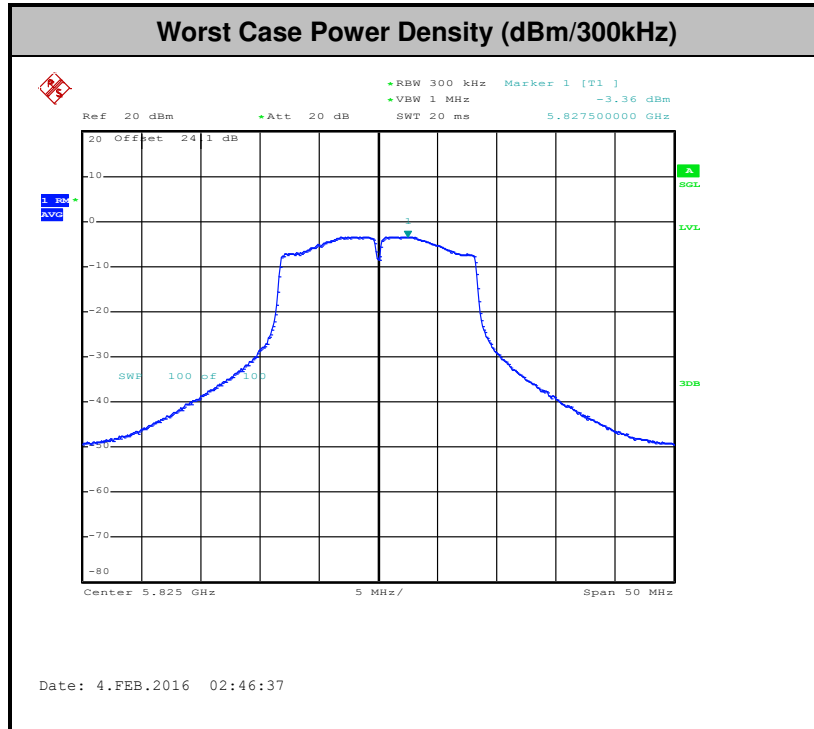



### 3.4 Unwanted Emissions Measurement

This section as specified in FCC Part 15.407(b) is to measure unwanted emissions through radiated measurement for band edge spurious emissions and out of band emissions measurement. The unwanted emissions shall comply with 15.407(b)(1) to (6), and restricted bands per FCC Part15.205.

#### 3.4.1 Limit of Unwanted Emissions

- (1) For transmitters operating in the 5725-5850 MHz band: all emissions within the frequency range from the band edge to 10 MHz above or below the band edge shall not exceed an EIRP of -17 dBm/MHz (78.3dBµV/m); for frequencies 10 MHz or greater above or below the band edge, emissions shall not exceed an EIRP of -27 dBm/MHz (68.3dBµV/m).
- (2) Unwanted spurious emissions fallen in restricted bands per FCC Part15.205 shall comply with the general field strength limits set forth in § 15.209 as below table,

Frequency (MHz)	Field Strength (microvolts/meter)	Measurement Distance (meters)
0.009 – 0.490	2400/F(kHz)	300
0.490 – 1.705	24000/F(kHz)	30
1.705 – 30.0	30	30
30 – 88	100	3
88 – 216	150	3
216 - 960	200	3
Above 960	500	3

**Note:** The following formula is used to convert the EIRP to field strength.

$$E = \frac{1000000\sqrt{30P}}{3} \mu\text{V/m, where P is the eirp (Watts)}$$

EIRP (dBm)	Field Strength at 3m (dBµV/m)
-17	78.3
-27	68.3

- (3) KDB 789033 D02 General UNII Test Procedures New Rules v01r01 G)2)c) As specified in 15.407(b), emissions above 1000 MHz that are outside of the restricted bands are subject to a peak emission limit of -27 dBm/MHz (or -17 dBm/MHz as specified in 15.407(b)(4)). However, an out-of-band emission that complies with both the average and peak limits of 15.209 is not required to satisfy the -27 dBm/MHz or -17 dBm/MHz peak emission limit.



### 3.4.2 Measuring Instruments

The measuring equipment is listed in the section 4 of this test report.

### 3.4.3 Test Procedures

1. The testing follows FCC KDB 789033 D02 General UNII Test Procedures New Rules v01r01. Section G) Unwanted emissions measurement.

(1) Procedure for Unwanted Emissions Measurements Below 1000MHz

- RBW = 120 kHz
- VBW = 300 kHz
- Detector = Peak
- Trace mode = max hold

(2) Procedure for Peak Unwanted Emissions Measurements Above 1000 MHz

- RBW = 1 MHz
- VBW ≥ 3 MHz
- Detector = Peak
- Sweep time = auto
- Trace mode = max hold

(3) Procedures for Average Unwanted Emissions Measurements Above 1000MHz

- RBW = 1 MHz
- VBW = 10 Hz, when duty cycle is no less than 98 percent.
- $VBW \geq 1/T$ , when duty cycle is less than 98 percent where T is the minimum transmission duration over which the transmitter is on and is transmitting at its maximum power control level for the tested mode of operation.

Antenna	Band	Duty Cycle(%)	T(us)	1/T(kHz)	VBW Setting
1	802.11a	98.172	-	-	10Hz
1	802.11n HT20	98.356	-	-	10Hz



2. The EUT was placed on a turntable with 0.8 meter for frequency below 1GHz and 1.5 meter for frequency above 1GHz respectively above ground.
3. The EUT was set 3 meters from the interference receiving antenna which was mounted on the top of a variable height antenna tower.
4. The antenna is a broadband antenna and its height is adjusted between one meter and four meters above ground to find the maximum value of the field strength for both horizontal polarization and vertical polarization of the antenna.
5. For each suspected emission, the EUT was arranged to its worst case and then adjust the antenna tower (from 1 m to 4 m) and turntable (from 0 degree to 360 degrees) to find the maximum reading.
6. For testing below 1GHz, if the emission level of the EUT in peak mode was 3 dB lower than the limit specified, then peak values of EUT will be reported, otherwise, the emissions will be repeated one by one using the CISPR quasi-peak method and reported.
7. For testing above 1GHz, the emission level of the EUT in peak mode was 20dB lower than average limit (that means the emission level in average mode also complies with the limit in average mode), then peak values of EUT will be reported, otherwise, the emissions will be measured in average mode again and reported.

### 3.4.4 Test Setup

For radiated emissions below 30MHz

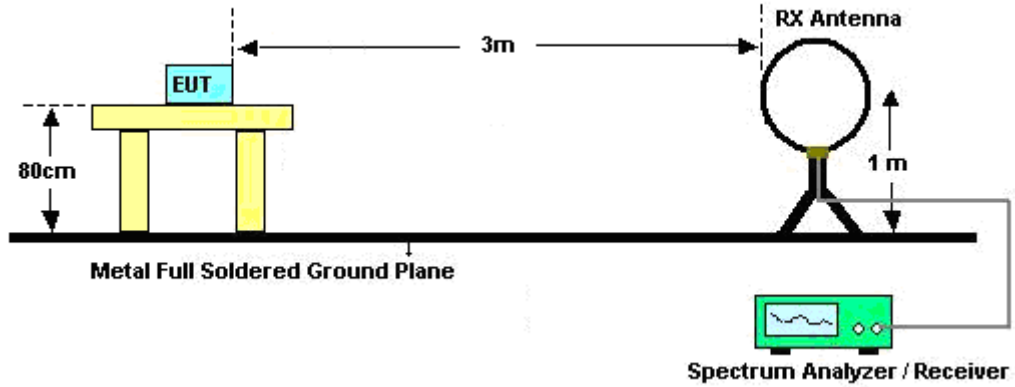

For radiated emissions from 30MHz to 1GHz

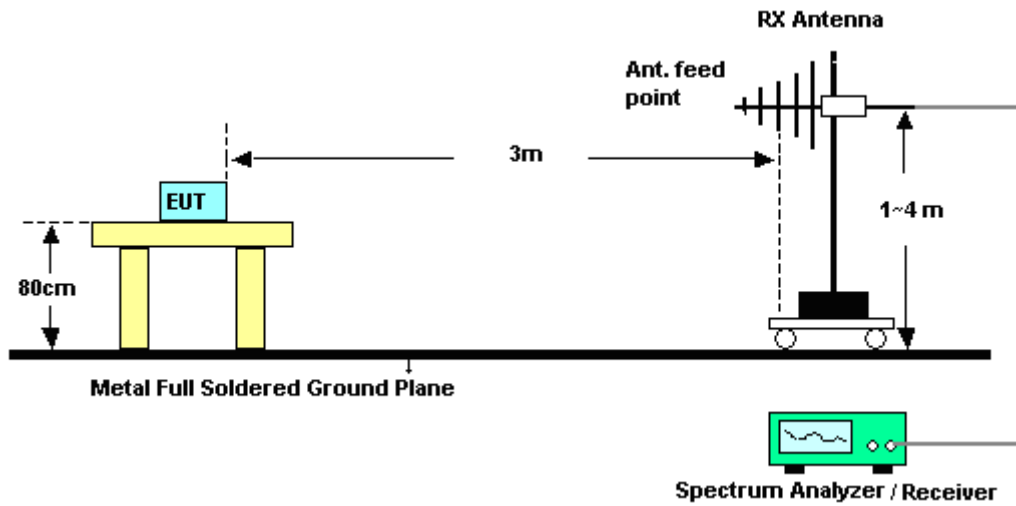

For radiated emissions above 1GHz

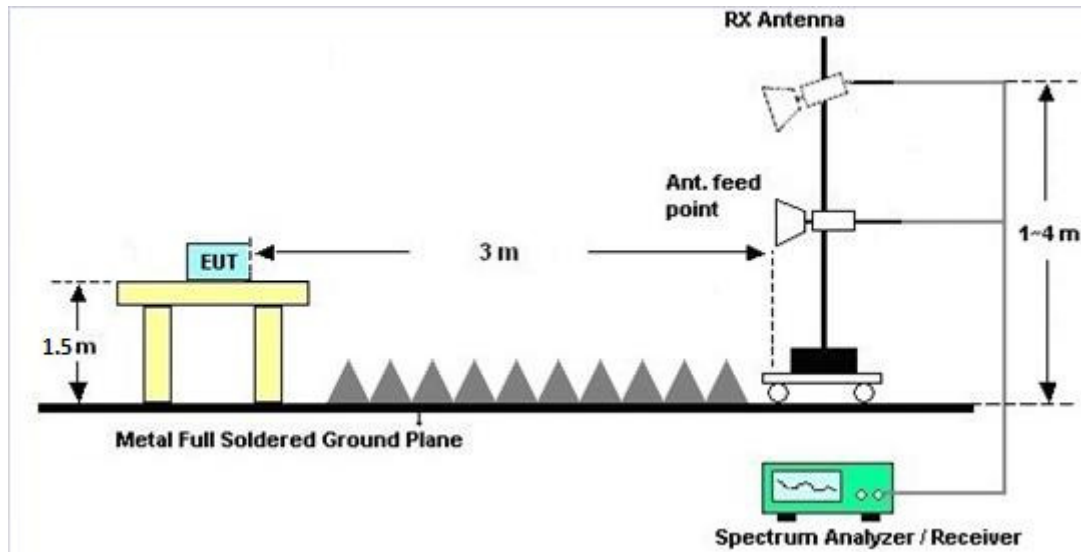

### 3.4.5 Test Results of Radiated Emissions (9 kHz ~ 30 MHz)

The low frequency, which started from 9 kHz to 30MHz, was pre-scanned and the result which was 20dB lower than the limit line per 15.31(o) was not reported.

### 3.4.6 Test Result of Radiated Band Edges

Please refer to Appendix B and C.

### 3.4.7 Test Result of Unwanted Radiated Emission (30MHz ~ 10th Harmonic)

Please refer to Appendix B and C.

### 3.5 Frequency Stability Measurement

#### 3.5.1 Limit of Frequency Stability

Manufacturers of U-NII devices are responsible for ensuring frequency stability such that an emission is maintained within the band of operation under all conditions of normal operation as specified in the user's manual.

#### 3.5.2 Measuring Instruments

The measuring equipment is listed in the section 4 of this test report.

#### 3.5.3 Test Procedures

1. To ensure emission at the band edge is maintained within the authorized band, those values shall be measured by radiation emissions at upper and lower frequency points, and finally compensated by frequency deviation as procedures below.
2. The EUT was operated at the maximum output power, and connected to the spectrum analyzer, which is set to maximum hold function and peak detector. The peak value of the power envelope was measured and noted. The upper and lower frequency points were respectively measured relatively 10dB lower than the measured peak value.
3. The frequency deviation was calculated by adding the upper frequency point and the lower frequency point divided by two. Those detailed values of frequency deviation are provided in table below.

#### 3.5.4 Test Setup

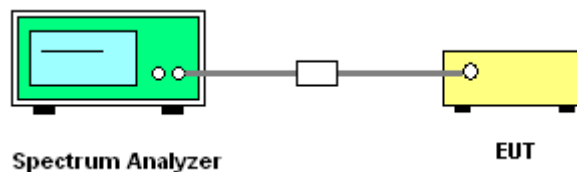

#### 3.5.5 Test Result of Frequency Stability

Please refer to Appendix A.



## **3.6 Automatically Discontinue Transmission**

### **3.6.1 Limit of Automatically Discontinue Transmission**

The device shall automatically discontinue transmission in case of either absence of information to transmit or operational failure. These provisions are not intended to preclude the transmission of control or signaling information or the use of repetitive codes used by certain digital technologies to complete frame or burst intervals. Applicants shall include in their application for equipment authorization to describe how this requirement is met.

### **3.6.2 Measuring Instruments**

The measuring equipment is listed in the section 4 of this test report.

### **3.6.3 Test Result of Automatically Discontinue Transmission**

While the EUT is not transmitting any information, the EUT can automatically discontinue transmission and become standby mode for power saving. The EUT can detect the controlling signal of ACK message transmitting from remote device and verify whether it shall resend or discontinue transmission.





## **3.7 Antenna Requirements**

### **3.7.1 Standard Applicable**

According to FCC 47 CFR Section 15.407(a)(1)(2) ,if transmitting antenna directional gain is greater than 6 dBi, both the peak transmit power and the peak power spectral density shall be reduced by the amount in dB that the directional gain of the antenna exceeds 6 dBi.

### **3.7.2 Antenna Anti-Replacement Construction**

An embedded-in antenna design is used.

### **3.7.3 Antenna Gain**

The antenna gain is less than 6 dBi. Therefore, it is not necessary to reduce maximum peak output power limit.



## 4 List of Measuring Equipment

Instrument	Manufacturer	Model No.	Serial No.	Characteristics	Calibration Date	Test Date	Due Date	Remark
Power Meter	Anritsu	ML2495A	1036004	300MHz~40GHz	Jul. 29, 2015	Feb. 04, 2016	Jul. 28, 2016	Conducted (TH02-HY)
Power Sensor	Anritsu	MA2411B	1027253	300MHz~40GHz	Jul. 29, 2015	Feb. 04, 2016	Jul. 28, 2016	Conducted (TH02-HY)
Spectrum Analyzer	Rohde & Schwarz	FSP40	100055	9kHz~40GHz	Jun. 18, 2015	Feb. 04, 2016	Jun. 17, 2016	Conducted (TH02-HY)
Thermal Chamber	Ten Billion	TTH-D3SP	TBN-930701	N/A	Jul. 16, 2015	Feb. 04, 2016	Jul. 15, 2016	Conducted (TH02-HY)
Loop Antenna	Rohde & Schwarz	HFH2-Z2	100315	9 kHz~30 MHz	Sep. 02, 2015	Feb. 19, 2016~ Feb. 20, 2016	Sep. 01, 2016	Radiation (03CH11-HY)
Amplifier	SONOMA	310N	187312	9kHz~1GHz	Nov. 20, 2015	Feb. 19, 2016~ Feb. 20, 2016	Nov. 19, 2016	Radiation (03CH11-HY)
Bilog Antenna	TESEQ	CBL 6111D	35414	30MHz~1GHz	Nov. 17, 2015	Feb. 19, 2016~ Feb. 20, 2016	Nov. 16, 2016	Radiation (03CH11-HY)
Horn Antenna	SCHWARZBECK	BBHA 9120 D	9120D-1326	1GHz ~ 18GHz	Oct. 08, 2015	Feb. 19, 2016~ Feb. 20, 2016	Oct. 07, 2016	Radiation (03CH11-HY)
Preamplifier	Keysight	83017A	MY53270080	1GHz~26.5GHz	Nov. 19, 2015	Feb. 19, 2016~ Feb. 20, 2016	Nov. 18, 2016	Radiation (03CH11-HY)
Preamplifier	MITEQ	AMF-7D-0010 1800-30-10P	1902247	1GHz~18GHz	Jul. 01, 2015	Feb. 19, 2016~ Feb. 20, 2016	Jun. 30, 2016	Radiation (03CH11-HY)
Spectrum Analyzer	Keysight	N9010A	MY54200486	10Hz ~ 44GHZ	Sep. 24, 2015	Feb. 19, 2016~ Feb. 20, 2016	Sep. 23, 2016	Radiation (03CH11-HY)
Antenna Mast	EMEC	AM-BS-4500-B	N/A	1~4m	N/A	Feb. 19, 2016~ Feb. 20, 2016	N/A	Radiation (03CH11-HY)
Turn Table	EMEC	TT 2000	N/A	0-360 degree	N/A	Feb. 19, 2016~ Feb. 20, 2016	N/A	Radiation (03CH11-HY)
SHF-EHF Horn Antenna	SCHWARZBECK	BBHA 9170	BBHA917058 4	18GHz- 40GHz	Nov. 02, 2015	Feb. 19, 2016~ Feb. 20, 2016	Nov. 01, 2016	Radiation (03CH11-HY)
Preamplifier	MITEQ	JS44-1800400 0-33-8P	1840917	18GHz ~ 40GHz	Jun. 02, 2015	Feb. 19, 2016~ Feb. 20, 2016	Jun. 01, 2016	Radiation (03CH11-HY)



## 5 Uncertainty of Evaluation

### Uncertainty of Radiated Emission Measurement (30 MHz ~ 1000 MHz)

Measuring Uncertainty for a Level of Confidence of 95% ( $U = 2Uc(y)$ )	4.90
---	------



## **Appendix A. Conducted Test Results**

Test Engineer:	Osolemic Chang	Temperature:	21~25	°C
Test Date:	2016/2/4	Relative Humidity:	51~54	%

**TEST RESULTS DATA**  
**6dB and 26dB EBW and 99% OBW**

Band IV									
Mod.	Data Rate	NTX	CH.	Freq. (MHz)	99% Bandwidth (MHz)	26 dB Bandwidth (MHz)	6 dB Bandwidth (MHz)	6dB Bandwidth min. Limit (MHz)	Pass/Fail
11a	6Mbps	1	149	5745	17.95	28.2	15.12	0.5	Pass
11a	6Mbps	1	157	5785	17.85	27.5	15.16	0.5	Pass
11a	6Mbps	1	165	5825	17.75	29	15.12	0.5	Pass
HT20	MCS 0	1	149	5745	18.9	30.2	15.12	0.5	Pass
HT20	MCS 0	1	157	5785	19.1	29.3	15.12	0.5	Pass
HT20	MCS 0	1	165	5825	19.05	30.1	15.16	0.5	Pass

**TEST RESULTS DATA**  
**Average Power Table**

Band IV										
Mod.	Data Rate	NTX	CH.	Freq. (MHz)	Duty Factor (dB)	Average Conducted Power (dBm)	FCC Conducted Power Limit (dBm)	DG (dBi)		Pass/Fail
11a	6Mbps	1	149	5745	0.08	12.09	30.00	0.00		Pass
11a	6Mbps	1	157	5785	0.08	11.92	30.00	0.00		Pass
11a	6Mbps	1	165	5825	0.08	11.97	30.00	0.00		Pass
HT20	MCS 0	1	149	5745	0.07	11.92	30.00	0.00		Pass
HT20	MCS 0	1	157	5785	0.07	11.84	30.00	0.00		Pass
HT20	MCS 0	1	165	5825	0.07	11.93	30.00	0.00		Pass

**TEST RESULTS DATA**  
**Power Spectral Density**

Band IV										
Mod.	Data Rate	N <sub>TX</sub>	CH.	Freq. (MHz)	Duty Factor (dB)	10log (500kHz /RBW) Factor (dB)	Average Power Density (dBm/500kHz)	Average PSD Limit (dBm/500kHz)	DG (dBi)	Pass/Fail
11a	6Mbps	1	149	5745	0.08	2.22	-1.24	30.00	0.00	Pass
11a	6Mbps	1	157	5785	0.08	2.22	-1.20	30.00	0.00	Pass
11a	6Mbps	1	165	5825	0.08	2.22	-1.06	30.00	0.00	Pass
HT20	MCS 0	1	149	5745	0.07	2.22	-1.44	30.00	0.00	Pass
HT20	MCS 0	1	157	5785	0.07	2.22	-1.66	30.00	0.00	Pass
HT20	MCS 0	1	165	5825	0.07	2.22	-1.66	30.00	0.00	Pass



**TEST RESULTS DATA**  
**Frequency Stability**

Band IV										
Mod.	Data Rate	NTX	CH.	Freq. (MHz)	Center Frequency (MHz)	Frequency Deviation (MHz)	Frequency Stability (ppm)	Temperature (°C)	Voltage (V)	Note
11a	6M bps	1	149	5745	5744.950	-0.050	-8.70	20	3.2	
11a	6M bps	1	149	5745	5745.000	0.000	0.00	20	4.2	
11a	6M bps	1	149	5745	5745.000	0.000	0.00	20	3.7	
11a	6M bps	1	149	5745	5745.000	0.000	0.00	-30	3.7	
11a	6M bps	1	149	5745	5745.000	0.000	0.00	50	3.7	



## Appendix B. Radiated Spurious Emission

5725~5850MHz

WIFI 802.11a (Band Edge @ 3m)

WIFI Ant.	Note	Frequency	Level	Over Limit	Limit Line	Read Level	Antenna Factor	Cable Loss	Preamp Factor	Ant Pos	Table Pos	Peak Avg.	Pol.	
1		( MHz )	( dBμV/m )	( dB )	( dBμV/m )	( dBμV )	( dB/m )	( dB )	( dB )	( cm )	( deg )	( P/A )	( H/V )	
802.11a CH 149 5745MHz		5711.8	56.6	-17.4	74	47.23	32.29	10.65	33.57	191	127	P	H	
		5724.68	62.9	-15.4	78.3	53.51	32.31	10.65	33.57	191	127	P	H	
		5715	44.8	-9.2	54	35.43	32.29	10.65	33.57	191	127	A	H	
	*	5745	106	-	-	96.6	32.34	10.63	33.57	191	127	P	H	
	*	5745	99.58	-	-	90.18	32.34	10.63	33.57	191	127	A	H	
														H
														H
														H
			5712.36	50.01	-23.99	74	40.64	32.29	10.65	33.57	400	117	P	V
			5725	59.02	-19.28	78.3	49.63	32.31	10.65	33.57	400	117	P	V
			5715	41.12	-12.88	54	31.75	32.29	10.65	33.57	400	117	A	V
	*		5745	101.45	-	-	92.05	32.34	10.63	33.57	400	117	P	V
	*		5745	95.61	-	-	86.21	32.34	10.63	33.57	400	117	A	V
														V
														V
													V	



WIFI Ant. 1	Note	Frequency ( MHz )	Level ( dBμV/m )	Over Limit ( dB )	Limit Line ( dBμV/m )	Read Level ( dBμV )	Antenna Factor ( dB/m )	Cable Loss ( dB )	Preamp Factor ( dB )	Ant Pos ( cm )	Table Pos ( deg )	Peak Avg. (P/A)	Pol. (H/V)
802.11a CH 157 5785MHz		5700.28	49.03	-24.97	74	39.67	32.27	10.65	33.56	191	123	P	H
		5720.04	48.62	-29.68	78.3	39.23	32.31	10.65	33.57	191	123	P	H
		5685.64	40.34	-13.66	54	30.96	32.27	10.67	33.56	191	123	A	H
	*	5785	105.14	-	-	95.73	32.39	10.61	33.59	191	123	P	H
	*	5785	98.55	-	-	89.14	32.39	10.61	33.59	191	123	A	H
		5852.64	49.01	-29.29	78.3	39.36	32.48	10.78	33.61	191	123	P	H
		5868.16	49.68	-24.32	74	39.85	32.51	10.94	33.62	191	123	P	H
		5865.36	39.8	-14.2	54	29.97	32.51	10.94	33.62	191	123	A	H
		5695.4	48.5	-25.5	74	39.12	32.27	10.67	33.56	393	112	P	V
		5724.44	47.14	-31.16	78.3	37.75	32.31	10.65	33.57	393	112	P	V
		5685.24	39.3	-14.7	54	29.92	32.27	10.67	33.56	393	112	A	V
	*	5785	101.15	-	-	91.74	32.39	10.61	33.59	393	112	P	V
	*	5785	92.02	-	-	82.61	32.39	10.61	33.59	393	112	A	V
		5857.28	49.64	-28.66	78.3	39.96	32.51	10.78	33.61	393	112	P	V
		5873.52	49.65	-24.35	74	39.8	32.53	10.94	33.62	393	112	P	V
		5876.88	39.44	-14.56	54	29.59	32.53	10.94	33.62	393	112	A	V



WiFi Ant. 1	Note	Frequency ( MHz )	Level ( dBμV/m )	Over Limit ( dB )	Limit Line ( dBμV/m )	Read Level ( dBμV )	Antenna Factor ( dB/m )	Cable Loss ( dB )	Preamp Factor ( dB )	Ant Pos ( cm )	Table Pos ( deg )	Peak Avg. ( P/A )	Pol. ( H/V )	
802.11a CH 165 5825MHz	*	5825	103.62	-	-	93.98	32.46	10.78	33.6	184	126	P	H	
	*	5825	95.28	-	-	85.64	32.46	10.78	33.6	184	126	A	H	
		5851.68	52.13	-26.17	78.3	42.48	32.48	10.78	33.61	184	126	P	H	
		5876	50.22	-23.78	74	40.37	32.53	10.94	33.62	184	126	P	H	
		5860	40.98	-13.02	54	31.31	32.51	10.78	33.62	184	126	A	H	
														H
														H
														H
	*	5825	100.33	-	-	90.69	32.46	10.78	33.6	390	112	P	V	
	*	5825	91.64	-	-	82	32.46	10.78	33.6	390	112	A	V	
		5850.48	50.28	-28.02	78.3	40.63	32.48	10.78	33.61	390	112	P	V	
		5870.88	49.12	-24.88	74	39.27	32.53	10.94	33.62	390	112	P	V	
		5860	39.93	-14.07	54	30.26	32.51	10.78	33.62	390	112	A	V	
														V
														V
														V
													V	
<b>Remark</b>	1. No other spurious found. 2. All results are PASS against Peak and Average limit line.													



5725~5850MHz

WIFI 802.11a (Harmonic @ 3m)

WIFI Ant. 1	Note	Frequency ( MHz )	Level ( dBμV/m )	Over Limit ( dB )	Limit Line ( dBμV/m )	Read Level ( dBμV )	Antenna Factor ( dB/m )	Cable Loss ( dB )	Preamp Factor ( dB )	Ant Pos ( cm )	Table Pos ( deg )	Peak Avg. ( P/A )	Pol. ( H/V )	
802.11a CH 149 5745MHz		11490	41.86	-32.14	74	52.1	39.91	15.59	65.74	100	0	P	H	
		17235	51.25	-22.75	74	55.73	41	18.6	64.08	147	100	P	H	
		17235	42.51	-11.49	54	46.99	41	18.6	64.08	147	100	A	H	
													H	
			11490	43.44	-30.56	74	53.68	39.91	15.59	65.74	100	0	P	V
			17235	50.37	-23.63	74	54.85	41	18.6	64.08	100	0	P	V
														V
802.11a CH 157 5785MHz		11570	43.43	-30.57	74	53.69	39.76	15.64	65.66	100	0	P	H	
		17355	49.81	-24.19	74	54.03	41.35	18.65	64.22	100	0	P	H	
													H	
													H	
			11570	43.16	-30.84	74	53.42	39.76	15.64	65.66	100	0	P	V
			17355	50.52	-23.48	74	54.74	41.35	18.65	64.22	100	0	P	V
														V
802.11a CH 165 5825MHz		11650	42.47	-31.53	74	52.78	39.62	15.69	65.62	100	0	P	H	
		17475	51.14	-22.86	74	55.1	41.7	18.7	64.36	137	105	P	H	
		17475	41.45	-12.55	54	45.41	41.7	18.7	64.36	137	105	A	H	
													H	
			11650	42.16	-31.84	74	52.47	39.62	15.69	65.62	100	0	P	V
			17475	47.25	-26.75	74	51.21	41.7	18.7	64.36	100	0	P	V
														V
Remark	1. No other spurious found. 2. All results are PASS against Peak and Average limit line.													



5725~5850MHz

WIFI 802.11n HT20 (Band Edge @ 3m)

WIFI Ant. 1	Note	Frequency ( MHz )	Level ( dBμV/m )	Over Limit ( dB )	Limit Line ( dBμV/m )	Read Level ( dBμV )	Antenna Factor ( dB/m )	Cable Loss ( dB )	Preamp Factor ( dB )	Ant Pos ( cm )	Table Pos ( deg )	Peak Avg. ( P/A )	Pol. ( H/V )	
802.11n HT20 CH 149 5745MHz		5715	55.83	-18.17	74	46.46	32.29	10.65	33.57	189	125	P	H	
		5725	65.41	-12.89	78.3	56.02	32.31	10.65	33.57	189	125	P	H	
		5715	45.36	-8.64	54	35.99	32.29	10.65	33.57	189	125	A	H	
	*	5745	105.73	-	-	96.33	32.34	10.63	33.57	189	125	P	H	
	*	5745	97.2	-	-	87.8	32.34	10.63	33.57	189	125	A	H	
														H
														H
														H
			5713.32	51.54	-22.46	74	42.17	32.29	10.65	33.57	400	105	P	V
			5724.84	63.21	-15.09	78.3	53.82	32.31	10.65	33.57	400	105	P	V
			5715	41.75	-12.25	54	32.38	32.29	10.65	33.57	400	105	A	V
	*		5745	102.91	-	-	93.51	32.34	10.63	33.57	400	105	P	V
	*		5745	95.34	-	-	85.94	32.34	10.63	33.57	400	105	A	V
														V
														V
													V	



WIFI Ant. 1	Note	Frequency ( MHz )	Level ( dBμV/m )	Over Limit ( dB )	Limit Line ( dBμV/m )	Read Level ( dBμV )	Antenna Factor ( dB/m )	Cable Loss ( dB )	Preamp Factor ( dB )	Ant Pos ( cm )	Table Pos ( deg )	Peak Avg. (P/A)	Pol. (H/V)
802.11n HT20 CH 157 5785MHz		5691.8	49.08	-24.92	74	39.7	32.27	10.67	33.56	188	125	P	H
		5722.6	48.44	-29.86	78.3	39.05	32.31	10.65	33.57	188	125	P	H
		5685.8	40.19	-13.81	54	30.81	32.27	10.67	33.56	188	125	A	H
	*	5785	103.88	-	-	94.47	32.39	10.61	33.59	188	125	P	H
	*	5785	96.35	-	-	86.94	32.39	10.61	33.59	188	125	A	H
		5851.36	49.61	-28.69	78.3	39.96	32.48	10.78	33.61	188	125	P	H
		5860.56	49.48	-24.52	74	39.65	32.51	10.94	33.62	188	125	P	H
		5861.92	39.81	-14.19	54	29.98	32.51	10.94	33.62	188	125	A	H
		5693.32	48.79	-25.21	74	39.41	32.27	10.67	33.56	389	181	P	V
		5715.4	47.03	-31.27	78.3	37.66	32.29	10.65	33.57	389	181	P	V
		5685.8	38.88	-15.12	54	29.5	32.27	10.67	33.56	389	181	A	V
	*	5785	99.14	-	-	89.73	32.39	10.61	33.59	389	181	P	V
	*	5785	91.74	-	-	82.33	32.39	10.61	33.59	389	181	A	V
		5857.44	47.52	-30.78	78.3	37.84	32.51	10.78	33.61	389	181	P	V
		5860.96	48.98	-25.02	74	39.15	32.51	10.94	33.62	389	181	P	V
	5867.92	39.36	-14.64	54	29.53	32.51	10.94	33.62	389	181	A	V	



WIFI Ant. 1	Note	Frequency ( MHz )	Level ( dBμV/m )	Over Limit ( dB )	Limit Line ( dBμV/m )	Read Level ( dBμV )	Antenna Factor ( dB/m )	Cable Loss ( dB )	Preamp Factor ( dB )	Ant Pos ( cm )	Table Pos ( deg )	Peak Avg. ( P/A )	Pol. ( H/V )	
802.11n HT20 CH 165 5825MHz	*	5825	102.95	-	-	93.31	32.46	10.78	33.6	287	123	P	H	
	*	5825	94.04	-	-	84.4	32.46	10.78	33.6	287	123	A	H	
		5850.16	51.65	-26.65	78.3	42	32.48	10.78	33.61	287	123	P	H	
		5865.44	49.99	-24.01	74	40.16	32.51	10.94	33.62	287	123	P	H	
		5860	41.02	-12.98	54	31.35	32.51	10.78	33.62	287	123	A	H	
														H
														H
														H
	*	5825	98.31	-	-	88.67	32.46	10.78	33.6	318	185	P	V	
	*	5825	90.77	-	-	81.13	32.46	10.78	33.6	318	185	A	V	
		5852.64	49.71	-28.59	78.3	40.06	32.48	10.78	33.61	318	185	P	V	
		5872.8	48.56	-25.44	74	38.71	32.53	10.94	33.62	318	185	P	V	
		5860.4	39.93	-14.07	54	30.1	32.51	10.94	33.62	318	185	A	V	
														V
														V
													V	
<b>Remark</b>	1. No other spurious found. 2. All results are PASS against Peak and Average limit line.													





5725~5850MHz

WIFI 802.11n HT20 (Harmonic @ 3m)

WIFI Ant. 1	Note	Frequency ( MHz )	Level ( dBμV/m )	Over Limit ( dB )	Limit Line ( dBμV/m )	Read Level ( dBμV )	Antenna Factor ( dB/m )	Cable Loss ( dB )	Preamp Factor ( dB )	Ant Pos ( cm )	Table Pos ( deg )	Peak Avg. ( P/A )	Pol. ( H/V )	
802.11n HT20 CH 149 5745MHz		11490	43.07	-30.93	74	53.31	39.91	15.59	65.74	100	0	P	H	
		17235	49.67	-24.33	74	54.15	41	18.6	64.08	100	0	P	H	
													H	
													H	
			11490	42.73	-31.27	74	52.97	39.91	15.59	65.74	100	0	P	V
			17235	50.26	-23.74	74	54.74	41	18.6	64.08	100	0	P	V
														V
802.11n HT20 CH 157 5785MHz		11570	43.15	-30.85	74	53.41	39.76	15.64	65.66	100	0	P	H	
		17355	50.22	-23.78	74	54.44	41.35	18.65	64.22	100	0	P	H	
													H	
													H	
			11570	42.73	-31.27	74	52.99	39.76	15.64	65.66	100	0	P	V
			17355	49.44	-24.56	74	53.66	41.35	18.65	64.22	100	0	P	V
														V
802.11n HT20 CH 165 5825MHz		11650	42.34	-31.66	74	52.65	39.62	15.69	65.62	100	0	P	H	
		14745	47.65	-26.35	74	54.55	40.9	17.55	65.35	100	0	P	H	
													H	
													H	
			11650	42.18	-31.82	74	52.49	39.62	15.69	65.62	100	0	P	V
			17475	48.74	-25.26	74	52.7	41.7	18.7	64.36	100	0	P	V
														V
Remark	1. No other spurious found.													
	2. All results are PASS against Peak and Average limit line.													



Emission below 1GHz

5GHz WIFI 802.11n HT20 (LF @ 3m)

WIFI	Note	Frequency	Level	Over	Limit	Read	Antenna	Cable	Preamp	Ant	Table	Peak	Pol.	
Ant.				Limit	Line	Level	Factor	Loss	Factor	Pos	Pos	Avg.		
1		( MHz )	( dBμV/m )	( dB )	( dBμV/m )	( dBμV )	( dB/m )	( dB )	( dB )	( cm )	( deg )	( P/A )	( H/V )	
5GHz 802.11n HT20 LF		148.53	23.16	-20.34	43.5	35.77	17.49	1.68	31.78			P	H	
		230.07	27.04	-18.96	46	39.93	16.9	1.98	31.77			P	H	
		270.84	32.4	-13.6	46	42.75	19.29	2.13	31.77			P	H	
		433.7	32.01	-13.99	46	37.15	23.01	3.68	31.83			P	H	
		521.9	32.14	-13.86	46	36.71	24.4	2.95	31.92			P	H	
		742.4	34.89	-11.11	46	35.72	27.54	3.62	31.99	341	157	P	H	
													H	
													H	
													H	
													H	
													H	
													H	
													H	
			30	30.65	-9.35	40	35.85	25.7	0.93	31.83	197	341	P	V
			65.64	29.13	-10.87	40	47.55	12.2	1.17	31.79			P	V
			98.31	23.45	-20.05	43.5	38.2	15.86	1.17	31.78			P	V
			477.8	30.45	-15.55	46	35.71	23.75	2.86	31.87			P	V
			787.2	32.02	-13.98	46	32.11	28.15	3.7	31.94			P	V
			942.6	33.56	-12.44	46	30.35	30.41	3.89	31.09			P	V
													V	
												V		
												V		
												V		
												V		
												V		
Remark	1. No other spurious found. 2. All results are PASS against limit line.													



**Note symbol**

*	<b>Fundamental Frequency</b> which can be ignored. However, the level of any unwanted emissions shall not exceed the level of the fundamental frequency.
!	Test result is <b>over limit</b> line.
P/A	<b>Peak</b> or <b>Average</b>
H/V	<b>Horizontal</b> or <b>Vertical</b>



A calculation example for radiated spurious emission is shown as below:

WIFI	Note	Frequency	Level	Over	Limit	Read	Antenna	Cable	Preamp	Ant	Table	Peak	Pol.
Ant.				Limit	Line	Level	Factor	Loss	Factor	Pos	Pos	Avg.	
1		( MHz )	( dBμV/m )	( dB )	( dBμV/m )	( dBμV )	( dB/m )	( dB )	( dB )	( cm )	( deg )	( P/A )	( H/V )
802.11b		2390	55.45	-18.55	74	54.51	32.22	4.58	35.86	103	308	P	H
CH 01													
2412MHz		2390	43.54	-10.46	54	42.6	32.22	4.58	35.86	103	308	A	H

- Level(dBμV/m) =  
Antenna Factor(dB/m) + Cable Loss(dB) + Read Level(dBμV) - Preamp Factor(dB)
- Over Limit(dB) = Level(dBμV/m) – Limit Line(dBμV/m)

**For Peak Limit @ 2390MHz:**

- Level(dBμV/m)  
= Antenna Factor(dB/m) + Cable Loss(dB) + Read Level(dBμV) - Preamp Factor(dB)  
= 32.22(dB/m) + 4.58(dB) + 54.51(dBμV) – 35.86 (dB)  
= 55.45 (dBμV/m)
- Over Limit(dB)  
= Level(dBμV/m) – Limit Line(dBμV/m)  
= 55.45(dBμV/m) – 74(dBμV/m)  
= -18.55(dB)

**For Average Limit @ 2390MHz:**

- Level(dBμV/m)  
= Antenna Factor(dB/m) + Cable Loss(dB) + Read Level(dBμV) - Preamp Factor(dB)  
= 32.22(dB/m) + 4.58(dB) + 42.6(dBμV) – 35.86 (dB)  
= 43.54 (dBμV/m)
- Over Limit(dB)  
= Level(dBμV/m) – Limit Line(dBμV/m)  
= 43.54(dBμV/m) – 54(dBμV/m)  
= -10.46(dB)

**Both peak and average measured complies with the limit line, so test result is “PASS”.**



## **Appendix C. Radiated Spurious Emission Plots**

**Note symbol**

-L	Low channel location
-R	High channel location



5725~5850MHz

WIFI 802.11a (Band Edge @ 3m)

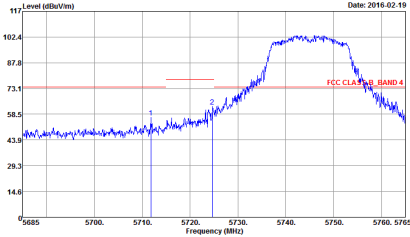
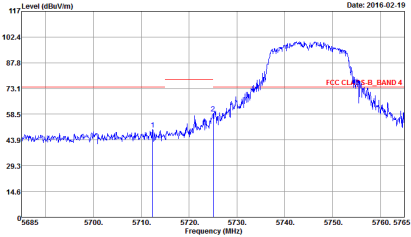
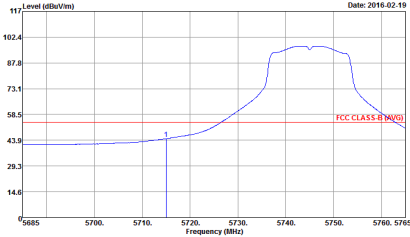
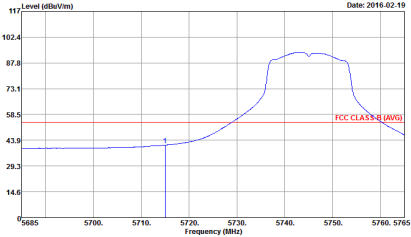
WIFI	5725~5850MHz Band Edge @ 3m	
ANT	802.11a CH149 5745MHz	
1	Horizontal	Vertical
Peak	 <p>Site : 03CH11-HY            Condition : FCC CLASS-B_BAND 4 3m HORN 9120D-HF HORIZONTAL            RBW:1000.000KHz VBW:3000.000KHz SWT:Auto            Detector : Peak            Project : ZD1407-08            Mode : 1</p>	 <p>Site : 03CH11-HY            Condition : FCC CLASS-B_BAND 4 3m HORN 9120D-HF VERTICAL            RBW:1000.000KHz VBW:3000.000KHz SWT:Auto            Detector : Peak            Project : ZD1407-08            Mode : 1</p>
Avg.	 <p>Site : 03CH11-HY            Condition : FCC CLASS-B (AVG) 3m HORN 9120D-HF HORIZONTAL            RBW:1000.000KHz VBW:0.010KHz SWT:Auto            Detector : Peak            Project : ZD1407-08            Mode : 1</p>	 <p>Site : 03CH11-HY            Condition : FCC CLASS-B (AVG) 3m HORN 9120D-HF VERTICAL            RBW:1000.000KHz VBW:0.010KHz SWT:Auto            Detector : Peak            Project : ZD1407-08            Mode : 1</p>

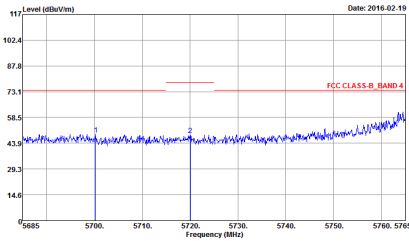
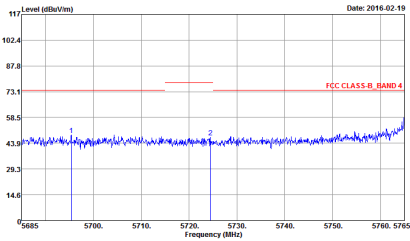
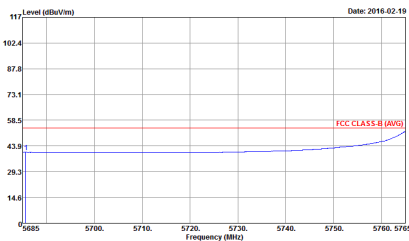
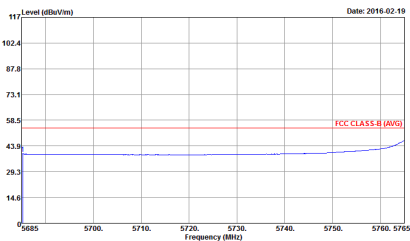

WIFI	5725~5850MHz Band Edge @ 3m	
ANT	802.11a CH157 5785MHz - L	
1	Horizontal	Vertical
Peak	 <p>Date: 2016.02.19</p> <p>Site : 03CH11-HY            Condition : FCC CLASS-B_BAND 4 3m HORN 9120D-HF HORIZONTAL            RBW:1000.000KHz VBW:3000.000KHz SWT:Auto            Detector : Peak            Project : 2D1407-08            Mode : 2</p>	 <p>Date: 2016.02.19</p> <p>Site : 03CH11-HY            Condition : FCC CLASS-B_BAND 4 3m HORN 9120D-HF VERTICAL            RBW:1000.000KHz VBW:3000.000KHz SWT:Auto            Detector : Peak            Project : 2D1407-08            Mode : 2</p>
Avg.	 <p>Date: 2016.02.19</p> <p>Site : 03CH11-HY            Condition : FCC CLASS-B (AVG) 3m HORN 9120D-HF HORIZONTAL            RBW:1000.000KHz VBW:0.010KHz SWT:Auto            Detector : Peak            Project : 2D1407-08            Mode : 2</p>	 <p>Date: 2016.02.19</p> <p>Site : 03CH11-HY            Condition : FCC CLASS-B (AVG) 3m HORN 9120D-HF VERTICAL            RBW:1000.000KHz VBW:0.010KHz SWT:Auto            Detector : Peak            Project : 2D1407-08            Mode : 2</p>

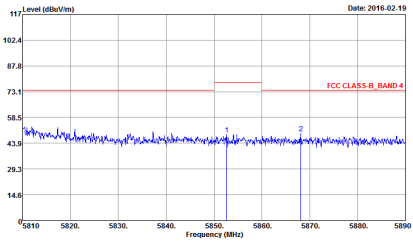
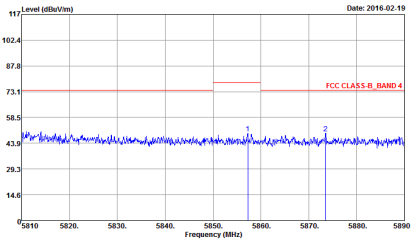
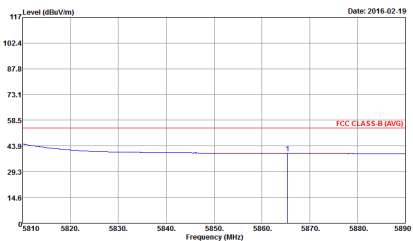
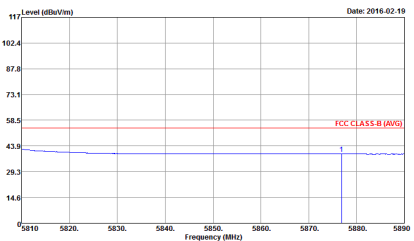

WIFI	5725~5850MHz Band Edge @ 3m	
ANT	802.11a CH157 5785MHz - R	
1	Horizontal	Vertical
Peak	 <p>Site : 03CH11-HY            Condition : FCC CLASS-B_BAND 4 3m HORN 9120D-HF HORIZONTAL            RBW:1000.000KHz VBW:3000.000KHz SWT:Auto            Detector : Peak            Project : 2D1407-08            Mode : 2</p>	 <p>Site : 03CH11-HY            Condition : FCC CLASS-B_BAND 4 3m HORN 9120D-HF VERTICAL            RBW:1000.000KHz VBW:3000.000KHz SWT:Auto            Detector : Peak            Project : 2D1407-08            Mode : 2</p>
Avg.	 <p>Site : 03CH11-HY            Condition : FCC CLASS-B (AVG) 3m HORN 9120D-HF HORIZONTAL            RBW:1000.000KHz VBW:0.010KHz SWT:Auto            Detector : Peak            Project : 2D1407-08            Mode : 2</p>	 <p>Site : 03CH11-HY            Condition : FCC CLASS-B (AVG) 3m HORN 9120D-HF VERTICAL            RBW:1000.000KHz VBW:0.010KHz SWT:Auto            Detector : Peak            Project : 2D1407-08            Mode : 2</p>



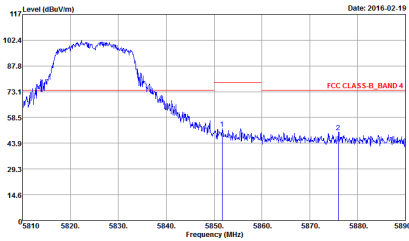
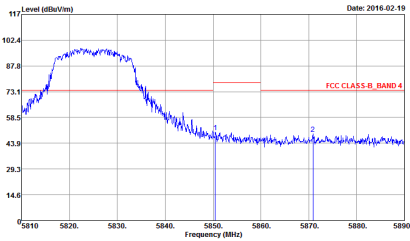
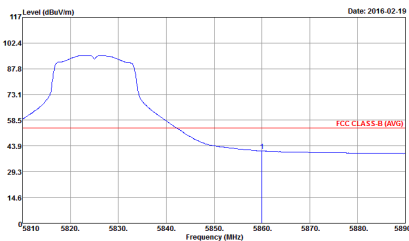
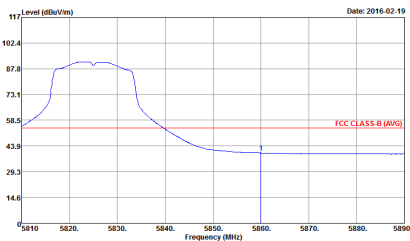

WIFI	5725~5850MHz Band Edge @ 3m	
ANT	802.11a CH165 5825MHz	
1	Horizontal	Vertical
Peak	 <p>Site : 03CH11-HY            Condition : FCC CLASS-B_BAND 4 3m HORN 9120D-HF HORIZONTAL            RBW:1000.000KHz VBW:3000.000KHz SWT:Auto            Detector : Peak            Project : 2D1407-08            Mode : 3</p>	 <p>Site : 03CH11-HY            Condition : FCC CLASS-B_BAND 4 3m HORN 9120D-HF VERTICAL            RBW:1000.000KHz VBW:3000.000KHz SWT:Auto            Detector : Peak            Project : 2D1407-08            Mode : 3</p>
Avg.	 <p>Site : 03CH11-HY            Condition : FCC CLASS-B (AVG) 3m HORN 9120D-HF HORIZONTAL            RBW:1000.000KHz VBW:0.010KHz SWT:Auto            Detector : Peak            Project : 2D1407-08            Mode : 3</p>	 <p>Site : 03CH11-HY            Condition : FCC CLASS-B (AVG) 3m HORN 9120D-HF VERTICAL            RBW:1000.000KHz VBW:0.010KHz SWT:Auto            Detector : Peak            Project : 2D1407-08            Mode : 3</p>



5725~5850MHz

WIFI 802.11n HT20 (Band Edge @ 3m)

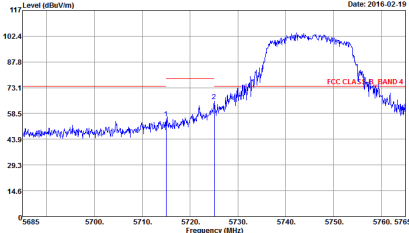
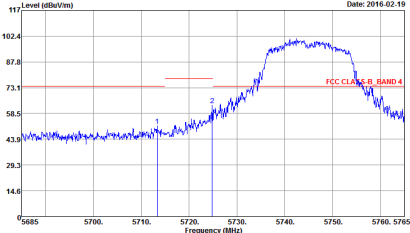
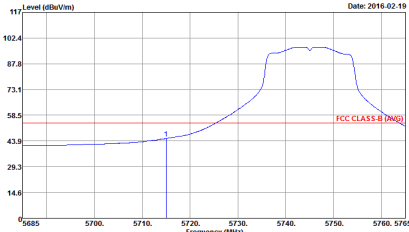
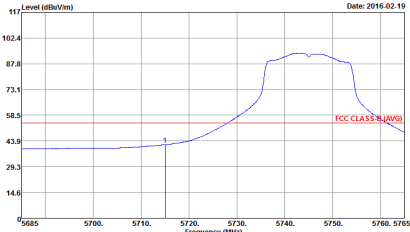
WIFI	5725~5850MHz Band Edge @ 3m	
ANT	802.11n HT20 CH149 5745MHz	
1	Horizontal	Vertical
Peak	 <p>Site : 03CH11-HY            Condition : FCC CLASS-B_BAND 4 3m HORN 9120D-HF HORIZONTAL            Detector : Peak            Project : ZD1407-08            Mode : 4</p>	 <p>Site : 03CH11-HY            Condition : FCC CLASS-B_BAND 4 3m HORN 9120D-HF VERTICAL            Detector : Peak            Project : ZD1407-08            Mode : 4</p>
Avg.	 <p>Site : 03CH11-HY            Condition : FCC CLASS-B (AVG) 3m HORN 9120D-HF HORIZONTAL            Detector : Peak            Project : ZD1407-08            Mode : 4</p>	 <p>Site : 03CH11-HY            Condition : FCC CLASS-B (AVG) 3m HORN 9120D-HF VERTICAL            Detector : Peak            Project : ZD1407-08            Mode : 4</p>

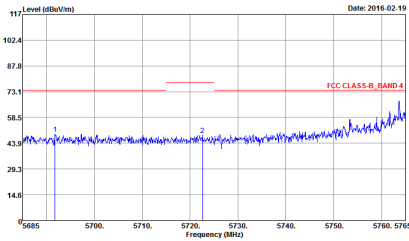
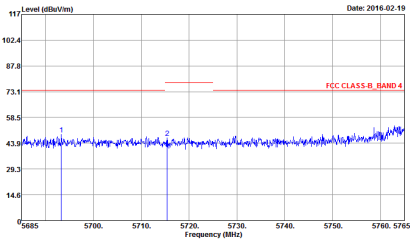
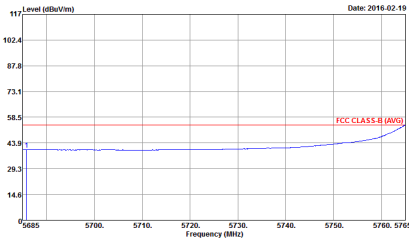
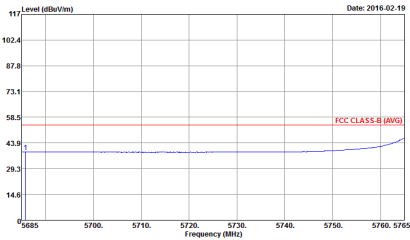

WIFI	5725~5850MHz Band Edge @ 3m	
ANT	802.11n HT20 CH157 5785MHz - L	
1	Horizontal	Vertical
Peak	 <p>Site : 03CH11-HY            Condition : FCC CLASS-B_BAND 4 3m HORN 9120D-HF HORIZONTAL            RBW:1000.000KHz VBW:3000.000KHz SWT:Auto            Detector : Peak            Project : ZD1407-08            Mode : 5</p>	 <p>Site : 03CH11-HY            Condition : FCC CLASS-B_BAND 4 3m HORN 9120D-HF VERTICAL            RBW:1000.000KHz VBW:3000.000KHz SWT:Auto            Detector : Peak            Project : ZD1407-08            Mode : 5</p>
Avg.	 <p>Site : 03CH11-HY            Condition : FCC CLASS-B (AVG) 3m HORN 9120D-HF HORIZONTAL            RBW:1000.000KHz VBW:0.010KHz SWT:Auto            Detector : Peak            Project : ZD1407-08            Mode : 5</p>	 <p>Site : 03CH11-HY            Condition : FCC CLASS-B (AVG) 3m HORN 9120D-HF VERTICAL            RBW:1000.000KHz VBW:0.010KHz SWT:Auto            Detector : Peak            Project : ZD1407-08            Mode : 5</p>

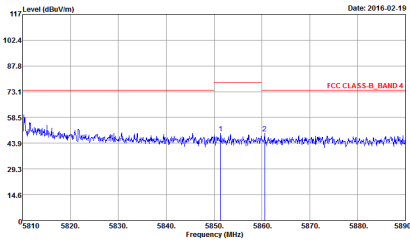
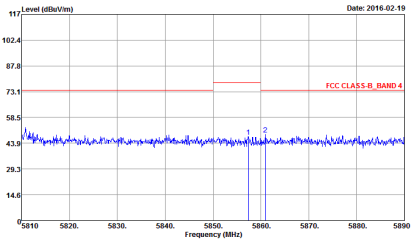
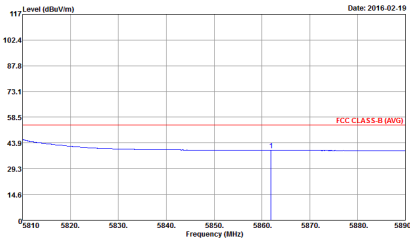
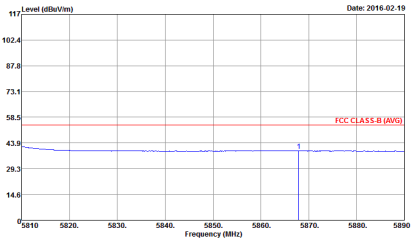

WIFI	5725~5850MHz Band Edge @ 3m	
ANT	802.11n HT20 CH157 5785MHz - R	
1	Horizontal	Vertical
Peak	 <p>Date: 2016.02.19</p> <p>Site : 03CH11-HY            Condition : FCC CLASS-B_BAND 4 3m HORN 9120D-HF HORIZONTAL            : RBW:1000.000KHz VBW:3000.000KHz SWT:Auto            Detector : Peak            Project : ZD1407-08            Mode : 5</p>	 <p>Date: 2016.02.19</p> <p>Site : 03CH11-HY            Condition : FCC CLASS-B_BAND 4 3m HORN 9120D-HF VERTICAL            : RBW:1000.000KHz VBW:3000.000KHz SWT:Auto            Detector : Peak            Project : ZD1407-08            Mode : 5</p>
Avg.	 <p>Date: 2016.02.19</p> <p>Site : 03CH11-HY            Condition : FCC CLASS-B (AVG) 3m HORN 9120D-HF HORIZONTAL            : RBW:1000.000KHz VBW:0.010KHz SWT:Auto            Detector : Peak            Project : ZD1407-08            Mode : 5</p>	 <p>Date: 2016.02.19</p> <p>Site : 03CH11-HY            Condition : FCC CLASS-B (AVG) 3m HORN 9120D-HF VERTICAL            : RBW:1000.000KHz VBW:0.010KHz SWT:Auto            Detector : Peak            Project : ZD1407-08            Mode : 5</p>

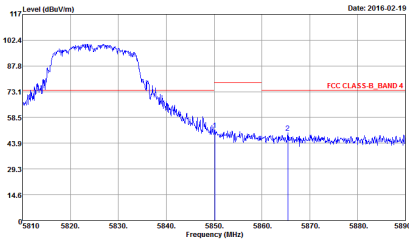
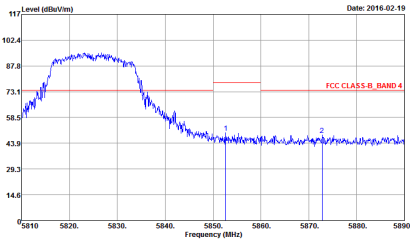
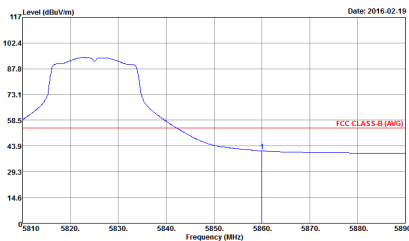
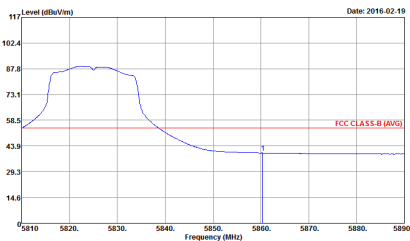

WIFI	5725~5850MHz Band Edge @ 3m	
ANT	802.11n HT20 CH165 5825MHz	
1	Horizontal	Vertical
Peak	 <p>Site : 03CH11-HY            Condition : FCC CLASS-B_BAND 4 3m HORN 9120D-HF HORIZONTAL            RBW:1000.000KHz VBW:3000.000KHz SWT:Auto            Detector : Peak            Project : ZD1407-08            Mode : 6</p>	 <p>Site : 03CH11-HY            Condition : FCC CLASS-B_BAND 4 3m HORN 9120D-HF VERTICAL            RBW:1000.000KHz VBW:3000.000KHz SWT:Auto            Detector : Peak            Project : ZD1407-08            Mode : 6</p>
Avg.	 <p>Site : 03CH11-HY            Condition : FCC CLASS-B (AVG) 3m HORN 9120D-HF HORIZONTAL            RBW:1000.000KHz VBW:0.010KHz SWT:Auto            Detector : Peak            Project : ZD1407-08            Mode : 6</p>	 <p>Site : 03CH11-HY            Condition : FCC CLASS-B (AVG) 3m HORN 9120D-HF VERTICAL            RBW:1000.000KHz VBW:0.010KHz SWT:Auto            Detector : Peak            Project : ZD1407-08            Mode : 6</p>



5725~5850MHz

WIFI 802.11a (Harmonic @ 3m)

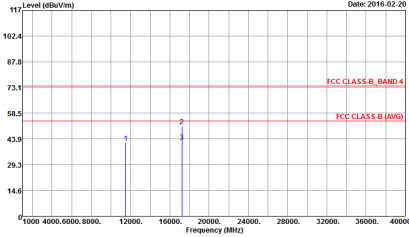
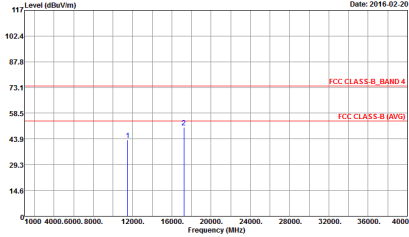
WIFI	5725~5850MHz Harmonic @ 3m	
ANT	802.11a CH149 5745MHz	
1	Horizontal	Vertical
<p><b>Peak</b></p> <p><b>Avg.</b></p>	 <p>Site : 03CH11-11Y            Condition : FCC CLASS-B_BAND 4 3m 9170 SHF HORM_150809 HORIZONTAL            Detector : Peak            Project : 2D1407-08            Mode : 1</p>	 <p>Site : 03CH11-11Y            Condition : FCC CLASS-B_BAND 4 3m 9170 SHF HORM_150809 VERTICAL            Detector : Peak            Project : 2D1407-08            Mode : 1</p>

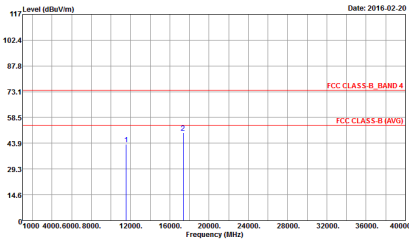
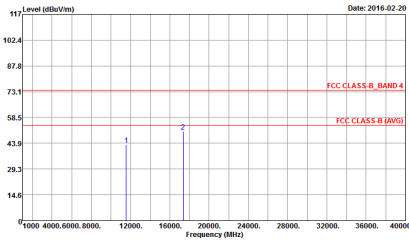

WIFI	5725~5850MHz Harmonic @ 3m	
ANT	802.11a CH157 5785MHz	
1	Horizontal	Vertical
<p><b>Peak</b></p> <p><b>Avg.</b></p>	 <p>Site : 03CH11-HY            Condition : FCC CLASS-B_BAND 4 3m 9170 SHF HORM_150809 HORIZONTAL            Detector : Peak            Project : ZD1407-08            Mode : 2</p>	 <p>Site : 03CH11-HY            Condition : FCC CLASS-B_BAND 4 3m 9170 SHF HORM_150809 VERTICAL            Detector : Peak            Project : ZD1407-08            Mode : 2</p>

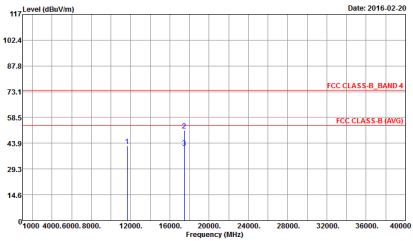
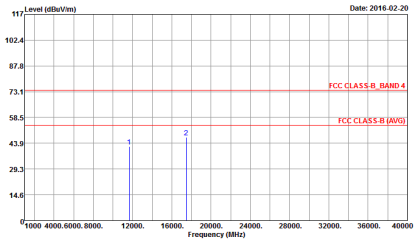

WIFI	5725~5850MHz Harmonic @ 3m	
ANT	802.11a CH165 5825MHz	
1	Horizontal	Vertical
<p><b>Peak</b></p> <p><b>Avg.</b></p>	 <p>Site : 03CH11-HY            Condition : FCC CLASS-B_BAND 4 3m 9170 SHF HORM_150809 HORIZONTAL            Detector : Peak            Project : ZD1407-08            Mode : 3</p>	 <p>Site : 03CH11-HY            Condition : FCC CLASS-B_BAND 4 3m 9170 SHF HORM_150809 VERTICAL            Detector : Peak            Project : ZD1407-08            Mode : 3</p>





5725~5850MHz

WIFI 802.11n HT20 (Harmonic @ 3m)

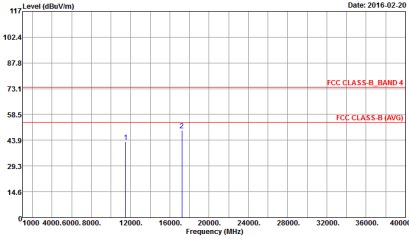
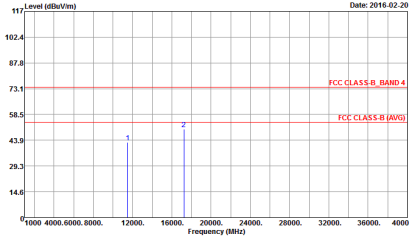
WIFI	5725~5850MHz Harmonic @ 3m	
ANT	802.11n HT20 CH149 5745MHz	
1	Horizontal	Vertical
<p><b>Peak</b></p> <p><b>Avg.</b></p>	 <p>Site : 03CH11-HY            Condition : FCC CLASS-B_BAND 4 3m 9170 SHF HORM_150809 HORIZONTAL            Detector : Peak            Project : ZD1407-08            Mode : 4</p>	 <p>Site : 03CH11-HY            Condition : FCC CLASS-B_BAND 4 3m 9170 SHF HORM_150809 VERTICAL            Detector : Peak            Project : ZD1407-08            Mode : 4</p>

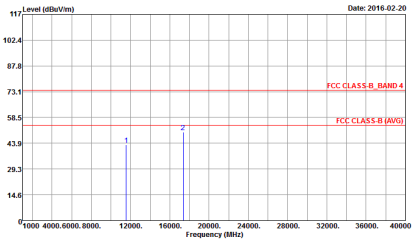
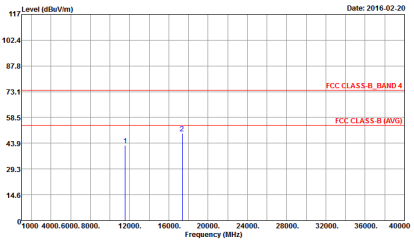

WIFI	5725~5850MHz Harmonic @ 3m	
ANT	802.11n HT20 CH157 5785MHz	
1	Horizontal	Vertical
<p><b>Peak</b></p> <p><b>Avg.</b></p>	 <p>Site : 03CH11-HY            Condition : FCC CLASS-B_BAND 4 3m 9170 SHF HORM_150809 HORIZONTAL            Detector : Peak            Project : ZD1407-08            Mode : 5</p>	 <p>Site : 03CH11-HY            Condition : FCC CLASS-B_BAND 4 3m 9170 SHF HORM_150809 VERTICAL            Detector : Peak            Project : ZD1407-08            Mode : 5</p>

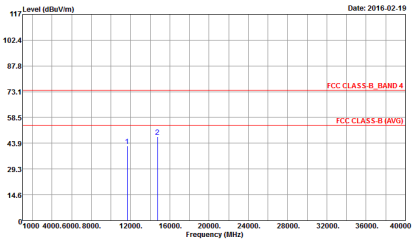
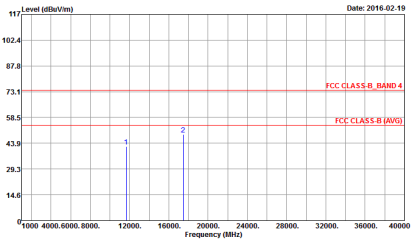

WIFI	5725~5850MHz Harmonic @ 3m	
ANT	802.11n HT20 CH165 5825MHz	
1	Horizontal	Vertical
<p><b>Peak</b></p> <p><b>Avg.</b></p>	 <p>Site : 03CH11-HY            Condition : FCC CLASS-B_BAND 4 3m 9170 SHF HORM_150809 HORIZONTAL            Detector : Peak            Project : ZD1407-08            Mode : -6</p>	 <p>Site : 03CH11-HY            Condition : FCC CLASS-B_BAND 4 3m 9170 SHF HORM_150809 VERTICAL            Detector : Peak            Project : ZD1407-08            Mode : -6</p>



Emission below 1GHz

5GHz WIFI 802.11n HT20 (LF)

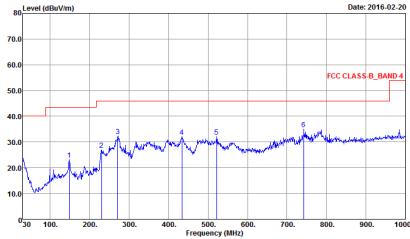
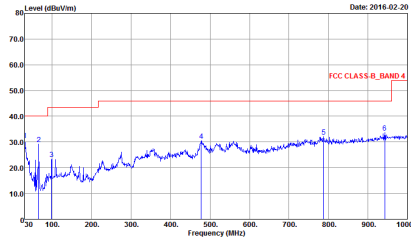
WIFI	5GHz 5725~5850MHz	
ANT	802.11n HT20 LF	
1	Horizontal	Vertical
<p>QP / Peak</p>	 <p>Site : 03CH11-11Y Condition : FCC CLASS-B_BAND 4 3m BI-LOG 6111D-LF_ETC HORIZONTAL Detector : Peak Project : ZD1407-08 Mode : 7</p>	 <p>Site : 03CH11-11Y Condition : FCC CLASS-B_BAND 4 3m BI-LOG 6111D-LF_ETC VERTICAL Detector : Peak Project : ZD1407-08 Mode : 7</p>