



FCC TEST REPORT

REPORT NO.: RF980507H07

MODEL NO.: CA1060

RECEIVED: May 07, 2009

TESTED: May 08 to 22, 2009

ISSUED: June 08, 2009

APPLICANT: Motorola Inc.

ADDRESS: One Motorola Plaza Holtsville, NY 11742

ISSUED BY: Bureau Veritas Consumer Products Services
(H.K.) Ltd., Taoyuan Branch

LAB ADDRESS: No. 81-1, Lu Liao Keng, 9th Ling, Wu Lung Tsuen,
Chiung Lin Hsiang, Hsin Chu Hsien 307, Taiwan

This test report consists of 77 pages in total. It may be duplicated completely for legal use with the approval of the applicant. It should not be reproduced except in full, without the written approval of our laboratory. The client should not use it to claim product endorsement by TAF or any government agencies. The test results in the report only apply to the tested sample.



Table of Contents

1.	CERTIFICATION.....	4
2.	SUMMARY OF TEST RESULTS	5
2.1	MEASUREMENT UNCERTAINTY.....	6
3.	GENERAL INFORMATION.....	7
3.1	GENERAL DESCRIPTION OF EUT.....	7
3.2	DESCRIPTION OF TEST MODES	9
3.2.1	TEST MODE APPLICABILITY AND TESTED CHANNEL DETAIL:.....	10
3.3	GENERAL DESCRIPTION OF APPLIED STANDARDS	12
3.4	DESCRIPTION OF SUPPORT UNITS	13
3.5	CONFIGURATION OF SYSTEM UNDER TEST.....	14
4.	TEST TYPES AND RESULTS	15
4.1	RADIATED EMISSION MEASUREMENT	15
4.1.1	LIMITS OF RADIATED EMISSION MEASUREMENT	15
4.1.2	TEST INSTRUMENTS	16
4.1.3	TEST PROCEDURES.....	18
4.1.4	DEVIATION FROM TEST STANDARD	19
4.1.5	TEST SETUP.....	19
4.1.6	EUT OPERATING CONDITIONS.....	19
4.1.7	TEST RESULTS.....	20
4.2	6dB BANDWIDTH MEASUREMENT	54
4.2.1	LIMITS OF 6DB BANDWIDTH MEASUREMENT	54
4.2.2	TEST INSTRUMENTS	54
4.2.3	TEST PROCEDURE	55
4.2.4	DEVIATION FROM TEST STANDARD	55
4.2.5	TEST SETUP.....	55
4.2.6	EUT OPERATING CONDITIONS.....	55
4.2.7	TEST RESULTS.....	56
4.3	MAXIMUM PEAK OUTPUT POWER.....	60
4.3.1	LIMITS OF MAXIMUM PEAK OUTPUT POWER MEASUREMENT.....	60
4.3.2	INSTRUMENTS	60
4.3.3	TEST PROCEDURES.....	61
4.3.4	DEVIATION FROM TEST STANDARD	61
4.3.5	TEST SETUP.....	61
4.3.6	EUT OPERATING CONDITIONS.....	61
4.3.7	TEST RESULTS.....	62



A D T

4.4	POWER SPECTRAL DENSITY MEASUREMENT	63
4.4.1	LIMITS OF POWER SPECTRAL DENSITY MEASUREMENT.....	63
4.4.2	TEST INSTRUMENTS	63
4.4.3	TEST PROCEDURE	64
4.4.4	DEVIATION FROM TEST STANDARD	64
4.4.5	TEST SETUP.....	64
4.4.6	EUT OPERATING CONDITION.....	64
4.4.7	TEST RESULTS.....	65
4.5	CONDUCTED OUT-BAND EMISSION MEASUREMENT.....	69
4.5.1	LIMITS OF CONDUCTED OUT-BAND EMISSION MEASUREMENT.....	69
4.5.2	TEST INSTRUMENTS	69
4.5.3	TEST PROCEDURE	69
4.5.4	DEVIATION FROM TEST STANDARD	70
4.5.5	EUT OPERATING CONDITION.....	70
4.5.6	TEST RESULTS.....	70
4.6	ANTENNA REQUIREMENT	75
4.6.1	STANDARD APPLICABLE	75
4.6.2	ANTENNA CONNECTED CONSTRUCTION	75
5.	INFORMATION ON THE TESTING LABORATORIES.....	76
6.	APPENDIX A - MODIFICATIONS RECORDERS FOR ENGINEERING CHANGES TO THE EUT BY THE LAB.....	77



A D T

1. CERTIFICATION

PRODUCT: WiFi Voice Communication Appliance
BRAND NAME: MOTOROLA
MODEL NO.: CA1060
TEST SAMPLE: MASS-PRODUCTION
TESTED: May 08 to 22, 2009
APPLICANT: Motorola Inc.
STANDARDS: FCC Part 15, Subpart C (Section 15.247),
ANSI C63.4-2003

The above equipment (Model: CA1060) has been tested by **Bureau Veritas Consumer Products Services (H.K.) Ltd., Taoyuan Branch**, and found compliance with the requirement of the above standards. The test record, data evaluation & Equipment Under Test (EUT) configurations represented herein are true and accurate accounts of the measurements of the sample's EMC characteristics under the conditions specified in this report.

PREPARED BY : Carol Liao , **DATE:** June 08, 2009
(Carol Liao, Specialist)

TECHNICAL ACCEPTANCE : Hank Chung , **DATE:** June 08, 2009
Responsible for RF (Hank Chung, Deputy Manager)

APPROVED BY : May Chen , **DATE:** June 08, 2009
(May Chen, Deputy Manager)



2. SUMMARY OF TEST RESULTS

The EUT has been tested according to the following specifications:

APPLIED STANDARD: FCC Part 15, Subpart C (Section 15.247)			
Standard Section	Test Type and Limit	Result	Remark
15.207	AC Power Conducted Emission	NA	Not Applicable
15.247(a)(2)	Spectrum Bandwidth of a Direct Sequence Spread Spectrum System Limit: min. 500kHz	PASS	Meet the requirement of limit.
15.247(b)	Maximum Peak Output Power Limit: max. 30dBm	PASS	Meet the requirement of limit.
15.247(d)	Radiated Emissions Limit: Table 15.209	PASS	Meet the requirement of limit. Minimum passing margin is -4.21dB at 2390.00MHz
15.247(e)	Power Spectral Density Limit: max. 8dBm	PASS	Meet the requirement of limit.
15.247(d)	Band Edge Measurement Limit: 20dB less than the peak value of fundamental frequency	PASS	Meet the requirement of limit.



2.1 MEASUREMENT UNCERTAINTY

Where relevant, the following measurement uncertainty levels have been estimated for tests performed on the EUT as specified in CISPR 16-4-2:

This uncertainty represents an expanded uncertainty expressed at approximately the 95% confidence level using a coverage factor of $k=2$.

Below 1GHz:

Measurement	Value
Radiated emissions (30MHz-1GHz)	3.94 dB
Radiated emissions (1GHz -18GHz)	2.49 dB
Radiated emissions (18GHz -40GHz)	2.70 dB

Above 1GHz:

Measurement	Value
Radiated emissions (30MHz-1GHz)	3.83 dB
Radiated emissions (1GHz -18GHz)	2.44 dB
Radiated emissions (18GHz -40GHz)	2.67 dB



3. GENERAL INFORMATION

3.1 GENERAL DESCRIPTION OF EUT

PRODUCT	WiFi Voice Communication Appliance
MODEL NO.	CA1060
FCC ID	UZ7CA1060
POWER SUPPLY	DC 3.9~4.2V from Battery
MODULATION TYPE	CCK, DQPSK, DBPSK for DSSS 64QAM, 16QAM, QPSK, BPSK for OFDM
MODULATION TECHNOLOGY	DSSS, OFDM
TRANSFER RATE	802.11b: 11 / 5.5 / 2 / 1Mbps 802.11g: 54 / 48 / 36 / 24 / 18 / 12 / 9 / 6Mbps
OPERATING FREQUENCY	2412 ~ 2462MHz
MAXIMUM OUTPUT POWER	802.11b: 116.681mW 802.11g: 249.459mW
ANTENNA TYPE	PIFA antenna with -3.5 dBi antenna gain
DATA CABLE	NA
I/O PORTS	Female Socket Port x 1
ACCESSORY	Headset (Brand: AAPC, Model: AEP-KT02D-02)

NOTE:

1. The EUT was pre-tested in chamber under the following modes:

Test Mode	Description
Mode A	X-Y plane
Mode B	Z-X plane
Mode C	Z-Y plane

For radiated test mode, the worse case was found in **Mode C**. Therefore only the test data of the mode was recorded in this report.

2. The EUT was pre-tested in chamber under the following modes:

Test Mode	Description
Mode 1	EUT only
Mode 2	EUT with headset

For radiated test (Above 1 GHz), the worse case was found in **Mode 2**. Therefore only the test data of the mode was recorded in this report.



A D T

3. The EUT, operates in the 2.4GHz frequency range, lets you connect IEEE 802.11g or IEEE 802.11b devices to the network. With its high-speed data transmissions of up to 54Mbps.
4. The above EUT information was declared by the manufacturer and for more detailed features description, please refer to the manufacturer's specifications or User's Manual.



3.2 DESCRIPTION OF TEST MODES

Eleven channels are provided for 802.11b, 802.11g:

CHANNEL	FREQUENCY	CHANNEL	FREQUENCY
1	2412MHz	7	2442MHz
2	2417MHz	8	2447MHz
3	2422MHz	9	2452MHz
4	2427MHz	10	2457MHz
5	2432MHz	11	2462MHz
6	2437MHz		



A D T

3.2.1 TEST MODE APPLICABILITY AND TESTED CHANNEL DETAIL:

EUT CONFIGURE MODE	APPLICABLE TO				DESCRIPTION
	PLC	RE < 1G	RE ≥ 1G	APCM	
MODE 1	NA	√	-	-	EUT only
MODE 2	NA	√	√	√	EUT with headset

Where **PLC**: Power Line Conducted Emission **RE < 1G**: Radiated Emission below 1GHz
RE ≥ 1G: Radiated Emission above 1GHz **APCM**: Antenna Port Conducted Measurement

RADIATED EMISSION TEST (BELOW 1 GHz):

- Pre-Scan has been conducted to determine the worst-case mode from all possible combinations between available modulations, data rates and antenna ports (if EUT with antenna diversity architecture).
- Following channel(s) was (were) selected for the final test as listed below.

MODE	AVAILABLE CHANNEL	TESTED CHANNEL	MODULATION TECHNOLOGY	MODULATION TYPE	DATA RATE (Mbps)	EUT CONFIGURE MODE
802.11b	1 to 11	1	DSSS	DBPSK	1	MODE 1
802.11b	1 to 11	1	DSSS	DBPSK	1	MODE 2

RADIATED EMISSION TEST (ABOVE 1 GHz):

- Pre-Scan has been conducted to determine the worst-case mode from all possible combinations between available modulations, data rates and antenna ports (if EUT with antenna diversity architecture).
- Following channel(s) was (were) selected for the final test as listed below.

MODE	AVAILABLE CHANNEL	TESTED CHANNEL	MODULATION TECHNOLOGY	MODULATION TYPE	DATA RATE (Mbps)	EUT CONFIGURE MODE
802.11b	1 to 11	1, 2, 3, 6, 10, 11	DSSS	DBPSK	1	MODE 2
802.11g	1 to 11	1, 2, 3, 6, 10, 11	OFDM	BPSK	6	MODE 2

BANDEDGE MEASUREMENT:

- Pre-Scan has been conducted to determine the worst-case mode from all possible combinations between available modulations, data rates and antenna ports (if EUT with antenna diversity architecture).
- Following channel(s) was (were) selected for the final test as listed below.

MODE	AVAILABLE CHANNEL	TESTED CHANNEL	MODULATION TECHNOLOGY	MODULATION TYPE	DATA RATE (Mbps)	EUT CONFIGURE MODE
802.11b	1 to 11	1, 2, 3, 6, 10, 11	DSSS	DBPSK	1	MODE 2
802.11g	1 to 11	1, 2, 3, 6, 10, 11	OFDM	BPSK	6	MODE 2

ANTENNA PORT CONDUCTED MEASUREMENT:

- Pre-Scan has been conducted to determine the worst-case mode from all possible combinations between available modulations, data rates and antenna ports (if EUT with antenna diversity architecture).
- Following channel(s) was (were) selected for the final test as listed below.

MODE	AVAILABLE CHANNEL	TESTED CHANNEL	MODULATION TECHNOLOGY	MODULATION TYPE	DATA RATE (Mbps)	EUT CONFIGURE MODE
802.11b	1 to 11	1, 6, 11	DSSS	DBPSK	1	MODE 2
802.11g	1 to 11	1, 6, 11	OFDM	BPSK	6	MODE 2

3.3 GENERAL DESCRIPTION OF APPLIED STANDARDS

The EUT is a RF product. According to the specifications of the manufacturer, it must comply with the requirements of the following standards:

FCC Part 15, Subpart C. (15.247)

ANSI C63.4-2003

All test items have been performed and recorded as per the above standards.

NOTE: The EUT is also considered as a kind of computer peripheral, because the connection to computer is necessary for typical use. It has been verified to comply with the requirements of FCC Part 15, Subpart B, Class B (DoC). The test report has been issued separately.



A D T

3.4 DESCRIPTION OF SUPPORT UNITS

The EUT has been tested as an independent unit together with other necessary accessories or support units. The following support units or accessories were used to form a representative test configuration during the tests.

NO.	PRODUCT	BRAND	MODEL NO.	SERIAL NO.	FCC ID
1	Headset	AAPC	AEP-KT02D-02	NA	NA

NO.	SIGNAL CABLE DESCRIPTION OF THE ABOVE SUPPORT UNITS
1	56 cm Headset cable with male plug

NOTE: All power cords of the above support units are non shielded (1.8m).

3.5 CONFIGURATION OF SYSTEM UNDER TEST

For Radiated test (EUT only):

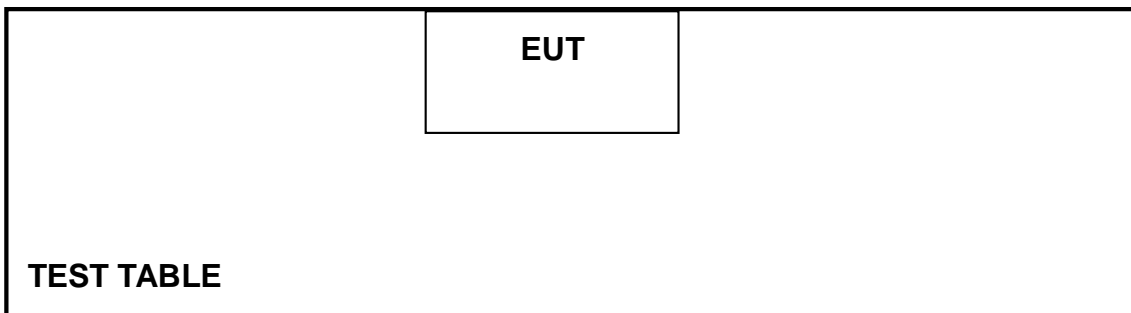

For Radiated test (EUT with headset):

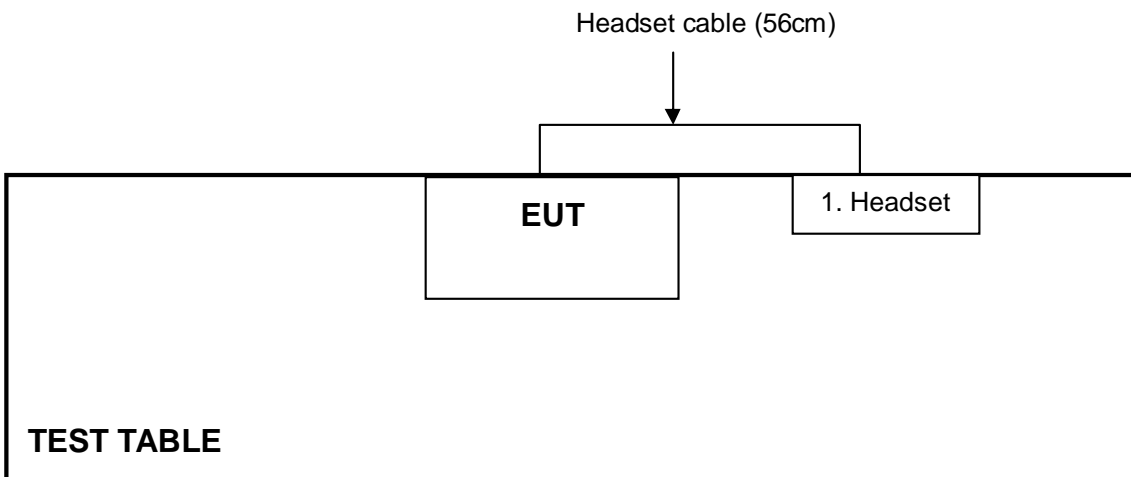

4. TEST TYPES AND RESULTS

4.1 RADIATED EMISSION MEASUREMENT

4.1.1 LIMITS OF RADIATED EMISSION MEASUREMENT

Emissions radiated outside of the specified bands, shall be according to the general radiated limits in 15.209 as following:

Frequencies (MHz)	Field strength (microvolts/meter)	Measurement distance (meters)
0.009-0.490	2400/F(kHz)	300
0.490-1.705	24000/F(kHz)	30
1.705-30.0	30	30
30-88	100	3
88-216	150	3
216-960	200	3
Above 960	500	3

NOTE:

1. The lower limit shall apply at the transition frequencies.
2. Emission level (dBuV/m) = 20 log Emission level (uV/m).
3. As shown in 15.35(b), for frequencies above 1000MHz, the field strength limits are based on average detector, however, the peak field strength of any emission shall not exceed the maximum permitted average limits, specified above by more than 20dB under any condition of modulation.

4.1.2 TEST INSTRUMENTS

Below 1GHz:

DESCRIPTION & MANUFACTURER	MODEL NO.	SERIAL NO.	CALIBRATED DATE	CALIBRATED UNTIL
ROHDE & SCHWARZ Spectrum Analyzer	FSP40	100036	Dec. 9, 2008	Dec. 08, 2009
HP Pre_Amplifier	8449B	3008A01923	Nov. 10, 2008	Nov. 09, 2009
ROHDE & SCHWARZ Test Receiver	ESCS30	847124/029	Sep. 9, 2008	Sep. 08, 2009
SCHWARZBECK TRILOG Broadband Antenna	VULB 9168	138	April 29, 2009	April 28, 2010
Schwarzbeck Horn_Antenna	BBHA9120	D124	Dec. 09, 2008	Dec. 08, 2009
Schwarzbeck Horn_Antenna	BBHA 9170	BBHA9170153	Jan. 22, 2009	Jan. 21, 2010
R&S Loop Antenna	HFH2-Z2	100070	Jan. 14, 2008	Jan. 13, 2010
RF Switches	EMH-011	08009	Oct. 07, 2008	Oct. 06, 2009
RF CABLE (Chaintek)	Sucoflex 106	28077	Aug. 15, 2008	Aug. 14, 2009
RF Cable	8DFB	STCCAB-30M-1GHz	Oct. 07, 2008	Oct. 06, 2009
Software	ADT_Radiated_V7.6.15.9.2	NA	NA	NA
CT Antenna Tower & Turn Table	NA	NA	NA	NA

Note: 1. The calibration interval of the above test instruments is 12 months and the calibrations are traceable to NML/ROC and NIST/USA.

2. The horn antenna, HP preamplifier (model: 8449B) and Spectrum Analyzer (model: FSP40) are used only for the measurement of emission frequency above 1GHz if tested.
3. The test was performed in Open Site No. C.
4. The FCC Site Registration No. is 656396.
5. The VCCI Site Registration No. is R-1626.
6. The CANADA Site Registration No. is IC 7450G-3.



A D T

Above 1GHz:

DESCRIPTION & MANUFACTURER	MODEL NO.	SERIAL NO.	CALIBRATED DATE	CALIBRATED UNTIL
ADVANTEST Spectrum Analyzer	U3751	17010023	July. 31, 2008	July. 30, 2009
ADVANTEST Spectrum Analyzer	U3772	160100280	July 26, 2008	July 25, 2009
HP Pre_Amplifier	8449B	3008A01922	Sep. 25, 2008	Sep. 24, 2009
ROHDE & SCHWARZ Test Receiver	ESVS 30	841977/002	Nov. 03, 2008	Nov. 02, 2009
SCHAFFNER(CHASE) Broadband Antenna	CBL6112B	2798	April 29, 2009	April 28, 2010
Schwarzbeck Horn_Antenna	BBHA9120-D1	D123	Sep. 30, 2008	Sep. 29, 2009
Schwarzbeck Horn_Antenna	BBHA 9170	BBHA9170153	Jan. 23, 2009	Jan. 22, 2010
RF Switches	MP59B	6100175593	Sep. 02, 2008	Sep. 01, 2009
RF Cable	8DFB	STBCAB-30M-1GHz	Sep. 02, 2008	Sep. 01, 2009
Software	ADT_Radiated_V7.6.15.9.2	NA	NA	NA
CT Antenna Tower & Turn Table	NA	NA	NA	NA
CORCOM AC Filter	MRI2030	024/019	NA	NA

Note: 1. The calibration interval of the above test instruments is 12 months and the calibrations are traceable to NML/ROC and NIST/USA.

2. The horn antenna, HP preamplifier (model: 8449B) and Spectrum Analyzer (model: U3772) are used only for the measurement of emission frequency above 1GHz if tested.
3. The test was performed in Open Site No. B.
4. The VCCI Site Registration No. is R-847.
5. The FCC Site Registration No. is 92753.
6. The CANADA Site Registration No. is IC 7450G-2.

4.1.3 TEST PROCEDURES

- a. The EUT was placed on the top of a rotating table 0.8 meters above the ground at a 10 meter open area test site. The table was rotated 360 degrees to determine the position of the highest radiation.
- b. The EUT was set 3 meters away from the interference-receiving antenna, which was mounted on the top of a variable-height antenna tower.
- c. The antenna is a broadband antenna, and its height is varied from one meter to four meters above the ground to determine the maximum value of the field strength. Both horizontal and vertical polarizations of the antenna are set to make the measurement.
- d. For each suspected emission, the EUT was arranged to its worst case and then the antenna was tuned to heights from 1 meter to 4 meters and the rotatable table was turned from 0 degrees to 360 degrees to find the maximum reading.
- e. The test-receiver system was set to Peak Detect Function and Specified Bandwidth with Maximum Hold Mode.
- f. If the emission level of the EUT in peak mode was 10 dB lower than the limit specified, then testing could be stopped and the peak values of the EUT would be reported. Otherwise the emissions that did not have 10 dB margin would be re-tested one by one using peak, quasi-peak or average method as specified and then reported in a data sheet.

NOTE:

1. The resolution bandwidth and video bandwidth of test receiver/spectrum analyzer is 120kHz for Quasi-peak detection at frequency below 1GHz.
2. The resolution bandwidth is 1MHz and video bandwidth of test receiver/spectrum analyzer is 3MHz for Peak detection at frequency above 1GHz.
3. The resolution bandwidth of test receiver/spectrum analyzer is 1 MHz and the video bandwidth is 10 Hz for Average detection (AV) at frequency above 1GHz.

4.1.4 DEVIATION FROM TEST STANDARD

No deviation

4.1.5 TEST SETUP

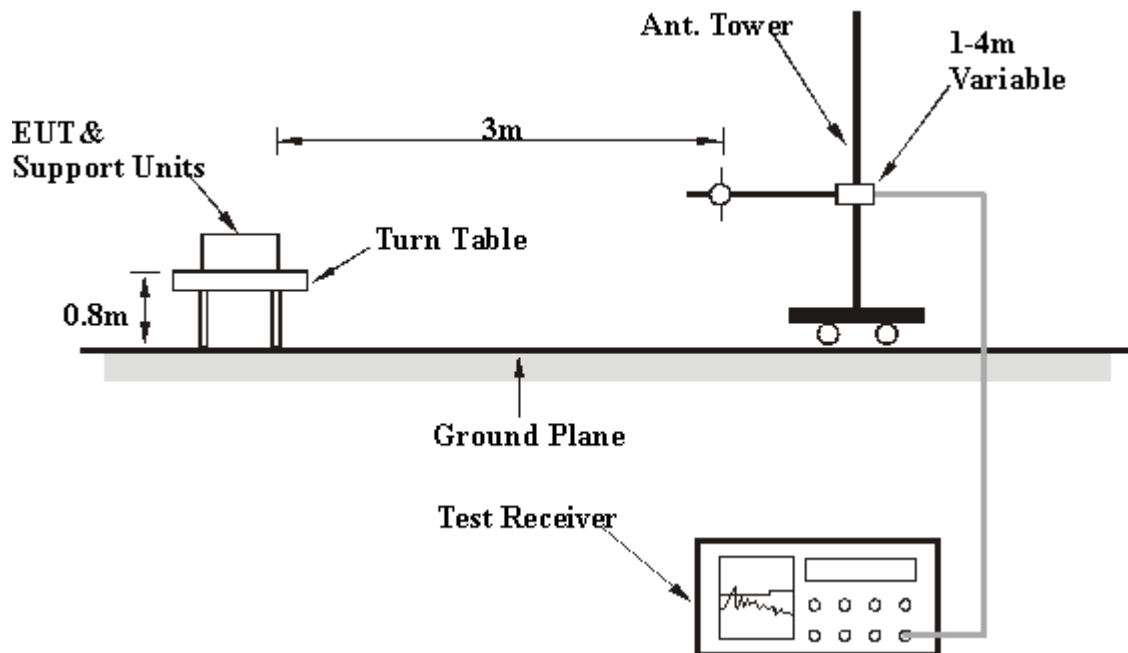

For the actual test configuration, please refer to the related item – Photographs of the Test Configuration.

4.1.6 EUT OPERATING CONDITIONS

For EUT only:

1. Set the EUT under transmission/ receiver condition continuously at specific channel frequency.

For EUT with headset:

1. Set the EUT under transmission/ receiver condition continuously at specific channel frequency.
2. EUT sound comes out from the support unit 1 (Headset).



A D T

4.1.7 TEST RESULTS

BELOW 1GHz WORST-CASE DATA : 802.11b DSSS MODULATION

EUT TEST CONDITION		MEASUREMENT DETAIL	
CHANNEL	Channel 1	FREQUENCY RANGE	Below 1000MHz
INPUT POWER	DC 3.9~4.2V from Battery	DETECTOR FUNCTION	Quasi-Peak
ENVIRONMENTAL CONDITIONS	31deg. C, 59%RH 965hPa	TESTED BY	Eric Lee
TEST MODE	Mode 1		

ANTENNA POLARITY & TEST DISTANCE: HORIZONTAL AT 3 M								
NO.	FREQ. (MHz)	EMISSION LEVEL (dBuV/m)	LIMIT (dBuV/m)	MARGIN (dB)	ANTENNA HEIGHT (m)	TABLE ANGLE (Degree)	RAW VALUE (dBuV)	CORRECTION FACTOR (dB/m)
1	127.12	26.81 QP	43.50	-16.69	1.25 H	47	13.53	13.28
2	136.42	27.12 QP	43.50	-16.38	1.11 H	96	12.88	14.24
3	144.68	27.98 QP	43.50	-15.52	1.02 H	247	12.81	15.17
4	156.81	25.30 QP	43.50	-18.20	1.63 H	203	9.79	15.51
5	200.00	24.12 QP	43.50	-19.38	1.42 H	236	11.73	12.39
6	600.00	25.10 QP	46.00	-20.90	1.82 H	326	0.06	25.04
ANTENNA POLARITY & TEST DISTANCE: VERTICAL AT 3 M								
NO.	FREQ. (MHz)	EMISSION LEVEL (dBuV/m)	LIMIT (dBuV/m)	MARGIN (dB)	ANTENNA HEIGHT (m)	TABLE ANGLE (Degree)	RAW VALUE (dBuV)	CORRECTION FACTOR (dB/m)
1	121.92	27.21 QP	43.50	-16.29	1.56 V	324	14.46	12.75
2	126.41	26.31 QP	43.50	-17.19	1.02 V	192	13.10	13.21
3	135.42	23.10 QP	43.50	-20.40	1.69 V	296	8.96	14.14
4	199.98	28.25 QP	43.50	-15.25	1.46 V	231	15.86	12.39
5	260.01	28.20 QP	46.00	-17.80	1.01 V	2	13.47	14.73
6	849.99	26.30 QP	46.00	-19.70	1.65 V	62	-2.49	28.79

- REMARKS:**
1. Emission level (dBuV/m) = Raw Value (dBuV) + Correction Factor (dB/m).
 2. Correction Factor (dB/m) = Antenna Factor (dB/m) + Cable Factor (dB).
 3. The other emission levels were very low against the limit.
 4. Margin value = Emission level – Limit value.



A D T

EUT TEST CONDITION		MEASUREMENT DETAIL	
CHANNEL	Channel 1	FREQUENCY RANGE	Below 1000MHz
INPUT POWER	DC 3.9~4.2V from Battery	DETECTOR FUNCTION	Quasi-Peak
ENVIRONMENTAL CONDITIONS	31deg. C, 59%RH 965hPa	TESTED BY	Eric Lee
TEST MODE	Mode 2		

ANTENNA POLARITY & TEST DISTANCE: HORIZONTAL AT 3 M

NO.	FREQ. (MHz)	EMISSION LEVEL (dBuV/m)	LIMIT (dBuV/m)	MARGIN (dB)	ANTENNA HEIGHT (m)	TABLE ANGLE (Degree)	RAW VALUE (dBuV)	CORRECTION FACTOR (dB/m)
1	127.10	26.10 QP	43.50	-17.40	1.24 H	51	12.82	13.28
2	136.40	28.90 QP	43.50	-14.60	1.25 H	350	14.66	14.24
3	144.70	26.16 QP	43.50	-17.34	1.16 H	210	10.98	15.18
4	156.80	24.90 QP	43.50	-18.60	1.47 H	9	9.39	15.51
5	199.99	23.97 QP	43.50	-19.53	1.35 H	237	11.58	12.39
6	599.99	26.10 QP	46.00	-19.90	1.20 H	75	1.06	25.04

ANTENNA POLARITY & TEST DISTANCE: VERTICAL AT 3 M

NO.	FREQ. (MHz)	EMISSION LEVEL (dBuV/m)	LIMIT (dBuV/m)	MARGIN (dB)	ANTENNA HEIGHT (m)	TABLE ANGLE (Degree)	RAW VALUE (dBuV)	CORRECTION FACTOR (dB/m)
1	121.97	28.25 QP	43.50	-15.25	1.98 V	65	15.50	12.75
2	126.41	25.14 QP	43.50	-18.36	1.85 V	236	11.93	13.21
3	135.41	24.31 QP	43.50	-19.19	1.98 V	63	10.17	14.14
4	199.98	28.25 QP	43.50	-15.25	1.46 V	231	15.86	12.39
5	259.98	29.64 QP	46.00	-16.36	1.10 V	249	14.91	14.73
6	850.01	27.54 QP	46.00	-18.46	1.28 V	98	-1.25	28.79

- REMARKS:**
1. Emission level (dBuV/m) = Raw Value (dBuV) + Correction Factor (dB/m).
 2. Correction Factor (dB/m) = Antenna Factor (dB/m) + Cable Factor (dB).
 3. The other emission levels were very low against the limit.
 4. Margin value = Emission level – Limit value.



802.11b DSSS MODULATION

EUT TEST CONDITION		MEASUREMENT DETAIL	
CHANNEL	Channel 1	FREQUENCY RANGE	1 ~ 25GHz
INPUT POWER	DC 3.9~4.2V from Battery	DETECTOR FUNCTION	Peak (PK) Average (AV)
ENVIRONMENTAL CONDITIONS	25deg. C, 66%RH 965hPa	TESTED BY	Eric Lee

ANTENNA POLARITY & TEST DISTANCE: HORIZONTAL AT 3 M								
NO.	FREQ. (MHz)	EMISSION LEVEL (dBuV/m)	LIMIT (dBuV/m)	MARGIN (dB)	ANTENNA HEIGHT (m)	TABLE ANGLE (Degree)	RAW VALUE (dBuV)	CORRECTION FACTOR (dB/m)
1	2390.00	54.29 PK	74.00	-19.71	1.69 H	1	23.89	30.40
2	2390.00	43.43 AV	54.00	-10.57	1.69 H	1	13.03	30.40
3	*2412.00	102.50 PK			1.69 H	1	72.01	30.49
4	*2412.00	95.43 AV			1.69 H	1	64.94	30.49
5	4824.00	45.95 PK	74.00	-28.05	1.71 H	322	10.26	35.69
6	4824.00	33.62 AV	54.00	-20.38	1.71 H	322	-2.07	35.69
7	#7236.00	52.37 PK	82.50	-30.13	1.47 H	284	10.13	42.24
8	#7236.00	39.24 AV	75.43	-36.19	1.47 H	284	-3.00	42.24
ANTENNA POLARITY & TEST DISTANCE: VERTICAL AT 3 M								
NO.	FREQ. (MHz)	EMISSION LEVEL (dBuV/m)	LIMIT (dBuV/m)	MARGIN (dB)	ANTENNA HEIGHT (m)	TABLE ANGLE (Degree)	RAW VALUE (dBuV)	CORRECTION FACTOR (dB/m)
1	2390.00	54.19 PK	74.00	-19.81	1.01 V	99	23.79	30.40
2	2390.00	43.24 AV	54.00	-10.76	1.01 V	99	12.84	30.40
3	*2412.00	106.29 PK			1.00 V	79	75.80	30.49
4	*2412.00	100.62 AV			1.00 V	79	70.13	30.49
5	4824.00	46.43 PK	74.00	-27.57	1.40 V	129	10.74	35.69
6	4824.00	34.29 AV	54.00	-19.71	1.40 V	129	-1.40	35.69
7	#7236.00	52.40 PK	86.29	-33.89	1.04 V	23	10.16	42.24
8	#7236.00	38.10 AV	80.62	-42.52	1.04 V	23	-4.14	42.24

- REMARKS:**
1. Emission level (dBuV/m) = Raw Value (dBuV) + Correction Factor (dB/m).
 2. Correction Factor (dB/m) = Antenna Factor (dB/m) + Cable Factor (dB).
 3. The other emission levels were very low against the limit.
 4. Margin value = Emission level – Limit value.
 5. “ * “: Fundamental frequency.
 6. "#":The radiated frequency is out the restricted band.



A D T

EUT TEST CONDITION		MEASUREMENT DETAIL	
CHANNEL	Channel 2	FREQUENCY RANGE	1 ~ 25GHz
INPUT POWER	DC 3.9~4.2V from Battery	DETECTOR FUNCTION	Peak (PK) Average (AV)
ENVIRONMENTAL CONDITIONS	25deg. C, 66%RH 965hPa	TESTED BY	Eric Lee

ANTENNA POLARITY & TEST DISTANCE: HORIZONTAL AT 3 M

NO.	FREQ. (MHz)	EMISSION LEVEL (dBuV/m)	LIMIT (dBuV/m)	MARGIN (dB)	ANTENNA HEIGHT (m)	TABLE ANGLE (Degree)	RAW VALUE (dBuV)	CORRECTION FACTOR (dB/m)
1	2388.00	57.40 PK	74.00	-16.60	1.00 H	198	27.01	30.39
2	2388.00	46.71 AV	54.00	-7.29	1.00 H	198	16.32	30.39
3	*2417.00	107.60 PK			1.00 H	200	77.08	30.52
4	*2417.00	100.79 AV			1.00 H	200	70.27	30.52
5	4834.00	45.84 PK	74.00	-28.16	1.68 H	314	10.13	35.71
6	4834.00	33.57 AV	54.00	-20.43	1.68 H	314	-2.14	35.71
7	7251.00	52.24 PK	74.00	-21.76	1.43 H	284	9.95	42.29
8	7251.00	39.14 AV	54.00	-14.86	1.43 H	284	-3.15	42.29

ANTENNA POLARITY & TEST DISTANCE: VERTICAL AT 3 M

NO.	FREQ. (MHz)	EMISSION LEVEL (dBuV/m)	LIMIT (dBuV/m)	MARGIN (dB)	ANTENNA HEIGHT (m)	TABLE ANGLE (Degree)	RAW VALUE (dBuV)	CORRECTION FACTOR (dB/m)
1	2390.00	59.52 PK	74.00	-14.48	1.02 V	148	29.12	30.40
2	2390.00	48.92 AV	54.00	-5.08	1.02 V	148	18.52	30.40
3	*2417.00	109.70 PK			1.00 V	74	79.18	30.52
4	*2417.00	104.10 AV			1.00 V	74	73.58	30.52
5	4834.00	46.23 PK	74.00	-27.77	1.43 V	131	10.52	35.71
6	4834.00	34.13 AV	54.00	-19.87	1.43 V	131	-1.58	35.71
7	7251.00	53.24 PK	74.00	-20.76	1.04 V	29	10.95	42.29
8	7251.00	38.42 AV	54.00	-15.58	1.04 V	29	-3.87	42.29

- REMARKS:**
1. Emission level (dBuV/m) = Raw Value (dBuV) + Correction Factor (dB/m).
 2. Correction Factor (dB/m) = Antenna Factor (dB/m) + Cable Factor (dB).
 3. The other emission levels were very low against the limit.
 4. Margin value = Emission level – Limit value.
 5. “ * “: Fundamental frequency.



A D T

EUT TEST CONDITION		MEASUREMENT DETAIL	
CHANNEL	Channel 3	FREQUENCY RANGE	1 ~ 25GHz
INPUT POWER	DC 3.9~4.2V from Battery	DETECTOR FUNCTION	Peak (PK) Average (AV)
ENVIRONMENTAL CONDITIONS	25deg. C, 66%RH 965hPa	TESTED BY	Eric Lee

ANTENNA POLARITY & TEST DISTANCE: HORIZONTAL AT 3 M								
NO.	FREQ. (MHz)	EMISSION LEVEL (dBuV/m)	LIMIT (dBuV/m)	MARGIN (dB)	ANTENNA HEIGHT (m)	TABLE ANGLE (Degree)	RAW VALUE (dBuV)	CORRECTION FACTOR (dB/m)
1	2382.00	55.88 PK	74.00	-18.12	1.74 H	348	25.52	30.36
2	2382.00	44.80 AV	54.00	-9.20	1.74 H	348	14.44	30.36
3	*2422.00	109.60 PK			1.73 H	341	79.06	30.54
4	*2422.00	102.80 AV			1.73 H	341	72.26	30.54
5	4844.00	47.12 PK	74.00	-26.88	1.64 H	314	11.38	35.74
6	4844.00	35.63 AV	54.00	-18.37	1.64 H	314	-0.11	35.74
7	7266.00	52.37 PK	74.00	-21.63	1.44 H	296	10.02	42.35
8	7266.00	39.23 AV	54.00	-14.77	1.44 H	296	-3.12	42.35
ANTENNA POLARITY & TEST DISTANCE: VERTICAL AT 3 M								
NO.	FREQ. (MHz)	EMISSION LEVEL (dBuV/m)	LIMIT (dBuV/m)	MARGIN (dB)	ANTENNA HEIGHT (m)	TABLE ANGLE (Degree)	RAW VALUE (dBuV)	CORRECTION FACTOR (dB/m)
1	2382.00	58.33 PK	74.00	-15.67	1.02 V	149	27.97	30.36
2	2382.00	47.90 AV	54.00	-6.10	1.02 V	149	17.54	30.36
3	*2422.00	110.80 PK			1.04 V	83	80.26	30.54
4	*2422.00	106.30 AV			1.04 V	83	75.76	30.54
5	4844.00	47.93 PK	74.00	-26.07	1.37 V	124	12.19	35.74
6	4844.00	36.21 AV	54.00	-17.79	1.37 V	124	0.47	35.74
7	7266.00	52.84 PK	74.00	-21.16	1.07 V	34	10.49	42.35
8	7266.00	38.24 AV	54.00	-15.76	1.07 V	34	-4.11	42.35

- REMARKS:**
1. Emission level (dBuV/m) = Raw Value (dBuV) + Correction Factor (dB/m).
 2. Correction Factor (dB/m) = Antenna Factor (dB/m) + Cable Factor (dB).
 3. The other emission levels were very low against the limit.
 4. Margin value = Emission level – Limit value.
 5. “ * “: Fundamental frequency.



A D T

EUT TEST CONDITION		MEASUREMENT DETAIL	
CHANNEL	Channel 6	FREQUENCY RANGE	1 ~ 25GHz
INPUT POWER	DC 3.9~4.2V from Battery	DETECTOR FUNCTION	Peak (PK) Average (AV)
ENVIRONMENTAL CONDITIONS	25deg. C, 66%RH 965hPa	TESTED BY	Eric Lee

ANTENNA POLARITY & TEST DISTANCE: HORIZONTAL AT 3 M								
NO.	FREQ. (MHz)	EMISSION LEVEL (dBuV/m)	LIMIT (dBuV/m)	MARGIN (dB)	ANTENNA HEIGHT (m)	TABLE ANGLE (Degree)	RAW VALUE (dBuV)	CORRECTION FACTOR (dB/m)
1	*2437.00	107.95 PK			1.72 H	0	77.34	30.61
2	*2437.00	100.65 AV			1.72 H	0	70.04	30.61
3	4874.00	47.29 PK	74.00	-26.71	1.68 H	318	11.49	35.80
4	4874.00	35.98 AV	54.00	-18.02	1.68 H	318	0.18	35.80
5	7311.00	52.22 PK	74.00	-21.78	1.47 H	298	9.70	42.52
6	7311.00	39.05 AV	54.00	-14.95	1.47 H	298	-3.47	42.52

ANTENNA POLARITY & TEST DISTANCE: VERTICAL AT 3 M								
NO.	FREQ. (MHz)	EMISSION LEVEL (dBuV/m)	LIMIT (dBuV/m)	MARGIN (dB)	ANTENNA HEIGHT (m)	TABLE ANGLE (Degree)	RAW VALUE (dBuV)	CORRECTION FACTOR (dB/m)
1	*2437.00	111.61 PK			1.00 V	84	81.00	30.61
2	*2437.00	105.11 AV			1.00 V	84	74.50	30.61
3	4874.00	48.60 PK	74.00	-25.40	1.53 V	326	12.80	35.80
4	4874.00	36.99 AV	54.00	-17.01	1.53 V	326	1.19	35.80
5	7311.00	52.19 PK	74.00	-21.81	1.01 V	11	9.67	42.52
6	7311.00	37.94 AV	54.00	-16.06	1.01 V	11	-4.58	42.52

- REMARKS:**
1. Emission level (dBuV/m) = Raw Value (dBuV) + Correction Factor (dB/m).
 2. Correction Factor (dB/m) = Antenna Factor (dB/m) + Cable Factor (dB).
 3. The other emission levels were very low against the limit.
 4. Margin value = Emission level – Limit value.
 5. “ * “: Fundamental frequency.



A D T

EUT TEST CONDITION		MEASUREMENT DETAIL	
CHANNEL	Channel 10	FREQUENCY RANGE	1 ~ 25GHz
INPUT POWER	DC 3.9~4.2V from Battery	DETECTOR FUNCTION	Peak (PK) Average (AV)
ENVIRONMENTAL CONDITIONS	22deg. C, 68%RH 965hPa	TESTED BY	Duke Tseng

ANTENNA POLARITY & TEST DISTANCE: HORIZONTAL AT 3 M								
NO.	FREQ. (MHz)	EMISSION LEVEL (dBuV/m)	LIMIT (dBuV/m)	MARGIN (dB)	ANTENNA HEIGHT (m)	TABLE ANGLE (Degree)	RAW VALUE (dBuV)	CORRECTION FACTOR (dB/m)
1	*2457.00	106.70 PK			1.76 H	342	76.00	30.70
2	*2457.00	100.60 AV			1.76 H	342	69.90	30.70
3	2483.50	54.86 PK	74.00	-19.14	1.73 H	339	24.04	30.82
4	2483.50	44.78 AV	54.00	-9.22	1.73 H	339	13.96	30.82
5	4914.00	47.13 PK	74.00	-26.87	1.62 H	310	11.25	35.88
6	4914.00	35.26 AV	54.00	-18.74	1.62 H	310	-0.62	35.88
7	7371.00	52.63 PK	74.00	-21.37	1.43 H	284	9.89	42.74
8	7371.00	38.22 AV	54.00	-15.78	1.43 H	284	-4.52	42.74
ANTENNA POLARITY & TEST DISTANCE: VERTICAL AT 3 M								
NO.	FREQ. (MHz)	EMISSION LEVEL (dBuV/m)	LIMIT (dBuV/m)	MARGIN (dB)	ANTENNA HEIGHT (m)	TABLE ANGLE (Degree)	RAW VALUE (dBuV)	CORRECTION FACTOR (dB/m)
1	*2457.00	110.70 PK			1.03 V	94	80.00	30.70
2	*2457.00	106.10 AV			1.03 V	94	75.40	30.70
3	2483.50	60.16 PK	74.00	-13.84	1.01 V	147	29.34	30.82
4	2483.50	47.11 AV	54.00	-6.89	1.01 V	147	16.29	30.82
5	4914.00	47.72 PK	74.00	-26.28	1.27 V	129	11.84	35.88
6	4914.00	35.63 AV	54.00	-18.37	1.27 V	129	-0.25	35.88
7	7371.00	52.23 PK	74.00	-21.77	1.04 V	31	9.49	42.74
8	7371.00	37.93 AV	54.00	-16.07	1.04 V	31	-4.81	42.74

- REMARKS:**
1. Emission level (dBuV/m) = Raw Value (dBuV) + Correction Factor (dB/m).
 2. Correction Factor (dB/m) = Antenna Factor (dB/m) + Cable Factor (dB).
 3. The other emission levels were very low against the limit.
 4. Margin value = Emission level – Limit value.
 5. “ * “: Fundamental frequency.



A D T

EUT TEST CONDITION		MEASUREMENT DETAIL	
CHANNEL	Channel 11	FREQUENCY RANGE	1 ~ 25GHz
INPUT POWER	DC 3.9~4.2V from Battery	DETECTOR FUNCTION	Peak (PK) Average (AV)
ENVIRONMENTAL CONDITIONS	25deg. C, 66%RH 965hPa	TESTED BY	Eric Lee

ANTENNA POLARITY & TEST DISTANCE: HORIZONTAL AT 3 M								
NO.	FREQ. (MHz)	EMISSION LEVEL (dBuV/m)	LIMIT (dBuV/m)	MARGIN (dB)	ANTENNA HEIGHT (m)	TABLE ANGLE (Degree)	RAW VALUE (dBuV)	CORRECTION FACTOR (dB/m)
1	*2462.00	102.47 PK			1.01 H	79	71.75	30.72
2	*2462.00	94.98 AV			1.01 H	79	64.26	30.72
3	2493.90	55.91 PK	74.00	-18.09	1.02 H	95	25.09	30.86
4	2493.90	43.93 AV	54.00	-10.07	1.02 H	95	13.07	30.86
5	4924.00	46.58 PK	74.00	-27.42	1.49 H	138	10.68	35.90
6	4924.00	34.11 AV	54.00	-19.89	1.49 H	138	-1.79	35.90
7	7386.00	52.08 PK	74.00	-21.92	1.11 H	63	9.28	42.80
8	7386.00	37.11 AV	54.00	-16.89	1.11 H	63	-5.69	42.80
ANTENNA POLARITY & TEST DISTANCE: VERTICAL AT 3 M								
NO.	FREQ. (MHz)	EMISSION LEVEL (dBuV/m)	LIMIT (dBuV/m)	MARGIN (dB)	ANTENNA HEIGHT (m)	TABLE ANGLE (Degree)	RAW VALUE (dBuV)	CORRECTION FACTOR (dB/m)
1	*2462.00	106.27 PK			1.68 V	58	75.55	30.72
2	*2462.00	100.85 AV			1.68 V	58	70.13	30.72
3	2483.50	55.42 PK	74.00	-18.58	1.73 V	15	24.56	30.82
4	2483.50	43.93 AV	54.00	-10.07	1.73 V	15	13.11	30.82
5	4924.00	45.58 PK	74.00	-28.42	1.69 V	350	9.68	35.90
6	4924.00	33.72 AV	54.00	-20.28	1.69 V	350	-2.18	35.90
7	7386.00	52.61 PK	74.00	-21.39	1.53 V	271	9.81	42.80
8	7386.00	38.65 AV	54.00	-15.35	1.53 V	271	-4.15	42.80

- REMARKS:**
1. Emission level (dBuV/m) = Raw Value (dBuV) + Correction Factor (dB/m).
 2. Correction Factor (dB/m) = Antenna Factor (dB/m) + Cable Factor (dB).
 3. The other emission levels were very low against the limit.
 4. Margin value = Emission level – Limit value.
 5. “ * “: Fundamental frequency.



A D T

RESTRICTED BANDEDGE (802.11b MODE, CH 1, HORIZONTAL)

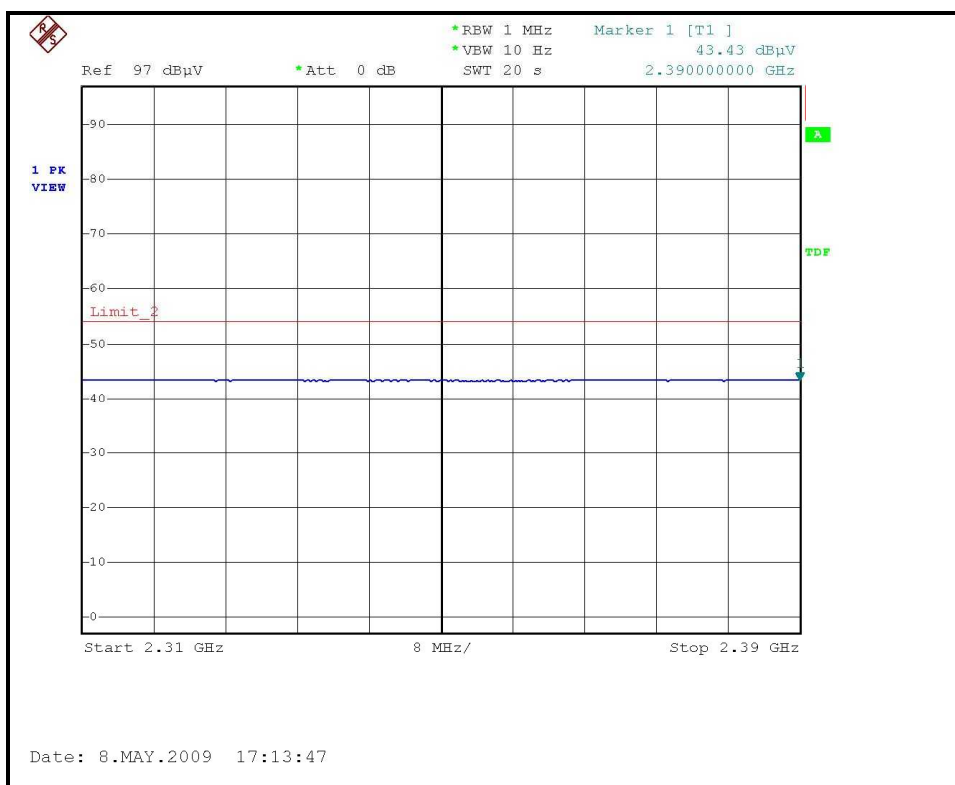
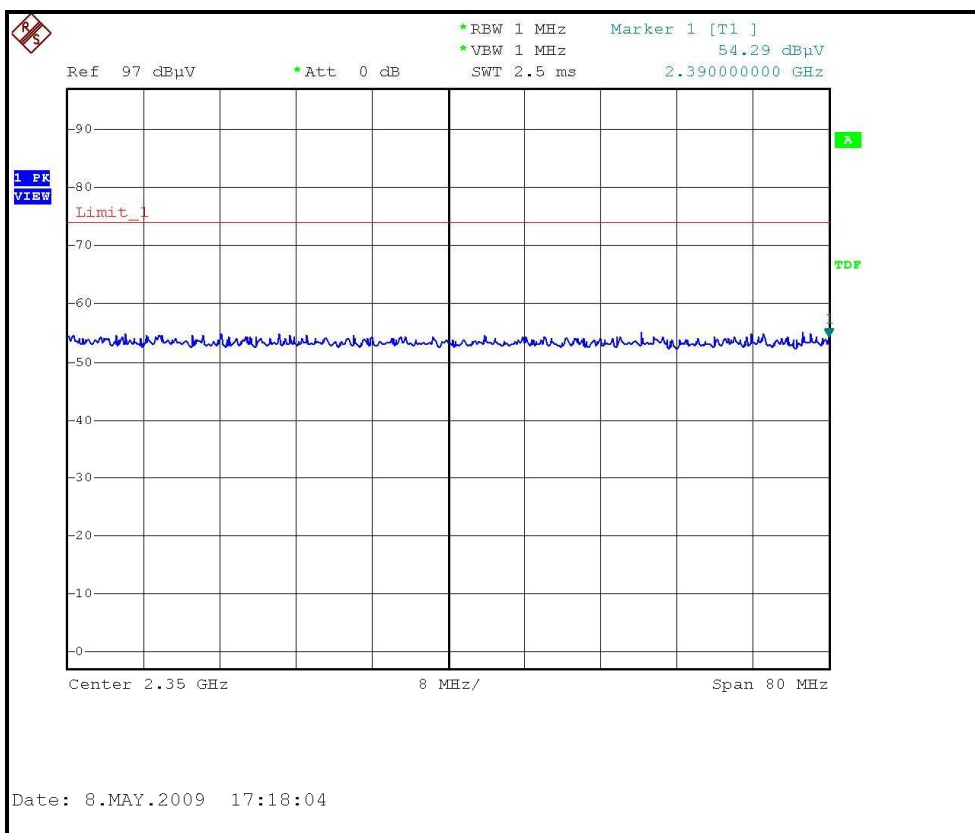



A D T

RESTRICTED BANDEDGE (802.11b MODE, CH 1, VERTICAL)

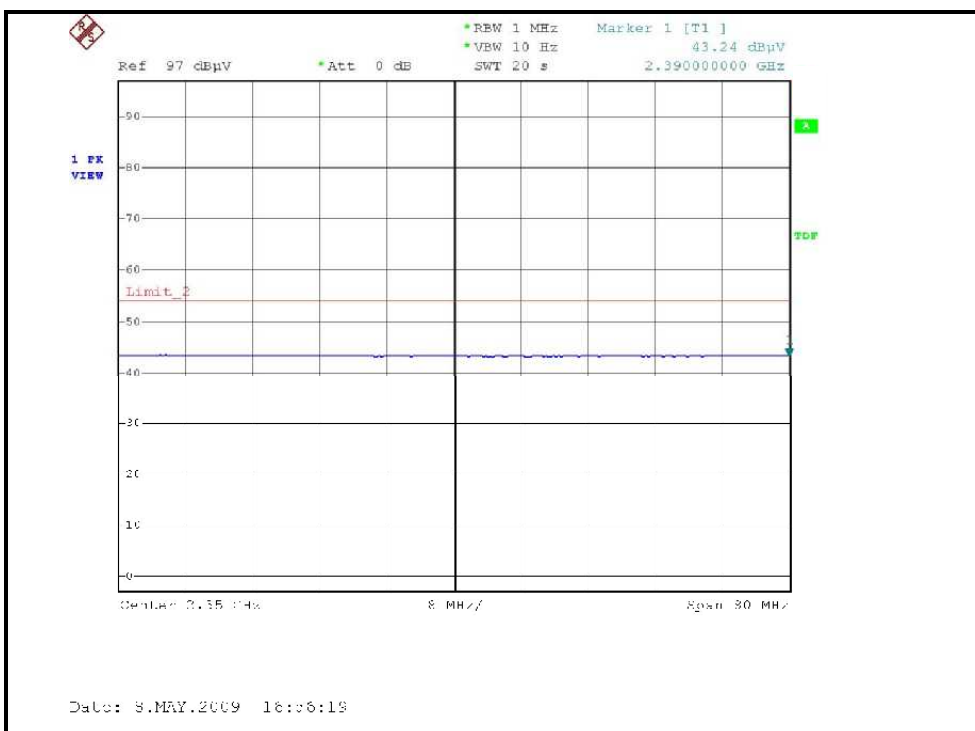
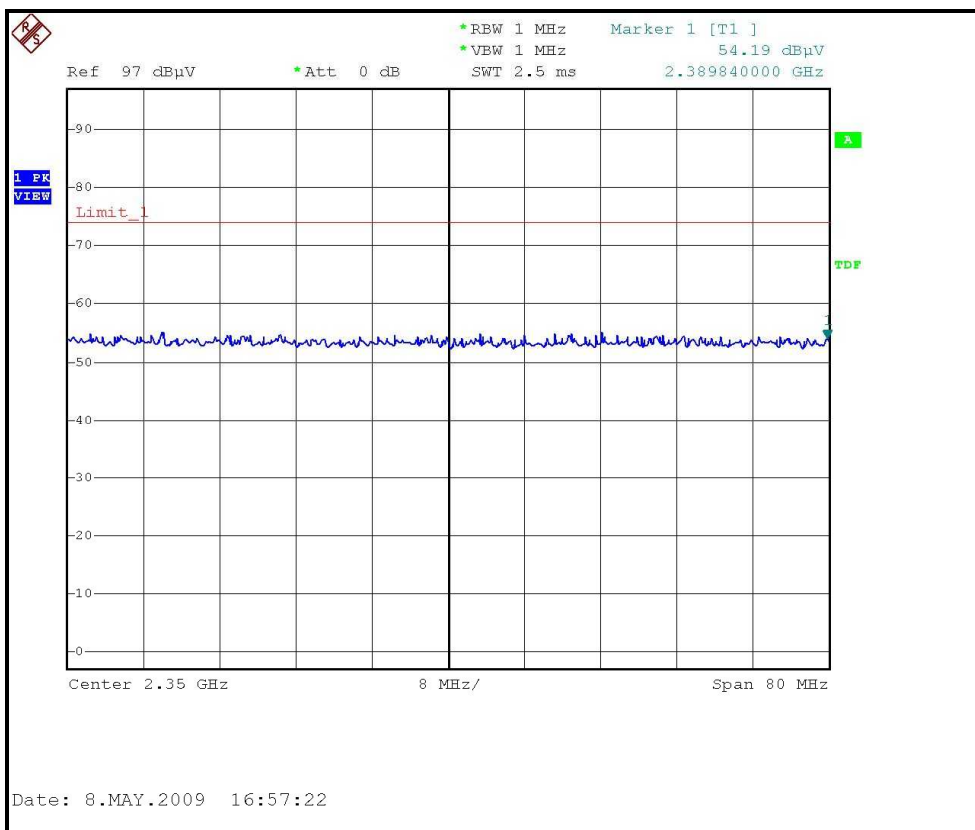



A D T

RESTRICTED BANDEDGE (802.11b MODE,CH 2, HORIZONTAL)

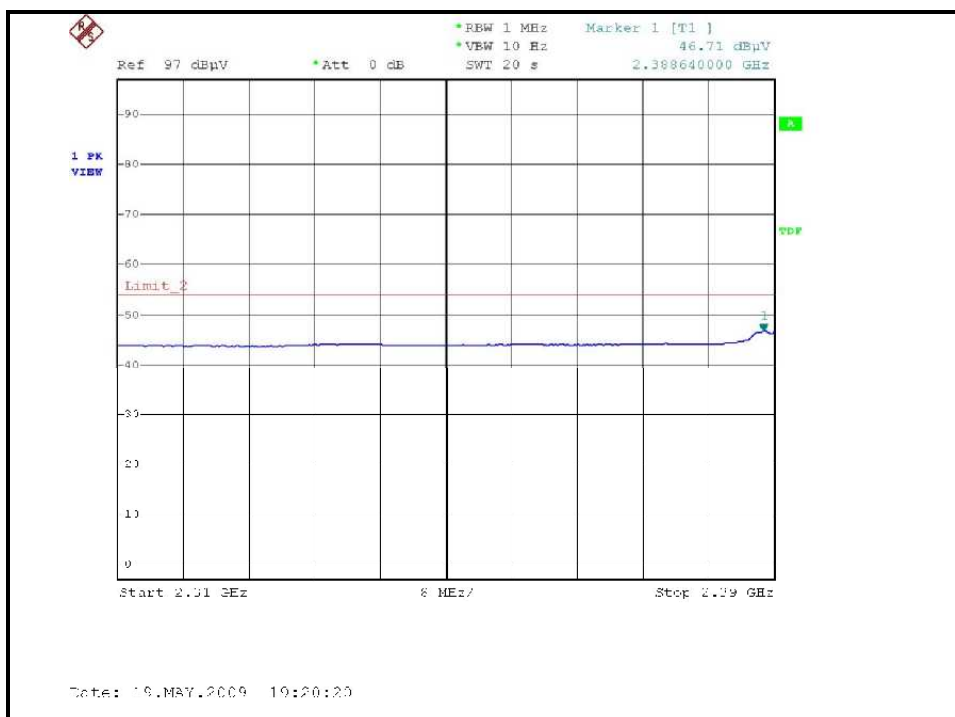
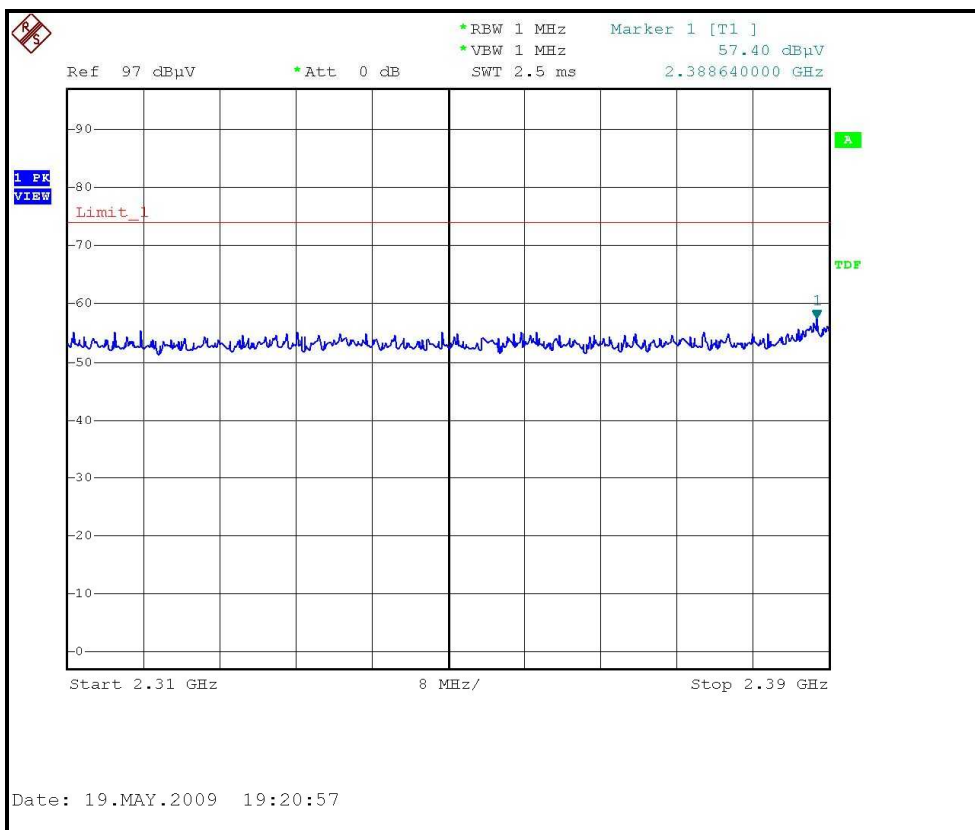



A D T

RESTRICTED BANDEDGE (802.11b MODE, CH 2, VERTICAL)

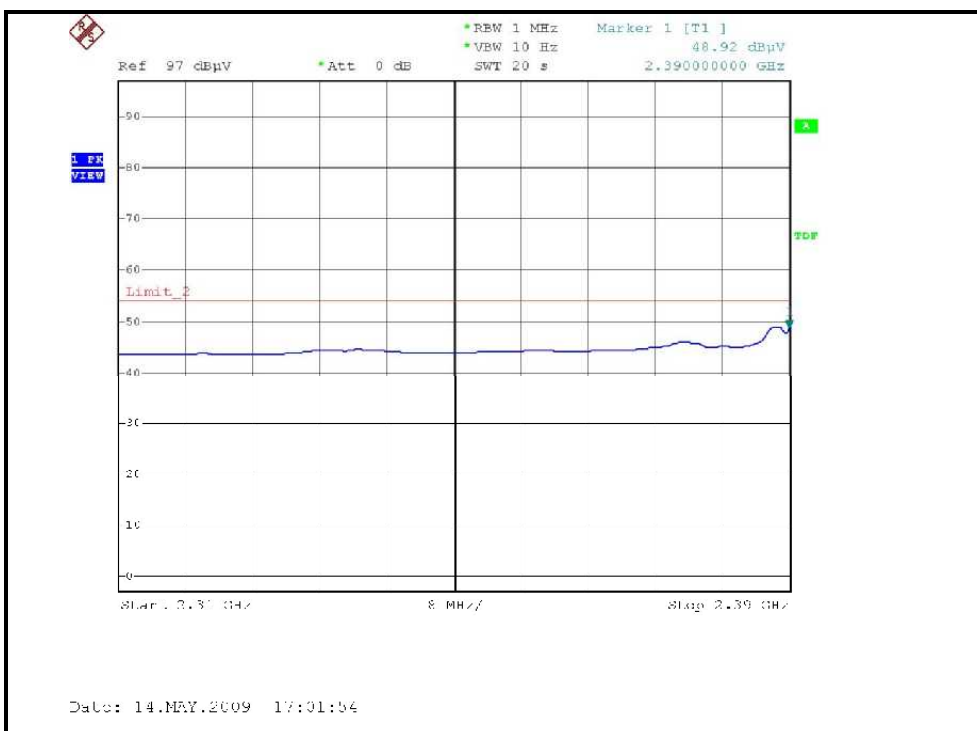
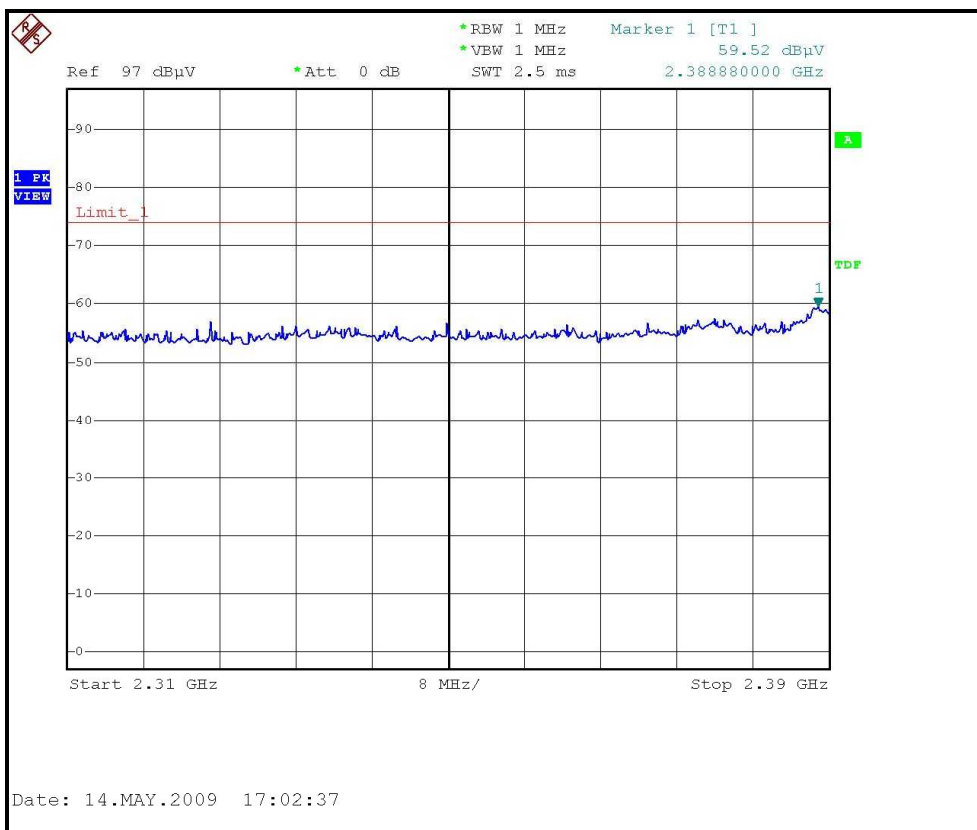



A D T

RESTRICTED BANDEDGE (802.11b MODE, CH 3, VERTICAL)

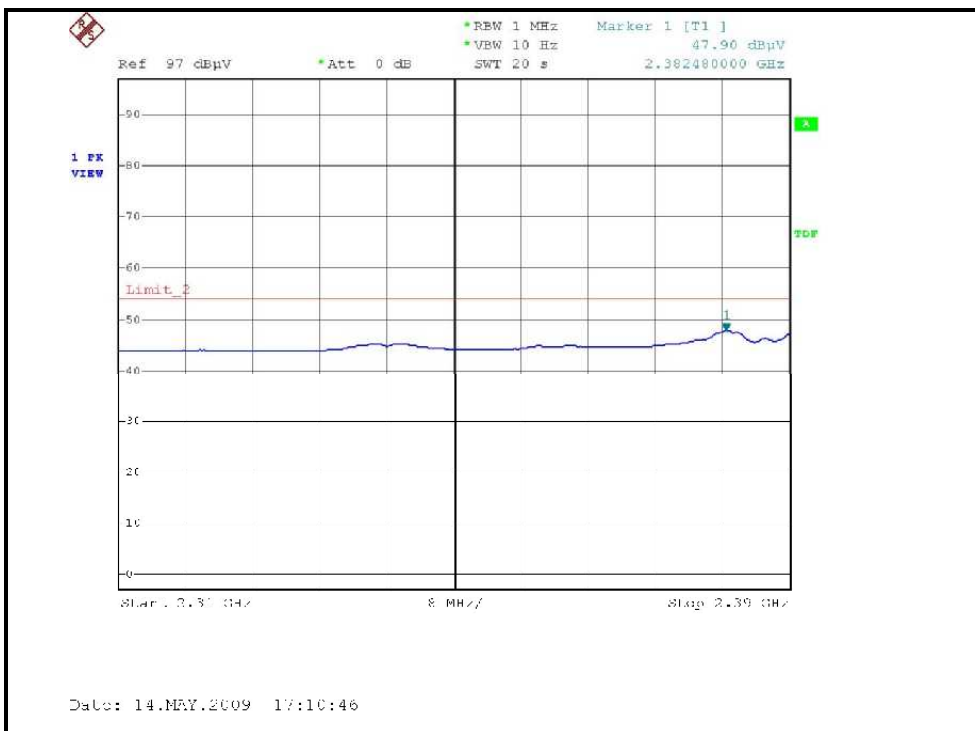
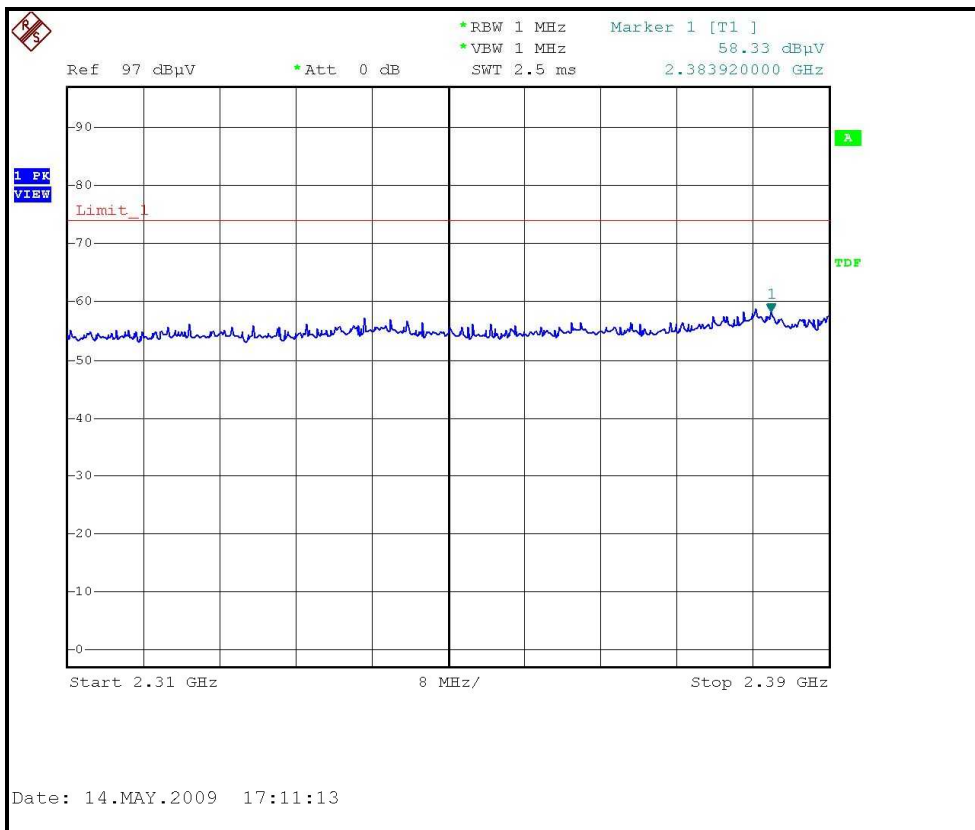



A D T

RESTRICTED BANDEDGE (802.11b MODE,CH 10, HORIZONTAL)

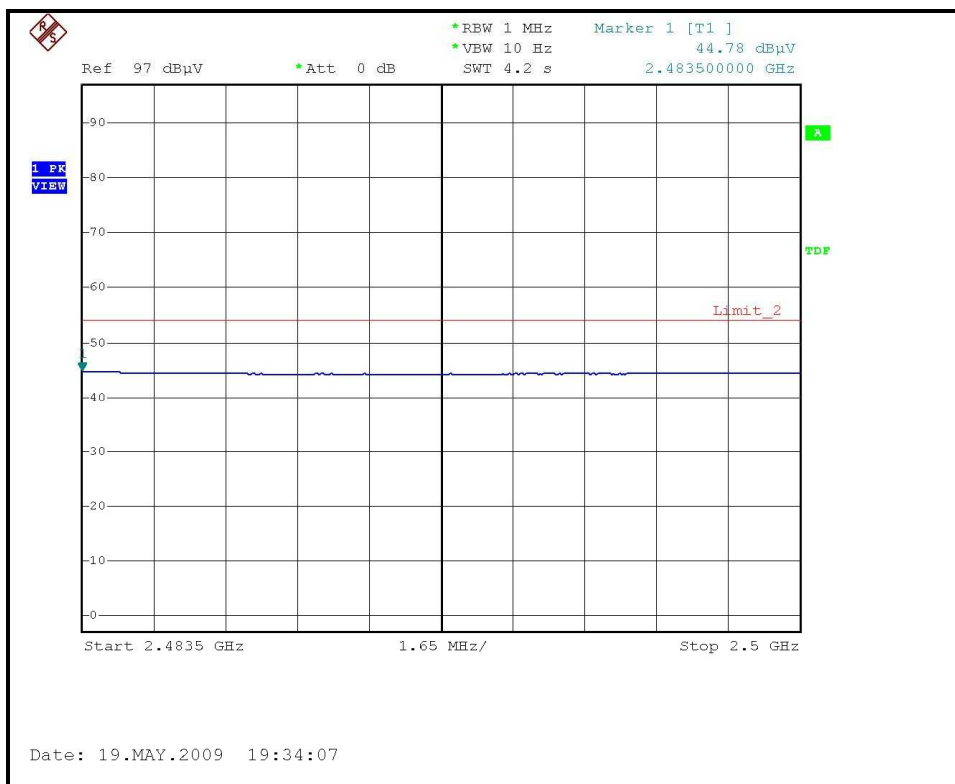
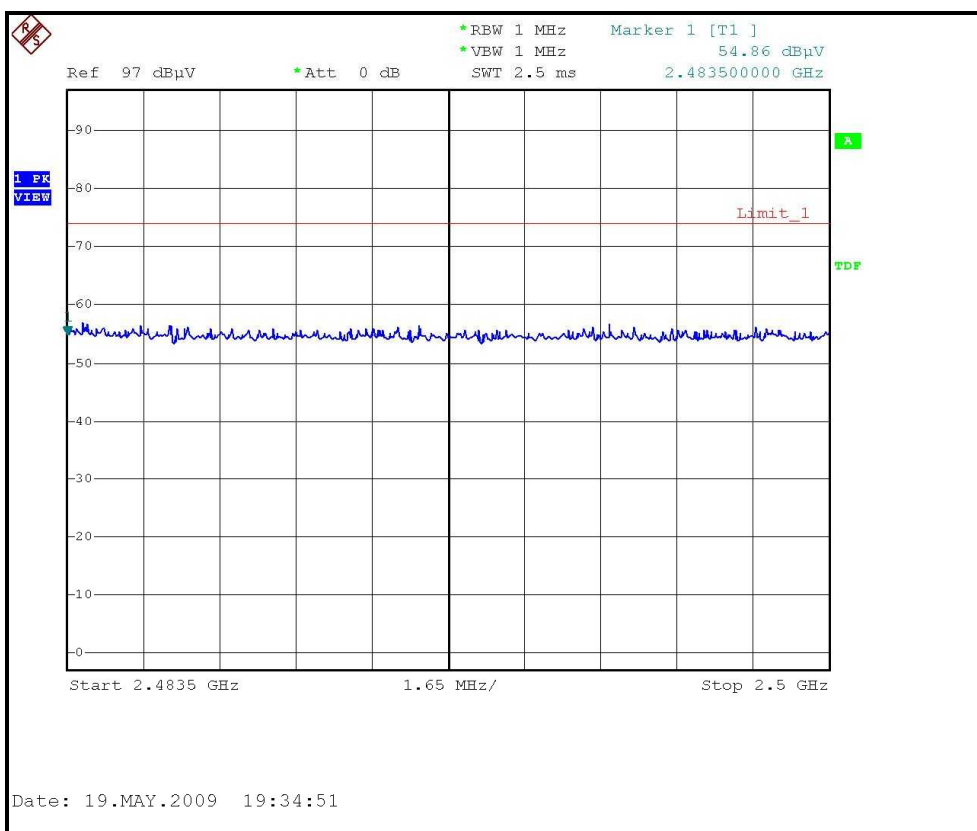



A D T

RESTRICTED BANDEDGE (802.11b MODE, CH 10, VERTICAL)

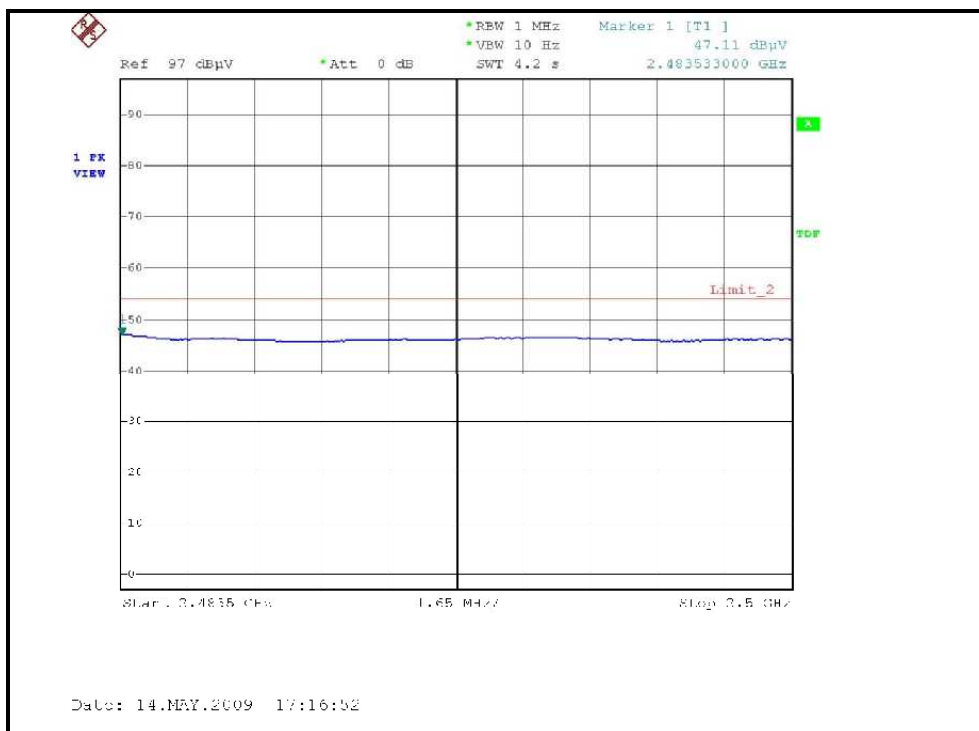
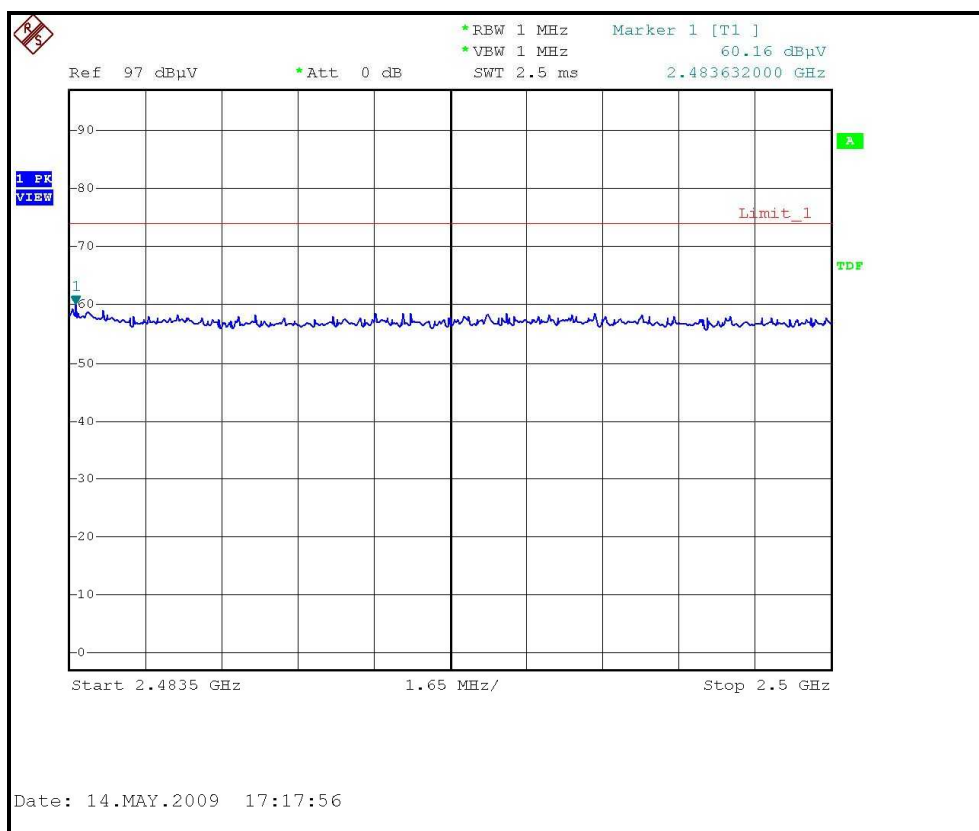



A D T

RESTRICTED BANDEDGE (802.11b MODE, CH 11, VERTICAL)

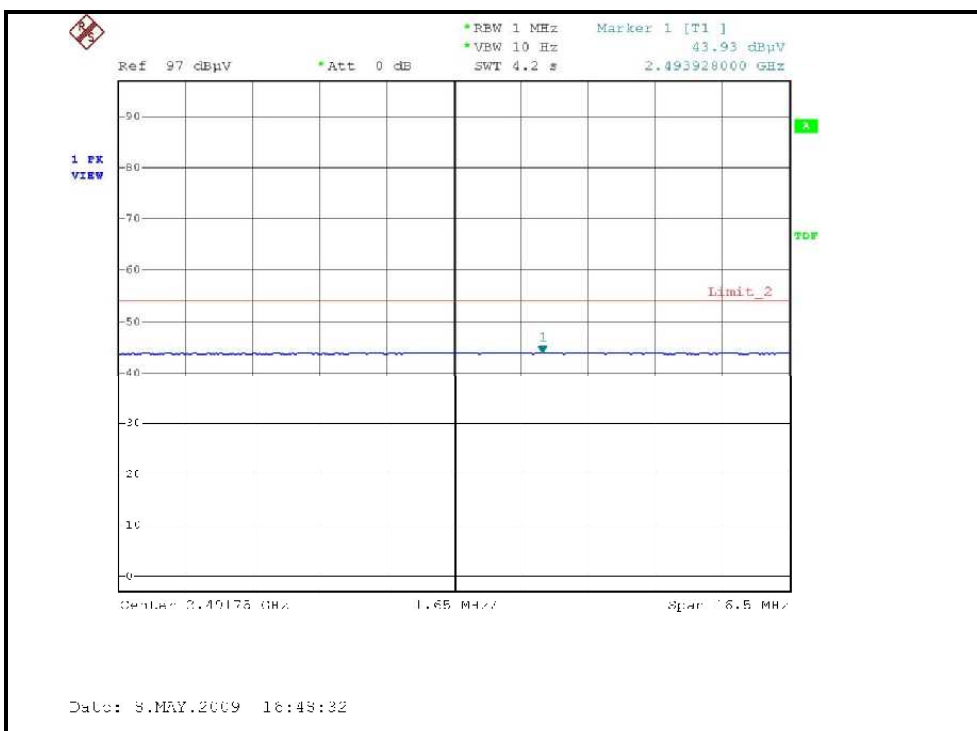
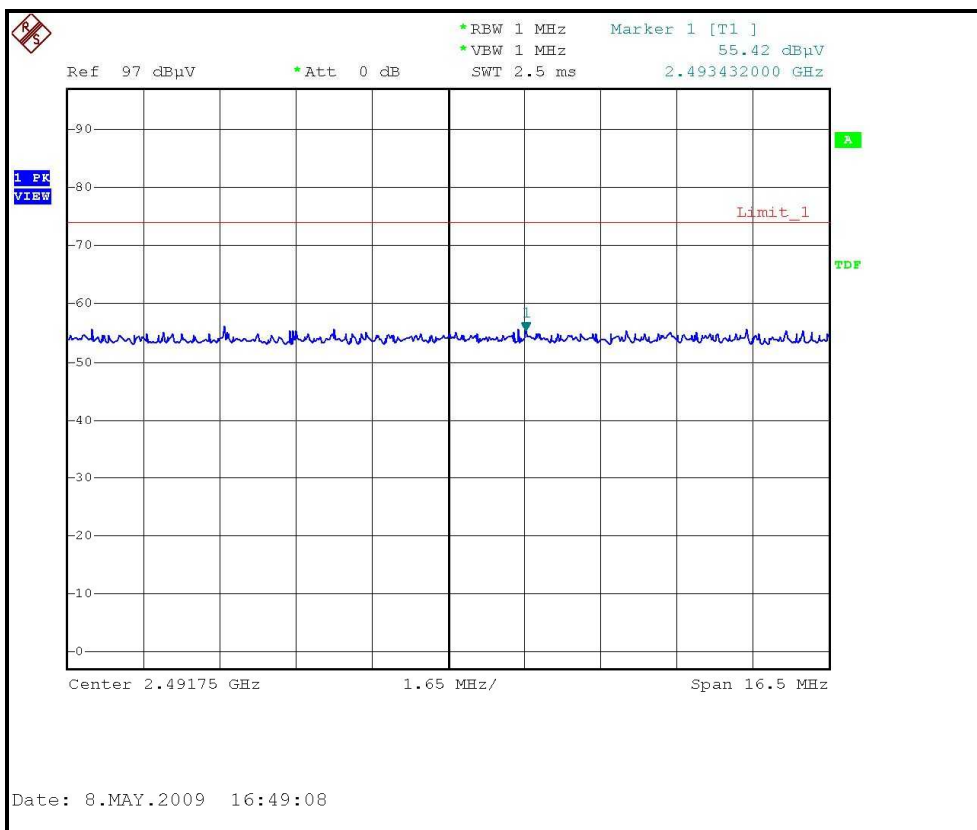



802.11g OFDM MODULATION

EUT TEST CONDITION		MEASUREMENT DETAIL	
CHANNEL	Channel 1	FREQUENCY RANGE	1 ~ 25GHz
INPUT POWER	DC 3.9~4.2V from Battery	DETECTOR FUNCTION	Peak (PK) Average (AV)
ENVIRONMENTAL CONDITIONS	25deg. C, 66%RH 965hPa	TESTED BY	Eric Lee

ANTENNA POLARITY & TEST DISTANCE: HORIZONTAL AT 3 M								
NO.	FREQ. (MHz)	EMISSION LEVEL (dBuV/m)	LIMIT (dBuV/m)	MARGIN (dB)	ANTENNA HEIGHT (m)	TABLE ANGLE (Degree)	RAW VALUE (dBuV)	CORRECTION FACTOR (dB/m)
1	2390.00	63.32 PK	74.00	-10.68	1.11 H	68	32.92	30.40
2	2390.00	46.99 AV	54.00	-7.01	1.11 H	68	16.59	30.40
3	*2412.00	101.62 PK			1.65 H	358	71.13	30.49
4	*2412.00	92.58 AV			1.65 H	358	62.09	30.49
5	4824.00	44.91 PK	74.00	-29.09	1.39 H	204	9.22	35.69
6	4824.00	33.02 AV	54.00	-20.98	1.39 H	204	-2.67	35.69
7	#7236.00	53.10 PK	81.62	-28.52	1.41 H	29	10.86	42.24
8	#7236.00	38.93 AV	72.58	-33.65	1.41 H	29	-3.31	42.24
ANTENNA POLARITY & TEST DISTANCE: VERTICAL AT 3 M								
NO.	FREQ. (MHz)	EMISSION LEVEL (dBuV/m)	LIMIT (dBuV/m)	MARGIN (dB)	ANTENNA HEIGHT (m)	TABLE ANGLE (Degree)	RAW VALUE (dBuV)	CORRECTION FACTOR (dB/m)
1	2390.00	63.66 PK	74.00	-10.34	1.05 V	5	33.26	30.40
2	2390.00	48.92 AV	54.00	-5.08	1.05 V	5	18.52	30.40
3	*2412.00	105.68 PK			1.03 V	199	75.19	30.49
4	*2412.00	96.29 AV			1.03 V	199	65.80	30.49
5	4824.00	44.11 PK	74.00	-29.89	1.19 V	28	8.42	35.69
6	4824.00	32.22 AV	54.00	-21.78	1.19 V	28	-3.47	35.69
7	#7236.00	51.62 PK	85.68	-34.06	1.21 V	32	9.38	42.24
8	#7236.00	38.10 AV	76.29	-38.19	1.21 V	32	-4.14	42.24

- REMARKS:**
1. Emission level (dBuV/m) = Raw Value (dBuV) + Correction Factor (dB/m).
 2. Correction Factor (dB/m) = Antenna Factor (dB/m) + Cable Factor (dB).
 3. The other emission levels were very low against the limit.
 4. Margin value = Emission level – Limit value.
 5. “ * “: Fundamental frequency.
 6. "#":The radiated frequency is out the restricted band.



A D T

EUT TEST CONDITION		MEASUREMENT DETAIL	
CHANNEL	Channel 2	FREQUENCY RANGE	1 ~ 25GHz
INPUT POWER	DC 3.9~4.2V from Battery	DETECTOR FUNCTION	Peak (PK) Average (AV)
ENVIRONMENTAL CONDITIONS	25deg. C, 66%RH 965hPa	TESTED BY	Eric Lee

ANTENNA POLARITY & TEST DISTANCE: HORIZONTAL AT 3 M								
NO.	FREQ. (MHz)	EMISSION LEVEL (dBuV/m)	LIMIT (dBuV/m)	MARGIN (dB)	ANTENNA HEIGHT (m)	TABLE ANGLE (Degree)	RAW VALUE (dBuV)	CORRECTION FACTOR (dB/m)
1	2390.00	62.54 PK	74.00	-11.46	1.73 H	344	32.14	30.40
2	2390.00	47.76 AV	54.00	-6.24	1.73 H	344	17.36	30.40
3	*2417.00	106.00 PK			1.72 H	342	75.48	30.52
4	*2417.00	96.10 AV			1.72 H	342	65.58	30.52
5	4834.00	45.93 PK	74.00	-28.07	1.64 H	321	10.22	35.71
6	4834.00	33.84 AV	54.00	-20.16	1.64 H	321	-1.87	35.71
7	7251.00	52.54 PK	74.00	-21.46	1.41 H	274	10.25	42.29
8	7251.00	39.27 AV	54.00	-14.73	1.41 H	274	-3.02	42.29
ANTENNA POLARITY & TEST DISTANCE: VERTICAL AT 3 M								
NO.	FREQ. (MHz)	EMISSION LEVEL (dBuV/m)	LIMIT (dBuV/m)	MARGIN (dB)	ANTENNA HEIGHT (m)	TABLE ANGLE (Degree)	RAW VALUE (dBuV)	CORRECTION FACTOR (dB/m)
1	2390.00	64.70 PK	74.00	-9.30	1.02 V	148	34.30	30.40
2	2390.00	49.79 AV	54.00	-4.21	1.02 V	148	19.39	30.40
3	*2417.00	107.30 PK			1.04 V	183	76.78	30.52
4	*2417.00	98.24 AV			1.04 V	183	67.72	30.52
5	4834.00	46.12 PK	74.00	-27.88	1.62 V	134	10.41	35.71
6	4834.00	34.27 AV	54.00	-19.73	1.62 V	134	-1.44	35.71
7	7251.00	52.13 PK	74.00	-21.87	1.01 V	32	9.84	42.29
8	7251.00	38.42 AV	54.00	-15.58	1.01 V	32	-3.87	42.29

- REMARKS:**
1. Emission level (dBuV/m) = Raw Value (dBuV) + Correction Factor (dB/m).
 2. Correction Factor (dB/m) = Antenna Factor (dB/m) + Cable Factor (dB).
 3. The other emission levels were very low against the limit.
 4. Margin value = Emission level – Limit value.
 5. “ * “: Fundamental frequency.



A D T

EUT TEST CONDITION		MEASUREMENT DETAIL	
CHANNEL	Channel 3	FREQUENCY RANGE	1 ~ 25GHz
INPUT POWER	DC 3.9~4.2V from Battery	DETECTOR FUNCTION	Peak (PK) Average (AV)
ENVIRONMENTAL CONDITIONS	25deg. C, 66%RH 965hPa	TESTED BY	Eric Lee

ANTENNA POLARITY & TEST DISTANCE: HORIZONTAL AT 3 M								
NO.	FREQ. (MHz)	EMISSION LEVEL (dBuV/m)	LIMIT (dBuV/m)	MARGIN (dB)	ANTENNA HEIGHT (m)	TABLE ANGLE (Degree)	RAW VALUE (dBuV)	CORRECTION FACTOR (dB/m)
1	2390.00	61.21 PK	74.00	-12.79	1.74 H	343	30.81	30.40
2	2390.00	47.04 AV	54.00	-6.96	1.74 H	343	16.64	30.40
3	*2422.00	107.30 PK			1.74 H	341	76.76	30.54
4	*2422.00	97.50 AV			1.74 H	341	66.96	30.54
5	4844.00	45.84 PK	74.00	-28.16	1.62 H	313	10.10	35.74
6	4844.00	33.78 AV	54.00	-20.22	1.62 H	313	-1.96	35.74
7	7266.00	52.23 PK	74.00	-21.77	1.37 H	269	9.88	42.35
8	7266.00	39.03 AV	54.00	-14.97	1.37 H	269	-3.32	42.35
ANTENNA POLARITY & TEST DISTANCE: VERTICAL AT 3 M								
NO.	FREQ. (MHz)	EMISSION LEVEL (dBuV/m)	LIMIT (dBuV/m)	MARGIN (dB)	ANTENNA HEIGHT (m)	TABLE ANGLE (Degree)	RAW VALUE (dBuV)	CORRECTION FACTOR (dB/m)
1	2390.00	65.50 PK	74.00	-8.50	1.00 V	81	35.10	30.40
2	2390.00	49.77 AV	54.00	-4.23	1.00 V	81	19.37	30.40
3	*2422.00	107.70 PK			1.03 V	167	77.16	30.54
4	*2422.00	98.60 AV			1.03 V	167	68.06	30.54
5	4844.00	46.00 PK	74.00	-28.00	1.63 V	131	10.26	35.74
6	4844.00	34.16 AV	54.00	-19.84	1.63 V	131	-1.58	35.74
7	7266.00	51.89 PK	74.00	-22.11	1.34 V	36	9.54	42.35
8	7266.00	38.92 AV	54.00	-15.08	1.34 V	36	-3.43	42.35

- REMARKS:**
1. Emission level (dBuV/m) = Raw Value (dBuV) + Correction Factor (dB/m).
 2. Correction Factor (dB/m) = Antenna Factor (dB/m) + Cable Factor (dB).
 3. The other emission levels were very low against the limit.
 4. Margin value = Emission level – Limit value.
 5. “ * “: Fundamental frequency.



A D T

EUT TEST CONDITION		MEASUREMENT DETAIL	
CHANNEL	Channel 6	FREQUENCY RANGE	1 ~ 25GHz
INPUT POWER	DC 3.9~4.2V from Battery	DETECTOR FUNCTION	Peak (PK) Average (AV)
ENVIRONMENTAL CONDITIONS	25deg. C, 66%RH 965hPa	TESTED BY	Eric Lee

ANTENNA POLARITY & TEST DISTANCE: HORIZONTAL AT 3 M								
NO.	FREQ. (MHz)	EMISSION LEVEL (dBuV/m)	LIMIT (dBuV/m)	MARGIN (dB)	ANTENNA HEIGHT (m)	TABLE ANGLE (Degree)	RAW VALUE (dBuV)	CORRECTION FACTOR (dB/m)
1	*2437.00	107.34 PK			1.71 H	350	76.73	30.61
2	*2437.00	98.00 AV			1.71 H	350	67.39	30.61
3	4874.00	46.11 PK	74.00	-27.89	1.35 H	154	10.31	35.80
4	4874.00	33.85 AV	54.00	-20.15	1.35 H	154	-1.95	35.80
5	7311.00	53.69 PK	74.00	-20.31	1.42 H	19	11.17	42.52
6	7311.00	39.72 AV	54.00	-14.28	1.42 H	19	-2.80	42.52

ANTENNA POLARITY & TEST DISTANCE: VERTICAL AT 3 M								
NO.	FREQ. (MHz)	EMISSION LEVEL (dBuV/m)	LIMIT (dBuV/m)	MARGIN (dB)	ANTENNA HEIGHT (m)	TABLE ANGLE (Degree)	RAW VALUE (dBuV)	CORRECTION FACTOR (dB/m)
1	*2437.00	110.71 PK			1.01 V	182	80.10	30.61
2	*2437.00	101.46 AV			1.01 V	182	70.85	30.61
3	4874.00	45.23 PK	74.00	-28.77	1.22 V	303	9.43	35.80
4	4874.00	32.49 AV	54.00	-21.51	1.22 V	303	-3.31	35.80
5	7311.00	51.64 PK	74.00	-22.36	1.24 V	59	9.12	42.52
6	7311.00	38.18 AV	54.00	-15.82	1.24 V	59	-4.34	42.52

- REMARKS:**
1. Emission level (dBuV/m) = Raw Value (dBuV) + Correction Factor (dB/m).
 2. Correction Factor (dB/m) = Antenna Factor (dB/m) + Cable Factor (dB).
 3. The other emission levels were very low against the limit.
 4. Margin value = Emission level – Limit value.
 5. “ * “: Fundamental frequency.



A D T

EUT TEST CONDITION		MEASUREMENT DETAIL	
CHANNEL	Channel 10	FREQUENCY RANGE	1 ~ 25GHz
INPUT POWER	DC 3.9~4.2V from Battery	DETECTOR FUNCTION	Peak (PK) Average (AV)
ENVIRONMENTAL CONDITIONS	22deg. C, 68%RH 965hPa	TESTED BY	Duke Tseng

ANTENNA POLARITY & TEST DISTANCE: HORIZONTAL AT 3 M								
NO.	FREQ. (MHz)	EMISSION LEVEL (dBuV/m)	LIMIT (dBuV/m)	MARGIN (dB)	ANTENNA HEIGHT (m)	TABLE ANGLE (Degree)	RAW VALUE (dBuV)	CORRECTION FACTOR (dB/m)
1	*2457.00	105.60 PK			1.75 H	339	74.90	30.70
2	*2457.00	95.70 AV			1.75 H	339	65.00	30.70
3	2483.50	60.07 PK	74.00	-13.93	1.80 H	356	29.25	30.82
4	2483.50	45.63 AV	54.00	-8.37	1.80 H	356	14.81	30.82
5	4914.00	46.93 PK	74.00	-27.07	1.61 H	312	11.05	35.88
6	4914.00	35.14 AV	54.00	-18.86	1.61 H	312	-0.74	35.88
7	7371.00	52.23 PK	74.00	-21.77	1.41 H	273	9.49	42.74
8	7371.00	38.14 AV	54.00	-15.86	1.41 H	273	-4.60	42.74
ANTENNA POLARITY & TEST DISTANCE: VERTICAL AT 3 M								
NO.	FREQ. (MHz)	EMISSION LEVEL (dBuV/m)	LIMIT (dBuV/m)	MARGIN (dB)	ANTENNA HEIGHT (m)	TABLE ANGLE (Degree)	RAW VALUE (dBuV)	CORRECTION FACTOR (dB/m)
1	*2457.00	107.90 PK			1.05 V	104	77.20	30.70
2	*2457.00	98.90 AV			1.05 V	104	68.20	30.70
3	2483.50	66.06 PK	74.00	-7.94	1.00 V	146	35.24	30.82
4	2483.50	49.11 AV	54.00	-4.89	1.00 V	146	18.29	30.82
5	4914.00	47.37 PK	74.00	-26.63	1.24 V	131	11.49	35.88
6	4914.00	35.29 AV	54.00	-18.71	1.24 V	131	-0.59	35.88
7	7371.00	52.10 PK	74.00	-21.90	1.30 V	39	9.36	42.74
8	7371.00	38.01 AV	54.00	-15.99	1.30 V	39	-4.73	42.74

- REMARKS:**
1. Emission level (dBuV/m) = Raw Value (dBuV) + Correction Factor (dB/m).
 2. Correction Factor (dB/m) = Antenna Factor (dB/m) + Cable Factor (dB).
 3. The other emission levels were very low against the limit.
 4. Margin value = Emission level – Limit value.
 5. “ * “: Fundamental frequency.



A D T

EUT TEST CONDITION		MEASUREMENT DETAIL	
CHANNEL	Channel 11	FREQUENCY RANGE	1 ~ 25GHz
INPUT POWER	DC 3.9~4.2V from Battery	DETECTOR FUNCTION	Peak (PK) Average (AV)
ENVIRONMENTAL CONDITIONS	25deg. C, 66%RH 965hPa	TESTED BY	Eric Lee

ANTENNA POLARITY & TEST DISTANCE: HORIZONTAL AT 3 M								
NO.	FREQ. (MHz)	EMISSION LEVEL (dBuV/m)	LIMIT (dBuV/m)	MARGIN (dB)	ANTENNA HEIGHT (m)	TABLE ANGLE (Degree)	RAW VALUE (dBuV)	CORRECTION FACTOR (dB/m)
1	*2462.00	101.98 PK			1.69 H	347	71.26	30.72
2	*2462.00	93.48 AV			1.69 H	347	62.76	30.72
3	2483.50	57.84 PK	74.00	-16.16	1.15 H	71	27.02	30.82
4	2483.50	44.86 AV	54.00	-9.14	1.15 H	71	14.04	30.82
5	4924.00	43.84 PK	74.00	-30.16	1.36 H	198	7.94	35.90
6	4924.00	32.79 AV	54.00	-21.21	1.36 H	198	-3.11	35.90
7	7386.00	52.42 PK	74.00	-21.58	1.39 H	19	9.62	42.80
8	7386.00	38.58 AV	54.00	-15.42	1.39 H	19	-4.22	42.80
ANTENNA POLARITY & TEST DISTANCE: VERTICAL AT 3 M								
NO.	FREQ. (MHz)	EMISSION LEVEL (dBuV/m)	LIMIT (dBuV/m)	MARGIN (dB)	ANTENNA HEIGHT (m)	TABLE ANGLE (Degree)	RAW VALUE (dBuV)	CORRECTION FACTOR (dB/m)
1	*2462.00	106.11 PK			1.00 V	191	75.39	30.72
2	*2462.00	96.43 AV			1.00 V	191	65.71	30.72
3	2483.50	60.39 PK	74.00	-13.61	1.05 V	3	29.57	30.82
4	2483.50	45.81 AV	54.00	-8.19	1.05 V	3	14.99	30.82
5	4924.00	44.62 PK	74.00	-29.38	1.29 V	180	8.72	35.90
6	4924.00	32.58 AV	54.00	-21.42	1.29 V	180	-3.32	35.90
7	7386.00	51.29 PK	74.00	-22.71	1.33 V	60	8.49	42.80
8	7386.00	37.54 AV	54.00	-16.46	1.33 V	60	-5.26	42.80

- REMARKS:**
1. Emission level (dBuV/m) = Raw Value (dBuV) + Correction Factor (dB/m).
 2. Correction Factor (dB/m) = Antenna Factor (dB/m) + Cable Factor (dB).
 3. The other emission levels were very low against the limit.
 4. Margin value = Emission level – Limit value.
 5. “ * “: Fundamental frequency.



A D T

RESTRICTED BANDEDGE (802.11g MODE,CH 1, HORIZONTAL)

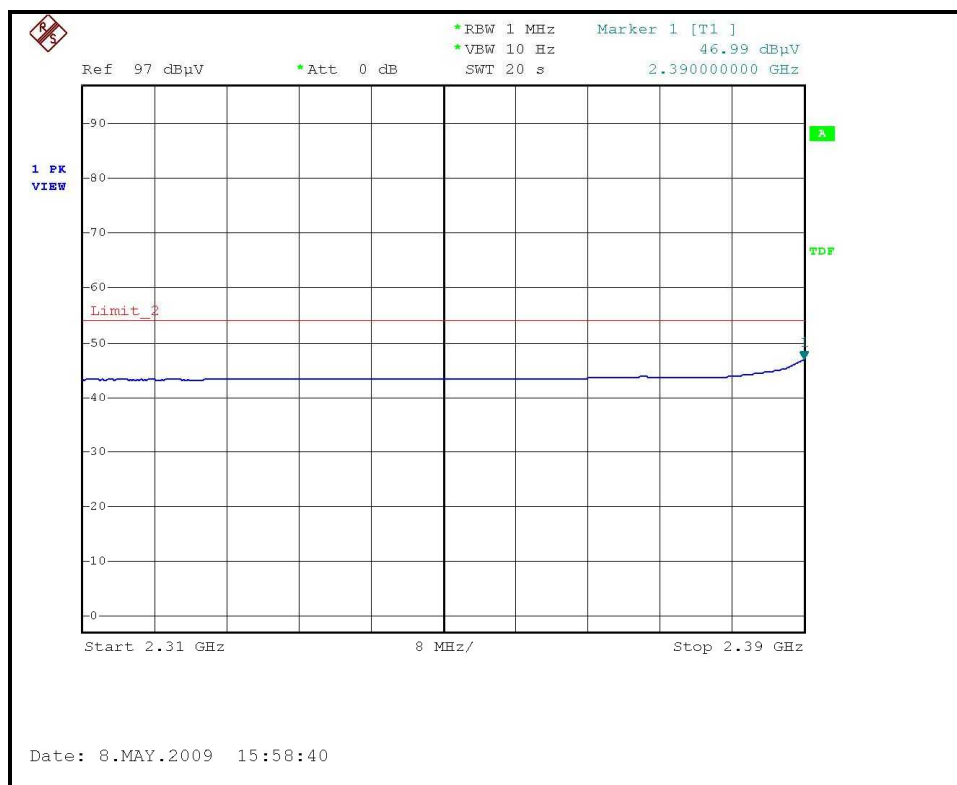
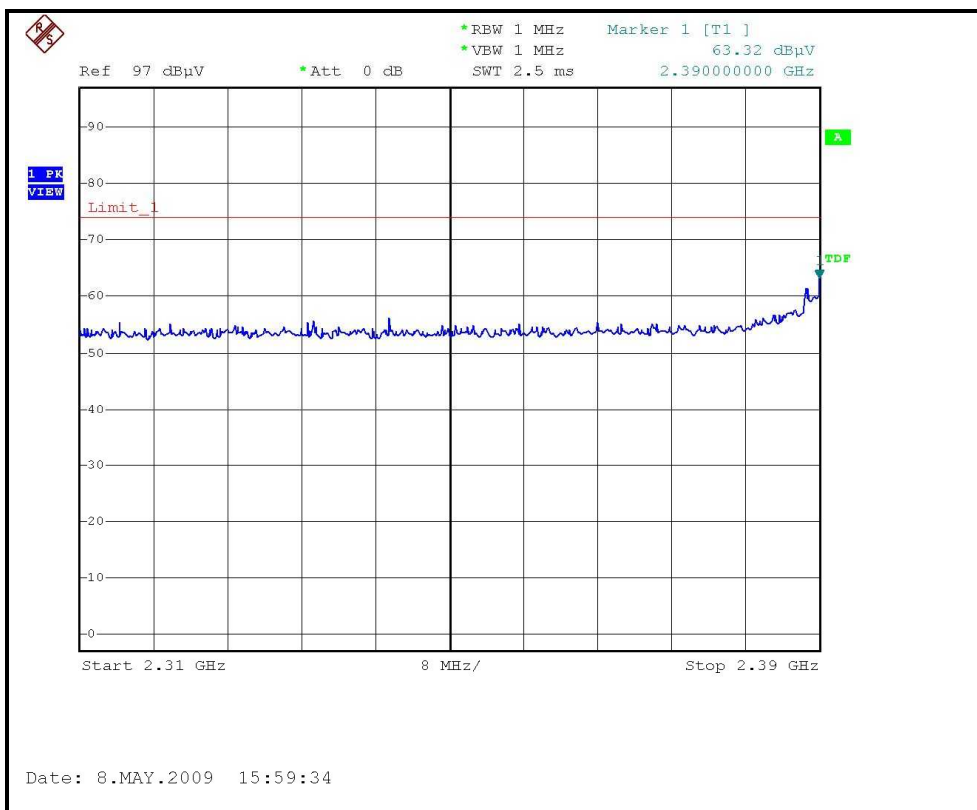



A D T

RESTRICTED BANDEDGE (802.11g MODE,CH 1, VERTICAL)

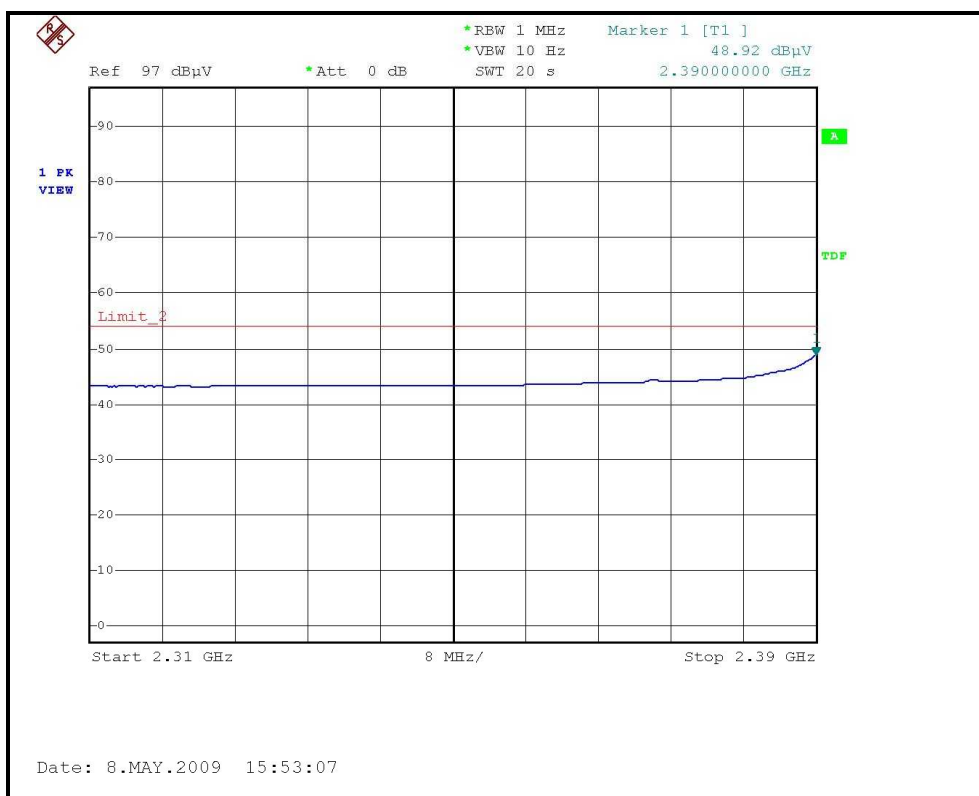
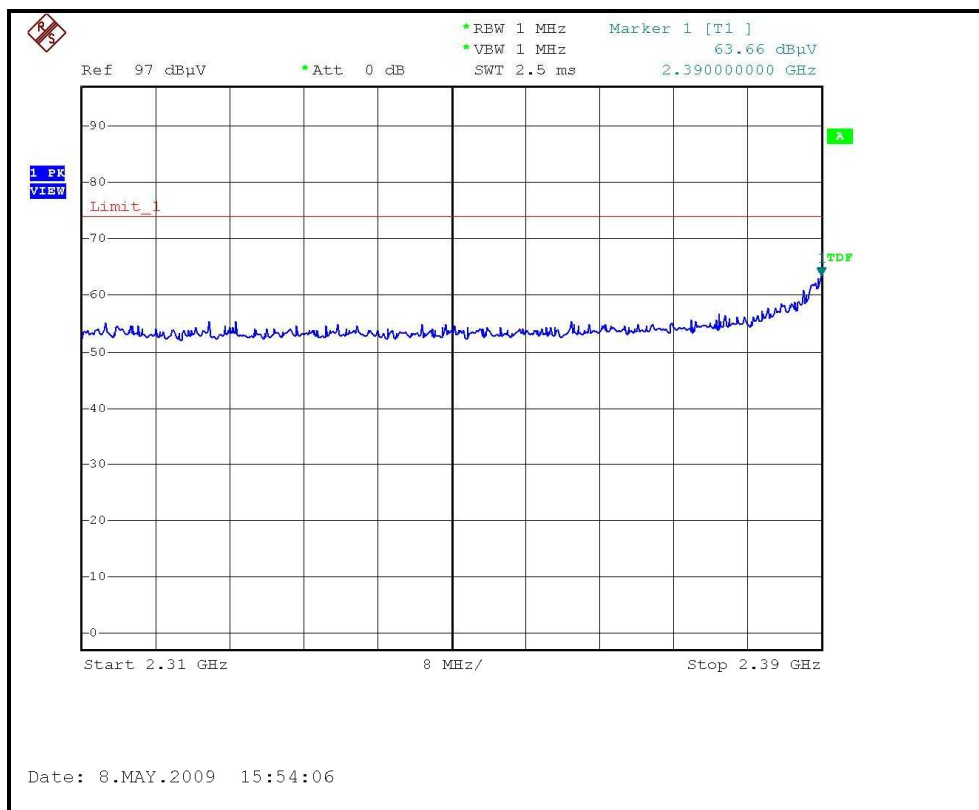



A D T

RESTRICTED BANDEDGE (802.11g MODE,CH 2, VERTICAL)

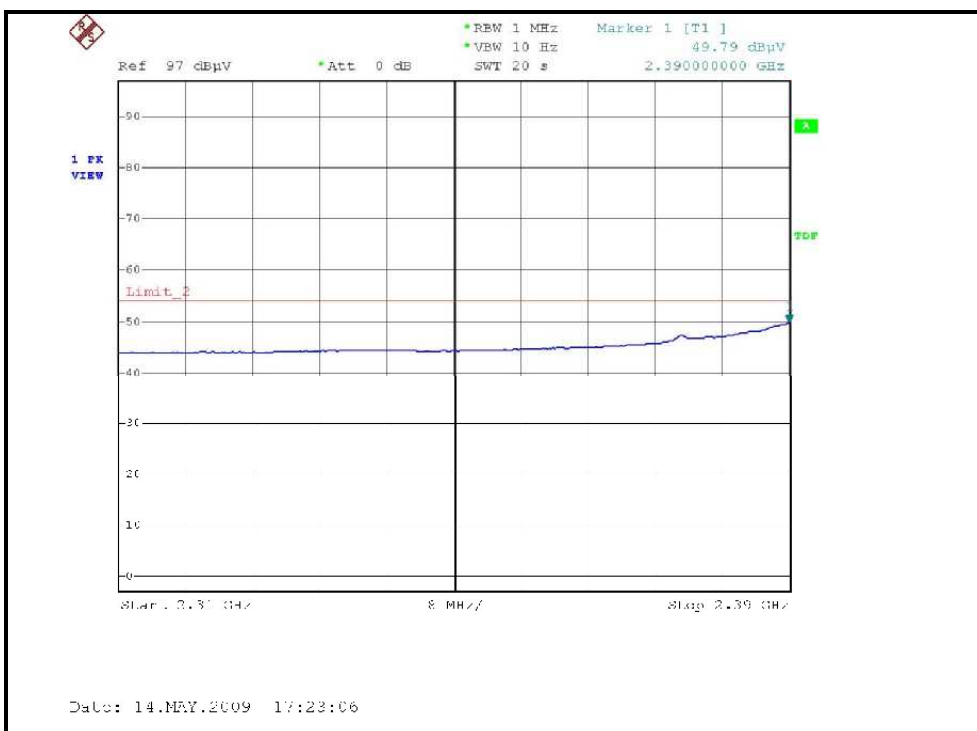
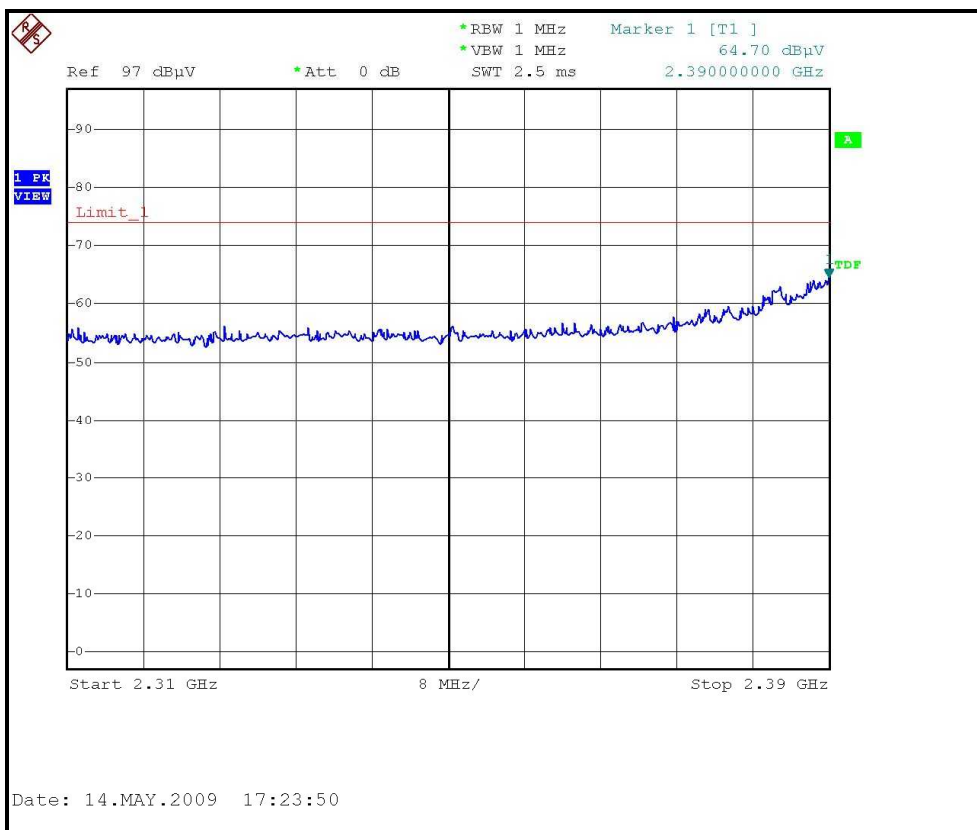



A D T

RESTRICTED BANDEDGE (802.11g MODE, CH 3, VERTICAL)

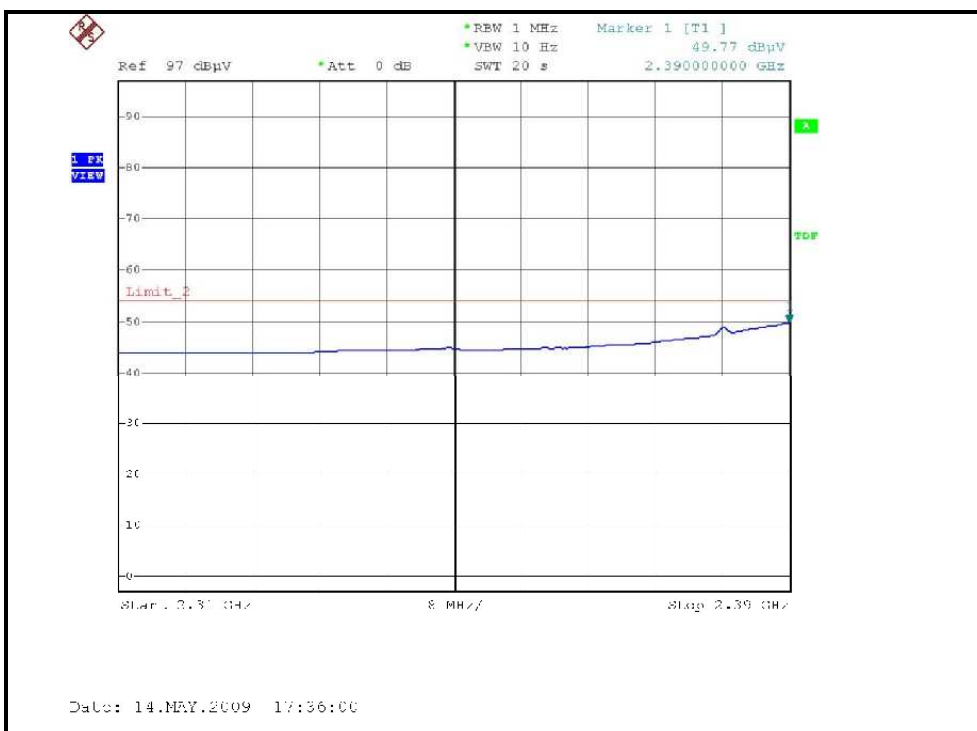
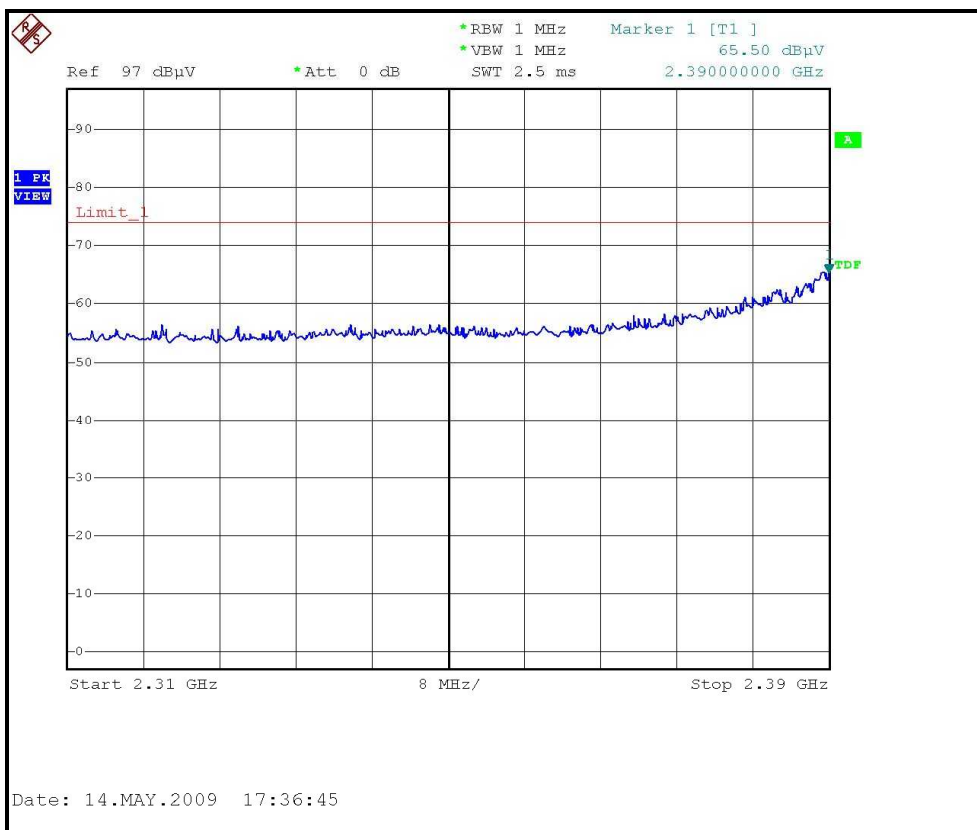



A D T

RESTRICTED BANDEDGE (802.11g MODE,CH 10, HORIZONTAL)

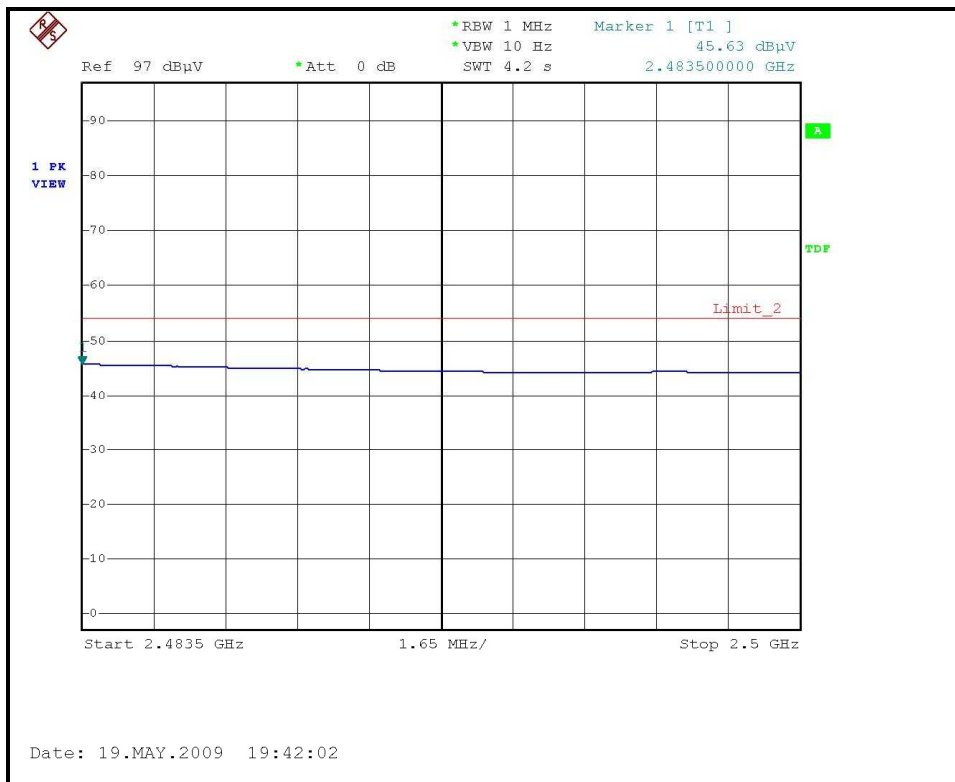
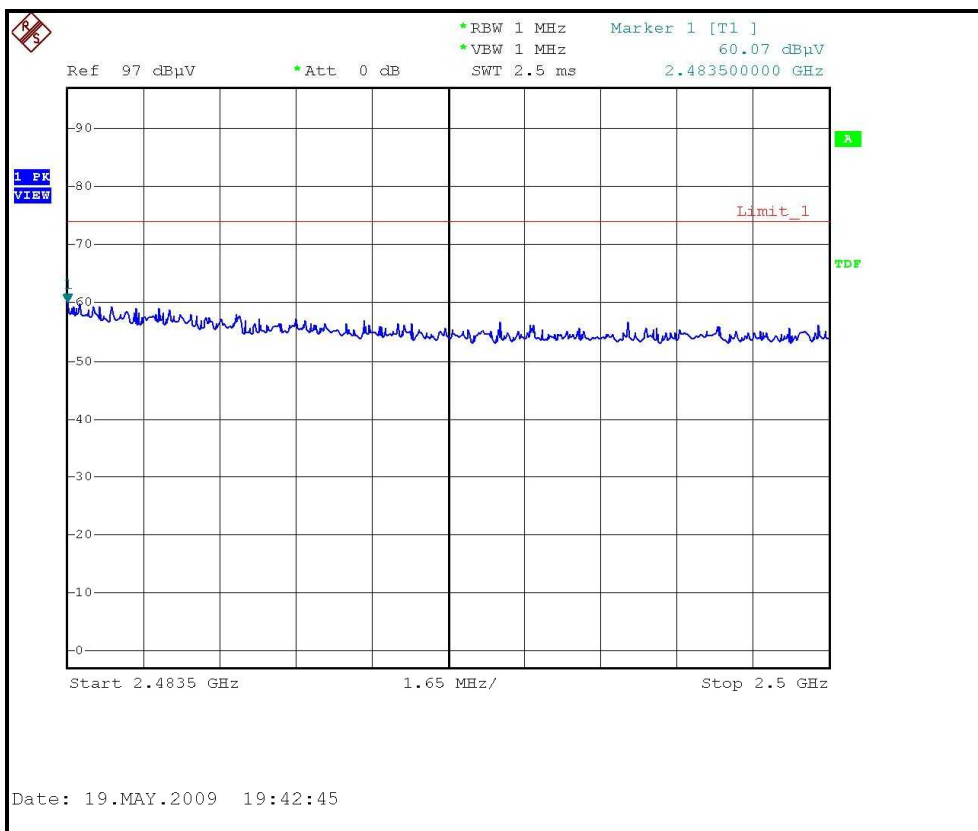



A D T

RESTRICTED BANDEDGE (802.11g MODE, CH 10, VERTICAL)

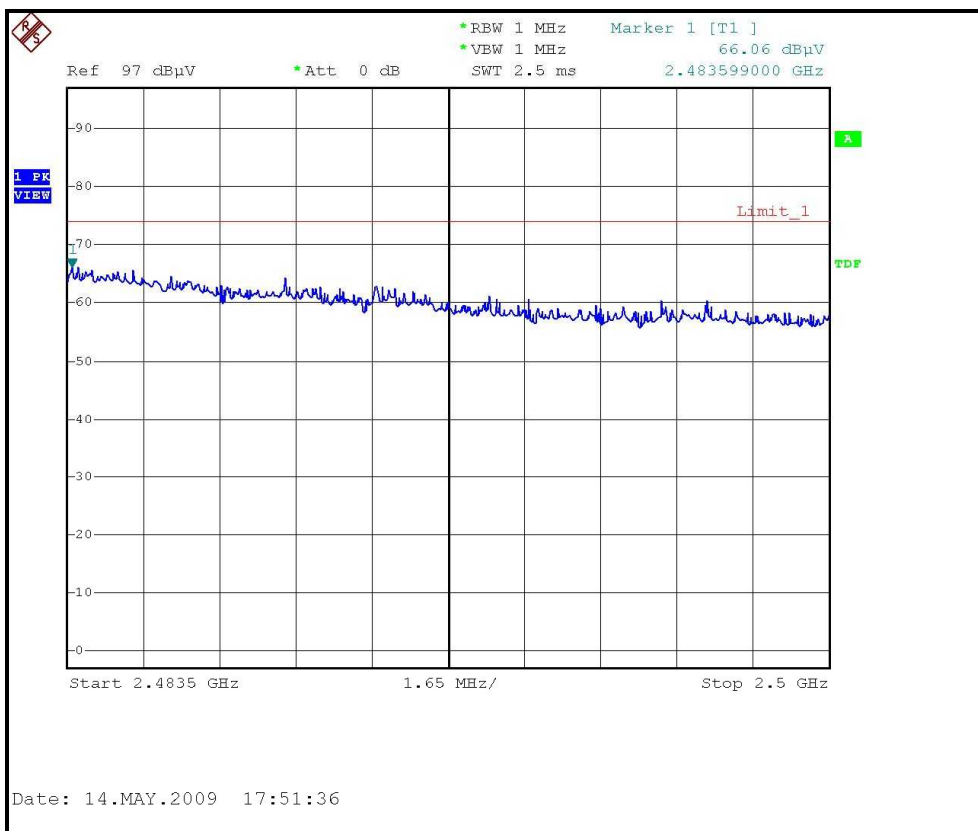



A D T

RESTRICTED BANDEDGE (802.11g MODE,CH 11, HORIZONTAL)

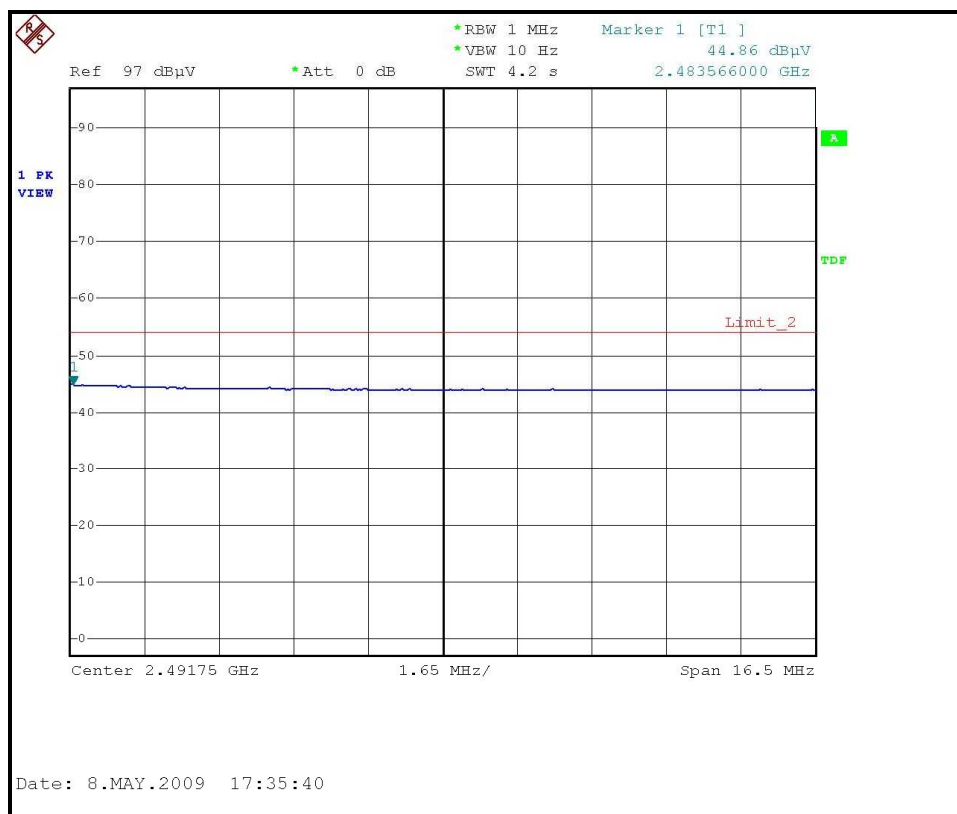
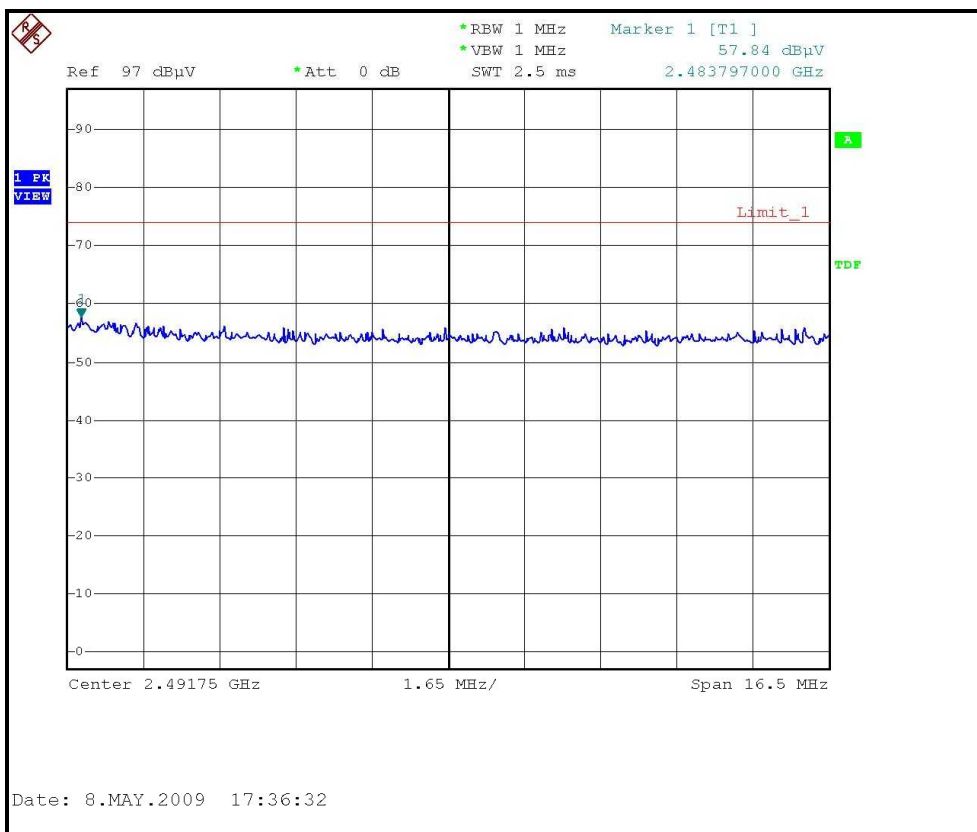



A D T

RESTRICTED BANDEDGE (802.11g MODE, CH 11, VERTICAL)

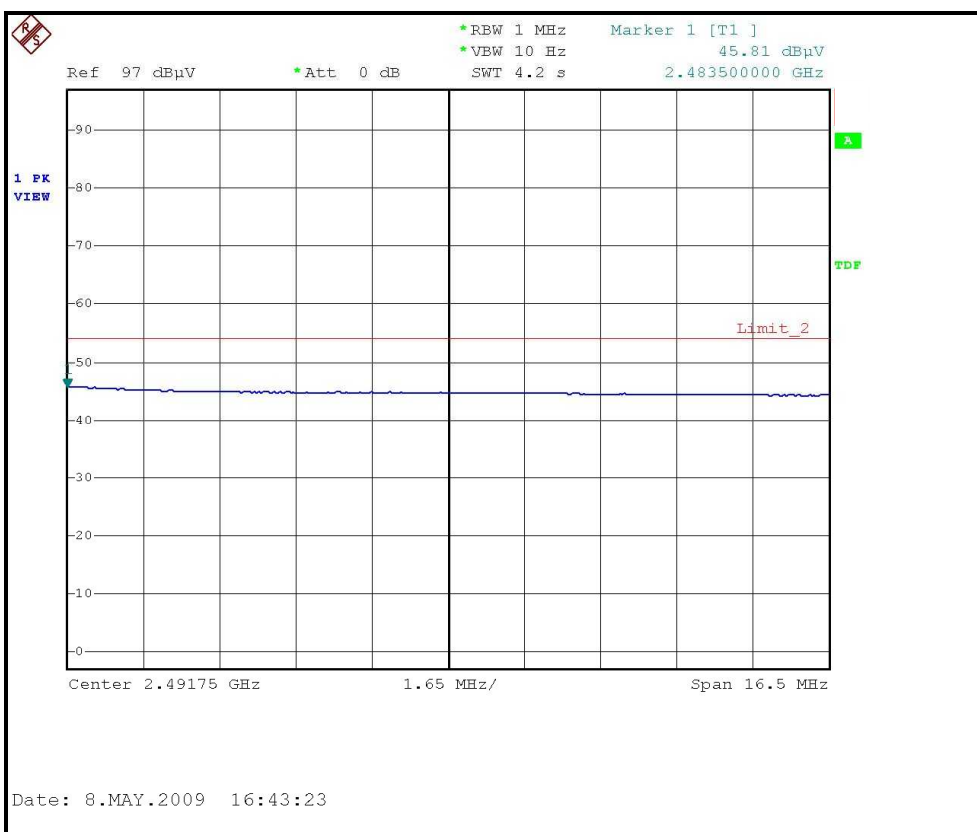
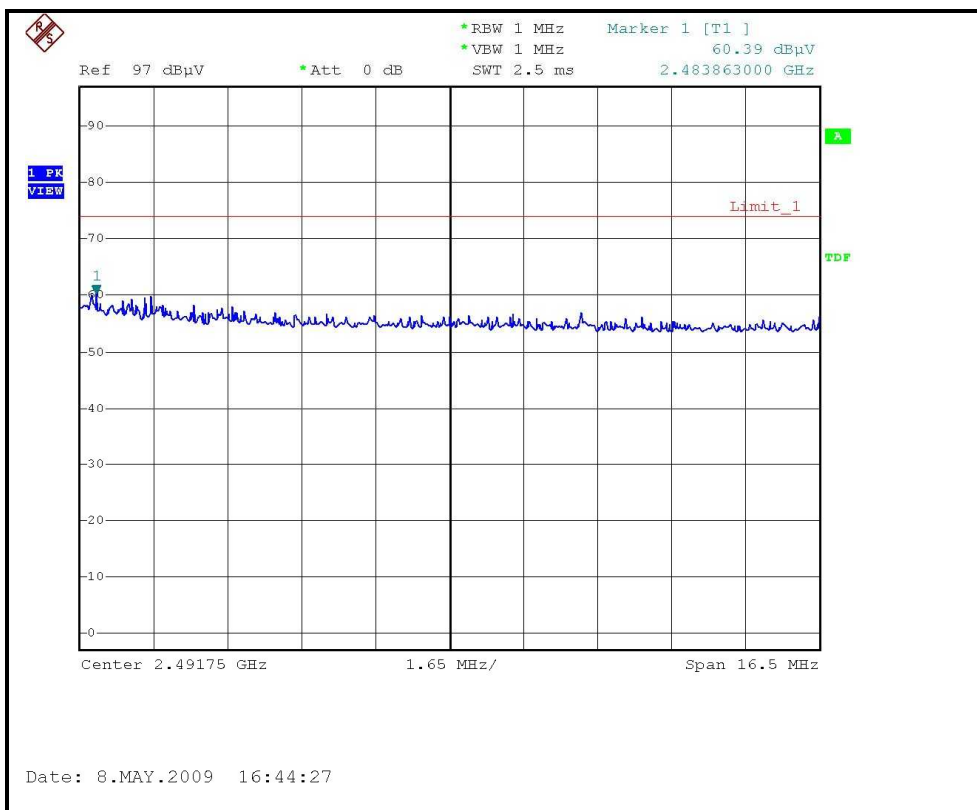



4.2 6dB BANDWIDTH MEASUREMENT

4.2.1 LIMITS OF 6dB BANDWIDTH MEASUREMENT

The minimum of 6dB Bandwidth Measurement is 0.5 MHz.

4.2.2 TEST INSTRUMENTS

Description & Manufacturer	Model No.	Serial No.	Calibrated DATE	Calibrated Until
R&S SPECTRUM ANALYZER	FSP40	100036	Dec. 09, 2008	Dec. 08, 2009

NOTE:

- 1.The calibration interval of the above test instruments is 12 months and the calibrations are traceable to NML/ROC and NIST/USA.

4.2.3 TEST PROCEDURE

The transmitter output was connected to the spectrum analyzer through an attenuator. The bandwidth of the fundamental frequency was measured by spectrum analyzer with 100kHz RBW and 100kHz VBW. The 6dB bandwidth is defined as the total spectrum the power of which is higher than peak power minus 6dB.

4.2.4 DEVIATION FROM TEST STANDARD

No deviation

4.2.5 TEST SETUP



4.2.6 EUT OPERATING CONDITIONS

The software provided by client to enable the EUT under transmission condition continuously at lowest, middle and highest channel frequencies individually.



A D T

4.2.7 TEST RESULTS

802.11b DSSS MODULATION:

MODULATION TYPE	DBPSK	TRANSFER RATE	1Mbps
INPUT POWER	DC 3.9~4.2V from Battery	ENVIRONMENTAL CONDITIONS	25deg.C, 60%RH, 965hPa
TESTED BY	Frank Liu		

CHANNEL	CHANNEL FREQUENCY (MHz)	6dB BANDWIDTH (MHz)	MINIMUM LIMIT (MHz)	PASS / FAIL
1	2412	11.55	0.5	PASS
6	2437	11.60	0.5	PASS
11	2462	11.58	0.5	PASS

CH1

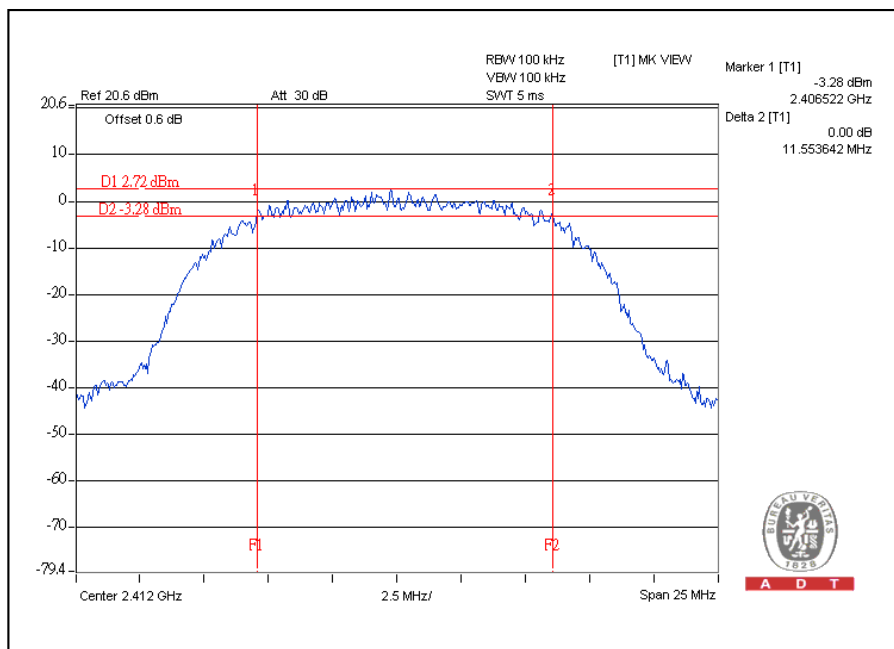



A D T

CH6

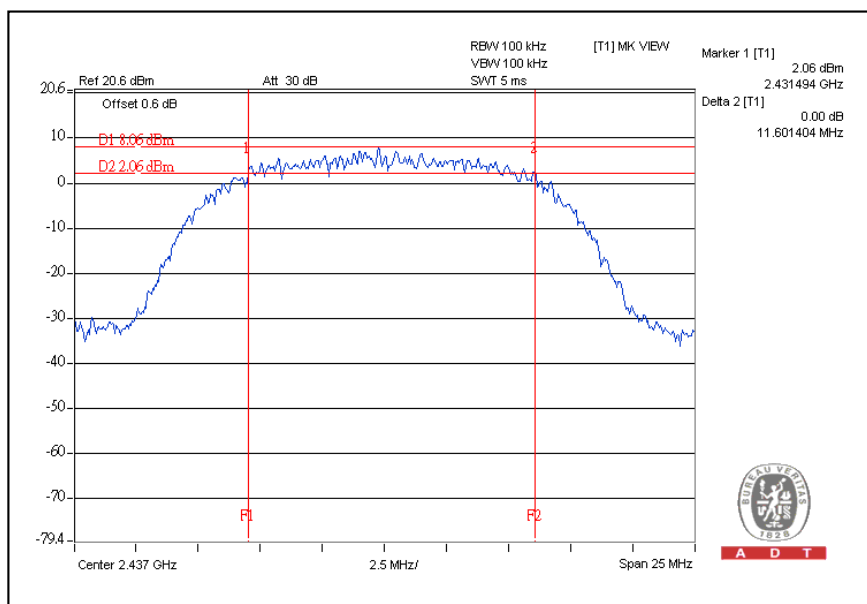

CH11

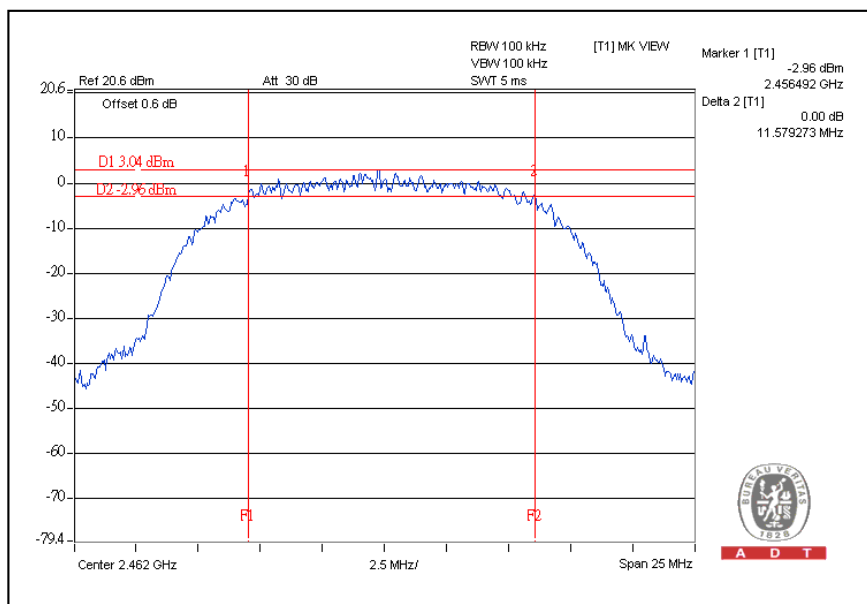



A D T

802.11g OFDM MODULATION:

MODULATION TYPE	BPSK	TRANSFER RATE	6Mbps
INPUT POWER	DC 3.9~4.2V from Battery	ENVIRONMENTAL CONDITIONS	25deg.C, 60%RH, 965hPa
TESTED BY	Frank Liu		

CHANNEL	CHANNEL FREQUENCY (MHz)	6dB BANDWIDTH (MHz)	MINIMUM LIMIT (MHz)	PASS / FAIL
1	2412	16.12	0.5	PASS
6	2437	16.33	0.5	PASS
11	2462	16.36	0.5	PASS

CH1

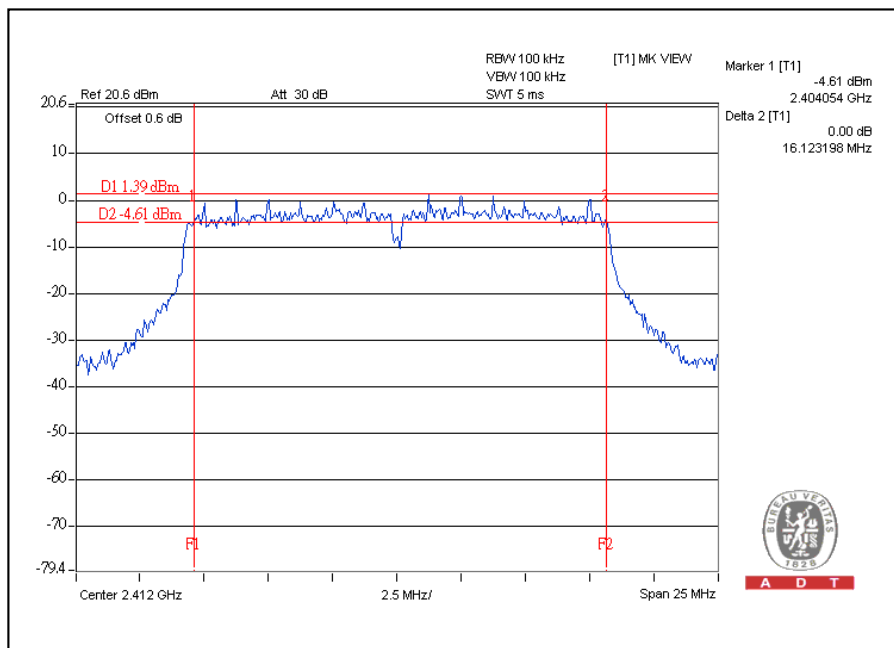



A D T

CH6

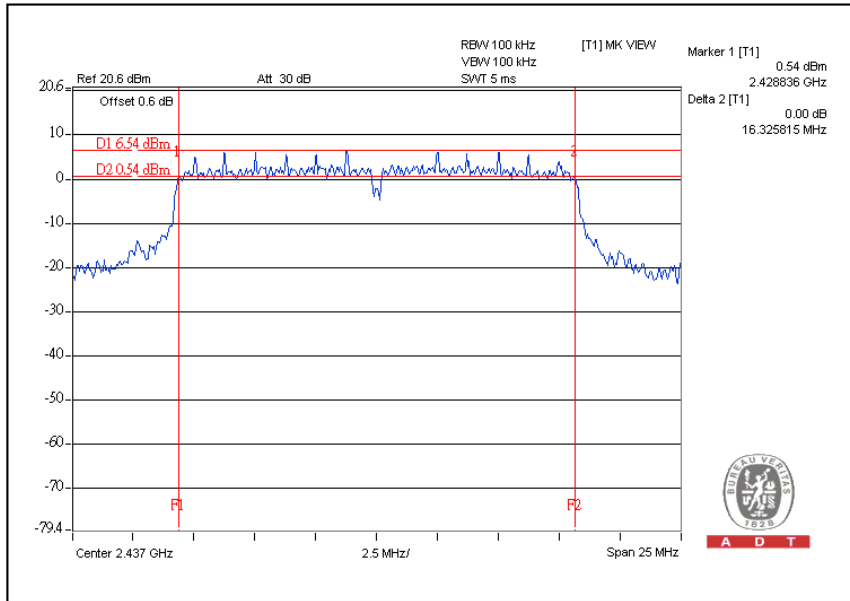

CH11

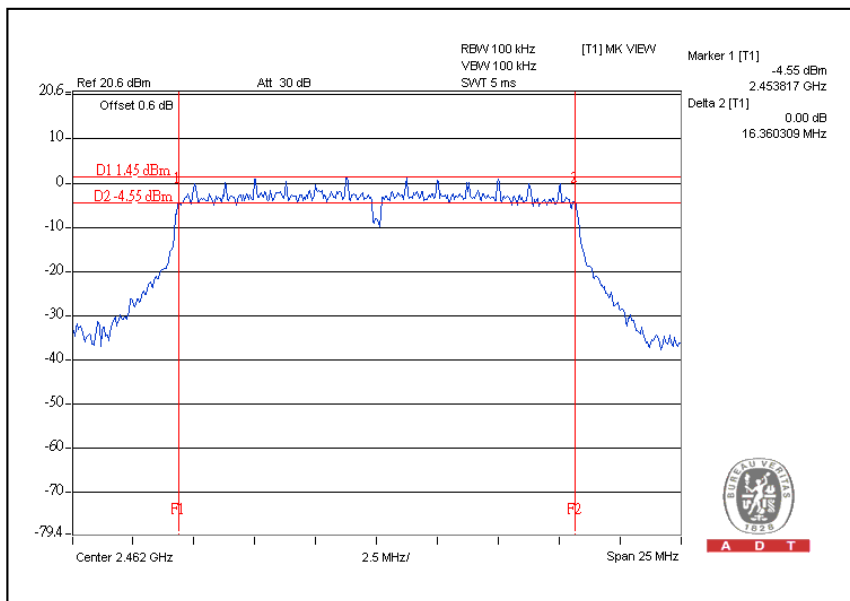

4.3 MAXIMUM PEAK OUTPUT POWER

4.3.1 LIMITS OF MAXIMUM PEAK OUTPUT POWER MEASUREMENT

The Maximum Peak Output Power Measurement is 30dBm.

4.3.2 INSTRUMENTS

Description & Manufacturer	Model no.	Serial No.	Calibrated date	Calibrated Until
Anritsu Power Meter	ML2495A	0824006	June 14, 2008	June 13, 2009
Pulse Power Sensor	MA2411B	0738172	April 25, 2009	April 24, 2010

NOTE:

The calibration interval of the above test instruments is 12 months and the calibrations are traceable to NML/ROC and NIST/USA.

4.3.3 TEST PROCEDURES

1. The transmitter output was connected to the power meter through an attenuator; the bandwidth of the fundamental frequency was measured with the power meter.
2. Record the power level.

4.3.4 DEVIATION FROM TEST STANDARD

No deviation

4.3.5 TEST SETUP

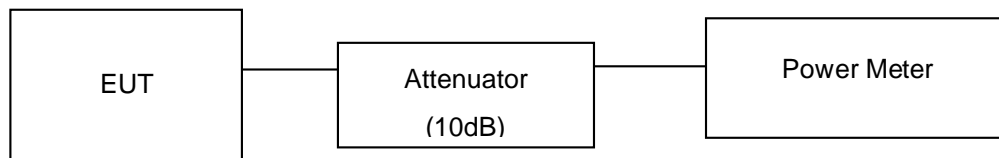

4.3.6 EUT OPERATING CONDITIONS

Same as Item 4.2.6



4.3.7 TEST RESULTS

802.11b DSSS MODULATION:

MODULATION TYPE	DBPSK	TRANSFER RATE	1Mbps
INPUT POWER	DC 3.9~4.2V from Battery	ENVIRONMENTAL CONDITIONS	25deg.C, 60%RH, 965hPa
TESTED BY	Frank Liu		

CHANNEL	CHANNEL FREQUENCY (MHz)	PEAK POWER OUTPUT (mW)	PEAK POWER OUTPUT (dBm)	PEAK POWER LIMIT (dBm)	PASS / FAIL
1	2412	37.068	15.69	30	PASS
6	2437	116.681	20.67	30	PASS
11	2462	37.325	15.72	30	PASS

802.11g OFDM MODULATION:

MODULATION TYPE	BPSK	TRANSFER RATE	6Mbps
INPUT POWER	DC 3.9~4.2V from Battery	ENVIRONMENTAL CONDITIONS	25deg.C, 60%RH, 965hPa
TESTED BY	Frank Liu		

CHANNEL	CHANNEL FREQUENCY (MHz)	PEAK POWER OUTPUT (mW)	PEAK POWER OUTPUT (dBm)	PEAK POWER LIMIT (dBm)	PASS / FAIL
1	2412	169.824	22.30	30	PASS
6	2437	249.459	23.97	30	PASS
11	2462	187.499	22.73	30	PASS



A D T

4.4 POWER SPECTRAL DENSITY MEASUREMENT

4.4.1 LIMITS OF POWER SPECTRAL DENSITY MEASUREMENT

The Maximum of Power Spectral Density Measurement is 8dBm.

4.4.2 TEST INSTRUMENTS

Description & Manufacturer	Model No.	Serial No.	Calibrated DATE	Calibrated Until
R&S SPECTRUM ANALYZER	FSP40	100036	Dec. 09, 2008	Dec. 08, 2009

NOTE:

- 1.The calibration interval of the above test instruments is 12 months and the calibrations are traceable to NML/ROC and NIST/USA.

4.4.3 TEST PROCEDURE

The transmitter output was connected to the spectrum analyzer through an attenuator, the bandwidth of the fundamental frequency was measured with the spectrum analyzer using 3kHz RBW and 30kHz VBW, set sweep time = span/3kHz. The power spectral density was measured and recorded. The sweep time is allowed to be longer than span/3kHz for a full response of the mixer in the spectrum analyzer.

4.4.4 DEVIATION FROM TEST STANDARD

No deviation

4.4.5 TEST SETUP

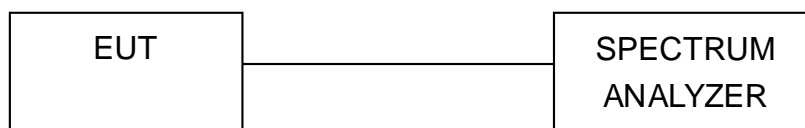

4.4.6 EUT OPERATING CONDITION

Same as Item 4.2.6



A D T

4.4.7 TEST RESULTS

802.11b DSSS MODULATION:

MODULATION TYPE	DBPSK	TRANSFER RATE	1Mbps
INPUT POWER	DC 3.9~4.2V from Battery	ENVIRONMENTAL CONDITIONS	25deg.C, 60%RH, 965hPa
TESTED BY	Frank Liu		

CHANNEL	CHANNEL FREQUENCY (MHz)	RF POWER LEVEL IN 3kHz BW (dBm)	MAXIMUM LIMIT (dBm)	PASS / FAIL
1	2412	-11.15	8	PASS
6	2437	-5.93	8	PASS
11	2462	-10.73	8	PASS

CH1

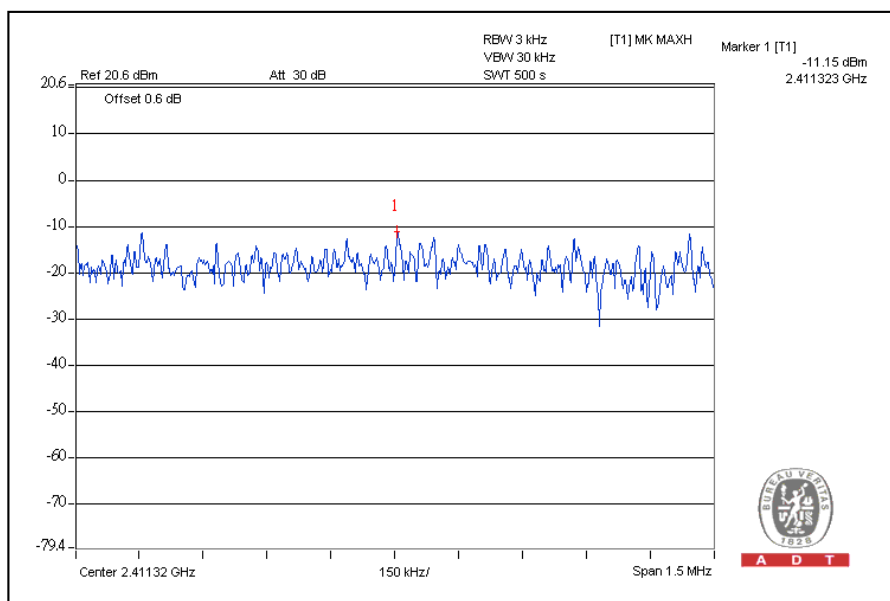



A D T

CH6

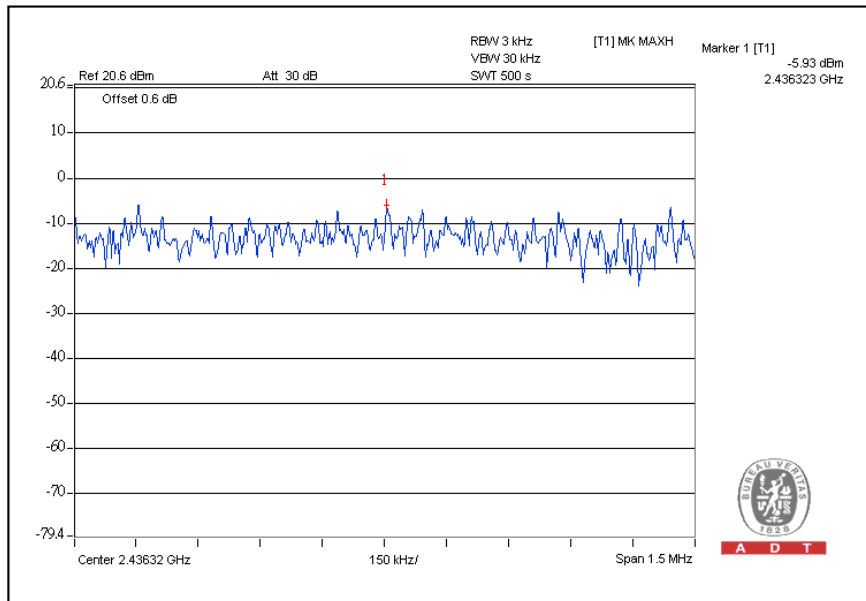

CH11

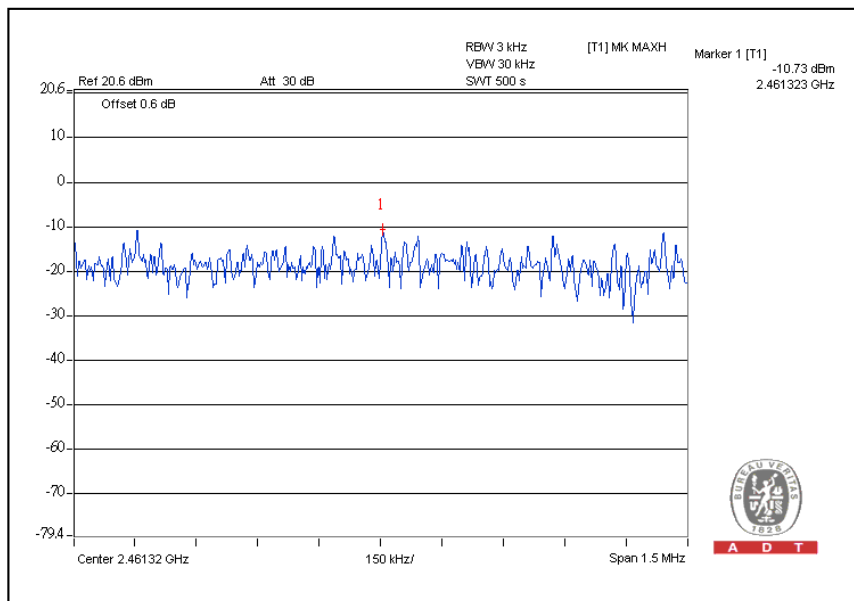



A D T

802.11g OFDM MODULATION:

MODULATION TYPE	BPSK	TRANSFER RATE	6Mbps
INPUT POWER	DC 3.9~4.2V from Battery	ENVIRONMENTAL CONDITIONS	25deg.C, 60%RH, 965hPa
TESTED BY	Frank Liu		

CHANNEL	CHANNEL FREQUENCY (MHz)	RF POWER LEVEL IN 3kHz BW (dBm)	MAXIMUM LIMIT (dBm)	PASS / FAIL
1	2412	-15.08	8	PASS
6	2437	-9.73	8	PASS
11	2462	-14.74	8	PASS

CH1

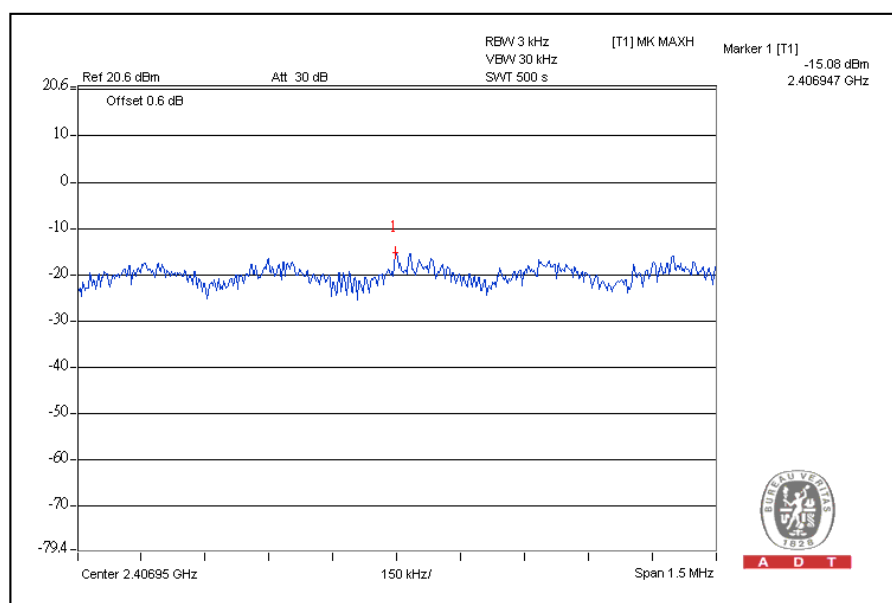



A D T

CH6

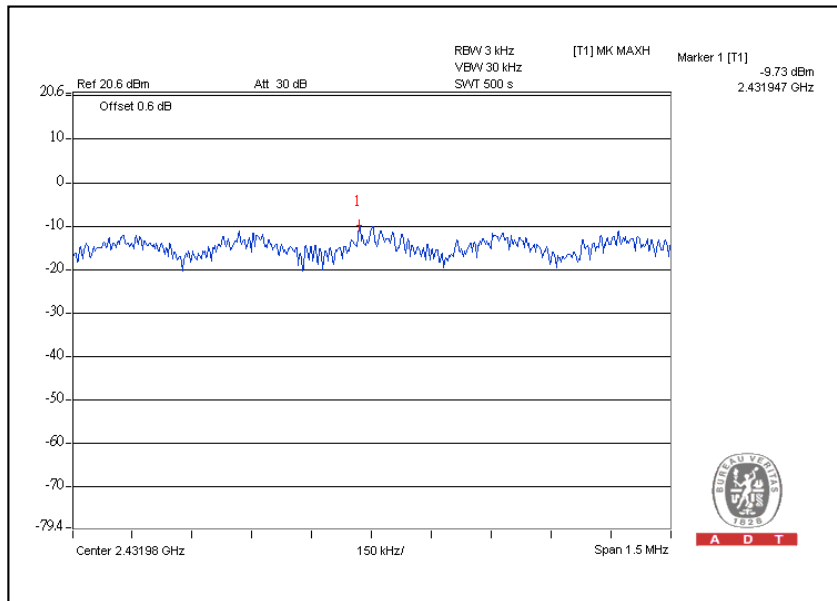

CH11

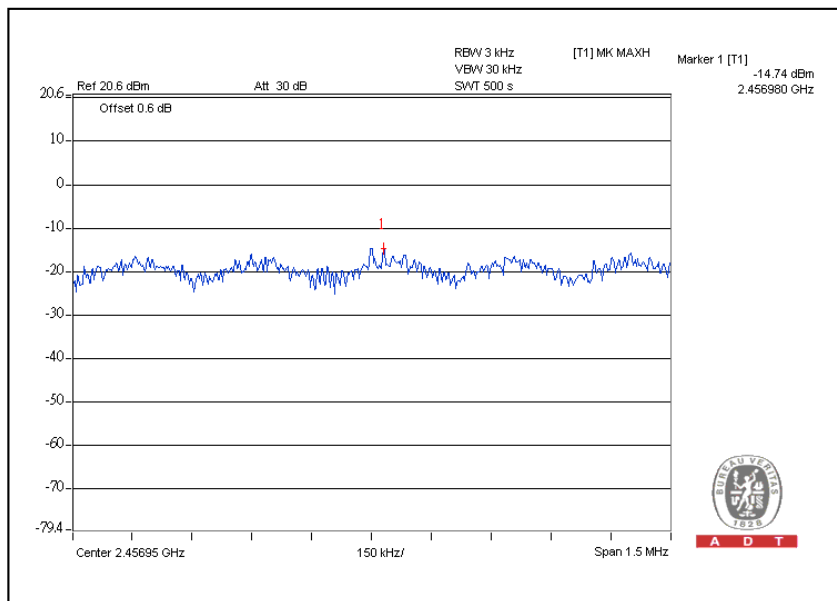



A D T

4.5 CONDUCTED OUT-BAND EMISSION MEASUREMENT

4.5.1 LIMITS OF CONDUCTED OUT-BAND EMISSION MEASUREMENT

Below -20dB of the highest emission level of operating band (in 100kHz Resolution Bandwidth).

4.5.2 TEST INSTRUMENTS

Description & Manufacturer	Model No.	Serial No.	Calibrated DATE	Calibrated Until
R&S SPECTRUM ANALYZER	FSP40	100036	Dec. 09, 2008	Dec. 08, 2009

NOTE:

1. The calibration interval of the above test instruments is 12 months and the calibrations are traceable to NML/ROC and NIST/USA.

4.5.3 TEST PROCEDURE

The transmitter output was connected to the spectrum analyzer via a low loss cable. Set both RBW of spectrum analyzer to 100kHz and VBW of spectrum analyzer to 300kHz with suitable frequency span including 100 MHz bandwidth from band edge. The conducted out-band emission was measured and recorded.

The spectrum plots (RBW = 100kHz, VBW = 300kHz) are attached on the following pages.



A D T

4.5.4 DEVIATION FROM TEST STANDARD

No deviation

4.5.5 EUT OPERATING CONDITION

Same as Item 4.2.6

4.5.6 TEST RESULTS

The spectrum plots are attached on the following below images. D1 line indicates the highest level, and D2 line indicates the 20dB offset below D1. It shows compliance with the requirement in part 15.247(d).

802.11b DSSS MODULATION:

CH1

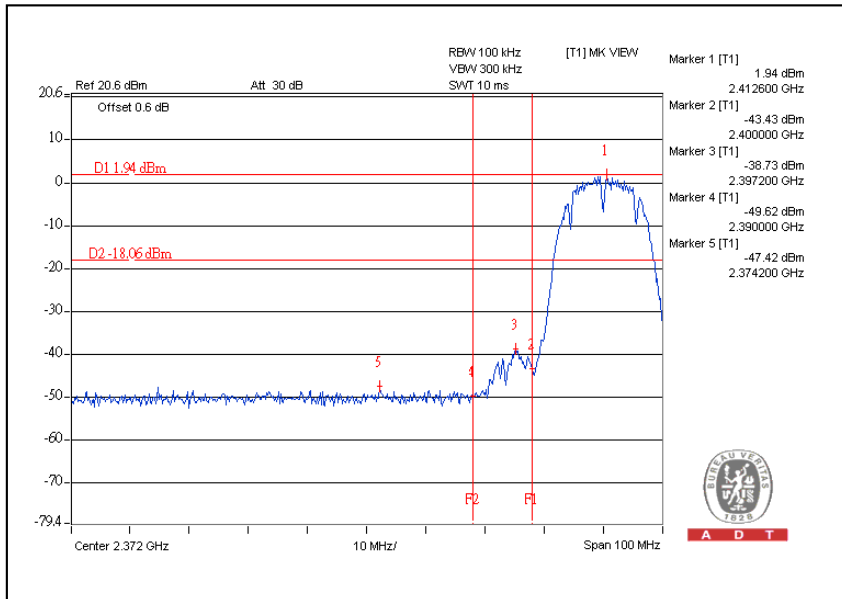

CH11

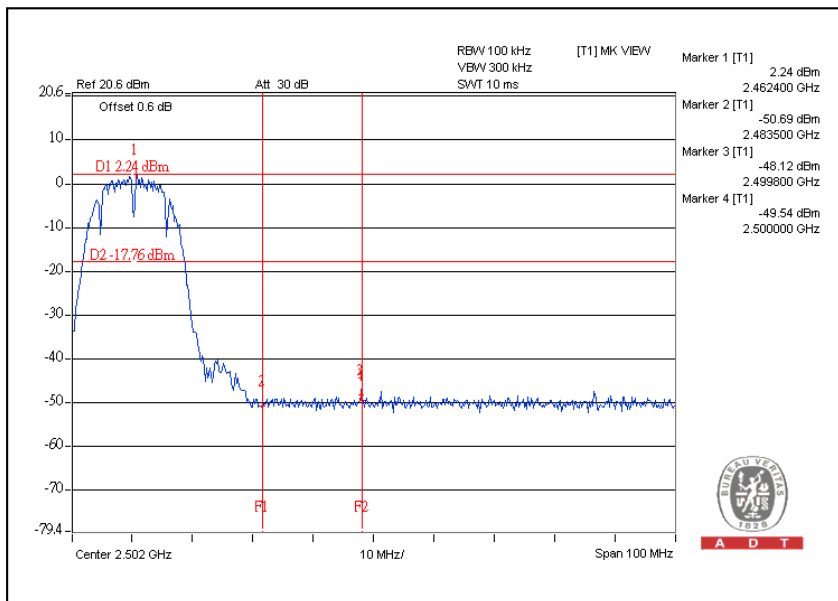



A D T

CH1

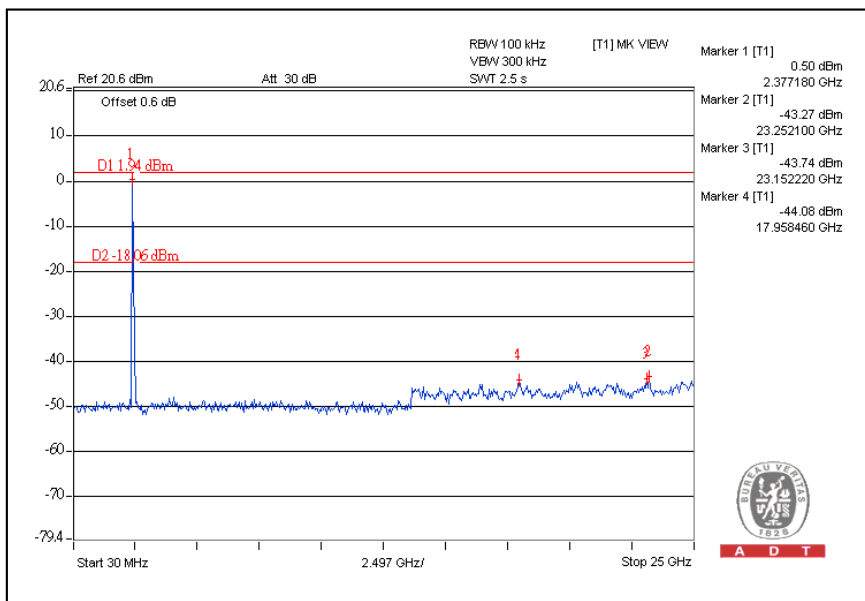

CH11

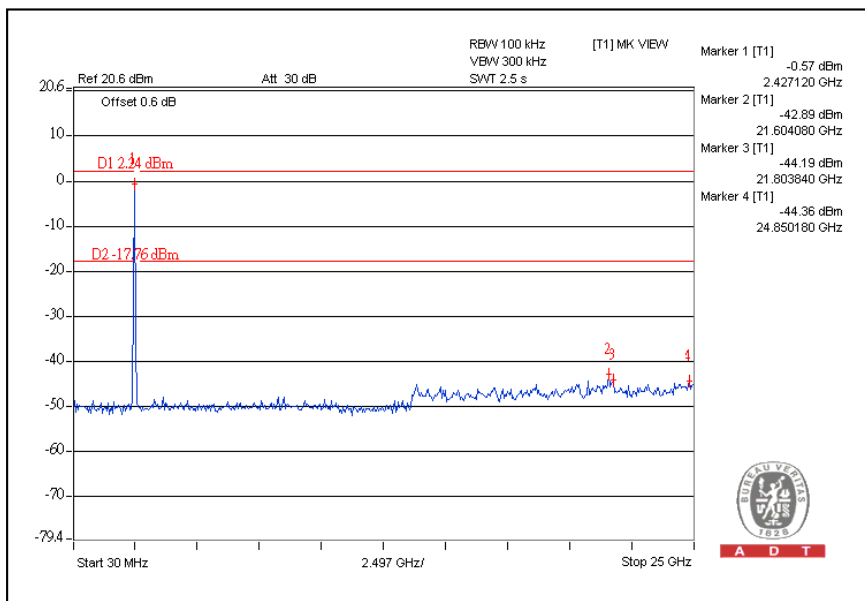

802.11g OFDM MODULATION:

CH 1

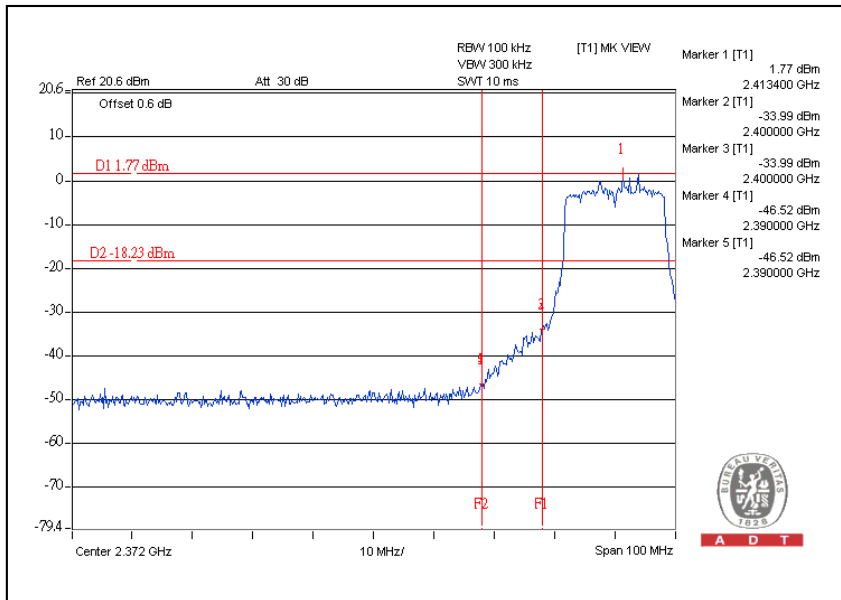

CH11

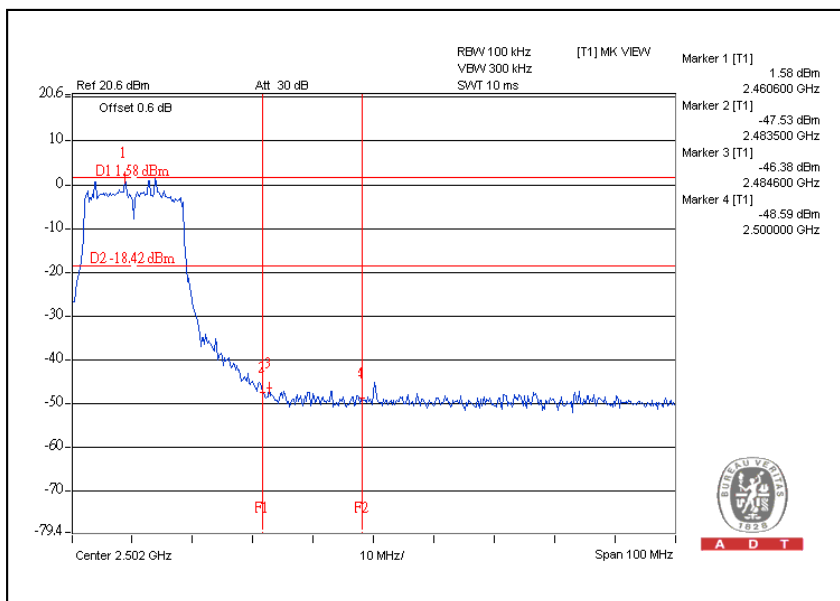



A D T

CH1

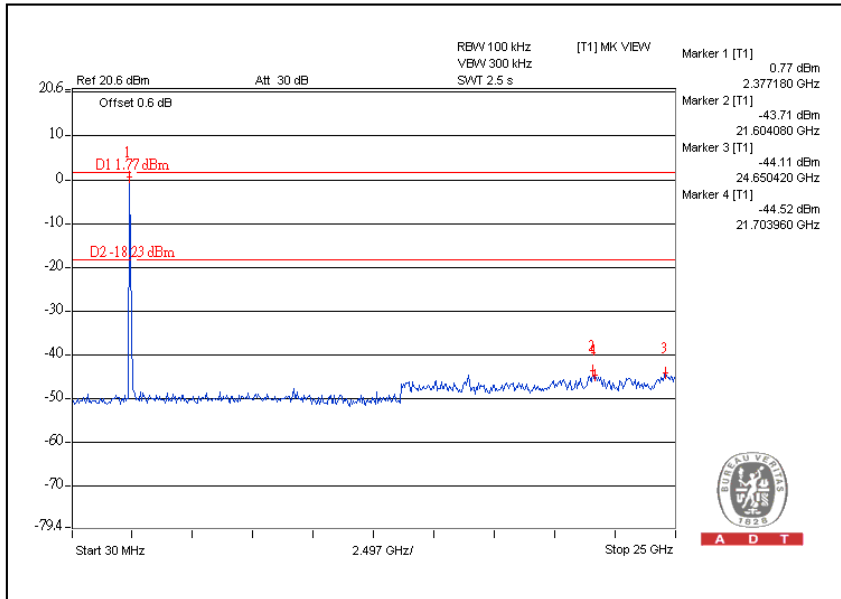

A D T

CH11



A D T

4.6 ANTENNA REQUIREMENT

4.6.1 STANDARD APPLICABLE

For intentional device, according to FCC 47 CFR Section 15.203, an intentional radiator shall be designed to ensure that no antenna other than that furnished by the responsible party shall be used with the device. And according to FCC 47 CFR Section 15.247 (b), if transmitting antennas of directional gain greater than 6dBi are used, the power shall be reduced by the amount in dB that the directional gain of the antenna exceeds 6dBi.

4.6.2 ANTENNA CONNECTED CONSTRUCTION

The antenna used in this product is PIFA antenna without connector. The maximum Gain of the antenna is -3.5 dBi.



A D T

5. INFORMATION ON THE TESTING LABORATORIES

We, Bureau Veritas Consumer Products Services (H.K.) Ltd., Taoyuan Branch, were founded in 1988 to provide our best service in EMC, Radio, Telecom and Safety consultation. Our laboratories are accredited and approved by the following approval agencies according to ISO/IEC 17025.

USA	FCC, NVLAP
Germany	TUV Rheinland
Japan	VCCI
Norway	NEMKO
Canada	INDUSTRY CANADA, CSA
R.O.C.	TAF, BSMI, NCC
Netherlands	Telefication
Singapore	GOST-ASIA(MOU)
Russia	CERTIS(MOU)

Copies of accreditation certificates of our laboratories obtained from approval agencies can be downloaded from our web site:

www.adt.com.tw/index.5/phtml. If you have any comments, please feel free to contact us at the following:

Linko EMC/RF Lab:

Tel: 886-2-26052180
Fax: 886-2-26052943

Hsin Chu EMC/RF Lab:

Tel: 886-3-5935343
Fax: 886-3-5935342

Hwa Ya EMC/RF/Safety Telecom Lab:

Tel: 886-3-3183232
Fax: 886-3-3185050

Web Site: www.adt.com.tw

The address and road map of all our labs can be found in our web site also



A D T

6. APPENDIX A - MODIFICATIONS RECORDERS FOR ENGINEERING CHANGES TO THE EUT BY THE LAB

No any modifications are made to the EUT by the lab during the test.

--- END ---