



SAR TEST REPORT

REPORT NO.: SA980507H07

MODEL NO.: CA1060

RECEIVED: May 07, 2009

TESTED: May 20, 2009

ISSUED: May 25, 2009

APPLICANT: Motorola Inc.

ADDRESS: One Motorola Plaza Holtville, NY 11742

ISSUED BY: Bureau Veritas Consumer Products Services
(H.K.) Ltd., Taoyuan Branch

LAB ADDRESS: No. 47, 14th Ling, Chia Pau Tsuen, Lin Kou
Hsiang, Taipei Hsien 244, Taiwan, R.O.C.

TEST LOCATION: No. 19, Hwa Ya 2nd Rd, Wen Hwa Tsuen, Kwei
Shan Hsiang, Taoyuan Hsien 333, Taiwan, R.O.C.

This test report consists of 37 pages in total except Appendix. It may be duplicated completely for legal use with the approval of the applicant. It should not be reproduced except in full, without the written approval of our laboratory. The client should not use it to claim product endorsement by TAF or any government agencies. The test results in the report only apply to the tested sample.





A D T

TABLE OF CONTENTS

1.	CERTIFICATION.....	3
2.	GENERAL INFORMATION.....	4
2.1	GENERAL DESCRIPTION OF EUT.....	4
2.2	GENERAL DESCRIPTION OF APPLIED STANDARDS.....	5
2.3	GENERAL INFORMATION OF THE SAR SYSTEM.....	6
2.4	GENERAL DESCRIPTION OF THE SPATIAL PEAK SAR EVALUATION.....	9
3.	DESCRIPTION OF SUPPORT UNITS.....	12
4.	DESCRIPTION OF TEST MODES AND CONFIGURATIONS.....	13
4.1.	DESCRIPTION OF ANTENNA LOCATION.....	13
4.2.	DESCRIPTION OF ASSESSMENT POSITION.....	14
4.3.	DESCRIPTION OF TEST MODE.....	15
4.4.	SUMMARY OF TEST RESULTS.....	16
4.5.	ENHANCED ENERGY COUPLING AT INCREASED SEPARATION DISTANCES.....	16
5.	TEST RESULTS.....	17
5.1	TEST PROCEDURES.....	17
5.2	MEASURED SAR RESULTS.....	19
5.3	SAR LIMITS.....	20
5.4	RECIPES FOR TISSUE SIMULATING LIQUIDS.....	21
5.5	TEST EQUIPMENT FOR TISSUE PROPERTY.....	24
6.	SYSTEM VALIDATION.....	25
6.1	TEST EQUIPMENT.....	25
6.2	TEST PROCEDURE.....	26
6.3	VALIDATION RESULTS.....	28
6.4	SYSTEM VALIDATION UNCERTAINTIES.....	29
7.	MEASUREMENT SAR PROCEDURE UNCERTAINTIES.....	30
7.1.	PROBE CALIBRATION UNCERTAINTY.....	30
7.2.	ISOTROPY UNCERTAINTY.....	31
7.3.	BOUNDARY EFFECT UNCERTAINTY.....	31
7.4.	PROBE LINEARITY UNCERTAINTY.....	32
7.5.	READOUT ELECTRONICS UNCERTAINTY.....	32
7.6.	RESPONSE TIME UNCERTAINTY.....	32
7.7.	INTEGRATION TIME UNCERTAINTY.....	33
7.8.	PROBE POSITIONER MECHANICAL TOLERANCE.....	34
7.9.	PROBE POSITIONING.....	34
7.10.	PHANTOM UNCERTAINTY.....	35
7.11.	DASY5 UNCERTAINTY BUDGET.....	36
8.	INFORMATION ON THE TESTING LABORATORIES.....	37
	APPENDIX A: TEST CONFIGURATIONS AND TEST DATA	
	APPENDIX B: ADT SAR MEASUREMENT SYSTEM	
	APPENDIX C: PHOTOGRAPHS OF SYSTEM VALIDATION	
	APPENDIX D: SYSTEM CERTIFICATE & CALIBRATION	



1. CERTIFICATION

PRODUCT: WiFi Voice Communication Appliance
MODEL: CA1060
BRAND: MOTOROLA
APPLICANT: Motorola Inc.
TESTED: May 20, 2009
TEST SAMPLE: ENGINEERING SAMPLE
STANDARDS: **FCC Part 2 (Section 2.1093)**
FCC OET Bulletin 65, Supplement C (01-01)
RSS-102

The above equipment (model: CA1060) has been tested by **Bureau Veritas Consumer Products Services (H.K.) Ltd., Taoyuan Branch**, and found compliance with the requirement of the above standards. The test record, data evaluation & Equipment Under Test (EUT) configurations represented herein are true and accurate accounts of the measurements of the sample's EMC characteristics under the conditions specified in this report.

PREPARED BY :  , **DATE** : May 25, 2009
Joanna Wang / Senior Specialist

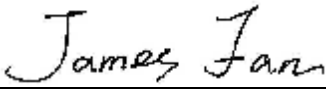
TECHNICAL ACCEPTANCE :  , **DATE** : May 25, 2009
Responsible for RF James Fan / Engineer

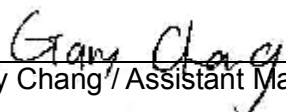
APPROVED BY :  , **DATE** : May 25, 2009
Gary Chang / Assistant Manager

2. GENERAL INFORMATION

2.1 GENERAL DESCRIPTION OF EUT

EUT	WiFi Voice Communication Appliance
MODEL NO.	CA1060
FCC ID	UZ7CA1060
IC ID	109AN-CA1060
POWER SUPPLY	3.9~4.2Vdc from battery
MODULATION TYPE	CCK, DQPSK, DBPSK for DSSS 64QAM, 16QAM, QPSK, BPSK for OFDM
MODULATION TECHNOLOGY	DSSS, OFDM
TRANSFER RATE	802.11b: 11.0/ 5.5/ 2.0/ 1.0Mbps 802.11g: 54.0/ 48.0/ 36.0/ 24.0/ 18.0/ 12.0/ 9.0/ 6.0Mbps
FREQUENCY RANGE	2412 ~ 2462MHz
NUMBER OF CHANNEL	11
CHANNEL FREQUENCIES UNDER TEST AND ITS CONDUCTED OUTPUT POWER	802.11b: 37.068mW / Ch1: 2412MHz 116.681mW / Ch6: 2437MHz 37.325mW / Ch11: 2462MHz 802.11g: 169.824mW / Ch1: 2412MHz 249.459mW / Ch6: 2437MHz 187.499mW / Ch11: 2462MHz
AVERAGE SAR (1g)	0.459W/kg
ANTENNA TYPE	PIFA antenna with -3.5dBi gain
DATA CABLE	NA
I/O PORTS	Female socket
ACCESSORY DEVICES	Headset (0.56m, Brand: AAPC, Model: AEP-KT02D-02)

NOTE:

1. The EUT, operates in the 2.4GHz frequency range, lets you connect IEEE 802.11g or IEEE 802.11b devices to the network. With its high-speed data transmissions up to 54Mbps.
2. The above EUT information was declared by manufacturer and for more detailed features description, please refer to the manufacturer's specifications or user's manual.



2.2 GENERAL DESCRIPTION OF APPLIED STANDARDS

According to the specifications of the manufacturer, this product must comply with the requirements of the following standards:

FCC Part 2 (2.1093)

FCC OET Bulletin 65, Supplement C (01- 01)

RSS-102

IEEE 1528-2003

All test items have been performed and recorded as per the above standards.

2.3 GENERAL INFORMATION OF THE SAR SYSTEM

DASY5 (software 5.0 Build 125) consists of high precision robot, probe alignment sensor, phantom, robot controller, controlled measurement server and near-field probe. The robot includes six axes that can move to the precision position of the DASY5 software defined. The DASY5 software can define the area that is detected by the probe. The robot is connected to controlled box. Controlled measurement server is connected to the controlled robot box. The DAE includes amplifier, signal multiplexing, AD converter, offset measurement and surface detection. It is connected to the Electro-optical coupler (ECO). The ECO performs the conversion from the optical into digital electric signal of the DAE and transfers data to the PC.

EX3DV4 ISOTROPIC E-FIELD PROBE

CONSTRUCTION	Symmetrical design with triangular core Built-in shielding against static charges PEEK enclosure material (resistant to organic solvents, e.g., DGBE)
FREQUENCY	10 MHz to > 6 GHz Linearity: ± 0.2 dB (30 MHz to 6 GHz)
DIRECTIVITY	± 0.3 dB in HSL (rotation around probe axis) ± 0.5 dB in tissue material (rotation normal to probe axis)
DYNAMIC RANGE	10 μ W/g to > 100 mW/g Linearity: ± 0.2 dB (noise: typically < 1 μ W/g)
DIMENSIONS	Overall length: 330 mm (Tip: 20 mm) Tip diameter: 2.5 mm (Body: 12 mm) Typical distance from probe tip to dipole centers: 1 mm
APPLICATION	High precision dosimetric measurements in any exposure scenario (e.g., very strong gradient fields). Only probe which enables compliance testing for frequencies up to 6 GHz with precision of better 30%.

NOTE

1. The Probe parameters have been calibrated by the SPEAG. Please reference "APPENDIX D" for the Calibration Certification Report.
2. For frequencies above 800MHz, calibration in a rectangular wave-guide is used, because wave-guide size is manageable.
3. For frequencies below 800MHz, temperature transfer calibration is used because the wave-guide size becomes relatively large.

TWIN SAM V4.0

CONSTRUCTION	The shell corresponds to the specifications of the Specific Anthropomorphic Mannequin (SAM) phantom defined in IEEE 1528-2003, EN 62209-1 and IEC 62209. It enables the dosimetric evaluation of left and right hand phone usage as well as body mounted usage at the flat phantom region. A cover prevents evaporation of the liquid. Reference markings on the phantom allow the complete setup of all predefined phantom positions and measurement grids by manually teaching three points with the robot.
SHELL THICKNESS	2 ± 0.2mm
FILLING VOLUME	Approx. 25liters
DIMENSIONS	Height: 810mm; Length: 1000mm; Width: 500mm

SYSTEM VALIDATION KITS:

CONSTRUCTION	Symmetrical dipole with 1/4 balun enables measurement of feedpoint impedance with NWA matched for use near flat phantoms filled with brain simulating solutions. Includes distance holder and tripod adaptor
CALIBRATION	Calibrated SAR value for specified position and input power at the flat phantom in brain simulating solutions
FREQUENCY	2450MHz
RETURN LOSS	> 20dB at specified validation position
POWER CAPABILITY	> 100W (f < 1GHz); > 40W (f > 1GHz)
OPTIONS	Dipoles for other frequencies or solutions and other calibration conditions upon request

DEVICE HOLDER FOR SAM TWIN PHANTOM

CONSTRUCTION

The device holder for the mobile phone device is designed to cope with different positions given in the standard. It has two scales for the device rotation (with respect to the body axis) and the device inclination (with respect to the line between the ear reference points). The rotation centers for both scales is the ear reference point (ERP). Thus the device needs no repositioning when changing the angles. The holder has been made out of low-loss POM material having the following dielectric parameters: relative permittivity $\varepsilon = 3$ and loss tangent $\delta = 0.02$. The amount of dielectric material has been reduced in the closest vicinity of the device, since measurements have suggested that the influence of the clamp on the test results could thus be lowered. The device holder for the portable device makes up of the polyethylene foam. The dielectric parameters of material close to the dielectric parameters of the air.

DATA ACQUISITION ELECTRONICS

CONSTRUCTION

The data acquisition electronics (DAE4) consists of a highly sensitive electrometer grade preamplifier with auto-zeroing, a channel and gain-switching multiplex, a fast 16 bit AD converter and a command decoder and control logic unit. Transmission to the measurement server is accomplished through an optical downlink for data and status information as well as an optical uplink for commands and the clock. The mechanical probe is mounting device includes two different sensor systems for frontal and sideways probe contacts. They are used for mechanical surface detection and probe collision detection. The input impedance of the DAE4 box is 200M Ω ; the inputs are symmetrical and floating. Common mode rejection is above 80 dB.

2.4 GENERAL DESCRIPTION OF THE SPATIAL PEAK SAR EVALUATION

The DASY5 post-processing software (SEMCAD) automatically executes the following procedures to calculate the field units from the micro-volt readings at the probe connector. The parameters used in the evaluation are stored in the configuration modules of the software:

Probe parameters:	- Sensitivity	Norm _i , a _{i0} , a _{i1} , a _{i2}
	- Conversion factor	ConvF _i
	- Diode compression point	dcp _i
Device parameters:	- Frequency	F
	- Crest factor	Cf
Media parameters:	- Conductivity	σ
	- Density	ρ

The first step of the evaluation is a linearization of the filtered input signal to account for the compression characteristics of the detector diode. The compensation depends on the input signal, the diode type and the DC-transmission factor from the diode to the evaluation electronics. If the exciting field is pulsed, the crest factor of the signal must be known to correctly compensate for peak power. The formula for each channel can be given as:

$$V_i = U_i + U_i^2 \cdot \frac{cf}{dcp_i}$$

V _i	=compensated signal of channel i	(i = x, y, z)
U _i	=input signal of channel i	(i = x, y, z)
Cf	=crest factor of exciting field	(DASY parameter)
dcp _i	=diode compression point	(DASY parameter)

From the compensated input signals the primary field data for each channel can be evaluated:

$$\text{E-field probes: } E_i = \sqrt{\frac{V_i}{\text{Norm}_i \cdot \text{ConvF}}}$$

$$\text{H-field probes: } H_i = \sqrt{V_i} \cdot \frac{a_{i0} + a_{i1}f + a_{i2}f^2}{f}$$

V_i	=compensated signal of channel I	(i = x, y, z)
Norm_i	=sensor sensitivity of channel i $\mu\text{V}/(\text{V/m})^2$ for E-field Probes	(i = x, y, z)
ConvF	= sensitivity enhancement in solution	
a_{ij}	= sensor sensitivity factors for H-field probes	
f	= carrier frequency [GHz]	
E_i	= electric field strength of channel i in V/m	
H_i	= magnetic field strength of channel i in A/m	

The RSS value of the field components gives the total field strength (Hermitian magnitude):

$$E_{tot} = \sqrt{E_x^2 + E_y^2 + E_z^2}$$

The primary field data are used to calculate the derived field units.

$$SAR = E_{tot}^2 \cdot \frac{S}{r \cdot 1'000}$$

SAR	= local specific absorption rate in mW/g
E_{tot}	= total field strength in V/m
σ	= conductivity in [mho/m] or [Siemens/m]
ρ	= equivalent tissue density in g/cm ³

Note that the density is set to 1, to account for actual head tissue density rather than the density of the tissue simulating liquid. The entire evaluation of the spatial peak values is performed within the Post-processing engine (SEMCAD). The system always gives the maximum values for the 1g and 10g cubes. The algorithm to find the cube with highest averaged SAR is divided into the following stages:

1. The extraction of the measured data (grid and values) from the Zoom Scan
2. The calculation of the SAR value at every measurement point based on all stored data (A/D values and measurement parameters)
3. The generation of a high-resolution mesh within the measured volume
4. The interpolation of all measured values from the measurement grid to the high-resolution grid
5. The extrapolation of the entire 3-D field distribution to the phantom surface over the distance from sensor to surface
6. The calculation of the averaged SAR within masses of 1g and 10g.

The probe is calibrated at the center of the dipole sensors that is located 1 to 2.7mm away from the probe tip. During measurements, the probe stops shortly above the phantom surface, depending on the probe and the surface detecting system. Both distances are included as parameters in the probe configuration file. The software always knows exactly how far away the measured point is from the surface. As the probe cannot directly measure at the surface, the values between the deepest measured point and the surface must be extrapolated. The angle between the probe axis and the surface normal line is less than 30 degree.



The maximum search is automatically performed after each area scan measurement. It is based on splines in two or three dimensions. The procedure can find the maximum for most SAR distributions even with relatively large grid spacing. After the area scanning measurement, the probe is automatically moved to a position at the interpolated maximum. The following scan can directly use this position for reference, e.g., for a finer resolution grid or the cube evaluations. The 1g and 10g peak evaluations are only available for the predefined cube 7 x 7 x 7 scans. The routines are verified and optimized for the grid dimensions used in these cube measurements. The measured volume of 30 x 30 x 30mm contains about 30g of tissue. The first procedure is an extrapolation (incl. boundary correction) to get the points between the lowest measured plane and the surface. The next step uses 3D interpolation to get all points within the measured volume in a 1mm grid (42875 points). In the last step, a 1g cube is placed numerically into the volume and its averaged SAR is calculated. This cube is the moved around until the highest averaged SAR is found. If the highest SAR is found at the edge of the measured volume, the system will issue a warning: higher SAR values might be found outside of the measured volume. In that case the cube measurement can be repeated, using the new interpolated maximum as the center.

3. DESCRIPTION OF SUPPORT UNITS

The EUT has been tested as an independent unit together with other necessary accessories or support units. The following support units or accessories were used to form a representative test configuration during the tests.

NO.	PRODUCT	BRAND	MODEL NO.	SERIAL NO.	FCC ID
1	NOTEBOOK	DELL	D600	CN-0G5152-48643 -49C-8226	FCC DoC Approved

NO.	SIGNAL CABLE DESCRIPTION OF THE ABOVE SUPPORT UNITS
1	NA

NOTE: All power cords of the above support units are non shielded (1.8m).

4. DESCRIPTION OF TEST MODES AND CONFIGURATIONS

4.1. DESCRIPTION OF ANTENNA LOCATION



4.2. DESCRIPTION OF ASSESSMENT POSITION

The following test configurations have been applied in this test report:



A (with headset)

The bottom of the EUT faces to the phantom with 0mm-separation distance.



B (without headset)

The bottom of the EUT faces to the phantom with 0mm-separation distance.



SETUP PHOTO

4.3. DESCRIPTION OF TEST MODE

Test tool is Hyper terminal embedded in Windows O/S. Sending specific commands to EUT then EUT will follow commands to transmit at specific channel, output power level, modulation and 100 % duty cycle.

“Per KDB 248277, for each frequency band, testing at higher data rates and higher order modulations is not required when the maximum average output power for each of these configurations is less than ¼ dB higher than those measured at the lowest data rate.”

Comparing output power of all modulations and data rates of each mode can find the lowest data rates has max output power. Therefore, EUT will set under lowest data rates to test.

There are 2 test configurations. One is EUT with headset, the other is without headset. After pretesting of highest output power channel, we find that EUT with headset is worst case. Therefore, only this mode has been tested low, middle and high channel.

ITEM	TEST MODE	MODULATION	ASSESSMENT POSITION	TESTED CHANNEL	REMARK
1	802.11b	DBPSK	A	1, 6, 11	With headset
2	802.11g	BPSK	A	1, 6, 11	
3	802.11b	DBPSK	B	6	Without headset
4	802.11g	BPSK	B	6	

4.4. SUMMARY OF TEST RESULTS

ITEM		1	2	3	4
TEST MODE		802.11b	802.11g	802.11b	802.11g
CHAN.	FREQ. (MHz)	MEASURED VALUE OF 10g SAR (W/kg)			
1	2412 (Low)	0.143	0.134	-	-
6	2437 (Mid.)	0.425	0.459	0.317	0.290
11	2462 (High)	0.110	0.119	-	-

NOTE: The worst value has been marked by boldface.

4.5. ENHANCED ENERGY COUPLING AT INCREASED SEPARATION DISTANCES

INITIAL POSITION:

The probe tip is positioned at the peak SAR location of middle channel in test mode 2 at a distance of one half the probe tip diameter from the phantom surface. Under this condition to get a single SAR value.

5mm / 10mm INCREMENTS FROM INITIAL POSITION:

With the probe fixed at this location, the device is moved away from the phantom in 5mm / 10m increments from the initial touching or minimum separation position. A single point SAR is measured for each of these device positions until the SAR is less than 50% of that measured at the initial position.

CHAN.	FREQ. (MHz)	DEVICE TEST POSITION MODE	INITIAL POSITION MEASURED 1g SAR (W/kg)	5mm INCREMENTS FROM INITIAL POSITION MEASURED 1g SAR (W/kg)	10mm INCREMENTS FROM INITIAL POSITION MEASURED 1g SAR (W/kg)
6	2437	11g Bottom	0.640	0.400	0.240

RESULT: No Enhancement Energy Coupling observed.

5. TEST RESULTS

5.1 TEST PROCEDURES

Use the software to control the EUT channel and transmission power. Then record the conducted power before the testing. Place the EUT to the specific test location. After the testing, must writing down the conducted power of the EUT into the report. The SAR value was calculated via the 3D spline interpolation algorithm that has been implemented in the software of DASY5 SAR measurement system manufactured and calibrated by SPEAG. According to the IEEE 1528 standards, the recommended procedure for assessing the peak spatial-average SAR value consists of the following steps:

- Power reference measurement
- Verification of the power reference measurement
- Area scan
- Zoom scan
- Power reference measurement

The area scan was performed for the highest spatial SAR location. The zoom scan with 30mm x 30mm x 30mm volume was performed for SAR value averaged over 1g and 10g spatial volumes.

In the zoom scan, the distance between the measurement point at the probe sensor location (geometric center behind the probe tip) and the phantom surface is 3mm and maintained at a constant distance of ± 0.5 mm during a zoom scan to determine peak SAR locations. The distance is 3mm between the first measurement point and the bottom surface of the phantom. The secondary measurement point to the bottom surface of the phantom is with 8mm separation distance. The cube size is 7 x 7 x 7 points consists of 343 points and the grid space is 5mm.

The measurement time is 0.5s at each point of the zoom scan. The probe boundary effect compensation shall be applied during the SAR test. Because of the tip of the probe to the Phantom surface separated distances are longer than half a tip probe diameter.

In the area scan, the separation distance is 3mm between the each measurement point and the phantom surface. The scan size shall be included the transmission portion of the EUT. The measurement time is the same as the zoom scan. At last the reference power drift shall be less than $\pm 5\%$.

5.2 MEASURED SAR RESULTS

ENVIRONMENTAL CONDITION			Air Temperature : 23.1°C, Liquid Temperature : 22.8°C Humidity : 62%RH				
TESTED BY			Dylan Chiou		DATE	May 20, 2009	
CHAN.	FREQ. (MHz)	TEST MODE	CONDUCTED POWER (mW)		POWER DRIFT (%)	DEVICE TEST POSITION MODE	MEASURED 1g SAR (W/kg)
			BEGIN TEST	AFTER TEST			
1	2412 (Low)	802.11b	37.068	36.508	-1.51	1	0.143
6	2437 (Mid.)	802.11b	116.681	115.246	-1.23	1	0.425
11	2462 (High)	802.11b	37.325	36.788	-1.44	1	0.110
1	2412 (Low)	802.11g	169.824	167.035	-1.64	2	0.134
6	2437 (Mid.)	802.11g	249.459	245.268	-1.68	2	0.459
11	2462 (High)	802.11g	187.499	184.518	-1.59	2	0.119
6	2437 (Mid.)	802.11b	116.681	115.106	-1.35	3	0.317
6	2437 (Mid.)	802.11g	249.459	245.667	-1.52	4	0.290

NOTE:

1. Test configuration of each mode is described in section 4.3.
2. In this testing, the limit for General Population Spatial Peak averaged over 1g, 1.6 W/kg, is applied.
3. Please see the Appendix A for the data.
4. The variation of the EUT conducted power measured before and after SAR testing should not over 5%.

5.3 SAR LIMITS

HUMAN EXPOSURE	SAR (W/kg)	
	(GENERAL POPULATION / UNCONTROLLED EXPOSURE ENVIRONMENT)	(OCCUPATIONAL / CONTROLLED EXPOSURE ENVIRONMENT)
Spatial Average (whole body)	0.08	0.4
Spatial Peak (averaged over 1 g)	1.6	8.0
Spatial Peak (hands / wrists / feet / ankles averaged over 10 g)	4.0	20.0

NOTE:

1. This limits accord to 47 CFR 2.1093 – Safety Limit.
2. The EUT property been complied with the partial body exposure limit under the general population environment.

5.4 RECIPES FOR TISSUE SIMULATING LIQUIDS

For the measurement of the field distribution inside the SAM phantom, the phantom must be filled with 25 liters of tissue simulation liquid.

The following ingredients are used :

- **WATER-** Deionized water (pure H₂O), resistivity $\approx 16 \text{ M}$ - as basis for the liquid
- **SUGAR-** Refined sugar in crystals, as available in food shops - to reduce relative permittivity
- **SALT-** Pure NaCl - to increase conductivity
- **CELLULOSE-** Hydroxyethyl-cellulose, medium viscosity (75-125mPa.s, 2% in water, 20_C),
CAS # 54290 - to increase viscosity and to keep sugar in solution
- **PRESERVATIVE-** Preventol D-7 Bayer AG, D-51368 Leverkusen, CAS # 55965-84-9 - to prevent the spread of bacteria and molds
- **DGMBE-** Diethylenglycol-monobuthyl ether (DGMBE), Fluka Chemie GmbH, CAS # 112-34-5 - to reduce relative permittivity

THE RECIPES FOR 2450MHz SIMULATING LIQUID TABLE

INGREDIENT	HEAD SIMULATING LIQUID 2450MHz (HSL-2450)	MUSCLE SIMULATING LIQUID 2450MHz (MSL-2450)
Water	45%	69.83%
DGMBE	55%	30.17%
Salt	NA	NA
Dielectric Parameters at 22°C	f= 2450MHz $\epsilon = 39.2 \pm 5\%$ $\sigma = 1.80 \pm 5\% \text{ S/m}$	f= 2450MHz $\epsilon = 52.7 \pm 5\%$ $\sigma = 1.95 \pm 5\% \text{ S/m}$

Testing the liquids using the Agilent Network Analyzer E8358A and Agilent Dielectric Probe Kit 85070D. The testing procedure is following as

1. Turn Network Analyzer on and allow at least 30min. warm up.
2. Mount dielectric probe kit so that interconnecting cable to Network Analyzer will not be moved during measurements or calibration.
3. Pour de-ionized water and measure water temperature ($\pm 1^\circ$).
4. Set water temperature in Agilent-Software (Calibration Setup).
5. Perform calibration.
6. Validate calibration with dielectric material of known properties (e.g. polished ceramic slab with $>8\text{mm}$ thickness $\epsilon' = 10.0$, $\epsilon'' = 0.0$). If measured parameters do not fit within tolerance, repeat calibration (± 0.2 for ϵ' : ± 0.1 for ϵ'').
7. Conductivity can be calculated from ϵ'' by $\sigma = \omega \epsilon_0 \epsilon'' = \epsilon'' f [\text{GHz}] / 18$.
8. Measure liquid shortly after calibration. Repeat calibration every hour.
9. Stir the liquid to be measured. Take a sample ($\sim 50\text{ml}$) with a syringe from the center of the liquid container.
10. Pour the liquid into a small glass flask. Hold the syringe at the bottom of the flask to avoid air bubbles.
11. Put the dielectric probe in the glass flask. Check that there are no air bubbles in front of the opening in the dielectric probe kit.
12. Perform measurements.
13. Adjust medium parameters in DASY5 for the frequencies necessary for the measurements ('Setup Config', select medium (e.g. Brain 900MHz) and press 'Option'-button.
14. Select the current medium for the frequency of the validation (e.g. Setup Medium Brain 900MHz).



FOR 2.4GHz BAND SIMULATING LIQUID

LIQUID TYPE		MSL-2450		
SIMULATING LIQUID TEMP.		22.8		
TEST DATE		May 20, 2009		
TESTED BY		Dylan Chiou		
FREQ. (MHz)	LIQUID PARAMETER	STANDARD VALUE	MEASUREMENT VALUE	ERROR PERCENTAGE (%)
2412	Permittivity (ϵ)	52.80	54.00	2.27
2437		52.70	53.90	2.28
2450		52.70	53.80	2.09
2462		52.70	53.70	1.90
2412	Conductivity (σ) S/m	1.91	1.96	2.62
2437		1.94	1.98	2.06
2450		1.95	2.00	2.56
2462		1.97	2.01	2.03
Dielectric Parameters Required at 22°C		f= 2450MHz $\epsilon= 52.7 \pm 5\%$ $\sigma= 1.95 \pm 5\%$ S/m		



5.5 TEST EQUIPMENT FOR TISSUE PROPERTY

ITEM	NAME	BRAND	TYPE	SERIES NO.	DATE OF CALIBRATION	DUE DATE OF CALIBRATION
1	Network Analyzer	Agilent	E8358A	US41480538	Nov. 27, 2008	Nov. 26, 2009
2	Dielectric Probe	Agilent	85070D	US01440176	NA	NA

NOTE:

1. Before starting, all test equipment shall be warmed up for 30min.
2. The tolerance ($k=1$) specified by Agilent for general dielectric measurements, deriving from inaccuracies in the calibration data, analyzer drift, and random errors, are usually $\pm 2.5\%$ and $\pm 5\%$ for measured permittivity and conductivity, respectively. However, the tolerances for the conductivity is smaller for material with large loss tangents, i.e., less than $\pm 2.5\%$ ($k=1$). It can be substantially smaller if more accurate methods are applied.

6. SYSTEM VALIDATION

The system validation was performed in the flat phantom with equipment listed in the following table. Since the SAR value is calculated from the measured electric field, dielectric constant and conductivity of the body tissue and the SAR is proportional to the square of the electric field. So, the SAR value will be also proportional to the RF power input to the system validation dipole under the same test environment. In our system validation test, 250mW RF input power was used.

6.1 TEST EQUIPMENT

ITEM	NAME	BRAND	TYPE	SERIES NO.	DATE OF CALIBRATION	DUE DATE OF CALIBRATION
1	SAM Phantom	S & P	QD000 P40 CA	TP-1150	NA	NA
2	Signal Generator	Anritsu	68247B	984703	May 27, 2008	May 26, 2009
3	E-Field Probe	S & P	EX3DV4	3590	Apr. 28, 2009	Apr. 27, 2010
4	DAE	S & P	DAE4	861	Sep. 22, 2008	Sep. 21, 2009
5	Robot Positioner	Staubli Unimation	NA	NA	NA	NA
6	Validation Dipole	S & P	D2450V2	716	Mar. 17, 2009	Mar. 16, 2010

NOTE: Before starting the measurement, all test equipment shall be warmed up for 30min.

6.2 TEST PROCEDURE

Before the system performance check, we need only to tell the system which components (probe, medium, and device) are used for the system performance check; the system will take care of all parameters. The dipole must be placed beneath the flat section of the SAM Twin Phantom with the correct distance holder in place. The distance holder should touch the phantom surface with a light pressure at the reference marking (little cross) and be oriented parallel to the long side of the phantom. Accurate positioning is not necessary, since the system will search for the peak SAR location, except that the dipole arms should be parallel to the surface. The device holder for mobile phones can be left in place but should be rotated away from the dipole.

1. The "Power Reference Measurement" and "Power Drift Measurement" jobs are located at the beginning and end of the batch process. They measure the field drift at one single point in the liquid over the complete procedure. The indicated drift is mainly the variation of the amplifier output power. If it is too high (above ± 0.1 dB), the system performance check should be repeated; some amplifiers have very high drift during warm-up. A stable amplifier gives drift results in the DASY system below ± 0.02 dB.
2. The "Surface Check" job tests the optical surface detection system of the DASY system by repeatedly detecting the surface with the optical and mechanical surface detector and comparing the results. The output gives the detecting heights of both systems, the difference between the two systems and the standard deviation of the detection repeatability. Air bubbles or refraction in the liquid due to separation of the sugar-water mixture gives poor repeatability (above ± 0.1 mm). In that case it is better to abort the system performance check and stir the liquid.

3. The "Area Scan" job measures the SAR above the dipole on a plane parallel to the surface. It is used to locate the approximate location of the peak SAR. The proposed scan uses large grid spacing for faster measurement; due to the symmetric field, the peak detection is reliable. If a finer graphic is desired, the grid spacing can be reduced. Grid spacing and orientation have no influence on the SAR result.
4. The "Zoom Scan" job measures the field in a volume around the peak SAR value assessed in the previous "Area Scan" job (for more information see the application note on SAR evaluation).

About the validation dipole positioning uncertainty, the constant and low loss dielectric spacer is used to establish the correct distance between the top surface of the dipole and the bottom surface of the phantom, the error component introduced by the uncertainty of the distance between the liquid (i.e., phantom shell) and the validation dipole in the DASYS system is less than ± 0.1 mm.

$$SAR_{tolerance} [\%] = 100 \times \left(\frac{(a + d)^2}{a^2} - 1 \right)$$

As the closest distance is 10mm, the resulting tolerance $SAR_{tolerance} [\%]$ is <2%.

6.3 VALIDATION RESULTS

SYSTEM VALIDATION TEST OF SIMULATING LIQUID					
FREQUENCY (MHz)	REQUIRED SAR (mW/g)	MEASURED SAR (mW/g)	DEVIATION (%)	SEPARATION DISTANCE	TESTED DATE
MSL2450	13.30 (1g)	12.90	-3.01	10mm	May 20, 2009
TESTED BY	Dylan Chiou				

NOTE: Please see Appendix for the photo of system validation test.



6.4 SYSTEM VALIDATION UNCERTAINTIES

In the table below, the system validation uncertainty with respect to the analytically assessed SAR value of a dipole source as given in the IEEE 1528 standard is given. This uncertainty is smaller than the expected uncertainty for mobile phone measurements due to the simplified setup and the symmetric field distribution.

Error Description	Tolerance (±%)	Probability Distribution	Divisor	(C _i)		Standard Uncertainty (±%)		(v _i)
				(1g)	(10g)	(1g)	(10g)	
Measurement System								
Probe Calibration	5.50	Normal	1	1	1	5.50	5.50	∞
Axial Isotropy	4.70	Rectangular	√3	0.7	0.7	1.90	1.90	∞
Hemispherical Isotropy	9.60	Rectangular	√3	0.7	0.7	3.88	3.88	∞
Boundary effects	1.00	Rectangular	√3	1	1	0.58	0.58	∞
Linearity	4.70	Rectangular	√3	1	1	2.71	2.71	∞
System Detection Limits	1.00	Rectangular	√3	1	1	0.58	0.58	∞
Readout Electronics	0.30	Normal	1	1	1	0.30	0.30	∞
Response Time	0.80	Rectangular	√3	1	1	0.46	0.46	∞
Integration Time	2.60	Rectangular	√3	1	1	1.50	1.50	∞
RF Ambient Noise	3.00	Rectangular	√3	1	1	1.73	1.73	∞
RF Ambient Reflections	3.00	Rectangular	√3	1	1	1.73	1.73	∞
Probe Positioner	0.40	Rectangular	√3	1	1	0.23	0.23	∞
Probe Positioning	2.90	Rectangular	√3	1	1	1.67	1.67	∞
Max. SAR Eval.	1.00	Rectangular	√3	1	1	0.58	0.58	∞
Dipole Related								
Dipole Axis to Liquid Distance	2.00	Rectangular	√3	1	1	1.15	1.15	145
Input Power Drift	5.00	Rectangular	√3	1	1	2.89	2.89	∞
Phantom and Tissue parameters								
Phantom Uncertainty	4.00	Rectangular	√3	1	1	2.31	2.31	∞
Liquid Conductivity (target)	5.00	Rectangular	√3	0.64	0.43	1.85	1.24	∞
Liquid Conductivity (measurement)	3.31	Normal	1	0.64	0.43	2.12	1.42	∞
Liquid Permittivity (target)	5.00	Rectangular	√3	0.6	0.49	1.73	1.41	∞
Liquid Permittivity (measurement)	3.05	Normal	1	0.6	0.49	1.83	1.49	∞
Combined Standard Uncertainty						9.90	9.56	
Coverage Factor for 95%						Kp=2		
Expanded Uncertainty (K=2)						19.79	19.13	

NOTE: About the system validation uncertainty assessment, please reference the section 7.

7. MEASUREMENT SAR PROCEDURE UNCERTAINTIES

The assessment of spatial peak SAR of the hand handheld devices is according to IEEE 1528 / EN 62209-1. All testing situation shall be met below these requirements.

- The system is used by an experienced engineer who follows the manual and the guidelines taught during the training provided by SPEAG.
- The probe has been calibrated within the requested period and the stated uncertainty for the relevant frequency bands does not exceed 4.8% ($k=1$).
- The validation dipole has been calibrated within the requested period and the system performance check has been successful.
- The DAE unit has been calibrated within the within the requested period.
- The minimum distance between the probe sensor and inner phantom shell is selected to be between 4 and 5mm.
- The operational mode of the DUT is CW, CDMA, FDMA or TDMA (GSM, DCS, PCS, IS136 and PDC) and the measurement/integration time per point is >500 ms.
- The dielectric parameters of the liquid have been assessed using Agilent 85070D dielectric probe kit or a more accurate method.
- The dielectric parameters are within 5% of the target values.
- The DUT has been positioned as described in section 3.

7.1. PROBE CALIBRATION UNCERTAINTY

SPEAG conducts the probe calibration in compliance with international and national standards (e.g. IEEE 1528, EN 62209-1, IEC 62209, etc.) under ISO17025. The uncertainties are stated on the calibration certificate. For the most relevant frequency bands, these values do not exceed 4.8% ($k=1$). If evaluations of other bands are performed for which the uncertainty exceeds these values, the uncertainty tables given in the summary have to be revised accordingly.

7.2. ISOTROPY UNCERTAINTY

The axial isotropy tolerance accounts for probe rotation around its axis while the hemispherical isotropy error includes all probe orientations and field polarizations. These parameters are assessed by SPEAG during initial calibration. In 2001, SPEAG further tightened its quality controls and warrants that the maximal deviation from axial isotropy is $\pm 0.20\text{dB}$, while the maximum deviation of hemispherical isotropy is $\pm 0.40\text{dB}$, corresponding to $\pm 4.7\%$ and $\pm 9.6\%$, respectively. A weighting factor of c_p equal to 0.5 can be applied, since the axis of the probe deviates less than 30 degrees from the normal surface orientation.

7.3. BOUNDARY EFFECT UNCERTAINTY

The effect can be estimated according to the following error approximation formula

$$SAR_{tolerance}[\%] = SAR_{be}[\%] \times \frac{(d_{be} + d_{step})^2}{2d_{step}} \frac{e^{-\frac{d_{be}}{\delta/2}}}{d/2}$$

$$d_{be} + d_{step} < 10\text{mm}$$

The parameter d_{be} is the distance in mm between the surface and the closest measurement point used in the averaging process; d_{step} is the separation distance in mm between the first and second measurement points; δ is the minimum penetration depth in mm within the head tissue equivalent liquids (i.e., $\delta = 13.95\text{mm}$ at 3GHz); SAR_{be} is the deviation between the measured SAR value at the distance d_{be} from the boundary and the wave-guide analytical value $SAR_{ref.DASY5}$ applies a boundary effect compensation algorithm according to IEEE 1528, which is possible since the axis of the probe never deviates more than 30 degrees from the normal surface orientation. $SAR_{be}[\%]$ is assessed during the calibration process and SPEAG warrants that the uncertainty at distances larger than 4mm is always less than 1%. In summary, the worst case boundary effect SAR tolerance[%] for scanning distances larger than 4mm is $< \pm 0.8\%$.

7.4. PROBE LINEARITY UNCERTAINTY

Field probe linearity uncertainty includes errors from the assessment and compensation of the diode compression effects for CW and pulsed signals with known duty cycles. This error is assessed using the procedure described in IEEE 1528 / EN 62209-1. For SPEAG field probes, the measured difference between CW and pulsed signals, with pulse frequencies between 10Hz and 1kHz and duty cycles between 1 and 100, is $< \pm 0.20\text{dB}$ ($< \pm 4.7\%$).

7.5. READOUT ELECTRONICS UNCERTAINTY

All uncertainties related to the probe readout electronics (DAE unit), including the gain and linearity of the instrumentation amplifier, its loading effect on the probe, and accuracy of the signal conversion algorithm, have been assessed accordingly to IEEE 1528 / EN 62209-1. The combination (root-sum-square RSS method) of these components results in an overall maximum error of $\pm 1.0\%$.

7.6. RESPONSE TIME UNCERTAINTY

The time response of the field probes is assessed by exposing the probe to a well-controlled electric field producing SAR larger than 2.0W/kg at the tissue medium surface. The signal response time is evaluated as the time required by the system to reach 90% of the expected final value after an on/of switch of the power source. Analytically, it can be expressed as:

$$SAR_{tolerance} [\%] = 100 \times \left(\frac{T_m}{T_m + te^{-T_m/t} - t} - 1 \right)$$

where T_m is 500 ms, i.e., the time between measurement samples, and τ the time constant. The response time τ of SPEAG's probes is $< 5\text{ms}$. In the current implementation, DASY5 waits longer than 100 ms after having reached the grid point before starting a measurement, i.e., the response time uncertainty is negligible.

7.7. INTEGRATION TIME UNCERTAINTY

If the device under test does not emit a CW signal, the integration time applied to measure the electric field at a specific point may introduce additional uncertainties due to the discretization and can be assessed as follows

$$SAR_{tolerance} [\%] = 100 \times \sum_{all\ sub-frames} \frac{t_{frame}}{t_{integration}} \frac{slot_{idle}}{slot_{total}}$$

The tolerances for the different systems are given in Table 7.1, whereby the worst-case $SAR_{tolerance}$ is 2.6%.

System	$SAR_{tolerance}$ %
CW	0
CDMA*	0
WCDMA*	0
FDMA	0
IS-136	2.6
PDC	2.6
GSM/DCS/PCS	1.7
DECT	1.9
Worst-Case	2.6

TABLE 7.1

7.8. PROBE POSITIONER MECHANICAL TOLERANCE

The mechanical tolerance of the field probe positioner can introduce probe positioning uncertainties. The resulting SAR uncertainty is assessed by comparing the SAR obtained according to the specifications of the probe positioner with respect to the actual position defined by the geometric center of the probe sensors. The tolerance is determined as:

$$SAR_{tolerance} [\%] = 100 \times \frac{d_{ph}}{d/2}$$

The specified repeatability of the RX robot family used in DASY5 systems is $\pm 25\mu\text{m}$. The absolute accuracy for short distance movements is better than $\pm 0.1\text{mm}$, i.e., the $SAR_{tolerance}[\%]$ is better than 1.5% (rectangular).

7.9. PROBE POSITIONING

The probe positioning procedures affect the tolerance of the separation distance between the probe tip and the phantom surface as:

$$SAR_{tolerance} [\%] = 100 \times \frac{d_{ph}}{d/2}$$

where d_{ph} is the maximum deviation of the distance between the probe tip and the phantom surface. The optical surface detection has a precision of better than 0.2mm, resulting in an $SAR_{tolerance}[\%]$ of <2.9% (rectangular distribution). Since the mechanical detection provides better accuracy, 2.9% is a worst-case figure for DASY5 system.

7.10. PHANTOM UNCERTAINTY

The SAR measurement uncertainty due to SPEAG phantom shell production tolerances has been evaluated using

$$SAR_{tolerance}[\%] \cong 100 \times \frac{2d}{a}, \quad d \ll a$$

For a maximum deviation d of the inner and outer shell of the phantom from that specified in the CAD file of $\pm 0.2\text{mm}$, and a 10mm spacing a between source and tissue liquid, the calculated phantom uncertainty is $\pm 4.0\%$.



7.11. DASY5 UNCERTAINTY BUDGET

Error Description	Tolerance (±%)	Probability Distribution	Divisor	(C _i)		Standard Uncertainty (±%)		(v _i)
				(1g)	(10g)	(1g)	(10g)	
Measurement Equipment								
Probe Calibration	5.50	Normal	1	1	1	5.50	5.50	∞
Axial Isotropy	4.70	Rectangular	√3	0.7	0.7	1.90	1.90	∞
Hemispherical Isotropy	9.60	Rectangular	√3	0.7	0.7	3.88	3.88	∞
Boundary effects	1.00	Rectangular	√3	1	1	0.58	0.58	∞
Linearity	4.70	Rectangular	√3	1	1	2.71	2.71	∞
System Detection Limits	1.00	Rectangular	√3	1	1	0.58	0.58	∞
Readout Electronics	0.30	Normal	1	1	1	0.30	0.30	∞
Response Time	0.80	Rectangular	√3	1	1	0.46	0.46	∞
Integration Time	2.60	Rectangular	√3	1	1	1.50	1.50	∞
RF Ambient Noise	3.00	Rectangular	√3	1	1	1.73	1.73	∞
RF Ambient Reflections	3.00	Rectangular	√3	1	1	1.73	1.73	∞
Probe Positioner	0.40	Rectangular	√3	1	1	0.23	0.23	∞
Probe Positioning	2.90	Rectangular	√3	1	1	1.67	1.67	∞
Max. SAR Eval.	1.00	Rectangular	√3	1	1	0.58	0.58	∞
Test Sample Related								
Device Positioning	0.89	Normal	1	1	1	0.89	0.89	9
Device Holder	3.60	Normal	1	1	1	3.60	3.60	5
Power Drift	5.00	Rectangular	√3	1	1	2.89	2.89	∞
Phantom and Tissue parameters								
Phantom Uncertainty	4.00	Rectangular	√3	1	1	2.31	2.31	∞
Liquid Conductivity (target)	5.00	Rectangular	√3	0.64	0.43	1.85	1.24	∞
Liquid Conductivity (measurement)	3.31	Normal	1	0.64	0.43	2.12	1.42	∞
Liquid Permittivity (target)	5.00	Rectangular	√3	0.6	0.49	1.73	1.41	∞
Liquid Permittivity (measurement)	3.05	Normal	1	0.6	0.49	1.83	1.49	∞
Combined Standard Uncertainty						10.51	10.19	
Coverage Factor for 95%						Kp=2		
Expanded Uncertainty (K=2)						21.01	20.39	

TABLE 7.2

The table 7.2: Worst-Case uncertainty budget for DASY5 assessed according to IEEE 1528. The budget is valid for the frequency range 300MHz ~ 3GHz and represents a worst-case analysis. For specific tests and configurations, the uncertainty could be considerable smaller.



8. INFORMATION ON THE TESTING LABORATORIES

We, Bureau Veritas Consumer Products Services (H.K.) Ltd., Taoyuan Branch, were founded in 1988 to provide our best service in EMC, Radio, Telecom and Safety consultation. Our laboratories are accredited and approved by the following approval agencies according to ISO/IEC 17025.

USA	FCC, NVLAP
GERMANY	TUV Rheinland
JAPAN	VCCI
NORWAY	NEMKO
CANADA	INDUSTRY CANADA, CSA
R.O.C.	TAF, BSMI, NCC
NETHERLANDS	Telefication
SINGAPORE	GOST-ASIA (MOU)
RUSSIA	CERTIS (MOU)

Copies of accreditation certificates of our laboratories obtained from approval agencies can be downloaded from our web site: www.adt.com.tw/index.5/phtml. If you have any comments, please feel free to contact us at the following:

Linko EMC/RF Lab:
Tel: 886-2-26052180
Fax: 886-2-26051924

Hsin Chu EMC/RF Lab:
Tel: 886-3-5935343
Fax: 886-3-5935342

Hwa Ya EMC/RF/Safety/Telecom Lab:
Tel: 886-3-3183232
Fax: 886-3-3185050

Web Site: www.adt.com.tw

The address and road map of all our labs can be found in our web site also.

---END---

APPENDIX A: TEST DATA

Liquid Level Photo

Tissue MSL2450MHz D=151mm

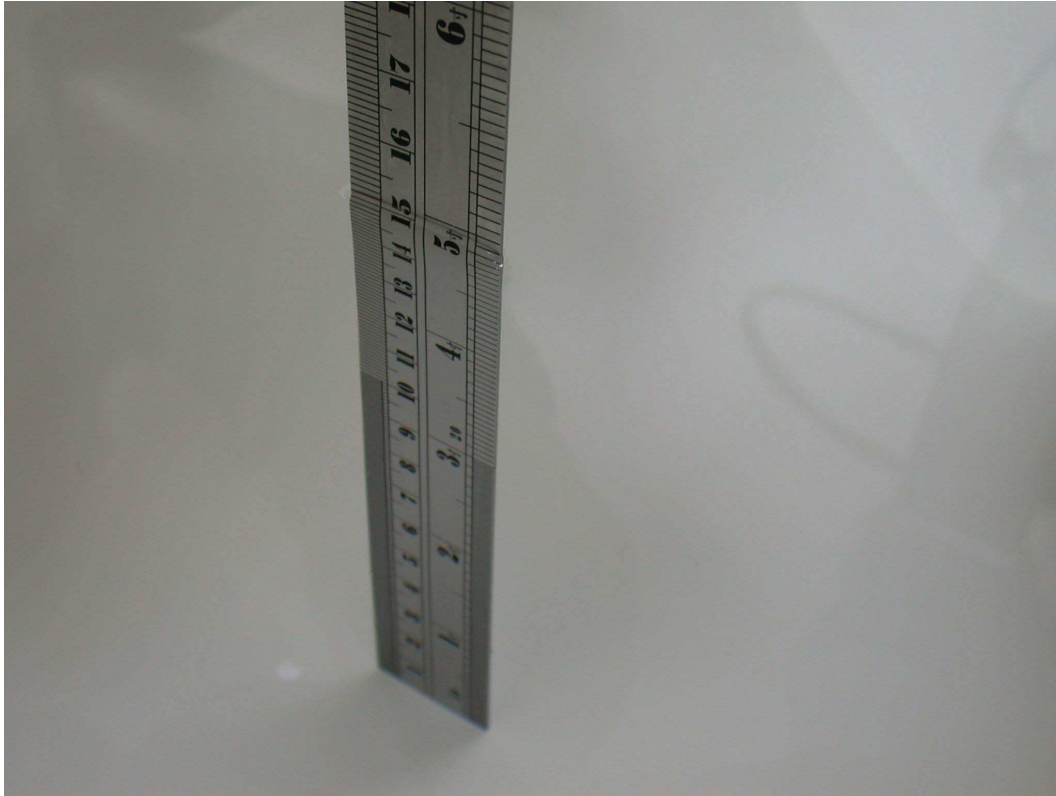

Test Laboratory: Bureau Veritas ADT

M01-Body bottom 11B Ch1

DUT: WiFi Voice Communication Appliance ; Type: CA1060

Communication System: 802.11b ; Frequency: 2412 MHz ; Duty Cycle: 1:1 ; Modulation type: DBPSK
Medium: MSL2450 Medium parameters used: $f = 2412$ MHz; $\sigma = 1.96$ mho/m; $\epsilon_r = 54$; $\rho = 1000$ kg/m³
Phantom section: Flat Section ; Separation distance : 0 mm (The tip side of the EUT to the Phantom)

DASY5 Configuration:

- Probe: EX3DV4 - SN3590 ; ConvF(7.96, 7.96, 7.96) ; Calibrated: 2009/4/28
- Sensor-Surface: 3mm (Mechanical Surface Detection)
- Electronics: DAE4 Sn861 ; Calibrated: 2008/9/22
- Phantom: SAM with CRP ; Type: SAM ; Serial: TP-1485
- Measurement SW: DASY5, V5.0 Build 125 ; SEMCAD X Version 13.4 Build 125

Low Channel 1/Area Scan (5x7x1): Measurement grid: dx=15mm, dy=15mm

Maximum value of SAR (measured) = 0.179 mW/g

Low Channel 1/Zoom Scan (7x7x7) (7x7x7)/Cube 0: Measurement grid: dx=5mm, dy=5mm, dz=5mm

Reference Value = 4.23 V/m

Peak SAR (extrapolated) = 0.253 W/kg

SAR(1 g) = **0.143 mW/g**; SAR(10 g) = 0.079 mW/g

Maximum value of SAR (measured) = 0.174 mW/g

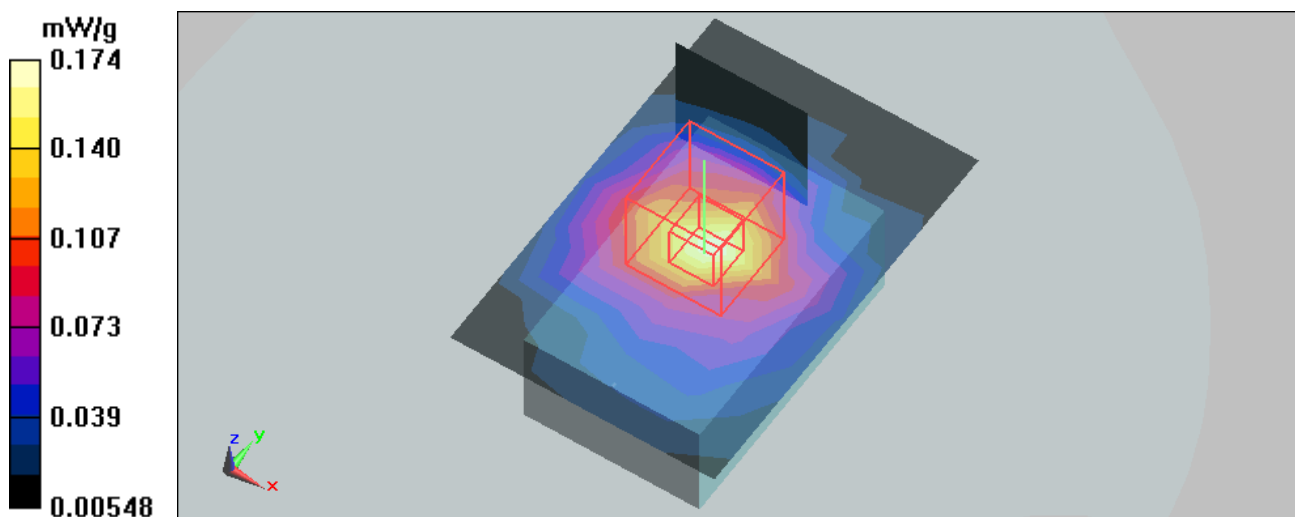

Test Laboratory: Bureau Veritas ADT

M01-Body bottom 11B Ch6

DUT: WiFi Voice Communication Appliance ; Type: CA1060

Communication System: 802.11b ; Frequency: 2437 MHz ; Duty Cycle: 1:1 ; Modulation type: DBPSK
Medium: MSL2450 Medium parameters used: $f = 2437$ MHz; $\sigma = 1.98$ mho/m; $\epsilon_r = 53.9$; $\rho = 1000$ kg/m³
Phantom section: Flat Section ; Separation distance : 0 mm (The tip side of the EUT to the Phantom)

DASY5 Configuration:

- Probe: EX3DV4 - SN3590 ; ConvF(7.96, 7.96, 7.96) ; Calibrated: 2009/4/28
- Sensor-Surface: 3mm (Mechanical Surface Detection)
- Electronics: DAE4 Sn861 ; Calibrated: 2008/9/22
- Phantom: SAM with CRP ; Type: SAM ; Serial: TP-1485
- Measurement SW: DASY5, V5.0 Build 125 ; SEMCAD X Version 13.4 Build 125

Mid Channel 6 power set 18dBm/Area Scan (5x7x1): Measurement grid: dx=15mm, dy=15mm
Maximum value of SAR (measured) = 0.526 mW/g

Mid Channel 6 power set 18dBm/Zoom Scan (7x7x7) (7x7x7)/Cube 0: Measurement grid:
dx=5mm, dy=5mm, dz=5mm
Reference Value = 8.05 V/m
Peak SAR (extrapolated) = 0.786 W/kg
SAR(1 g) = 0.425 mW/g; SAR(10 g) = 0.230 mW/g
Maximum value of SAR (measured) = 0.523 mW/g

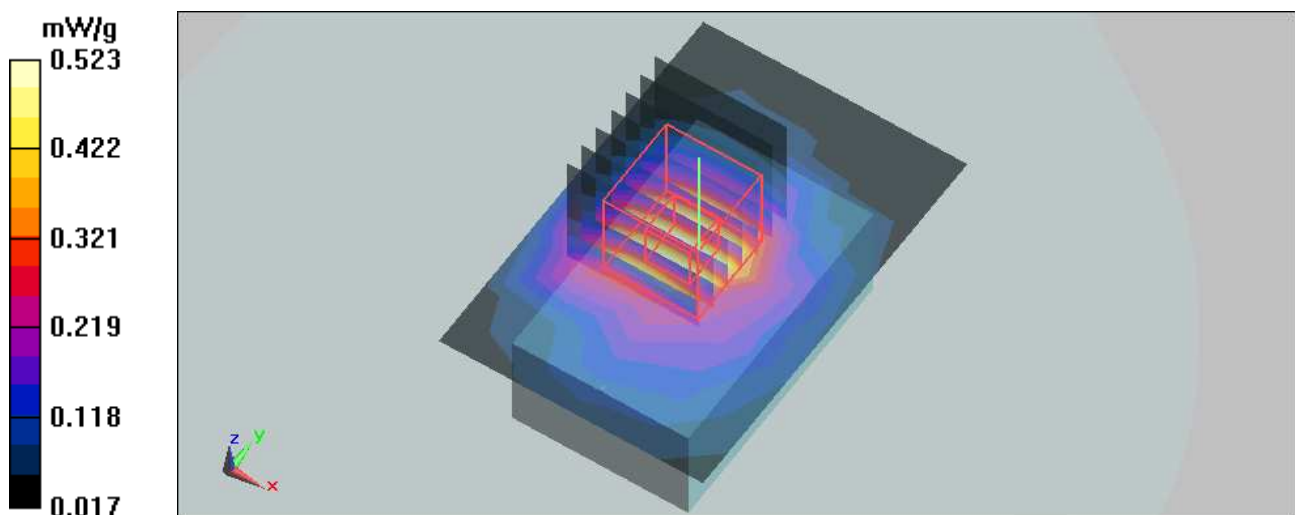

Test Laboratory: Bureau Veritas ADT

M01-Body bottom 11B Ch11

DUT: WiFi Voice Communication Appliance ; Type: CA1060

Communication System: 802.11b ; Frequency: 2462 MHz ; Duty Cycle: 1:1 ; Modulation type: DBPSK
Medium: MSL2450 Medium parameters used: $f = 2462$ MHz; $\sigma = 2.01$ mho/m; $\epsilon_r = 53.7$; $\rho = 1000$ kg/m³
Phantom section: Flat Section ; Separation distance : 0 mm (The tip side of the EUT to the Phantom)

DASY5 Configuration:

- Probe: EX3DV4 - SN3590 ; ConvF(7.96, 7.96, 7.96) ; Calibrated: 2009/4/28
- Sensor-Surface: 3mm (Mechanical Surface Detection)
- Electronics: DAE4 Sn861 ; Calibrated: 2008/9/22
- Phantom: SAM with CRP ; Type: SAM ; Serial: TP-1485
- Measurement SW: DASY5, V5.0 Build 125 ; SEMCAD X Version 13.4 Build 125

High Channel 11/Area Scan (5x7x1): Measurement grid: dx=15mm, dy=15mm

Maximum value of SAR (measured) = 0.136 mW/g

High Channel 11/Zoom Scan (7x7x7) (7x7x7)/Cube 0: Measurement grid: dx=5mm, dy=5mm, dz=5mm

Reference Value = 3.71 V/m

Peak SAR (extrapolated) = 0.201 W/kg

SAR(1 g) = **0.110 mW/g**; SAR(10 g) = 0.060 mW/g

Maximum value of SAR (measured) = 0.135 mW/g

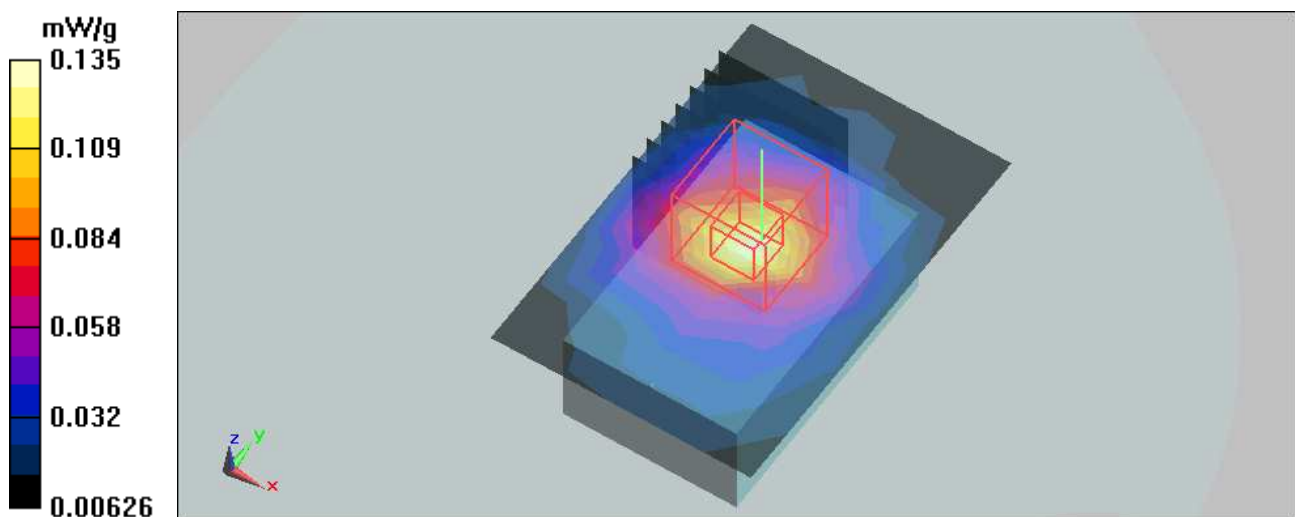

Test Laboratory: Bureau Veritas ADT

M02-Body bottom 11G Ch1

DUT: WiFi Voice Communication Appliance ; Type: CA1060

Communication System: 802.11g ; Frequency: 2412 MHz ; Duty Cycle: 1:1 ; Modulation type: BPSK
Medium: MSL2450 Medium parameters used: $f = 2412$ MHz; $\sigma = 1.96$ mho/m; $\epsilon_r = 54$; $\rho = 1000$ kg/m³
Phantom section: Flat Section ; Separation distance : 0 mm (The tip side of the EUT to the Phantom)

DASY5 Configuration:

- Probe: EX3DV4 - SN3590 ; ConvF(7.96, 7.96, 7.96) ; Calibrated: 2009/4/28
- Sensor-Surface: 3mm (Mechanical Surface Detection)
- Electronics: DAE4 Sn861 ; Calibrated: 2008/9/22
- Phantom: SAM with CRP ; Type: SAM ; Serial: TP-1485
- Measurement SW: DASY5, V5.0 Build 125 ; SEMCAD X Version 13.4 Build 125

Low Channel 1/Area Scan (5x7x1): Measurement grid: dx=15mm, dy=15mm

Maximum value of SAR (measured) = 0.169 mW/g

Low Channel 1/Zoom Scan (7x7x7) (7x7x7)/Cube 0: Measurement grid: dx=5mm, dy=5mm, dz=5mm

Reference Value = 4.15 V/m

Peak SAR (extrapolated) = 0.237 W/kg

SAR(1 g) = **0.134 mW/g**; SAR(10 g) = 0.074 mW/g

Maximum value of SAR (measured) = 0.163 mW/g

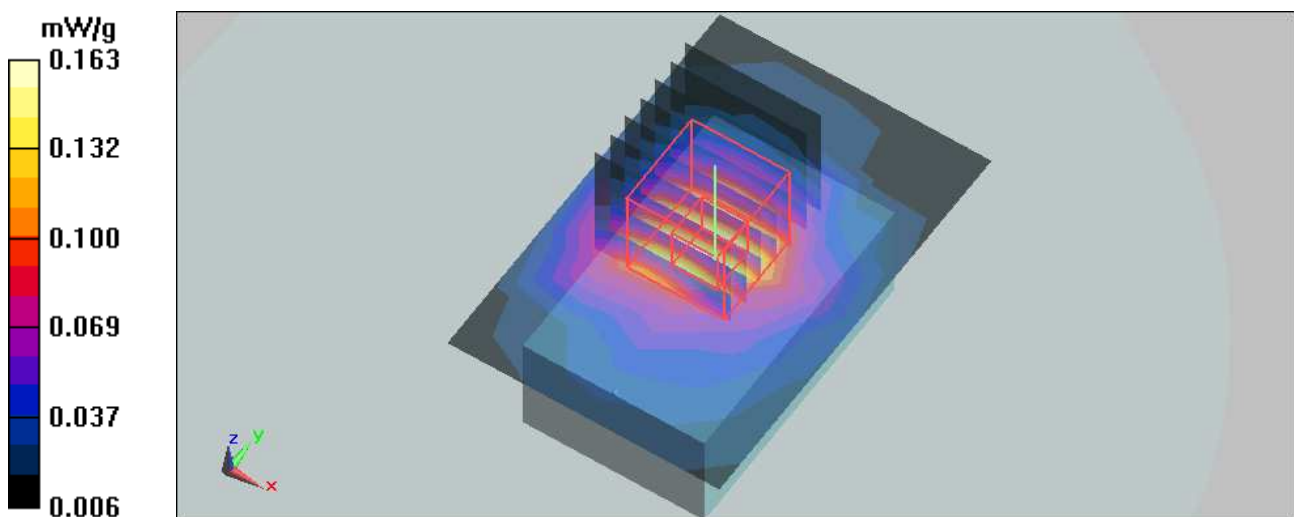

Test Laboratory: Bureau Veritas ADT

M02-Body bottom 11G Ch6

DUT: WiFi Voice Communication Appliance ; Type: CA1060

Communication System: 802.11g ; Frequency: 2437 MHz ; Duty Cycle: 1:1 ; Modulation type: BPSK
Medium: MSL2450 Medium parameters used: $f = 2437$ MHz; $\sigma = 1.98$ mho/m; $\epsilon_r = 53.9$; $\rho = 1000$ kg/m³
Phantom section: Flat Section ; Separation distance : 0 mm (The tip side of the EUT to the Phantom)

DASY5 Configuration:

- Probe: EX3DV4 - SN3590 ; ConvF(7.96, 7.96, 7.96) ; Calibrated: 2009/4/28
- Sensor-Surface: 3mm (Mechanical Surface Detection)
- Electronics: DAE4 Sn861 ; Calibrated: 2008/9/22
- Phantom: SAM with CRP ; Type: SAM ; Serial: TP-1485
- Measurement SW: DASY5, V5.0 Build 125 ; SEMCAD X Version 13.4 Build 125

Mid Channel 6 power set 18dBm/Area Scan (5x7x1): Measurement grid: dx=15mm, dy=15mm
Maximum value of SAR (measured) = 0.559 mW/g

Mid Channel 6 power set 18dBm/Zoom Scan (7x7x7) (7x7x7)/Cube 0: Measurement grid:
dx=5mm, dy=5mm, dz=5mm
Reference Value = 8.36 V/m
Peak SAR (extrapolated) = 0.854 W/kg
SAR(1 g) = 0.459 mW/g; SAR(10 g) = 0.244 mW/g
Maximum value of SAR (measured) = 0.560 mW/g

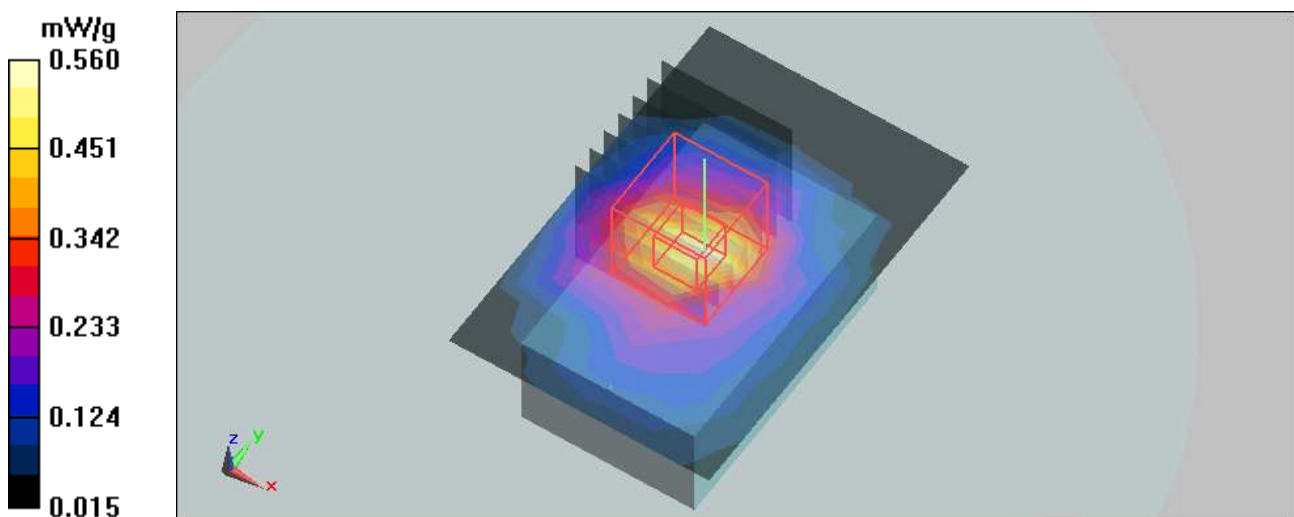

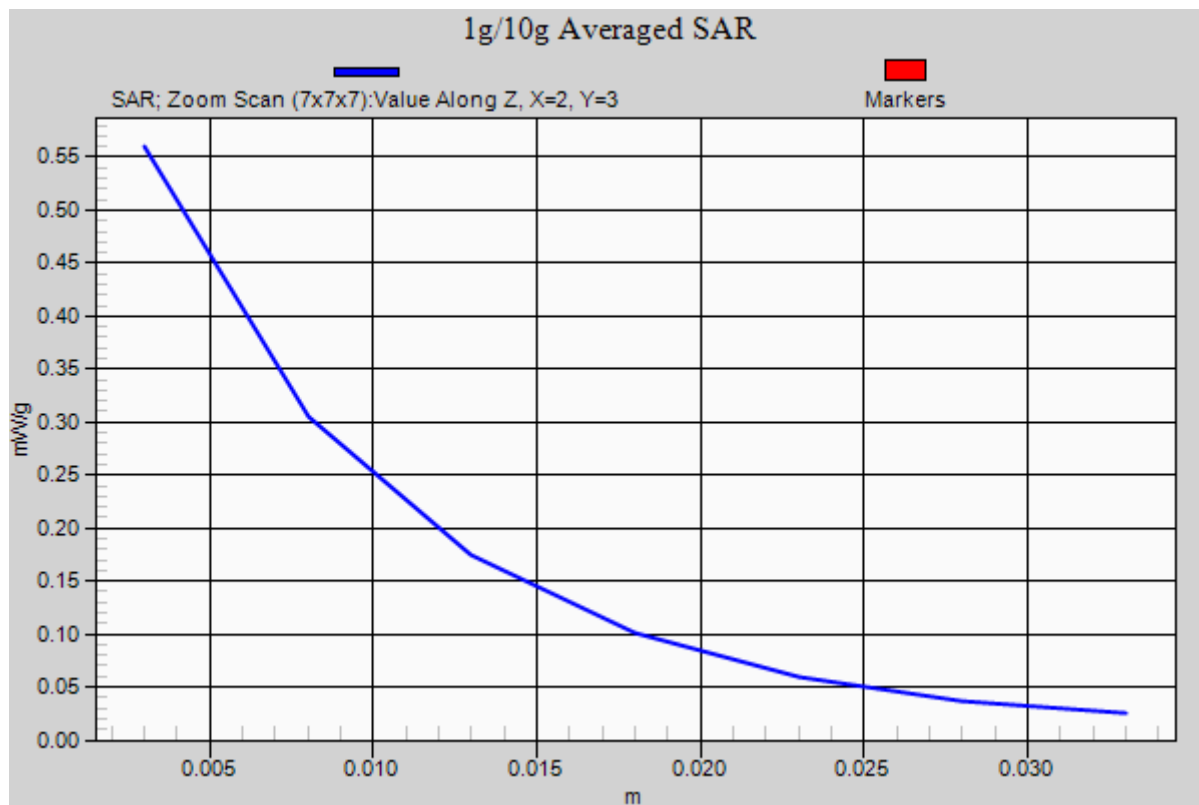

Test Laboratory: Bureau Veritas ADT

M02-Body bottom 11G Ch11

DUT: WiFi Voice Communication Appliance ; Type: CA1060

Communication System: 802.11g ; Frequency: 2462 MHz ; Duty Cycle: 1:1 ; Modulation type: QPSK
Medium: MSL2450 Medium parameters used: $f = 2462$ MHz; $\sigma = 2.01$ mho/m; $\epsilon_r = 53.7$; $\rho = 1000$ kg/m³
Phantom section: Flat Section ; Separation distance : 0 mm (The tip side of the EUT to the Phantom)

DASY5 Configuration:

- Probe: EX3DV4 - SN3590 ; ConvF(7.96, 7.96, 7.96) ; Calibrated: 2009/4/28
- Sensor-Surface: 3mm (Mechanical Surface Detection)
- Electronics: DAE4 Sn861 ; Calibrated: 2008/9/22
- Phantom: SAM with CRP ; Type: SAM ; Serial: TP-1485
- Measurement SW: DASY5, V5.0 Build 125 ; SEMCAD X Version 13.4 Build 125

High Channel 11/Area Scan (5x7x1): Measurement grid: dx=15mm, dy=15mm

Maximum value of SAR (measured) = 0.143 mW/g

High Channel 11/Zoom Scan (7x7x7) (7x7x7)/Cube 0: Measurement grid: dx=5mm, dy=5mm, dz=5mm

Reference Value = 3.59 V/m

Peak SAR (extrapolated) = 0.215 W/kg

SAR(1 g) = **0.119 mW/g**; SAR(10 g) = 0.065 mW/g

Maximum value of SAR (measured) = 0.145 mW/g

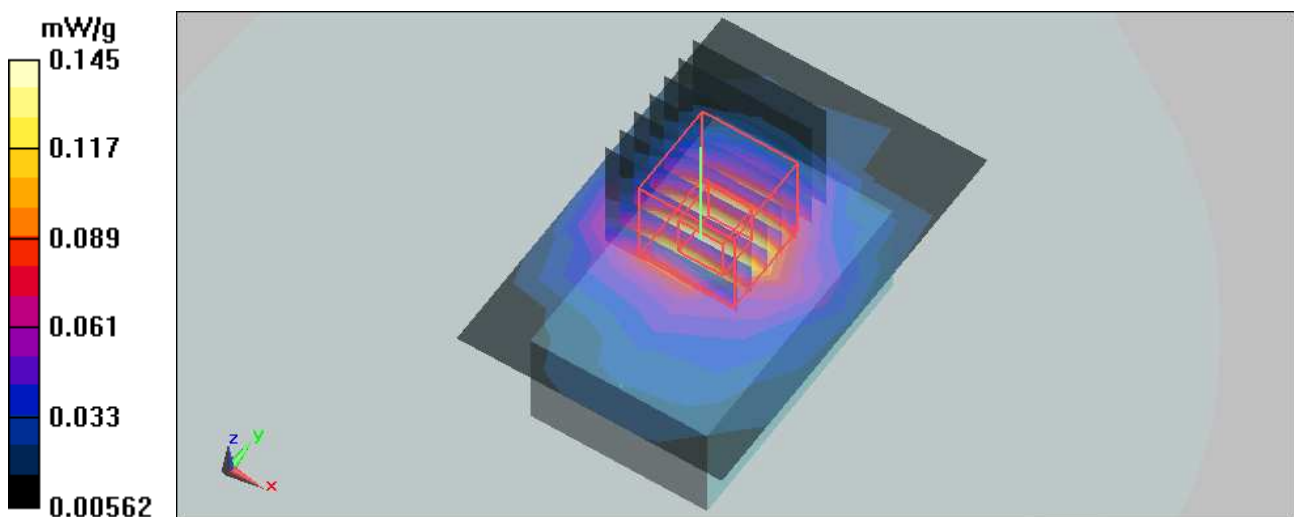

Test Laboratory: Bureau Veritas ADT

M03-Body bottom without earphone 11B Ch6

DUT: WiFi Voice Communication Appliance ; Type: CA1060

Communication System: 802.11b ; Frequency: 2437 MHz ; Duty Cycle: 1:1 ; Modulation type: BPSK
 Medium: MSL2450 Medium parameters used: $f = 2437 \text{ MHz}$; $\sigma = 1.98 \text{ mho/m}$; $\epsilon_r = 53.9$; $\rho = 1000 \text{ kg/m}^3$
 Phantom section: Flat Section ; Separation distance : 0 mm (The tip side of the EUT to the Phantom)

DASY5 Configuration:

- Probe: EX3DV4 - SN3590 ; ConvF(7.96, 7.96, 7.96) ; Calibrated: 2009/4/28
- Sensor-Surface: 3mm (Mechanical Surface Detection)
- Electronics: DAE4 Sn861 ; Calibrated: 2008/9/22
- Phantom: SAM with CRP ; Type: SAM ; Serial: TP-1485
- Measurement SW: DASY5, V5.0 Build 125 ; SEMCAD X Version 13.4 Build 125

Mid Channel 6 power set 18dBm/Area Scan (5x7x1): Measurement grid: dx=15mm, dy=15mm

Maximum value of SAR (measured) = 0.401 mW/g

Mid Channel 6 power set 18dBm/Zoom Scan (7x7x7) (7x7x7)/Cube 0: Measurement grid:

dx=5mm, dy=5mm, dz=5mm

Reference Value = 5.39 V/m

Peak SAR (extrapolated) = 0.593 W/kg

SAR(1 g) = **0.317 mW/g**; SAR(10 g) = 0.174 mW/g

Maximum value of SAR (measured) = 0.385 mW/g

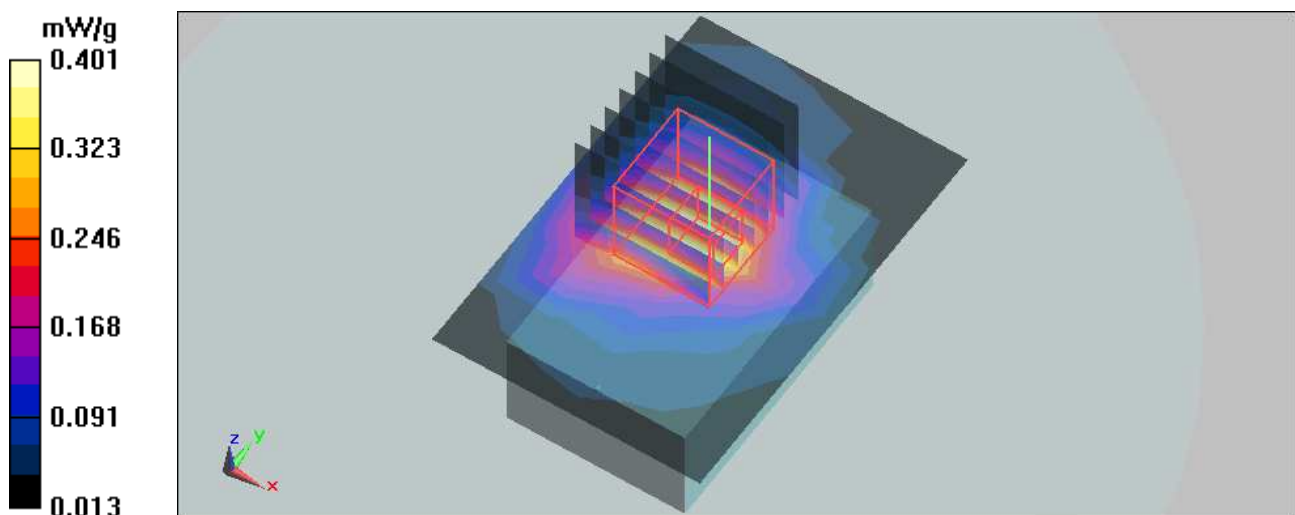

Test Laboratory: Bureau Veritas ADT

M04-Body bottom without earphone 11G Ch6

DUT: WiFi Voice Communication Appliance ; Type: CA1060

Communication System: 802.11g ; Frequency: 2437 MHz ; Duty Cycle: 1:1 ; Modulation type: BPSK
 Medium: MSL2450 Medium parameters used: $f = 2437 \text{ MHz}$; $\sigma = 1.98 \text{ mho/m}$; $\epsilon_r = 53.9$; $\rho = 1000 \text{ kg/m}^3$
 Phantom section: Flat Section ; Separation distance : 0 mm (The tip side of the EUT to the Phantom)

DASY5 Configuration:

- Probe: EX3DV4 - SN3590 ; ConvF(7.96, 7.96, 7.96) ; Calibrated: 2009/4/28
- Sensor-Surface: 3mm (Mechanical Surface Detection)
- Electronics: DAE4 Sn861 ; Calibrated: 2008/9/22
- Phantom: SAM with CRP ; Type: SAM ; Serial: TP-1485
- Measurement SW: DASY5, V5.0 Build 125 ; SEMCAD X Version 13.4 Build 125

Mid Channel 6 power set 18dBm/Area Scan (5x7x1): Measurement grid: $dx=15\text{mm}$, $dy=15\text{mm}$
 Maximum value of SAR (measured) = 0.368 mW/g

Mid Channel 6 power set 18dBm/Zoom Scan (7x7x7) (7x7x7)/Cube 0: Measurement grid:
 $dx=5\text{mm}$, $dy=5\text{mm}$, $dz=5\text{mm}$
 Reference Value = 5.21 V/m
 Peak SAR (extrapolated) = 0.540 W/kg
SAR(1 g) = 0.290 mW/g; SAR(10 g) = 0.159 mW/g
 Maximum value of SAR (measured) = 0.353 mW/g

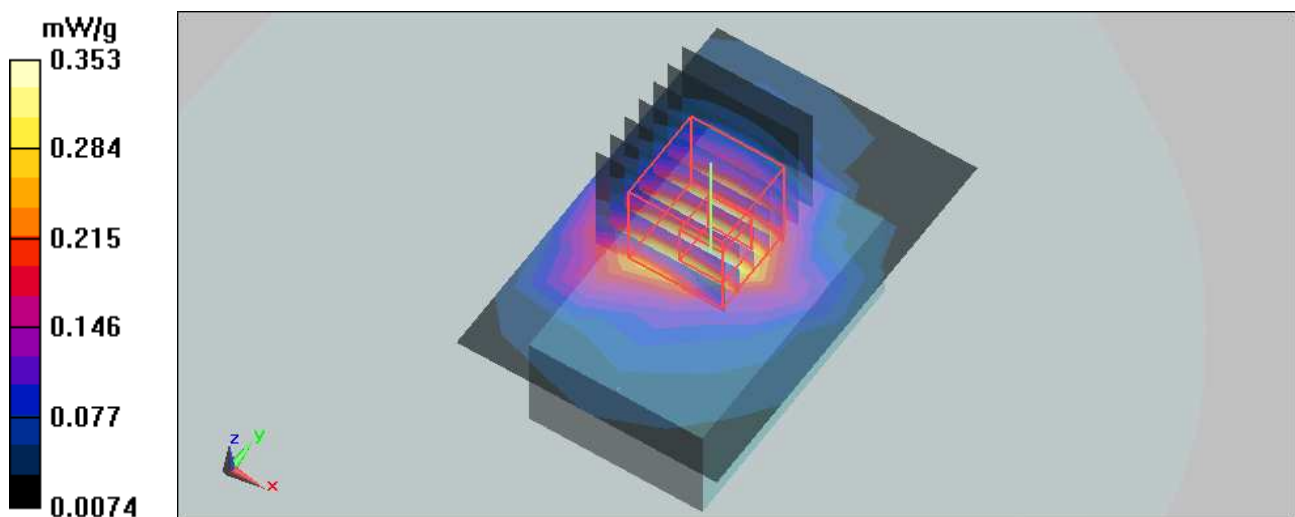

Test Laboratory: Bureau Veritas ADT

M05-Body bottom 11G Ch6

DUT: WiFi Voice Communication Appliance ; Type: CA1060

Communication System: 802.11g ; Frequency: 2437 MHz ; Duty Cycle: 1:1 ; Modulation type: BPSK
Medium: MSL2450 Medium parameters used: $f = 2437$ MHz; $\sigma = 1.98$ mho/m; $\epsilon_r = 53.9$; $\rho = 1000$ kg/m³
Phantom section: Flat Section ; Separation distance : 0 mm (The tip side of the EUT to the Phantom)

DASY5 Configuration:

- Probe: EX3DV4 - SN3590 ; ConvF(7.96, 7.96, 7.96) ; Calibrated: 2009/4/28
- Sensor-Surface: 2mm (Mechanical Surface Detection)
- Electronics: DAE4 Sn861 ; Calibrated: 2008/9/22
- Phantom: SAM with CRP ; Type: SAM ; Serial: TP-1485
- Measurement SW: DASY5, V5.0 Build 125 ; SEMCAD X Version 13.4 Build 125

Mid Channel 6 power set 18dBm/Area Scan (5x7x1): Measurement grid: dx=15mm, dy=15mm
Maximum value of SAR (measured) = 0.474 mW/g

Mid Channel 6 power set 18dBm/Zoom Scan (7x7x7) (13x13x13)/Cube 0: Measurement grid: dx=2.5mm, dy=2.5mm, dz=2.5mm

Reference Value = 6.37 V/m

Peak SAR (extrapolated) = 0.627 W/kg

SAR(1 g) = 0.338 mW/g; SAR(10 g) = 0.179 mW/g

Maximum value of SAR (measured) = 0.478 mW/g

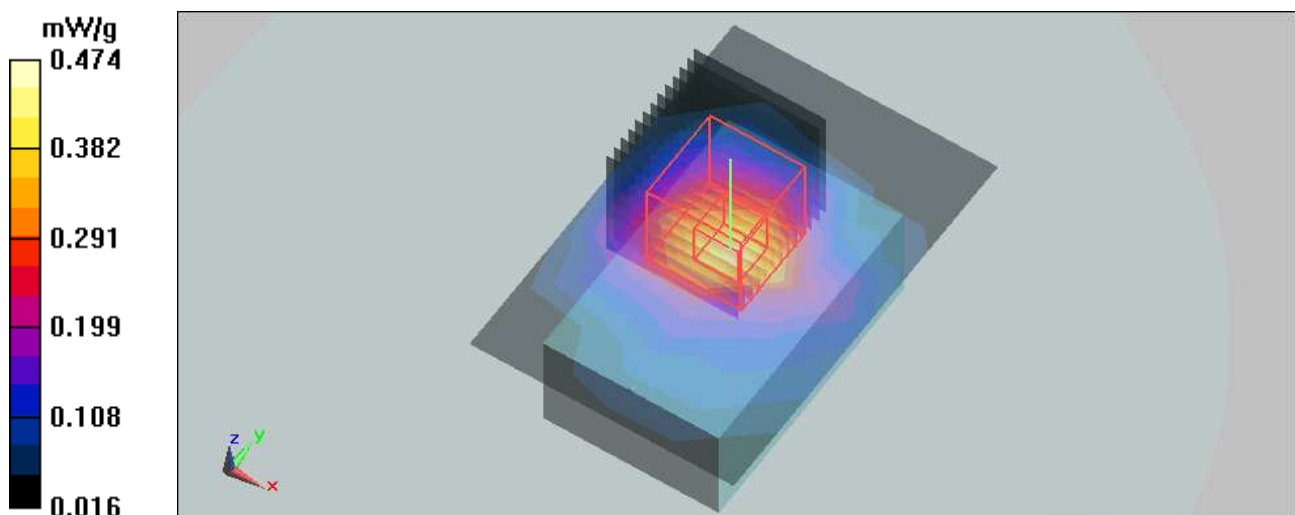

Test Laboratory: Bureau Veritas ADT

System validation MSL 2450MHz

DUT: Dipole 2450 MHz ; Type: D2450V2 ; Serial: 716 ; Test Frequency: 2450 MHz

Communication System: CW ; Frequency: 2450 MHz; Duty Cycle: 1:1; Modulation type: CW

Medium: MSL2450; Medium parameters used: $f = 2450$ MHz; $\sigma = 2$ mho/m; $\epsilon_r = 53.8$; $\rho = 1000$ kg/m³ ;

Liquid level : 151 mm

Phantom section: Flat Section ; Separation distance : 10 mm (The feetpoint of the dipole to the Phantom)

Air temp. : 23.1 degrees ; Liquid temp. : 22.8 degrees

DASY5 Configuration:

- Probe: EX3DV4 - SN3590 ; ConvF(7.96, 7.96, 7.96) ; Calibrated: 2009/4/28

- Sensor-Surface: 3mm (Mechanical Surface Detection)

- Electronics: DAE4 Sn861; Calibrated: 2008/9/22

- Phantom: SAM with CRP; Type: SAM; Serial: TP-1485

- Measurement SW: DASY5, V5.0 Build 125; SEMCAD X Version 13.4 Build 125

d=10mm, Pin=250mW/Area Scan (5x7x1): Measurement grid: dx=15mm, dy=15mm

Maximum value of SAR (measured) = 15.6 mW/g

d=10mm, Pin=250mW/Zoom Scan (7x7x7)/Cube 0: Measurement grid: dx=5mm, dy=5mm, dz=5mm

Reference Value = 89.9 V/m; Power Drift = -0.175 dB

Peak SAR (extrapolated) = 26.4 W/kg

SAR(1 g) = 12.9 mW/g; SAR(10 g) = 5.95 mW/g

Maximum value of SAR (measured) = 16.9 mW/g

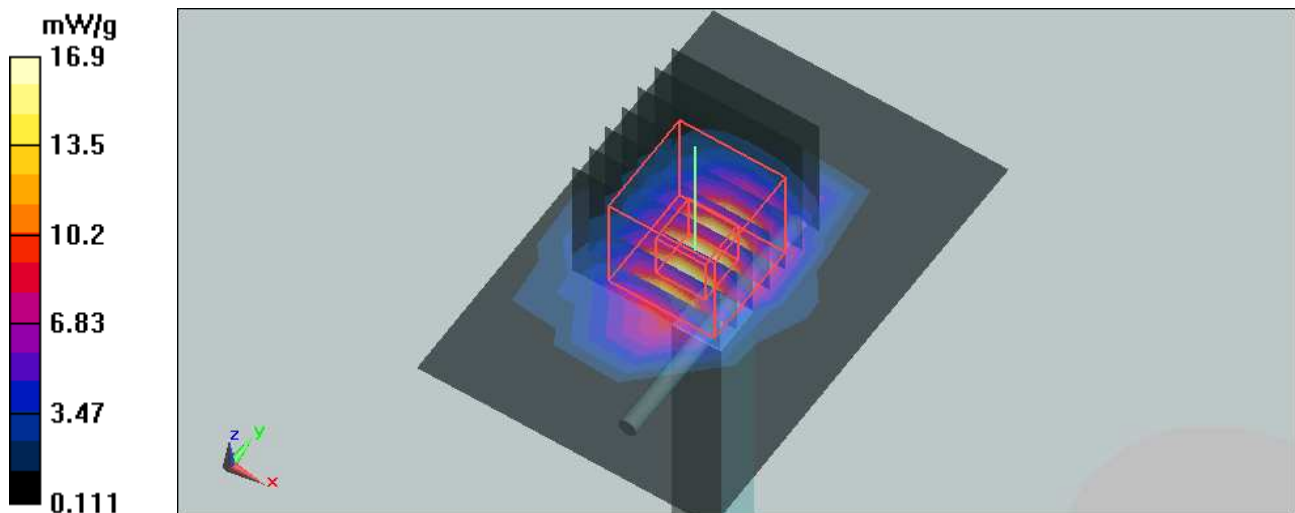

APPENDIX B: BV ADT SAR MEASUREMENT SYSTEM

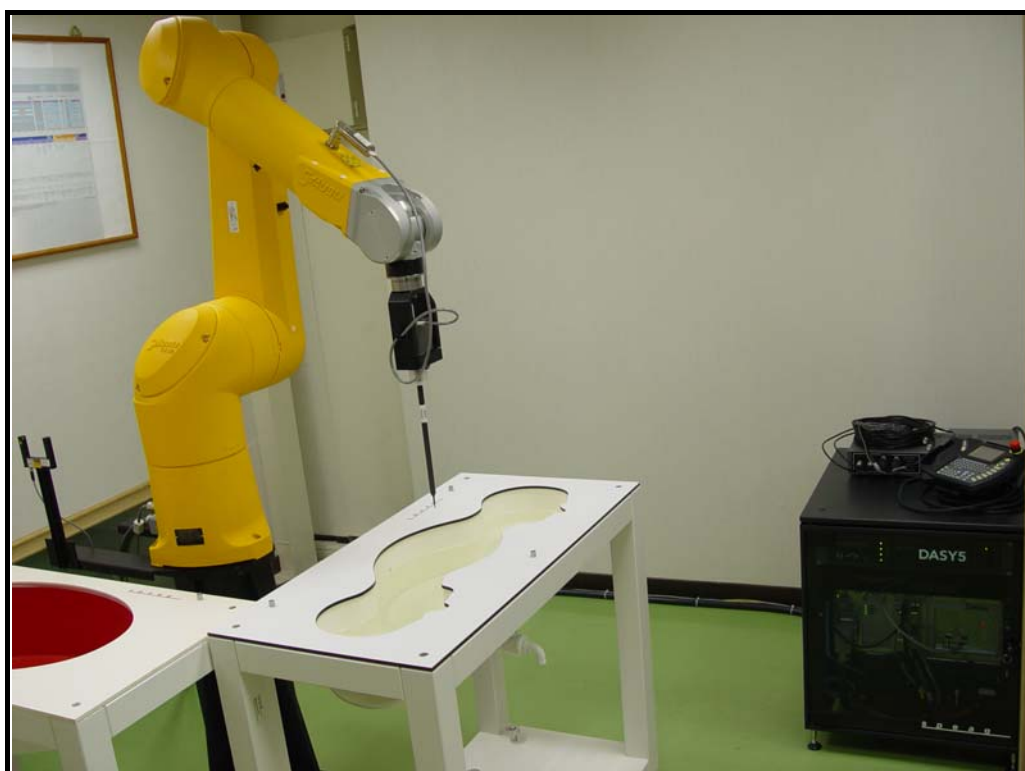

APPENDIX C: PHOTOGRAPHS OF SYSTEM VALIDATION





APPENDIX D: SYSTEM CERTIFICATE & CALIBRATION

D1: PHANTOM

Certificate of Conformity / First Article Inspection

Item	SAM Twin Phantom V4.0
Type No	QD 000 P40 C
Series No	TP-1150 and higher
Manufacturer	SPEAG Zeughausstrasse 43 CH-8004 Zürich Switzerland

Tests

The series production process used allows the limitation to test of first articles. Complete tests were made on the pre-series Type No. QD 000 P40 AA, Serial No. TP-1001 and on the series first article Type No. QD 000 P40 BA, Serial No. TP-1006. Certain parameters have been retested using further series items (called samples) or are tested at each item.

Test	Requirement	Details	Units tested
Dimensions	Compliant with the geometry according to the CAD model.	IT'IS CAD File (*)	First article, Samples
Material thickness of shell	Compliant with the requirements according to the standards	2mm +/- 0.2mm in flat and specific areas of head section	First article, Samples, TP-1314 ff.
Material thickness at ERP	Compliant with the requirements according to the standards	6mm +/- 0.2mm at ERP	First article, All items
Material parameters	Dielectric parameters for required frequencies	300 MHz – 6 GHz: Relative permittivity < 5, Loss tangent < 0.05	Material samples
Material resistivity	The material has been tested to be compatible with the liquids defined in the standards if handled and cleaned according to the instructions. Observe technical Note for material compatibility.	DEGMBE based simulating liquids	Pre-series, First article, Material samples
Sagging	Compliant with the requirements according to the standards. Sagging of the flat section when filled with tissue simulating liquid.	< 1% typical < 0.8% if filled with 155mm of HSL900 and without DUT below	Prototypes, Sample testing

Standards

- [1] CENELEC EN 50361
- [2] IEEE Std 1528-2003
- [3] IEC 62209 Part I
- [4] FCC OET Bulletin 65, Supplement C, Edition 01-01

(*) The IT'IS CAD file is derived from [2] and is also within the tolerance requirements of the shapes of the other documents.

Conformity

Based on the sample tests above, we certify that this item is in compliance with the uncertainty requirements of SAR measurements specified in standards [1] to [4].

Date 07.07.2005

Signature / Stamp



A D T

D2: DOSIMETRIC E-FIELD PROBE



Accredited by the Swiss Accreditation Service (SAS)
The Swiss Accreditation Service is one of the signatories to the EA
Multilateral Agreement for the recognition of calibration certificates

Accreditation No.: **SCS 108**

Client **ADT (Auden)**

Certificate No: **EX3-3590_Apr09**

CALIBRATION CERTIFICATE

Object **EX3DV4 - SN:3590**

Calibration procedure(s) **QA CAL-01.v6, QA CAL-14.v3 and QA CAL-23.v3
Calibration procedure for dosimetric E-field probes**

Calibration date: **April 28, 2009**

Condition of the calibrated item **In Tolerance**

This calibration certificate documents the traceability to national standards, which realize the physical units of measurements (SI).
The measurements and the uncertainties with confidence probability are given on the following pages and are part of the certificate.

All calibrations have been conducted in the closed laboratory facility: environment temperature (22 ± 3)°C and humidity < 70%.

Calibration Equipment used (M&TE critical for calibration)

Primary Standards	ID #	Cal Date (Certificate No.)	Scheduled Calibration
Power meter E4419B	GB41293874	1-Apr-09 (No. 217-01030)	Apr-10
Power sensor E4412A	MY41495277	1-Apr-09 (No. 217-01030)	Apr-10
Power sensor E4412A	MY41498087	1-Apr-09 (No. 217-01030)	Apr-10
Reference 3 dB Attenuator	SN: S5054 (3c)	31-Mar-09 (No. 217-01026)	Mar-10
Reference 20 dB Attenuator	SN: S5086 (20b)	31-Mar-09 (No. 217-01028)	Mar-10
Reference 30 dB Attenuator	SN: S5129 (30b)	31-Mar-09 (No. 217-01027)	Mar-10
Reference Probe ES3DV2	SN: 3013	2-Jan-09 (No. ES3-3013_Jan09)	Jan-10
DAE4	SN: 660	9-Sep-08 (No. DAE4-660_Sep08)	Sep-09
Secondary Standards	ID #	Check Date (in house)	Scheduled Check
RF generator HP 8648C	US3642U01700	4-Aug-99 (in house check Oct-07)	In house check: Oct-09
Network Analyzer HP 8753E	US37390585	18-Oct-01 (in house check Oct-08)	In house check: Oct-09

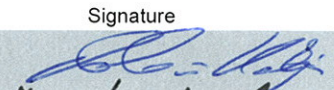
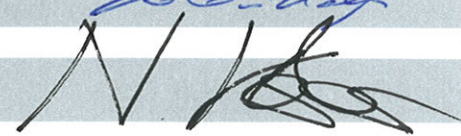
Calibrated by:	Name Katja Pokovic	Function Technical Manager	Signature 
Approved by:	Name Niels Kuster	Function Quality Manager	

Issued: April 28, 2009

This calibration certificate shall not be reproduced except in full without written approval of the laboratory.



Accredited by the Swiss Accreditation Service (SAS)
The Swiss Accreditation Service is one of the signatories to the EA
Multilateral Agreement for the recognition of calibration certificates

Accreditation No.: **SCS 108**

Glossary:

TSL	tissue simulating liquid
$NORM_{x,y,z}$	sensitivity in free space
ConvF	sensitivity in TSL / $NORM_{x,y,z}$
DCP	diode compression point
Polarization φ	φ rotation around probe axis
Polarization ϑ	ϑ rotation around an axis that is in the plane normal to probe axis (at measurement center), i.e., $\vartheta = 0$ is normal to probe axis

Calibration is Performed According to the Following Standards:

- IEEE Std 1528-2003, "IEEE Recommended Practice for Determining the Peak Spatial-Averaged Specific Absorption Rate (SAR) in the Human Head from Wireless Communications Devices: Measurement Techniques", December 2003
- IEC 62209-1, "Procedure to measure the Specific Absorption Rate (SAR) for hand-held devices used in close proximity to the ear (frequency range of 300 MHz to 3 GHz)", February 2005

Methods Applied and Interpretation of Parameters:

- $NORM_{x,y,z}$: Assessed for E-field polarization $\vartheta = 0$ ($f \leq 900$ MHz in TEM-cell; $f > 1800$ MHz: R22 waveguide). $NORM_{x,y,z}$ are only intermediate values, i.e., the uncertainties of $NORM_{x,y,z}$ does not effect the E^2 -field uncertainty inside TSL (see below *ConvF*).
- $NORM(f)_{x,y,z} = NORM_{x,y,z} * frequency_response$ (see Frequency Response Chart). This linearization is implemented in DASY4 software versions later than 4.2. The uncertainty of the frequency response is included in the stated uncertainty of *ConvF*.
- $DCP_{x,y,z}$: DCP are numerical linearization parameters assessed based on the data of power sweep (no uncertainty required). DCP does not depend on frequency nor media.
- ConvF and Boundary Effect Parameters*: Assessed in flat phantom using E-field (or Temperature Transfer Standard for $f \leq 800$ MHz) and inside waveguide using analytical field distributions based on power measurements for $f > 800$ MHz. The same setups are used for assessment of the parameters applied for boundary compensation (alpha, depth) of which typical uncertainty values are given. These parameters are used in DASY4 software to improve probe accuracy close to the boundary. The sensitivity in TSL corresponds to $NORM_{x,y,z} * ConvF$ whereby the uncertainty corresponds to that given for *ConvF*. A frequency dependent *ConvF* is used in DASY version 4.4 and higher which allows extending the validity from ± 50 MHz to ± 100 MHz.
- Spherical isotropy (3D deviation from isotropy)*: in a field of low gradients realized using a flat phantom exposed by a patch antenna.
- Sensor Offset*: The sensor offset corresponds to the offset of virtual measurement center from the probe tip (on probe axis). No tolerance required.

Probe EX3DV4

SN:3590

Manufactured:	March 23, 2009
Calibrated:	April 28, 2009

Calibrated for DASY Systems

(Note: non-compatible with DASY2 system!)

DASY - Parameters of Probe: EX3DV4 SN:3590

Sensitivity in Free Space^A

NormX	0.49 ± 10.1%	$\mu\text{V}/(\text{V}/\text{m})^2$
NormY	0.48 ± 10.1%	$\mu\text{V}/(\text{V}/\text{m})^2$
NormZ	0.50 ± 10.1%	$\mu\text{V}/(\text{V}/\text{m})^2$

Diode Compression^B

DCP X	85 mV
DCP Y	87 mV
DCP Z	88 mV

Sensitivity in Tissue Simulating Liquid (Conversion Factors)

Please see Page 8.

Boundary Effect

TSL **900 MHz** **Typical SAR gradient: 5 % per mm**

Sensor Center to Phantom Surface Distance		2.0 mm	3.0 mm
SAR _{be} [%]	Without Correction Algorithm	9.3	5.6
SAR _{be} [%]	With Correction Algorithm	0.8	0.4

TSL **1750 MHz** **Typical SAR gradient: 10 % per mm**

Sensor Center to Phantom Surface Distance		2.0 mm	3.0 mm
SAR _{be} [%]	Without Correction Algorithm	8.0	5.0
SAR _{be} [%]	With Correction Algorithm	0.9	0.5

Sensor Offset

Probe Tip to Sensor Center **1.0 mm**

The reported uncertainty of measurement is stated as the standard uncertainty of measurement multiplied by the coverage factor k=2, which for a normal distribution corresponds to a coverage probability of approximately 95%.

^A The uncertainties of NormX,Y,Z do not affect the E²-field uncertainty inside TSL (see Page 8).

^B Numerical linearization parameter: uncertainty not required.

Frequency Response of E-Field

(TEM-Cell:ifi110 EXX, Waveguide: R22)

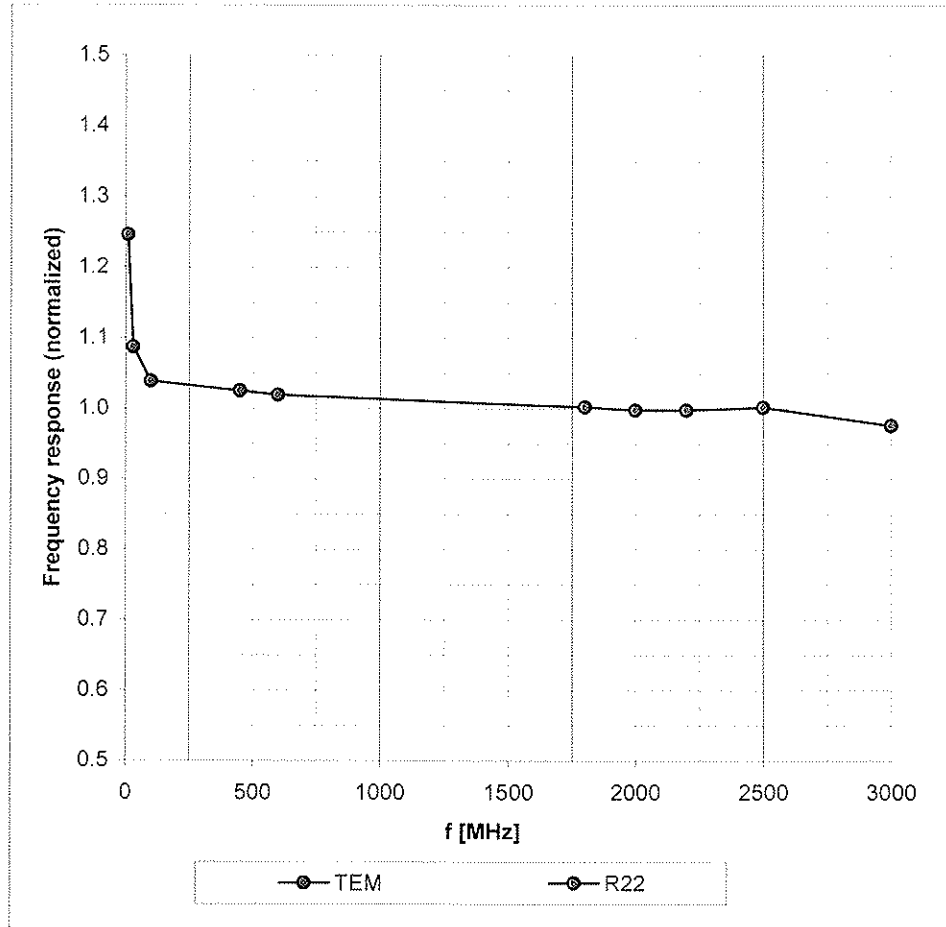

Uncertainty of Frequency Response of E-field: $\pm 6.3\%$ (k=2)

Receiving Pattern (ϕ), $\vartheta = 0^\circ$

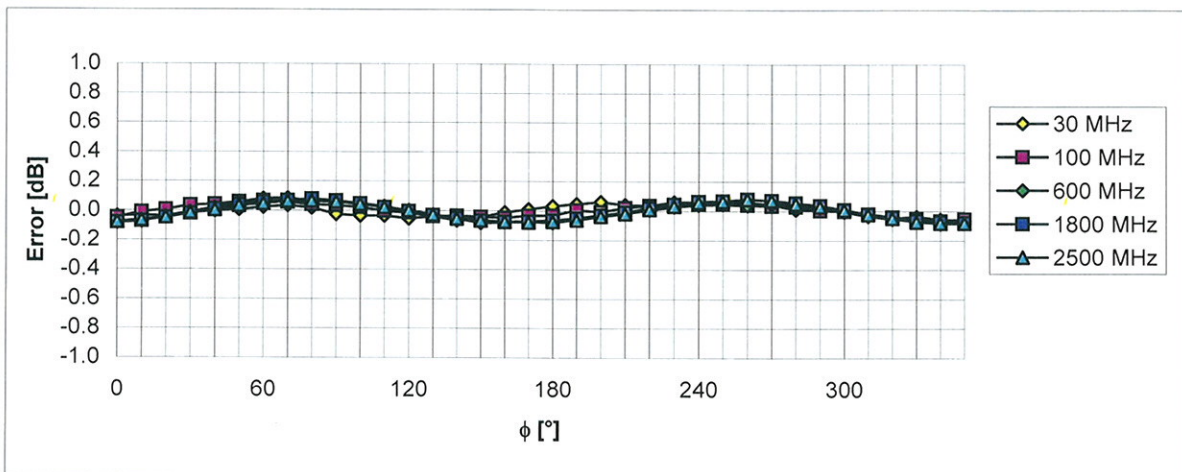
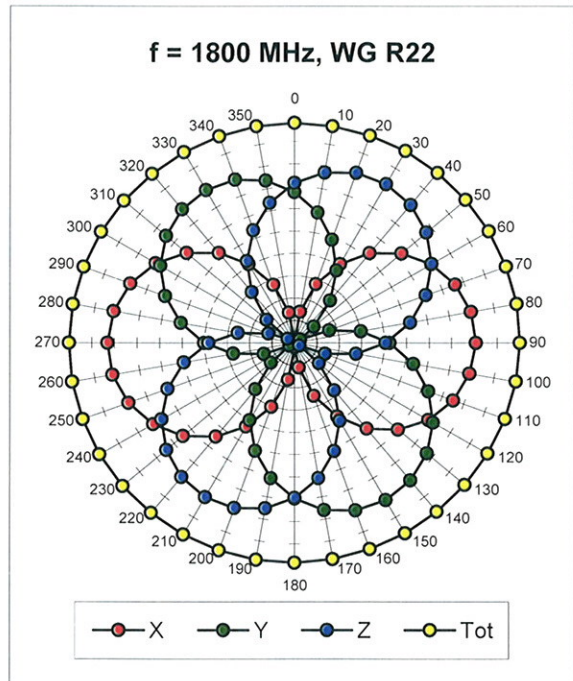
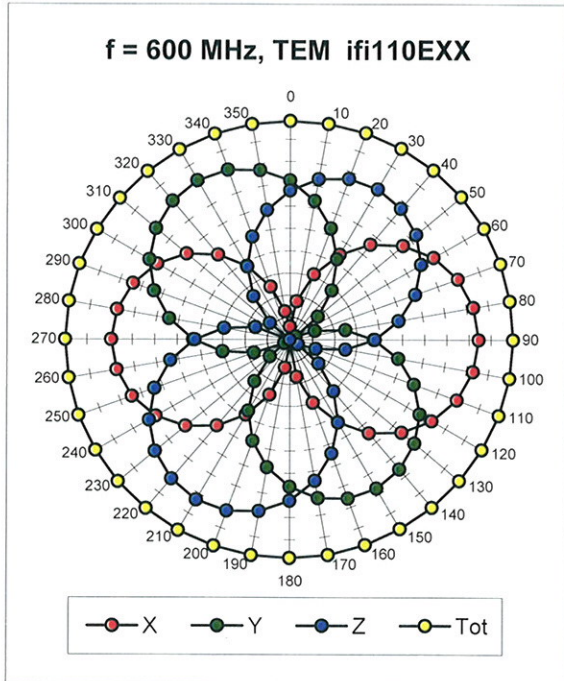

Uncertainty of Axial Isotropy Assessment: $\pm 0.5\%$ ($k=2$)

Dynamic Range $f(SAR_{head})$ (Waveguide R22, $f = 1800$ MHz)

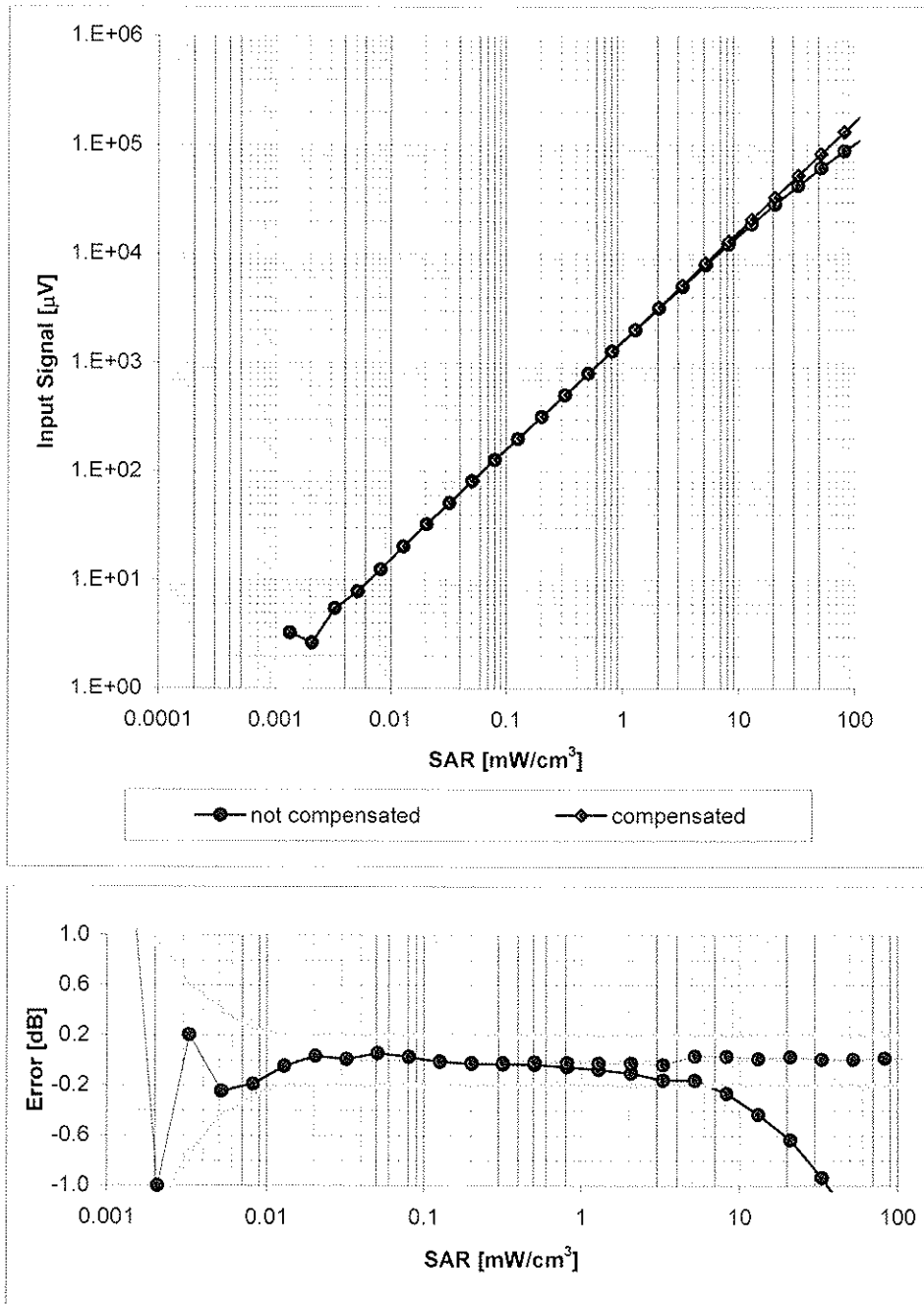

Uncertainty of Linearity Assessment: $\pm 0.6\%$ (k=2)

Conversion Factor Assessment

f [MHz]	Validity [MHz] ^c	TSL	Permittivity	Conductivity	Alpha	Depth	ConvF Uncertainty
900	± 50 / ± 100	Head	41.5 ± 5%	0.97 ± 5%	0.72	0.63	9.79 ± 11.0% (k=2)
1750	± 50 / ± 100	Head	40.1 ± 5%	1.37 ± 5%	0.70	0.58	8.82 ± 11.0% (k=2)
1950	± 50 / ± 100	Head	40.0 ± 5%	1.40 ± 5%	0.63	0.61	8.39 ± 11.0% (k=2)
2300	± 50 / ± 100	Head	39.5 ± 5%	1.67 ± 5%	0.70	0.57	8.28 ± 11.0% (k=2)
2450	± 50 / ± 100	Head	39.2 ± 5%	1.80 ± 5%	0.61	0.61	7.88 ± 11.0% (k=2)
2600	± 50 / ± 100	Head	39.0 ± 5%	1.96 ± 5%	0.40	0.76	7.85 ± 11.0% (k=2)
3500	± 50 / ± 100	Head	37.9 ± 5%	2.91 ± 5%	0.33	1.10	7.15 ± 13.1% (k=2)
4950	± 50 / ± 100	Head	36.3 ± 5%	4.40 ± 5%	0.42	1.70	5.43 ± 13.1% (k=2)
5200	± 50 / ± 100	Head	36.0 ± 5%	4.66 ± 5%	0.45	1.70	5.34 ± 13.1% (k=2)
5300	± 50 / ± 100	Head	35.9 ± 5%	4.76 ± 5%	0.45	1.70	4.90 ± 13.1% (k=2)
5500	± 50 / ± 100	Head	35.6 ± 5%	4.96 ± 5%	0.50	1.70	4.79 ± 13.1% (k=2)
5600	± 50 / ± 100	Head	35.5 ± 5%	5.07 ± 5%	0.50	1.70	4.61 ± 13.1% (k=2)
5800	± 50 / ± 100	Head	35.3 ± 5%	5.27 ± 5%	0.50	1.70	4.60 ± 13.1% (k=2)
900	± 50 / ± 100	Body	55.0 ± 5%	1.05 ± 5%	0.49	0.74	9.93 ± 11.0% (k=2)
1750	± 50 / ± 100	Body	53.4 ± 5%	1.49 ± 5%	0.59	0.68	8.62 ± 11.0% (k=2)
1950	± 50 / ± 100	Body	53.3 ± 5%	1.52 ± 5%	0.47	0.77	8.39 ± 11.0% (k=2)
2300	± 50 / ± 100	Body	52.8 ± 5%	1.85 ± 5%	0.38	0.86	8.05 ± 11.0% (k=2)
2450	± 50 / ± 100	Body	52.7 ± 5%	1.95 ± 5%	0.40	0.77	7.96 ± 11.0% (k=2)
2600	± 50 / ± 100	Body	52.5 ± 5%	2.16 ± 5%	0.34	0.86	7.84 ± 11.0% (k=2)
3500	± 50 / ± 100	Body	51.3 ± 5%	3.31 ± 5%	0.33	1.26	6.75 ± 13.1% (k=2)
4950	± 50 / ± 100	Body	49.4 ± 5%	5.01 ± 5%	0.40	1.80	5.13 ± 13.1% (k=2)
5200	± 50 / ± 100	Body	49.0 ± 5%	5.30 ± 5%	0.50	1.80	5.01 ± 13.1% (k=2)
5300	± 50 / ± 100	Body	48.5 ± 5%	5.42 ± 5%	0.50	1.80	4.72 ± 13.1% (k=2)
5500	± 50 / ± 100	Body	48.6 ± 5%	5.65 ± 5%	0.56	1.80	4.42 ± 13.1% (k=2)
5600	± 50 / ± 100	Body	48.5 ± 5%	5.77 ± 5%	0.55	1.80	4.07 ± 13.1% (k=2)
5800	± 50 / ± 100	Body	48.2 ± 5%	6.00 ± 5%	0.60	1.80	4.62 ± 13.1% (k=2)

^c The validity of ± 100 MHz only applies for DASY v4.4 and higher (see Page 2). The uncertainty is the RSS of the ConvF uncertainty at calibration frequency and the uncertainty for the indicated frequency band.

Deviation from Isotropy in HSL

Error (ϕ, ϑ), $f = 900$ MHz

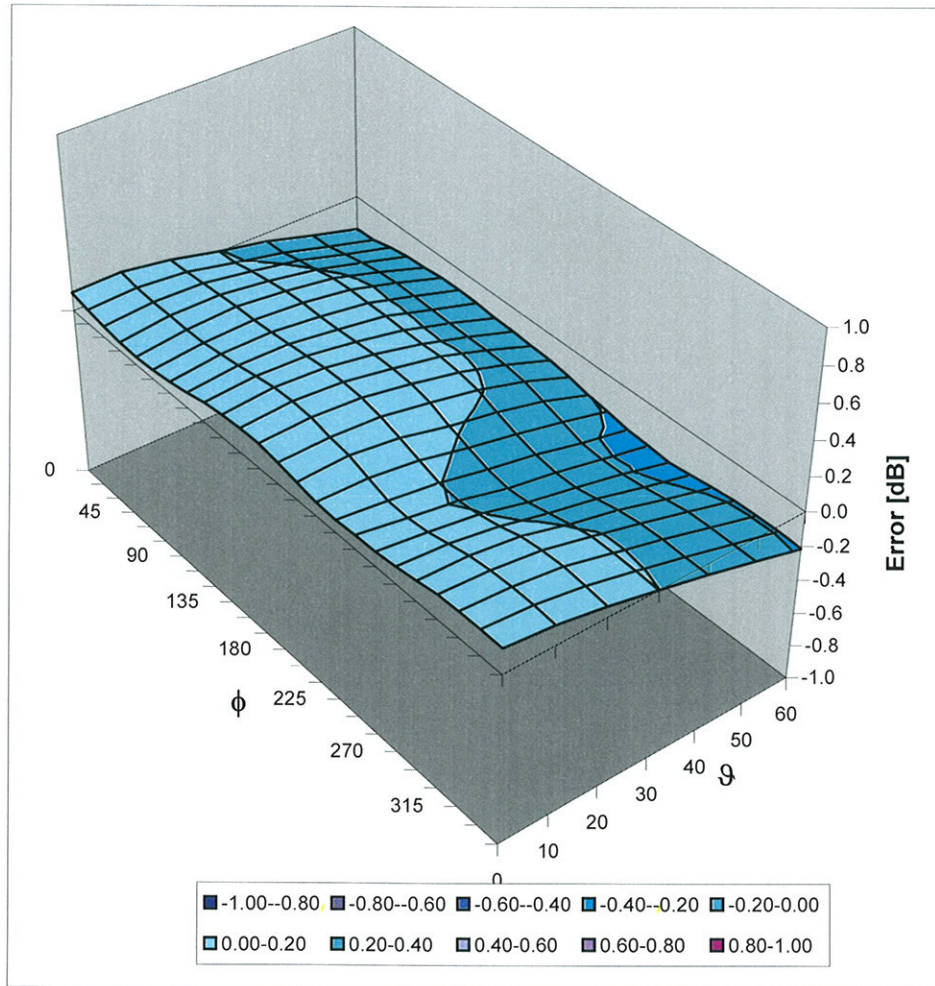

Uncertainty of Spherical Isotropy Assessment: $\pm 2.6\%$ ($k=2$)