

# ATR7000

Advanced Array RFID Reader

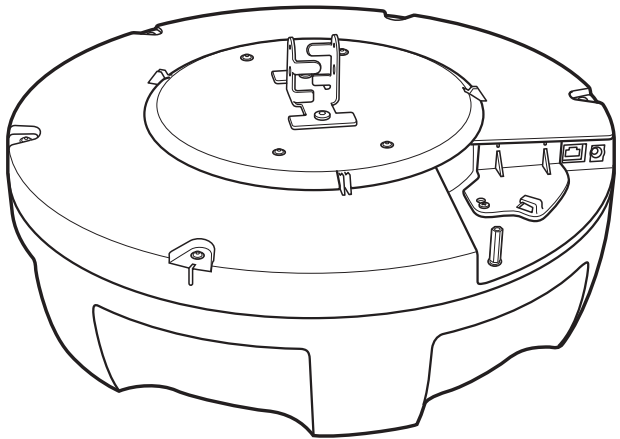

**Quick Reference Guide**



**ZEBRA**

---

## Warranty

For the complete Zebra hardware product warranty statement, go to: [www.zebra.com/warranty](http://www.zebra.com/warranty).

---

## Service Information

If you have a problem using the equipment, contact your facility's Technical or Systems Support. If there is a problem with the equipment, they will contact the Zebra Support at: <http://www.zebra.com/support>.

For the latest version of this guide go to: [www.zebra.com/support](http://www.zebra.com/support).

---

## Software Support

Zebra wants to ensure that customers have the latest release of entitled software at the time of product purchase.

To confirm that your Zebra device shipped with the latest release of entitled software, visit: [www.zebra.com/support](http://www.zebra.com/support). Check for the latest software from *Software Downloads > Product Line/Product > Go*.

If your device does not have the latest entitled software release as of your product purchase date, please e-mail a request to Zebra at: [entitlementservices@zebra.com](mailto:entitlementservices@zebra.com).

You must include the following essential device information with your request:

- Model number
- Serial number
- Proof of purchase
- Title of the software download you are requesting.

If it is determined by Zebra that your device is entitled to the latest software release, you will receive an e-mail containing a link directing you to a Zebra web site to download the appropriate software.

---

## Related Information

The following documents provide more information about the RFID reader:

- *ATR7000 Advanced Array RFID Reader Integration Guide* (p/n MN-003191-xx)
- *RFID Reader Software Interface Control Guide* (p/n 72E-131718-xx)
- *RFID Demo Applications User Guide* (p/n 72E-160038-xx)

For the latest version of this guide and all guides, go to: <http://www.zebra.com/support>.

---

## Introduction

The ATR7000 reader provides real-time, seamless tag processing for EPC Class1 Gen2V2 compliant tags. This Quick Reference Guide provides information about installing and connecting the reader. For more information refer to the *ATR7000 Advanced Array RFID Reader Integration Guide*, available at: [www.zebra.com/support](http://www.zebra.com/support).

---

## Reader Installation

1. Unpack the reader.
2. Place the reader on a desktop.
3. Connect the Ethernet cable to the Ethernet port.

✓ **NOTE** Connecting the reader to a subnet that supports DHCP is recommended. This installation procedure is not guaranteed to work if DHCP is disabled in the reader and if the reader is connected directly to a PC.

4. If not using a PoE+ Ethernet cable, connect a +24V DC power supply to an AC power outlet, and the DC output end of the power supply to the power port labeled on the unit.

The green power LED remains lit after successful installation.

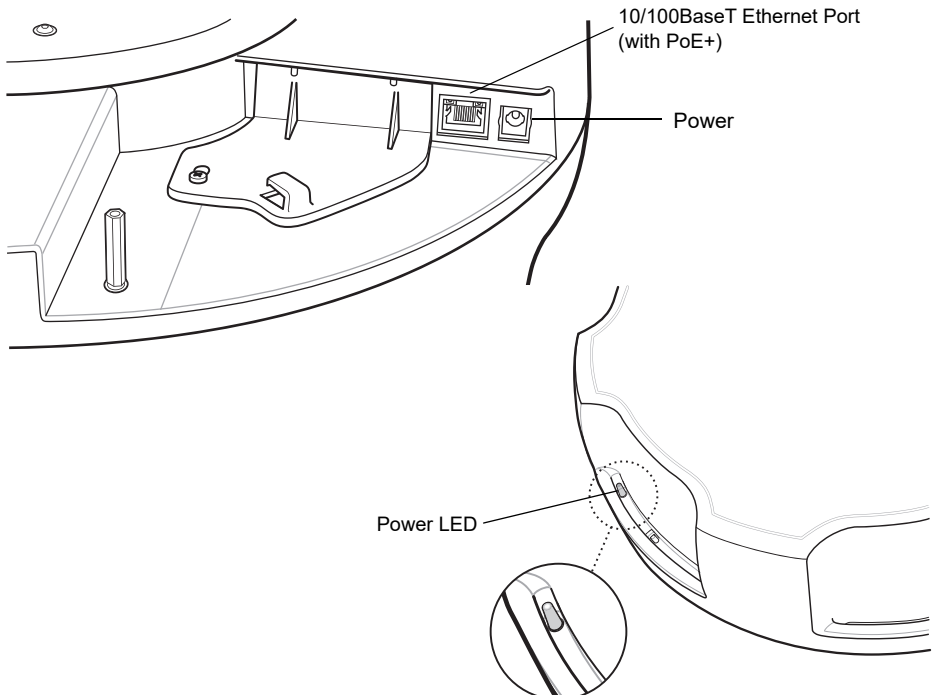

## Connecting to the Reader

To connect via host name:

1. Open a browser. Recommended browsers are IE11 (disabling Compatibility View is recommended), Chrome v58, and FireFox 54.
2. In the browser, enter the host name followed by the last three octets of the MAC, provided on a label on the reader. For example, for a MAC address of 0023683BA63A, enter **http://ATR70003BA63A**.
3. Press **Enter**. The **User Login** window appears and the reader is ready.



**NOTE** Connect the reader to a network that supports host name registration and lookup to ensure the network can access the reader using the host name. For instance, some networks can register host names through DHCP. When first connecting to the reader, it is recommended to keep DHCP enabled in both the PC and in the reader, although it is not guaranteed that host name will work all the time.

---

## Regulatory Information

This device is approved under Zebra Technologies Corporation.

This guide applies to Model Number ATR7000.

All Zebra devices are designed to be compliant with the rules and regulations in the locations they are sold and will be labeled as required.

Local language translations are available at the following website: [www.zebra.com/support](http://www.zebra.com/support).

Any changes or modifications to Zebra equipment not expressly approved by Zebra could void the user's authority to operate the equipment.

Declared maximum operating temperature: 55°C.

---

## Health and Safety Recommendations



### Warnings for Use of Wireless Devices

Please observe all warning notices with regard to the usage of wireless devices.

### Potentially Hazardous Atmospheres - Fixed Installations

You are reminded of the need to observe restrictions on the use of radio devices in fuel depots, chemical plants etc., and areas where the air contains chemicals or particles such as grain, dust, or metal powders.

## RF Exposure Guidelines

### Safety Information

#### *Reducing RF Exposure - Use Properly*

Only operate the device in accordance with the instructions supplied.

#### *International*

The device complies with internationally recognized standards covering human exposure to electromagnetic fields from radio devices. For information on 'International' human exposure to electromagnetic fields, refer to the Zebra Declaration of Conformity (DoC) at [www.zebra.com/doc](http://www.zebra.com/doc).

For further information on the safety of RF energy from wireless devices, see [www.zebra.com/responsibility](http://www.zebra.com/responsibility) located under Corporate Responsibility.

#### *US and Canada*

Statement of Compliance

The full text of the US/Canada Declaration of Conformity is available at the following Internet address:  
[www.zebra.com/doc](http://www.zebra.com/doc)

#### **Remote and Standalone Antenna Configurations**

To comply with FCC RF exposure requirements, antennas that are mounted externally at remote locations or operating near users at stand-alone desktop or similar configurations must operate with a minimum separation distance of 22 cm from all persons.

#### **Industry Canada**

This equipment complies with RF Exposure limits established for an uncontrolled environment (General Population). This equipment should be installed and operated in such a way that a separation greater than 33 centimeters is maintained between the transmitter's radiating structure(s) and the body of the users or nearby persons.

#### **Déclaration d'exposition aux radiations**

Cet équipement est conforme aux limites d'exposition aux RF établies pour un environnement non contrôlé (population générale). Cet équipement doit être installé et utilisé de manière à maintenir une distance de séparation supérieure à 33 centimètres entre la (les) structure (s) rayonnante (s) de l'émetteur et le corps de l'utilisateur ou des personnes à proximité.

### **Power Supply**

This device must be powered from a POE 802.3at compliant power source (POE+) which has been certified by the appropriate agencies, or by a Zebra approved NRTL Certified ITE (LPS/SELV) power supply with electrical ratings: Output 24 VDC, min 3.25 A, with a recommended ambient temperature greater than 55°C. Use of alternative power supply will invalidate any approvals given to this unit and may be dangerous.

---

## Radio Frequency Interference Requirements - FCC



Note: This equipment has been tested and found to comply with the limits for a Class B digital device, pursuant to Part 15 of the FCC rules. These limits are designed to provide reasonable protection against harmful interference in a residential installation. This equipment generates, uses and can radiate radio frequency energy and, if not installed and used in accordance with the instructions, may cause harmful interference to radio communications. However, there is no guarantee that interference will not occur in a particular installation. If this equipment does cause harmful interference to radio or television reception, which can be determined by turning the equipment off and on, the user is encouraged to try to correct the interference by one or more of the following measures:

- Reorient or relocate the receiving antenna.
- Increase the separation between the equipment and receiver.
- Connect the equipment into an outlet on a circuit different from that to which the receiver is connected.
- Consult the dealer or an experienced radio/TV technician for help.

## Radio Transmitters (Part 15)

This device complies with Part 15 of the FCC Rules. Operation is subject to the following two conditions: (1) this device may not cause harmful interference, and (2) this device must accept any interference received including interference that may cause undesired operation.

---

## Radio Frequency Interference Requirements - Canada

Innovation, Science and Economic Development Canada ICES-003 Compliance Label: CAN ICES-3 (B)/NMB-3(B)

## Radio Transmitters

This device complies with Industry Canada's licence-exempt RSSs. Operation is subject to the following two conditions: (1) This device may not cause interference; and (2) This device must accept any interference, including interference that may cause undesired operation of the device.

Le présent appareil est conforme aux CNR d'Industrie Canada applicables aux appareils radio exempts de licence. L'exploitation est autorisée aux deux conditions suivantes: (1) l'appareil ne doit pas produire de brouillage, et (2) l'utilisateur de l'appareil doit accepter tout brouillage radio électrique subi même si le brouillage est susceptible d'en compromettre le fonctionnement.





[www.zebra.com](http://www.zebra.com)

---

© 2018 ZIH Corp and/or its affiliates. All rights reserved. Zebra and the stylized Zebra head are trademarks of ZIH Corp., registered in many jurisdictions worldwide. All other trademarks are the property of their respective owners.



MN-003193-01 Rev. A - 8/18