



# FCC TEST REPORT (WLAN 15.407)

**REPORT NO.:** RF140702E01-1

**MODEL NO.:** AP-7502

**FCC ID:** UZ7AP7502

**RECEIVED:** July 02, 2014

**TESTED:** July 24 to Aug. 04, 2014

**ISSUED:** Aug. 12, 2014

**APPLICANT:** Motorola Solutions, Inc.

**ADDRESS:** One Motorola Plaza Holtsville, NY 11742-1300

**MANUFACTURER:** Accton Technology Corporation

**ADDRESS:** Creation 3rd Rd., Science-based Industrial  
Park, Hsinchu 300, Taiwan, R.O.C.

**ISSUED BY:** Bureau Veritas Consumer Products Services (H.K.) Ltd.,  
Taoyuan Branch Hsin Chu Laboratory

**LAB ADDRESS :** No. 81-1, Lu Liao Keng, 9th Ling, Wu Lung Tsuen,  
Chiung Lin Hsiang, Hsin Chu Hsien 307, Taiwan, R.O.C.

**TEST LOCATION (1):** No. 81-1, Lu Liao Keng, 9th Ling, Wu Lung Tsuen,  
Chiung Lin Hsiang, Hsin Chu Hsien 307, Taiwan, R.O.C.

**TEST LOCATION (2):** No. 49, Ln. 206, Wende Rd., Shangshan Tsuen, Chiung  
Lin Hsiang, Hsin Chu Hsien 307, Taiwan, R.O.C.

This report should not be used by the client to claim product certification, approval, or endorsement by TAF or any government agencies.



This report is for your exclusive use. Any copying or replication of this report to or for any other person or entity, or use of our name or trademark, is permitted only with our prior written permission. This report sets forth our findings solely with respect to the test samples identified herein. The results set forth in this report are not indicative or representative of the quality or characteristics of the lot from which a test sample was taken or any similar or identical product unless specifically and expressly noted. Our report includes all of the tests requested by you and the results thereof based upon the information that you provided to us. You have 60 days from date of issuance of this report to notify us of any material error or omission caused by our negligence, provided, however, that such notice shall be in writing and shall specifically address the issue you wish to raise. A failure to raise such issue within the prescribed time shall constitute your unqualified acceptance of the completeness of this report, the tests conducted and the correctness of the report contents. Unless specific mention, the uncertainty of measurement has been explicitly taken into account to declare the compliance or non-compliance to the specification



A D T

## Table of Contents

RELEASE CONTROL RECORD.....	4
1. CERTIFICATION.....	5
2. SUMMARY OF TEST RESULTS.....	6
2.1 MEASUREMENT UNCERTAINTY.....	7
3. GENERAL INFORMATION.....	8
3.1 GENERAL DESCRIPTION OF EUT (WLAN).....	8
3.2 DESCRIPTION OF TEST MODES.....	11
3.2.1 TEST MODE APPLICABILITY AND TESTED CHANNEL DETAIL.....	12
3.3 GENERAL DESCRIPTION OF APPLIED STANDARDS.....	14
3.4 DUTY CYCLE OF TEST SIGNAL.....	15
3.5 DESCRIPTION OF SUPPORT UNITS.....	16
3.6 CONFIGURATION OF SYSTEM UNDER TEST.....	17
4. TEST TYPES AND RESULTS.....	19
4.1 CONDUCTED EMISSION MEASUREMENT.....	19
4.1.1 LIMITS OF CONDUCTED EMISSION MEASUREMENT.....	19
4.1.2 TEST INSTRUMENTS.....	19
4.1.3 TEST PROCEDURES.....	20
4.1.4 DEVIATION FROM TEST STANDARD.....	20
4.1.5 TEST SETUP.....	20
4.1.6 EUT OPERATING CONDITIONS.....	21
4.1.7 TEST RESULTS (MODE 1).....	22
4.1.8 TEST RESULTS (MODE 2).....	24
4.2 RADIATED EMISSION AND BANDEDGE MEASUREMENT.....	26
4.2.1 LIMITS OF RADIATED EMISSION AND BANDEDGE MEASUREMENT.....	26
4.2.2 LIMITS OF UNWANTED EMISSION OUT OF THE RESTRICTED BANDS.....	27
4.2.3 TEST INSTRUMENTS.....	28
4.2.4 TEST PROCEDURES.....	29
4.2.5 DEVIATION FROM TEST STANDARD.....	29
4.2.6 TEST SETUP.....	30
4.2.7 EUT OPERATING CONDITION.....	30
4.2.8 TEST RESULTS.....	31
4.3 TRANSMIT POWER MEASUREMENT.....	67
4.3.1 LIMITS OF TRANSMIT POWER MEASUREMENT.....	67
4.3.2 TEST INSTRUMENTS.....	68
4.3.3 TEST PROCEDURE.....	68
4.3.4 DEVIATION FROM TEST STANDARD.....	69
4.3.5 TEST SETUP.....	69
4.3.6 EUT OPERATING CONDITIONS.....	69
4.3.7 TEST RESULTS.....	70
4.4 PEAK POWER SPECTRAL DENSITY MEASUREMENT.....	94
4.4.1 LIMITS OF PEAK POWER SPECTRAL DENSITY MEASUREMENT.....	94
4.4.2 TEST INSTRUMENTS.....	94
4.4.3 TEST PROCEDURES.....	95



A D T

4.4.4	DEVIATION FROM TEST STANDARD .....	96
4.4.5	TEST SETUP .....	96
4.4.6	EUT OPERATING CONDITIONS .....	96
4.4.7	TEST RESULTS .....	97
4.5	FREQUENCY STABILITY .....	102
4.5.1	LIMITS OF FREQUENCY STABILITY MEASUREMENT .....	102
4.5.2	TEST INSTRUMENTS .....	102
4.5.3	TEST PROCEDURE .....	102
4.5.4	DEVIATION FROM TEST STANDARD .....	103
4.5.5	TEST SETUP .....	103
4.5.6	EUT OPERATING CONDITION .....	103
4.5.7	TEST RESULTS .....	104
4.6	6dB BANDWIDTH MEASUREMENT .....	105
4.6.1	LIMITS OF 6DB BANDWIDTH MEASUREMENT .....	105
4.6.2	TEST INSTRUMENTS .....	105
4.6.3	TEST PROCEDURE .....	105
4.6.4	DEVIATION FROM TEST STANDARD .....	105
4.6.5	TEST SETUP .....	105
4.6.6	EUT OPERATING CONDITIONS .....	105
4.6.7	TEST RESULTS .....	106
5.	PHOTOGRAPHS OF THE TEST CONFIGURATION .....	108
6.	INFORMATION ON THE TESTING LABORATORIES .....	109
7.	APPENDIX A - MODIFICATIONS RECORDERS FOR ENGINEERING CHANGES TO THE EUT BY THE LAB .....	110



A D T

## RELEASE CONTROL RECORD

ISSUE NO.	REASON FOR CHANGE	DATE ISSUED
RF140702E01-1	Original release	Aug. 12, 2014



A D T

## 1. CERTIFICATION

**PRODUCT:** Dual Radio Wallplate AP  
**BRAND NAME:** Motorola  
**MODEL NO.:** AP-7502  
**TEST SAMPLE:** ENGINEERING SAMPLE  
**APPLICANT:** Motorola Solutions, Inc.  
**TESTED:** July 24 to Aug. 04, 2014  
**STANDARDS:** **FCC Part 15, Subpart E (Section 15.407)**  
ANSI C63.10-2009

The above equipment (Model: AP-7502) has been tested by **Bureau Veritas Consumer Products Services (H.K.) Ltd., Taoyuan Branch**, and found compliance with the requirement of the above standards. The test record, data evaluation & Equipment Under Test (EUT) configurations represented herein are true and accurate accounts of the measurements of the sample's EMC characteristics under the conditions specified in this report.

**PREPARED BY** :  , **DATE:** Aug. 12, 2014  
( Elsie Hsu, Specialist )

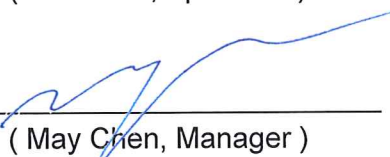
**APPROVED BY** :  , **DATE:** Aug. 12, 2014  
( May Chen, Manager )



A D T

## 2. SUMMARY OF TEST RESULTS

The EUT has been tested according to the following specifications:

APPLIED STANDARD: FCC PART 15, SUBPART E (SECTION 15.407)			
STANDARD SECTION	TEST TYPE	RESULT	REMARK
15.407(b)(6)	AC Power Conducted Emission	PASS	Meet the requirement of limit. Minimum passing margin is -9.40dB at 0.41172MHz
15.407 (b)(1/2/3/4/6)	Radiated Emissions & Band Edge Measurement	PASS	Meet the requirement of limit. Minimum passing margin is -0.9dB at 5150.00MHz.
15.407(a/1/2/3)	Transmit Power	PASS	Meet the requirement of limit.
15.407(a/1/2/3)	Peak Power Spectral Density	PASS	Meet the requirement of limit.
15.407(e)	6dB bandwidth	PASS	Meet the requirement of limit. (U-NII-3 Band only)
15.407(g)	Frequency Stability	PASS	Meet the requirement of limit.
15.203	Antenna Requirement	PASS	Antenna connector is I-Pex not a standard connector.

**NOTE: 1.** For WLAN: The EUT was operating in 2400 ~ 2483.5MHz, 5.15~5.25GHz and 5.725~5.850GHz frequencies band. This report was recorded the RF parameters including 5.15~5.25GHz and 5.725~5.850GHz. For the 2400 ~ 2483.5MHz RF parameters was recorded in another test report.



A D T

## 2.1 MEASUREMENT UNCERTAINTY

Where relevant, the following measurement uncertainty levels have been estimated for tests performed on the EUT as specified in CISPR 16-4-2:

This uncertainty represents an expanded uncertainty expressed at approximately the 95% confidence level using a coverage factor of  $k=2$ .

Measurement	Value
Conducted emissions	2.86 dB
Radiated emissions (30MHz-1GHz)	5.37 dB
Radiated emissions (1GHz -6GHz)	3.65 dB
Radiated emissions (6GHz -18GHz)	3.88 dB
Radiated emissions (18GHz -40GHz)	4.11 dB



A D T

### 3. GENERAL INFORMATION

#### 3.1 GENERAL DESCRIPTION OF EUT (WLAN)

<b>PRODUCT</b>	Dual Radio Wallplate AP
<b>MODEL NO.</b>	AP-7502
<b>POWER SUPPLY</b>	DC 12V from Adapter or DC 48V from PoE
<b>MODULATION TYPE</b>	CCK, DQPSK, DBPSK for DSSS 64QAM, 16QAM, QPSK, BPSK for OFDM 256QAM for OFDM in 11ac mode only
<b>MODULATION TECHNOLOGY</b>	DSSS,OFDM
<b>TRANSFER RATE</b>	802.11b: up to 11Mbps 802.11a / g: up to 54Mbps 802.11n: up to 300Mbps 802.11ac: up to 866.7Mbps
<b>OPERATING FREQUENCY</b>	<b>For 15.407</b> 5.18 ~ 5.24GHz, 5.745 ~ 5.825GHz
	<b>For 15.247</b> 2.412 ~ 2.462GHz
<b>NUMBER OF CHANNEL</b>	<b>For 15.407</b> 9 for 802.11a, 802.11n (HT20), 802.11ac (VHT20) 4 for 802.11n (HT40), 802.11ac (VHT40) 2 for 802.11ac (VHT80)
	<b>For 15.247</b> 11 for 802.11b, 802.11g, 802.11n (HT20) 7 for 802.11n (HT40)
<b>MAXIMUM OUTPUT POWER</b>	<b>For 15.407</b> 802.11a: 77.907mW 802.11n (HT20): 79.398mW 802.11n (HT40): 56.579mW 802.11ac (VHT20): 80.513mW 802.11ac (VHT40): 57.373mW 802.11ac (VHT80): 6.498mW <b>For 15.247</b> 802.11b: 185.368mW 802.11g: 342.766mW 802.11n (HT20): 341.779mW 802.11n (HT40): 152.641mW
<b>ANTENNA TYPE</b>	Please see NOTE
<b>DATA CABLE</b>	NA
<b>I/O PORTS</b>	Refer to user's manual
<b>ASSOCIATED DEVICES</b>	NA



**NOTE:**

1. There are Bluetooth 4.0(LE) and WLAN technology used for the EUT.
2. For WLAN, 2.4GHz and 5GHz technology can transmit at same time.
3. WLAN and Bluetooth technology can transmit at same time.
4. Radiated emissions of the simultaneous operation (WLAN & Bluetooth) has been evaluated and no non-compliance was found.
5. The Version of EUT information are as below

FW HW Version :	DVT
SW Version :	runtime FW 5.5.3.0-038R

6. The EUT could be supplied with an adapter or a PoE as the following table:

Adapter (only for test)		
Brand	Model No.	Spec.
FAIRWAY	WRG10F-120A	AC Input: 100-240V, 0.5A, 47-63Hz DC Output:12V, 0.83A
PoE (only for test)		
Brand	Model No.	Spec.
Motorola	AP-PSBIAS-2P2-AFR	AC Input: 100-240V, 0.5A, 50/60Hz DC Output: 48V, 0.35A
For radiated test, the EUT was pre-tested with adapter and PoE, the worse case was found in adapter . Therefore only the test data of the adapter was recorded in this report.		

7. There are four antennas provided to this EUT, please refer to the following table:

WLAN (2.4GHz)					
Transmitter Circuit	PCB Chain NO.	Antenna Type	Antenna Gain(dBi) Including cable loss	Connector type	Frequency range (GHz to GHz)
Chain (0)	ALA140-051025	PCB-Dipole	5.81	I-Pex	2400~2483.5
Chain (1)	ALA140-051024	PCB-Dipole	4.52	I-Pex	2400~2483.5
WLAN (5GHz)					
Transmitter Circuit	PCB Chain NO.	Antenna Type	Antenna Gain(dBi) Including cable loss	Connector type	Frequency range (GHz to GHz)
Chain (0)	ALA140-091020	PCB-Dipole	7.22	I-Pex	5150~5850
Chain (1)	ALA140-091020	PCB-Dipole	7.3	I-Pex	5150~5850
BT					
Transmitter Circuit	PCB Chain NO.	Antenna Type	Antenna Gain(dBi) Including cable loss	Connector type	Frequency range (GHz to GHz)
Chain (0)	ALC140-051020	PCB-Dipole	4.74	I-Pex	2400~2483.5

8. The EUT incorporates a MIMO function without beamforming.

MODULATION MODE	DATA RATE (MCS)	TX & RX CONFIGURATION	
<b>802.11a</b>	6 ~ 54Mbps	2TX (CDD) / 1TX	2RX
<b>802.11b</b>	1 ~ 11Mbps	2TX (CDD) / 1TX	2RX
<b>802.11g</b>	6 ~ 54Mbps	2TX (CDD) / 1TX	2RX
<b>802.11n (HT20)</b>	MCS 0~7	2TX (CDD) / 1TX	2RX
	MCS 8~15	2TX / 1TX	2RX
<b>802.11n (HT40)</b>	MCS 0~7	2TX (CDD) / 1TX	2RX
	MCS 8~15	2TX / 1TX	2RX
<b>802.11ac (VHT20) (5GHz)</b>	MCS0~8 (256QAM) N <sub>ss</sub> = 1	2TX (CDD) / 1TX	2RX
	MCS0~8 (256QAM) N <sub>ss</sub> = 2	2TX / 1TX	2RX
<b>802.11ac (VHT40) (5GHz)</b>	MCS0~9 (256QAM) N <sub>ss</sub> = 1	2TX (CDD) / 1TX	2RX
	MCS0~9 (256QAM) N <sub>ss</sub> = 2	2TX / 1TX	2RX
<b>802.11ac (VHT80) (5GHz)</b>	MCS0~9 (256QAM) N <sub>ss</sub> = 1	2TX (CDD) / 1TX	2RX
	MCS0~9 (256QAM) N <sub>ss</sub> = 2	2TX / 1TX	2RX

Note: The modulation and bandwidth are similar for 802.11n mode for 20MHz (40MHz) and 802.11ac mode for 20MHz (40MHz), therefore investigated worst case to representative mode in test report. (Final test mode refer section 3.2.1)

9. The above EUT information was declared by manufacturer and for more detailed features description, please refer to the manufacturer's specifications or user's manual.

### 3.2 DESCRIPTION OF TEST MODES

#### Operated in 5150 ~ 5250MHz band:

4 channels are provided for 802.11a, 802.11n (HT20), 802.11ac (VHT20):

CHANNEL	FREQUENCY	CHANNEL	FREQUENCY
36	5180 MHz	44	5220 MHz
40	5200 MHz	48	5240 MHz

2 channels are provided for 802.11n (HT40), 802.11ac (VHT40):

CHANNEL	FREQUENCY	CHANNEL	FREQUENCY
38	5190 MHz	46	5230 MHz

1 channel is provided for 802.11ac (VHT80):

CHANNEL	FREQUENCY
42	5210 MHz

#### Operated in 5725 ~ 5850MHz band:

5 channels are provided for 802.11a, 802.11n (HT20), 802.11ac (VHT20):

CHANNEL	FREQUENCY	CHANNEL	FREQUENCY
149	5745 MHz	161	5805 MHz
153	5765 MHz	165	5825 MHz
157	5785 MHz		

2 channels are provided for 802.11n (HT40), 802.11ac (VHT40):

CHANNEL	FREQUENCY
151	5755 MHz
159	5795 MHz

1 channel is provided for 802.11ac (VHT80):

CHANNEL	FREQUENCY
155	5775 MHz



### 3.2.1 TEST MODE APPLICABILITY AND TESTED CHANNEL DETAIL

EUT CONFIGURE MODE	APPLICABLE TO				DESCRIPTION
	PLC	RE < 1G	RE ≥ 1G	APCM	
1	√	√	√	√	With Adapter
2	√	-	-	-	With PoE

Where **PLC**: Power Line Conducted Emission      **RE < 1G**: Radiated Emission below 1GHz  
**RE ≥ 1G**: Radiated Emission above 1GHz      **APCM**: Antenna Port Conducted Measurement

**NOTE:** The EUT had been pre-tested on the positioned of each 3 axis. The worst case was found when positioned on **X-plane** (for below 1GHz) and **Y-plane** (for above 1GHz).

#### **POWER LINE CONDUCTED EMISSION TEST:**

- Pre-Scan has been conducted to determine the worst-case mode from all possible combinations between available modulations, data rates and antenna ports (if EUT with antenna diversity architecture).
- Following channel(s) was (were) selected for the final test as listed below.

MODE	AVAILABLE CHANNEL	TESTED CHANNEL	MODULATION TECHNOLOGY	MODULATION TYPE	DATA RATE (Mbps)
802.11ac (VHT20)	36 to 48 & 149 to 165	165	OFDM	BPSK	6.5

#### **RADIATED EMISSION TEST (BELOW 1 GHz):**

- Pre-Scan has been conducted to determine the worst-case mode from all possible combinations between available modulations, data rates and antenna ports (if EUT with antenna diversity architecture).
- Following channel(s) was (were) selected for the final test as listed below.

MODE	AVAILABLE CHANNEL	TESTED CHANNEL	MODULATION TECHNOLOGY	MODULATION TYPE	DATA RATE (Mbps)
802.11a	36 to 48 & 149 to 165	36, 40, 48, 149, 157, 165	OFDM	BPSK	6
For 5 GHz 802.11ac (VHT20)	36 to 48 & 149 to 165	36, 40, 48, 149, 157, 165	OFDM	BPSK	6.5
For 5 GHz 802.11ac (VHT40)	38 to 46 & 151 to 159	38, 46, 54, 151, 159	OFDM	BPSK	13.5
For 5 GHz 802.11ac (VHT80)	42 & 155	42, 155	OFDM	BPSK	29.3



**RADIATED EMISSION TEST (ABOVE 1 GHz):**

- Pre-Scan has been conducted to determine the worst-case mode from all possible combinations between available modulations, data rates and antenna ports (if EUT with antenna diversity architecture).
- Following channel(s) was (were) selected for the final test as listed below.

MODE	AVAILABLE CHANNEL	TESTED CHANNEL	MODULATION TECHNOLOGY	MODULATI ON TYPE	DATA RATE (Mbps)
802.11a	36 to 48 & 149 to 165	36, 40, 48, 149, 157, 165	OFDM	BPSK	6
802.11ac (VHT20)	36 to 48 & 149 to 165	36, 40, 48, 149, 157, 165	OFDM	BPSK	6.5
802.11ac (VHT40)	38 to 46 & 151 to 159	38, 46, 54, 151, 159	OFDM	BPSK	13.5
802.11ac (VHT80)	42 & 155	42, 155	OFDM	BPSK	29.3

**ANTENNA PORT CONDUCTED MEASUREMENT:**

- Pre-Scan has been conducted to determine the worst-case mode from all possible combinations between available modulations, data rates and antenna ports (if EUT with antenna diversity architecture).
- Following channel(s) was (were) selected for the final test as listed below.

MODE	AVAILABLE CHANNEL	TESTED CHANNEL	MODULATION TECHNOLOGY	MODULATI ON TYPE	DATA RATE (Mbps)
802.11a	36 to 48 & 149 to 165	36, 40, 48, 149, 157, 165	OFDM	BPSK	6
802.11n (HT20)	36 to 48 & 149 to 165	36, 40, 48, 149, 157, 165	OFDM	BPSK	6.5
802.11n (HT40)	38 to 46 & 151 to 159	38, 46, 54, 151, 159	OFDM	BPSK	13.5
802.11ac (VHT20)	36 to 48 & 149 to 165	36, 40, 48, 149, 157, 165	OFDM	BPSK	6.5
802.11ac (VHT40)	38 to 46 & 151 to 159	38, 46, 54, 151, 159	OFDM	BPSK	13.5
802.11ac (VHT80)	42 & 155	42, 155	OFDM	BPSK	29.3

**TEST CONDITION:**

APPLICABLE TO	ENVIRONMENTAL CONDITIONS	INPUT POWER (SYSTEM)	TESTED BY
PLC	30deg. C, 70%RH	120Vac, 60Hz	Mike Hsieh
RE<1G	27deg. C, 67%RH	120Vac, 60Hz	Robert Cheng
RE <sup>3</sup> 1G	24deg. C, 71%RH	120Vac, 60Hz	Robert Cheng
APCM	25deg. C, 60%RH	120Vac, 60Hz	Chilin Lee

### 3.3 GENERAL DESCRIPTION OF APPLIED STANDARDS

The EUT is a RF product. According to the specifications of the manufacturer, it must comply with the requirements of the following standards:

#### **FCC Part 15, Subpart E (15.407)**

**789033 D02 General UNII Test Procedures New Rules v01**

**662911 D01 Multiple Transmitter Output v02r01**

ANSI C63.10-2009

All test items have been performed and recorded as per the above standards.

**Note:** The EUT has been verified to comply with the requirements of FCC Part 15, Subpart B, Class B (DoC). The test report has been issued separately.



A D T

### 3.4 DUTY CYCLE OF TEST SIGNAL

Duty cycle of test signal is  $\geq 98\%$ , duty factor is not required.

**802.11a:** Duty cycle = 23.875 ms/23.962 ms = 0.996

**802.11ac (VHT20):** Duty cycle = 23.849 ms/23.962 ms = 0.995

**802.11ac (VHT40):** Duty cycle = 23.874 ms/23.974 ms = 0.996

**802.11ac (VHT80):** Duty cycle = 23.887 ms/23.962 ms = 0.997

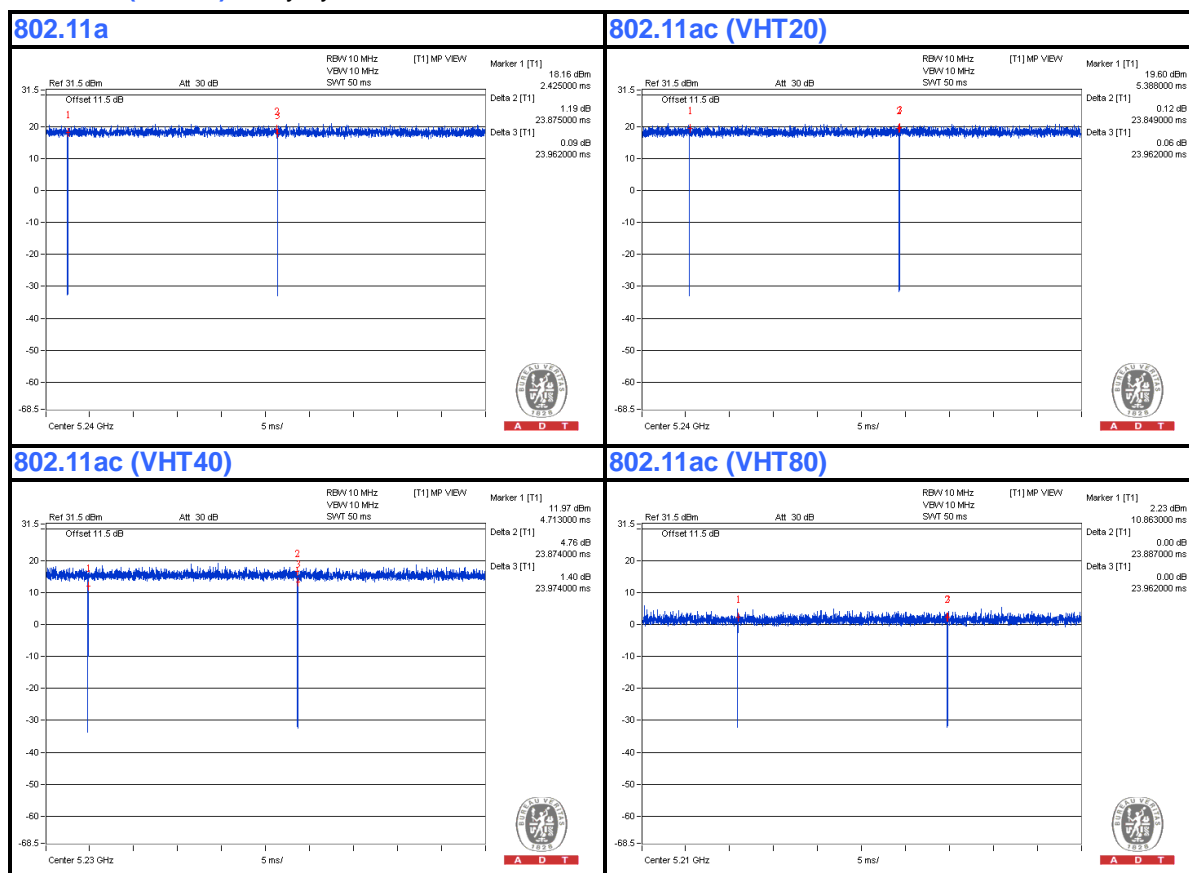



A D T

### 3.5 DESCRIPTION OF SUPPORT UNITS

The EUT has been tested as an independent unit together with other necessary accessories or support units. The following support units or accessories were used to form a representative test configuration during the tests.

No.	Product	Brand	Model No.	Serial No.	FCC ID	Remark
A	NOTEBOOK COMPUTER	DELL	E5430	HYV4VY1	FCC DoC	Provided by Lab
B	NOTEBOOK COMPUTER	DELL	PP27L	7YLB32S	FCC DoC	Provided by Lab
C	Switch	ZyXEL	ES-116P	S060H02000215	FCC DoC	Provided by Lab
D	Adapter	Fairway	WRG10F-120A	NA	FCC DoC	Supplied by client
E	PoE	Motorola	AP-PSBIAS-2P 2-AFR	NA	FCC DoC	Supplied by client

**NOTE:**

1. All power cords of the above support units are non-shielded (1.8 m).

No.	Cable	Qty.	Length (m)	Shielded (Yes/ No)	Cores (Number)	Remark
1.	RJ-45	6	10	No	0	Provided by Lab
2.	DC	1	1.8	No	0	Supplied by client
3.	RJ-45	1	3	No	0	Provided by Lab



### 3.6 CONFIGURATION OF SYSTEM UNDER TEST

For PoE Mode

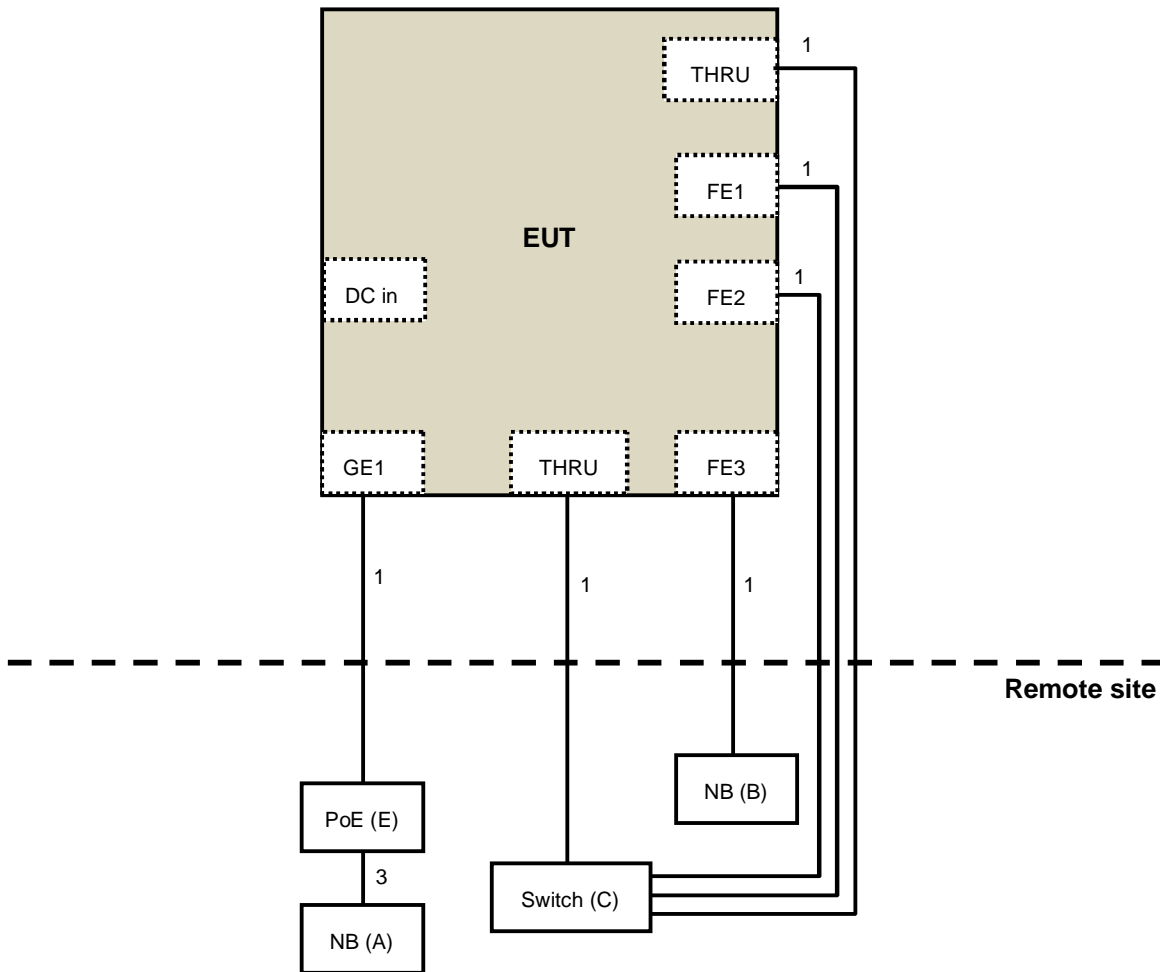

### For Adapter Mode

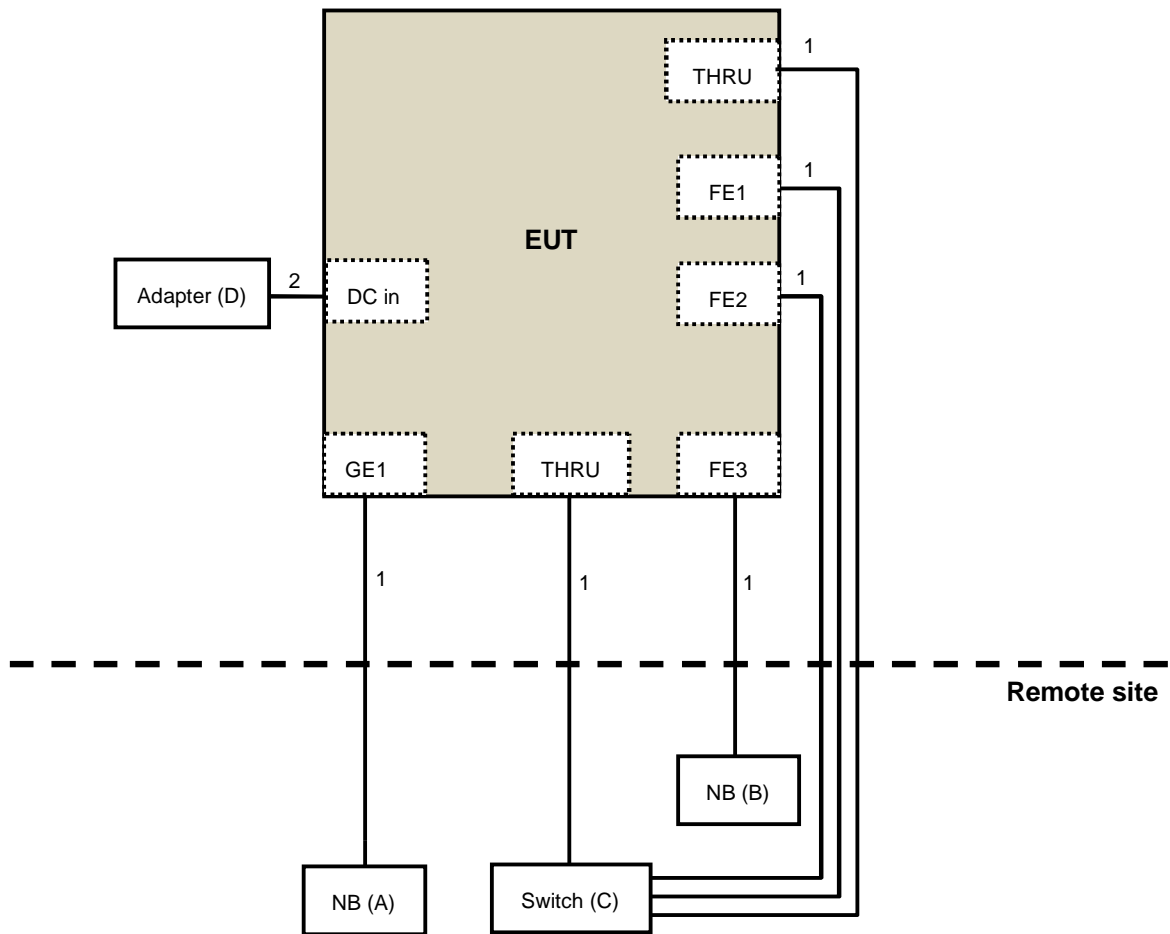



A D T

## 4. TEST TYPES AND RESULTS

### 4.1 CONDUCTED EMISSION MEASUREMENT

#### 4.1.1 LIMITS OF CONDUCTED EMISSION MEASUREMENT

FREQUENCY OF EMISSION (MHz)	CONDUCTED LIMIT (dB $\mu$ V)	
	Quasi-peak	Average
0.15-0.5	66 to 56	56 to 46
0.5-5	56	46
5-30	60	50

- NOTE:**
1. The lower limit shall apply at the transition frequencies.
  2. The limit decreases in line with the logarithm of the frequency in the range of 0.15 to 0.50 MHz.

#### 4.1.2 TEST INSTRUMENTS

DESCRIPTION & MANUFACTURER	MODEL NO.	SERIAL NO.	CALIBRATED DATE	CALIBRATED UNTIL
Test Receiver ROHDE & SCHWARZ	ESCS 30	100375	Apr. 29, 2014	Apr. 28, 2015
Line-Impedance Stabilization Network (for EUT) SCHWARZBECK	NSLK8127	8127-522	Sep. 12, 2013	Sep. 11, 2014
Line-Impedance Stabilization Network (for Peripheral)	ENV216	100071	Nov. 13, 2013	Nov. 12, 2014
RF Cable (JYEBAO)	5DFB	COCCAB-001	Mar. 10, 2014	Mar. 09, 2015
50 ohms Terminator	N/A	EMC-03	Sep. 24, 2013	Sep. 23, 2014
50 ohms Terminator	N/A	EMC-02	Oct. 01, 2013	Sep. 30, 2014
Software ADT	BV ADT_Cond_V7.3.7. 3	NA	NA	NA

**Note:**

1. The calibration interval of the above test instruments is 12 months and the calibrations are traceable to NML/ROC and NIST/USA.
2. The test was performed in Shielded Room No. C.
3. The VCCI Con C Registration No. is C-3611.
4. Tested Date: July 24, 2014

### 4.1.3 TEST PROCEDURES

- a. The EUT was placed 0.4 meters from the conducting wall of the shielded room with EUT being connected to the power mains through a line impedance stabilization network (LISN). Other support units were connected to the power mains through another LISN.
- b. The two LISNs provide 50 ohm/ 50uH of coupling impedance for the measuring instrument.
- c. Both lines of the power mains connected to the EUT were checked for maximum conducted interference.
- d. The frequency range from 150kHz to 30MHz was searched. Emission level under (Limit – 20dB) was not recorded.

**NOTE:**

1. The resolution bandwidth of test receiver is 9kHz for Quasi-peak detection (QP) & Average detection (AV).

### 4.1.4 DEVIATION FROM TEST STANDARD

No deviation

### 4.1.5 TEST SETUP

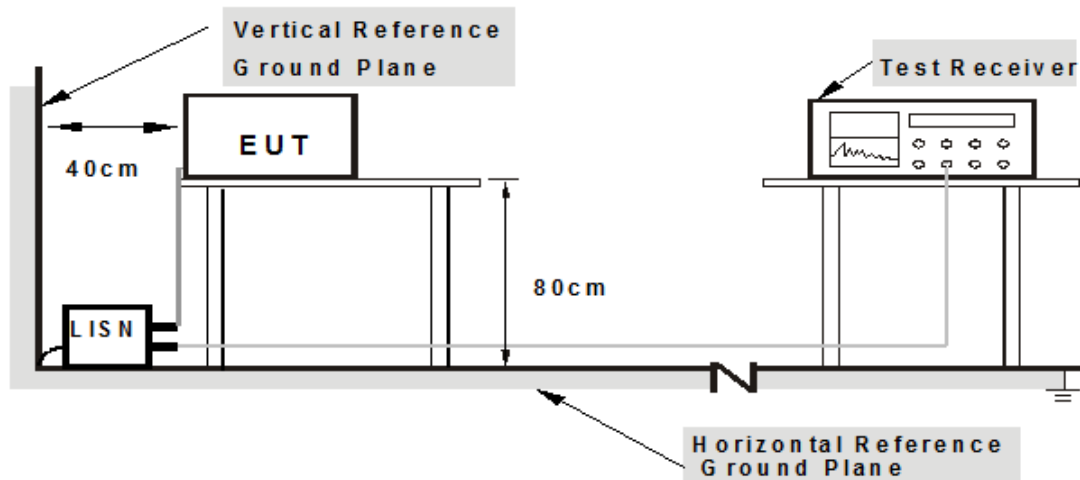

**Note: 1. Support units were connected to second LISN.**

For the actual test configuration, please refer to the related item – Photographs of the Test Configuration.



A D T

#### 4.1.6 EUT OPERATING CONDITIONS

1. Connect the EUT with the support units A-B (NB) which is placed on table in remote site.
2. The communication partner run test program “WiFi CART[Ver.4.9] paste Cart command.txt]+ BT HyperTerminal paste command” to enable EUT under transmission/receiving condition continuously at specific channel frequency.

#### 4.1.7 TEST RESULTS (MODE 1)

<b>PHASE</b>	Line (L)	<b>DETECTOR FUNCTION</b>	Quasi-Peak (QP) / Average (AV)
--------------	----------	--------------------------	--------------------------------

No	Freq. [MHz]	Corr. Factor (dB)	Reading Value [dB (uV)]		Emission Level [dB (uV)]		Limit [dB (uV)]		Margin (dB)	
			Q.P.	AV.	Q.P.	AV.	Q.P.	AV.	Q.P.	AV.
			1	0.20078	0.07	47.21	40.04	47.28	40.11	63.58
<b>2</b>	<b>0.41172</b>	<b>0.09</b>	<b>46.76</b>	<b>38.12</b>	<b>46.85</b>	<b>38.21</b>	<b>57.61</b>	<b>47.61</b>	<b>-10.76</b>	<b>-9.40</b>
3	0.92734	0.13	39.53	27.47	39.66	27.60	56.00	46.00	-16.34	-18.40
4	2.48047	0.19	36.99	24.98	37.18	25.17	56.00	46.00	-18.82	-20.83
5	15.98438	0.61	32.13	24.81	32.74	25.42	60.00	50.00	-27.26	-24.58
6	22.59375	0.78	33.09	23.85	33.87	24.63	60.00	50.00	-26.13	-25.37

#### REMARKS:

1. Q.P. and AV. are abbreviations of quasi-peak and average individually.
2. The emission levels of other frequencies were very low against the limit.
3. Margin value = Emission Level – Limit value
4. Correction Factor = Insertion loss + Cable loss
5. Emission Level = Correction Factor + Reading Value

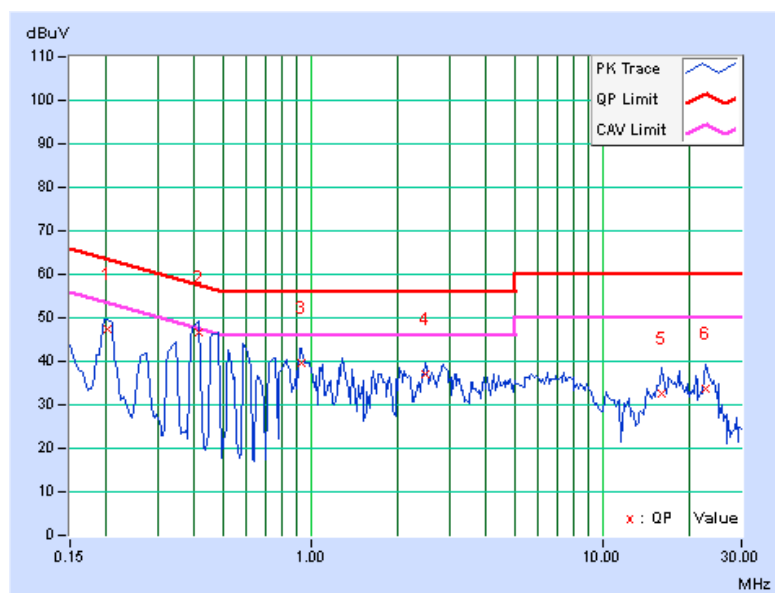

<b>PHASE</b>	Neutral (N)	<b>DETECTOR FUNCTION</b>	Quasi-Peak (QP) / Average (AV)
--------------	-------------	--------------------------	--------------------------------

No	Freq. [MHz]	Corr. Factor (dB)	Reading Value [dB (uV)]		Emission Level [dB (uV)]		Limit [dB (uV)]		Margin (dB)	
			Q.P.	AV.	Q.P.	AV.	Q.P.	AV.	Q.P.	AV.
1	0.20078	0.07	47.27	38.91	47.34	38.98	63.58	53.58	-16.24	-14.60
2	0.41172	0.09	46.80	37.97	46.89	38.06	57.61	47.61	-10.72	-9.55
3	0.59141	0.10	41.27	31.70	41.37	31.80	56.00	46.00	-14.63	-14.20
4	1.28516	0.14	38.90	25.39	39.04	25.53	56.00	46.00	-16.96	-20.47
5	16.73828	0.62	30.68	20.44	31.30	21.06	60.00	50.00	-28.70	-28.94
6	23.13281	0.79	34.16	28.18	34.95	28.97	60.00	50.00	-25.05	-21.03

**REMARKS:**

1. Q.P. and AV. are abbreviations of quasi-peak and average individually.
2. The emission levels of other frequencies were very low against the limit.
3. Margin value = Emission Level – Limit value
4. Correction Factor = Insertion loss + Cable loss
5. Emission Level = Correction Factor + Reading Value

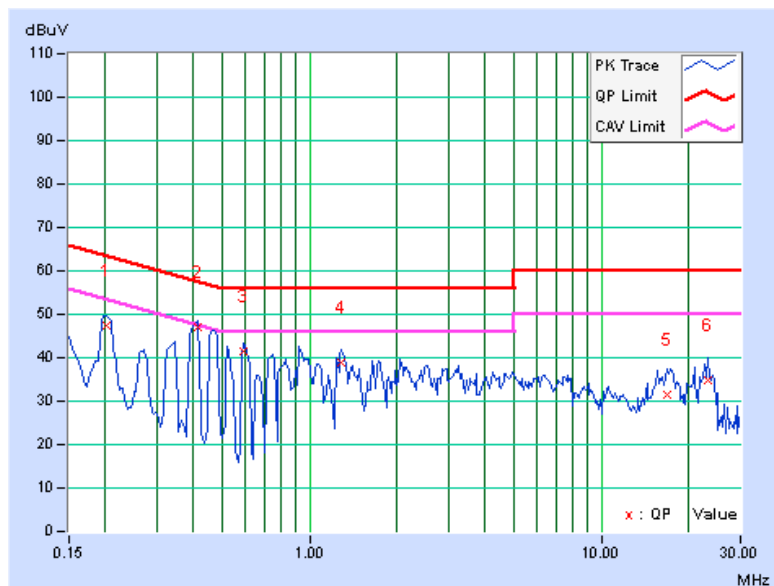

4.1.8 TEST RESULTS (MODE 2)

<b>PHASE</b>	Line (L)	<b>DETECTOR FUNCTION</b>	Quasi-Peak (QP) / Average (AV)
--------------	----------	--------------------------	--------------------------------

No	Freq. [MHz]	Corr. Factor [dB]	Reading Value [dB (uV)]		Emission Level [dB (uV)]		Limit [dB (uV)]		Margin (dB)	
			Q.P.	AV.	Q.P.	AV.	Q.P.	AV.	Q.P.	AV.
1	0.17344	0.07	42.30	33.91	42.37	33.98	64.79	54.79	-22.43	-20.82
2	0.20469	0.07	39.15	31.20	39.22	31.27	63.42	53.42	-24.20	-22.15
3	0.51328	0.10	32.24	31.12	32.34	31.22	56.00	46.00	-23.66	-14.78
4	3.79297	0.25	26.15	18.17	26.40	18.42	56.00	46.00	-29.60	-27.58
5	7.99609	0.39	31.60	29.75	31.99	30.14	60.00	50.00	-28.01	-19.86
6	23.60938	0.81	40.58	34.55	41.39	35.36	60.00	50.00	-18.61	-14.64

REMARKS:

1. Q.P. and AV. are abbreviations of quasi-peak and average individually.
2. The emission levels of other frequencies were very low against the limit.
3. Margin value = Emission Level – Limit value
4. Correction Factor = Insertion loss + Cable loss
5. Emission Level = Correction Factor + Reading Value

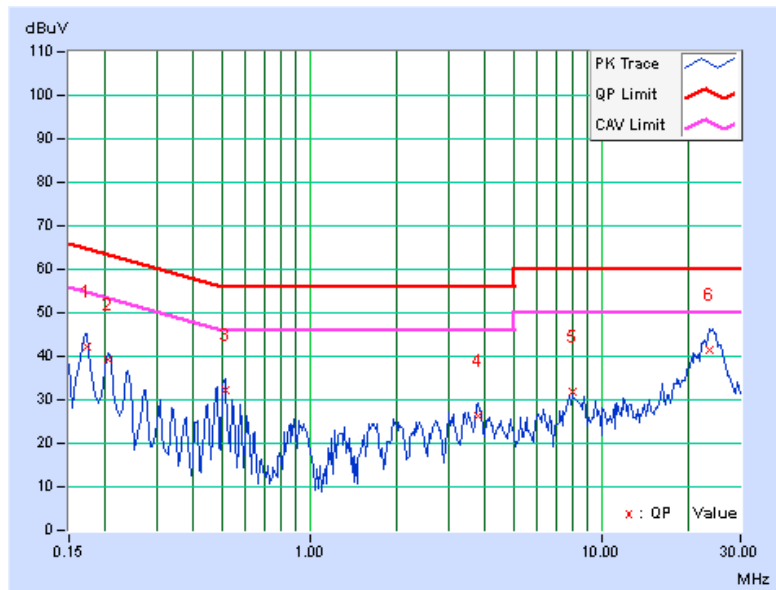



<b>PHASE</b>	Neutral (N)	<b>DETECTOR FUNCTION</b>	Quasi-Peak (QP) / Average (AV)
--------------	-------------	--------------------------	--------------------------------

No	Freq. [MHz]	Corr. Factor [dB]	Reading Value [dB (uV)]		Emission Level [dB (uV)]		Limit [dB (uV)]		Margin (dB)	
			Q.P.	AV.	Q.P.	AV.	Q.P.	AV.	Q.P.	AV.
1	0.17344	0.07	43.40	35.66	43.47	35.73	64.79	54.79	-21.32	-19.06
2	0.20469	0.07	39.53	32.48	39.60	32.55	63.42	53.42	-23.82	-20.87
3	0.51328	0.10	32.52	31.65	32.62	31.75	56.00	46.00	-23.38	-14.25
4	3.78516	0.25	28.76	21.19	29.01	21.44	56.00	46.00	-26.99	-24.56
5	7.99219	0.39	31.32	27.49	31.71	27.88	60.00	50.00	-28.29	-22.12
6	23.86328	0.81	42.22	36.47	43.03	37.28	60.00	50.00	-16.97	-12.72

**REMARKS:**

1. Q.P. and AV. are abbreviations of quasi-peak and average individually.
2. The emission levels of other frequencies were very low against the limit.
3. Margin value = Emission Level – Limit value
4. Correction Factor = Insertion loss + Cable loss
5. Emission Level = Correction Factor + Reading Value

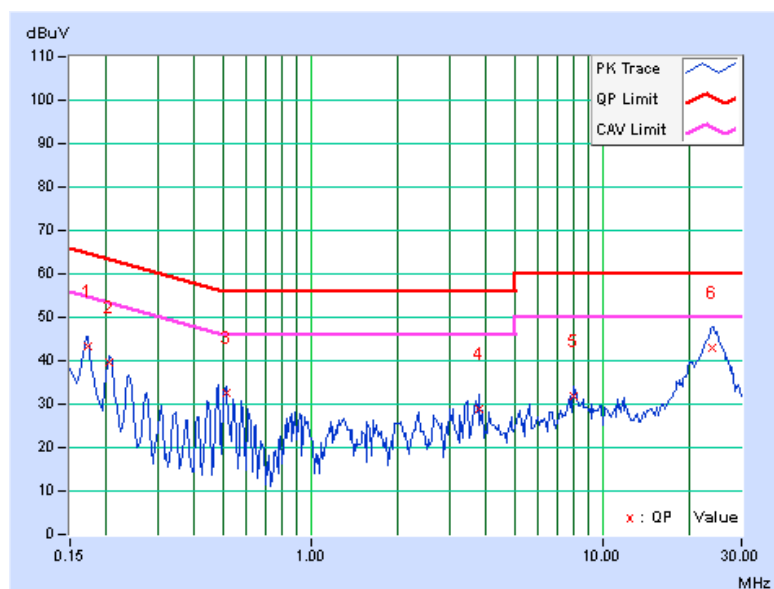

## 4.2 RADIATED EMISSION AND BANDEDGE MEASUREMENT

### 4.2.1 LIMITS OF RADIATED EMISSION AND BANDEDGE MEASUREMENT

Radiated emissions which fall in the restricted bands must comply with the radiated emission limits specified as below table:

Frequencies (MHz)	Field strength (microvolts/meter)	Measurement distance (meters)
0.009-0.490	2400/F(kHz)	300
0.490-1.705	24000/F(kHz)	30
1.705-30.0	30	30
30-88	100	3
88-216	150	3
216-960	200	3
Above 960	500	3

**NOTE:**

1. The lower limit shall apply at the transition frequencies.
2. Emission level (dBuV/m) = 20 log Emission level (uV/m).
3. For frequencies above 1000MHz, the field strength limits are based on average detector, however, the peak field strength of any emission shall not exceed the maximum permitted average limits, specified above by more than 20dB under any condition of modulation.

#### 4.2.2 LIMITS OF UNWANTED EMISSION OUT OF THE RESTRICTED BANDS

APPLICABLE TO	LIMIT	
789033 D02 General UNII Test Procedures New Rules v01	FIELD STRENGTH AT 3m	
	PK:74 (dBμV/m)	AV:54 (dBμV/m)
APPLICABLE TO	EIRP LIMIT	EQUIVALENT FIELD STRENGTH AT 3m
15.407(b)(1)	PK:-27 (dBm/MHz)	PK:68.2(dBμV/m)
15.407(b)(2)		
15.407(b)(3)		
15.407(b)(4)	PK:-27 (dBm/MHz) <sup>*1</sup> PK:-17 (dBm/MHz) <sup>*2</sup>	PK: 68.2(dBμV/m) <sup>*1</sup> PK:78.2 (dBμV/m) <sup>*2</sup>

**NOTE:** <sup>\*1</sup> beyond 10MHz of the band edge    <sup>\*2</sup> within 10 MHz of band edge

The following formula is used to convert the equipment isotropic radiated power (eirp) to field strength:

$$E = \frac{1000000\sqrt{30P}}{3} \quad \mu\text{V/m, where P is the eirp (Watts).}$$



A D T

#### 4.2.3 TEST INSTRUMENTS

DESCRIPTION & MANUFACTURER	MODEL NO.	SERIAL NO.	CALIBRATED DATE	CALIBRATED UNTIL
MXE EMI Receiver Agilent	N9038A	MY51210105	July 21, 2014	July 20, 2015
Pre-Amplifier Mini-Circuits	ZFL-1000VH2 B	AMP-ZFL-03	Nov. 13, 2013	Nov. 12, 2014
Trilog Broadband Antenna SCHWARZBECK	VULB 9168	9168-360	Feb. 26, 2014	Feb. 25, 2015
RF Cable	NA	CHGCAB_001	Oct. 05, 2013	Oct. 04, 2014
Spectrum Analyzer R&S	FSV40	100964	July 05, 2014	July 04, 2015
Horn_Antenna AISI	AIH.8018	0000320091110	Nov. 18, 2013	Nov. 17, 2014
Pre-Amplifier Agilent	8449B	3008A02578	June 24, 2014	June 23, 2015
RF Cable	NA	RF104-201 RF104-203 RF104-204	Dec. 12, 2013	Dec. 11, 2014
Spectrum Analyzer Agilent	E4446A	MY48250253	Aug. 28, 2013	Aug. 27, 2014
Pre-Amplifier SPACEK LABS	SLKKa-48-6	9K16	Nov. 13, 2013	Nov. 12, 2014
Horn_Antenna SCHWARZBECK	BBHA 9170	9170-424	Oct. 08, 2013	Oct. 07, 2014
Software	ADT_Radiated _V8.7.07	NA	NA	NA
Antenna Tower & Turn Table CT	NA	NA	NA	NA

**Note:**

1. The calibration interval of the above test instruments is 12 months and the calibrations are traceable to NML/ROC and NIST/USA.
2. The horn antenna, preamplifier (model: 8449B) are used only for the measurement of emission frequency above 1GHz if tested.
- 3 The test was performed in 966 Chamber No. G.
4. The FCC Site Registration No. is 966073.
- 5 The VCCI Site Registration No. is G-137.
- 6 The CANADA Site Registration No. is IC 7450H-2.
- 7 Tested Date: July 30 to Aug. 04, 2014

#### 4.2.4 TEST PROCEDURES

- a. The EUT was placed on the top of a rotating table 0.8 meters above the ground at 3 meter chamber room for test. The table was rotated 360 degrees to determine the position of the highest radiation.
- b. The EUT was set 3 meters away from the interference-receiving antenna, which was mounted on the top of a variable-height antenna tower.
- c. The height of antenna is varied from one meter to four meters above the ground to determine the maximum value of the field strength. Both horizontal and vertical polarizations of the antenna are set to make the measurement.
- d. For each suspected emission, the EUT was arranged to its worst case and then the antenna was tuned to heights from 1 meter to 4 meters and the rotatable table was turned from 0 degrees to 360 degrees to find the maximum reading.
- e. The test-receiver system was set to quasi-peak detect function and specified bandwidth with maximum hold mode when the test frequency is below 1 GHz.
- f. The test-receiver system was set to peak and average detect function and specified bandwidth with maximum hold mode when the test frequency is above 1 GHz. If the peak reading value also meets average limit, measurement with the average detector is unnecessary.

**Note:**

1. The resolution bandwidth and video bandwidth of test receiver/spectrum analyzer is 120kHz for Quasi-peak detection (QP) at frequency below 1GHz.
2. The resolution bandwidth of test receiver/spectrum analyzer is 1 MHz and the video bandwidth is 3 MHz for Peak detection (PK) at frequency above 1GHz.
3. The resolution bandwidth of test receiver/spectrum analyzer is 1MHz and the video bandwidth is 3MHz for RMS Average (Duty cycle < 98%) for Average detection (AV) at frequency above 1GHz, then the measurement results was added to a correction factor ( $10 \log(1/\text{duty cycle})$ ).
4. The resolution bandwidth of test receiver/spectrum analyzer is 1MHz and the video bandwidth is 10Hz (Duty cycle  $\geq 98\%$ ) for Average detection (AV) at frequency above 1GHz.
5. All modes of operation were investigated and the worst-case emissions are reported.

#### 4.2.5 DEVIATION FROM TEST STANDARD

No deviation

#### 4.2.6 TEST SETUP

##### <Frequency Range below 1GHz>

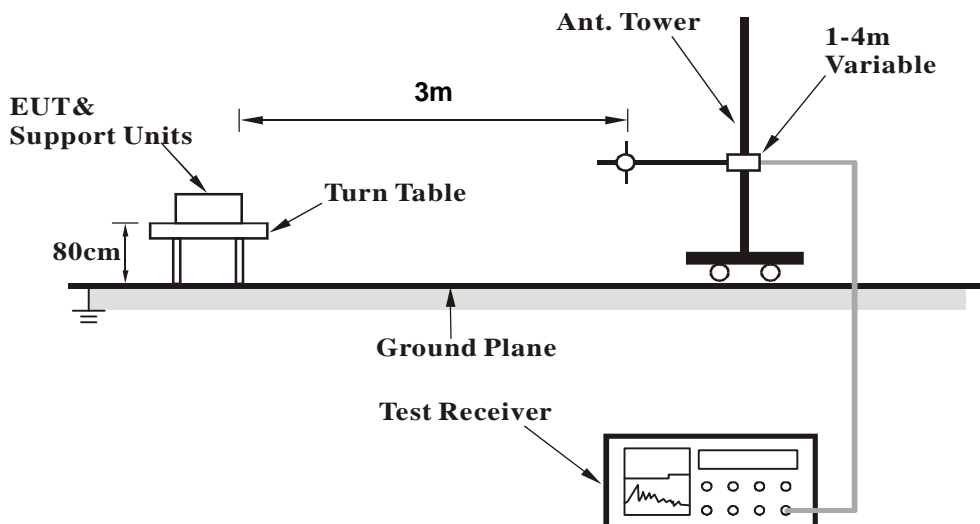

##### <Frequency Range above 1GHz>

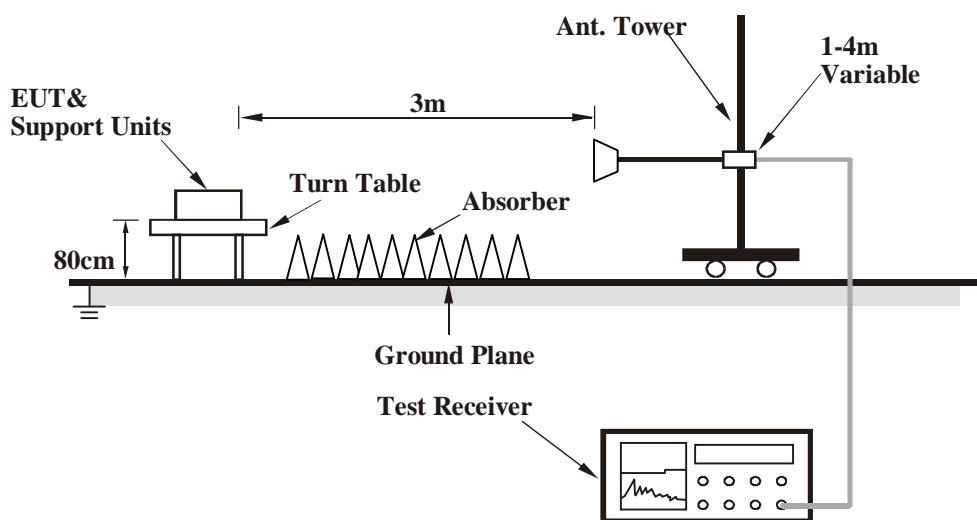

For the actual test configuration, please refer to the related item – Photographs of the Test Configuration.

#### 4.2.7 EUT OPERATING CONDITION

Same as 4.1.6



A D T

## 4.2.8 TEST RESULTS

### BELOW 1GHz WORST-CASE DATA

#### 802.11a

<b>CHANNEL</b>	TX Channel 36	<b>DETECTOR FUNCTION</b>	Quasi-Peak (QP)
<b>FREQUENCY RANGE</b>	Below 1GHz		

ANTENNA POLARITY & TEST DISTANCE: HORIZONTAL AT 3 M								
NO.	FREQ. (MHz)	EMISSION LEVEL (dBuV/m)	LIMIT (dBuV/m)	MARGIN (dB)	ANTENNA HEIGHT (m)	TABLE ANGLE (Degree)	RAW VALUE (dBuV)	CORRECTION FACTOR (dB/m)
1	76.97	32.3 QP	40.0	-7.8	2.00 H	271	49.69	-17.44
2	111.09	33.8 QP	43.5	-9.7	1.50 H	92	49.98	-16.20
3	153.60	36.7 QP	43.5	-6.8	2.00 H	88	49.78	-13.05
4	375.29	37.6 QP	46.0	-8.4	1.00 H	63	47.80	-10.22
5	502.73	37.6 QP	46.0	-8.4	1.50 H	104	44.94	-7.30
6	1000.00	45.6 QP	54.0	-8.4	1.00 H	64	44.13	1.46
ANTENNA POLARITY & TEST DISTANCE: VERTICAL AT 3 M								
NO.	FREQ. (MHz)	EMISSION LEVEL (dBuV/m)	LIMIT (dBuV/m)	MARGIN (dB)	ANTENNA HEIGHT (m)	TABLE ANGLE (Degree)	RAW VALUE (dBuV)	CORRECTION FACTOR (dB/m)
1	50.83	31.8 QP	40.0	-8.2	1.00 V	216	45.33	-13.57
2	76.58	34.3 QP	40.0	-5.8	1.00 V	352	51.51	-17.26
3	117.68	35.1 QP	43.5	-8.4	1.50 V	205	50.45	-15.37
4	153.44	34.3 QP	43.5	-9.3	1.00 V	334	47.31	-13.06
5	426.40	37.3 QP	46.0	-8.7	1.50 V	360	46.14	-8.81
6	1000.00	41.0 QP	54.0	-13.0	1.00 V	57	39.57	1.46

#### REMARKS:

1. Emission Level(dBuV/m) = Raw Value(dBuV) + Correction Factor(dB/m)
2. Correction Factor(dB/m) = Antenna Factor(dB/m) + Cable Factor(dB) – Pre-Amplifier Factor(dB)
3. The other emission levels were very low against the limit.
4. Margin value = Emission Level – Limit value



A D T

<b>CHANNEL</b>	TX Channel 40	<b>DETECTOR FUNCTION</b>	Quasi-Peak (QP)
<b>FREQUENCY RANGE</b>	Below 1GHz		

**ANTENNA POLARITY & TEST DISTANCE: HORIZONTAL AT 3 M**

NO.	FREQ. (MHz)	EMISSION LEVEL (dBuV/m)	LIMIT (dBuV/m)	MARGIN (dB)	ANTENNA HEIGHT (m)	TABLE ANGLE (Degree)	RAW VALUE (dBuV)	CORRECTION FACTOR (dB/m)
1	76.78	31.9 QP	40.0	-8.1	2.00 H	271	49.22	-17.35
2	111.04	33.3 QP	43.5	-10.2	1.50 H	92	49.52	-16.21
3	153.41	36.9 QP	43.5	-6.6	2.00 H	85	49.94	-13.06
4	375.10	37.7 QP	46.0	-8.3	1.00 H	70	47.93	-10.23
5	502.89	37.5 QP	46.0	-8.5	1.50 H	112	44.84	-7.30
6	1000.00	45.3 QP	54.0	-8.7	1.00 H	70	43.86	1.46

**ANTENNA POLARITY & TEST DISTANCE: VERTICAL AT 3 M**

NO.	FREQ. (MHz)	EMISSION LEVEL (dBuV/m)	LIMIT (dBuV/m)	MARGIN (dB)	ANTENNA HEIGHT (m)	TABLE ANGLE (Degree)	RAW VALUE (dBuV)	CORRECTION FACTOR (dB/m)
1	50.99	32.2 QP	40.0	-7.8	1.00 V	222	45.76	-13.56
2	76.38	33.8 QP	40.0	-6.2	1.00 V	350	50.93	-17.17
3	117.83	34.8 QP	43.5	-8.7	1.50 V	205	50.13	-15.34
4	153.22	34.3 QP	43.5	-9.2	1.00 V	334	47.35	-13.07
5	426.63	37.2 QP	46.0	-8.8	1.50 V	360	45.97	-8.80
6	1000.00	40.9 QP	54.0	-13.1	1.00 V	51	39.43	1.46

**REMARKS:**

1. Emission Level(dBuV/m) = Raw Value(dBuV) + Correction Factor(dB/m)
2. Correction Factor(dB/m) = Antenna Factor(dB/m) + Cable Factor(dB) – Pre-Amplifier Factor(dB)
3. The other emission levels were very low against the limit.
4. Margin value = Emission Level – Limit value





A D T

<b>CHANNEL</b>	TX Channel 48	<b>DETECTOR FUNCTION</b>	Quasi-Peak (QP)
<b>FREQUENCY RANGE</b>	Below 1GHz		

**ANTENNA POLARITY & TEST DISTANCE: HORIZONTAL AT 3 M**

NO.	FREQ. (MHz)	EMISSION LEVEL (dBuV/m)	LIMIT (dBuV/m)	MARGIN (dB)	ANTENNA HEIGHT (m)	TABLE ANGLE (Degree)	RAW VALUE (dBuV)	CORRECTION FACTOR (dB/m)
1	76.73	31.8 QP	40.0	-8.2	2.00 H	264	49.13	-17.33
2	111.09	33.5 QP	43.5	-10.1	1.50 H	95	49.65	-16.20
3	153.54	36.7 QP	43.5	-6.8	2.00 H	87	49.71	-13.05
4	375.26	37.9 QP	46.0	-8.1	1.00 H	75	48.11	-10.22
5	502.69	37.3 QP	46.0	-8.7	1.50 H	106	44.59	-7.30
6	1000.00	45.2 QP	54.0	-8.9	1.00 H	66	43.69	1.46

**ANTENNA POLARITY & TEST DISTANCE: VERTICAL AT 3 M**

NO.	FREQ. (MHz)	EMISSION LEVEL (dBuV/m)	LIMIT (dBuV/m)	MARGIN (dB)	ANTENNA HEIGHT (m)	TABLE ANGLE (Degree)	RAW VALUE (dBuV)	CORRECTION FACTOR (dB/m)
1	51.16	31.8 QP	40.0	-8.2	1.00 V	225	45.41	-13.57
2	76.15	33.3 QP	40.0	-6.7	1.00 V	350	50.34	-17.07
3	117.97	34.7 QP	43.5	-8.8	1.50 V	196	49.97	-15.31
4	153.29	34.2 QP	43.5	-9.3	1.00 V	336	47.26	-13.07
5	426.54	37.3 QP	46.0	-8.7	1.50 V	360	46.08	-8.80
6	1000.00	40.7 QP	54.0	-13.3	1.00 V	53	39.28	1.46

**REMARKS:**

1. Emission Level(dBuV/m) = Raw Value(dBuV) + Correction Factor(dB/m)
2. Correction Factor(dB/m) = Antenna Factor(dB/m) + Cable Factor(dB) – Pre-Amplifier Factor(dB)
3. The other emission levels were very low against the limit.
4. Margin value = Emission Level – Limit value



A D T

<b>CHANNEL</b>	TX Channel 149	<b>DETECTOR FUNCTION</b>	Quasi-Peak (QP)
<b>FREQUENCY RANGE</b>	Below 1GHz		

**ANTENNA POLARITY & TEST DISTANCE: HORIZONTAL AT 3 M**

NO.	FREQ. (MHz)	EMISSION LEVEL (dBuV/m)	LIMIT (dBuV/m)	MARGIN (dB)	ANTENNA HEIGHT (m)	TABLE ANGLE (Degree)	RAW VALUE (dBuV)	CORRECTION FACTOR (dB/m)
1	51.29	32.5 QP	40.0	-7.5	1.00 H	222	46.06	-13.57
2	76.05	33.0 QP	40.0	-7.0	1.00 H	331	50.03	-17.02
3	77.08	32.2 QP	40.0	-7.8	2.00 H	274	49.64	-17.48
4	111.11	34.4 QP	43.5	-9.2	1.50 H	89	50.55	-16.20
5	118.59	34.1 QP	43.5	-9.4	1.50 H	226	49.35	-15.29
6	153.33	36.8 QP	43.5	-6.7	2.00 H	94	49.83	-13.06
7	153.40	34.2 QP	43.5	-9.3	1.00 H	353	47.25	-13.06
8	375.24	37.7 QP	46.0	-8.3	1.00 H	62	47.93	-10.23
9	427.13	37.1 QP	46.0	-8.9	1.50 H	360	45.93	-8.79
10	502.51	38.4 QP	46.0	-7.6	1.50 H	93	45.72	-7.30
11	1000.00	39.8 QP	54.0	-14.2	1.00 H	47	38.37	1.46
12	1000.00	44.9 QP	54.0	-9.1	1.00 H	59	43.41	1.46

**ANTENNA POLARITY & TEST DISTANCE: VERTICAL AT 3 M**

NO.	FREQ. (MHz)	EMISSION LEVEL (dBuV/m)	LIMIT (dBuV/m)	MARGIN (dB)	ANTENNA HEIGHT (m)	TABLE ANGLE (Degree)	RAW VALUE (dBuV)	CORRECTION FACTOR (dB/m)
1	51.10	31.8 QP	40.0	-8.2	1.00 V	219	45.38	-13.57
2	76.42	35.1 QP	40.0	-4.9	1.00 V	355	52.25	-17.19
3	117.53	35.7 QP	43.5	-7.8	1.50 V	206	51.08	-15.39
4	153.26	33.9 QP	43.5	-9.6	1.00 V	329	47.01	-13.07
5	426.01	36.7 QP	46.0	-9.3	1.50 V	360	45.48	-8.82
6	1000.00	41.2 QP	54.0	-12.8	1.00 V	62	39.72	1.46

**REMARKS:**

1. Emission Level(dBuV/m) = Raw Value(dBuV) + Correction Factor(dB/m)
2. Correction Factor(dB/m) = Antenna Factor(dB/m) + Cable Factor(dB) – Pre-Amplifier Factor(dB)
3. The other emission levels were very low against the limit.
4. Margin value = Emission Level – Limit value



A D T

<b>CHANNEL</b>	TX Channel 157	<b>DETECTOR FUNCTION</b>	Quasi-Peak (QP)
<b>FREQUENCY RANGE</b>	Below 1GHz		

**ANTENNA POLARITY & TEST DISTANCE: HORIZONTAL AT 3 M**

NO.	FREQ. (MHz)	EMISSION LEVEL (dBuV/m)	LIMIT (dBuV/m)	MARGIN (dB)	ANTENNA HEIGHT (m)	TABLE ANGLE (Degree)	RAW VALUE (dBuV)	CORRECTION FACTOR (dB/m)
1	77.21	32.6 QP	40.0	-7.4	2.00 H	271	50.14	-17.53
2	110.94	34.6 QP	43.5	-8.9	1.50 H	82	50.84	-16.22
3	153.08	36.4 QP	43.5	-7.1	2.00 H	92	49.46	-13.08
4	375.01	37.2 QP	46.0	-8.8	1.00 H	61	47.47	-10.23
5	502.46	38.6 QP	46.0	-7.4	1.50 H	91	45.93	-7.30
6	1000.00	44.8 QP	54.0	-9.2	1.00 H	60	43.34	1.46

**ANTENNA POLARITY & TEST DISTANCE: VERTICAL AT 3 M**

NO.	FREQ. (MHz)	EMISSION LEVEL (dBuV/m)	LIMIT (dBuV/m)	MARGIN (dB)	ANTENNA HEIGHT (m)	TABLE ANGLE (Degree)	RAW VALUE (dBuV)	CORRECTION FACTOR (dB/m)
1	50.97	32.1 QP	40.0	-7.9	1.00 V	226	45.65	-13.56
2	76.21	35.5 QP	40.0	-4.5	1.00 V	357	52.63	-17.09
3	117.56	36.1 QP	43.5	-7.4	1.50 V	203	51.49	-15.39
4	153.20	33.9 QP	43.5	-9.6	1.00 V	330	46.98	-13.07
5	426.19	37.1 QP	46.0	-8.9	1.50 V	360	45.92	-8.81
6	1000.00	41.7 QP	54.0	-12.3	1.00 V	67	40.22	1.46

**REMARKS:**

1. Emission Level(dBuV/m) = Raw Value(dBuV) + Correction Factor(dB/m)
2. Correction Factor(dB/m) = Antenna Factor(dB/m) + Cable Factor(dB) – Pre-Amplifier Factor(dB)
3. The other emission levels were very low against the limit.
4. Margin value = Emission Level – Limit value



A D T

<b>CHANNEL</b>	TX Channel 165	<b>DETECTOR FUNCTION</b>	Quasi-Peak (QP)
<b>FREQUENCY RANGE</b>	Below 1GHz		

**ANTENNA POLARITY & TEST DISTANCE: HORIZONTAL AT 3 M**

NO.	FREQ. (MHz)	EMISSION LEVEL (dBuV/m)	LIMIT (dBuV/m)	MARGIN (dB)	ANTENNA HEIGHT (m)	TABLE ANGLE (Degree)	RAW VALUE (dBuV)	CORRECTION FACTOR (dB/m)
1	77.30	32.5 QP	40.0	-7.5	2.00 H	272	50.04	-17.58
2	110.97	34.6 QP	43.5	-8.9	1.50 H	83	50.78	-16.22
3	152.90	36.0 QP	43.5	-7.5	2.00 H	97	49.10	-13.08
4	374.86	36.9 QP	46.0	-9.2	1.00 H	66	47.09	-10.24
5	502.46	38.2 QP	46.0	-7.9	1.50 H	89	45.45	-7.30
6	1000.00	45.1 QP	54.0	-8.9	1.00 H	54	43.66	1.46

**ANTENNA POLARITY & TEST DISTANCE: VERTICAL AT 3 M**

NO.	FREQ. (MHz)	EMISSION LEVEL (dBuV/m)	LIMIT (dBuV/m)	MARGIN (dB)	ANTENNA HEIGHT (m)	TABLE ANGLE (Degree)	RAW VALUE (dBuV)	CORRECTION FACTOR (dB/m)
1	51.03	32.1 QP	40.0	-7.9	1.00 V	229	45.66	-13.57
2	76.26	35.4 QP	40.0	-4.7	1.00 V	351	52.47	-17.12
3	117.54	35.8 QP	43.5	-7.7	1.50 V	205	51.17	-15.39
4	153.13	33.9 QP	43.5	-9.6	1.00 V	323	47.00	-13.07
5	426.24	37.6 QP	46.0	-8.4	1.50 V	360	46.42	-8.81
6	1000.00	41.7 QP	54.0	-12.3	1.00 V	62	40.27	1.46

**REMARKS:**

1. Emission Level(dBuV/m) = Raw Value(dBuV) + Correction Factor(dB/m)
2. Correction Factor(dB/m) = Antenna Factor(dB/m) + Cable Factor(dB) – Pre-Amplifier Factor(dB)
3. The other emission levels were very low against the limit.
4. Margin value = Emission Level – Limit value

**802.11ac (VHT20)**

<b>CHANNEL</b>	TX Channel 36	<b>DETECTOR FUNCTION</b>	Quasi-Peak (QP)
<b>FREQUENCY RANGE</b>	Below 1GHz		

<b>ANTENNA POLARITY &amp; TEST DISTANCE: HORIZONTAL AT 3 M</b>								
NO.	FREQ. (MHz)	EMISSION LEVEL (dBuV/m)	LIMIT (dBuV/m)	MARGIN (dB)	ANTENNA HEIGHT (m)	TABLE ANGLE (Degree)	RAW VALUE (dBuV)	CORRECTION FACTOR (dB/m)
1	76.64	31.5 QP	40.0	-8.5	2.00 H	269	48.75	-17.29
2	111.08	33.2 QP	43.5	-10.3	1.50 H	95	49.36	-16.20
3	153.62	37.0 QP	43.5	-6.5	2.00 H	83	50.07	-13.05
4	375.03	38.2 QP	46.0	-7.8	1.00 H	85	48.39	-10.23
5	502.64	37.7 QP	46.0	-8.3	1.50 H	107	44.97	-7.30
6	1000.00	45.2 QP	54.0	-8.8	1.00 H	69	43.71	1.46
<b>ANTENNA POLARITY &amp; TEST DISTANCE: VERTICAL AT 3 M</b>								
NO.	FREQ. (MHz)	EMISSION LEVEL (dBuV/m)	LIMIT (dBuV/m)	MARGIN (dB)	ANTENNA HEIGHT (m)	TABLE ANGLE (Degree)	RAW VALUE (dBuV)	CORRECTION FACTOR (dB/m)
1	51.16	32.2 QP	40.0	-7.8	1.00 V	229	45.73	-13.57
2	76.21	33.4 QP	40.0	-6.6	1.00 V	351	50.48	-17.09
3	118.13	34.7 QP	43.5	-8.8	1.50 V	200	50.02	-15.31
4	153.23	33.8 QP	43.5	-9.7	1.00 V	338	46.90	-13.07
5	426.60	37.2 QP	46.0	-8.8	1.50 V	360	46.00	-8.80
6	1000.00	40.6 QP	54.0	-13.4	1.00 V	63	39.16	1.46

**REMARKS:**

1. Emission Level(dBuV/m) = Raw Value(dBuV) + Correction Factor(dB/m)
2. Correction Factor(dB/m) = Antenna Factor(dB/m) + Cable Factor(dB) – Pre-Amplifier Factor(dB)
3. The other emission levels were very low against the limit.
4. Margin value = Emission Level – Limit value



A D T

<b>CHANNEL</b>	TX Channel 40	<b>DETECTOR FUNCTION</b>	Quasi-Peak (QP)
<b>FREQUENCY RANGE</b>	Below 1GHz		

**ANTENNA POLARITY & TEST DISTANCE: HORIZONTAL AT 3 M**

NO.	FREQ. (MHz)	EMISSION LEVEL (dBuV/m)	LIMIT (dBuV/m)	MARGIN (dB)	ANTENNA HEIGHT (m)	TABLE ANGLE (Degree)	RAW VALUE (dBuV)	CORRECTION FACTOR (dB/m)
1	76.72	31.9 QP	40.0	-8.1	2.00 H	270	49.23	-17.32
2	111.08	32.9 QP	43.5	-10.6	1.50 H	99	49.13	-16.20
3	153.59	37.1 QP	43.5	-6.5	2.00 H	77	50.10	-13.05
4	374.88	37.9 QP	46.0	-8.1	1.00 H	83	48.11	-10.24
5	502.42	38.1 QP	46.0	-8.0	1.50 H	113	45.35	-7.30
6	1000.00	45.5 QP	54.0	-8.5	1.00 H	69	44.03	1.46

**ANTENNA POLARITY & TEST DISTANCE: VERTICAL AT 3 M**

NO.	FREQ. (MHz)	EMISSION LEVEL (dBuV/m)	LIMIT (dBuV/m)	MARGIN (dB)	ANTENNA HEIGHT (m)	TABLE ANGLE (Degree)	RAW VALUE (dBuV)	CORRECTION FACTOR (dB/m)
1	51.33	32.7 QP	40.0	-7.4	1.00 V	227	46.22	-13.57
2	76.17	33.7 QP	40.0	-6.3	1.00 V	345	50.75	-17.08
3	118.35	34.6 QP	43.5	-8.9	1.50 V	198	49.89	-15.30
4	153.32	34.1 QP	43.5	-9.4	1.00 V	341	47.12	-13.06
5	426.56	36.8 QP	46.0	-9.2	1.50 V	360	45.60	-8.80
6	1000.00	40.3 QP	54.0	-13.7	1.00 V	54	38.83	1.46

**REMARKS:**

1. Emission Level(dBuV/m) = Raw Value(dBuV) + Correction Factor(dB/m)
2. Correction Factor(dB/m) = Antenna Factor(dB/m) + Cable Factor(dB) – Pre-Amplifier Factor(dB)
3. The other emission levels were very low against the limit.
4. Margin value = Emission Level – Limit value



A D T

<b>CHANNEL</b>	TX Channel 48	<b>DETECTOR FUNCTION</b>	Quasi-Peak (QP)
<b>FREQUENCY RANGE</b>	Below 1GHz		

**ANTENNA POLARITY & TEST DISTANCE: HORIZONTAL AT 3 M**

NO.	FREQ. (MHz)	EMISSION LEVEL (dBuV/m)	LIMIT (dBuV/m)	MARGIN (dB)	ANTENNA HEIGHT (m)	TABLE ANGLE (Degree)	RAW VALUE (dBuV)	CORRECTION FACTOR (dB/m)
1	76.96	31.4 QP	40.0	-8.6	2.00 H	272	48.86	-17.43
2	110.96	33.3 QP	43.5	-10.2	1.50 H	96	49.49	-16.22
3	153.63	37.4 QP	43.5	-6.1	2.00 H	81	50.48	-13.05
4	374.73	37.5 QP	46.0	-8.5	1.00 H	75	47.77	-10.25
5	502.52	37.9 QP	46.0	-8.1	1.50 H	111	45.20	-7.30
6	1000.00	45.0 QP	54.0	-9.0	1.00 H	66	43.56	1.46

**ANTENNA POLARITY & TEST DISTANCE: VERTICAL AT 3 M**

NO.	FREQ. (MHz)	EMISSION LEVEL (dBuV/m)	LIMIT (dBuV/m)	MARGIN (dB)	ANTENNA HEIGHT (m)	TABLE ANGLE (Degree)	RAW VALUE (dBuV)	CORRECTION FACTOR (dB/m)
1	51.48	32.7 QP	40.0	-7.3	1.00 V	235	46.26	-13.57
2	76.09	33.3 QP	40.0	-6.7	1.00 V	352	50.33	-17.04
3	118.14	34.8 QP	43.5	-8.7	1.50 V	205	50.07	-15.31
4	153.37	33.9 QP	43.5	-9.6	1.00 V	338	46.97	-13.06
5	426.80	37.1 QP	46.0	-8.9	1.50 V	360	45.86	-8.80
6	1000.00	39.8 QP	54.0	-14.2	1.00 V	52	38.37	1.46

**REMARKS:**

1. Emission Level(dBuV/m) = Raw Value(dBuV) + Correction Factor(dB/m)
2. Correction Factor(dB/m) = Antenna Factor(dB/m) + Cable Factor(dB) – Pre-Amplifier Factor(dB)
3. The other emission levels were very low against the limit.
4. Margin value = Emission Level – Limit value



A D T

<b>CHANNEL</b>	TX Channel 149	<b>DETECTOR FUNCTION</b>	Quasi-Peak (QP)
<b>FREQUENCY RANGE</b>	Below 1GHz		

**ANTENNA POLARITY & TEST DISTANCE: HORIZONTAL AT 3 M**

NO.	FREQ. (MHz)	EMISSION LEVEL (dBuV/m)	LIMIT (dBuV/m)	MARGIN (dB)	ANTENNA HEIGHT (m)	TABLE ANGLE (Degree)	RAW VALUE (dBuV)	CORRECTION FACTOR (dB/m)
1	77.29	32.4 QP	40.0	-7.6	2.00 H	263	49.94	-17.57
2	110.83	34.6 QP	43.5	-8.9	1.50 H	87	50.84	-16.25
3	152.71	36.5 QP	43.5	-7.0	2.00 H	105	49.57	-13.09
4	375.00	37.1 QP	46.0	-8.9	1.00 H	61	47.35	-10.23
5	502.61	37.8 QP	46.0	-8.2	1.50 H	99	45.11	-7.30
6	1000.00	45.3 QP	54.0	-8.7	1.00 H	58	43.81	1.46

**ANTENNA POLARITY & TEST DISTANCE: VERTICAL AT 3 M**

NO.	FREQ. (MHz)	EMISSION LEVEL (dBuV/m)	LIMIT (dBuV/m)	MARGIN (dB)	ANTENNA HEIGHT (m)	TABLE ANGLE (Degree)	RAW VALUE (dBuV)	CORRECTION FACTOR (dB/m)
1	51.28	32.3 QP	40.0	-7.7	1.00 V	224	45.86	-13.56
2	<b>76.43</b>	<b>35.6 QP</b>	<b>40.0</b>	<b>-4.4</b>	<b>1.00 V</b>	<b>350</b>	<b>52.79</b>	<b>-17.19</b>
3	117.32	35.5 QP	43.5	-8.0	1.50 V	209	50.95	-15.44
4	152.94	33.7 QP	43.5	-9.8	1.00 V	321	46.75	-13.08
5	426.43	38.0 QP	46.0	-8.0	1.50 V	360	46.80	-8.81
6	1000.00	41.6 QP	54.0	-12.4	1.00 V	54	40.16	1.46

**REMARKS:**

1. Emission Level(dBuV/m) = Raw Value(dBuV) + Correction Factor(dB/m)
2. Correction Factor(dB/m) = Antenna Factor(dB/m) + Cable Factor(dB) – Pre-Amplifier Factor(dB)
3. The other emission levels were very low against the limit.
4. Margin value = Emission Level – Limit value





A D T

<b>CHANNEL</b>	TX Channel 157	<b>DETECTOR FUNCTION</b>	Quasi-Peak (QP)
<b>FREQUENCY RANGE</b>	Below 1GHz		

**ANTENNA POLARITY & TEST DISTANCE: HORIZONTAL AT 3 M**

NO.	FREQ. (MHz)	EMISSION LEVEL (dBuV/m)	LIMIT (dBuV/m)	MARGIN (dB)	ANTENNA HEIGHT (m)	TABLE ANGLE (Degree)	RAW VALUE (dBuV)	CORRECTION FACTOR (dB/m)
1	77.08	31.9 QP	40.0	-8.1	2.00 H	258	49.39	-17.47
2	110.85	35.0 QP	43.5	-8.5	1.50 H	80	51.25	-16.24
3	152.58	36.5 QP	43.5	-7.0	2.00 H	100	49.64	-13.10
4	374.82	37.2 QP	46.0	-8.8	1.00 H	57	47.43	-10.24
5	502.62	38.3 QP	46.0	-7.7	1.50 H	92	45.56	-7.30
6	1000.00	45.5 QP	54.0	-8.5	1.00 H	61	44.07	1.46

**ANTENNA POLARITY & TEST DISTANCE: VERTICAL AT 3 M**

NO.	FREQ. (MHz)	EMISSION LEVEL (dBuV/m)	LIMIT (dBuV/m)	MARGIN (dB)	ANTENNA HEIGHT (m)	TABLE ANGLE (Degree)	RAW VALUE (dBuV)	CORRECTION FACTOR (dB/m)
1	51.19	32.4 QP	40.0	-7.6	1.00 V	218	46.00	-13.57
2	76.51	35.6 QP	40.0	-4.4	1.00 V	340	52.79	-17.23
3	117.51	35.8 QP	43.5	-7.7	1.50 V	207	51.19	-15.40
4	153.04	33.6 QP	43.5	-10.0	1.00 V	312	46.63	-13.08
5	426.55	37.5 QP	46.0	-8.5	1.50 V	360	46.30	-8.80
6	1000.00	41.7 QP	54.0	-12.3	1.00 V	47	40.27	1.46

**REMARKS:**

1. Emission Level(dBuV/m) = Raw Value(dBuV) + Correction Factor(dB/m)
2. Correction Factor(dB/m) = Antenna Factor(dB/m) + Cable Factor(dB) – Pre-Amplifier Factor(dB)
3. The other emission levels were very low against the limit.
4. Margin value = Emission Level – Limit value



A D T

<b>CHANNEL</b>	TX Channel 165	<b>DETECTOR FUNCTION</b>	Quasi-Peak (QP)
<b>FREQUENCY RANGE</b>	Below 1GHz		

**ANTENNA POLARITY & TEST DISTANCE: HORIZONTAL AT 3 M**

NO.	FREQ. (MHz)	EMISSION LEVEL (dBuV/m)	LIMIT (dBuV/m)	MARGIN (dB)	ANTENNA HEIGHT (m)	TABLE ANGLE (Degree)	RAW VALUE (dBuV)	CORRECTION FACTOR (dB/m)
1	77.03	32.4 QP	40.0	-7.6	2.00 H	263	49.86	-17.46
2	111.03	35.5 QP	43.5	-8.0	1.50 H	83	51.67	-16.21
3	152.38	37.0 QP	43.5	-6.5	2.00 H	92	50.13	-13.11
4	375.04	36.7 QP	46.0	-9.3	1.00 H	49	46.96	-10.23
5	502.67	37.8 QP	46.0	-8.2	1.50 H	83	45.11	-7.30
6	1000.00	45.5 QP	54.0	-8.6	1.00 H	53	43.99	1.46

**ANTENNA POLARITY & TEST DISTANCE: VERTICAL AT 3 M**

NO.	FREQ. (MHz)	EMISSION LEVEL (dBuV/m)	LIMIT (dBuV/m)	MARGIN (dB)	ANTENNA HEIGHT (m)	TABLE ANGLE (Degree)	RAW VALUE (dBuV)	CORRECTION FACTOR (dB/m)
1	51.24	32.9 QP	40.0	-7.1	1.00 V	218	46.45	-13.57
2	76.66	35.2 QP	40.0	-4.8	1.00 V	344	52.46	-17.30
3	117.39	35.6 QP	43.5	-7.9	1.50 V	202	50.99	-15.43
4	152.92	34.0 QP	43.5	-9.5	1.00 V	320	47.12	-13.08
5	426.66	38.0 QP	46.0	-8.0	1.50 V	360	46.79	-8.80
6	1000.00	41.8 QP	54.0	-12.2	1.00 V	55	40.35	1.46

**REMARKS:**

1. Emission Level(dBuV/m) = Raw Value(dBuV) + Correction Factor(dB/m)
2. Correction Factor(dB/m) = Antenna Factor(dB/m) + Cable Factor(dB) – Pre-Amplifier Factor(dB)
3. The other emission levels were very low against the limit.
4. Margin value = Emission Level – Limit value



A D T

802.11ac (VHT40)

<b>CHANNEL</b>	TX Channel 38	<b>DETECTOR FUNCTION</b>	Quasi-Peak (QP)
<b>FREQUENCY RANGE</b>	Below 1GHz		

**ANTENNA POLARITY & TEST DISTANCE: HORIZONTAL AT 3 M**

NO.	FREQ. (MHz)	EMISSION LEVEL (dBuV/m)	LIMIT (dBuV/m)	MARGIN (dB)	ANTENNA HEIGHT (m)	TABLE ANGLE (Degree)	RAW VALUE (dBuV)	CORRECTION FACTOR (dB/m)
1	76.79	31.7 QP	40.0	-8.3	2.00 H	270	49.01	-17.35
2	111.21	33.6 QP	43.5	-10.0	1.50 H	93	49.74	-16.19
3	153.46	37.5 QP	43.5	-6.0	2.00 H	82	50.52	-13.06
4	374.72	37.5 QP	46.0	-8.5	1.00 H	82	47.77	-10.25
5	502.33	38.2 QP	46.0	-7.8	1.50 H	107	45.51	-7.30
6	1000.00	44.9 QP	54.0	-9.1	1.00 H	75	43.47	1.46

**ANTENNA POLARITY & TEST DISTANCE: VERTICAL AT 3 M**

NO.	FREQ. (MHz)	EMISSION LEVEL (dBuV/m)	LIMIT (dBuV/m)	MARGIN (dB)	ANTENNA HEIGHT (m)	TABLE ANGLE (Degree)	RAW VALUE (dBuV)	CORRECTION FACTOR (dB/m)
1	51.58	32.2 QP	40.0	-7.8	1.00 V	228	45.80	-13.58
2	76.13	33.3 QP	40.0	-6.7	1.00 V	346	50.40	-17.06
3	118.17	34.7 QP	43.5	-8.8	1.50 V	214	50.00	-15.30
4	153.36	33.6 QP	43.5	-9.9	1.00 V	342	46.70	-13.06
5	427.02	37.2 QP	46.0	-8.8	1.50 V	360	45.95	-8.79
6	1000.00	39.7 QP	54.0	-14.3	1.00 V	48	38.27	1.46

**REMARKS:**

1. Emission Level(dBuV/m) = Raw Value(dBuV) + Correction Factor(dB/m)
2. Correction Factor(dB/m) = Antenna Factor(dB/m) + Cable Factor(dB) – Pre-Amplifier Factor(dB)
3. The other emission levels were very low against the limit.
4. Margin value = Emission Level – Limit value



A D T

<b>CHANNEL</b>	TX Channel 46	<b>DETECTOR FUNCTION</b>	Quasi-Peak (QP)
<b>FREQUENCY RANGE</b>	Below 1GHz		

**ANTENNA POLARITY & TEST DISTANCE: HORIZONTAL AT 3 M**

NO.	FREQ. (MHz)	EMISSION LEVEL (dBuV/m)	LIMIT (dBuV/m)	MARGIN (dB)	ANTENNA HEIGHT (m)	TABLE ANGLE (Degree)	RAW VALUE (dBuV)	CORRECTION FACTOR (dB/m)
1	77.03	31.8 QP	40.0	-8.2	2.00 H	269	49.24	-17.45
2	111.14	34.1 QP	43.5	-9.5	1.50 H	98	50.25	-16.20
3	153.68	37.5 QP	43.5	-6.1	2.00 H	80	50.50	-13.05
4	374.83	37.9 QP	46.0	-8.1	1.00 H	83	48.11	-10.24
5	502.54	37.8 QP	46.0	-8.3	1.50 H	113	45.05	-7.30
6	1000.00	45.0 QP	54.0	-9.0	1.00 H	70	43.57	1.46

**ANTENNA POLARITY & TEST DISTANCE: VERTICAL AT 3 M**

NO.	FREQ. (MHz)	EMISSION LEVEL (dBuV/m)	LIMIT (dBuV/m)	MARGIN (dB)	ANTENNA HEIGHT (m)	TABLE ANGLE (Degree)	RAW VALUE (dBuV)	CORRECTION FACTOR (dB/m)
1	51.37	32.7 QP	40.0	-7.3	1.00 V	220	46.27	-13.57
2	76.02	33.2 QP	40.0	-6.8	1.00 V	340	50.20	-17.01
3	118.37	34.3 QP	43.5	-9.2	1.50 V	224	49.56	-15.30
4	153.48	34.1 QP	43.5	-9.4	1.00 V	348	47.18	-13.06
5	427.05	37.5 QP	46.0	-8.5	1.50 V	360	46.30	-8.79
6	1000.00	39.5 QP	54.0	-14.5	1.00 V	39	38.06	1.46

**REMARKS:**

1. Emission Level(dBuV/m) = Raw Value(dBuV) + Correction Factor(dB/m)
2. Correction Factor(dB/m) = Antenna Factor(dB/m) + Cable Factor(dB) – Pre-Amplifier Factor(dB)
3. The other emission levels were very low against the limit.
4. Margin value = Emission Level – Limit value



A D T

<b>CHANNEL</b>	TX Channel 151	<b>DETECTOR FUNCTION</b>	Quasi-Peak (QP)
<b>FREQUENCY RANGE</b>	Below 1GHz		

**ANTENNA POLARITY & TEST DISTANCE: HORIZONTAL AT 3 M**

NO.	FREQ. (MHz)	EMISSION LEVEL (dBuV/m)	LIMIT (dBuV/m)	MARGIN (dB)	ANTENNA HEIGHT (m)	TABLE ANGLE (Degree)	RAW VALUE (dBuV)	CORRECTION FACTOR (dB/m)
1	76.89	32.5 QP	40.0	-7.5	2.00 H	257	49.89	-17.40
2	111.17	35.2 QP	43.5	-8.3	1.50 H	89	51.37	-16.19
3	152.62	36.9 QP	43.5	-6.6	2.00 H	98	49.97	-13.10
4	374.85	36.6 QP	46.0	-9.4	1.00 H	47	46.85	-10.24
5	502.67	38.3 QP	46.0	-7.7	1.50 H	78	45.60	-7.30
6	1000.00	45.1 QP	54.0	-8.9	1.00 H	49	43.67	1.46

**ANTENNA POLARITY & TEST DISTANCE: VERTICAL AT 3 M**

NO.	FREQ. (MHz)	EMISSION LEVEL (dBuV/m)	LIMIT (dBuV/m)	MARGIN (dB)	ANTENNA HEIGHT (m)	TABLE ANGLE (Degree)	RAW VALUE (dBuV)	CORRECTION FACTOR (dB/m)
1	51.29	32.6 QP	40.0	-7.4	1.00 V	218	46.14	-13.57
2	76.42	35.2 QP	40.0	-4.8	1.00 V	339	52.38	-17.19
3	117.50	35.4 QP	43.5	-8.1	1.50 V	212	50.79	-15.40
4	152.82	34.4 QP	43.5	-9.1	1.00 V	325	47.51	-13.09
5	426.41	38.0 QP	46.0	-8.1	1.50 V	360	46.76	-8.81
6	1000.00	41.7 QP	54.0	-12.3	1.00 V	51	40.23	1.46

**REMARKS:**

1. Emission Level(dBuV/m) = Raw Value(dBuV) + Correction Factor(dB/m)
2. Correction Factor(dB/m) = Antenna Factor(dB/m) + Cable Factor(dB) – Pre-Amplifier Factor(dB)
3. The other emission levels were very low against the limit.
4. Margin value = Emission Level – Limit value



A D T

<b>CHANNEL</b>	TX Channel 159	<b>DETECTOR FUNCTION</b>	Quasi-Peak (QP)
<b>FREQUENCY RANGE</b>	Below 1GHz		

**ANTENNA POLARITY & TEST DISTANCE: HORIZONTAL AT 3 M**

NO.	FREQ. (MHz)	EMISSION LEVEL (dBuV/m)	LIMIT (dBuV/m)	MARGIN (dB)	ANTENNA HEIGHT (m)	TABLE ANGLE (Degree)	RAW VALUE (dBuV)	CORRECTION FACTOR (dB/m)
1	76.95	33.0 QP	40.0	-7.0	2.00 H	240	50.47	-17.43
2	110.99	35.6 QP	43.5	-7.9	1.50 H	78	51.80	-16.22
3	152.75	36.4 QP	43.5	-7.1	2.00 H	93	49.53	-13.09
4	374.87	36.6 QP	46.0	-9.5	1.00 H	55	46.79	-10.24
5	502.46	38.1 QP	46.0	-7.9	1.50 H	88	45.44	-7.30
6	1000.00	45.8 QP	54.0	-8.2	1.00 H	58	44.33	1.46

**ANTENNA POLARITY & TEST DISTANCE: VERTICAL AT 3 M**

NO.	FREQ. (MHz)	EMISSION LEVEL (dBuV/m)	LIMIT (dBuV/m)	MARGIN (dB)	ANTENNA HEIGHT (m)	TABLE ANGLE (Degree)	RAW VALUE (dBuV)	CORRECTION FACTOR (dB/m)
1	51.30	32.4 QP	40.0	-7.6	1.00 V	217	46.01	-13.57
2	76.31	34.7 QP	40.0	-5.3	1.00 V	351	51.83	-17.14
3	117.69	35.5 QP	43.5	-8.0	1.50 V	209	50.90	-15.36
4	152.87	34.6 QP	43.5	-8.9	1.00 V	315	47.66	-13.09
5	426.44	37.9 QP	46.0	-8.1	1.50 V	360	46.69	-8.81
6	1000.00	41.6 QP	54.0	-12.4	1.00 V	53	40.17	1.46

**REMARKS:**

1. Emission Level(dBuV/m) = Raw Value(dBuV) + Correction Factor(dB/m)
2. Correction Factor(dB/m) = Antenna Factor(dB/m) + Cable Factor(dB) – Pre-Amplifier Factor(dB)
3. The other emission levels were very low against the limit.
4. Margin value = Emission Level – Limit value



A D T

802.11ac (VHT80)

<b>CHANNEL</b>	TX Channel 42	<b>DETECTOR FUNCTION</b>	Quasi-Peak (QP)
<b>FREQUENCY RANGE</b>	Below 1GHz		

**ANTENNA POLARITY & TEST DISTANCE: HORIZONTAL AT 3 M**

NO.	FREQ. (MHz)	EMISSION LEVEL (dBuV/m)	LIMIT (dBuV/m)	MARGIN (dB)	ANTENNA HEIGHT (m)	TABLE ANGLE (Degree)	RAW VALUE (dBuV)	CORRECTION FACTOR (dB/m)
1	77.19	31.8 QP	40.0	-8.2	2.00 H	260	49.31	-17.52
2	111.15	33.8 QP	43.5	-9.7	1.50 H	105	49.95	-16.19
3	153.54	37.7 QP	43.5	-5.8	2.00 H	76	50.79	-13.05
4	374.62	37.5 QP	46.0	-8.5	1.00 H	73	47.78	-10.25
5	502.45	38.0 QP	46.0	-8.0	1.50 H	120	45.32	-7.30
6	1000.00	44.6 QP	54.0	-9.4	1.00 H	79	43.10	1.46

**ANTENNA POLARITY & TEST DISTANCE: VERTICAL AT 3 M**

NO.	FREQ. (MHz)	EMISSION LEVEL (dBuV/m)	LIMIT (dBuV/m)	MARGIN (dB)	ANTENNA HEIGHT (m)	TABLE ANGLE (Degree)	RAW VALUE (dBuV)	CORRECTION FACTOR (dB/m)
1	51.29	32.5 QP	40.0	-7.5	1.00 V	222	46.06	-13.57
2	76.05	33.0 QP	40.0	-7.0	1.00 V	331	50.03	-17.02
3	118.59	34.1 QP	43.5	-9.4	1.50 V	226	49.35	-15.29
4	153.40	34.2 QP	43.5	-9.3	1.00 V	353	47.25	-13.06
5	427.13	37.1 QP	46.0	-8.9	1.50 V	360	45.93	-8.79
6	1000.00	39.8 QP	54.0	-14.2	1.00 V	47	38.37	1.46

**REMARKS:**

1. Emission Level(dBuV/m) = Raw Value(dBuV) + Correction Factor(dB/m)
2. Correction Factor(dB/m) = Antenna Factor(dB/m) + Cable Factor(dB) – Pre-Amplifier Factor(dB)
3. The other emission levels were very low against the limit.
4. Margin value = Emission Level – Limit value



A D T

<b>CHANNEL</b>	TX Channel 155	<b>DETECTOR FUNCTION</b>	Quasi-Peak (QP)
<b>FREQUENCY RANGE</b>	Below 1GHz		

**ANTENNA POLARITY & TEST DISTANCE: HORIZONTAL AT 3 M**

NO.	FREQ. (MHz)	EMISSION LEVEL (dBuV/m)	LIMIT (dBuV/m)	MARGIN (dB)	ANTENNA HEIGHT (m)	TABLE ANGLE (Degree)	RAW VALUE (dBuV)	CORRECTION FACTOR (dB/m)
1	77.19	33.5 QP	40.0	-6.5	2.00 H	238	51.00	-17.52
2	110.74	36.0 QP	43.5	-7.5	1.50 H	75	52.29	-16.26
3	152.60	36.7 QP	43.5	-6.9	2.00 H	88	49.75	-13.10
4	374.76	36.8 QP	46.0	-9.2	1.00 H	47	47.07	-10.24
5	502.37	38.0 QP	46.0	-8.0	1.50 H	89	45.31	-7.30
6	1000.00	46.0 QP	54.0	-8.0	1.00 H	68	44.58	1.46

**ANTENNA POLARITY & TEST DISTANCE: VERTICAL AT 3 M**

NO.	FREQ. (MHz)	EMISSION LEVEL (dBuV/m)	LIMIT (dBuV/m)	MARGIN (dB)	ANTENNA HEIGHT (m)	TABLE ANGLE (Degree)	RAW VALUE (dBuV)	CORRECTION FACTOR (dB/m)
1	51.54	32.3 QP	40.0	-7.7	1.00 V	224	45.86	-13.57
2	76.47	34.4 QP	40.0	-5.6	1.00 V	359	51.59	-17.21
3	117.73	35.7 QP	43.5	-7.8	1.50 V	201	51.06	-15.36
4	152.96	34.9 QP	43.5	-8.6	1.00 V	313	47.98	-13.08
5	426.69	37.8 QP	46.0	-8.2	1.50 V	360	46.60	-8.80
6	1000.00	41.9 QP	54.0	-12.1	1.00 V	45	40.40	1.46

**REMARKS:**

1. Emission Level(dBuV/m) = Raw Value(dBuV) + Correction Factor(dB/m)
2. Correction Factor(dB/m) = Antenna Factor(dB/m) + Cable Factor(dB) – Pre-Amplifier Factor(dB)
3. The other emission levels were very low against the limit.
4. Margin value = Emission Level – Limit value



## ABOVE 1GHz DATA

### 802.11a

<b>CHANNEL</b>	TX Channel 36	<b>DETECTOR FUNCTION</b>	Peak (PK)
<b>FREQUENCY RANGE</b>	1GHz ~ 40GHz		Average (AV)

#### ANTENNA POLARITY & TEST DISTANCE: HORIZONTAL AT 3 M

NO.	FREQ. (MHz)	EMISSION LEVEL (dBuV/m)	LIMIT (dBuV/m)	MARGIN (dB)	ANTENNA HEIGHT (m)	TABLE ANGLE (Degree)	RAW VALUE (dBuV)	CORRECTION FACTOR (dB/m)
1	5150.00	53.6 PK	74.0	-20.4	1.00 H	163	13.04	40.56
2	5150.00	40.9 AV	54.0	-13.1	1.00 H	163	0.34	40.56
3	*5180.00	102.1 PK			1.00 H	163	61.46	40.64
4	*5180.00	93.1 AV			1.00 H	163	52.46	40.64
5	#6996.67	55.4 PK	74.0	-18.6	1.01 H	213	11.57	43.83
6	#6996.67	48.9 AV	54.0	-5.1	1.01 H	213	5.07	43.83
7	#10360.00	53.8 PK	74.0	-20.2	1.32 H	301	7.05	46.75
8	#10360.00	41.8 AV	54.0	-12.2	1.32 H	301	-4.95	46.75
9	15540.00	61.6 PK	74.0	-12.4	1.01 H	255	10.40	51.20
10	15540.00	47.7 AV	54.0	-6.3	1.01 H	255	-3.50	51.20

#### ANTENNA POLARITY & TEST DISTANCE: VERTICAL AT 3 M

NO.	FREQ. (MHz)	EMISSION LEVEL (dBuV/m)	LIMIT (dBuV/m)	MARGIN (dB)	ANTENNA HEIGHT (m)	TABLE ANGLE (Degree)	RAW VALUE (dBuV)	CORRECTION FACTOR (dB/m)
1	5150.00	70.8 PK	74.0	-3.2	1.08 V	168	30.24	40.56
2	5150.00	53.0 AV	54.0	-1.0	1.08 V	168	12.44	40.56
3	*5180.00	115.7 PK			1.08 V	168	75.06	40.64
4	*5180.00	106.4 AV			1.08 V	168	65.76	40.64
5	#6996.67	56.3 PK	74.0	-17.7	1.00 V	176	12.47	43.83
6	#6996.67	50.9 AV	54.0	-3.1	1.00 V	176	7.07	43.83
7	#10360.00	54.0 PK	74.0	-20.0	1.00 V	212	7.25	46.75
8	#10360.00	41.3 AV	54.0	-12.7	1.00 V	212	-5.45	46.75
9	15540.00	59.9 PK	74.0	-14.1	1.00 V	157	8.70	51.20
10	15540.00	47.4 AV	54.0	-6.6	1.00 V	157	-3.80	51.20

#### REMARKS:

1. Emission Level(dBuV/m) = Raw Value(dBuV) + Correction Factor(dB/m)
2. Correction Factor(dB/m) = Antenna Factor(dB/m) + Cable Factor(dB) – Pre-Amplifier Factor(dB)
3. The other emission levels were very low against the limit.
4. Margin value = Emission Level – Limit value
5. " \* ": Fundamental frequency.
6. " # ": The radiated frequency is out of the restricted band.



A D T

<b>CHANNEL</b>	TX Channel 40	<b>DETECTOR FUNCTION</b>	Peak (PK)
<b>FREQUENCY RANGE</b>	1GHz ~ 40GHz		Average (AV)

**ANTENNA POLARITY & TEST DISTANCE: HORIZONTAL AT 3 M**

NO.	FREQ. (MHz)	EMISSION LEVEL (dBuV/m)	LIMIT (dBuV/m)	MARGIN (dB)	ANTENNA HEIGHT (m)	TABLE ANGLE (Degree)	RAW VALUE (dBuV)	CORRECTION FACTOR (dB/m)
1	5150.00	54.3 PK	74.0	-19.7	1.00 H	162	13.74	40.56
2	5150.00	34.0 AV	54.0	-20.0	1.00 H	162	-6.56	40.56
3	*5200.00	105.2 PK			1.00 H	162	64.52	40.68
4	*5200.00	97.6 AV			1.00 H	162	56.92	40.68
5	#6933.00	53.2 PK	74.0	-20.8	1.00 H	162	9.42	43.78
6	#6933.00	44.7 AV	54.0	-9.3	1.00 H	162	0.92	43.78
7	#10400.00	58.6 PK	74.0	-15.4	1.27 H	257	11.89	46.71
8	#10400.00	44.6 AV	54.0	-9.4	1.27 H	257	-2.11	46.71
9	15600.00	63.4 PK	74.0	-10.6	1.02 H	263	12.12	51.28
10	15600.00	49.6 AV	54.0	-4.4	1.02 H	263	-1.68	51.28

**ANTENNA POLARITY & TEST DISTANCE: VERTICAL AT 3 M**

NO.	FREQ. (MHz)	EMISSION LEVEL (dBuV/m)	LIMIT (dBuV/m)	MARGIN (dB)	ANTENNA HEIGHT (m)	TABLE ANGLE (Degree)	RAW VALUE (dBuV)	CORRECTION FACTOR (dB/m)
1	5150.00	55.2 PK	74.0	-18.8	1.07 V	183	14.64	40.56
2	5150.00	46.1 AV	54.0	-7.9	1.07 V	183	5.54	40.56
3	*5200.00	118.7 PK			1.02 V	188	78.02	40.68
4	*5200.00	110.8 AV			1.02 V	188	70.12	40.68
5	#6933.00	54.9 PK	74.0	-19.1	1.05 V	176	11.12	43.78
6	#6933.00	46.3 AV	54.0	-7.7	1.05 V	176	2.52	43.78
7	#10400.00	58.3 PK	74.0	-15.7	1.02 V	217	11.59	46.71
8	#10400.00	44.3 AV	54.0	-9.7	1.02 V	217	-2.41	46.71
9	15600.00	61.2 PK	74.0	-12.8	1.02 V	146	9.92	51.28
10	15600.00	49.2 AV	54.0	-4.8	1.02 V	146	-2.08	51.28

**REMARKS:**

1. Emission Level(dBuV/m) = Raw Value(dBuV) + Correction Factor(dB/m)
2. Correction Factor(dB/m) = Antenna Factor(dB/m) + Cable Factor(dB) – Pre-Amplifier Factor(dB)
3. The other emission levels were very low against the limit.
4. Margin value = Emission Level – Limit value
5. " \* ": Fundamental frequency.
6. " # ": The radiated frequency is out of the restricted band.

<b>CHANNEL</b>	TX Channel 48	<b>DETECTOR FUNCTION</b>	Peak (PK)
<b>FREQUENCY RANGE</b>	1GHz ~ 40GHz		Average (AV)

ANTENNA POLARITY & TEST DISTANCE: HORIZONTAL AT 3 M								
NO.	FREQ. (MHz)	EMISSION LEVEL (dBuV/m)	LIMIT (dBuV/m)	MARGIN (dB)	ANTENNA HEIGHT (m)	TABLE ANGLE (Degree)	RAW VALUE (dBuV)	CORRECTION FACTOR (dB/m)
1	*5240.00	105.4 PK			1.00 H	157	64.65	40.75
2	*5240.00	97.5 AV			1.00 H	157	56.75	40.75
3	5350.00	54.5 PK	74.0	-19.5	1.05 H	154	13.56	40.94
4	5350.00	34.3 AV	54.0	-19.7	1.05 H	154	-6.64	40.94
5	#10480.00	58.6 PK	74.0	-15.4	1.27 H	210	11.80	46.80
6	#10480.00	44.8 AV	54.0	-9.2	1.27 H	210	-2.00	46.80
7	15720.00	63.0 PK	74.0	-11.0	1.02 H	253	11.66	51.34
8	15720.00	49.0 AV	54.0	-5.0	1.02 H	253	-2.34	51.34

ANTENNA POLARITY & TEST DISTANCE: VERTICAL AT 3 M								
NO.	FREQ. (MHz)	EMISSION LEVEL (dBuV/m)	LIMIT (dBuV/m)	MARGIN (dB)	ANTENNA HEIGHT (m)	TABLE ANGLE (Degree)	RAW VALUE (dBuV)	CORRECTION FACTOR (dB/m)
1	*5240.00	117.9 PK			1.05 V	194	77.15	40.75
2	*5240.00	110.8 AV			1.05 V	194	70.05	40.75
3	5350.00	54.0 PK	74.0	-20.0	1.05 V	194	13.06	40.94
4	5350.00	43.9 AV	54.0	-10.1	1.05 V	194	2.96	40.94
5	#10480.00	58.2 PK	74.0	-15.8	1.00 V	206	11.40	46.80
6	#10480.00	44.1 AV	54.0	-9.9	1.00 V	206	-2.70	46.80
7	15720.00	60.7 PK	74.0	-13.3	1.06 V	148	9.36	51.34
8	15720.00	48.8 AV	54.0	-5.2	1.06 V	148	-2.54	51.34

**REMARKS:**

1. Emission Level(dBuV/m) = Raw Value(dBuV) + Correction Factor(dB/m)
2. Correction Factor(dB/m) = Antenna Factor(dB/m) + Cable Factor(dB) – Pre-Amplifier Factor(dB)
3. The other emission levels were very low against the limit.
4. Margin value = Emission Level – Limit value
5. " \* ": Fundamental frequency.
6. " # ": The radiated frequency is out of the restricted band.



A D T

<b>CHANNEL</b>	TX Channel 149	<b>DETECTOR FUNCTION</b>	Peak (PK)
<b>FREQUENCY RANGE</b>	1GHz ~ 40GHz		Average (AV)

**ANTENNA POLARITY & TEST DISTANCE: HORIZONTAL AT 3 M**

NO.	FREQ. (MHz)	EMISSION LEVEL (dBuV/m)	LIMIT (dBuV/m)	MARGIN (dB)	ANTENNA HEIGHT (m)	TABLE ANGLE (Degree)	RAW VALUE (dBuV)	CORRECTION FACTOR (dB/m)
1	#5725.00	52.8 PK	78.2	-25.4	1.01 H	163	44.41	8.39
2	*5745.00	101.3 PK			1.02 H	155	92.88	8.42
3	*5745.00	92.4 AV			1.02 H	155	83.98	8.42
4	11490.00	53.3 PK	74.0	-20.7	1.37 H	302	38.95	14.35
5	11490.00	41.2 AV	54.0	-12.8	1.37 H	302	26.85	14.35
6	#17235.00	61.4 PK	74.0	-12.6	1.04 H	256	38.96	22.44
7	#17235.00	47.2 AV	54.0	-6.8	1.04 H	256	24.76	22.44

**ANTENNA POLARITY & TEST DISTANCE: VERTICAL AT 3 M**

NO.	FREQ. (MHz)	EMISSION LEVEL (dBuV/m)	LIMIT (dBuV/m)	MARGIN (dB)	ANTENNA HEIGHT (m)	TABLE ANGLE (Degree)	RAW VALUE (dBuV)	CORRECTION FACTOR (dB/m)
1	#5725.00	76.6 PK	78.2	-1.6	1.17 V	173	68.21	8.39
2	*5745.00	113.2 PK			1.07 V	168	104.78	8.42
3	*5745.00	103.7 AV			1.07 V	168	95.28	8.42
4	11490.00	53.9 PK	74.0	-20.1	1.00 V	209	39.55	14.35
5	11490.00	41.2 AV	54.0	-12.8	1.00 V	209	26.85	14.35
6	#17235.00	59.2 PK	74.0	-14.8	1.00 V	146	36.76	22.44
7	#17235.00	47.1 AV	54.0	-6.9	1.00 V	146	24.66	22.44

**REMARKS:**

1. Emission Level(dBuV/m) = Raw Value(dBuV) + Correction Factor(dB/m)
2. Correction Factor(dB/m) = Antenna Factor(dB/m) + Cable Factor(dB) – Pre-Amplifier Factor(dB)
3. The other emission levels were very low against the limit.
4. Margin value = Emission Level – Limit value
5. " \* ": Fundamental frequency.
6. " # ": The radiated frequency is out of the restricted band.



A D T

<b>CHANNEL</b>	TX Channel 157	<b>DETECTOR FUNCTION</b>	Peak (PK)
<b>FREQUENCY RANGE</b>	1GHz ~ 40GHz		Average (AV)

**ANTENNA POLARITY & TEST DISTANCE: HORIZONTAL AT 3 M**

NO.	FREQ. (MHz)	EMISSION LEVEL (dBuV/m)	LIMIT (dBuV/m)	MARGIN (dB)	ANTENNA HEIGHT (m)	TABLE ANGLE (Degree)	RAW VALUE (dBuV)	CORRECTION FACTOR (dB/m)
1	*5785.00	105.3 PK			1.10 H	143	96.81	8.49
2	*5785.00	97.9 AV			1.10 H	143	89.41	8.49
3	11570.00	58.2 PK	74.0	-15.8	1.20 H	273	43.89	14.31
4	11570.00	44.4 AV	54.0	-9.6	1.20 H	273	30.09	14.31
5	#17355.00	63.1 PK	74.0	-10.9	1.02 H	262	40.10	23.00
6	#17355.00	49.5 AV	54.0	-4.5	1.02 H	262	26.50	23.00

**ANTENNA POLARITY & TEST DISTANCE: VERTICAL AT 3 M**

NO.	FREQ. (MHz)	EMISSION LEVEL (dBuV/m)	LIMIT (dBuV/m)	MARGIN (dB)	ANTENNA HEIGHT (m)	TABLE ANGLE (Degree)	RAW VALUE (dBuV)	CORRECTION FACTOR (dB/m)
1	*5785.00	118.2 PK			1.05 V	178	109.71	8.49
2	*5785.00	110.3 AV			1.05 V	178	101.81	8.49
3	11570.00	57.5 PK	74.0	-16.5	1.05 V	225	43.19	14.31
4	11570.00	43.8 AV	54.0	-10.2	1.05 V	225	29.49	14.31
5	#17355.00	61.4 PK	74.0	-12.6	1.00 V	156	38.40	23.00
6	#17355.00	49.6 AV	54.0	-4.4	1.00 V	156	26.60	23.00

**REMARKS:**

1. Emission Level(dBuV/m) = Raw Value(dBuV) + Correction Factor(dB/m)
2. Correction Factor(dB/m) = Antenna Factor(dB/m) + Cable Factor(dB) – Pre-Amplifier Factor(dB)
3. The other emission levels were very low against the limit.
4. Margin value = Emission Level – Limit value
5. " \* ": Fundamental frequency.
6. " # ": The radiated frequency is out of the restricted band.



A D T

<b>CHANNEL</b>	TX Channel 165	<b>DETECTOR FUNCTION</b>	Peak (PK)
<b>FREQUENCY RANGE</b>	1GHz ~ 40GHz		Average (AV)

**ANTENNA POLARITY & TEST DISTANCE: HORIZONTAL AT 3 M**

NO.	FREQ. (MHz)	EMISSION LEVEL (dBuV/m)	LIMIT (dBuV/m)	MARGIN (dB)	ANTENNA HEIGHT (m)	TABLE ANGLE (Degree)	RAW VALUE (dBuV)	CORRECTION FACTOR (dB/m)
1	*5825.00	105.0 PK			1.04 H	134	63.38	41.62
2	*5825.00	97.7 AV			1.04 H	134	56.08	41.62
3	#5850.00	51.3 PK	78.2	-26.9	1.04 H	134	9.62	41.68
4	11650.00	57.7 PK	74.0	-16.3	1.19 H	270	10.47	47.23
5	11650.00	43.9 AV	54.0	-10.1	1.19 H	270	-3.33	47.23
6	#17475.00	63.6 PK	74.0	-10.4	1.00 H	272	8.29	55.31
7	#17475.00	49.8 AV	54.0	-4.2	1.00 H	272	-5.51	55.31

**ANTENNA POLARITY & TEST DISTANCE: VERTICAL AT 3 M**

NO.	FREQ. (MHz)	EMISSION LEVEL (dBuV/m)	LIMIT (dBuV/m)	MARGIN (dB)	ANTENNA HEIGHT (m)	TABLE ANGLE (Degree)	RAW VALUE (dBuV)	CORRECTION FACTOR (dB/m)
1	*5825.00	117.6 PK			1.01 V	187	75.98	41.62
2	*5825.00	109.8 AV			1.01 V	187	68.18	41.62
3	#5850.00	75.0 PK	78.2	-3.2	1.13 V	197	33.32	41.68
4	11650.00	57.9 PK	74.0	-16.1	1.07 V	228	10.67	47.23
5	11650.00	44.2 AV	54.0	-9.8	1.07 V	228	-3.03	47.23
6	#17475.00	60.9 PK	74.0	-13.1	1.00 V	150	5.59	55.31
7	#17475.00	49.1 AV	54.0	-4.9	1.00 V	150	-6.21	55.31

**REMARKS:**

1. Emission Level(dBuV/m) = Raw Value(dBuV) + Correction Factor(dB/m)
2. Correction Factor(dB/m) = Antenna Factor(dB/m) + Cable Factor(dB) – Pre-Amplifier Factor(dB)
3. The other emission levels were very low against the limit.
4. Margin value = Emission Level – Limit value
5. " \* ": Fundamental frequency.
6. " # ": The radiated frequency is out of the restricted band.



A D T

802.11ac (VHT20)

<b>CHANNEL</b>	TX Channel 36	<b>DETECTOR FUNCTION</b>	Peak (PK)
<b>FREQUENCY RANGE</b>	1GHz ~ 40GHz		Average (AV)

**ANTENNA POLARITY & TEST DISTANCE: HORIZONTAL AT 3 M**

NO.	FREQ. (MHz)	EMISSION LEVEL (dBuV/m)	LIMIT (dBuV/m)	MARGIN (dB)	ANTENNA HEIGHT (m)	TABLE ANGLE (Degree)	RAW VALUE (dBuV)	CORRECTION FACTOR (dB/m)
1	5150.00	66.4 PK	74.0	-7.6	1.01 H	153	25.84	40.56
2	5150.00	40.3 AV	54.0	-13.7	1.01 H	153	-0.26	40.56
3	*5180.00	101.3 PK			1.01 H	153	60.66	40.64
4	*5180.00	92.4 AV			1.01 H	153	51.76	40.64
5	#10360.00	54.4 PK	74.0	-19.6	1.32 H	281	7.65	46.75
6	#10360.00	42.1 AV	54.0	-11.9	1.32 H	281	-4.65	46.75
7	15540.00	62.0 PK	74.0	-12.0	1.02 H	242	10.80	51.20
8	15540.00	48.0 AV	54.0	-6.0	1.02 H	242	-3.20	51.20

**ANTENNA POLARITY & TEST DISTANCE: VERTICAL AT 3 M**

NO.	FREQ. (MHz)	EMISSION LEVEL (dBuV/m)	LIMIT (dBuV/m)	MARGIN (dB)	ANTENNA HEIGHT (m)	TABLE ANGLE (Degree)	RAW VALUE (dBuV)	CORRECTION FACTOR (dB/m)
1	5150.00	68.7 PK	74.0	-5.3	1.06 V	170	28.14	40.56
2	5150.00	52.4 AV	54.0	-1.6	1.06 V	170	11.84	40.56
3	*5180.00	114.2 PK			1.06 V	170	73.56	40.64
4	*5180.00	105.5 AV			1.06 V	170	64.86	40.64
5	#10360.00	54.3 PK	74.0	-19.7	1.00 V	206	7.55	46.75
6	#10360.00	41.3 AV	54.0	-12.7	1.00 V	206	-5.45	46.75
7	15540.00	60.1 PK	74.0	-13.9	1.06 V	147	8.90	51.20
8	15540.00	47.2 AV	54.0	-6.8	1.06 V	147	-4.00	51.20

**REMARKS:**

1. Emission Level(dBuV/m) = Raw Value(dBuV) + Correction Factor(dB/m)
2. Correction Factor(dB/m) = Antenna Factor(dB/m) + Cable Factor(dB) – Pre-Amplifier Factor(dB)
3. The other emission levels were very low against the limit.
4. Margin value = Emission Level – Limit value
5. " \* ": Fundamental frequency.
6. " # ": The radiated frequency is out of the restricted band.



A D T

<b>CHANNEL</b>	TX Channel 40	<b>DETECTOR FUNCTION</b>	Peak (PK)
<b>FREQUENCY RANGE</b>	1GHz ~ 40GHz		Average (AV)

**ANTENNA POLARITY & TEST DISTANCE: HORIZONTAL AT 3 M**

NO.	FREQ. (MHz)	EMISSION LEVEL (dBuV/m)	LIMIT (dBuV/m)	MARGIN (dB)	ANTENNA HEIGHT (m)	TABLE ANGLE (Degree)	RAW VALUE (dBuV)	CORRECTION FACTOR (dB/m)
1	*5200.00	105.1 PK			1.01 H	152	64.42	40.68
2	*5200.00	97.8 AV			1.01 H	152	57.12	40.68
3	#10400.00	58.7 PK	74.0	-15.3	1.25 H	262	11.99	46.71
4	#10400.00	44.6 AV	54.0	-9.4	1.25 H	262	-2.11	46.71
5	15600.00	63.4 PK	74.0	-10.6	1.01 H	258	12.12	51.28
6	15600.00	49.6 AV	54.0	-4.4	1.01 H	258	-1.68	51.28

**ANTENNA POLARITY & TEST DISTANCE: VERTICAL AT 3 M**

NO.	FREQ. (MHz)	EMISSION LEVEL (dBuV/m)	LIMIT (dBuV/m)	MARGIN (dB)	ANTENNA HEIGHT (m)	TABLE ANGLE (Degree)	RAW VALUE (dBuV)	CORRECTION FACTOR (dB/m)
1	*5200.00	118.0 PK			1.04 V	179	77.32	40.68
2	*5200.00	110.3 AV			1.04 V	179	69.62	40.68
3	#10400.00	58.8 PK	74.0	-15.2	1.05 V	217	12.09	46.71
4	#10400.00	44.6 AV	54.0	-9.4	1.05 V	217	-2.11	46.71
5	15600.00	61.1 PK	74.0	-12.9	1.08 V	145	9.82	51.28
6	15600.00	49.2 AV	54.0	-4.8	1.08 V	145	-2.08	51.28

**REMARKS:**

1. Emission Level(dBuV/m) = Raw Value(dBuV) + Correction Factor(dB/m)
2. Correction Factor(dB/m) = Antenna Factor(dB/m) + Cable Factor(dB) – Pre-Amplifier Factor(dB)
3. The other emission levels were very low against the limit.
4. Margin value = Emission Level – Limit value
5. " \* ": Fundamental frequency.
6. " # ": The radiated frequency is out of the restricted band.



<b>CHANNEL</b>	TX Channel 48	<b>DETECTOR FUNCTION</b>	Peak (PK)
<b>FREQUENCY RANGE</b>	1GHz ~ 40GHz		Average (AV)

ANTENNA POLARITY & TEST DISTANCE: HORIZONTAL AT 3 M								
NO.	FREQ. (MHz)	EMISSION LEVEL (dBuV/m)	LIMIT (dBuV/m)	MARGIN (dB)	ANTENNA HEIGHT (m)	TABLE ANGLE (Degree)	RAW VALUE (dBuV)	CORRECTION FACTOR (dB/m)
1	*5240.00	104.6 PK			1.03 H	161	63.85	40.75
2	*5240.00	97.6 AV			1.03 H	161	56.85	40.75
3	5350.00	54.8 PK	74.0	-19.2	1.08 H	146	13.86	40.94
4	5350.00	34.5 AV	54.0	-19.5	1.08 H	146	-6.44	40.94
5	#10480.00	58.6 PK	74.0	-15.4	1.28 H	270	11.80	46.80
6	#10480.00	44.3 AV	54.0	-9.7	1.28 H	270	-2.50	46.80
7	15720.00	63.8 PK	74.0	-10.2	1.06 H	268	12.46	51.34
8	15720.00	50.0 AV	54.0	-4.0	1.06 H	268	-1.34	51.34

ANTENNA POLARITY & TEST DISTANCE: VERTICAL AT 3 M								
NO.	FREQ. (MHz)	EMISSION LEVEL (dBuV/m)	LIMIT (dBuV/m)	MARGIN (dB)	ANTENNA HEIGHT (m)	TABLE ANGLE (Degree)	RAW VALUE (dBuV)	CORRECTION FACTOR (dB/m)
1	*5240.00	117.7 PK			1.05 V	184	76.95	40.75
2	*5240.00	110.0 AV			1.05 V	184	69.25	40.75
3	5350.00	54.0 PK	74.0	-20.0	1.05 V	184	13.06	40.94
4	5350.00	44.0 AV	54.0	-10.0	1.05 V	184	3.06	40.94
5	#10480.00	59.1 PK	74.0	-14.9	1.10 V	226	12.30	46.80
6	#10480.00	44.7 AV	54.0	-9.3	1.10 V	226	-2.10	46.80
7	15720.00	60.8 PK	74.0	-13.2	1.13 V	157	9.46	51.34
8	15720.00	48.9 AV	54.0	-5.1	1.13 V	157	-2.44	51.34

**REMARKS:**

1. Emission Level(dBuV/m) = Raw Value(dBuV) + Correction Factor(dB/m)
2. Correction Factor(dB/m) = Antenna Factor(dB/m) + Cable Factor(dB) – Pre-Amplifier Factor(dB)
3. The other emission levels were very low against the limit.
4. Margin value = Emission Level – Limit value
5. " \* ": Fundamental frequency.
6. " # ": The radiated frequency is out of the restricted band.



A D T

<b>CHANNEL</b>	TX Channel 149	<b>DETECTOR FUNCTION</b>	Peak (PK)
<b>FREQUENCY RANGE</b>	1GHz ~ 40GHz		Average (AV)

**ANTENNA POLARITY & TEST DISTANCE: HORIZONTAL AT 3 M**

NO.	FREQ. (MHz)	EMISSION LEVEL (dBuV/m)	LIMIT (dBuV/m)	MARGIN (dB)	ANTENNA HEIGHT (m)	TABLE ANGLE (Degree)	RAW VALUE (dBuV)	CORRECTION FACTOR (dB/m)
1	#5725.00	52.4 PK	78.2	-25.8	1.03 H	143	10.92	41.48
2	*5745.00	101.3 PK			1.03 H	143	59.80	41.50
3	*5745.00	92.3 AV			1.03 H	143	50.80	41.50
4	11490.00	54.1 PK	74.0	-19.9	1.41 H	318	6.96	47.14
5	11490.00	41.7 AV	54.0	-12.3	1.41 H	318	-5.44	47.14
6	#17235.00	61.6 PK	74.0	-12.4	1.01 H	243	6.74	54.86
7	#17235.00	47.2 AV	54.0	-6.8	1.01 H	243	-7.66	54.86

**ANTENNA POLARITY & TEST DISTANCE: VERTICAL AT 3 M**

NO.	FREQ. (MHz)	EMISSION LEVEL (dBuV/m)	LIMIT (dBuV/m)	MARGIN (dB)	ANTENNA HEIGHT (m)	TABLE ANGLE (Degree)	RAW VALUE (dBuV)	CORRECTION FACTOR (dB/m)
1	#5725.00	77.0 PK	78.2	-1.2	1.17 V	180	35.52	41.48
2	*5745.00	112.8 PK			1.07 V	169	71.30	41.50
3	*5745.00	103.3 AV			1.07 V	169	61.80	41.50
4	11490.00	53.4 PK	74.0	-20.6	1.02 V	209	6.26	47.14
5	11490.00	40.9 AV	54.0	-13.1	1.02 V	209	-6.24	47.14
6	#17235.00	59.7 PK	74.0	-14.3	1.10 V	147	4.84	54.86
7	#17235.00	47.4 AV	54.0	-6.6	1.10 V	147	-7.46	54.86

**REMARKS:**

1. Emission Level(dBuV/m) = Raw Value(dBuV) + Correction Factor(dB/m)
2. Correction Factor(dB/m) = Antenna Factor(dB/m) + Cable Factor(dB) – Pre-Amplifier Factor(dB)
3. The other emission levels were very low against the limit.
4. Margin value = Emission Level – Limit value
5. " \* ": Fundamental frequency.
6. " # ": The radiated frequency is out of the restricted band.



A D T

<b>CHANNEL</b>	TX Channel 157	<b>DETECTOR FUNCTION</b>	Peak (PK)
<b>FREQUENCY RANGE</b>	1GHz ~ 40GHz		Average (AV)

**ANTENNA POLARITY & TEST DISTANCE: HORIZONTAL AT 3 M**

NO.	FREQ. (MHz)	EMISSION LEVEL (dBuV/m)	LIMIT (dBuV/m)	MARGIN (dB)	ANTENNA HEIGHT (m)	TABLE ANGLE (Degree)	RAW VALUE (dBuV)	CORRECTION FACTOR (dB/m)
1	*5785.00	104.8 PK			1.02 H	155	63.25	41.55
2	*5785.00	97.4 AV			1.02 H	155	55.85	41.55
3	11570.00	58.3 PK	74.0	-15.7	1.25 H	269	11.11	47.19
4	11570.00	44.6 AV	54.0	-9.4	1.25 H	269	-2.59	47.19
5	#17355.00	62.5 PK	74.0	-11.5	1.00 H	278	7.42	55.08
6	#17355.00	49.2 AV	54.0	-4.8	1.00 H	278	-5.88	55.08

**ANTENNA POLARITY & TEST DISTANCE: VERTICAL AT 3 M**

NO.	FREQ. (MHz)	EMISSION LEVEL (dBuV/m)	LIMIT (dBuV/m)	MARGIN (dB)	ANTENNA HEIGHT (m)	TABLE ANGLE (Degree)	RAW VALUE (dBuV)	CORRECTION FACTOR (dB/m)
1	*5785.00	118.0 PK			1.04 V	179	76.45	41.55
2	*5785.00	109.9 AV			1.04 V	179	68.35	41.55
3	11570.00	57.2 PK	74.0	-16.8	1.02 V	225	10.01	47.19
4	11570.00	43.8 AV	54.0	-10.2	1.02 V	225	-3.39	47.19
5	#17355.00	61.7 PK	74.0	-12.3	1.03 V	158	6.62	55.08
6	#17355.00	49.8 AV	54.0	-4.2	1.03 V	158	-5.28	55.08

**REMARKS:**

1. Emission Level(dBuV/m) = Raw Value(dBuV) + Correction Factor(dB/m)
2. Correction Factor(dB/m) = Antenna Factor(dB/m) + Cable Factor(dB) – Pre-Amplifier Factor(dB)
3. The other emission levels were very low against the limit.
4. Margin value = Emission Level – Limit value
5. " \* ": Fundamental frequency.
6. " # ": The radiated frequency is out of the restricted band.



A D T

<b>CHANNEL</b>	TX Channel 165	<b>DETECTOR FUNCTION</b>	Peak (PK)
<b>FREQUENCY RANGE</b>	1GHz ~ 40GHz		Average (AV)

**ANTENNA POLARITY & TEST DISTANCE: HORIZONTAL AT 3 M**

NO.	FREQ. (MHz)	EMISSION LEVEL (dBuV/m)	LIMIT (dBuV/m)	MARGIN (dB)	ANTENNA HEIGHT (m)	TABLE ANGLE (Degree)	RAW VALUE (dBuV)	CORRECTION FACTOR (dB/m)
1	*5825.00	104.7 PK			1.01 H	134	63.08	41.62
2	*5825.00	97.6 AV			1.01 H	134	55.98	41.62
3	#5850.00	51.3 PK	78.2	-26.9	1.00 H	139	9.62	41.68
4	11650.00	57.9 PK	74.0	-16.1	1.24 H	275	10.67	47.23
5	11650.00	44.4 AV	54.0	-9.6	1.24 H	275	-2.83	47.23
6	#17475.00	64.0 PK	74.0	-10.0	1.00 H	266	8.69	55.31
7	#17475.00	50.1 AV	54.0	-3.9	1.00 H	266	-5.21	55.31

**ANTENNA POLARITY & TEST DISTANCE: VERTICAL AT 3 M**

NO.	FREQ. (MHz)	EMISSION LEVEL (dBuV/m)	LIMIT (dBuV/m)	MARGIN (dB)	ANTENNA HEIGHT (m)	TABLE ANGLE (Degree)	RAW VALUE (dBuV)	CORRECTION FACTOR (dB/m)
1	*5825.00	116.4 PK			1.13 V	174	74.78	41.62
2	*5825.00	107.1 AV			1.13 V	174	65.48	41.62
3	#5850.00	77.2 PK	78.2	-1.0	1.13 V	174	35.52	41.68
4	11650.00	57.1 PK	74.0	-16.9	1.00 V	217	9.87	47.23
5	11650.00	43.4 AV	54.0	-10.6	1.00 V	217	-3.83	47.23
6	#17475.00	62.0 PK	74.0	-12.0	1.00 V	169	6.69	55.31
7	#17475.00	49.9 AV	54.0	-4.1	1.00 V	169	-5.41	55.31

**REMARKS:**

1. Emission Level(dBuV/m) = Raw Value(dBuV) + Correction Factor(dB/m)
2. Correction Factor(dB/m) = Antenna Factor(dB/m) + Cable Factor(dB) – Pre-Amplifier Factor(dB)
3. The other emission levels were very low against the limit.
4. Margin value = Emission Level – Limit value
5. " \* ": Fundamental frequency.
6. " # ": The radiated frequency is out of the restricted band.



A D T

802.11ac (VHT40)

<b>CHANNEL</b>	TX Channel 38	<b>DETECTOR FUNCTION</b>	Peak (PK)
<b>FREQUENCY RANGE</b>	1GHz ~ 40GHz		Average (AV)

**ANTENNA POLARITY & TEST DISTANCE: HORIZONTAL AT 3 M**

NO.	FREQ. (MHz)	EMISSION LEVEL (dBuV/m)	LIMIT (dBuV/m)	MARGIN (dB)	ANTENNA HEIGHT (m)	TABLE ANGLE (Degree)	RAW VALUE (dBuV)	CORRECTION FACTOR (dB/m)
1	5150.00	65.4 PK	74.0	-8.6	1.03 H	160	24.84	40.56
2	5150.00	51.2 AV	54.0	-2.8	1.03 H	160	10.64	40.56
3	*5190.00	92.7 PK			1.03 H	160	52.04	40.66
4	*5190.00	83.4 AV			1.03 H	160	42.74	40.66
5	#6920.00	54.3 PK	74.0	-19.7	1.10 H	262	10.54	43.76
6	#6920.00	46.5 AV	54.0	-7.5	1.10 H	262	2.74	43.76
7	#10380.00	44.6 PK	74.0	-29.4	1.31 H	275	-2.13	46.73
8	#10380.00	34.0 AV	54.0	-20.0	1.31 H	275	-12.73	46.73
9	15570.00	64.7 PK	74.0	-9.3	1.00 H	260	13.46	51.24
10	15570.00	40.4 AV	54.0	-13.6	1.00 H	260	-10.84	51.24

**ANTENNA POLARITY & TEST DISTANCE: VERTICAL AT 3 M**

NO.	FREQ. (MHz)	EMISSION LEVEL (dBuV/m)	LIMIT (dBuV/m)	MARGIN (dB)	ANTENNA HEIGHT (m)	TABLE ANGLE (Degree)	RAW VALUE (dBuV)	CORRECTION FACTOR (dB/m)
1	5150.00	67.6 PK	74.0	-6.4	1.08 V	168	27.04	40.56
2	5150.00	53.0 AV	54.0	-1.0	1.08 V	168	12.44	40.56
3	*5190.00	105.7 PK			1.08 V	168	65.04	40.66
4	*5190.00	96.5 AV			1.08 V	168	55.84	40.66
5	#6920.00	56.0 PK	74.0	-18.0	1.04 V	196	12.24	43.76
6	#6920.00	48.3 AV	54.0	-5.7	1.04 V	196	4.54	43.76
7	#10380.00	45.3 PK	74.0	-28.7	1.10 V	225	-1.43	46.73
8	#10380.00	33.4 AV	54.0	-20.6	1.10 V	225	-13.33	46.73
9	15570.00	65.3 PK	74.0	-8.7	1.13 V	152	14.06	51.24
10	15570.00	42.6 AV	54.0	-11.4	1.13 V	152	-8.64	51.24

**REMARKS:**

1. Emission Level(dBuV/m) = Raw Value(dBuV) + Correction Factor(dB/m)
2. Correction Factor(dB/m) = Antenna Factor(dB/m) + Cable Factor(dB) – Pre-Amplifier Factor(dB)
3. The other emission levels were very low against the limit.
4. Margin value = Emission Level – Limit value
5. " \* ": Fundamental frequency.
6. " # ": The radiated frequency is out of the restricted band.



A D T

<b>CHANNEL</b>	TX Channel 46	<b>DETECTOR FUNCTION</b>	Peak (PK)
<b>FREQUENCY RANGE</b>	1GHz ~ 40GHz		Average (AV)

**ANTENNA POLARITY & TEST DISTANCE: HORIZONTAL AT 3 M**

NO.	FREQ. (MHz)	EMISSION LEVEL (dBuV/m)	LIMIT (dBuV/m)	MARGIN (dB)	ANTENNA HEIGHT (m)	TABLE ANGLE (Degree)	RAW VALUE (dBuV)	CORRECTION FACTOR (dB/m)
1	5150.00	62.1 PK	74.0	-11.9	1.02 H	161	21.54	40.56
2	5150.00	51.4 AV	54.0	-2.6	1.02 H	161	10.84	40.56
3	*5230.00	102.4 PK			1.02 H	161	61.66	40.74
4	*5230.00	94.7 AV			1.02 H	161	53.96	40.74
5	5350.00	53.4 PK	74.0	-20.6	1.02 H	161	12.46	40.94
6	5350.00	42.3 AV	54.0	-11.7	1.02 H	161	1.36	40.94
7	#10460.00	52.1 PK	74.0	-21.9	1.46 H	295	5.33	46.77
8	#10460.00	38.4 AV	54.0	-15.6	1.46 H	295	-8.37	46.77
9	15690.00	58.6 PK	74.0	-15.4	1.04 H	256	7.30	51.30
10	15690.00	44.7 AV	54.0	-9.3	1.04 H	256	-6.60	51.30

**ANTENNA POLARITY & TEST DISTANCE: VERTICAL AT 3 M**

NO.	FREQ. (MHz)	EMISSION LEVEL (dBuV/m)	LIMIT (dBuV/m)	MARGIN (dB)	ANTENNA HEIGHT (m)	TABLE ANGLE (Degree)	RAW VALUE (dBuV)	CORRECTION FACTOR (dB/m)
1	5150.00	63.9 PK	74.0	-10.1	1.09 V	177	23.34	40.56
2	5150.00	53.1 AV	54.0	-0.9	1.09 V	177	12.54	40.56
3	*5230.00	115.3 PK			1.09 V	177	74.56	40.74
4	*5230.00	107.8 AV			1.09 V	177	67.06	40.74
5	5350.00	54.8 PK	74.0	-19.2	1.09 V	177	13.86	40.94
6	5350.00	44.1 AV	54.0	-9.9	1.09 V	177	3.16	40.94
7	#10460.00	53.4 PK	74.0	-20.6	1.10 V	226	6.63	46.77
8	#10460.00	37.9 AV	54.0	-16.1	1.10 V	226	-8.87	46.77
9	15690.00	59.3 PK	74.0	-14.7	1.14 V	154	8.00	51.30
10	15690.00	45.6 AV	54.0	-8.4	1.14 V	154	-5.70	51.30

**REMARKS:**

1. Emission Level(dBuV/m) = Raw Value(dBuV) + Correction Factor(dB/m)
2. Correction Factor(dB/m) = Antenna Factor(dB/m) + Cable Factor(dB) – Pre-Amplifier Factor(dB)
3. The other emission levels were very low against the limit.
4. Margin value = Emission Level – Limit value
5. " \* ": Fundamental frequency.
6. " # ": The radiated frequency is out of the restricted band.



A D T

<b>CHANNEL</b>	TX Channel 151	<b>DETECTOR FUNCTION</b>	Peak (PK)
<b>FREQUENCY RANGE</b>	1GHz ~ 40GHz		Average (AV)

**ANTENNA POLARITY & TEST DISTANCE: HORIZONTAL AT 3 M**

NO.	FREQ. (MHz)	EMISSION LEVEL (dBuV/m)	LIMIT (dBuV/m)	MARGIN (dB)	ANTENNA HEIGHT (m)	TABLE ANGLE (Degree)	RAW VALUE (dBuV)	CORRECTION FACTOR (dB/m)
1	#5715.00	65.6 PK	74.0	-8.4	1.02 H	149	24.14	41.46
2	#5715.00	51.4 AV	54.0	-2.6	1.02 H	149	9.94	41.46
3	#5725.00	68.3 PK	78.2	-9.9	1.02 H	149	26.82	41.48
4	*5755.00	92.7 PK			1.02 H	149	51.19	41.51
5	*5755.00	83.5 AV			1.02 H	149	41.99	41.51
6	11510.00	45.1 PK	74.0	-28.9	1.37 H	260	-2.05	47.15
7	11510.00	34.3 AV	54.0	-19.7	1.37 H	260	-12.85	47.15
8	#17265.00	64.4 PK	74.0	-9.6	1.00 H	249	9.46	54.94
9	#17265.00	40.0 AV	54.0	-14.0	1.00 H	249	-14.94	54.94

**ANTENNA POLARITY & TEST DISTANCE: VERTICAL AT 3 M**

NO.	FREQ. (MHz)	EMISSION LEVEL (dBuV/m)	LIMIT (dBuV/m)	MARGIN (dB)	ANTENNA HEIGHT (m)	TABLE ANGLE (Degree)	RAW VALUE (dBuV)	CORRECTION FACTOR (dB/m)
1	#5715.00	67.8 PK	74.0	-6.2	1.06 V	178	26.34	41.46
2	#5715.00	53.0 AV	54.0	-1.0	1.06 V	178	11.54	41.46
3	#5725.00	69.2 PK	78.2	-9.0	1.06 V	178	27.72	41.48
4	*5755.00	107.3 PK			1.08 V	168	65.79	41.51
5	*5755.00	97.2 AV			1.08 V	168	55.69	41.51
6	11510.00	45.3 PK	74.0	-28.7	1.10 V	225	-1.85	47.15
7	11510.00	33.4 AV	54.0	-20.6	1.10 V	225	-13.75	47.15
8	#17265.00	65.3 PK	74.0	-8.7	1.13 V	152	10.36	54.94
9	#17265.00	42.6 AV	54.0	-11.4	1.13 V	152	-12.34	54.94

**REMARKS:**

1. Emission Level(dBuV/m) = Raw Value(dBuV) + Correction Factor(dB/m)
2. Correction Factor(dB/m) = Antenna Factor(dB/m) + Cable Factor(dB) – Pre-Amplifier Factor(dB)
3. The other emission levels were very low against the limit.
4. Margin value = Emission Level – Limit value
5. " \* ": Fundamental frequency.
6. " # ": The radiated frequency is out of the restricted band.



A D T

<b>CHANNEL</b>	TX Channel 159	<b>DETECTOR FUNCTION</b>	Peak (PK)
<b>FREQUENCY RANGE</b>	1GHz ~ 40GHz		Average (AV)

**ANTENNA POLARITY & TEST DISTANCE: HORIZONTAL AT 3 M**

NO.	FREQ. (MHz)	EMISSION LEVEL (dBuV/m)	LIMIT (dBuV/m)	MARGIN (dB)	ANTENNA HEIGHT (m)	TABLE ANGLE (Degree)	RAW VALUE (dBuV)	CORRECTION FACTOR (dB/m)
1	*5795.00	102.1 PK			1.02 H	176	60.54	41.56
2	*5795.00	94.5 AV			1.02 H	176	52.94	41.56
3	#5850.00	55.4 PK	78.2	-22.8	1.06 H	176	13.72	41.68
4	#5860.00	56.3 PK	74.0	-17.7	1.06 H	176	14.59	41.71
5	#5860.00	43.2 AV	54.0	-10.8	1.06 H	176	1.49	41.71
6	11590.00	52.8 PK	74.0	-21.2	1.46 H	305	5.59	47.21
7	11590.00	38.9 AV	54.0	-15.1	1.46 H	305	-8.31	47.21
8	#17385.00	58.8 PK	74.0	-15.2	1.00 H	263	3.69	55.11
9	#17385.00	45.1 AV	54.0	-8.9	1.00 H	263	-10.01	55.11

**ANTENNA POLARITY & TEST DISTANCE: VERTICAL AT 3 M**

NO.	FREQ. (MHz)	EMISSION LEVEL (dBuV/m)	LIMIT (dBuV/m)	MARGIN (dB)	ANTENNA HEIGHT (m)	TABLE ANGLE (Degree)	RAW VALUE (dBuV)	CORRECTION FACTOR (dB/m)
1	*5795.00	110.8 PK			1.14 V	178	69.24	41.56
2	*5795.00	101.8 AV			1.14 V	178	60.24	41.56
3	#5850.00	57.2 PK	78.2	-21.0	1.14 V	178	15.52	41.68
4	#5860.00	57.5 PK	74.0	-16.5	1.14 V	178	15.79	41.71
5	#5860.00	44.8 AV	54.0	-9.2	1.14 V	178	3.09	41.71
6	11590.00	53.6 PK	74.0	-20.4	1.05 V	234	6.39	47.21
7	11590.00	37.8 AV	54.0	-16.2	1.05 V	234	-9.41	47.21
8	#17385.00	59.0 PK	74.0	-15.0	1.18 V	147	3.89	55.11
9	#17385.00	45.5 AV	54.0	-8.5	1.18 V	147	-9.61	55.11

**REMARKS:**

1. Emission Level(dBuV/m) = Raw Value(dBuV) + Correction Factor(dB/m)
2. Correction Factor(dB/m) = Antenna Factor(dB/m) + Cable Factor(dB) – Pre-Amplifier Factor(dB)
3. The other emission levels were very low against the limit.
4. Margin value = Emission Level – Limit value
5. " \* ": Fundamental frequency.
6. " # ": The radiated frequency is out of the restricted band.





802.11ac (VHT80)

<b>CHANNEL</b>	TX Channel 42	<b>DETECTOR FUNCTION</b>	Peak (PK)
<b>FREQUENCY RANGE</b>	1GHz ~ 40GHz		Average (AV)

**ANTENNA POLARITY & TEST DISTANCE: HORIZONTAL AT 3 M**

NO.	FREQ. (MHz)	EMISSION LEVEL (dBuV/m)	LIMIT (dBuV/m)	MARGIN (dB)	ANTENNA HEIGHT (m)	TABLE ANGLE (Degree)	RAW VALUE (dBuV)	CORRECTION FACTOR (dB/m)
1	5150.00	64.8 PK	74.0	-9.2	1.08 H	176	24.24	40.56
2	5150.00	50.8 AV	54.0	-3.2	1.08 H	176	10.24	40.56
3	*5210.00	90.2 PK			1.02 H	149	49.50	40.70
4	*5210.00	80.2 AV			1.02 H	149	39.50	40.70
5	5350.00	52.4 PK	74.0	-21.6	1.06 H	250	11.46	40.94
6	5350.00	39.4 AV	54.0	-14.6	1.06 H	250	-1.54	40.94
7	#10420.00	45.2 PK	74.0	-28.8	1.32 H	290	-1.53	46.73
8	#10420.00	34.3 AV	54.0	-19.7	1.32 H	290	-12.43	46.73
9	15630.00	64.9 PK	74.0	-9.1	1.01 H	261	13.61	51.29
10	15630.00	40.5 AV	54.0	-13.5	1.01 H	261	-10.79	51.29

**ANTENNA POLARITY & TEST DISTANCE: VERTICAL AT 3 M**

NO.	FREQ. (MHz)	EMISSION LEVEL (dBuV/m)	LIMIT (dBuV/m)	MARGIN (dB)	ANTENNA HEIGHT (m)	TABLE ANGLE (Degree)	RAW VALUE (dBuV)	CORRECTION FACTOR (dB/m)
1	5150.00	65.2 PK	74.0	-8.8	1.06 V	165	24.64	40.56
2	5150.00	52.6 AV	54.0	-1.4	1.06 V	165	12.04	40.56
3	*5210.00	102.3 PK			1.06 V	165	61.60	40.70
4	*5210.00	92.1 AV			1.06 V	165	51.40	40.70
5	5350.00	53.2 PK	74.0	-20.8	1.06 V	165	12.26	40.94
6	5350.00	40.2 AV	54.0	-13.8	1.06 V	165	-0.74	40.94
7	#10420.00	45.0 PK	74.0	-29.0	1.08 V	230	-1.73	46.73
8	#10420.00	33.1 AV	54.0	-20.9	1.08 V	230	-13.63	46.73
9	15630.00	65.2 PK	74.0	-8.8	1.12 V	162	13.91	51.29
10	15630.00	42.6 AV	54.0	-11.4	1.12 V	162	-8.69	51.29

**REMARKS:**

1. Emission Level(dBuV/m) = Raw Value(dBuV) + Correction Factor(dB/m)
2. Correction Factor(dB/m) = Antenna Factor(dB/m) + Cable Factor(dB) – Pre-Amplifier Factor(dB)
3. The other emission levels were very low against the limit.
4. Margin value = Emission Level – Limit value
5. " \* ": Fundamental frequency.
6. " # ": The radiated frequency is out of the restricted band.



A D T

<b>CHANNEL</b>	TX Channel 155	<b>DETECTOR FUNCTION</b>	Peak (PK)
<b>FREQUENCY RANGE</b>	1GHz ~ 40GHz		Average (AV)

**ANTENNA POLARITY & TEST DISTANCE: HORIZONTAL AT 3 M**

NO.	FREQ. (MHz)	EMISSION LEVEL (dBuV/m)	LIMIT (dBuV/m)	MARGIN (dB)	ANTENNA HEIGHT (m)	TABLE ANGLE (Degree)	RAW VALUE (dBuV)	CORRECTION FACTOR (dB/m)
1	#5715.00	64.4 PK	74.0	-9.6	1.00 H	134	22.94	41.46
2	#5715.00	50.7 AV	54.0	-3.3	1.00 H	134	9.24	41.46
3	#5725.00	68.4 PK	78.2	-9.8	1.00 H	134	26.92	41.48
4	*5775.00	90.3 PK			1.00 H	134	48.77	41.53
5	*5775.00	80.4 AV			1.00 H	134	38.87	41.53
6	#5850.00	54.3 PK	78.2	-23.9	1.00 H	134	12.62	41.68
7	#5860.00	52.2 PK	74.0	-21.8	1.00 H	134	10.49	41.71
8	#5860.00	39.0 AV	54.0	-15.0	1.00 H	134	-2.71	41.71
9	11550.00	45.4 PK	74.0	-28.6	1.35 H	283	-1.78	47.18
10	11550.00	34.6 AV	54.0	-19.4	1.35 H	283	-12.58	47.18
11	#17325.00	64.9 PK	74.0	-9.1	1.00 H	262	9.84	55.06
12	#17325.00	40.4 AV	54.0	-13.6	1.00 H	262	-14.66	55.06

**ANTENNA POLARITY & TEST DISTANCE: VERTICAL AT 3 M**

NO.	FREQ. (MHz)	EMISSION LEVEL (dBuV/m)	LIMIT (dBuV/m)	MARGIN (dB)	ANTENNA HEIGHT (m)	TABLE ANGLE (Degree)	RAW VALUE (dBuV)	CORRECTION FACTOR (dB/m)
1	#5715.00	68.1 PK	74.0	-5.9	1.05 V	207	26.64	41.46
2	#5715.00	52.7 AV	54.0	-1.3	1.05 V	207	11.24	41.46
3	#5725.00	70.2 PK	78.2	-8.0	1.05 V	207	28.72	41.48
4	*5775.00	100.4 PK			1.16 V	191	58.87	41.53
5	*5775.00	91.4 AV			1.16 V	191	49.87	41.53
6	#5850.00	56.9 PK	78.2	-21.3	1.05 V	207	15.22	41.68
7	#5860.00	55.1 PK	74.0	-18.9	1.05 V	207	13.39	41.71
8	#5860.00	42.0 AV	54.0	-12.0	1.05 V	207	0.29	41.71
9	11550.00	45.0 PK	74.0	-29.0	1.06 V	239	-2.18	47.18
10	11550.00	33.1 AV	54.0	-20.9	1.06 V	239	-14.08	47.18
11	#17325.00	64.9 PK	74.0	-9.1	1.17 V	148	9.84	55.06
12	#17325.00	42.2 AV	54.0	-11.8	1.17 V	148	-12.86	55.06

**REMARKS:**

1. Emission Level(dBuV/m) = Raw Value(dBuV) + Correction Factor(dB/m)
2. Correction Factor(dB/m) = Antenna Factor(dB/m) + Cable Factor(dB) – Pre-Amplifier Factor(dB)
3. The other emission levels were very low against the limit.
4. Margin value = Emission Level – Limit value
5. " \* ": Fundamental frequency.
6. " # ": The radiated frequency is out of the restricted band.

### 4.3 TRANSMIT POWER MEASUREMENT

#### 4.3.1 LIMITS OF TRANSMIT POWER MEASUREMENT

Operation Band	EUT Category		LIMIT
U-NII-1		Outdoor Access Point	1 Watt (30 dBm) (Max. e.i.r.p $\leq$ 125mW(21 dBm) at any elevation angle above 30 degrees as measured from the horizon)
		Fixed point-to-point Access Point	1 Watt (30 dBm)
	√	Indoor Access Point	1 Watt (30 dBm)
		Mobile and Portable client device	250mW (24 dBm)
U-NII-2A	---		250mW (24 dBm) or 11 dBm+10 log B*
U-NII-2C	---		250mW (24 dBm) or 11 dBm+10 log B*
U-NII-3	---		1 Watt (30 dBm)

**Note:** Where B is the 26dB emission bandwidth in MHz.

Per KDB 662911 D01 Multiple Transmitter Output Method of conducted output power measurement on IEEE 802.11 devices,

Array Gain = 0 dB (i.e., no array gain) for NANT  $\leq$  4;

Array Gain = 0 dB (i.e., no array gain) for channel widths  $\geq$  40 MHz for any NANT;

Array Gain = 5 log(NANT/NSS) dB or 3 dB, whichever is less for 20-MHz channel widths with NANT  $\geq$  5.

For power measurements on all other devices: Array Gain = 10 log(NANT/NSS) dB.



A D T

### 4.3.2 TEST INSTRUMENTS

#### FOR POWER OUTPUT MEASUREMENT

DESCRIPTION & MANUFACTURER	MODEL NO.	SERIAL NO.	CALIBRATED DATE	CALIBRATED UNTIL
Power meter Anritsu	ML2495A	1014008	Apr. 30, 2014	Apr. 29, 2015
Power sensor Anritsu	MA2411B	0917122	Apr. 30, 2014	Apr. 29, 2015

**Note:**

1. The calibration interval of the above test instruments is 12 months and the calibrations are traceable to NML/ROC and NIST/USA.
2. Tested date : Aug. 04, 2014

#### FOR 26dB OCCUPIED BANDWIDTH

DESCRIPTION & MANUFACTURER	MODEL NO.	SERIAL NO.	CALIBRATED DATE	CALIBRATED UNTIL
SPECTRUM ANALYZER R&S	FSV 40	100964	July 05, 2014	July 04, 2015

**Note:**

1. The calibration interval of the above test instruments is 12 months and the calibrations are traceable to NML/ROC and NIST/USA.
2. Tested date : Aug. 04, 2014

### 4.3.3 TEST PROCEDURE

#### FOR POWER OUTPUT MEASUREMENT

Method PM is used to perform output power measurement, trigger and gating function of wide band power meter is enabled to measure max output power of TX on burst. Duty factor is not added to measured value.

#### FOR 26dB OCCUPIED BANDWIDTH

1. Set RBW = approximately 1% of the emission bandwidth.
2. Set the VBW > RBW.
3. Detector = Peak.
4. Trace mode = max hold.
5. Measure the maximum width of the emission that is 26 dB down from the peak of the emission. Compare this with the RBW setting of the analyzer. Readjust RBW and repeat measurement as needed until the RBW/EBW ratio is approximately 1%.

### 4.3.4 DEVIATION FROM TEST STANDARD

No deviation

### 4.3.5 TEST SETUP

#### FOR POWER OUTPUT MEASUREMENT

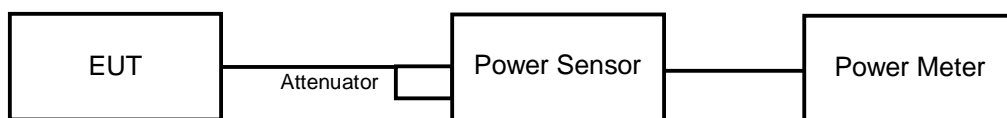

#### FOR 26dB OCCUPIED BANDWIDTH



### 4.3.6 EUT OPERATING CONDITIONS

The software provided by client to enable the EUT under transmission condition continuously at specific channel frequencies individually.



A D T

### 4.3.7 TEST RESULTS

1TX  
802.11a

CHANNEL	CHANNEL FREQUENCY (MHz)	AVERAGE POWER (mW)	AVERAGE POWER (dBm)	POWER LIMIT (dBm)	PASS/FAIL
36	5180	20.464	13.11	28.7	PASS
40	5200	33.189	15.21	28.7	PASS
48	5240	29.992	14.77	28.7	PASS
149	5745	16.904	12.28	28.7	PASS
157	5785	41.305	16.16	28.7	PASS
165	5825	43.551	16.39	28.7	PASS

Note: The directional gain is 7.3dBi > 6dBi, therefore the limit needs to reduce, so the power limit shall be reduced to "Determined Conducted Limit-(7.3-6)".

#### 26dB OCCUPIED BANDWIDTH:

CHANNEL	CHANNEL FREQUENCY (MHz)	26dBc BANDWIDTH (MHz)
36	5180	21.98
40	5200	21.93
48	5240	23.54



A D T

### SPECTRUM PLOT OF WORST VALUE

802.11a: CH40

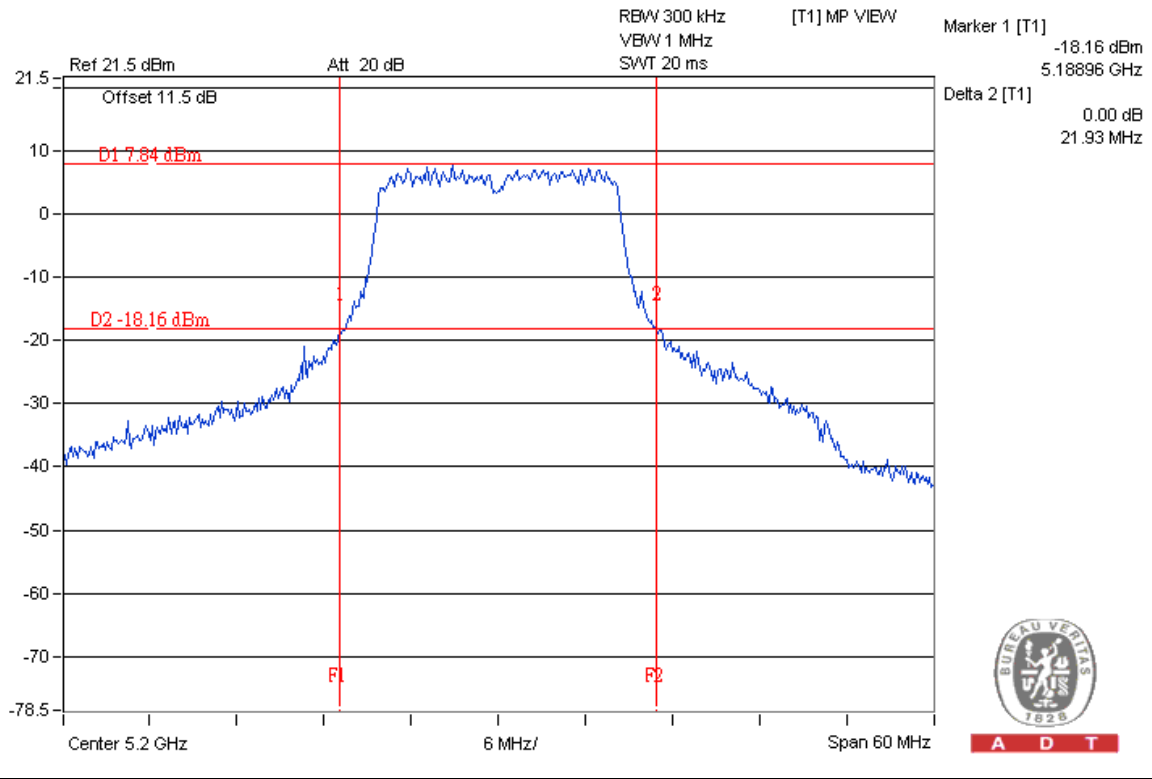



A D T

### 802.11n (HT20)

CHANNEL	CHANNEL FREQUENCY (MHz)	AVERAGE POWER (mW)	AVERAGE POWER (dBm)	POWER LIMIT (dBm)	PASS/FAIL
36	5180	14.859	11.72	28.7	PASS
40	5200	30.549	14.85	28.7	PASS
48	5240	29.444	14.69	28.7	PASS
149	5745	16.672	12.22	28.7	PASS
157	5785	41.21	16.15	28.7	PASS
165	5825	42.073	16.24	28.7	PASS

Note: The directional gain is 7.3dBi > 6dBi, therefore the limit needs to reduce, so the power limit shall be reduced to "Determined Conducted Limit-(7.3-6)".

### 26dB OCCUPIED BANDWIDTH:

CHANNEL	CHANNEL FREQUENCY (MHz)	26dBc BANDWIDTH (MHz)
36	5180	22.80
40	5200	23.56
48	5240	23.12





A D T

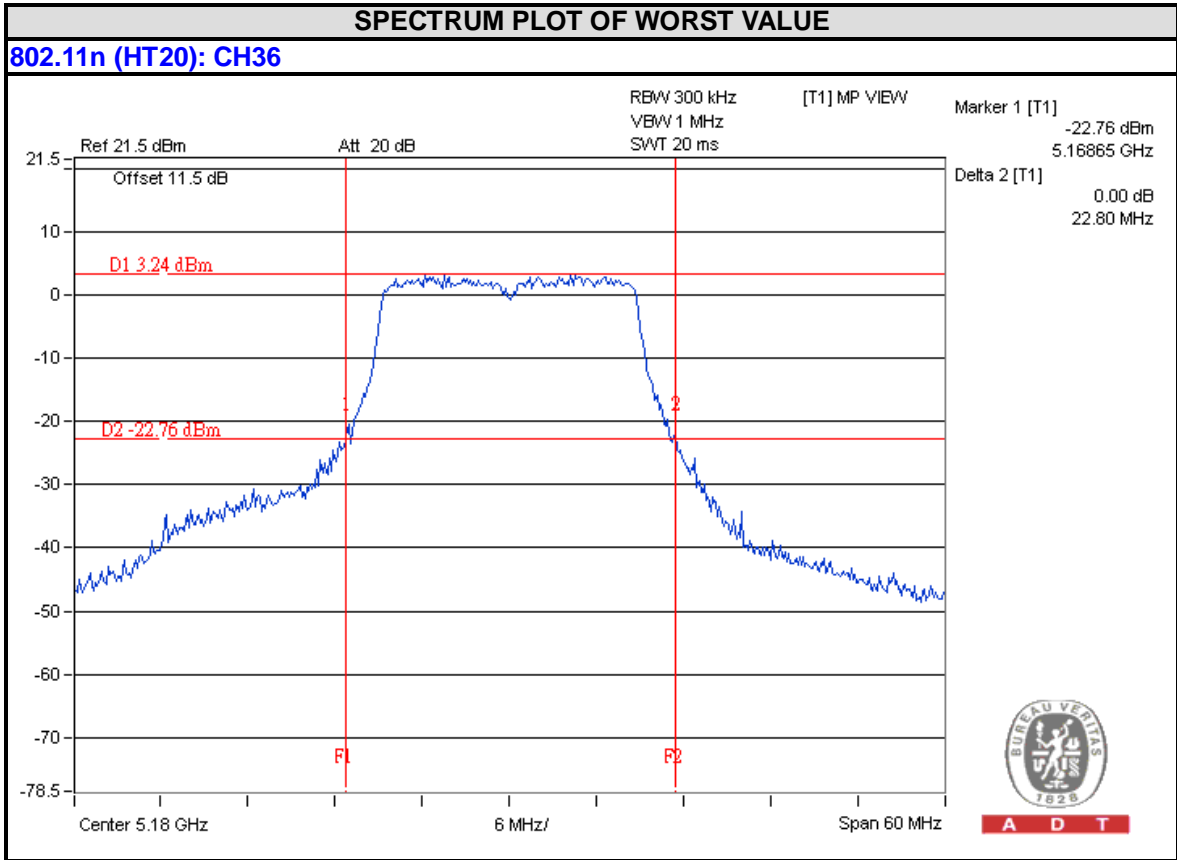



A D T

802.11n (HT40)

CHANNEL	CHANNEL FREQUENCY (MHz)	AVERAGE POWER (mW)	AVERAGE POWER (dBm)	POWER LIMIT (dBm)	PASS/FAIL
38	5190	4.285	6.32	28.7	PASS
46	5230	26.485	14.23	28.7	PASS
151	5755	5.07	7.05	28.7	PASS
159	5795	28.973	14.62	28.7	PASS

Note: The directional gain is 7.3dBi > 6dBi, therefore the limit needs to reduce, so the power limit shall be reduced to "Determined Conducted Limit-(7.3-6)".

26dB OCCUPIED BANDWIDTH:

CHANNEL	CHANNEL FREQUENCY (MHz)	26dBc BANDWIDTH (MHz)
38	5190	46.54
46	5230	47.78

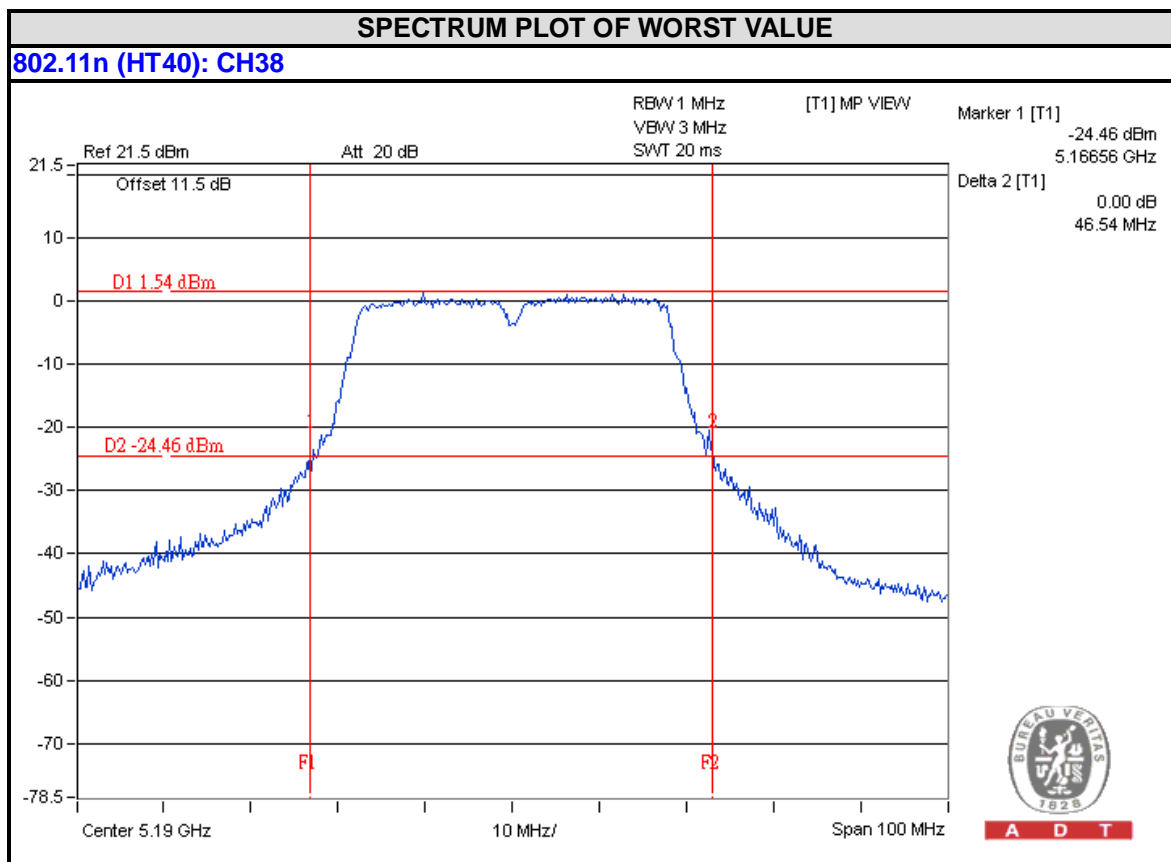



A D T

**802.11ac (VHT20)**

CHANNEL	CHANNEL FREQUENCY (MHz)	AVERAGE POWER (mW)	AVERAGE POWER (dBm)	POWER LIMIT (dBm)	PASS/FAIL
36	5180	15.524	11.91	28.7	PASS
40	5200	31.915	15.04	28.7	PASS
48	5240	29.923	14.76	28.7	PASS
149	5745	16.788	12.25	28.7	PASS
157	5785	41.4	16.17	28.7	PASS
165	5825	42.756	16.31	28.7	PASS

Note: The directional gain is 7.3dBi > 6dBi, therefore the limit needs to reduce, so the power limit shall be reduced to "Determined Conducted Limit-(7.3-6)".

**26dB OCCUPIED BANDWIDTH:**

CHANNEL	CHANNEL FREQUENCY (MHz)	26dBc BANDWIDTH (MHz)
36	5180	22.80
40	5200	23.56
48	5240	23.12



A D T

### SPECTRUM PLOT OF WORST VALUE

802.11ac (VHT20): CH36

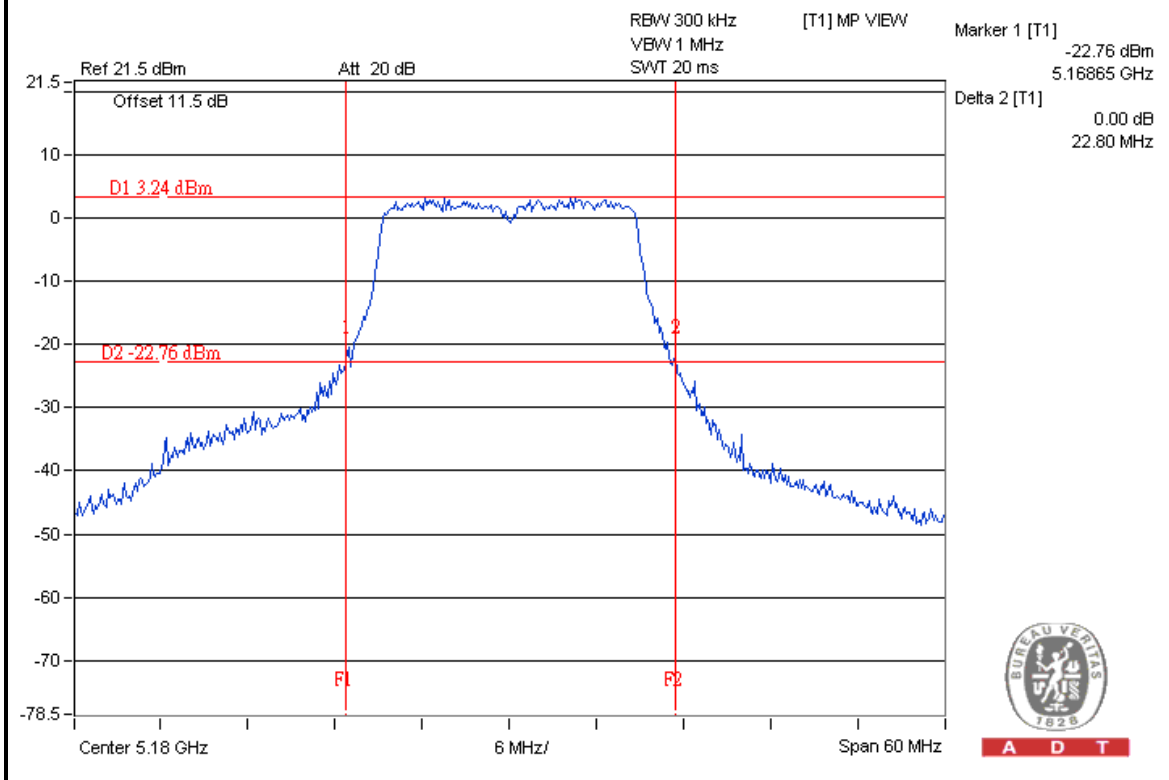



A D T

802.11ac (VHT40)

CHANNEL	CHANNEL FREQUENCY (MHz)	AVERAGE POWER (mW)	AVERAGE POWER (dBm)	POWER LIMIT (dBm)	PASS/FAIL
38	5190	4.385	6.42	28.7	PASS
46	5230	27.733	14.43	28.7	PASS
151	5755	5.248	7.20	28.7	PASS
159	5795	29.512	14.70	28.7	PASS

Note: The directional gain is 7.3dBi > 6dBi, therefore the limit needs to reduce, so the power limit shall be reduced to "Determined Conducted Limit-(7.3-6)".

26dB OCCUPIED BANDWIDTH:

CHANNEL	CHANNEL FREQUENCY (MHz)	26dBc BANDWIDTH (MHz)
38	5190	46.54
46	5230	47.78

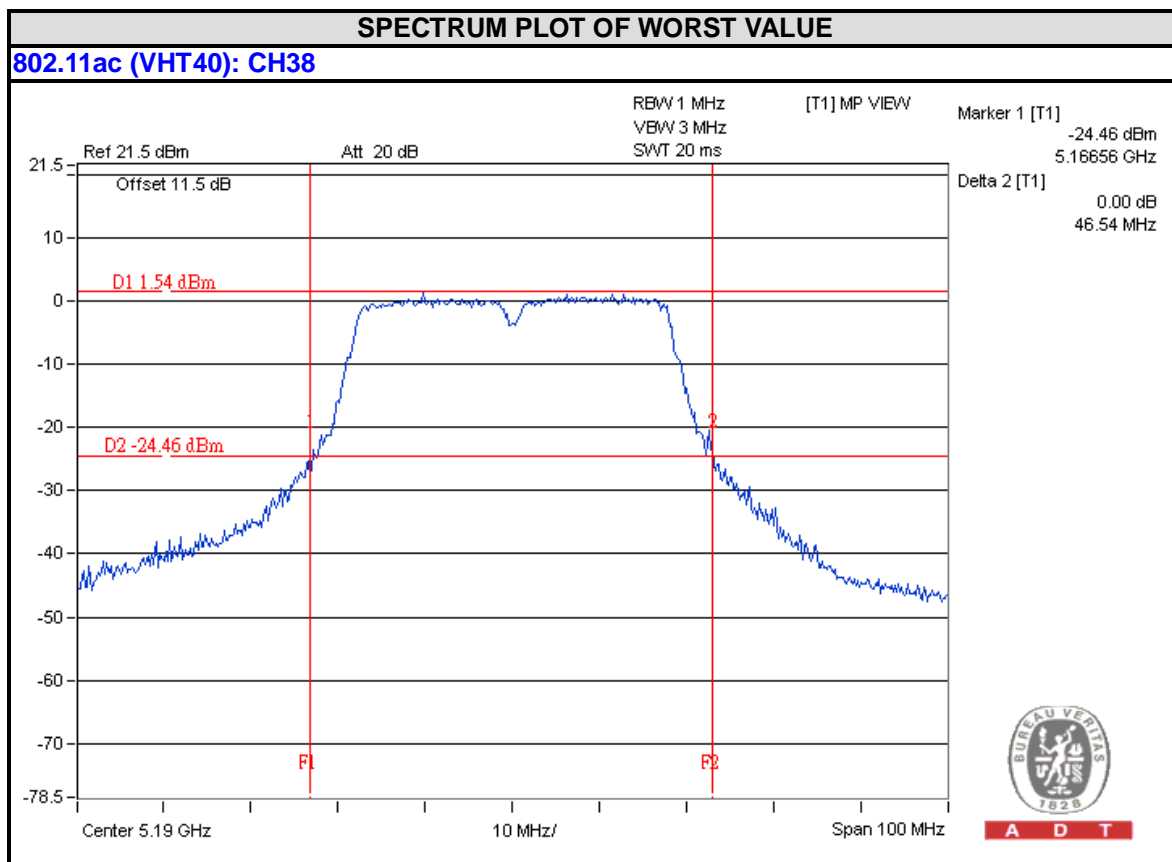



A D T

### 802.11ac (VHT80)

CHANNEL	CHANNEL FREQUENCY (MHz)	AVERAGE POWER (mW)	AVERAGE POWER (dBm)	POWER LIMIT (dBm)	PASS/FAIL
42	5210	2.917	4.65	28.7	PASS
155	5775	3.148	4.98	28.7	PASS

Note: The directional gain is 7.3dBi > 6dBi, therefore the limit needs to reduce, so the power limit shall be reduced to "Determined Conducted Limit-(7.3-6)".

### 26dB OCCUPIED BANDWIDTH:

CHANNEL	CHANNEL FREQUENCY (MHz)	26dBc BANDWIDTH (MHz)
42	5210	89.76

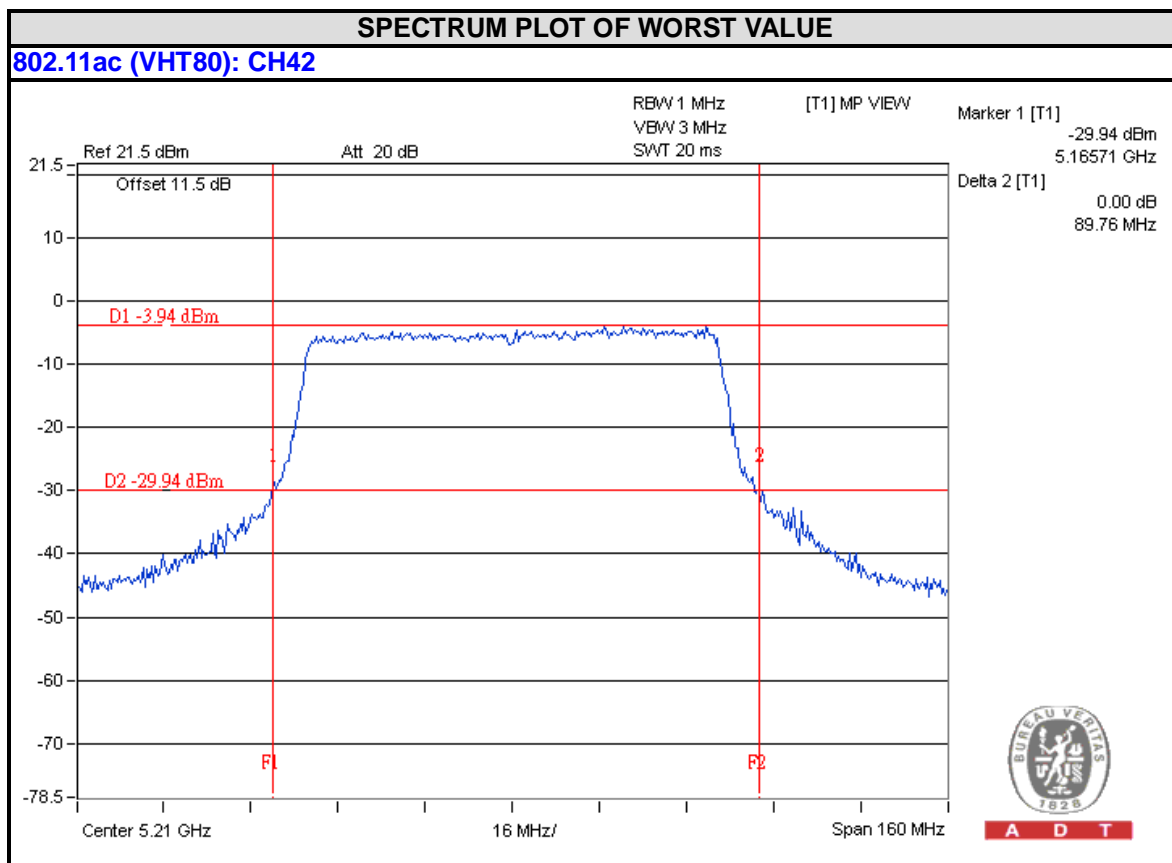



※Add test for each data rate output power (require by manufacturer):

802.11a

CHANNEL	FREQUENCY (MHz)	AVERAGE POWER (dBm)							
		Data rate							
		6Mbps	9Mbps	12Mbps	18Mbps	24Mbps	36Mbps	48Mbps	54Mbps
36	5180	13.11	13.00	13.03	13.09	12.99	13.05	12.99	13.05
40	5200	15.21	15.10	15.20	15.13	15.13	15.02	15.13	15.12
48	5240	14.77	14.72	14.74	14.59	14.75	14.69	14.72	14.58
149	5745	12.28	12.11	12.10	12.17	12.12	12.19	12.16	12.11
157	5785	16.16	16.13	16.04	16.02	16.04	15.97	16.12	16.09
165	5825	16.39	16.38	16.23	16.25	16.27	16.26	16.36	16.22

802.11n (HT20)

CHANNEL	FREQUENCY (MHz)	AVERAGE POWER (dBm)							
		Data rate							
		MCS0	MCS1	MCS2	MCS3	MCS4	MCS5	MCS6	MCS7
36	5180	11.72	11.62	11.69	11.60	11.59	11.54	11.60	11.65
44	5220	14.85	14.75	14.71	14.69	14.71	14.75	14.69	14.75
48	5240	14.69	14.51	14.56	14.63	14.52	14.52	14.67	14.59
149	5745	12.22	12.09	12.09	12.07	12.03	12.15	12.07	12.13
157	5785	16.15	16.00	16.00	16.13	16.03	15.98	16.12	16.1
165	5825	16.24	16.05	16.20	16.12	16.07	16.06	16.07	16.18

802.11n (HT40)

CHANNEL	FREQUENCY (MHz)	AVERAGE POWER (dBm)							
		Data rate							
		MCS0	MCS1	MCS2	MCS3	MCS4	MCS5	MCS6	MCS7
38	5190	6.32	6.21	6.16	6.15	6.30	6.14	6.22	6.18
46	5230	14.23	14.21	14.08	14.22	14.12	14.1	14.14	14.1
151	5755	7.05	6.94	6.95	6.96	6.95	7.02	6.95	6.98
159	5795	14.62	14.51	14.54	14.42	14.44	14.45	14.44	14.58



A D T

### 802.11ac (VHT20)

CHANNEL	FREQUENCY (MHz)	AVERAGE POWER (dBm)								
		Data rate								
		MCS0	MCS1	MCS2	MCS3	MCS4	MCS5	MCS6	MCS7	MCS8
36	5180	11.91	11.89	11.77	11.75	11.80	11.73	11.74	11.84	11.88
44	5220	15.04	14.92	14.89	14.97	15.03	15.02	14.99	14.88	14.95
48	5240	14.76	14.58	14.65	14.62	14.72	14.67	14.72	14.7	14.61
149	5745	12.25	12.09	12.08	12.23	12.21	12.06	12.19	12.12	12.18
157	5785	16.17	16.13	16.07	15.98	16.07	16.06	16.09	16.09	16.01
165	5825	16.31	16.13	16.19	16.18	16.17	16.23	16.3	16.22	16.29

### 802.11ac (VHT40)

CHANNEL	FREQUENCY (MHz)	AVERAGE POWER (dBm)									
		Data rate									
		MCS0	MCS1	MCS2	MCS3	MCS4	MCS5	MCS6	MCS7	MCS8	MCS9
38	5190	6.42	6.40	6.30	6.34	6.41	6.34	6.29	6.32	6.25	6.38
46	5230	14.43	14.26	14.24	14.28	14.26	14.3	14.27	14.3	14.32	14.35
151	5755	7.20	7.15	7.16	7.15	7.07	7.08	7.05	7.09	7.14	7.10
159	5795	14.70	14.66	14.61	14.59	14.5	14.56	14.69	14.52	14.57	14.55

### 802.11ac (VHT80)

CHANNEL	FREQUENCY (MHz)	AVERAGE POWER (dBm)									
		Data rate									
		MCS0	MCS1	MCS2	MCS3	MCS4	MCS5	MCS6	MCS7	MCS8	MCS9
42	5210	4.65	4.60	4.64	4.56	4.55	4.50	4.62	4.53	4.64	4.61
155	5775	4.98	4.94	4.86	4.89	4.91	4.79	4.92	4.84	4.96	4.93





A D T

## 2TX

### 802.11a

CHAN.	CHAN. FREQ. (MHz)	AVERAGE POWER (dBm)		TOTAL POWER (mW)	TOTAL POWER (dBm)	POWER LIMIT (dBm)	PASS / FAIL
		CHAIN 0	CHAIN 1				
36	5180	13.78	13.11	44.342	16.47	28.7	PASS
40	5200	15.03	15.21	65.031	18.13	28.7	PASS
48	5240	14.95	14.77	61.253	17.87	28.7	PASS
149	5745	12.06	12.28	32.973	15.18	28.7	PASS
157	5785	15.09	16.16	73.59	18.67	28.7	PASS
165	5825	15.36	16.39	77.907	18.92	28.7	PASS

Note: The directional gain is 7.3dBi > 6dBi, therefore the limit needs to reduce, so the power limit shall be reduced to "Determined Conducted Limit-(7.3-6)".

### 26dB OCCUPIED BANDWIDTH:

CHANNEL	CHANNEL FREQUENCY (MHz)	26dBc BANDWIDTH (MHz)	
		CHAIN 0	CHAIN 1
36	5180	22.47	21.98
40	5200	23.07	21.93
48	5240	24.17	23.54



A D T

### SPECTRUM PLOT OF WORST VALUE

802.11a / Chain(1) : CH40

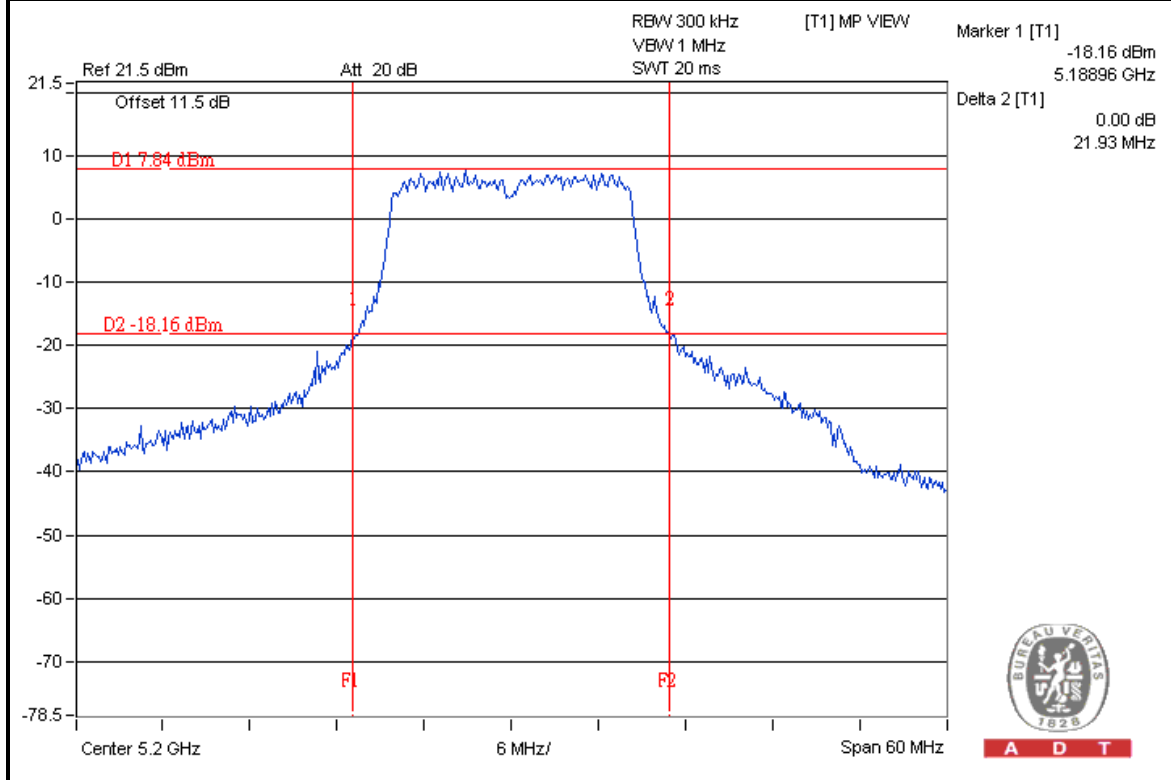

A D T



A D T

### 802.11n (HT20)

CHAN.	CHAN. FREQ. (MHz)	AVERAGE POWER (dBm)		TOTAL POWER (mW)	TOTAL POWER (dBm)	POWER LIMIT (dBm)	PASS / FAIL
		CHAIN 0	CHAIN 1				
36	5180	11.71	11.72	29.684	14.73	28.7	PASS
40	5200	14.90	14.85	61.452	17.89	28.7	PASS
48	5240	14.80	14.69	59.644	17.76	28.7	PASS
149	5745	11.91	12.22	32.196	15.08	28.7	PASS
157	5785	15.56	16.15	77.185	18.88	28.7	PASS
165	5825	15.72	16.24	79.398	19.00	28.7	PASS

Note: The directional gain is 7.3dBi > 6dBi, therefore the limit needs to reduce, so the power limit shall be reduced to "Determined Conducted Limit-(7.3-6)".

### 26dB OCCUPIED BANDWIDTH:

CHANNEL	CHANNEL FREQUENCY (MHz)	26dBc BANDWIDTH (MHz)	
		CHAIN 0	CHAIN 1
36	5180	22.55	22.80
40	5200	23.16	23.56
48	5240	23.63	23.12



A D T

### SPECTRUM PLOT OF WORST VALUE

802.11n (HT20) / Chain(0) : CH36

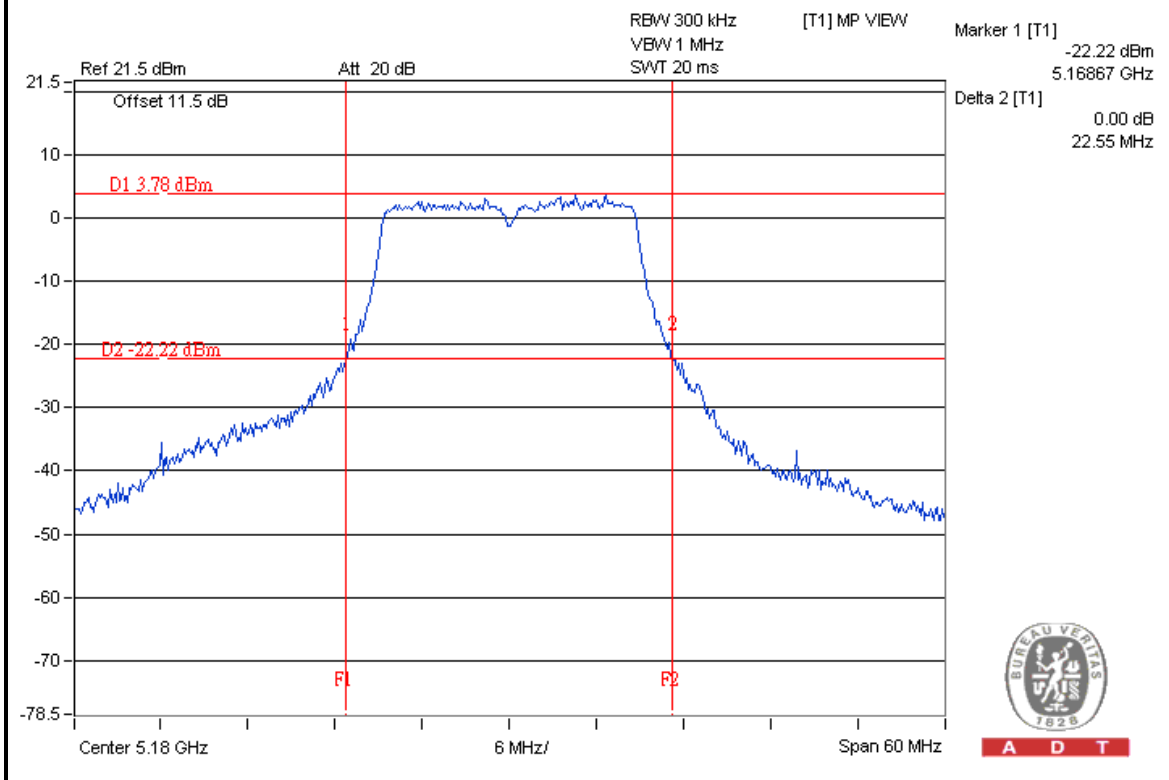

A D T



A D T

### 802.11n (HT40)

CHAN.	CHAN. FREQ. (MHz)	AVERAGE POWER (dBm)		TOTAL POWER (mW)	TOTAL POWER (dBm)	POWER LIMIT (dBm)	PASS / FAIL
		CHAIN 0	CHAIN 1				
38	5190	6.24	6.32	8.492	9.29	28.7	PASS
46	5230	14.51	14.23	54.734	17.38	28.7	PASS
151	5755	7.21	7.05	10.33	10.14	28.7	PASS
159	5795	14.41	14.62	56.579	17.53	28.7	PASS

Note: The directional gain is 7.3dBi > 6dBi, therefore the limit needs to reduce, so the power limit shall be reduced to "Determined Conducted Limit-(7.3-6)".

### 26dB OCCUPIED BANDWIDTH:

CHANNEL	CHANNEL FREQUENCY (MHz)	26dBc BANDWIDTH (MHz)	
		CHAIN 0	CHAIN 1
38	5190	47.28	46.54
46	5230	47.04	47.78

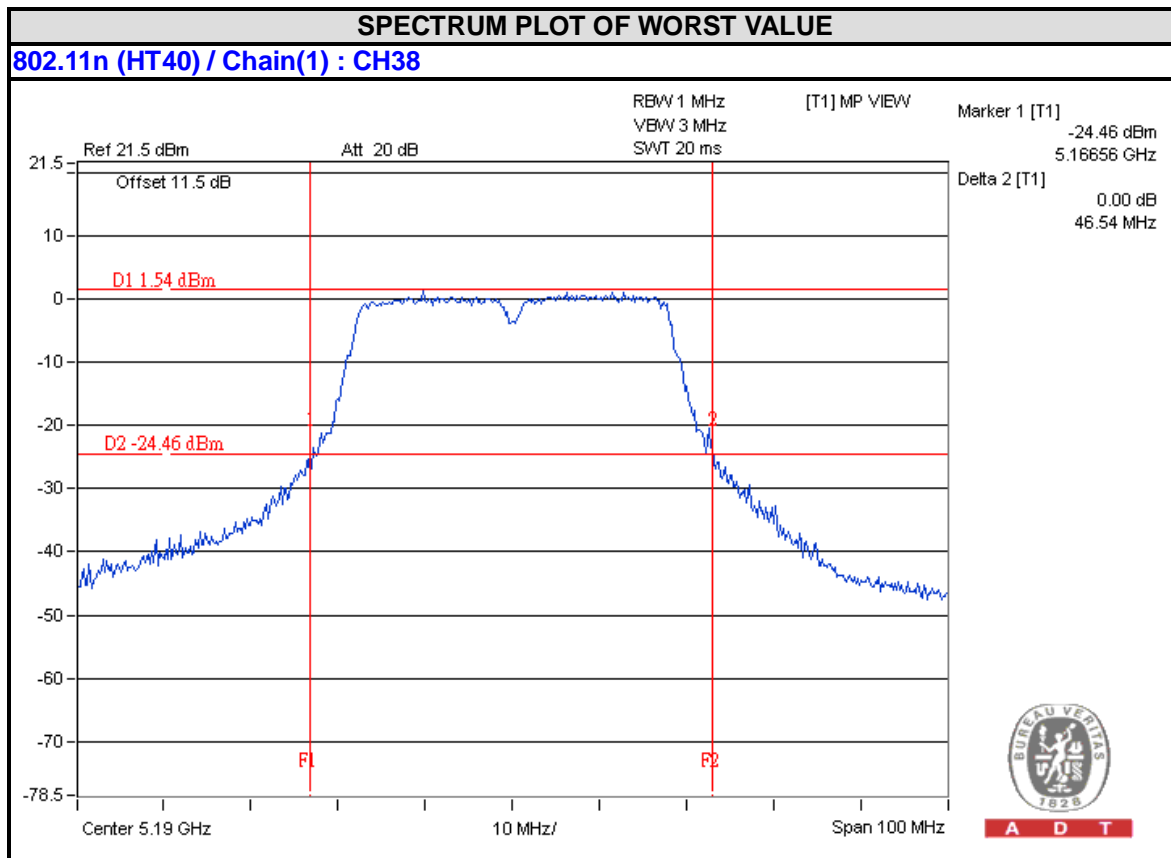



A D T

**802.11ac (VHT20)**

CHAN.	CHAN. FREQ. (MHz)	AVERAGE POWER (dBm)		TOTAL POWER (mW)	TOTAL POWER (dBm)	POWER LIMIT (dBm)	PASS / FAIL
		CHAIN 0	CHAIN 1				
36	5180	11.79	11.91	30.625	14.86	28.7	PASS
40	5200	15.01	15.04	63.611	18.04	28.7	PASS
48	5240	14.85	14.76	60.472	17.82	28.7	PASS
149	5745	12.02	12.25	32.71	15.15	28.7	PASS
157	5785	15.65	16.17	78.128	18.93	28.7	PASS
165	5825	15.77	16.31	80.513	19.06	28.7	PASS

Note: The directional gain is 7.3dBi > 6dBi, therefore the limit needs to reduce, so the power limit shall be reduced to "Determined Conducted Limit-(7.3-6)".

**26dB OCCUPIED BANDWIDTH:**

CHANNEL	CHANNEL FREQUENCY (MHz)	26dBc BANDWIDTH (MHz)	
		CHAIN 0	CHAIN 1
36	5180	22.55	22.80
40	5200	23.16	23.56
48	5240	23.63	23.12



A D T

### SPECTRUM PLOT OF WORST VALUE

802.11ac (VHT20) / Chain(0) : CH36

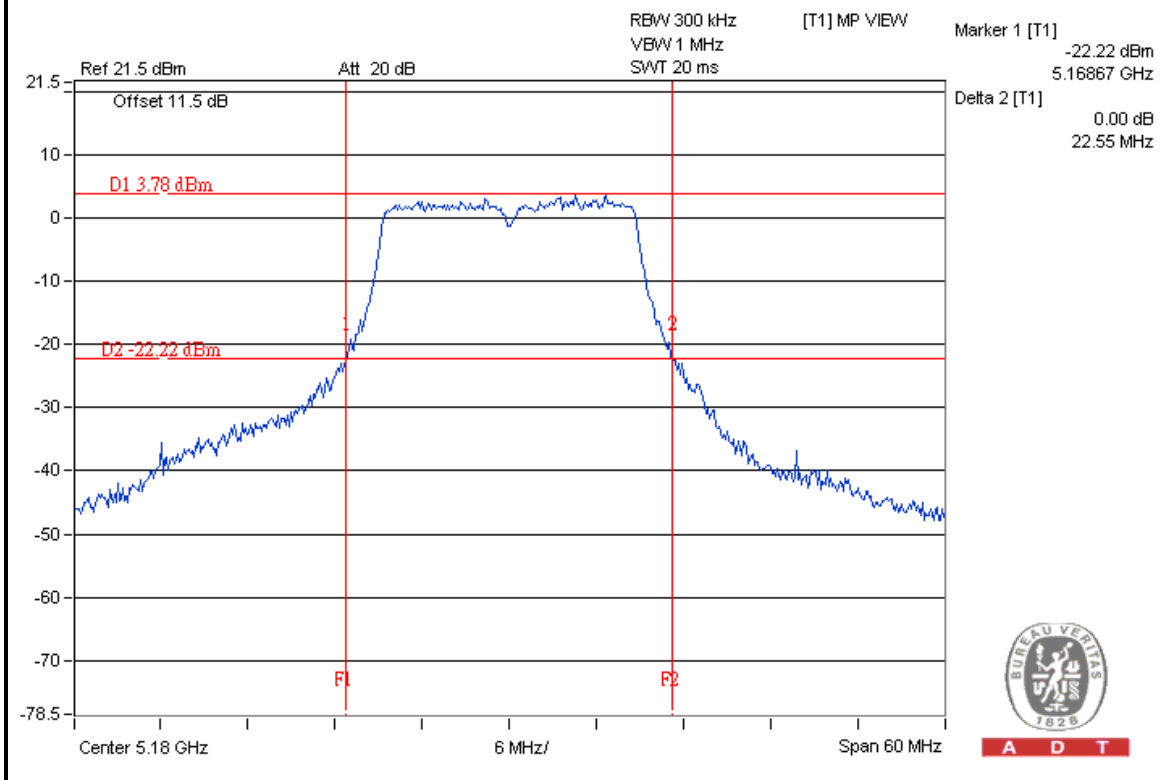

**802.11ac (VHT40)**

CHAN.	CHAN. FREQ. (MHz)	AVERAGE POWER (dBm)		TOTAL POWER (mW)	TOTAL POWER (dBm)	POWER LIMIT (dBm)	PASS / FAIL
		CHAIN 0	CHAIN 1				
38	5190	6.31	6.42	8.661	9.38	28.7	PASS
46	5230	14.54	14.43	56.178	17.50	28.7	PASS
151	5755	7.33	7.20	10.656	10.28	28.7	PASS
159	5795	14.45	14.70	57.373	17.59	28.7	PASS

Note: The directional gain is 7.3dBi > 6dBi, therefore the limit needs to reduce, so the power limit shall be reduced to "Determined Conducted Limit-(7.3-6)".

**26dB OCCUPIED BANDWIDTH:**

CHANNEL	CHANNEL FREQUENCY (MHz)	26dBc BANDWIDTH (MHz)	
		CHAIN 0	CHAIN 1
38	5190	47.28	46.54
46	5230	47.04	47.78

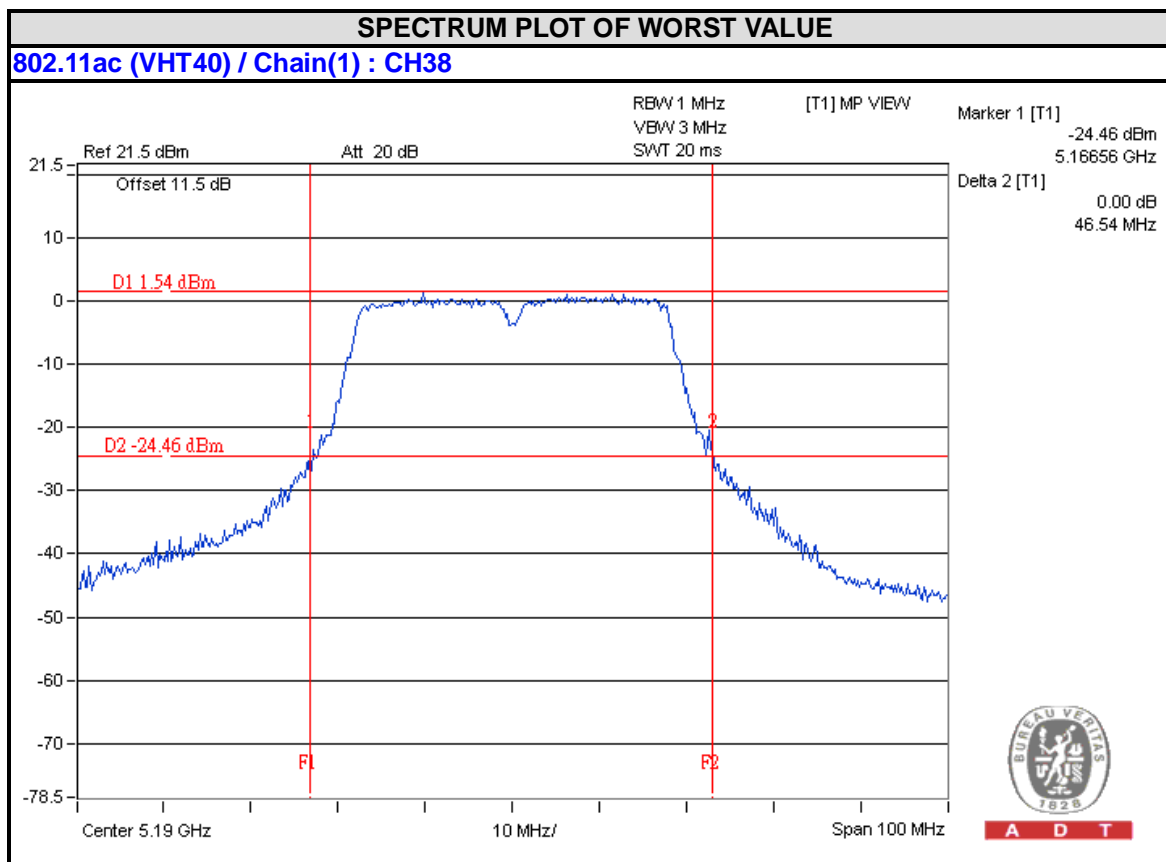





A D T

802.11ac (VHT80)

CHAN.	CHAN. FREQ. (MHz)	AVERAGE POWER (dBm)		TOTAL POWER (mW)	TOTAL POWER (dBm)	POWER LIMIT (dBm)	PASS / FAIL
		CHAIN 0	CHAIN 1				
42	5210	4.84	4.65	5.965	7.76	28.7	PASS
155	5775	5.25	4.98	6.498	8.13	28.7	PASS

Note: The directional gain is 7.3dBi > 6dBi, therefore the limit needs to reduce, so the power limit shall be reduced to "Determined Conducted Limit-(7.3-6)".

26dB OCCUPIED BANDWIDTH:

CHANNEL	CHANNEL FREQUENCY (MHz)	26dBc BANDWIDTH (MHz)	
		CHAIN 0	CHAIN 1
42	5210	89.43	89.76

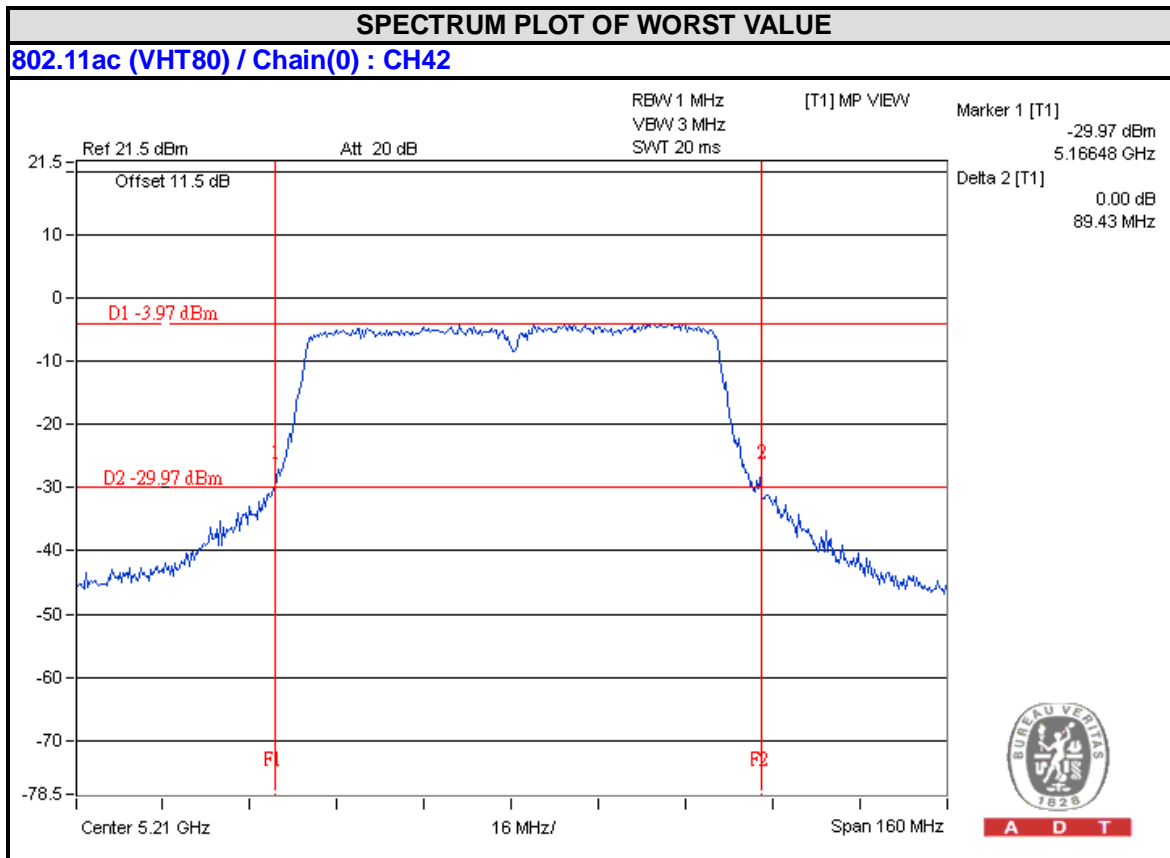



A D T

※Add test for each data rate output power (require by manufacturer):

802.11a

CHANNEL	FREQUENCY (MHz)	AVERAGE POWER (dBm)							
		Data rate							
		6Mbps	9Mbps	12Mbps	18Mbps	24Mbps	36Mbps	48Mbps	54Mbps
36	5180	16.47	16.33	16.39	16.44	16.32	16.33	16.45	16.45
40	5200	18.13	18.06	18.09	18.12	18.03	17.96	17.97	18.03
48	5240	17.87	17.71	17.73	17.74	17.73	17.78	17.68	17.78
149	5745	15.18	15.04	15.01	15.06	15.01	14.98	15.17	15.01
157	5785	18.67	18.59	18.60	18.63	18.57	18.59	18.54	18.59
165	5825	18.92	18.81	18.90	18.75	18.88	18.78	18.82	18.79

802.11n (HT20)

CHANNEL	FREQUENCY (MHz)	AVERAGE POWER (dBm)							
		Data rate							
		MCS0	MCS1	MCS2	MCS3	MCS4	MCS5	MCS6	MCS7
36	5180	14.73	14.55	14.56	14.58	14.70	14.59	14.61	14.63
44	5220	17.89	17.82	17.80	17.80	17.86	17.83	17.71	17.8
48	5240	17.76	17.64	17.65	17.73	17.68	17.72	17.65	17.75
149	5745	15.08	14.97	15.02	15.02	14.95	14.94	15.04	15.01
157	5785	18.88	18.82	18.86	18.76	18.82	18.83	18.84	18.85
165	5825	19.00	18.84	18.87	18.82	18.85	18.8	18.86	18.86

802.11n (HT20)

CHANNEL	FREQUENCY (MHz)	AVERAGE POWER (dBm)							
		Data rate							
		MCS8	MCS9	MCS10	MCS11	MCS12	MCS13	MCS14	MCS15
36	5180	14.68	14.60	14.54	14.64	14.52	14.57	14.49	14.58
44	5220	17.86	17.73	17.84	17.79	17.81	17.76	17.77	17.76
48	5240	17.73	17.70	17.54	17.60	17.69	17.58	17.69	17.62
149	5745	15.06	14.92	15.03	14.89	14.93	15.02	14.87	14.92
157	5785	18.82	18.80	18.65	18.70	18.64	18.67	18.8	18.63
165	5825	19.97	19.78	19.80	19.81	19.84	19.82	19.91	19.94



A D T

**802.11n (HT40)**

CHANNEL	FREQUENCY (MHz)	AVERAGE POWER (dBm)							
		Data rate							
		MCS0	MCS1	MCS2	MCS3	MCS4	MCS5	MCS6	MCS7
38	5190	9.29	9.12	9.10	9.18	9.26	9.22	9.14	9.20
46	5230	17.38	17.25	17.36	17.27	17.28	17.33	17.23	17.32
151	5755	10.14	10.10	9.96	10.10	10.05	10.13	10.04	9.97
159	5795	17.53	17.41	17.52	17.45	17.35	17.33	17.33	17.35

**802.11n (HT40)**

CHANNEL	FREQUENCY (MHz)	AVERAGE POWER (dBm)							
		Data rate							
		MCS8	MCS9	MCS10	MCS11	MCS12	MCS13	MCS14	MCS15
38	5190	9.27	9.12	9.10	9.20	9.14	9.24	9.16	9.24
46	5230	17.25	17.24	17.19	17.05	17.07	17.16	17.09	17.23
151	5755	10.07	9.93	10.05	9.90	9.88	9.92	9.96	9.9
159	5795	17.42	17.33	17.37	17.29	17.23	17.32	17.33	17.25

**802.11ac (VHT20)**

CHANNEL	FREQUENCY (MHz)	AVERAGE POWER (dBm)								
		Data rate								
		MCS0	MCS1	MCS2	MCS3	MCS4	MCS5	MCS6	MCS7	MCS8
36	5180	14.86	14.83	14.74	14.82	14.75	14.71	14.76	14.83	14.70
44	5220	18.04	17.91	18.03	17.97	17.98	17.88	18.01	17.93	17.91
48	5240	17.82	17.64	17.79	17.63	17.66	17.81	17.69	17.73	17.76
149	5745	15.15	14.97	15.08	15.07	15.08	15.09	15.1	15.03	15.04
157	5785	18.93	18.79	18.78	18.87	18.75	18.82	18.73	18.91	18.86
165	5825	19.06	18.91	18.98	18.89	19.05	18.9	18.93	18.96	18.96



**802.11ac (VHT20)**

CHANNEL	FREQUENCY (MHz)	AVERAGE POWER (dBm)								
		Data rate								
		MCS0	MCS1	MCS2	MCS3	MCS4	MCS5	MCS6	MCS7	MCS8
36	5180	14.85	14.74	14.67	14.77	14.73	14.68	14.83	14.84	14.72
44	5220	18.02	17.95	17.86	17.89	17.93	17.96	17.93	17.84	17.85
48	5240	17.75	17.57	17.64	17.61	17.65	17.68	17.72	17.67	17.62
149	5745	15.14	14.95	15.02	15.13	15.02	15.09	15.11	15.09	15.08
157	5785	18.91	18.78	18.76	18.79	18.87	18.86	18.76	18.76	18.85
165	5825	19.04	18.97	19.02	18.85	18.86	18.9	18.99	18.91	18.93

**802.11ac (VHT40)**

CHANNEL	FREQUENCY (MHz)	AVERAGE POWER (dBm)									
		Data rate									
		MCS0	MCS1	MCS2	MCS3	MCS4	MCS5	MCS6	MCS7	MCS8	MCS9
38	5190	9.38	9.20	9.22	9.24	9.29	9.25	9.25	9.31	9.35	9.25
46	5230	17.50	17.45	17.42	17.40	17.43	17.41	17.42	17.35	17.41	17.39
151	5755	10.28	10.15	10.17	10.17	10.16	10.16	10.19	10.23	10.16	10.18
159	5795	17.59	17.43	17.52	17.44	17.47	17.39	17.56	17.4	17.41	17.46

**802.11ac (VHT40)**

CHANNEL	FREQUENCY (MHz)	AVERAGE POWER (dBm)									
		Data rate									
		MCS0	MCS1	MCS2	MCS3	MCS4	MCS5	MCS6	MCS7	MCS8	MCS9
38	5190	9.36	9.31	9.35	9.21	9.34	9.22	9.31	9.18	9.22	9.25
46	5230	17.43	17.40	17.35	17.41	17.32	17.29	17.29	17.35	17.42	17.39
151	5755	10.26	10.09	10.19	10.21	10.09	10.21	10.13	10.08	10.13	10.18
159	5795	17.46	17.42	17.44	17.28	17.36	17.36	17.29	17.28	17.34	17.46



A D T

**802.11ac (VHT80)**

CHANNEL	FREQUENCY (MHz)	AVERAGE POWER (dBm)									
		Data rate									
		MCS0	MCS1	MCS2	MCS3	MCS4	MCS5	MCS6	MCS7	MCS8	MCS9
42	5210	7.76	7.70	7.61	7.70	7.68	7.63	7.69	7.70	7.60	7.70
155	5775	8.13	7.98	7.96	8.01	8	8.05	8.07	7.99	8.07	8.01

**802.11ac (VHT80)**

CHANNEL	FREQUENCY (MHz)	AVERAGE POWER (dBm)									
		Data rate									
		MCS0	MCS1	MCS2	MCS3	MCS4	MCS5	MCS6	MCS7	MCS8	MCS9
42	5210	7.76	7.70	7.61	7.70	7.68	7.63	7.69	7.70	7.60	7.70
155	5775	8.13	7.98	7.96	8.01	8	8.05	8.07	7.99	8.07	8.01

#### 4.4 PEAK POWER SPECTRAL DENSITY MEASUREMENT

##### 4.4.1 LIMITS OF PEAK POWER SPECTRAL DENSITY MEASUREMENT

Operation Band	EUT Category		LIMIT
U-NII-1		Outdoor Access Point	17dBm/ MHz
		Fixed point-to-point Access Point	
	√	Indoor Access Point	
		Mobile and Portable client device	11dBm/ MHz
U-NII-2A	---		11dBm/ MHz
U-NII-2C	---		11dBm/ MHz
U-NII-3	---		30dBm/ 500kHz

##### 4.4.2 TEST INSTRUMENTS

DESCRIPTION & MANUFACTURER	MODEL NO.	SERIAL NO.	CALIBRATED DATE	CALIBRATED UNTIL
SPECTRUM ANALYZER R&S	FSV 40	100964	July 05, 2014	July 04, 2015

**Note:**

1. The calibration interval of the above test instruments is 12 months and the calibrations are traceable to NML/ROC and NIST/USA.
2. Tested date : Aug. 04, 2014

#### 4.4.3 TEST PROCEDURES

Using method SA-1

**For U-NII-1:**

1. Set span to encompass the entire emission bandwidth (EBW) of the signal.
2. Set RBW = 1 MHz, Set VBW  $\geq$  3 MHz, Detector = RMS
3. Sweep time = auto, trigger set to “free run”.
4. Trace average at least 100 traces in power averaging mode.
5. Record the max value and for duty cycle of test signal is  $<$  98% add 10 log (1/duty cycle)

**For U-NII-3:**

1. Set span to encompass the entire emission bandwidth (EBW) of the signal.
2. Set RBW = 300 kHz, Set VBW  $\geq$  1 MHz, Detector = RMS
3. Use the peak marker function to determine the maximum power level in any 300 kHz band segment within the fundamental EBW.
4. Scale the observed power level to an equivalent value in 500 kHz by adjusting (reducing) the measured power by a bandwidth correction factor (BWCF) where  $BWCF = 10\log(500\text{ kHz}/300\text{ kHz})$
5. Sweep time = auto, trigger set to “free run”.
6. Trace average at least 100 traces in power averaging mode.
7. Record the max value and for duty cycle of test signal is  $<$  98% add 10 log (1/duty cycle)



A D T

#### 4.4.4 DEVIATION FROM TEST STANDARD

No deviation

#### 4.4.5 TEST SETUP

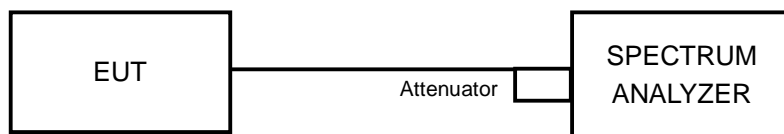

#### 4.4.6 EUT OPERATING CONDITIONS

Same as 4.3.6





A D T

### 4.4.7 TEST RESULTS

For U-NII-1:

#### 802.11a

CHANNEL	CHANNEL FREQUENCY (MHz)	PSD (dBm)		TOTAL POWER DENSITY (dBm)	MAX. LIMIT (dBm)	PASS/FAIL
		CHAIN 0	CHAIN 1			
36	5180	-0.49	-1.16	2.20	12.73	PASS
40	5200	1.77	1.59	4.69	12.73	PASS
48	5240	1.45	1.28	4.38	12.73	PASS

**NOTE:** 1. Method a) of power density measurement of KDB 662911 is using for calculating total power density. Total power density is summing entire spectra across corresponding frequency bins on the various outputs by computer.

2. **5150~5250MHz:** Directional gain =  $10 \log[(10^{G1/20} + 10^{G2/20})^2 / 2] = 10.27\text{dBi} > 6\text{dBi}$ , so the power density limit shall be reduced to  $17-(10.27-6) = 12.73\text{dBm}$ .

#### 802.11ac (VHT20)

CHANNEL	CHANNEL FREQUENCY (MHz)	PSD (dBm)		TOTAL POWER DENSITY (dBm)	MAX. LIMIT (dBm)	PASS/FAIL
		CHAIN 0	CHAIN 1			
36	5180	-1.78	-2.00	1.12	12.73	PASS
40	5200	1.29	1.19	4.25	12.73	PASS
48	5240	1.16	0.81	4.00	12.73	PASS

**NOTE:** 1. Method a) of power density measurement of KDB 662911 is using for calculating total power density. Total power density is summing entire spectra across corresponding frequency bins on the various outputs by computer.

2. **5150~5250MHz:** Directional gain =  $10 \log[(10^{G1/20} + 10^{G2/20})^2 / 2] = 10.27\text{dBi} > 6\text{dBi}$ , so the power density limit shall be reduced to  $17-(10.27-6) = 12.73\text{dBm}$ .

**802.11ac (VHT40)**

CHANNEL	CHANNEL FREQUENCY (MHz)	PSD (dBm)		TOTAL POWER DENSITY (dBm)	MAX. LIMIT (dBm)	PASS/FAIL
		CHAIN 0	CHAIN 1			
38	5190	-10.16	-10.18	-7.16	12.73	PASS
46	5230	-1.08	-1.36	1.79	12.73	PASS

- NOTE:** 1. Method a) of power density measurement of KDB 662911 is using for calculating total power density. Total power density is summing entire spectra across corresponding frequency bins on the various outputs by computer.
2. **5150~5250MHz:** Directional gain =  $10 \log[(10^{G1/20} + 10^{G2/20})^2 / 2] = 10.27\text{dBi} > 6\text{dBi}$  , so the power density limit shall be reduced to  $17-(10.27-6) = 12.73\text{dBm}$ .

**802.11ac (VHT80)**

CHANNEL	CHANNEL FREQUENCY (MHz)	PSD (dBm)		TOTAL POWER DENSITY (dBm)	MAX. LIMIT (dBm)	PASS/FAIL
		CHAIN 0	CHAIN 1			
42	5210	-14.87	-15.56	-12.19	12.73	PASS

- NOTE:** 1. Method a) of power density measurement of KDB 662911 is using for calculating total power density. Total power density is summing entire spectra across corresponding frequency bins on the various outputs by computer.
2. **5150~5250MHz:** Directional gain =  $10 \log[(10^{G1/20} + 10^{G2/20})^2 / 2] = 10.27\text{dBi} > 6\text{dBi}$  , so the power density limit shall be reduced to  $17-(10.27-6) = 12.73\text{dBm}$ .



A D T

### SPECTRUM PLOT OF WORST VALUE

#### 802.11a / Chain(0) : CH40

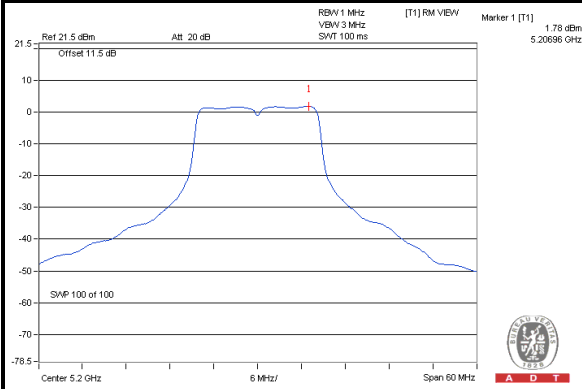

#### 802.11ac (VHT20) / Chain(0) : CH40

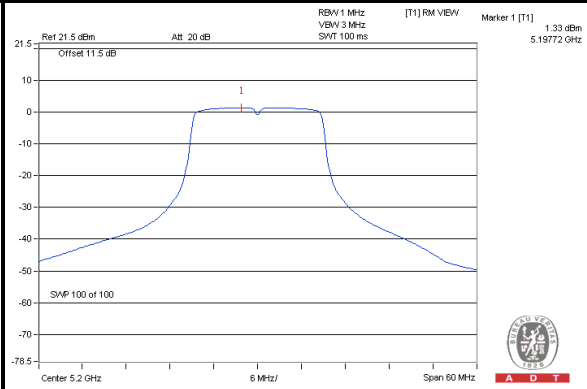

#### 802.11ac (VHT40) / Chain(0) : CH46

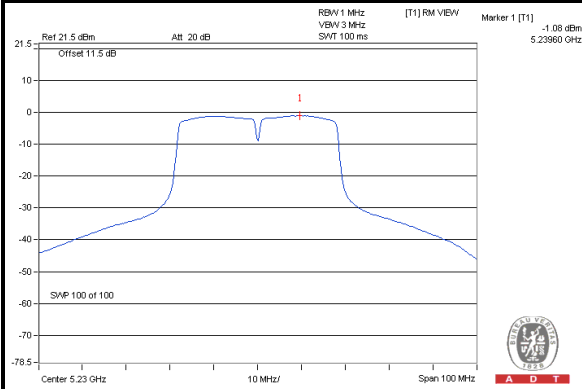

#### 802.11ac (VHT80) / Chain(0) : CH42

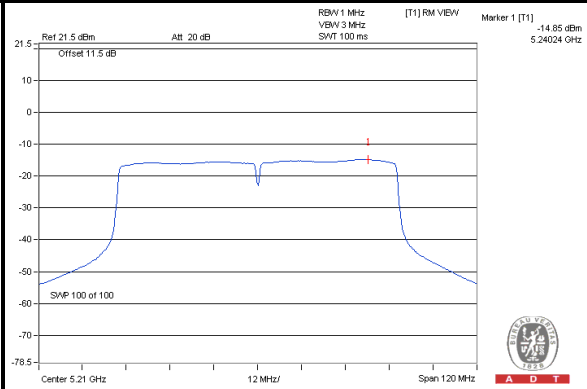



A D T

For U-NII-3:

802.11a

TX CHAIN	CHANNEL	FREQUENCY (MHz)	PSD (dBm/300kHz)	PSD (dBm/500kHz)	10 log (N=2) dB	TOTAL PSD (dBm/500kHz)	LIMIT (dBm/500kHz)	PASS /FAIL
0	149	5745	-8.95	-6.73	3.01	-3.72	25.73	PASS
	157	5785	-6.66	-4.44	3.01	-1.43	25.73	PASS
	165	5825	-6.11	-3.89	3.01	-0.88	25.73	PASS
1	149	5745	-9.15	-6.93	3.01	-3.92	25.73	PASS
	157	5785	-6.58	-4.36	3.01	-1.35	25.73	PASS
	165	5825	-5.86	-3.64	3.01	-0.63	25.73	PASS

**NOTE:** 1. 5725~5825MHz: Directional gain =  $10 \log[(10^{G1/20} + 10^{G2/20})^2 / 2] = 10.27\text{dBi} > 6\text{dBi}$  , so the power density limit shall be reduced to  $30-(10.27-6) = 25.73\text{dBm}$ .

802.11ac (VHT20)

TX CHAIN	CHANNEL	FREQUENCY (MHz)	PSD (dBm/300kHz)	PSD (dBm/500kHz)	10 log (N=2) dB	TOTAL PSD (dBm/500kHz)	LIMIT (dBm/500kHz)	PASS /FAIL
0	149	5745	-9.67	-7.45	3.01	-4.44	25.73	PASS
	157	5785	-7.12	-4.90	3.01	-1.89	25.73	PASS
	165	5825	-6.41	-4.19	3.01	-1.18	25.73	PASS
1	149	5745	-9.22	-7.00	3.01	-3.99	25.73	PASS
	157	5785	-6.99	-4.77	3.01	-1.76	25.73	PASS
	165	5825	-6.20	-3.98	3.01	-0.97	25.73	PASS

**NOTE:** 1. 5725~5825MHz: Directional gain =  $10 \log[(10^{G1/20} + 10^{G2/20})^2 / 2] = 10.27\text{dBi} > 6\text{dBi}$  , so the power density limit shall be reduced to  $30-(10.27-6) = 25.73\text{dBm}$ .

802.11ac (VHT40)

TX CHAIN	CHANNEL	FREQUENCY (MHz)	PSD (dBm/300kHz)	PSD (dBm/500kHz)	10 log (N=2) dB	TOTAL PSD (dBm/500kHz)	LIMIT (dBm/500kHz)	PASS /FAIL
0	151	5755	-17.73	-15.51	3.01	-12.50	25.73	PASS
	159	5795	-11.36	-9.14	3.01	-6.13	25.73	PASS
1	151	5755	-17.87	-15.65	3.01	-12.64	25.73	PASS
	159	5795	-11.54	-9.32	3.01	-6.31	25.73	PASS

**NOTE:** 1. 5725~5825MHz: Directional gain =  $10 \log[(10^{G1/20} + 10^{G2/20})^2 / 2] = 10.27\text{dBi} > 6\text{dBi}$  , so the power density limit shall be reduced to  $30-(10.27-6) = 25.73\text{dBm}$ .



A D T

802.11ac (VHT80)

TX CHAIN	CHANNEL	FREQUENCY (MHz)	PSD (dBm/300kHz)	PSD (dBm/500kHz)	10 log (N=2) dB	TOTAL PSD (dBm/500kHz)	LIMIT (dBm/500kHz)	PASS /FAIL
0	155	5775	-23.17	-20.95	3.01	-17.94	25.73	PASS
1	155	5775	-23.52	-21.30	3.01	-18.29	25.73	PASS

**NOTE:** 1. 5725~5825MHz: Directional gain =  $10 \log[(10^{G1/20} + 10^{G2/20})^2 / 2] = 10.27\text{dBi} > 6\text{dBi}$  , so the power density limit shall be reduced to  $30-(10.27-6) = 25.73\text{dBm}$ .

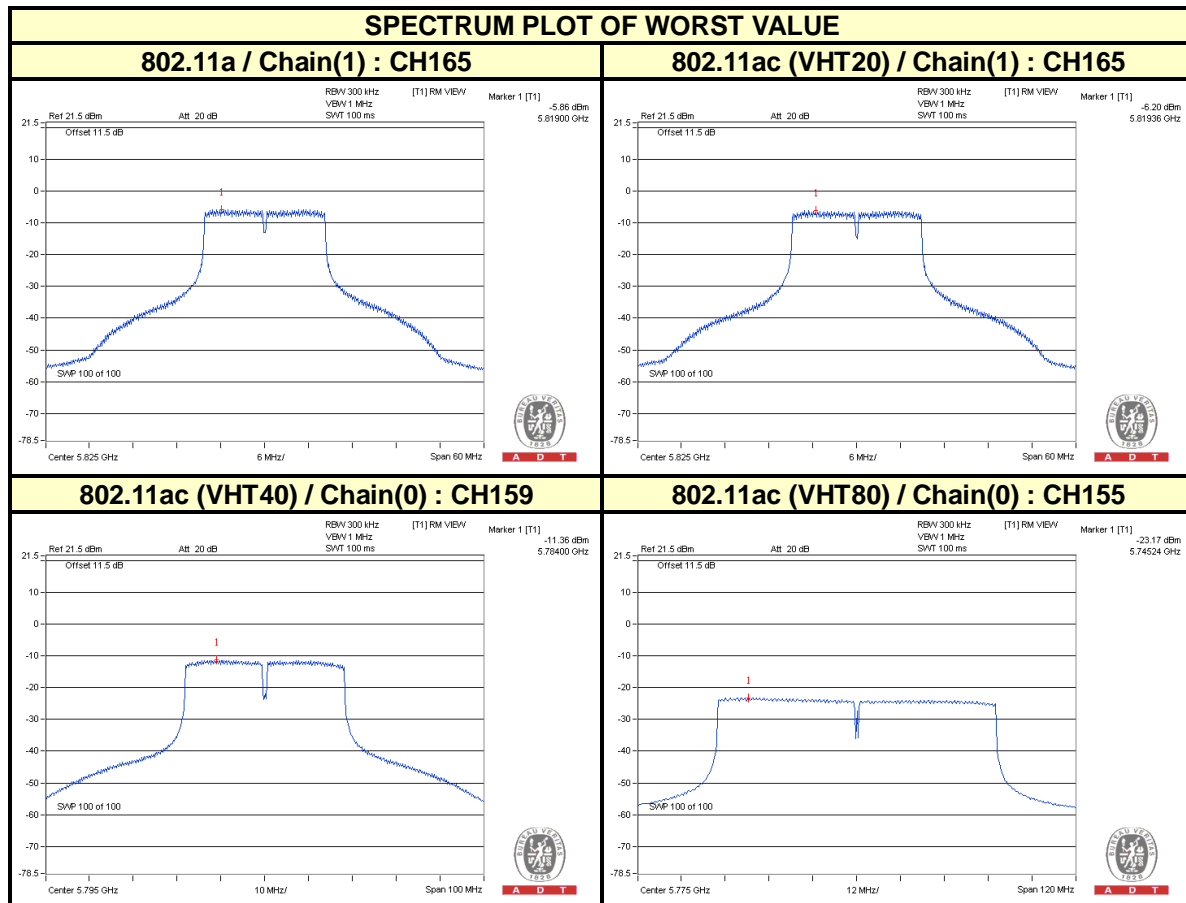



A D T

## 4.5 FREQUENCY STABILITY

### 4.5.1 LIMITS OF FREQUENCY STABILITY MEASUREMENT

The frequency of the carrier signal shall be maintained within band of operation

### 4.5.2 TEST INSTRUMENTS

DESCRIPTION & MANUFACTURER	MODEL NO.	SERIAL NO.	CALIBRATED DATE	CALIBRATED UNTIL
SPECTRUM ANALYZER R&S	FSV 40	100964	July 05, 2014	July 04, 2015
Temperature Humidity Chamber GIANTFORCE	& GTH-150-40-SP -AR	MAA0812-008	Jan. 13, 2014	Jan. 12, 2015

**Note:**

1. The calibration interval of the above test instruments is 12 months and the calibrations are traceable to NML/ROC and NIST/USA.
2. Tested date : Aug. 04, 2014

### 4.5.3 TEST PROCEDURE

1. The EUT was placed inside the environmental test chamber and powered by nominal AC voltage.
2. Turn the EUT on and couple its output to a spectrum analyzer.
3. Turn the EUT off and set the chamber to the highest temperature specified.
4. Allow sufficient time (approximately 30 min) for the temperature of the chamber to stabilize, turn the EUT on and measure the operating frequency after 2, 5, and 10 minutes.
5. Repeat step 2 and 3 with the temperature chamber set to the lowest temperature.
6. The test chamber was allowed to stabilize at +20 degree C for a minimum of 30 minutes. The supply voltage was then adjusted on the EUT from 85% to 115% and the frequency record.

#### 4.5.4 DEVIATION FROM TEST STANDARD

No deviation

#### 4.5.5 TEST SETUP

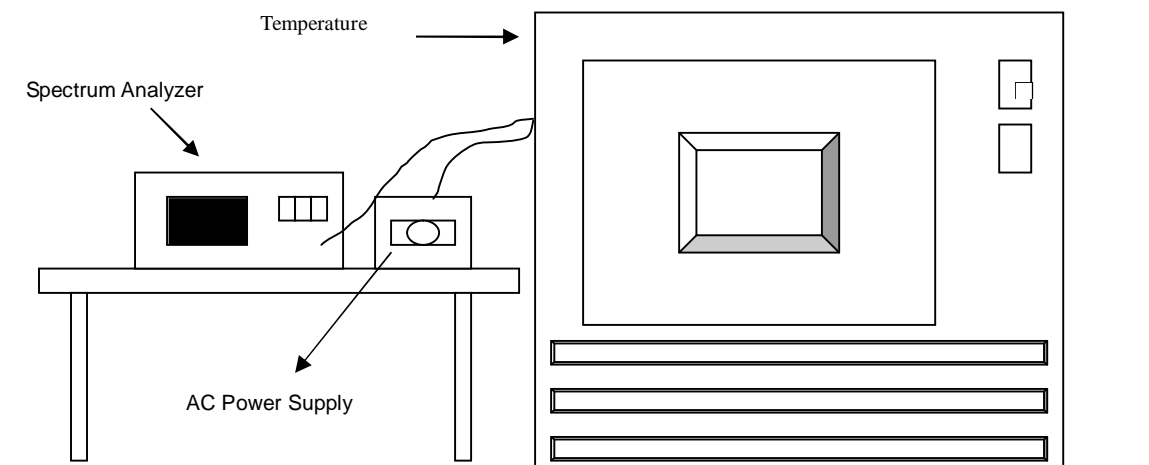

#### 4.5.6 EUT OPERATING CONDITION

Set the EUT transmit at un-modulation mode to test frequency stability.



A D T

### 4.5.7 TEST RESULTS

FREQUENCY STABILITY VERSUS TEMP.									
OPERATING FREQUENCY: 5240MHz									
TEMP. (°C)	POWER SUPPLY (Vac)	0 MINUTE		2 MINUTE		5 MINUTE		10 MINUTE	
		Measured Frequency	Frequency Drift	Measured Frequency	Frequency Drift	Measured Frequency	Frequency Drift	Measured Frequency	Frequency Drift
		(MHz)	%	(MHz)	%	(MHz)	%	(MHz)	%
50	120	5240.0119	0.00023	5240.0119	0.00023	5240.0105	0.00020	5240.0121	0.00023
40	120	5239.9853	-0.00028	5239.9826	-0.00033	5239.9837	-0.00031	5239.9855	-0.00028
30	120	5239.9834	-0.00032	5239.9856	-0.00027	5239.9852	-0.00028	5239.985	-0.00029
20	120	5240.0227	0.00043	5240.0244	0.00047	5240.0237	0.00045	5240.0257	0.00049
10	120	5239.9944	-0.00011	5239.9921	-0.00015	5239.9899	-0.00019	5239.9905	-0.00018
0	120	5239.9851	-0.00028	5239.9878	-0.00023	5239.9854	-0.00028	5239.986	-0.00027
-10	120	5239.9818	-0.00035	5239.981	-0.00036	5239.9811	-0.00036	5239.978	-0.00042
-20	120	5240.0196	0.00037	5240.017	0.00032	5240.0167	0.00032	5240.0175	0.00033
-30	120	5240.0038	0.00007	5240.0025	0.00005	5240.0025	0.00005	5240.0022	0.00004

FREQUENCY STABILITY VERSUS VOLTAGE									
OPERATING FREQUENCY: 5240MHz									
TEMP. (°C)	POWER SUPPLY (Vac)	0 MINUTE		2 MINUTE		5 MINUTE		10 MINUTE	
		Measured Frequency	Frequency Drift	Measured Frequency	Frequency Drift	Measured Frequency	Frequency Drift	Measured Frequency	Frequency Drift
		(MHz)	%	(MHz)	%	(MHz)	%	(MHz)	%
20	138	5240.0234	0.00045	5240.0234	0.00045	5240.0233	0.00044	5240.0256	0.00049
	120	5240.0227	0.00043	5240.0244	0.00047	5240.0237	0.00045	5240.0257	0.00049
	102	5240.0237	0.00045	5240.0253	0.00048	5240.0228	0.00044	5240.0264	0.00050



## 4.6 6dB BANDWIDTH MEASUREMENT

### 4.6.1 LIMITS OF 6dB BANDWIDTH MEASUREMENT

The minimum of 6dB Bandwidth Measurement is 0.5 MHz.

### 4.6.2 TEST INSTRUMENTS

DESCRIPTION & MANUFACTURER	MODEL NO.	SERIAL NO.	CALIBRATED DATE	CALIBRATED UNTIL
SPECTRUM ANALYZER R&S	FSV 40	100964	July 05, 2014	July 04, 2015

**Note:**

1. The calibration interval of the above test instruments is 12 months and the calibrations are traceable to NML/ROC and NIST/USA.
2. Tested date : Aug. 01, 2014

### 4.6.3 TEST PROCEDURE

1. Set resolution bandwidth (RBW) = 100kHz.
2. Set the video bandwidth (VBW)  $\geq 3 \times$  RBW, Detector = Peak.
3. Trace mode = max hold.
4. Sweep = auto couple.
5. Measure the maximum width of the emission that is constrained by the frequencies associated with the two amplitude points (upper and lower) that are attenuated by 6 dB relative to the maximum level measured in the fundamental emission

### 4.6.4 DEVIATION FROM TEST STANDARD

No deviation

### 4.6.5 TEST SETUP

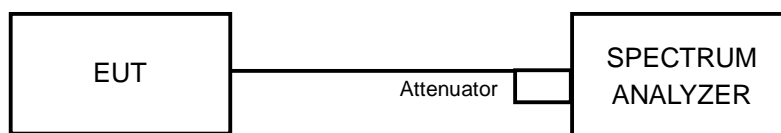

### 4.6.6 EUT OPERATING CONDITIONS

The software provided by client to enable the EUT under transmission condition continuously at lowest, middle and highest channel frequencies individually.



A D T

#### 4.6.7 TEST RESULTS

##### 802.11a

CHANNEL	CHANNEL FREQUENCY (MHz)	6dB BANDWIDTH (MHz)		MINIMUM LIMIT (MHz)	PASS / FAIL
		CHAIN 0	CHAIN 1		
149	5745	16.37	16.42	0.5	PASS
157	5785	16.43	16.41	0.5	PASS
165	5825	16.41	16.43	0.5	PASS

##### 802.11ac (VHT20)

CHANNEL	CHANNEL FREQUENCY (MHz)	6dB BANDWIDTH (MHz)		MINIMUM LIMIT (MHz)	PASS / FAIL
		CHAIN 0	CHAIN 1		
149	5745	17.68	17.59	0.5	PASS
157	5785	17.67	17.63	0.5	PASS
165	5825	17.62	17.61	0.5	PASS

##### 802.11ac (VHT40)

CHANNEL	CHANNEL FREQUENCY (MHz)	6dB BANDWIDTH (MHz)		MINIMUM LIMIT (MHz)	PASS / FAIL
		CHAIN 0	CHAIN 1		
151	5755	36.12	36.17	0.5	PASS
159	5795	36.45	36.40	0.5	PASS

##### 802.11ac (VHT80)

CHANNEL	CHANNEL FREQUENCY (MHz)	6dB BANDWIDTH (MHz)		MINIMUM LIMIT (MHz)	PASS / FAIL
		CHAIN 0	CHAIN 1		
155	5775	76.19	75.81	0.5	PASS



A D T

### SPECTRUM PLOT OF WORST VALUE

#### 802.11a / Chain(0) : CH149

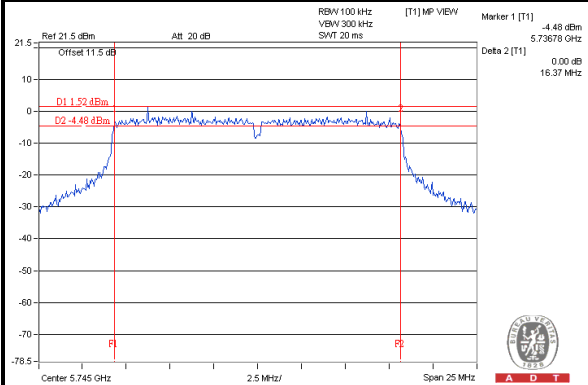

#### 802.11ac (VHT20) / Chain(1) : CH149

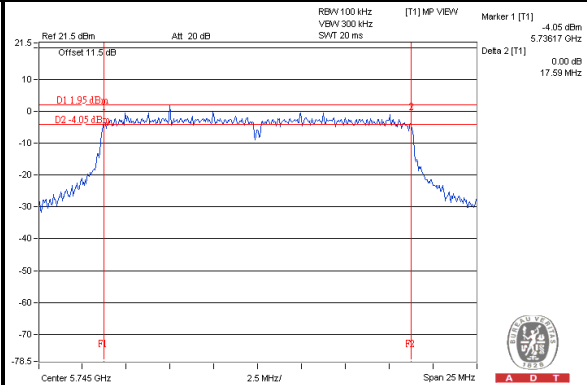

#### 802.11ac (VHT40) / Chain(0) : CH151

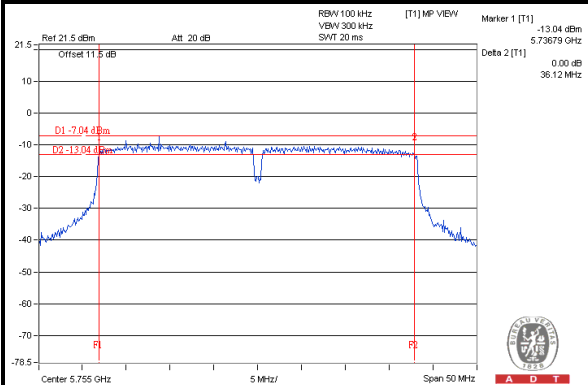

#### 802.11ac (VHT80) / Chain(1) : CH155

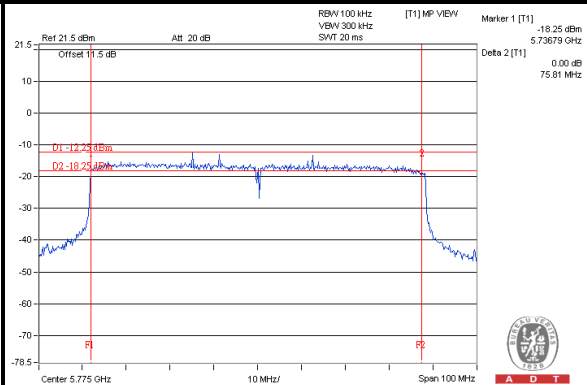



A D T

## 5. PHOTOGRAPHS OF THE TEST CONFIGURATION

Please refer to the attached file (Test Setup Photo).





## 6. INFORMATION ON THE TESTING LABORATORIES

We, Bureau Veritas Consumer Products Services (H.K.) Ltd., Taoyuan Branch, were founded in 1988 to provide our best service in EMC, Radio, Telecom and Safety consultation. Our laboratories are accredited and approved according to ISO/IEC 17025.

If you have any comments, please feel free to contact us at the following:

**Linko EMC/RF Lab:**

Tel: 886-2-26052180

Fax: 886-2-26052943

**Hsin Chu EMC/RF Lab:**

Tel: 886-3-5935343

Fax: 886-3-5935342

**Hwa Ya EMC/RF/Safety/Telecom Lab:**

Tel: 886-3-3183232

Fax: 886-3-3270892

**Email:** [service.adt@tw.bureauveritas.com](mailto:service.adt@tw.bureauveritas.com)

**Web Site:** [www.bureauveritas-adt.com](http://www.bureauveritas-adt.com)

The address and road map of all our labs can be found in our web site also.



A D T

## **7. APPENDIX A - MODIFICATIONS RECORDERS FOR ENGINEERING CHANGES TO THE EUT BY THE LAB**

No modifications were made to the EUT by the lab during the test.

**--- END ---**