



# FCC TEST REPORT (15.247)

**REPORT NO.:** RF980406H01A

**MODEL NO.:** AP-7131N

**RECEIVED:** April 06, 2009

**TESTED:** June 05 to 18, 2009

**ISSUED:** July 10, 2009

**APPLICANT:** Motorola Inc.

**ADDRESS:** One Symbol Plaza Holtsville, NY11742 USA

**ISSUED BY:** Bureau Veritas Consumer Products Services (H.K.) Ltd., Taoyuan Branch Hsin Chu Laboratory

**ADDRESS:** No. 81-1, Lu Liao Keng, 9th Ling, Wu Lung Tsuen, Chiung Lin Hsiang, Hsin Chu Hsien 307, Taiwan

This test report consists of 657 pages in total. It may be duplicated completely for legal use with the approval of the applicant. It should not be reproduced except in full, without the written approval of our laboratory. The client should not use it to claim product endorsement by TAF or any government agencies. The test results in the report only apply to the tested sample.





A D T

## Table of Contents

1.	CERTIFICATION .....	7
2.	SUMMARY OF TEST RESULTS .....	8
2.1	MEASUREMENT UNCERTAINTY .....	10
3.	GENERAL INFORMATION .....	11
3.1	GENERAL DESCRIPTION OF EUT .....	11
3.2	DESCRIPTION OF TEST MODES .....	16
3.2.1	TEST MODE APPLICABILITY AND TESTED CHANNEL DETAIL: .....	17
3.3	GENERAL DESCRIPTION OF APPLIED STANDARDS .....	22
3.4	DESCRIPTION OF SUPPORT UNITS.....	23
3.5	CONFIGURATION OF SYSTEM UNDER TEST .....	24
4.	TEST TYPES AND RESULTS (802.11b & g, 2400 ~ 2483.5MHz Band) .....	25
4.1	CONDUCTED EMISSION MEASUREMENT .....	25
4.1.1	LIMITS OF CONDUCTED EMISSION MEASUREMENT .....	25
4.1.2	TEST INSTRUMENTS.....	25
4.1.3	TEST PROCEDURES .....	26
4.1.4	DEVIATION FROM TEST STANDARD .....	26
4.1.5	TEST SETUP .....	27
4.1.6	EUT OPERATING CONDITIONS .....	27
4.1.7	TEST RESULTS .....	28
4.2	RADIATED EMISSION MEASUREMENT .....	32
4.2.1	LIMITS OF RADIATED EMISSION MEASUREMENT .....	32
4.2.2	TEST INSTRUMENTS.....	33
4.2.3	TEST PROCEDURES .....	34
4.2.4	DEVIATION FROM TEST STANDARD .....	34
4.2.5	TEST SETUP .....	35
4.2.6	EUT OPERATING CONDITIONS .....	35
4.2.7	TEST RESULTS –ANTENNA 1.....	36
4.2.8	TEST RESULTS –ANTENNA 2.....	65
4.2.9	TEST RESULTS –ANTENNA 4.....	94
4.2.10	TEST RESULTS –ANTENNA 6.....	123
4.2.11	TEST RESULTS –ANTENNA 8.....	152
4.2.12	TEST RESULTS –ANTENNA 12.....	181
4.3	6dB BANDWIDTH MEASUREMENT .....	189
4.3.1	LIMITS OF 6dB BANDWIDTH MEASUREMENT .....	189
4.3.2	TEST INSTRUMENTS.....	189
4.3.3	TEST PROCEDURE.....	190
4.3.4	DEVIATION FROM TEST STANDARD .....	190
4.3.5	TEST SETUP .....	190
4.3.6	EUT OPERATING CONDITIONS .....	190



4.3.7	TEST RESULTS - ANTENNA 1.....	191
4.3.8	TEST RESULTS - ANTENNA 2.....	199
4.3.9	TEST RESULTS - ANTENNA 4.....	207
4.3.10	TEST RESULTS - ANTENNA 6.....	215
4.3.11	TEST RESULTS - ANTENNA 8.....	223
4.3.12	TEST RESULTS - ANTENNA 12.....	231
4.4	MAXIMUM PEAK OUTPUT POWER.....	233
4.4.1	LIMITS OF MAXIMUM PEAK OUTPUT POWER MEASUREMENT .....	233
4.4.2	INSTRUMENTS.....	233
4.4.3	TEST PROCEDURES .....	233
4.4.4	DEVIATION FROM TEST STANDARD .....	233
4.4.5	TEST SETUP .....	233
4.4.6	EUT OPERATING CONDITIONS .....	234
4.4.7	TEST RESULTS –ANTENNA 1.....	235
4.4.8	TEST RESULTS –ANTENNA 2.....	237
4.4.9	TEST RESULTS –ANTENNA 4.....	239
4.4.10	TEST RESULTS –ANTENNA 6.....	241
4.4.11	TEST RESULTS –ANTENNA 8.....	243
4.4.12	TEST RESULTS –ANTENNA 12.....	245
4.5	POWER SPECTRAL DENSITY MEASUREMENT.....	246
4.5.1	LIMITS OF POWER SPECTRAL DENSITY MEASUREMENT .....	246
4.5.2	TEST INSTRUMENTS.....	246
4.5.3	TEST PROCEDURE.....	247
4.5.4	DEVIATION FROM TEST STANDARD .....	247
4.5.5	TEST SETUP .....	247
4.5.6	EUT OPERATING CONDITION.....	247
4.5.7	TEST RESULTS - ANTENNA 1.....	248
4.5.8	TEST RESULTS - ANTENNA 2.....	272
4.5.9	TEST RESULTS - ANTENNA 4.....	296
4.5.10	TEST RESULTS - ANTENNA 6.....	320
4.5.11	TEST RESULTS - ANTENNA 8.....	344
4.5.12	TEST RESULTS - ANTENNA 12.....	368
4.6	CONDUCTED OUT-BAND EMISSION MEASUREMENT.....	370
4.6.1	LIMITS OF CONDUCTED OUT-BAND EMISSION MEASUREMENT.....	370
4.6.2	TEST INSTRUMENTS.....	370
4.6.3	TEST PROCEDURE.....	370
4.6.4	DEVIATION FROM TEST STANDARD .....	371
4.6.5	EUT OPERATING CONDITION.....	371
4.6.6	TEST RESULTS- ANTENNA 1.....	371
4.6.7	TEST RESULTS- ANTENNA 2.....	380
4.6.8	TEST RESULTS- ANTENNA 4.....	389



4.6.9	TEST RESULTS- ANTENNA 6.....	398
4.6.10	TEST RESULTS- ANTENNA 8.....	407
4.6.11	TEST RESULTS- ANTENNA 12.....	416
4.7	ANTENNA REQUIREMENT .....	419
4.7.1	STANDARD APPLICABLE.....	419
4.7.2	ANTENNA CONNECTED CONSTRUCTION.....	419
5.	TEST TYPES AND RESULTS (802.11a, 5725~5850MHz Band).....	421
5.1	CONDUCTED EMISSION MEASUREMENT .....	421
5.1.1	LIMITS OF CONDUCTED EMISSION MEASUREMENT.....	421
5.1.2	TEST INSTRUMENTS.....	421
5.1.3	TEST PROCEDURES .....	422
5.1.4	DEVIATION FROM TEST STANDARD.....	422
5.1.5	TEST SETUP .....	423
5.1.6	EUT OPERATING CONDITIONS .....	423
5.1.7	TEST RESULTS .....	424
5.2	RADIATED EMISSION MEASUREMENT .....	428
5.2.1	LIMITS OF RADIATED EMISSION MEASUREMENT.....	428
5.2.2	TEST INSTRUMENTS.....	429
5.2.3	TEST PROCEDURES .....	430
5.2.4	DEVIATION FROM TEST STANDARD.....	430
5.2.5	TEST SETUP .....	431
5.2.6	EUT OPERATING CONDITIONS .....	431
5.2.7	TEST RESULTS –ANTENNA 4.....	432
5.2.8	TEST RESULTS –ANTENNA 5.....	441
5.2.9	TEST RESULTS –ANTENNA 7.....	450
5.2.10	TEST RESULTS –ANTENNA 8.....	459
5.2.11	TEST RESULTS –ANTENNA 11.....	468
5.2.12	TEST RESULTS –ANTENNA 12.....	477
5.3	6dB BANDWIDTH MEASUREMENT .....	481
5.3.1	LIMITS OF 6dB BANDWIDTH MEASUREMENT .....	481
5.3.2	TEST INSTRUMENTS.....	481
5.3.3	TEST PROCEDURE.....	482
5.3.4	DEVIATION FROM TEST STANDARD.....	482
5.3.5	TEST SETUP .....	482
5.3.6	EUT OPERATING CONDITIONS .....	482
5.3.7	TEST RESULTS –ANTENNA 4.....	483
5.3.8	TEST RESULTS –ANTENNA 5.....	489
5.3.9	TEST RESULTS –ANTENNA 7.....	495
5.3.10	TEST RESULTS –ANTENNA 8.....	501
5.3.11	TEST RESULTS –ANTENNA 11.....	507
5.3.12	TEST RESULTS –ANTENNA 12.....	513



A D T

5.4	MAXIMUM PEAK OUTPUT POWER.....	515
5.4.1	LIMITS OF MAXIMUM PEAK OUTPUT POWER MEASUREMENT .....	515
5.4.2	INSTRUMENTS.....	515
5.4.3	TEST PROCEDURES .....	515
5.4.4	DEVIATION FROM TEST STANDARD .....	515
5.4.5	TEST SETUP .....	515
5.4.6	EUT OPERATING CONDITIONS .....	515
5.4.7	TEST RESULTS-ANTENNA 4 .....	516
5.4.8	TEST RESULTS-ANTENNA 5 .....	518
5.4.9	TEST RESULTS-ANTENNA 7 .....	520
5.4.10	TEST RESULTS-ANTENNA 8 .....	522
5.4.11	TEST RESULTS-ANTENNA 11.....	524
5.4.12	TEST RESULTS-ANTENNA 12 .....	526
5.5	POWER SPECTRAL DENSITY MEASUREMENT.....	527
5.5.1	LIMITS OF POWER SPECTRAL DENSITY MEASUREMENT .....	527
5.5.2	TEST INSTRUMENTS.....	527
5.5.3	TEST PROCEDURE.....	528
5.5.4	DEVIATION FROM TEST STANDARD .....	528
5.5.5	TEST SETUP .....	528
5.5.6	EUT OPERATING CONDITION.....	528
5.5.7	TEST RESULTS – ANTENNA 4 .....	529
5.5.8	TEST RESULTS – ANTENNA 5.....	545
5.5.9	TEST RESULTS – ANTENNA 7 .....	561
5.5.10	TEST RESULTS – ANTENNA 8.....	577
5.5.11	TEST RESULTS – ANTENNA 11 .....	593
5.5.12	TEST RESULTS – ANTENNA 12.....	609
5.6	CONDUCTED OUT-BAND EMISSION MEASUREMENT.....	611
5.6.1	LIMITS OF CONDUCTED OUT-BAND EMISSION MEASUREMENT.....	611
5.6.2	TEST INSTRUMENTS.....	611
5.6.3	TEST PROCEDURE.....	612
5.6.4	DEVIATION FROM TEST STANDARD .....	612
5.6.5	EUT OPERATING CONDITION.....	612
5.6.6	TEST RESULTS - ANTENNA 4.....	613
5.6.7	TEST RESULTS - ANTENNA 5.....	620
5.6.8	TEST RESULTS - ANTENNA 7.....	627
5.6.9	TEST RESULTS - ANTENNA 8.....	634
5.6.10	TEST RESULTS - ANTENNA 11 .....	641
5.6.11	TEST RESULTS - ANTENNA 12.....	648
5.7	ANTENNA REQUIREMENT .....	651
5.7.1	STANDARD APPLICABLE.....	651
5.7.2	ANTENNA CONNECTED CONSTRUCTION.....	651



A D T

6.	INFORMATION ON THE TESTING LABORATORIES .....	653
7.	APPENDIX-A- MODIFICATIONS RECORDERS FOR ENGINEERING CHANGES TO THE EUT BY THE LAB.....	654
8.	APPENDIX-B- POWER MEASUREMENT FOR EACH DATA RATE .....	655





## 1. CERTIFICATION

**PRODUCT:** 11n Access-Point  
**BRAND NAME:** Motorola  
**MODEL NO.:** AP-7131N  
**TEST SAMPLE:** R&D SAMPLE  
**TESTED:** June 05 to 18, 2009  
**APPLICANT:** Motorola Inc.  
**STANDARDS:** FCC Part 15, Subpart C (Section 15.247),  
ANSI C63.4-2003

The above equipment (Model: AP-7131N) has been tested by **Bureau Veritas Consumer Products Services (H.K.) Ltd., Taoyuan Branch**, and found compliance with the requirement of the above standards. The test record, data evaluation & Equipment Under Test (EUT) configurations represented herein are true and accurate accounts of the measurements of the sample's EMC characteristics under the conditions specified in this report.

**PREPARED BY** : Midoli Peng , **DATE:** July 10, 2009  
( Midoli Peng, Specialist )

**TECHNICAL ACCEPTANCE** : Hank Chung , **DATE:** July 10, 2009  
Responsible for RF ( Hank Chung, Deputy Manager )

**APPROVED BY** : May Chen , **DATE:** July 10, 2009  
( May Chen, Deputy Manager )

## 2. SUMMARY OF TEST RESULTS

The EUT has been tested according to the following specifications:

For 802.11b & g, 2412~2462MHz Band

<b>APPLIED STANDARD: FCC Part 15, Subpart C (Section 15.247)</b>			
<b>Standard Section</b>	<b>Test Type and Limit</b>	<b>Result</b>	<b>Remark</b>
15.207	AC Power Conducted Emission	PASS	Meet the requirement of limit. Minimum passing margin is -13.51dB at 3.984MHz
15.247(a)(2)	Spectrum Bandwidth of a Direct Sequence Spread Spectrum System Limit: min. 500kHz	PASS	Meet the requirement of limit.
15.247(b)	Maximum Peak Output Power Limit: max. 30dBm	PASS	Meet the requirement of limit.
15.247(d)	Radiated Emissions Limit: Table 15.209	PASS	Meet the requirement of limit. Minimum passing margin is -0.11dB at 2483.5MHz
15.247(e)	Power Spectral Density Limit: max. 8dBm	PASS	Meet the requirement of limit.
15.247(d)	Conducted Out-Band Emission Measurement Limit: 20dB less than the peak value of fundamental frequency	PASS	Meet the requirement of limit.





A D T

For 802.11a, 5725~5850MHz Band

APPLIED STANDARD: FCC Part 15, Subpart C (Section 15.247)			
Standard Section	Test Type and Limit	Result	Remark
15.207	AC Power Conducted Emission	PASS	Meet the requirement of limit. Minimum passing margin is -13.53dB at 3.980MHz
15.247(a)(2)	Spectrum Bandwidth of a Direct Sequence Spread Spectrum System Limit: min. 500kHz	PASS	Meet the requirement of limit.
15.247(b)	Maximum Peak Output Power Limit: max. 30dBm	PASS	Meet the requirement of limit.
15.247(d)	Radiated Emissions Limit: Table 15.209	PASS	Meet the requirement of limit. Minimum passing margin is -0.59 at 11490.00
15.247(e)	Power Spectral Density Limit: max. 8dBm	PASS	Meet the requirement of limit.
15.247(d)	Conducted Out-Band Emission Measurement Limit: 20dB less than the peak value of fundamental frequency	PASS	Meet the requirement of limit.

**NOTE:**

1. The EUT was operating in 2400 ~ 2483.5MHz, 5.15~5.25GHz and 5.725~5.850GHz frequencies band. This report was recorded the RF parameters including 2400 ~ 2483.5MHz and 5.725~5.850GHz. For the 5.15~5.25GHz RF parameters was recorded in another test report.



A D T

## 2.1 MEASUREMENT UNCERTAINTY

Where relevant, the following measurement uncertainty levels have been estimated for tests performed on the EUT as specified in CISPR 16-4-2:

This uncertainty represents an expanded uncertainty expressed at approximately the 95% confidence level using a coverage factor of  $k=2$ .

Measurement	Value
Conducted emissions	2.44 dB
Radiated emissions (30MHz-1GHz)	3.94 dB
Radiated emissions (1GHz -18GHz)	2.49 dB
Radiated emissions (18GHz -40GHz)	2.70 dB



A D T

### 3. GENERAL INFORMATION

#### 3.1 GENERAL DESCRIPTION OF EUT

<b>PRODUCT</b>	11n Access-Point
<b>MODEL NO.</b>	AP-7131N
<b>FCC ID</b>	UZ7AP7131N
<b>POWER SUPPLY</b>	DC 48V from Power Adapter or DC 55V from POE
<b>MODULATION TYPE</b>	CCK, DQPSK, DBPSK for DSSS 64QAM, 16QAM, QPSK, BPSK for OFDM
<b>MODULATION TECHNOLOGY</b>	DSSS, OFDM
<b>TRANSFER RATE</b>	802.11b: 11 / 5.5 / 2 / 1Mbps 802.11g: 54 / 48 / 36 / 24 / 18 / 12 / 9 / 6Mbps 802.11a: 54 / 48 / 36 / 24 / 18 / 12 / 9 / 6Mbps Draft 802.11n (20MHz) (400ns GI): 144.4 / 130 / 115.6 / 86.7 / 72.2 / 65 / 57.8 / 43.3 / 28.9 / 21.7 / 14.4 / 7.2Mbps Draft 802.11n (40MHz) (400ns GI): 300 / 270 / 240 / 180 / 150 / 135 / 120 / 90 / 60 / 45 / 30 / 15Mbps Draft 802.11n (20MHz) (800ns GI): 130 / 117 / 104 / 78 / 65 / 58.5 / 52 / 39 / 26 / 19.5 / 13 / 6.5Mbps. Draft 802.11n (40MHz) (400ns GI): 270 / 243 / 216 / 162 / 135 / 121.5 / 108 / 81 / 54 / 40.5 / 27 / 13.5Mbps.
<b>FREQUENCY RANGE</b>	For 15.407 802.11a: 5.18 ~ 5.24GHz For 15.247 802.11b & 802.11g: 2412 ~ 2462MHz 802.11a: 5.745 ~ 5.825GHz
<b>NUMBER OF CHANNEL</b>	<b>For 15.407</b> 4 for 802.11a, draft 802.11n (20MHz) 2 for draft 802.11n (40MHz) <b>For 15.247(2.4GHz)</b> 11 for 802.11b, 802.11g, draft 802.11n (20MHz) 7 for draft 802.11n (40MHz) <b>For 15.247(5GHz)</b> 5 for 802.11a, draft 802.11n (20MHz) 2 for draft 802.11n (40MHz)



A D T

<b>MAXIMUM OUTPUT POWER</b>	Please see note 2
<b>ANTENNA TYPE</b>	Please see note 1
<b>DATA CABLE</b>	NA
<b>I/O PORTS</b>	RJ-45 port * 1 < Ethernet (10,100,1000Mbps) > RJ-45 port * 1 < POE / Ethernet (10,100, 1000Mbps) > RJ-45 port * 1 < Console >
<b>ASSOCIATED DEVICES</b>	Adapter x1 ; POE x1

**NOTE:**

1. There are twelve antennas provided to this EUT, please refer to the following table:

No	Brand	Model	Antenna Type	Connector Type (External only)	Frequency range (MHz)	Indoor or Outdoor
1	Symbol	ML-2499-BYGA2-01R	YAGI	Type N-Female	2400~2500	Indoor
2	Symbol	ML-2499-11PNA2-01R	Panel	RP-BNC-Female	2400~2500	Indoor
3	Symbol	ML-2452-APA2-01	Dipole	RP-SMA MALE	2400-2500, 5150-5850	Indoor
4	Motolora	ML-2452-PTA2M3X3-1	Embedded	RP-SMA-Male	2400-2500, 4900-5990	Indoor
5	Symbol	ML-5299-WPNA1-01R	Panel	RP-SMA-Female	5150-5875	Indoor
6	Symbol	ML-2499-HPA3-01R	Dipole	RP-BNC FEMALE	2400-2500	Indoor
7	Symbol	ML-5299-HPA1-01R	Dipole	RP-SMA FEMALE	5150-5875	Indoor
8	Motolora	ML-2452-PTA3M3-036	Patch	RP-SMA-Male	2400-2500, 4900-5990	Indoor
9	WHA YU	ML-2452-APA6J-01	Dipole	SMA Plug Reverse	2400-2500, 4900-5990	Indoor
10	Motolora	ML-2452-PNL9M3-036	Panel	Reverse SMA	2400-2500, 5150-5875	Indoor
11	Motolora	ML-5299-BYGA15-012	YAGI	Type N Female connector	4900-5800	Indoor
12	WHA YU	M25.90002.S01	Dipole	I-PEX	2400-2500, 5150-5850	Indoor
No	Brand	Model	Gain (dBi)	Cable Loss(dB) (External only, if any)	Net Gain (dB)	Cable Length (External only, if any)
1	Symbol	ML-2499-BYGA2-01R	14.2	0.3	13.9	12 inch
2	Symbol	ML-2499-11PNA2-01R	11.2	2.7	8.5	96 inch
3	Symbol	ML-2452-APA2-01	3 / 4	N/A	3 / 4	N/A
4	Motolora	ML-2452-PTA2M3X3-1	1 / 2	N/A	1 / 2	N/A
5	Symbol	ML-5299-WPNA1-01R	14.2	1.2	13	36 inch



A D T

6	Symbol	ML-2499-HPA3-01R	4.6	1.3	3.3	48 inch
7	Symbol	ML-5299-HPA1-01R	5.9	0.84	5.06	36 inch
8	Motolora	ML-2452-PTA3M3-036	6/7	0.92 / 1.97	5.08 / 5.03	36 inch
9	WHA YU	ML-2452-APA6J-01	-6 / -6	N/A	2.4GHz Peak gain : -5.76dBi 5GHz Peak gain : band 1: -3.77dBi band 2: -3.38dBi band 3: -2.84dBi band 4: -2.94dBi	N/A
10	Motolora	ML-2452-PNL9M3-036	8 / 10.7	N/A	8 / 10.7	36 inch
11	Motolora	ML-5299-BYGA15-012	14.5	N/A	14.5	3 ft
12	WHA YU	M25.90002.S01	3.03 / 4.06	N/A	3.03 / 4.06	63mm

**Note :**

1. For Radio card 1: The antennas 1~4, 6 & 8-10 will be use, therefore antenna 1, 2, 4, 6, 8, were chosen for final test.
2. For Radio card 2: The antennas 3~5 & 7-11 will be use, therefore antenna 4, 5, 7, 8, 11, were chosen for final test.
3. For Radio card 3: The antenna 12 will be use only, therefore antenna 12 was chosen for final test.



A D T

2. The maximum output power (Unit : mW) :

No.	Model No.	Operating Frequency (MHz)			
		2412MHz ~ 2462MHz			
		802.11b	802.11g	draft 802.11n (20MHz)	draft 802.11n (40MHz)
1	ML-2499-BYGA2-01R	108.863	139.609	149.939	126.103
2	ML-2499-11PNA2-01R	308.169	324.163	289.148	233.642
4	ML-2452-PTA2M3X3-1	538.069	996.802	986.682	999.385
6	ML-2499-HPA3-01R	956.375	903.749	943.888	646.982
8	ML-2452-PTA3M3-036	509.155	801.957	718.918	519.772
12	M25.90002.S01	283.792	NA	NA	NA
No.	Model No.	Operating Frequency (MHz)			
		5180 ~ 5240 MHz			
		802.11a	draft 802.11n (20MHz)	draft 802.11n (40MHz)	
4	ML-2452-PTA2M3X3-1	30.990	30.606	46.138	
5	ML-5299-WPNA1-01R	6.148	6.993	9.274	
7	ML-5299-HPA1-01R	30.990	30.606	46.138	
8	ML-2452-PTA3M3-036	30.990	30.606	46.138	
11	ML-5299-BYGA15-012	4.600	4.559	6.660	
12	M25.90002.S01	9.705	NA	NA	
No.	Model No.	Operating Frequency (MHz)			
		5745 ~ 5825 MHz			
		802.11a	draft 802.11n (20MHz)	draft 802.11n (40MHz)	
4	ML-2452-PTA2M3X3-1	940.387	921.281	898.173	
5	ML-5299-WPNA1-01R	189.619	183.244	178.048	
7	ML-5299-HPA1-01R	940.387	921.281	898.173	
8	ML-2452-PTA3M3-036	940.387	921.281	898.173	
11	ML-5299-BYGA15-012	136.405	135.623	133.889	
12	M25.90002.S01	310.456	NA	NA	

3. The EUT must be supplied with a power adapter or POE as below :

Adapter		
Brand	Model No.	Spec.
MOTOROLA	50-14000-247R	AC Input : 100-240V, 1A, 50-60Hz DC Output : 48V, 0.75A DC output cable : 1.9m, unshielded with one core
POE		
Brand	Model No.	Spec.
MOTOROLA	AP-PSBIAS-1P3-AFR	AC Input : 100-240V, 0.8A, 50 / 60Hz DC Output : 55V, 0.57A

4. The EUT has three radio cards inside the device.  
 Radio 1 operates all the time, with 3Tx MIMO, at 2.4 GHz.  
 Radio 2 operates all the time, with 3Tx MIMO at 5 GHz.  
 Radio 3 does not operate in 11n mode. In the 2.4GHz band, the radio 3 only transmits at 1Mbps which is 802.11b DSSS rate. In the 5GHz band, the radio 3 only transmits in 6Mbps which is 802.11a OFDM rate.
5. During normal operation, only radio 1 and 2 will transmit data, radio 3 will work as a sensor radio. Radio 3 is mostly Rx-only, though it does also transmit a low duty cycle signal at 2.4 GHz and 5 GHz. The radio 1 or radio 2 will transmit simultaneously with radio 3 when radio 3 detects signals.
6. Radio 1 and radio 2 will reduce 1dB automatically from maximum power when radio 3 detect signals and transmit signals.
7. The EUT incorporates CDD function with 802.11a, 802.11b, 802.11g and MIMO function with draft 802.11n.
8. The radio 1 and radio 2 are 3 \* 3 spatial MIMO (3Tx & 3Rx) without beam forming function. The antenna configurations are three transmitter antennas and three receiver antennas. Spatial multiplexing modes for simultaneous transmission using 3 antennas, and for simultaneous receiver using 3 antennas.
9. The EUT have MIMO power save mode, one transmitter may be active (chain 0) while others is inactive (chain 1 and chain 2) or two transmitters may be active (chain 0 and 1) while others is inactive (chain 2). Output power is no different compared to operation when all of transmitter chains are active. Transmitter power is not increased or decreased for chain 0 or chain 0 and chain 1 when is single chain or dual chain mode, compared to three chain active mode.
10. The above EUT information was declared by manufacturer and for more detailed features description, please refer to the manufacturer's specifications or user's manual.



### 3.2 DESCRIPTION OF TEST MODES

#### Operated in 2400 ~ 2483.5MHz band:

Eleven channels are provided for 802.11b, 802.11g, draft 802.11n (20MHz):

CHANNEL	FREQUENCY	CHANNEL	FREQUENCY
1	2412MHz	7	2442MHz
2	2417MHz	8	2447MHz
3	2422MHz	9	2452MHz
4	2427MHz	10	2457MHz
5	2432MHz	11	2462MHz
6	2437MHz		

Seven channels are provided for draft 802.11n (40MHz):

CHANNEL	FREQUENCY	CHANNEL	FREQUENCY
1	2422MHz	5	2442MHz
2	2427MHz	6	2447MHz
3	2432MHz	7	2452MHz
4	2437MHz		

#### Operated in 5725 ~ 5850MHz band:

Five channels are provided for 802.11a, draft 802.11n (20MHz):

CHANNEL	FREQUENCY	CHANNEL	FREQUENCY
1	5745 MHz	4	5805 MHz
2	5765 MHz	5	5825 MHz
3	5785 MHz		

Two channels are provided for draft 802.11n (40MHz):

CHANNEL	FREQUENCY
1	5755 MHz
2	5795 MHz





A D T

### 3.2.1 TEST MODE APPLICABILITY AND TESTED CHANNEL DETAIL:

EUT CONFIGURE MODE	APPLICABLE TO				DESCRIPTION
	PLC	RE < 1G	RE ≥ 1G	APCM	
-	√	√	√	√	-

Where PLC: Power Line Conducted Emission

RE < 1G: Radiated Emission below 1GHz

RE ≥ 1G: Radiated Emission above 1GHz

APCM: Antenna Port Conducted Measurement

### ANTENNA COMBINATION MODE:

COMBINATION MODE	OPERATION MODE	TX CHAIN(0)	TX CHAIN(1)	TX CHAIN(2)
A	802.11 a	√		
B	802.11 a	√		√
C	802.11 a	√	√	√
D	802.11 b	√		
E	802.11 b	√		√
F	802.11 b	√	√	√
G	802.11 g	√		
H	802.11 g	√		√
I	802.11 g	√	√	√
J	DRAFT 802.11n(20MHz) for MCS0~7	√		
K	DRAFT 802.11n(20MHz) for MCS0~7	√		√
L	DRAFT 802.11n(20MHz) for MCS0~7	√	√	√
M	DRAFT 802.11n(20MHz) for MCS8~15	√		
N	DRAFT 802.11n(20MHz) for MCS8~15	√		√
O	DRAFT 802.11n(20MHz) for MCS8~15	√	√	√
P	DRAFT 802.11n(40MHz) for MCS0~7	√		
Q	DRAFT 802.11n(40MHz) for MCS0~7	√		√
R	DRAFT 802.11n(40MHz) for MCS0~7	√	√	√
S	DRAFT 802.11n(40MHz) for MCS8~15	√		
T	DRAFT 802.11n(40MHz) for MCS8~15	√		√
U	DRAFT 802.11n(40MHz) for MCS8~15	√	√	√

Note:

1. The above information was declared by manufacturer and for more detailed features description, please refer to the manufacturer's specifications or user's manual.
2. Mode A, D (Radio card 3) the worst modes, were selected as representative mode for the report.
3. Mode F, I, L, R (Radio card 1) the worst modes, were selected as representative mode for the report.
3. Mode C, L, R (Radio card 2) the worst modes, were selected as representative mode for the report.

**POWER LINE CONDUCTED EMISSION TEST:**

- Pre-Scan has been conducted to determine the worst-case mode from all possible combinations between available modulations, data rates and antenna ports (if EUT with antenna diversity architecture).
- Following channel(s) was (were) selected for the final test as listed below.

MODE	AVAILABLE CHANNEL	TESTED CHANNEL	MODULATION TECHNOLOGY	MODULATION TYPE	DATA RATE (Mbps)	TX COMBINATION
For 2.4 GHz 802.11b	1 to 11	1	DSSS	DBPSK	1	D
For 2.4 GHz 802.11b	1 to 11	1	DSSS	DBPSK	1	F
For 5 GHz 802.11a	1 to 5	5	OFDM	BPSK	6	A
For 5 GHz 802.11a	1 to 5	5	OFDM	BPSK	6	C

- The EUT was Pre-tested as the following test modes:

Test Mode	Description
Mode 1	With Adapter
Mode 2	With POE

Mode 2, the worse case one, was chosen for final test.

**RADIATED EMISSION TEST (BELOW 1 GHz):**

- Pre-Scan has been conducted to determine the worst-case mode from all possible combinations between available modulations, data rates and antenna ports (if EUT with antenna diversity architecture).
- Following channel(s) was (were) selected for the final test as listed below.

MODE	AVAILABLE CHANNEL	TESTED CHANNEL	MODULATION TECHNOLOGY	MODULATION TYPE	DATA RATE (Mbps)	TX COMBINATION
For 2.4 GHz 802.11b	1 to 11	1	DSSS	DBPSK	1	D
For 2.4 GHz 802.11b	1 to 11	1	DSSS	DBPSK	1	F
For 5 GHz 802.11a	1 to 5	5	OFDM	BPSK	6	A
For 5 GHz 802.11a	1 to 5	1	OFDM	BPSK	6	C

- The EUT was Pre-tested as the following test modes:

Test Mode	Description
Mode 1	With Adapter
Mode 2	With POE

Mode 2, the worse case one, was chosen for final test.



A D T

**RADIATED EMISSION TEST (ABOVE 1 GHz):**

- Pre-Scan has been conducted to determine the worst-case mode from all possible combinations between available modulations, data rates and antenna ports (if EUT with antenna diversity architecture).
- Following channel(s) was (were) selected for the final test as listed below.

MODE	AVAILABLE CHANNEL	TESTED CHANNEL	MODULATION TECHNOLOGY	MODULATION TYPE	DATA RATE (Mbps)	TX COMBINATION
802.11b	1 to 11	1, 6, 11	DSSS	DBPSK	1	D
802.11b	1 to 11	1, 6, 11	DSSS	DBPSK	1	F
802.11g	1 to 11	1, 6, 11	OFDM	BPSK	6	I
For 2.4 GHz Draft 802.11n (20MHz)	1 to 11	1, 6, 11	OFDM	BPSK	6.5	L
For 2.4 GHz Draft 802.11n (40MHz)	1 to 7	1, 4, 7	OFDM	BPSK	13.5	R
802.11a	1 to 5	1,3, 5	OFDM	BPSK	6	A
802.11a	1 to 5	1,3, 5	OFDM	BPSK	6	C
For 5 GHz Draft 802.11n (20MHz)	1 to 5	1,3, 5	OFDM	BPSK	6.5	L
For 5 GHz Draft 802.11n (40MHz)	1 to 2	1, 2	OFDM	BPSK	13.5	R



A D T

**CONDUCTED OUT-BAND EMISSION MEASUREMENT:**

- Pre-Scan has been conducted to determine the worst-case mode from all possible combinations between available modulations, data rates and antenna ports (if EUT with antenna diversity architecture).
- Following channel(s) was (were) selected for the final test as listed below.

MODE	AVAILABLE CHANNEL	TESTED CHANNEL	MODULATION TECHNOLOGY	MODULATION TYPE	DATA RATE (Mbps)	TX COMBINATION
802.11b	1 to 11	1, 11	DSSS	DBPSK	1	D
802.11b	1 to 11	1, 11	DSSS	DBPSK	1	F
802.11g	1 to 11	1, 11	OFDM	BPSK	6	I
For 2.4 GHz Draft 802.11n (20MHz)	1 to 11	1, 11	OFDM	BPSK	6.5	L
For 2.4 GHz Draft 802.11n (40MHz)	1 to 7	1, 7	OFDM	BPSK	13.5	R
802.11a	1 to 5	1, 5	OFDM	BPSK	6	A
802.11a	1 to 5	1, 5	OFDM	BPSK	6	C
For 5 GHz Draft 802.11n (20MHz)	1 to 5	1, 5	OFDM	BPSK	6.5	L
For 5 GHz Draft 802.11n (40MHz)	1 to 2	1, 2	OFDM	BPSK	13.5	R



A D T

**ANTENNA PORT CONDUCTED MEASUREMENT:**

- Pre-Scan has been conducted to determine the worst-case mode from all possible combinations between available modulations, data rates and antenna ports (if EUT with antenna diversity architecture).
- Following channel(s) was (were) selected for the final test as listed below.

MODE	AVAILABLE CHANNEL	TESTED CHANNEL	MODULATION TECHNOLOGY	MODULATION TYPE	DATA RATE (Mbps)	TX COMBINATION
802.11b	1 to 11	1, 6, 11	DSSS	DBPSK	1	D
802.11b	1 to 11	1, 6, 11	DSSS	DBPSK	1	F
802.11g	1 to 11	1, 6, 11	OFDM	BPSK	6	I
For 2.4 GHz Draft 802.11n (20MHz)	1 to 11	1, 6, 11	OFDM	BPSK	6.5	L
For 2.4 GHz Draft 802.11n (40MHz)	1 to 7	1, 4, 7	OFDM	BPSK	13.5	R
802.11a	1 to 5	1,3, 5	OFDM	BPSK	6	A
802.11a	1 to 5	1,3, 5	OFDM	BPSK	6	C
For 5 GHz Draft 802.11n (20MHz)	1 to 5	1,3, 5	OFDM	BPSK	6.5	L
For 5 GHz Draft 802.11n (40MHz)	1 to 2	1, 2	OFDM	BPSK	13.5	R



A D T

### 3.3 GENERAL DESCRIPTION OF APPLIED STANDARDS

The EUT is an 11n Access-Point. According to the specifications of the manufacturer, it must comply with the requirements of the following standards:

**FCC Part 15, Subpart C. (15.247)**

**ANSI C63.4-2003**

All test items have been performed and recorded as per the above standards.

**NOTE:** The EUT is also considered as a kind of computer peripheral, because the connection to computer is necessary for typical use. It has been verified to comply with the requirements of FCC Part 15, Subpart B, Class B (DoC). The test report has been issued separately.



A D T

### 3.4 DESCRIPTION OF SUPPORT UNITS

The EUT has been tested as an independent unit together with other necessary accessories or support units. The following support units or accessories were used to form a representative test configuration during the tests.

NO.	PRODUCT	BRAND	MODEL NO.	SERIAL NO.	FCC ID
1	NOTEBOOK COMPUTER	DELL	D531	CN-0XM006-48643-86L-4472	QDS-BRCM1019
2	NOTEBOOK COMPUTER	DELL	PP18L	6976685584	FCC DoC

NO.	SIGNAL CABLE DESCRIPTION OF THE ABOVE SUPPORT UNITS
1	UTP Cable (10m)
2	UTP Cable (10m)

**NOTE:** All power cords of the above support units are non shielded (1.8m).

### 3.5 CONFIGURATION OF SYSTEM UNDER TEST

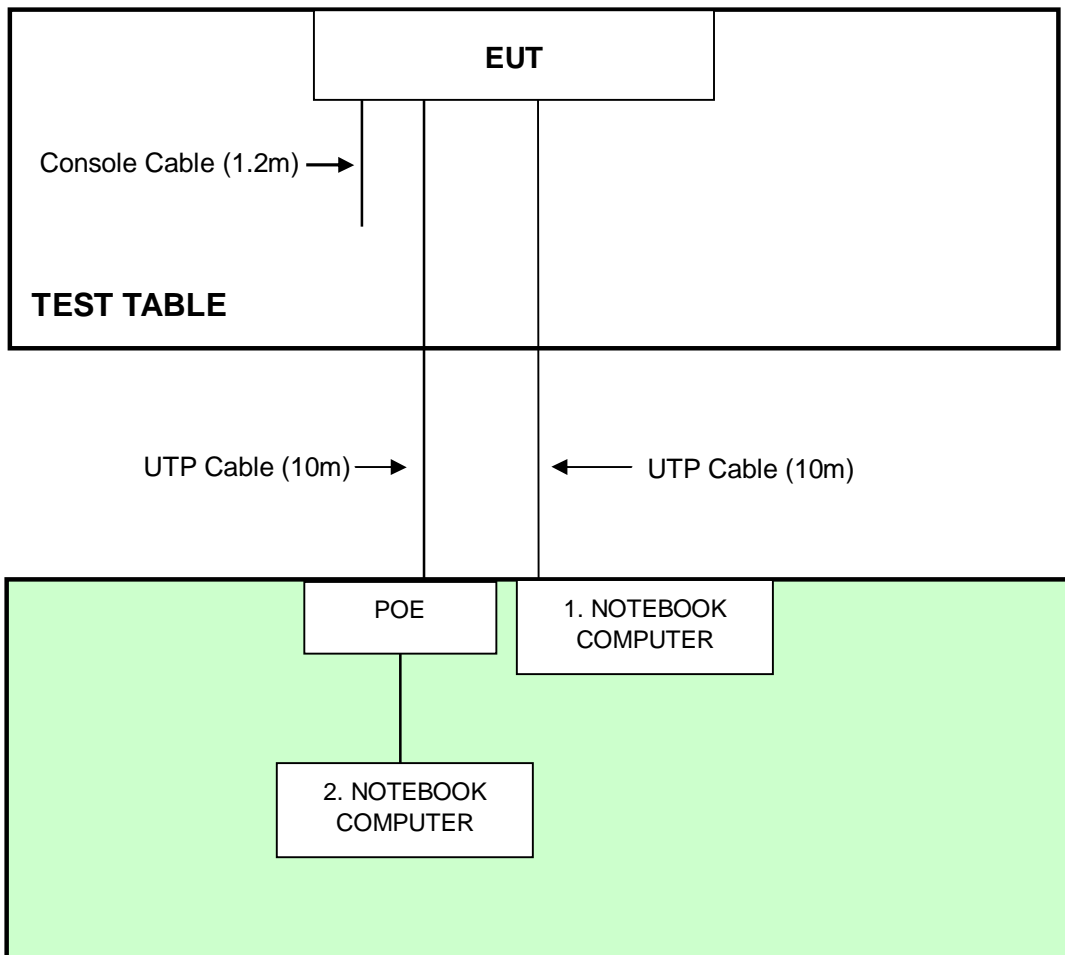





A D T

## 4. TEST TYPES AND RESULTS (802.11b & g, 2400 ~ 2483.5MHz Band)

### 4.1 CONDUCTED EMISSION MEASUREMENT

#### 4.1.1 LIMITS OF CONDUCTED EMISSION MEASUREMENT

FREQUENCY OF EMISSION (MHz)	CONDUCTED LIMIT (dBµV)	
0.15-0.5	Quasi-peak	Average
0.5-5	66 to 56	56 to 46
5-30	56	46
	60	50

- NOTE:**
1. The lower limit shall apply at the transition frequencies.
  2. The limit decreases in line with the logarithm of the frequency in the range of 0.15 to 0.50 MHz.
  3. All emanations from a class A/B digital device or system, including any network of conductors and apparatus connected thereto, shall not exceed the level of field strengths specified above.

#### 4.1.2 TEST INSTRUMENTS

DESCRIPTION & MANUFACTURER	MODEL NO.	SERIAL NO.	CALIBRATED DATE	CALIBRATED UNTIL
Test Receiver	ESCS 30	100375	Mar. 23, 2009	Mar. 22, 2010
Line-Impedance Stabilization Network(for Peripheral)	ENV-216	100071	Nov. 26, 2008	Nov. 25, 2009
Line-Impedance Stabilization Network (for EUT)	ESH3-Z5	848773/004	Nov. 05, 2008	Nov. 04, 2009
RF Cable (JYEBAO)	5DFB	COBCAB-001	Aug. 15, 2008	Aug. 14, 2009
50 ohms Terminator	50	3	Nov. 05, 2008	Nov. 04, 2009
Software	BV ADT_Cond_V7. 3.7	NA	NA	NA

**Note:**

1. The calibration interval of the above test instruments is 12 months and the calibrations are traceable to NML/ROC and NIST/USA.
2. The test was performed in Shielded Room No. B.
- 3 The VCCI Con B Registration No. is C-2193.

#### 4.1.3 TEST PROCEDURES

- a. The EUT was placed 0.4 meters from the conducting wall of the shielded room with EUT being connected to the power mains through a line impedance stabilization network (LISN). Other support units were connected to the power mains through another LISN. The two LISNs provide 50 ohm/ 50uH of coupling impedance for the measuring instrument.
- b. Both lines of the power mains connected to the EUT were checked for maximum conducted interference.
- c. The frequency range from 150kHz to 30MHz was searched. Emission levels under (Limit - 20dB) were not recorded.

#### 4.1.4 DEVIATION FROM TEST STANDARD

No deviation

#### 4.1.5 TEST SETUP

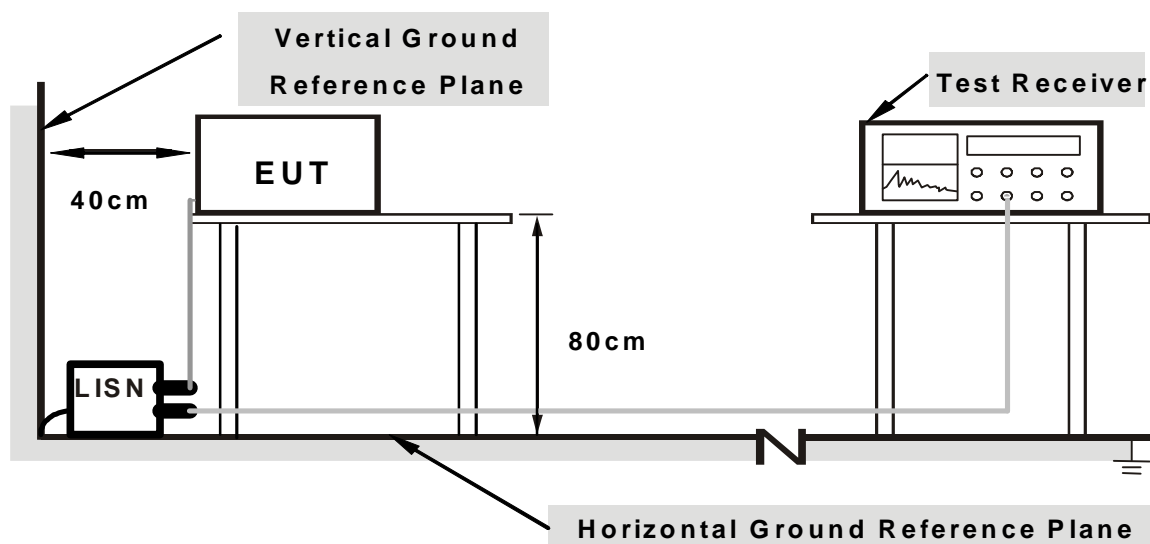

**Note: 1. Support units were connected to second LISN.**

**2. Both of LISNs (AMN) are 80 cm from EUT and at least 80 from other units and other metal planes**

For the actual test configuration, please refer to the related item – Photographs of the Test Configuration.

#### 4.1.6 EUT OPERATING CONDITIONS

- a. Placed the EUT on the testing table.
- b. Prepared other computer systems to act as a communication partner and placed them outside of testing area.
- c. The communication partner run test program “AR5088nx MB82” to enable EUT under transmission/receiving condition continuously at specific channel frequency via UTP cables.



A D T

### 4.1.7 TEST RESULTS

#### 802.11b DSSS MODULATION < Radio Card 3>:

EUT TEST CONDITION		MEASUREMENT DETAIL	
CHANNEL	Channel 1	PHASE	Line (L)
MODULATION TYPE	DBPSK	6dB BANDWIDTH	9 kHz
TRANSFER RATE	1Mbps	INPUT POWER	120Vac, 60 Hz
ENVIRONMENTAL CONDITIONS	25deg. C, 60%RH, 965hPa	TESTED BY	Eagle Chen
TEST MODE	Radio Card 3		

No	Freq. [MHz]	Corr. Factor (dB)	Reading Value [dB (uV)]		Emission Level [dB (uV)]		Limit [dB (uV)]		Margin (dB)	
			Q.P.	AV.	Q.P.	AV.	Q.P.	AV.	Q.P.	AV.
1	0.197	0.22	39.25	-	39.47	-	63.74	53.74	-24.27	-
2	2.633	0.46	38.79	-	39.25	-	56.00	46.00	-16.75	-
<b>+3</b>	<b>3.984</b>	<b>0.58</b>	<b>41.91</b>	-	<b>42.49</b>	-	<b>56.00</b>	<b>46.00</b>	<b>-13.51</b>	-
4	4.781	0.60	40.69	-	41.29	-	56.00	46.00	-14.71	-
5	6.105	0.63	44.09	-	44.72	-	60.00	50.00	-15.28	-
6	7.699	0.66	41.38	-	42.04	-	60.00	50.00	-17.96	-

- REMARKS:**
1. Q.P. and AV. are abbreviations of quasi-peak and average individually.
  2. "-": The Quasi-peak reading value also meets average limit and measurement with the average detector is unnecessary.
  3. The emission levels of other frequencies were very low against the limit.
  4. Margin value = Emission level - Limit value
  5. Correction factor = Insertion loss + Cable loss
  6. Emission Level = Correction Factor + Reading Value.

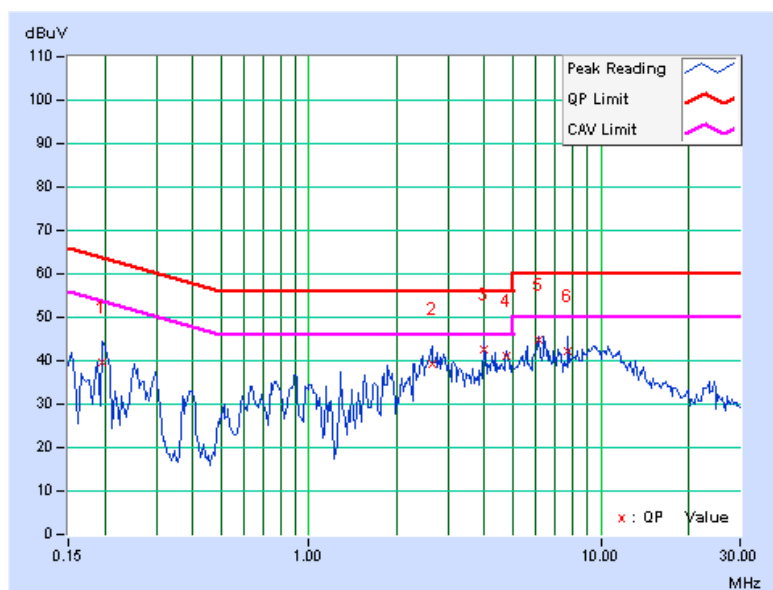



EUT TEST CONDITION		MEASUREMENT DETAIL	
CHANNEL	Channel 1	PHASE	Neutral (N)
MODULATION TYPE	DBPSK	6dB BANDWIDTH	9 kHz
TRANSFER RATE	1Mbps	INPUT POWER	120Vac, 60 Hz
ENVIRONMENTAL CONDITIONS	25deg. C, 60%RH, 965hPa	TESTED BY	Eagle Chen
TEST MODE	Radio Card 3		

No	Freq. [MHz]	Corr. Factor (dB)	Reading Value [dB (uV)]		Emission Level [dB (uV)]		Limit [dB (uV)]		Margin (dB)	
			Q.P.	AV.	Q.P.	AV.	Q.P.	AV.	Q.P.	AV.
1	0.197	0.15	35.45	-	35.60	-	63.74	53.74	-28.14	-
2	2.707	0.39	37.97	-	38.36	-	56.00	46.00	-17.64	-
+3	3.980	0.51	41.08	-	41.59	-	56.00	46.00	-14.41	-
4	4.781	0.52	40.31	-	40.83	-	56.00	46.00	-15.17	-
5	6.109	0.53	42.66	-	43.19	-	60.00	50.00	-16.81	-
6	8.883	0.56	36.90	-	37.46	-	60.00	50.00	-22.54	-

- REMARKS:**
1. Q.P. and AV. are abbreviations of quasi-peak and average individually.
  2. "-": The Quasi-peak reading value also meets average limit and measurement with the average detector is unnecessary.
  3. The emission levels of other frequencies were very low against the limit.
  4. Margin value = Emission level - Limit value
  5. Correction factor = Insertion loss + Cable loss
  6. Emission Level = Correction Factor + Reading Value.

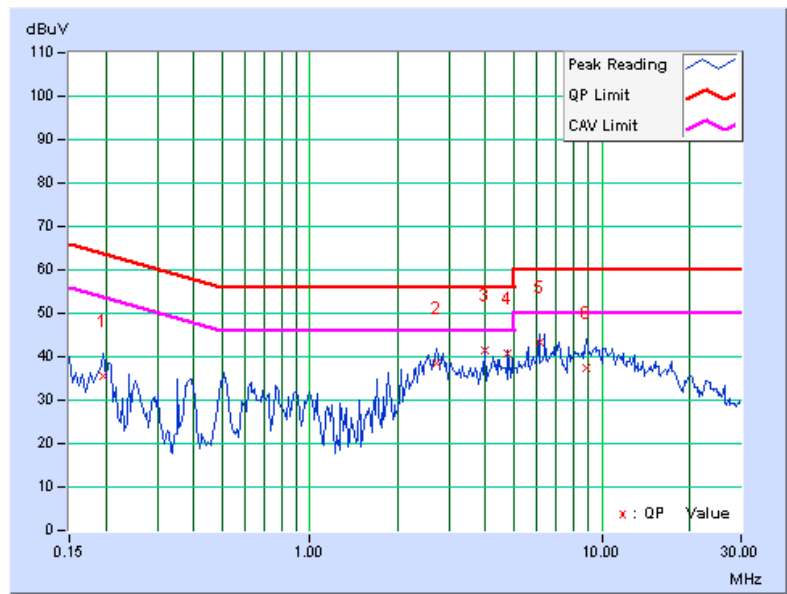

802.11b DSSS MODULATION < Radio Card 1>:

EUT TEST CONDITION		MEASUREMENT DETAIL	
CHANNEL	Channel 1	PHASE	Line (L)
MODULATION TYPE	DBPSK	6dB BANDWIDTH	9 kHz
TRANSFER RATE	1Mbps	INPUT POWER	120Vac, 60 Hz
ENVIRONMENTAL CONDITIONS	25deg. C, 60%RH, 965hPa	TESTED BY	Eagle Chen
TEST MODE	Radio Card 1		

No	Freq. [MHz]	Corr. Factor (dB)	Reading Value [dB (uV)]		Emission Level [dB (uV)]		Limit [dB (uV)]		Margin (dB)	
			Q.P.	AV.	Q.P.	AV.	Q.P.	AV.	Q.P.	AV.
1	0.197	0.22	39.55	-	39.77	-	63.74	53.74	-23.97	-
2	2.746	0.47	39.14	-	39.61	-	56.00	46.00	-16.39	-
3	4.250	0.59	40.39	-	40.98	-	56.00	46.00	-15.02	-
+4	4.777	0.60	40.99	-	41.59	-	56.00	46.00	-14.41	-
5	6.105	0.63	43.42	-	44.05	-	60.00	50.00	-15.95	-
6	8.840	0.68	37.35	-	38.03	-	60.00	50.00	-21.97	-

- REMARKS:**
1. Q.P. and AV. are abbreviations of quasi-peak and average individually.
  2. "-": The Quasi-peak reading value also meets average limit and measurement with the average detector is unnecessary.
  3. The emission levels of other frequencies were very low against the limit.
  4. Margin value = Emission level - Limit value
  5. Correction factor = Insertion loss + Cable loss
  6. Emission Level = Correction Factor + Reading Value.

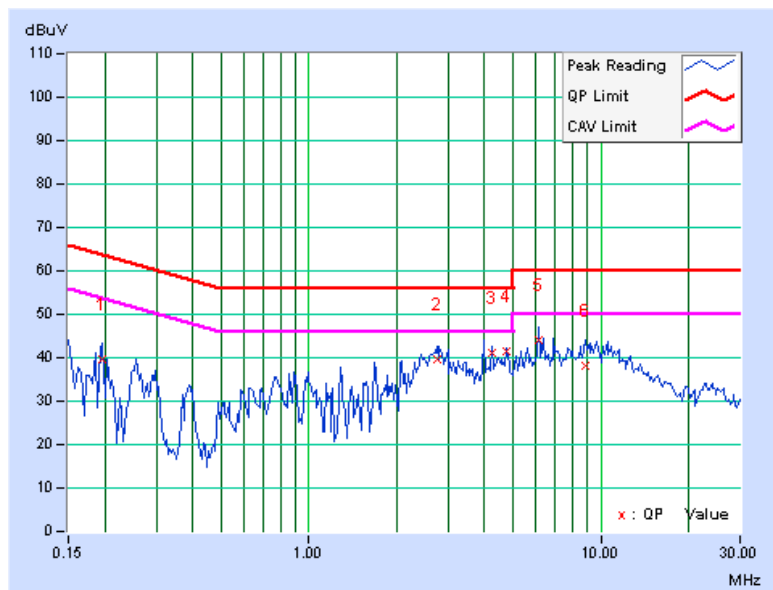



A D T

EUT TEST CONDITION		MEASUREMENT DETAIL	
CHANNEL	Channel 1	PHASE	Neutral (N)
MODULATION TYPE	DBPSK	6dB BANDWIDTH	9 kHz
TRANSFER RATE	1Mbps	INPUT POWER	120Vac, 60 Hz
ENVIRONMENTAL CONDITIONS	25deg. C, 60%RH, 965hPa	TESTED BY	Eagle Chen
TEST MODE	Radio Card 1		

No	Freq. [MHz]	Corr. Factor (dB)	Reading Value [dB (uV)]		Emission Level [dB (uV)]		Limit [dB (uV)]		Margin (dB)	
			Q.P.	AV.	Q.P.	AV.	Q.P.	AV.	Q.P.	AV.
1	0.201	0.15	35.37	-	35.52	-	63.58	53.58	-28.06	-
2	2.766	0.40	38.04	-	38.44	-	56.00	46.00	-17.56	-
+3	3.980	0.51	41.93	-	42.44	-	56.00	46.00	-13.56	-
4	4.777	0.52	40.35	-	40.87	-	56.00	46.00	-15.13	-
5	6.105	0.53	43.08	-	43.61	-	60.00	50.00	-16.39	-
6	6.902	0.54	42.46	-	43.00	-	60.00	50.00	-17.00	-

- REMARKS:**
1. Q.P. and AV. are abbreviations of quasi-peak and average individually.
  2. "-": The Quasi-peak reading value also meets average limit and measurement with the average detector is unnecessary.
  3. The emission levels of other frequencies were very low against the limit.
  4. Margin value = Emission level - Limit value
  5. Correction factor = Insertion loss + Cable loss
  6. Emission Level = Correction Factor + Reading Value.

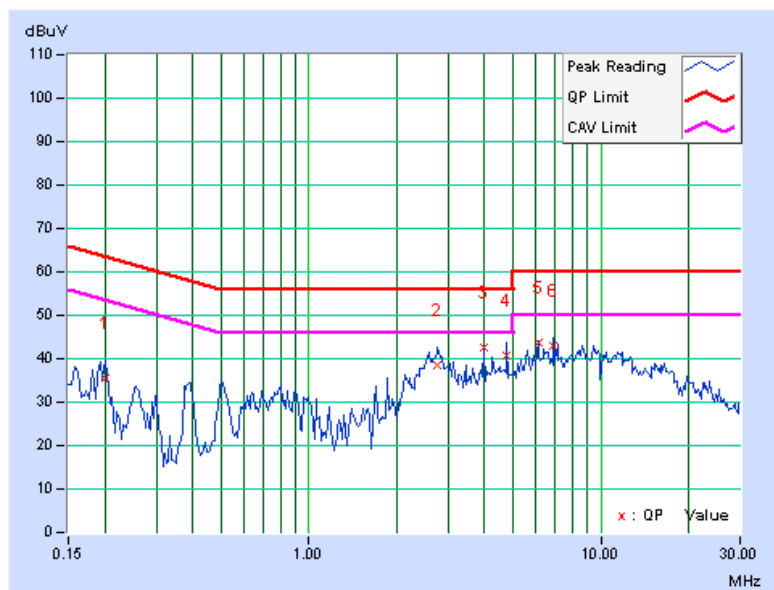

## 4.2 RADIATED EMISSION MEASUREMENT

### 4.2.1 LIMITS OF RADIATED EMISSION MEASUREMENT

Emissions radiated outside of the specified bands, shall be according to the general radiated limits in 15.209 as following:

Frequencies (MHz)	Field strength (microvolts/meter)	Measurement distance (meters)
0.009-0.490	2400/F(kHz)	300
0.490-1.705	24000/F(kHz)	30
1.705-30.0	30	30
30-88	100	3
88-216	150	3
216-960	200	3
Above 960	500	3

**NOTE:**

1. The lower limit shall apply at the transition frequencies.
2. Emission level (dBuV/m) = 20 log Emission level (uV/m).
3. As shown in 15.35(b), for frequencies above 1000MHz, the field strength limits are based on average detector, however, the peak field strength of any emission shall not exceed the maximum permitted average limits, specified above by more than 20dB under any condition of modulation.





A D T

#### 4.2.2 TEST INSTRUMENTS

DESCRIPTION & MANUFACTURER	MODEL NO.	SERIAL NO.	CALIBRATED DATE	CALIBRATED UNTIL
ROHDE & SCHWARZ Spectrum Analyzer	FSP40	100036	Dec. 9, 2008	Dec. 8, 2009
HP Pre_Amplifier	8449B	3008A01923	Nov. 10, 2008	Nov. 9, 2009
ROHDE & SCHWARZ Test Receiver	ESCS30	847124/029	Sep. 9, 2008	Sep. 8, 2009
SCHWARZBECK TRILOG Broadband Antenna	VULB 9168	138	April 29, 2009	April 28, 2010
Schwarzbeck Horn_Antenna	BBHA9120	D124	Dec. 09, 2008	Dec. 08, 2009
Schwarzbeck Horn_Antenna	BBHA 9170	BBHA9170153	Jan. 22, 2009	Jan. 21, 2010
RF Switches	EMH-011	08009	Oct. 07, 2008	Oct. 06, 2009
RF CABLE (Chaintek)	Sucoflex 106	28077	Aug. 15, 2008	Aug. 14, 2009
RF Cable	8DFB	STCCAB-30M-1GHz	Oct. 07, 2008	Oct. 06, 2009
Software	ADT_Radiated_V7.6.15.9.2	NA	NA	NA
CT Antenna Tower & Turn Table	NA	NA	NA	NA

Note: 1. The calibration interval of the above test instruments is 12 months and the calibrations are traceable to NML/ROC and NIST/USA.

2. The horn antenna, HP preamplifier (model: 8449B) and Spectrum Analyzer (model: FSP40) are used only for the measurement of emission frequency above 1GHz if tested.

3. The test was performed in Open Site No. C.

4. The FCC Site Registration No. is 656396.

5. The VCCI Site Registration No. is R-1626.

6. The CANADA Site Registration No. is IC 7450G-3.

#### 4.2.3 TEST PROCEDURES

- a. The EUT was placed on the top of a rotating table 0.8 meters above the ground at a 10 meter open area test site. The table was rotated 360 degrees to determine the position of the highest radiation.
- b. The EUT was set 3 meters away from the interference-receiving antenna, which was mounted on the top of a variable-height antenna tower.
- c. The antenna is a broadband antenna, and its height is varied from one meter to four meters above the ground to determine the maximum value of the field strength. Both horizontal and vertical polarizations of the antenna are set to make the measurement.
- d. For each suspected emission, the EUT was arranged to its worst case and then the antenna was tuned to heights from 1 meter to 4 meters and the rotatable table was turned from 0 degrees to 360 degrees to find the maximum reading.
- e. The test-receiver system was set to Peak Detect Function and Specified Bandwidth with Maximum Hold Mode.
- f. If the emission level of the EUT in peak mode was 10dB lower than the limit specified, then testing could be stopped and the peak values of the EUT would be reported. Otherwise the emissions that did not have 10dB margin would be re-tested one by one using peak, quasi-peak or average method as specified and then reported in a data sheet.

**NOTE:**

1. The resolution bandwidth and video bandwidth of test receiver/spectrum analyzer is 120kHz for Peak detection (PK) and Quasi-peak detection (QP) at frequency below 1GHz.
2. The resolution bandwidth of test receiver/spectrum analyzer is 1 MHz and the video bandwidth is 3 MHz for Peak detection (PK) at frequency above 1GHz.
3. The resolution bandwidth of test receiver/spectrum analyzer is 1 MHz and the video bandwidth is 10 Hz for Average detection (AV) at frequency above 1GHz.

#### 4.2.4 DEVIATION FROM TEST STANDARD

No deviation

#### 4.2.5 TEST SETUP

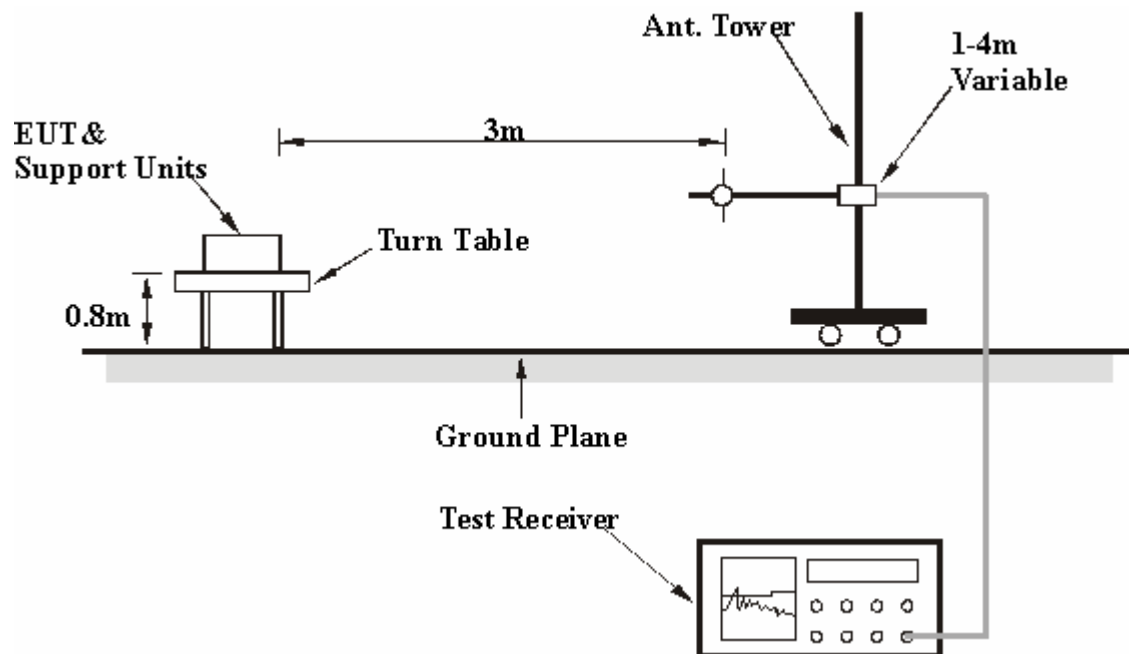

For the actual test configuration, please refer to the related item – Photographs of the Test Configuration.

#### 4.2.6 EUT OPERATING CONDITIONS

Same as the 4.1.6



A D T

#### 4.2.7 TEST RESULTS –ANTENNA 1

#### BELOW 1GHz WORST-CASE DATA : 802.11b DSSS MODULATION

EUT TEST CONDITION		MEASUREMENT DETAIL	
CHANNEL	Channel 1	FREQUENCY RANGE	Below 1000MHz
INPUT POWER	120Vac, 60 Hz	DETECTOR FUNCTION	Quasi-Peak
ENVIRONMENTAL CONDITIONS	25.0deg. C, 72.0%RH 965hPa	TESTED BY	Frank Liu

ANTENNA POLARITY & TEST DISTANCE: HORIZONTAL AT 3 M								
NO.	FREQ. (MHz)	EMISSION LEVEL (dBuV/m)	LIMIT (dBuV/m)	MARGIN (dB)	ANTENNA HEIGHT (m)	TABLE ANGLE (Degree)	RAW VALUE (dBuV)	CORRECTION FACTOR (dB/m)
1	125.00	29.67 QP	43.50	-13.83	2.34 H	62	16.61	13.07
2	250.00	42.34 QP	46.00	-3.66	1.01 H	259	28.09	14.25
3	274.00	38.76 QP	46.00	-7.24	1.04 H	44	23.26	15.50
4	375.00	39.73 QP	46.00	-6.27	1.02 H	85	20.92	18.81
5	649.99	42.34 QP	46.00	-3.66	1.04 H	198	16.81	25.53
6	749.99	40.34 QP	46.00	-5.66	1.02 H	111	13.43	26.91
7	999.98	36.09 QP	54.00	-17.91	1.04 H	237	5.35	30.74

ANTENNA POLARITY & TEST DISTANCE: VERTICAL AT 3 M								
NO.	FREQ. (MHz)	EMISSION LEVEL (dBuV/m)	LIMIT (dBuV/m)	MARGIN (dB)	ANTENNA HEIGHT (m)	TABLE ANGLE (Degree)	RAW VALUE (dBuV)	CORRECTION FACTOR (dB/m)
1	44.96	32.73 QP	40.00	-7.27	1.04 V	148	17.94	14.79
2	132.00	27.46 QP	43.50	-16.04	1.12 V	227	13.67	13.79
3	250.00	34.93 QP	46.00	-11.07	1.04 V	86	20.68	14.25
4	650.00	36.43 QP	46.00	-9.57	1.04 V	259	10.90	25.53
5	875.00	35.49 QP	46.00	-10.51	1.12 V	234	6.20	29.29
6	999.98	37.42 QP	54.00	-16.58	1.35 V	122	6.68	30.74

- REMARKS:**
1. Emission level (dBuV/m) = Raw Value (dBuV) + Correction Factor (dB/m).
  2. Correction Factor (dB/m) = Antenna Factor (dB/m) + Cable Factor (dB).
  3. The other emission levels were very low against the limit.
  4. Margin value = Emission level – Limit value.



A D T

ABOVE 1GHz WORST-CASE DATA

802.11b DSSS MODULATION

EUT TEST CONDITION		MEASUREMENT DETAIL	
CHANNEL	Channel 1	FREQUENCY RANGE	1 ~ 25GHz
INPUT POWER	120Vac, 60 Hz	DETECTOR FUNCTION	Peak (PK) Average (AV)
ENVIRONMENTAL CONDITIONS	30.0deg. C, 55.0%RH 965hPa	TESTED BY	Eric Lee

ANTENNA POLARITY & TEST DISTANCE: HORIZONTAL AT 3 M								
NO.	FREQ. (MHz)	EMISSION LEVEL (dBuV/m)	LIMIT (dBuV/m)	MARGIN (dB)	ANTENNA HEIGHT (m)	TABLE ANGLE (Degree)	RAW VALUE (dBuV)	CORRECTION FACTOR (dB/m)
1	2390.00	64.86 PK	74.00	-9.14	1.78 H	96	34.80	30.06
2	2390.00	53.45 AV	54.00	-0.55	1.78 H	96	23.39	30.06
3	*2412.00	123.05 PK			1.77 H	94	92.90	30.15
4	*2412.00	118.07 AV			1.77 H	94	87.92	30.15
5	4824.00	45.96 PK	74.00	-28.04	1.10 H	269	10.50	35.46
6	4824.00	33.45 AV	54.00	-20.55	1.10 H	269	-2.01	35.46
ANTENNA POLARITY & TEST DISTANCE: VERTICAL AT 3 M								
NO.	FREQ. (MHz)	EMISSION LEVEL (dBuV/m)	LIMIT (dBuV/m)	MARGIN (dB)	ANTENNA HEIGHT (m)	TABLE ANGLE (Degree)	RAW VALUE (dBuV)	CORRECTION FACTOR (dB/m)
1	2390.00	54.23 PK	74.00	-19.77	1.32 V	77	24.17	30.06
2	2390.00	43.38 AV	54.00	-10.62	1.32 V	77	13.32	30.06
3	*2412.00	98.46 PK			1.32 V	79	68.31	30.15
4	*2412.00	93.21 AV			1.32 V	79	63.06	30.15
5	4824.00	40.81 PK	74.00	-33.19	1.06 V	1	5.35	35.46
6	4824.00	32.89 AV	54.00	-21.11	1.06 V	1	-2.57	35.46

- REMARKS:**
1. Emission level (dBuV/m) = Raw Value (dBuV) + Correction Factor (dB/m).
  2. Correction Factor (dB/m) = Antenna Factor (dB/m) + Cable Factor (dB).
  3. The other emission levels were very low against the limit.
  4. Margin value = Emission level – Limit value.
  5. “ \* “: Fundamental frequency.



A D T

EUT TEST CONDITION		MEASUREMENT DETAIL	
CHANNEL	Channel 6	FREQUENCY RANGE	1 ~ 25GHz
INPUT POWER	120Vac, 60 Hz	DETECTOR FUNCTION	Peak (PK) Average (AV)
ENVIRONMENTAL CONDITIONS	30.0deg. C, 55.0%RH 965hPa	TESTED BY	Eric Lee

**ANTENNA POLARITY & TEST DISTANCE: HORIZONTAL AT 3 M**

NO.	FREQ. (MHz)	EMISSION LEVEL (dBuV/m)	LIMIT (dBuV/m)	MARGIN (dB)	ANTENNA HEIGHT (m)	TABLE ANGLE (Degree)	RAW VALUE (dBuV)	CORRECTION FACTOR (dB/m)
1	*2437.00	123.70 PK			1.78 H	93	93.46	30.24
2	*2437.00	118.69 AV			1.78 H	93	88.45	30.24
3	4874.00	45.86 PK	74.00	-28.14	1.54 H	24	10.31	35.55
4	4874.00	33.69 AV	54.00	-20.31	1.54 H	24	-1.86	35.55
5	7311.00	53.56 PK	74.00	-20.44	1.14 H	46	11.52	42.04
6	7311.00	39.54 AV	54.00	-14.46	1.14 H	46	-2.50	42.04

**ANTENNA POLARITY & TEST DISTANCE: VERTICAL AT 3 M**

NO.	FREQ. (MHz)	EMISSION LEVEL (dBuV/m)	LIMIT (dBuV/m)	MARGIN (dB)	ANTENNA HEIGHT (m)	TABLE ANGLE (Degree)	RAW VALUE (dBuV)	CORRECTION FACTOR (dB/m)
1	*2437.00	98.61 PK			1.34 V	84	68.37	30.24
2	*2437.00	93.60 AV			1.34 V	84	63.36	30.24
3	4874.00	46.12 PK	74.00	-27.88	1.09 V	28	10.57	35.55
4	4874.00	33.27 AV	54.00	-20.73	1.09 V	28	-2.28	35.55
5	7311.00	53.42 PK	74.00	-20.58	1.40 V	32	11.38	42.04
6	7311.00	39.38 AV	54.00	-14.62	1.40 V	32	-2.66	42.04

- REMARKS:**
1. Emission level (dBuV/m) = Raw Value (dBuV) + Correction Factor (dB/m).
  2. Correction Factor (dB/m) = Antenna Factor (dB/m) + Cable Factor (dB).
  3. The other emission levels were very low against the limit.
  4. Margin value = Emission level – Limit value.
  5. “ \* “: Fundamental frequency.



A D T

EUT TEST CONDITION		MEASUREMENT DETAIL	
CHANNEL	Channel 11	FREQUENCY RANGE	1 ~ 25GHz
INPUT POWER	120Vac, 60 Hz	DETECTOR FUNCTION	Peak (PK) Average (AV)
ENVIRONMENTAL CONDITIONS	30.0deg. C, 55.0%RH 965hPa	TESTED BY	Eric Lee

**ANTENNA POLARITY & TEST DISTANCE: HORIZONTAL AT 3 M**

NO.	FREQ. (MHz)	EMISSION LEVEL (dBuV/m)	LIMIT (dBuV/m)	MARGIN (dB)	ANTENNA HEIGHT (m)	TABLE ANGLE (Degree)	RAW VALUE (dBuV)	CORRECTION FACTOR (dB/m)
1	*2462.00	119.85 PK			1.78 H	96	89.51	30.34
2	*2462.00	117.25 AV			1.78 H	96	86.91	30.34
3	2486.99	66.21 PK	74.00	-7.79	1.75 H	93	35.77	30.44
4	2486.99	53.45 AV	54.00	-0.55	1.75 H	93	23.01	30.44
5	4924.00	46.27 PK	74.00	-27.73	1.10 H	67	10.64	35.63
6	4924.00	33.57 AV	54.00	-20.43	1.10 H	67	-2.06	35.63
7	7386.00	54.73 PK	74.00	-19.27	1.15 H	94	12.50	42.23
8	7386.00	39.67 AV	54.00	-14.33	1.15 H	94	-2.56	42.23

**ANTENNA POLARITY & TEST DISTANCE: VERTICAL AT 3 M**

NO.	FREQ. (MHz)	EMISSION LEVEL (dBuV/m)	LIMIT (dBuV/m)	MARGIN (dB)	ANTENNA HEIGHT (m)	TABLE ANGLE (Degree)	RAW VALUE (dBuV)	CORRECTION FACTOR (dB/m)
1	*2462.00	97.63 PK			1.34 V	100	67.29	30.34
2	*2462.00	92.34 AV			1.34 V	100	62.00	30.34
3	2483.50	55.92 PK	74.00	-18.08	1.00 V	100	25.49	30.43
4	2483.50	44.21 AV	54.00	-9.79	1.00 V	100	13.78	30.43
5	4924.00	45.95 PK	74.00	-28.05	1.06 V	33	10.32	35.63
6	4924.00	33.21 AV	54.00	-20.79	1.06 V	33	-2.42	35.63
7	7386.00	53.67 PK	74.00	-20.33	1.35 V	169	11.44	42.23
8	7386.00	40.27 AV	54.00	-13.73	1.35 V	169	-1.96	42.23

- REMARKS:**
1. Emission level (dBuV/m) = Raw Value (dBuV) + Correction Factor (dB/m).
  2. Correction Factor (dB/m) = Antenna Factor (dB/m) + Cable Factor (dB).
  3. The other emission levels were very low against the limit.
  4. Margin value = Emission level – Limit value.
  5. “ \* “: Fundamental frequency.



A D T

### RESTRICTED BANDEDGE (802.11b MODE,CH1, HORIZONTAL )

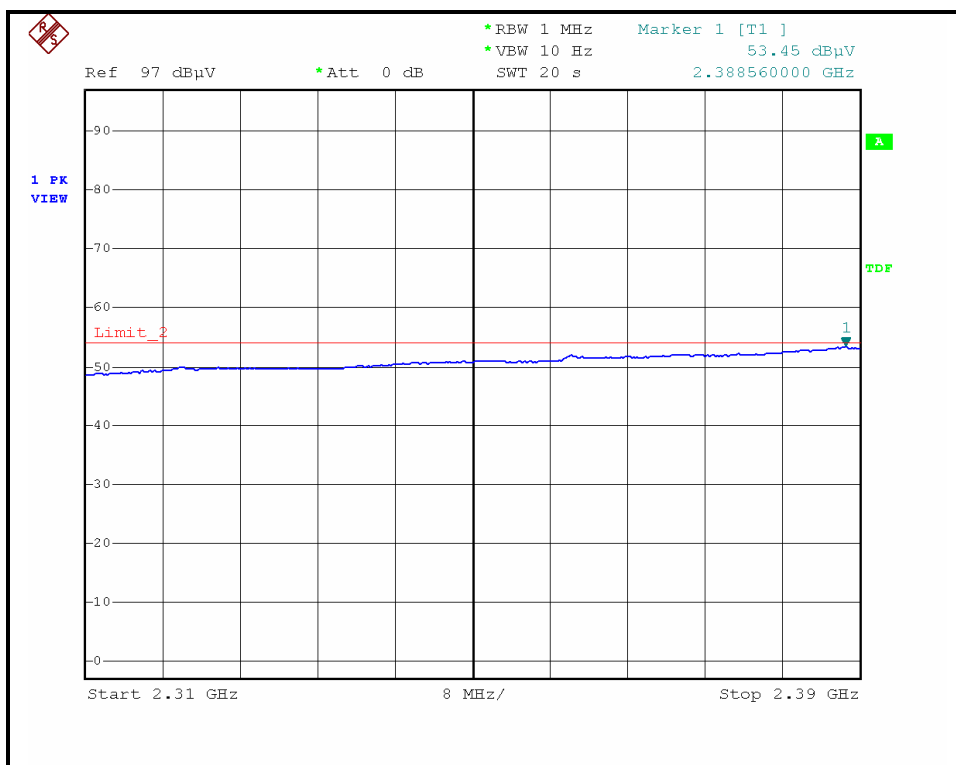
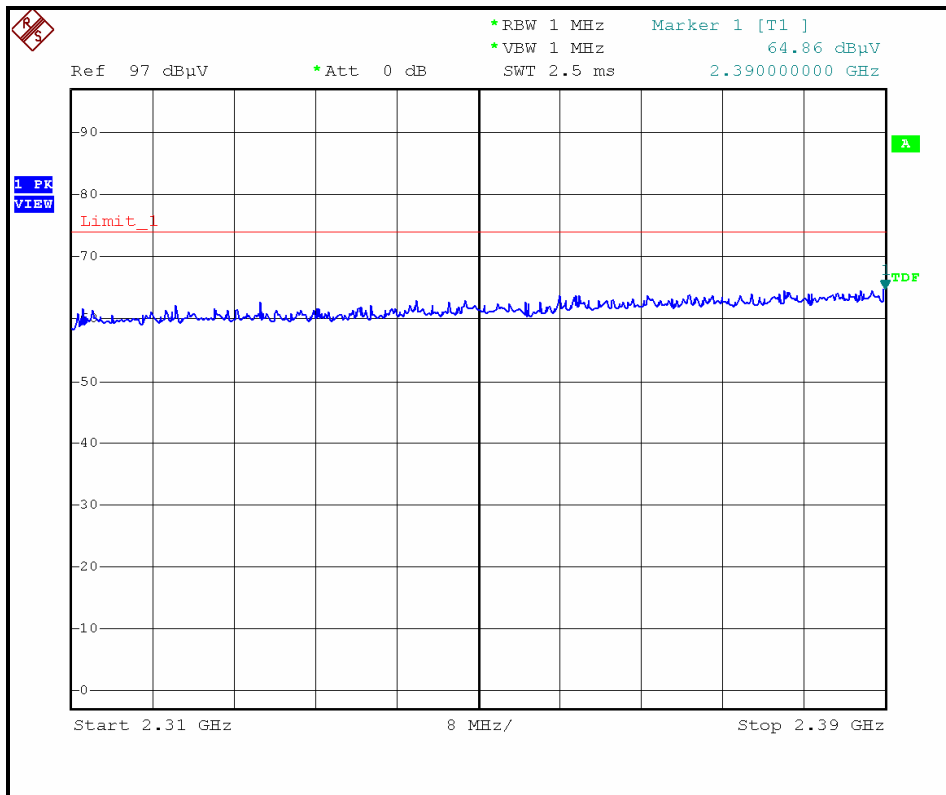





A D T

### RESTRICTED BANDEDGE (802.11b MODE,CH1, VERTICAL )

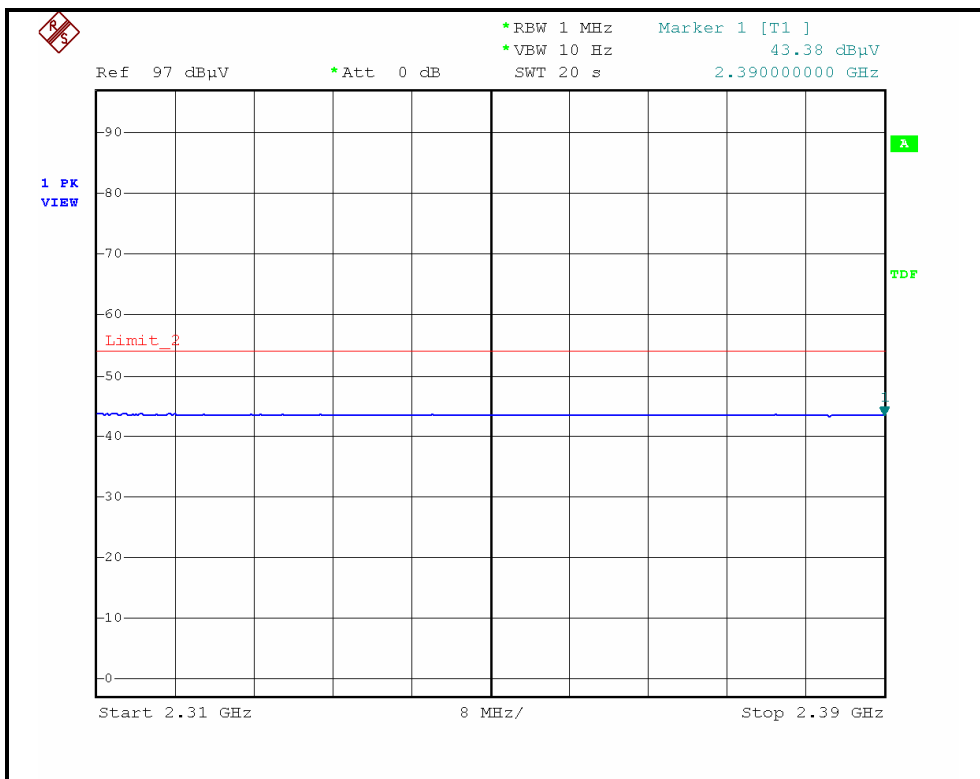
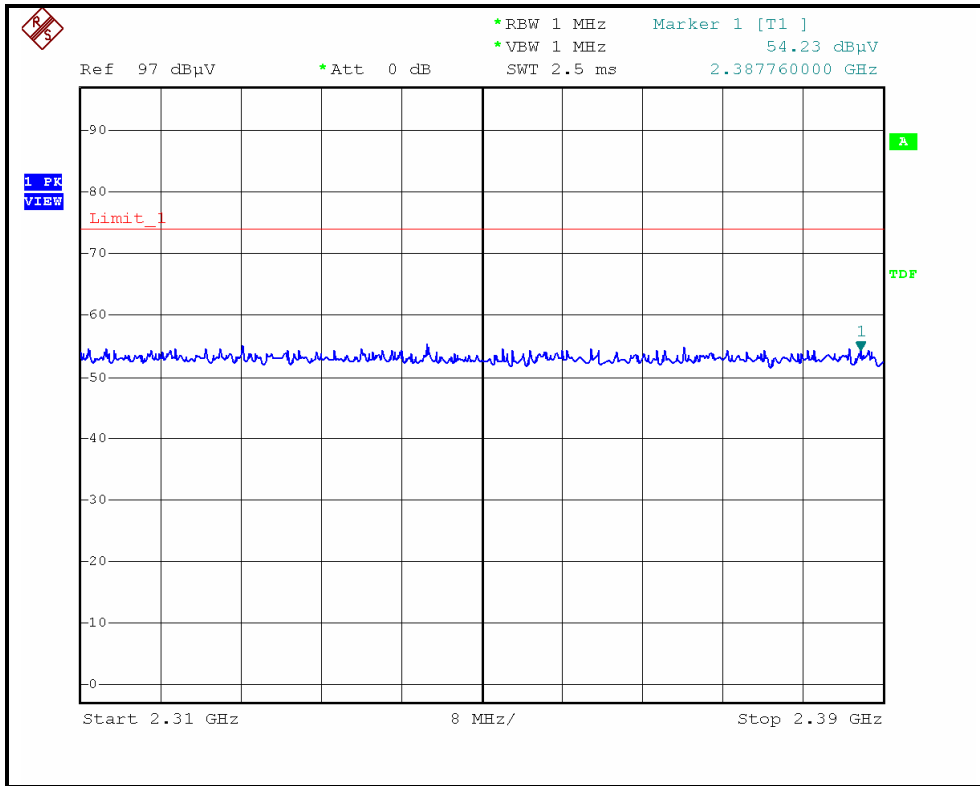



A D T

### RESTRICTED BANDEDGE (802.11b MODE,CH11, HORIZONTAL )

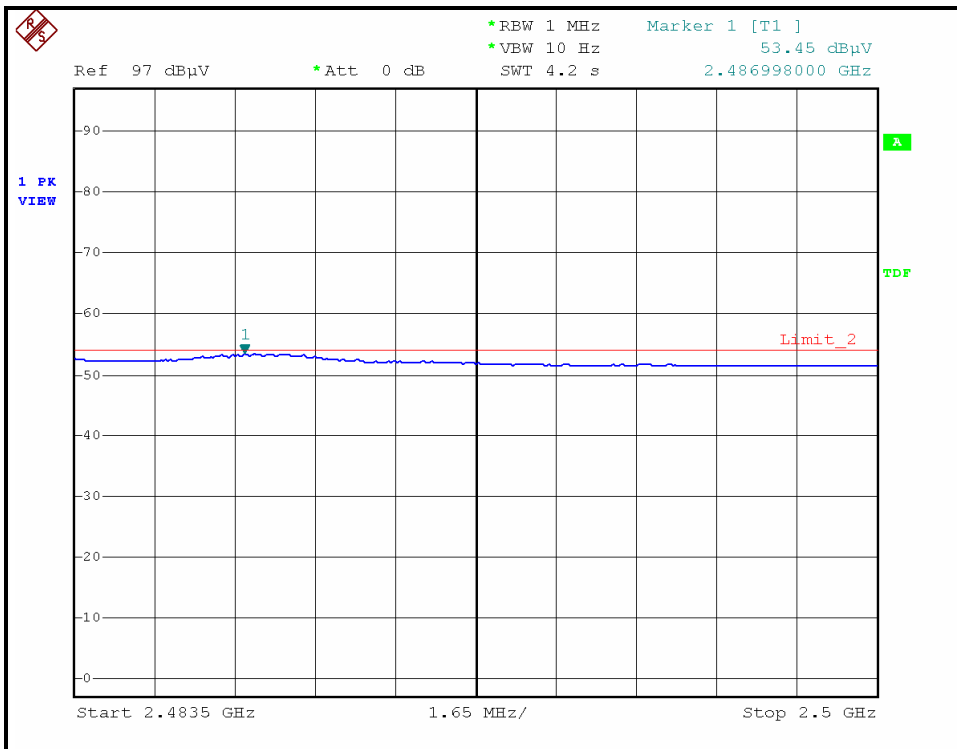
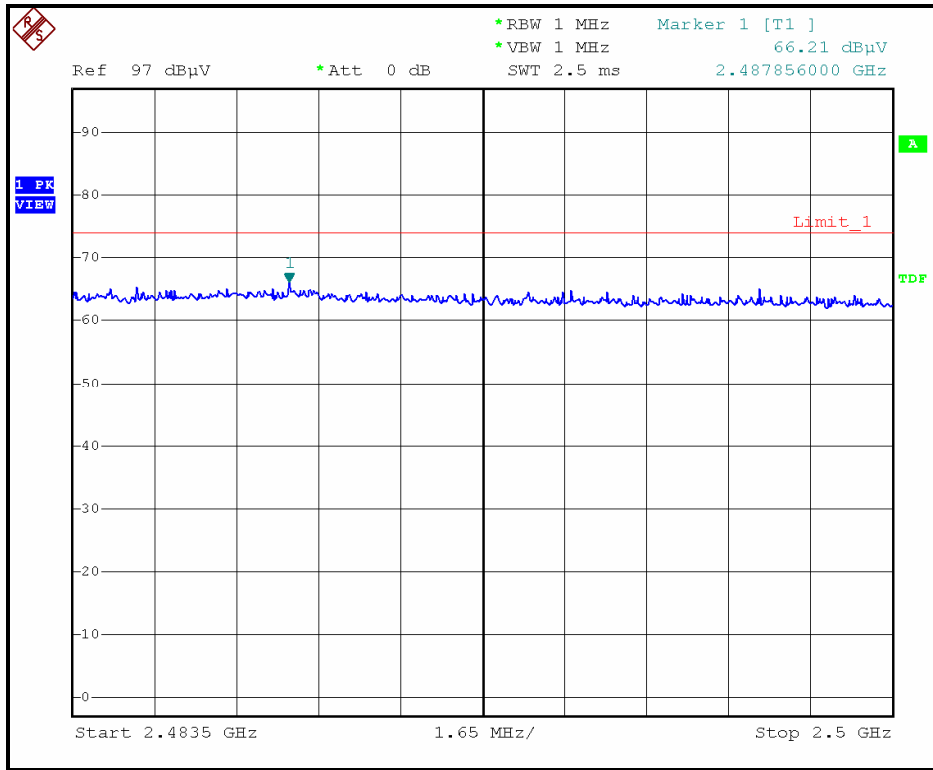



A D T

### RESTRICTED BANDEDGE (802.11b MODE, CH11, VERTICAL )

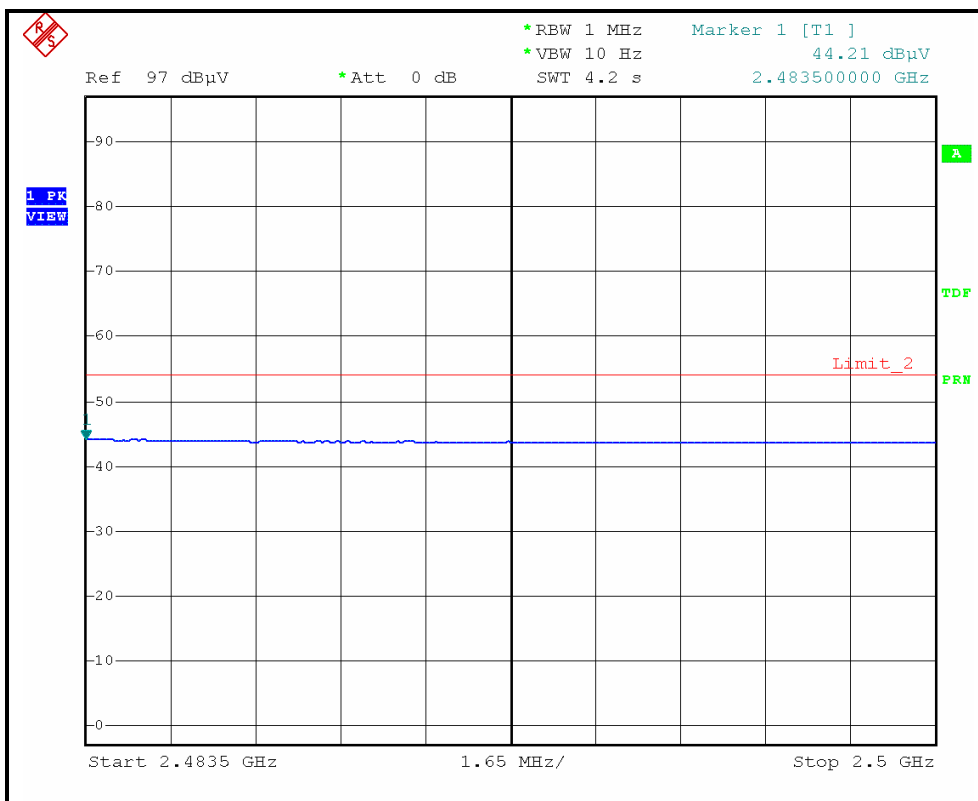
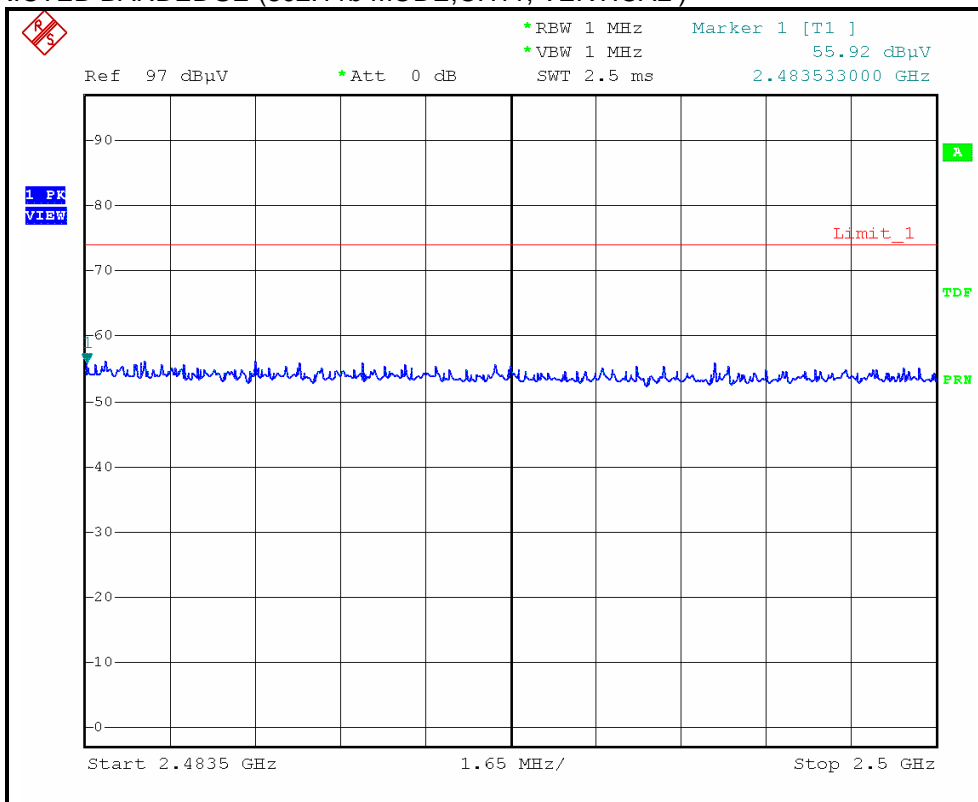



A D T

802.11g OFDM MODULATION

EUT TEST CONDITION		MEASUREMENT DETAIL	
CHANNEL	Channel 1	FREQUENCY RANGE	1 ~ 25GHz
INPUT POWER	120Vac, 60 Hz	DETECTOR FUNCTION	Peak (PK) Average (AV)
ENVIRONMENTAL CONDITIONS	30.0deg. C, 55.0%RH 965hPa	TESTED BY	Eric Lee

ANTENNA POLARITY & TEST DISTANCE: HORIZONTAL AT 3 M								
NO.	FREQ. (MHz)	EMISSION LEVEL (dBuV/m)	LIMIT (dBuV/m)	MARGIN (dB)	ANTENNA HEIGHT (m)	TABLE ANGLE (Degree)	RAW VALUE (dBuV)	CORRECTION FACTOR (dB/m)
1	2390.00	66.56 PK	74.00	-7.44	1.78 H	93	36.50	30.06
2	2390.00	53.41 AV	54.00	-0.59	1.78 H	93	23.35	30.06
3	*2412.00	118.33 PK			1.78 H	99	88.18	30.15
4	*2412.00	106.37 AV			1.78 H	99	76.22	30.15
5	4824.00	44.83 PK	74.00	-29.17	1.09 H	288	9.37	35.46
6	4824.00	33.21 AV	54.00	-20.79	1.09 H	288	-2.25	35.46
ANTENNA POLARITY & TEST DISTANCE: VERTICAL AT 3 M								
NO.	FREQ. (MHz)	EMISSION LEVEL (dBuV/m)	LIMIT (dBuV/m)	MARGIN (dB)	ANTENNA HEIGHT (m)	TABLE ANGLE (Degree)	RAW VALUE (dBuV)	CORRECTION FACTOR (dB/m)
1	2390.00	53.25 PK	74.00	-20.75	1.00 V	83	23.19	30.06
2	2390.00	42.82 AV	54.00	-11.18	1.00 V	83	12.76	30.06
3	*2412.00	97.30 PK			1.00 V	94	67.15	30.15
4	*2412.00	85.90 AV			1.00 V	94	55.75	30.15
5	4824.00	44.53 PK	74.00	-29.47	1.04 V	23	9.07	35.46
6	4824.00	33.10 AV	54.00	-20.90	1.04 V	23	-2.36	35.46

- REMARKS:**
1. Emission level (dBuV/m) = Raw Value (dBuV) + Correction Factor (dB/m).
  2. Correction Factor (dB/m) = Antenna Factor (dB/m) + Cable Factor (dB).
  3. The other emission levels were very low against the limit.
  4. Margin value = Emission level – Limit value.
  5. “ \* “: Fundamental frequency.



A D T

EUT TEST CONDITION		MEASUREMENT DETAIL	
CHANNEL	Channel 6	FREQUENCY RANGE	1 ~ 25GHz
INPUT POWER	120Vac, 60 Hz	DETECTOR FUNCTION	Peak (PK) Average (AV)
ENVIRONMENTAL CONDITIONS	30.0deg. C, 55.0%RH 965hPa	TESTED BY	Eric Lee

**ANTENNA POLARITY & TEST DISTANCE: HORIZONTAL AT 3 M**

NO.	FREQ. (MHz)	EMISSION LEVEL (dBuV/m)	LIMIT (dBuV/m)	MARGIN (dB)	ANTENNA HEIGHT (m)	TABLE ANGLE (Degree)	RAW VALUE (dBuV)	CORRECTION FACTOR (dB/m)
1	2390.00	65.00 PK	74.00	-9.00	1.78 H	98	34.94	30.06
2	2390.00	53.11 AV	54.00	-0.89	1.78 H	98	23.05	30.06
3	*2437.00	119.68 PK			1.76 H	96	89.44	30.24
4	*2437.00	107.41 AV			1.76 H	96	77.17	30.24
5	2483.50	65.48 PK	74.00	-8.52	1.79 H	96	35.05	30.43
6	<b>2483.50</b>	<b>53.89 AV</b>	<b>54.00</b>	<b>-0.11</b>	<b>1.79 H</b>	<b>96</b>	<b>23.46</b>	<b>30.43</b>
7	4874.00	45.48 PK	74.00	-28.52	1.14 H	65	9.93	35.55
8	4874.00	33.67 AV	54.00	-20.33	1.14 H	65	-1.88	35.55
9	7311.00	53.85 PK	74.00	-20.15	1.14 H	65	11.81	42.04
10	7311.00	39.40 AV	54.00	-14.60	1.14 H	65	-2.64	42.04

**ANTENNA POLARITY & TEST DISTANCE: VERTICAL AT 3 M**

NO.	FREQ. (MHz)	EMISSION LEVEL (dBuV/m)	LIMIT (dBuV/m)	MARGIN (dB)	ANTENNA HEIGHT (m)	TABLE ANGLE (Degree)	RAW VALUE (dBuV)	CORRECTION FACTOR (dB/m)
1	*2437.00	97.80 PK			1.00 V	84	67.56	30.24
2	*2437.00	86.30 AV			1.00 V	84	56.06	30.24
3	4874.00	44.58 PK	74.00	-29.42	1.06 V	29	9.03	35.55
4	4874.00	33.54 AV	54.00	-20.46	1.06 V	29	-2.01	35.55
5	7311.00	53.69 PK	74.00	-20.31	1.51 V	72	11.65	42.04
6	7311.00	39.13 AV	54.00	-14.87	1.51 V	72	-2.91	42.04

- REMARKS:**
1. Emission level (dBuV/m) = Raw Value (dBuV) + Correction Factor (dB/m).
  2. Correction Factor (dB/m) = Antenna Factor (dB/m) + Cable Factor (dB).
  3. The other emission levels were very low against the limit.
  4. Margin value = Emission level – Limit value.
  5. “ \* “: Fundamental frequency.



A D T

EUT TEST CONDITION		MEASUREMENT DETAIL	
CHANNEL	Channel 11	FREQUENCY RANGE	1 ~ 25GHz
INPUT POWER	120Vac, 60 Hz	DETECTOR FUNCTION	Peak (PK) Average (AV)
ENVIRONMENTAL CONDITIONS	30.0deg. C, 55.0%RH 965hPa	TESTED BY	Eric Lee

**ANTENNA POLARITY & TEST DISTANCE: HORIZONTAL AT 3 M**

NO.	FREQ. (MHz)	EMISSION LEVEL (dBuV/m)	LIMIT (dBuV/m)	MARGIN (dB)	ANTENNA HEIGHT (m)	TABLE ANGLE (Degree)	RAW VALUE (dBuV)	CORRECTION FACTOR (dB/m)
1	*2462.00	117.59 PK			1.75 H	95	87.25	30.34
2	*2462.00	105.76 AV			1.75 H	95	75.42	30.34
3	2483.50	66.50 PK	74.00	-7.50	1.75 H	94	36.07	30.43
4	2483.50	53.33 AV	54.00	-0.67	1.75 H	94	22.90	30.43
5	4924.00	44.73 PK	74.00	-29.27	1.11 H	295	9.10	35.63
6	4924.00	33.48 AV	54.00	-20.52	1.11 H	295	-2.15	35.63
7	7386.00	54.01 PK	74.00	-19.99	1.15 H	71	11.78	42.23
8	7386.00	39.65 AV	54.00	-14.35	1.15 H	71	-2.58	42.23

**ANTENNA POLARITY & TEST DISTANCE: VERTICAL AT 3 M**

NO.	FREQ. (MHz)	EMISSION LEVEL (dBuV/m)	LIMIT (dBuV/m)	MARGIN (dB)	ANTENNA HEIGHT (m)	TABLE ANGLE (Degree)	RAW VALUE (dBuV)	CORRECTION FACTOR (dB/m)
1	*2462.00	97.00 PK			1.00 V	77	66.66	30.34
2	*2462.00	55.30 AV			1.00 V	77	24.96	30.34
3	2483.50	56.64 PK	74.00	-17.36	1.00 V	104	26.21	30.43
4	2483.50	44.82 AV	54.00	-9.18	1.00 V	104	14.39	30.43
5	4924.00	44.82 PK	74.00	-29.18	1.07 V	33	9.19	35.63
6	4924.00	33.54 AV	54.00	-20.46	1.07 V	33	-2.09	35.63
7	7386.00	53.54 PK	74.00	-20.46	1.54 V	83	11.31	42.23
8	7386.00	39.72 AV	54.00	-14.28	1.54 V	83	-2.51	42.23

- REMARKS:**
1. Emission level (dBuV/m) = Raw Value (dBuV) + Correction Factor (dB/m).
  2. Correction Factor (dB/m) = Antenna Factor (dB/m) + Cable Factor (dB).
  3. The other emission levels were very low against the limit.
  4. Margin value = Emission level – Limit value.
  5. “ \* “: Fundamental frequency.



A D T

### RESTRICTED BANDEDGE (802.11g MODE,CH1, HORIZONTAL )

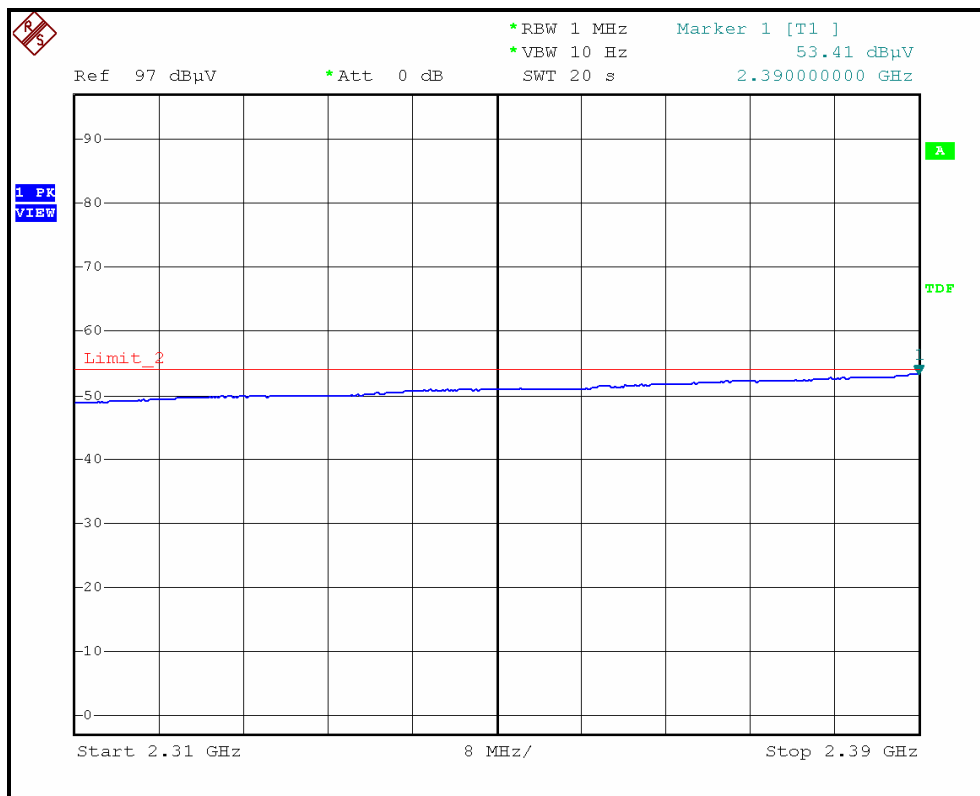
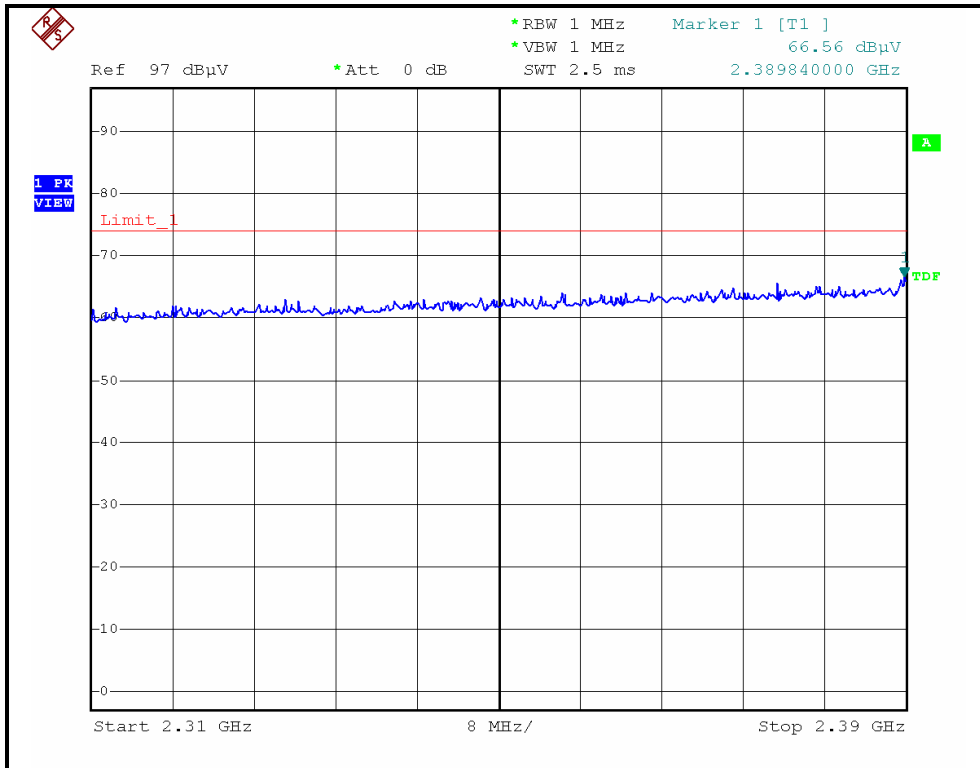



A D T

### RESTRICTED BANDEDGE (802.11g MODE,CH1, VERTICAL )

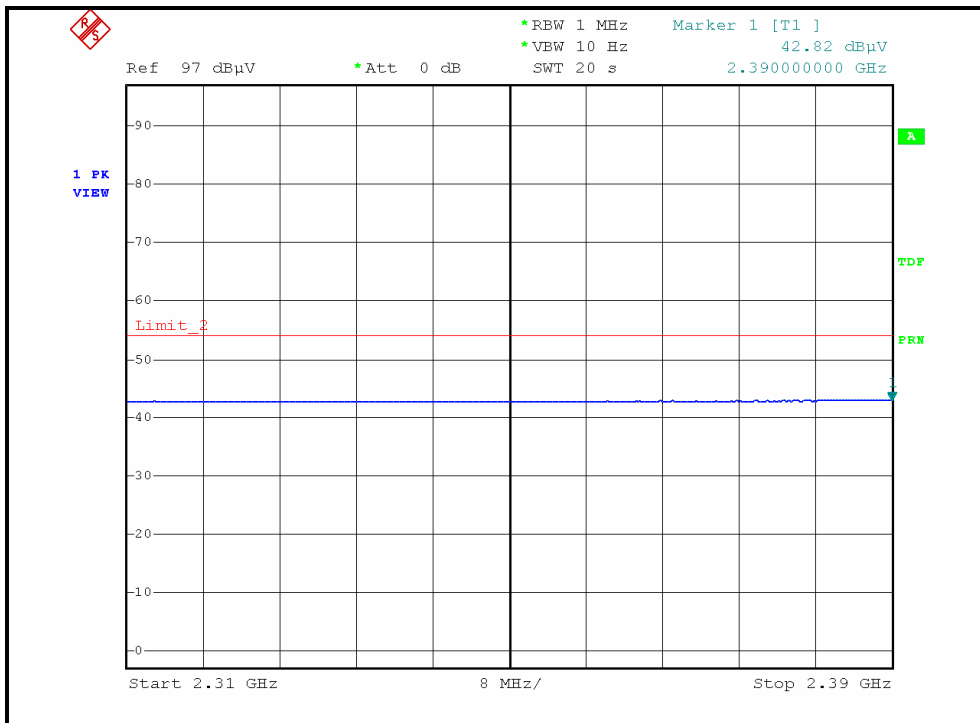
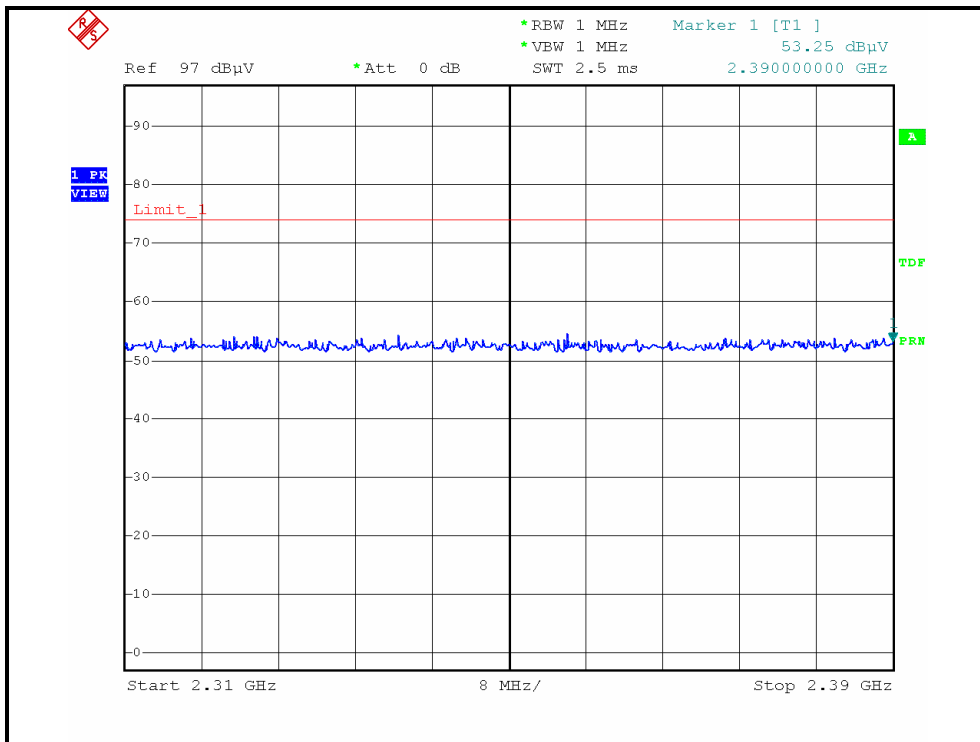





A D T

### RESTRICTED BANDEDGE (802.11g MODE,CH11, HORIZONTAL )

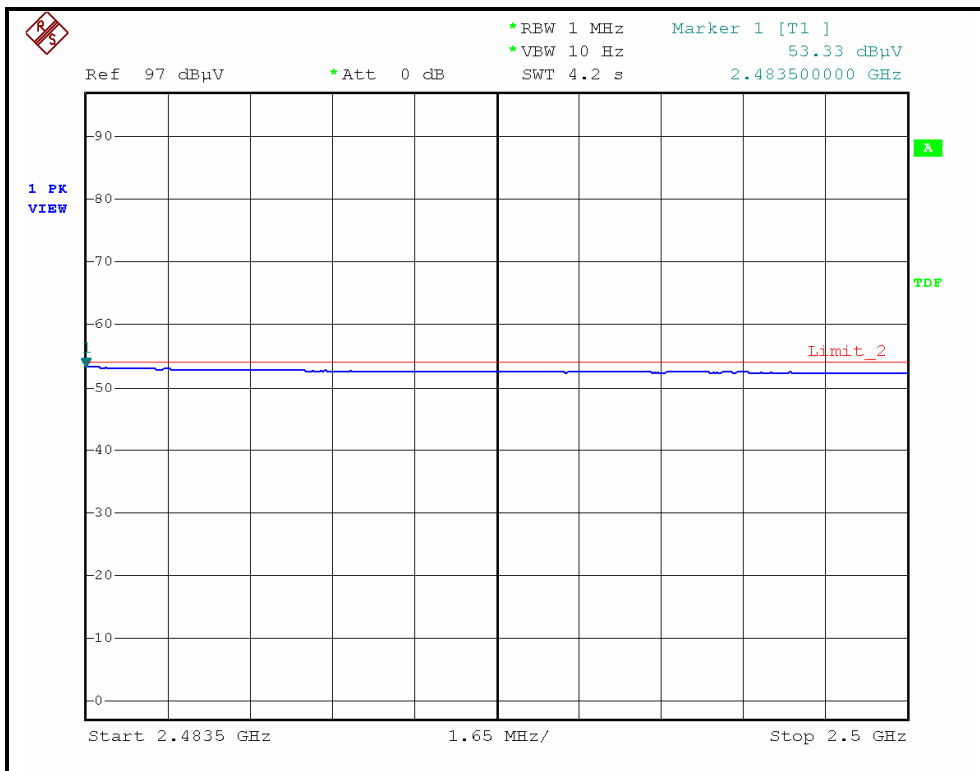
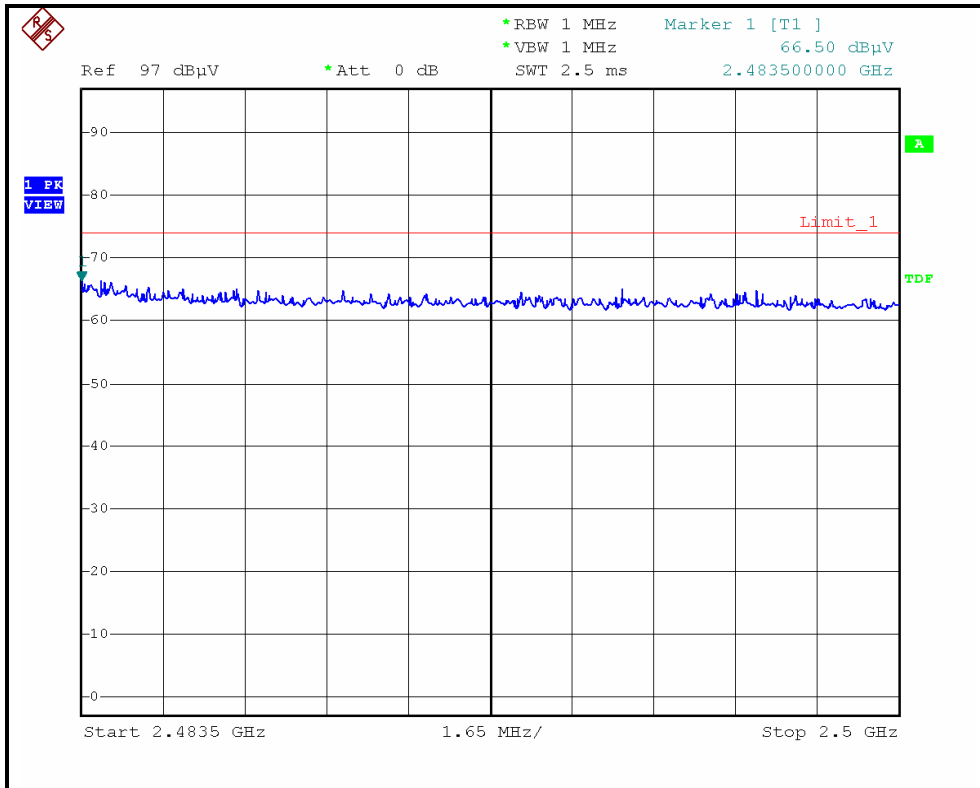



A D T

### RESTRICTED BANDEDGE (802.11g MODE,CH11, VERTICAL )

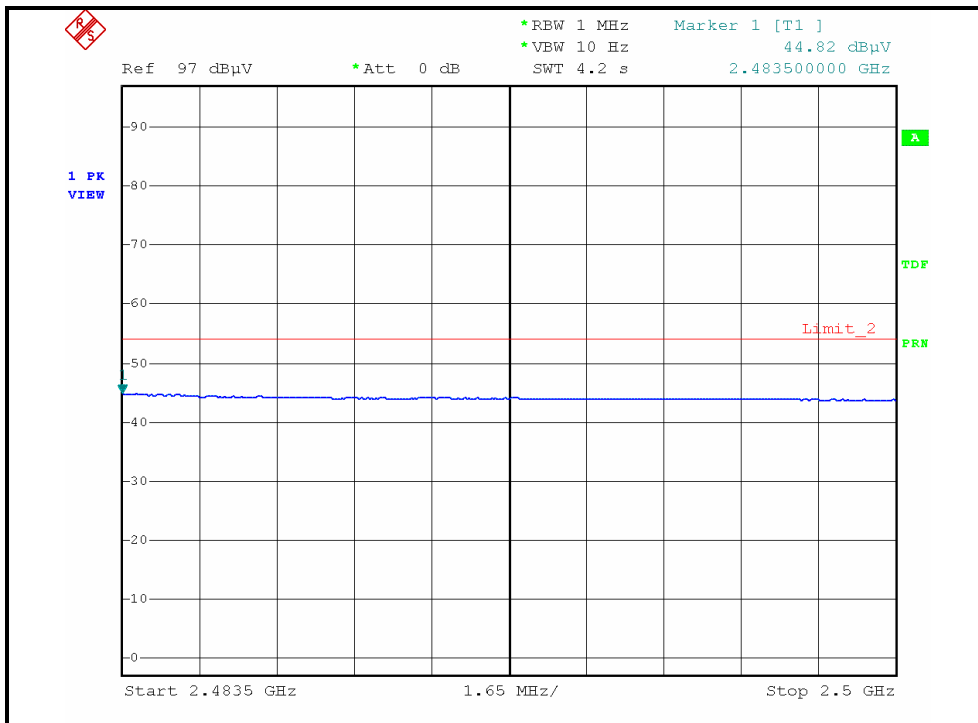
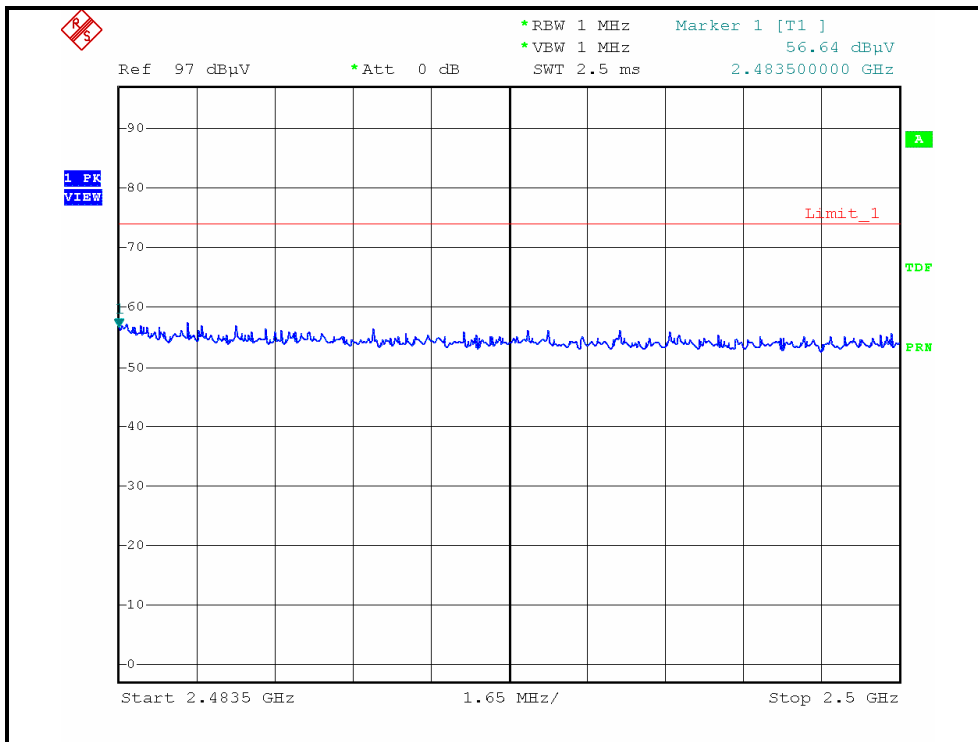



A D T

**DRAFT 802.11n (20MHz) OFDM MODULATION**

EUT TEST CONDITION		MEASUREMENT DETAIL	
CHANNEL	Channel 1	FREQUENCY RANGE	1 ~ 25GHz
INPUT POWER	120Vac, 60 Hz	DETECTOR FUNCTION	Peak (PK) Average (AV)
ENVIRONMENTAL CONDITIONS	30.0deg. C, 55.0%RH 965hPa	TESTED BY	Eric Lee

ANTENNA POLARITY & TEST DISTANCE: HORIZONTAL AT 3 M								
NO.	FREQ. (MHz)	EMISSION LEVEL (dBuV/m)	LIMIT (dBuV/m)	MARGIN (dB)	ANTENNA HEIGHT (m)	TABLE ANGLE (Degree)	RAW VALUE (dBuV)	CORRECTION FACTOR (dB/m)
1	2390.00	66.10 PK	74.00	-7.90	1.78 H	77	36.04	30.06
2	2390.00	53.40 AV	54.00	-0.60	1.78 H	77	23.34	30.06
3	*2412.00	118.50 PK			1.77 H	99	88.35	30.15
4	*2412.00	105.57 AV			1.77 H	99	75.42	30.15
5	4824.00	45.97 PK	74.00	-28.03	1.08 H	287	10.51	35.46
6	4824.00	33.89 AV	54.00	-20.11	1.08 H	287	-1.57	35.46
ANTENNA POLARITY & TEST DISTANCE: VERTICAL AT 3 M								
NO.	FREQ. (MHz)	EMISSION LEVEL (dBuV/m)	LIMIT (dBuV/m)	MARGIN (dB)	ANTENNA HEIGHT (m)	TABLE ANGLE (Degree)	RAW VALUE (dBuV)	CORRECTION FACTOR (dB/m)
1	2390.00	53.12 PK	74.00	-20.88	1.02 V	44	23.06	30.06
2	2390.00	42.70 AV	54.00	-11.30	1.02 V	44	12.64	30.06
3	*2412.00	96.40 PK			1.00 V	82	66.25	30.15
4	*2412.00	81.40 AV			1.00 V	82	51.25	30.15
5	4824.00	45.23 PK	74.00	-28.77	1.09 V	37	9.77	35.46
6	4824.00	33.29 AV	54.00	-20.71	1.09 V	37	-2.17	35.46

- REMARKS:**
1. Emission level (dBuV/m) = Raw Value (dBuV) + Correction Factor (dB/m).
  2. Correction Factor (dB/m) = Antenna Factor (dB/m) + Cable Factor (dB).
  3. The other emission levels were very low against the limit.
  4. Margin value = Emission level – Limit value.
  5. “ \* “: Fundamental frequency.



A D T

EUT TEST CONDITION		MEASUREMENT DETAIL	
CHANNEL	Channel 6	FREQUENCY RANGE	1 ~ 25GHz
INPUT POWER	120Vac, 60 Hz	DETECTOR FUNCTION	Peak (PK) Average (AV)
ENVIRONMENTAL CONDITIONS	30.0deg. C, 55.0%RH 965hPa	TESTED BY	Eric Lee

**ANTENNA POLARITY & TEST DISTANCE: HORIZONTAL AT 3 M**

NO.	FREQ. (MHz)	EMISSION LEVEL (dBuV/m)	LIMIT (dBuV/m)	MARGIN (dB)	ANTENNA HEIGHT (m)	TABLE ANGLE (Degree)	RAW VALUE (dBuV)	CORRECTION FACTOR (dB/m)
1	2390.00	66.18 PK	74.00	-7.82	1.78 H	94	36.12	30.06
2	2390.00	53.20 AV	54.00	-0.80	1.78 H	94	23.14	30.06
3	*2437.00	120.58 PK			1.80 H	96	90.34	30.24
4	*2437.00	107.89 AV			1.80 H	96	77.65	30.24
5	2483.50	65.27 PK	74.00	-8.73	1.80 H	99	34.84	30.43
6	2483.50	52.97 AV	54.00	-1.03	1.80 H	99	22.54	30.43
7	4874.00	46.25 PK	74.00	-27.75	1.11 H	291	10.70	35.55
8	4874.00	33.71 AV	54.00	-20.29	1.11 H	291	-1.84	35.55
9	7311.00	54.78 PK	74.00	-19.22	1.25 H	36	12.74	42.04
10	7311.00	39.28 AV	54.00	-14.72	1.25 H	36	-2.76	42.04

**ANTENNA POLARITY & TEST DISTANCE: VERTICAL AT 3 M**

NO.	FREQ. (MHz)	EMISSION LEVEL (dBuV/m)	LIMIT (dBuV/m)	MARGIN (dB)	ANTENNA HEIGHT (m)	TABLE ANGLE (Degree)	RAW VALUE (dBuV)	CORRECTION FACTOR (dB/m)
1	*2437.00	97.30 PK			1.01 V	74	67.06	30.24
2	*2437.00	86.40 AV			1.01 V	74	56.16	30.24
3	4874.00	45.24 PK	74.00	-28.76	1.44 V	57	9.69	35.55
4	4874.00	36.59 AV	54.00	-17.41	1.44 V	57	1.04	35.55
5	7311.00	66.20 PK	74.00	-7.80	1.24 V	28	24.16	42.04
6	7311.00	53.16 AV	54.00	-0.84	1.24 V	28	11.12	42.04

- REMARKS:**
1. Emission level (dBuV/m) = Raw Value (dBuV) + Correction Factor (dB/m).
  2. Correction Factor (dB/m) = Antenna Factor (dB/m) + Cable Factor (dB).
  3. The other emission levels were very low against the limit.
  4. Margin value = Emission level – Limit value.
  5. “ \* “: Fundamental frequency.



A D T

EUT TEST CONDITION		MEASUREMENT DETAIL	
CHANNEL	Channel 11	FREQUENCY RANGE	1 ~ 25GHz
INPUT POWER	120Vac, 60 Hz	DETECTOR FUNCTION	Peak (PK) Average (AV)
ENVIRONMENTAL CONDITIONS	30.0deg. C, 55.0%RH 965hPa	TESTED BY	Eric Lee

**ANTENNA POLARITY & TEST DISTANCE: HORIZONTAL AT 3 M**

NO.	FREQ. (MHz)	EMISSION LEVEL (dBuV/m)	LIMIT (dBuV/m)	MARGIN (dB)	ANTENNA HEIGHT (m)	TABLE ANGLE (Degree)	RAW VALUE (dBuV)	CORRECTION FACTOR (dB/m)
1	*2462.00	115.92 PK			1.79 H	98	85.58	30.34
2	*2462.00	104.76 AV			1.79 H	98	74.42	30.34
3	2483.50	67.43 PK	74.00	-6.57	1.71 H	95	37.00	30.43
4	2483.50	53.49 AV	54.00	-0.51	1.71 H	95	23.06	30.43
5	4924.00	46.03 PK	74.00	-27.97	1.12 H	299	10.40	35.63
6	4924.00	33.99 AV	54.00	-20.01	1.12 H	299	-1.64	35.63
7	7386.00	54.65 PK	74.00	-19.35	1.30 H	88	12.42	42.23
8	7386.00	39.97 AV	54.00	-14.03	1.30 H	88	-2.26	42.23

**ANTENNA POLARITY & TEST DISTANCE: VERTICAL AT 3 M**

NO.	FREQ. (MHz)	EMISSION LEVEL (dBuV/m)	LIMIT (dBuV/m)	MARGIN (dB)	ANTENNA HEIGHT (m)	TABLE ANGLE (Degree)	RAW VALUE (dBuV)	CORRECTION FACTOR (dB/m)
1	*2462.00	96.10 PK			1.06 V	98	65.76	30.34
2	*2462.00	85.40 AV			1.06 V	98	55.06	30.34
3	2483.50	54.03 PK	74.00	-19.97	1.00 V	84	23.60	30.43
4	2483.50	43.17 AV	54.00	-10.83	1.00 V	84	12.74	30.43
5	4924.00	45.53 PK	74.00	-28.47	1.06 V	55	9.90	35.63
6	4924.00	33.24 AV	54.00	-20.76	1.06 V	55	-2.39	35.63
7	7386.00	54.37 PK	74.00	-19.63	1.23 V	57	12.14	42.23
8	7386.00	39.34 AV	54.00	-14.66	1.23 V	57	-2.89	42.23

- REMARKS:**
1. Emission level (dBuV/m) = Raw Value (dBuV) + Correction Factor (dB/m).
  2. Correction Factor (dB/m) = Antenna Factor (dB/m) + Cable Factor (dB).
  3. The other emission levels were very low against the limit.
  4. Margin value = Emission level – Limit value.
  5. “ \* “: Fundamental frequency.



A D T

### RESTRICTED BANDEDGE (DRAFT 802.11n (20MHz) MODE, CH1, HORIZONTAL )

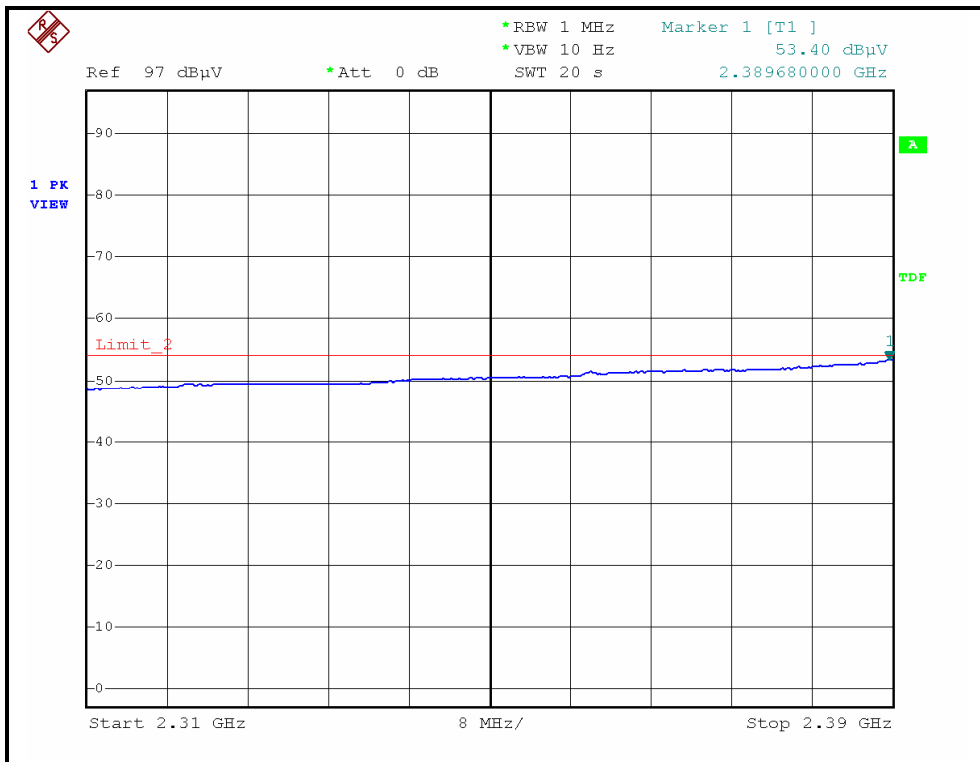
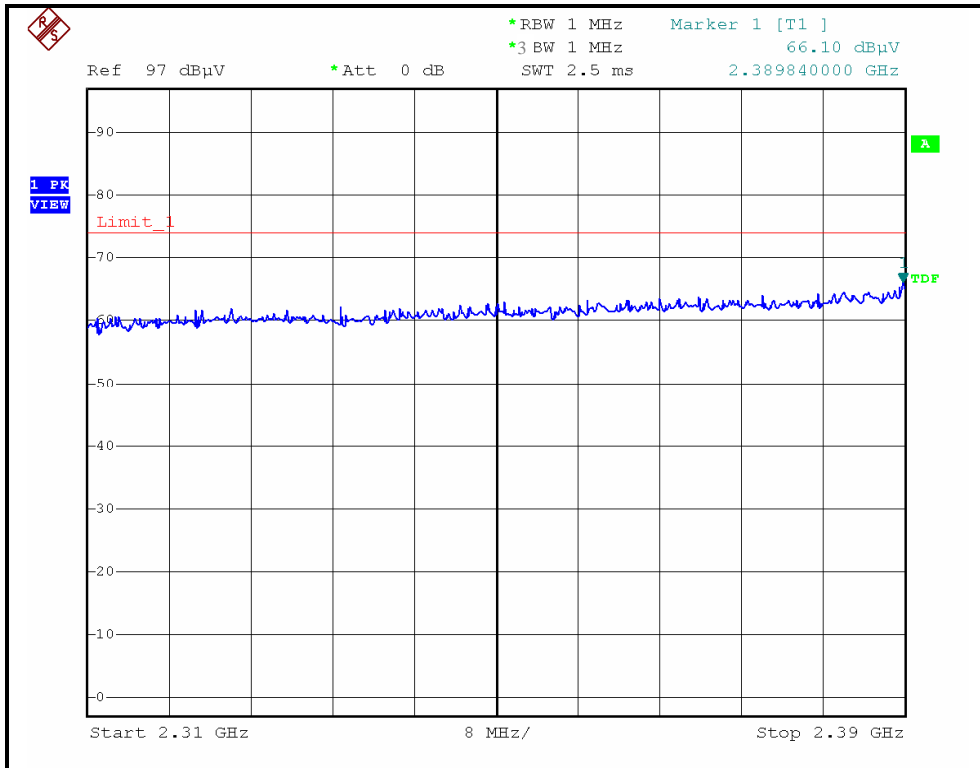



A D T

### RESTRICTED BANDEDGE (DRAFT 802.11n (20MHz) MODE,CH1, VERTICAL )

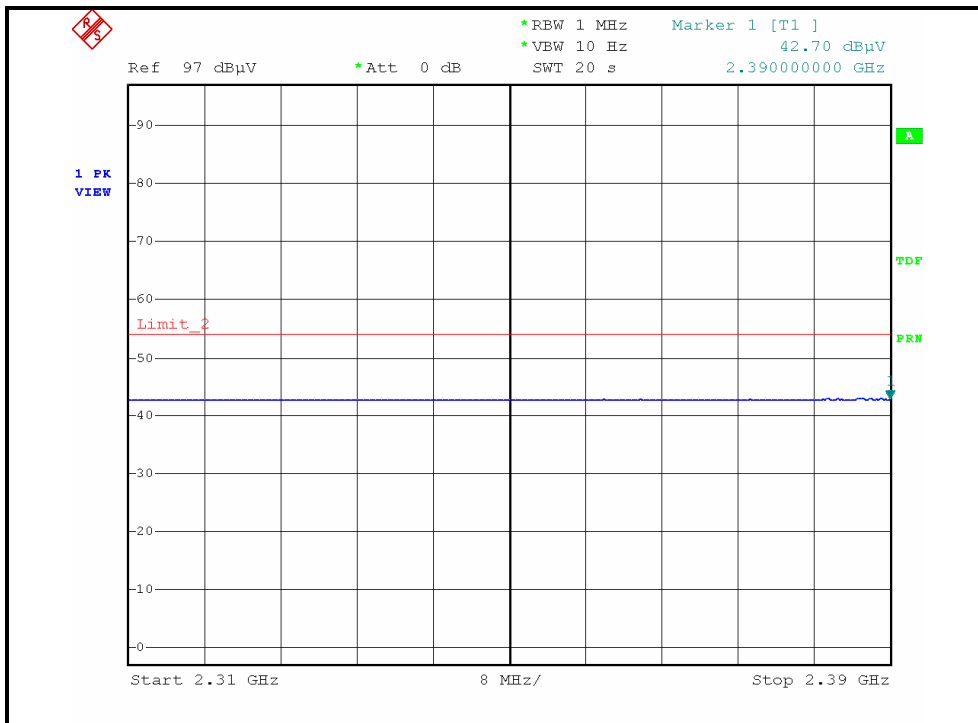
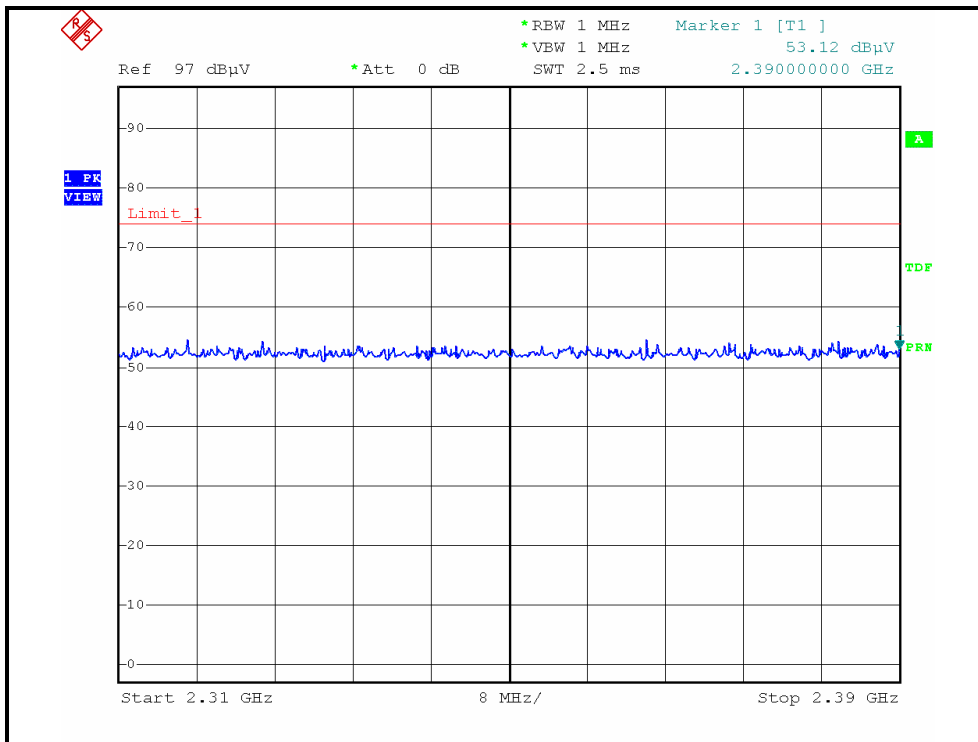



A D T

### RESTRICTED BANDEGE (DRAFT 802.11n (20MHz) MODE, CH11, HORIZONTAL )

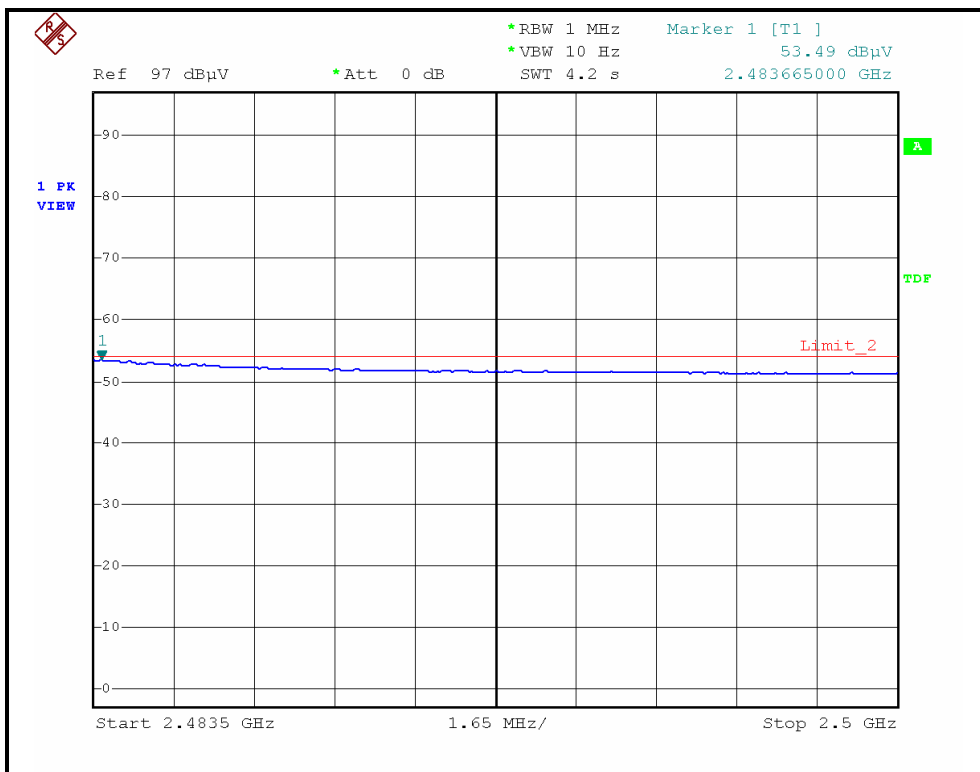
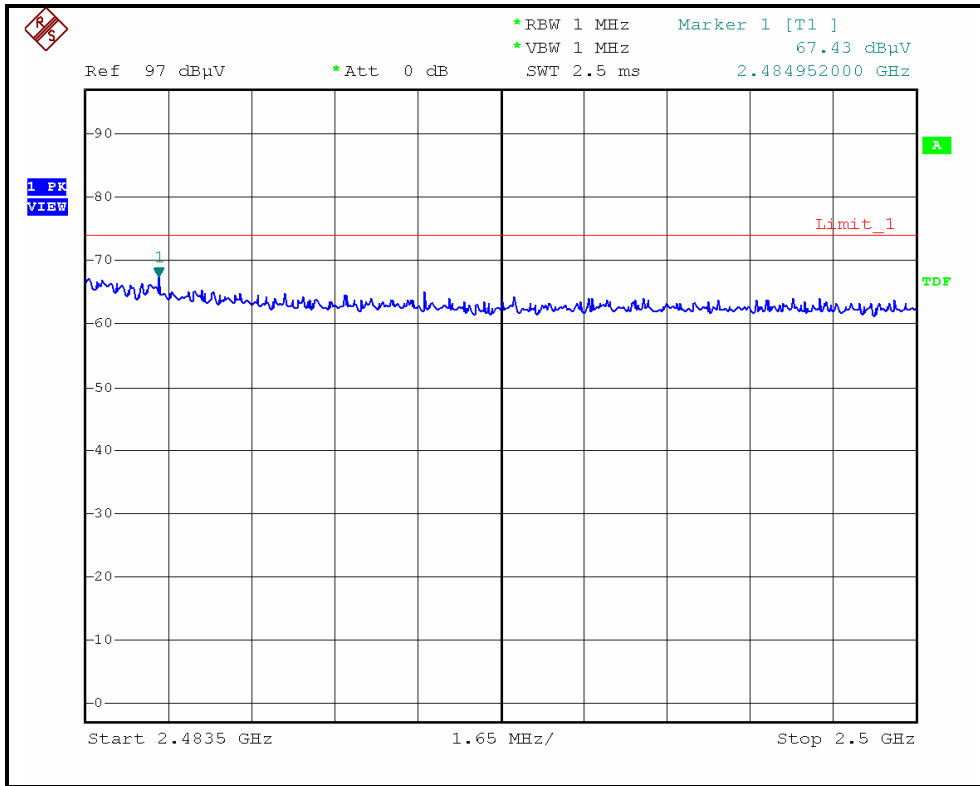





A D T

### RESTRICTED BANDEDGE (DRAFT 802.11n (20MHz) MODE,CH11, VERTICAL )

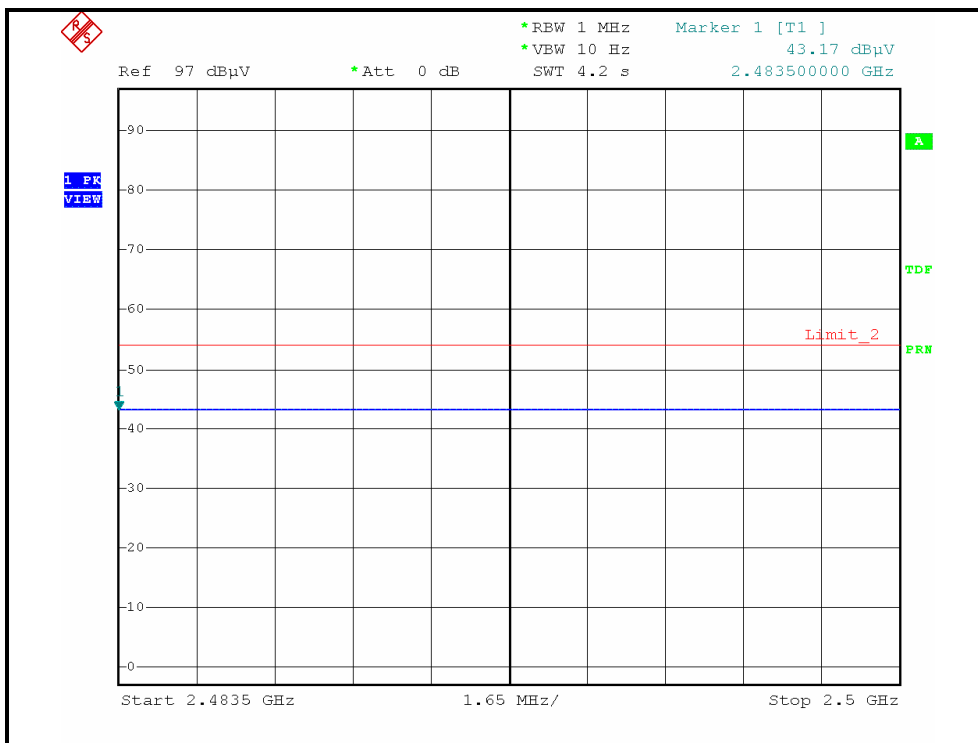
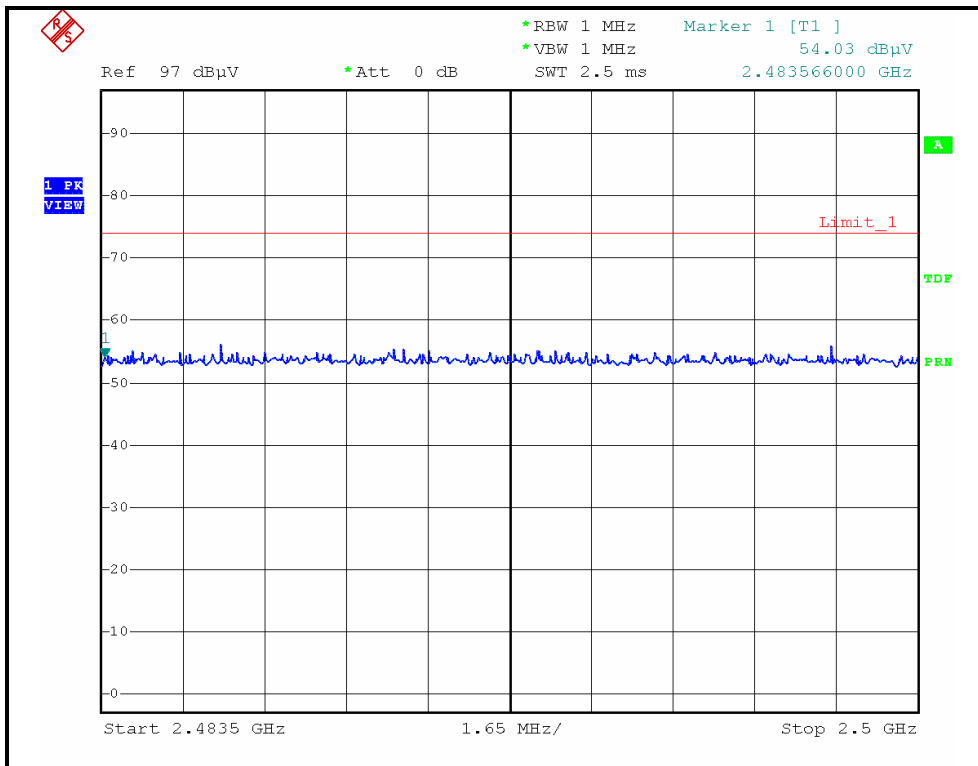



A D T

**DRAFT 802.11n (40MHz) OFDM MODULATION**

EUT TEST CONDITION		MEASUREMENT DETAIL	
CHANNEL	Channel 1	FREQUENCY RANGE	1 ~ 25GHz
INPUT POWER	120Vac, 60 Hz	DETECTOR FUNCTION	Peak (PK) Average (AV)
ENVIRONMENTAL CONDITIONS	30.0deg. C, 55.0%RH 965hPa	TESTED BY	Eric Lee

**ANTENNA POLARITY & TEST DISTANCE: HORIZONTAL AT 3 M**

NO.	FREQ. (MHz)	EMISSION LEVEL (dBuV/m)	LIMIT (dBuV/m)	MARGIN (dB)	ANTENNA HEIGHT (m)	TABLE ANGLE (Degree)	RAW VALUE (dBuV)	CORRECTION FACTOR (dB/m)
1	2390.00	71.86 PK	74.00	-2.14	1.55 H	97	41.80	30.06
2	2390.00	53.48 AV	54.00	-0.52	1.55 H	97	23.42	30.06
3	*2422.00	109.91 PK			1.77 H	95	79.72	30.19
4	*2422.00	96.88 AV			1.77 H	95	66.69	30.19
5	4844.00	46.73 PK	74.00	-27.27	1.20 H	58	11.23	35.50
6	4844.00	33.89 AV	54.00	-20.11	1.20 H	58	-1.61	35.50
7	7266.00	54.56 PK	74.00	-19.44	1.45 H	62	12.63	41.93
8	7266.00	39.97 AV	54.00	-14.03	1.45 H	62	-1.96	41.93

**ANTENNA POLARITY & TEST DISTANCE: VERTICAL AT 3 M**

NO.	FREQ. (MHz)	EMISSION LEVEL (dBuV/m)	LIMIT (dBuV/m)	MARGIN (dB)	ANTENNA HEIGHT (m)	TABLE ANGLE (Degree)	RAW VALUE (dBuV)	CORRECTION FACTOR (dB/m)
1	2390.00	53.30 PK	74.00	-20.70	1.01 V	106	23.24	30.06
2	2390.00	42.90 AV	54.00	-11.10	1.01 V	106	12.84	30.06
3	*2422.00	91.80 PK			1.02 V	98	61.61	30.19
4	*2422.00	80.60 AV			1.02 V	98	50.41	30.19
5	4844.00	46.54 PK	74.00	-27.46	1.04 V	72	11.04	35.50
6	4844.00	33.40 AV	54.00	-20.60	1.04 V	72	-2.10	35.50
7	7266.00	53.48 PK	74.00	-20.52	1.24 V	37	11.55	41.93
8	7266.00	39.78 AV	54.00	-14.22	1.24 V	37	-2.15	41.93

- REMARKS:**
1. Emission level (dBuV/m) = Raw Value (dBuV) + Correction Factor (dB/m).
  2. Correction Factor (dB/m) = Antenna Factor (dB/m) + Cable Factor (dB).
  3. The other emission levels were very low against the limit.
  4. Margin value = Emission level – Limit value.
  5. “ \* “: Fundamental frequency.



A D T

EUT TEST CONDITION		MEASUREMENT DETAIL	
CHANNEL	Channel 4	FREQUENCY RANGE	1 ~ 25GHz
INPUT POWER	120Vac, 60 Hz	DETECTOR FUNCTION	Peak (PK) Average (AV)
ENVIRONMENTAL CONDITIONS	30.0deg. C, 55.0%RH 965hPa	TESTED BY	Eric Lee

**ANTENNA POLARITY & TEST DISTANCE: HORIZONTAL AT 3 M**

NO.	FREQ. (MHz)	EMISSION LEVEL (dBuV/m)	LIMIT (dBuV/m)	MARGIN (dB)	ANTENNA HEIGHT (m)	TABLE ANGLE (Degree)	RAW VALUE (dBuV)	CORRECTION FACTOR (dB/m)
1	2390.00	65.11 PK	74.00	-8.89	1.78 H	48	35.05	30.06
2	2390.00	52.76 AV	54.00	-1.24	1.78 H	48	22.70	30.06
3	*2437.00	112.67 PK			1.78 H	136	82.43	30.24
4	*2437.00	99.50 AV			1.78 H	136	69.26	30.24
5	2483.50	65.84 PK	74.00	-8.16	1.78 H	98	35.41	30.43
6	2483.50	53.01 AV	54.00	-0.99	1.78 H	98	22.58	30.43
7	4874.00	45.69 PK	74.00	-28.31	1.20 H	16	10.14	35.55
8	4874.00	33.57 AV	54.00	-20.43	1.20 H	16	-1.98	35.55
9	7311.00	54.62 PK	74.00	-19.38	1.30 H	281	12.58	42.04
10	7311.00	39.58 AV	54.00	-14.42	1.30 H	281	-2.46	42.04

**ANTENNA POLARITY & TEST DISTANCE: VERTICAL AT 3 M**

NO.	FREQ. (MHz)	EMISSION LEVEL (dBuV/m)	LIMIT (dBuV/m)	MARGIN (dB)	ANTENNA HEIGHT (m)	TABLE ANGLE (Degree)	RAW VALUE (dBuV)	CORRECTION FACTOR (dB/m)
1	*2437.00	93.40 PK			1.01 V	102	63.16	30.24
2	*2437.00	82.80 AV			1.01 V	102	52.56	30.24
3	4874.00	45.52 PK	74.00	-28.48	1.02 V	247	9.97	35.55
4	4874.00	33.12 AV	54.00	-20.88	1.02 V	247	-2.43	35.55
5	7311.00	54.23 PK	74.00	-19.77	1.22 V	37	12.19	42.04
6	7311.00	39.47 AV	54.00	-14.53	1.22 V	37	-2.57	42.04

- REMARKS:**
1. Emission level (dBuV/m) = Raw Value (dBuV) + Correction Factor (dB/m).
  2. Correction Factor (dB/m) = Antenna Factor (dB/m) + Cable Factor (dB).
  3. The other emission levels were very low against the limit.
  4. Margin value = Emission level – Limit value.
  5. “ \* “: Fundamental frequency.



A D T

EUT TEST CONDITION		MEASUREMENT DETAIL	
CHANNEL	Channel 7	FREQUENCY RANGE	1 ~ 25GHz
INPUT POWER	120Vac, 60 Hz	DETECTOR FUNCTION	Peak (PK) Average (AV)
ENVIRONMENTAL CONDITIONS	30.0deg. C, 55.0%RH 965hPa	TESTED BY	Eric Lee

**ANTENNA POLARITY & TEST DISTANCE: HORIZONTAL AT 3 M**

NO.	FREQ. (MHz)	EMISSION LEVEL (dBuV/m)	LIMIT (dBuV/m)	MARGIN (dB)	ANTENNA HEIGHT (m)	TABLE ANGLE (Degree)	RAW VALUE (dBuV)	CORRECTION FACTOR (dB/m)
1	*2452.00	109.43 PK			1.78 H	96	79.13	30.30
2	*2452.00	96.48 AV			1.78 H	96	66.18	30.30
3	2483.50	72.16 PK	74.00	-1.84	1.75 H	96	41.73	30.43
4	2483.50	53.41 AV	54.00	-0.59	1.75 H	96	22.98	30.43
5	4904.00	45.57 PK	74.00	-28.43	1.08 H	56	9.97	35.60
6	4904.00	32.69 AV	54.00	-21.31	1.08 H	56	-2.91	35.60
7	7356.00	54.85 PK	74.00	-19.15	1.11 H	168	12.69	42.16
8	7356.00	39.77 AV	54.00	-14.23	1.11 H	168	-2.39	42.16

**ANTENNA POLARITY & TEST DISTANCE: VERTICAL AT 3 M**

NO.	FREQ. (MHz)	EMISSION LEVEL (dBuV/m)	LIMIT (dBuV/m)	MARGIN (dB)	ANTENNA HEIGHT (m)	TABLE ANGLE (Degree)	RAW VALUE (dBuV)	CORRECTION FACTOR (dB/m)
1	*2452.00	91.40 PK			1.00 V	102	61.10	30.30
2	*2452.00	80.30 AV			1.00 V	102	50.00	30.30
3	2483.50	53.03 PK	74.00	-20.97	1.00 V	58	22.60	30.43
4	2483.50	43.96 AV	54.00	-10.04	1.00 V	58	13.53	30.43
5	4904.00	45.69 PK	74.00	-28.31	1.04 V	63	10.09	35.60
6	4904.00	33.72 AV	54.00	-20.28	1.04 V	63	-1.88	35.60
7	7356.00	54.63 PK	74.00	-19.37	1.29 V	24	12.47	42.16
8	7356.00	39.12 AV	54.00	-14.88	1.29 V	24	-3.04	42.16

- REMARKS:**
1. Emission level (dBuV/m) = Raw Value (dBuV) + Correction Factor (dB/m).
  2. Correction Factor (dB/m) = Antenna Factor (dB/m) + Cable Factor (dB).
  3. The other emission levels were very low against the limit.
  4. Margin value = Emission level – Limit value.
  5. “ \* “: Fundamental frequency.



A D T

### RESTRICTED BANDEDGE (DRAFT 802.11n (40MHz) MODE, CH1, HORIZONTAL )

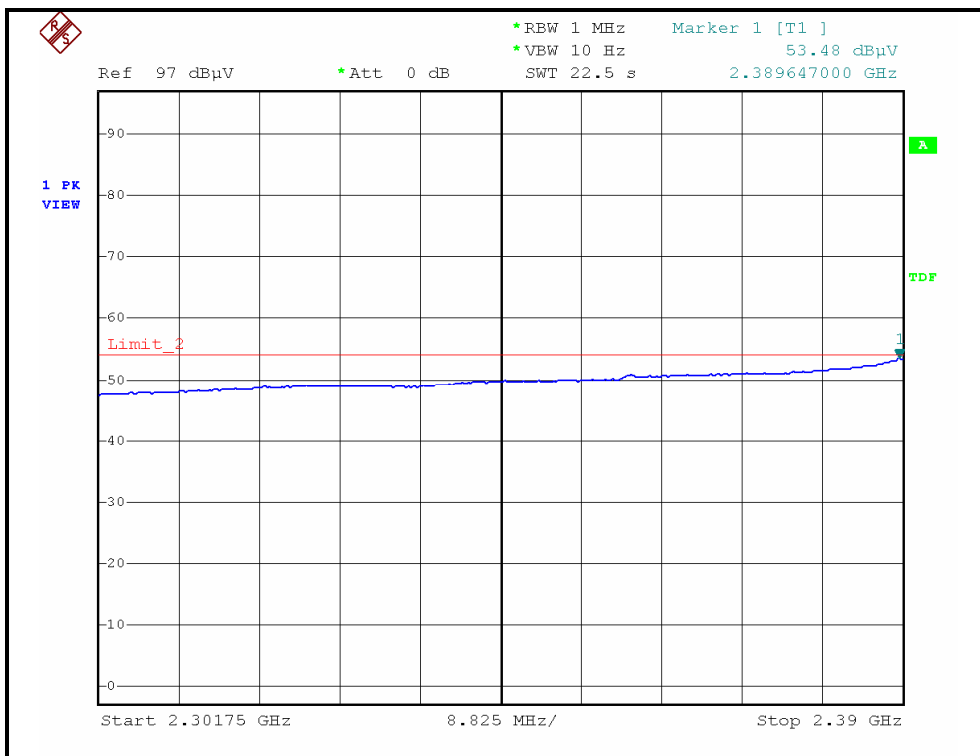
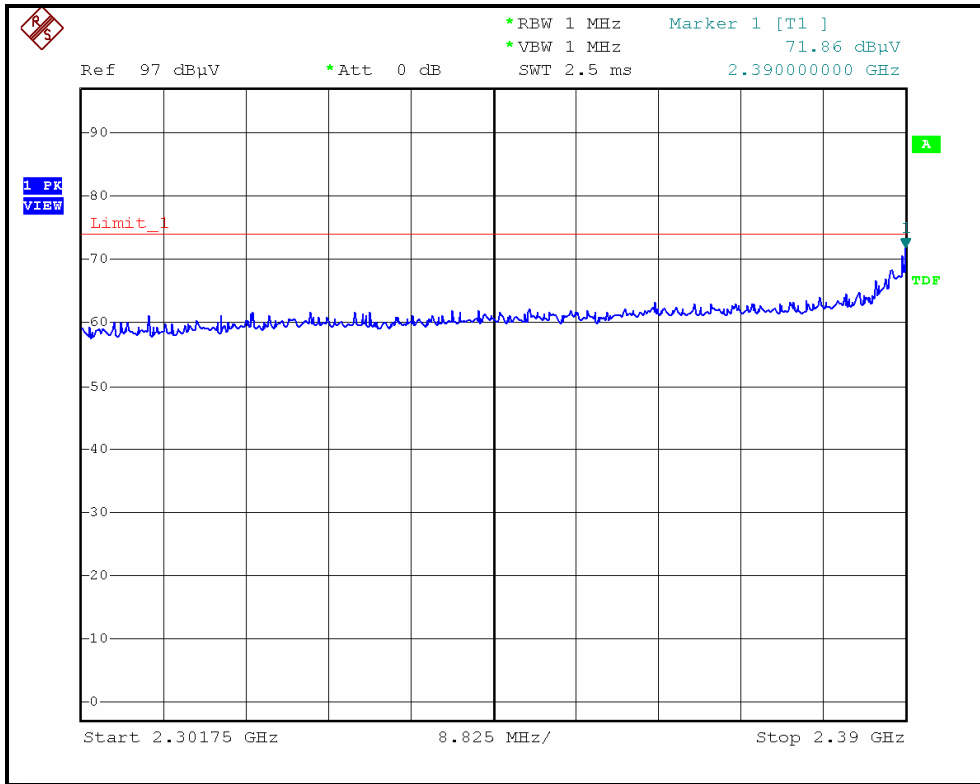



A D T

### RESTRICTED BANDEDGE (DRAFT 802.11n (40MHz) MODE,CH1, VERTICAL )

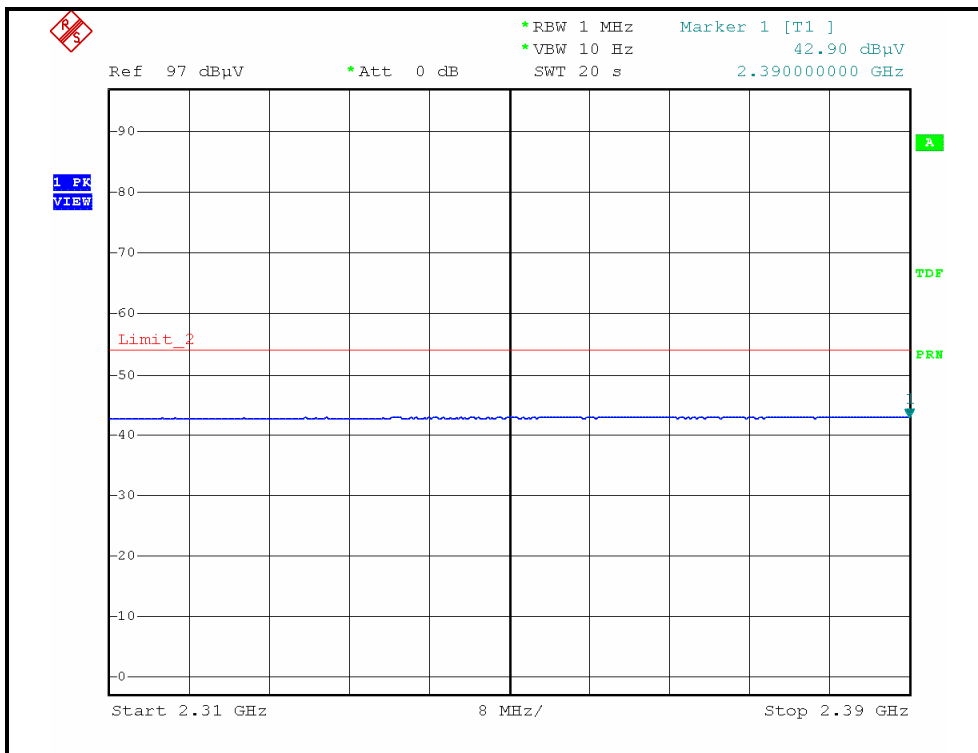
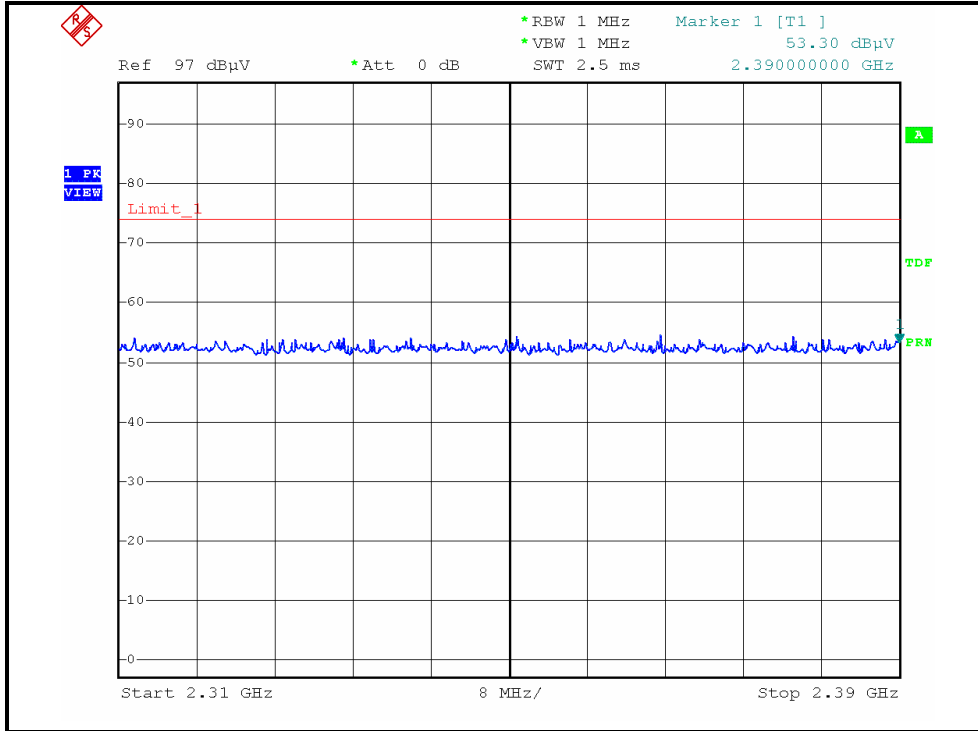



A D T

### RESTRICTED BANDEDGE (DRAFT 802.11n (40MHz) MODE,CH7, HORIZONTAL )

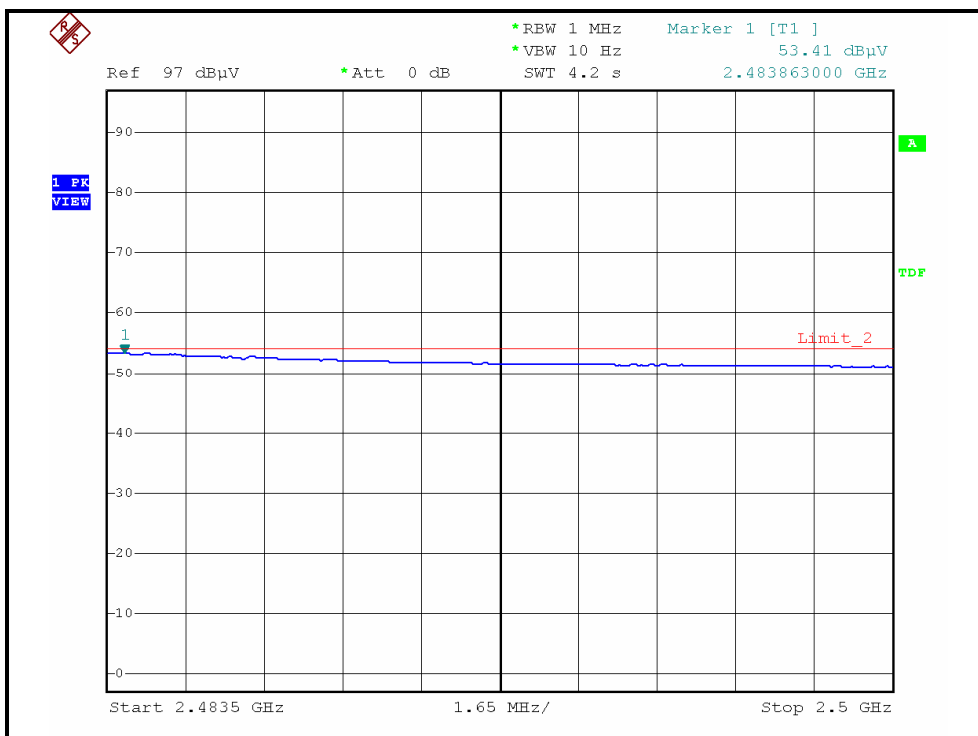
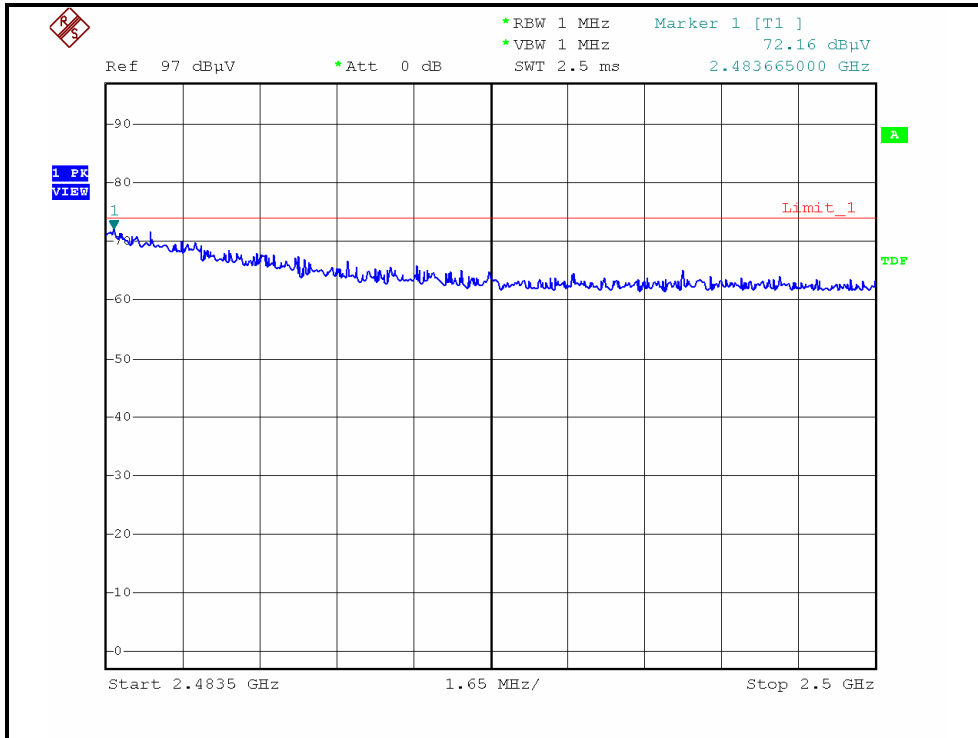



A D T

### RESTRICTED BANDEDGE (DRAFT 802.11n (40MHz) MODE,CH7, VERTICAL )

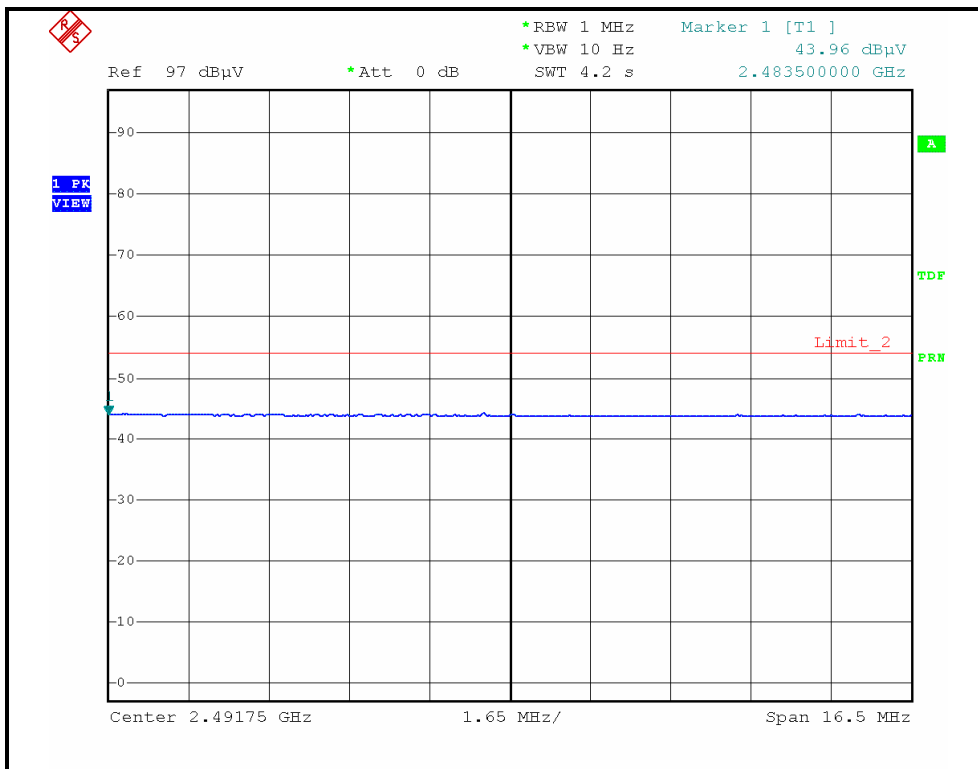
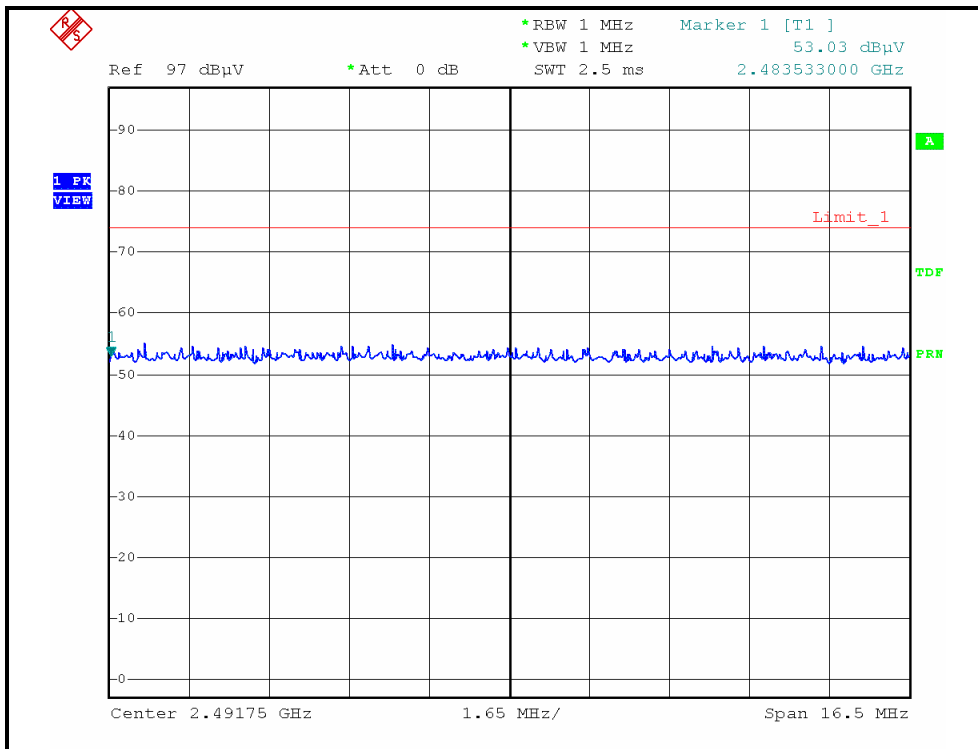





A D T

## 4.2.8 TEST RESULTS –ANTENNA 2

## BELOW 1GHz WORST-CASE DATA : 802.11b DSSS MODULATION

EUT TEST CONDITION		MEASUREMENT DETAIL	
CHANNEL	Channel 1	FREQUENCY RANGE	Below 1000MHz
INPUT POWER	120Vac, 60 Hz	DETECTOR FUNCTION	Quasi-Peak
ENVIRONMENTAL CONDITIONS	25.0deg. C, 72.0%RH 965hPa	TESTED BY	Frank Liu

ANTENNA POLARITY & TEST DISTANCE: HORIZONTAL AT 3 M								
NO.	FREQ. (MHz)	EMISSION LEVEL (dBuV/m)	LIMIT (dBuV/m)	MARGIN (dB)	ANTENNA HEIGHT (m)	TABLE ANGLE (Degree)	RAW VALUE (dBuV)	CORRECTION FACTOR (dB/m)
1	125.00	27.53 QP	43.50	-15.97	2.13 H	46	14.46	13.07
2	250.00	43.35 QP	46.00	-2.65	1.00 H	256	29.10	14.25
3	274.00	35.84 QP	46.00	-10.16	1.13 H	37	20.34	15.50
4	375.00	39.15 QP	46.00	-6.85	1.26 H	64	20.34	18.81
5	649.99	39.37 QP	46.00	-6.63	1.00 H	209	13.84	25.53
6	749.99	38.37 QP	46.00	-7.63	1.00 H	159	11.46	26.91
7	999.98	38.05 QP	54.00	-15.95	1.00 H	264	7.31	30.74

ANTENNA POLARITY & TEST DISTANCE: VERTICAL AT 3 M								
NO.	FREQ. (MHz)	EMISSION LEVEL (dBuV/m)	LIMIT (dBuV/m)	MARGIN (dB)	ANTENNA HEIGHT (m)	TABLE ANGLE (Degree)	RAW VALUE (dBuV)	CORRECTION FACTOR (dB/m)
1	44.96	32.17 QP	40.00	-7.83	1.00 V	167	17.38	14.79
2	132.00	27.03 QP	43.50	-16.47	1.13 V	276	13.24	13.79
3	250.00	34.59 QP	46.00	-11.41	1.00 V	64	20.34	14.25
4	650.00	36.23 QP	46.00	-9.77	1.00 V	267	10.70	25.53
5	875.00	35.69 QP	46.00	-10.31	1.00 V	253	6.40	29.29
6	999.98	37.06 QP	54.00	-16.94	1.00 V	126	6.32	30.74

- REMARKS:**
1. Emission level (dBuV/m) = Raw Value (dBuV) + Correction Factor (dB/m).
  2. Correction Factor (dB/m) = Antenna Factor (dB/m) + Cable Factor (dB).
  3. The other emission levels were very low against the limit.
  4. Margin value = Emission level – Limit value.



A D T

## ABOVE 1GHz WORST-CASE DATA

### 802.11b DSSS MODULATION

EUT TEST CONDITION		MEASUREMENT DETAIL	
CHANNEL	Channel 1	FREQUENCY RANGE	1 ~ 25GHz
INPUT POWER	120Vac, 60 Hz	DETECTOR FUNCTION	Peak (PK) Average (AV)
ENVIRONMENTAL CONDITIONS	30.0deg. C, 55.0%RH 965hPa	TESTED BY	Eric Lee

ANTENNA POLARITY & TEST DISTANCE: HORIZONTAL AT 3 M								
NO.	FREQ. (MHz)	EMISSION LEVEL (dBuV/m)	LIMIT (dBuV/m)	MARGIN (dB)	ANTENNA HEIGHT (m)	TABLE ANGLE (Degree)	RAW VALUE (dBuV)	CORRECTION FACTOR (dB/m)
1	2386.00	55.96 PK	74.00	-18.04	1.50 H	62	25.91	30.05
2	2386.00	43.97 AV	54.00	-10.03	1.50 H	62	13.92	30.05
3	*2412.00	104.92 PK			1.51 H	42	74.77	30.15
4	*2412.00	99.95 AV			1.51 H	42	69.80	30.15
5	4824.00	47.47 PK	74.00	-26.53	1.32 H	349	12.01	35.46
6	4824.00	33.87 AV	54.00	-20.13	1.32 H	349	-1.59	35.46
ANTENNA POLARITY & TEST DISTANCE: VERTICAL AT 3 M								
NO.	FREQ. (MHz)	EMISSION LEVEL (dBuV/m)	LIMIT (dBuV/m)	MARGIN (dB)	ANTENNA HEIGHT (m)	TABLE ANGLE (Degree)	RAW VALUE (dBuV)	CORRECTION FACTOR (dB/m)
1	2386.00	62.86 PK	74.00	-11.14	1.00 V	12	32.81	30.05
2	2386.00	52.85 AV	54.00	-1.15	1.00 V	12	22.80	30.05
3	*2412.00	124.45 PK			1.00 V	359	94.30	30.15
4	*2412.00	119.81 AV			1.00 V	359	89.66	30.15
5	4824.00	47.92 PK	74.00	-26.08	1.00 V	77	12.46	35.46
6	4824.00	34.19 AV	54.00	-19.81	1.00 V	77	-1.27	35.46

- REMARKS:**
1. Emission level (dBuV/m) = Raw Value (dBuV) + Correction Factor (dB/m).
  2. Correction Factor (dB/m) = Antenna Factor (dB/m) + Cable Factor (dB).
  3. The other emission levels were very low against the limit.
  4. Margin value = Emission level – Limit value.
  5. “ \* “: Fundamental frequency.



A D T

EUT TEST CONDITION		MEASUREMENT DETAIL	
CHANNEL	Channel 6	FREQUENCY RANGE	1 ~ 25GHz
INPUT POWER	120Vac, 60 Hz	DETECTOR FUNCTION	Peak (PK) Average (AV)
ENVIRONMENTAL CONDITIONS	30.0deg. C, 55.0%RH 965hPa	TESTED BY	Eric Lee

**ANTENNA POLARITY & TEST DISTANCE: HORIZONTAL AT 3 M**

NO.	FREQ. (MHz)	EMISSION LEVEL (dBuV/m)	LIMIT (dBuV/m)	MARGIN (dB)	ANTENNA HEIGHT (m)	TABLE ANGLE (Degree)	RAW VALUE (dBuV)	CORRECTION FACTOR (dB/m)
1	*2437.00	106.70 PK			1.54 H	129	76.46	30.24
2	*2437.00	101.04 AV			1.54 H	129	70.80	30.24
3	2483.50	55.24 PK	74.00	-18.76	1.57 H	161	24.81	30.43
4	2483.50	43.84 AV	54.00	-10.16	1.57 H	161	13.41	30.43
5	4874.00	47.24 PK	74.00	-26.76	1.31 H	54	11.69	35.55
6	4874.00	33.44 AV	54.00	-20.56	1.31 H	54	-2.11	35.55
7	7311.00	56.80 PK	74.00	-17.20	1.24 H	47	14.76	42.04
8	7311.00	44.30 AV	54.00	-9.70	1.24 H	47	2.26	42.04

**ANTENNA POLARITY & TEST DISTANCE: VERTICAL AT 3 M**

NO.	FREQ. (MHz)	EMISSION LEVEL (dBuV/m)	LIMIT (dBuV/m)	MARGIN (dB)	ANTENNA HEIGHT (m)	TABLE ANGLE (Degree)	RAW VALUE (dBuV)	CORRECTION FACTOR (dB/m)
1	2390.00	65.68 PK	74.00	-8.32	1.00 V	5	35.62	30.06
2	2390.00	51.39 AV	54.00	-2.61	1.00 V	5	21.33	30.06
3	*2437.00	126.18 PK			1.00 V	1	95.94	30.24
4	*2437.00	121.76 AV			1.00 V	1	91.52	30.24
5	2483.50	65.22 PK	74.00	-8.78	1.00 V	0	34.79	30.43
6	2483.50	52.23 AV	54.00	-1.77	1.00 V	0	21.80	30.43
7	4874.00	47.98 PK	74.00	-26.02	1.50 V	74	12.43	35.55
8	4874.00	34.80 AV	54.00	-19.20	1.50 V	74	-0.75	35.55
9	7311.00	57.01 PK	74.00	-16.99	1.12 V	4	14.97	42.04
10	7311.00	45.81 AV	54.00	-8.19	1.12 V	4	3.77	42.04

- REMARKS:**
1. Emission level (dBuV/m) = Raw Value (dBuV) + Correction Factor (dB/m).
  2. Correction Factor (dB/m) = Antenna Factor (dB/m) + Cable Factor (dB).
  3. The other emission levels were very low against the limit.
  4. Margin value = Emission level – Limit value.
  5. “ \* “: Fundamental frequency.



A D T

EUT TEST CONDITION		MEASUREMENT DETAIL	
CHANNEL	Channel 11	FREQUENCY RANGE	1 ~ 25GHz
INPUT POWER	120Vac, 60 Hz	DETECTOR FUNCTION	Peak (PK) Average (AV)
ENVIRONMENTAL CONDITIONS	30.0deg. C, 55.0%RH 965hPa	TESTED BY	Eric Lee

**ANTENNA POLARITY & TEST DISTANCE: HORIZONTAL AT 3 M**

NO.	FREQ. (MHz)	EMISSION LEVEL (dBuV/m)	LIMIT (dBuV/m)	MARGIN (dB)	ANTENNA HEIGHT (m)	TABLE ANGLE (Degree)	RAW VALUE (dBuV)	CORRECTION FACTOR (dB/m)
1	*2462.00	105.10 PK			1.47 H	100	74.76	30.34
2	*2462.00	100.34 AV			1.47 H	100	70.00	30.34
3	2488.00	54.56 PK	74.00	-19.44	1.51 H	159	24.12	30.44
4	2488.00	43.67 AV	54.00	-10.33	1.51 H	159	13.23	30.44
5	4924.00	47.84 PK	74.00	-26.16	1.02 H	247	12.21	35.63
6	4924.00	35.62 AV	54.00	-18.38	1.02 H	247	-0.01	35.63
7	7386.00	56.10 PK	74.00	-17.90	1.32 H	54	13.87	42.23
8	7386.00	43.20 AV	54.00	-10.80	1.32 H	54	0.97	42.23

**ANTENNA POLARITY & TEST DISTANCE: VERTICAL AT 3 M**

NO.	FREQ. (MHz)	EMISSION LEVEL (dBuV/m)	LIMIT (dBuV/m)	MARGIN (dB)	ANTENNA HEIGHT (m)	TABLE ANGLE (Degree)	RAW VALUE (dBuV)	CORRECTION FACTOR (dB/m)
1	*2462.00	124.80 PK			1.00 V	1	94.46	30.34
2	*2462.00	120.04 AV			1.00 V	1	89.70	30.34
3	2487.00	64.48 PK	74.00	-9.52	1.00 V	2	34.04	30.44
4	2487.00	53.44 AV	54.00	-0.56	1.00 V	2	23.00	30.44
5	4924.00	47.97 PK	74.00	-26.03	1.02 V	24	12.34	35.63
6	4924.00	34.25 AV	54.00	-19.75	1.02 V	24	-1.38	35.63
7	7386.00	55.81 PK	74.00	-18.19	1.10 V	5	13.58	42.23
8	7386.00	42.77 AV	54.00	-11.23	1.10 V	5	0.54	42.23

- REMARKS:**
1. Emission level (dBuV/m) = Raw Value (dBuV) + Correction Factor (dB/m).
  2. Correction Factor (dB/m) = Antenna Factor (dB/m) + Cable Factor (dB).
  3. The other emission levels were very low against the limit.
  4. Margin value = Emission level – Limit value.
  5. “ \* “: Fundamental frequency.



A D T

### RESTRICTED BANDEDGE (802.11b MODE,CH1, HORIZONTAL )

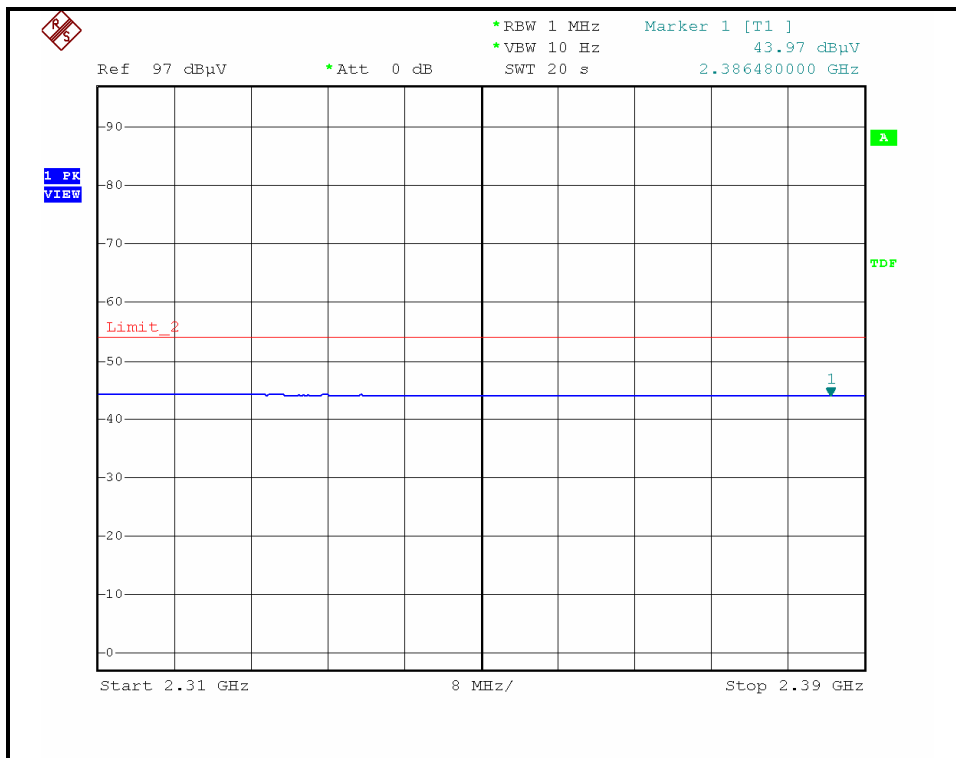
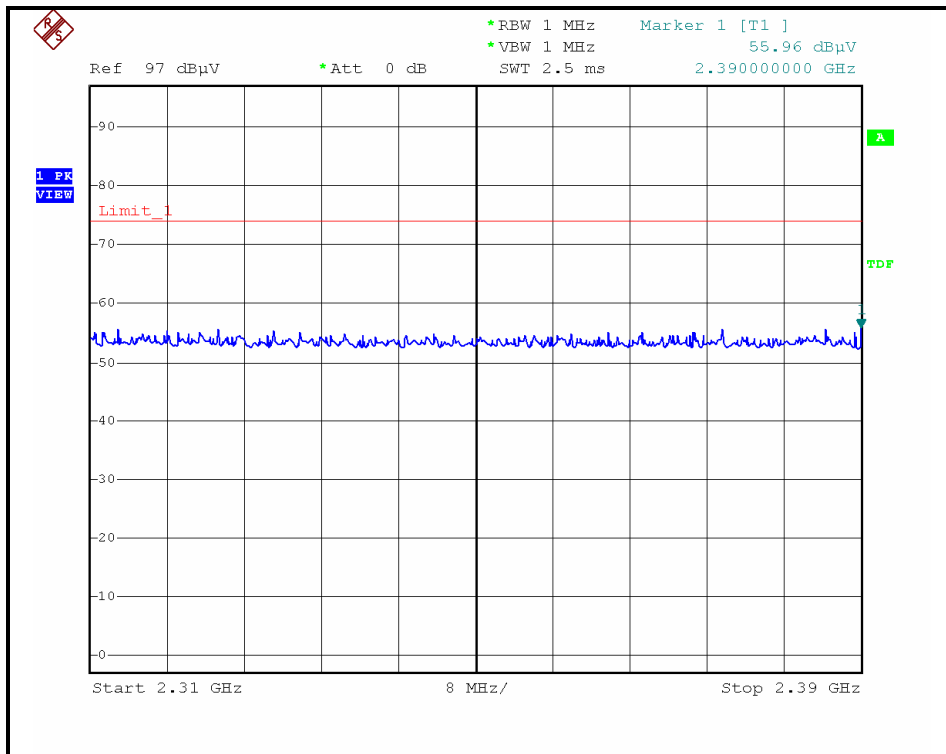



A D T

### RESTRICTED BANDEDGE (802.11b MODE,CH1, VERTICAL )

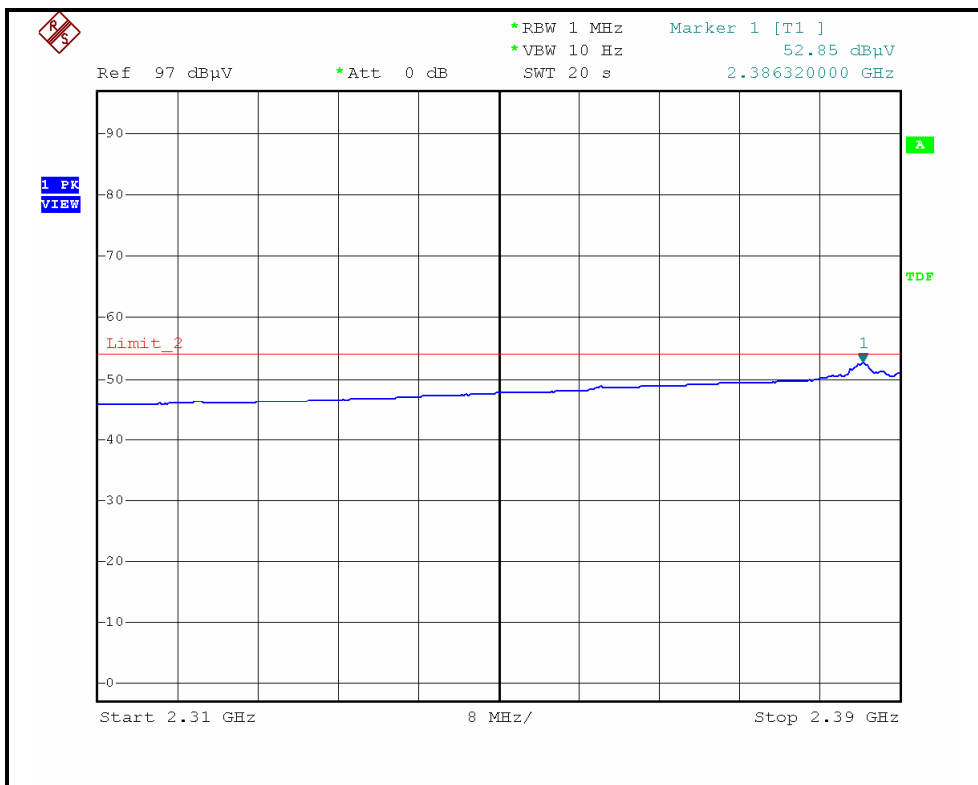
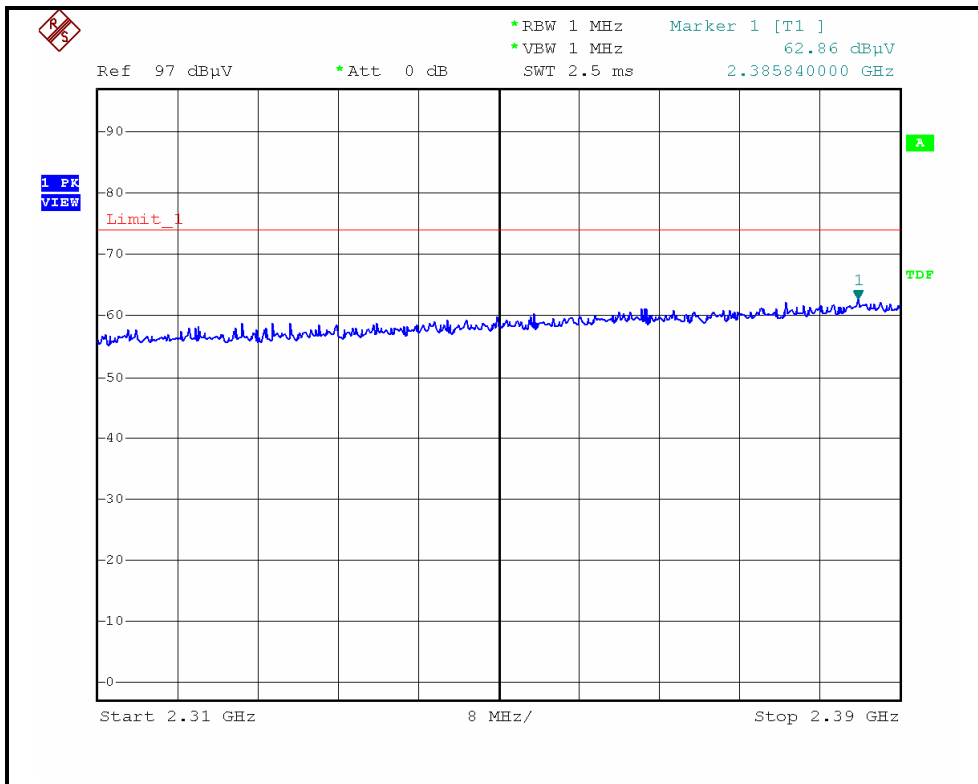



A D T

### RESTRICTED BANDEDGE (802.11b MODE,CH11, HORIZONTAL )

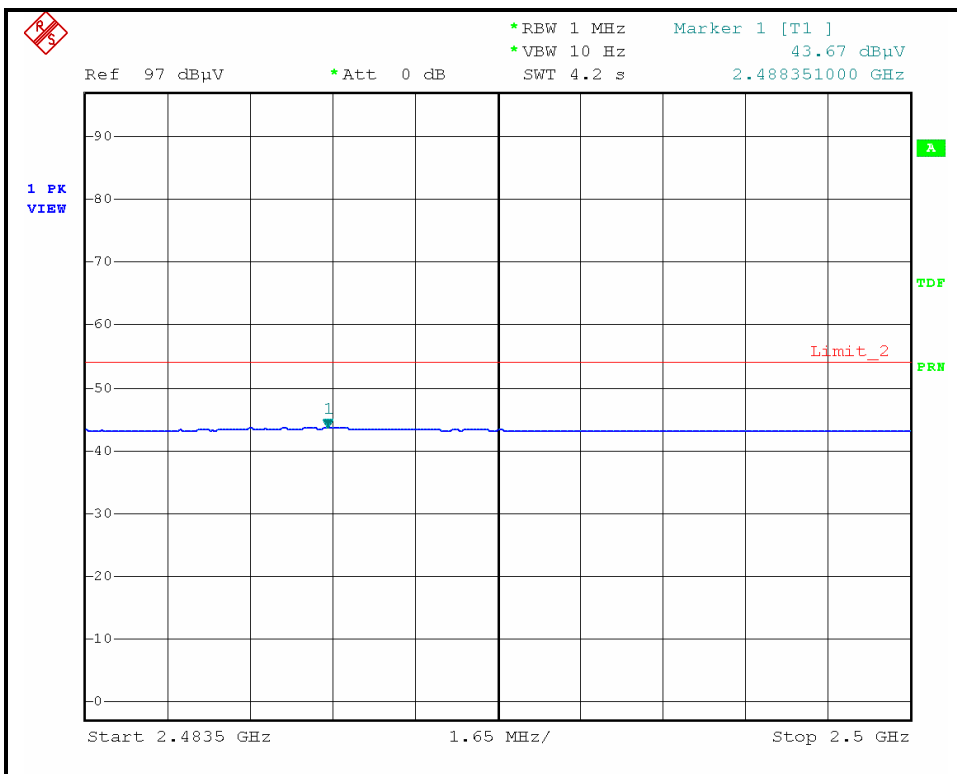
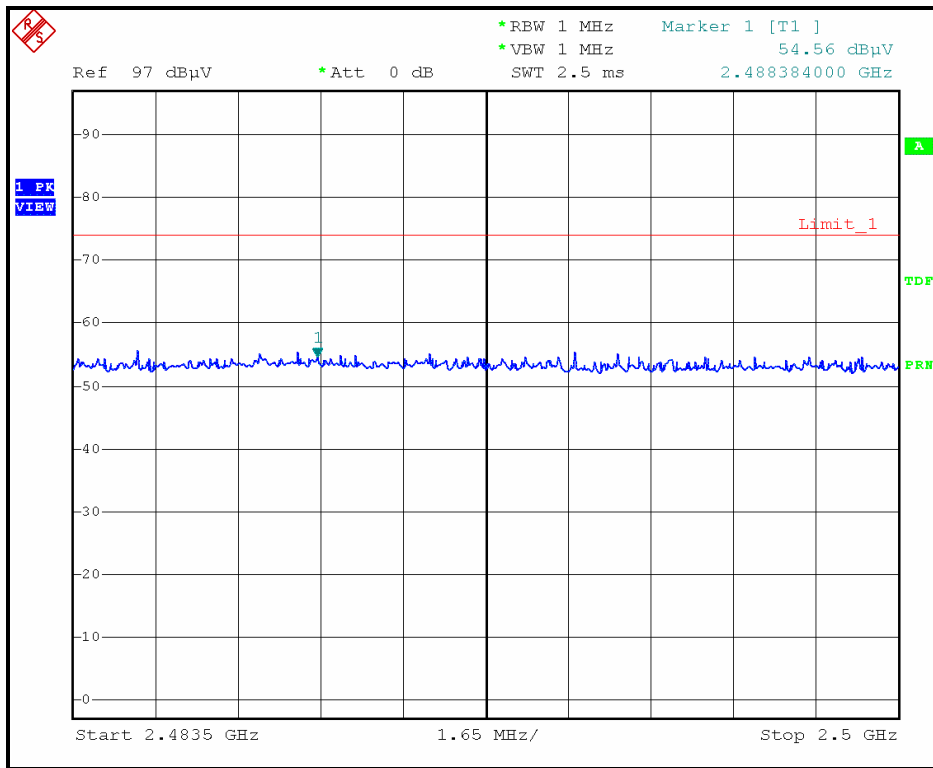



A D T

### RESTRICTED BANDEDGE (802.11b MODE, CH11, VERTICAL )

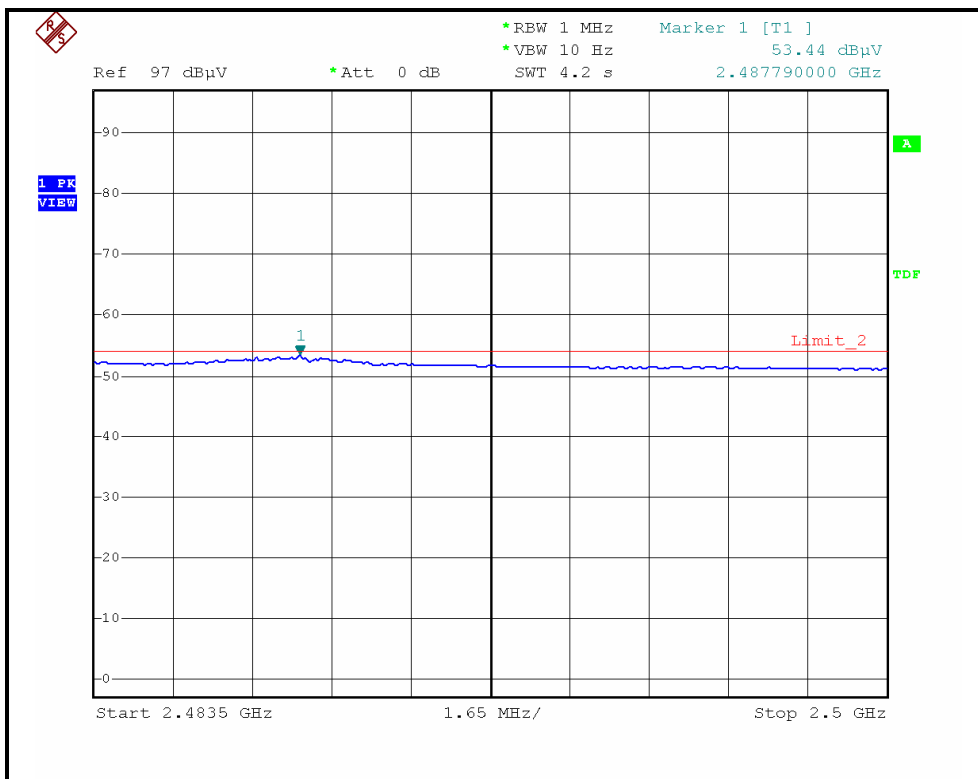
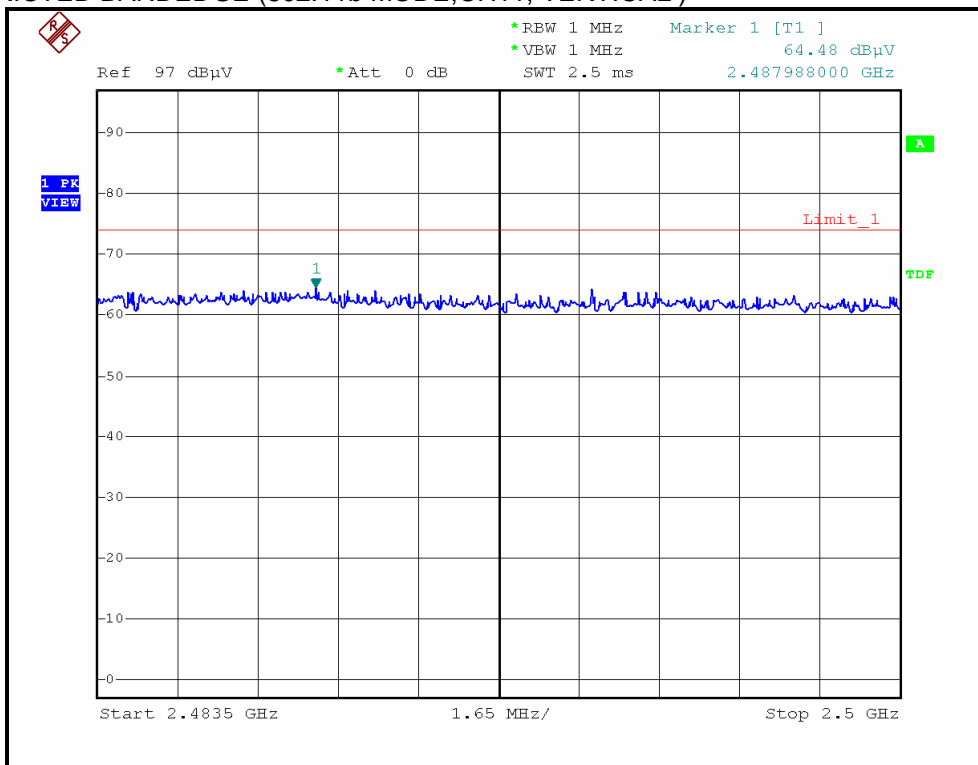





A D T

**802.11g OFDM MODULATION**

EUT TEST CONDITION		MEASUREMENT DETAIL	
CHANNEL	Channel 1	FREQUENCY RANGE	1 ~ 25GHz
INPUT POWER	120Vac, 60 Hz	DETECTOR FUNCTION	Peak (PK) Average (AV)
ENVIRONMENTAL CONDITIONS	30.0deg. C, 55.0%RH 965hPa	TESTED BY	Eric Lee

ANTENNA POLARITY & TEST DISTANCE: HORIZONTAL AT 3 M								
NO.	FREQ. (MHz)	EMISSION LEVEL (dBuV/m)	LIMIT (dBuV/m)	MARGIN (dB)	ANTENNA HEIGHT (m)	TABLE ANGLE (Degree)	RAW VALUE (dBuV)	CORRECTION FACTOR (dB/m)
1	2390.00	52.81 PK	74.00	-21.19	1.48 H	157	22.75	30.06
2	2390.00	43.07 AV	54.00	-10.93	1.48 H	157	13.01	30.06
3	*2412.00	100.14 PK			1.50 H	163	69.99	30.15
4	*2412.00	90.67 AV			1.50 H	163	60.52	30.15
5	4824.00	48.60 PK	74.00	-25.40	1.25 H	24	13.14	35.46
6	4824.00	34.20 AV	54.00	-19.80	1.25 H	24	-1.26	35.46
ANTENNA POLARITY & TEST DISTANCE: VERTICAL AT 3 M								
NO.	FREQ. (MHz)	EMISSION LEVEL (dBuV/m)	LIMIT (dBuV/m)	MARGIN (dB)	ANTENNA HEIGHT (m)	TABLE ANGLE (Degree)	RAW VALUE (dBuV)	CORRECTION FACTOR (dB/m)
1	2390.00	66.26 PK	74.00	-7.74	1.02 V	24	36.20	30.06
2	2390.00	53.08 AV	54.00	-0.92	1.02 V	24	23.02	30.06
3	*2412.00	121.33 PK			1.00 V	3	91.18	30.15
4	*2412.00	110.65 AV			1.00 V	3	80.50	30.15
5	4824.00	47.50 PK	74.00	-26.50	1.10 V	35	12.04	35.46
6	4824.00	33.96 AV	54.00	-20.04	1.10 V	35	-1.50	35.46

- REMARKS:**
1. Emission level (dBuV/m) = Raw Value (dBuV) + Correction Factor (dB/m).
  2. Correction Factor (dB/m) = Antenna Factor (dB/m) + Cable Factor (dB).
  3. The other emission levels were very low against the limit.
  4. Margin value = Emission level – Limit value.
  5. “ \* “: Fundamental frequency.



A D T

EUT TEST CONDITION		MEASUREMENT DETAIL	
CHANNEL	Channel 6	FREQUENCY RANGE	1 ~ 25GHz
INPUT POWER	120Vac, 60 Hz	DETECTOR FUNCTION	Peak (PK) Average (AV)
ENVIRONMENTAL CONDITIONS	30.0deg. C, 55.0%RH 965hPa	TESTED BY	Eric Lee

**ANTENNA POLARITY & TEST DISTANCE: HORIZONTAL AT 3 M**

NO.	FREQ. (MHz)	EMISSION LEVEL (dBuV/m)	LIMIT (dBuV/m)	MARGIN (dB)	ANTENNA HEIGHT (m)	TABLE ANGLE (Degree)	RAW VALUE (dBuV)	CORRECTION FACTOR (dB/m)
1	*2437.00	100.31 PK			1.51 H	324	70.07	30.24
2	*2437.00	90.84 AV			1.51 H	324	60.60	30.24
3	2483.50	53.10 PK	74.00	-20.90	1.25 H	54	22.67	30.43
4	2483.50	43.24 AV	54.00	-10.76	1.25 H	54	12.81	30.43
5	4874.00	48.70 PK	74.00	-25.30	1.32 H	348	13.15	35.55
6	4874.00	34.40 AV	54.00	-19.60	1.32 H	348	-1.15	35.55
7	7311.00	52.60 PK	74.00	-21.40	1.02 H	258	10.56	42.04
8	7311.00	38.20 AV	54.00	-15.80	1.02 H	258	-3.84	42.04

**ANTENNA POLARITY & TEST DISTANCE: VERTICAL AT 3 M**

NO.	FREQ. (MHz)	EMISSION LEVEL (dBuV/m)	LIMIT (dBuV/m)	MARGIN (dB)	ANTENNA HEIGHT (m)	TABLE ANGLE (Degree)	RAW VALUE (dBuV)	CORRECTION FACTOR (dB/m)
1	2390.00	64.14 PK	74.00	-9.86	1.00 V	10	34.08	30.06
2	2390.00	51.40 AV	54.00	-2.60	1.00 V	10	21.34	30.06
3	*2437.00	121.22 PK			1.00 V	357	90.98	30.24
4	*2437.00	110.86 AV			1.00 V	357	80.62	30.24
5	2483.50	65.56 PK	74.00	-8.44	1.00 V	0	35.13	30.43
6	2483.50	52.65 AV	54.00	-1.35	1.00 V	0	22.22	30.43
7	4874.00	47.63 PK	74.00	-26.37	1.00 V	14	12.08	35.55
8	4874.00	33.89 AV	54.00	-20.11	1.00 V	14	-1.66	35.55
9	7311.00	53.62 PK	74.00	-20.38	1.54 V	87	11.58	42.04
10	7311.00	39.88 AV	54.00	-14.12	1.54 V	87	-2.16	42.04

- REMARKS:**
1. Emission level (dBuV/m) = Raw Value (dBuV) + Correction Factor (dB/m).
  2. Correction Factor (dB/m) = Antenna Factor (dB/m) + Cable Factor (dB).
  3. The other emission levels were very low against the limit.
  4. Margin value = Emission level – Limit value.
  5. “ \* “: Fundamental frequency.



A D T

EUT TEST CONDITION		MEASUREMENT DETAIL	
CHANNEL	Channel 11	FREQUENCY RANGE	1 ~ 25GHz
INPUT POWER	120Vac, 60 Hz	DETECTOR FUNCTION	Peak (PK) Average (AV)
ENVIRONMENTAL CONDITIONS	30.0deg. C, 55.0%RH 965hPa	TESTED BY	Eric Lee

ANTENNA POLARITY & TEST DISTANCE: HORIZONTAL AT 3 M								
NO.	FREQ. (MHz)	EMISSION LEVEL (dBuV/m)	LIMIT (dBuV/m)	MARGIN (dB)	ANTENNA HEIGHT (m)	TABLE ANGLE (Degree)	RAW VALUE (dBuV)	CORRECTION FACTOR (dB/m)
1	*2462.00	100.21 PK			1.44 H	144	69.87	30.34
2	*2462.00	90.72 AV			1.44 H	144	60.38	30.34
3	2483.50	53.63 PK	74.00	-20.37	1.32 H	65	23.20	30.43
4	2483.50	43.00 AV	54.00	-11.00	1.32 H	65	12.57	30.43
5	4924.00	48.90 PK	74.00	-25.10	1.09 H	360	13.27	35.63
6	4924.00	34.50 AV	54.00	-19.50	1.09 H	360	-1.13	35.63
7	7386.00	52.40 PK	74.00	-21.60	1.04 H	39	10.17	42.23
8	7386.00	38.30 AV	54.00	-15.70	1.04 H	39	-3.93	42.23
ANTENNA POLARITY & TEST DISTANCE: VERTICAL AT 3 M								
NO.	FREQ. (MHz)	EMISSION LEVEL (dBuV/m)	LIMIT (dBuV/m)	MARGIN (dB)	ANTENNA HEIGHT (m)	TABLE ANGLE (Degree)	RAW VALUE (dBuV)	CORRECTION FACTOR (dB/m)
1	*2462.00	121.57 PK			1.00 V	2	91.23	30.34
2	*2462.00	110.71 AV			1.00 V	2	80.37	30.34
3	2483.50	69.26 PK	74.00	-4.74	1.00 V	3	38.83	30.43
4	2483.50	52.89 AV	54.00	-1.11	1.00 V	3	22.46	30.43
5	4924.00	47.80 PK	74.00	-26.20	1.00 V	18	12.17	35.63
6	4924.00	33.92 AV	54.00	-20.08	1.00 V	18	-1.71	35.63
7	7386.00	57.47 PK	74.00	-16.53	1.12 V	85	15.24	42.23
8	7386.00	39.76 AV	54.00	-14.24	1.12 V	85	-2.47	42.23

- REMARKS:**
1. Emission level (dBuV/m) = Raw Value (dBuV) + Correction Factor (dB/m).
  2. Correction Factor (dB/m) = Antenna Factor (dB/m) + Cable Factor (dB).
  3. The other emission levels were very low against the limit.
  4. Margin value = Emission level – Limit value.
  5. “ \* “: Fundamental frequency.



A D T

### RESTRICTED BANDEDGE (802.11g MODE, CH1, HORIZONTAL )

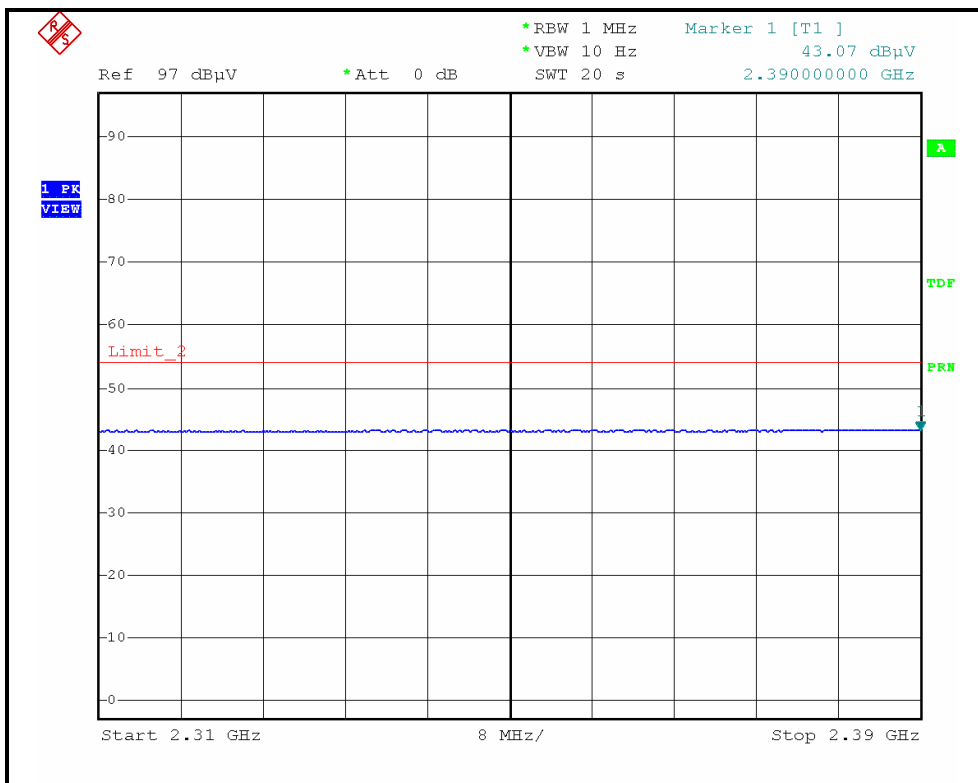
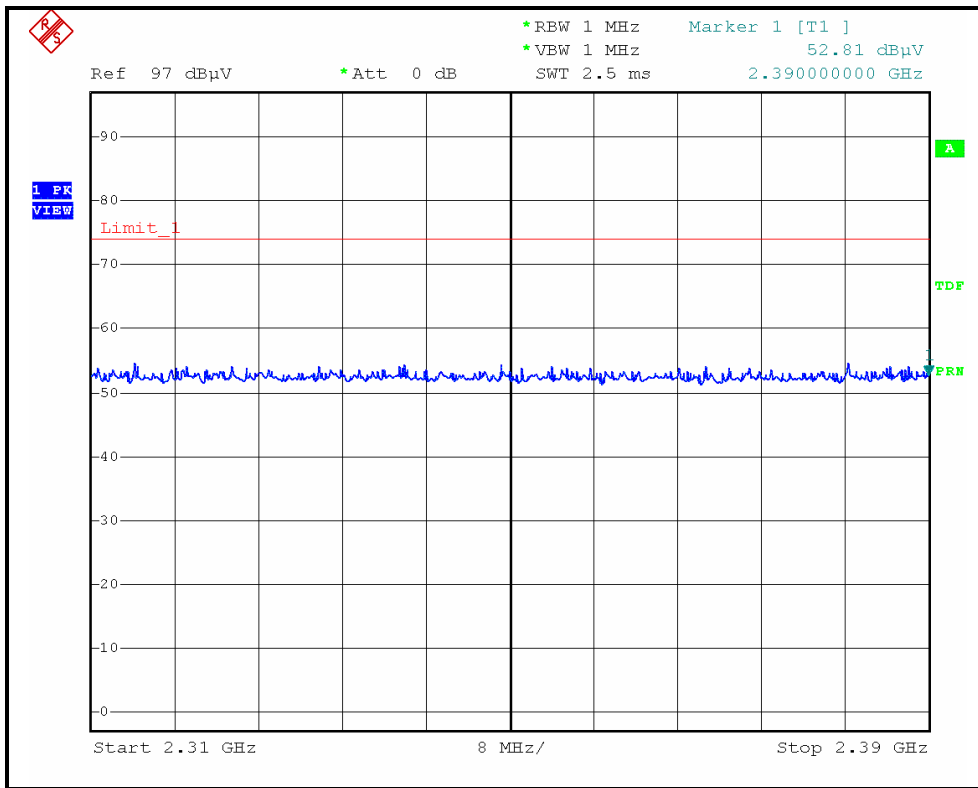



A D T

### RESTRICTED BANDEDGE (802.11g MODE,CH1, VERTICAL )

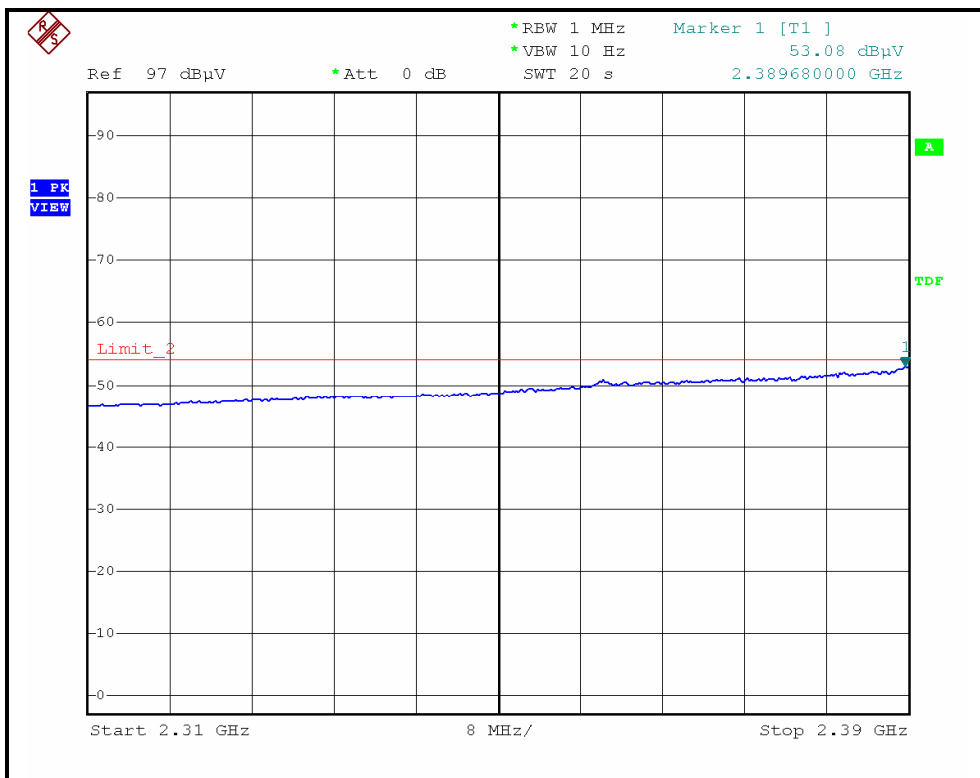
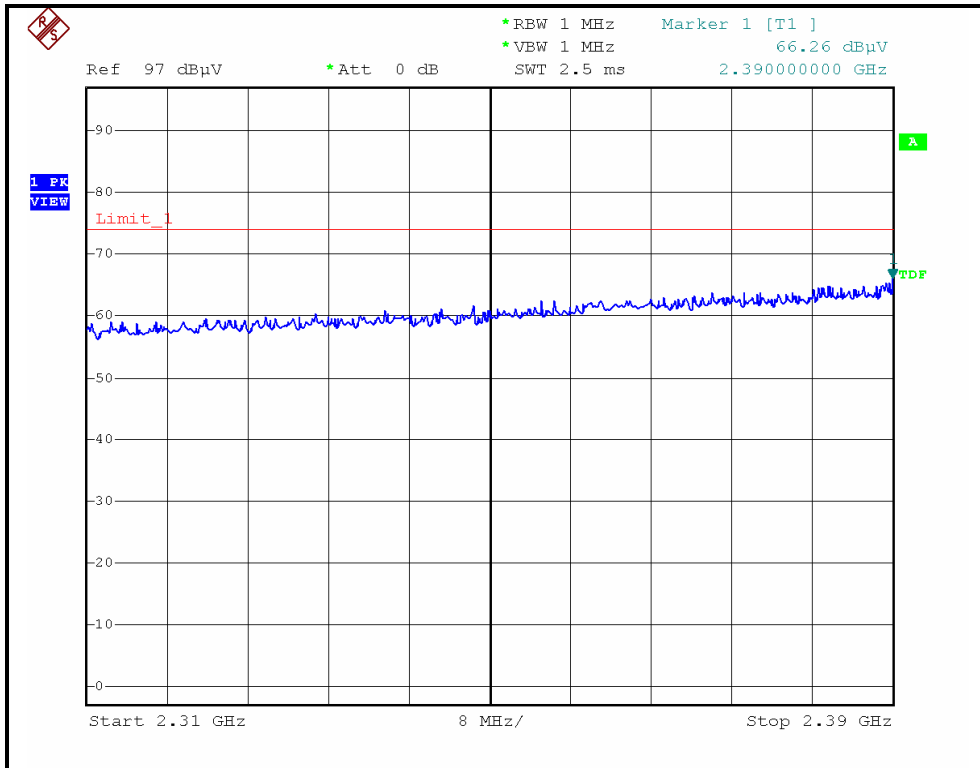



A D T

### RESTRICTED BANDEDGE (802.11g MODE,CH11, HORIZONTAL )

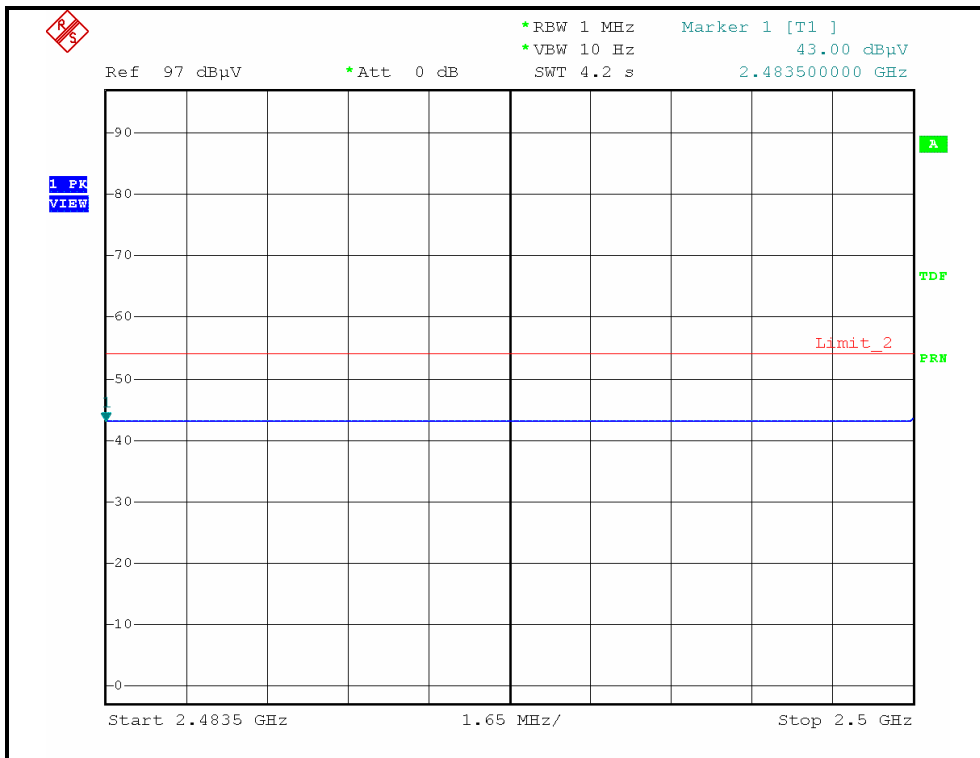
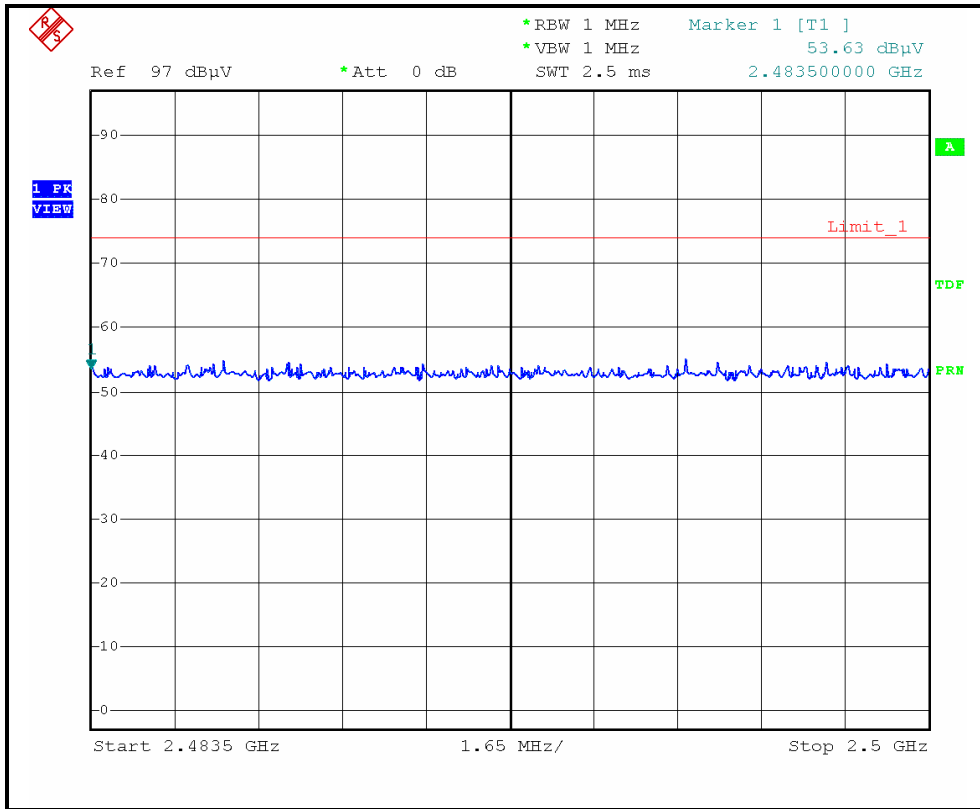



A D T

### RESTRICTED BANDEDGE (802.11g MODE,CH11, VERTICAL )

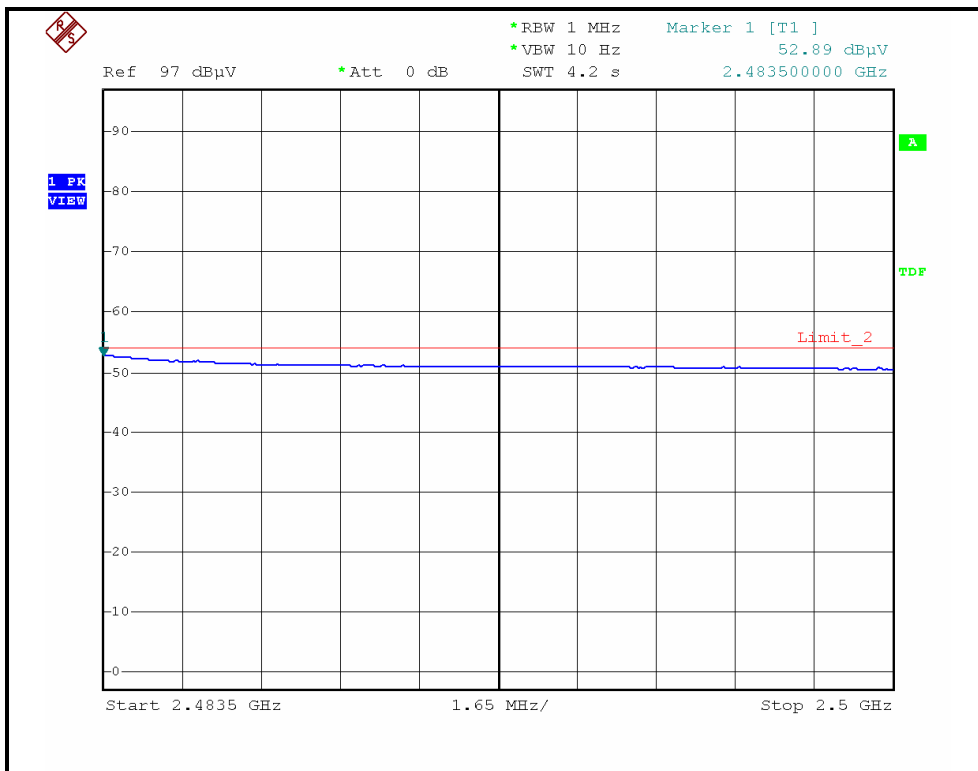
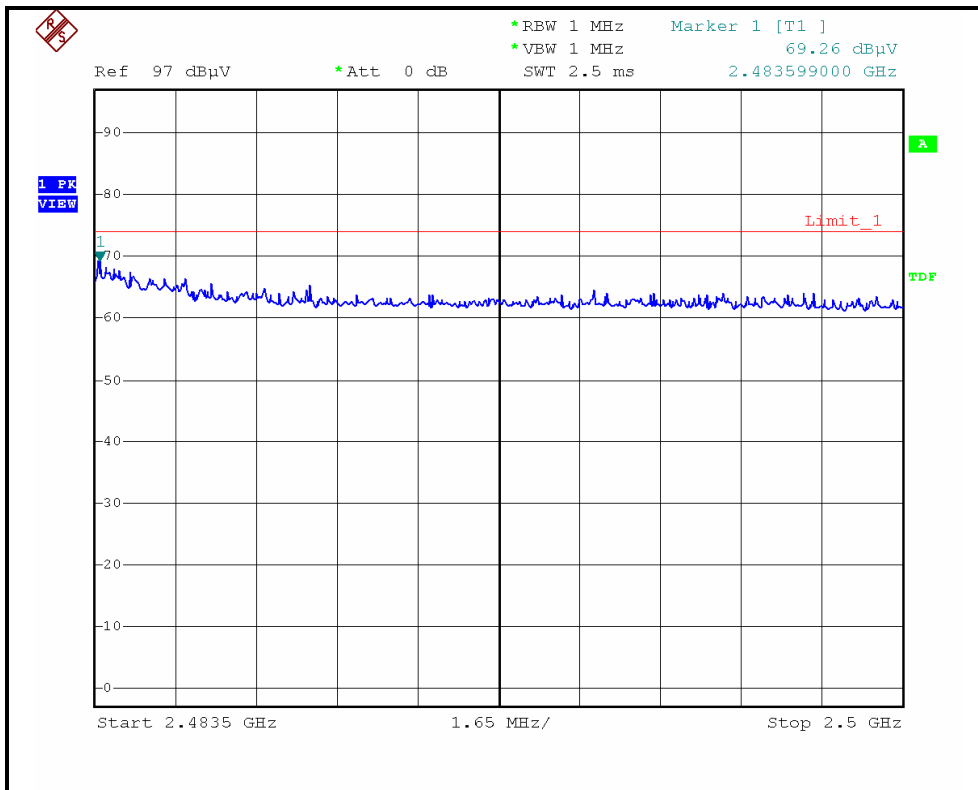



A D T

DRAFT 802.11n (20MHz) OFDM MODULATION

EUT TEST CONDITION		MEASUREMENT DETAIL	
CHANNEL	Channel 1	FREQUENCY RANGE	1 ~ 25GHz
INPUT POWER	120Vac, 60 Hz	DETECTOR FUNCTION	Peak (PK) Average (AV)
ENVIRONMENTAL CONDITIONS	30.0deg. C, 55.0%RH 965hPa	TESTED BY	Eric Lee

ANTENNA POLARITY & TEST DISTANCE: HORIZONTAL AT 3 M								
NO.	FREQ. (MHz)	EMISSION LEVEL (dBuV/m)	LIMIT (dBuV/m)	MARGIN (dB)	ANTENNA HEIGHT (m)	TABLE ANGLE (Degree)	RAW VALUE (dBuV)	CORRECTION FACTOR (dB/m)
1	2390.00	53.53 PK	74.00	-20.47	1.54 H	142	23.47	30.06
2	2390.00	42.59 AV	54.00	-11.41	1.54 H	142	12.53	30.06
3	*2412.00	101.10 PK			1.98 H	129	70.95	30.15
4	*2412.00	90.53 AV			1.98 H	129	60.38	30.15
5	4824.00	47.80 PK	74.00	-26.20	1.35 H	35	12.34	35.46
6	4824.00	33.90 AV	54.00	-20.10	1.35 H	35	-1.56	35.46
ANTENNA POLARITY & TEST DISTANCE: VERTICAL AT 3 M								
NO.	FREQ. (MHz)	EMISSION LEVEL (dBuV/m)	LIMIT (dBuV/m)	MARGIN (dB)	ANTENNA HEIGHT (m)	TABLE ANGLE (Degree)	RAW VALUE (dBuV)	CORRECTION FACTOR (dB/m)
1	2390.00	66.51 PK	74.00	-7.49	1.00 V	4	36.45	30.06
2	2390.00	53.16 AV	54.00	-0.84	1.00 V	4	23.10	30.06
3	*2412.00	121.17 PK			1.00 V	4	91.02	30.15
4	*2412.00	100.81 AV			1.00 V	4	70.66	30.15
5	4824.00	45.62 PK	74.00	-28.38	1.50 V	247	10.16	35.46
6	4824.00	33.87 AV	54.00	-20.13	1.50 V	247	-1.59	35.46

- REMARKS:**
1. Emission level (dBuV/m) = Raw Value (dBuV) + Correction Factor (dB/m).
  2. Correction Factor (dB/m) = Antenna Factor (dB/m) + Cable Factor (dB).
  3. The other emission levels were very low against the limit.
  4. Margin value = Emission level – Limit value.
  5. “ \* “: Fundamental frequency.





A D T

EUT TEST CONDITION		MEASUREMENT DETAIL	
CHANNEL	Channel 6	FREQUENCY RANGE	1 ~ 25GHz
INPUT POWER	120Vac, 60 Hz	DETECTOR FUNCTION	Peak (PK) Average (AV)
ENVIRONMENTAL CONDITIONS	30.0deg. C, 55.0%RH 965hPa	TESTED BY	Eric Lee

ANTENNA POLARITY & TEST DISTANCE: HORIZONTAL AT 3 M								
NO.	FREQ. (MHz)	EMISSION LEVEL (dBuV/m)	LIMIT (dBuV/m)	MARGIN (dB)	ANTENNA HEIGHT (m)	TABLE ANGLE (Degree)	RAW VALUE (dBuV)	CORRECTION FACTOR (dB/m)
1	*2437.00	101.20 PK			1.44 H	137	70.96	30.24
2	*2437.00	91.42 AV			1.44 H	137	61.18	30.24
3	2483.50	53.62 PK	74.00	-20.38	1.02 H	23	23.19	30.43
4	2483.50	43.14 AV	54.00	-10.86	1.02 H	23	12.71	30.43
5	4874.00	47.10 PK	74.00	-26.90	1.23 H	324	11.55	35.55
6	4874.00	33.60 AV	54.00	-20.40	1.23 H	324	-1.95	35.55
7	7311.00	53.80 PK	74.00	-20.20	1.36 H	95	11.76	42.04
8	7311.00	39.70 AV	54.00	-14.30	1.36 H	95	-2.34	42.04
ANTENNA POLARITY & TEST DISTANCE: VERTICAL AT 3 M								
NO.	FREQ. (MHz)	EMISSION LEVEL (dBuV/m)	LIMIT (dBuV/m)	MARGIN (dB)	ANTENNA HEIGHT (m)	TABLE ANGLE (Degree)	RAW VALUE (dBuV)	CORRECTION FACTOR (dB/m)
1	2390.00	64.10 PK	74.00	-9.90	1.00 V	11	34.04	30.06
2	2390.00	51.48 AV	54.00	-2.52	1.00 V	11	21.42	30.06
3	*2437.00	121.42 PK			1.00 V	358	91.18	30.24
4	*2437.00	111.05 AV			1.00 V	358	80.81	30.24
5	2483.50	65.45 PK	74.00	-8.55	1.00 V	359	35.02	30.43
6	2483.50	52.80 AV	54.00	-1.20	1.00 V	359	22.37	30.43
7	4874.00	47.97 PK	74.00	-26.03	1.02 V	24	12.42	35.55
8	4874.00	35.24 AV	54.00	-18.76	1.02 V	24	-0.31	35.55
9	7311.00	53.99 PK	74.00	-20.01	1.11 V	51	11.95	42.04
10	7311.00	39.87 AV	54.00	-14.13	1.11 V	51	-2.17	42.04

- REMARKS:**
1. Emission level (dBuV/m) = Raw Value (dBuV) + Correction Factor (dB/m).
  2. Correction Factor (dB/m) = Antenna Factor (dB/m) + Cable Factor (dB).
  3. The other emission levels were very low against the limit.
  4. Margin value = Emission level – Limit value.
  5. “ \* “: Fundamental frequency.



A D T

EUT TEST CONDITION		MEASUREMENT DETAIL	
CHANNEL	Channel 11	FREQUENCY RANGE	1 ~ 25GHz
INPUT POWER	120Vac, 60 Hz	DETECTOR FUNCTION	Peak (PK) Average (AV)
ENVIRONMENTAL CONDITIONS	30.0deg. C, 55.0%RH 965hPa	TESTED BY	Eric Lee

ANTENNA POLARITY & TEST DISTANCE: HORIZONTAL AT 3 M								
NO.	FREQ. (MHz)	EMISSION LEVEL (dBuV/m)	LIMIT (dBuV/m)	MARGIN (dB)	ANTENNA HEIGHT (m)	TABLE ANGLE (Degree)	RAW VALUE (dBuV)	CORRECTION FACTOR (dB/m)
1	*2462.00	100.20 PK			1.44 H	167	69.86	30.34
2	*2462.00	89.30 AV			1.44 H	167	58.96	30.34
3	2483.50	52.21 PK	74.00	-21.79	1.46 H	124	21.78	30.43
4	2483.50	43.05 AV	54.00	-10.95	1.46 H	124	12.62	30.43
5	4924.00	46.98 PK	74.00	-27.02	1.37 H	304	11.35	35.63
6	4924.00	33.72 AV	54.00	-20.28	1.37 H	304	-1.91	35.63
7	7386.00	53.18 PK	74.00	-20.82	1.06 H	58	10.95	42.23
8	7386.00	39.64 AV	54.00	-14.36	1.06 H	58	-2.59	42.23
ANTENNA POLARITY & TEST DISTANCE: VERTICAL AT 3 M								
NO.	FREQ. (MHz)	EMISSION LEVEL (dBuV/m)	LIMIT (dBuV/m)	MARGIN (dB)	ANTENNA HEIGHT (m)	TABLE ANGLE (Degree)	RAW VALUE (dBuV)	CORRECTION FACTOR (dB/m)
1	*2462.00	120.25 PK			1.00 V	5	89.91	30.34
2	*2462.00	109.61 AV			1.00 V	5	79.27	30.34
3	2483.50	70.73 PK	74.00	-3.27	1.00 V	2	40.30	30.43
4	2483.50	53.18 AV	54.00	-0.82	1.00 V	2	22.75	30.43
5	4924.00	47.65 PK	74.00	-26.35	1.00 V	38	12.02	35.63
6	4924.00	33.88 AV	54.00	-20.12	1.00 V	38	-1.75	35.63
7	7386.00	53.72 PK	74.00	-20.28	1.65 V	247	11.49	42.23
8	7386.00	39.65 AV	54.00	-14.35	1.65 V	247	-2.58	42.23

- REMARKS:**
1. Emission level (dBuV/m) = Raw Value (dBuV) + Correction Factor (dB/m).
  2. Correction Factor (dB/m) = Antenna Factor (dB/m) + Cable Factor (dB).
  3. The other emission levels were very low against the limit.
  4. Margin value = Emission level – Limit value.
  5. “ \* “: Fundamental frequency.



A D T

### RESTRICTED BANDEDGE (DRAFT 802.11n (20MHz) MODE, CH1, HORIZONTAL )

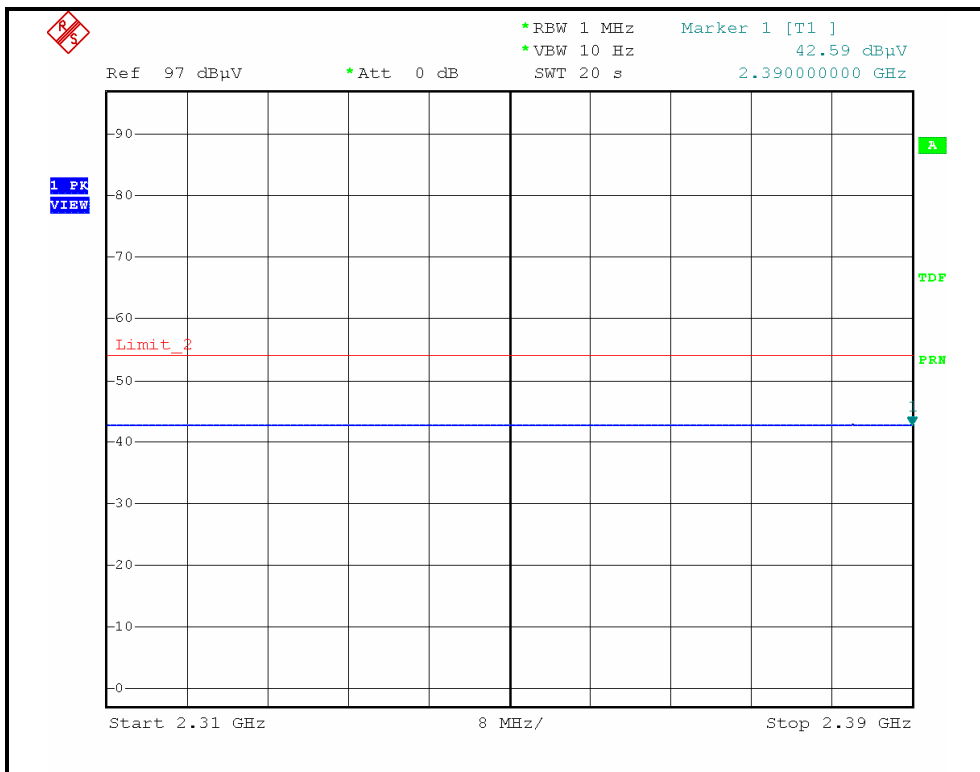
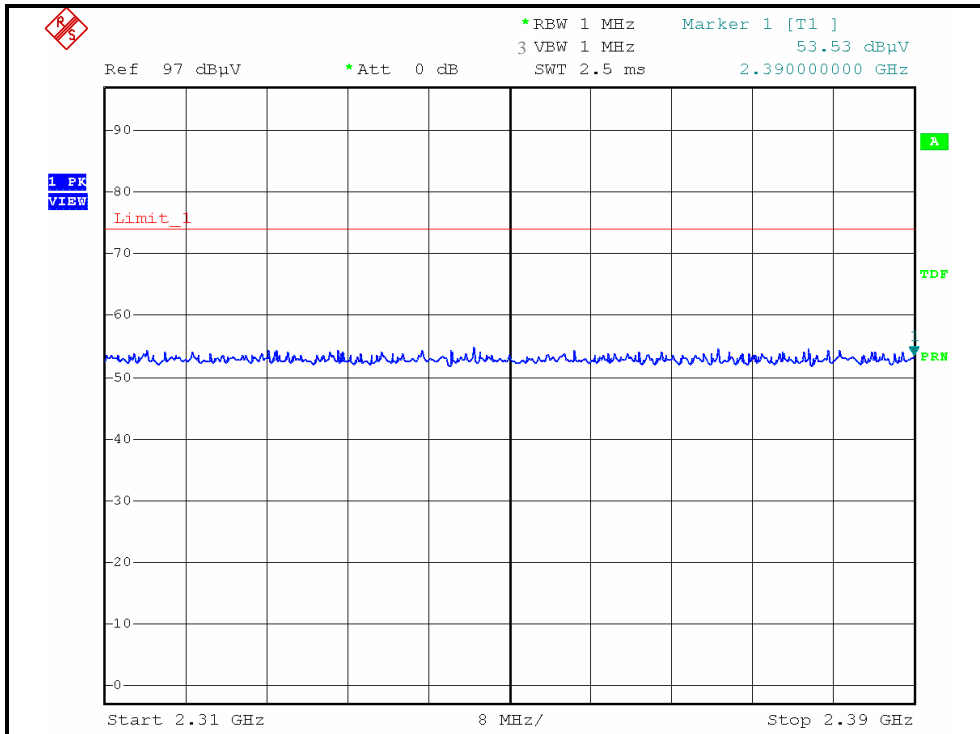



A D T

### RESTRICTED BANDEDGE (DRAFT 802.11n (20MHz) MODE,CH1, VERTICAL )

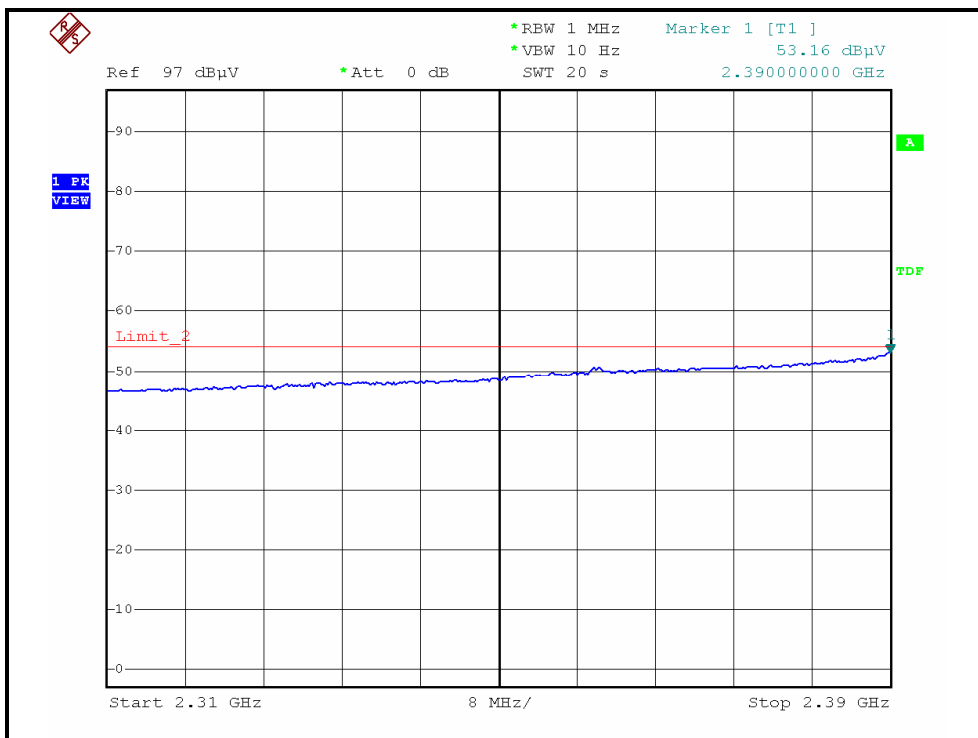
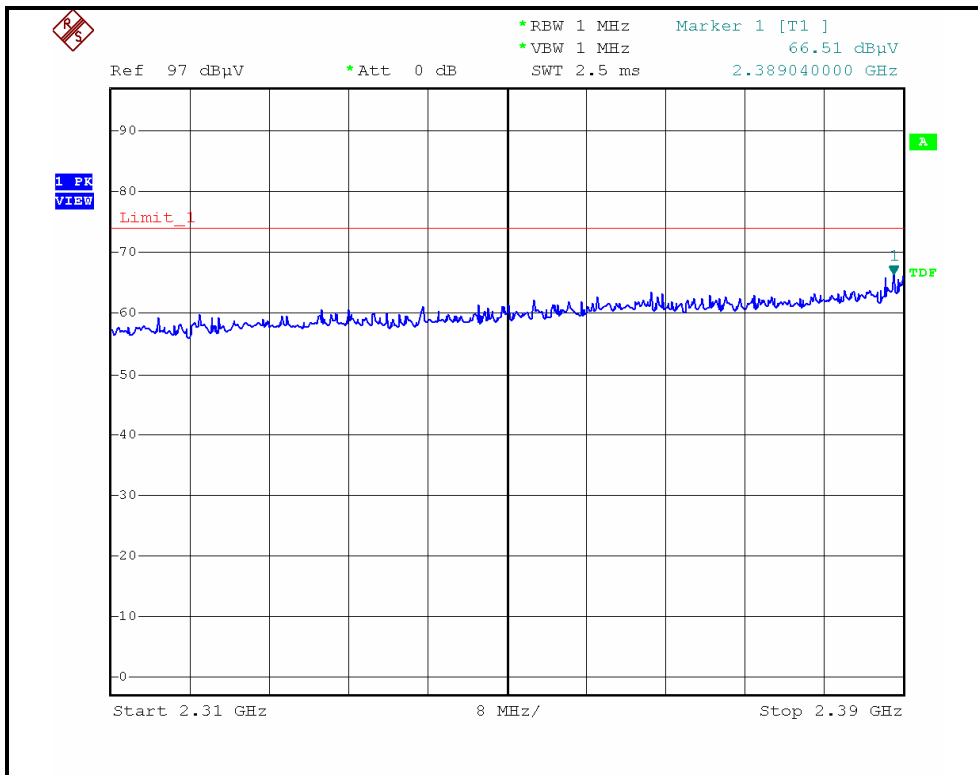



A D T

### RESTRICTED BANDEDGE (DRAFT 802.11n (20MHz) MODE, CH11, HORIZONTAL )

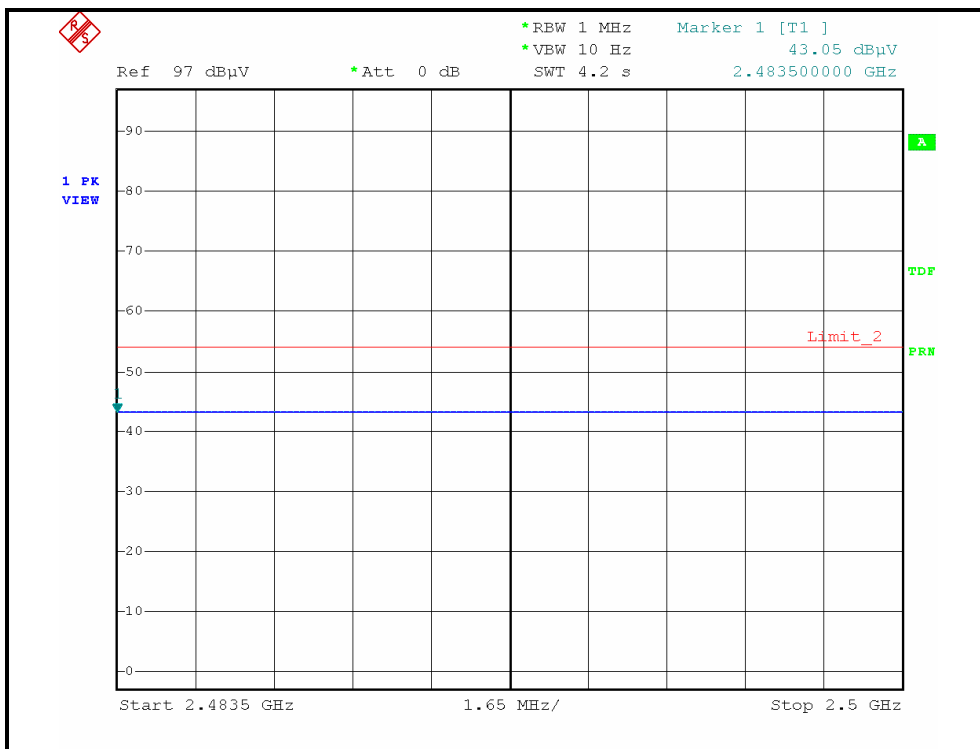
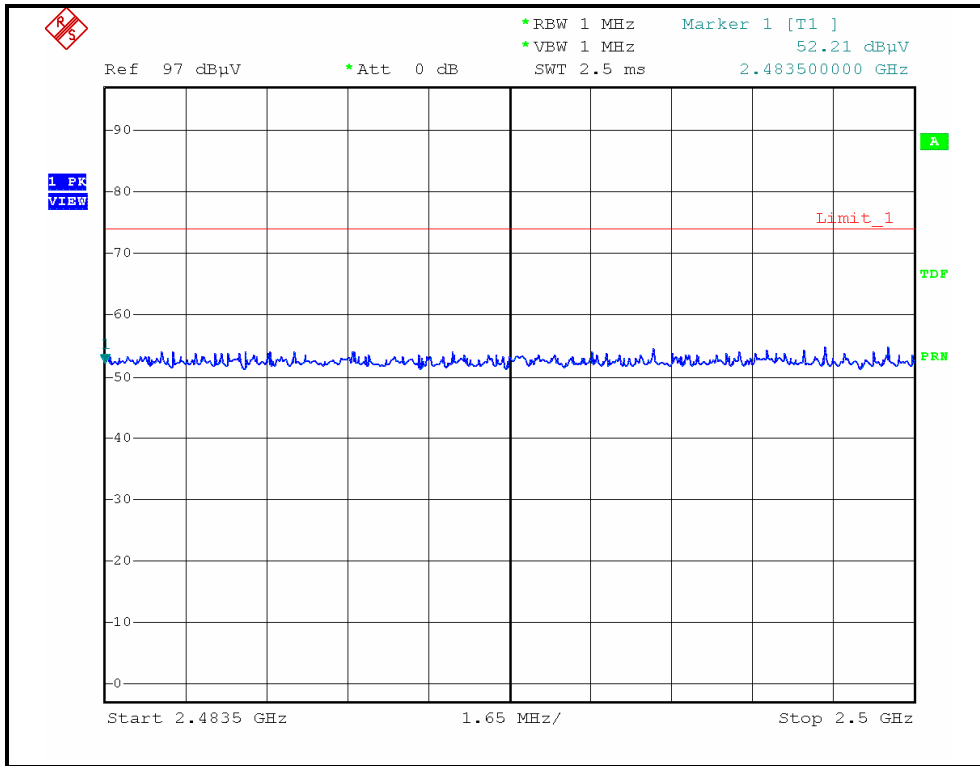



A D T

### RESTRICTED BANDEDGE (DRAFT 802.11n (20MHz) MODE,CH11, VERTICAL )

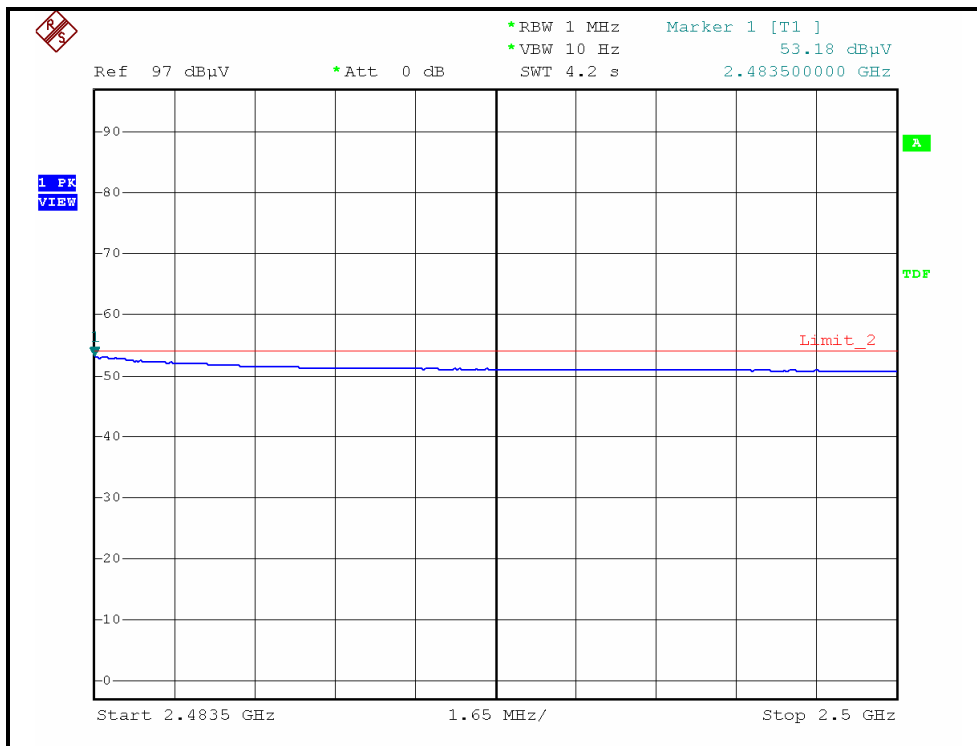
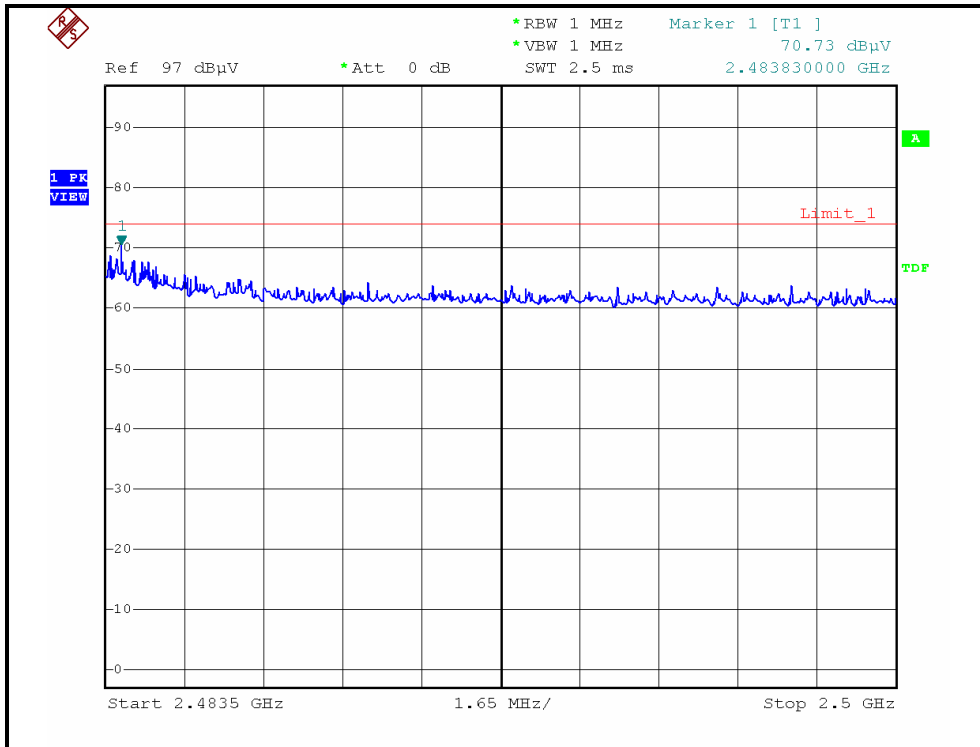



A D T

**DRAFT 802.11n (40MHz) OFDM MODULATION**

EUT TEST CONDITION		MEASUREMENT DETAIL	
CHANNEL	Channel 1	FREQUENCY RANGE	1 ~ 25GHz
INPUT POWER	120Vac, 60 Hz	DETECTOR FUNCTION	Peak (PK) Average (AV)
ENVIRONMENTAL CONDITIONS	30.0deg. C, 55.0%RH 965hPa	TESTED BY	Eric Lee

**ANTENNA POLARITY & TEST DISTANCE: HORIZONTAL AT 3 M**

NO.	FREQ. (MHz)	EMISSION LEVEL (dBuV/m)	LIMIT (dBuV/m)	MARGIN (dB)	ANTENNA HEIGHT (m)	TABLE ANGLE (Degree)	RAW VALUE (dBuV)	CORRECTION FACTOR (dB/m)
1	2390.00	57.17 PK	74.00	-16.83	1.57 H	360	27.11	30.06
2	2390.00	44.00 AV	54.00	-10.00	1.57 H	360	13.94	30.06
3	*2422.00	95.63 PK			1.57 H	195	65.44	30.19
4	*2422.00	84.57 AV			1.57 H	195	54.38	30.19
5	4844.00	48.20 PK	74.00	-25.80	1.23 H	65	12.70	35.50
6	4844.00	34.63 AV	54.00	-19.37	1.23 H	65	-0.87	35.50
7	7266.00	56.50 PK	74.00	-17.50	1.47 H	54	14.57	41.93
8	7266.00	41.20 AV	54.00	-12.80	1.47 H	54	-0.73	41.93

**ANTENNA POLARITY & TEST DISTANCE: VERTICAL AT 3 M**

NO.	FREQ. (MHz)	EMISSION LEVEL (dBuV/m)	LIMIT (dBuV/m)	MARGIN (dB)	ANTENNA HEIGHT (m)	TABLE ANGLE (Degree)	RAW VALUE (dBuV)	CORRECTION FACTOR (dB/m)
1	2390.00	73.20 PK	74.00	-0.80	1.00 V	4	43.14	30.06
2	2390.00	52.82 AV	54.00	-1.18	1.00 V	4	22.76	30.06
3	*2422.00	115.24 PK			1.00 V	3	85.05	30.19
4	*2422.00	104.24 AV			1.00 V	3	74.05	30.19
5	4844.00	47.75 PK	74.00	-26.25	1.02 V	5	12.25	35.50
6	4844.00	33.82 AV	54.00	-20.18	1.02 V	5	-1.68	35.50
7	7266.00	56.70 PK	74.00	-17.30	1.02 V	247	14.77	41.93
8	7266.00	41.60 AV	54.00	-12.40	1.02 V	247	-0.33	41.93

- REMARKS:**
1. Emission level (dBuV/m) = Raw Value (dBuV) + Correction Factor (dB/m).
  2. Correction Factor (dB/m) = Antenna Factor (dB/m) + Cable Factor (dB).
  3. The other emission levels were very low against the limit.
  4. Margin value = Emission level – Limit value.
  5. “ \* “: Fundamental frequency.



A D T

EUT TEST CONDITION		MEASUREMENT DETAIL	
CHANNEL	Channel 4	FREQUENCY RANGE	1 ~ 25GHz
INPUT POWER	120Vac, 60 Hz	DETECTOR FUNCTION	Peak (PK) Average (AV)
ENVIRONMENTAL CONDITIONS	30.0deg. C, 55.0%RH 965hPa	TESTED BY	Eric Lee

ANTENNA POLARITY & TEST DISTANCE: HORIZONTAL AT 3 M								
NO.	FREQ. (MHz)	EMISSION LEVEL (dBuV/m)	LIMIT (dBuV/m)	MARGIN (dB)	ANTENNA HEIGHT (m)	TABLE ANGLE (Degree)	RAW VALUE (dBuV)	CORRECTION FACTOR (dB/m)
1	*2437.00	95.87 PK			1.52 H	184	65.63	30.24
2	*2437.00	84.64 AV			1.52 H	184	54.40	30.24
3	2483.50	56.83 PK	74.00	-17.17	1.32 H	62	26.40	30.43
4	2483.50	43.84 AV	54.00	-10.16	1.32 H	62	13.41	30.43
5	4874.00	47.52 PK	74.00	-26.48	1.37 H	324	11.97	35.55
6	4874.00	33.58 AV	54.00	-20.42	1.37 H	324	-1.97	35.55
7	7311.00	53.12 PK	74.00	-20.88	1.82 H	72	11.08	42.04
8	7311.00	38.74 AV	54.00	-15.26	1.82 H	72	-3.30	42.04
ANTENNA POLARITY & TEST DISTANCE: VERTICAL AT 3 M								
NO.	FREQ. (MHz)	EMISSION LEVEL (dBuV/m)	LIMIT (dBuV/m)	MARGIN (dB)	ANTENNA HEIGHT (m)	TABLE ANGLE (Degree)	RAW VALUE (dBuV)	CORRECTION FACTOR (dB/m)
1	2390.00	64.32 PK	74.00	-9.68	1.00 V	9	34.26	30.06
2	2390.00	53.18 AV	54.00	-0.82	1.00 V	9	23.12	30.06
3	*2437.00	115.52 PK			1.00 V	4	85.28	30.24
4	*2437.00	104.81 AV			1.00 V	4	74.57	30.24
5	2483.50	65.49 PK	74.00	-8.51	1.00 V	3	35.06	30.43
6	2483.50	52.40 AV	54.00	-1.60	1.00 V	3	21.97	30.43
7	4874.00	47.63 PK	74.00	-26.37	1.24 V	51	12.08	35.55
8	4874.00	33.79 AV	54.00	-20.21	1.24 V	51	-1.76	35.55
9	7311.00	53.78 PK	74.00	-20.22	1.18 V	35	11.74	42.04
10	7311.00	39.65 AV	54.00	-14.35	1.18 V	35	-2.39	42.04

- REMARKS:**
1. Emission level (dBuV/m) = Raw Value (dBuV) + Correction Factor (dB/m).
  2. Correction Factor (dB/m) = Antenna Factor (dB/m) + Cable Factor (dB).
  3. The other emission levels were very low against the limit.
  4. Margin value = Emission level – Limit value.
  5. “ \* “: Fundamental frequency.





A D T

EUT TEST CONDITION		MEASUREMENT DETAIL	
CHANNEL	Channel 7	FREQUENCY RANGE	1 ~ 25GHz
INPUT POWER	120Vac, 60 Hz	DETECTOR FUNCTION	Peak (PK) Average (AV)
ENVIRONMENTAL CONDITIONS	30.0deg. C, 55.0%RH 965hPa	TESTED BY	Eric Lee

**ANTENNA POLARITY & TEST DISTANCE: HORIZONTAL AT 3 M**

NO.	FREQ. (MHz)	EMISSION LEVEL (dBuV/m)	LIMIT (dBuV/m)	MARGIN (dB)	ANTENNA HEIGHT (m)	TABLE ANGLE (Degree)	RAW VALUE (dBuV)	CORRECTION FACTOR (dB/m)
1	*2452.00	92.42 PK			1.50 H	184	62.12	30.30
2	*2452.00	82.45 AV			1.50 H	184	52.15	30.30
3	2483.50	54.30 PK	74.00	-19.70	1.48 H	137	23.87	30.43
4	2483.50	43.28 AV	54.00	-10.72	1.48 H	137	12.85	30.43
5	4904.00	46.93 PK	74.00	-27.07	1.32 H	331	11.33	35.60
6	4904.00	33.12 AV	54.00	-20.88	1.32 H	331	-2.48	35.60
7	7356.00	53.42 PK	74.00	-20.58	1.04 H	78	11.26	42.16
8	7356.00	39.37 AV	54.00	-14.63	1.04 H	78	-2.79	42.16

**ANTENNA POLARITY & TEST DISTANCE: VERTICAL AT 3 M**

NO.	FREQ. (MHz)	EMISSION LEVEL (dBuV/m)	LIMIT (dBuV/m)	MARGIN (dB)	ANTENNA HEIGHT (m)	TABLE ANGLE (Degree)	RAW VALUE (dBuV)	CORRECTION FACTOR (dB/m)
1	*2452.00	112.61 PK			1.00 V	3	82.10	30.51
2	*2452.00	102.11 AV			1.00 V	3	71.60	30.51
3	2483.50	72.42 PK	74.00	-1.58	1.00 V	3	41.79	30.63
4	2483.50	53.15 AV	54.00	-0.85	1.00 V	3	22.52	30.63
5	4904.00	47.45 PK	74.00	-26.55	1.03 V	62	10.45	37.00
6	4904.00	33.62 AV	54.00	-20.38	1.03 V	62	-3.38	37.00
7	7356.00	53.66 PK	74.00	-20.34	1.20 V	17	10.53	43.13
8	7356.00	39.82 AV	54.00	-14.18	1.20 V	17	-3.31	43.13

- REMARKS:**
1. Emission level (dBuV/m) = Raw Value (dBuV) + Correction Factor (dB/m).
  2. Correction Factor (dB/m) = Antenna Factor (dB/m) + Cable Factor (dB).
  3. The other emission levels were very low against the limit.
  4. Margin value = Emission level – Limit value.
  5. “ \* “: Fundamental frequency.



A D T

### RESTRICTED BANDEDGE (DRAFT 802.11n (40MHz) MODE, CH1, HORIZONTAL )

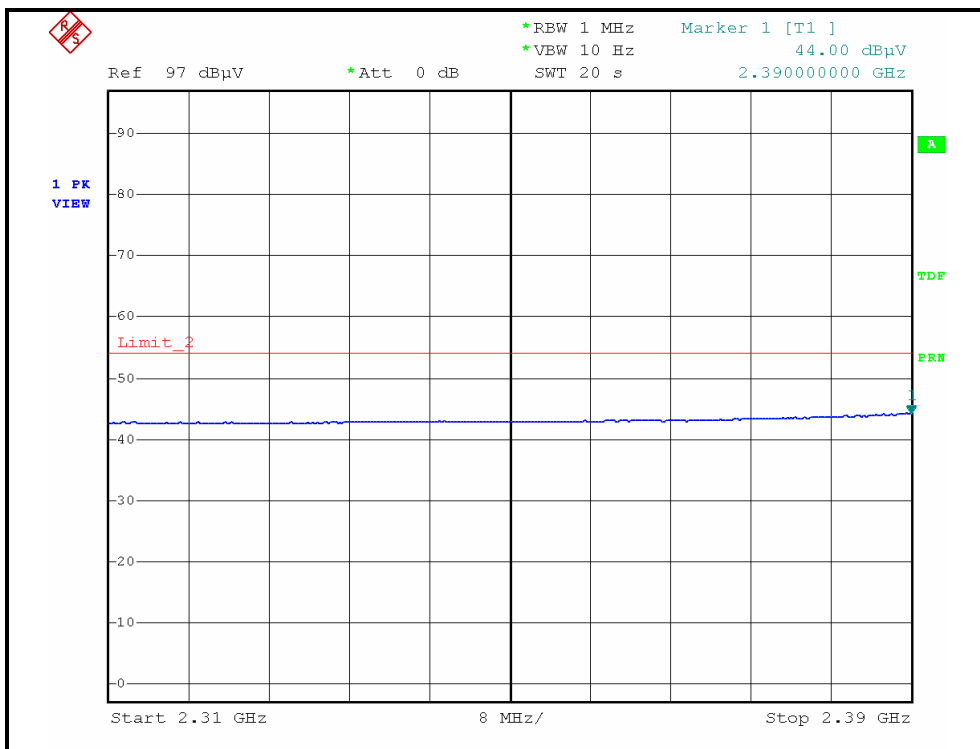
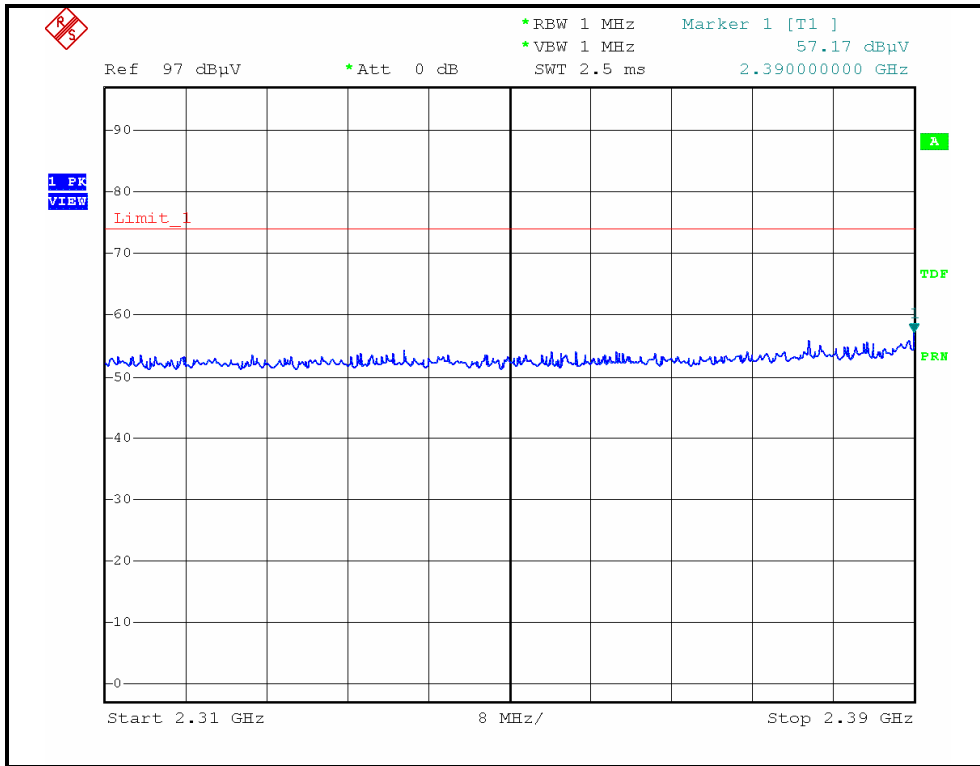



A D T

### RESTRICTED BANDEDGE (DRAFT 802.11n (40MHz) MODE,CH1, VERTICAL )

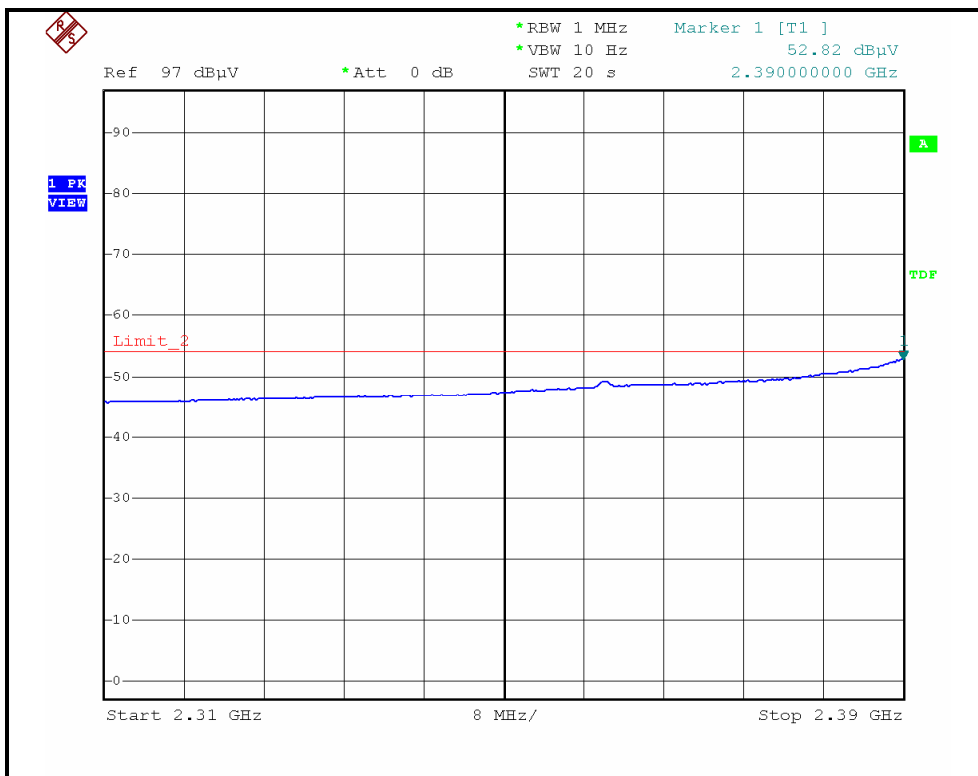
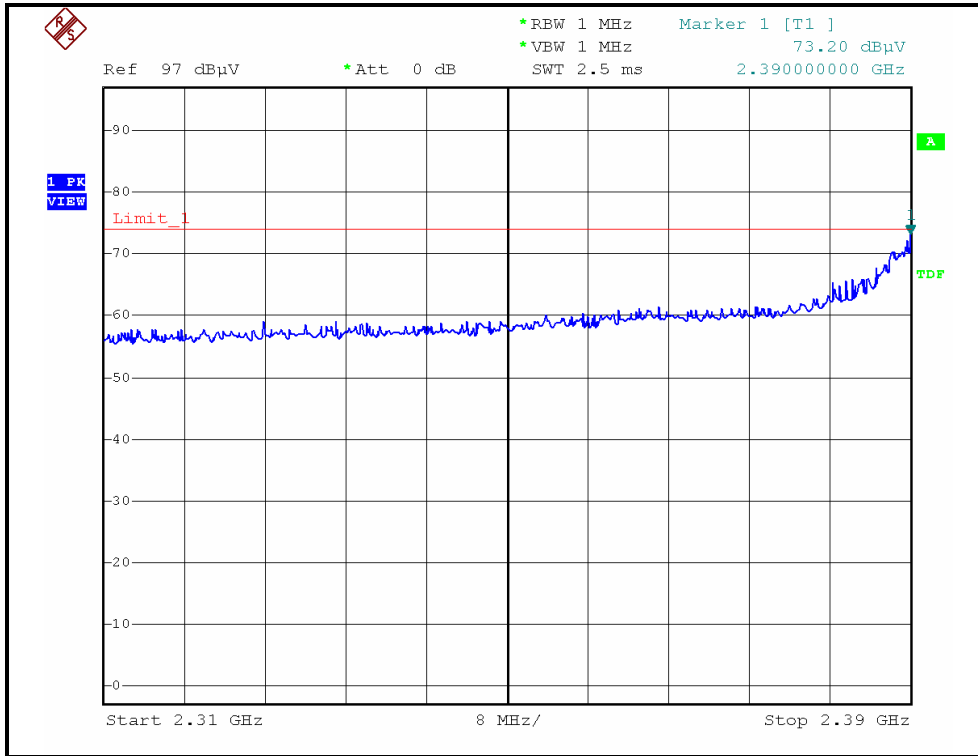



A D T

### RESTRICTED BANDEDGE (DRAFT 802.11n (40MHz) MODE,CH7, HORIZONTAL )

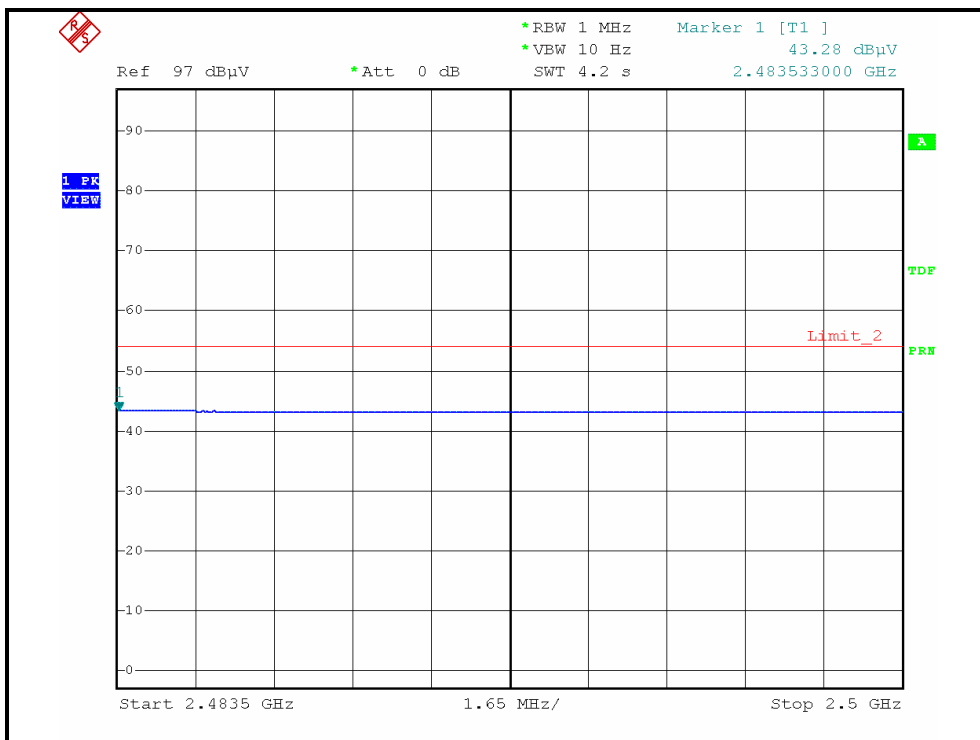
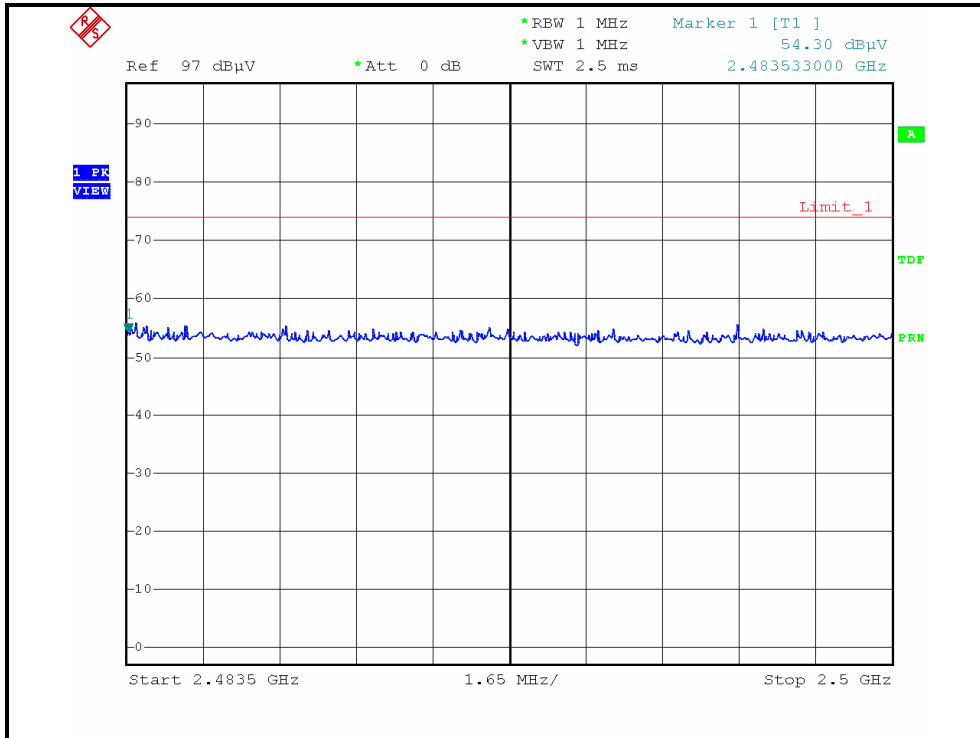



A D T

### RESTRICTED BANDEDGE (DRAFT 802.11n (40MHz) MODE,CH7, VERTICAL )

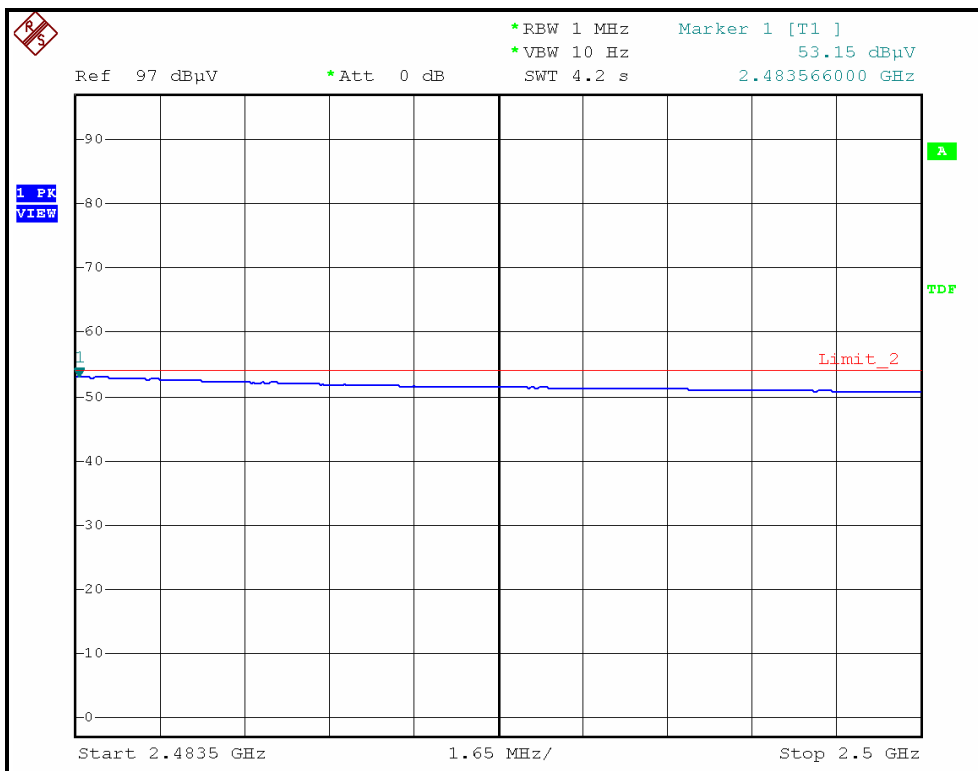
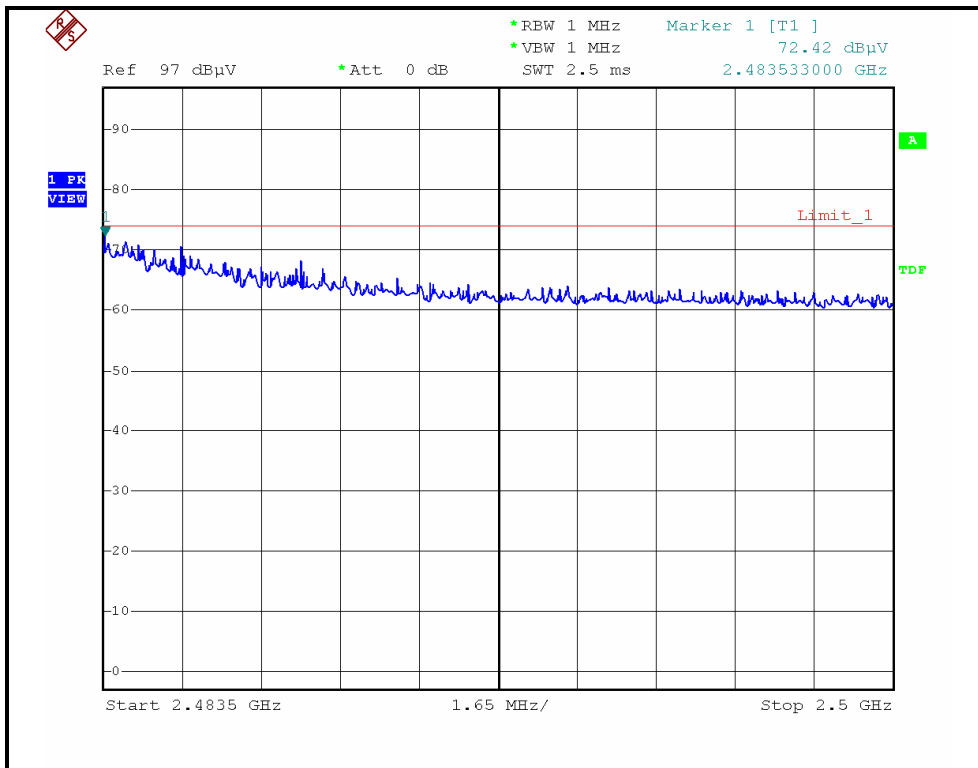



A D T

#### 4.2.9 TEST RESULTS –ANTENNA 4

#### BELOW 1GHz WORST-CASE DATA : 802.11b DSSS MODULATION

EUT TEST CONDITION		MEASUREMENT DETAIL	
CHANNEL	Channel 1	FREQUENCY RANGE	Below 1000MHz
INPUT POWER	120Vac, 60 Hz	DETECTOR FUNCTION	Quasi-Peak
ENVIRONMENTAL CONDITIONS	25.0deg. C, 72.0%RH 965hPa	TESTED BY	Frank Liu

ANTENNA POLARITY & TEST DISTANCE: HORIZONTAL AT 3 M								
NO.	FREQ. (MHz)	EMISSION LEVEL (dBuV/m)	LIMIT (dBuV/m)	MARGIN (dB)	ANTENNA HEIGHT (m)	TABLE ANGLE (Degree)	RAW VALUE (dBuV)	CORRECTION FACTOR (dB/m)
1	125.00	29.08 QP	43.50	-14.42	2.40 H	57	16.01	13.07
2	250.00	41.44 QP	46.00	-4.56	1.00 H	247	27.19	14.25
3	274.00	38.44 QP	46.00	-7.56	1.00 H	19	22.94	15.50
4	375.00	39.94 QP	46.00	-6.06	1.00 H	19	21.13	18.81
5	649.99	40.23 QP	46.00	-5.77	1.00 H	207	14.70	25.53
6	749.99	39.77 QP	46.00	-6.23	1.00 H	137	12.86	26.91
7	999.98	37.05 QP	54.00	-16.95	1.07 H	245	6.31	30.74

ANTENNA POLARITY & TEST DISTANCE: VERTICAL AT 3 M								
NO.	FREQ. (MHz)	EMISSION LEVEL (dBuV/m)	LIMIT (dBuV/m)	MARGIN (dB)	ANTENNA HEIGHT (m)	TABLE ANGLE (Degree)	RAW VALUE (dBuV)	CORRECTION FACTOR (dB/m)
1	44.96	32.17 QP	40.00	-7.83	1.00 V	167	17.38	14.79
2	132.00	27.03 QP	43.50	-16.47	1.13 V	276	13.24	13.79
3	250.00	34.59 QP	46.00	-11.41	1.00 V	64	20.34	14.25
4	650.00	36.23 QP	46.00	-9.77	1.00 V	267	10.70	25.53
5	875.00	35.69 QP	46.00	-10.31	1.00 V	253	6.40	29.29
6	999.98	37.06 QP	54.00	-16.94	1.00 V	126	6.32	30.74

- REMARKS:**
1. Emission level (dBuV/m) = Raw Value (dBuV) + Correction Factor (dB/m).
  2. Correction Factor (dB/m) = Antenna Factor (dB/m) + Cable Factor (dB).
  3. The other emission levels were very low against the limit.
  4. Margin value = Emission level – Limit value.



A D T

## ABOVE 1GHz WORST-CASE DATA

### 802.11b DSSS MODULATION

EUT TEST CONDITION		MEASUREMENT DETAIL	
CHANNEL	Channel 1	FREQUENCY RANGE	1 ~ 25GHz
INPUT POWER	120Vac, 60 Hz	DETECTOR FUNCTION	Peak (PK) Average (AV)
ENVIRONMENTAL CONDITIONS	30.0deg. C, 55.0%RH 965hPa	TESTED BY	Eric Lee

ANTENNA POLARITY & TEST DISTANCE: HORIZONTAL AT 3 M								
NO.	FREQ. (MHz)	EMISSION LEVEL (dBuV/m)	LIMIT (dBuV/m)	MARGIN (dB)	ANTENNA HEIGHT (m)	TABLE ANGLE (Degree)	RAW VALUE (dBuV)	CORRECTION FACTOR (dB/m)
1	2386.00	63.85 PK	74.00	-10.15	1.41 H	288	33.80	30.05
2	2386.00	53.36 AV	54.00	-0.64	1.41 H	288	23.31	30.05
3	*2412.00	119.60 PK			1.41 H	297	89.45	30.15
4	*2412.00	114.70 AV			1.41 H	297	84.55	30.15
5	4824.00	52.00 PK	74.00	-22.00	1.04 H	317	16.54	35.46
6	4824.00	46.27 AV	54.00	-7.73	1.04 H	317	10.81	35.46
ANTENNA POLARITY & TEST DISTANCE: VERTICAL AT 3 M								
NO.	FREQ. (MHz)	EMISSION LEVEL (dBuV/m)	LIMIT (dBuV/m)	MARGIN (dB)	ANTENNA HEIGHT (m)	TABLE ANGLE (Degree)	RAW VALUE (dBuV)	CORRECTION FACTOR (dB/m)
1	2386.00	59.66 PK	74.00	-14.34	1.20 V	199	29.61	30.05
2	2386.00	51.73 AV	54.00	-2.27	1.20 V	199	21.68	30.05
3	*2412.00	118.20 PK			1.21 V	178	88.05	30.15
4	*2412.00	113.40 AV			1.21 V	178	83.25	30.15
5	4824.00	55.45 PK	74.00	-18.55	1.51 V	20	19.99	35.46
6	4824.00	51.15 AV	54.00	-2.85	1.51 V	20	15.69	35.46

- REMARKS:**
1. Emission level (dBuV/m) = Raw Value (dBuV) + Correction Factor (dB/m).
  2. Correction Factor (dB/m) = Antenna Factor (dB/m) + Cable Factor (dB).
  3. The other emission levels were very low against the limit.
  4. Margin value = Emission level – Limit value.
  5. “ \* “: Fundamental frequency.



A D T

EUT TEST CONDITION		MEASUREMENT DETAIL	
CHANNEL	Channel 6	FREQUENCY RANGE	1 ~ 25GHz
INPUT POWER	120Vac, 60 Hz	DETECTOR FUNCTION	Peak (PK) Average (AV)
ENVIRONMENTAL CONDITIONS	30.0deg. C, 55.0%RH 965hPa	TESTED BY	Eric Lee

**ANTENNA POLARITY & TEST DISTANCE: HORIZONTAL AT 3 M**

NO.	FREQ. (MHz)	EMISSION LEVEL (dBuV/m)	LIMIT (dBuV/m)	MARGIN (dB)	ANTENNA HEIGHT (m)	TABLE ANGLE (Degree)	RAW VALUE (dBuV)	CORRECTION FACTOR (dB/m)
1	2390.00	58.48 PK	74.00	-15.52	1.43 H	295	28.42	30.06
2	2390.00	46.35 AV	54.00	-7.65	1.43 H	295	16.29	30.06
3	*2437.00	116.43 PK			1.42 H	293	86.19	30.24
4	*2437.00	112.19 AV			1.42 H	293	81.95	30.24
5	2483.50	59.00 PK	74.00	-15.00	1.43 H	276	28.57	30.43
6	2483.50	46.13 AV	54.00	-7.87	1.43 H	276	15.70	30.43
7	4874.00	53.25 PK	74.00	-20.75	1.55 H	3	17.70	35.55
8	4874.00	47.87 AV	54.00	-6.13	1.55 H	3	12.32	35.55
9	7311.00	56.63 PK	74.00	-17.37	1.25 H	47	14.59	42.04
10	7311.00	46.18 AV	54.00	-7.82	1.25 H	47	4.14	42.04

**ANTENNA POLARITY & TEST DISTANCE: VERTICAL AT 3 M**

NO.	FREQ. (MHz)	EMISSION LEVEL (dBuV/m)	LIMIT (dBuV/m)	MARGIN (dB)	ANTENNA HEIGHT (m)	TABLE ANGLE (Degree)	RAW VALUE (dBuV)	CORRECTION FACTOR (dB/m)
1	*2437.00	115.40 PK			1.24 V	174	85.16	30.24
2	*2437.00	111.60 AV			1.24 V	174	81.36	30.24
3	4874.00	56.36 PK	74.00	-17.64	1.52 V	27	20.81	35.55
4	4874.00	52.83 AV	54.00	-1.17	1.52 V	27	17.28	35.55
5	7311.00	56.08 PK	74.00	-17.92	1.83 V	20	14.04	42.04
6	7311.00	45.14 AV	54.00	-8.86	1.83 V	20	3.10	42.04

- REMARKS:**
1. Emission level (dBuV/m) = Raw Value (dBuV) + Correction Factor (dB/m).
  2. Correction Factor (dB/m) = Antenna Factor (dB/m) + Cable Factor (dB).
  3. The other emission levels were very low against the limit.
  4. Margin value = Emission level – Limit value.
  5. “ \* “: Fundamental frequency.





A D T

EUT TEST CONDITION		MEASUREMENT DETAIL	
CHANNEL	Channel 11	FREQUENCY RANGE	1 ~ 25GHz
INPUT POWER	120Vac, 60 Hz	DETECTOR FUNCTION	Peak (PK) Average (AV)
ENVIRONMENTAL CONDITIONS	30.0deg. C, 55.0%RH 965hPa	TESTED BY	Eric Lee

ANTENNA POLARITY & TEST DISTANCE: HORIZONTAL AT 3 M								
NO.	FREQ. (MHz)	EMISSION LEVEL (dBuV/m)	LIMIT (dBuV/m)	MARGIN (dB)	ANTENNA HEIGHT (m)	TABLE ANGLE (Degree)	RAW VALUE (dBuV)	CORRECTION FACTOR (dB/m)
1	*2462.00	116.20 PK			1.42 H	296	85.86	30.34
2	*2462.00	111.53 AV			1.42 H	296	81.19	30.34
3	2487.00	63.90 PK	74.00	-10.10	1.43 H	298	33.46	30.44
4	2487.00	51.96 AV	54.00	-2.04	1.43 H	298	21.52	30.44
5	4924.00	51.89 PK	74.00	-22.11	1.12 H	106	16.26	35.63
6	4924.00	46.37 AV	54.00	-7.63	1.12 H	106	10.74	35.63
7	7386.00	55.21 PK	74.00	-18.79	1.53 H	257	12.98	42.23
8	7386.00	43.49 AV	54.00	-10.51	1.53 H	257	1.26	42.23
ANTENNA POLARITY & TEST DISTANCE: VERTICAL AT 3 M								
NO.	FREQ. (MHz)	EMISSION LEVEL (dBuV/m)	LIMIT (dBuV/m)	MARGIN (dB)	ANTENNA HEIGHT (m)	TABLE ANGLE (Degree)	RAW VALUE (dBuV)	CORRECTION FACTOR (dB/m)
1	*2462.00	115.70 PK			1.24 V	157	85.36	30.34
2	*2462.00	110.80 AV			1.24 V	157	80.46	30.34
3	2488.60	58.04 PK	74.00	-15.96	1.20 V	101	27.59	30.45
4	2488.60	50.09 AV	54.00	-3.91	1.20 V	101	19.64	30.45
5	4924.00	55.73 PK	74.00	-18.27	1.47 V	14	20.10	35.63
6	4924.00	52.27 AV	54.00	-1.73	1.47 V	14	16.64	35.63
7	7386.00	55.53 PK	74.00	-18.47	2.02 V	21	13.30	42.23
8	7386.00	43.07 AV	54.00	-10.93	2.02 V	21	0.84	42.23

- REMARKS:**
1. Emission level (dBuV/m) = Raw Value (dBuV) + Correction Factor (dB/m).
  2. Correction Factor (dB/m) = Antenna Factor (dB/m) + Cable Factor (dB).
  3. The other emission levels were very low against the limit.
  4. Margin value = Emission level – Limit value.
  5. “ \* “: Fundamental frequency.



A D T

### RESTRICTED BANDEDGE (802.11b MODE,CH1, HORIZONTAL )

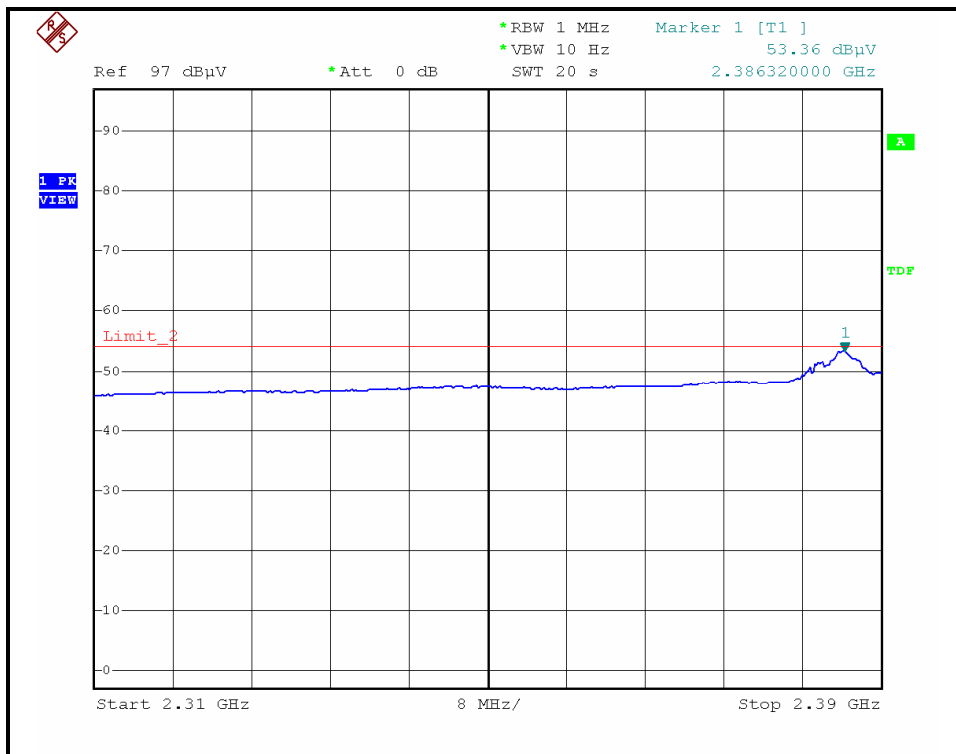
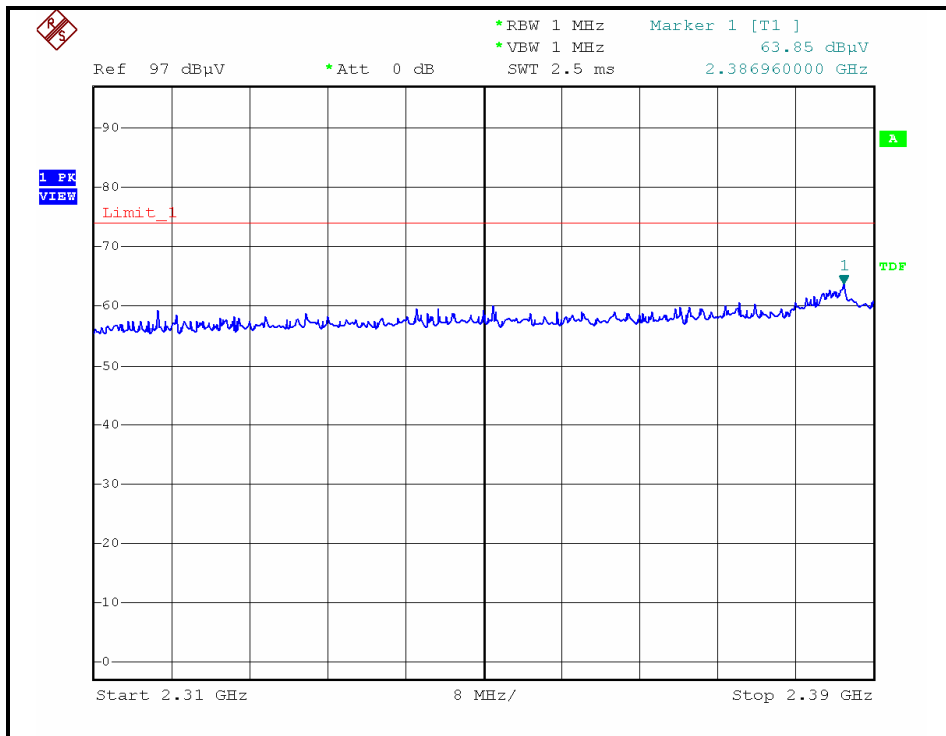



A D T

### RESTRICTED BANDEDGE (802.11b MODE, CH1, VERTICAL )

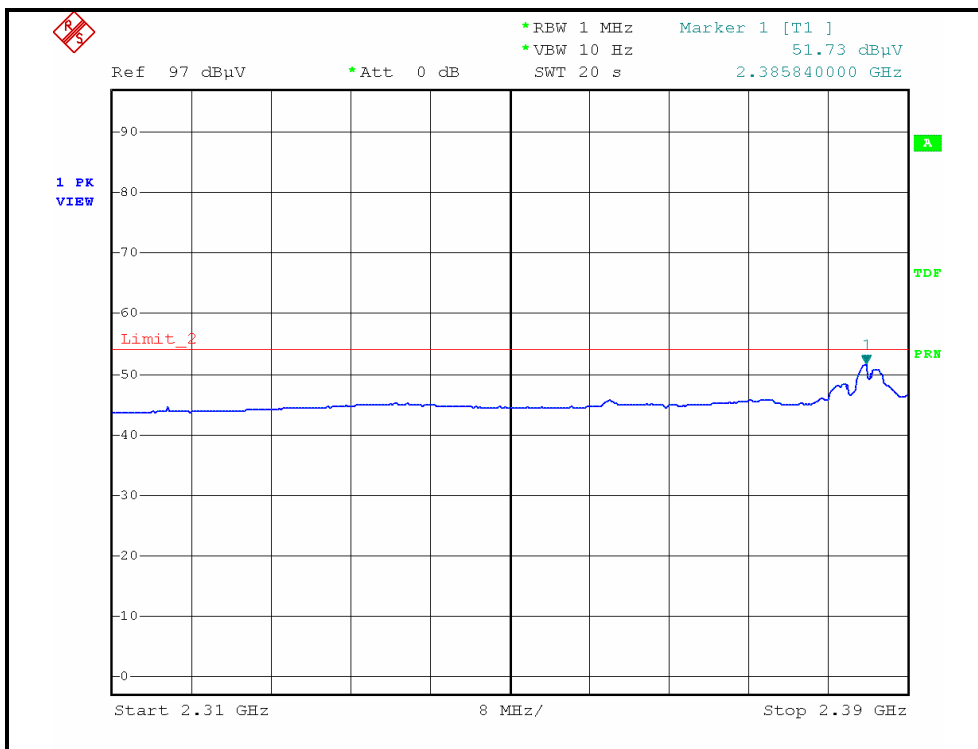
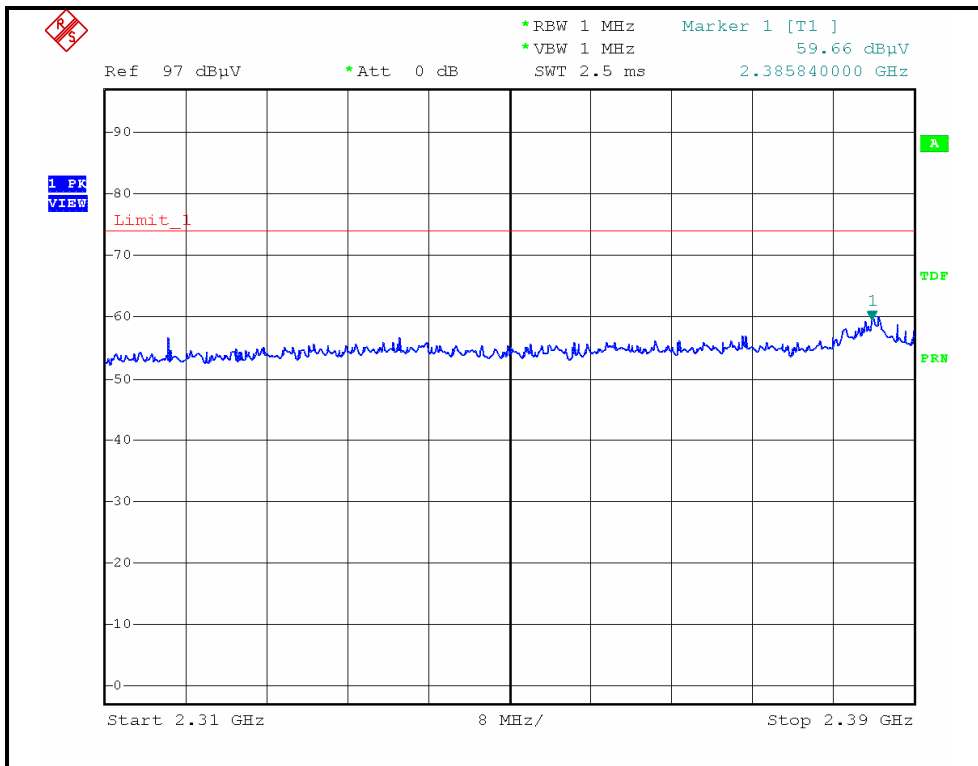



A D T

### RESTRICTED BANDEDGE (802.11b MODE,CH11, HORIZONTAL )

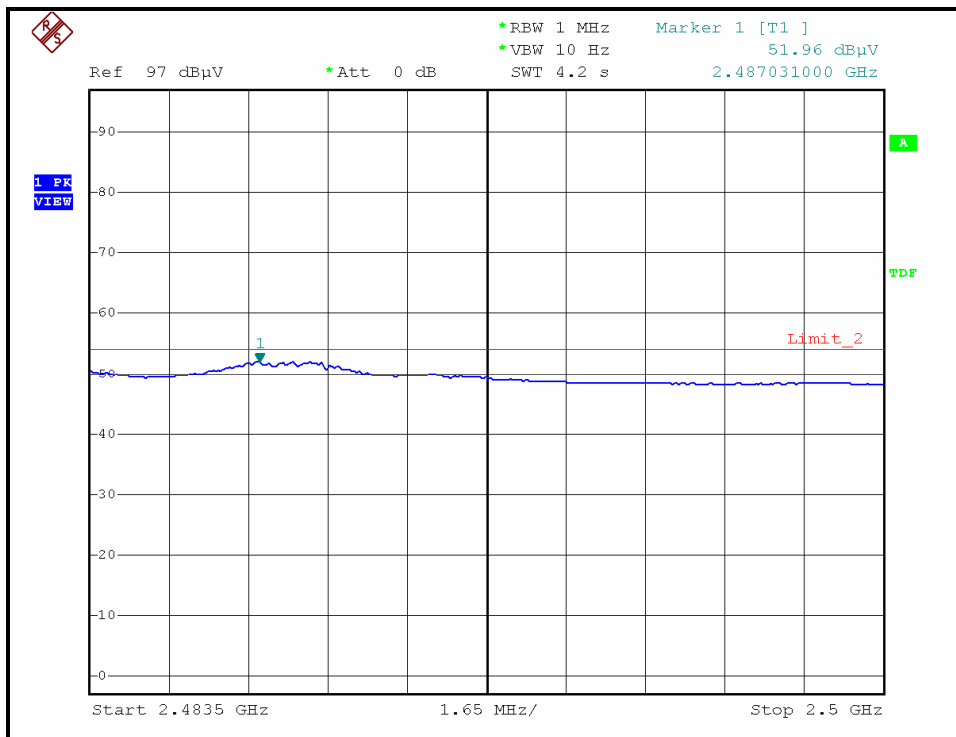
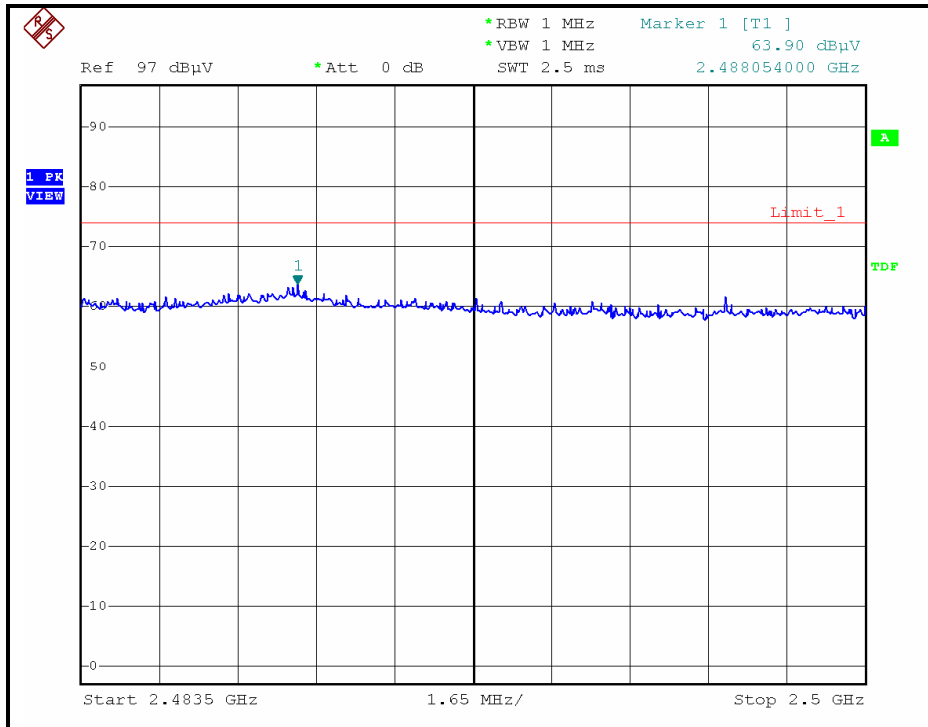



A D T

### RESTRICTED BANDEDGE (802.11b MODE, CH11, VERTICAL)

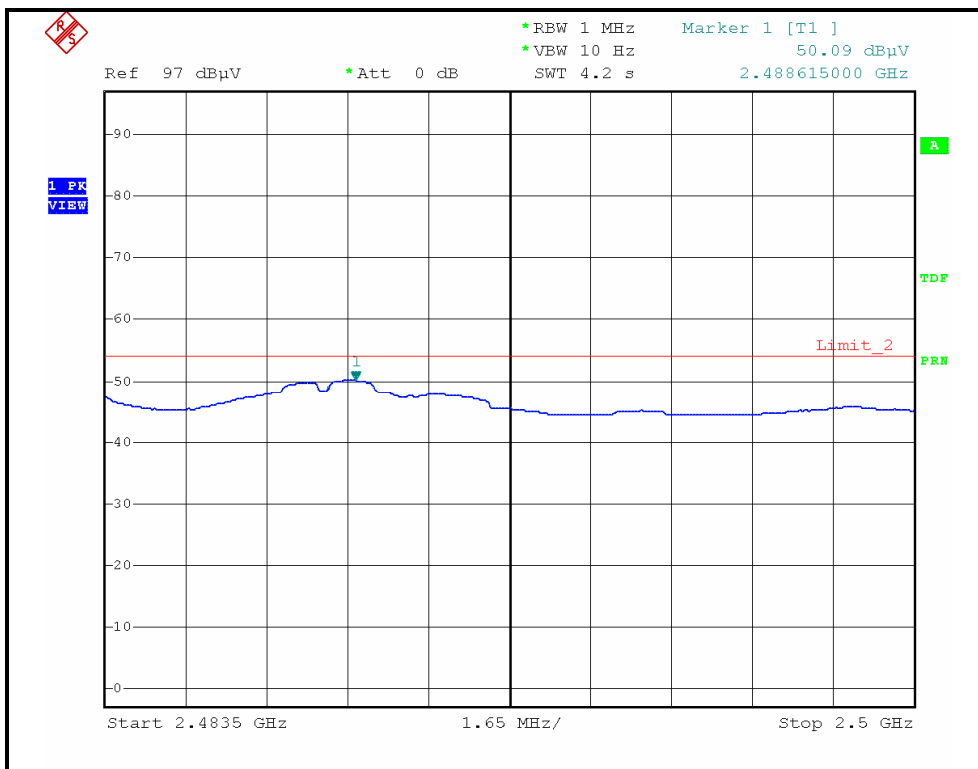
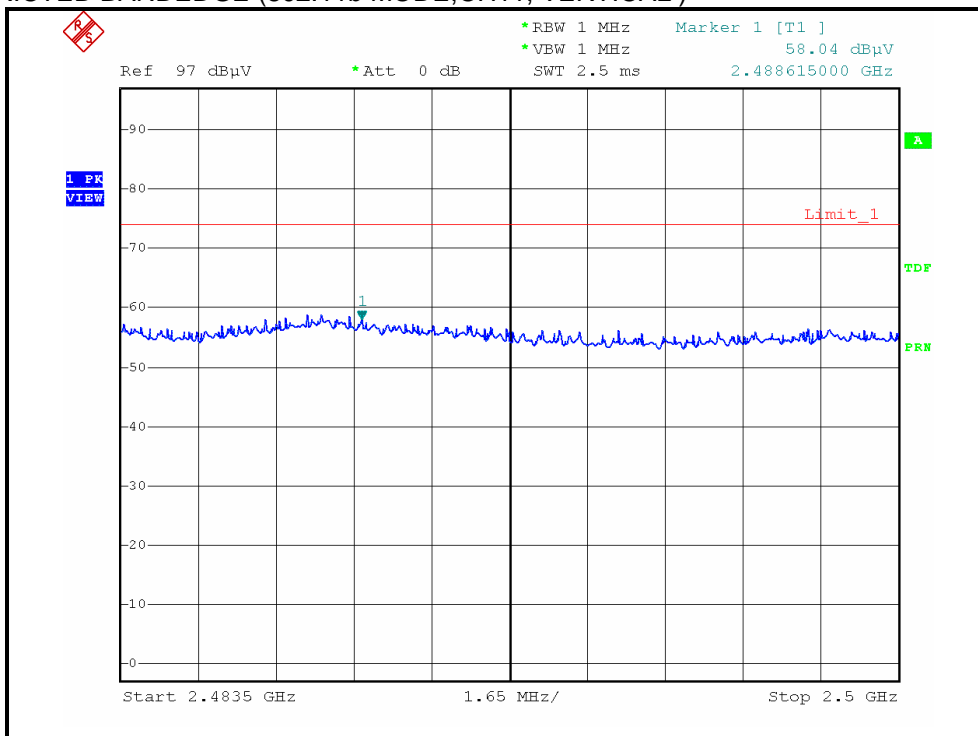



A D T

**802.11g OFDM MODULATION**

EUT TEST CONDITION		MEASUREMENT DETAIL	
CHANNEL	Channel 1	FREQUENCY RANGE	1 ~ 25GHz
INPUT POWER	120Vac, 60 Hz	DETECTOR FUNCTION	Peak (PK) Average (AV)
ENVIRONMENTAL CONDITIONS	30.0deg. C, 55.0%RH 965hPa	TESTED BY	Eric Lee

ANTENNA POLARITY & TEST DISTANCE: HORIZONTAL AT 3 M								
NO.	FREQ. (MHz)	EMISSION LEVEL (dBuV/m)	LIMIT (dBuV/m)	MARGIN (dB)	ANTENNA HEIGHT (m)	TABLE ANGLE (Degree)	RAW VALUE (dBuV)	CORRECTION FACTOR (dB/m)
1	2390.00	66.44 PK	74.00	-7.56	1.41 H	293	36.38	30.06
2	2390.00	52.11 AV	54.00	-1.89	1.41 H	293	22.05	30.06
3	*2412.00	118.10 PK			1.41 H	292	87.95	30.15
4	*2412.00	106.30 AV			1.41 H	292	76.15	30.15
5	4824.00	47.40 PK	74.00	-26.60	1.05 H	322	11.94	35.46
6	4824.00	33.70 AV	54.00	-20.30	1.05 H	322	-1.76	35.46
ANTENNA POLARITY & TEST DISTANCE: VERTICAL AT 3 M								
NO.	FREQ. (MHz)	EMISSION LEVEL (dBuV/m)	LIMIT (dBuV/m)	MARGIN (dB)	ANTENNA HEIGHT (m)	TABLE ANGLE (Degree)	RAW VALUE (dBuV)	CORRECTION FACTOR (dB/m)
1	2390.00	65.40 PK	74.00	-8.60	1.20 V	198	35.34	30.06
2	2390.00	50.11 AV	54.00	-3.89	1.20 V	198	20.05	30.06
3	*2412.00	117.20 PK			1.21 V	184	87.05	30.15
4	*2412.00	105.10 AV			1.21 V	184	74.95	30.15
5	4824.00	55.60 PK	74.00	-18.40	1.47 V	29	20.14	35.46
6	4824.00	40.80 AV	54.00	-13.20	1.47 V	29	5.34	35.46

- REMARKS:**
1. Emission level (dBuV/m) = Raw Value (dBuV) + Correction Factor (dB/m).
  2. Correction Factor (dB/m) = Antenna Factor (dB/m) + Cable Factor (dB).
  3. The other emission levels were very low against the limit.
  4. Margin value = Emission level – Limit value.
  5. “ \* “: Fundamental frequency.



A D T

EUT TEST CONDITION		MEASUREMENT DETAIL	
CHANNEL	Channel 6	FREQUENCY RANGE	1 ~ 25GHz
INPUT POWER	120Vac, 60 Hz	DETECTOR FUNCTION	Peak (PK) Average (AV)
ENVIRONMENTAL CONDITIONS	30.0deg. C, 55.0%RH 965hPa	TESTED BY	Eric Lee

ANTENNA POLARITY & TEST DISTANCE: HORIZONTAL AT 3 M								
NO.	FREQ. (MHz)	EMISSION LEVEL (dBuV/m)	LIMIT (dBuV/m)	MARGIN (dB)	ANTENNA HEIGHT (m)	TABLE ANGLE (Degree)	RAW VALUE (dBuV)	CORRECTION FACTOR (dB/m)
1	2390.00	60.00 PK	74.00	-14.00	1.41 H	292	29.94	30.06
2	2390.00	48.21 AV	54.00	-5.79	1.41 H	292	18.15	30.06
3	*2437.00	114.62 PK			1.43 H	297	84.38	30.24
4	*2437.00	104.85 AV			1.43 H	297	74.61	30.24
5	2483.50	60.76 PK	74.00	-13.24	1.42 H	300	30.33	30.43
6	2483.50	47.71 AV	54.00	-6.29	1.42 H	300	17.28	30.43
7	4874.00	46.10 PK	74.00	-27.90	1.10 H	313	10.55	35.55
8	4874.00	34.40 AV	54.00	-19.60	1.10 H	313	-1.15	35.55
9	7311.00	70.19 PK	74.00	-3.81	1.75 H	279	28.15	42.04
10	7311.00	42.43 AV	54.00	-11.57	1.75 H	279	0.39	42.04
ANTENNA POLARITY & TEST DISTANCE: VERTICAL AT 3 M								
NO.	FREQ. (MHz)	EMISSION LEVEL (dBuV/m)	LIMIT (dBuV/m)	MARGIN (dB)	ANTENNA HEIGHT (m)	TABLE ANGLE (Degree)	RAW VALUE (dBuV)	CORRECTION FACTOR (dB/m)
1	*2437.00	112.98 PK			1.24 V	175	82.74	30.24
2	*2437.00	103.42 AV			1.24 V	175	73.18	30.24
3	4874.00	56.20 PK	74.00	-17.80	1.44 V	24	20.65	35.55
4	4874.00	41.30 AV	54.00	-12.70	1.44 V	24	5.75	35.55
5	7311.00	72.14 PK	74.00	-1.86	1.24 V	312	30.10	42.04
6	7311.00	43.68 AV	54.00	-10.32	1.24 V	312	1.64	42.04

- REMARKS:**
1. Emission level (dBuV/m) = Raw Value (dBuV) + Correction Factor (dB/m).
  2. Correction Factor (dB/m) = Antenna Factor (dB/m) + Cable Factor (dB).
  3. The other emission levels were very low against the limit.
  4. Margin value = Emission level – Limit value.
  5. “ \* “: Fundamental frequency.



A D T

EUT TEST CONDITION		MEASUREMENT DETAIL	
CHANNEL	Channel 11	FREQUENCY RANGE	1 ~ 25GHz
INPUT POWER	120Vac, 60 Hz	DETECTOR FUNCTION	Peak (PK) Average (AV)
ENVIRONMENTAL CONDITIONS	30.0deg. C, 55.0%RH 965hPa	TESTED BY	Eric Lee

**ANTENNA POLARITY & TEST DISTANCE: HORIZONTAL AT 3 M**

NO.	FREQ. (MHz)	EMISSION LEVEL (dBuV/m)	LIMIT (dBuV/m)	MARGIN (dB)	ANTENNA HEIGHT (m)	TABLE ANGLE (Degree)	RAW VALUE (dBuV)	CORRECTION FACTOR (dB/m)
1	*2462.00	120.20 PK			1.41 H	297	89.86	30.34
2	*2462.00	107.10 AV			1.41 H	297	76.76	30.34
3	2483.50	69.42 PK	74.00	-4.58	1.13 H	299	38.99	30.43
4	2483.50	53.08 AV	54.00	-0.92	1.13 H	299	22.65	30.43
5	4924.00	51.30 PK	74.00	-22.70	1.00 H	313	15.67	35.63
6	4924.00	35.70 AV	54.00	-18.30	1.00 H	313	0.07	35.63
7	7386.00	73.22 PK	74.00	-0.78	1.67 H	276	30.99	42.23
8	7386.00	43.78 AV	54.00	-10.22	1.67 H	276	1.55	42.23

**ANTENNA POLARITY & TEST DISTANCE: VERTICAL AT 3 M**

NO.	FREQ. (MHz)	EMISSION LEVEL (dBuV/m)	LIMIT (dBuV/m)	MARGIN (dB)	ANTENNA HEIGHT (m)	TABLE ANGLE (Degree)	RAW VALUE (dBuV)	CORRECTION FACTOR (dB/m)
1	*2462.00	118.72 PK			1.21 V	169	88.38	30.34
2	*2462.00	106.20 AV			1.21 V	169	75.86	30.34
3	2483.50	67.00 PK	74.00	-7.00	1.20 V	20	36.57	30.43
4	2483.50	50.65 AV	54.00	-3.35	1.20 V	20	20.22	30.43
5	4924.00	56.54 PK	74.00	-17.46	1.48 V	15	20.91	35.63
6	4924.00	41.77 AV	54.00	-12.23	1.48 V	15	6.14	35.63
7	7386.00	72.11 PK	74.00	-1.89	1.28 V	311	29.88	42.23
8	7386.00	43.76 AV	54.00	-10.24	1.28 V	311	1.53	42.23

- REMARKS:**
1. Emission level (dBuV/m) = Raw Value (dBuV) + Correction Factor (dB/m).
  2. Correction Factor (dB/m) = Antenna Factor (dB/m) + Cable Factor (dB).
  3. The other emission levels were very low against the limit.
  4. Margin value = Emission level – Limit value.
  5. “ \* “: Fundamental frequency.





A D T

### RESTRICTED BANDEDGE (802.11g MODE, CH1, HORIZONTAL )

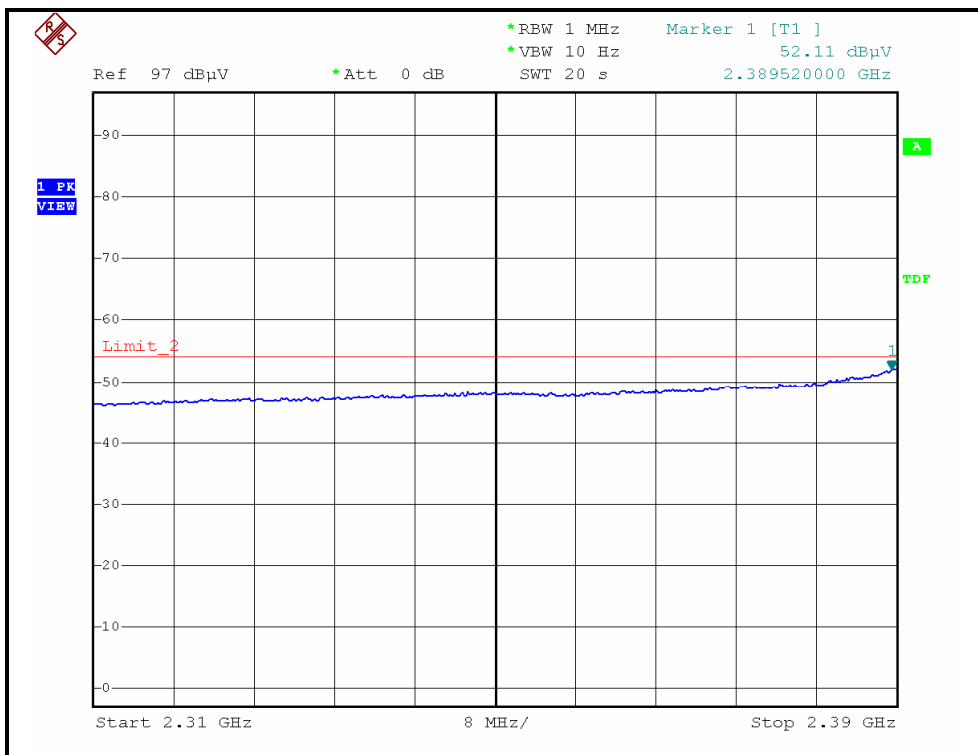
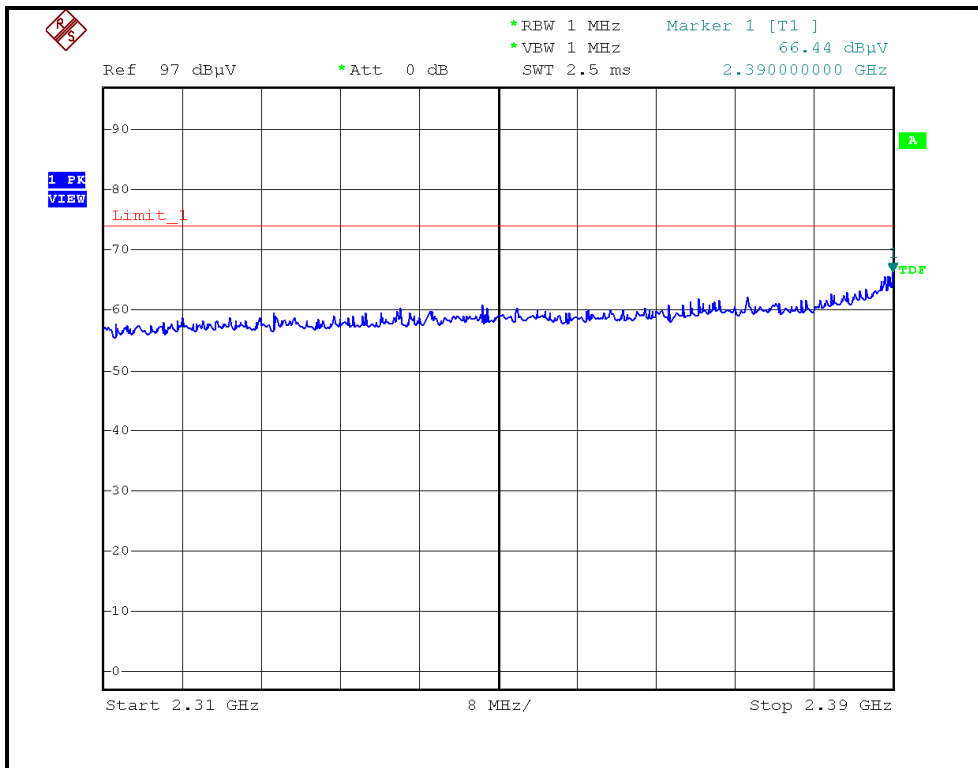



A D T

### RESTRICTED BANDEDGE (802.11g MODE,CH1, VERTICAL )

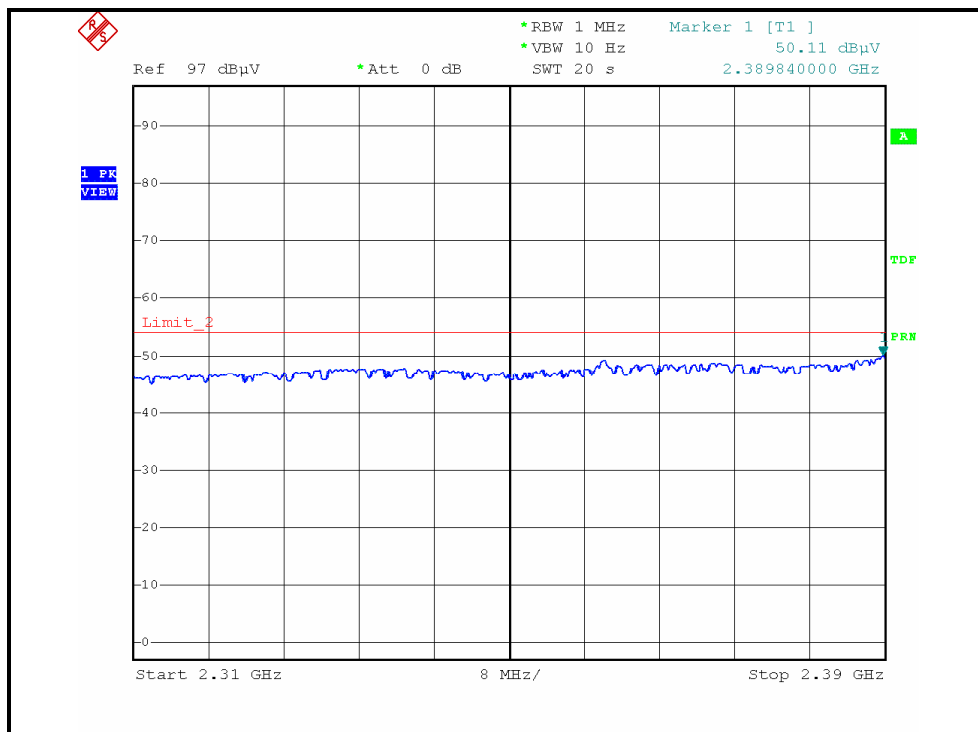
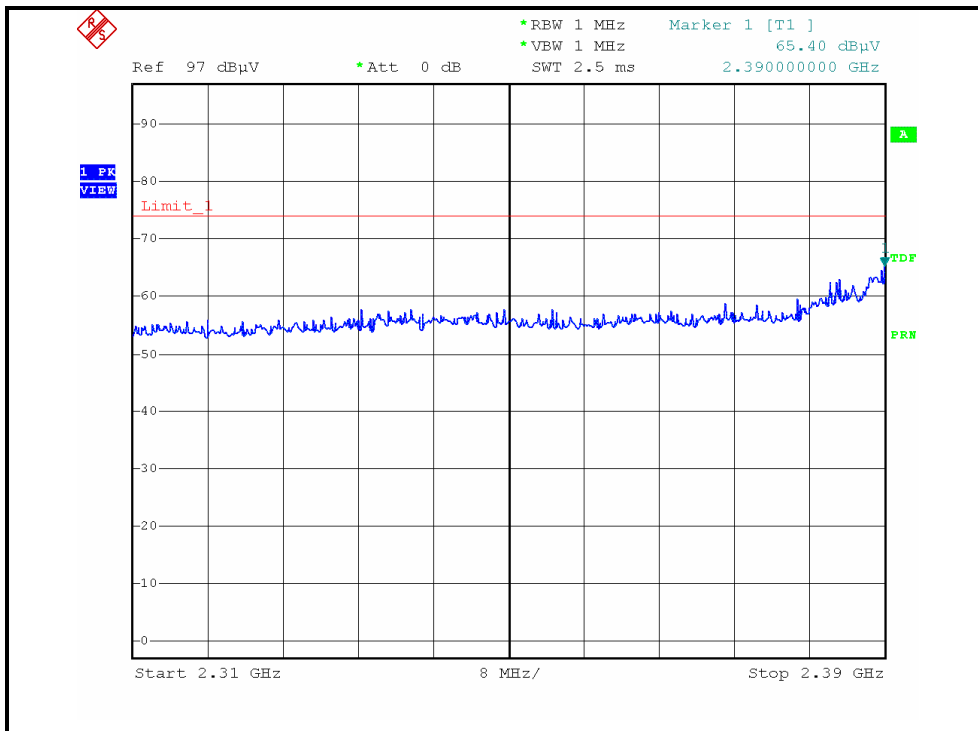



A D T

### RESTRICTED BANDEDGE (802.11g MODE,CH11, HORIZONTAL )

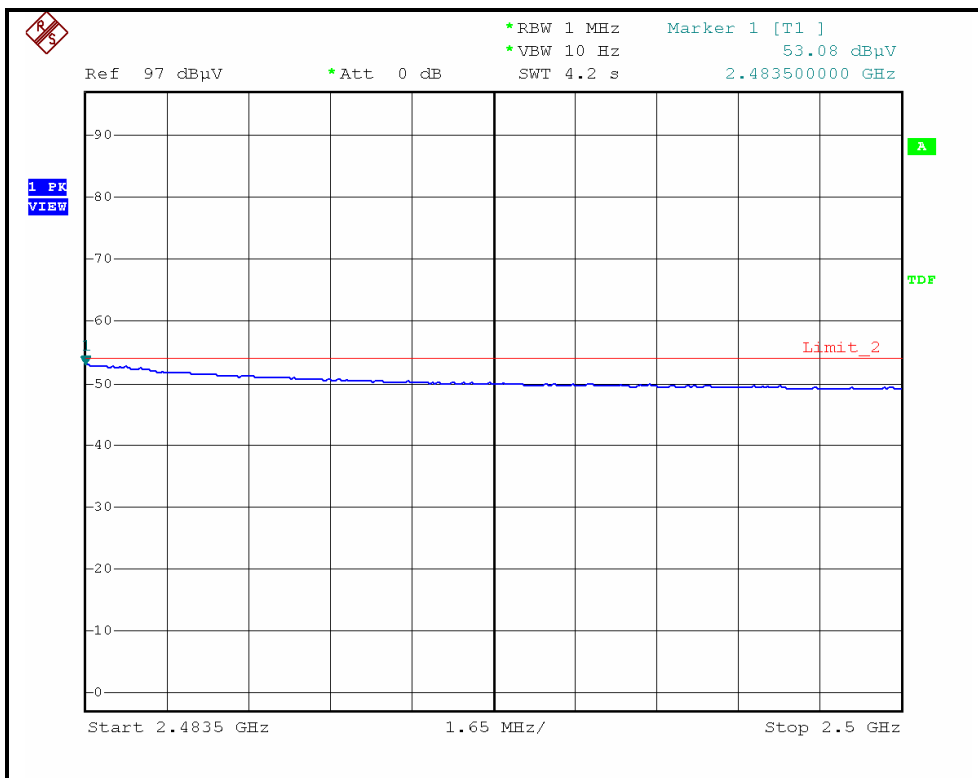
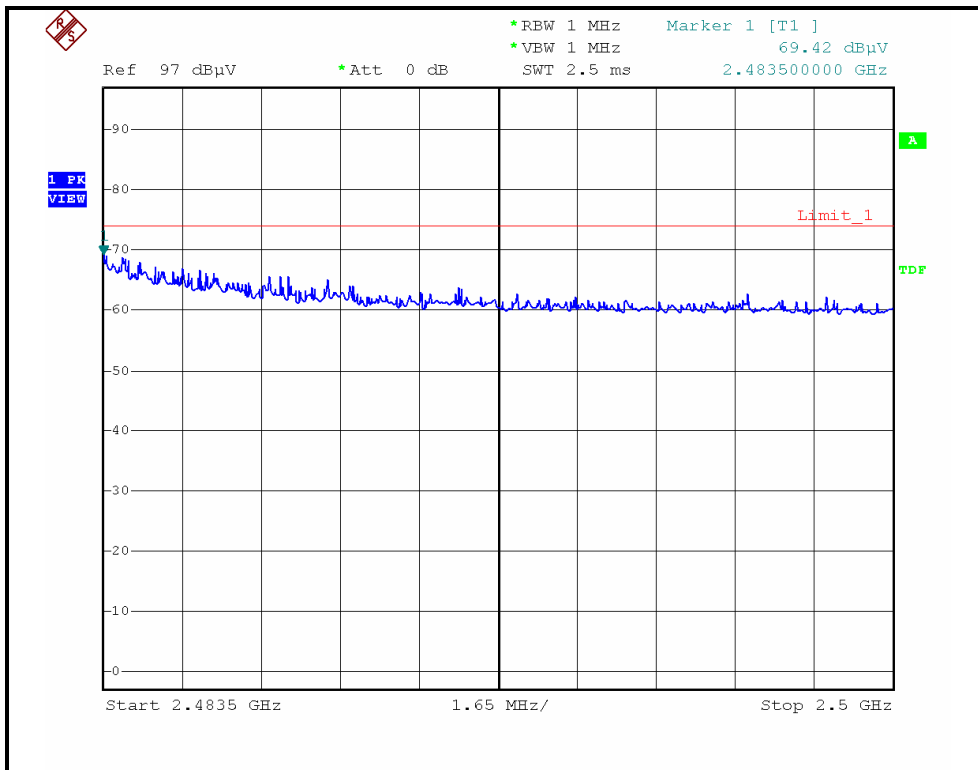



A D T

### RESTRICTED BANDEDGE (802.11g MODE,CH11, VERTICAL )

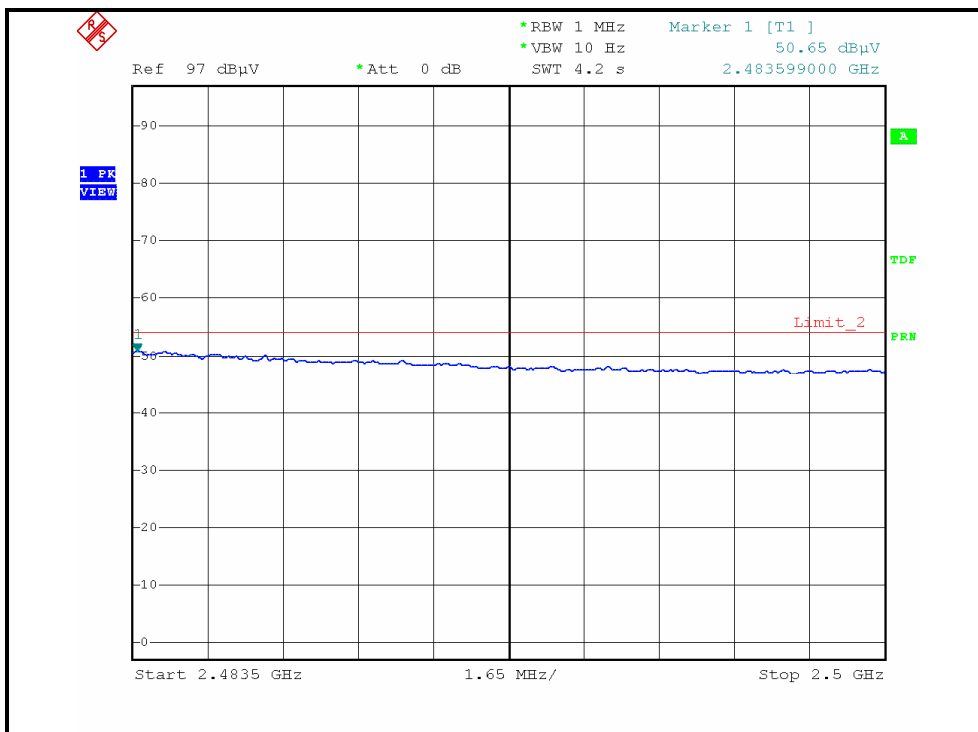
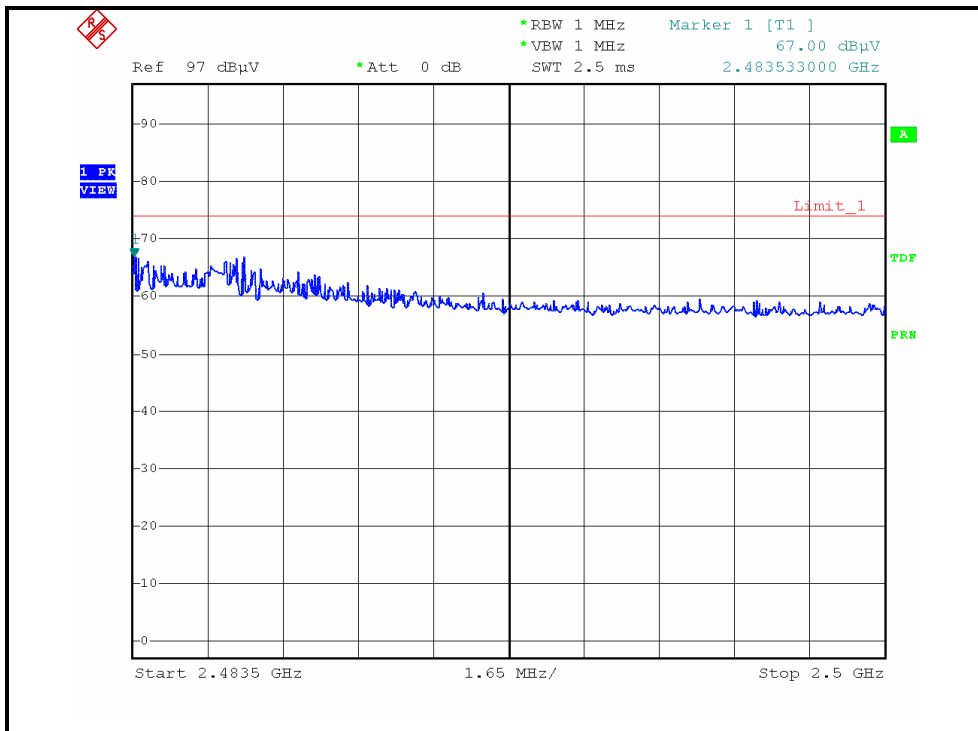



A D T

**DRAFT 802.11n (20MHz) OFDM MODULATION**

EUT TEST CONDITION		MEASUREMENT DETAIL	
CHANNEL	Channel 1	FREQUENCY RANGE	1 ~ 25GHz
INPUT POWER	120Vac, 60 Hz	DETECTOR FUNCTION	Peak (PK) Average (AV)
ENVIRONMENTAL CONDITIONS	30.0deg. C, 55.0%RH 965hPa	TESTED BY	Eric Lee

ANTENNA POLARITY & TEST DISTANCE: HORIZONTAL AT 3 M								
NO.	FREQ. (MHz)	EMISSION LEVEL (dBuV/m)	LIMIT (dBuV/m)	MARGIN (dB)	ANTENNA HEIGHT (m)	TABLE ANGLE (Degree)	RAW VALUE (dBuV)	CORRECTION FACTOR (dB/m)
1	2390.00	69.63 PK	74.00	-4.37	1.41 H	291	39.57	30.06
2	2390.00	52.81 AV	54.00	-1.19	1.41 H	291	22.75	30.06
3	*2412.00	116.40 PK			1.41 H	293	86.25	30.15
4	*2412.00	105.90 AV			1.41 H	293	75.75	30.15
5	4824.00	47.70 PK	74.00	-26.30	1.26 H	319	12.24	35.46
6	4824.00	33.90 AV	54.00	-20.10	1.26 H	319	-1.56	35.46
ANTENNA POLARITY & TEST DISTANCE: VERTICAL AT 3 M								
NO.	FREQ. (MHz)	EMISSION LEVEL (dBuV/m)	LIMIT (dBuV/m)	MARGIN (dB)	ANTENNA HEIGHT (m)	TABLE ANGLE (Degree)	RAW VALUE (dBuV)	CORRECTION FACTOR (dB/m)
1	2390.00	65.33 PK	74.00	-8.67	1.20 V	194	35.27	30.06
2	2390.00	50.45 AV	54.00	-3.55	1.20 V	194	20.39	30.06
3	*2412.00	114.30 PK			1.25 V	187	84.15	30.15
4	*2412.00	103.80 AV			1.25 V	187	73.65	30.15
5	4824.00	52.30 PK	74.00	-21.70	1.54 V	29	16.84	35.46
6	4824.00	38.60 AV	54.00	-15.40	1.54 V	29	3.14	35.46

- REMARKS:**
1. Emission level (dBuV/m) = Raw Value (dBuV) + Correction Factor (dB/m).
  2. Correction Factor (dB/m) = Antenna Factor (dB/m) + Cable Factor (dB).
  3. The other emission levels were very low against the limit.
  4. Margin value = Emission level – Limit value.
  5. “ \* “: Fundamental frequency.



A D T

EUT TEST CONDITION		MEASUREMENT DETAIL	
CHANNEL	Channel 6	FREQUENCY RANGE	1 ~ 25GHz
INPUT POWER	120Vac, 60 Hz	DETECTOR FUNCTION	Peak (PK) Average (AV)
ENVIRONMENTAL CONDITIONS	30.0deg. C, 55.0%RH 965hPa	TESTED BY	Eric Lee

ANTENNA POLARITY & TEST DISTANCE: HORIZONTAL AT 3 M								
NO.	FREQ. (MHz)	EMISSION LEVEL (dBuV/m)	LIMIT (dBuV/m)	MARGIN (dB)	ANTENNA HEIGHT (m)	TABLE ANGLE (Degree)	RAW VALUE (dBuV)	CORRECTION FACTOR (dB/m)
1	2390.00	60.87 PK	74.00	-13.13	1.42 H	293	30.81	30.06
2	2390.00	48.69 AV	54.00	-5.31	1.42 H	293	18.63	30.06
3	*2437.00	115.92 PK			1.43 H	298	85.68	30.24
4	*2437.00	105.23 AV			1.43 H	298	74.99	30.24
5	2483.50	60.73 PK	74.00	-13.27	1.43 H	298	30.30	30.43
6	2483.50	48.31 AV	54.00	-5.69	1.43 H	298	17.88	30.43
7	4874.00	50.10 PK	74.00	-23.90	1.14 H	318	14.55	35.55
8	4874.00	34.30 AV	54.00	-19.70	1.14 H	318	-1.25	35.55
9	7311.00	69.29 PK	74.00	-4.71	1.75 H	280	27.25	42.04
10	7311.00	42.43 AV	54.00	-11.57	1.75 H	280	0.39	42.04
ANTENNA POLARITY & TEST DISTANCE: VERTICAL AT 3 M								
NO.	FREQ. (MHz)	EMISSION LEVEL (dBuV/m)	LIMIT (dBuV/m)	MARGIN (dB)	ANTENNA HEIGHT (m)	TABLE ANGLE (Degree)	RAW VALUE (dBuV)	CORRECTION FACTOR (dB/m)
1	*2437.00	114.70 PK			1.24 V	173	84.46	30.24
2	*2437.00	104.10 AV			1.24 V	173	73.86	30.24
3	4874.00	54.30 PK	74.00	-19.70	1.56 V	32	18.75	35.55
4	4874.00	39.20 AV	54.00	-14.80	1.56 V	32	3.65	35.55
5	7311.00	69.34 PK	74.00	-4.66	2.09 V	52	27.30	42.04
6	7311.00	42.10 AV	54.00	-11.90	2.09 V	52	0.06	42.04

- REMARKS:**
1. Emission level (dBuV/m) = Raw Value (dBuV) + Correction Factor (dB/m).
  2. Correction Factor (dB/m) = Antenna Factor (dB/m) + Cable Factor (dB).
  3. The other emission levels were very low against the limit.
  4. Margin value = Emission level – Limit value.
  5. “ \* “: Fundamental frequency.



A D T

EUT TEST CONDITION		MEASUREMENT DETAIL	
CHANNEL	Channel 11	FREQUENCY RANGE	1 ~ 25GHz
INPUT POWER	120Vac, 60 Hz	DETECTOR FUNCTION	Peak (PK) Average (AV)
ENVIRONMENTAL CONDITIONS	30.0deg. C, 55.0%RH 965hPa	TESTED BY	Eric Lee

ANTENNA POLARITY & TEST DISTANCE: HORIZONTAL AT 3 M								
NO.	FREQ. (MHz)	EMISSION LEVEL (dBuV/m)	LIMIT (dBuV/m)	MARGIN (dB)	ANTENNA HEIGHT (m)	TABLE ANGLE (Degree)	RAW VALUE (dBuV)	CORRECTION FACTOR (dB/m)
1	*2462.00	119.30 PK			1.42 H	299	88.96	30.34
2	*2462.00	106.80 AV			1.42 H	299	76.46	30.34
3	2483.50	69.51 PK	74.00	-4.49	1.42 H	198	39.08	30.43
4	2483.50	53.33 AV	54.00	-0.67	1.42 H	198	22.90	30.43
5	4924.00	49.50 PK	74.00	-24.50	1.00 H	256	13.87	35.63
6	4924.00	34.60 AV	54.00	-19.40	1.00 H	256	-1.03	35.63
7	7386.00	73.23 PK	74.00	-0.77	1.67 H	281	31.00	42.23
8	7386.00	42.94 AV	54.00	-11.06	1.67 H	281	0.71	42.23
ANTENNA POLARITY & TEST DISTANCE: VERTICAL AT 3 M								
NO.	FREQ. (MHz)	EMISSION LEVEL (dBuV/m)	LIMIT (dBuV/m)	MARGIN (dB)	ANTENNA HEIGHT (m)	TABLE ANGLE (Degree)	RAW VALUE (dBuV)	CORRECTION FACTOR (dB/m)
1	*2462.00	108.10 PK			1.36 V	134	77.76	30.34
2	*2462.00	105.20 AV			1.36 V	134	74.86	30.34
3	2483.79	67.00 PK	74.00	-7.00	1.24 V	198	36.57	30.43
4	2483.79	50.77 AV	54.00	-3.23	1.24 V	198	20.34	30.43
5	4924.00	53.60 PK	74.00	-20.40	1.24 V	51	17.97	35.63
6	4924.00	38.70 AV	54.00	-15.30	1.24 V	51	3.07	35.63
7	7386.00	71.34 PK	74.00	-2.66	2.01 V	53	29.11	42.23
8	7386.00	41.84 AV	54.00	-12.16	2.01 V	53	-0.39	42.23

- REMARKS:**
1. Emission level (dBuV/m) = Raw Value (dBuV) + Correction Factor (dB/m).
  2. Correction Factor (dB/m) = Antenna Factor (dB/m) + Cable Factor (dB).
  3. The other emission levels were very low against the limit.
  4. Margin value = Emission level – Limit value.
  5. “ \* “: Fundamental frequency.



A D T

### RESTRICTED BANDEDGE (DRAFT 802.11n (20MHz) MODE, CH1, HORIZONTAL )

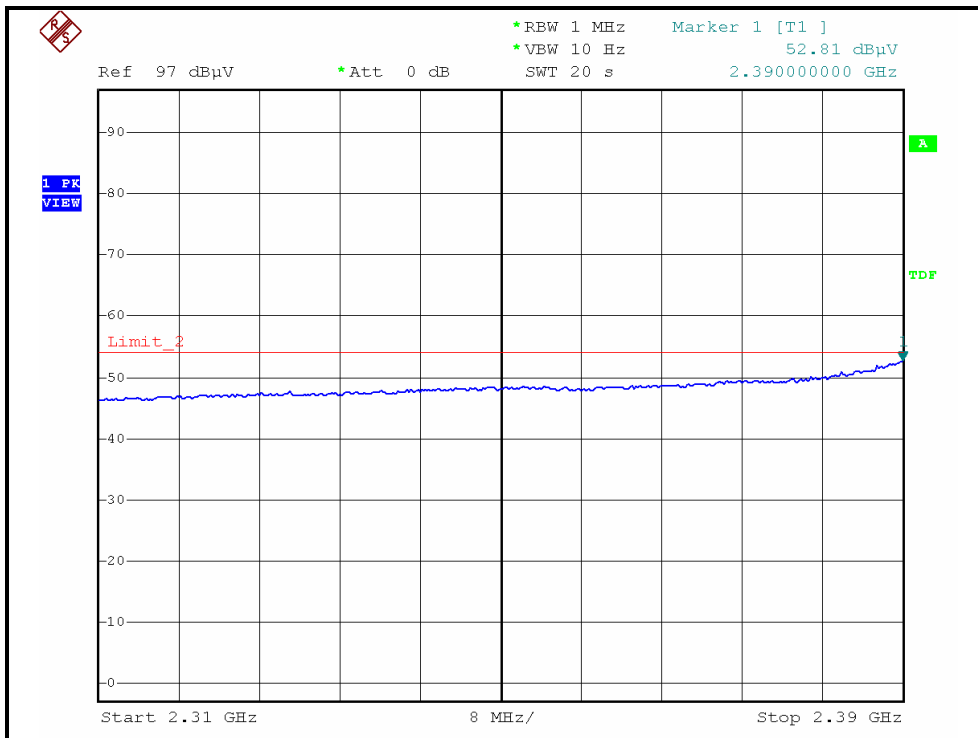
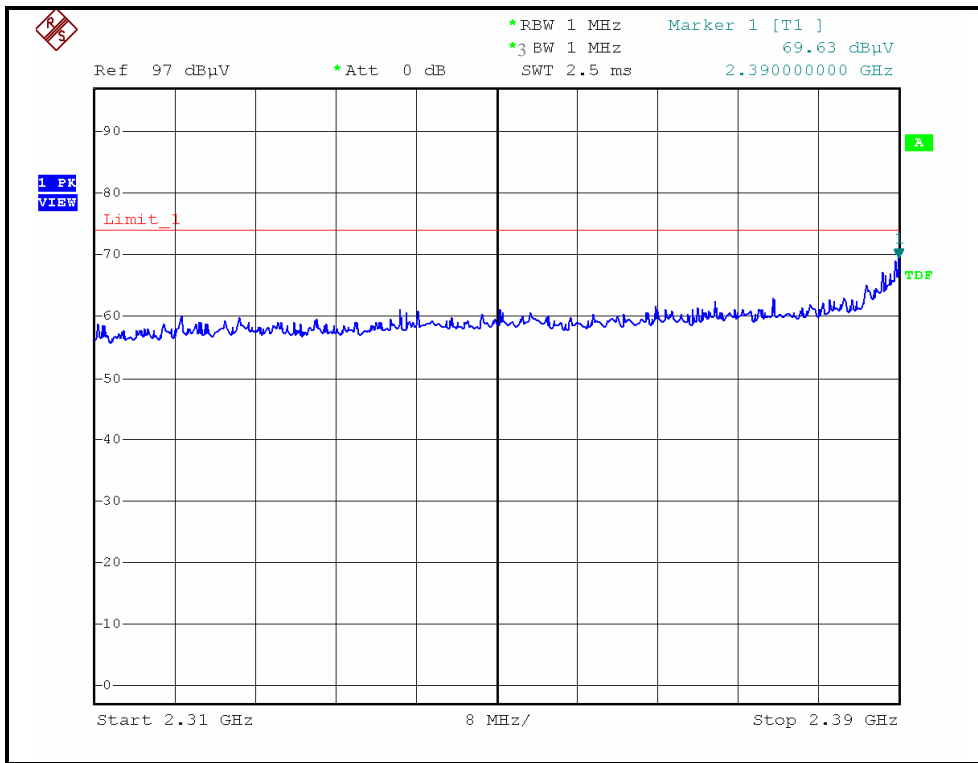





A D T

### RESTRICTED BANDEDGE (DRAFT 802.11n (20MHz) MODE,CH1, VERTICAL )

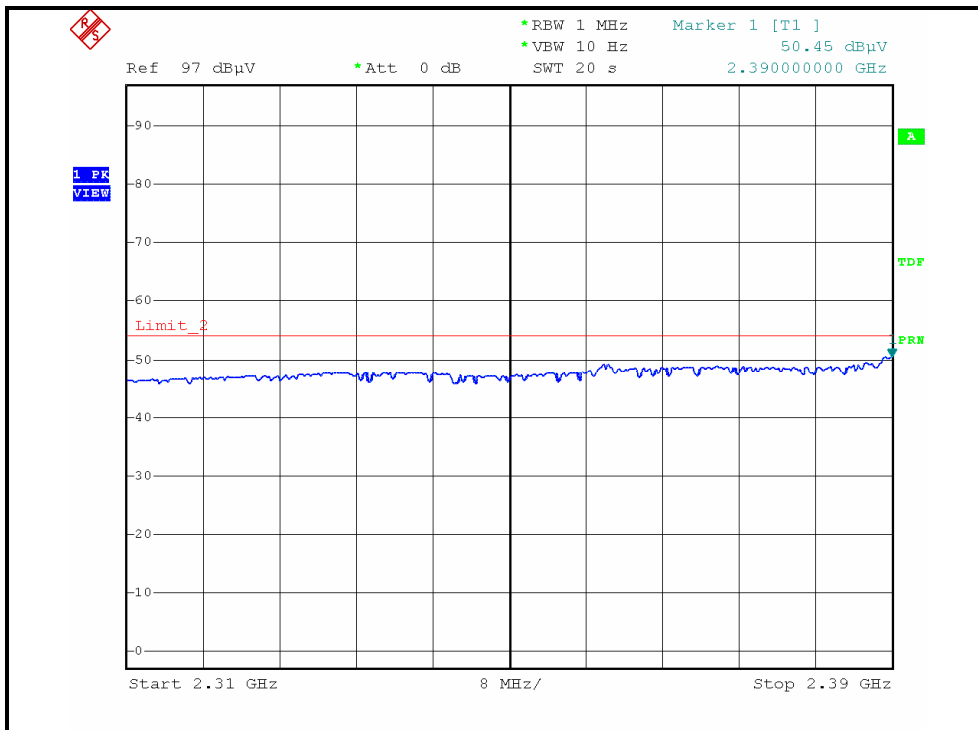
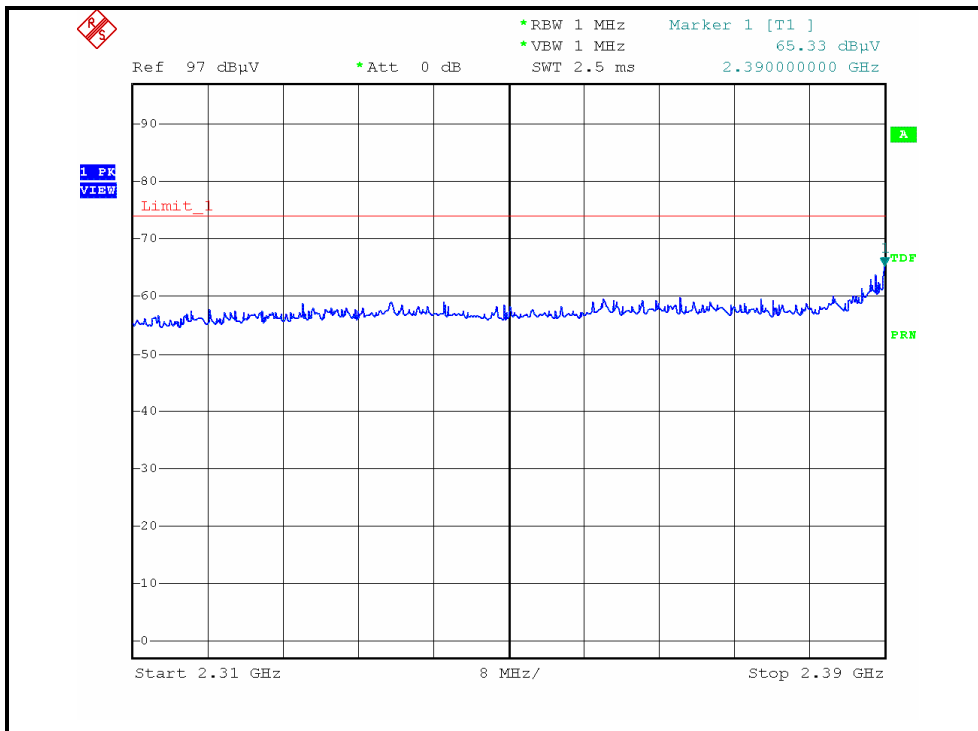



A D T

### RESTRICTED BANDEDGE (DRAFT 802.11n (20MHz) MODE, CH11, HORIZONTAL )

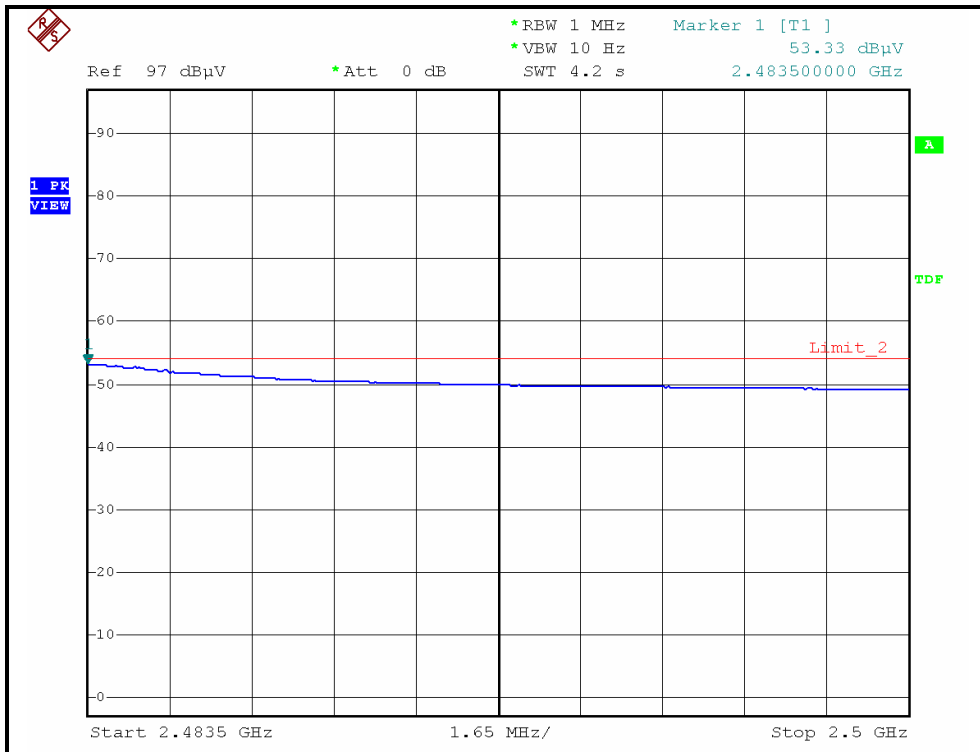
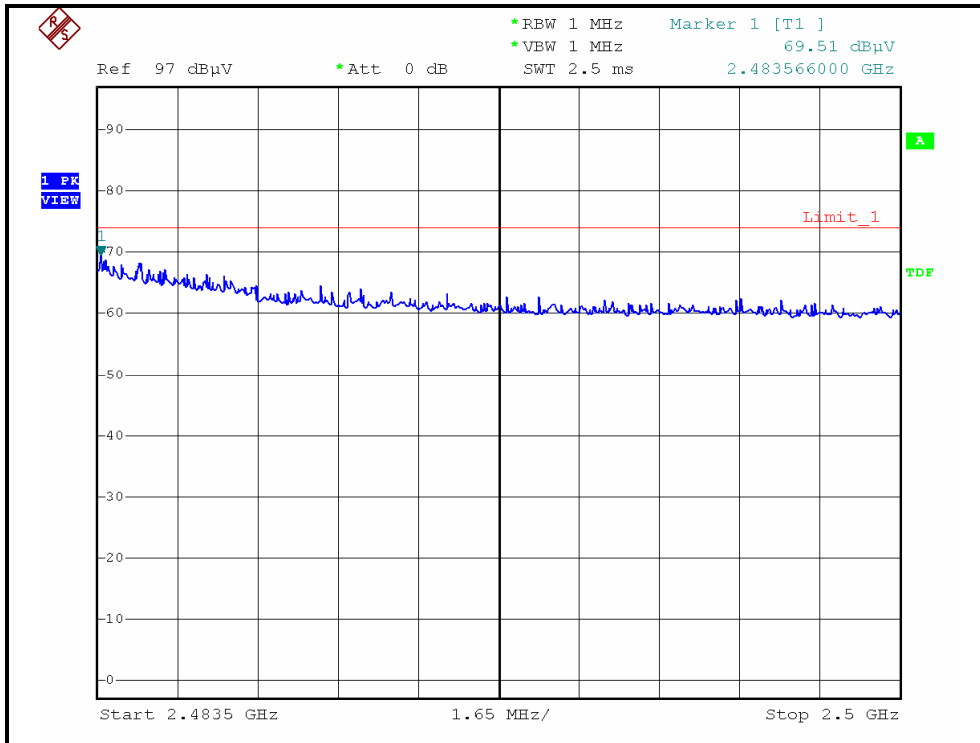



A D T

### RESTRICTED BANDEDGE (DRAFT 802.11n (20MHz) MODE,CH11, VERTICAL )

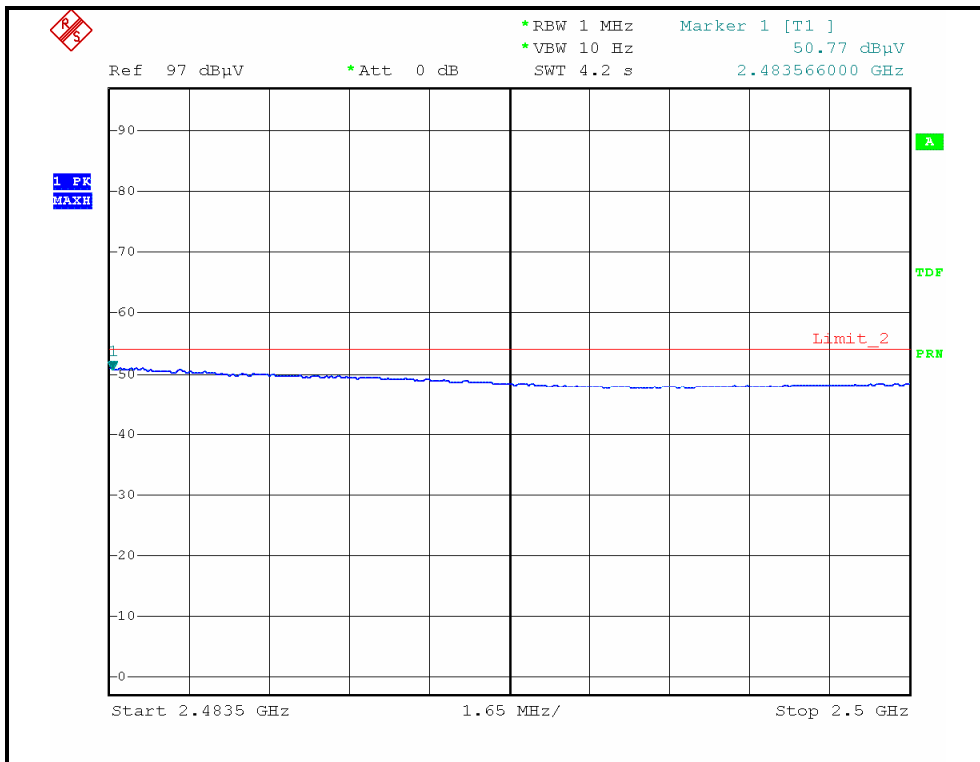
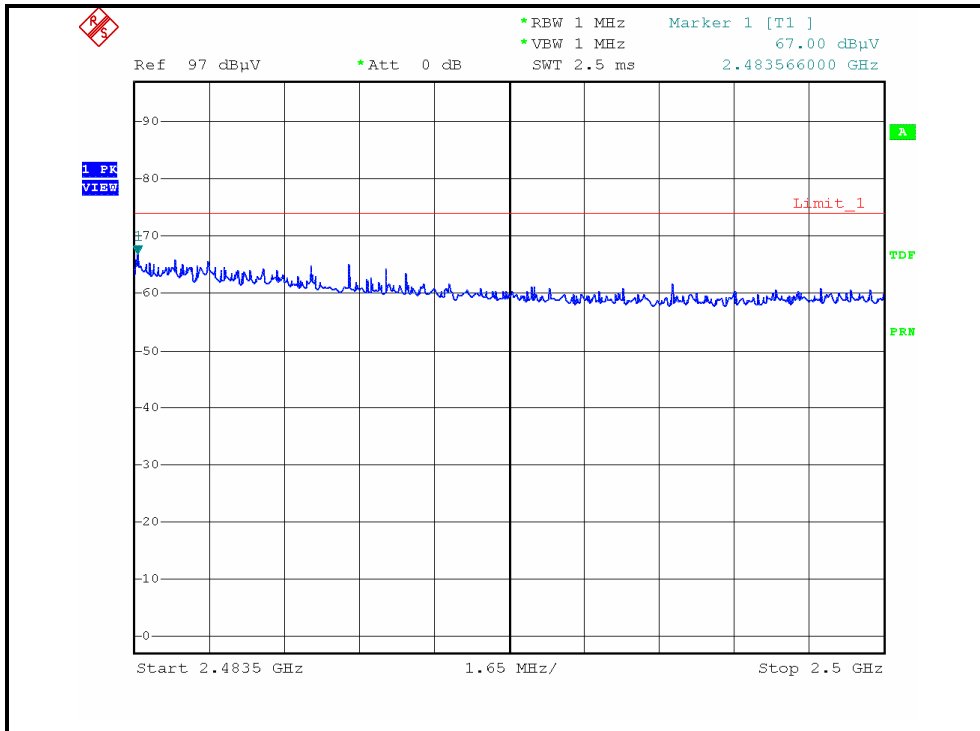



A D T

**DRAFT 802.11n (40MHz) OFDM MODULATION**

EUT TEST CONDITION		MEASUREMENT DETAIL	
CHANNEL	Channel 1	FREQUENCY RANGE	1 ~ 25GHz
INPUT POWER	120Vac, 60 Hz	DETECTOR FUNCTION	Peak (PK) Average (AV)
ENVIRONMENTAL CONDITIONS	30.0deg. C, 55.0%RH 965hPa	TESTED BY	Eric Lee

ANTENNA POLARITY & TEST DISTANCE: HORIZONTAL AT 3 M								
NO.	FREQ. (MHz)	EMISSION LEVEL (dBuV/m)	LIMIT (dBuV/m)	MARGIN (dB)	ANTENNA HEIGHT (m)	TABLE ANGLE (Degree)	RAW VALUE (dBuV)	CORRECTION FACTOR (dB/m)
1	2390.00	72.16 PK	74.00	-1.84	1.41 H	292	42.10	30.06
2	2390.00	53.16 AV	54.00	-0.84	1.41 H	292	23.10	30.06
3	*2422.00	112.60 PK			1.41 H	293	82.41	30.19
4	*2422.00	99.40 AV			1.41 H	293	69.21	30.19
5	4844.00	47.90 PK	74.00	-26.10	1.04 H	301	12.40	35.50
6	4844.00	33.20 AV	54.00	-20.80	1.04 H	301	-2.30	35.50
7	7266.00	65.20 PK	74.00	-8.80	1.43 H	284	23.27	41.93
8	7266.00	51.30 AV	54.00	-2.70	1.43 H	284	9.37	41.93
ANTENNA POLARITY & TEST DISTANCE: VERTICAL AT 3 M								
NO.	FREQ. (MHz)	EMISSION LEVEL (dBuV/m)	LIMIT (dBuV/m)	MARGIN (dB)	ANTENNA HEIGHT (m)	TABLE ANGLE (Degree)	RAW VALUE (dBuV)	CORRECTION FACTOR (dB/m)
1	2390.00	67.70 PK	74.00	-6.30	1.24 V	182	37.64	30.06
2	2390.00	50.60 AV	54.00	-3.40	1.24 V	182	20.54	30.06
3	*2422.00	111.62 PK			1.21 V	179	81.43	30.19
4	*2422.00	98.04 AV			1.21 V	179	67.85	30.19
5	4844.00	50.20 PK	74.00	-23.80	1.54 V	37	14.70	35.50
6	4844.00	36.40 AV	54.00	-17.60	1.54 V	37	0.90	35.50
7	7266.00	67.40 PK	74.00	-6.60	1.26 V	159	25.47	41.93
8	7266.00	51.30 AV	54.00	-2.70	1.26 V	159	9.37	41.93

- REMARKS:**
1. Emission level (dBuV/m) = Raw Value (dBuV) + Correction Factor (dB/m).
  2. Correction Factor (dB/m) = Antenna Factor (dB/m) + Cable Factor (dB).
  3. The other emission levels were very low against the limit.
  4. Margin value = Emission level – Limit value.
  5. “ \* “: Fundamental frequency.



A D T

EUT TEST CONDITION		MEASUREMENT DETAIL	
CHANNEL	Channel 4	FREQUENCY RANGE	1 ~ 25GHz
INPUT POWER	120Vac, 60 Hz	DETECTOR FUNCTION	Peak (PK) Average (AV)
ENVIRONMENTAL CONDITIONS	30.0deg. C, 55.0%RH 965hPa	TESTED BY	Eric Lee

**ANTENNA POLARITY & TEST DISTANCE: HORIZONTAL AT 3 M**

NO.	FREQ. (MHz)	EMISSION LEVEL (dBuV/m)	LIMIT (dBuV/m)	MARGIN (dB)	ANTENNA HEIGHT (m)	TABLE ANGLE (Degree)	RAW VALUE (dBuV)	CORRECTION FACTOR (dB/m)
1	2390.00	63.00 PK	74.00	-11.00	1.41 H	292	32.94	30.06
2	2390.00	53.30 AV	54.00	-0.70	1.41 H	292	23.24	30.06
3	*2437.00	115.20 PK			1.41 H	294	84.96	30.24
4	*2437.00	101.70 AV			1.41 H	294	71.46	30.24
5	2483.50	66.30 PK	74.00	-7.70	1.41 H	297	35.87	30.43
6	2483.50	51.70 AV	54.00	-2.30	1.41 H	297	21.27	30.43
7	4874.00	48.70 PK	74.00	-25.30	1.12 H	309	13.15	35.55
8	4874.00	38.70 AV	54.00	-15.30	1.12 H	309	3.15	35.55
9	7311.00	72.98 PK	74.00	-1.02	1.76 H	276	30.94	42.04
10	7311.00	41.40 AV	54.00	-12.60	1.76 H	276	-0.64	42.04

**ANTENNA POLARITY & TEST DISTANCE: VERTICAL AT 3 M**

NO.	FREQ. (MHz)	EMISSION LEVEL (dBuV/m)	LIMIT (dBuV/m)	MARGIN (dB)	ANTENNA HEIGHT (m)	TABLE ANGLE (Degree)	RAW VALUE (dBuV)	CORRECTION FACTOR (dB/m)
1	2390.00	67.60 PK	74.00	-6.40	1.48 V	163	37.54	30.06
2	2390.00	52.50 AV	54.00	-1.50	1.48 V	163	22.44	30.06
3	*2437.00	114.10 PK			1.00 V	184	83.86	30.24
4	*2437.00	99.23 AV			1.00 V	184	68.99	30.24
5	4874.00	50.80 PK	74.00	-23.20	1.64 V	29	15.25	35.55
6	4874.00	35.90 AV	54.00	-18.10	1.64 V	29	0.35	35.55
7	7311.00	70.30 PK	74.00	-3.70	1.84 V	69	28.26	42.04
8	7311.00	40.20 AV	54.00	-13.80	1.84 V	69	-1.84	42.04

- REMARKS:**
1. Emission level (dBuV/m) = Raw Value (dBuV) + Correction Factor (dB/m).
  2. Correction Factor (dB/m) = Antenna Factor (dB/m) + Cable Factor (dB).
  3. The other emission levels were very low against the limit.
  4. Margin value = Emission level – Limit value.
  5. “ \* “: Fundamental frequency.



A D T

EUT TEST CONDITION		MEASUREMENT DETAIL	
CHANNEL	Channel 7	FREQUENCY RANGE	1 ~ 25GHz
INPUT POWER	120Vac, 60 Hz	DETECTOR FUNCTION	Peak (PK) Average (AV)
ENVIRONMENTAL CONDITIONS	30.0deg. C, 55.0%RH 965hPa	TESTED BY	Eric Lee

**ANTENNA POLARITY & TEST DISTANCE: HORIZONTAL AT 3 M**

NO.	FREQ. (MHz)	EMISSION LEVEL (dBuV/m)	LIMIT (dBuV/m)	MARGIN (dB)	ANTENNA HEIGHT (m)	TABLE ANGLE (Degree)	RAW VALUE (dBuV)	CORRECTION FACTOR (dB/m)
1	*2452.00	112.19 PK			1.41 H	297	81.89	30.30
2	*2452.00	102.07 AV			1.41 H	297	71.77	30.30
3	2483.50	72.40 PK	74.00	-1.60	1.41 H	298	41.97	30.43
4	2483.50	53.04 AV	54.00	-0.96	1.41 H	298	22.61	30.43
5	4904.00	47.60 PK	74.00	-26.40	1.17 H	326	12.00	35.60
6	4904.00	33.90 AV	54.00	-20.10	1.17 H	326	-1.70	35.60
7	7356.00	70.96 PK	74.00	-3.04	1.76 H	284	28.80	42.16
8	7356.00	40.61 AV	54.00	-13.39	1.76 H	284	-1.55	42.16

**ANTENNA POLARITY & TEST DISTANCE: VERTICAL AT 3 M**

NO.	FREQ. (MHz)	EMISSION LEVEL (dBuV/m)	LIMIT (dBuV/m)	MARGIN (dB)	ANTENNA HEIGHT (m)	TABLE ANGLE (Degree)	RAW VALUE (dBuV)	CORRECTION FACTOR (dB/m)
1	*2452.00	111.24 PK			1.24 V	172	80.94	30.30
2	*2452.00	101.63 AV			1.24 V	172	71.33	30.30
3	2483.50	67.20 PK	74.00	-6.80	1.24 V	51	36.77	30.43
4	2483.50	52.00 AV	54.00	-2.00	1.24 V	51	21.57	30.43
5	4904.00	51.40 PK	74.00	-22.60	1.74 V	72	15.80	35.60
6	4904.00	36.60 AV	54.00	-17.40	1.74 V	72	1.00	35.60
7	7356.00	69.30 PK	74.00	-4.70	1.81 V	72	27.14	42.16
8	7356.00	40.90 AV	54.00	-13.10	1.81 V	72	-1.26	42.16

- REMARKS:**
1. Emission level (dBuV/m) = Raw Value (dBuV) + Correction Factor (dB/m).
  2. Correction Factor (dB/m) = Antenna Factor (dB/m) + Cable Factor (dB).
  3. The other emission levels were very low against the limit.
  4. Margin value = Emission level – Limit value.
  5. “ \* “: Fundamental frequency.



A D T

### RESTRICTED BANDEDGE (DRAFT 802.11n (40MHz) MODE,CH1, HORIZONTAL )

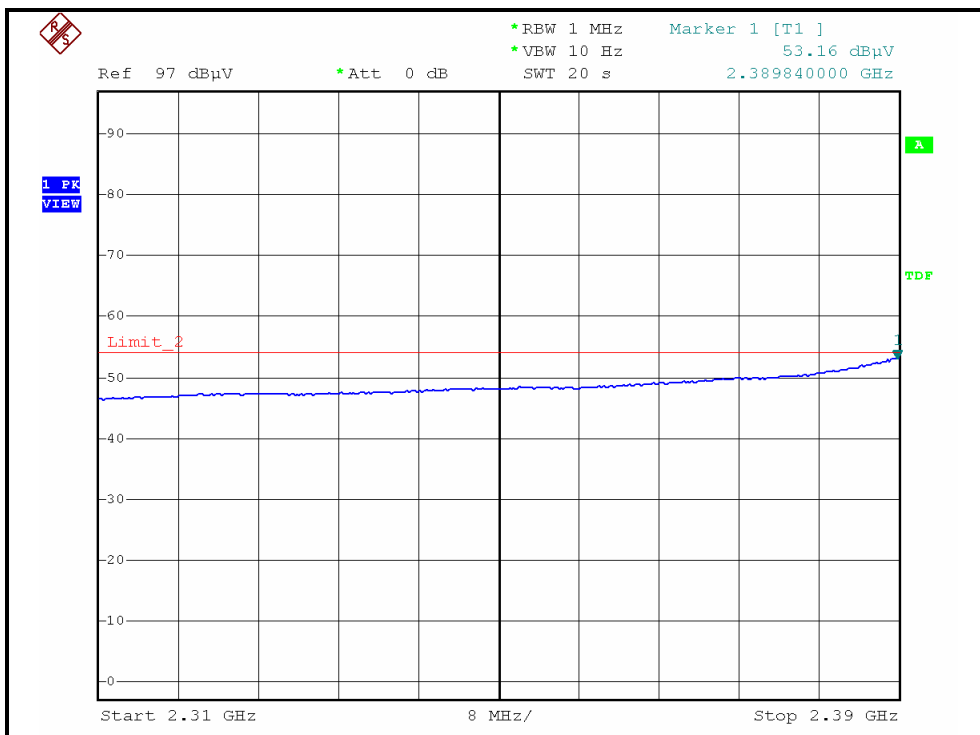
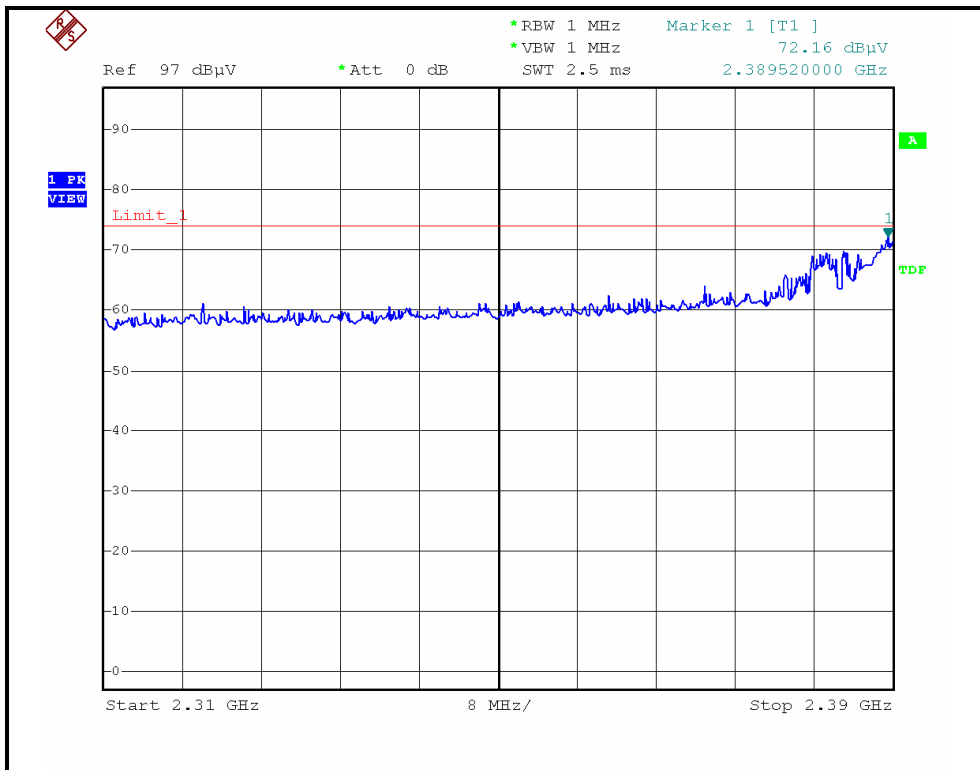



A D T

### RESTRICTED BANDEDGE (DRAFT 802.11n (40MHz) MODE,CH1, VERTICAL )

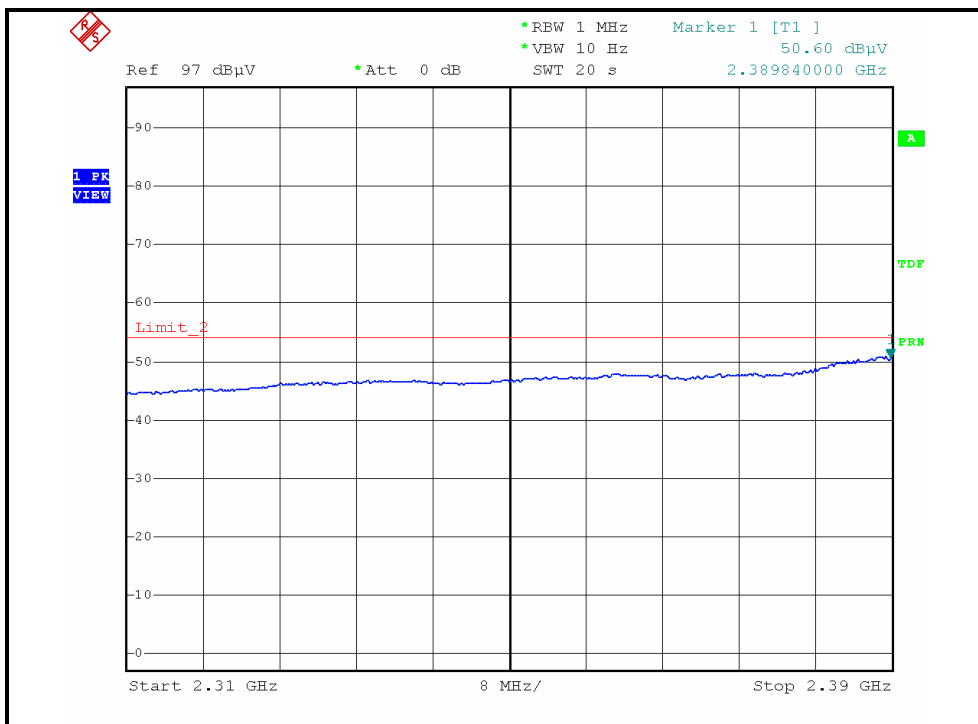
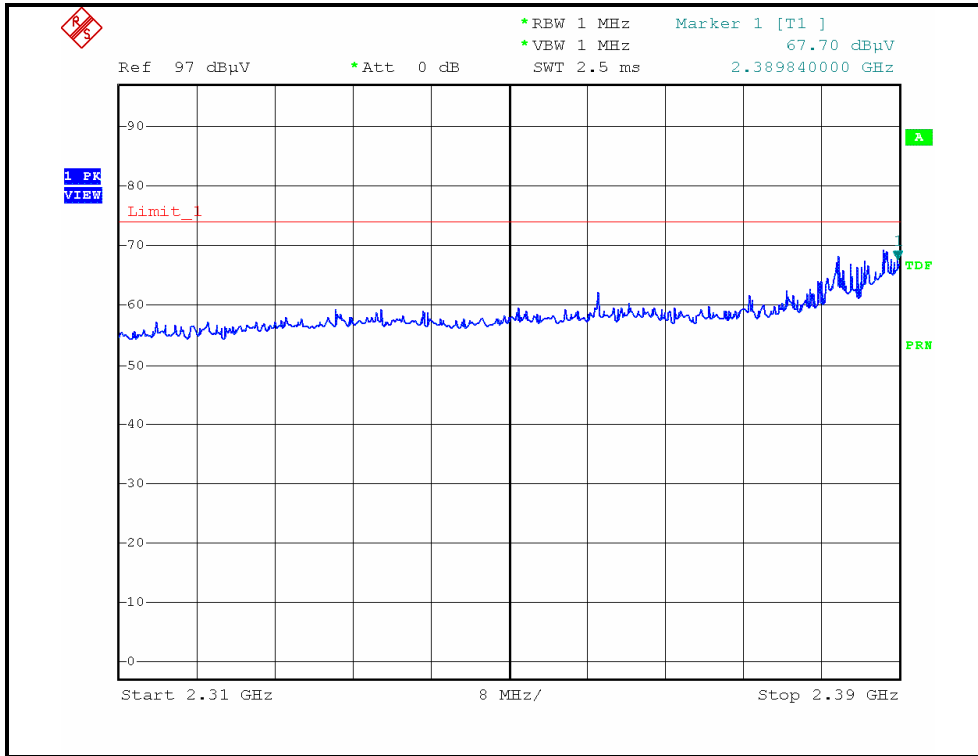





A D T

### RESTRICTED BANDEDGE (DRAFT 802.11n (40MHz) MODE,CH7, HORIZONTAL )

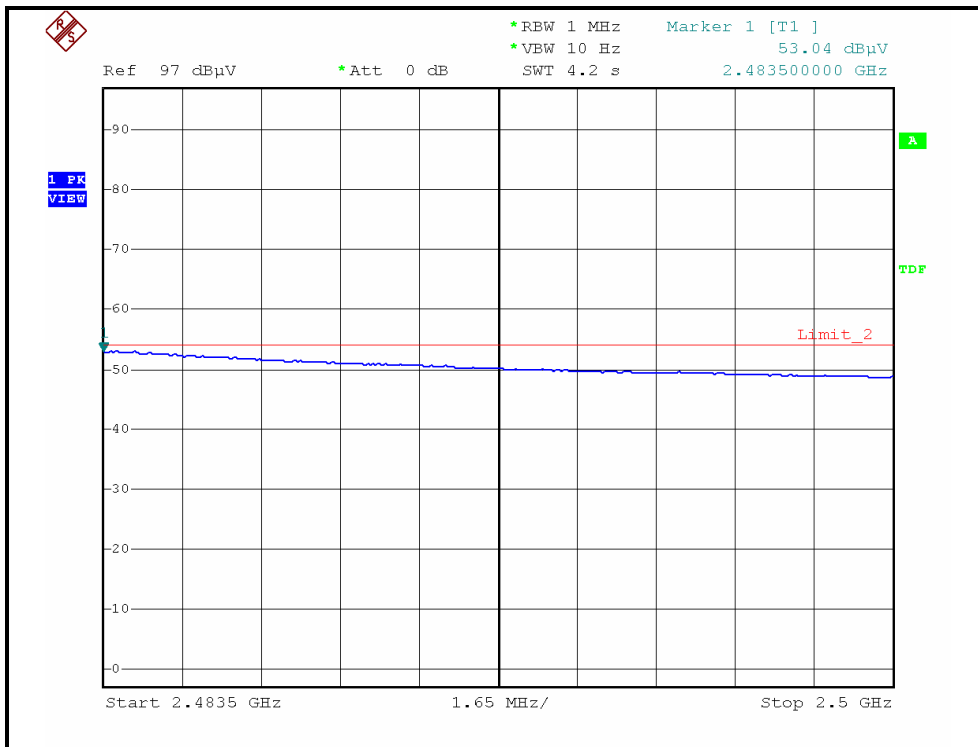
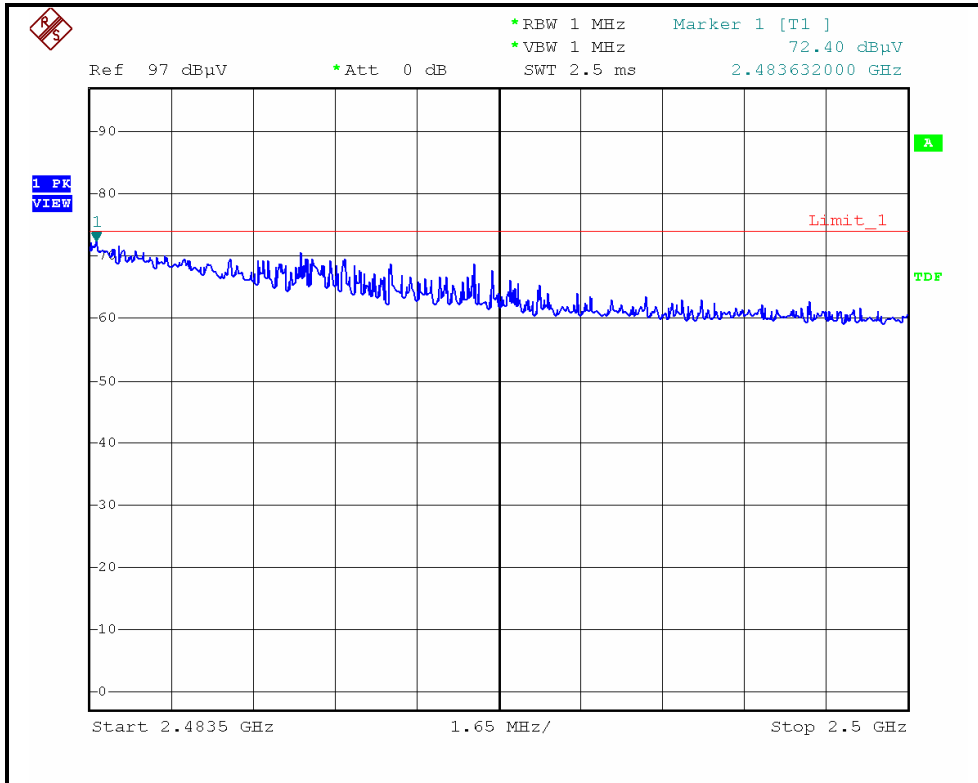



A D T

### RESTRICTED BANDEDGE (DRAFT 802.11n (40MHz) MODE,CH7, VERTICAL )

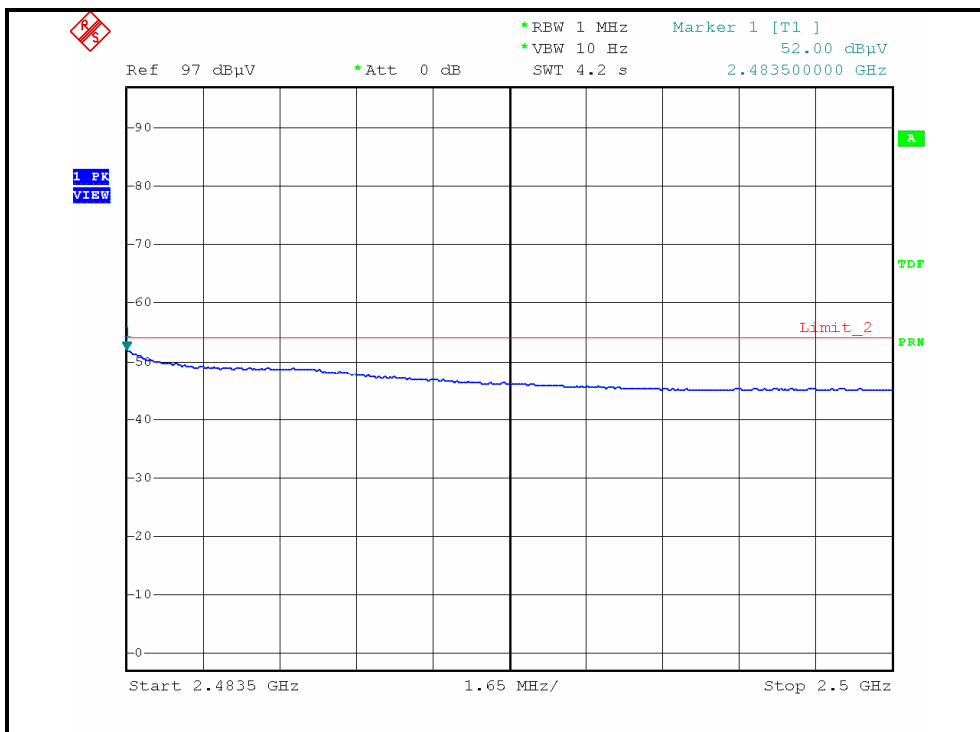
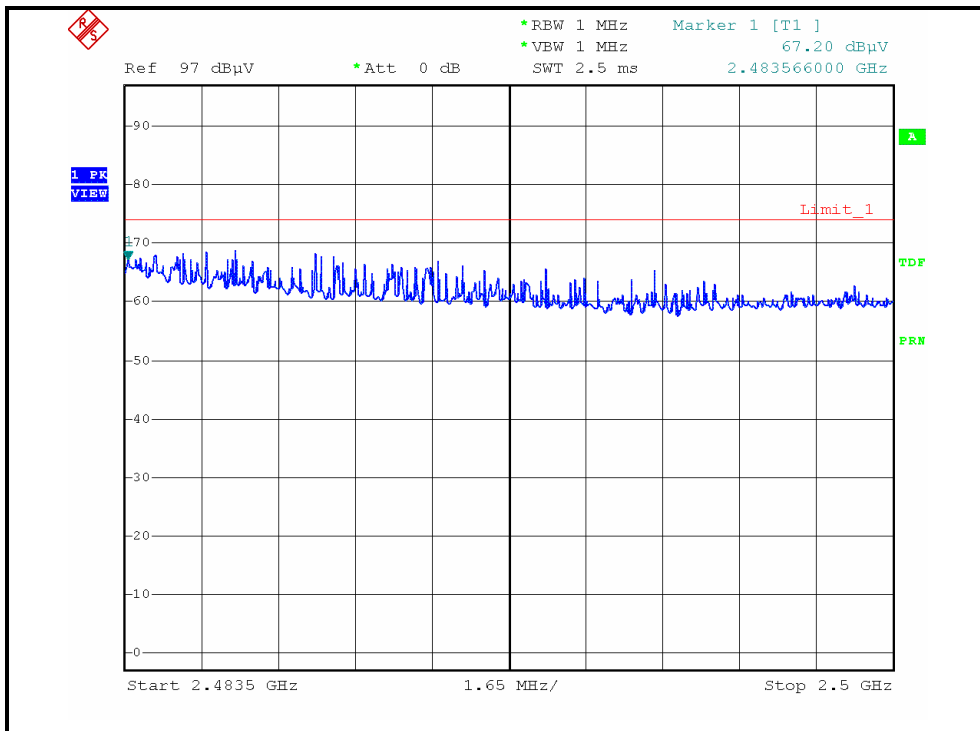



A D T

#### 4.2.10 TEST RESULTS –ANTENNA 6

#### BELOW 1GHz WORST-CASE DATA : 802.11b DSSS MODULATION

EUT TEST CONDITION		MEASUREMENT DETAIL	
CHANNEL	Channel 1	FREQUENCY RANGE	Below 1000MHz
INPUT POWER	120Vac, 60 Hz	DETECTOR FUNCTION	Quasi-Peak
ENVIRONMENTAL CONDITIONS	25.0deg. C, 72.0%RH 965hPa	TESTED BY	Frank Liu

ANTENNA POLARITY & TEST DISTANCE: HORIZONTAL AT 3 M								
NO.	FREQ. (MHz)	EMISSION LEVEL (dBuV/m)	LIMIT (dBuV/m)	MARGIN (dB)	ANTENNA HEIGHT (m)	TABLE ANGLE (Degree)	RAW VALUE (dBuV)	CORRECTION FACTOR (dB/m)
1	125.00	30.68 QP	43.50	-12.82	2.11 H	169	17.61	13.07
2	250.00	43.56 QP	46.00	-2.44	1.03 H	243	29.31	14.25
3	274.00	39.12 QP	46.00	-6.88	1.06 H	64	23.62	15.50
4	375.00	39.12 QP	46.00	-6.88	1.09 H	172	20.31	18.81
5	649.99	43.46 QP	46.00	-2.54	1.05 H	153	17.93	25.53
6	749.99	41.24 QP	46.00	-4.76	1.04 H	123	14.33	26.91
7	999.98	36.72 QP	54.00	-17.28	1.09 H	251	5.98	30.74
ANTENNA POLARITY & TEST DISTANCE: VERTICAL AT 3 M								
NO.	FREQ. (MHz)	EMISSION LEVEL (dBuV/m)	LIMIT (dBuV/m)	MARGIN (dB)	ANTENNA HEIGHT (m)	TABLE ANGLE (Degree)	RAW VALUE (dBuV)	CORRECTION FACTOR (dB/m)
1	44.96	32.73 QP	40.00	-7.27	1.04 V	148	17.94	14.79
2	132.00	27.46 QP	43.50	-16.04	1.12 V	227	13.67	13.79
3	250.00	34.93 QP	46.00	-11.07	1.04 V	86	20.68	14.25
4	650.00	36.43 QP	46.00	-9.57	1.04 V	259	10.90	25.53
5	875.00	35.49 QP	46.00	-10.51	1.12 V	234	6.20	29.29
6	999.98	37.42 QP	54.00	-16.58	1.35 V	122	6.68	30.74

- REMARKS:**
1. Emission level (dBuV/m) = Raw Value (dBuV) + Correction Factor (dB/m).
  2. Correction Factor (dB/m) = Antenna Factor (dB/m) + Cable Factor (dB).
  3. The other emission levels were very low against the limit.
  4. Margin value = Emission level – Limit value.



A D T

## ABOVE 1GHz WORST-CASE DATA

### 802.11b DSSS MODULATION

EUT TEST CONDITION		MEASUREMENT DETAIL	
CHANNEL	Channel 1	FREQUENCY RANGE	1 ~ 25GHz
INPUT POWER	120Vac, 60 Hz	DETECTOR FUNCTION	Peak (PK) Average (AV)
ENVIRONMENTAL CONDITIONS	30.0deg. C, 55.0%RH 965hPa	TESTED BY	Eric Lee

ANTENNA POLARITY & TEST DISTANCE: HORIZONTAL AT 3 M								
NO.	FREQ. (MHz)	EMISSION LEVEL (dBuV/m)	LIMIT (dBuV/m)	MARGIN (dB)	ANTENNA HEIGHT (m)	TABLE ANGLE (Degree)	RAW VALUE (dBuV)	CORRECTION FACTOR (dB/m)
1	2390.00	54.08 PK	74.00	-19.92	1.00 H	239	24.02	30.06
2	2390.00	43.64 AV	54.00	-10.36	1.00 H	239	13.58	30.06
3	*2412.00	103.80 PK			1.02 H	257	73.65	30.15
4	*2412.00	99.10 AV			1.02 H	257	68.95	30.15
5	4824.00	47.20 PK	74.00	-26.80	1.10 H	246	11.74	35.46
6	4824.00	31.27 AV	54.00	-22.73	1.10 H	246	-4.19	35.46
ANTENNA POLARITY & TEST DISTANCE: VERTICAL AT 3 M								
NO.	FREQ. (MHz)	EMISSION LEVEL (dBuV/m)	LIMIT (dBuV/m)	MARGIN (dB)	ANTENNA HEIGHT (m)	TABLE ANGLE (Degree)	RAW VALUE (dBuV)	CORRECTION FACTOR (dB/m)
1	2386.00	61.85 PK	74.00	-12.15	1.30 V	291	31.80	30.05
2	2386.00	53.38 AV	54.00	-0.62	1.30 V	291	23.33	30.05
3	*2412.00	121.52 PK			1.29 V	79	91.37	30.15
4	*2412.00	116.68 AV			1.29 V	79	86.53	30.15
5	4824.00	47.54 PK	74.00	-26.46	1.00 V	263	12.08	35.46
6	4824.00	33.84 AV	54.00	-20.16	1.00 V	263	-1.62	35.46

- REMARKS:**
1. Emission level (dBuV/m) = Raw Value (dBuV) + Correction Factor (dB/m).
  2. Correction Factor (dB/m) = Antenna Factor (dB/m) + Cable Factor (dB).
  3. The other emission levels were very low against the limit.
  4. Margin value = Emission level – Limit value.
  5. “ \* “: Fundamental frequency.



A D T

EUT TEST CONDITION		MEASUREMENT DETAIL	
CHANNEL	Channel 6	FREQUENCY RANGE	1 ~ 25GHz
INPUT POWER	120Vac, 60 Hz	DETECTOR FUNCTION	Peak (PK) Average (AV)
ENVIRONMENTAL CONDITIONS	30.0deg. C, 55.0%RH 965hPa	TESTED BY	Eric Lee

ANTENNA POLARITY & TEST DISTANCE: HORIZONTAL AT 3 M								
NO.	FREQ. (MHz)	EMISSION LEVEL (dBuV/m)	LIMIT (dBuV/m)	MARGIN (dB)	ANTENNA HEIGHT (m)	TABLE ANGLE (Degree)	RAW VALUE (dBuV)	CORRECTION FACTOR (dB/m)
1	*2437.00	106.30 PK			1.04 H	249	76.06	30.24
2	*2437.00	103.30 AV			1.04 H	249	73.06	30.24
3	2483.50	53.22 PK	74.00	-20.78	1.07 H	241	22.79	30.43
4	2483.50	43.82 AV	54.00	-10.18	1.07 H	241	13.39	30.43
5	4874.00	47.53 PK	74.00	-26.47	1.01 H	241	11.98	35.55
6	4874.00	33.44 AV	54.00	-20.56	1.01 H	241	-2.11	35.55
7	7311.00	51.60 PK	74.00	-22.40	1.07 H	26	9.56	42.04
8	7311.00	38.40 AV	54.00	-15.60	1.07 H	26	-3.64	42.04
ANTENNA POLARITY & TEST DISTANCE: VERTICAL AT 3 M								
NO.	FREQ. (MHz)	EMISSION LEVEL (dBuV/m)	LIMIT (dBuV/m)	MARGIN (dB)	ANTENNA HEIGHT (m)	TABLE ANGLE (Degree)	RAW VALUE (dBuV)	CORRECTION FACTOR (dB/m)
1	2390.00	63.83 PK	74.00	-10.17	1.21 V	99	33.77	30.06
2	2390.00	52.58 AV	54.00	-1.42	1.21 V	99	22.52	30.06
3	*2437.00	126.60 PK			1.22 V	99	96.36	30.24
4	*2437.00	121.86 AV			1.22 V	99	91.62	30.24
5	2483.50	65.29 PK	74.00	-8.71	1.28 V	2	34.86	30.43
6	2483.50	52.23 AV	54.00	-1.77	1.28 V	2	21.80	30.43
7	4874.00	48.38 PK	74.00	-25.62	1.00 V	24	12.83	35.55
8	4874.00	34.44 AV	54.00	-19.56	1.00 V	24	-1.11	35.55
9	7311.00	56.64 PK	74.00	-17.36	1.39 V	360	14.60	42.04
10	7311.00	45.48 AV	54.00	-8.52	1.39 V	360	3.44	42.04

- REMARKS:**
1. Emission level (dBuV/m) = Raw Value (dBuV) + Correction Factor (dB/m).
  2. Correction Factor (dB/m) = Antenna Factor (dB/m) + Cable Factor (dB).
  3. The other emission levels were very low against the limit.
  4. Margin value = Emission level – Limit value.
  5. “ \* “: Fundamental frequency.



A D T

EUT TEST CONDITION		MEASUREMENT DETAIL	
CHANNEL	Channel 11	FREQUENCY RANGE	1 ~ 25GHz
INPUT POWER	120Vac, 60 Hz	DETECTOR FUNCTION	Peak (PK) Average (AV)
ENVIRONMENTAL CONDITIONS	30.0deg. C, 55.0%RH 965hPa	TESTED BY	Eric Lee

**ANTENNA POLARITY & TEST DISTANCE: HORIZONTAL AT 3 M**

NO.	FREQ. (MHz)	EMISSION LEVEL (dBuV/m)	LIMIT (dBuV/m)	MARGIN (dB)	ANTENNA HEIGHT (m)	TABLE ANGLE (Degree)	RAW VALUE (dBuV)	CORRECTION FACTOR (dB/m)
1	*2462.00	104.20 PK			1.03 H	216	73.86	30.34
2	*2462.00	99.30 AV			1.03 H	216	68.96	30.34
3	2483.50	53.30 PK	74.00	-20.70	1.06 H	229	22.87	30.43
4	2483.50	43.08 AV	54.00	-10.92	1.06 H	229	12.65	30.43
5	4924.00	47.53 PK	74.00	-26.47	1.72 H	325	11.90	35.63
6	4924.00	34.48 AV	54.00	-19.52	1.72 H	325	-1.15	35.63
7	7386.00	51.90 PK	74.00	-22.10	1.47 H	45	9.67	42.23
8	7386.00	39.80 AV	54.00	-14.20	1.47 H	45	-2.43	42.23

**ANTENNA POLARITY & TEST DISTANCE: VERTICAL AT 3 M**

NO.	FREQ. (MHz)	EMISSION LEVEL (dBuV/m)	LIMIT (dBuV/m)	MARGIN (dB)	ANTENNA HEIGHT (m)	TABLE ANGLE (Degree)	RAW VALUE (dBuV)	CORRECTION FACTOR (dB/m)
1	*2462.00	121.95 PK			1.30 V	98	91.61	30.34
2	*2462.00	117.22 AV			1.30 V	98	86.88	30.34
3	2483.50	64.25 PK	74.00	-9.75	1.24 V	51	33.82	30.43
4	2483.50	53.49 AV	54.00	-0.51	1.24 V	51	23.06	30.43
5	4924.00	48.26 PK	74.00	-25.74	1.01 V	29	12.63	35.63
6	4924.00	34.13 AV	54.00	-19.87	1.01 V	29	-1.50	35.63
7	7386.00	54.52 PK	74.00	-19.48	1.25 V	87	12.29	42.23
8	7386.00	45.22 AV	54.00	-8.78	1.25 V	87	2.99	42.23

- REMARKS:**
1. Emission level (dBuV/m) = Raw Value (dBuV) + Correction Factor (dB/m).
  2. Correction Factor (dB/m) = Antenna Factor (dB/m) + Cable Factor (dB).
  3. The other emission levels were very low against the limit.
  4. Margin value = Emission level – Limit value.
  5. “ \* “: Fundamental frequency.



A D T

### RESTRICTED BANDEDGE (802.11b MODE,CH1, HORIZONTAL )

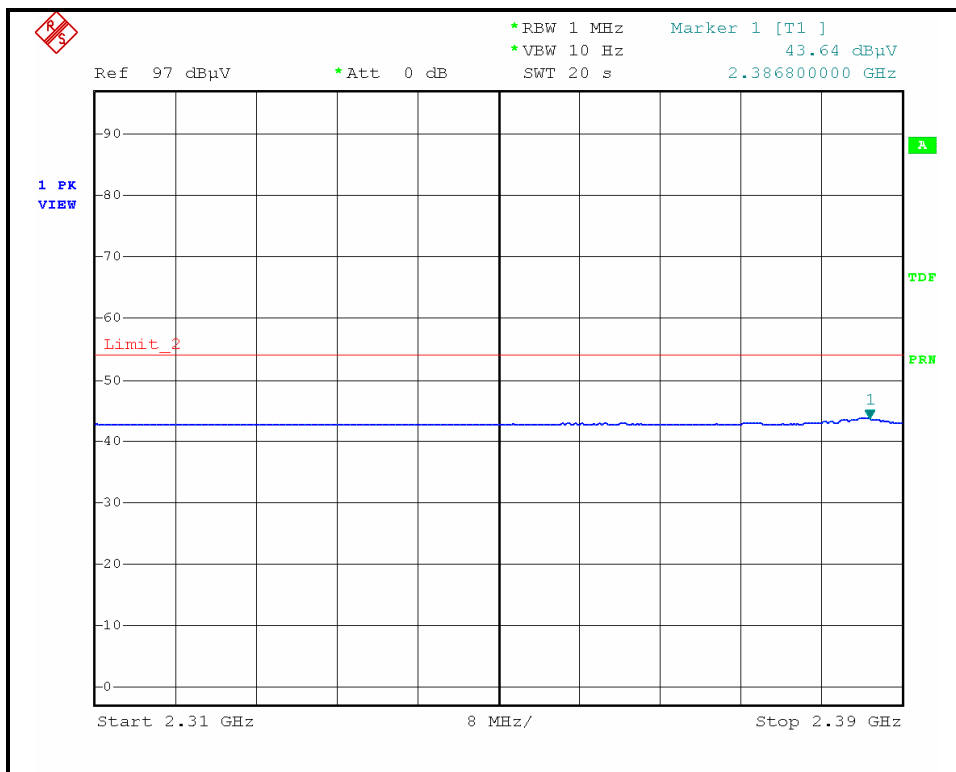
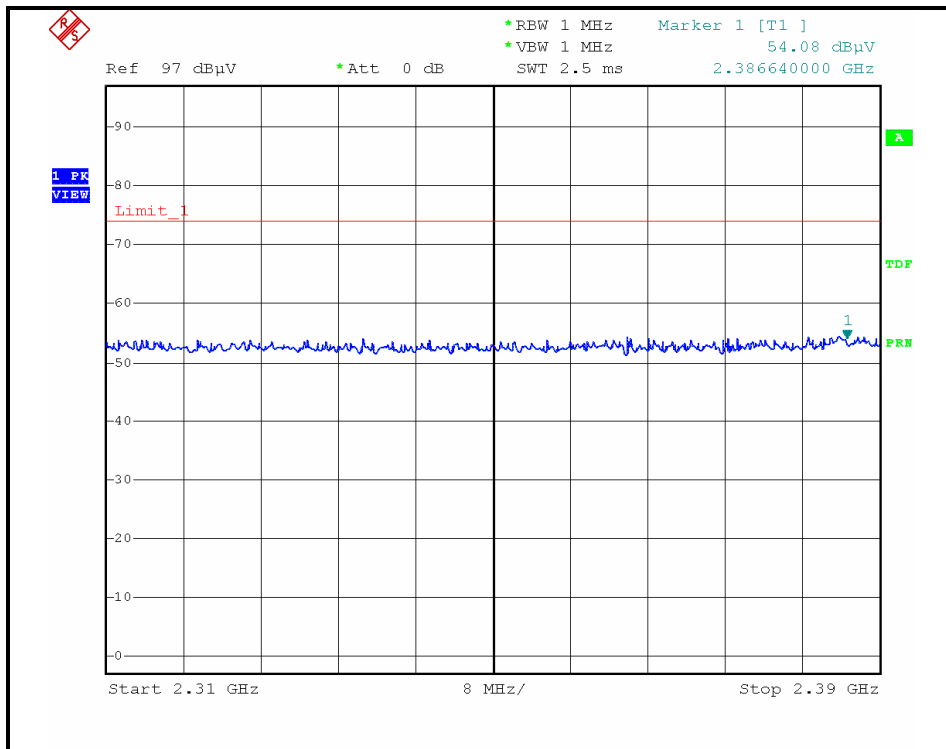



A D T

### RESTRICTED BANDEDGE (802.11b MODE,CH1, VERTICAL )

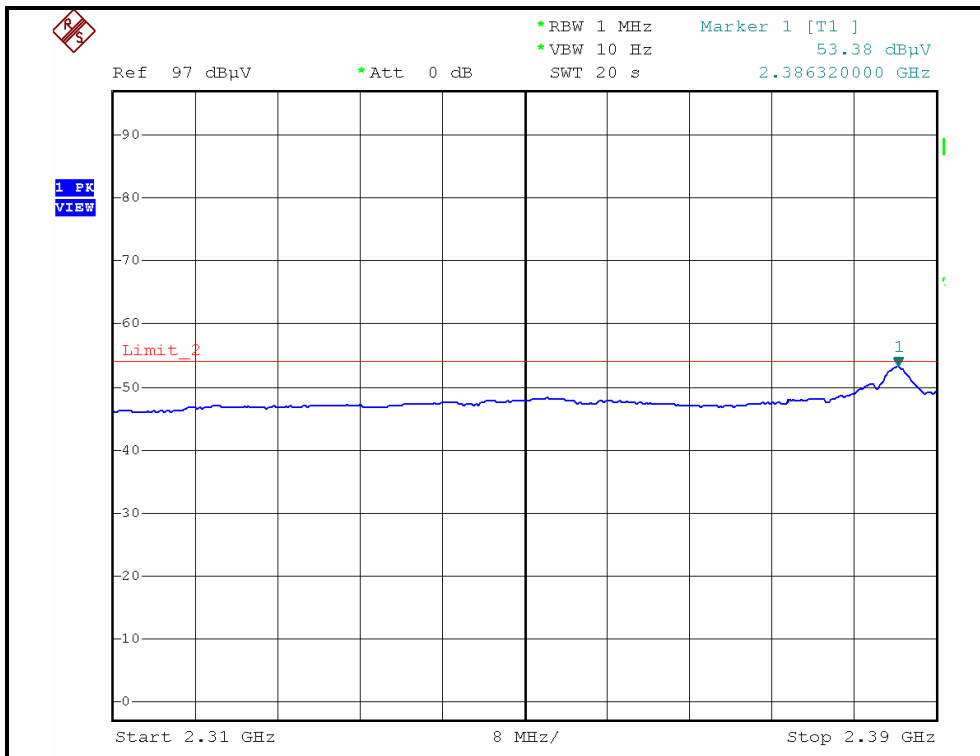
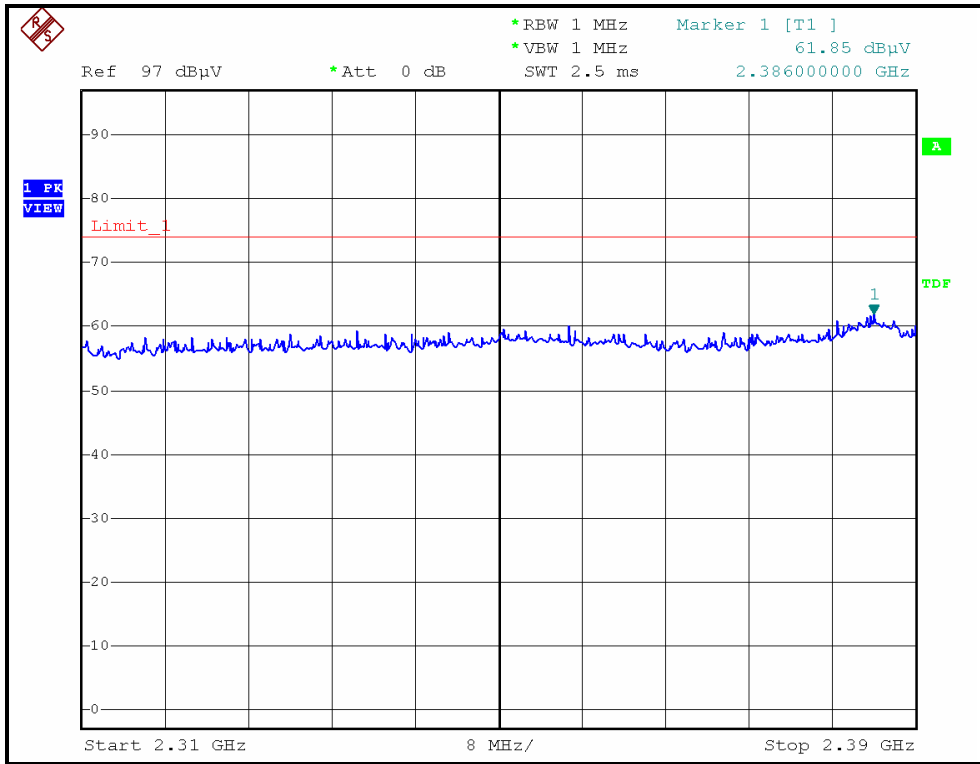





A D T

### RESTRICTED BANDEDGE (802.11b MODE,CH11, HORIZONTAL )

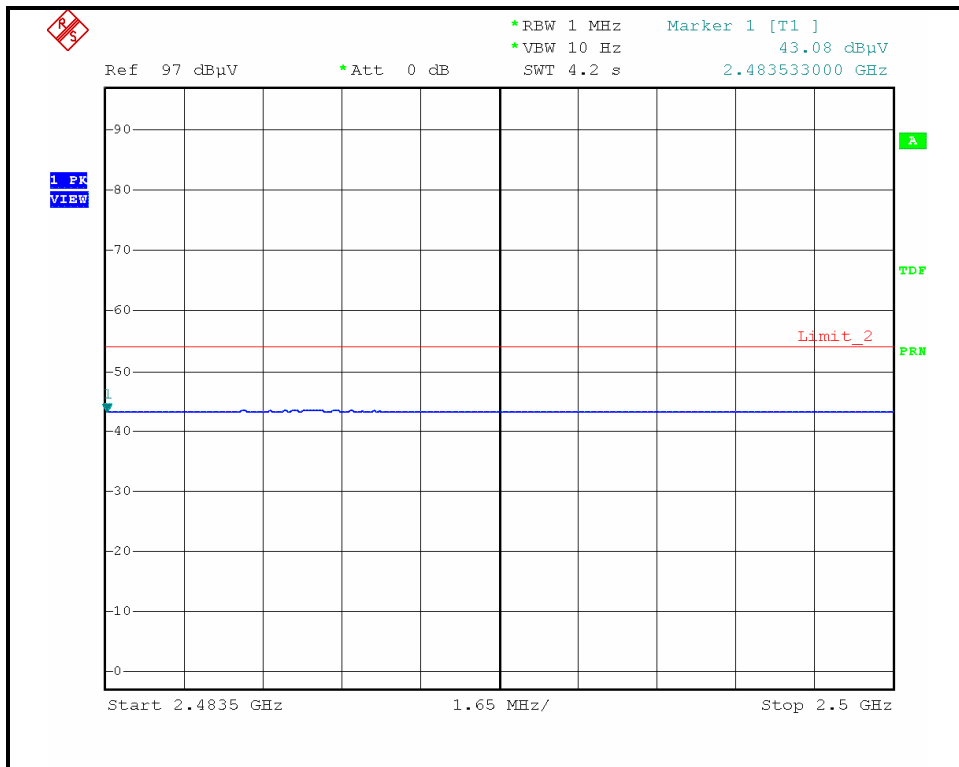
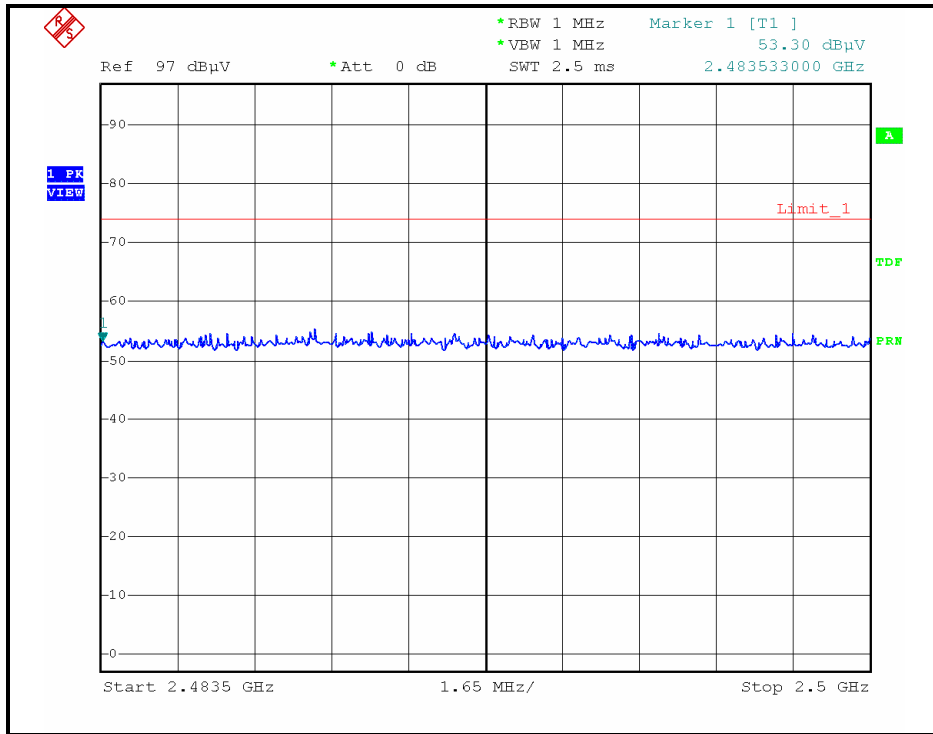



A D T

### RESTRICTED BANDEDGE (802.11b MODE, CH11, VERTICAL)

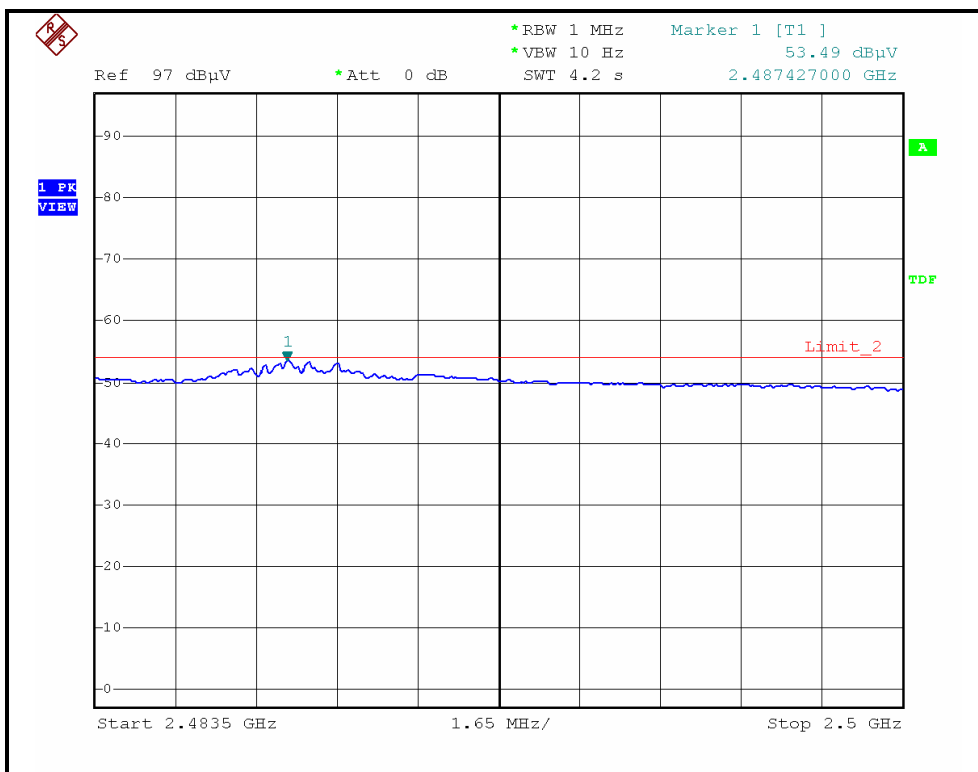
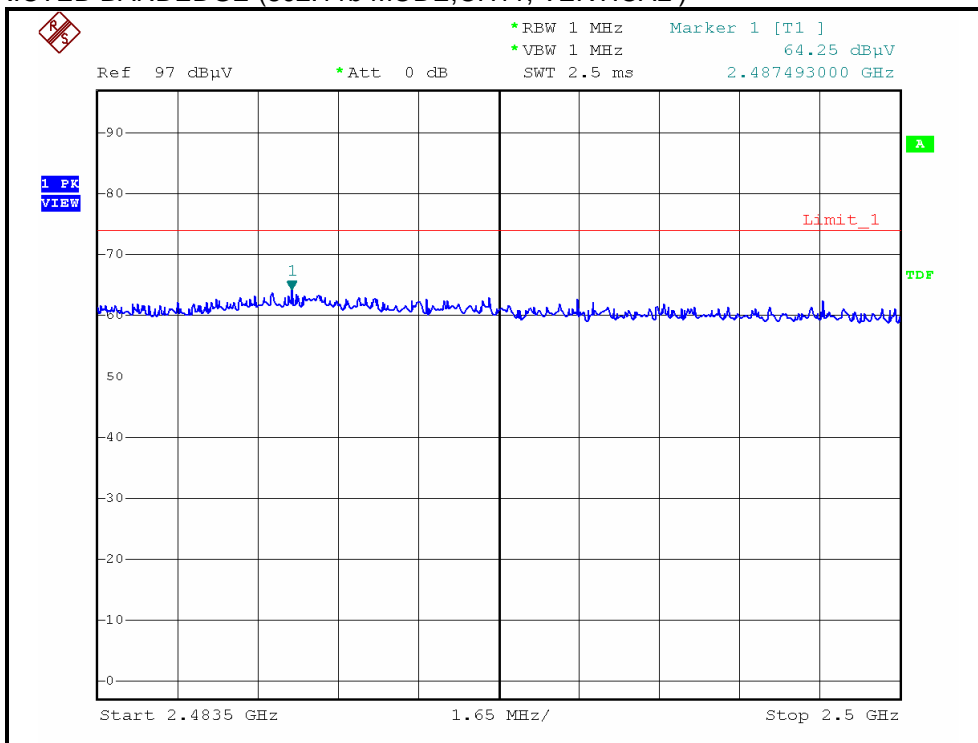



A D T

### 802.11g OFDM MODULATION

EUT TEST CONDITION		MEASUREMENT DETAIL	
CHANNEL	Channel 1	FREQUENCY RANGE	1 ~ 25GHz
INPUT POWER	120Vac, 60 Hz	DETECTOR FUNCTION	Peak (PK) Average (AV)
ENVIRONMENTAL CONDITIONS	30.0deg. C, 55.0%RH 965hPa	TESTED BY	Eric Lee

ANTENNA POLARITY & TEST DISTANCE: HORIZONTAL AT 3 M								
NO.	FREQ. (MHz)	EMISSION LEVEL (dBuV/m)	LIMIT (dBuV/m)	MARGIN (dB)	ANTENNA HEIGHT (m)	TABLE ANGLE (Degree)	RAW VALUE (dBuV)	CORRECTION FACTOR (dB/m)
1	2390.00	53.38 PK	74.00	-20.62	1.16 H	272	23.32	30.06
2	2390.00	42.74 AV	54.00	-11.26	1.16 H	272	12.68	30.06
3	*2412.00	100.60 PK			1.04 H	297	70.45	30.15
4	*2412.00	90.80 AV			1.04 H	297	60.65	30.15
5	4824.00	46.80 PK	74.00	-27.20	1.00 H	245	11.34	35.46
6	4824.00	32.90 AV	54.00	-21.10	1.00 H	245	-2.56	35.46
ANTENNA POLARITY & TEST DISTANCE: VERTICAL AT 3 M								
NO.	FREQ. (MHz)	EMISSION LEVEL (dBuV/m)	LIMIT (dBuV/m)	MARGIN (dB)	ANTENNA HEIGHT (m)	TABLE ANGLE (Degree)	RAW VALUE (dBuV)	CORRECTION FACTOR (dB/m)
1	2390.00	67.62 PK	74.00	-6.38	1.22 V	54	37.56	30.06
2	2390.00	52.87 AV	54.00	-1.13	1.22 V	54	22.81	30.06
3	*2412.00	120.18 PK			1.12 V	52	90.03	30.15
4	*2412.00	110.14 AV			1.12 V	52	79.99	30.15
5	4824.00	47.49 PK	74.00	-26.51	1.05 V	354	12.03	35.46
6	4824.00	33.87 AV	54.00	-20.13	1.05 V	354	-1.59	35.46

- REMARKS:**
1. Emission level (dBuV/m) = Raw Value (dBuV) + Correction Factor (dB/m).
  2. Correction Factor (dB/m) = Antenna Factor (dB/m) + Cable Factor (dB).
  3. The other emission levels were very low against the limit.
  4. Margin value = Emission level – Limit value.
  5. “ \* “: Fundamental frequency.



A D T

EUT TEST CONDITION		MEASUREMENT DETAIL	
CHANNEL	Channel 6	FREQUENCY RANGE	1 ~ 25GHz
INPUT POWER	120Vac, 60 Hz	DETECTOR FUNCTION	Peak (PK) Average (AV)
ENVIRONMENTAL CONDITIONS	30.0deg. C, 55.0%RH 965hPa	TESTED BY	Eric Lee

ANTENNA POLARITY & TEST DISTANCE: HORIZONTAL AT 3 M								
NO.	FREQ. (MHz)	EMISSION LEVEL (dBuV/m)	LIMIT (dBuV/m)	MARGIN (dB)	ANTENNA HEIGHT (m)	TABLE ANGLE (Degree)	RAW VALUE (dBuV)	CORRECTION FACTOR (dB/m)
1	2390.00	53.40 PK	74.00	-20.60	1.14 H	254	23.34	30.06
2	2390.00	42.30 AV	54.00	-11.70	1.14 H	254	12.24	30.06
3	*2437.00	103.10 PK			1.00 H	234	72.86	30.24
4	*2437.00	91.30 AV			1.00 H	234	61.06	30.24
5	4874.00	46.90 PK	74.00	-27.10	1.00 H	233	11.35	35.55
6	4874.00	32.80 AV	54.00	-21.20	1.00 H	233	-2.75	35.55
7	7311.00	52.30 PK	74.00	-21.70	1.02 H	214	10.26	42.04
8	7311.00	38.90 AV	54.00	-15.10	1.02 H	214	-3.14	42.04
ANTENNA POLARITY & TEST DISTANCE: VERTICAL AT 3 M								
NO.	FREQ. (MHz)	EMISSION LEVEL (dBuV/m)	LIMIT (dBuV/m)	MARGIN (dB)	ANTENNA HEIGHT (m)	TABLE ANGLE (Degree)	RAW VALUE (dBuV)	CORRECTION FACTOR (dB/m)
1	2390.00	64.38 PK	74.00	-9.62	1.17 V	49	34.32	30.06
2	2390.00	52.82 AV	54.00	-1.18	1.17 V	49	22.76	30.06
3	*2437.00	122.21 PK			1.15 V	49	91.97	30.24
4	*2437.00	111.58 AV			1.15 V	49	81.34	30.24
5	2483.50	64.36 PK	74.00	-9.64	1.21 V	97	33.93	30.43
6	2483.50	52.19 AV	54.00	-1.81	1.21 V	97	21.76	30.43
7	4874.00	47.66 PK	74.00	-26.34	1.00 V	298	12.11	35.55
8	4874.00	33.89 AV	54.00	-20.11	1.00 V	298	-1.66	35.55
9	7311.00	53.41 PK	74.00	-20.59	1.26 V	39	11.37	42.04
10	7311.00	39.73 AV	54.00	-14.27	1.26 V	39	-2.31	42.04

- REMARKS:**
1. Emission level (dBuV/m) = Raw Value (dBuV) + Correction Factor (dB/m).
  2. Correction Factor (dB/m) = Antenna Factor (dB/m) + Cable Factor (dB).
  3. The other emission levels were very low against the limit.
  4. Margin value = Emission level – Limit value.
  5. “ \* “: Fundamental frequency.



A D T

EUT TEST CONDITION		MEASUREMENT DETAIL	
CHANNEL	Channel 11	FREQUENCY RANGE	1 ~ 25GHz
INPUT POWER	120Vac, 60 Hz	DETECTOR FUNCTION	Peak (PK) Average (AV)
ENVIRONMENTAL CONDITIONS	30.0deg. C, 55.0%RH 965hPa	TESTED BY	Eric Lee

ANTENNA POLARITY & TEST DISTANCE: HORIZONTAL AT 3 M								
NO.	FREQ. (MHz)	EMISSION LEVEL (dBuV/m)	LIMIT (dBuV/m)	MARGIN (dB)	ANTENNA HEIGHT (m)	TABLE ANGLE (Degree)	RAW VALUE (dBuV)	CORRECTION FACTOR (dB/m)
1	*2462.00	104.20 PK			1.00 H	266	73.86	30.34
2	*2462.00	92.20 AV			1.00 H	266	61.86	30.34
3	2483.50	60.19 PK	74.00	-13.81	1.16 H	272	29.76	30.43
4	2483.50	45.31 AV	54.00	-8.69	1.16 H	272	14.88	30.43
5	4924.00	46.60 PK	74.00	-27.40	1.00 H	242	10.97	35.63
6	4924.00	32.60 AV	54.00	-21.40	1.00 H	242	-3.03	35.63
7	7386.00	53.10 PK	74.00	-20.90	1.10 H	36	10.87	42.23
8	7386.00	38.10 AV	54.00	-15.90	1.10 H	36	-4.13	42.23
ANTENNA POLARITY & TEST DISTANCE: VERTICAL AT 3 M								
NO.	FREQ. (MHz)	EMISSION LEVEL (dBuV/m)	LIMIT (dBuV/m)	MARGIN (dB)	ANTENNA HEIGHT (m)	TABLE ANGLE (Degree)	RAW VALUE (dBuV)	CORRECTION FACTOR (dB/m)
1	*2462.00	120.49 PK			1.14 V	122	90.15	30.34
2	*2462.00	109.55 AV			1.14 V	122	79.21	30.34
3	2483.50	70.21 PK	74.00	-3.79	1.24 V	51	39.78	30.43
4	2483.50	53.48 AV	54.00	-0.52	1.24 V	51	23.05	30.43
5	4924.00	47.25 PK	74.00	-26.75	1.25 V	32	11.62	35.63
6	4924.00	33.22 AV	54.00	-20.78	1.25 V	32	-2.41	35.63
7	7386.00	53.41 PK	74.00	-20.59	1.02 V	5	11.18	42.23
8	7386.00	39.68 AV	54.00	-14.32	1.02 V	5	-2.55	42.23

- REMARKS:**
1. Emission level (dBuV/m) = Raw Value (dBuV) + Correction Factor (dB/m).
  2. Correction Factor (dB/m) = Antenna Factor (dB/m) + Cable Factor (dB).
  3. The other emission levels were very low against the limit.
  4. Margin value = Emission level – Limit value.
  5. “ \* “: Fundamental frequency.



A D T

### RESTRICTED BANDEDGE (802.11g MODE,CH1, HORIZONTAL )

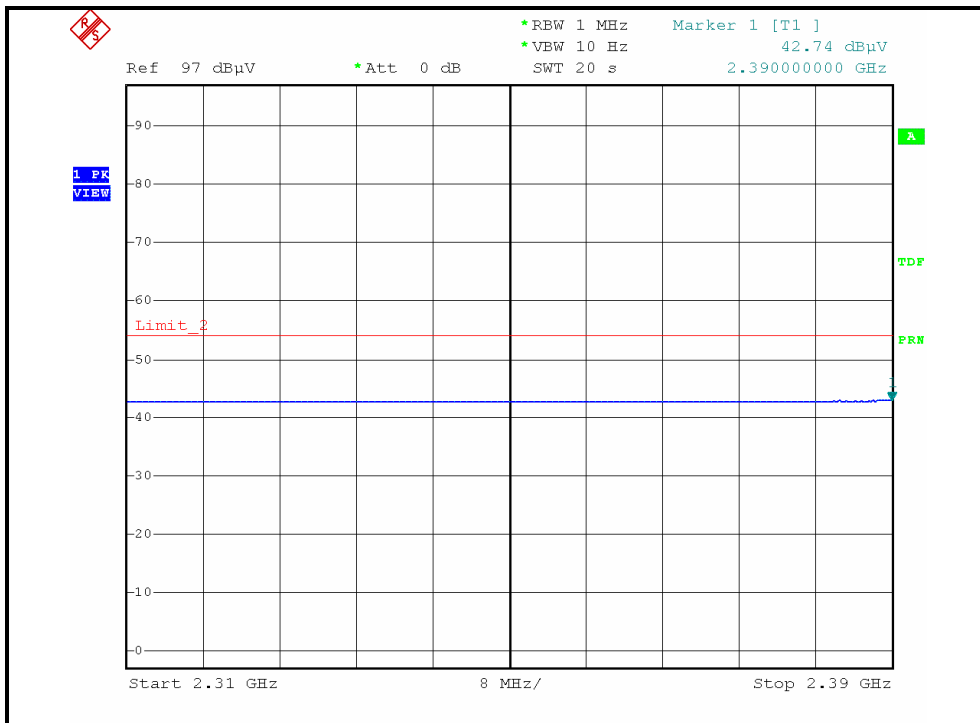
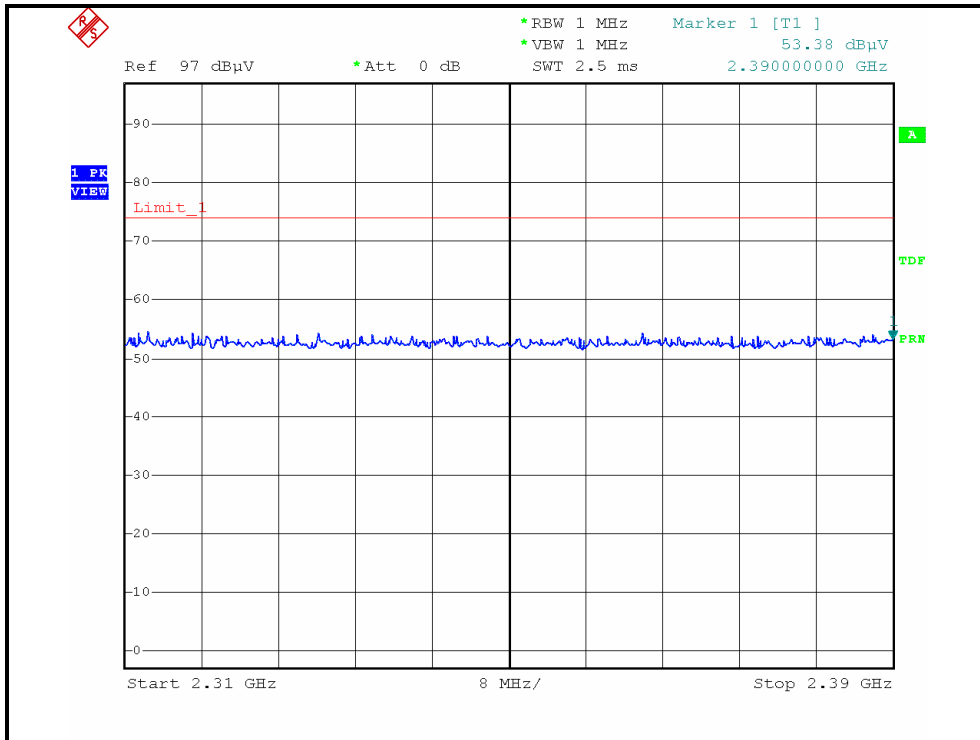



A D T

### RESTRICTED BANDEDGE (802.11g MODE,CH1, VERTICAL )

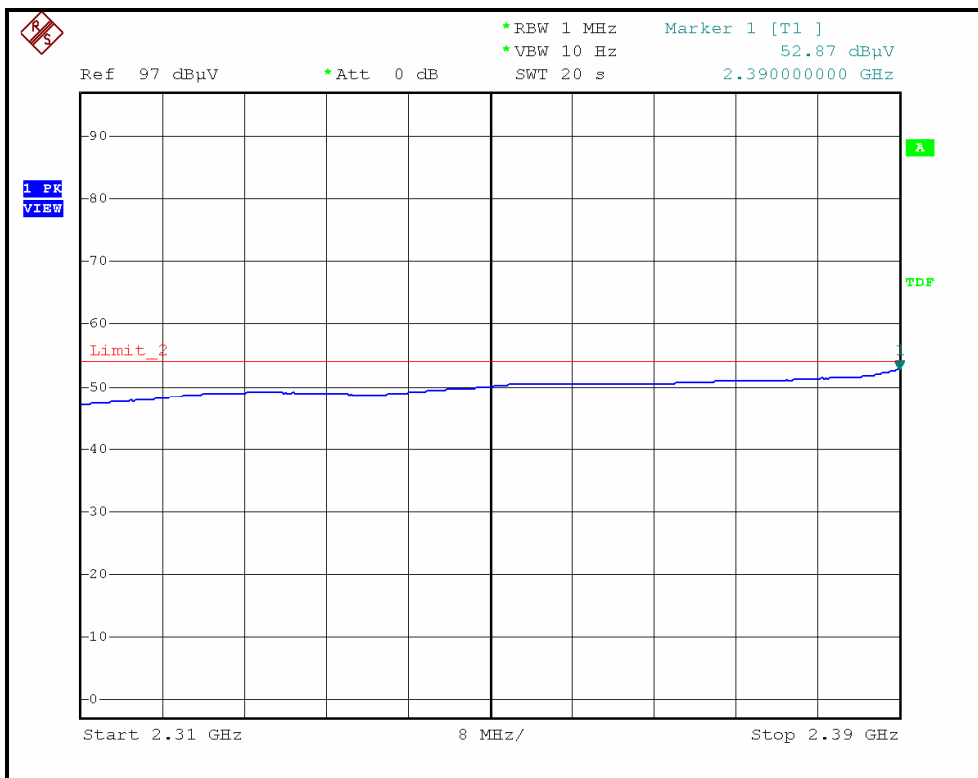
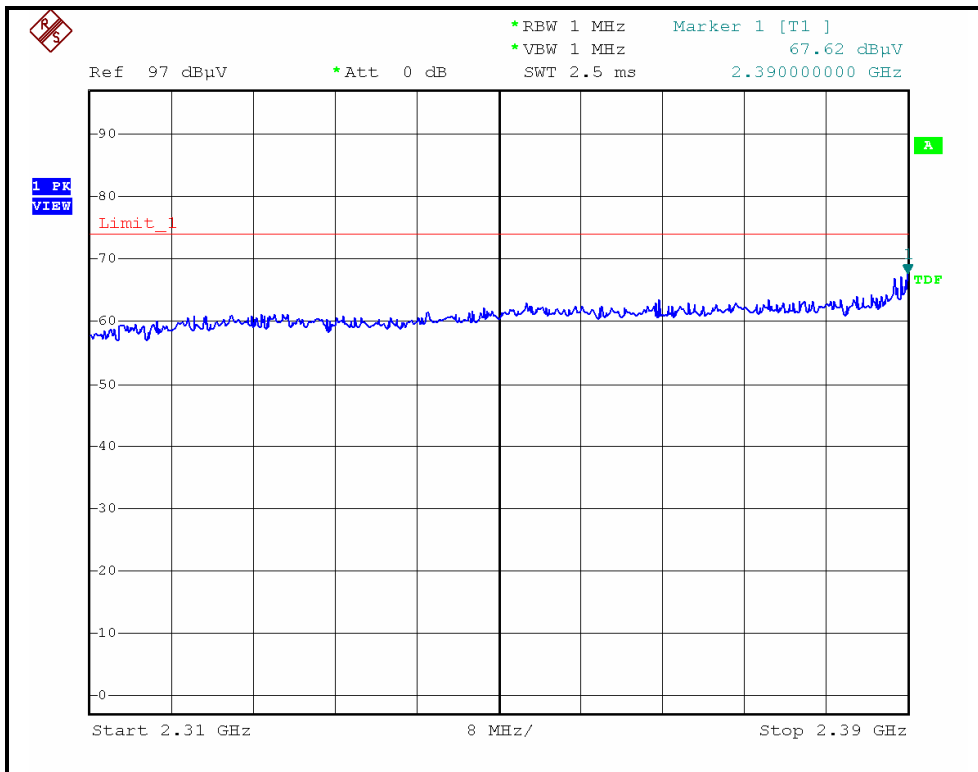



A D T

### RESTRICTED BANDEDGE (802.11g MODE,CH11, HORIZONTAL )

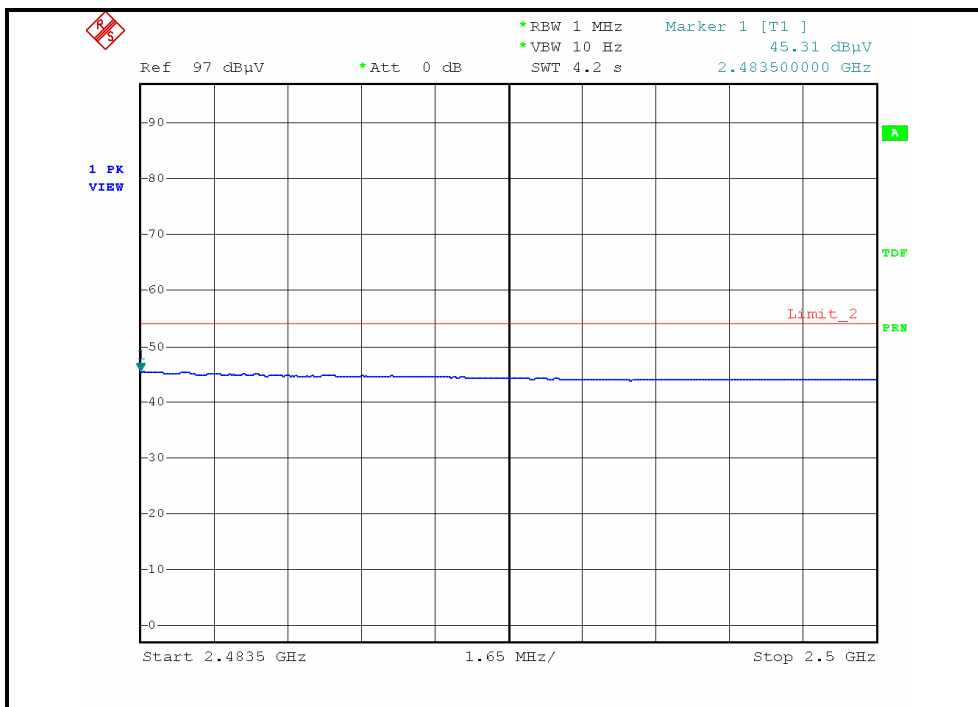
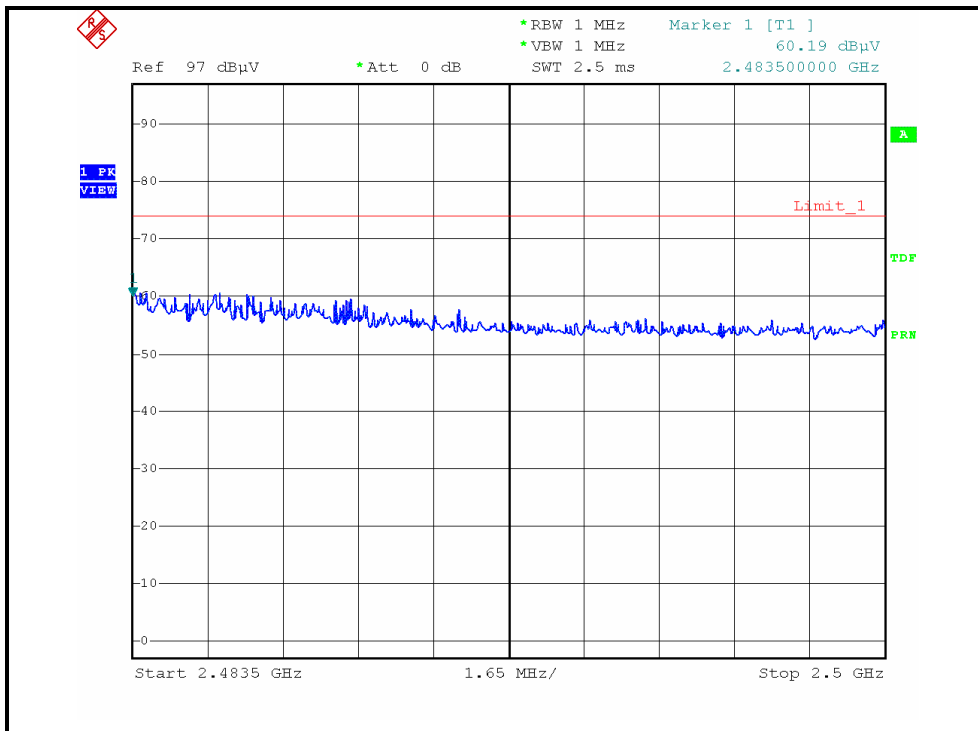





A D T

### RESTRICTED BANDEDGE (802.11g MODE,CH11, VERTICAL )

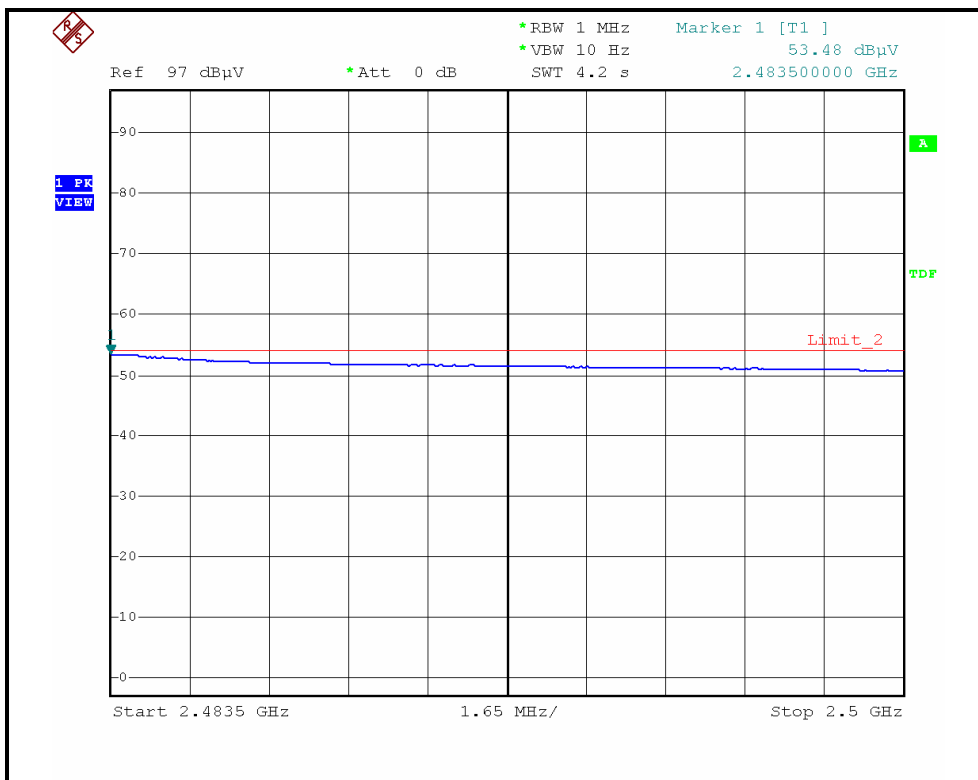
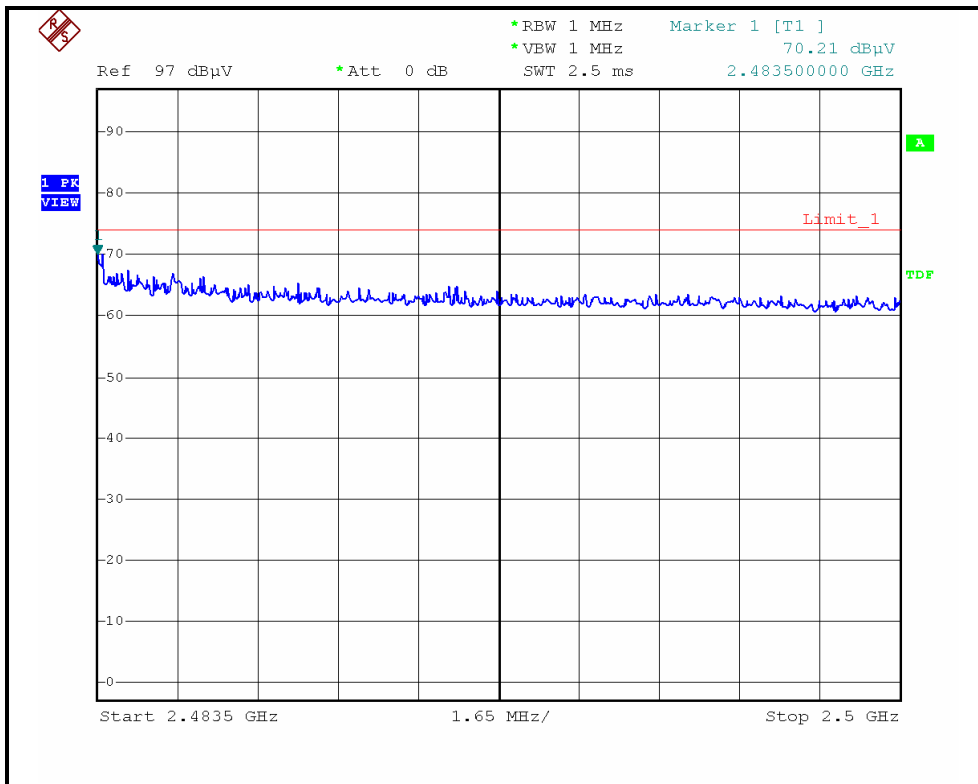



A D T

**DRAFT 802.11n (20MHz) OFDM MODULATION**

EUT TEST CONDITION		MEASUREMENT DETAIL	
CHANNEL	Channel 1	FREQUENCY RANGE	1 ~ 25GHz
INPUT POWER	120Vac, 60 Hz	DETECTOR FUNCTION	Peak (PK) Average (AV)
ENVIRONMENTAL CONDITIONS	30.0deg. C, 55.0%RH 965hPa	TESTED BY	Eric Lee

ANTENNA POLARITY & TEST DISTANCE: HORIZONTAL AT 3 M								
NO.	FREQ. (MHz)	EMISSION LEVEL (dBuV/m)	LIMIT (dBuV/m)	MARGIN (dB)	ANTENNA HEIGHT (m)	TABLE ANGLE (Degree)	RAW VALUE (dBuV)	CORRECTION FACTOR (dB/m)
1	2390.00	54.01 PK	74.00	-19.99	1.16 H	275	23.95	30.06
2	2390.00	43.11 AV	54.00	-10.89	1.16 H	275	13.05	30.06
3	*2412.00	100.40 PK			1.14 H	256	70.25	30.15
4	*2412.00	90.60 AV			1.14 H	256	60.45	30.15
5	4824.00	47.00 PK	74.00	-27.00	1.32 H	65	11.54	35.46
6	4824.00	30.80 AV	54.00	-23.20	1.32 H	65	-4.66	35.46
ANTENNA POLARITY & TEST DISTANCE: VERTICAL AT 3 M								
NO.	FREQ. (MHz)	EMISSION LEVEL (dBuV/m)	LIMIT (dBuV/m)	MARGIN (dB)	ANTENNA HEIGHT (m)	TABLE ANGLE (Degree)	RAW VALUE (dBuV)	CORRECTION FACTOR (dB/m)
1	2390.00	72.79 PK	74.00	-1.21	1.25 V	24	42.73	30.06
2	2390.00	53.40 AV	54.00	-0.60	1.25 V	24	23.34	30.06
3	*2412.00	120.53 PK			1.16 V	54	90.38	30.15
4	*2412.00	110.57 AV			1.16 V	54	80.42	30.15
5	4824.00	49.52 PK	74.00	-24.48	1.02 V	360	14.06	35.46
6	4824.00	33.89 AV	54.00	-20.11	1.02 V	360	-1.57	35.46

- REMARKS:**
1. Emission level (dBuV/m) = Raw Value (dBuV) + Correction Factor (dB/m).
  2. Correction Factor (dB/m) = Antenna Factor (dB/m) + Cable Factor (dB).
  3. The other emission levels were very low against the limit.
  4. Margin value = Emission level – Limit value.
  5. “ \* “: Fundamental frequency.



A D T

EUT TEST CONDITION		MEASUREMENT DETAIL	
CHANNEL	Channel 6	FREQUENCY RANGE	1 ~ 25GHz
INPUT POWER	120Vac, 60 Hz	DETECTOR FUNCTION	Peak (PK) Average (AV)
ENVIRONMENTAL CONDITIONS	30.0deg. C, 55.0%RH 965hPa	TESTED BY	Eric Lee

**ANTENNA POLARITY & TEST DISTANCE: HORIZONTAL AT 3 M**

NO.	FREQ. (MHz)	EMISSION LEVEL (dBuV/m)	LIMIT (dBuV/m)	MARGIN (dB)	ANTENNA HEIGHT (m)	TABLE ANGLE (Degree)	RAW VALUE (dBuV)	CORRECTION FACTOR (dB/m)
1	*2437.00	100.80 PK			1.16 H	254	70.56	30.24
2	*2437.00	91.20 AV			1.16 H	254	60.96	30.24
3	2483.50	53.60 PK	74.00	-20.40	1.12 H	262	23.17	30.43
4	2483.50	42.80 AV	54.00	-11.20	1.12 H	262	12.37	30.43
5	4874.00	47.20 PK	74.00	-26.80	1.00 H	257	11.65	35.55
6	4874.00	33.10 AV	54.00	-20.90	1.00 H	257	-2.45	35.55
7	7311.00	53.40 PK	74.00	-20.60	1.04 H	37	11.36	42.04
8	7311.00	39.30 AV	54.00	-14.70	1.04 H	37	-2.74	42.04

**ANTENNA POLARITY & TEST DISTANCE: VERTICAL AT 3 M**

NO.	FREQ. (MHz)	EMISSION LEVEL (dBuV/m)	LIMIT (dBuV/m)	MARGIN (dB)	ANTENNA HEIGHT (m)	TABLE ANGLE (Degree)	RAW VALUE (dBuV)	CORRECTION FACTOR (dB/m)
1	2390.00	65.12 PK	74.00	-8.88	1.14 V	42	35.06	30.06
2	2390.00	52.16 AV	54.00	-1.84	1.14 V	42	22.10	30.06
3	*2437.00	121.84 PK			1.15 V	43	91.60	30.24
4	*2437.00	111.43 AV			1.15 V	43	81.19	30.24
5	2483.50	64.91 PK	74.00	-9.09	1.02 V	24	34.48	30.43
6	2483.50	52.50 AV	54.00	-1.50	1.02 V	24	22.07	30.43
7	4874.00	47.63 PK	74.00	-26.37	1.02 V	24	12.08	35.55
8	4874.00	33.52 AV	54.00	-20.48	1.02 V	24	-2.03	35.55
9	7311.00	53.86 PK	74.00	-20.14	1.02 V	1	11.82	42.04
10	7311.00	39.68 AV	54.00	-14.32	1.02 V	1	-2.36	42.04

- REMARKS:**
1. Emission level (dBuV/m) = Raw Value (dBuV) + Correction Factor (dB/m).
  2. Correction Factor (dB/m) = Antenna Factor (dB/m) + Cable Factor (dB).
  3. The other emission levels were very low against the limit.
  4. Margin value = Emission level – Limit value.
  5. “ \* “: Fundamental frequency.



A D T

EUT TEST CONDITION		MEASUREMENT DETAIL	
CHANNEL	Channel 11	FREQUENCY RANGE	1 ~ 25GHz
INPUT POWER	120Vac, 60 Hz	DETECTOR FUNCTION	Peak (PK) Average (AV)
ENVIRONMENTAL CONDITIONS	30.0deg. C, 55.0%RH 965hPa	TESTED BY	Eric Lee

**ANTENNA POLARITY & TEST DISTANCE: HORIZONTAL AT 3 M**

NO.	FREQ. (MHz)	EMISSION LEVEL (dBuV/m)	LIMIT (dBuV/m)	MARGIN (dB)	ANTENNA HEIGHT (m)	TABLE ANGLE (Degree)	RAW VALUE (dBuV)	CORRECTION FACTOR (dB/m)
1	*2462.00	99.80 PK			1.12 H	24	69.46	30.34
2	*2462.00	89.30 AV			1.12 H	24	58.96	30.34
3	2483.50	54.72 PK	74.00	-19.28	1.16 H	272	24.29	30.43
4	2483.50	43.33 AV	54.00	-10.67	1.16 H	272	12.90	30.43
5	4924.00	47.60 PK	74.00	-26.40	1.00 H	234	11.97	35.63
6	4924.00	33.20 AV	54.00	-20.80	1.00 H	234	-2.43	35.63
7	7386.00	53.10 PK	74.00	-20.90	1.08 H	29	10.87	42.23
8	7386.00	38.40 AV	54.00	-15.60	1.08 H	29	-3.83	42.23

**ANTENNA POLARITY & TEST DISTANCE: VERTICAL AT 3 M**

NO.	FREQ. (MHz)	EMISSION LEVEL (dBuV/m)	LIMIT (dBuV/m)	MARGIN (dB)	ANTENNA HEIGHT (m)	TABLE ANGLE (Degree)	RAW VALUE (dBuV)	CORRECTION FACTOR (dB/m)
1	*2462.00	119.52 PK			1.14 V	352	89.18	30.34
2	*2462.00	108.93 AV			1.14 V	352	78.59	30.34
3	2483.50	71.42 PK	74.00	-2.58	1.14 V	350	40.99	30.43
4	2483.50	52.89 AV	54.00	-1.11	1.14 V	350	22.46	30.43
5	4924.00	47.69 PK	74.00	-26.31	1.20 V	67	12.06	35.63
6	4924.00	33.78 AV	54.00	-20.22	1.20 V	67	-1.85	35.63
7	7386.00	53.62 PK	74.00	-20.38	1.28 V	93	11.39	42.23
8	7386.00	39.81 AV	54.00	-14.19	1.28 V	93	-2.42	42.23

- REMARKS:**
1. Emission level (dBuV/m) = Raw Value (dBuV) + Correction Factor (dB/m).
  2. Correction Factor (dB/m) = Antenna Factor (dB/m) + Cable Factor (dB).
  3. The other emission levels were very low against the limit.
  4. Margin value = Emission level – Limit value.
  5. “ \* “: Fundamental frequency.



A D T

### RESTRICTED BANDEDGE (DRAFT 802.11n (20MHz) MODE, CH1, HORIZONTAL )

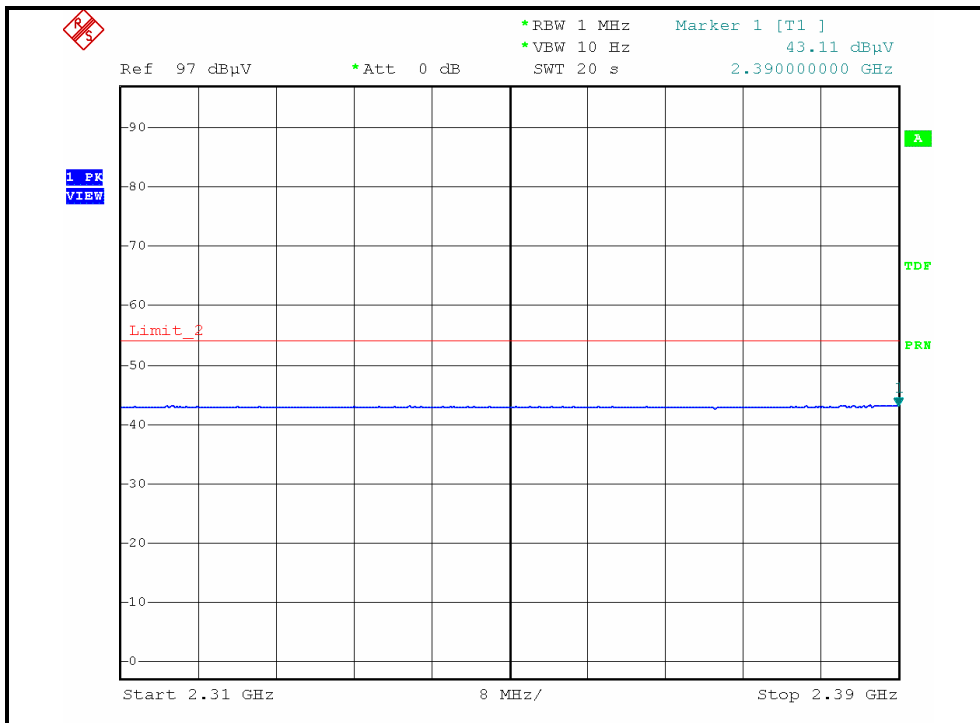
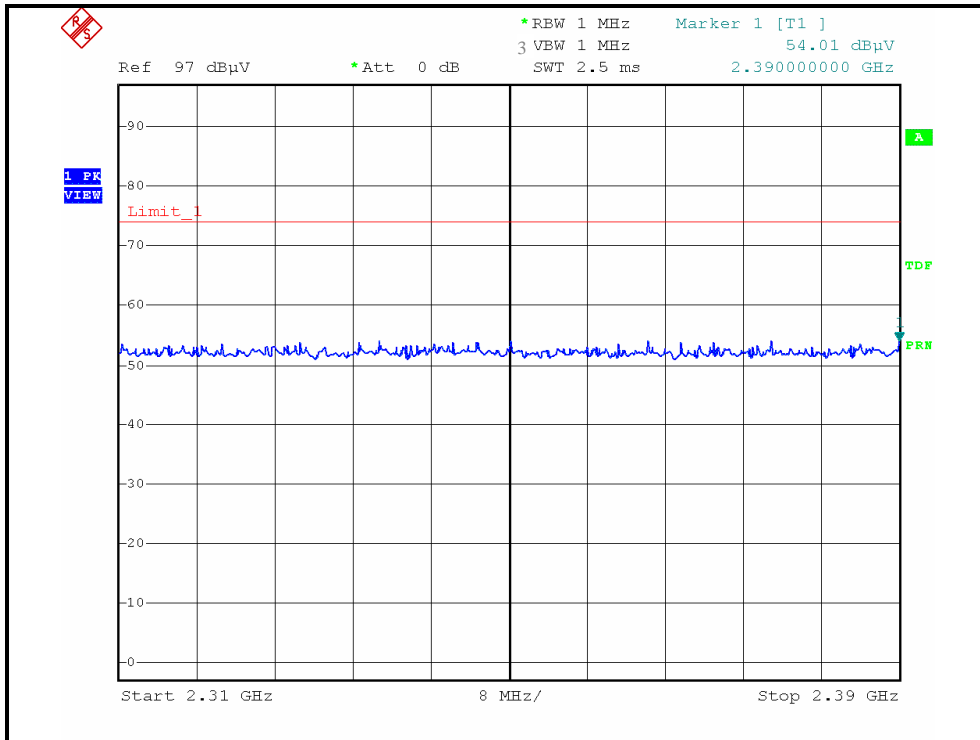



A D T

### RESTRICTED BANDEDGE (DRAFT 802.11n (20MHz) MODE,CH1, VERTICAL )

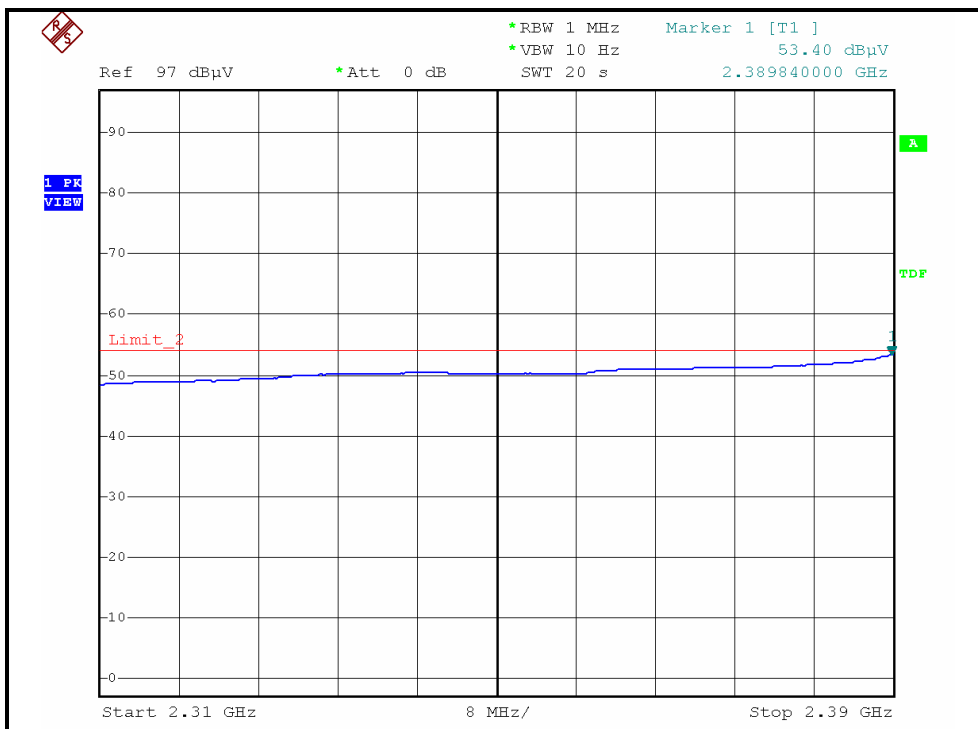
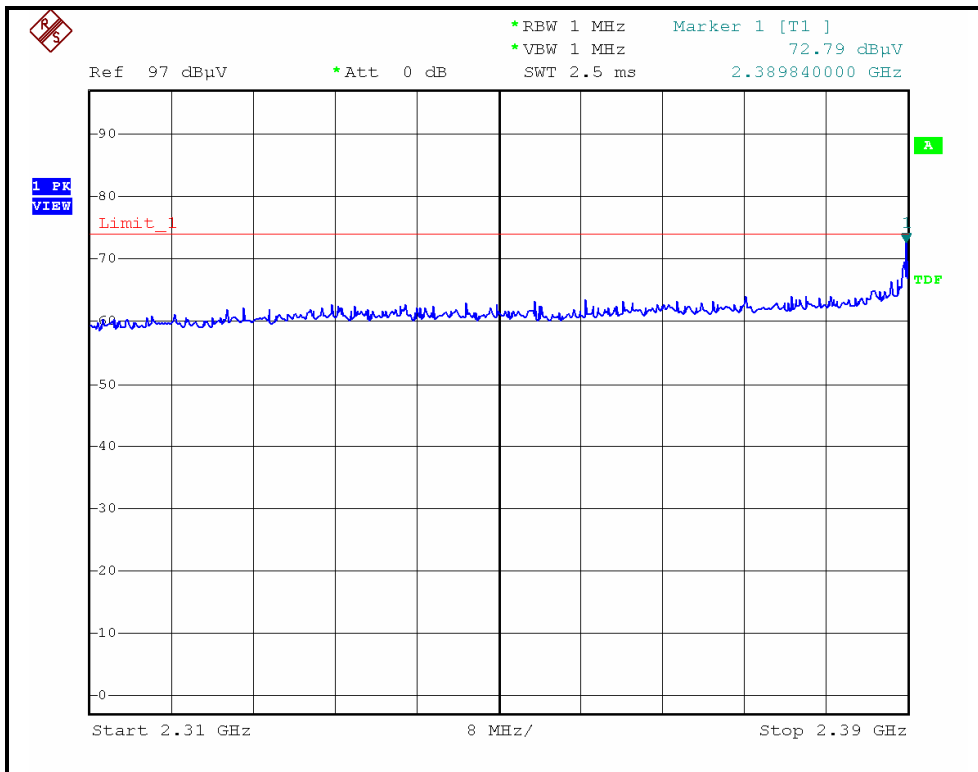



A D T

### RESTRICTED BANDEDGE (DRAFT 802.11n (20MHz) MODE,CH11, HORIZONTAL )

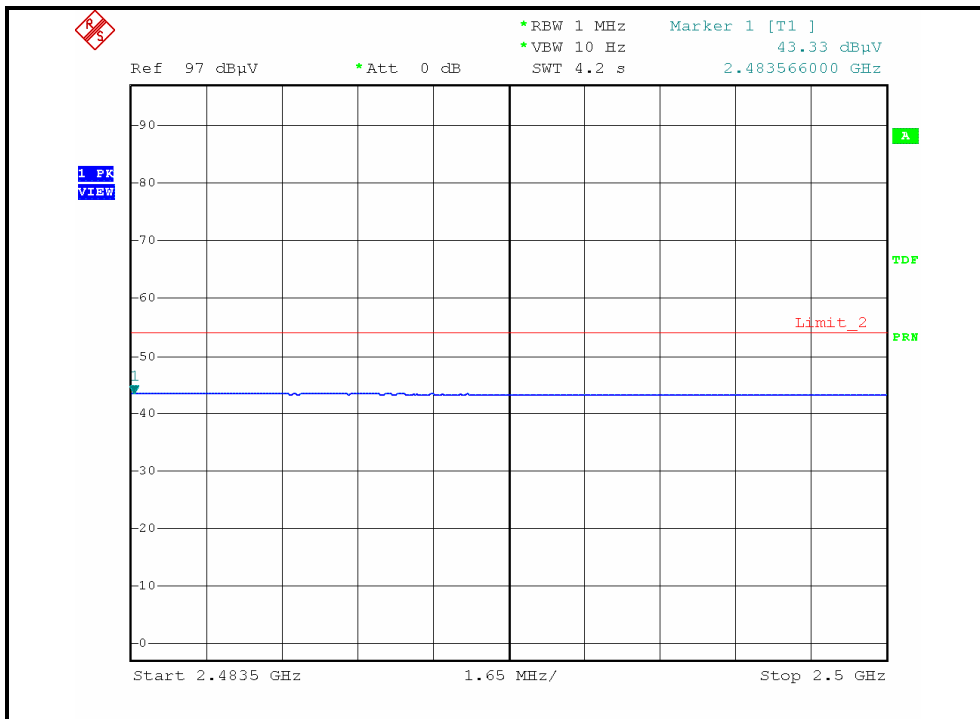
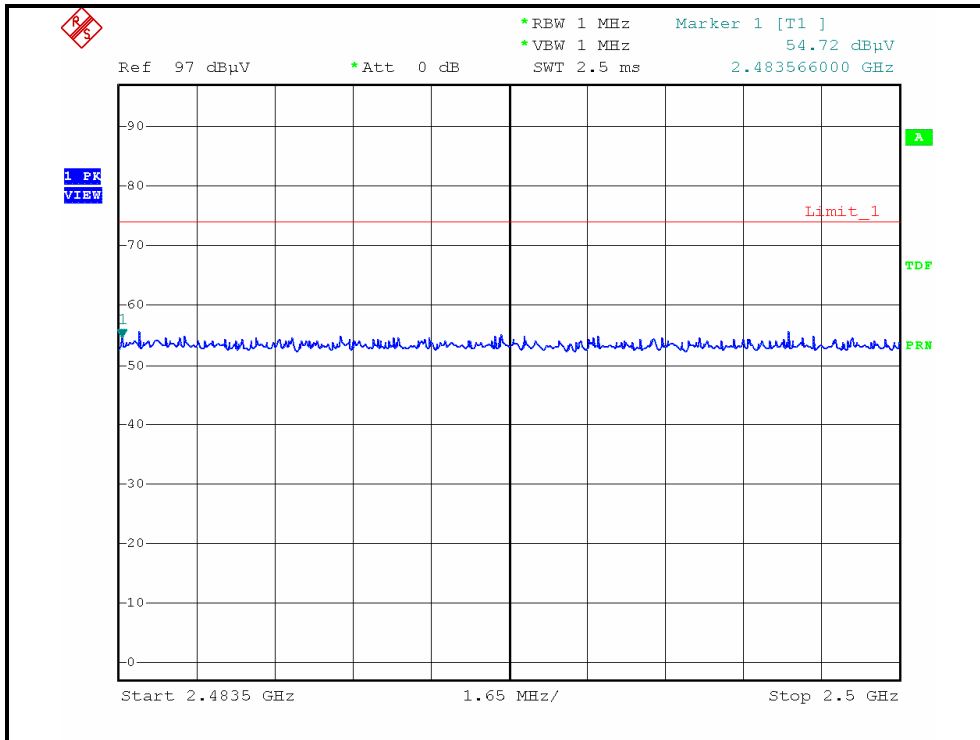



A D T

### RESTRICTED BANDEDGE (DRAFT 802.11n (20MHz) MODE,CH11, VERTICAL )

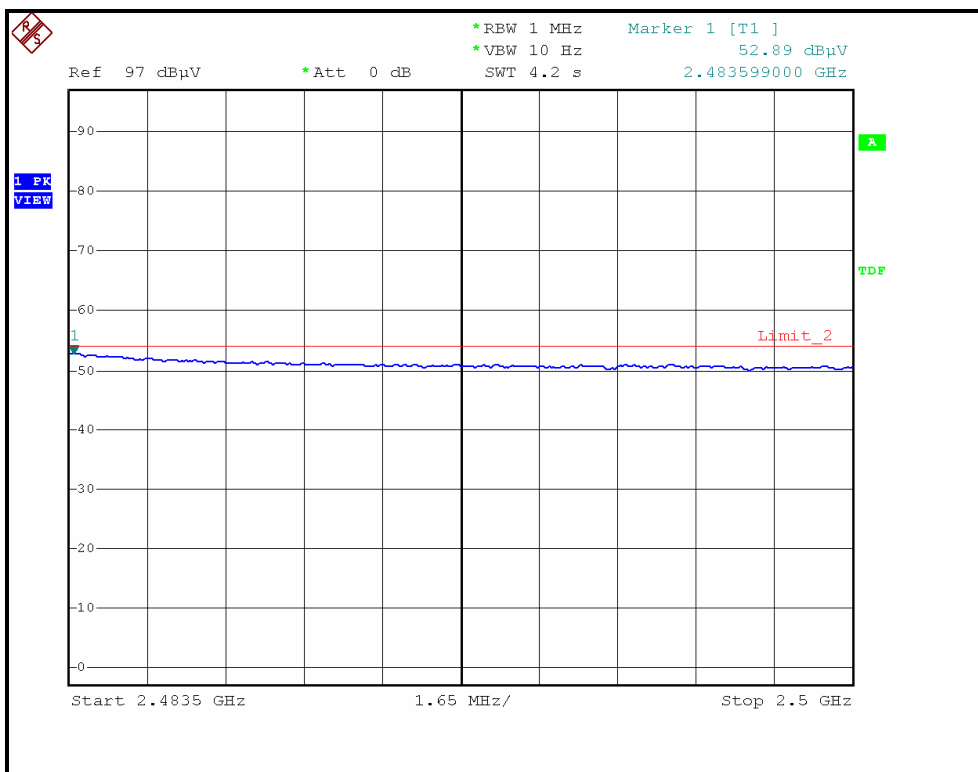
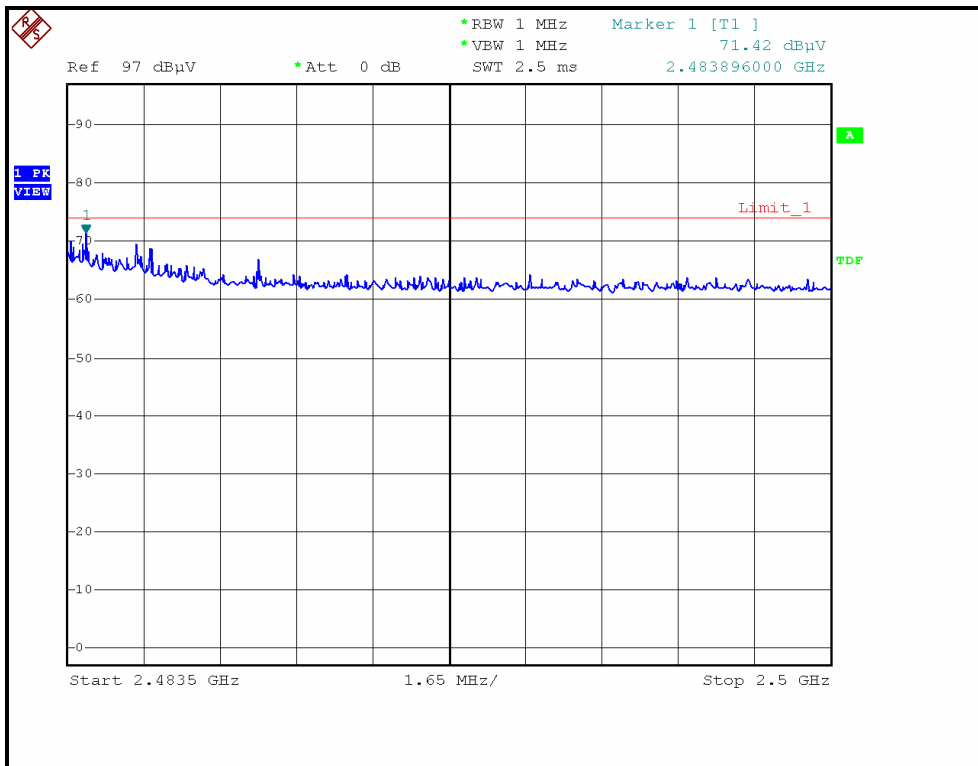





A D T

**DRAFT 802.11n (40MHz) OFDM MODULATION**

EUT TEST CONDITION		MEASUREMENT DETAIL	
CHANNEL	Channel 1	FREQUENCY RANGE	1 ~ 25GHz
INPUT POWER	120Vac, 60 Hz	DETECTOR FUNCTION	Peak (PK) Average (AV)
ENVIRONMENTAL CONDITIONS	30.0deg. C, 55.0%RH 965hPa	TESTED BY	Eric Lee

ANTENNA POLARITY & TEST DISTANCE: HORIZONTAL AT 3 M								
NO.	FREQ. (MHz)	EMISSION LEVEL (dBuV/m)	LIMIT (dBuV/m)	MARGIN (dB)	ANTENNA HEIGHT (m)	TABLE ANGLE (Degree)	RAW VALUE (dBuV)	CORRECTION FACTOR (dB/m)
1	2390.00	52.64 PK	74.00	-21.36	1.10 H	214	22.58	30.06
2	2390.00	42.66 AV	54.00	-11.34	1.10 H	214	12.60	30.06
3	*2422.00	93.60 PK			1.10 H	328	63.41	30.19
4	*2422.00	85.40 AV			1.10 H	328	55.21	30.19
5	4844.00	47.60 PK	74.00	-26.40	1.00 H	324	12.10	35.50
6	4844.00	33.50 AV	54.00	-20.50	1.00 H	324	-2.00	35.50
7	7266.00	53.60 PK	74.00	-20.40	1.02 H	241	11.67	41.93
8	7266.00	38.60 AV	54.00	-15.40	1.02 H	241	-3.33	41.93
ANTENNA POLARITY & TEST DISTANCE: VERTICAL AT 3 M								
NO.	FREQ. (MHz)	EMISSION LEVEL (dBuV/m)	LIMIT (dBuV/m)	MARGIN (dB)	ANTENNA HEIGHT (m)	TABLE ANGLE (Degree)	RAW VALUE (dBuV)	CORRECTION FACTOR (dB/m)
1	2390.00	71.39 PK	74.00	-2.61	1.21 V	40	41.33	30.06
2	2390.00	52.72 AV	54.00	-1.28	1.21 V	40	22.66	30.06
3	*2422.00	113.22 PK			1.34 V	132	83.03	30.19
4	*2422.00	102.42 AV			1.34 V	132	72.23	30.19
5	4844.00	47.83 PK	74.00	-26.17	1.00 V	27	12.33	35.50
6	4844.00	33.62 AV	54.00	-20.38	1.00 V	27	-1.88	35.50
7	7266.00	52.70 PK	74.00	-21.30	1.22 V	34	10.77	41.93
8	7266.00	38.40 AV	54.00	-15.60	1.22 V	34	-3.53	41.93

- REMARKS:**
1. Emission level (dBuV/m) = Raw Value (dBuV) + Correction Factor (dB/m).
  2. Correction Factor (dB/m) = Antenna Factor (dB/m) + Cable Factor (dB).
  3. The other emission levels were very low against the limit.
  4. Margin value = Emission level – Limit value.
  5. “ \* “: Fundamental frequency.



A D T

EUT TEST CONDITION		MEASUREMENT DETAIL	
CHANNEL	Channel 4	FREQUENCY RANGE	1 ~ 25GHz
INPUT POWER	120Vac, 60 Hz	DETECTOR FUNCTION	Peak (PK) Average (AV)
ENVIRONMENTAL CONDITIONS	30.0deg. C, 55.0%RH 965hPa	TESTED BY	Eric Lee

**ANTENNA POLARITY & TEST DISTANCE: HORIZONTAL AT 3 M**

NO.	FREQ. (MHz)	EMISSION LEVEL (dBuV/m)	LIMIT (dBuV/m)	MARGIN (dB)	ANTENNA HEIGHT (m)	TABLE ANGLE (Degree)	RAW VALUE (dBuV)	CORRECTION FACTOR (dB/m)
1	*2437.00	94.30 PK			1.14 H	236	64.06	30.24
2	*2437.00	86.20 AV			1.14 H	236	55.96	30.24
3	2483.50	53.40 PK	74.00	-20.60	1.14 H	243	22.97	30.43
4	2483.50	43.10 AV	54.00	-10.90	1.14 H	243	12.67	30.43
5	4874.00	47.40 PK	74.00	-26.60	1.00 H	256	11.85	35.55
6	4874.00	33.40 AV	54.00	-20.60	1.00 H	256	-2.15	35.55
7	7311.00	53.10 PK	74.00	-20.90	1.03 H	59	11.06	42.04
8	7311.00	39.40 AV	54.00	-14.60	1.03 H	59	-2.64	42.04

**ANTENNA POLARITY & TEST DISTANCE: VERTICAL AT 3 M**

NO.	FREQ. (MHz)	EMISSION LEVEL (dBuV/m)	LIMIT (dBuV/m)	MARGIN (dB)	ANTENNA HEIGHT (m)	TABLE ANGLE (Degree)	RAW VALUE (dBuV)	CORRECTION FACTOR (dB/m)
1	2390.00	64.47 PK	74.00	-9.53	1.26 V	96	34.41	30.06
2	2390.00	52.44 AV	54.00	-1.56	1.26 V	96	22.38	30.06
3	*2437.00	115.60 PK			1.26 V	99	85.36	30.24
4	*2437.00	104.56 AV			1.26 V	99	74.32	30.24
5	2483.50	64.70 PK	74.00	-9.30	1.17 V	14	34.27	30.43
6	2483.50	52.90 AV	54.00	-1.10	1.17 V	14	22.47	30.43
7	4874.00	47.75 PK	74.00	-26.25	1.05 V	45	12.20	35.55
8	4874.00	33.82 AV	54.00	-20.18	1.05 V	45	-1.73	35.55
9	7311.00	53.63 PK	74.00	-20.37	1.24 V	93	11.59	42.04
10	7311.00	39.51 AV	54.00	-14.49	1.24 V	93	-2.53	42.04

- REMARKS:**
1. Emission level (dBuV/m) = Raw Value (dBuV) + Correction Factor (dB/m).
  2. Correction Factor (dB/m) = Antenna Factor (dB/m) + Cable Factor (dB).
  3. The other emission levels were very low against the limit.
  4. Margin value = Emission level – Limit value.
  5. “ \* “: Fundamental frequency.



A D T

EUT TEST CONDITION		MEASUREMENT DETAIL	
CHANNEL	Channel 7	FREQUENCY RANGE	1 ~ 25GHz
INPUT POWER	120Vac, 60 Hz	DETECTOR FUNCTION	Peak (PK) Average (AV)
ENVIRONMENTAL CONDITIONS	30.0deg. C, 55.0%RH 965hPa	TESTED BY	Eric Lee

**ANTENNA POLARITY & TEST DISTANCE: HORIZONTAL AT 3 M**

NO.	FREQ. (MHz)	EMISSION LEVEL (dBuV/m)	LIMIT (dBuV/m)	MARGIN (dB)	ANTENNA HEIGHT (m)	TABLE ANGLE (Degree)	RAW VALUE (dBuV)	CORRECTION FACTOR (dB/m)
1	*2452.00	98.50 PK			1.15 H	207	68.20	30.30
2	*2452.00	84.90 AV			1.15 H	207	54.60	30.30
3	2483.50	58.74 PK	74.00	-15.26	1.10 H	209	28.31	30.43
4	2483.50	44.15 AV	54.00	-9.85	1.10 H	209	13.72	30.43
5	4904.00	47.10 PK	74.00	-26.90	1.00 H	254	11.50	35.60
6	4904.00	33.20 AV	54.00	-20.80	1.00 H	254	-2.40	35.60
7	7356.00	53.80 PK	74.00	-20.20	1.06 H	48	11.64	42.16
8	7356.00	39.70 AV	54.00	-14.30	1.06 H	48	-2.46	42.16

**ANTENNA POLARITY & TEST DISTANCE: VERTICAL AT 3 M**

NO.	FREQ. (MHz)	EMISSION LEVEL (dBuV/m)	LIMIT (dBuV/m)	MARGIN (dB)	ANTENNA HEIGHT (m)	TABLE ANGLE (Degree)	RAW VALUE (dBuV)	CORRECTION FACTOR (dB/m)
1	*2452.00	111.57 PK			1.18 V	9	81.27	30.30
2	*2452.00	101.59 AV			1.18 V	9	71.29	30.30
3	2483.50	72.36 PK	74.00	-1.64	1.18 V	10	41.93	30.43
4	2483.50	53.15 AV	54.00	-0.85	1.18 V	10	22.72	30.43
5	4904.00	47.51 PK	74.00	-26.49	1.26 V	78	11.91	35.60
6	4904.00	33.64 AV	54.00	-20.36	1.26 V	78	-1.96	35.60
7	7356.00	53.83 PK	74.00	-20.17	1.25 V	21	11.67	42.16
8	7356.00	39.91 AV	54.00	-14.09	1.25 V	21	-2.25	42.16

- REMARKS:**
1. Emission level (dBuV/m) = Raw Value (dBuV) + Correction Factor (dB/m).
  2. Correction Factor (dB/m) = Antenna Factor (dB/m) + Cable Factor (dB).
  3. The other emission levels were very low against the limit.
  4. Margin value = Emission level – Limit value.
  5. “ \* “: Fundamental frequency.



A D T

### RESTRICTED BANDEDGE (DRAFT 802.11n (40MHz) MODE, CH1, HORIZONTAL )

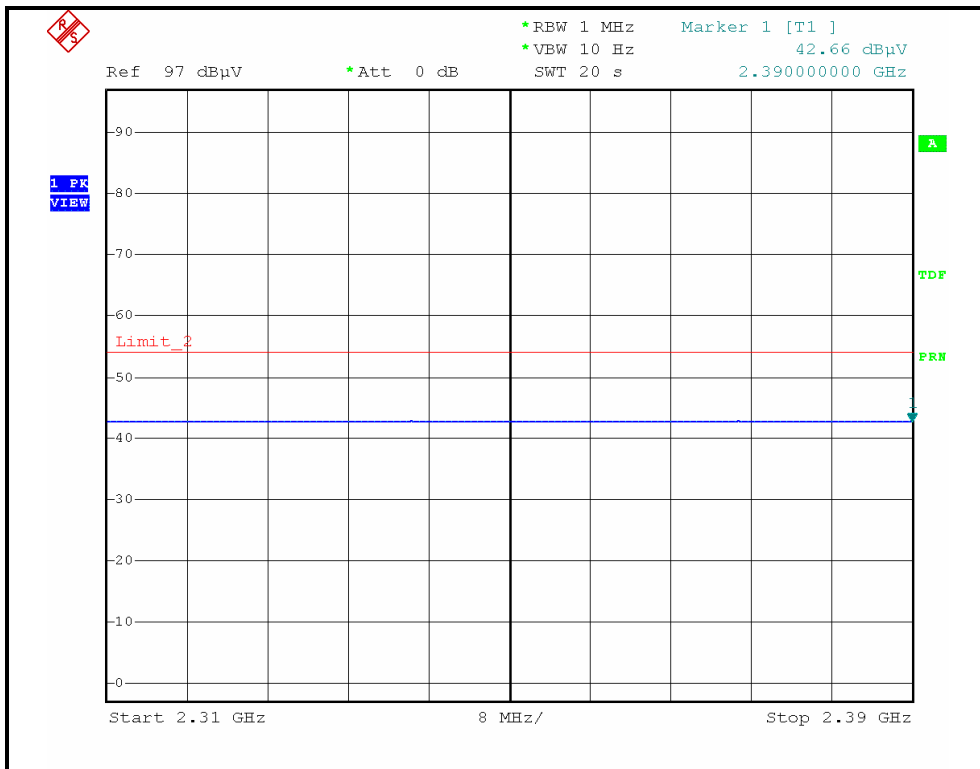
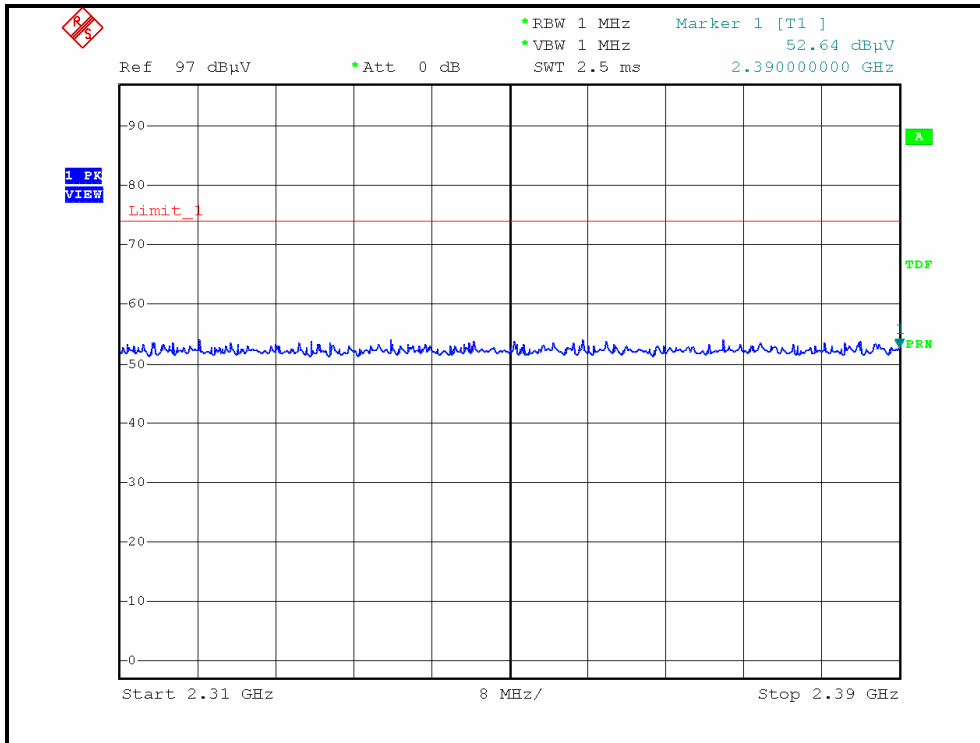



A D T

### RESTRICTED BANDEDGE (DRAFT 802.11n (40MHz) MODE,CH1, VERTICAL )

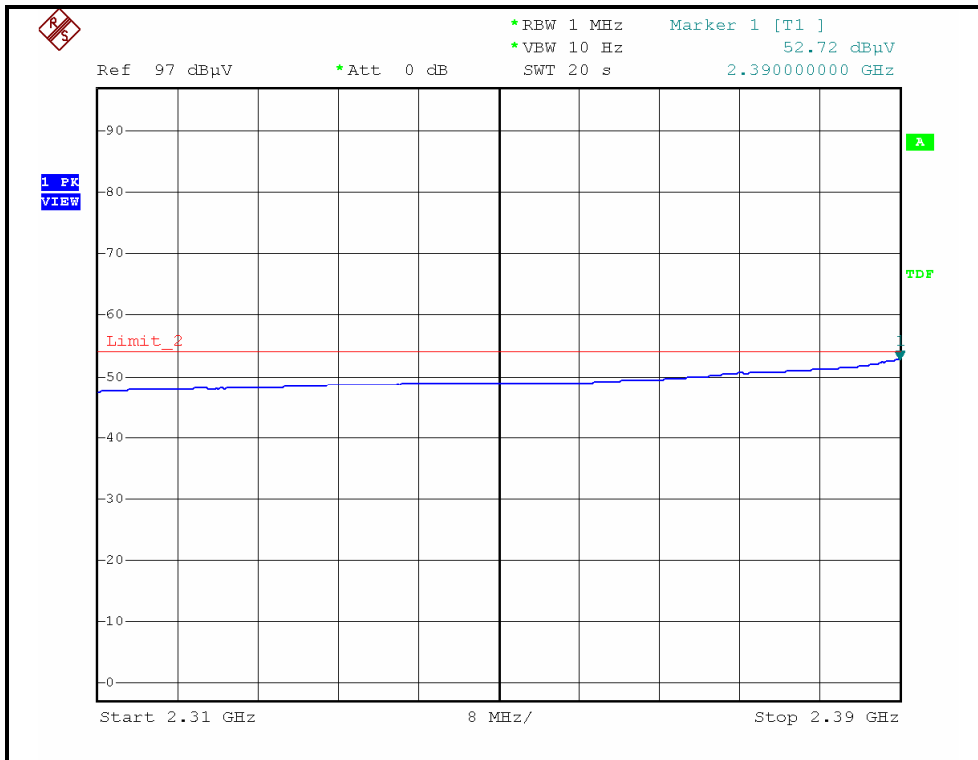
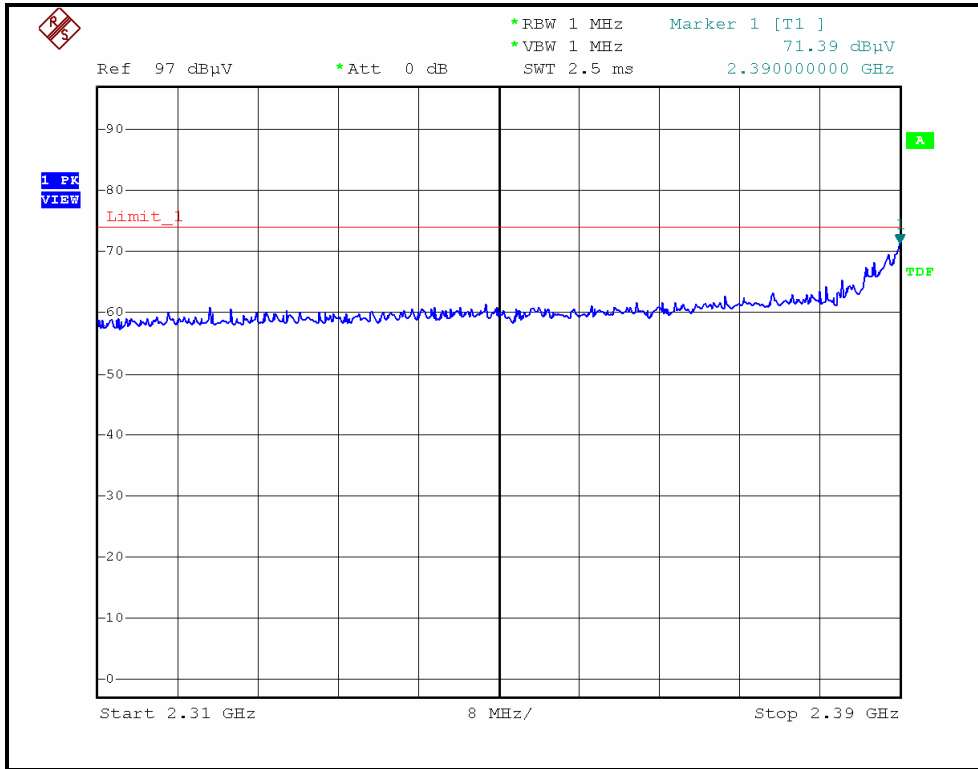



A D T

### RESTRICTED BANDEDGE (DRAFT 802.11n (40MHz) MODE,CH7, HORIZONTAL )

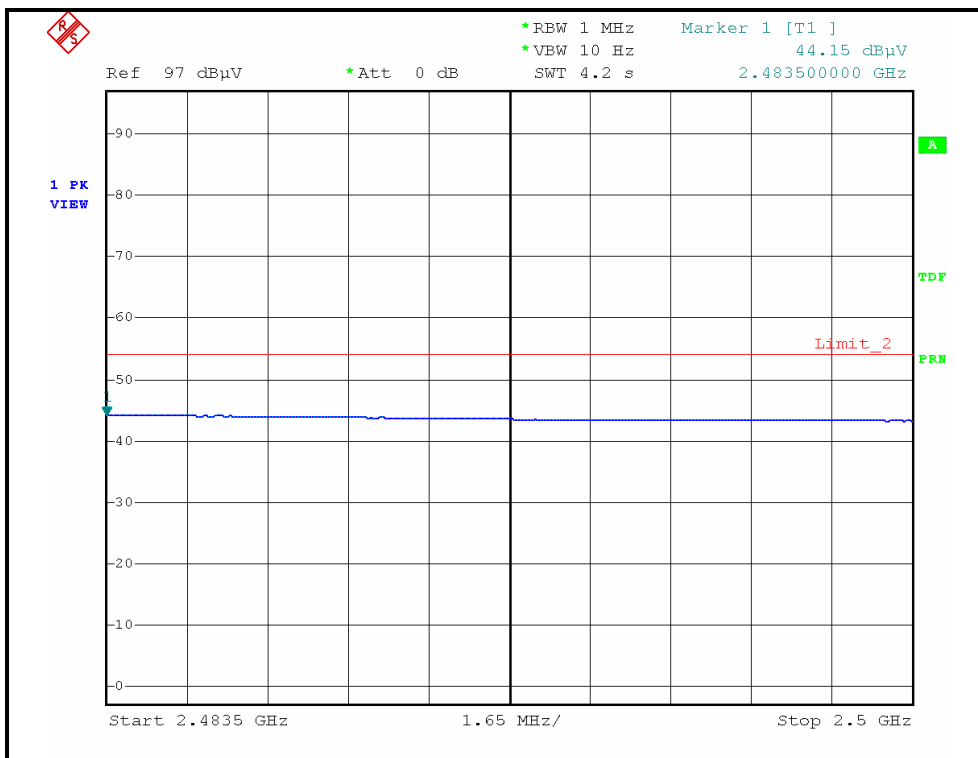
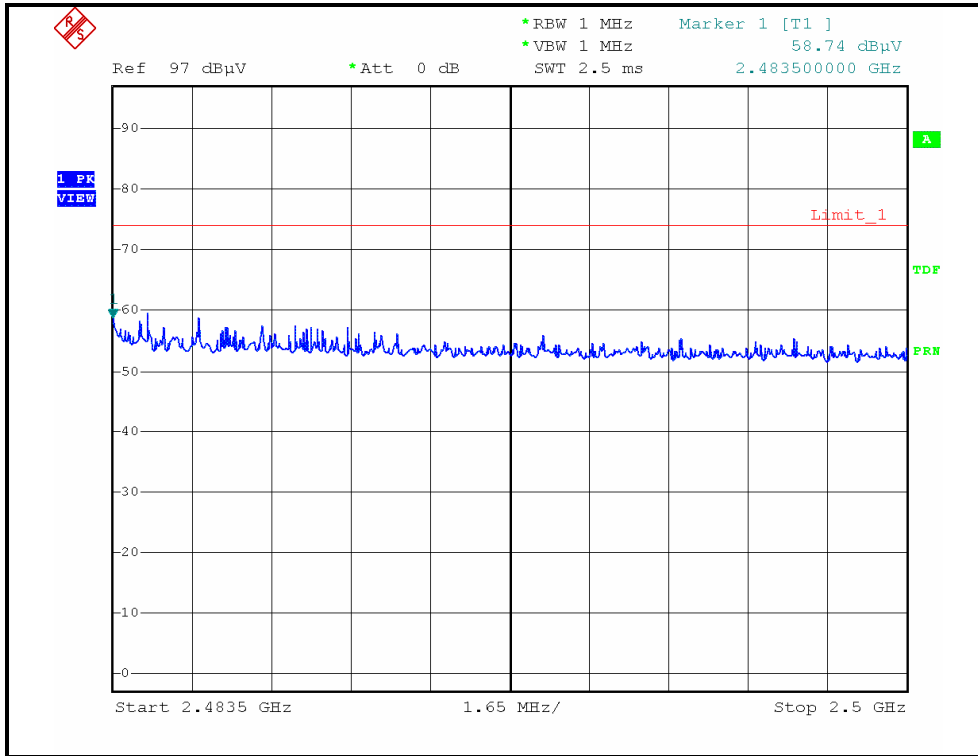



A D T

### RESTRICTED BANDEDGE (DRAFT 802.11n (40MHz) MODE,CH7, VERTICAL )

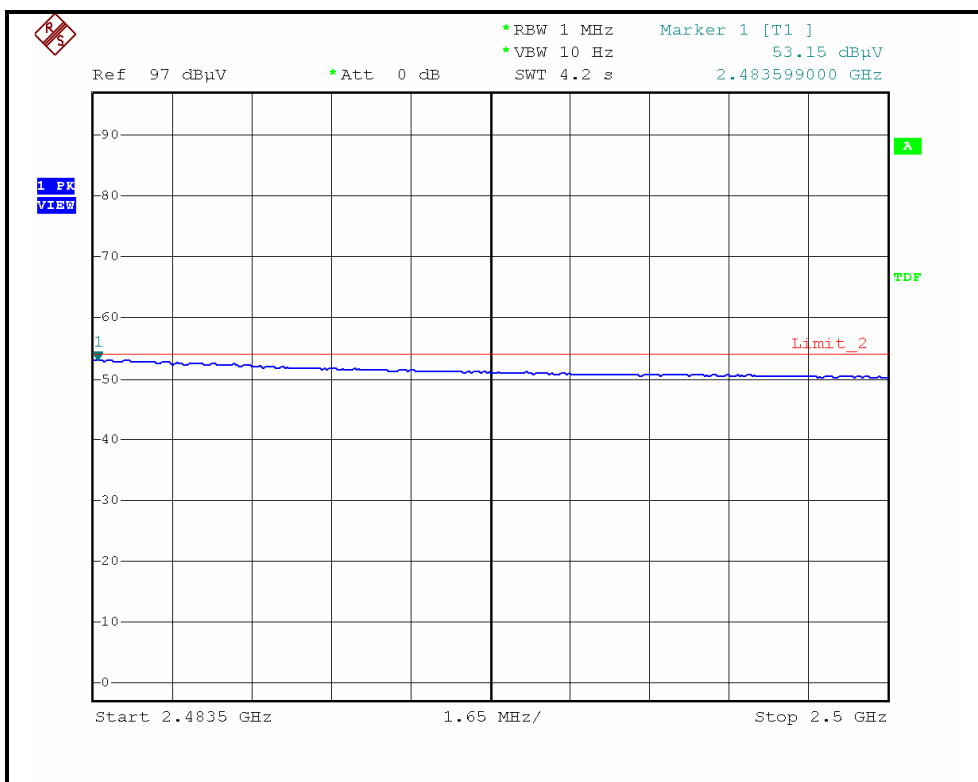
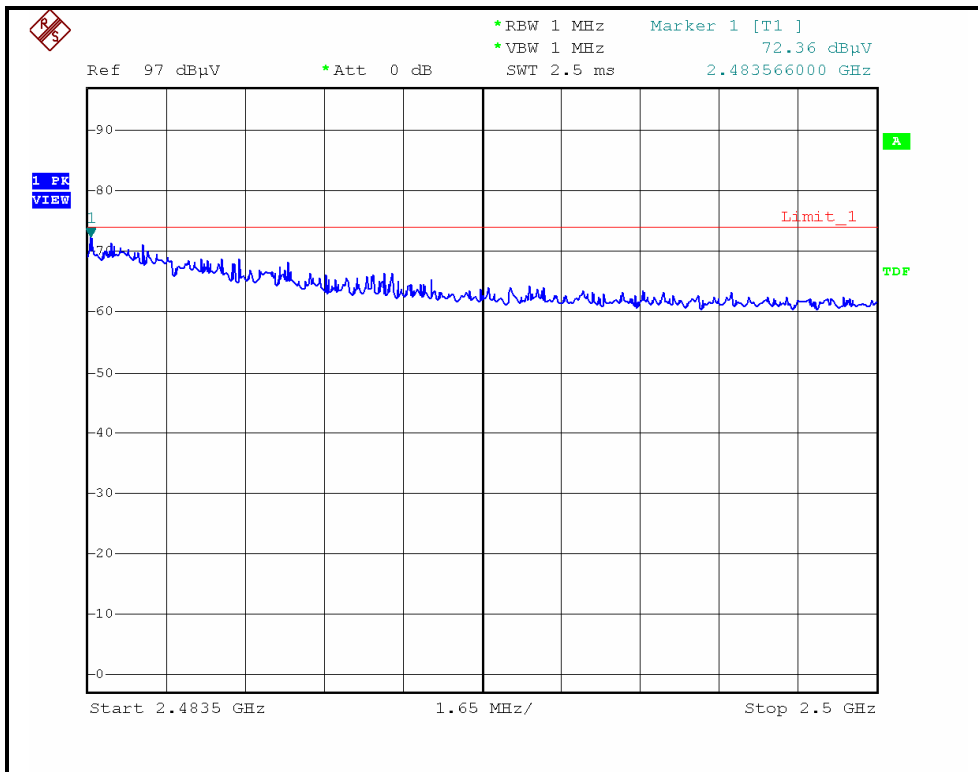



A D T

4.2.11 TEST RESULTS –ANTENNA 8

BELOW 1GHz WORST-CASE DATA : 802.11b DSSS MODULATION

EUT TEST CONDITION		MEASUREMENT DETAIL	
CHANNEL	Channel 1	FREQUENCY RANGE	Below 1000MHz
INPUT POWER	120Vac, 60 Hz	DETECTOR FUNCTION	Quasi-Peak
ENVIRONMENTAL CONDITIONS	30.0deg. C, 55.0%RH 965hPa	TESTED BY	Frank Liu

ANTENNA POLARITY & TEST DISTANCE: HORIZONTAL AT 3 M								
NO.	FREQ. (MHz)	EMISSION LEVEL (dBuV/m)	LIMIT (dBuV/m)	MARGIN (dB)	ANTENNA HEIGHT (m)	TABLE ANGLE (Degree)	RAW VALUE (dBuV)	CORRECTION FACTOR (dB/m)
1	125.00	26.41 QP	43.50	-17.09	1.52 H	149	13.34	13.07
2	250.00	35.90 QP	46.00	-10.10	1.07 H	252	21.65	14.25
3	375.00	39.97 QP	46.00	-6.03	1.00 H	303	21.16	18.81
4	650.00	44.76 QP	46.00	-1.24	1.00 H	244	19.23	25.53
5	750.00	35.22 QP	46.00	-10.78	1.00 H	235	8.31	26.91
6	875.00	37.19 QP	46.00	-8.81	1.00 H	6	7.90	29.29
7	1000.00	38.00 QP	54.00	-16.00	1.00 H	28	7.26	30.74

ANTENNA POLARITY & TEST DISTANCE: VERTICAL AT 3 M								
NO.	FREQ. (MHz)	EMISSION LEVEL (dBuV/m)	LIMIT (dBuV/m)	MARGIN (dB)	ANTENNA HEIGHT (m)	TABLE ANGLE (Degree)	RAW VALUE (dBuV)	CORRECTION FACTOR (dB/m)
1	57.21	32.92 QP	40.00	-7.08	1.00 V	289	19.23	13.69
2	125.00	29.11 QP	43.50	-14.39	1.00 V	29	16.04	13.07
3	250.00	28.85 QP	46.00	-17.15	1.00 V	19	14.60	14.25
4	375.00	39.76 QP	46.00	-6.24	1.07 V	227	20.95	18.81
5	500.00	34.43 QP	46.00	-11.57	1.00 V	207	11.94	22.49
6	600.00	37.44 QP	46.00	-8.56	1.00 V	313	12.40	25.04
7	650.00	39.57 QP	46.00	-6.43	1.00 V	206	14.04	25.53

- REMARKS:**
1. Emission level (dBuV/m) = Raw Value (dBuV) + Correction Factor (dB/m).
  2. Correction Factor (dB/m) = Antenna Factor (dB/m) + Cable Factor (dB).
  3. The other emission levels were very low against the limit.
  4. Margin value = Emission level – Limit value.





**ABOVE 1GHz WORST-CASE DATA**

**802.11b DSSS MODULATION**

EUT TEST CONDITION		MEASUREMENT DETAIL	
CHANNEL	Channel 1	FREQUENCY RANGE	1 ~ 25GHz
INPUT POWER	120Vac, 60 Hz	DETECTOR FUNCTION	Peak (PK) Average (AV)
ENVIRONMENTAL CONDITIONS	30.0deg. C, 55.0%RH 965hPa	TESTED BY	Eric Lee

**ANTENNA POLARITY & TEST DISTANCE: HORIZONTAL AT 3 M**

NO.	FREQ. (MHz)	EMISSION LEVEL (dBuV/m)	LIMIT (dBuV/m)	MARGIN (dB)	ANTENNA HEIGHT (m)	TABLE ANGLE (Degree)	RAW VALUE (dBuV)	CORRECTION FACTOR (dB/m)
1	2386.00	62.75 PK	74.00	-11.25	1.34 H	296	32.70	30.05
2	2386.00	52.96 AV	54.00	-1.04	1.34 H	296	22.91	30.05
3	*2412.00	122.27 PK			1.35 H	290	92.12	30.15
4	*2412.00	118.02 AV			1.35 H	290	87.87	30.15
5	4824.00	48.39 PK	74.00	-25.61	1.40 H	68	12.93	35.46
6	4824.00	39.66 AV	54.00	-14.34	1.40 H	68	4.20	35.46

**ANTENNA POLARITY & TEST DISTANCE: VERTICAL AT 3 M**

NO.	FREQ. (MHz)	EMISSION LEVEL (dBuV/m)	LIMIT (dBuV/m)	MARGIN (dB)	ANTENNA HEIGHT (m)	TABLE ANGLE (Degree)	RAW VALUE (dBuV)	CORRECTION FACTOR (dB/m)
1	2385.30	58.77 PK	74.00	-15.23	1.67 V	13	28.73	30.04
2	2385.30	49.95 AV	54.00	-4.05	1.67 V	13	19.91	30.04
3	*2412.00	118.60 PK			1.66 V	29	88.45	30.15
4	*2412.00	115.30 AV			1.66 V	29	85.15	30.15
5	4824.00	44.60 PK	74.00	-29.40	1.00 V	237	9.14	35.46
6	4824.00	32.40 AV	54.00	-21.60	1.00 V	237	-3.06	35.46

- REMARKS:**
1. Emission level (dBuV/m) = Raw Value (dBuV) + Correction Factor (dB/m).
  2. Correction Factor (dB/m) = Antenna Factor (dB/m) + Cable Factor (dB).
  3. The other emission levels were very low against the limit.
  4. Margin value = Emission level – Limit value.
  5. “ \* “: Fundamental frequency.



A D T

EUT TEST CONDITION		MEASUREMENT DETAIL	
CHANNEL	Channel 6	FREQUENCY RANGE	1 ~ 25GHz
INPUT POWER	120Vac, 60 Hz	DETECTOR FUNCTION	Peak (PK) Average (AV)
ENVIRONMENTAL CONDITIONS	30.0deg. C, 55.0%RH 965hPa	TESTED BY	Eric Lee

ANTENNA POLARITY & TEST DISTANCE: HORIZONTAL AT 3 M								
NO.	FREQ. (MHz)	EMISSION LEVEL (dBuV/m)	LIMIT (dBuV/m)	MARGIN (dB)	ANTENNA HEIGHT (m)	TABLE ANGLE (Degree)	RAW VALUE (dBuV)	CORRECTION FACTOR (dB/m)
1	2390.00	65.50 PK	74.00	-8.50	1.40 H	293	35.44	30.06
2	2390.00	53.11 AV	54.00	-0.89	1.40 H	293	23.05	30.06
3	*2437.00	126.33 PK			1.32 H	64	96.09	30.24
4	*2437.00	121.65 AV			1.32 H	64	91.41	30.24
5	2483.50	64.87 PK	74.00	-9.13	1.34 H	65	34.44	30.43
6	2483.50	53.12 AV	54.00	-0.88	1.34 H	65	22.69	30.43
7	4874.00	51.23 PK	74.00	-22.77	1.35 H	30	15.68	35.55
8	4874.00	41.62 AV	54.00	-12.38	1.35 H	30	6.07	35.55
9	7311.00	56.83 PK	74.00	-17.17	1.38 H	31	14.79	42.04
10	7311.00	45.96 AV	54.00	-8.04	1.38 H	31	3.92	42.04
ANTENNA POLARITY & TEST DISTANCE: VERTICAL AT 3 M								
NO.	FREQ. (MHz)	EMISSION LEVEL (dBuV/m)	LIMIT (dBuV/m)	MARGIN (dB)	ANTENNA HEIGHT (m)	TABLE ANGLE (Degree)	RAW VALUE (dBuV)	CORRECTION FACTOR (dB/m)
1	2390.00	62.20 PK	74.00	-11.80	1.64 V	72	32.14	30.06
2	2390.00	50.30 AV	54.00	-3.70	1.64 V	72	20.24	30.06
3	*2437.00	123.60 PK			1.63 V	279	93.36	30.24
4	*2437.00	118.40 AV			1.63 V	279	88.16	30.24
5	2483.50	61.20 PK	74.00	-12.80	1.62 V	69	30.77	30.43
6	2483.50	49.60 AV	54.00	-4.40	1.62 V	69	19.17	30.43
7	4874.00	45.30 PK	74.00	-28.70	1.00 V	239	9.75	35.55
8	4874.00	33.50 AV	54.00	-20.50	1.00 V	239	-2.05	35.55
9	7311.00	51.70 PK	74.00	-22.30	1.50 V	64	9.66	42.04
10	7311.00	39.20 AV	54.00	-14.80	1.50 V	64	-2.84	42.04

- REMARKS:**
1. Emission level (dBuV/m) = Raw Value (dBuV) + Correction Factor (dB/m).
  2. Correction Factor (dB/m) = Antenna Factor (dB/m) + Cable Factor (dB).
  3. The other emission levels were very low against the limit.
  4. Margin value = Emission level – Limit value.
  5. “ \* ”: Fundamental frequency.



A D T

EUT TEST CONDITION		MEASUREMENT DETAIL	
CHANNEL	Channel 11	FREQUENCY RANGE	1 ~ 25GHz
INPUT POWER	120Vac, 60 Hz	DETECTOR FUNCTION	Peak (PK) Average (AV)
ENVIRONMENTAL CONDITIONS	30.0deg. C, 55.0%RH 965hPa	TESTED BY	Eric Lee

ANTENNA POLARITY & TEST DISTANCE: HORIZONTAL AT 3 M								
NO.	FREQ. (MHz)	EMISSION LEVEL (dBuV/m)	LIMIT (dBuV/m)	MARGIN (dB)	ANTENNA HEIGHT (m)	TABLE ANGLE (Degree)	RAW VALUE (dBuV)	CORRECTION FACTOR (dB/m)
1	*2462.00	123.74 PK			1.32 H	295	93.40	30.34
2	*2462.00	119.09 AV			1.32 H	295	88.75	30.34
3	2487.00	63.53 PK	74.00	-10.47	1.32 H	298	33.09	30.44
4	2487.00	52.88 AV	54.00	-1.12	1.32 H	298	22.44	30.44
5	4924.00	50.19 PK	74.00	-23.81	1.35 H	52	14.56	35.63
6	4924.00	40.60 AV	54.00	-13.40	1.35 H	52	4.97	35.63
7	7386.00	56.66 PK	74.00	-17.34	1.35 H	29	14.43	42.23
8	7386.00	45.72 AV	54.00	-8.28	1.35 H	29	3.49	42.23
ANTENNA POLARITY & TEST DISTANCE: VERTICAL AT 3 M								
NO.	FREQ. (MHz)	EMISSION LEVEL (dBuV/m)	LIMIT (dBuV/m)	MARGIN (dB)	ANTENNA HEIGHT (m)	TABLE ANGLE (Degree)	RAW VALUE (dBuV)	CORRECTION FACTOR (dB/m)
1	*2462.00	120.30 PK			1.65 V	274	89.96	30.34
2	*2462.00	116.20 AV			1.65 V	274	85.86	30.34
3	2487.00	59.88 PK	74.00	-14.12	1.52 V	0	29.44	30.44
4	2487.00	51.36 AV	54.00	-2.64	1.52 V	0	20.92	30.44
5	4924.00	45.60 PK	74.00	-28.40	1.00 V	244	9.97	35.63
6	4924.00	33.80 AV	54.00	-20.20	1.00 V	244	-1.83	35.63
7	7386.00	52.30 PK	74.00	-21.70	1.54 V	69	10.07	42.23
8	7386.00	39.60 AV	54.00	-14.40	1.54 V	69	-2.63	42.23

- REMARKS:**
1. Emission level (dBuV/m) = Raw Value (dBuV) + Correction Factor (dB/m).
  2. Correction Factor (dB/m) = Antenna Factor (dB/m) + Cable Factor (dB).
  3. The other emission levels were very low against the limit.
  4. Margin value = Emission level – Limit value.
  5. “ \* “: Fundamental frequency.



A D T

### RESTRICTED BANDEDGE (802.11b MODE,CH1, HORIZONTAL )

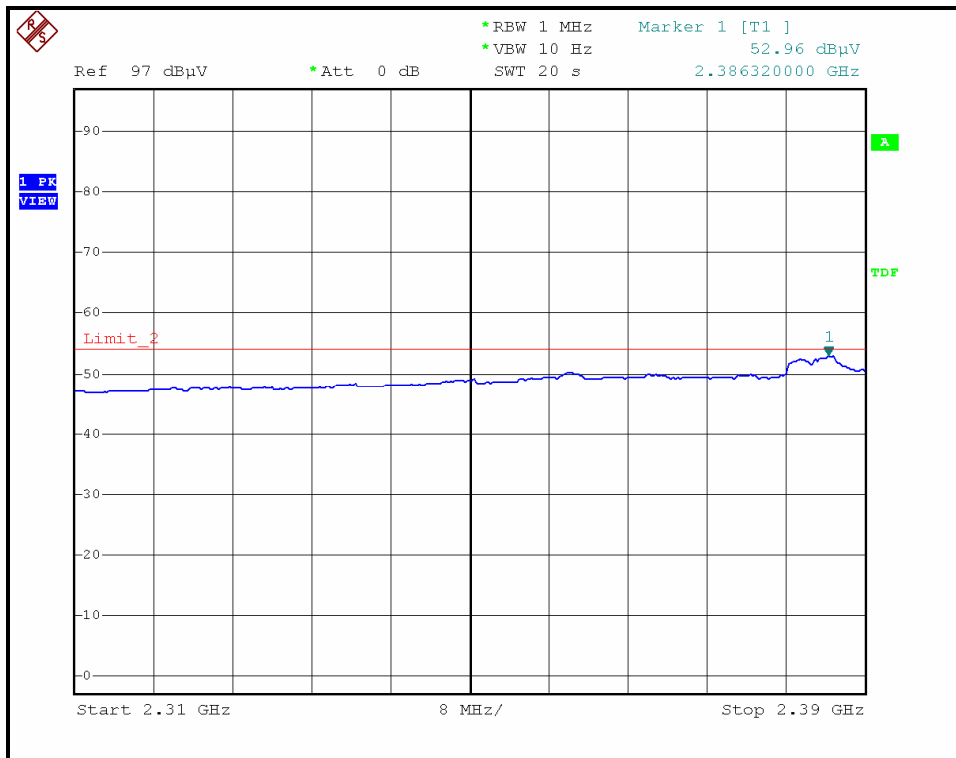
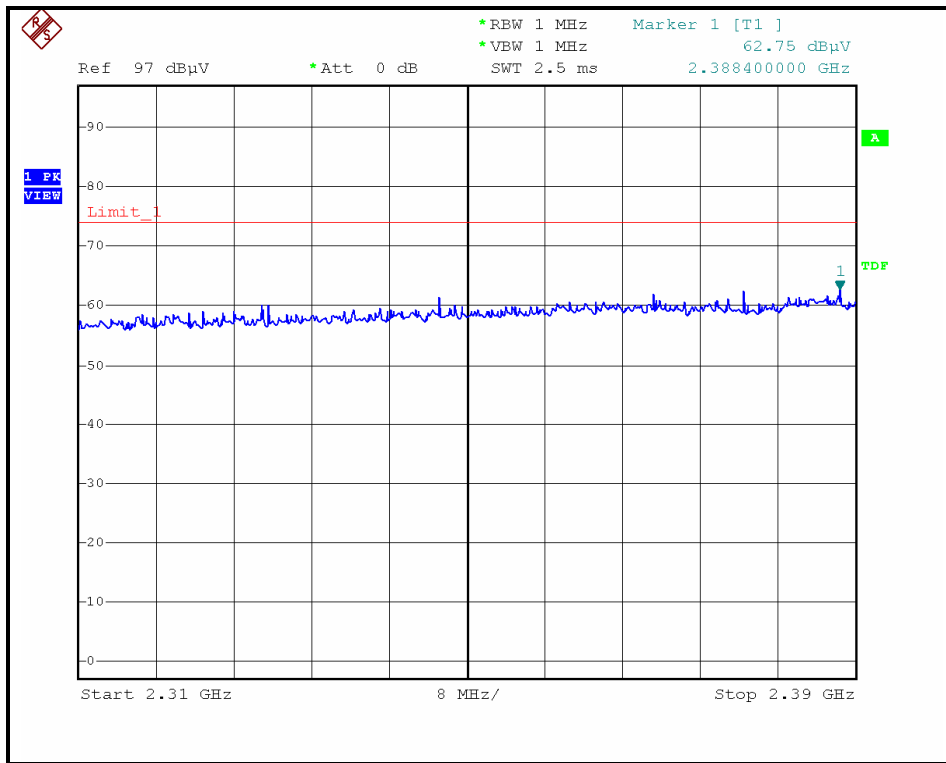



A D T

### RESTRICTED BANDEDGE (802.11b MODE,CH1, VERTICAL )

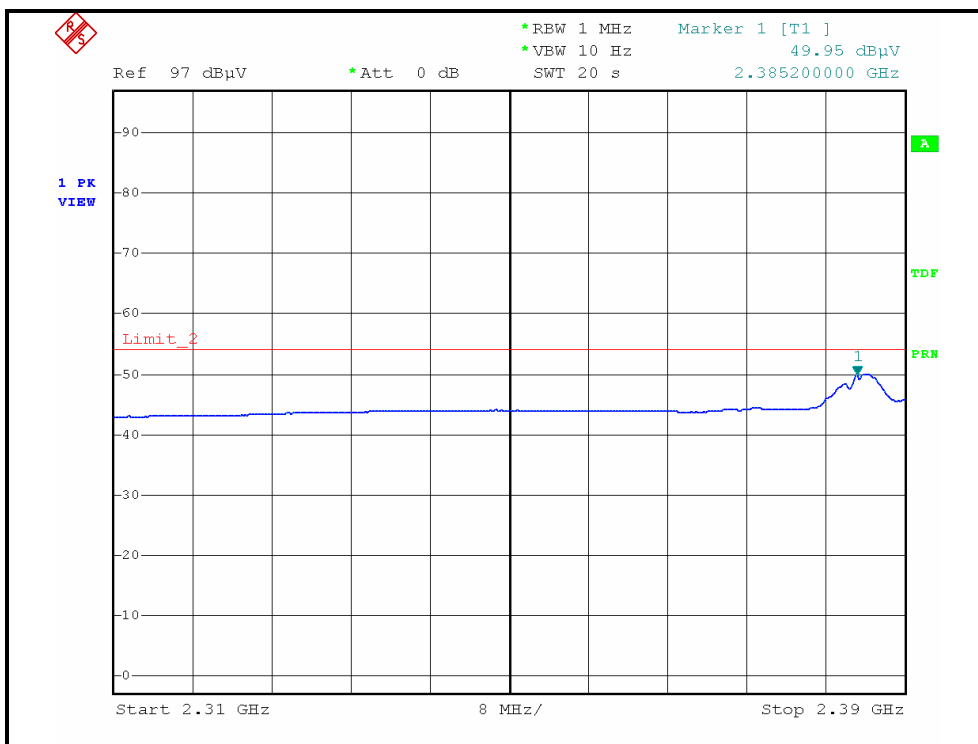
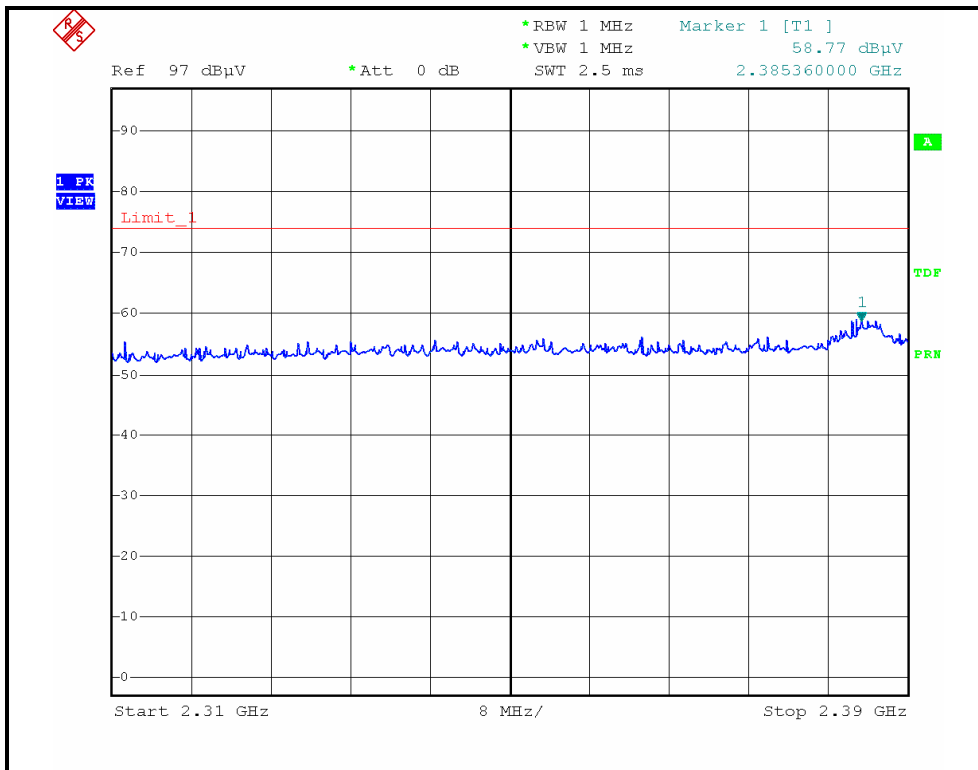



A D T

### RESTRICTED BANDEDGE (802.11b MODE,CH11, HORIZONTAL )

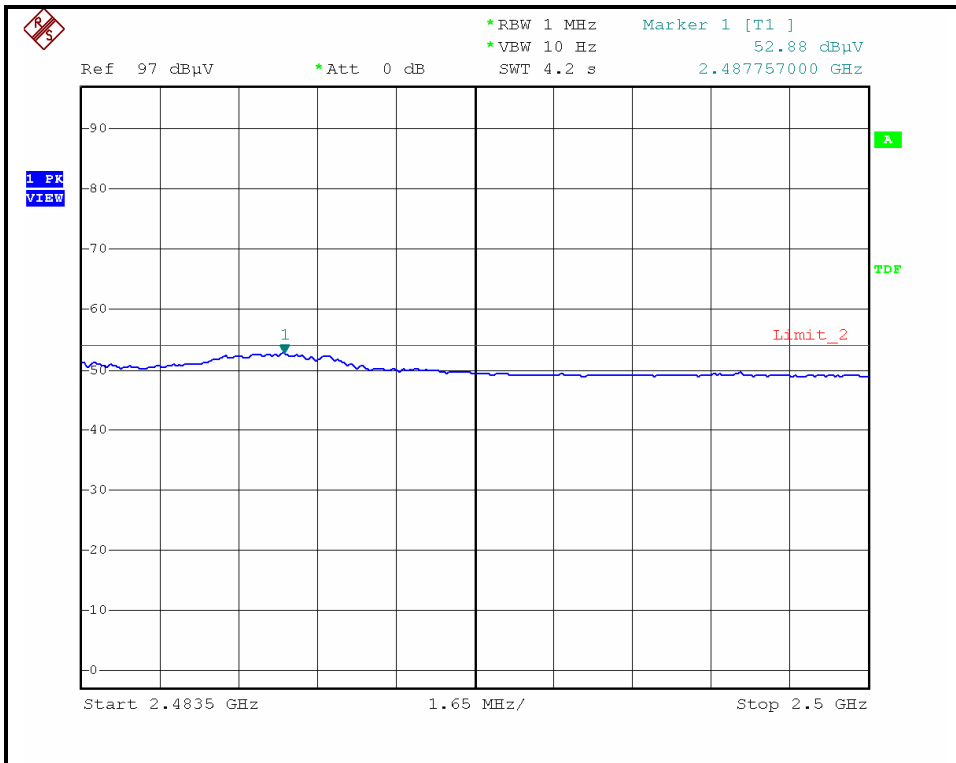
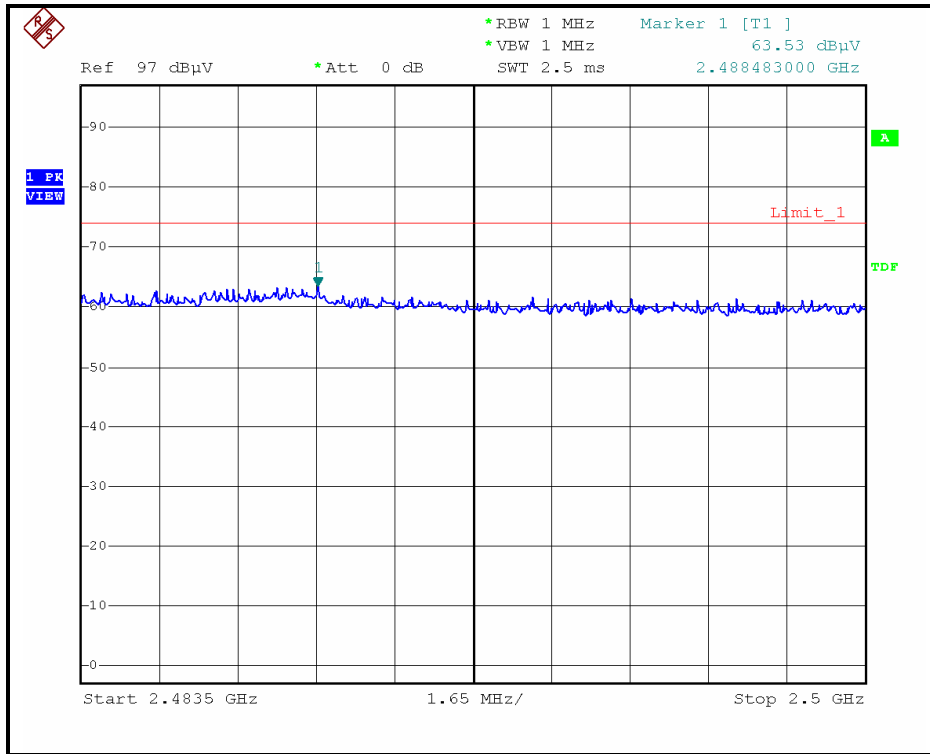



A D T

### RESTRICTED BANDEDGE (802.11b MODE, CH11, VERTICAL )

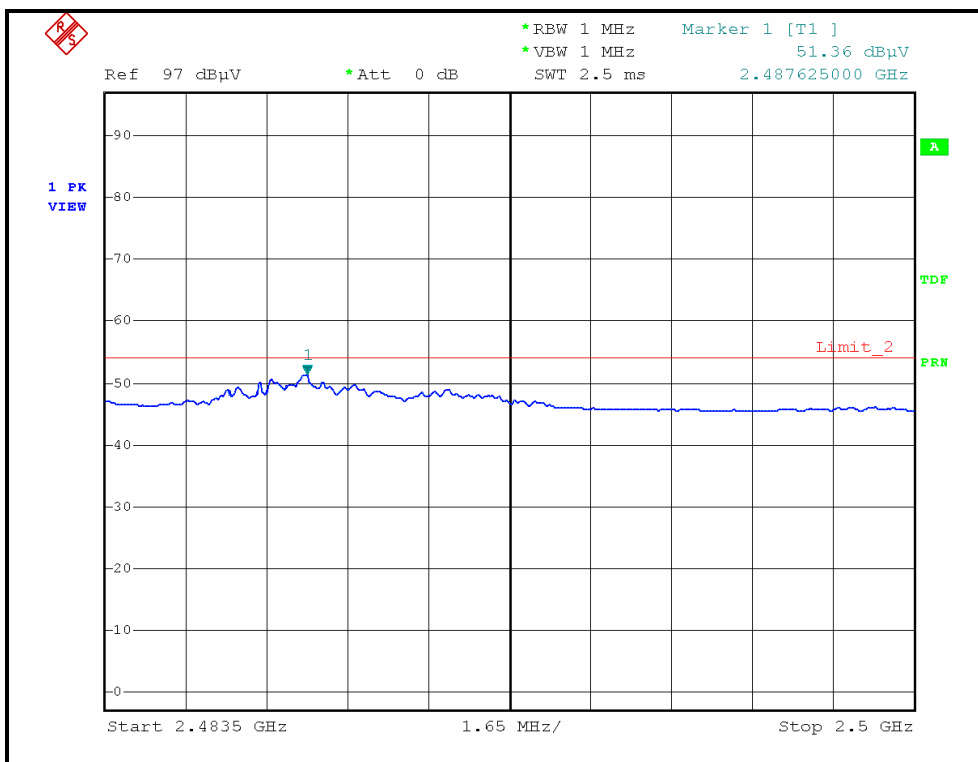
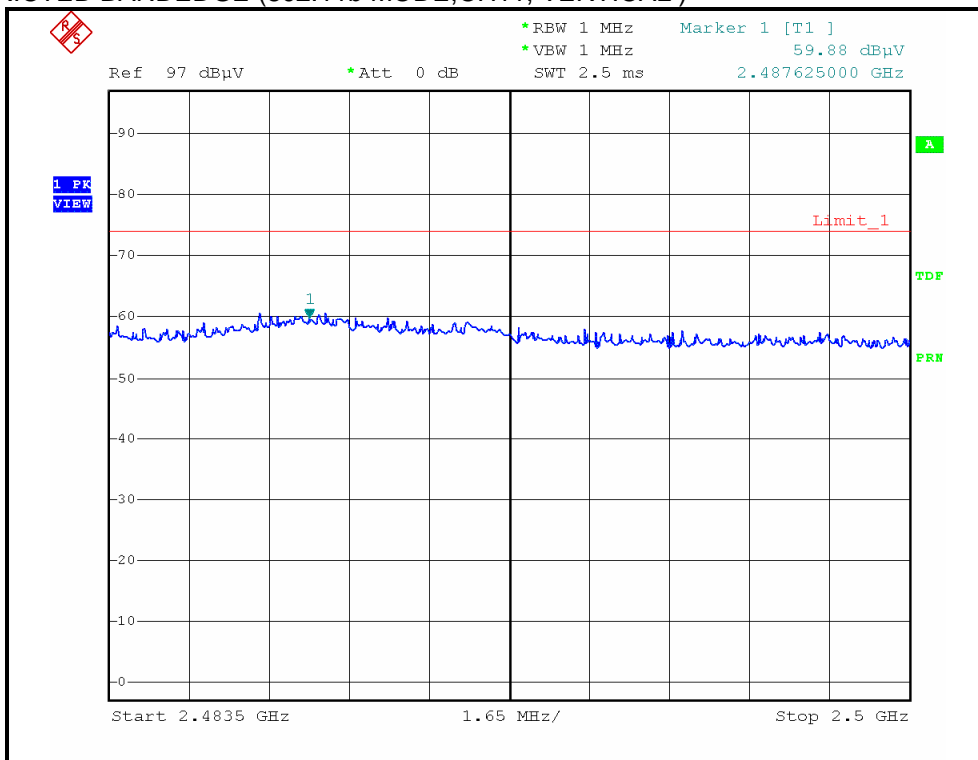



A D T

## 802.11g OFDM MODULATION

EUT TEST CONDITION		MEASUREMENT DETAIL	
CHANNEL	Channel 1	FREQUENCY RANGE	1 ~ 25GHz
INPUT POWER	120Vac, 60 Hz	DETECTOR FUNCTION	Peak (PK) Average (AV)
ENVIRONMENTAL CONDITIONS	30.0deg. C, 55.0%RH 965hPa	TESTED BY	Eric Lee

ANTENNA POLARITY & TEST DISTANCE: HORIZONTAL AT 3 M								
NO.	FREQ. (MHz)	EMISSION LEVEL (dBuV/m)	LIMIT (dBuV/m)	MARGIN (dB)	ANTENNA HEIGHT (m)	TABLE ANGLE (Degree)	RAW VALUE (dBuV)	CORRECTION FACTOR (dB/m)
1	2390.00	67.78 PK	74.00	-6.22	1.35 H	289	37.72	30.06
2	2390.00	53.30 AV	54.00	-0.70	1.35 H	289	23.24	30.06
3	*2412.00	121.39 PK			1.35 H	68	91.24	30.15
4	*2412.00	111.00 AV			1.35 H	68	80.85	30.15
5	4824.00	47.35 PK	74.00	-26.65	1.36 H	59	11.89	35.46
6	4824.00	33.83 AV	54.00	-20.17	1.36 H	59	-1.63	35.46
ANTENNA POLARITY & TEST DISTANCE: VERTICAL AT 3 M								
NO.	FREQ. (MHz)	EMISSION LEVEL (dBuV/m)	LIMIT (dBuV/m)	MARGIN (dB)	ANTENNA HEIGHT (m)	TABLE ANGLE (Degree)	RAW VALUE (dBuV)	CORRECTION FACTOR (dB/m)
1	2390.00	65.40 PK	74.00	-8.60	1.34 V	327	35.34	30.06
2	2390.00	50.81 AV	54.00	-3.19	1.34 V	327	20.75	30.06
3	*2412.00	118.20 PK			1.37 V	351	88.05	30.15
4	*2412.00	108.40 AV			1.37 V	351	78.25	30.15
5	4824.00	46.70 PK	74.00	-27.30	1.00 V	253	11.24	35.46
6	4824.00	32.60 AV	54.00	-21.40	1.00 V	253	-2.86	35.46

- REMARKS:**
1. Emission level (dBuV/m) = Raw Value (dBuV) + Correction Factor (dB/m).
  2. Correction Factor (dB/m) = Antenna Factor (dB/m) + Cable Factor (dB).
  3. The other emission levels were very low against the limit.
  4. Margin value = Emission level – Limit value.
  5. “ \* “: Fundamental frequency.





A D T

EUT TEST CONDITION		MEASUREMENT DETAIL	
CHANNEL	Channel 6	FREQUENCY RANGE	1 ~ 25GHz
INPUT POWER	120Vac, 60 Hz	DETECTOR FUNCTION	Peak (PK) Average (AV)
ENVIRONMENTAL CONDITIONS	30.0deg. C, 55.0%RH 965hPa	TESTED BY	Eric Lee

ANTENNA POLARITY & TEST DISTANCE: HORIZONTAL AT 3 M								
NO.	FREQ. (MHz)	EMISSION LEVEL (dBuV/m)	LIMIT (dBuV/m)	MARGIN (dB)	ANTENNA HEIGHT (m)	TABLE ANGLE (Degree)	RAW VALUE (dBuV)	CORRECTION FACTOR (dB/m)
1	2390.00	65.26 PK	74.00	-8.74	1.35 H	67	35.20	30.06
2	2390.00	53.06 AV	54.00	-0.94	1.35 H	67	23.00	30.06
3	*2437.00	122.40 PK			1.34 H	63	92.16	30.24
4	*2437.00	112.62 AV			1.34 H	63	82.38	30.24
5	2483.50	65.91 PK	74.00	-8.09	1.36 H	288	35.49	30.43
6	2483.50	52.92 AV	54.00	-1.08	1.36 H	288	22.49	30.43
7	4874.00	47.51 PK	74.00	-26.49	1.31 H	55	11.96	35.55
8	4874.00	33.88 AV	54.00	-20.12	1.31 H	55	-1.67	35.55
9	7311.00	53.44 PK	74.00	-20.56	1.39 H	28	11.40	42.04
10	7311.00	39.63 AV	54.00	-14.37	1.39 H	28	-2.41	42.04

ANTENNA POLARITY & TEST DISTANCE: VERTICAL AT 3 M								
NO.	FREQ. (MHz)	EMISSION LEVEL (dBuV/m)	LIMIT (dBuV/m)	MARGIN (dB)	ANTENNA HEIGHT (m)	TABLE ANGLE (Degree)	RAW VALUE (dBuV)	CORRECTION FACTOR (dB/m)
1	2390.00	61.40 PK	74.00	-12.60	1.34 V	341	31.34	30.06
2	2390.00	50.30 AV	54.00	-3.70	1.34 V	341	20.24	30.06
3	*2437.00	119.30 PK			1.36 V	324	89.06	30.24
4	*2437.00	108.70 AV			1.36 V	324	78.46	30.24
5	4874.00	48.60 PK	74.00	-25.40	1.00 V	248	13.05	35.55
6	4874.00	34.20 AV	54.00	-19.80	1.00 V	248	-1.35	35.55
7	7311.00	53.10 PK	74.00	-20.90	1.54 V	29	11.06	42.04
8	7311.00	38.40 AV	54.00	-15.60	1.54 V	29	-3.64	42.04

- REMARKS:**
1. Emission level (dBuV/m) = Raw Value (dBuV) + Correction Factor (dB/m).
  2. Correction Factor (dB/m) = Antenna Factor (dB/m) + Cable Factor (dB).
  3. The other emission levels were very low against the limit.
  4. Margin value = Emission level – Limit value.
  5. “ \* “: Fundamental frequency.



A D T

EUT TEST CONDITION		MEASUREMENT DETAIL	
CHANNEL	Channel 11	FREQUENCY RANGE	1 ~ 25GHz
INPUT POWER	120Vac, 60 Hz	DETECTOR FUNCTION	Peak (PK) Average (AV)
ENVIRONMENTAL CONDITIONS	30.0deg. C, 55.0%RH 965hPa	TESTED BY	Eric Lee

**ANTENNA POLARITY & TEST DISTANCE: HORIZONTAL AT 3 M**

NO.	FREQ. (MHz)	EMISSION LEVEL (dBuV/m)	LIMIT (dBuV/m)	MARGIN (dB)	ANTENNA HEIGHT (m)	TABLE ANGLE (Degree)	RAW VALUE (dBuV)	CORRECTION FACTOR (dB/m)
1	*2462.00	120.88 PK			1.36 H	66	90.54	30.34
2	*2462.00	109.91 AV			1.36 H	66	79.57	30.34
3	2483.50	69.60 PK	74.00	-4.40	1.35 H	67	39.17	30.43
4	2483.50	53.16 AV	54.00	-0.84	1.35 H	67	22.73	30.43
5	4924.00	47.62 PK	74.00	-26.38	1.30 H	57	11.99	35.63
6	4924.00	33.73 AV	54.00	-20.27	1.30 H	57	-1.90	35.63
7	7386.00	53.48 PK	74.00	-20.52	1.38 H	50	11.25	42.23
8	7386.00	39.65 AV	54.00	-14.35	1.38 H	50	-2.58	42.23

**ANTENNA POLARITY & TEST DISTANCE: VERTICAL AT 3 M**

NO.	FREQ. (MHz)	EMISSION LEVEL (dBuV/m)	LIMIT (dBuV/m)	MARGIN (dB)	ANTENNA HEIGHT (m)	TABLE ANGLE (Degree)	RAW VALUE (dBuV)	CORRECTION FACTOR (dB/m)
1	*2462.00	117.10 PK			1.32 V	10	86.76	30.34
2	*2462.00	105.50 AV			1.32 V	10	75.16	30.34
3	2483.50	63.24 PK	74.00	-10.76	1.32 V	319	32.81	30.43
4	2483.50	51.19 AV	54.00	-2.81	1.32 V	319	20.76	30.43
5	4924.00	48.90 PK	74.00	-25.10	1.00 V	262	13.27	35.63
6	4924.00	34.60 AV	54.00	-19.40	1.00 V	262	-1.03	35.63
7	7386.00	53.20 PK	74.00	-20.80	1.57 V	36	10.97	42.23
8	7386.00	38.40 AV	54.00	-15.60	1.57 V	36	-3.83	42.23

- REMARKS:**
1. Emission level (dBuV/m) = Raw Value (dBuV) + Correction Factor (dB/m).
  2. Correction Factor (dB/m) = Antenna Factor (dB/m) + Cable Factor (dB).
  3. The other emission levels were very low against the limit.
  4. Margin value = Emission level – Limit value.
  5. “ \* “: Fundamental frequency.



A D T

### RESTRICTED BANDEDGE (802.11g MODE,CH1, HORIZONTAL )

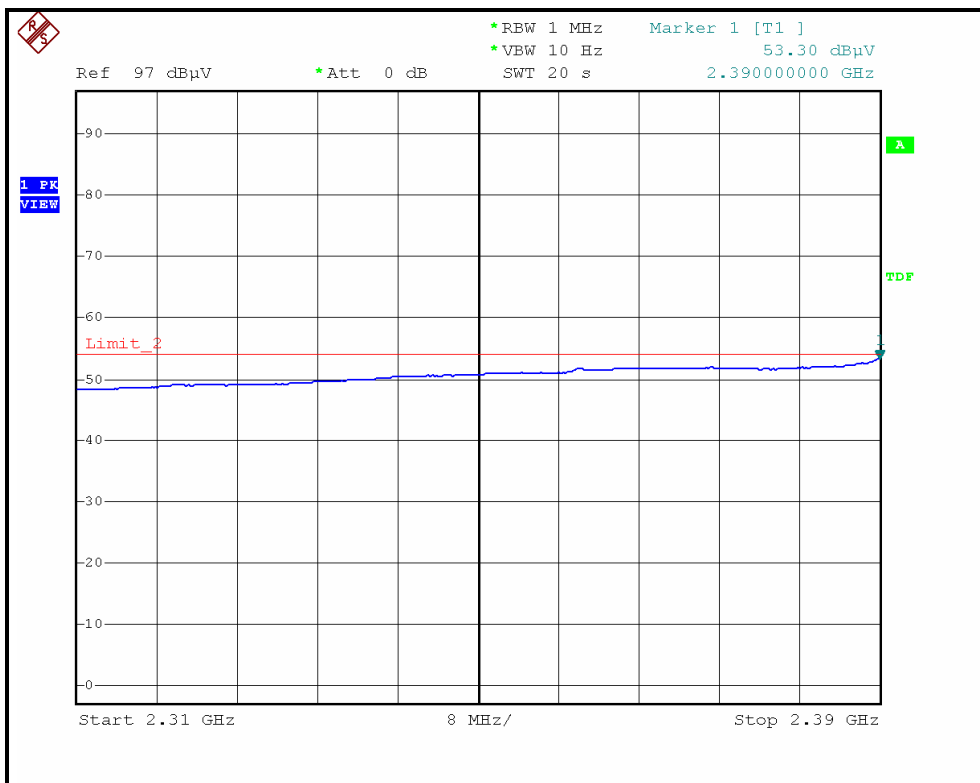
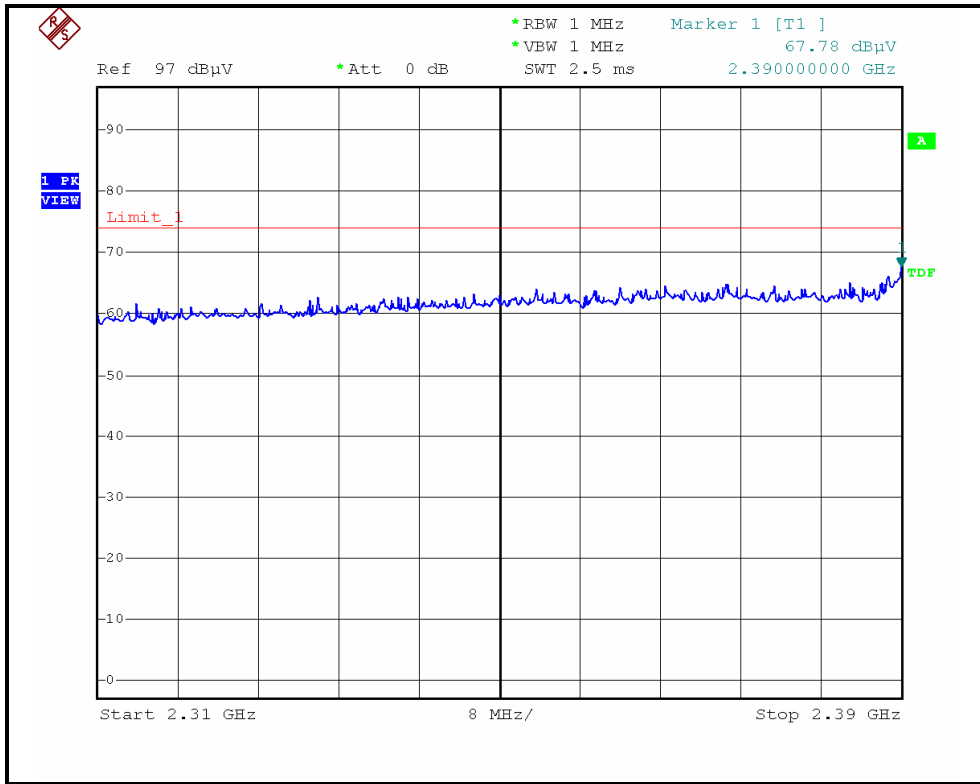



A D T

### RESTRICTED BANDEDGE (802.11g MODE,CH1, VERTICAL )

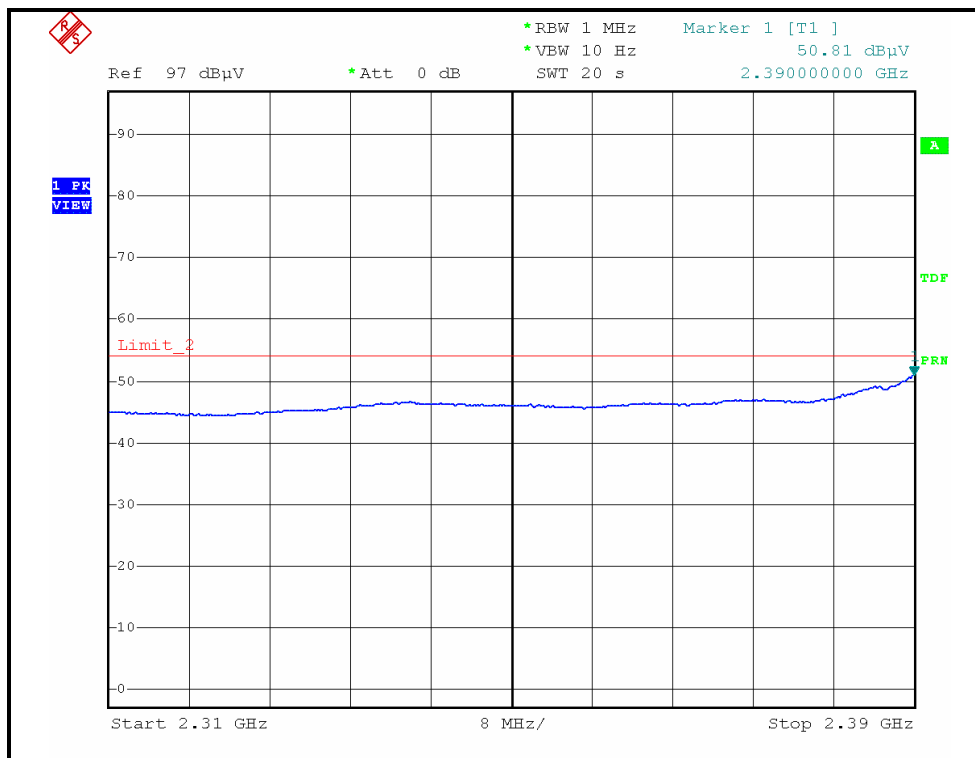
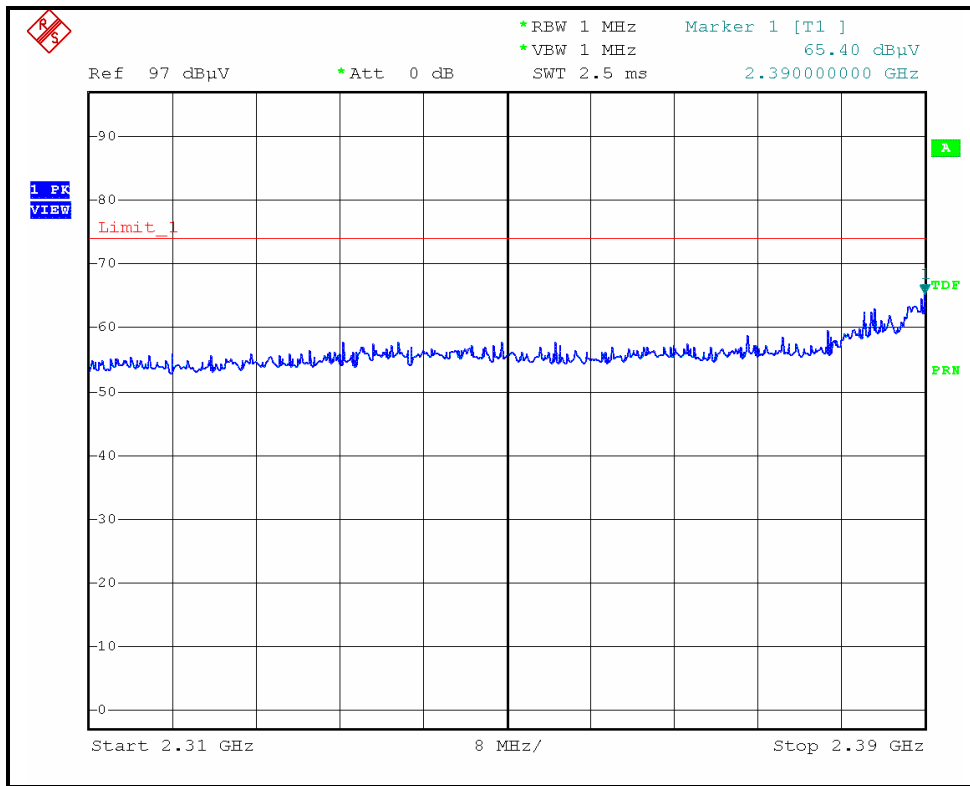



A D T

### RESTRICTED BANDEDGE (802.11g MODE,CH11, HORIZONTAL )

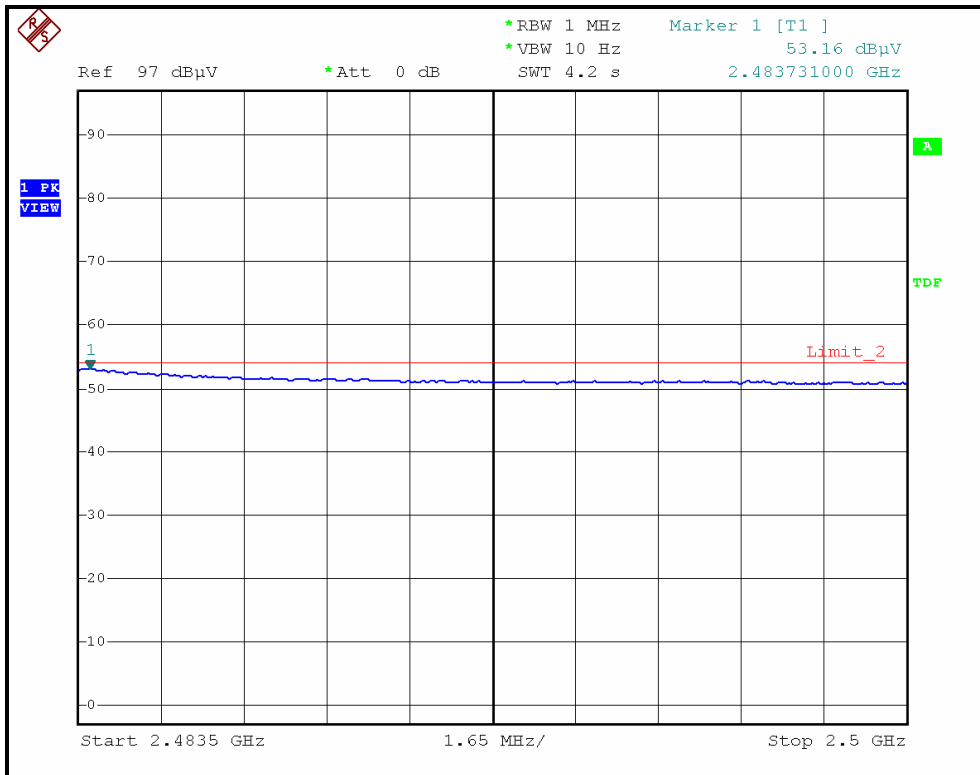
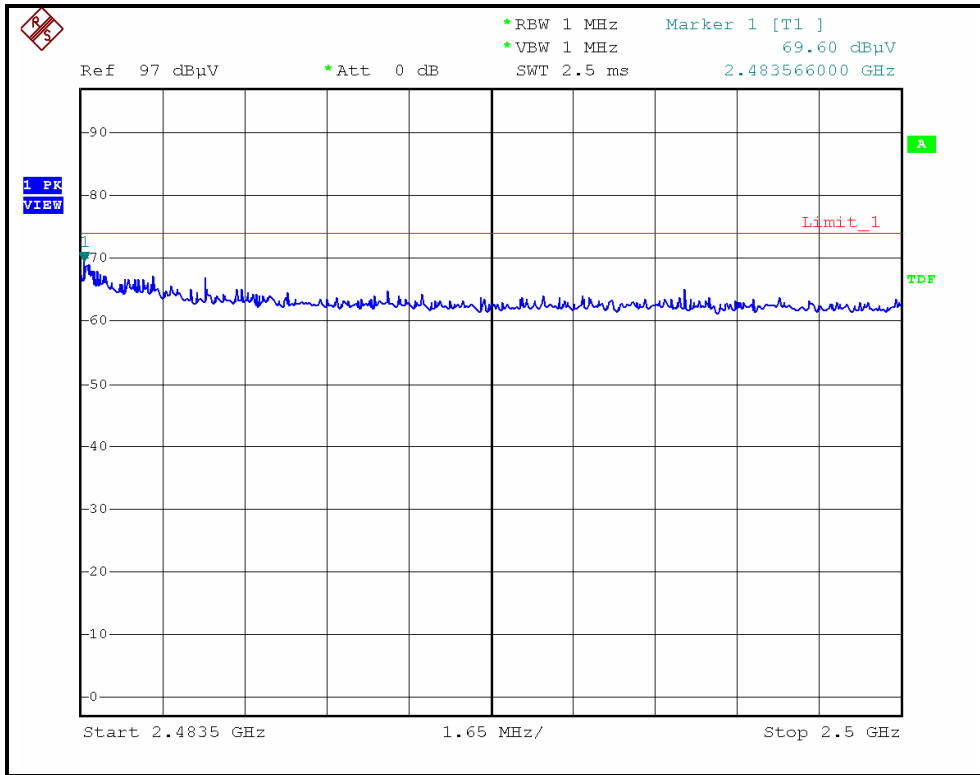



A D T

### RESTRICTED BANDEDGE (802.11g MODE,CH11, VERTICAL )

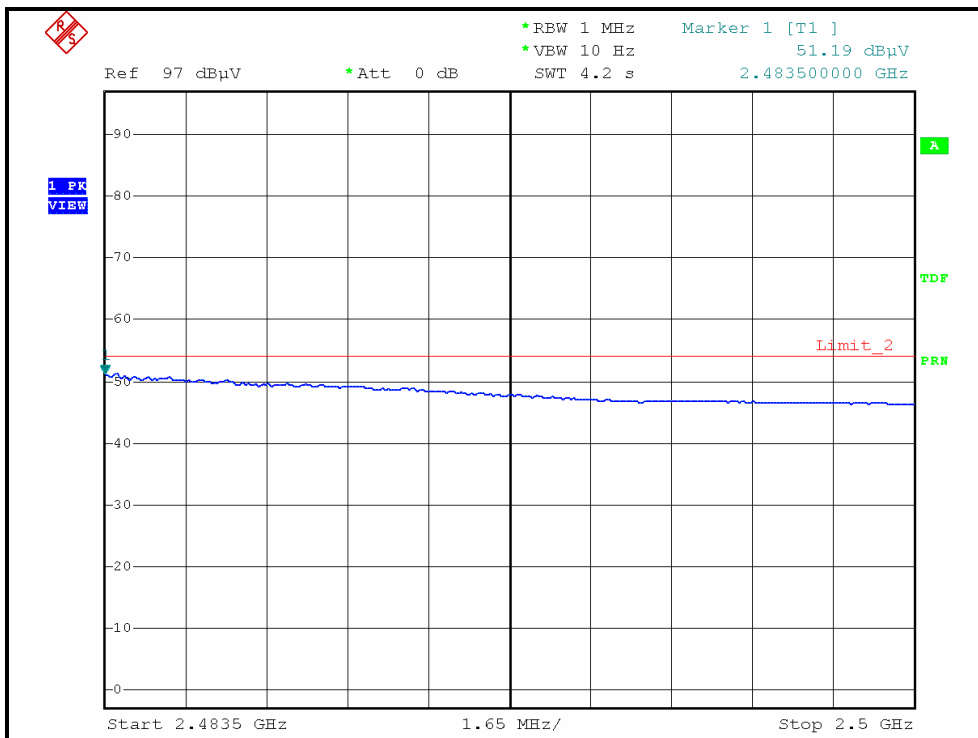
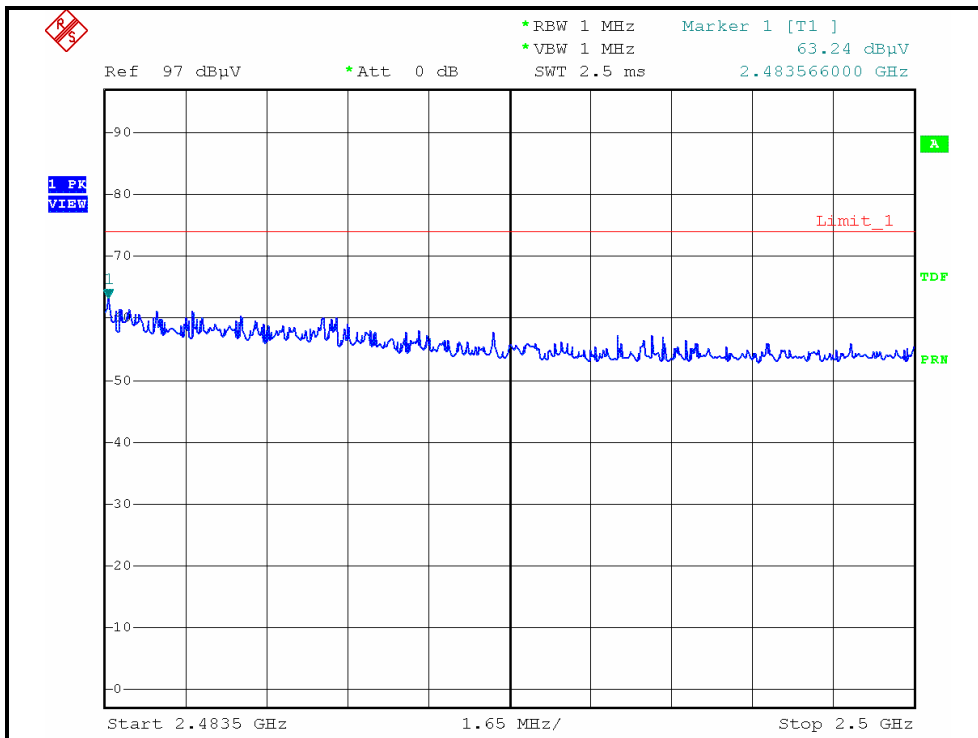



A D T

**DRAFT 802.11n (20MHz) OFDM MODULATION**

EUT TEST CONDITION		MEASUREMENT DETAIL	
CHANNEL	Channel 1	FREQUENCY RANGE	1 ~ 25GHz
INPUT POWER	120Vac, 60 Hz	DETECTOR FUNCTION	Peak (PK) Average (AV)
ENVIRONMENTAL CONDITIONS	30.0deg. C, 55.0%RH 965hPa	TESTED BY	Eric Lee

ANTENNA POLARITY & TEST DISTANCE: HORIZONTAL AT 3 M								
NO.	FREQ. (MHz)	EMISSION LEVEL (dBuV/m)	LIMIT (dBuV/m)	MARGIN (dB)	ANTENNA HEIGHT (m)	TABLE ANGLE (Degree)	RAW VALUE (dBuV)	CORRECTION FACTOR (dB/m)
1	2390.00	71.51 PK	74.00	-2.49	1.32 H	68	41.45	30.06
2	2390.00	52.64 AV	54.00	-1.36	1.32 H	68	22.58	30.06
3	*2412.00	119.74 PK			1.35 H	69	89.59	30.15
4	*2412.00	109.72 AV			1.35 H	69	79.57	30.15
5	4824.00	47.55 PK	74.00	-26.45	1.33 H	59	12.09	35.46
6	4824.00	33.74 AV	54.00	-20.26	1.33 H	59	-1.72	35.46
ANTENNA POLARITY & TEST DISTANCE: VERTICAL AT 3 M								
NO.	FREQ. (MHz)	EMISSION LEVEL (dBuV/m)	LIMIT (dBuV/m)	MARGIN (dB)	ANTENNA HEIGHT (m)	TABLE ANGLE (Degree)	RAW VALUE (dBuV)	CORRECTION FACTOR (dB/m)
1	2390.00	65.07 PK	74.00	-8.93	1.30 V	353	35.01	30.06
2	2390.00	48.06 AV	54.00	-5.94	1.30 V	353	18.00	30.06
3	*2412.00	116.20 PK			1.34 V	303	86.05	30.15
4	*2412.00	106.80 AV			1.34 V	303	76.65	30.15
5	4824.00	47.63 PK	74.00	-26.37	1.00 V	127	12.17	35.46
6	4824.00	34.10 AV	54.00	-19.90	1.00 V	127	-1.36	35.46

- REMARKS:**
1. Emission level (dBuV/m) = Raw Value (dBuV) + Correction Factor (dB/m).
  2. Correction Factor (dB/m) = Antenna Factor (dB/m) + Cable Factor (dB).
  3. The other emission levels were very low against the limit.
  4. Margin value = Emission level – Limit value.
  5. “ \* “: Fundamental frequency.



A D T

EUT TEST CONDITION		MEASUREMENT DETAIL	
CHANNEL	Channel 6	FREQUENCY RANGE	1 ~ 25GHz
INPUT POWER	120Vac, 60 Hz	DETECTOR FUNCTION	Peak (PK) Average (AV)
ENVIRONMENTAL CONDITIONS	30.0deg. C, 55.0%RH 965hPa	TESTED BY	Eric Lee

**ANTENNA POLARITY & TEST DISTANCE: HORIZONTAL AT 3 M**

NO.	FREQ. (MHz)	EMISSION LEVEL (dBuV/m)	LIMIT (dBuV/m)	MARGIN (dB)	ANTENNA HEIGHT (m)	TABLE ANGLE (Degree)	RAW VALUE (dBuV)	CORRECTION FACTOR (dB/m)
1	2390.00	66.63 PK	74.00	-7.37	1.34 H	68	36.57	30.06
2	2390.00	53.45 AV	54.00	-0.55	1.34 H	68	23.39	30.06
3	*2437.00	122.74 PK			1.31 H	66	92.50	30.24
4	*2437.00	112.10 AV			1.31 H	66	81.86	30.24
5	2483.50	65.58 PK	74.00	-8.42	1.35 H	67	35.15	30.43
6	2483.50	53.39 AV	54.00	-0.61	1.35 H	67	22.96	30.43
7	4874.00	47.68 PK	74.00	-26.32	1.30 H	47	12.13	35.55
8	4874.00	33.91 AV	54.00	-20.09	1.30 H	47	-1.64	35.55
9	7311.00	53.62 PK	74.00	-20.38	1.35 H	67	11.58	42.04
10	7311.00	39.77 AV	54.00	-14.23	1.35 H	67	-2.27	42.04

**ANTENNA POLARITY & TEST DISTANCE: VERTICAL AT 3 M**

NO.	FREQ. (MHz)	EMISSION LEVEL (dBuV/m)	LIMIT (dBuV/m)	MARGIN (dB)	ANTENNA HEIGHT (m)	TABLE ANGLE (Degree)	RAW VALUE (dBuV)	CORRECTION FACTOR (dB/m)
1	2390.00	62.73 PK	74.00	-11.27	1.36 V	329	32.67	30.06
2	2390.00	50.12 AV	54.00	-3.88	1.36 V	329	20.06	30.06
3	*2437.00	119.60 PK			1.31 V	3	89.36	30.24
4	*2437.00	109.80 AV			1.31 V	3	79.56	30.24
5	4874.00	48.20 PK	74.00	-25.80	1.00 V	156	12.65	35.55
6	4874.00	36.60 AV	54.00	-17.40	1.00 V	156	1.05	35.55
7	7311.00	53.90 PK	74.00	-20.10	1.52 V	32	11.86	42.04
8	7311.00	40.30 AV	54.00	-13.70	1.52 V	32	-1.74	42.04

- REMARKS:**
1. Emission level (dBuV/m) = Raw Value (dBuV) + Correction Factor (dB/m).
  2. Correction Factor (dB/m) = Antenna Factor (dB/m) + Cable Factor (dB).
  3. The other emission levels were very low against the limit.
  4. Margin value = Emission level – Limit value.
  5. “ \* “: Fundamental frequency.





A D T

EUT TEST CONDITION		MEASUREMENT DETAIL	
CHANNEL	Channel 11	FREQUENCY RANGE	1 ~ 25GHz
INPUT POWER	120Vac, 60 Hz	DETECTOR FUNCTION	Peak (PK) Average (AV)
ENVIRONMENTAL CONDITIONS	30.0deg. C, 55.0%RH 965hPa	TESTED BY	Eric Lee

**ANTENNA POLARITY & TEST DISTANCE: HORIZONTAL AT 3 M**

NO.	FREQ. (MHz)	EMISSION LEVEL (dBuV/m)	LIMIT (dBuV/m)	MARGIN (dB)	ANTENNA HEIGHT (m)	TABLE ANGLE (Degree)	RAW VALUE (dBuV)	CORRECTION FACTOR (dB/m)
1	*2462.00	120.03 PK			1.34 H	68	89.69	30.34
2	*2462.00	109.42 AV			1.34 H	68	79.08	30.34
3	2483.50	73.04 PK	74.00	-0.96	1.35 H	68	42.61	30.43
4	2483.50	53.36 AV	54.00	-0.64	1.35 H	68	22.93	30.43
5	4924.00	49.78 PK	74.00	-24.22	1.30 H	51	14.15	35.63
6	4924.00	33.62 AV	54.00	-20.38	1.30 H	51	-2.01	35.63
7	7386.00	53.78 PK	74.00	-20.22	1.38 H	66	11.55	42.23
8	7386.00	39.92 AV	54.00	-14.08	1.38 H	66	-2.31	42.23

**ANTENNA POLARITY & TEST DISTANCE: VERTICAL AT 3 M**

NO.	FREQ. (MHz)	EMISSION LEVEL (dBuV/m)	LIMIT (dBuV/m)	MARGIN (dB)	ANTENNA HEIGHT (m)	TABLE ANGLE (Degree)	RAW VALUE (dBuV)	CORRECTION FACTOR (dB/m)
1	*2462.00	117.60 PK			1.27 V	302	87.26	30.34
2	*2462.00	107.10 AV			1.27 V	302	76.76	30.34
3	2483.60	65.60 PK	74.00	-8.40	1.34 V	317	35.17	30.43
4	2483.60	50.28 AV	54.00	-3.72	1.34 V	317	19.85	30.43
5	4924.00	48.60 PK	74.00	-25.40	1.00 V	154	12.97	35.63
6	4924.00	34.90 AV	54.00	-19.10	1.00 V	154	-0.73	35.63
7	7386.00	54.10 PK	74.00	-19.90	1.57 V	46	11.87	42.23
8	7386.00	40.40 AV	54.00	-13.60	1.57 V	46	-1.83	42.23

- REMARKS:**
1. Emission level (dBuV/m) = Raw Value (dBuV) + Correction Factor (dB/m).
  2. Correction Factor (dB/m) = Antenna Factor (dB/m) + Cable Factor (dB).
  3. The other emission levels were very low against the limit.
  4. Margin value = Emission level – Limit value.
  5. “ \* “: Fundamental frequency.



A D T

### RESTRICTED BANDEDGE (DRAFT 802.11n (20MHz) MODE,CH1, HORIZONTAL )

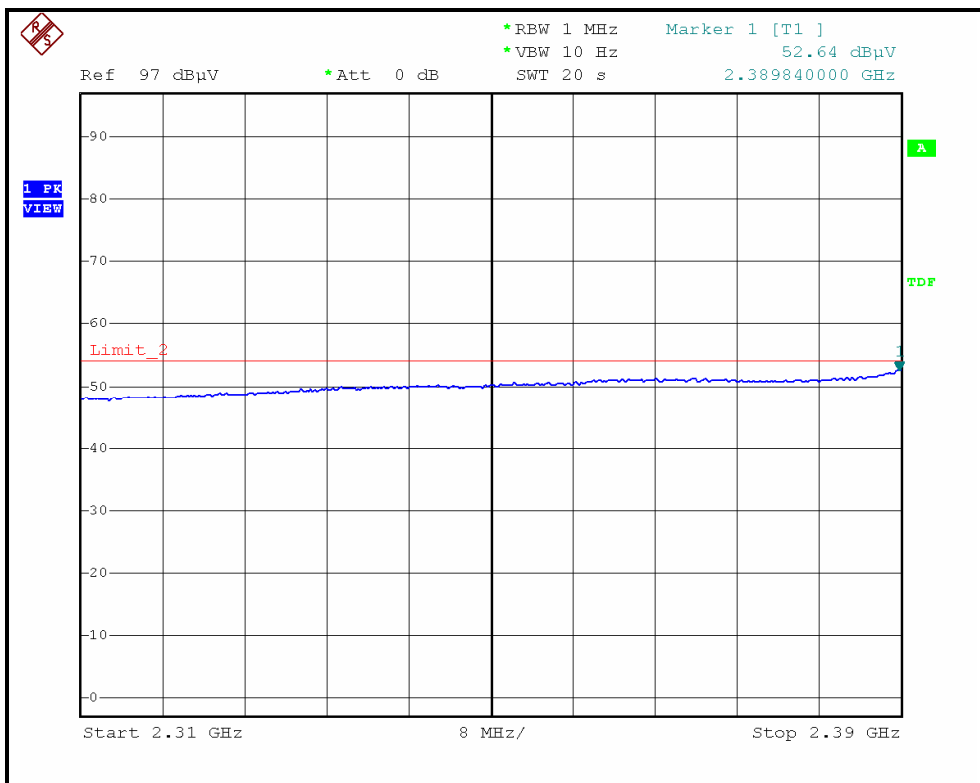
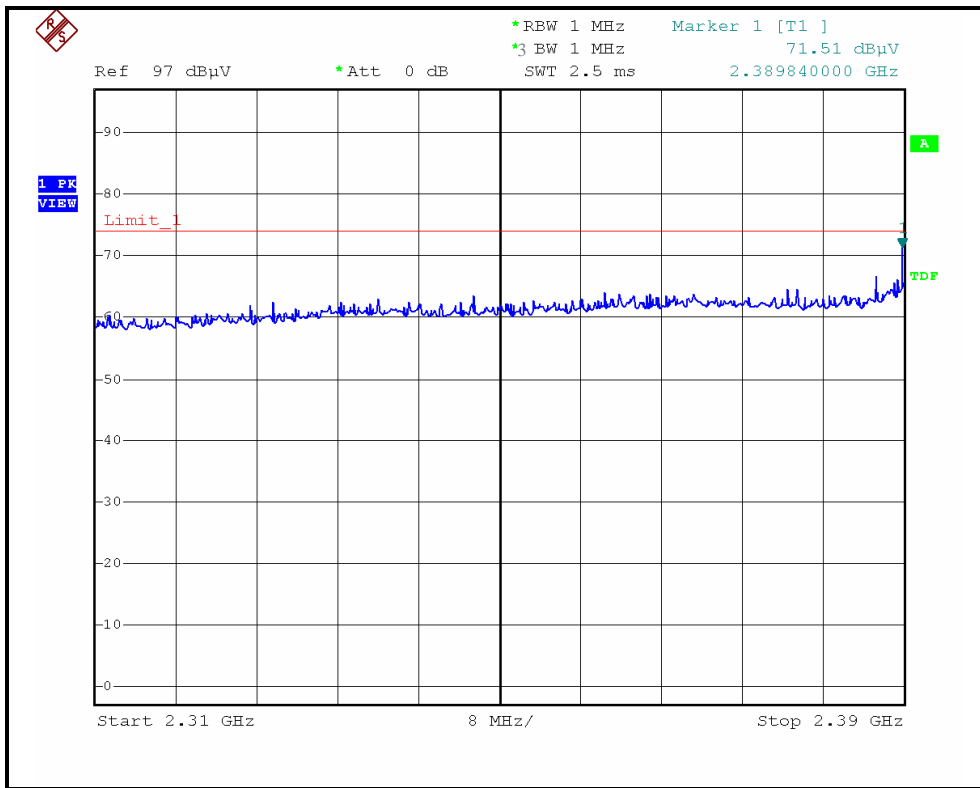



A D T

### RESTRICTED BANDEDGE (DRAFT 802.11n (20MHz) MODE,CH1, VERTICAL )

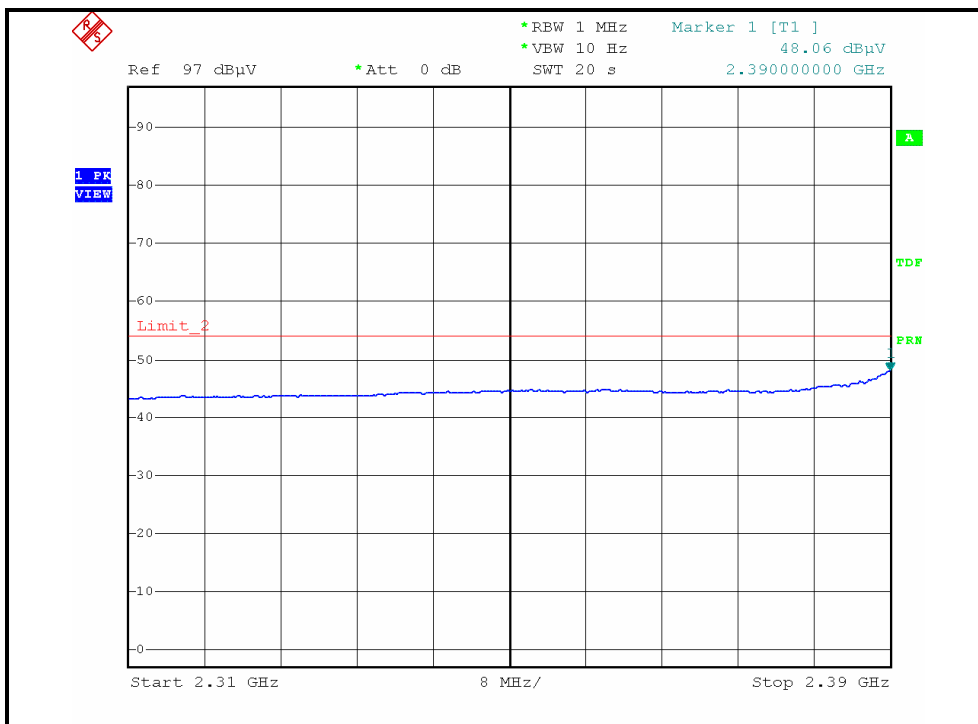
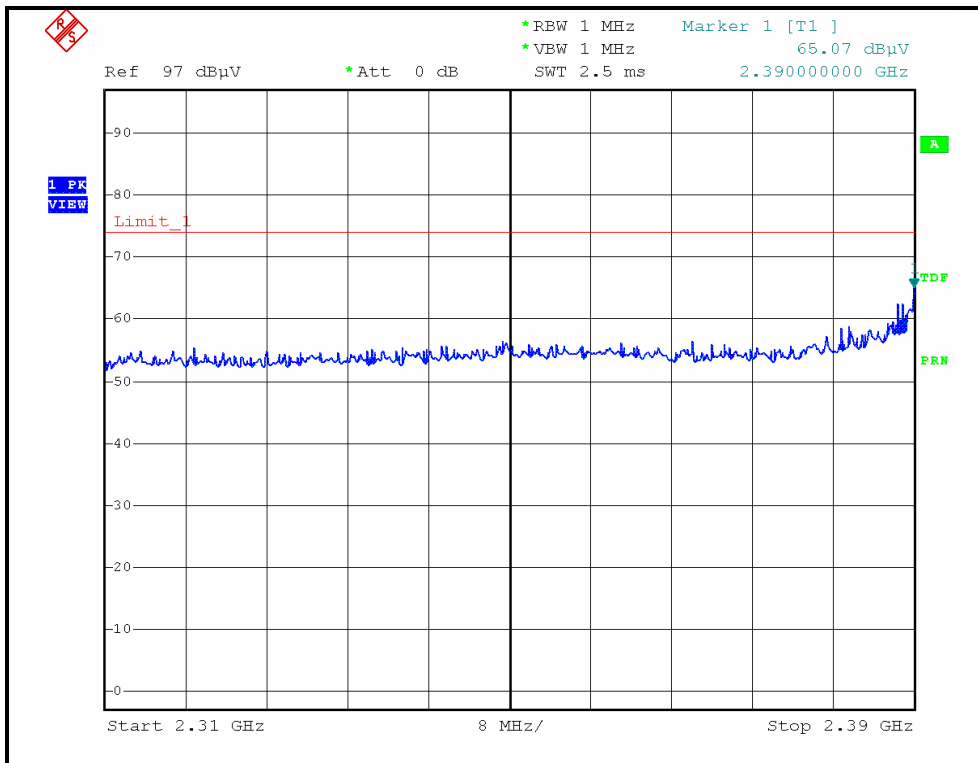



A D T

### RESTRICTED BANDEDGE (DRAFT 802.11n (20MHz) MODE, CH11, HORIZONTAL )

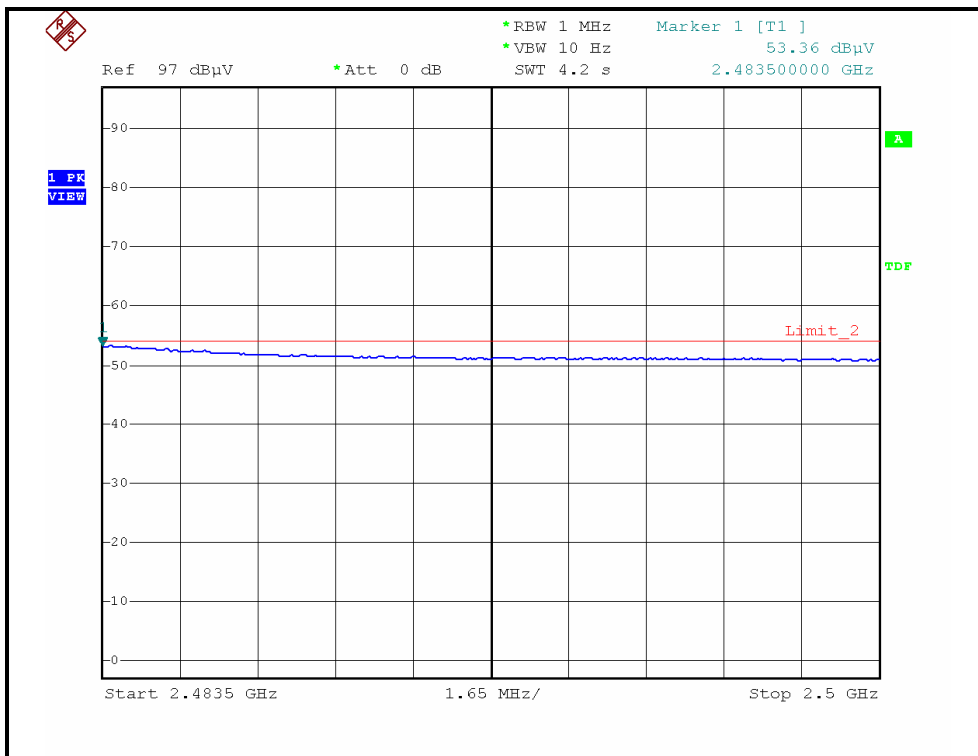
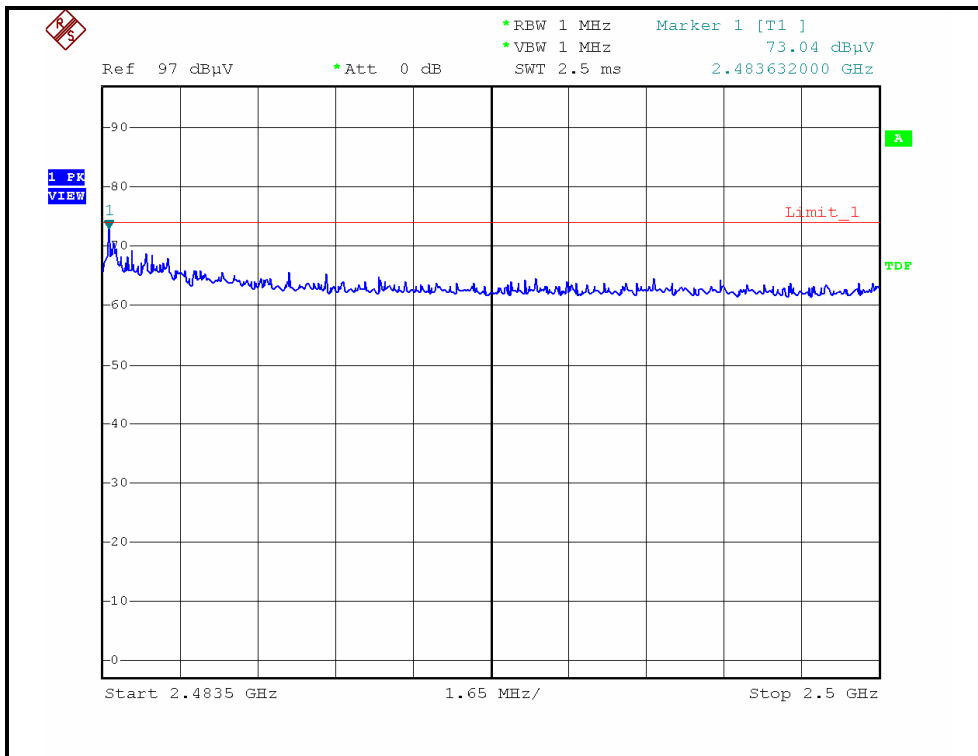



A D T

### RESTRICTED BANDEDGE (DRAFT 802.11n (20MHz) MODE,CH11, VERTICAL )

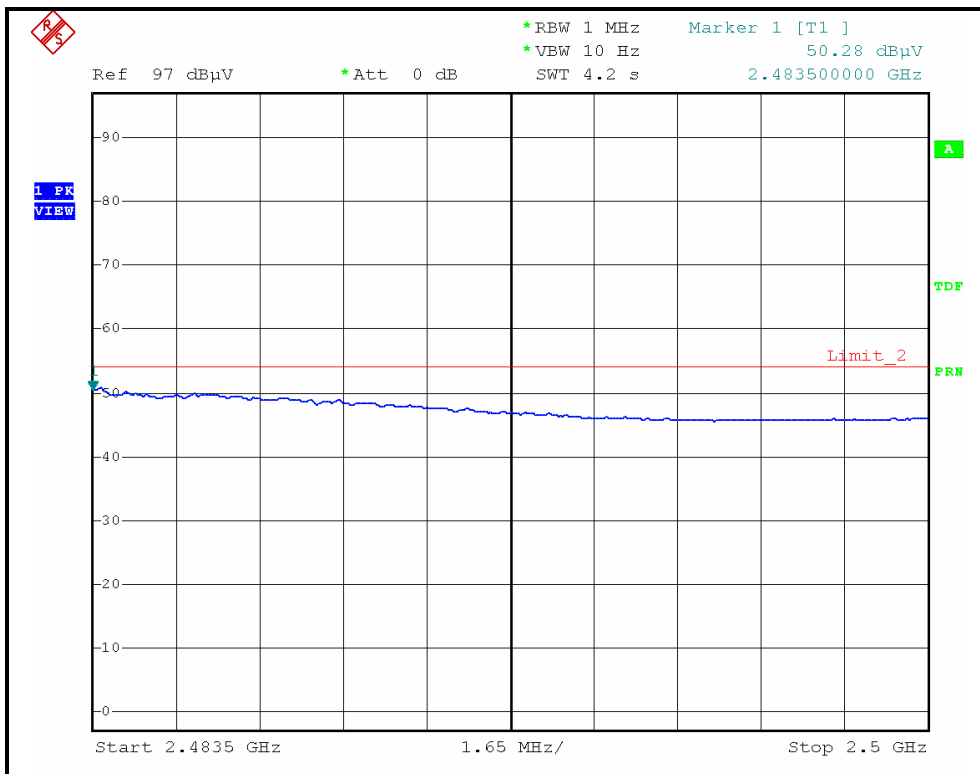
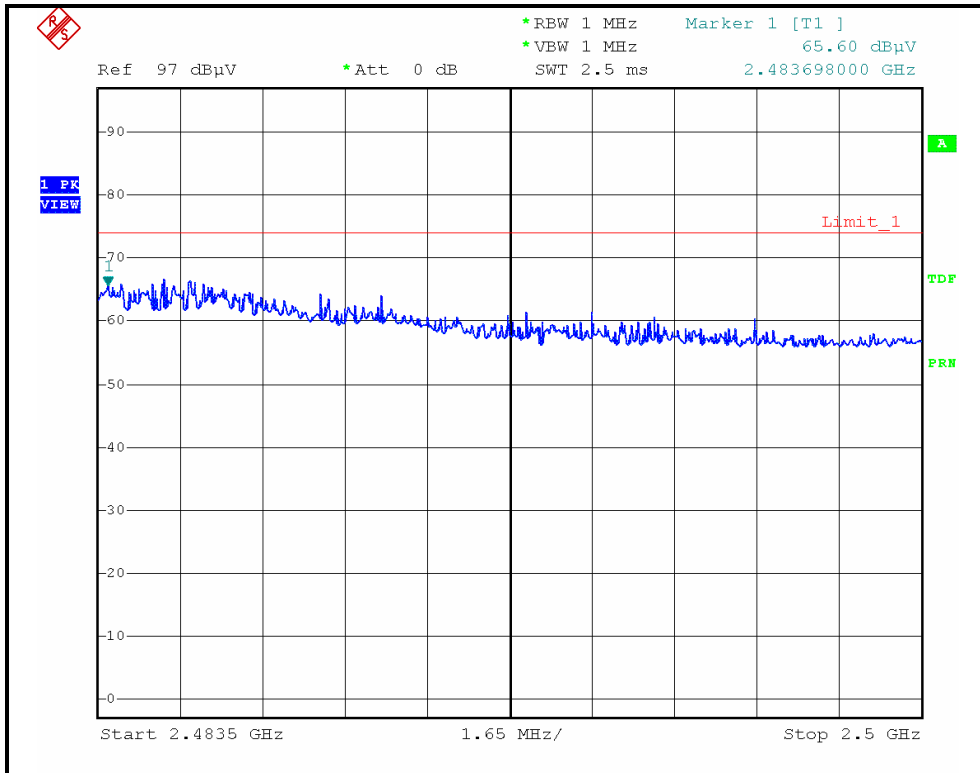



A D T

**DRAFT 802.11n (40MHz) OFDM MODULATION**

EUT TEST CONDITION		MEASUREMENT DETAIL	
CHANNEL	Channel 1	FREQUENCY RANGE	1 ~ 25GHz
INPUT POWER	120Vac, 60 Hz	DETECTOR FUNCTION	Peak (PK) Average (AV)
ENVIRONMENTAL CONDITIONS	30.0deg. C, 55.0%RH 965hPa	TESTED BY	Eric Lee

ANTENNA POLARITY & TEST DISTANCE: HORIZONTAL AT 3 M								
NO.	FREQ. (MHz)	EMISSION LEVEL (dBuV/m)	LIMIT (dBuV/m)	MARGIN (dB)	ANTENNA HEIGHT (m)	TABLE ANGLE (Degree)	RAW VALUE (dBuV)	CORRECTION FACTOR (dB/m)
1	2390.00	73.35 PK	74.00	-0.65	1.34 H	69	43.29	30.06
2	2390.00	52.95 AV	54.00	-1.05	1.34 H	69	22.89	30.06
3	*2422.00	113.78 PK			1.35 H	69	83.59	30.19
4	*2422.00	103.31 AV			1.35 H	69	73.12	30.19
5	4844.00	47.85 PK	74.00	-26.15	1.38 H	41	12.35	35.50
6	4844.00	33.63 AV	54.00	-20.37	1.38 H	41	-1.87	35.50
7	7266.00	53.40 PK	74.00	-20.60	1.34 H	89	11.47	41.93
8	7266.00	39.10 AV	54.00	-14.90	1.34 H	89	-2.83	41.93
ANTENNA POLARITY & TEST DISTANCE: VERTICAL AT 3 M								
NO.	FREQ. (MHz)	EMISSION LEVEL (dBuV/m)	LIMIT (dBuV/m)	MARGIN (dB)	ANTENNA HEIGHT (m)	TABLE ANGLE (Degree)	RAW VALUE (dBuV)	CORRECTION FACTOR (dB/m)
1	2390.00	64.20 PK	74.00	-9.80	1.63 V	248	34.14	30.06
2	2390.00	49.61 AV	54.00	-4.39	1.63 V	248	19.55	30.06
3	*2422.00	110.60 PK			1.36 V	259	80.41	30.19
4	*2422.00	100.30 AV			1.36 V	259	70.11	30.19
5	4844.00	47.90 PK	74.00	-26.10	1.00 V	124	12.40	35.50
6	4844.00	33.80 AV	54.00	-20.20	1.00 V	124	-1.70	35.50
7	7266.00	53.50 PK	74.00	-20.50	1.14 V	33	11.57	41.93
8	7266.00	39.40 AV	54.00	-14.60	1.14 V	33	-2.53	41.93

- REMARKS:**
1. Emission level (dBuV/m) = Raw Value (dBuV) + Correction Factor (dB/m).
  2. Correction Factor (dB/m) = Antenna Factor (dB/m) + Cable Factor (dB).
  3. The other emission levels were very low against the limit.
  4. Margin value = Emission level – Limit value.
  5. “ \* “: Fundamental frequency.



A D T

EUT TEST CONDITION		MEASUREMENT DETAIL	
CHANNEL	Channel 4	FREQUENCY RANGE	1 ~ 25GHz
INPUT POWER	120Vac, 60 Hz	DETECTOR FUNCTION	Peak (PK) Average (AV)
ENVIRONMENTAL CONDITIONS	30.0deg. C, 55.0%RH 965hPa	TESTED BY	Eric Lee

ANTENNA POLARITY & TEST DISTANCE: HORIZONTAL AT 3 M								
NO.	FREQ. (MHz)	EMISSION LEVEL (dBuV/m)	LIMIT (dBuV/m)	MARGIN (dB)	ANTENNA HEIGHT (m)	TABLE ANGLE (Degree)	RAW VALUE (dBuV)	CORRECTION FACTOR (dB/m)
1	2390.00	65.77 PK	74.00	-8.23	1.34 H	70	35.71	30.06
2	2390.00	53.22 AV	54.00	-0.78	1.34 H	70	23.16	30.06
3	*2437.00	116.88 PK			1.33 H	69	86.64	30.24
4	*2437.00	106.20 AV			1.33 H	69	75.96	30.24
5	2483.50	65.05 PK	74.00	-8.95	1.35 H	68	34.62	30.43
6	2483.50	52.70 AV	54.00	-1.30	1.35 H	68	22.27	30.43
7	4874.00	47.81 PK	74.00	-26.19	1.02 H	24	12.26	35.55
8	4874.00	33.86 AV	54.00	-20.14	1.02 H	24	-1.69	35.55
9	7311.00	53.67 PK	74.00	-20.33	1.39 H	62	11.63	42.04
10	7311.00	39.42 AV	54.00	-14.58	1.39 H	62	-2.62	42.04

ANTENNA POLARITY & TEST DISTANCE: VERTICAL AT 3 M								
NO.	FREQ. (MHz)	EMISSION LEVEL (dBuV/m)	LIMIT (dBuV/m)	MARGIN (dB)	ANTENNA HEIGHT (m)	TABLE ANGLE (Degree)	RAW VALUE (dBuV)	CORRECTION FACTOR (dB/m)
1	2390.00	62.60 PK	74.00	-11.40	1.31 V	236	32.54	30.06
2	2390.00	50.60 AV	54.00	-3.40	1.31 V	236	20.54	30.06
3	*2437.00	113.40 PK			1.37 V	213	83.16	30.24
4	*2437.00	103.80 AV			1.37 V	213	73.56	30.24
5	4874.00	48.20 PK	74.00	-25.80	1.00 V	129	12.65	35.55
6	4874.00	34.10 AV	54.00	-19.90	1.00 V	129	-1.45	35.55
7	7311.00	53.80 PK	74.00	-20.20	1.52 V	69	11.76	42.04
8	7311.00	39.60 AV	54.00	-14.40	1.52 V	69	-2.44	42.04

- REMARKS:**
1. Emission level (dBuV/m) = Raw Value (dBuV) + Correction Factor (dB/m).
  2. Correction Factor (dB/m) = Antenna Factor (dB/m) + Cable Factor (dB).
  3. The other emission levels were very low against the limit.
  4. Margin value = Emission level – Limit value.
  5. “ \* “: Fundamental frequency.



A D T

EUT TEST CONDITION		MEASUREMENT DETAIL	
CHANNEL	Channel 7	FREQUENCY RANGE	1 ~ 25GHz
INPUT POWER	120Vac, 60 Hz	DETECTOR FUNCTION	Peak (PK) Average (AV)
ENVIRONMENTAL CONDITIONS	30.0deg. C, 55.0%RH 965hPa	TESTED BY	Eric Lee

**ANTENNA POLARITY & TEST DISTANCE: HORIZONTAL AT 3 M**

NO.	FREQ. (MHz)	EMISSION LEVEL (dBuV/m)	LIMIT (dBuV/m)	MARGIN (dB)	ANTENNA HEIGHT (m)	TABLE ANGLE (Degree)	RAW VALUE (dBuV)	CORRECTION FACTOR (dB/m)
1	*2452.00	114.36 PK			1.35 H	69	84.06	30.30
2	*2452.00	103.02 AV			1.35 H	69	72.72	30.30
3	2483.50	73.21 PK	74.00	-0.79	1.34 H	67	42.78	30.43
4	2483.50	53.10 AV	54.00	-0.90	1.34 H	67	22.67	30.43
5	4904.00	47.62 PK	74.00	-26.38	1.31 H	56	12.02	35.60
6	4904.00	33.74 AV	54.00	-20.26	1.31 H	56	-1.86	35.60
7	7356.00	53.91 PK	74.00	-20.09	1.40 H	71	11.75	42.16
8	7356.00	39.98 AV	54.00	-14.02	1.40 H	71	-2.18	42.16

**ANTENNA POLARITY & TEST DISTANCE: VERTICAL AT 3 M**

NO.	FREQ. (MHz)	EMISSION LEVEL (dBuV/m)	LIMIT (dBuV/m)	MARGIN (dB)	ANTENNA HEIGHT (m)	TABLE ANGLE (Degree)	RAW VALUE (dBuV)	CORRECTION FACTOR (dB/m)
1	*2452.00	111.24 PK			1.34 V	212	80.94	30.30
2	*2452.00	101.30 AV			1.34 V	212	71.00	30.30
3	2483.50	70.79 PK	74.00	-3.21	1.36 V	257	40.36	30.43
4	2483.50	52.76 AV	54.00	-1.24	1.36 V	257	22.33	30.43
5	4904.00	48.60 PK	74.00	-25.40	1.00 V	124	13.00	35.60
6	4904.00	35.40 AV	54.00	-18.60	1.00 V	124	-0.20	35.60
7	7356.00	54.20 PK	74.00	-19.80	1.54 V	88	12.04	42.16
8	7356.00	39.90 AV	54.00	-14.10	1.54 V	88	-2.26	42.16

- REMARKS:**
1. Emission level (dBuV/m) = Raw Value (dBuV) + Correction Factor (dB/m).
  2. Correction Factor (dB/m) = Antenna Factor (dB/m) + Cable Factor (dB).
  3. The other emission levels were very low against the limit.
  4. Margin value = Emission level – Limit value.
  5. “ \* “: Fundamental frequency.





A D T

### RESTRICTED BANDEDGE (DRAFT 802.11n (40MHz) MODE, CH1, HORIZONTAL )

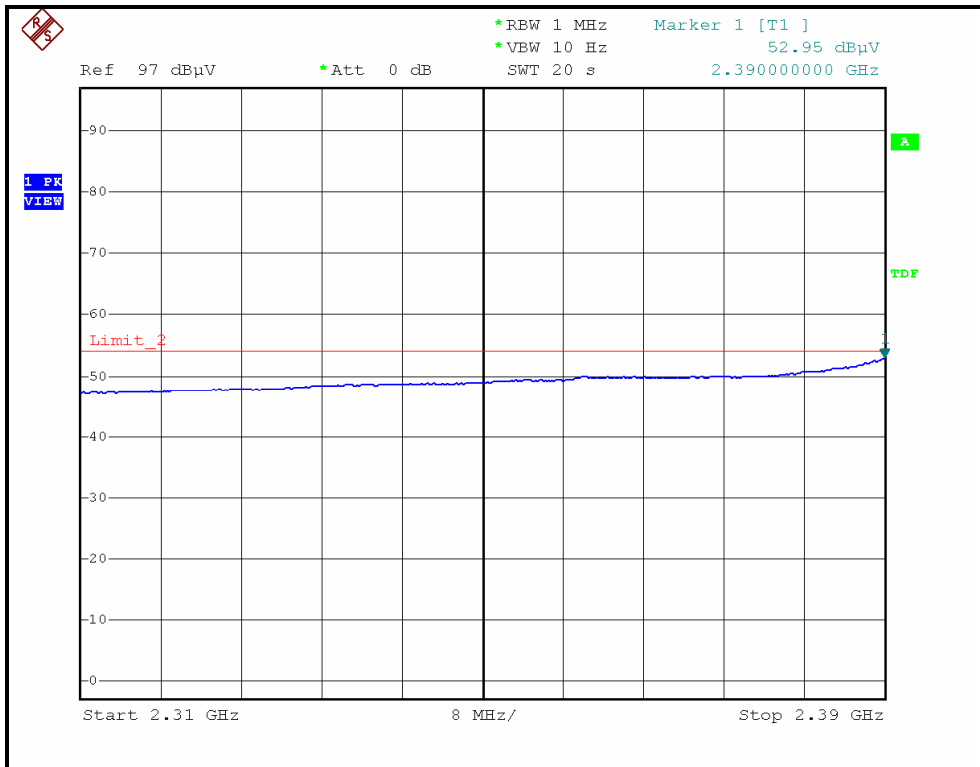
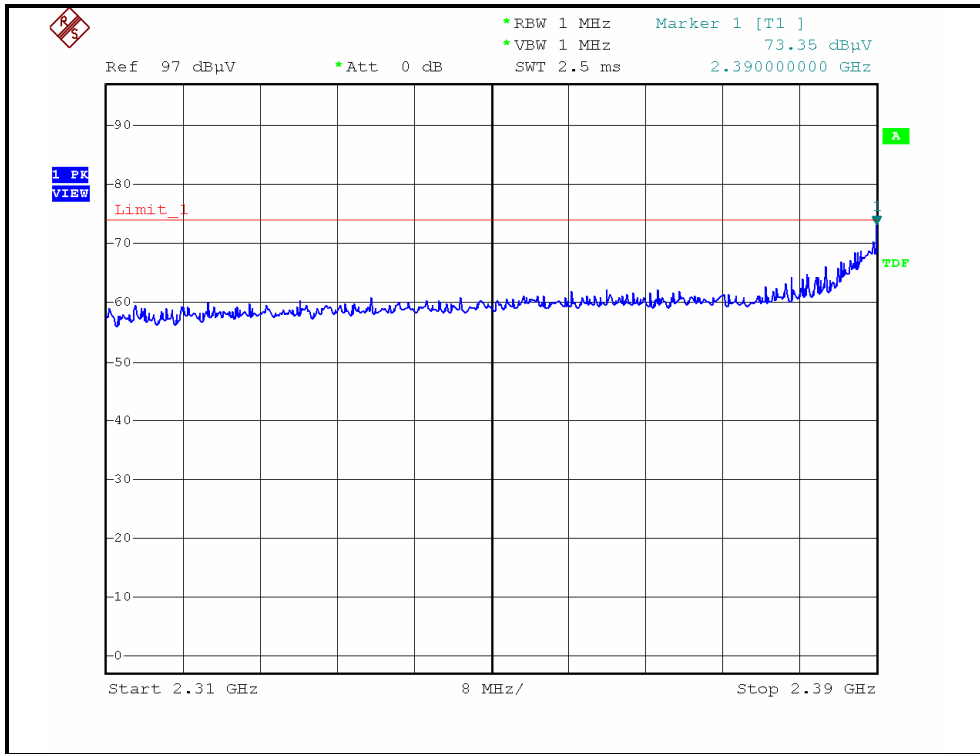



A D T

### RESTRICTED BANDEDGE (DRAFT 802.11n (40MHz) MODE,CH1, VERTICAL )

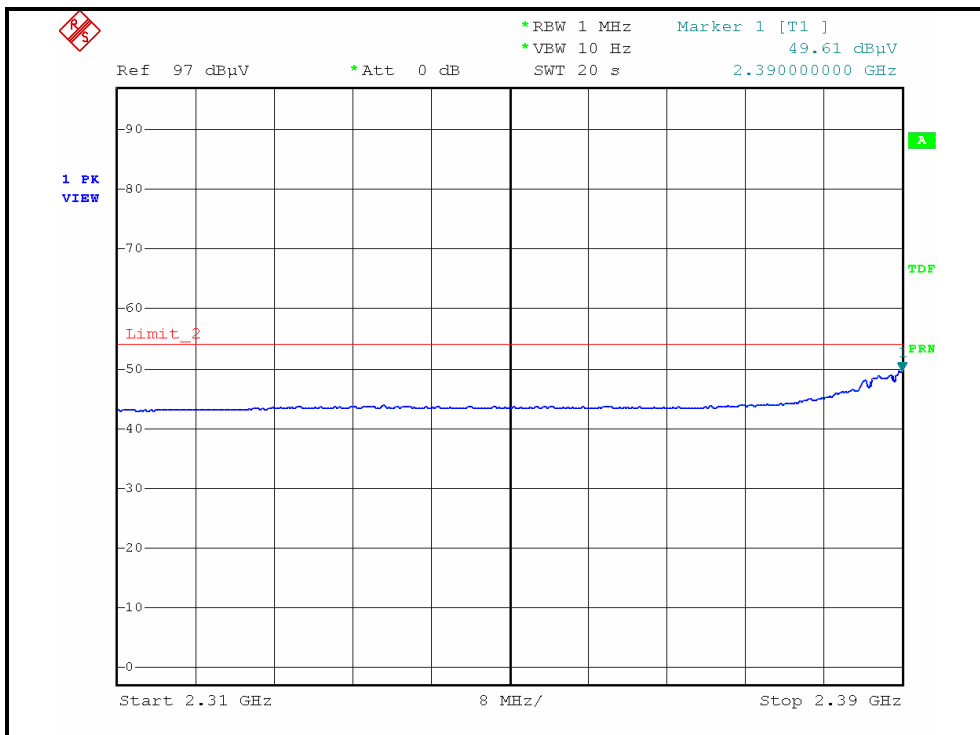
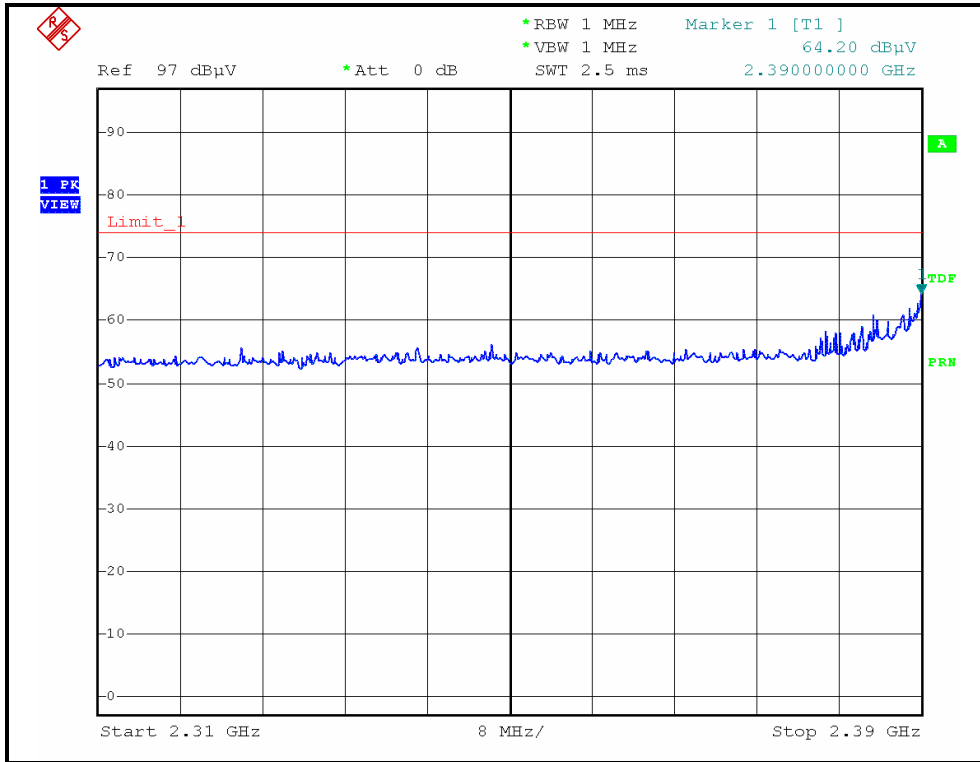



A D T

### RESTRICTED BANDEDGE (DRAFT 802.11n (40MHz) MODE,CH7, HORIZONTAL )

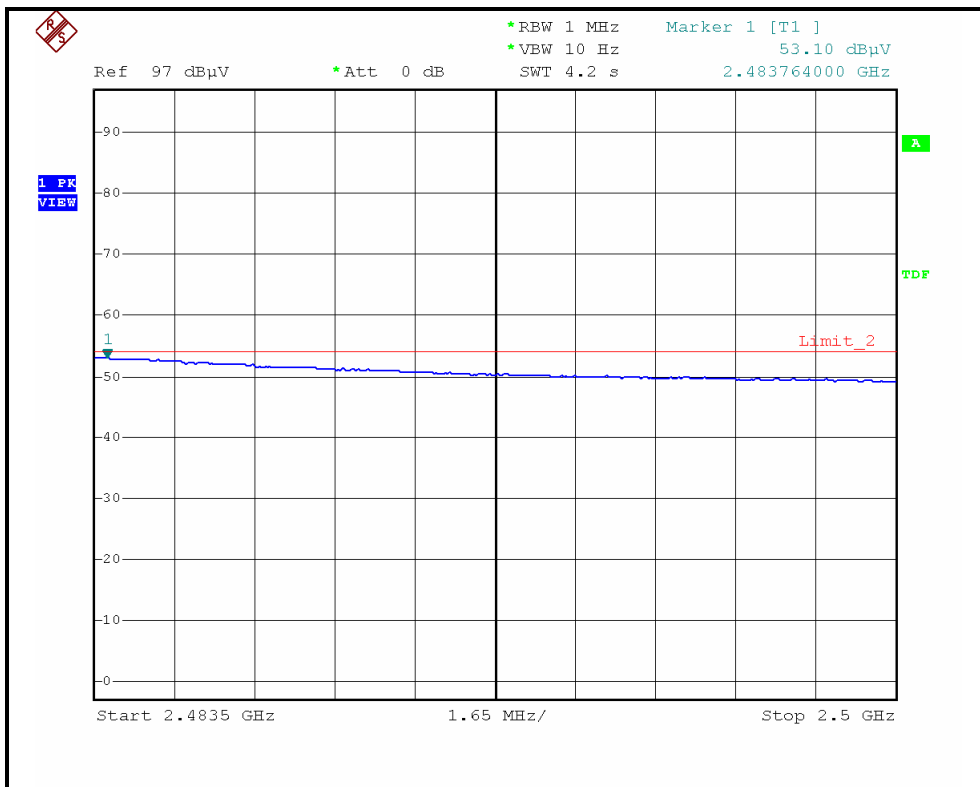
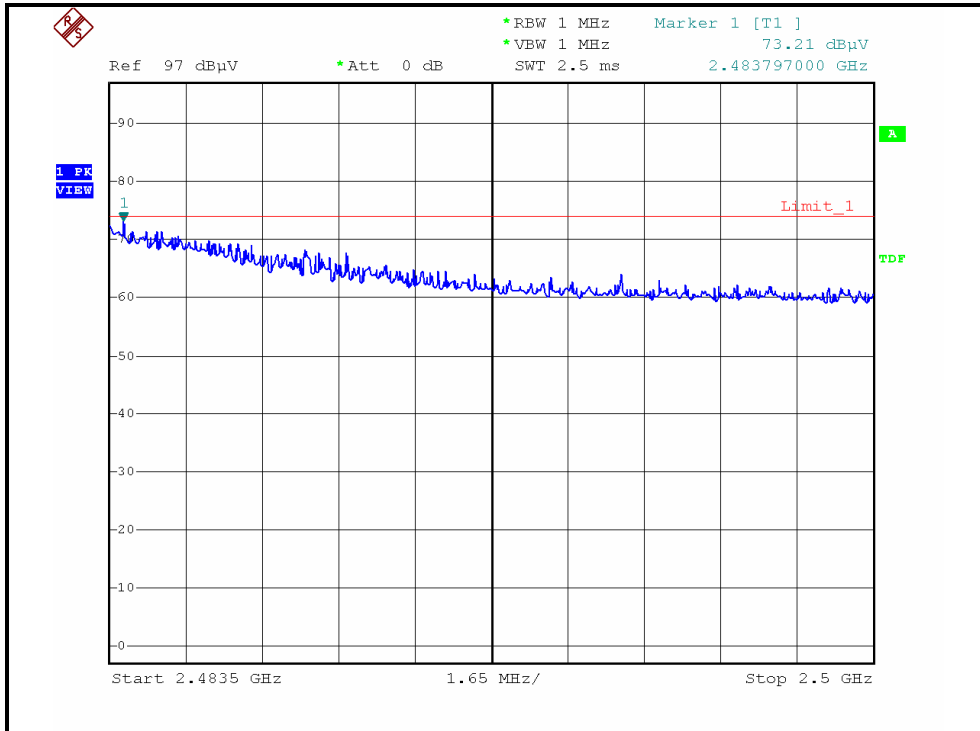



A D T

### RESTRICTED BANDEDGE (DRAFT 802.11n (40MHz) MODE,CH7, VERTICAL )

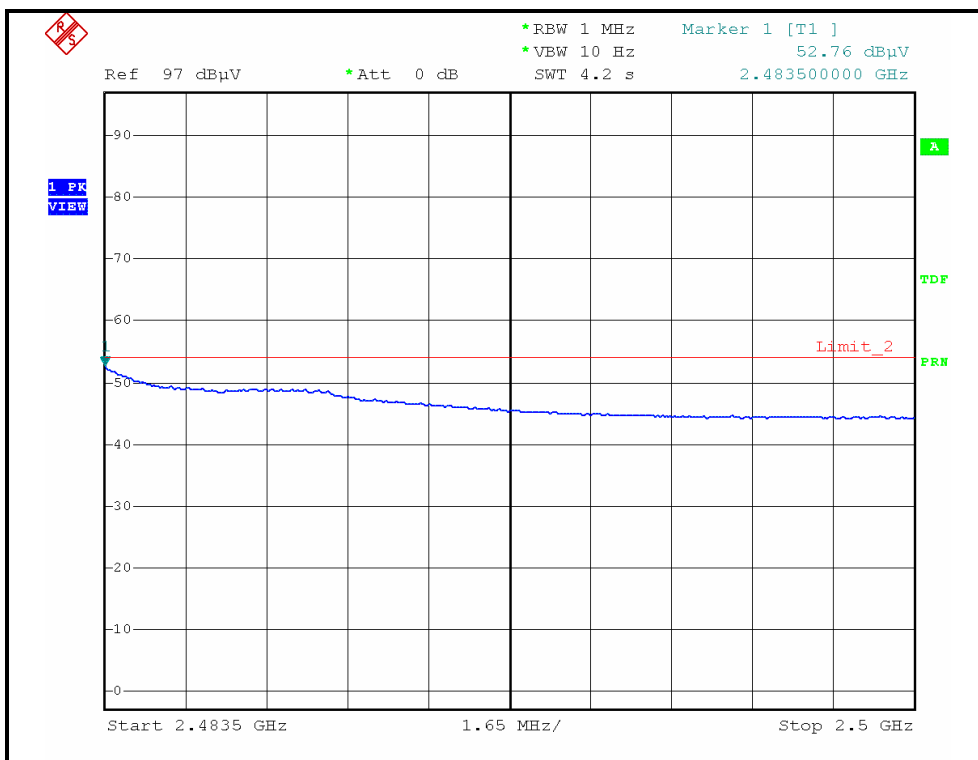
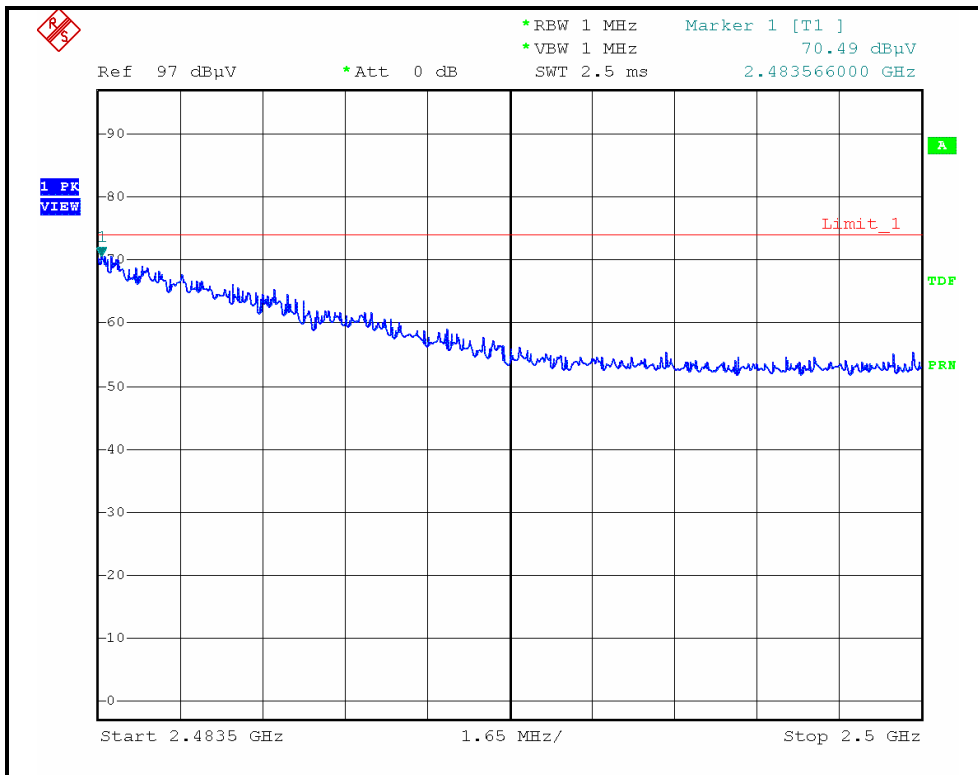



A D T

## 4.2.12 TEST RESULTS –ANTENNA 12

## BELOW 1GHz WORST-CASE DATA : 802.11b DSSS MODULATION

EUT TEST CONDITION		MEASUREMENT DETAIL	
CHANNEL	Channel 1	FREQUENCY RANGE	Below 1000MHz
INPUT POWER	120Vac, 60 Hz	DETECTOR FUNCTION	Quasi-Peak
ENVIRONMENTAL CONDITIONS	25.0deg. C, 72.0%RH 965hPa	TESTED BY	Frank Liu

ANTENNA POLARITY & TEST DISTANCE: HORIZONTAL AT 3 M								
NO.	FREQ. (MHz)	EMISSION LEVEL (dBuV/m)	LIMIT (dBuV/m)	MARGIN (dB)	ANTENNA HEIGHT (m)	TABLE ANGLE (Degree)	RAW VALUE (dBuV)	CORRECTION FACTOR (dB/m)
1	125.00	29.84 QP	43.50	-13.66	2.68 H	58	16.77	13.07
2	250.00	42.67 QP	46.00	-3.33	1.00 H	243	28.42	14.25
3	274.00	39.23 QP	46.00	-6.77	1.06 H	67	23.73	15.50
4	375.00	40.54 QP	46.00	-5.46	1.04 H	73	21.73	18.81
5	649.99	43.19 QP	46.00	-2.81	1.13 H	175	17.66	25.53
6	749.99	41.27 QP	46.00	-4.73	1.06 H	109	14.36	26.91
7	999.98	36.43 QP	54.00	-17.57	1.11 H	211	5.69	30.74
ANTENNA POLARITY & TEST DISTANCE: VERTICAL AT 3 M								
NO.	FREQ. (MHz)	EMISSION LEVEL (dBuV/m)	LIMIT (dBuV/m)	MARGIN (dB)	ANTENNA HEIGHT (m)	TABLE ANGLE (Degree)	RAW VALUE (dBuV)	CORRECTION FACTOR (dB/m)
1	57.21	32.64 QP	40.00	-7.36	1.00 V	263	5.48	27.16
2	125.00	29.84 QP	43.50	-13.66	1.00 V	69	2.68	27.16
3	250.00	28.73 QP	46.00	-17.27	1.00 V	24	1.57	27.16
4	375.00	39.89 QP	46.00	-6.11	1.06 V	216	12.73	27.16
5	500.00	34.73 QP	46.00	-11.27	1.00 V	214	7.57	27.16
6	600.00	37.59 QP	46.00	-8.41	1.00 V	326	10.43	27.16
7	650.00	39.66 QP	46.00	-6.34	1.00 V	217	12.50	27.16

- REMARKS:**
1. Emission level (dBuV/m) = Raw Value (dBuV) + Correction Factor (dB/m).
  2. Correction Factor (dB/m) = Antenna Factor (dB/m) + Cable Factor (dB).
  3. The other emission levels were very low against the limit.
  4. Margin value = Emission level – Limit value.



**ABOVE 1GHz WORST-CASE DATA**

**802.11b DSSS MODULATION**

EUT TEST CONDITION		MEASUREMENT DETAIL	
CHANNEL	Channel 1	FREQUENCY RANGE	1 ~ 25GHz
INPUT POWER	120Vac, 60 Hz	DETECTOR FUNCTION	Peak (PK) Average (AV)
ENVIRONMENTAL CONDITIONS	25.0deg. C, 66.0%RH 965hPa	TESTED BY	Wen Yu

**ANTENNA POLARITY & TEST DISTANCE: HORIZONTAL AT 3 M**

NO.	FREQ. (MHz)	EMISSION LEVEL (dBuV/m)	LIMIT (dBuV/m)	MARGIN (dB)	ANTENNA HEIGHT (m)	TABLE ANGLE (Degree)	RAW VALUE (dBuV)	CORRECTION FACTOR (dB/m)
1	2386.40	55.60 PK	74.00	-18.40	1.00 H	46	25.55	30.05
2	2386.40	45.40 AV	54.00	-8.60	1.00 H	46	15.35	30.05
3	*2412.00	105.40 PK			1.00 H	62	75.25	30.15
4	*2412.00	101.40 AV			1.00 H	62	71.25	30.15
5	4824.00	46.40 PK	74.00	-27.60	1.04 H	243	10.94	35.46
6	4824.00	34.20 AV	54.00	-19.80	1.04 H	243	-1.26	35.46

**ANTENNA POLARITY & TEST DISTANCE: VERTICAL AT 3 M**

NO.	FREQ. (MHz)	EMISSION LEVEL (dBuV/m)	LIMIT (dBuV/m)	MARGIN (dB)	ANTENNA HEIGHT (m)	TABLE ANGLE (Degree)	RAW VALUE (dBuV)	CORRECTION FACTOR (dB/m)
1	2386.00	62.07 PK	74.00	-11.93	1.10 V	35	32.02	30.05
2	2386.00	53.12 AV	54.00	-0.88	1.10 V	35	23.07	30.05
3	*2412.00	116.79 PK			1.10 V	35	86.64	30.15
4	*2412.00	112.33 AV			1.10 V	35	82.18	30.15
5	4824.00	47.99 PK	74.00	-26.01	1.08 V	0	12.53	35.46
6	4824.00	35.04 AV	54.00	-18.96	1.08 V	0	-0.42	35.46

- REMARKS:**
1. Emission level (dBuV/m) = Raw Value (dBuV) + Correction Factor (dB/m).
  2. Correction Factor (dB/m) = Antenna Factor (dB/m) + Cable Factor (dB).
  3. The other emission levels were very low against the limit.
  4. Margin value = Emission level – Limit value.
  5. “ \* “: Fundamental frequency.



A D T

EUT TEST CONDITION		MEASUREMENT DETAIL	
CHANNEL	Channel 6	FREQUENCY RANGE	1 ~ 25GHz
INPUT POWER	120Vac, 60 Hz	DETECTOR FUNCTION	Peak (PK) Average (AV)
ENVIRONMENTAL CONDITIONS	25.0deg. C, 66.0%RH 965hPa	TESTED BY	Wen Yu

**ANTENNA POLARITY & TEST DISTANCE: HORIZONTAL AT 3 M**

NO.	FREQ. (MHz)	EMISSION LEVEL (dBuV/m)	LIMIT (dBuV/m)	MARGIN (dB)	ANTENNA HEIGHT (m)	TABLE ANGLE (Degree)	RAW VALUE (dBuV)	CORRECTION FACTOR (dB/m)
1	*2437.00	102.60 PK			1.00 H	74	72.36	30.24
2	*2437.00	98.40 AV			1.00 H	74	68.16	30.24
3	4874.00	47.40 PK	74.00	-26.60	1.09 H	254	11.85	35.55
4	4874.00	40.30 AV	54.00	-13.70	1.09 H	254	4.75	35.55
5	7311.00	58.20 PK	74.00	-15.80	1.01 H	21	16.16	42.04
6	7311.00	50.34 AV	54.00	-3.66	1.01 H	21	8.30	42.04

**ANTENNA POLARITY & TEST DISTANCE: VERTICAL AT 3 M**

NO.	FREQ. (MHz)	EMISSION LEVEL (dBuV/m)	LIMIT (dBuV/m)	MARGIN (dB)	ANTENNA HEIGHT (m)	TABLE ANGLE (Degree)	RAW VALUE (dBuV)	CORRECTION FACTOR (dB/m)
1	*2437.00	120.23 PK			1.10 V	35	89.99	30.24
2	*2437.00	115.71 AV			1.10 V	35	85.47	30.24
3	4874.00	49.76 PK	74.00	-24.24	1.40 V	93	14.21	35.55
4	4874.00	42.05 AV	54.00	-11.95	1.40 V	93	6.50	35.55
5	7311.00	61.14 PK	74.00	-12.86	1.21 V	16	19.10	42.04
6	7311.00	53.43 AV	54.00	-0.57	1.21 V	16	11.39	42.04

- REMARKS:**
1. Emission level (dBuV/m) = Raw Value (dBuV) + Correction Factor (dB/m).
  2. Correction Factor (dB/m) = Antenna Factor (dB/m) + Cable Factor (dB).
  3. The other emission levels were very low against the limit.
  4. Margin value = Emission level – Limit value.
  5. “ \* “: Fundamental frequency.



A D T

EUT TEST CONDITION		MEASUREMENT DETAIL	
CHANNEL	Channel 11	FREQUENCY RANGE	1 ~ 25GHz
INPUT POWER	120Vac, 60 Hz	DETECTOR FUNCTION	Peak (PK) Average (AV)
ENVIRONMENTAL CONDITIONS	25.0deg. C, 66.0%RH 965hPa	TESTED BY	Wen Yu

**ANTENNA POLARITY & TEST DISTANCE: HORIZONTAL AT 3 M**

NO.	FREQ. (MHz)	EMISSION LEVEL (dBuV/m)	LIMIT (dBuV/m)	MARGIN (dB)	ANTENNA HEIGHT (m)	TABLE ANGLE (Degree)	RAW VALUE (dBuV)	CORRECTION FACTOR (dB/m)
1	*2462.00	105.20 PK			1.00 H	51	74.86	30.34
2	*2462.00	101.10 AV			1.00 H	51	70.76	30.34
3	2487.00	55.75 PK	74.00	-18.25	1.00 H	53	25.31	30.44
4	2487.00	46.60 AV	54.00	-7.40	1.00 H	53	16.16	30.44
5	4924.00	46.10 PK	74.00	-27.90	1.05 H	194	10.47	35.63
6	4924.00	34.50 AV	54.00	-19.50	1.05 H	194	-1.13	35.63
7	7386.00	51.34 PK	74.00	-22.66	1.01 H	46	9.11	42.23
8	7386.00	40.27 AV	54.00	-13.73	1.01 H	46	-1.96	42.23

**ANTENNA POLARITY & TEST DISTANCE: VERTICAL AT 3 M**

NO.	FREQ. (MHz)	EMISSION LEVEL (dBuV/m)	LIMIT (dBuV/m)	MARGIN (dB)	ANTENNA HEIGHT (m)	TABLE ANGLE (Degree)	RAW VALUE (dBuV)	CORRECTION FACTOR (dB/m)
1	*2462.00	116.60 PK			1.11 V	45	86.26	30.34
2	*2462.00	112.09 AV			1.11 V	45	81.75	30.34
3	2487.00	62.66 PK	74.00	-11.34	1.10 V	44	32.22	30.44
4	2487.00	52.69 AV	54.00	-1.31	1.10 V	44	22.25	30.44
5	4924.00	49.32 PK	74.00	-24.68	1.07 V	3	13.69	35.63
6	4924.00	35.83 AV	54.00	-18.17	1.07 V	3	0.20	35.63
7	7386.00	55.48 PK	74.00	-18.52	1.37 V	5	13.25	42.23
8	7386.00	44.24 AV	54.00	-9.76	1.37 V	5	2.01	42.23

- REMARKS:**
1. Emission level (dBuV/m) = Raw Value (dBuV) + Correction Factor (dB/m).
  2. Correction Factor (dB/m) = Antenna Factor (dB/m) + Cable Factor (dB).
  3. The other emission levels were very low against the limit.
  4. Margin value = Emission level – Limit value.
  5. “ \* “: Fundamental frequency.





A D T

### RESTRICTED BANDEDGE (802.11b MODE,CH1, HORIZONTAL )

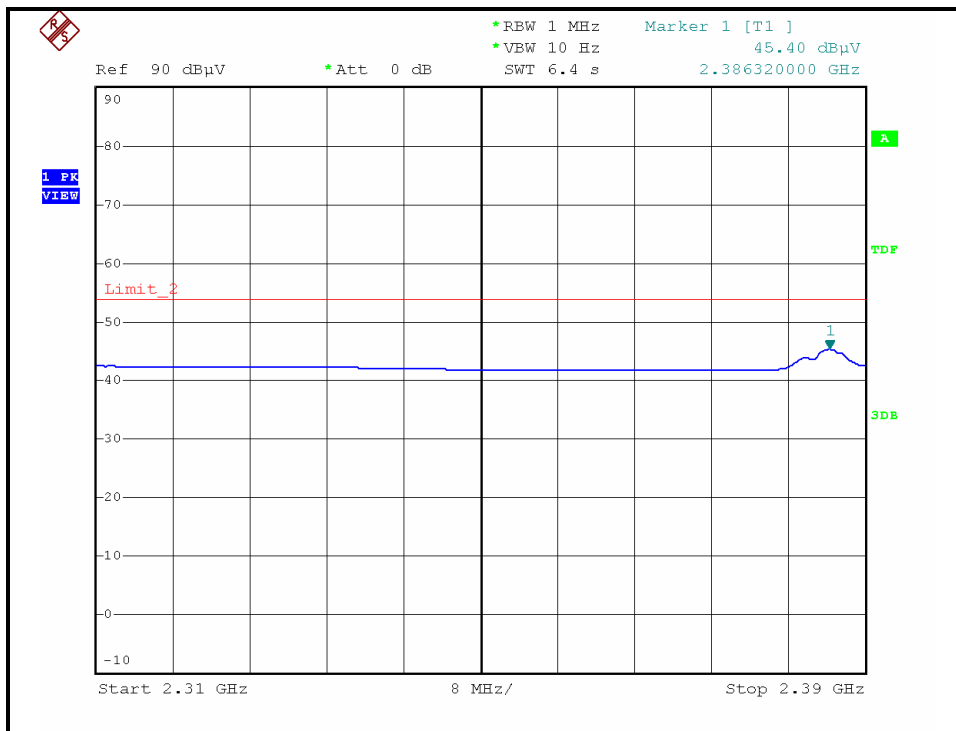
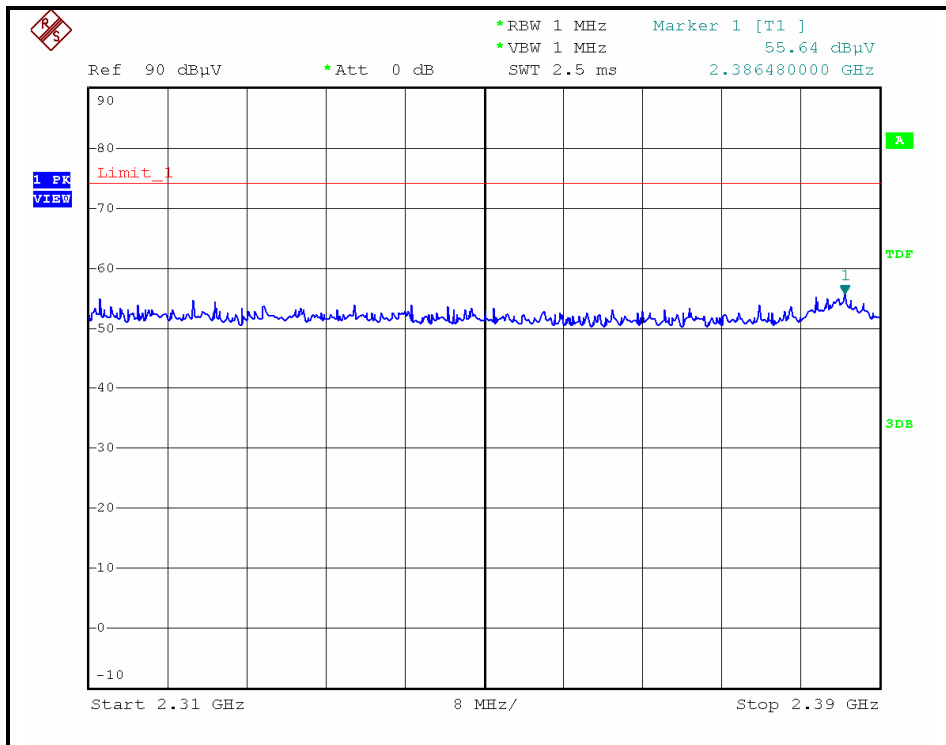





A D T

### RESTRICTED BANDEDGE (802.11b MODE,CH11, HORIZONTAL )

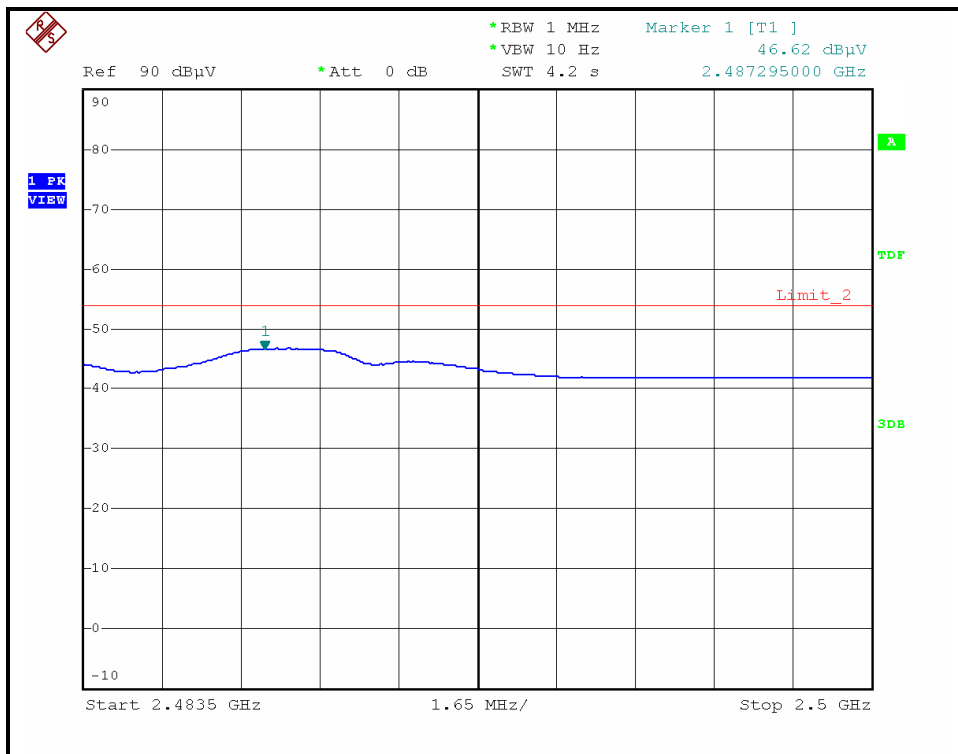
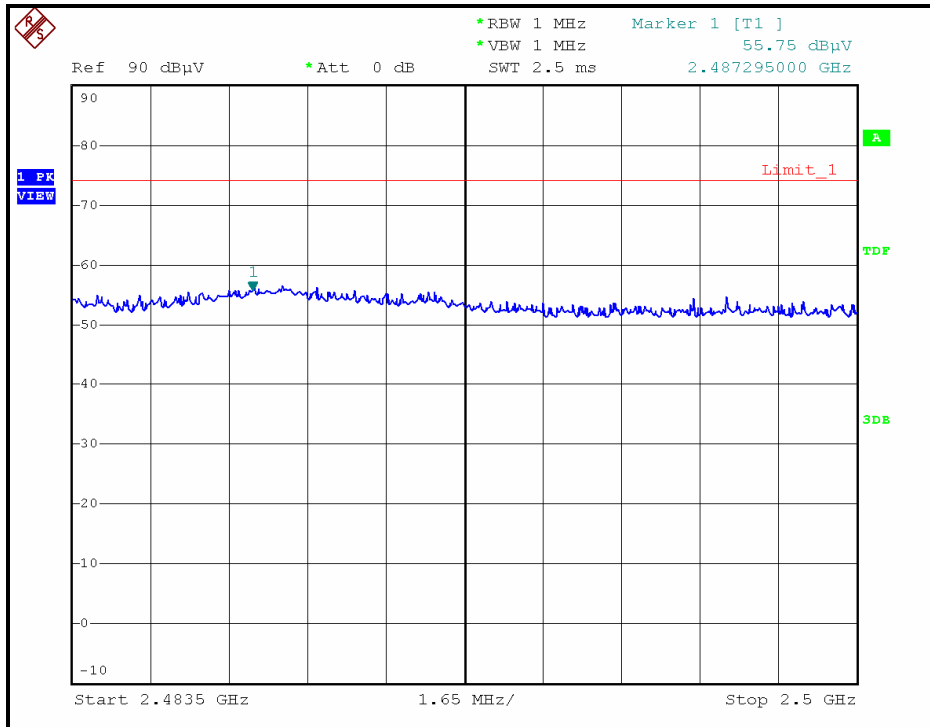



A D T

### RESTRICTED BANDEDGE (802.11b MODE, CH11, VERTICAL )

