



SPORTON International Inc.

No. 52, Hwa Ya 1st Rd., Kwei-Shan Hsiang, TaoYuan Hsien, Taiwan, R.O.C.
Ph: 886-3-327-3456 / FAX: 886-3-327-0973 / www.sporton.com.tw

FCC RADIO TEST REPORT

Applicant's company	Motorola, Inc.
Applicant Address	One Motorola Plaza Holtsville, NY 11742 USA
FCC ID	UZ7AP7131
Manufacturer's company	Joy Technology(ShenZhen) Corporation
Manufacturer Address	Hengkeng Ind., Shanpai, shangwu, Aiqun Rd., Shiyao Town, Shenzhen, 518108, China

Product Name	11 a/b/g/n Access Point Module
Brand Name	Motorola
Model Name	AP-7131-MB82
Test Rule Part(s)	47 CFR FCC Part 15 Subpart E § 15.407
Test Freq. Range	5150 ~ 5350MHz / 5470 ~ 5725MHz
Received Date	Feb. 15, 2008
Final Test Date	Apr. 2, 2008
Submission Type	Class II Change
Operating Mode	Master

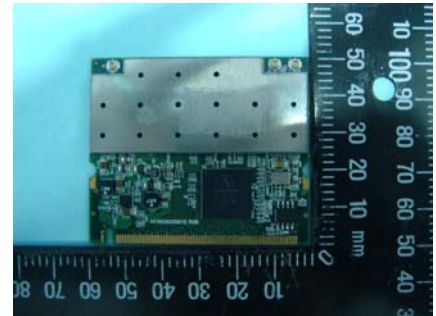

Statement

Test result included is only for the 802.11a (5150 ~ 5350MHz / 5470 ~ 5725MHz) of the product.

The test result in this report refers exclusively to the presented test model / sample.

Without written approval of SPORTON International Inc., the test report shall not be reproduced except in full.

The measurements and test results shown in this test report were made in accordance with the procedures and found in compliance with the limit given in **ANSI C63.4-2003** and **47 CFR FCC Part 15 Subpart E**.

The test equipment used to perform the test is calibrated and traceable to NML/ROC.



Testing Laboratory
1190



Table of Contents

1. CERTIFICATE OF COMPLIANCE	1
2. SUMMARY OF THE TEST RESULT	2
3. GENERAL INFORMATION	3
3.1. Product Details.....	3
3.2. Accessories.....	3
3.3. Table for Filed Antenna.....	4
3.4. Table for Carrier Frequencies	5
3.5. Table for Test Modes.....	5
3.6. Table for Testing Locations.....	6
3.7. Table for Multiple Listing & Class II Change	6
3.8. Table for Supporting Units	6
3.9. Table for Parameters of Test Software Setting	6
3.10. Test Configurations	8
4. TEST RESULT	14
4.1. AC Power Line Conducted Emissions Measurement.....	14
4.2. 99% Occupied Bandwidth Measurement	24
4.3. Maximum Conducted Output Power Measurement.....	47
4.4. Power Spectral Density Measurement	113
4.5. Peak Excursion Measurement	136
4.6. Radiated Emissions Measurement	159
4.7. Band Edge Emissions Measurement	249
4.8. Frequency Stability Measurement	270
4.9. Antenna Requirements	275
5. LIST OF MEASURING EQUIPMENTS	276
6. TEST LOCATION.....	277
7. TAF CERTIFICATE OF ACCREDITATION	278
APPENDIX A. PHOTOGRAPHS OF EUT.....	A1 ~ A20
APPENDIX B. TEST PHOTOS.....	B1 ~ B37
APPENDIX C. MAXIMUM PERMISSIBLE EXPOSURE.....	C1 ~ C3



History of This Test Report

Original Issue Date: Jul. 07, 2008

Report No.: FR821502-02AA

- No additional attachment.
- Additional attachment were issued as following record:

Attachment No.	Issue Date	Description



1. CERTIFICATE OF COMPLIANCE

Product Name : 11 a/b/g/n Access Point Module
Brand Name : Motorola
Model Name : AP-7131-MB82
Applicant : Motorola, Inc.
Test Rule Part(s) : 47 CFR FCC Part 15 Subpart E § 15.407

Sporton International as requested by the applicant to evaluate the EMC performance of the product sample received on Feb. 15, 2008 would like to declare that the tested sample has been evaluated and found to be in compliance with the tested rule parts. The data recorded as well as the test configuration specified is true and accurate for showing the sample's EMC nature.

Wayne Hsu
SPORTON INTERNATIONAL INC.

2. SUMMARY OF THE TEST RESULT

Applied Standard: 47 CFR FCC Part 15 Subpart E				
Part	Rule Section	Description of Test	Result	Under Limit
4.1	15.207	AC Power Line Conducted Emissions	Complies	13.00 dB
4.2	15.407(a)	26dB Spectrum Bandwidth	Complies	-
4.3	15.407(a)	Maximum Conducted Output Power	Complies	0.08dB
4.4	15.407(a)	Power Spectral Density	Complies	1.74 dB
4.5	15.407(a)	Peak Excursion	Complies	6.10 dB
4.6	15.407(b)	Radiated Emissions	Complies	0.21 dB
4.7	15.407(b)	Band Edge Emissions	Complies	0.16 dB
4.8	15.407(g)	Frequency Stability	Complies	-
4.9	15.203	Antenna Requirements	Complies	-

Test Items	Uncertainty	Remark
AC Power Line Conducted Emissions	±2.3dB	Confidence levels of 95%
Maximum Conducted Output Power	±0.5dB	Confidence levels of 95%
Power Spectral Density	±0.5dB	Confidence levels of 95%
Peak Excursion	±0.5dB	Confidence levels of 95%
26dB Spectrum Bandwidth / Frequency Stability	±8.5×10 ⁻⁸	Confidence levels of 95%
Radiated Emissions (9kHz~30MHz)	±0.8dB	Confidence levels of 95%
Radiated Emissions (30MHz~1000MHz)	±1.9dB	Confidence levels of 95%
Radiated / Band Edge Emissions (1GHz~18GHz)	±1.9dB	Confidence levels of 95%
Radiated Emissions (18GHz~40GHz)	±1.9dB	Confidence levels of 95%
Temperature	±0.7°C	Confidence levels of 95%
Humidity	±3.2%	Confidence levels of 95%
DC / AC Power Source	±1.4%	Confidence levels of 95%

3. GENERAL INFORMATION

3.1. Product Details

Items	Description
Product Type	WLAN (3TX, 3RX)
Radio Type	Intentional Transceiver
Power Type	From Host System
Modulation	OFDM for IEEE 802.11a
Data Modulation	OFDM (BPSK / QPSK / 16QAM / 64QAM)
Data Rate (Mbps)	OFDM (6/9/12/18/24/36/48/54)
Frequency Range	5150 ~ 5350MHz / 5470 ~ 5725MHz
Channel Number	11a: 19
Channel Band Width (99%)	11a: 17.94MHz
Conducted Output Power	Band 1: 16.92 dBm ; Band 2: 23.27 dBm ; Band 3: 23.30 dBm
Carrier Frequencies	Please refer to section 3.4
Antenna	Please refer to section 3.3

Antenna & Band width

Antenna	Three (TX)	
Band width Mode	20 MHz	40 MHz
11a	V	X

3.2. Accessories

N/A

3.3. Table for Filed Antenna

For 5GHz Band

Ant.	Brand	Model Name	Antenna Type	Connector	Gain (dBi)
1	SYMBOL	ML-2452-APA2-01R	Dipole Antenna	Reversed-SMA	4
5	SYMBOL	ML-2452-APA2-FAC	embedded Antenna	Reversed-SMA	4.5
6	SYMBOL	ML-5299-WPNA1-01	Patch Antenna	Reversed-SMA	13
7	SYMBOL	ML-5299-HPA1-01	Omni Antenna	Reversed-SMA	5

Note : The EUT has four antennas.

Connect (J2) & Connect (J3) & Connect (J4) could Receiver / Transmitter simultaneously.

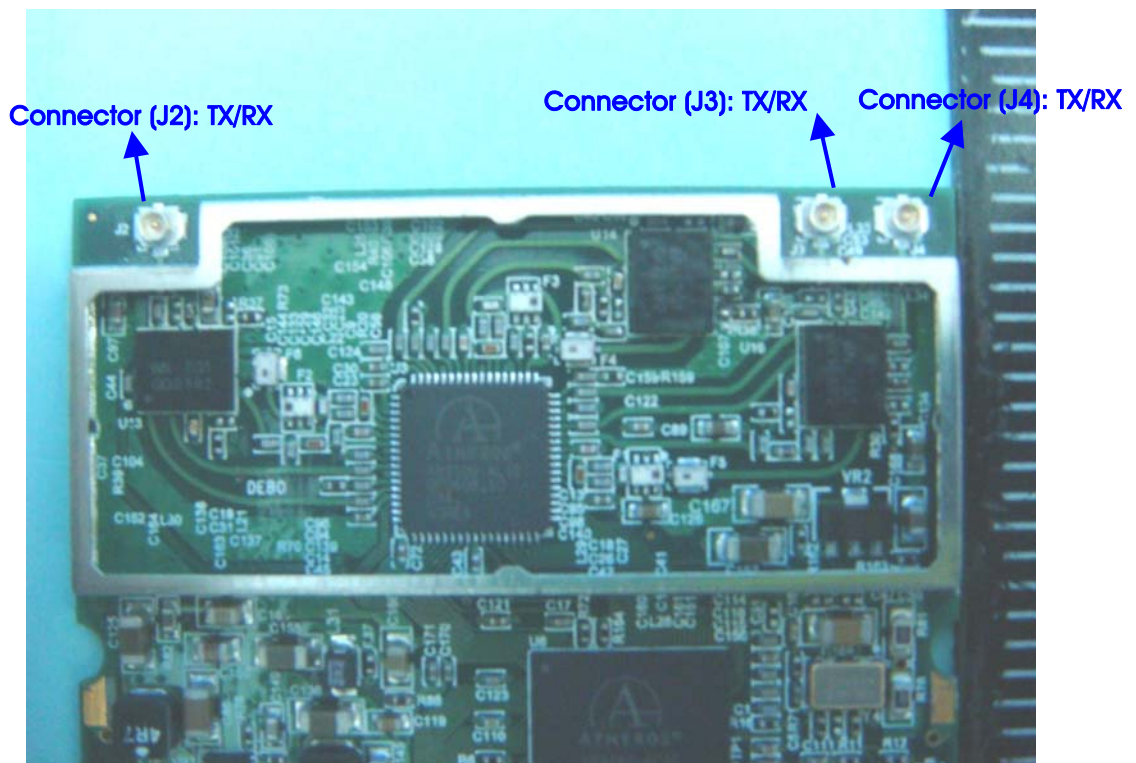

3.4. Table for Carrier Frequencies

Frequency Band	Channel No.	Frequency	Channel No.	Frequency
5150~5250 MHz Band 1	36	5180 MHz	44	5220 MHz
	40	5200 MHz	48	5240 MHz
5250~5350 MHz Band 2	52	5260 MHz	60	5300 MHz
	56	5280 MHz	64	5320 MHz
5470~5725 MHz Band 3	100	5500 MHz	124	5620 MHz
	104	5520 MHz	128	5640 MHz
	108	5540 MHz	132	5660 MHz
	112	5560 MHz	136	5680 MHz
	116	5580 MHz	140	5700 MHz
	120	5600 MHz		

3.5. Table for Test Modes

Preliminary tests were performed in different data rate to find the worst radiated emission. The data rate shown in the table below is the worst-case rate with respect to the specific test item. Investigation has been done on all the possible configurations for searching the worst cases. The following table is a list of the test modes shown in this test report.

Test Items	Mode	Data Rate	Channel	Antenna
AC Power Conducted Emission	Normal Link	Auto	-	1, 5, 6, 7
Max. Conducted Output Power	Band 1/BPSK	6Mbps	36/40/48	1, 5, 6, 7
	Band 2/BPSK	6Mbps	52/60/64	1, 5, 6, 7
	Band 3/BPSK	6Mbps	100/116/140	1, 5, 6, 7
26dB Spectrum Bandwidth 99% Occupied Bandwidth Measurement Power Spectral Density Peak Excursion	Band 1/BPSK	6Mbps	36/40/48	1, 5, 6, 7
	Band 2/BPSK	6Mbps	52/60/64	1, 5, 6, 7
	Band 3/BPSK	6Mbps	100/116/140	1, 5, 6, 7
Radiated Emission Below 1GHz	BPSK	6Mbps	64	1, 5, 6, 7
Radiated Emission Above 1GHz	Band 1/BPSK	6Mbps	36/40/48	1, 5, 6, 7
	Band 2/BPSK	6Mbps	52/60/64	1, 5, 6, 7
	Band 3/BPSK	6Mbps	100/116/140	1, 5, 6, 7
Band Edge Emission	Band 1/BPSK	6Mbps	36/40/48	1, 5, 6, 7
	Band 2/BPSK	6Mbps	52/60/64	1, 5, 6, 7
	Band 3/BPSK	6Mbps	100/140	1, 5, 6, 7
Frequency Stability	Un-modulation	-	38/46	1, 5, 6, 7

3.6. Table for Testing Locations

Test Site No.	Site Category	Location	FCC Reg. No.	IC File No.	VCCI Reg. No
03CH03-HY	SAC	Hwa Ya	101377	IC 4088	-
CO04-HY	Conduction	Hwa Ya	101377	IC 4088	-
TH01-HY	OVEN Room	Hwa Ya	-	-	-

Open Area Test Site (OATS); Semi Anechoic Chamber (SAC); Fully Anechoic Chamber (FAC).

Please refer section 6 for Test Site Address.

3.7. Table for Multiple Listing & Class II Change

This product is an extension of original one reported under Sporton project number: 821502.

Additional, DFS function testing and evaluation for 5250-5350MHz / 5470-5725MHz MHz band.

3.8. Table for Supporting Units

Support Unit	Brand	Model	FCC ID
Notebook	DELL	D400	E2K24GBRL
Notebook	DELL	D505	E2K24GBRL
Modem	ACEEX	DM1414	IFAXDM1414
Mouse	QSKY	Lx-619B	DOC
Printer	EPSON	LQ-300+	DOC

3.9. Table for Parameters of Test Software Setting

During testing, Channel & Power Controlling Software provided by the customer was used to control the operating channel as well as the output power level. The RF output power selection is for the setting of RF output power expected by the customer and is going to be fixed on the firmware of the final end product.

For Antenna 1

Power Parameters of IEEE 802.11a

Test Software Version	ART								
Frequency	5180 MHz	5260 MHz	5240 MHz	5260 MHz	5300 MHz	5320 MHz	5500 MHz	5580 MHz	5700 MHz
IEEE 802.11a	11.5	11.5	12	18.5	19	15.5	12.5	17.5	13

For Antenna 5

Power Parameters of IEEE 802.11a

Test Software Version	ART								
Frequency	5180 MHz	5260 MHz	5240 MHz	5260 MHz	5300 MHz	5320 MHz	5500 MHz	5580 MHz	5700 MHz
IEEE 802.11a	11.5	11.5	12	18.5	17.5	15	15	17.5	14

For Antenna 6
Power Parameters of IEEE 802.11a

Test Software Version	ART								
Frequency	5180 MHz	5260 MHz	5240 MHz	5260 MHz	5300 MHz	5320 MHz	5500 MHz	5580 MHz	5700 MHz
IEEE 802.11a	4.5	4.5	5	12.5	12	12	10	10	11.5

For Antenna 7
Power Parameters of IEEE 802.11a

Test Software Version	ART								
Frequency	5180 MHz	5260 MHz	5240 MHz	5260 MHz	5300 MHz	5320 MHz	5500 MHz	5580 MHz	5700 MHz
IEEE 802.11a	11.5	11.5	12	18.5	19	15	13.5	17.5	13

An executive program, EMCTEST.EXE under WIN XP, which generates a complete line of continuously repeating " H " pattern was used as the test software.

The program was executed as follows :

- a. Turn on the power of all equipment.
- b. The NB sends " H " messages to the panel, and the panel displays " H " patterns on the screen.
- c. The NB sends " H " messages to the printer, then the printer prints them on the paper.
- d. The NB sends " H " messages to the modem.
- e. Repeat the steps from b to d.

At the same time, "ART" was executed to control the EUT continuously transmit RF signal.

3.10. Test Configurations

3.10.1. Radiation Emissions Test Configuration

Antenna 1

Test configuration: 9kHz ~1GHz

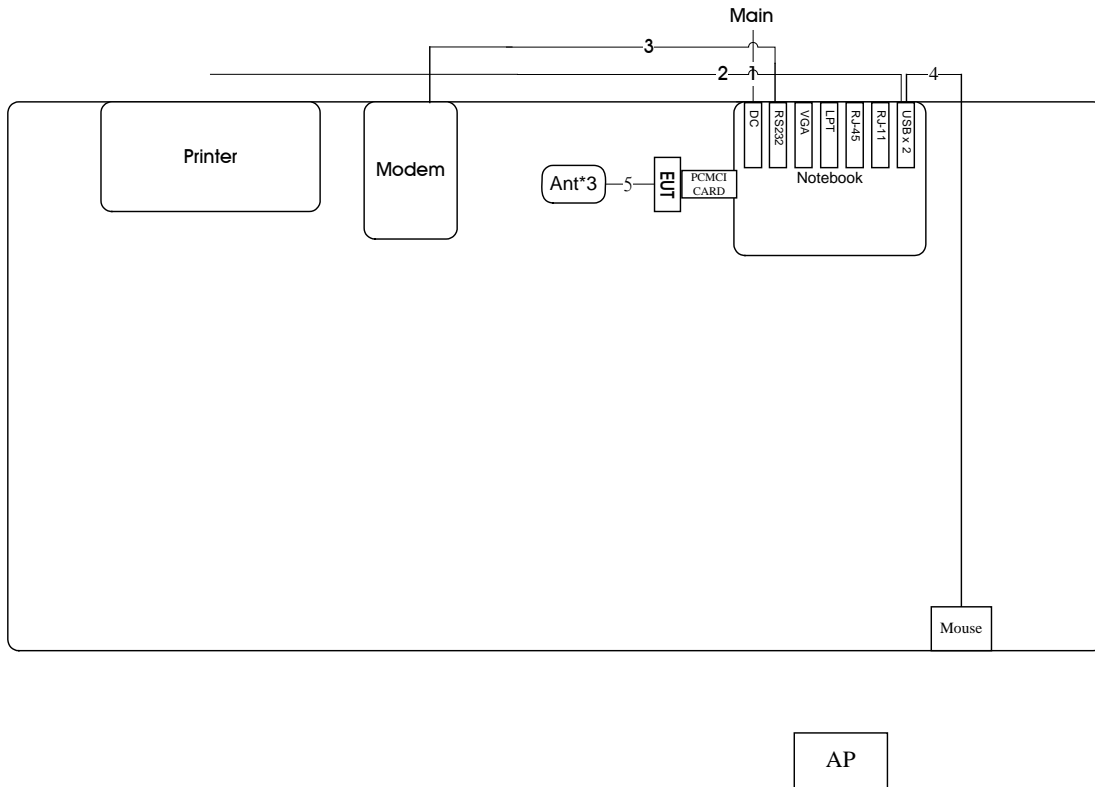

Test configuration: Above 1GHz

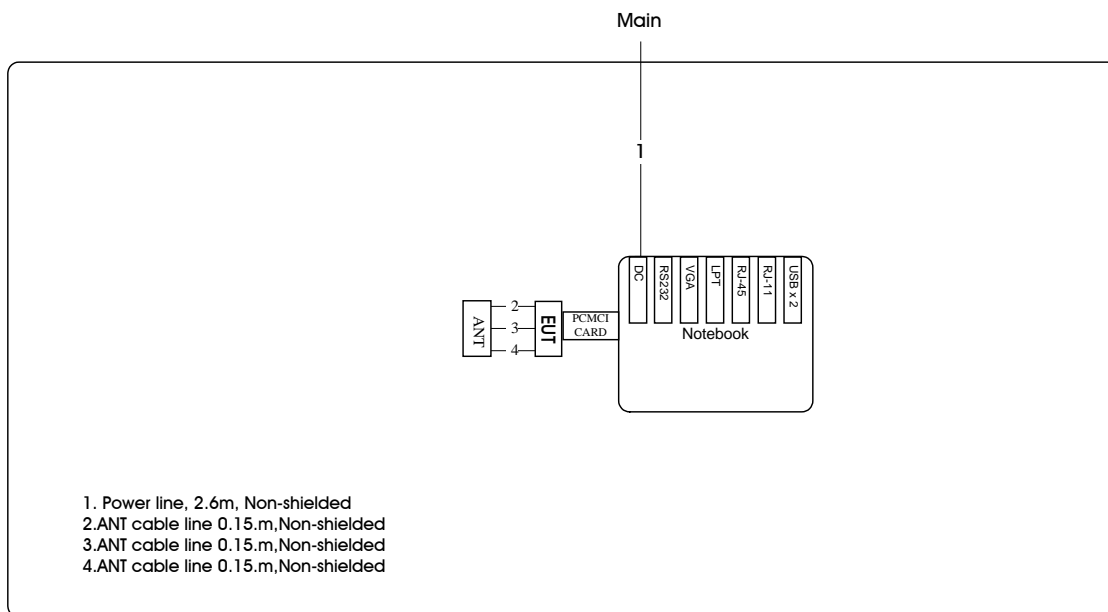

Antenna 5

Test configuration: 9kHz ~1GHz

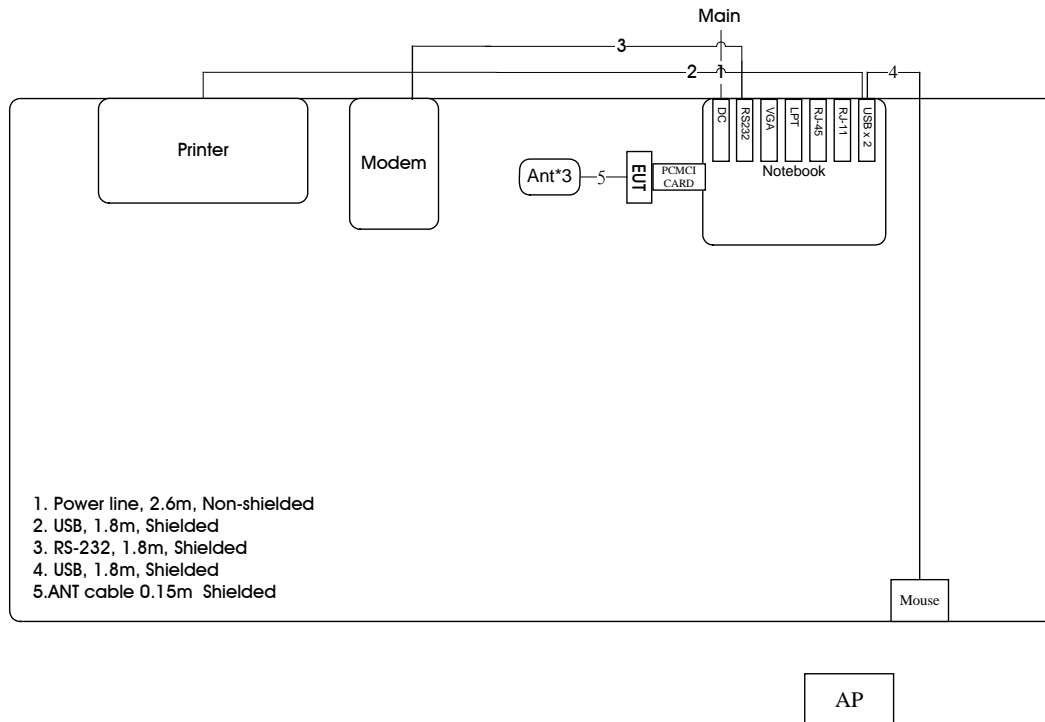

Test configuration: Above 1GHz

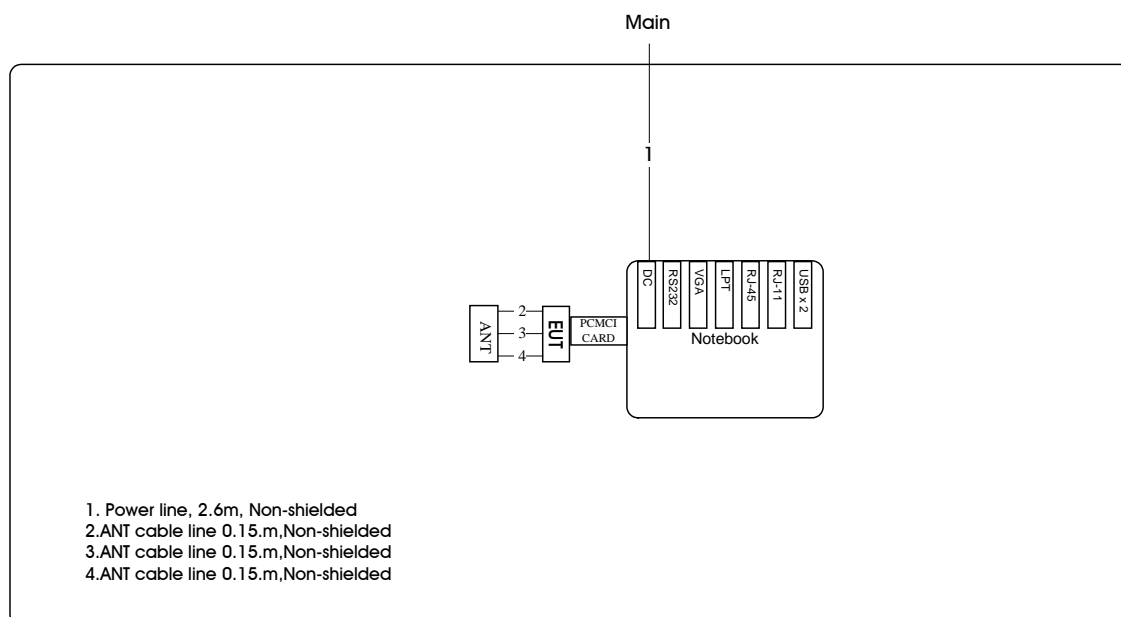

Antenna 6

Test configuration: 9kHz ~1GHz

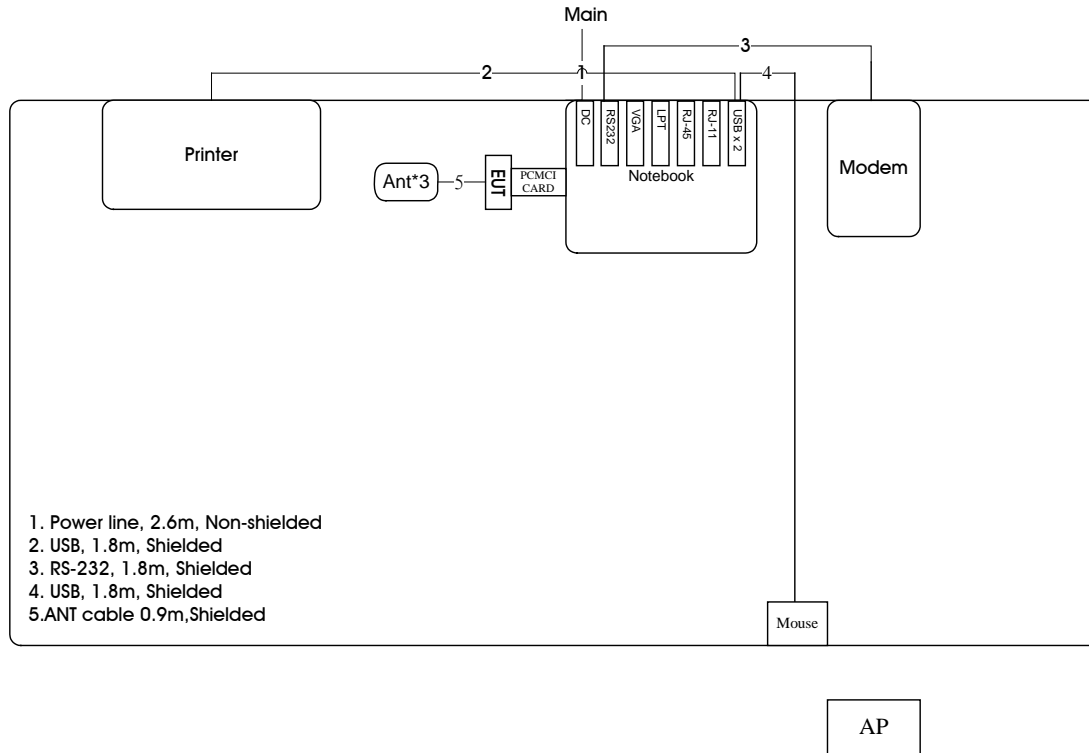

Test configuration: Above 1GHz

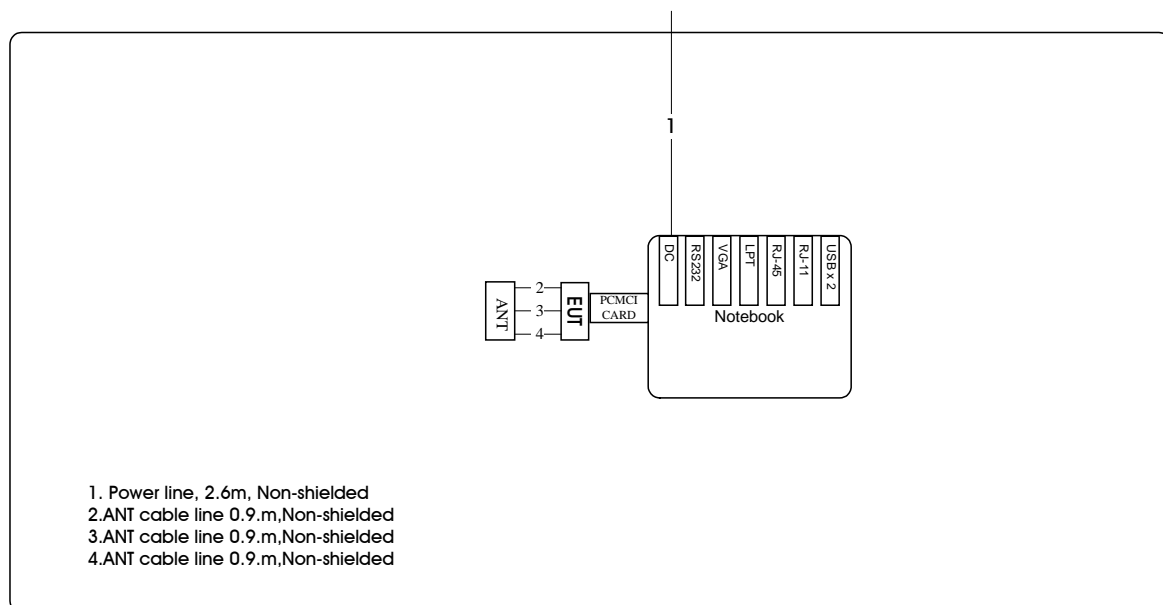

Antenna 7

Test configuration: 9kHz ~1GHz

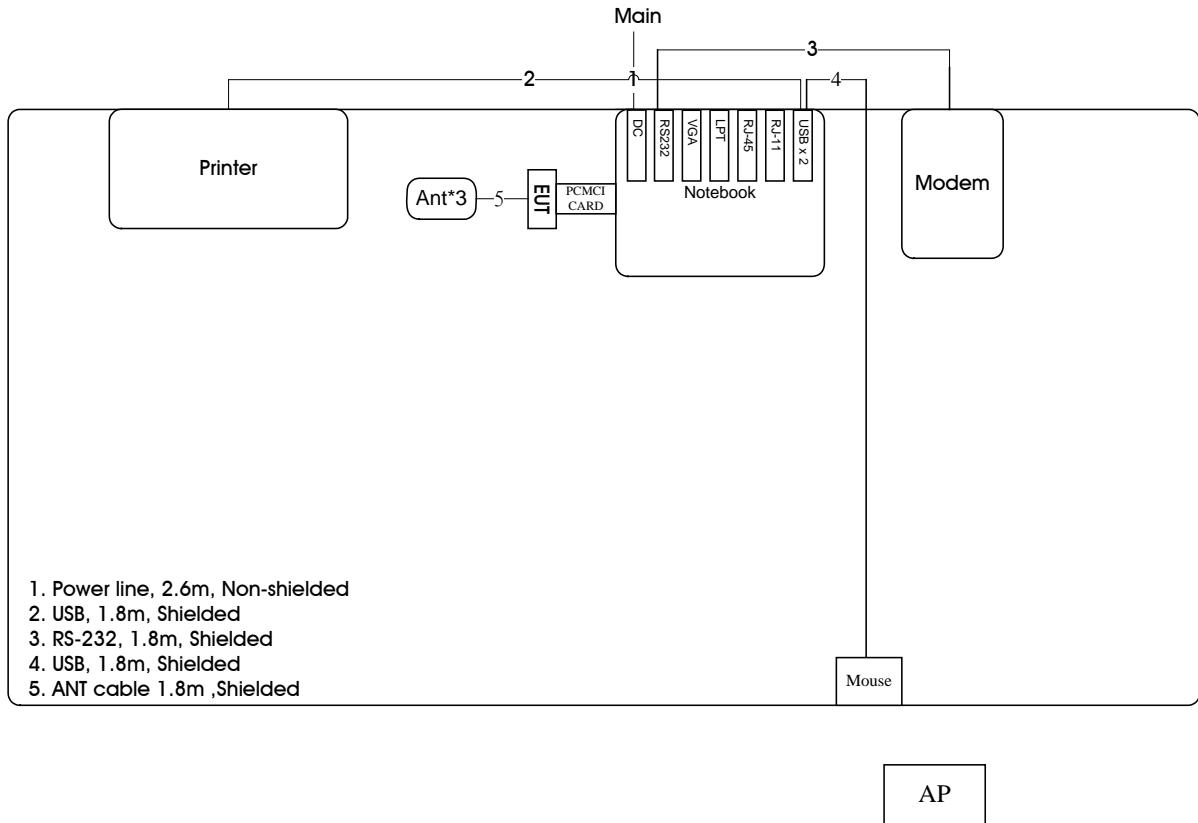

Test configuration: Above 1GHz

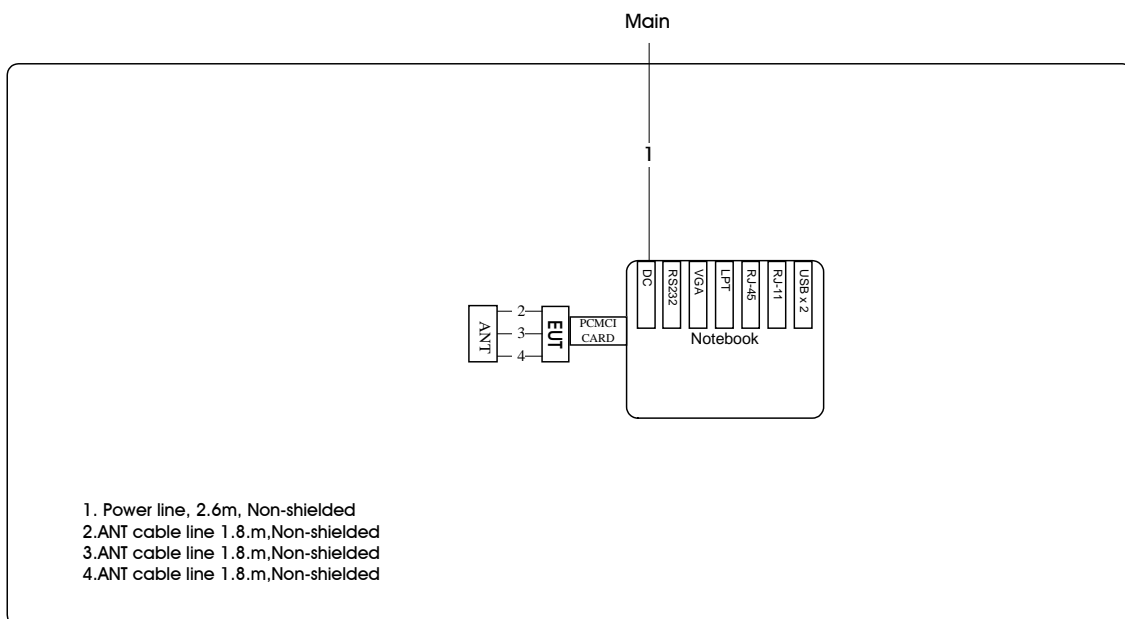

3.10.2. AC Power Line Conduction Emissions Test Configuration

Antenna 1

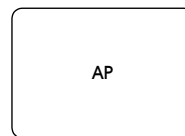
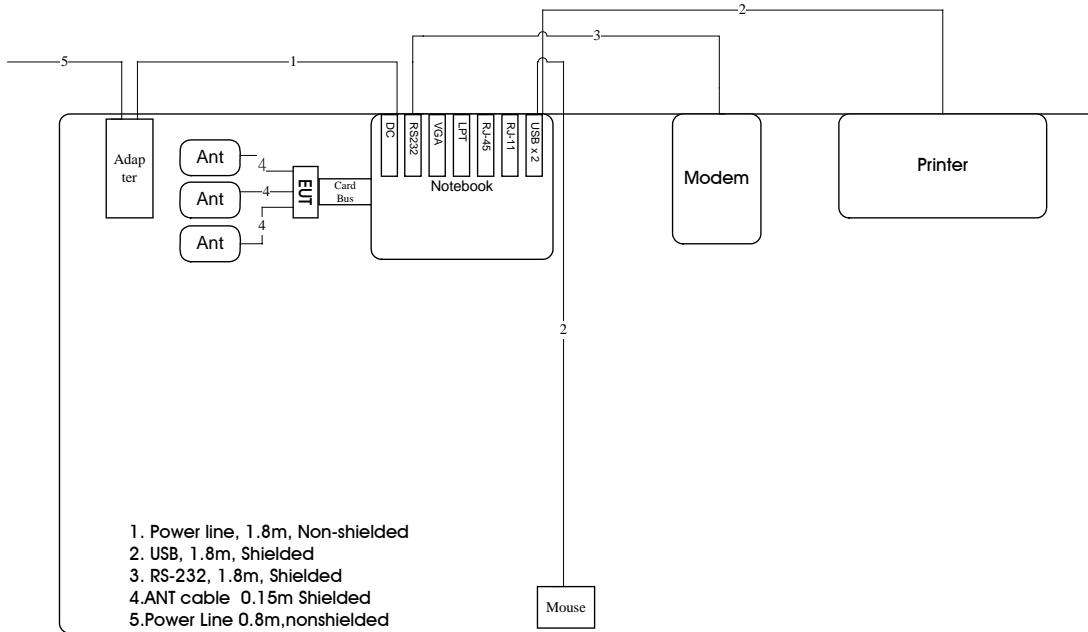

Antenna 5

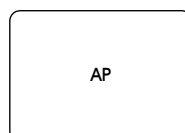
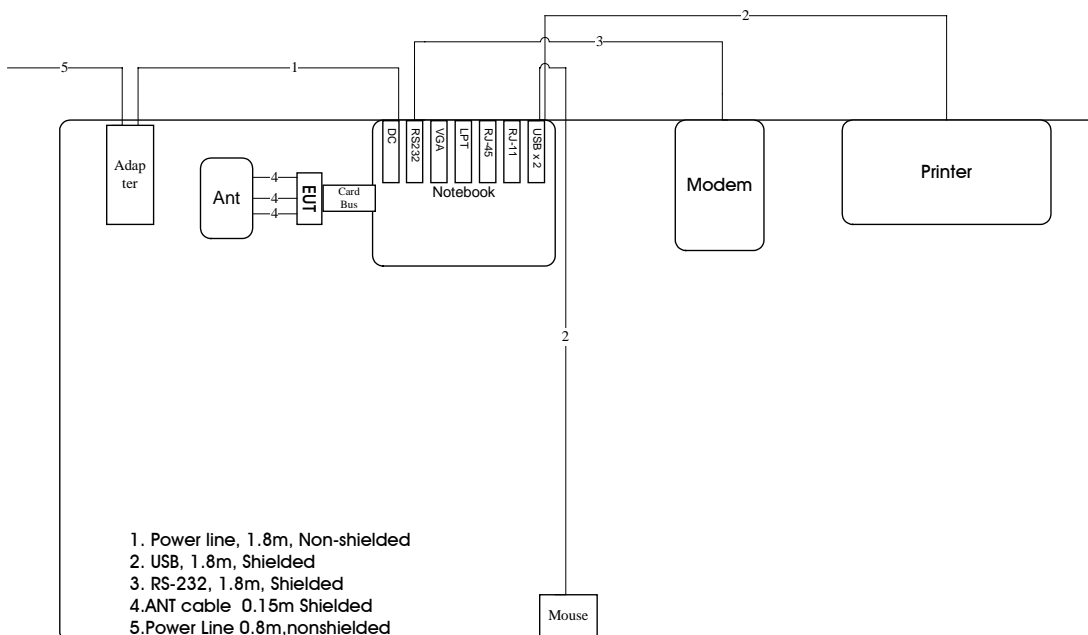

Antenna 6

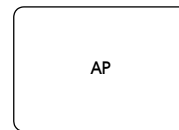
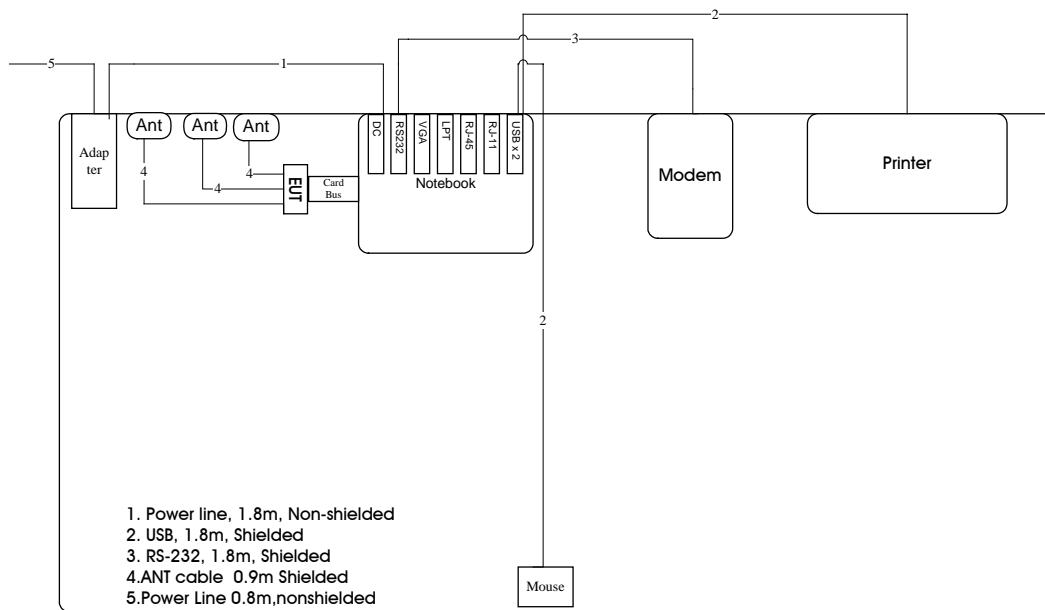

Antenna 7

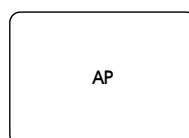
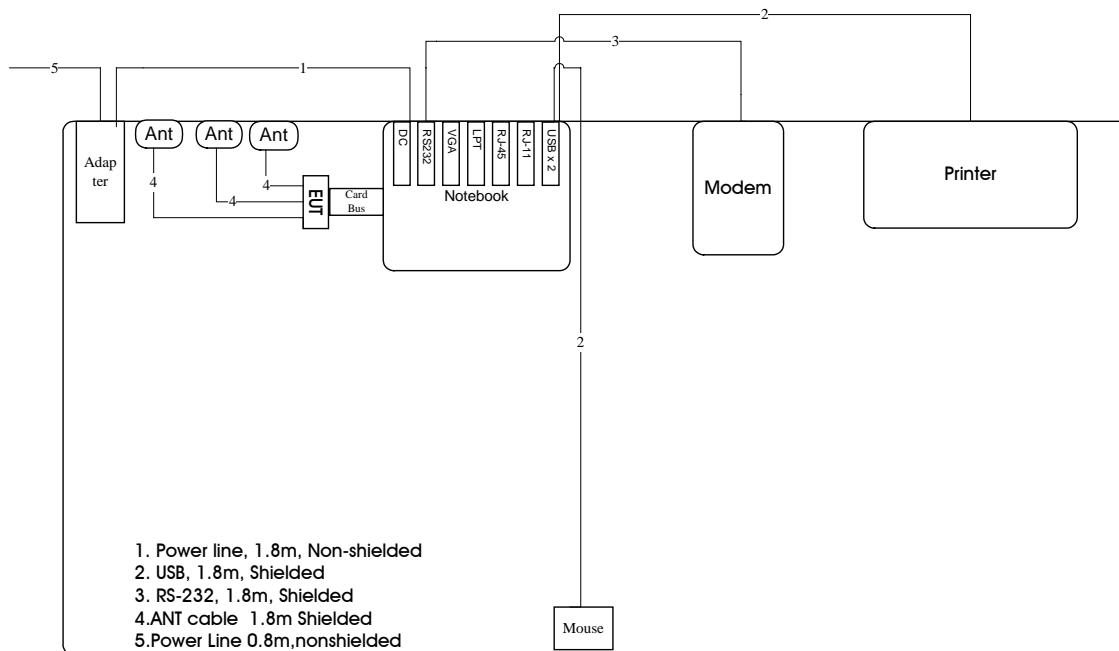

4. TEST RESULT

4.1. AC Power Line Conducted Emissions Measurement

4.1.1. Limit

For this product that is designed to connect to the AC power line, the radio frequency voltage that is conducted back onto the AC power line on any frequency or frequencies within the band 150 kHz to 30 MHz shall not exceed below limits table.

Frequency (MHz)	QP Limit (dBuV)	AV Limit (dBuV)
0.15~0.5	66~56	56~46
0.5~5	56	46
5~30	60	50

4.1.2. Measuring Instruments and Setting

Please refer to section 5 of equipments list in this report. The following table is the setting of the receiver.

Receiver Parameters	Setting
Attenuation	10 dB
Start Frequency	0.15 MHz
Stop Frequency	30 MHz
IF Bandwidth	9 KHz

4.1.3. Test Procedures

1. Configure the EUT according to ANSI C63.4. The EUT or host of EUT has to be placed 0.4 meter far from the conducting wall of the shielding room and at least 80 centimeters from any other grounded conducting surface.
2. Connect EUT or host of EUT to the power mains through a line impedance stabilization network (LISN).
3. All the support units are connected to the other LISNs. The LISN should provide 50uH/50ohms coupling impedance.
4. The frequency range from 150 KHz to 30 MHz was searched.
5. Set the test-receiver system to Peak Detect Function and Specified Bandwidth with Maximum Hold Mode.
6. The measurement has to be done between each power line and ground at the power terminal.

4.1.4. Test Setup Layout

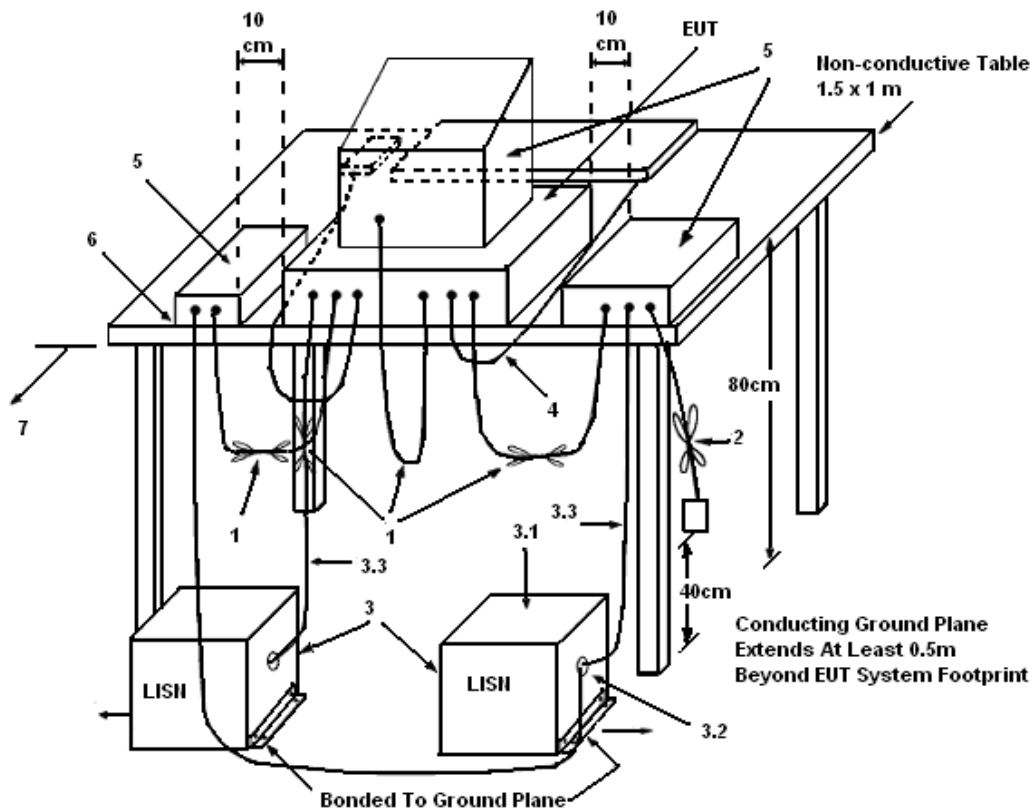

LEGEND:

- (1) Interconnecting cables that hang closer than 40 cm to the ground plane shall be folded back and forth in the center forming a bundle 30 to 40 cm long.
- (2) I/O cables that are not connected to a peripheral shall be bundled in the center. The end of the cable may be terminated, if required, using the correct terminating impedance. The overall length shall not exceed 1 m.
- (3) EUT connected to one LISN. Unused LISN measuring port connectors shall be terminated in 50 Ω. LISN can be placed on top of, or immediately beneath, reference ground plane.
 - (3.1) All other equipment powered from additional LISN(s).
 - (3.2) Multiple outlet strip can be used for multiple power cords of non-EUT equipment.
 - (3.3) LISN at least 80 cm from nearest part of EUT chassis.
- (4) Cables of hand-operated devices, such as keyboards, mice, etc., shall be placed as for normal use.
- (5) Non-EUT components of EUT system being tested.
- (6) Rear of EUT, including peripherals, shall all be aligned and flush with rear of tabletop.
- (7) Rear of tabletop shall be 40 cm removed from a vertical conducting plane that is bonded to the ground plane.

4.1.5. Test Deviation

There is no deviation with the original standard.

4.1.6. EUT Operation during Test

The EUT was placed on the test table and programmed in normal function.

4.1.7. Results of AC Power Line Conducted Emissions Measurement

Temperature	25°C	Humidity	43%
Test Engineer	Cloud Peng	Phase	Line
Configuration	Antenna 1		

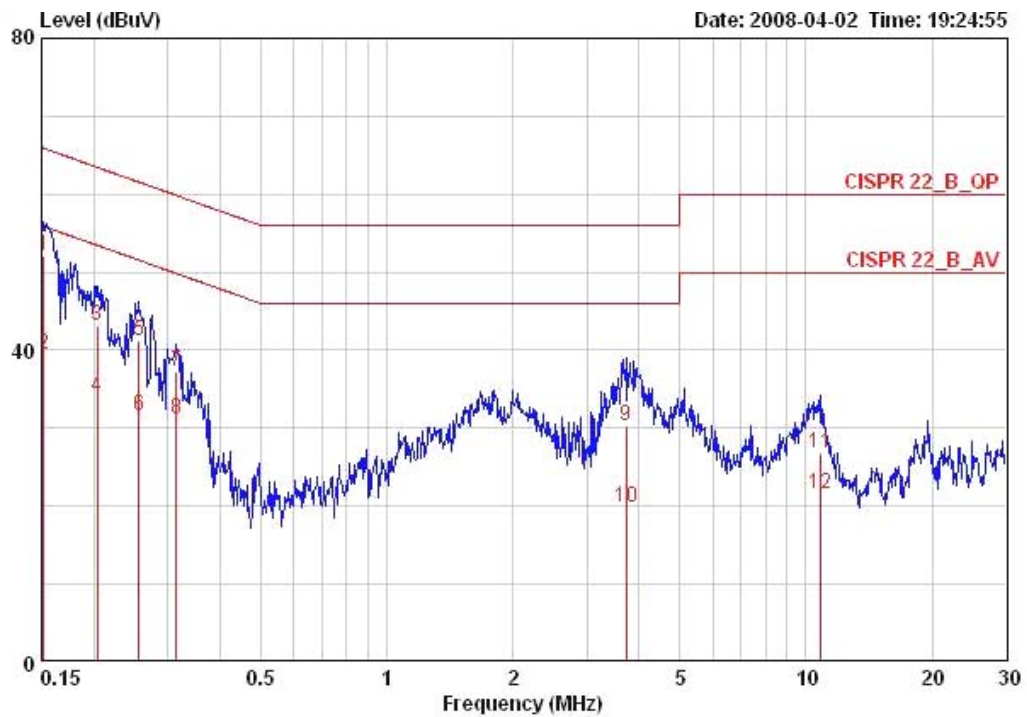

	Freq	Level	Over Limit	Limit Line	Read Level	LISN Factor	Cable Loss	Remark
	MHz	dBµV	dB	dBµV	dBµV	dB	dB	
1	0.15160	52.13	-13.78	65.91	51.73	0.20	0.20	QP
2	0.15160	39.50	-16.41	55.91	39.10	0.20	0.20	AVERAGE
3	0.20396	43.15	-20.30	63.45	42.85	0.10	0.20	QP
4	0.20396	33.91	-19.54	53.45	33.61	0.10	0.20	AVERAGE
5	0.25615	41.14	-20.42	61.56	40.84	0.10	0.20	QP
6	0.25615	31.69	-19.87	51.56	31.39	0.10	0.20	AVERAGE
7	0.31495	37.28	-22.56	59.84	36.98	0.10	0.20	QP
8	0.31495	31.09	-18.75	49.84	30.79	0.10	0.20	AVERAGE
9	3.720	30.26	-25.74	56.00	29.96	0.00	0.30	QP
10	3.720	19.94	-26.06	46.00	19.64	0.00	0.30	AVERAGE
11	10.847	26.82	-33.18	60.00	26.32	0.10	0.40	QP
12	10.847	21.61	-28.39	50.00	21.11	0.10	0.40	AVERAGE

Temperature	25°C	Humidity	43%
Test Engineer	Cloud Peng	Phase	Neutral
Configuration	Antenna 1		

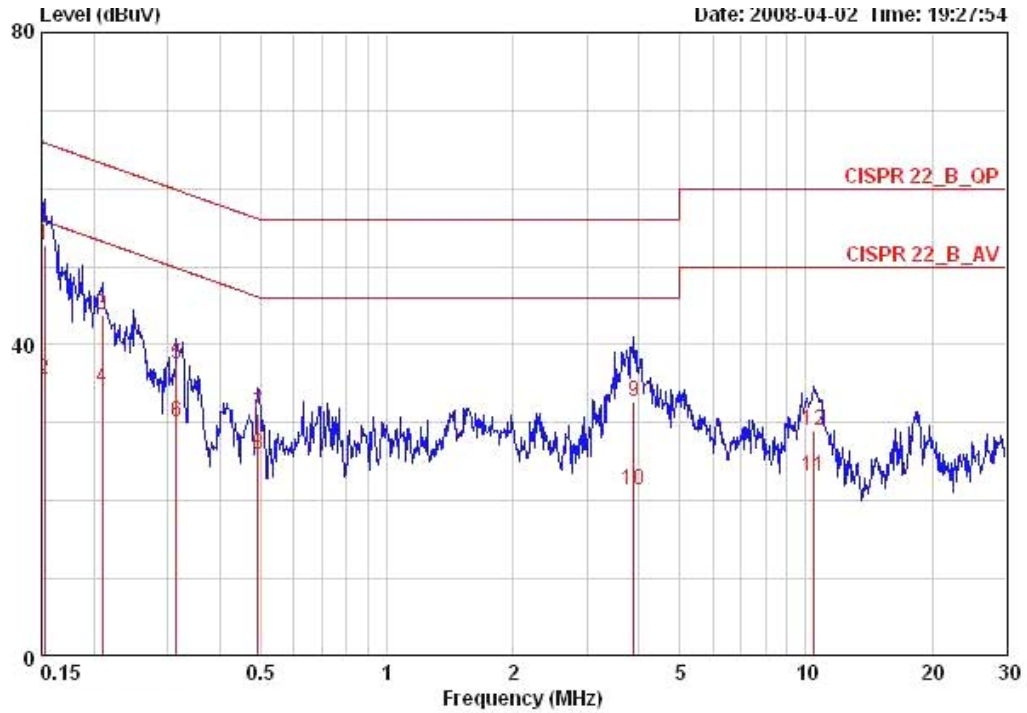

	Freq	Level	Over Limit	Limit Line	Read Level	LISN Factor	Cable Loss	Remark
	MHz	dBuV	dB	dBuV	dBuV	dB	dB	
1	0.15240	52.77	-13.10	65.87	52.27	0.30	0.20	QP
2	0.15240	35.45	-20.42	55.87	34.95	0.30	0.20	AVERAGE
3	0.20944	43.71	-19.52	63.23	43.31	0.20	0.20	QP
4	0.20944	34.46	-18.77	53.23	34.06	0.20	0.20	AVERAGE
5	0.31495	37.45	-22.39	59.84	37.12	0.13	0.20	QP
6	0.31495	30.13	-19.71	49.84	29.80	0.13	0.20	AVERAGE
7	0.49150	31.09	-25.06	56.14	30.86	0.10	0.13	QP
8	0.49150	25.87	-20.28	46.14	25.64	0.10	0.13	AVERAGE
9	3.881	32.69	-23.31	56.00	32.29	0.10	0.30	QP
10	3.881	21.32	-24.68	46.00	20.92	0.10	0.30	AVERAGE
11	10.397	23.08	-26.92	50.00	22.60	0.10	0.38	AVERAGE
12	10.397	29.10	-30.90	60.00	28.62	0.10	0.38	QP

Note:

Level = Read Level + LISN Factor + Cable Loss.

Temperature	25°C	Humidity	43%
Test Engineer	Cloud Peng	Phase	Line
Configuration	Antenna 5		

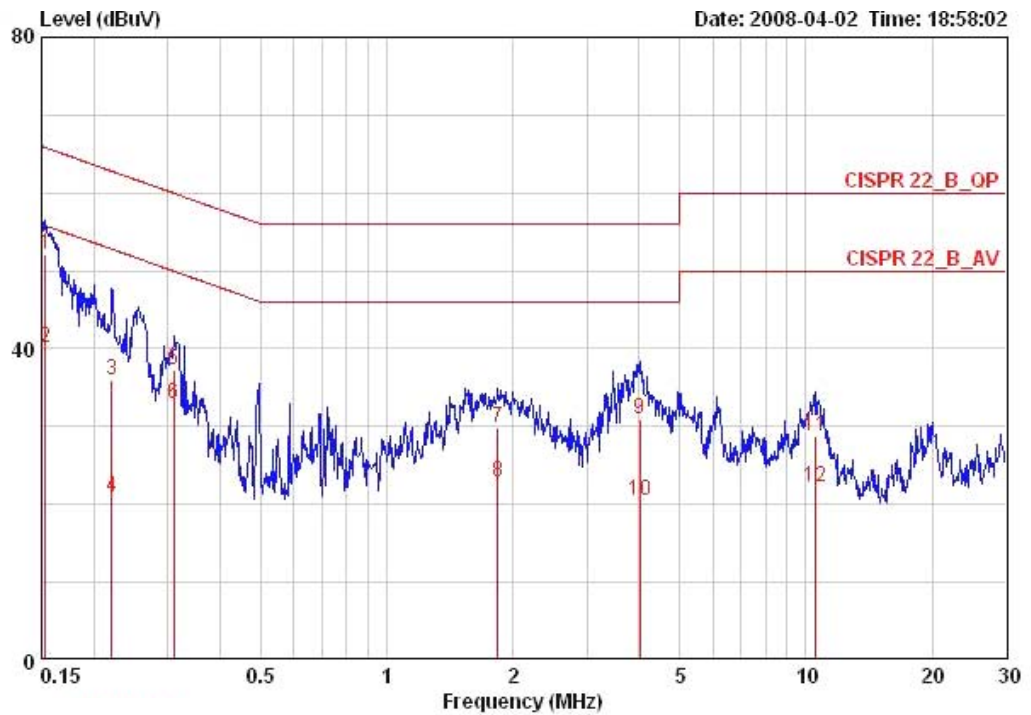

	Freq	Level	Over	Limit	Read	LISN	Cable	Remark
	MHz	dBuV	Limit	Line	Level	Factor	Loss	
			dB	dBuV	dBuV	dB	dB	
1	0.15321	52.12	-13.70	65.82	51.72	0.20	0.20	QP
2	0.15321	40.19	-15.63	55.82	39.79	0.20	0.20	AVERAGE
3	0.22083	36.04	-26.75	62.79	35.74	0.10	0.20	QP
4	0.22083	20.88	-31.91	52.79	20.58	0.10	0.20	AVERAGE
5	0.30998	37.25	-22.72	59.97	36.95	0.10	0.20	QP
6	0.30998	32.90	-17.07	49.97	32.60	0.10	0.20	AVERAGE
7	1.839	29.86	-26.14	56.00	29.69	0.00	0.17	QP
8	1.839	22.96	-23.04	46.00	22.79	0.00	0.17	AVERAGE
9	4.006	30.90	-25.10	56.00	30.60	0.00	0.30	QP
10	4.006	20.40	-25.60	46.00	20.10	0.00	0.30	AVERAGE
11	10.564	28.67	-31.33	60.00	28.17	0.10	0.40	QP
12	10.564	22.30	-27.70	50.00	21.80	0.10	0.40	AVERAGE

Temperature	25°C	Humidity	43%
Test Engineer	Cloud Peng	Phase	Neutral
Configuration	Antenna 5		

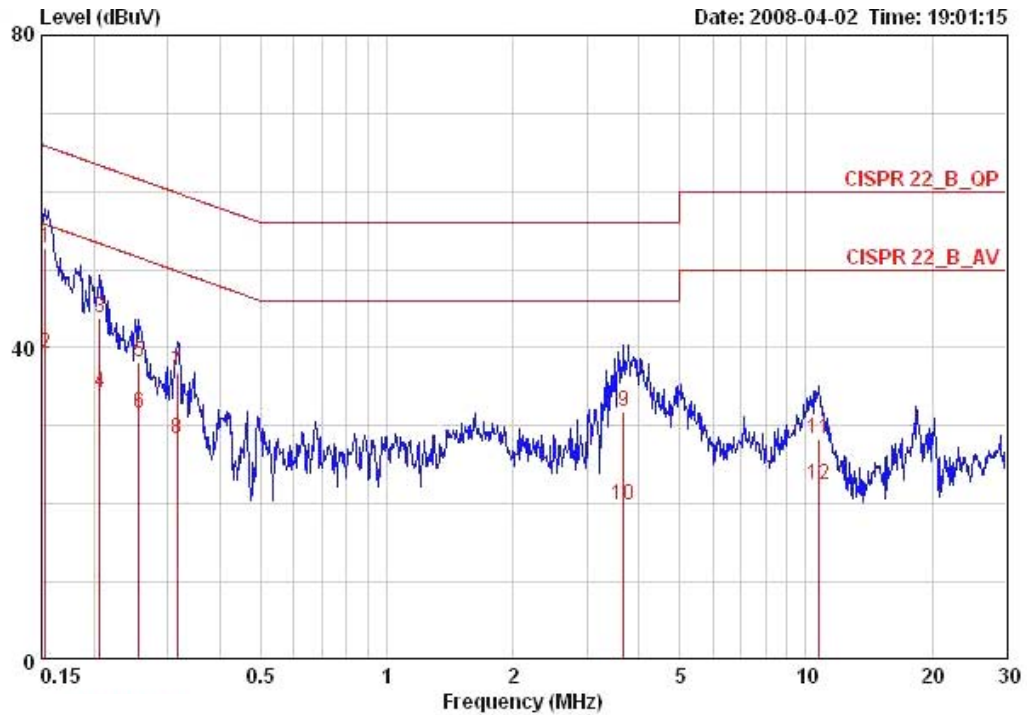

	Freq	Level	Over Limit	Limit Line	Read Level	LISN Factor	Cable Loss	Remark
	MHz	dBuV	dB	dBuV	dBuV	dB	dB	
1	0.15321	52.82	-13.00	65.82	52.32	0.30	0.20	QP
2	0.15321	39.24	-16.58	55.82	38.74	0.30	0.20	AVERAGE
3	0.20614	43.81	-19.55	63.36	43.41	0.20	0.20	QP
4	0.20614	34.31	-19.05	53.36	33.91	0.20	0.20	AVERAGE
5	0.25615	38.12	-23.44	61.56	37.75	0.17	0.20	QP
6	0.25615	31.71	-19.85	51.56	31.34	0.17	0.20	AVERAGE
7	0.31662	36.74	-23.05	59.80	36.41	0.13	0.20	QP
8	0.31662	28.37	-21.42	49.80	28.04	0.13	0.20	AVERAGE
9	3.681	31.77	-24.23	56.00	31.37	0.10	0.30	QP
10	3.681	19.89	-26.11	46.00	19.49	0.10	0.30	AVERAGE
11	10.733	28.23	-31.77	60.00	27.73	0.10	0.40	QP
12	10.733	22.45	-27.55	50.00	21.95	0.10	0.40	AVERAGE

Note:

Level = Read Level + LISN Factor + Cable Loss.

Temperature	25°C	Humidity	43%
Test Engineer	Cloud Peng	Phase	Line
Configuration	Antenna 6		

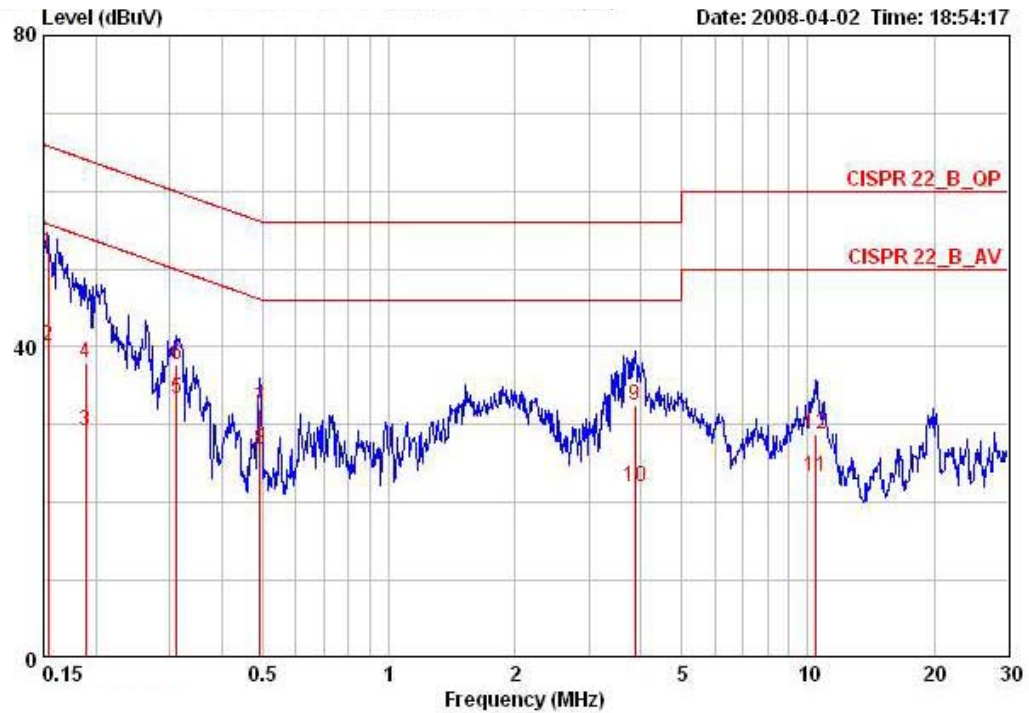

	Freq	Level	Over	Limit	Read	LISN	Cable	Remark
	MHz	dBuV	Limit	Line	Level	Factor	Loss	
			dB	dBuV	dBuV	dB	dB	
1	0.15403	52.10	-13.68	65.78	51.70	0.20	0.20	QP
2	0.15403	40.19	-15.59	55.78	39.79	0.20	0.20	AVERAGE
3	0.18938	29.12	-24.94	54.06	28.77	0.15	0.20	AVERAGE
4	0.18938	37.97	-26.09	64.06	37.62	0.15	0.20	QP
5	0.31163	33.42	-16.51	49.93	33.12	0.10	0.20	AVERAGE
6	0.31163	37.74	-22.19	59.93	37.44	0.10	0.20	QP
7	0.49150	31.94	-24.20	56.14	31.73	0.09	0.13	QP
8	0.49150	26.78	-19.36	46.14	26.57	0.09	0.13	AVERAGE
9	3.860	32.46	-23.54	56.00	32.16	0.00	0.30	QP
10	3.860	21.96	-24.04	46.00	21.66	0.00	0.30	AVERAGE
11	10.397	23.25	-26.75	50.00	22.77	0.10	0.38	AVERAGE
12	10.397	28.88	-31.12	60.00	28.40	0.10	0.38	QP

Temperature	25°C	Humidity	43%
Test Engineer	Cloud Peng	Phase	Neutral
Configuration	Antenna 6		

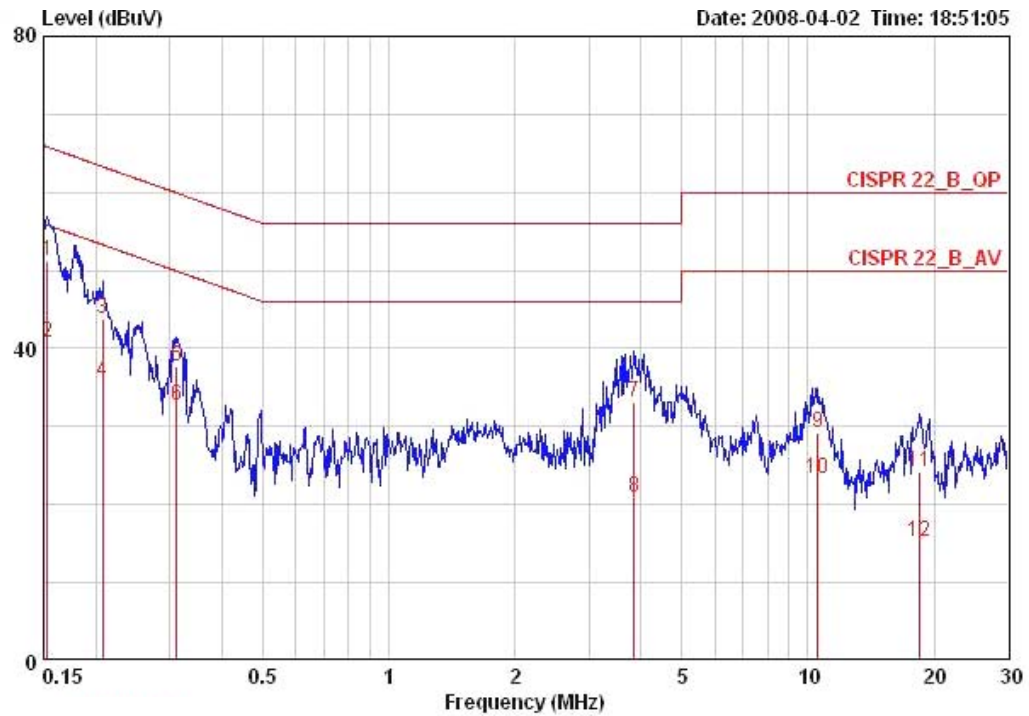

	Freq	Level	Over Limit	Limit Line	Read Level	LISN Factor	Cable Loss	Remark
	MHz	dBuV	dB	dBuV	dBuV	dB	dB	
1	0.15321	51.27	-14.55	65.82	50.77	0.30	0.20	QP
2	0.15321	40.82	-15.00	55.82	40.32	0.30	0.20	AVERAGE
3	0.20723	43.81	-19.51	63.32	43.41	0.20	0.20	QP
4	0.20723	35.82	-17.50	53.32	35.42	0.20	0.20	AVERAGE
5	0.31163	37.73	-22.20	59.93	37.38	0.15	0.20	QP
6	0.31163	32.77	-17.16	49.93	32.42	0.15	0.20	AVERAGE
7	3.840	33.09	-22.91	56.00	32.69	0.10	0.30	QP
8	3.840	20.99	-25.01	46.00	20.59	0.10	0.30	AVERAGE
9	10.564	29.27	-30.73	60.00	28.77	0.10	0.40	QP
10	10.564	23.28	-26.72	50.00	22.78	0.10	0.40	AVERAGE
11	18.524	24.20	-35.80	60.00	23.60	0.10	0.50	QP
12	18.524	15.31	-34.69	50.00	14.71	0.10	0.50	AVERAGE

Note:

Level = Read Level + LISN Factor + Cable Loss.

Temperature	25°C	Humidity	43%
Test Engineer	Cloud Peng	Phase	Line
Configuration	Antenna 7		

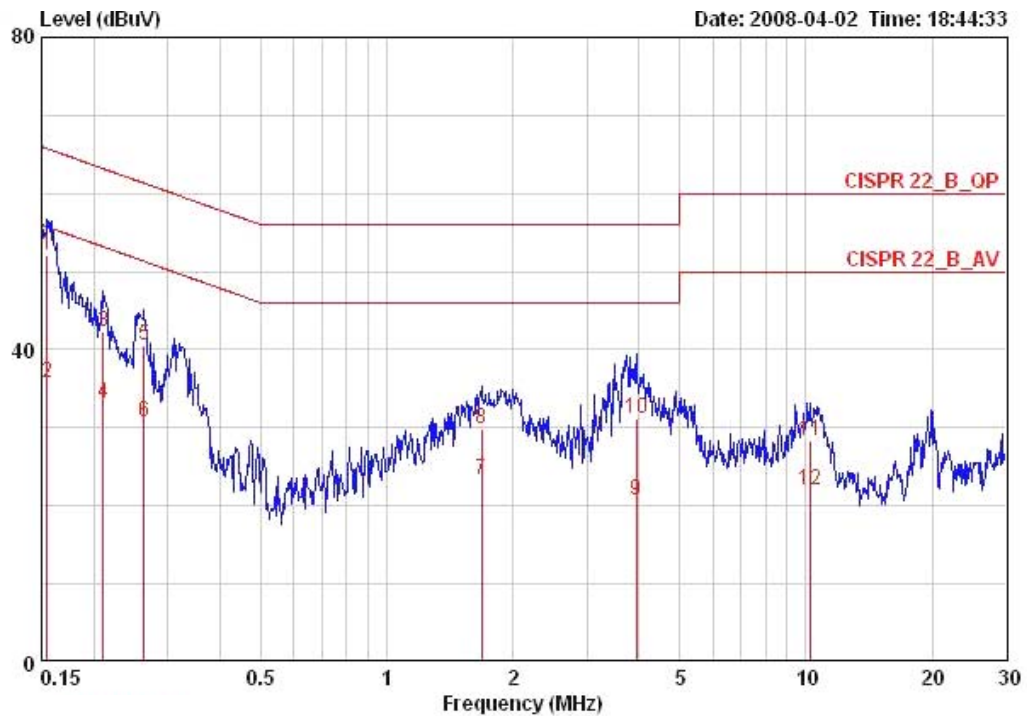

	Freq	Level	Over	Limit	Read	LISN	Cable	Remark
	MHz	dBuV	Limit	Line	Level	Factor	Loss	
			dB	dBuV	dBuV	dB	dB	
1	0.15485	52.18	-13.56	65.74	51.78	0.20	0.20	QP
2	0.15485	35.66	-20.08	55.74	35.26	0.20	0.20	AVERAGE
3	0.21055	42.30	-20.88	63.18	42.00	0.10	0.20	QP
4	0.21055	33.05	-20.13	53.18	32.75	0.10	0.20	AVERAGE
5	0.26303	40.46	-20.88	61.34	40.16	0.10	0.20	QP
6	0.26303	30.64	-20.70	51.34	30.34	0.10	0.20	AVERAGE
7	1.680	23.33	-22.67	46.00	23.19	0.00	0.14	AVERAGE
8	1.680	29.93	-26.07	56.00	29.79	0.00	0.14	QP
9	3.943	20.76	-25.24	46.00	20.46	0.00	0.30	AVERAGE
10	3.943	31.19	-24.81	56.00	30.89	0.00	0.30	QP
11	10.233	28.23	-31.77	60.00	27.79	0.10	0.34	QP
12	10.233	22.02	-27.98	50.00	21.58	0.10	0.34	AVERAGE

Temperature	25°C	Humidity	43%
Test Engineer	Cloud Peng	Phase	Neutral
Configuration	Antenna 7		

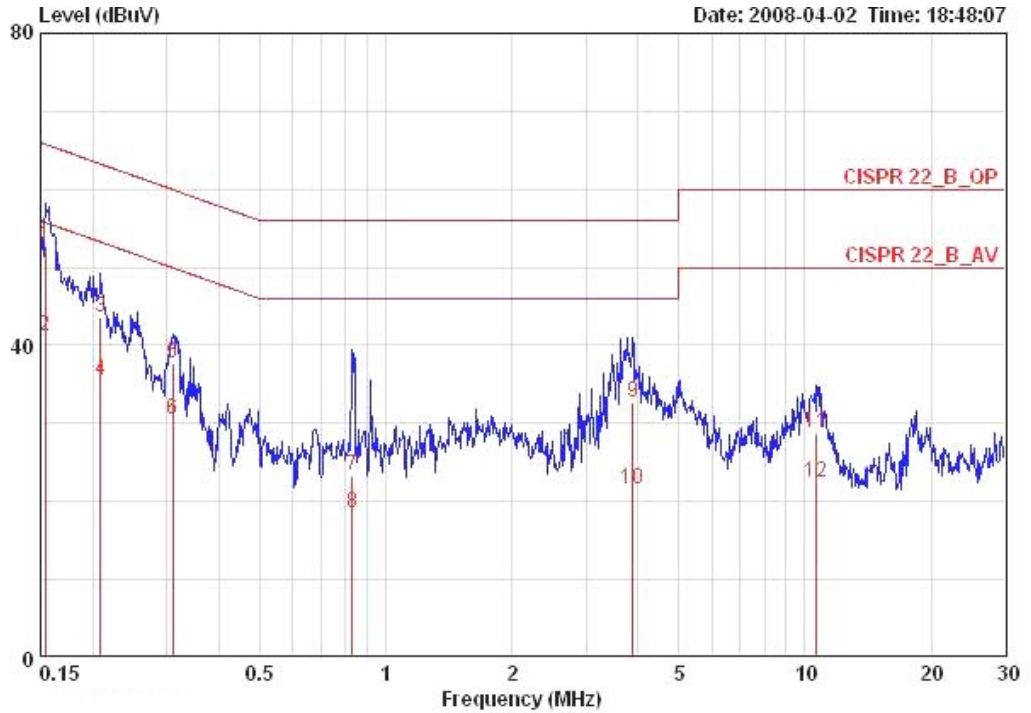

	Freq	Level	Over	Limit	Read	LISN	Cable	Remark
	MHz	dBuV	Limit	Line	Level	Factor	Loss	
			dB	dBuV	dBuV	dB	dB	
1	0.15403	52.72	-13.06	65.78	52.22	0.30	0.20	QP
2	0.15403	41.17	-14.61	55.78	40.67	0.30	0.20	AVERAGE
3	0.20833	43.59	-19.68	63.27	43.19	0.20	0.20	QP
4	0.20833	35.61	-17.66	53.27	35.21	0.20	0.20	AVERAGE
5	0.30998	37.64	-22.33	59.97	37.29	0.15	0.20	QP
6	0.30998	30.54	-19.43	49.97	30.19	0.15	0.20	AVERAGE
7	0.83047	23.42	-32.58	56.00	23.12	0.10	0.20	QP
8	0.83047	18.61	-27.39	46.00	18.31	0.10	0.20	AVERAGE
9	3.881	32.63	-23.37	56.00	32.23	0.10	0.30	QP
10	3.881	21.58	-24.42	46.00	21.18	0.10	0.30	AVERAGE
11	10.676	28.88	-31.12	60.00	28.38	0.10	0.40	QP
12	10.676	22.49	-27.51	50.00	21.99	0.10	0.40	AVERAGE

Note:

Level = Read Level + LISN Factor + Cable Loss.

4.2. 99% Occupied Bandwidth Measurement

4.2.1. Limit

No restriction limits. But resolution bandwidth within band edge measurement is 1% of the 99% occupied bandwidth.

4.2.2. Measuring Instruments and Setting

Please refer to section 5 of equipments list in this report. The following table is the setting of the spectrum analyzer.

Spectrum Parameters	Setting
Attenuation	Auto
Span Frequency	> 26dB Bandwidth
RB	3000 kHz
VB	1000 kHz
Detector	RMS
Trace	Max Hold
Sweep Time	Auto

4.2.3. Test Procedures

1. The transmitter output (antenna port) was connected to the spectrum analyzer in peak hold mode.
2. The resolution bandwidth of 300 kHz and the video bandwidth of 1000 kHz were used.
3. Measured the spectrum width with power higher than 26dB below carrier.
4. Measuring multiple antennas, the connector is required to link with spectrum analyzer through a combiner.

4.2.4. Test Setup Layout

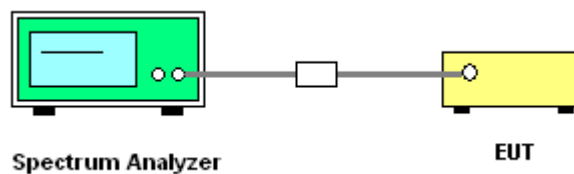

4.2.5. Test Deviation

There is no deviation with the original standard.

4.2.6. EUT Operation during Test

The EUT was programmed to be in continuously transmitting mode.

4.2.7. Test Result of 99% Occupied Bandwidth

Temperature	22°C	Humidity	61%
Test Engineer	Sam Chen	Configurations	802.11a / Antenna 1

Configuration IEEE 802.11a Ant. 1

Channel	Frequency	26dB Bandwidth (MHz)	99% Occupied Bandwidth (MHz)
36	5180 MHz	22.94	17.94
40	5260 MHz	23.07	17.94
48	5240 MHz	22.56	17.94
52	5260 MHz	23.33	17.94
60	5300 MHz	23.58	17.94
64	5320 MHz	22.30	17.94
100	5500 MHz	22.05	16.79
116	5580 MHz	32.82	17.82
140	5700 MHz	21.60	16.79

Temperature	22°C	Humidity	61%
Test Engineer	Sam Chen	Configurations	802.11a / Antenna 5

Configuration IEEE 802.11a Ant. 5

Channel	Frequency	26dB Bandwidth (MHz)	99% Occupied Bandwidth (MHz)
36	5180 MHz	22.94	17.94
40	5260 MHz	23.07	17.94
48	5240 MHz	22.56	17.94
52	5260 MHz	23.33	17.94
60	5300 MHz	22.17	16.79
64	5320 MHz	22.17	16.66
100	5500 MHz	22.30	16.66
116	5580 MHz	32.82	17.82
140	5700 MHz	22.30	16.92

Temperature	22°C	Humidity	61%
Test Engineer	Sam Chen	Configurations	802.11a / Antenna 6

Configuration IEEE 802.11a Ant. 6

Channel	Frequency	26dB Bandwidth (MHz)	99% Occupied Bandwidth (MHz)
36	5180 MHz	22.43	16.79
40	5260 MHz	21.66	16.66
48	5240 MHz	22.05	16.92
52	5260 MHz	22.17	16.79
60	5300 MHz	21.92	16.79
64	5320 MHz	21.66	16.92
100	5500 MHz	21.66	16.66
116	5580 MHz	21.79	16.66
140	5700 MHz	21.66	16.92

Temperature	22°C	Humidity	61%
Test Engineer	Sam Chen	Configurations	802.11a / Antenna 7

Configuration IEEE 802.11a Ant. 7

Channel	Frequency	26dB Bandwidth (MHz)	99% Occupied Bandwidth (MHz)
36	5180 MHz	22.94	17.94
40	5260 MHz	23.07	17.94
48	5240 MHz	22.56	17.94
52	5260 MHz	23.33	17.94
60	5300 MHz	23.58	17.94
64	5320 MHz	22.17	16.66
100	5500 MHz	22.30	16.92
116	5580 MHz	32.82	17.82
140	5700 MHz	21.60	16.79

26 dB Bandwidth Plot on Configuration IEEE 802.11a Ant. 1 / 5180 MHz

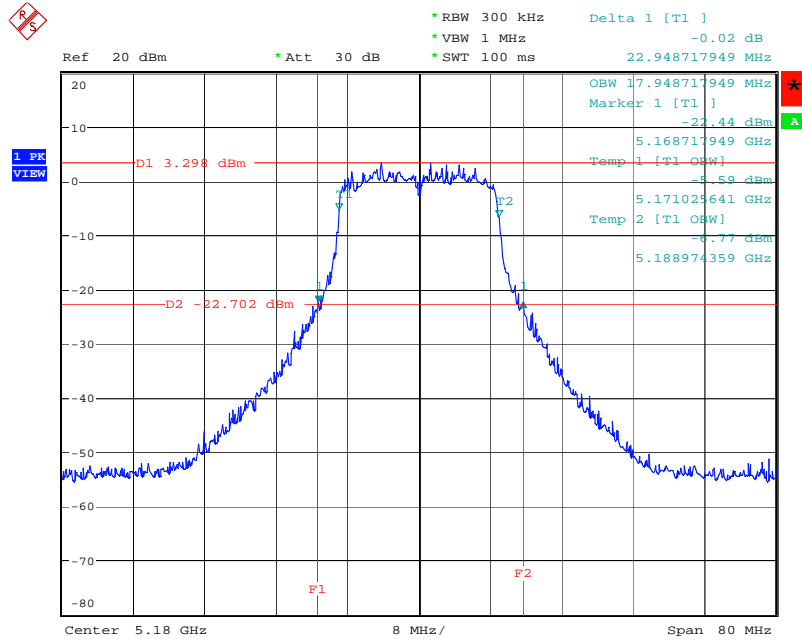

Date: 20.MAR.2008 20:02:36

26 dB Bandwidth Plot on Configuration IEEE 802.11a Ant. 1 / 5260 MHz

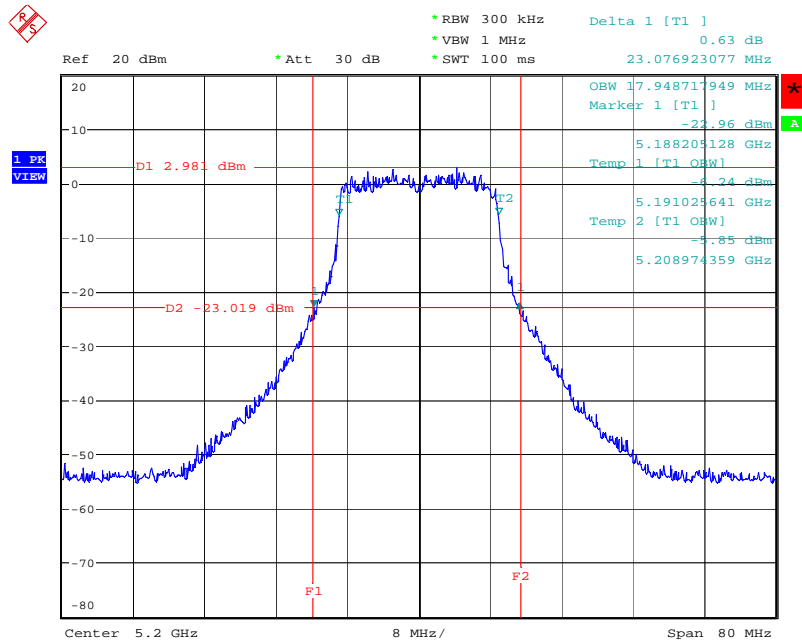

Date: 20.MAR.2008 20:01:01

26 dB Bandwidth Plot on Configuration IEEE 802.11a Ant. 1 / 5240 MHz

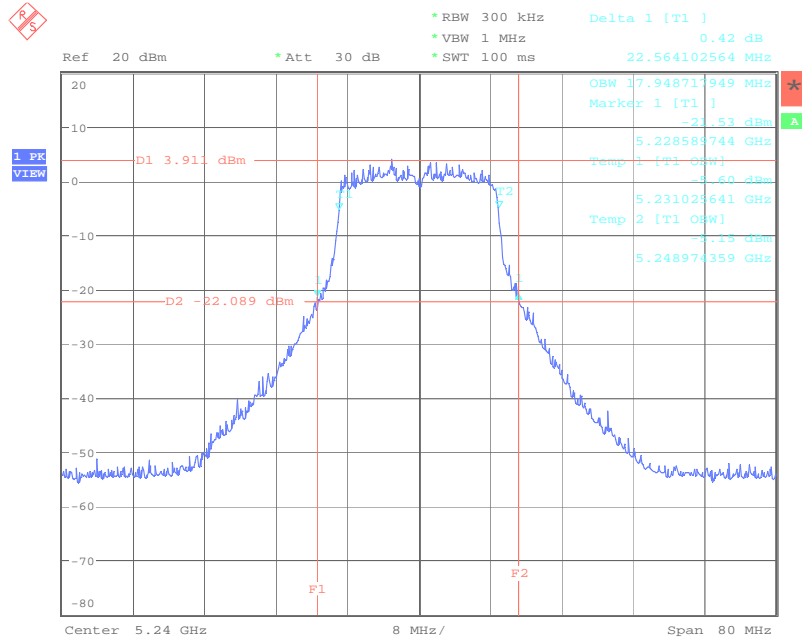

Date: 20.MAR.2008 19:58:48

26 dB Bandwidth Plot on Configuration IEEE 802.11a Ant. 1 / 5260 MHz

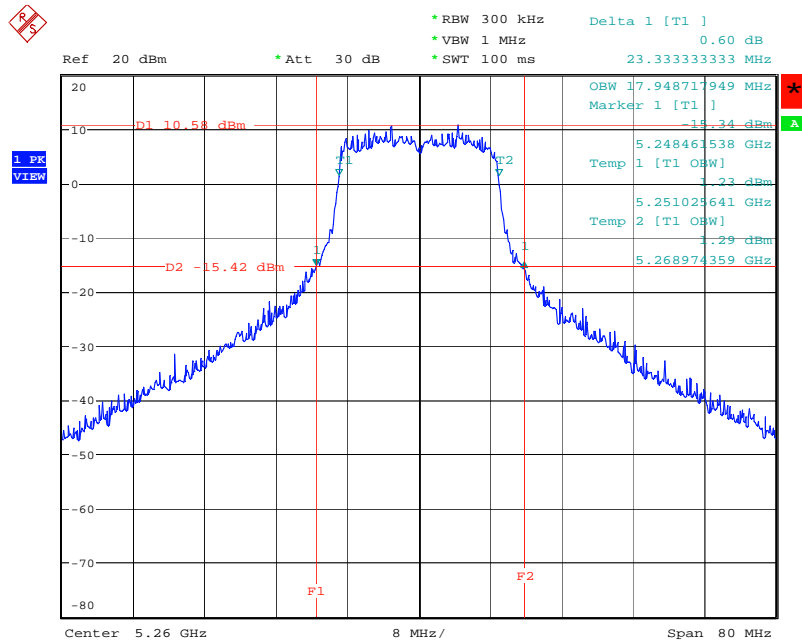

Date: 20.MAR.2008 19:57:15

26 dB Bandwidth Plot on Configuration IEEE 802.11a Ant. 1 / 5300 MHz

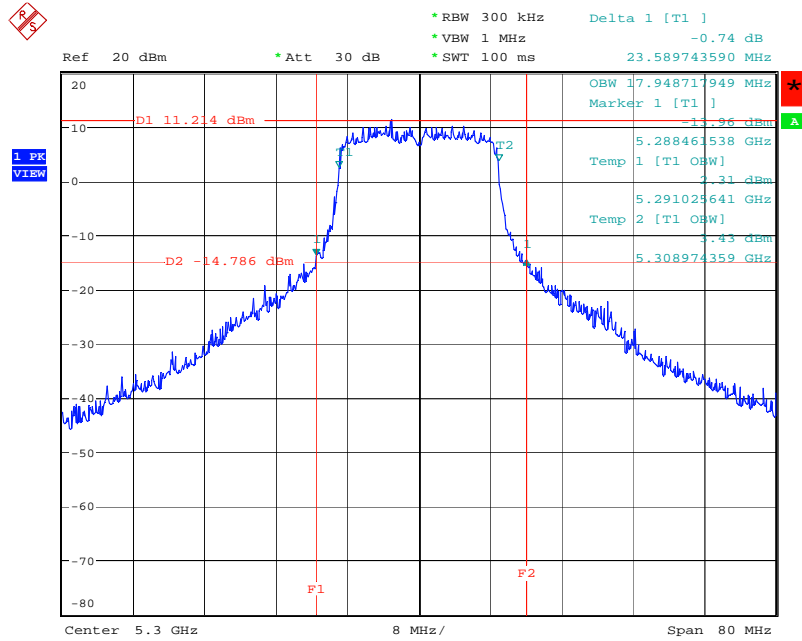

Date: 20.MAR.2008 19:56:16

26 dB Bandwidth Plot on Configuration IEEE 802.11a Ant. 1 / 5320 MHz

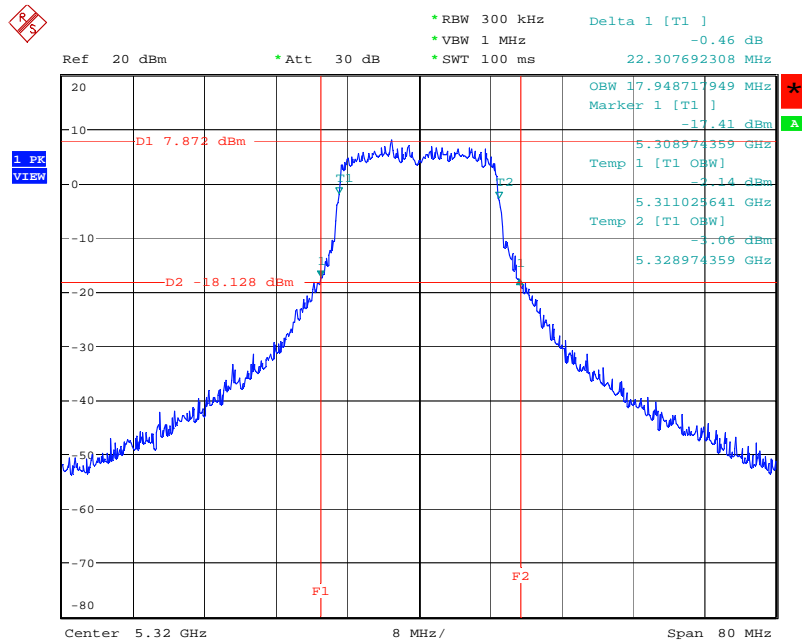

Date: 20.MAR.2008 19:55:25

26 dB Bandwidth Plot on Configuration IEEE 802.11a Ant. 1 / 5500 MHz

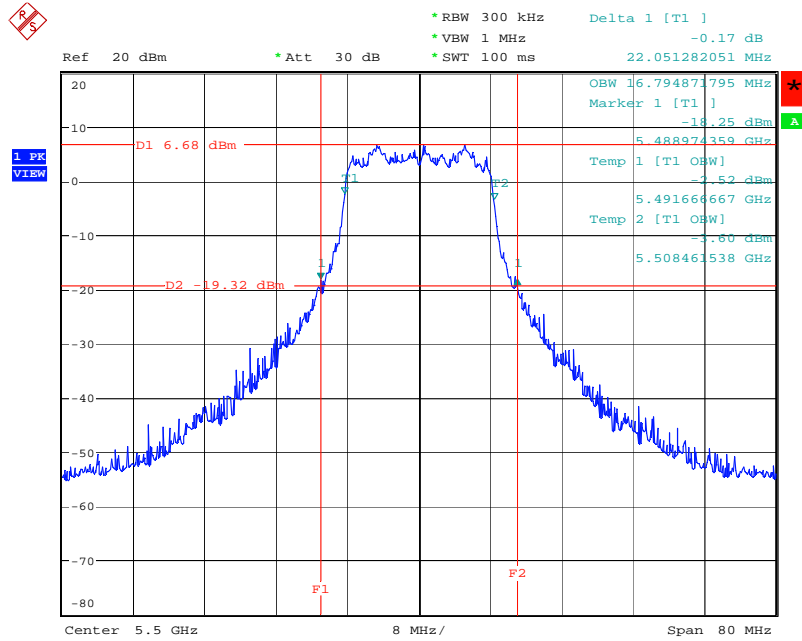

Date: 20.MAR.2008 20:18:38

26 dB Bandwidth Plot on Configuration IEEE 802.11a Ant. 1 / 5580 MHz

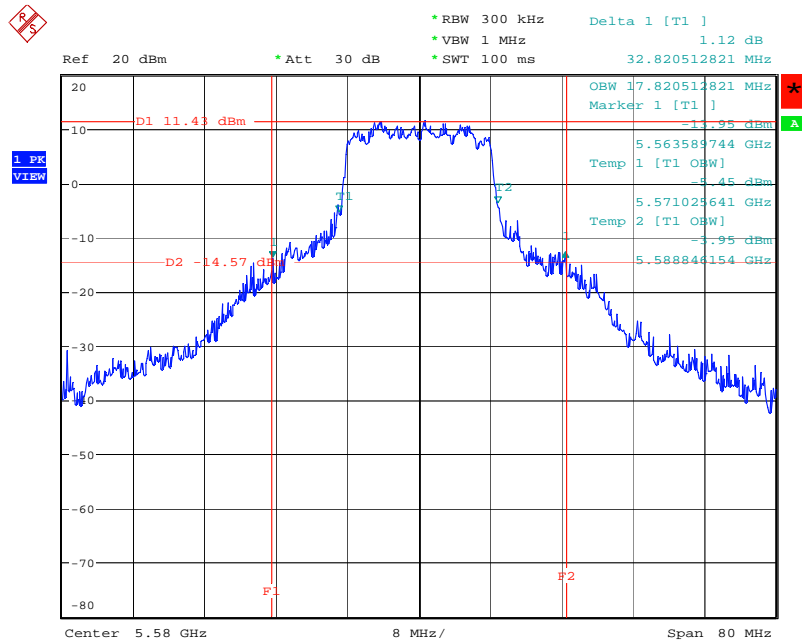

Date: 20.MAR.2008 20:17:40

26 dB Bandwidth Plot on Configuration IEEE 802.11a Ant. 1 / 5700 MHz

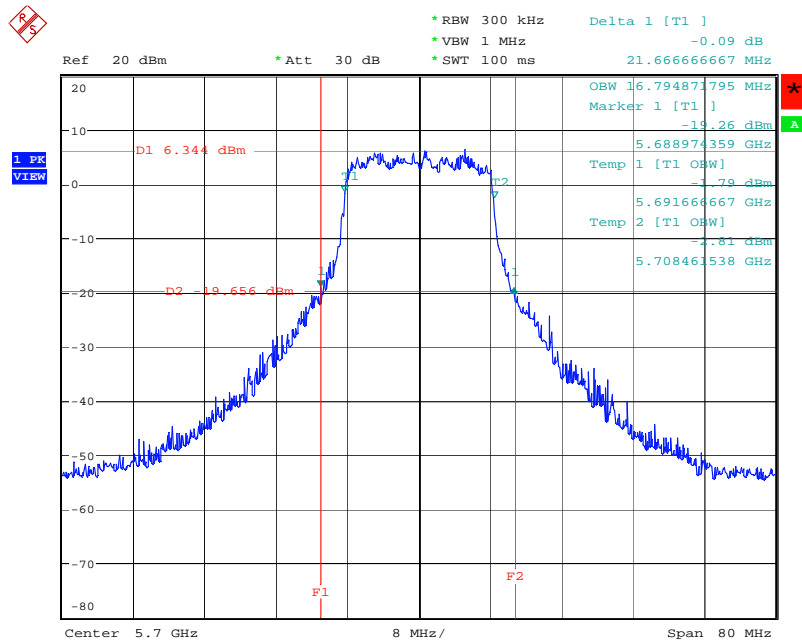

Date: 20.MAR.2008 20:16:39

26 dB Bandwidth Plot on Configuration IEEE 802.11a Ant. 5 / 5180 MHz

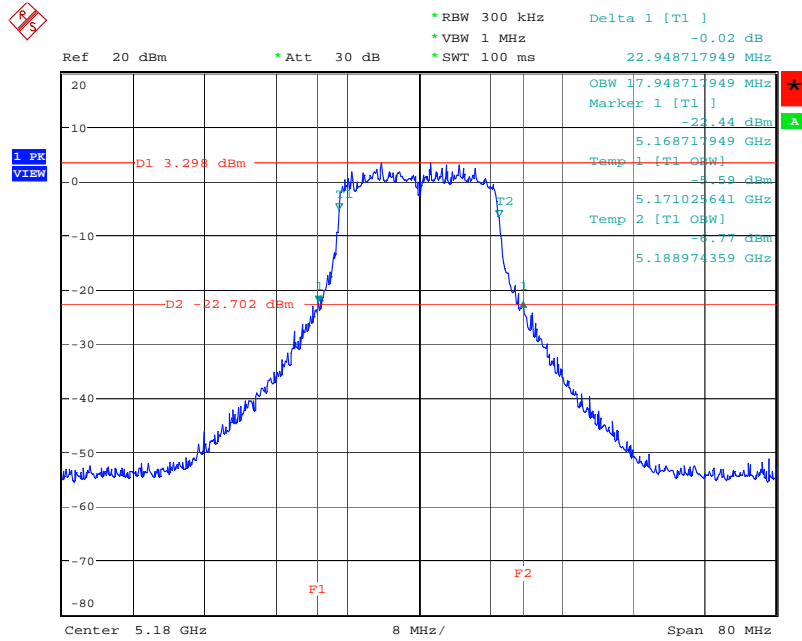

Date: 20.MAR.2008 20:02:36

26 dB Bandwidth Plot on Configuration IEEE 802.11a Ant. 5 / 5260 MHz

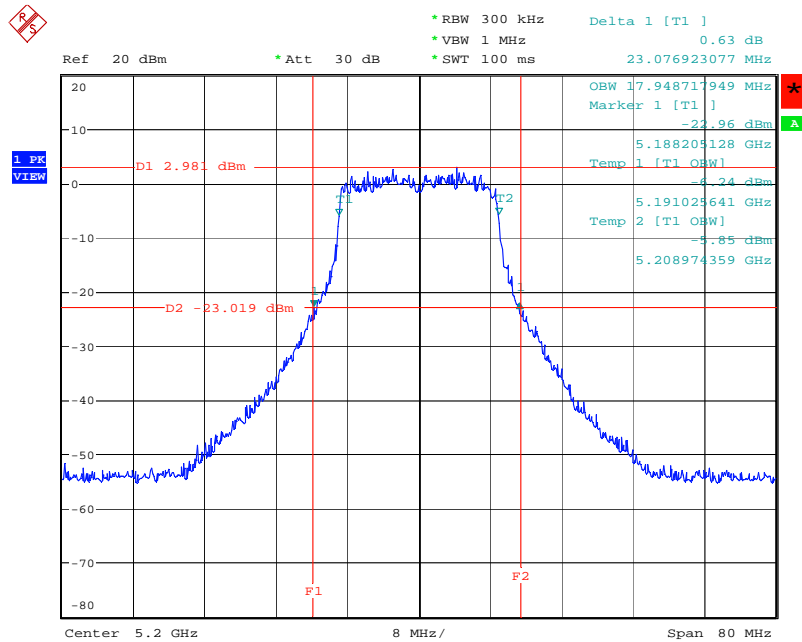

Date: 20.MAR.2008 20:01:01

26 dB Bandwidth Plot on Configuration IEEE 802.11a Ant. 5 / 5240 MHz

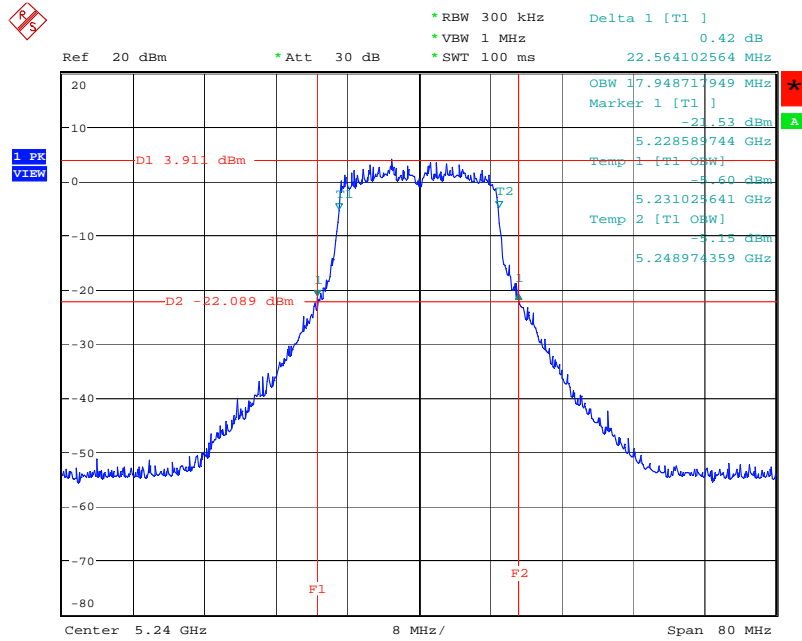

Date: 20.MAR.2008 19:58:48

26 dB Bandwidth Plot on Configuration IEEE 802.11a Ant. 5 / 5260 MHz

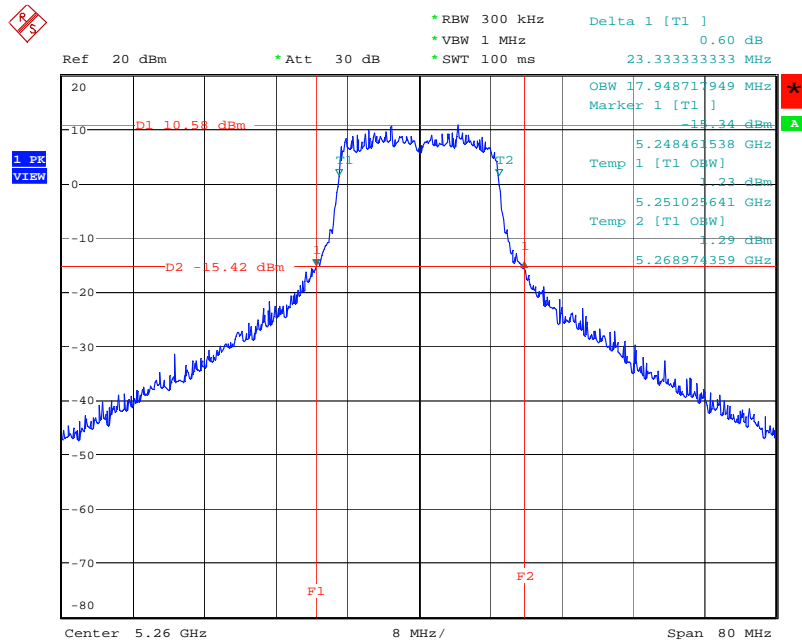

Date: 20.MAR.2008 19:57:15

26 dB Bandwidth Plot on Configuration IEEE 802.11a Ant. 5 / 5300 MHz

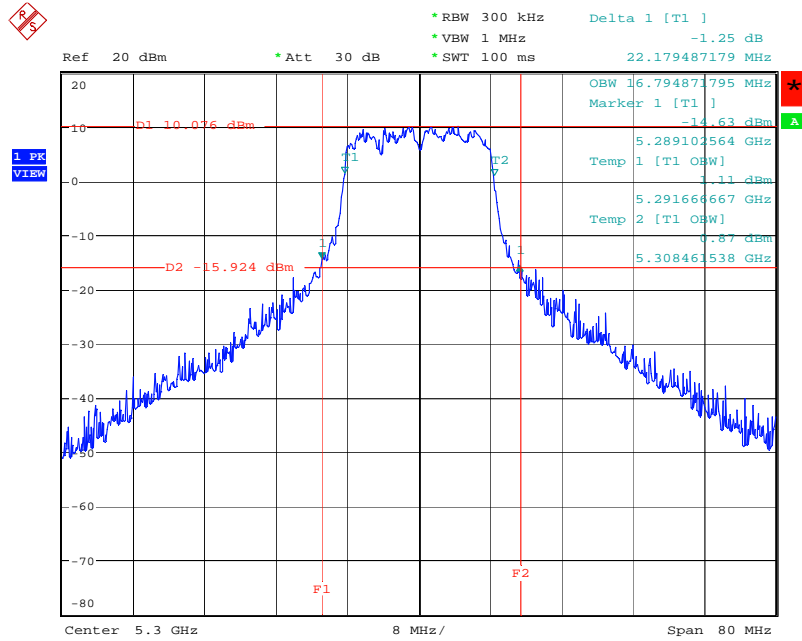

Date: 21.MAR.2008 16:44:56

26 dB Bandwidth Plot on Configuration IEEE 802.11a Ant. 5 / 5320 MHz

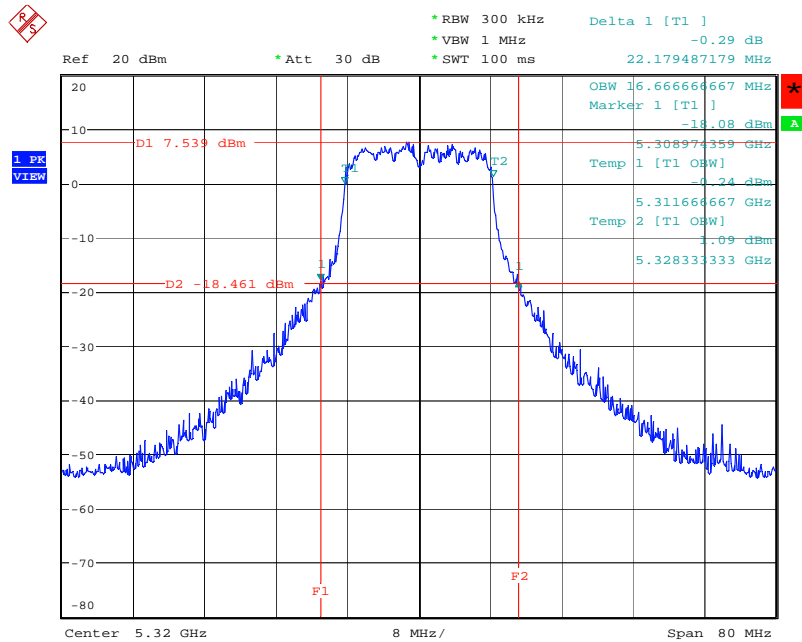

Date: 21.MAR.2008 16:45:47

26 dB Bandwidth Plot on Configuration IEEE 802.11a Ant. 5 / 5500 MHz

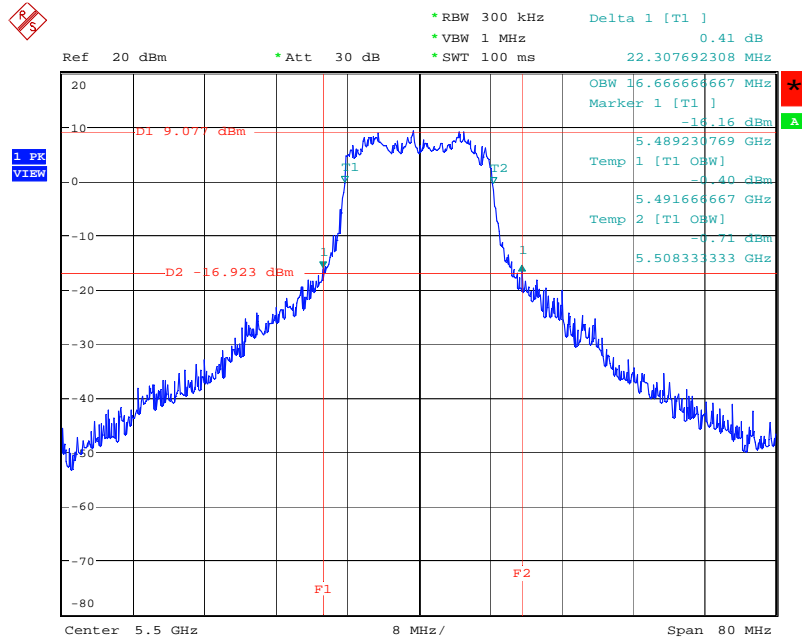

Date: 21.MAR.2008 16:46:57

26 dB Bandwidth Plot on Configuration IEEE 802.11a Ant. 5 / 5580 MHz

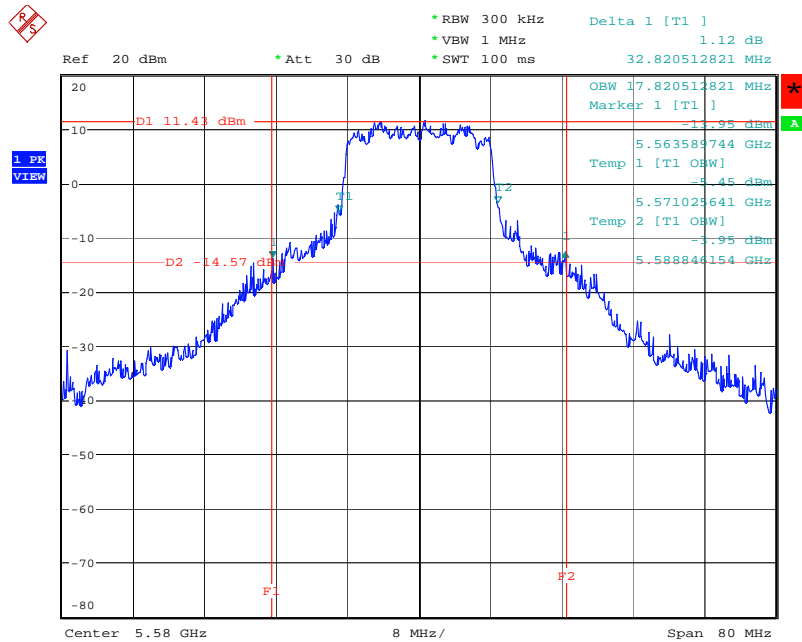

Date: 20.MAR.2008 20:17:40

26 dB Bandwidth Plot on Configuration IEEE 802.11a Ant. 5 / 5700 MHz

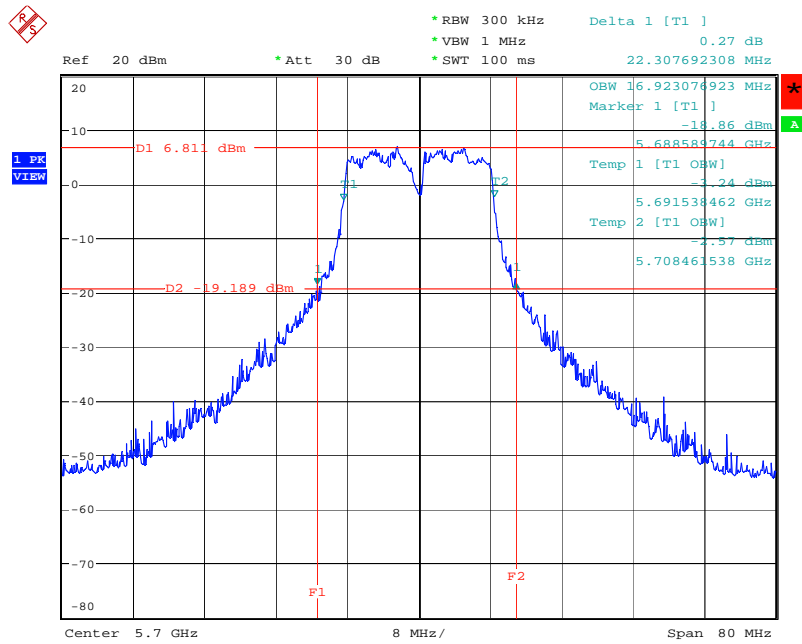

Date: 21.MAR.2008 16:47:51

26 dB Bandwidth Plot on Configuration IEEE 802.11a Ant. 6 / 5180 MHz

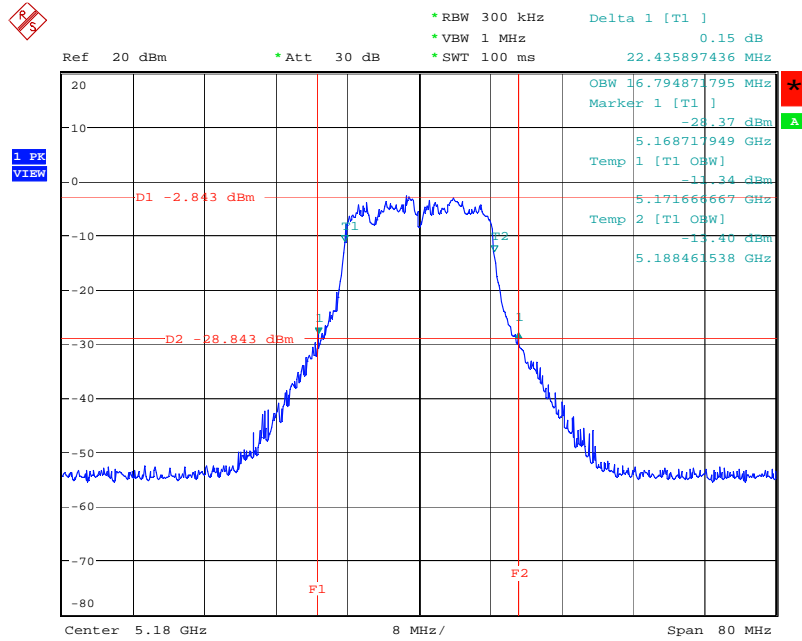

Date: 25.MAR.2008 14:25:10

26 dB Bandwidth Plot on Configuration IEEE 802.11a Ant. 6 / 5260 MHz

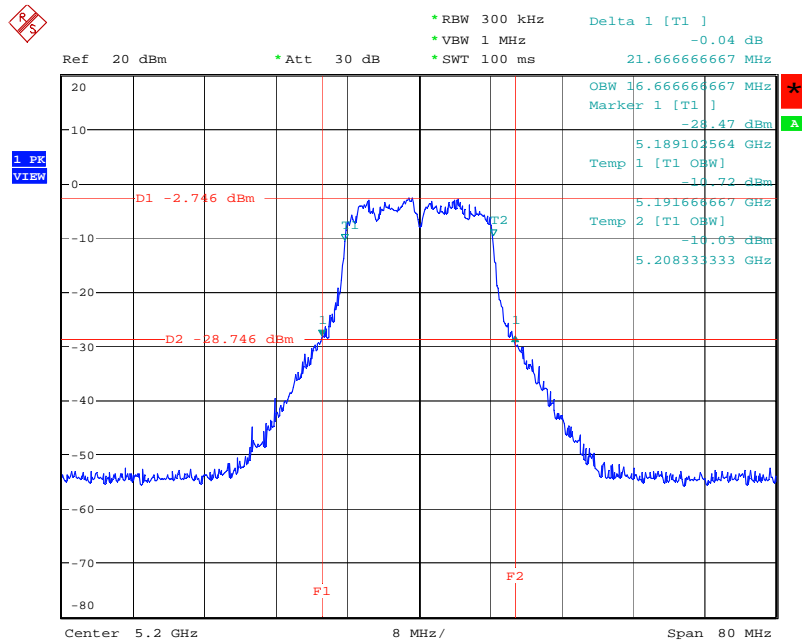

Date: 25.MAR.2008 14:26:12

26 dB Bandwidth Plot on Configuration IEEE 802.11a Ant. 6 / 5240 MHz

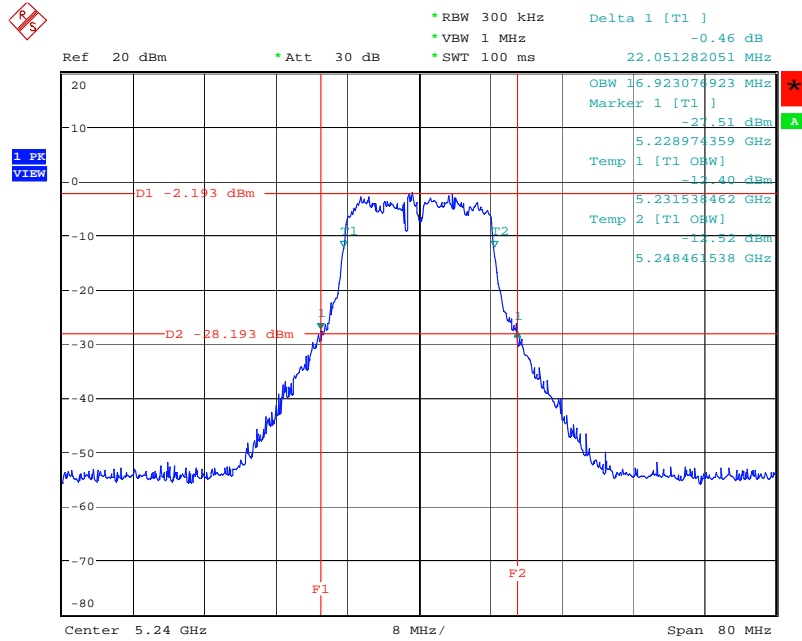

Date: 25.MAR.2008 14:27:05

26 dB Bandwidth Plot on Configuration IEEE 802.11a Ant. 6 / 5260 MHz

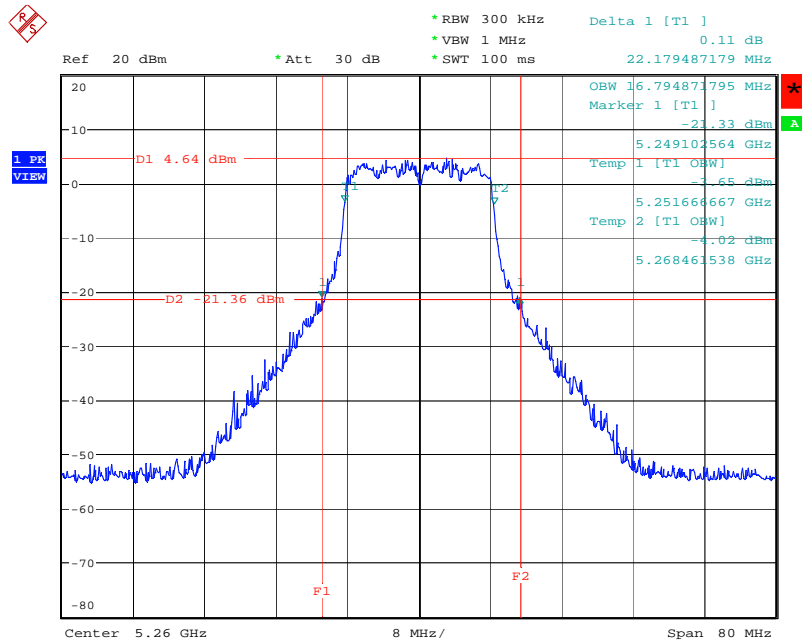

Date: 25.MAR.2008 14:30:10

26 dB Bandwidth Plot on Configuration IEEE 802.11a Ant. 6 / 5300 MHz

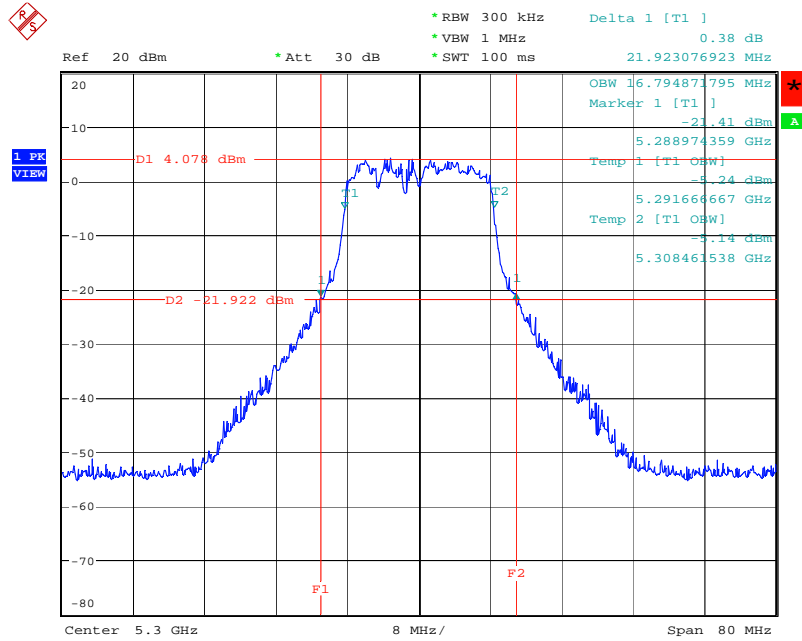

Date: 25.MAR.2008 14:31:00

26 dB Bandwidth Plot on Configuration IEEE 802.11a Ant. 6 / 5320 MHz

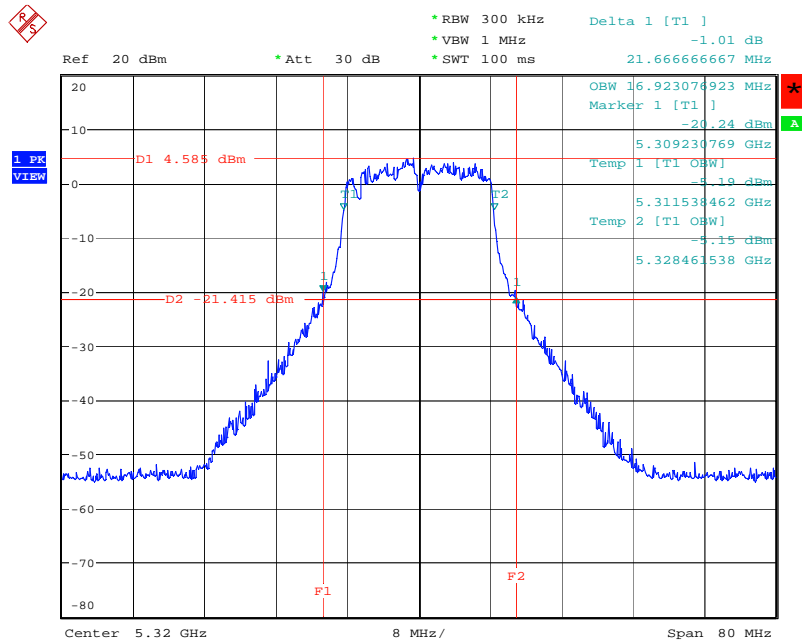

Date: 25.MAR.2008 14:31:38

26 dB Bandwidth Plot on Configuration IEEE 802.11a Ant. 6 / 5500 MHz

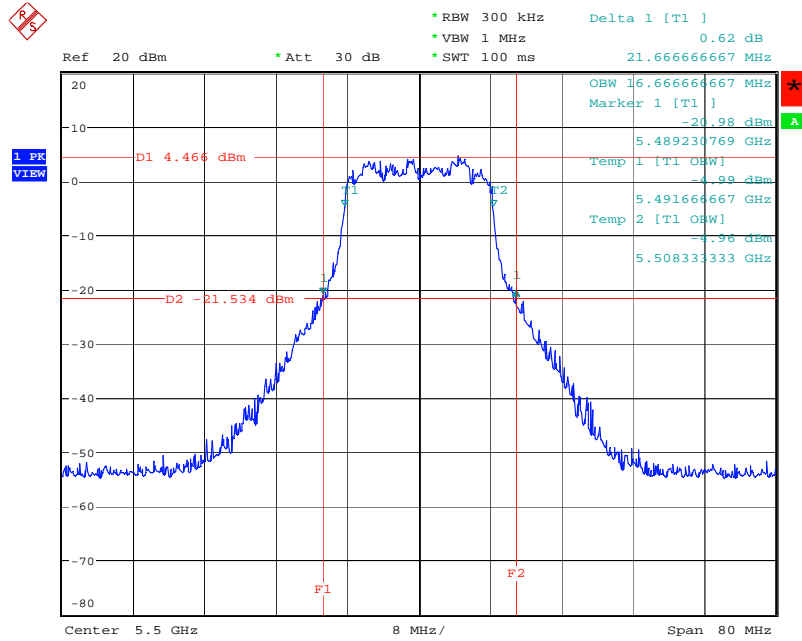

Date: 25.MAR.2008 14:32:43

26 dB Bandwidth Plot on Configuration IEEE 802.11a Ant. 6 / 5580 MHz

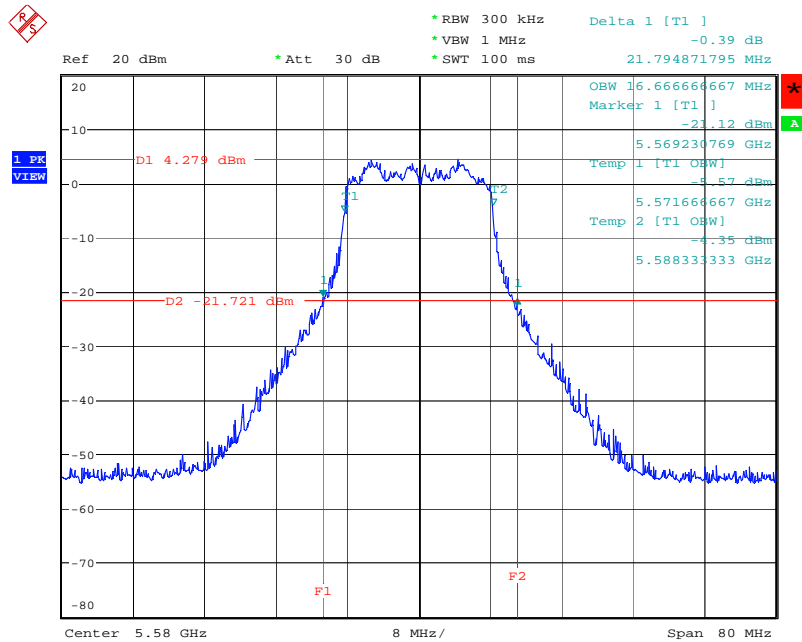

Date: 25.MAR.2008 14:33:52

26 dB Bandwidth Plot on Configuration IEEE 802.11a Ant. 6 / 5700 MHz

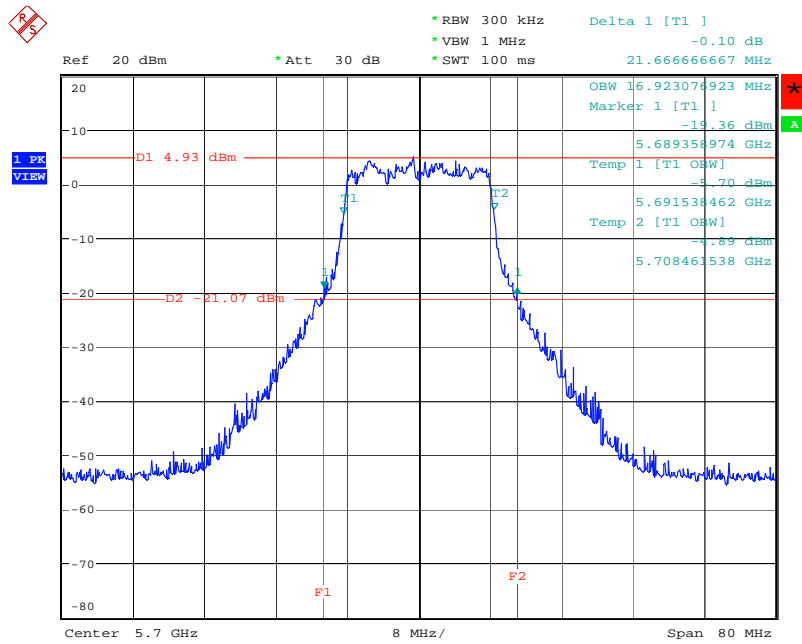

Date: 25.MAR.2008 14:34:49

26 dB Bandwidth Plot on Configuration IEEE 802.11a Ant. 7 / 5180 MHz

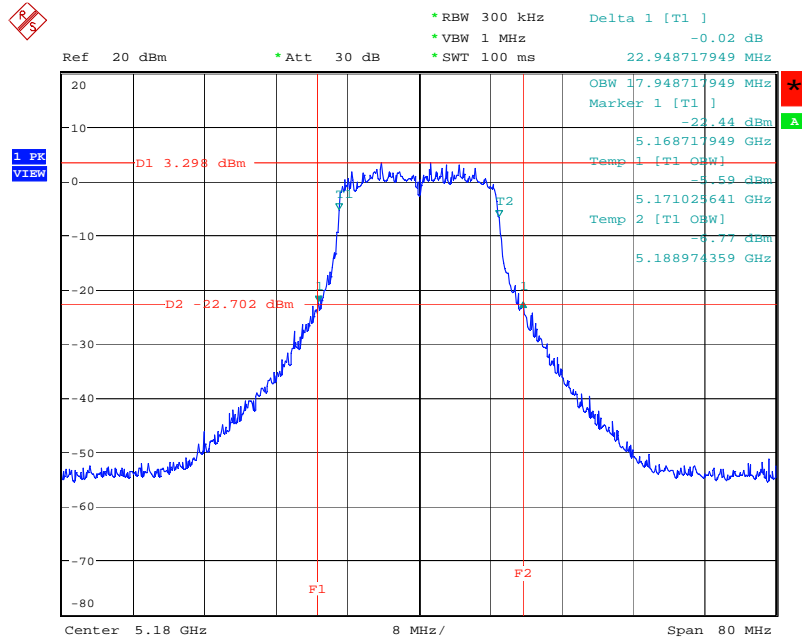

Date: 20.MAR.2008 20:02:36

26 dB Bandwidth Plot on Configuration IEEE 802.11a Ant. 7 / 5260 MHz

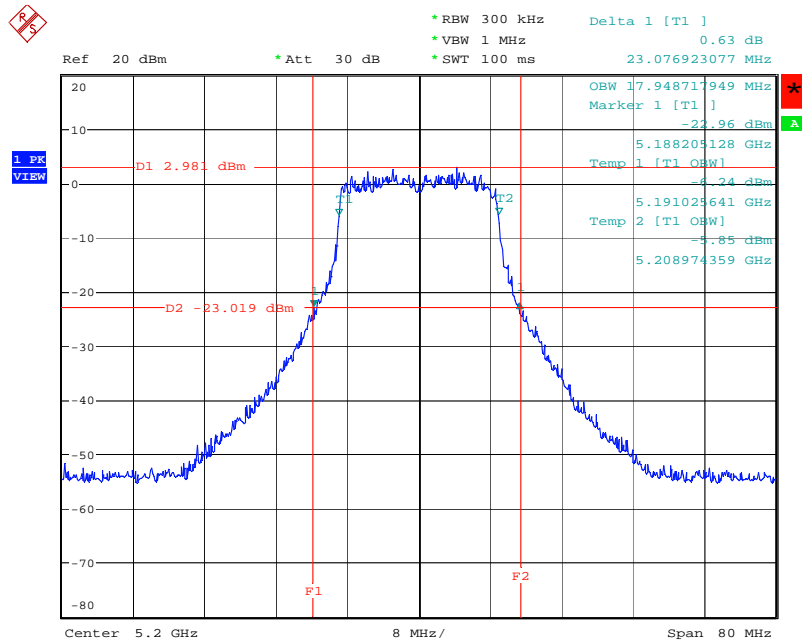

Date: 20.MAR.2008 20:01:01

26 dB Bandwidth Plot on Configuration IEEE 802.11a Ant. 7 / 5240 MHz

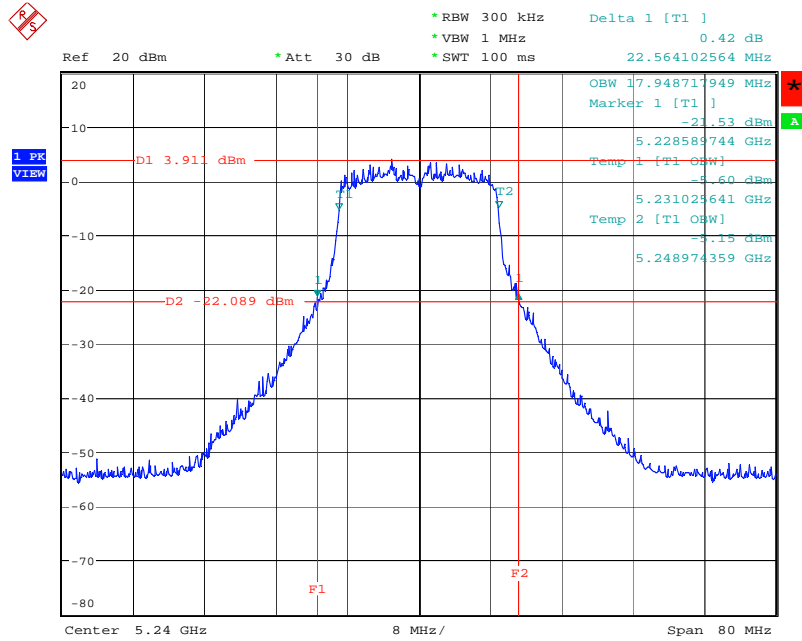

Date: 20.MAR.2008 19:58:48

26 dB Bandwidth Plot on Configuration IEEE 802.11a Ant. 7 / 5260 MHz

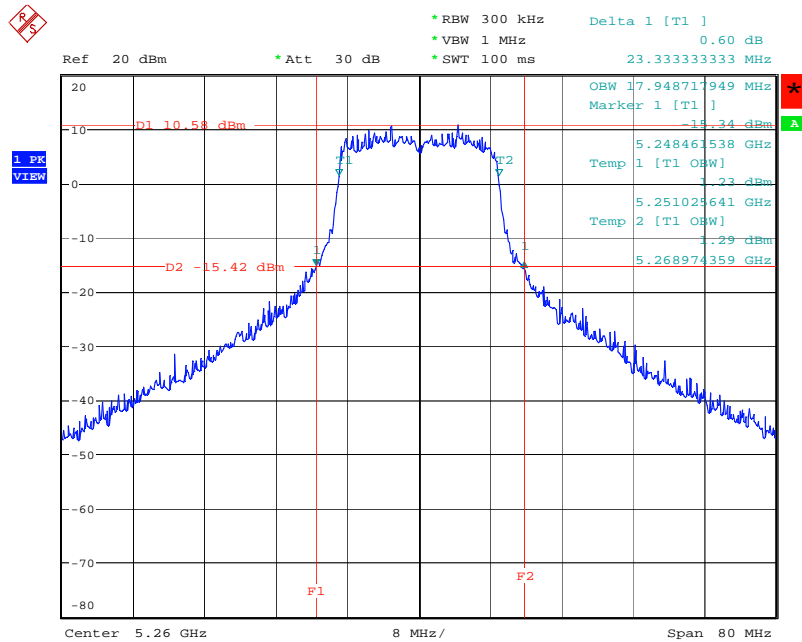

Date: 20.MAR.2008 19:57:15

26 dB Bandwidth Plot on Configuration IEEE 802.11a Ant. 7 / 5300 MHz

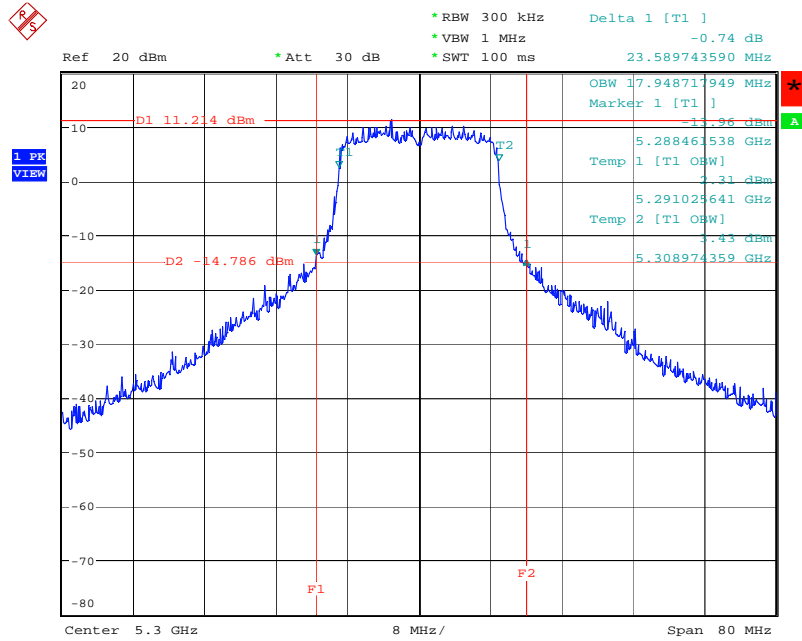

Date: 20.MAR.2008 19:56:16

26 dB Bandwidth Plot on Configuration IEEE 802.11a Ant. 7 / 5320 MHz

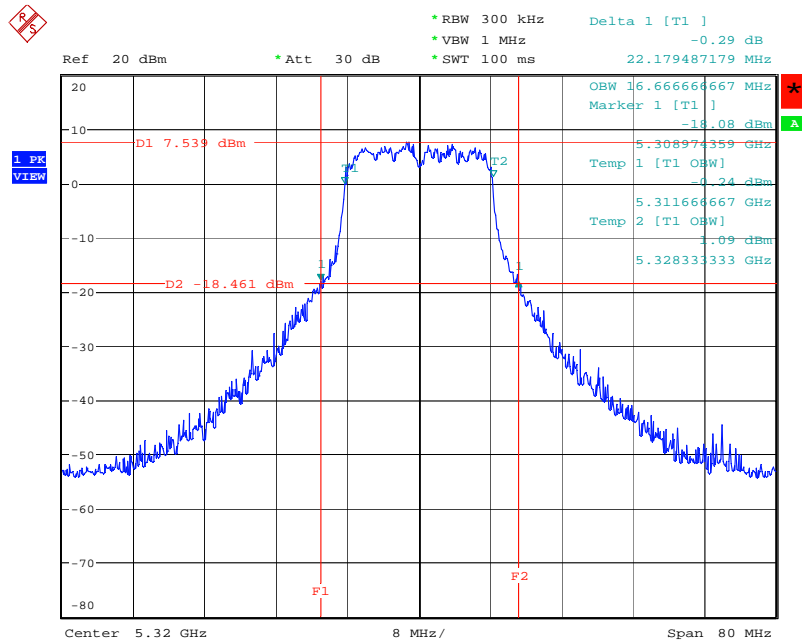

Date: 21.MAR.2008 16:45:47

26 dB Bandwidth Plot on Configuration IEEE 802.11a Ant. 7 / 5500 MHz

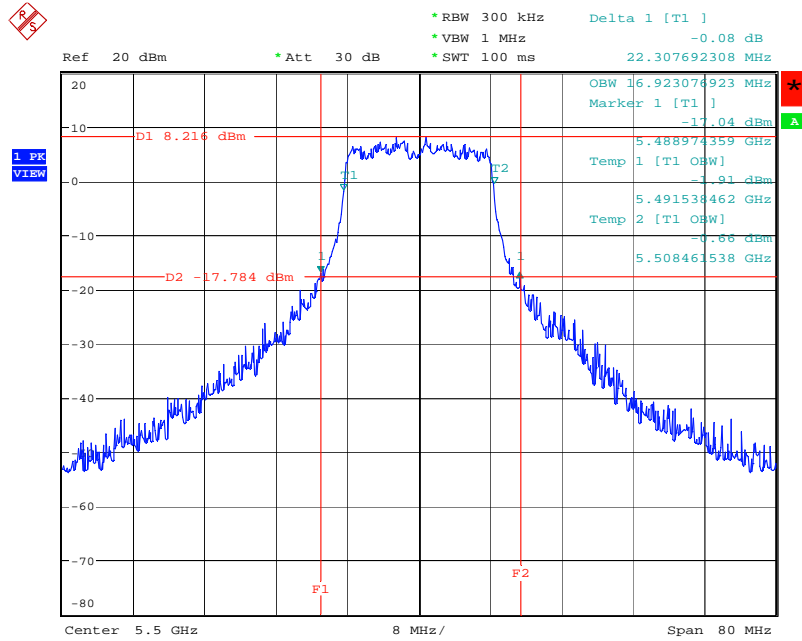

Date: 26.MAR.2008 17:33:38

26 dB Bandwidth Plot on Configuration IEEE 802.11a Ant. 7 / 5580 MHz

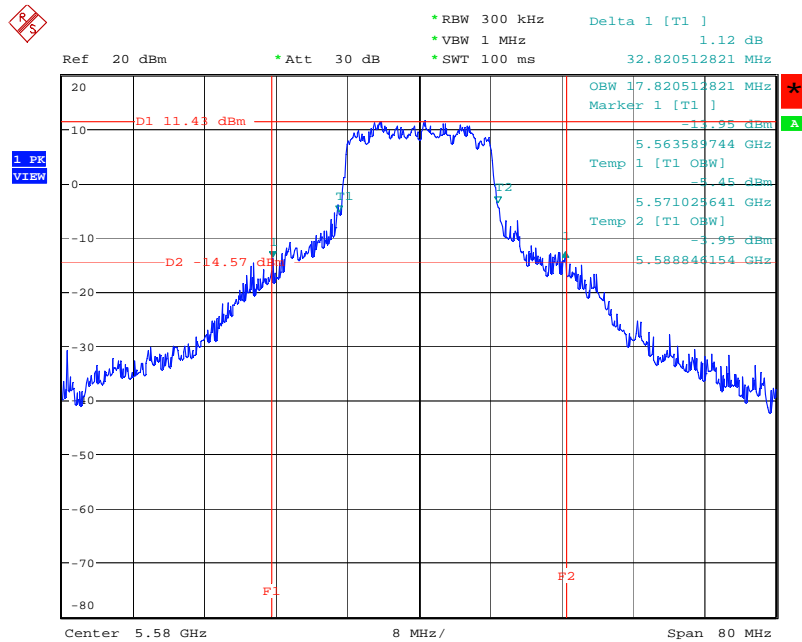

Date: 20.MAR.2008 20:17:40

26 dB Bandwidth Plot on Configuration IEEE 802.11a Ant. 7 / 5700 MHz

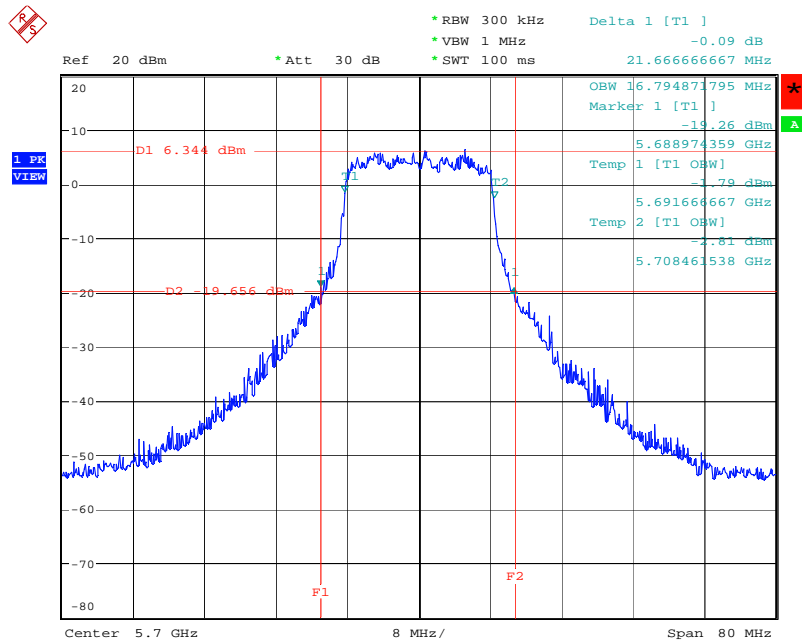

Date: 20.MAR.2008 20:16:39

4.3. Maximum Conducted Output Power Measurement

4.3.1. Limit

For the band 5.15~5.25 GHz, the maximum conducted output power over the frequency band of operation shall not exceed the lesser of 50 mW (17dBm) or $4 \text{ dBm} + 10\log B$, where B is the 26 dB emissions bandwidth in MHz. If transmitting antennas of directional gain greater than 6 dBi are used, the peak output power and power density from the intentional radiator shall be reduced by the amount in dB that the directional gain of the antenna exceeds 6 dBi.

For the 5.25-5.35 GHz and 5.470-5.725 GHz bands, the maximum conducted output power over the frequency bands of operation shall not exceed the lesser of 250 mW (24dBm) or $11 \text{ dBm} + 10\log B$. If transmitting antennas of directional gain greater than 6 dBi are used, the peak output power and power density from the intentional radiator shall be reduced by the amount in dB that the directional gain of the antenna exceeds 6 dBi.

For the band 5.725-5.825 GHz, the maximum conducted output power over the frequency band of operation shall not exceed the lesser of 1 W (30dBm) or $17 \text{ dBm} + 10\log B$. If transmitting antennas of directional gain greater than 6 dBi are used, the peak output power and power density from the intentional radiator shall be reduced by the amount in dB that the directional gain of the antenna exceeds 6 dBi. However, fixed point-to-point U-NII devices operating in this band may employ transmitting antennas with directional gain up to 23 dBi without any corresponding reduction in the transmitter peak output power and peak power spectral density. For fixed, point-to-point U-NII transmitters that employ a directional antenna gain greater than 23 dBi, a 1 dB reduction in peak transmitter power and peak power spectral density for each 1 dB of antenna gain in excess of 23 dBi would be required.

4.3.2. Measuring Instruments and Setting

Please refer to section 5 of equipments list in this report. The following table is the setting of the spectrum analyzer.

Spectrum Parameter	Setting
Attenuation	Auto
Span Frequency	Encompass the entire emissions bandwidth (EBW) of the signal
RB	1000 kHz
VB	300 kHz
Detector	PEAK
Trace	Max Hold
Sweep Time	Auto

4.3.3. Test Procedures

1. The transmitter output (antenna port) was connected to the spectrum analyzer.
2. Test was performed in accordance with FCC Public Notice DA 02-2138, August 30, 2002.
3. When measuring maximum conducted output power with multiple antenna systems, add every result of the values by mathematic formula.

4.3.4. Test Setup Layout

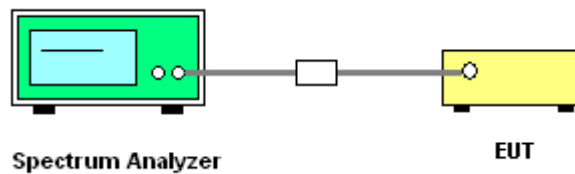

4.3.5. Test Deviation

There is no deviation with the original standard.

4.3.6. EUT Operation during Test

The EUT was programmed to be in continuously transmitting mode.

4.3.7. Test Result of Maximum Conducted Output Power

Temperature	22°C	Humidity	61%
Test Engineer	Sam Chen	Configurations	802.11a / Antenna 1

Configuration IEEE 802.11a Ant. 1-1

Channel	Frequency	Conducted Power (dBm)	Max. Limit (dBm)	Result
36	5180 MHz	12.47	17.00	Complies
40	5260 MHz	12.13	17.00	Complies
48	5240 MHz	11.91	17.00	Complies
52	5260 MHz	18.64	24.00	Complies
60	5300 MHz	17.37	24.00	Complies
64	5320 MHz	13.56	24.00	Complies
100	5500 MHz	11.79	24.00	Complies
116	5580 MHz	18.13	24.00	Complies
140	5700 MHz	13.37	24.00	Complies

Configuration IEEE 802.11a Ant. 1-2

Channel	Frequency	Conducted Power (dBm)	Max. Limit (dBm)	Result
36	5180 MHz	11.43	17.00	Complies
40	5260 MHz	10.97	17.00	Complies
48	5240 MHz	10.96	17.00	Complies
52	5260 MHz	18.00	24.00	Complies
60	5300 MHz	18.14	24.00	Complies
64	5320 MHz	14.84	24.00	Complies
100	5500 MHz	12.83	24.00	Complies
116	5580 MHz	19.11	24.00	Complies
140	5700 MHz	12.29	24.00	Complies

Configuration IEEE 802.11a Ant. 1-3

Channel	Frequency	Conducted Power (dBm)	Max. Limit (dBm)	Result
36	5180 MHz	11.39	17.00	Complies
40	5260 MHz	11.36	17.00	Complies
48	5240 MHz	12.36	17.00	Complies
52	5260 MHz	18.81	24.00	Complies
60	5300 MHz	17.30	24.00	Complies
64	5320 MHz	13.59	24.00	Complies
100	5500 MHz	13.60	24.00	Complies
116	5580 MHz	18.29	24.00	Complies
140	5700 MHz	12.25	24.00	Complies

Configuration IEEE 802.11a Ant. 1-1 +Ant. 1-2 + Ant. 1-3

Channel	Frequency	Conducted Power (dBm)	Max. Limit (dBm)	Result
36	5180 MHz	16.56	17.00	Complies
40	5260 MHz	16.28	17.00	Complies
48	5240 MHz	16.55	17.00	Complies
52	5260 MHz	23.27	24.00	Complies
60	5300 MHz	22.39	24.00	Complies
64	5320 MHz	18.81	24.00	Complies
100	5500 MHz	17.57	24.00	Complies
116	5580 MHz	23.30	24.00	Complies
140	5700 MHz	17.44	24.00	Complies

Temperature	22°C	Humidity	61%
Test Engineer	Sam Chen	Configurations	802.11a / Antenna 5

Configuration IEEE 802.11a Ant. 5-1

Channel	Frequency	Conducted Power (dBm)	Max. Limit (dBm)	Result
36	5180 MHz	12.47	17.00	Complies
40	5260 MHz	12.13	17.00	Complies
48	5240 MHz	11.91	17.00	Complies
52	5260 MHz	18.64	24.00	Complies
60	5300 MHz	16.55	24.00	Complies
64	5320 MHz	14.23	24.00	Complies
100	5500 MHz	14.82	24.00	Complies
116	5580 MHz	18.13	24.00	Complies
140	5700 MHz	15.13	24.00	Complies

Configuration IEEE 802.11a Ant. 5-2

Channel	Frequency	Conducted Power (dBm)	Max. Limit (dBm)	Result
36	5180 MHz	11.43	17.00	Complies
40	5260 MHz	10.97	17.00	Complies
48	5240 MHz	10.96	17.00	Complies
52	5260 MHz	18.00	24.00	Complies
60	5300 MHz	17.13	24.00	Complies
64	5320 MHz	14.95	24.00	Complies
100	5500 MHz	16.55	24.00	Complies
116	5580 MHz	19.11	24.00	Complies
140	5700 MHz	13.55	24.00	Complies

Configuration IEEE 802.11a Ant. 5-3

Channel	Frequency	Conducted Power (dBm)	Max. Limit (dBm)	Result
36	5180 MHz	11.39	17.00	Complies
40	5260 MHz	11.36	17.00	Complies
48	5240 MHz	12.36	17.00	Complies
52	5260 MHz	18.81	24.00	Complies
60	5300 MHz	18.33	24.00	Complies
64	5320 MHz	15.81	24.00	Complies
100	5500 MHz	16.44	24.00	Complies
116	5580 MHz	18.29	24.00	Complies
140	5700 MHz	13.52	24.00	Complies

Configuration IEEE 802.11a Ant. 5-1 +Ant. 5-2 + Ant. 5-3

Channel	Frequency	Conducted Power (dBm)	Max. Limit (dBm)	Result
36	5180 MHz	16.56	17.00	Complies
40	5260 MHz	16.28	17.00	Complies
48	5240 MHz	16.55	17.00	Complies
52	5260 MHz	23.27	24.00	Complies
60	5300 MHz	22.17	24.00	Complies
64	5320 MHz	19.82	24.00	Complies
100	5500 MHz	20.78	24.00	Complies
116	5580 MHz	23.30	24.00	Complies
140	5700 MHz	18.91	24.00	Complies

Temperature	22°C	Humidity	61%
Test Engineer	Sam Chen	Configurations	802.11a / Antenna 6

Configuration IEEE 802.11a Ant. 6-1

Channel	Frequency	Conducted Power (dBm)	Max. Limit (dBm)	Result
36	5180 MHz	5.81	10.00	Complies
40	5260 MHz	5.51	10.00	Complies
48	5240 MHz	5.80	10.00	Complies
52	5260 MHz	12.34	17.00	Complies
60	5300 MHz	11.12	17.00	Complies
64	5320 MHz	11.20	17.00	Complies
100	5500 MHz	10.97	17.00	Complies
116	5580 MHz	11.70	17.00	Complies
140	5700 MHz	13.02	17.00	Complies

Configuration IEEE 802.11a Ant. 6-2

Channel	Frequency	Conducted Power (dBm)	Max. Limit (dBm)	Result
36	5180 MHz	3.82	10.00	Complies
40	5260 MHz	3.69	10.00	Complies
48	5240 MHz	3.60	10.00	Complies
52	5260 MHz	11.02	17.00	Complies
60	5300 MHz	10.96	17.00	Complies
64	5320 MHz	11.37	17.00	Complies
100	5500 MHz	12.06	17.00	Complies
116	5580 MHz	12.15	17.00	Complies
140	5700 MHz	11.44	17.00	Complies

Configuration IEEE 802.11a Ant. 6-3

Channel	Frequency	Conducted Power (dBm)	Max. Limit (dBm)	Result
36	5180 MHz	4.65	10.00	Complies
40	5260 MHz	4.52	10.00	Complies
48	5240 MHz	5.37	10.00	Complies
52	5260 MHz	12.89	17.00	Complies
60	5300 MHz	12.83	17.00	Complies
64	5320 MHz	13.00	17.00	Complies
100	5500 MHz	11.60	17.00	Complies
116	5580 MHz	11.10	17.00	Complies
140	5700 MHz	11.68	17.00	Complies

Configuration IEEE 802.11a Ant. 6-1 +Ant. 6-2 + Ant. 6-3

Channel	Frequency	Conducted Power (dBm)	Max. Limit (dBm)	Result
36	5180 MHz	9.61	10.00	Complies
40	5260 MHz	9.41	10.00	Complies
48	5240 MHz	9.79	10.00	Complies
52	5260 MHz	16.92	17.00	Complies
60	5300 MHz	16.49	17.00	Complies
64	5320 MHz	16.71	17.00	Complies
100	5500 MHz	16.34	17.00	Complies
116	5580 MHz	16.44	17.00	Complies
140	5700 MHz	16.88	17.00	Complies

Temperature	22°C	Humidity	61%
Test Engineer	Sam Chen	Configurations	802.11a / Antenna 7

Configuration IEEE 802.11a Ant. 7-1

Channel	Frequency	Conducted Power (dBm)	Max. Limit (dBm)	Result
36	5180 MHz	12.47	17.00	Complies
40	5260 MHz	12.13	17.00	Complies
48	5240 MHz	11.91	17.00	Complies
52	5260 MHz	18.64	24.00	Complies
60	5300 MHz	17.37	24.00	Complies
64	5320 MHz	14.23	24.00	Complies
100	5500 MHz	13.85	24.00	Complies
116	5580 MHz	18.13	24.00	Complies
140	5700 MHz	13.37	24.00	Complies

Configuration IEEE 802.11a Ant. 7-2

Channel	Frequency	Conducted Power (dBm)	Max. Limit (dBm)	Result
36	5180 MHz	11.42	17.00	Complies
40	5260 MHz	10.97	17.00	Complies
48	5240 MHz	10.96	17.00	Complies
52	5260 MHz	18.00	24.00	Complies
60	5300 MHz	18.14	24.00	Complies
64	5320 MHz	14.95	24.00	Complies
100	5500 MHz	15.35	24.00	Complies
116	5580 MHz	19.11	24.00	Complies
140	5700 MHz	12.29	24.00	Complies

Configuration IEEE 802.11a Ant. 7-3

Channel	Frequency	Conducted Power (dBm)	Max. Limit (dBm)	Result
36	5180 MHz	11.39	17.00	Complies
40	5260 MHz	11.36	17.00	Complies
48	5240 MHz	12.36	17.00	Complies
52	5260 MHz	18.81	24.00	Complies
60	5300 MHz	17.30	24.00	Complies
64	5320 MHz	15.81	24.00	Complies
100	5500 MHz	14.99	24.00	Complies
116	5580 MHz	18.29	24.00	Complies
140	5700 MHz	12.25	24.00	Complies

Configuration IEEE 802.11a Ant. 7-1 +Ant. 7-2 + Ant. 7-3

Channel	Frequency	Conducted Power (dBm)	Max. Limit (dBm)	Result
36	5180 MHz	16.56	17.00	Complies
40	5260 MHz	16.28	17.00	Complies
48	5240 MHz	16.55	17.00	Complies
52	5260 MHz	23.27	24.00	Complies
60	5300 MHz	22.39	24.00	Complies
64	5320 MHz	19.82	24.00	Complies
100	5500 MHz	19.55	24.00	Complies
116	5580 MHz	23.30	24.00	Complies
140	5700 MHz	17.44	24.00	Complies

Conducted Output Power Plot on Configuration IEEE 802.11 a Ant. 1-1 / 5180 MHz

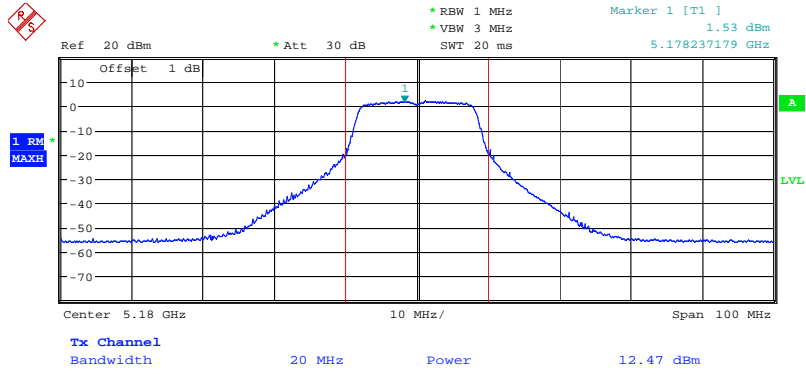

Date: 20.MAR.2008 18:35:55

Conducted Output Power Plot on Configuration IEEE 802.11 a Ant. 1-2 / 5180 MHz

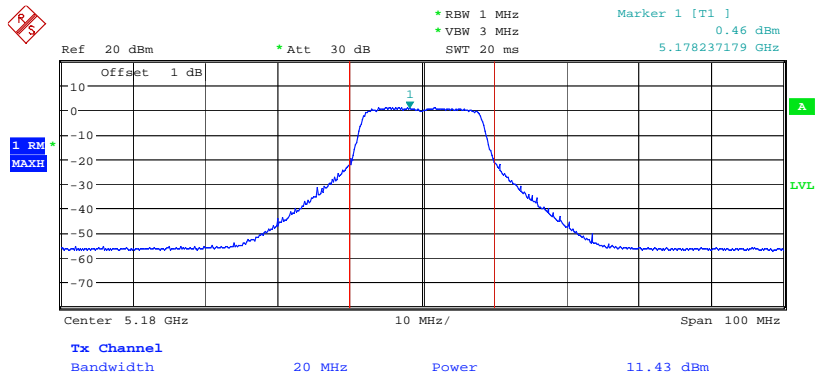

Date: 20.MAR.2008 18:36:32

Conducted Output Power Plot on Configuration IEEE 802.11 a Ant. 1-3 / 5180 MHz

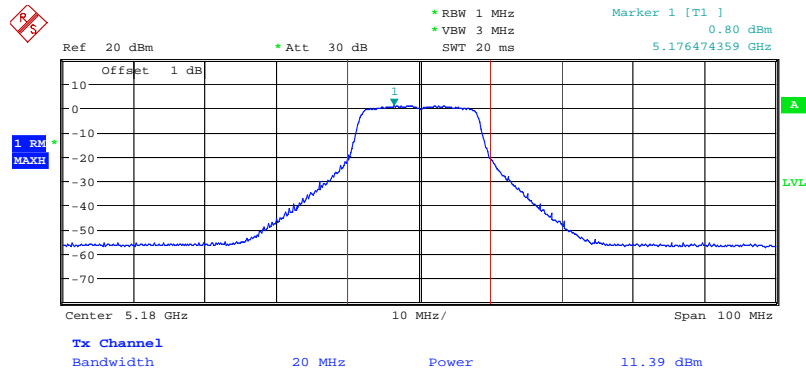

Date: 20.MAR.2008 18:37:06

Conducted Output Power Plot on Configuration IEEE 802.11 a Ant. 1-1 / 5260 MHz

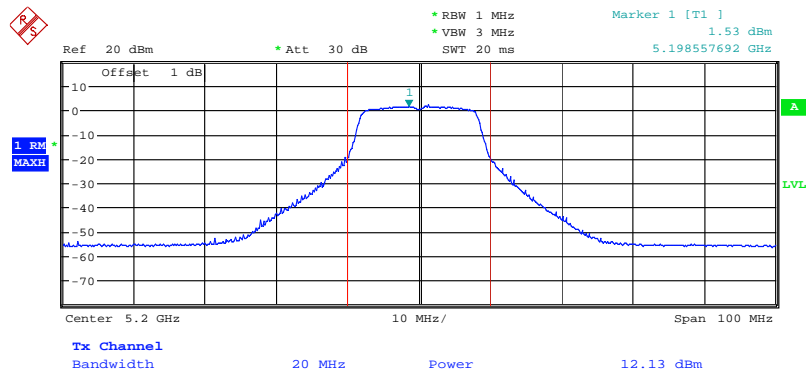

Date: 20.MAR.2008 18:40:02

Conducted Output Power Plot on Configuration IEEE 802.11 a Ant. 1-2 / 5260 MHz

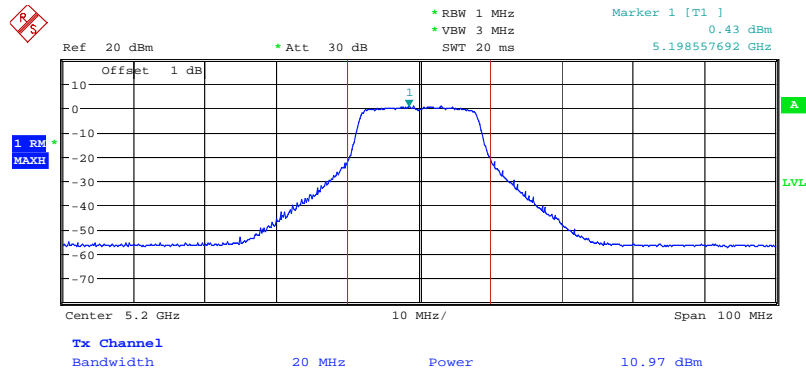

Date: 20.MAR.2008 18:38:52

Conducted Output Power Plot on Configuration IEEE 802.11 a Ant. 1-3 / 5260 MHz

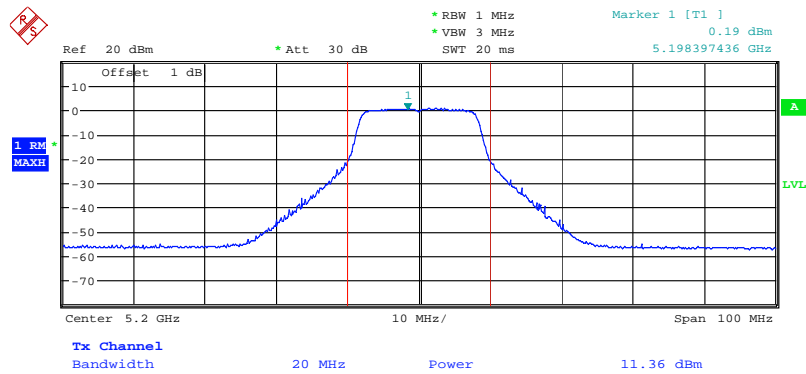

Date: 20.MAR.2008 18:37:59

Conducted Output Power Plot on Configuration IEEE 802.11 a Ant. 1-1 / 5240 MHz

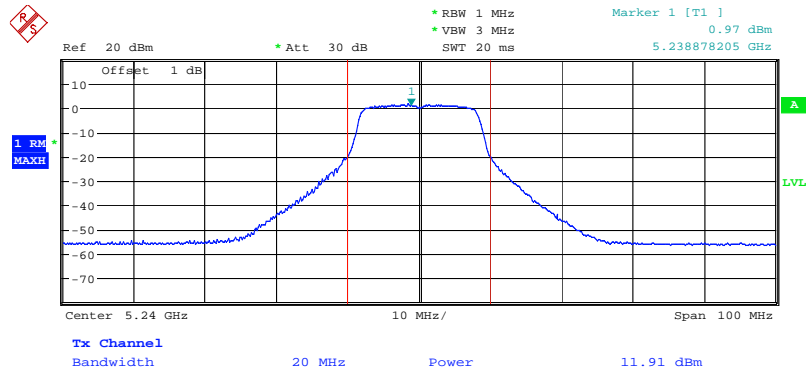

Date: 20.MAR.2008 18:44:25

Conducted Output Power Plot on Configuration IEEE 802.11 a Ant. 1-2 / 5240 MHz

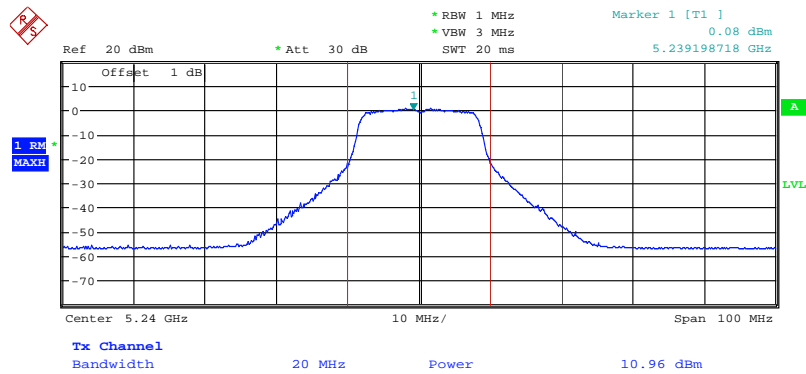

Date: 20.MAR.2008 18:43:44

Conducted Output Power Plot on Configuration IEEE 802.11 a Ant. 1-3 / 5240 MHz

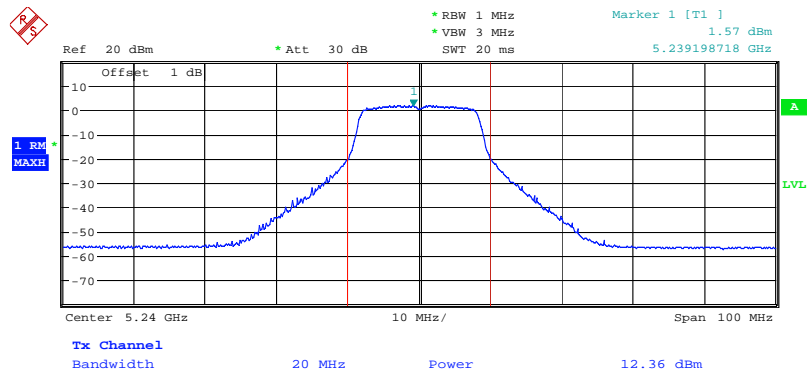

Date: 20.MAR.2008 18:43:10

Conducted Output Power Plot on Configuration IEEE 802.11 a Ant. 1-1 / 5260 MHz

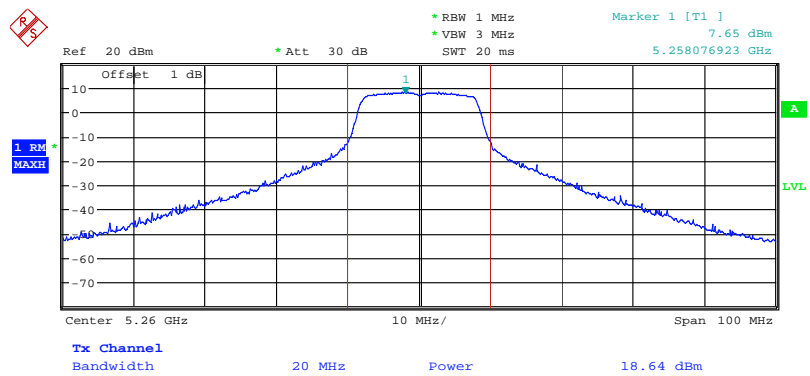

Date: 20.MAR.2008 18:50:43

Conducted Output Power Plot on Configuration IEEE 802.11 a Ant. 1-2 / 5260 MHz

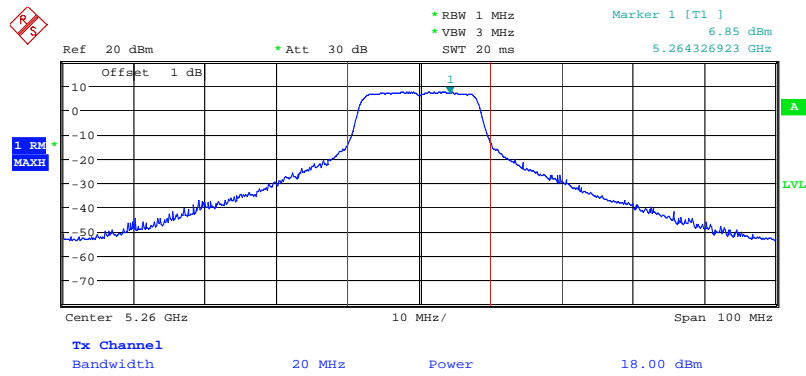

Date: 20.MAR.2008 18:49:21

Conducted Output Power Plot on Configuration IEEE 802.11 a Ant. 1-3 / 5260 MHz

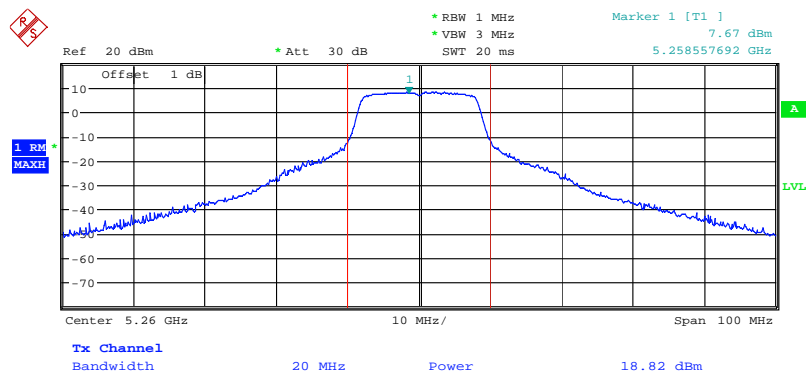

Date: 20.MAR.2008 18:48:23

Conducted Output Power Plot on Configuration IEEE 802.11 a Ant. 1-1 / 5300 MHz

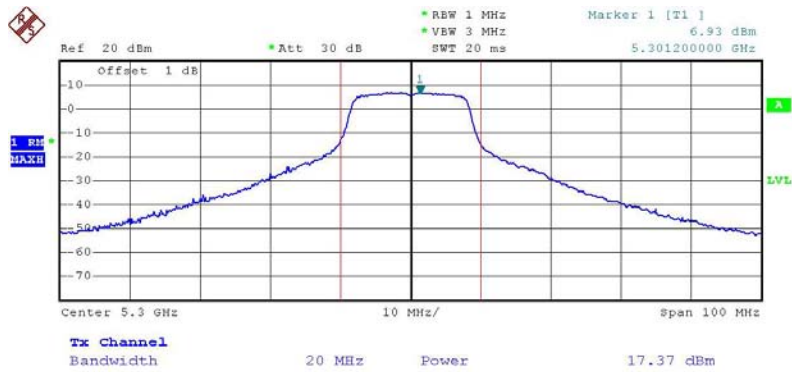

Date: 17.MAR.2008 16:50:13

Conducted Output Power Plot on Configuration IEEE 802.11 a Ant. 1-2 / 5300 MHz



Date: 17.MAR.2008 16:51:56

Conducted Output Power Plot on Configuration IEEE 802.11 a Ant. 1-3 / 5300 MHz

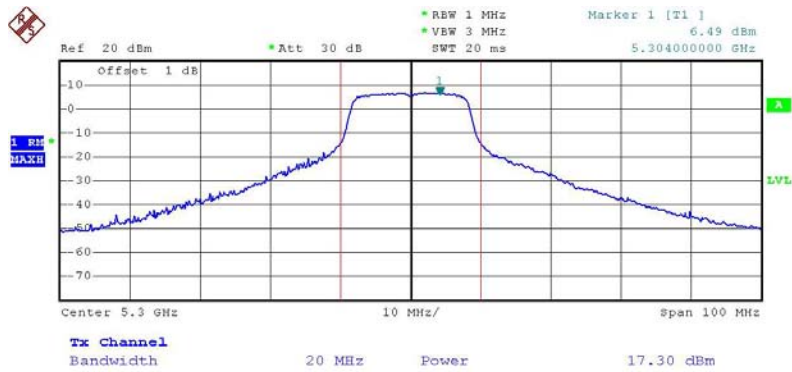

Date: 17.MAR.2008 16:54:17

Conducted Output Power Plot on Configuration IEEE 802.11 a Ant. 1-1 / 5320 MHz

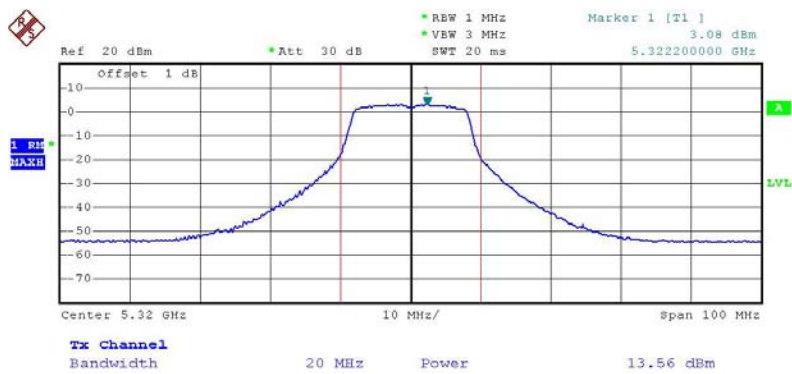

Date: 17.MAR.2008 16:57:34

Conducted Output Power Plot on Configuration IEEE 802.11 a Ant. 1-2 / 5320 MHz

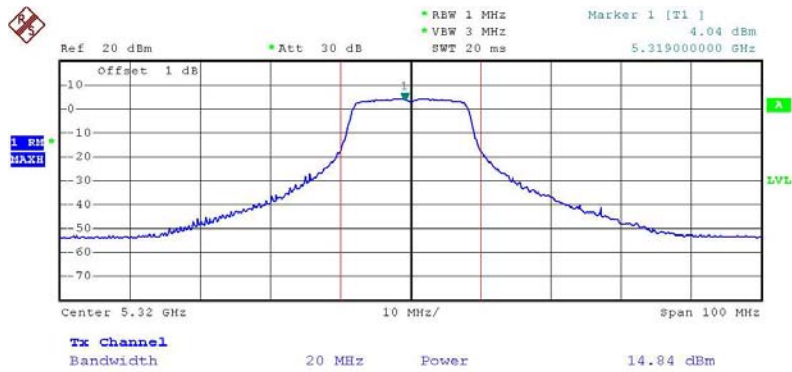

Date: 17.MAR.2008 16:56:44

Conducted Output Power Plot on Configuration IEEE 802.11 a Ant. 1-3 / 5320 MHz

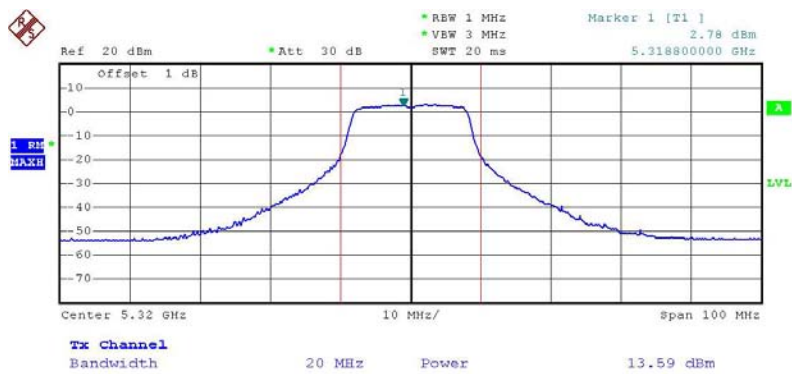

Date: 17.MAR.2008 16:55:50

Conducted Output Power Plot on Configuration IEEE 802.11 a Ant. 1-1 / 5500 MHz

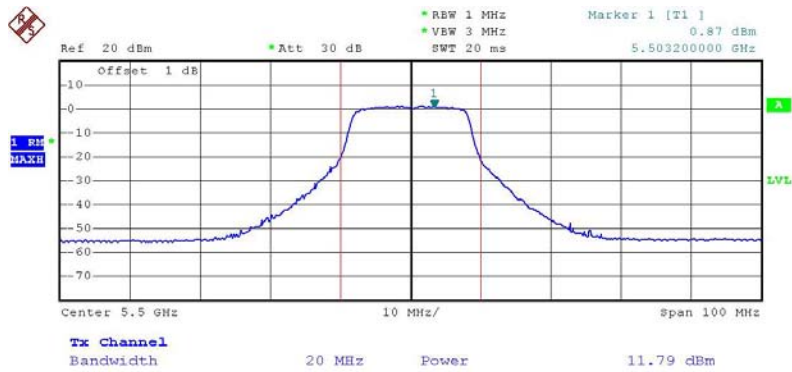

Date: 17.MAR.2008 16:58:36

Conducted Output Power Plot on Configuration IEEE 802.11 a Ant. 1-2 / 5500 MHz

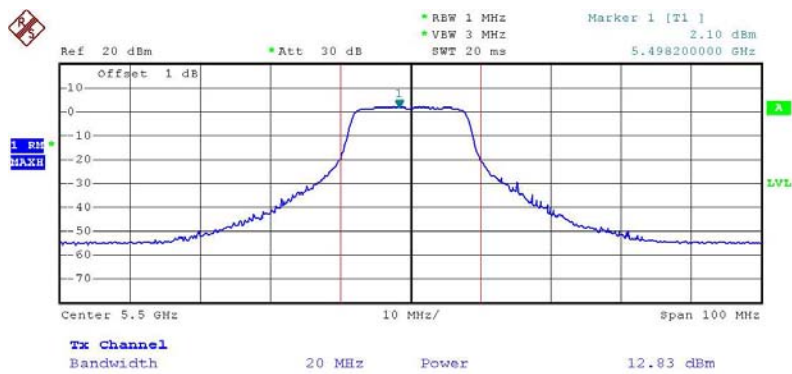

Date: 17.MAR.2008 16:59:28

Conducted Output Power Plot on Configuration IEEE 802.11 a Ant. 1-3 / 5500 MHz

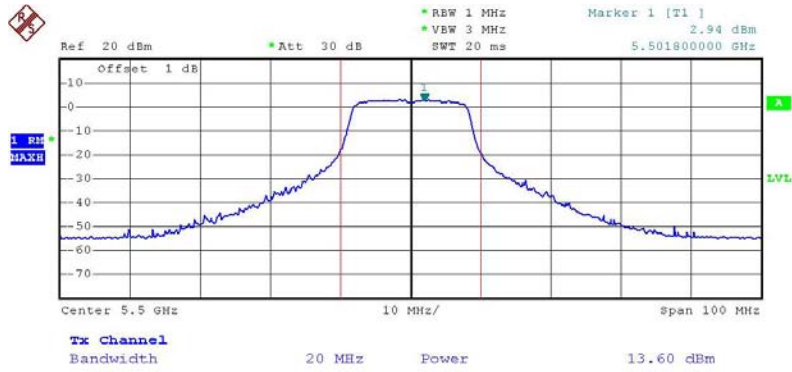

Date: 17.MAR.2008 17:00:15

Conducted Output Power Plot on Configuration IEEE 802.11 a Ant. 1-1 / 5580 MHz

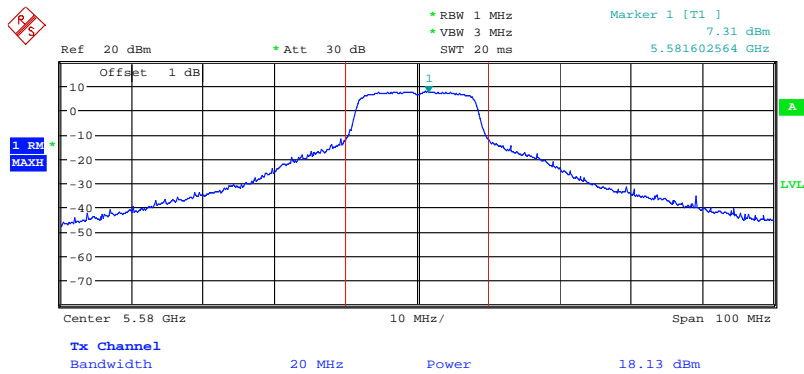

Date: 20.MAR.2008 18:55:53

Conducted Output Power Plot on Configuration IEEE 802.11 a Ant. 1-2 / 5580 MHz

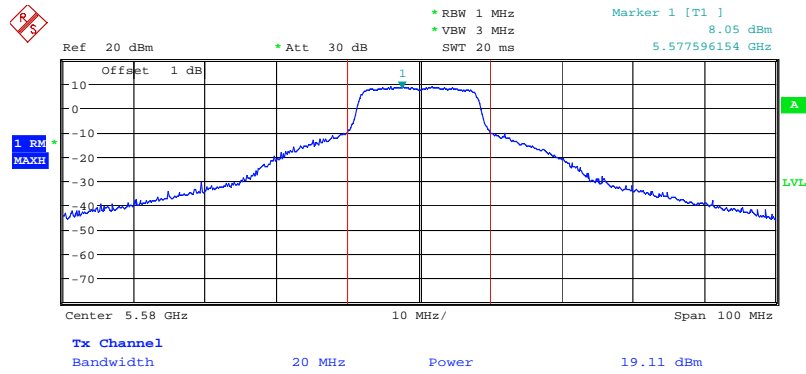

Date: 20.MAR.2008 18:56:35

Conducted Output Power Plot on Configuration IEEE 802.11 a Ant. 1-3 / 5580 MHz

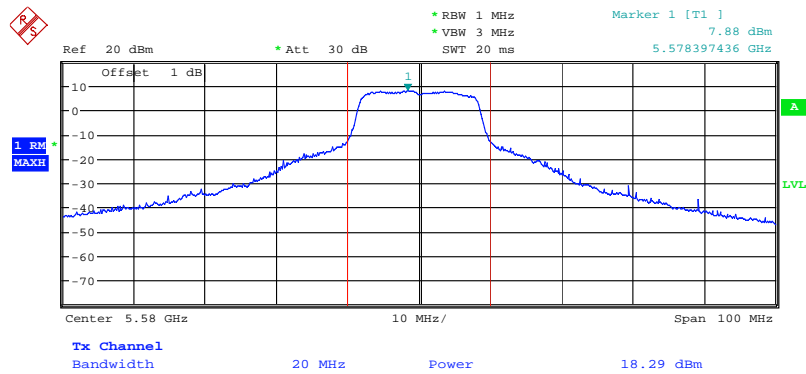

Date: 20.MAR.2008 18:57:52

Conducted Output Power Plot on Configuration IEEE 802.11 a Ant. 1-1 / 5700 MHz

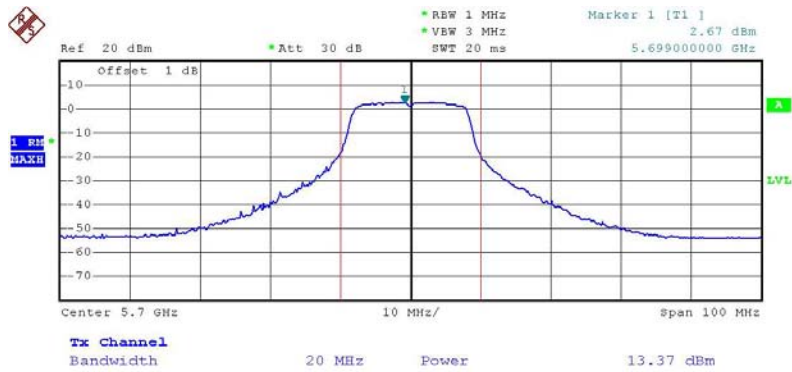

Date: 17.MAR.2008 17:04:47

Conducted Output Power Plot on Configuration IEEE 802.11 a Ant. 1-2 / 5700 MHz

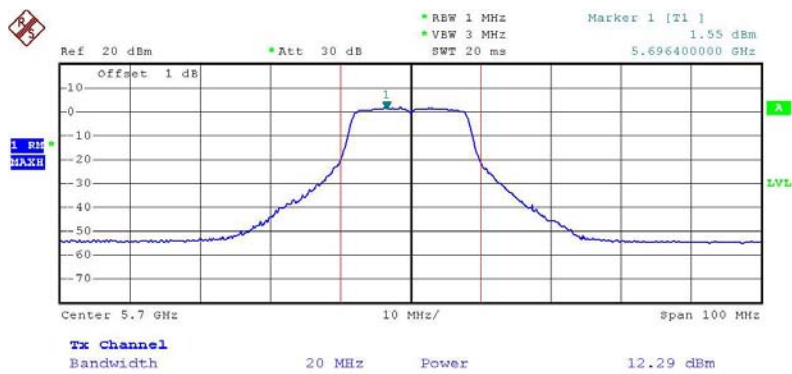

Date: 17.MAR.2008 17:05:52

Conducted Output Power Plot on Configuration IEEE 802.11 a Ant. 1-3 / 5700 MHz

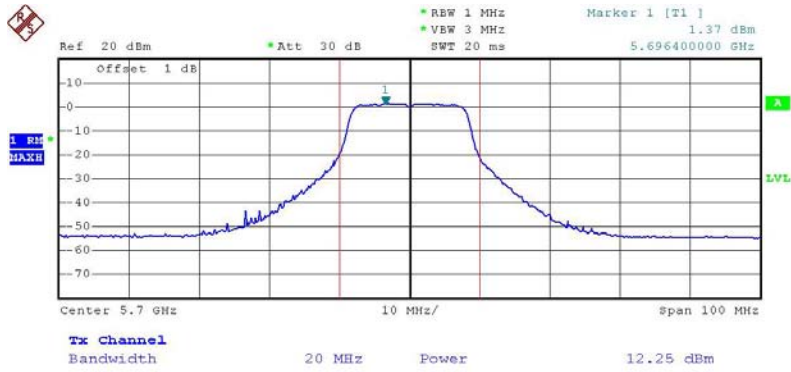

Date: 17.MAR.2008 17:06:40

Conducted Output Power Plot on Configuration IEEE 802.11 a Ant. 5-3 / 5180 MHz

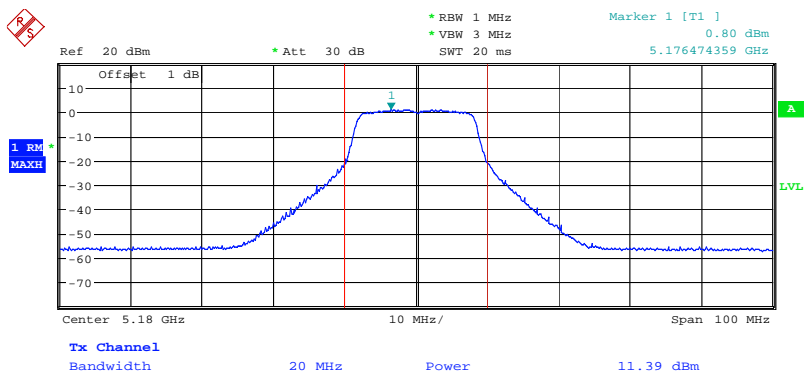

Date: 20.MAR.2008 18:37:06

Conducted Output Power Plot on Configuration IEEE 802.11 a Ant. 5-1 / 5260 MHz

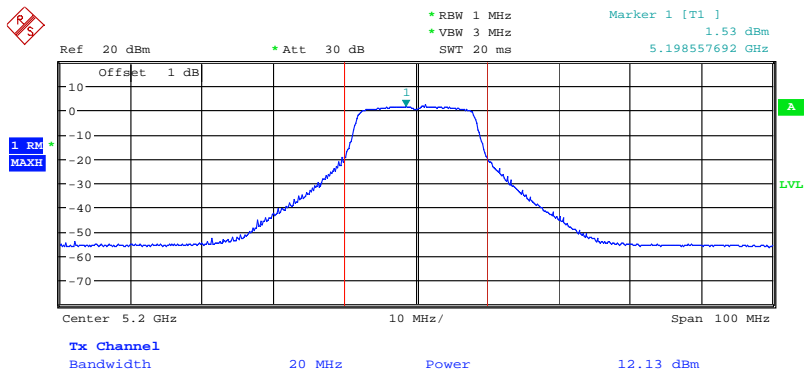

Date: 20.MAR.2008 18:40:02

Conducted Output Power Plot on Configuration IEEE 802.11 a Ant. 5-2 / 5260 MHz

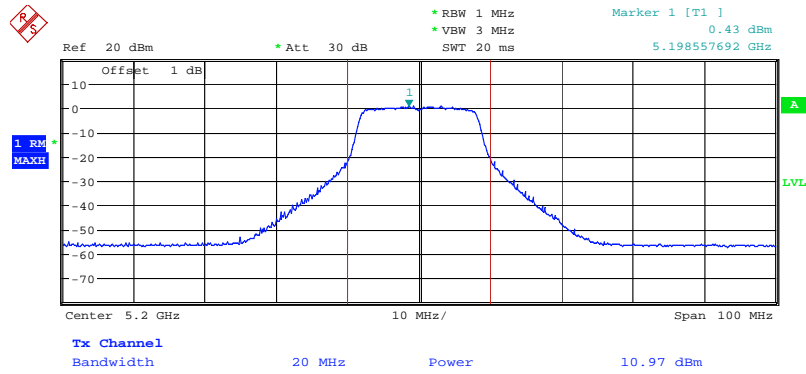

Date: 20.MAR.2008 18:38:52

Conducted Output Power Plot on Configuration IEEE 802.11 a Ant. 5-3 / 5260 MHz

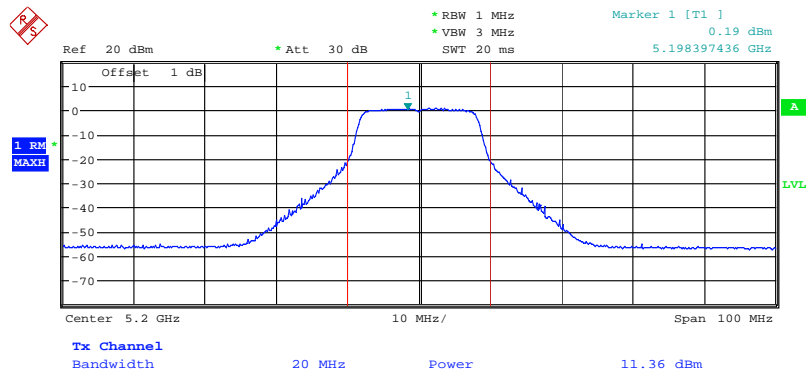

Date: 20.MAR.2008 18:37:59

Conducted Output Power Plot on Configuration IEEE 802.11 a Ant. 5-3 / 5240 MHz

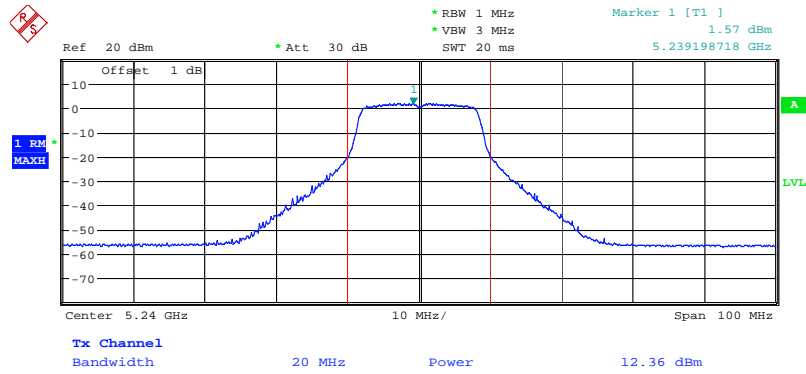

Date: 20.MAR.2008 18:43:10

Conducted Output Power Plot on Configuration IEEE 802.11 a Ant. 5-1 / 5260 MHz

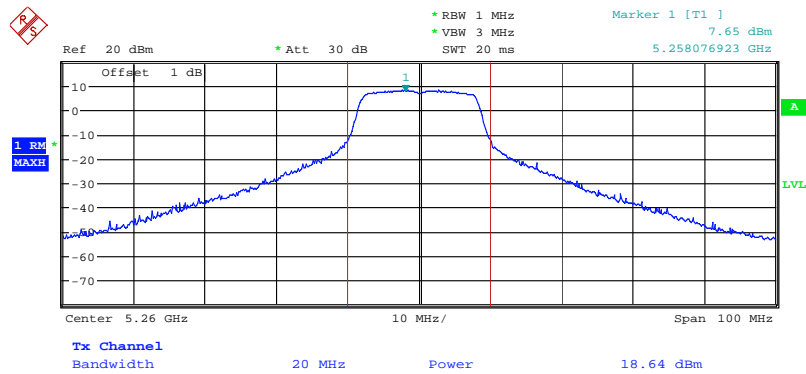

Date: 20.MAR.2008 18:50:43

Conducted Output Power Plot on Configuration IEEE 802.11 a Ant. 5-2 / 5260 MHz

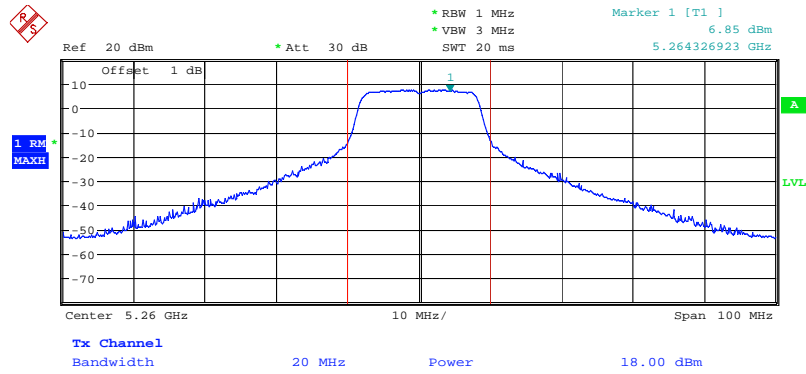

Date: 20.MAR.2008 18:49:21

Conducted Output Power Plot on Configuration IEEE 802.11 a Ant. 5-3 / 5260 MHz

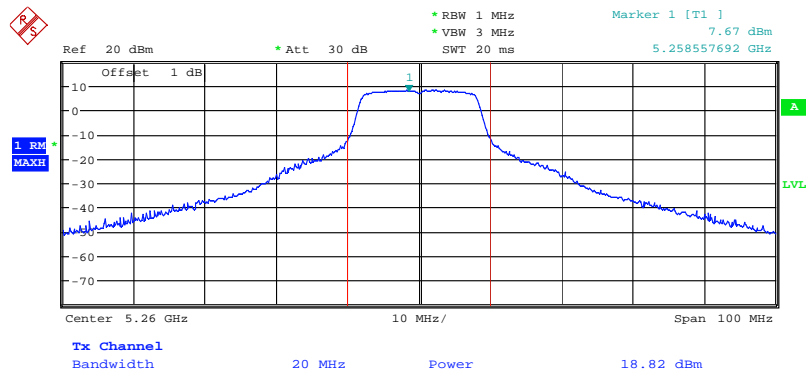

Date: 20.MAR.2008 18:48:23

Conducted Output Power Plot on Configuration IEEE 802.11 a Ant. 5-1 / 5300 MHz

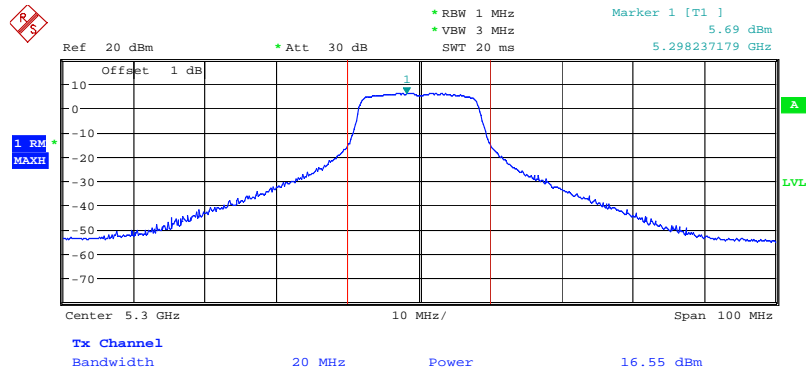

Date: 21.MAR.2008 13:37:40

Conducted Output Power Plot on Configuration IEEE 802.11 a Ant. 5-2 / 5300 MHz

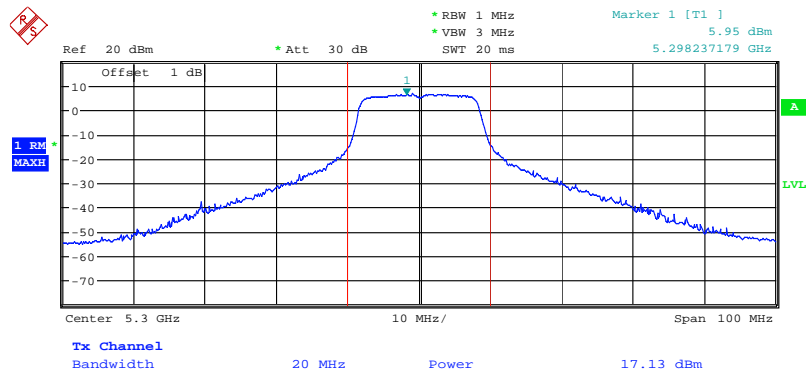

Date: 21.MAR.2008 13:38:50

Conducted Output Power Plot on Configuration IEEE 802.11 a Ant. 5-3 / 5300 MHz

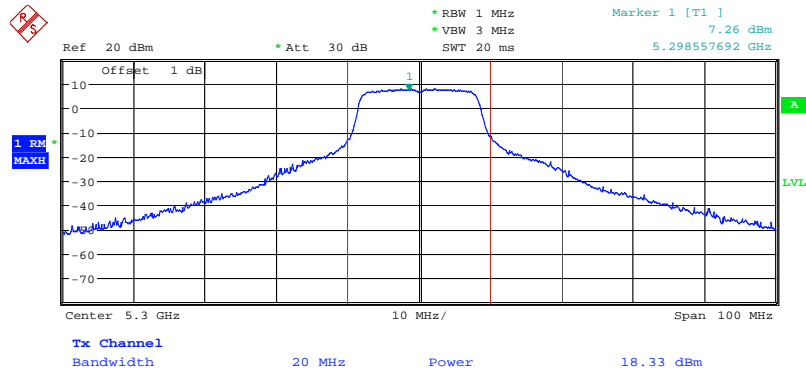

Date: 21.MAR.2008 13:39:49

Conducted Output Power Plot on Configuration IEEE 802.11 a Ant. 5-1 / 5320 MHz

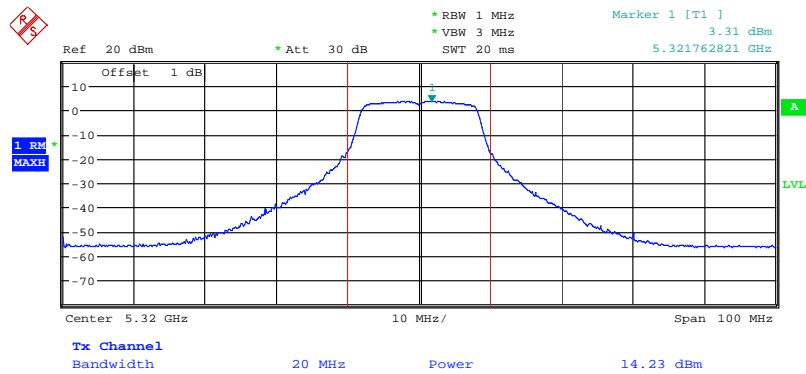

Date: 21.MAR.2008 13:43:07

Conducted Output Power Plot on Configuration IEEE 802.11 a Ant. 5-2 / 5320 MHz

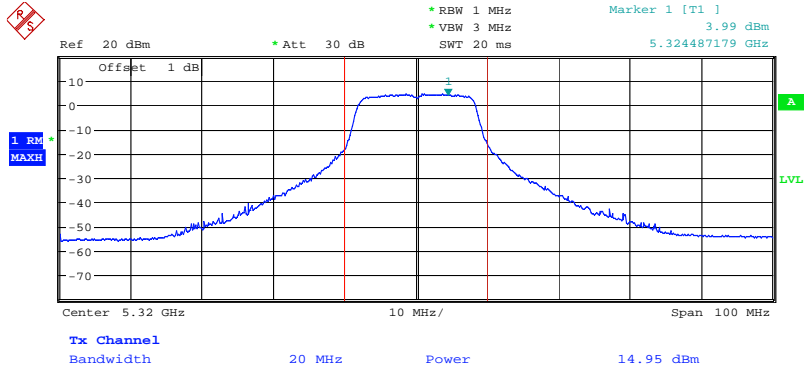

Date: 21.MAR.2008 13:42:16

Conducted Output Power Plot on Configuration IEEE 802.11 a Ant. 5-3 / 5320 MHz

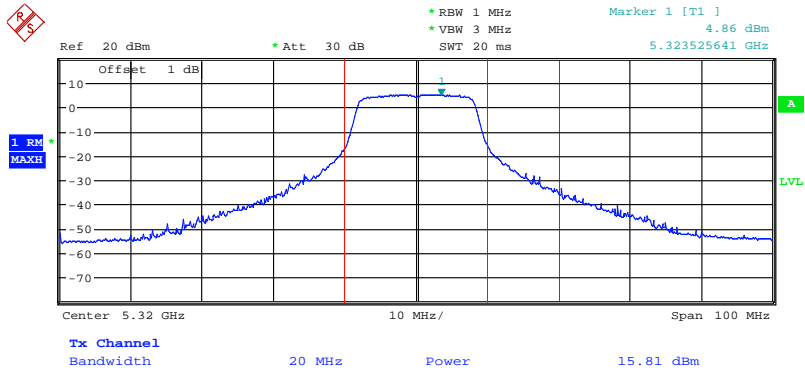

Date: 21.MAR.2008 13:41:22

Conducted Output Power Plot on Configuration IEEE 802.11 a Ant. 5-1 / 5500 MHz

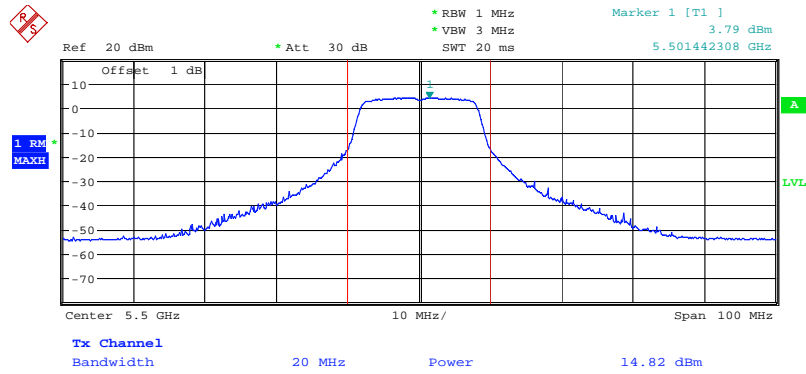

Date: 21.MAR.2008 13:50:09

Conducted Output Power Plot on Configuration IEEE 802.11 a Ant. 5-2 / 5500 MHz

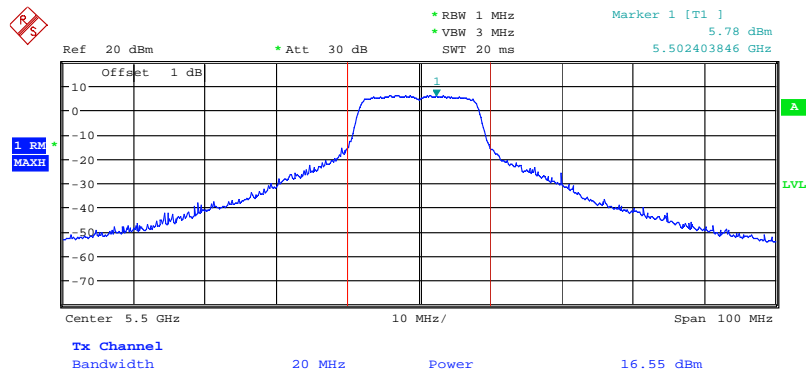

Date: 21.MAR.2008 13:50:45

Conducted Output Power Plot on Configuration IEEE 802.11 a Ant. 5-3 / 5500 MHz

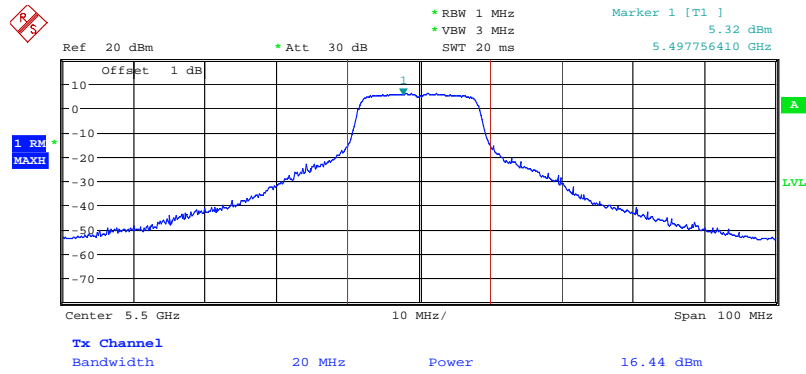

Date: 21.MAR.2008 13:52:17

Conducted Output Power Plot on Configuration IEEE 802.11 a Ant. 5-1 / 5580 MHz

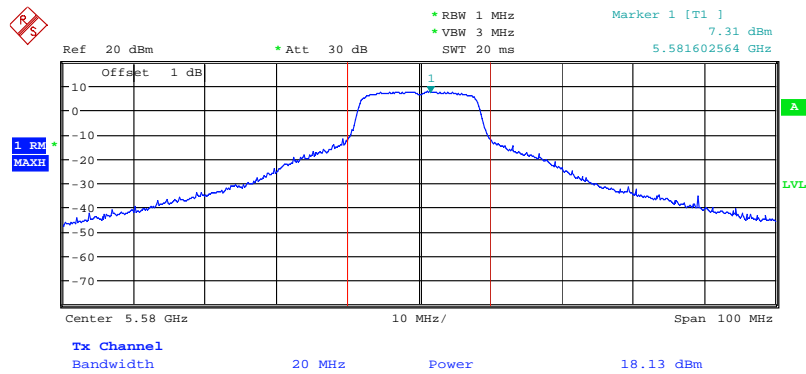

Date: 20.MAR.2008 18:55:53

Conducted Output Power Plot on Configuration IEEE 802.11 a Ant. 5-2 / 5580 MHz

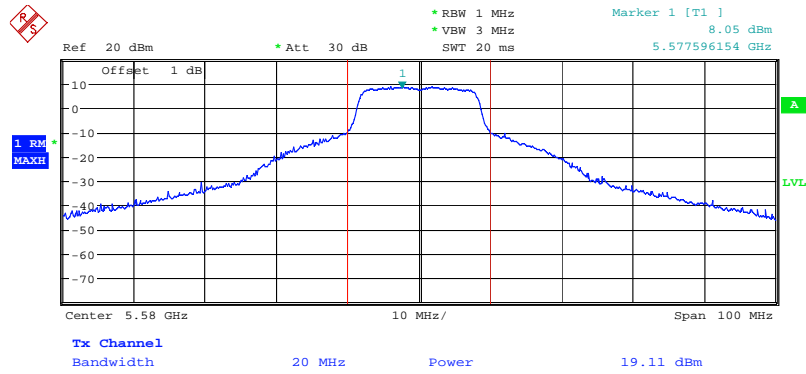

Date: 20.MAR.2008 18:56:35

Conducted Output Power Plot on Configuration IEEE 802.11 a Ant. 5-3 / 5580 MHz

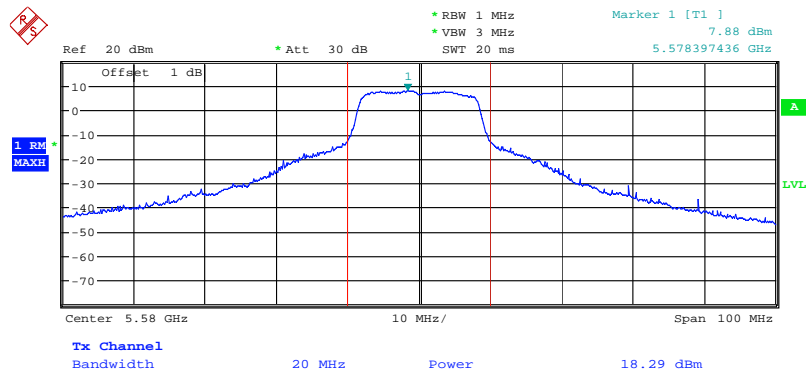

Date: 20.MAR.2008 18:57:52

Conducted Output Power Plot on Configuration IEEE 802.11 a Ant. 5-3 / 5700 MHz

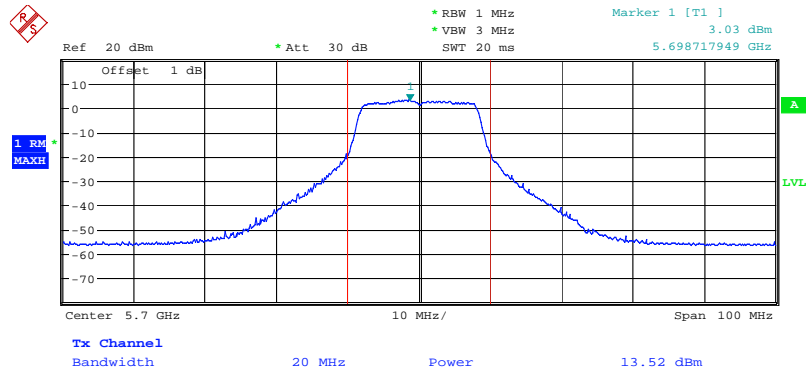

Date: 21.MAR.2008 13:53:24

Conducted Output Power Plot on Configuration IEEE 802.11 a Ant. 6-1 / 5180 MHz

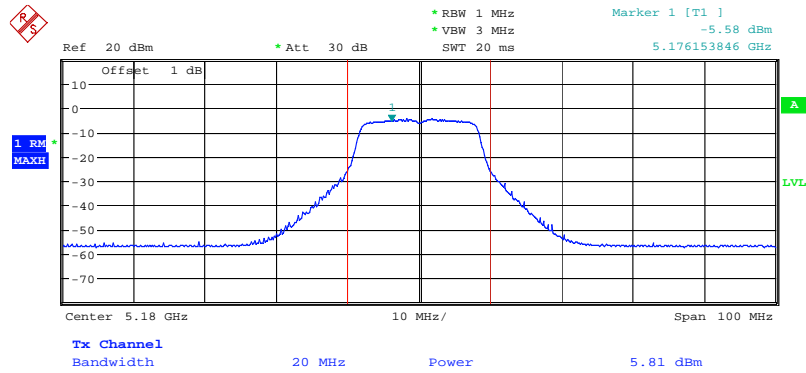

Date: 25.MAR.2008 08:56:43

Conducted Output Power Plot on Configuration IEEE 802.11 a Ant. 6-2 / 5180 MHz

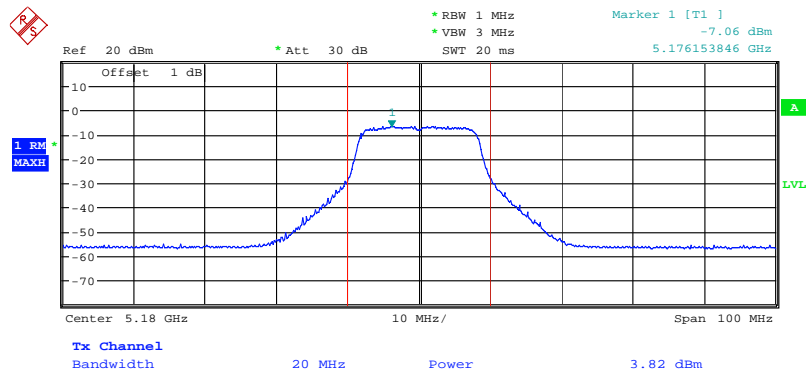

Date: 25.MAR.2008 08:56:10

Conducted Output Power Plot on Configuration IEEE 802.11 a Ant. 6-3 / 5180 MHz

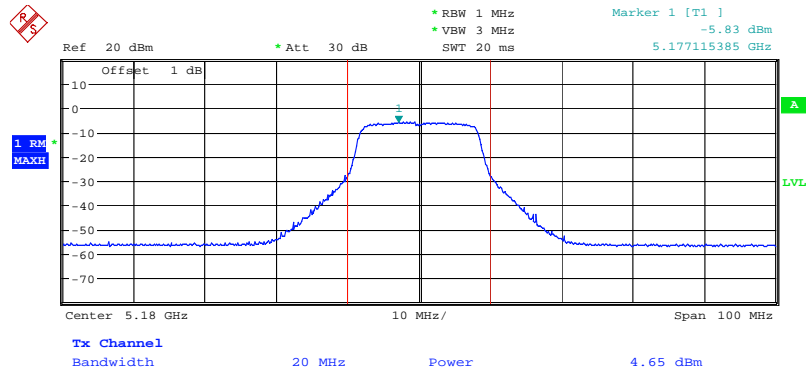

Date: 25.MAR.2008 08:55:06

Conducted Output Power Plot on Configuration IEEE 802.11 a Ant. 6-1 / 5260 MHz

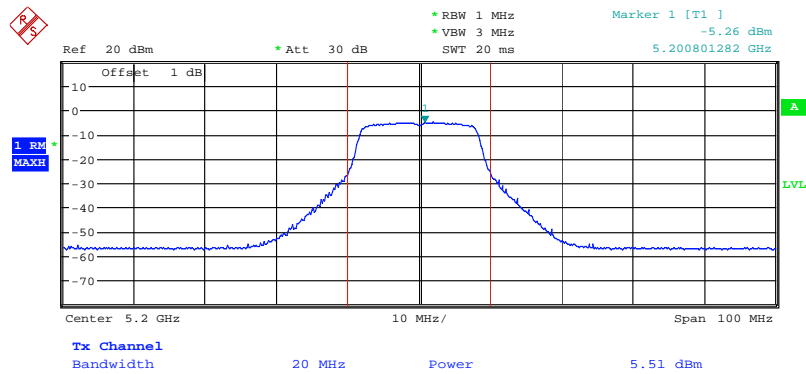

Date: 25.MAR.2008 08:57:27

Conducted Output Power Plot on Configuration IEEE 802.11 a Ant. 6-2 / 5260 MHz

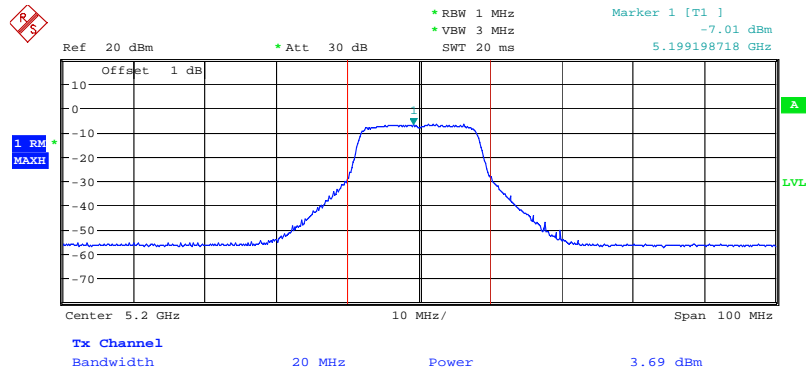

Date: 25.MAR.2008 08:58:06

Conducted Output Power Plot on Configuration IEEE 802.11 a Ant. 6-3 / 5260 MHz

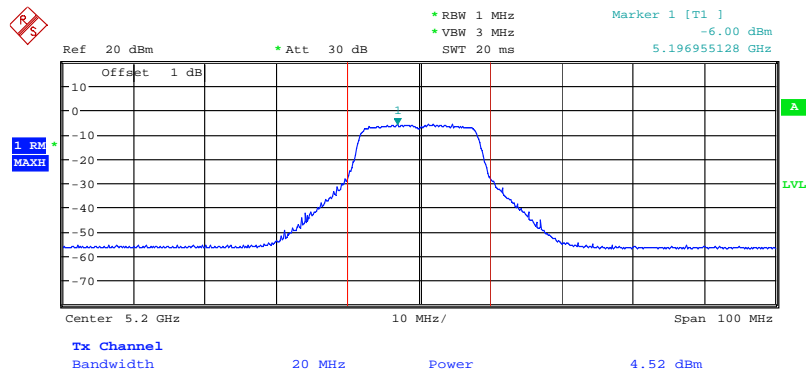

Date: 25.MAR.2008 08:59:02

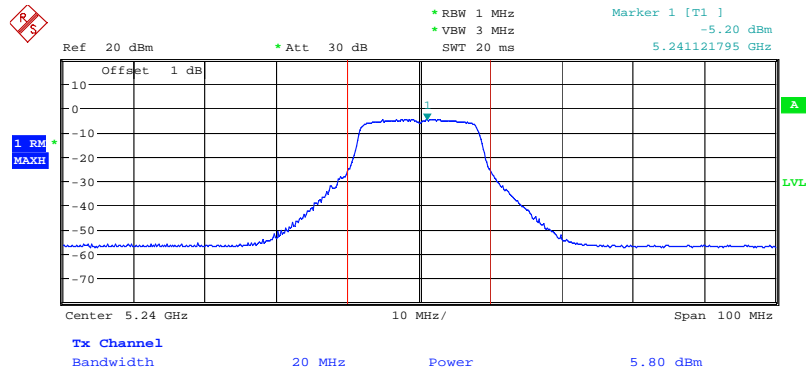
Conducted Output Power Plot on Configuration IEEE 802.11 a Ant. 6-1 / 5240 MHz

Date: 25.MAR.2008 09:00:57

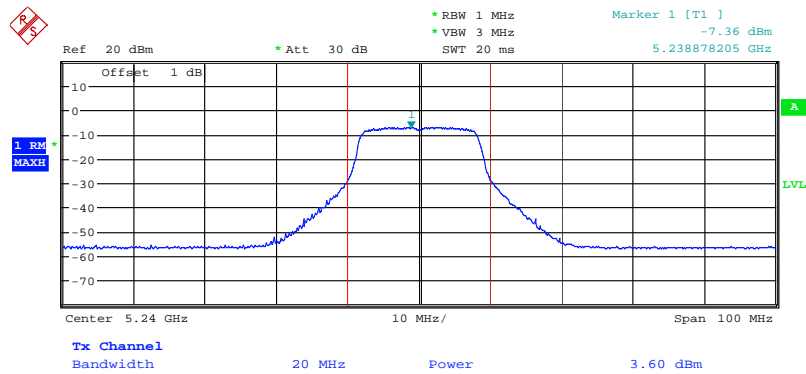
Conducted Output Power Plot on Configuration IEEE 802.11 a Ant. 6-2 / 5240 MHz

Date: 25.MAR.2008 09:01:34

Conducted Output Power Plot on Configuration IEEE 802.11 a Ant. 6-3 / 5240 MHz

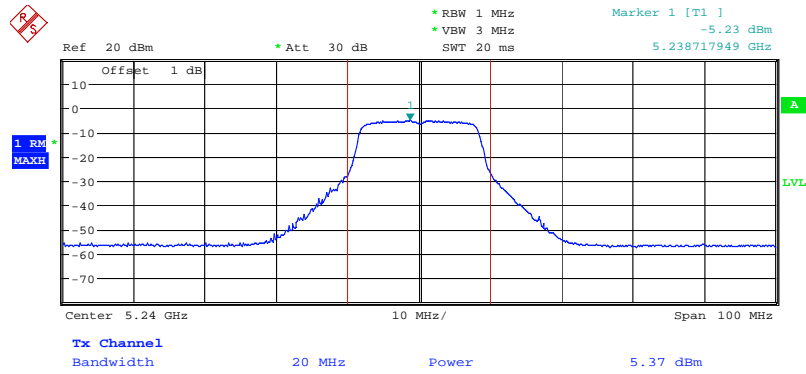

Date: 25.MAR.2008 09:02:01

Conducted Output Power Plot on Configuration IEEE 802.11 a Ant. 6-1 / 5260 MHz

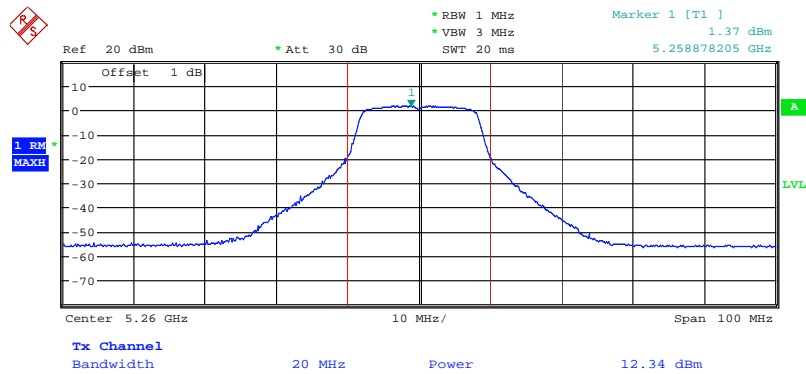

Date: 25.MAR.2008 09:05:32

Conducted Output Power Plot on Configuration IEEE 802.11 a Ant. 6-2 / 5260 MHz

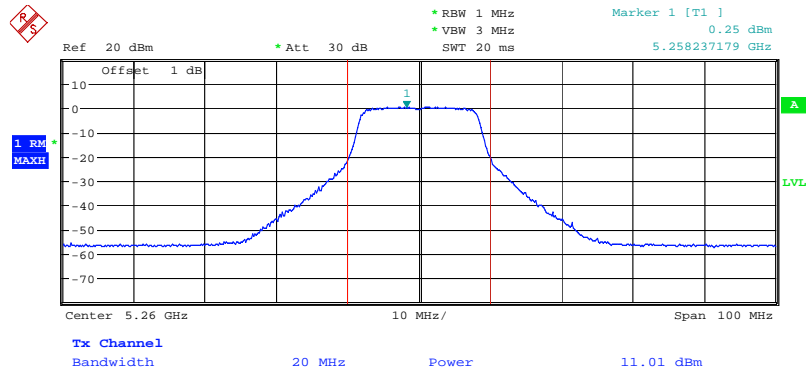

Date: 25.MAR.2008 09:05:55

Conducted Output Power Plot on Configuration IEEE 802.11 a Ant. 6-3 / 5260 MHz

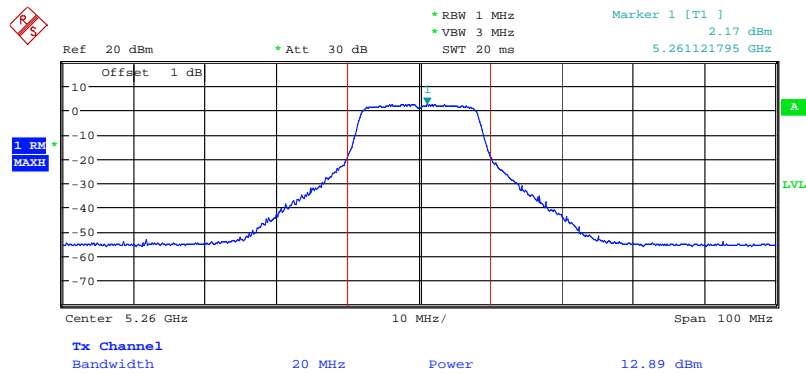

Date: 25.MAR.2008 09:06:28

Conducted Output Power Plot on Configuration IEEE 802.11 a Ant. 6-1 / 5300 MHz

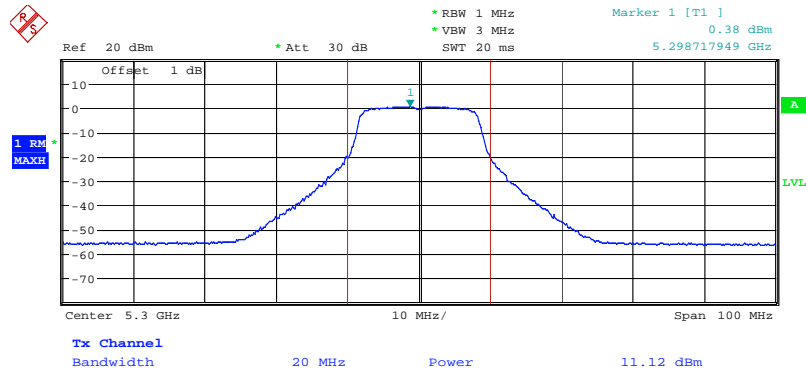

Date: 25.MAR.2008 09:17:03

Conducted Output Power Plot on Configuration IEEE 802.11 a Ant. 6-2 / 5300 MHz

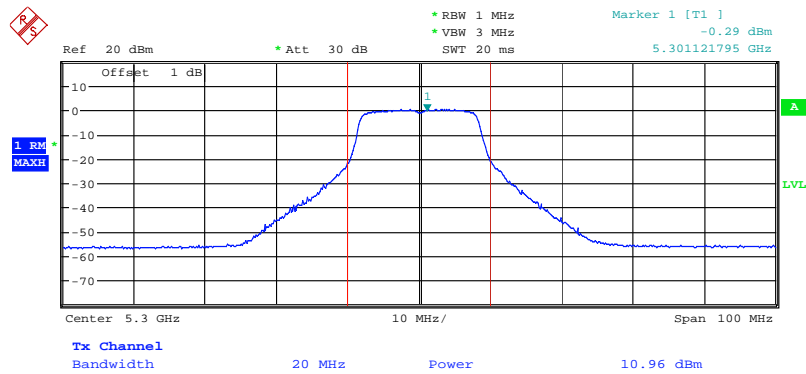

Date: 25.MAR.2008 09:17:50

Conducted Output Power Plot on Configuration IEEE 802.11 a Ant. 6-3 / 5300 MHz

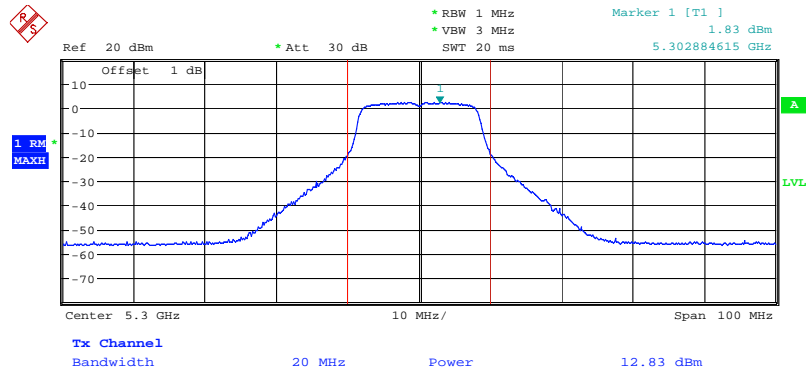

Date: 25.MAR.2008 09:18:56

Conducted Output Power Plot on Configuration IEEE 802.11 a Ant. 6-1 / 5320 MHz

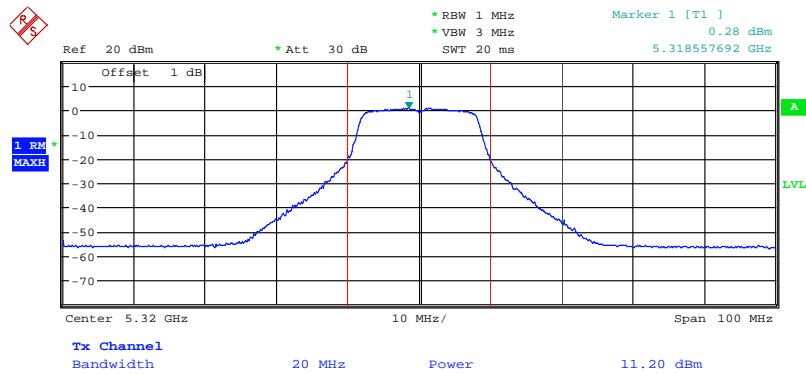

Date: 25.MAR.2008 09:21:57

Conducted Output Power Plot on Configuration IEEE 802.11 a Ant. 6-2 / 5320 MHz

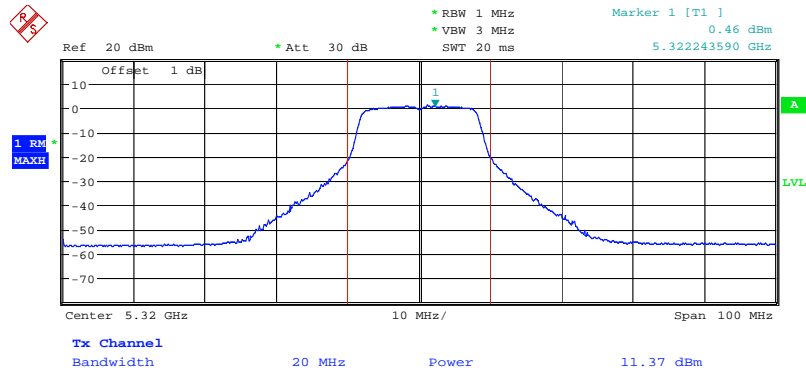

Date: 25.MAR.2008 09:20:57

Conducted Output Power Plot on Configuration IEEE 802.11 a Ant. 6-3 / 5320 MHz

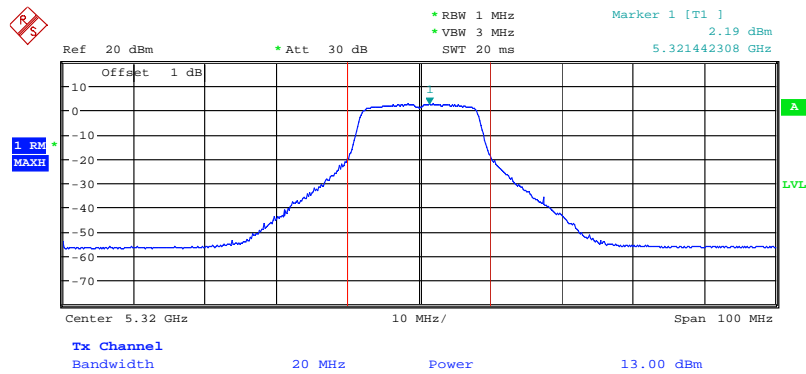

Date: 25.MAR.2008 09:20:30

Conducted Output Power Plot on Configuration IEEE 802.11 a Ant. 6-1 / 5500 MHz

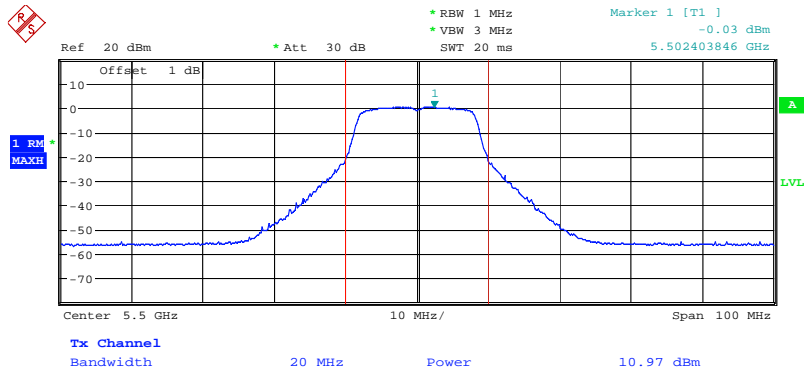

Date: 25.MAR.2008 09:31:00

Conducted Output Power Plot on Configuration IEEE 802.11 a Ant. 6-2 / 5500 MHz

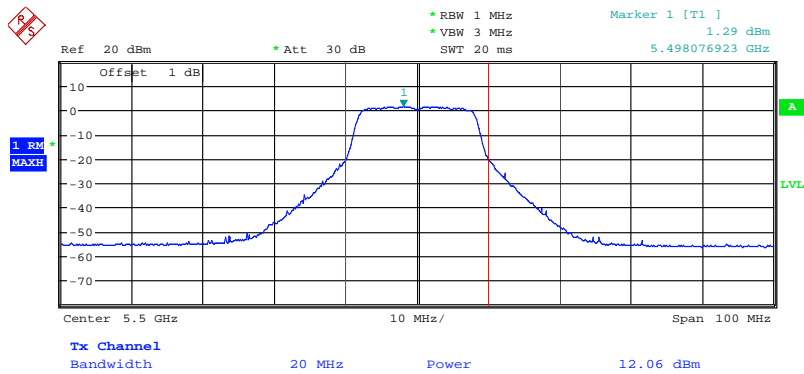

Date: 25.MAR.2008 09:32:58

Conducted Output Power Plot on Configuration IEEE 802.11 a Ant. 6-3 / 5500 MHz

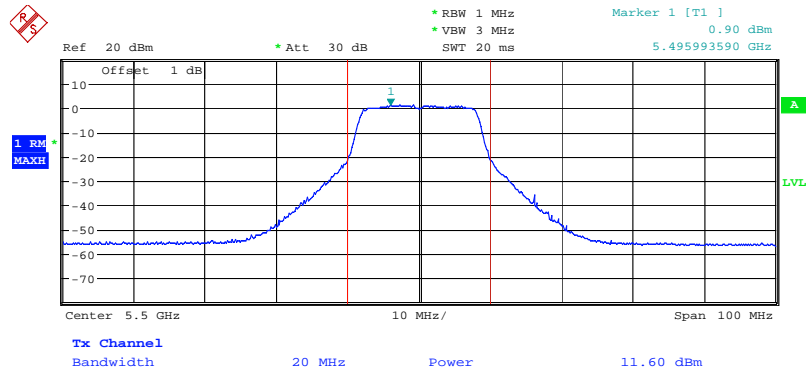

Date: 25.MAR.2008 09:32:08

Conducted Output Power Plot on Configuration IEEE 802.11 a Ant. 6-1 / 5580 MHz

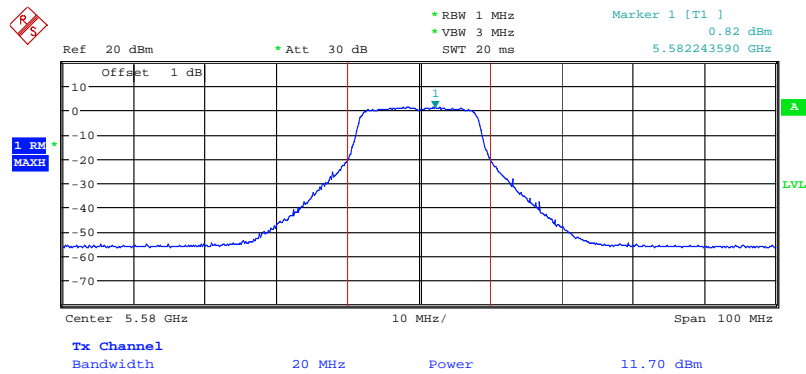

Date: 25.MAR.2008 09:35:12

Conducted Output Power Plot on Configuration IEEE 802.11 a Ant. 6-2 / 5580 MHz

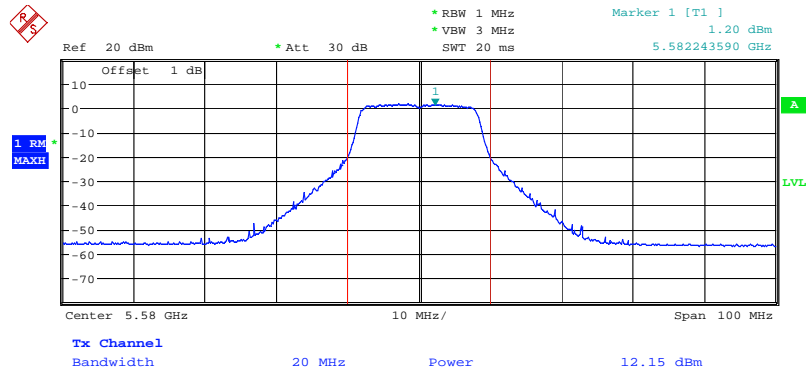

Date: 25.MAR.2008 09:33:56

Conducted Output Power Plot on Configuration IEEE 802.11 a Ant. 6-3 / 5580 MHz

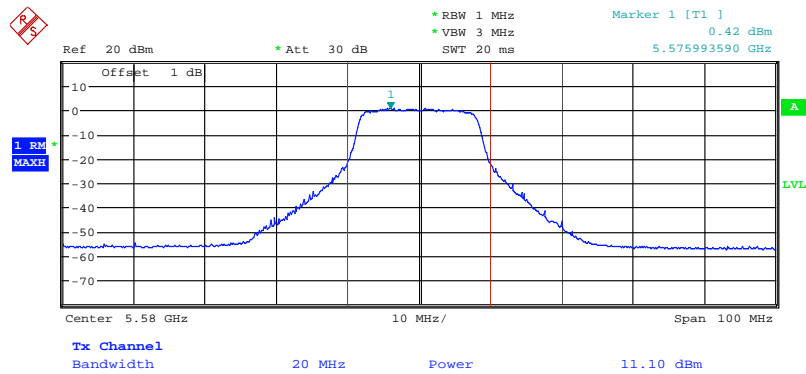

Date: 25.MAR.2008 09:34:24

Conducted Output Power Plot on Configuration IEEE 802.11 a Ant. 6-1 / 5700 MHz

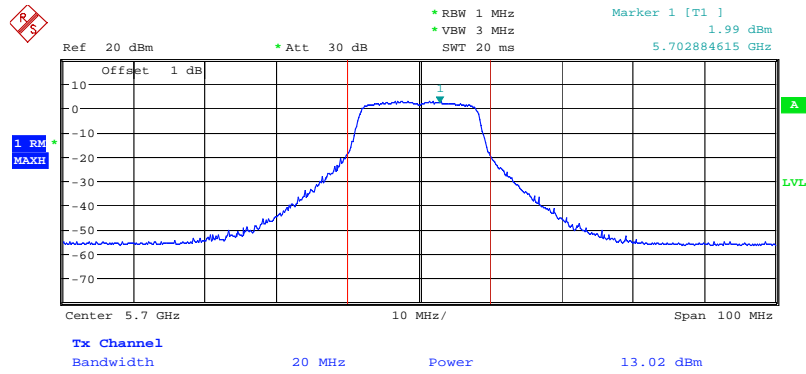

Date: 25.MAR.2008 09:42:54

Conducted Output Power Plot on Configuration IEEE 802.11 a Ant. 6-2 / 5700 MHz

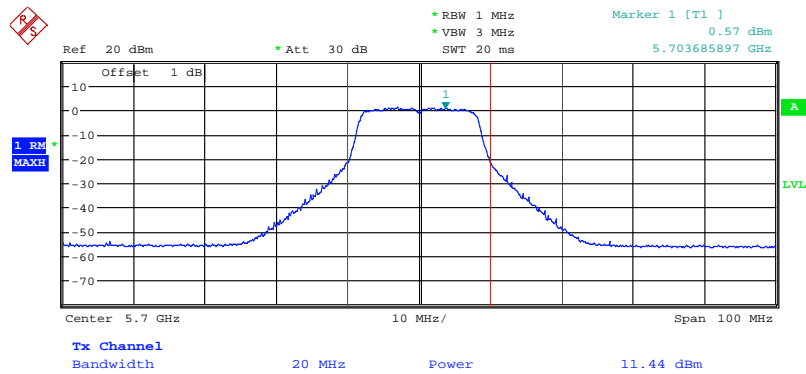

Date: 25.MAR.2008 09:42:06

Conducted Output Power Plot on Configuration IEEE 802.11 a Ant. 6-3 / 5700 MHz

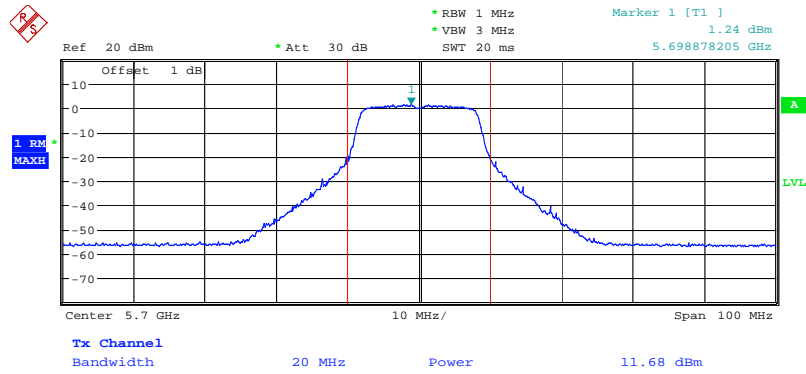

Date: 25.MAR.2008 09:41:06

Conducted Output Power Plot on Configuration IEEE 802.11 a Ant. 7-1 / 5180 MHz

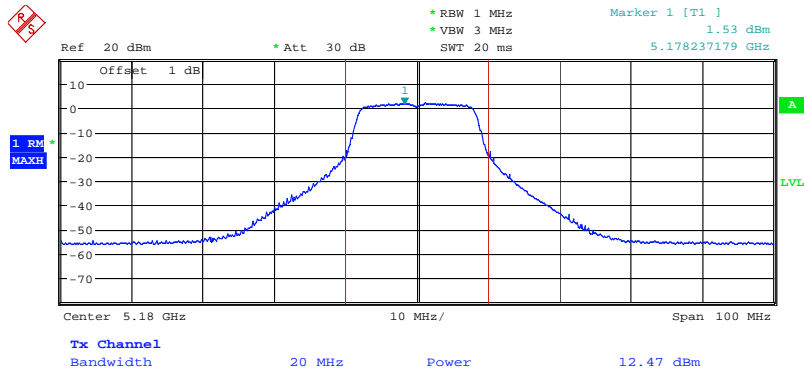

Date: 20.MAR.2008 18:35:55

Conducted Output Power Plot on Configuration IEEE 802.11 a Ant. 7-2 / 5180 MHz

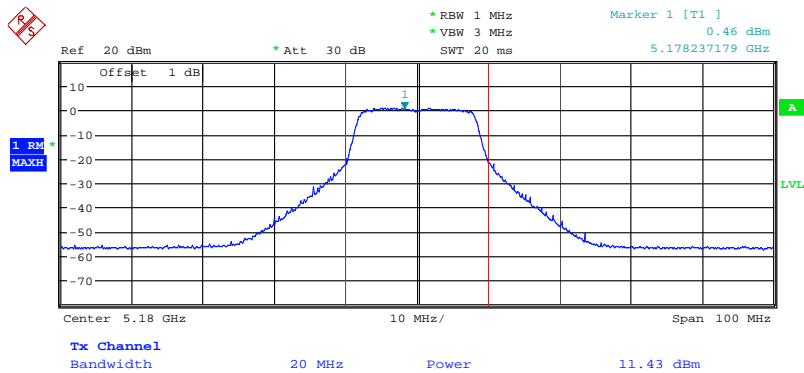

Date: 20.MAR.2008 18:36:32

Conducted Output Power Plot on Configuration IEEE 802.11 a Ant. 7-3 / 5180 MHz

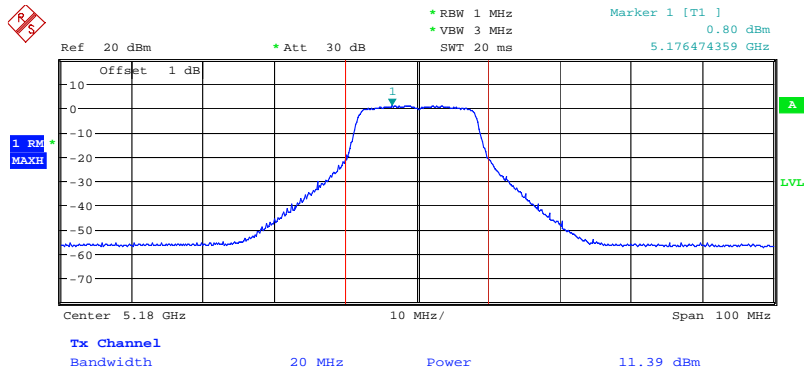

Date: 20.MAR.2008 18:37:06

Conducted Output Power Plot on Configuration IEEE 802.11 a Ant. 7-1 / 5260 MHz

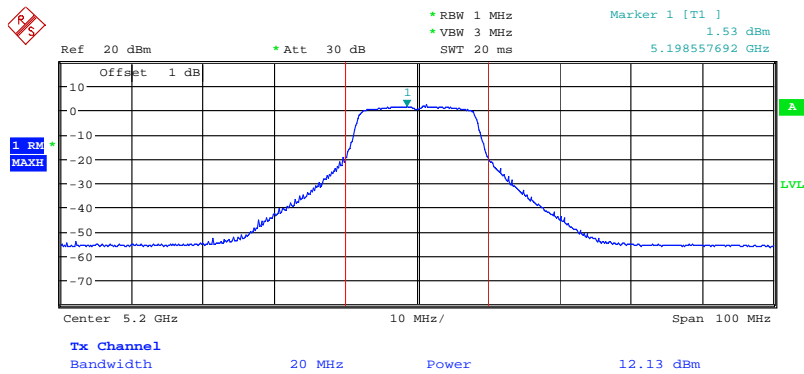

Date: 20.MAR.2008 18:40:02

Conducted Output Power Plot on Configuration IEEE 802.11 a Ant. 7-2 / 5260 MHz

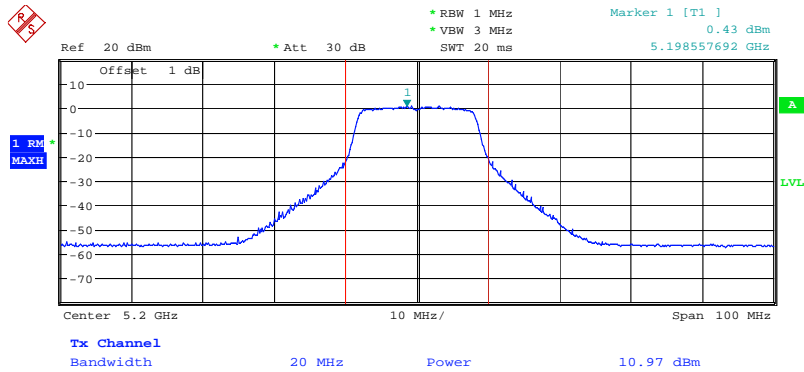

Date: 20.MAR.2008 18:38:52

Conducted Output Power Plot on Configuration IEEE 802.11 a Ant. 7-3 / 5260 MHz

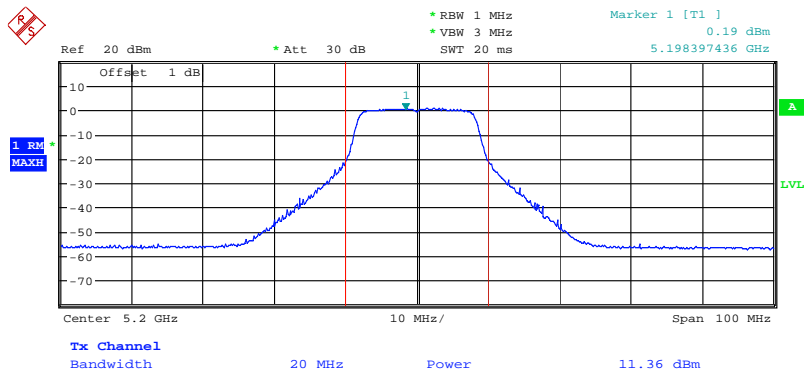

Date: 20.MAR.2008 18:37:59

Conducted Output Power Plot on Configuration IEEE 802.11 a Ant. 7-1 / 5240 MHz

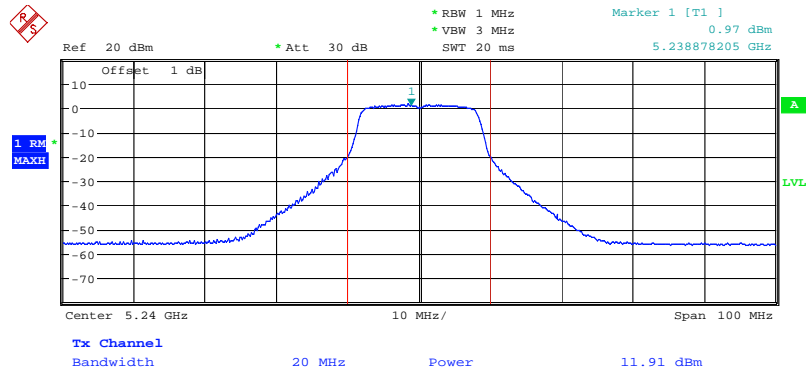

Date: 20.MAR.2008 18:44:25

Conducted Output Power Plot on Configuration IEEE 802.11 a Ant. 7-2 / 5240 MHz

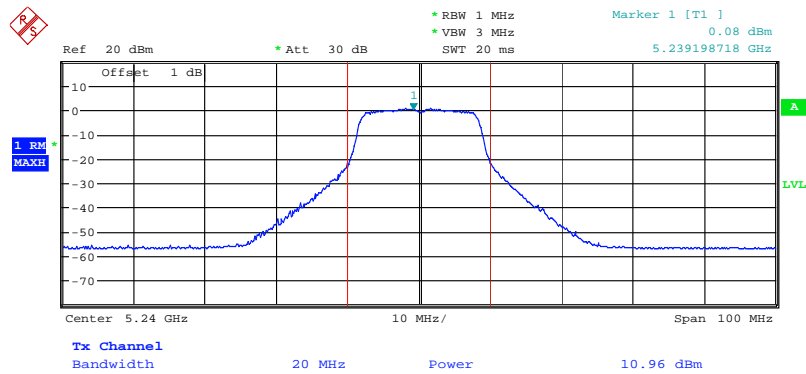

Date: 20.MAR.2008 18:43:44



Conducted Output Power Plot on Configuration IEEE 802.11 a Ant. 7-3 / 5240 MHz

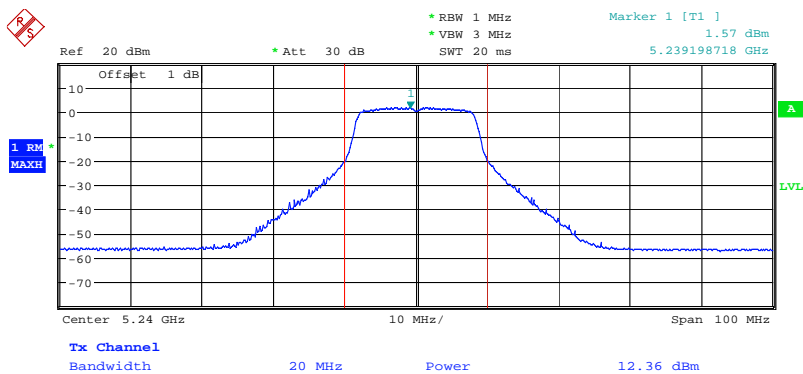

Date: 20.MAR.2008 18:43:10

Conducted Output Power Plot on Configuration IEEE 802.11 a Ant. 7-1 / 5260 MHz

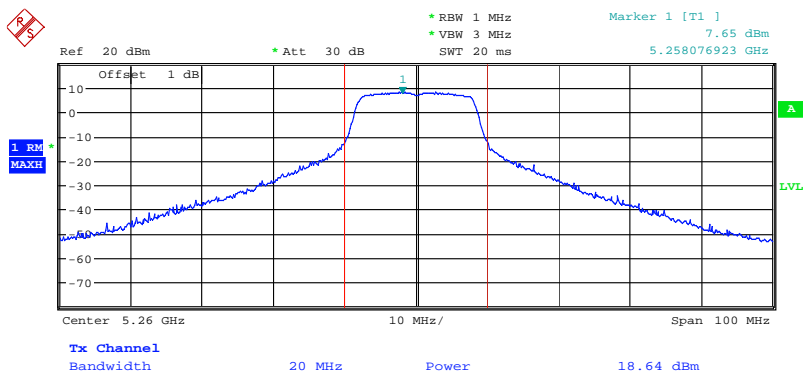

Date: 20.MAR.2008 18:50:43

Conducted Output Power Plot on Configuration IEEE 802.11 a Ant. 7-2 / 5260 MHz

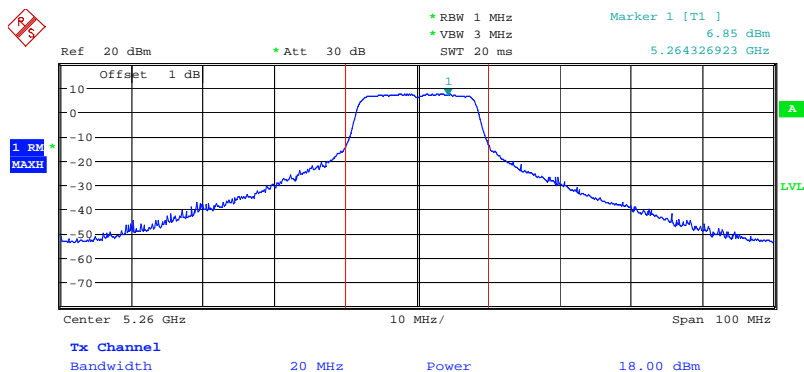

Date: 20.MAR.2008 18:49:21

Conducted Output Power Plot on Configuration IEEE 802.11 a Ant. 7-3 / 5260 MHz

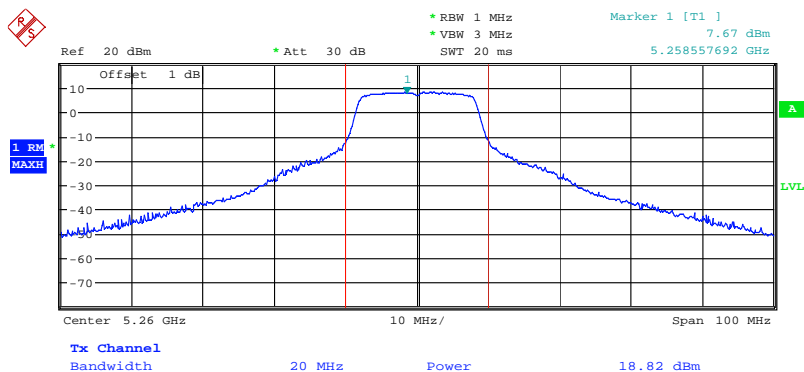

Date: 20.MAR.2008 18:48:23

Conducted Output Power Plot on Configuration IEEE 802.11 a Ant. 7-1 / 5300 MHz

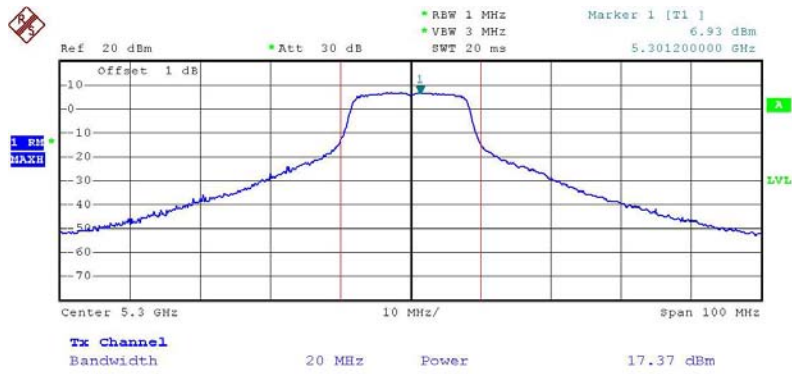

Date: 17.MAR.2008 16:50:13

Conducted Output Power Plot on Configuration IEEE 802.11 a Ant. 7-2 / 5300 MHz

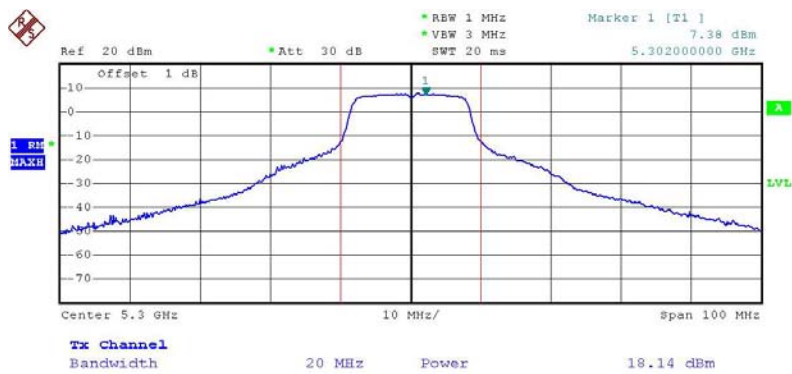

Date: 17.MAR.2008 16:51:56

Conducted Output Power Plot on Configuration IEEE 802.11 a Ant. 7-3 / 5300 MHz

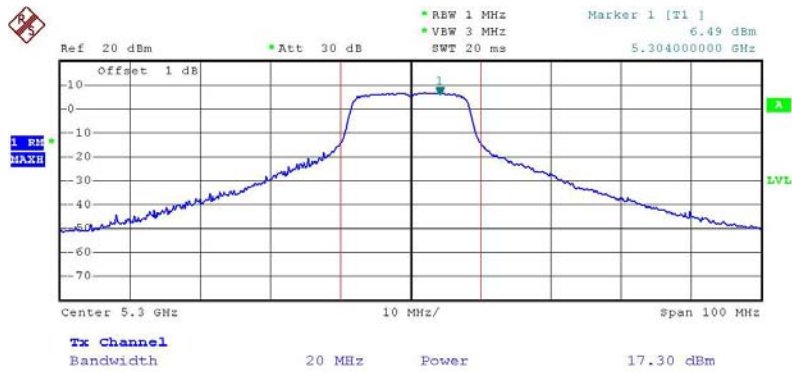

Date: 17.MAR.2008 16:54:17

Conducted Output Power Plot on Configuration IEEE 802.11 a Ant. 7-1 / 5320 MHz

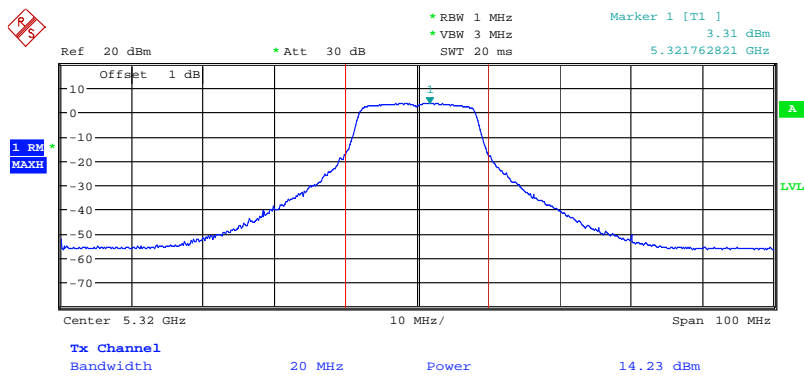

Date: 21.MAR.2008 13:43:07

Conducted Output Power Plot on Configuration IEEE 802.11 a Ant. 7-1 / 5500 MHz

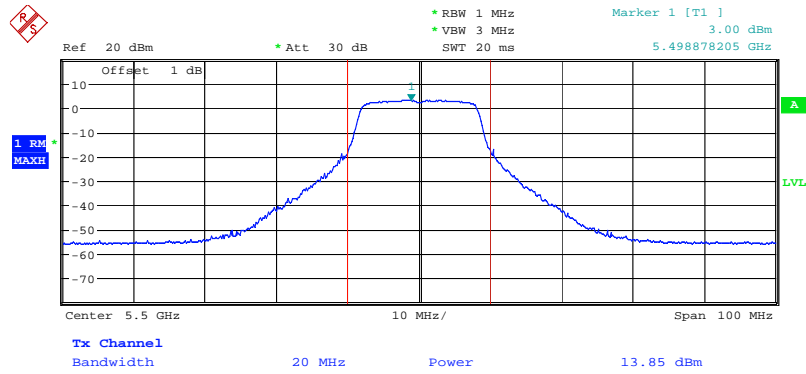

Date: 26.MAR.2008 16:20:57

Conducted Output Power Plot on Configuration IEEE 802.11 a Ant. 7-2 / 5500 MHz

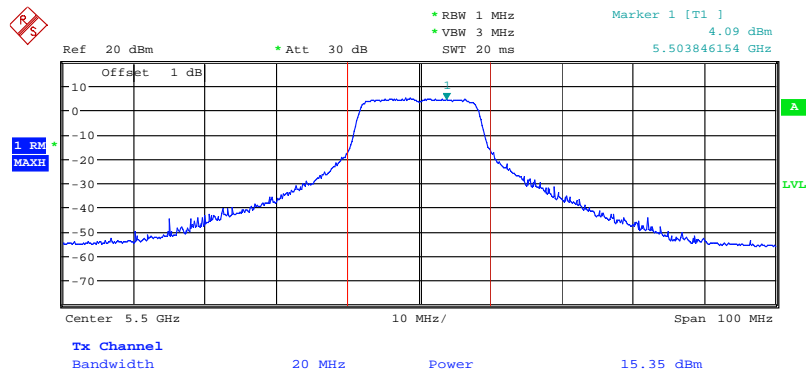

Date: 26.MAR.2008 16:22:06

Conducted Output Power Plot on Configuration IEEE 802.11 a Ant. 7-3 / 5500 MHz

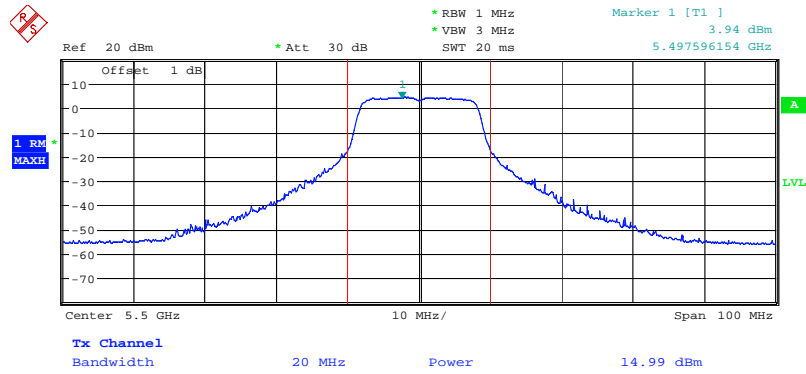

Date: 26.MAR.2008 16:22:47

Conducted Output Power Plot on Configuration IEEE 802.11 a Ant. 7-1 / 5580 MHz

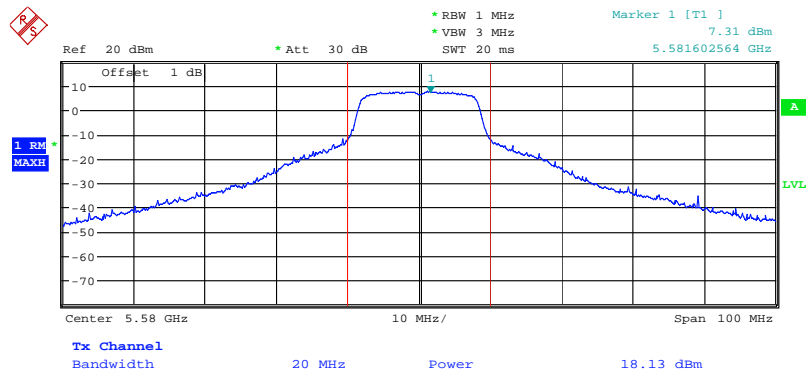

Date: 20.MAR.2008 18:55:53

Conducted Output Power Plot on Configuration IEEE 802.11 a Ant. 7-2 / 5580 MHz

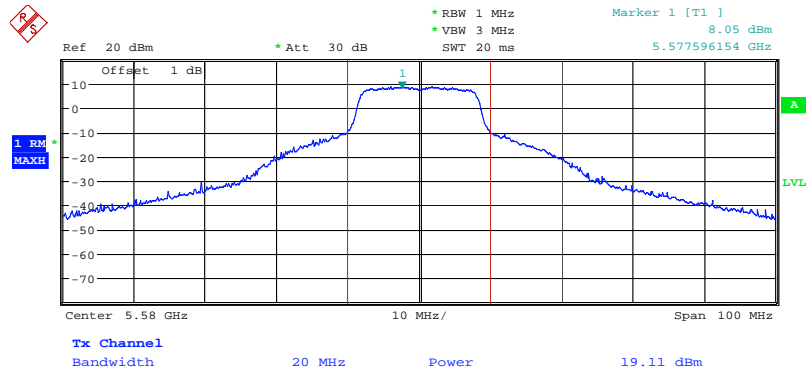

Date: 20.MAR.2008 18:56:35

Conducted Output Power Plot on Configuration IEEE 802.11 a Ant. 7-3 / 5580 MHz

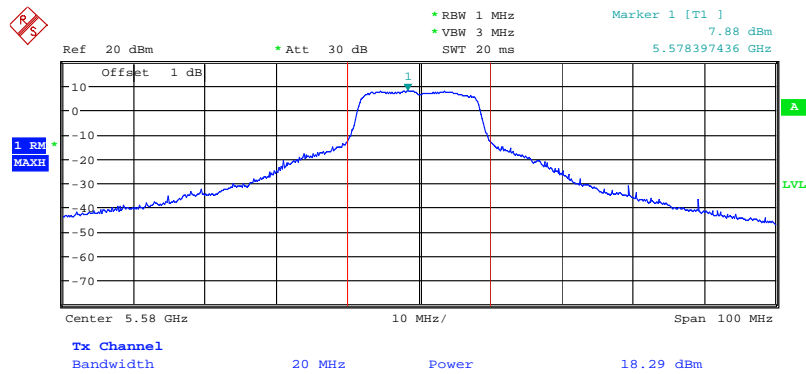

Date: 20.MAR.2008 18:57:52

Conducted Output Power Plot on Configuration IEEE 802.11 a Ant. 7-1 / 5700 MHz

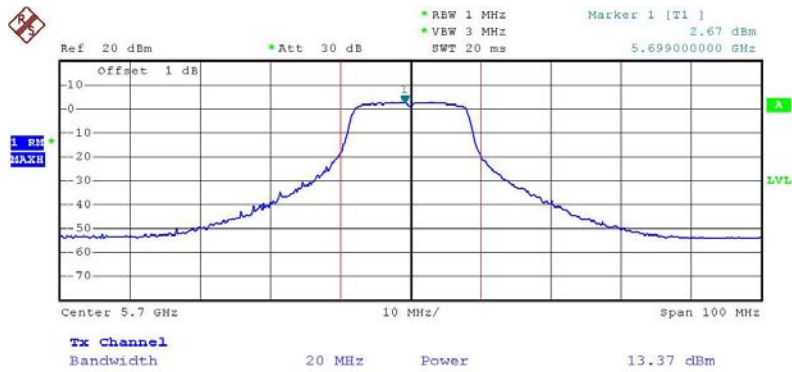

Date: 17.MAR.2008 17:04:47

Conducted Output Power Plot on Configuration IEEE 802.11 a Ant. 7-2 / 5700 MHz

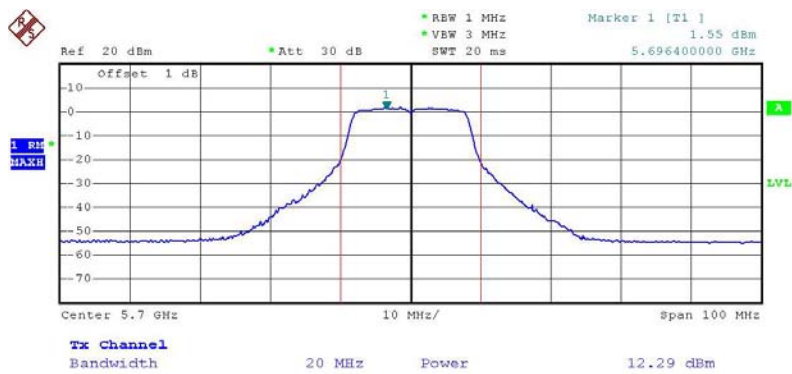

Date: 17.MAR.2008 17:05:52

Conducted Output Power Plot on Configuration IEEE 802.11 a Ant. 7-3 / 5700 MHz

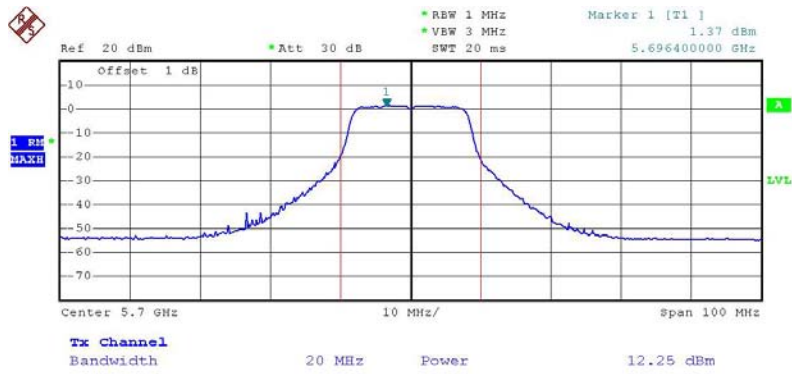

Date: 17.MAR.2008 17:06:40

4.4. Power Spectral Density Measurement

4.4.1. Limit

The power spectral density is defined as the highest level of power in dBm per MHz generated by the transmitter within the power envelope. The following table is power spectral density limits and decrease power density limit rule refer to section 4.3.1.

Frequency Range	Power Spectral Density limit (dBm/MHz)
5.15~5.25 GHz	4
5.25-5.35 GHz	11
5470-5725	11

4.4.2. Measuring Instruments and Setting

Please refer to section 5 of equipments list in this report. The following table is the setting of the spectrum analyzer.

Spectrum Parameter	Setting
Attenuation	Auto
Span Frequency	Encompass the entire emissions bandwidth (EBW) of the signal
RB	1000 kHz
VB	3000 kHz
Detector	Peak
Trace	Max Hold
Sweep Time	Auto

4.4.3. Test Procedures

1. The transmitter output (antenna port) was connected to the spectrum analyzer.
2. Set RBW of spectrum analyzer to 1000kHz and VBW to 3000kHz. Set Detector to Peak, Trace to Max Hold. Mark the frequency with maximum peak power as the center of the display of the spectrum.
3. Measuring multiple antennas, the connector is required to link with spectrum analyzer through a combiner.

4.4.4. Test Setup Layout

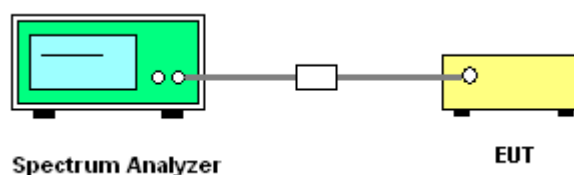

4.4.5. Test Deviation

There is no deviation with the original standard.

4.4.6. EUT Operation during Test

The EUT was programmed to be in continuously transmitting mode.

4.4.7. Test Result of Power Spectral Density

Temperature	22°C	Humidity	61%
Test Engineer	Sam Chen	Configurations	802.11a / Antenna 1

Configuration IEEE 802.11a Ant. 1

Channel	Frequency	Power Density (dBm)	Max. Limit (dBm)	Result
36	5180 MHz	1.69	4.00	Complies
40	5260 MHz	1.24	4.00	Complies
48	5240 MHz	1.85	4.00	Complies
52	5260 MHz	8.85	11.00	Complies
60	5300 MHz	9.14	11.00	Complies
64	5320 MHz	5.69	11.00	Complies
100	5500 MHz	3.96	11.00	Complies
116	5580 MHz	8.36	11.00	Complies
140	5700 MHz	4.26	11.00	Complies

Temperature	22°C	Humidity	61%
Test Engineer	Sam Chen	Configurations	802.11a / Antenna 5

Configuration IEEE 802.11a Ant. 5

Channel	Frequency	Power Density (dBm)	Max. Limit (dBm)	Result
36	5180 MHz	1.69	4.00	Complies
40	5260 MHz	1.24	4.00	Complies
48	5240 MHz	1.85	4.00	Complies
52	5260 MHz	8.85	11.00	Complies
60	5300 MHz	7.79	11.00	Complies
64	5320 MHz	4.56	11.00	Complies
100	5500 MHz	6.98	11.00	Complies
116	5580 MHz	8.36	11.00	Complies
140	5700 MHz	4.45	11.00	Complies

Temperature	22°C	Humidity	61%
Test Engineer	Sam Chen	Configurations	802.11a / Antenna 6

Configuration IEEE 802.11a Ant. 6

Channel	Frequency	Power Density (dBm)	Max. Limit (dBm)	Result
36	5180 MHz	-4.92	-3.00	Complies
40	5260 MHz	-5.03	-3.00	Complies
48	5240 MHz	-5.01	-3.00	Complies
52	5260 MHz	2.07	4.00	Complies
60	5300 MHz	1.59	4.00	Complies
64	5320 MHz	2.11	4.00	Complies
100	5500 MHz	1.81	4.00	Complies
116	5580 MHz	1.46	4.00	Complies
140	5700 MHz	2.26	4.00	Complies

Temperature	22°C	Humidity	61%
Test Engineer	Sam Chen	Configurations	802.11a / Antenna 7

Configuration IEEE 802.11a Ant. 7

Channel	Frequency	Power Density (dBm)	Max. Limit (dBm)	Result
36	5180 MHz	1.69	4.00	Complies
40	5260 MHz	1.24	4.00	Complies
48	5240 MHz	1.85	4.00	Complies
52	5260 MHz	8.85	11.00	Complies
60	5300 MHz	9.14	11.00	Complies
64	5320 MHz	4.56	11.00	Complies
100	5500 MHz	5.00	11.00	Complies
116	5580 MHz	8.36	11.00	Complies
140	5700 MHz	4.26	11.00	Complies

Power Density Plot on Configuration IEEE 802.11a Ant. 1 / 5180 MHz

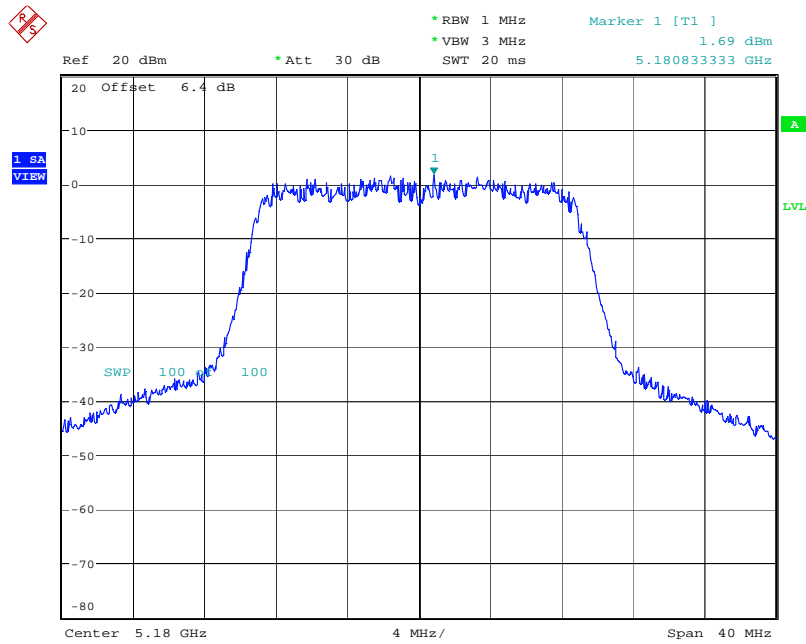

Date: 20.MAR.2008 20:02:43

Power Density Plot on Configuration IEEE 802.11a Ant. 1 / 5260 MHz

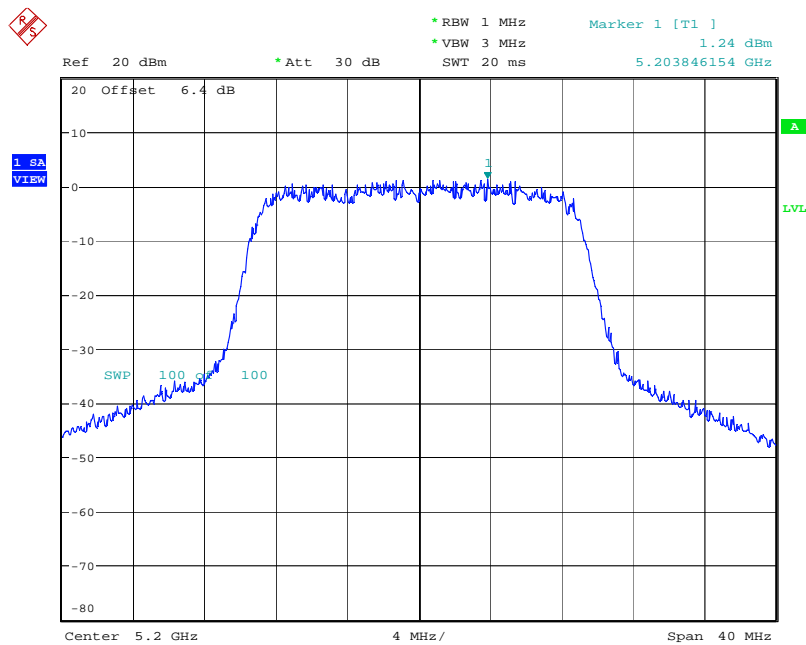

Date: 20.MAR.2008 20:01:09

Power Density Plot on Configuration IEEE 802.11a Ant. 1 / 5240 MHz

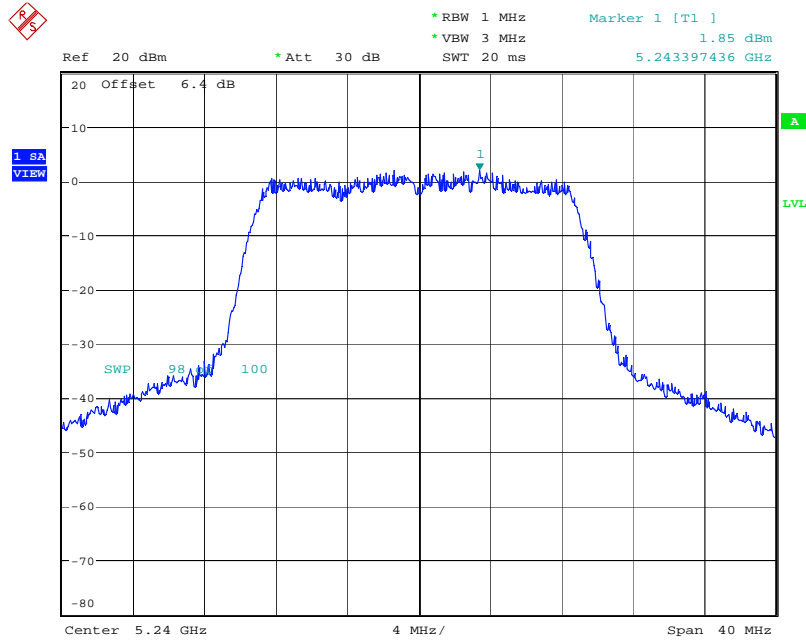

Date: 20.MAR.2008 19:58:55

Power Density Plot on Configuration IEEE 802.11a Ant. 1 / 5260 MHz

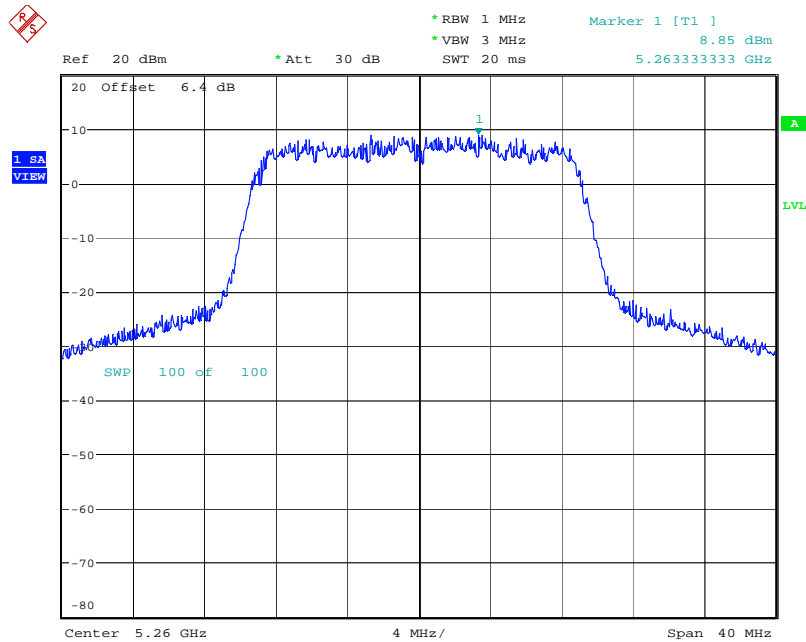

Date: 20.MAR.2008 19:57:22