



FCC RF Test Report

APPLICANT : Zebra Technologies Corporation
EQUIPMENT : WLAN/BT module
BRAND NAME : Zebra
MODEL NAME : 21-148603-0B
FCC ID : UZ7211486030B
STANDARD : FCC Part 15 Subpart E §15.407
CLASSIFICATION : (NII) Unlicensed National Information Infrastructure

The product was received on Nov. 13, 2015 and testing was completed on Nov. 26, 2015. We, SPORTON INTERNATIONAL INC., would like to declare that the tested sample has been evaluated in accordance with the test procedures and has been in compliance with the applicable technical standards.

The test results in this report apply exclusively to the tested model / sample. Without written approval of SPORTON INTERNATIONAL INC., the test report shall not be reproduced except in full.

Reviewed by: Joseph Lin / Supervisor

Approved by: Jones Tsai / Manager



SPORTON INTERNATIONAL INC.

No. 52, Hwa Ya 1st Rd., Hwa Ya Technology Park, Kwei-Shan District, Tao Yuan City, Taiwan, R.O.C.

SPORTON INTERNATIONAL INC.

TEL : 886-3-327-3456

FAX : 886-3-328-4978

FCC ID : UZ7211486030B

Page Number : 1 of 28

Report Issued Date : Mar. 16, 2016

Report Version : Rev. 01

Report Template No.: BU5-FR15EWL AC Version 1.2



TABLE OF CONTENTS

REVISION HISTORY 3

SUMMARY OF TEST RESULT 4

1 GENERAL DESCRIPTION 5

 1.1 Applicant 5

 1.2 Manufacturer 5

 1.3 Product Feature of Equipment Under Test 5

 1.4 Product Specification of Equipment Under Test 6

 1.5 Modification of EUT 7

 1.6 Testing Location 7

 1.7 Applicable Standards 7

2 TEST CONFIGURATION OF EQUIPMENT UNDER TEST 8

 2.1 Carrier Frequency and Channel 8

 2.2 Pre-Scanned RF Power 9

 2.3 Test Mode 10

 2.4 Connection Diagram of Test System 10

 2.5 EUT Operation Test Setup 11

 2.6 Measurement Results Explanation Example 11

3 TEST RESULT 12

 3.1 26dB & 99% Occupied Bandwidth Measurement 12

 3.2 Maximum Conducted Output Power Measurement 15

 3.3 Power Spectral Density Measurement 16

 3.4 Unwanted Emissions Measurement 19

 3.5 Frequency Stability Measurement 24

 3.6 Automatically Discontinue Transmission 25

 3.7 Antenna Requirements 26

4 LIST OF MEASURING EQUIPMENT 27

5 UNCERTAINTY OF EVALUATION 28

APPENDIX A. CONDUCTED TEST RESULTS

APPENDIX B. RADIATED TEST RESULTS

APPENDIX C. RADIATED TEST RESULTS OF PLOT

APPENDIX D. SETUP PHOTOGRAPHS



REVISION HISTORY

REPORT NO.	VERSION	DESCRIPTION	ISSUED DATE
FR3N0602-02A	Rev. 01	Updating the FCC 15E standard to new rule. In this report, tests are performed only for U-NII band I.	Mar. 16, 2016



SUMMARY OF TEST RESULT

Report Section	FCC Rule	Description	Limit	Result	Remark
3.1	2.1049 15.403(i)	26dB & 99% Bandwidth	-	Pass	-
3.2	15.407(a)	Maximum Conducted Output Power	≤ 24 dBm (depend on band)	Pass	-
3.3	15.407(a)	Power Spectral Density	≤ 11 dBm (depend on band)	Pass	-
3.4	15.407(b)	Unwanted Emissions	≤ -17, -27 dBm (depend on band)&15.209(a)	Pass	Under limit 1.44 dB at 5150.000 MHz
3.5	15.407(g)	Frequency Stability	Within Operation Band	Pass	-
3.6	15.407(c)	Automatically Discontinue Transmission	Discontinue Transmission	Pass	-
3.7	15.203 & 15.407(a)	Antenna Requirement	N/A	Pass	-



1 General Description

1.1 Applicant

Zebra Technologies Corporation
1 Zebra Plaza, Holtsville, NY 11742

1.2 Manufacturer

Zebra Technologies Corporation
1 Zebra Plaza, Holtsville, NY 11742

1.3 Product Feature of Equipment Under Test

Product Feature	
Equipment	WLAN/BT module
Brand Name	Zebra
Model Name	21-148603-0B
FCC ID	UZ7211486030B
EUT supports Radios application	WLAN 11a/n HT20 Bluetooth v2.1 EDR
Host HW Version	MV
Host SW Version	2.4.42930.0
Host FW Version	X_2.01.0.0.024R
MFD	11JUL15
EUT Stage	Identical Prototype

Remark: The above EUT's information was declared by manufacturer. Please refer to the specifications or user's manual for more detailed description.



1.4 Product Specification of Equipment Under Test

Standards-related Product Specification			
Tx/Rx Channel Frequency Range	5180 MHz ~ 5240 MHz		
Maximum Output Power	<Ant. 1> 802.11a : 17.36 dBm / 0.0545 W 802.11n HT20 : 16.23 dBm / 0.0420 W <Ant. 2> 802.11a : 17.06 dBm / 0.0508 W 802.11n HT20 : 16.07 dBm / 0.0405 W		
99% Occupied Bandwidth	802.11a : 21.65 MHz 802.11n HT20 : 20.00 MHz		
Type of Modulation	802.11a/n : OFDM (BPSK / QPSK / 16QAM / 64QAM)		
Antenna Type	PIFA Antenna		
Antenna Gain	<Ant. 1> : 4.19 dBi <Ant. 2> : 4.19 dBi		
Antenna Function Description		Ant. 1	Ant. 2
	802.11 a	V	V
	802.11 n	V	V



1.5 Modification of EUT

No modifications are made to the EUT during all test items.

1.6 Testing Location

Sporton Lab is accredited to ISO 17025 by Taiwan Accreditation Foundation (TAF code : 1190) and the FCC designation No. TW1022 under the FCC 2.948(e) by Mutual Recognition Agreement (MRA) in FCC Test.

Test Site	SPORTON INTERNATIONAL INC.
Test Site Location	No. 52, Hwa Ya 1 st Rd., Hwa Ya Technology Park, Kwei-Shan District, Tao Yuan City, Taiwan, R.O.C. TEL: +886-3-327-3456 FAX: +886-3-328-4978
Test Site No.	Sporton Site No.
	TH02-HY

Note: The test site complies with ANSI C63.4 2014 requirement.

Test Site	SPORTON INTERNATIONAL INC.
Test Site Location	No.58, Aly. 75, Ln. 564, Wenhua 3rd Rd. Guishan Dist, Taoyuan City, Taiwan (R.O.C.) TEL: +886-3-327-0868 FAX: +886-3-327-0855
Test Site No.	Sporton Site No.
	03CH10-HY

Note: The test site complies with ANSI C63.4 2014 requirement.

1.7 Applicable Standards

According to the specifications of the manufacturer, the EUT must comply with the requirements of the following standards:

- ♦ FCC Part 15 Subpart E
- ♦ FCC KDB 789033 D02 General UNII Test Procedures New Rules v01r01
- ♦ ANSI C63.10-2013

Remark: All test items were verified and recorded according to the standards and without any deviation during the test.



2 Test Configuration of Equipment Under Test

The EUT has been associated with peripherals and configuration operated in a manner tended to maximize its emission characteristics in a typical application. Frequency range investigated: radiated emission (9 kHz to the 10th harmonic of the highest fundamental frequency or to 40 GHz, whichever is lower). For radiated measurement, pre-scanned in three orthogonal panels, X, Y, Z. The worst cases (X plane for< Ant. 1>; Z plane for< Ant. 2>) were recorded in this report.

The final configuration from all the combinations and the worst-case data rates were investigated by measuring the maximum power across all the data rates and modulation modes under section 2.2.

Based on the worst configuration found above, the RF power setting is set individually to meet FCC compliance limit for the final conducted and radiated tests shown in section 2.3.

2.1 Carrier Frequency and Channel

Frequency Band	Channel	Freq. (MHz)	Channel	Freq. (MHz)
5150-5250 MHz Band 1 (U-NII-1)	36	5180	44	5220
	40	5200	48	5240



2.2 Pre-Scanned RF Power

Preliminary tests were performed in different data rate and data rate associated with the highest power were chosen for full test in the following tables. Final Output Power equals to Measured Output Power adds the duty factor.

<Ant. 1>

5GHz 802.11a mode Average Power(dBm)									
Data Rate (MHz)		6M bps	9M bps	12M bps	18M bps	24M bps	36M bps	48M bps	54M bps
CH36	5180 MHz	14.22	14.17	14.14	14.14	14.10	14.06	14.09	13.99
CH44	5220 MHz	17.36	17.30	17.26	17.27	17.29	17.28	17.31	17.32
CH48	5240 MHz	17.13	17.10	17.07	17.03	17.02	17.09	17.13	17.05

5GHz 802.11n HT20 mode Average Power(dBm)									
Data Rate (MHz)		MCS0	MCS1	MCS2	MCS3	MCS4	MCS5	MCS6	MCS7
CH36	5180 MHz	13.52	13.43	13.46	13.48	13.49	13.51	13.46	13.45
CH44	5220 MHz	16.12	16.04	15.99	15.99	15.92	15.93	15.94	15.93
CH48	5240 MHz	16.23	16.10	16.11	16.08	16.05	16.18	16.12	16.03

<Ant. 2>

5GHz 802.11a mode Average Power(dBm)									
Data Rate (MHz)		6M bps	9M bps	12M bps	18M bps	24M bps	36M bps	48M bps	54M bps
CH36	5180 MHz	13.72	13.52	13.41	13.48	13.40	13.43	13.51	13.60
CH44	5220 MHz	16.80	16.73	16.69	16.76	16.74	16.71	16.67	16.66
CH48	5240 MHz	17.06	16.99	16.97	16.97	16.95	16.93	16.95	16.90

5GHz 802.11n HT20 mode Average Power(dBm)									
Data Rate (MHz)		MCS0	MCS1	MCS2	MCS3	MCS4	MCS5	MCS6	MCS7
CH36	5180 MHz	13.22	13.11	13.11	13.09	13.05	13.00	12.96	12.93
CH44	5220 MHz	16.07	15.88	15.81	15.78	15.69	15.73	15.72	15.65
CH48	5240 MHz	15.57	15.52	15.42	15.36	15.27	15.36	15.14	15.06

2.3 Test Mode

Final test mode of conducted test items and radiated spurious emissions are considering the modulation and worse data rates from the power table described in section 2.2.

Single Antenna

Modulation	Data Rate
802.11a	6 Mbps
802.11n HT20	MCS0

Ch. #		Band I : 5150-5250 MHz	
		802.11a	802.11n HT20
L	Low	36	36
M	Middle	44	44
H	High	48	48

2.4 Connection Diagram of Test System

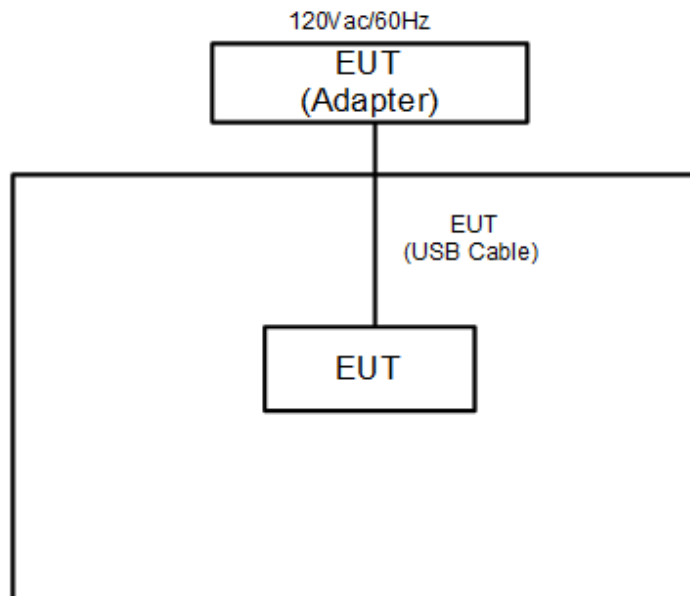



2.5 EUT Operation Test Setup

The programmed RF utility “XW2DMT”, is installed in EUT to provide channel selection, power level, data rate and the application type. RF Utility can send transmitting signal for all testing. The RF output power selection is for the setting of RF output power expected by the customer and is going to be fixed on the firmware of the final end product.

2.6 Measurement Results Explanation Example

For all conducted test items:

The offset level is set in the spectrum analyzer to compensate the RF cable loss and attenuator factor between EUT conducted output port and spectrum analyzer. With the offset compensation, the spectrum analyzer reading level is exactly the EUT RF output level.

Example :

The spectrum analyzer offset is derived from RF cable loss and attenuator factor.

Offset = RF cable loss + attenuator factor.

Following shows an offset computation example with cable loss 4.2 dB and 10dB attenuator.

$$\begin{aligned} \text{Offset(dB)} &= \text{RF cable loss(dB)} + \text{attenuator factor(dB)}. \\ &= 4.2 + 10 = 14.2 \text{ (dB)} \end{aligned}$$

3 Test Result

3.1 26dB & 99% Occupied Bandwidth Measurement

3.1.1 Description of 26dB & 99% Occupied Bandwidth

This section is for reporting purpose only.

There is no restriction limits for bandwidth.

3.1.2 Measuring Instruments

The measuring equipment is listed in the section 4 of this test report.

3.1.3 Test Procedures

1. The testing follows FCC KDB 789033 D02 General UNII Test Procedures New Rules v01r01.
Section C) Emission bandwidth
2. Set RBW = approximately 1% of the emission bandwidth.
3. Set the VBW > RBW.
4. Detector = Peak.
5. Trace mode = max hold
6. Measure the maximum width of the emission that is 26 dB down from the peak of the emission.
Compare this with the RBW setting of the analyzer. Readjust RBW and repeat measurement as needed until the RBW/EBW ratio is approximately 1%.
7. For 99% Bandwidth Measurement, the spectrum analyzer's resolution bandwidth (RBW) is set 1MHz and set the Video bandwidth (VBW) $\geq 3 * RBW$.
8. Measure and record the results in the test report.

3.1.4 Test Setup

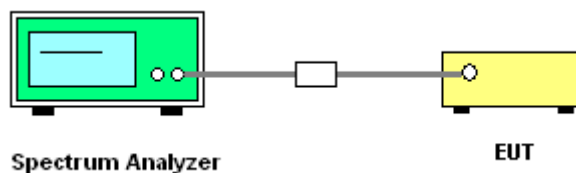



3.1.5 Test Result of 26dB & 99% Occupied Bandwidth

Please refer to Appendix A.

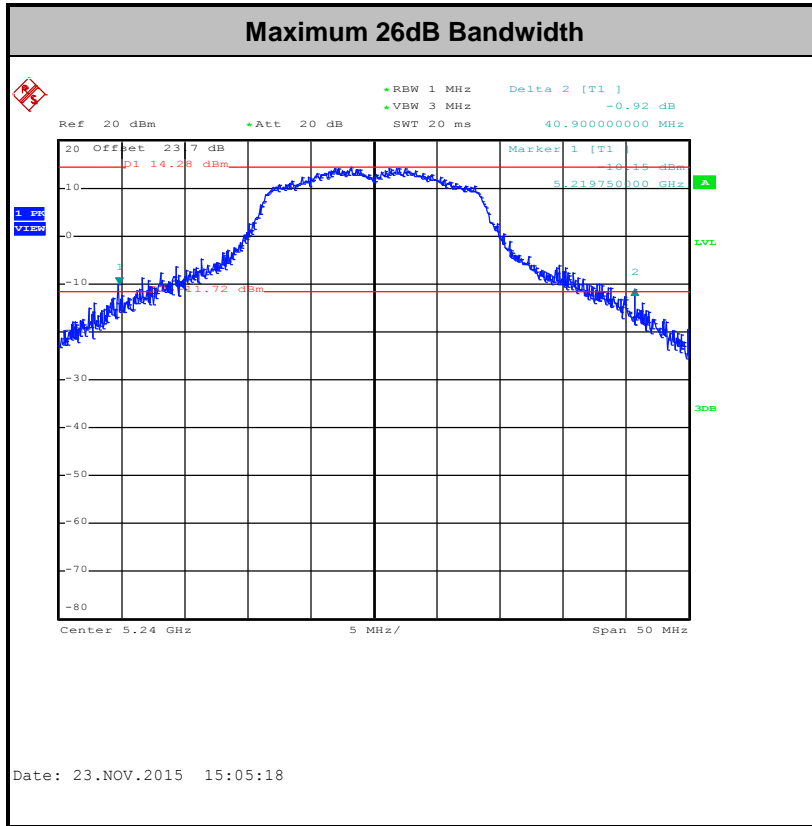

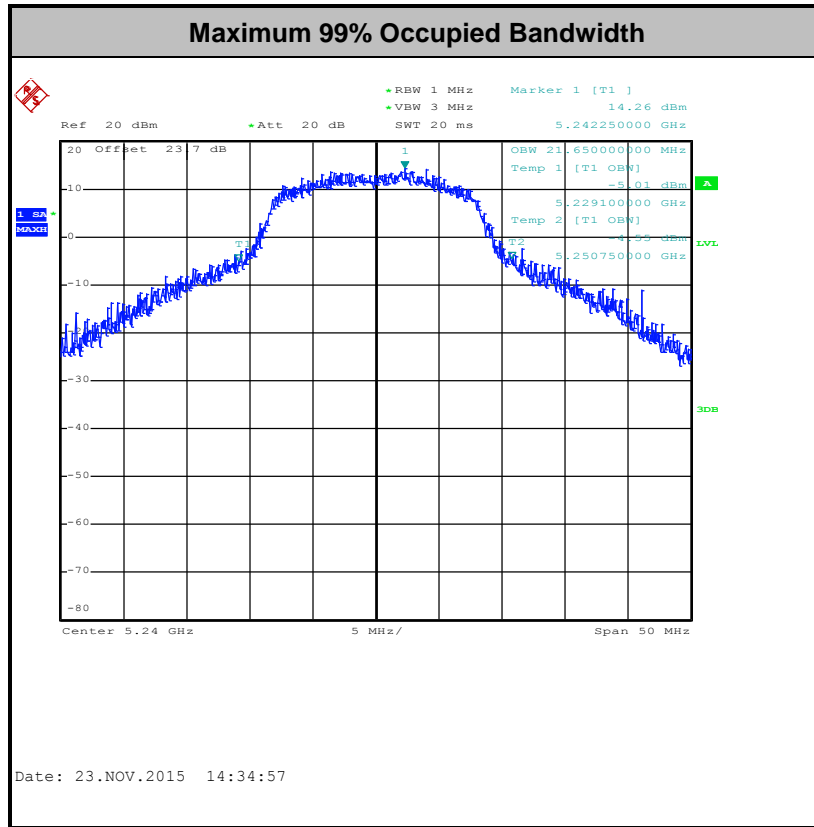

Note: The occupied channel bandwidth is maintained within the band of operation for all of the modulations.

3.2 Maximum Conducted Output Power Measurement

3.2.1 Limit of Maximum Conducted Output Power

For mobile and portable client devices in the 5.15–5.25 GHz band, the maximum conducted output power over the frequency band of operation shall not exceed 250 mW.

If transmitting antennas of directional gain greater than 6 dBi are used, the peak output power shall be reduced by the amount in dB that the directional gain of the antenna exceeds 6 dBi.

Note that U-NII-2 band, devices with a maximum e.i.r.p. greater than 500 mW shall implement TPC in order to have the capability to operate at least 6 dB below the maximum permitted e.i.r.p. of 1 W.

3.2.2 Measuring Instruments

The measuring equipment is listed in the section 4 of this test report.

3.2.3 Test Procedures

The testing follows Method PM of FCC KDB 789033 D02 General UNII Test Procedures New Rules v01r01.

Method PM (Measurement using an RF average power meter):

1. Measurement is performed using a wideband RF power meter.
2. The EUT is configured to transmit continuously with a consistent duty cycle at its maximum power control level.
3. Measure the average power of the transmitter, and the average power is corrected with duty factor, $10 \log(1/x)$, where x is the duty cycle.

3.2.4 Test Setup

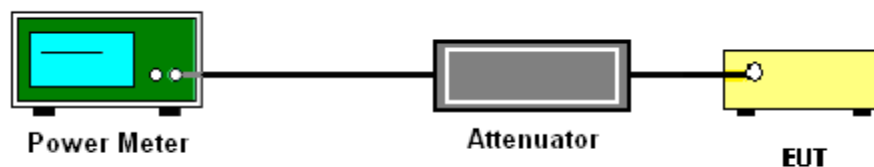

3.2.5 Test Result of Maximum Conducted Output Power

Please refer to Appendix A.



3.3 Power Spectral Density Measurement

3.3.1 Limit of Power Spectral Density

For mobile and portable client devices in the 5.15–5.25 GHz band, the maximum power spectral density shall not exceed 11dBm in any 1 megahertz band.

If transmitting antennas of directional gain greater than 6 dBi are used, the peak output power shall be reduced by the amount in dB that the directional gain of the antenna exceeds 6 dBi.

3.3.2 Measuring Instruments

The measuring equipment is listed in the section 4 of this test report.

3.3.3 Test Procedures

The testing follows FCC KDB 789033 D02 General UNII Test Procedures New Rules v01r01. Section F) Maximum power spectral density.

Method SA-2

(trace averaging across on and off times of the EUT transmissions, followed by duty cycle correction).

1. The testing follows Method SA-2 of FCC KDB 789033 D02 General UNII Test Procedures New Rules v01r01.
 - Measure the duty cycle.
 - Set span to encompass the entire emission bandwidth (EBW) of the signal.
 - Set RBW = 1 MHz.
 - Set VBW \geq 3 MHz.
 - Number of points in sweep \geq 2 Span / RBW.
 - Sweep time = auto.
 - Detector = RMS
 - Trace average at least 100 traces in power averaging mode.
 - Add $10 \log(1/x)$, where x is the duty cycle, to the measured power in order to compute the average power during the actual transmission times. For example, add $10 \log(1/0.25) = 6$ dB if the duty cycle is 25 percent.

2. The RF output of EUT was connected to the spectrum analyzer by a low loss cable.
3. Each plot has already offset with cable loss, and attenuator loss. Measure the PPSD and record it.
4. For MIMO mode, calculation method follows FCC KDB 662911 D01 Multiple Transmitter Output v02r01.

Method (1): Measure and sum the spectra across the outputs.

The total final Power Spectral Density is from a device with 2 transmitter outputs. The spectrum measurements of the individual outputs are all performed with the same span and number of points, the spectrum value in the first spectral bin of output 1 is summed with that in the first spectral bin of output 2 to obtain the value for the first frequency bin of the summed spectrum.

3.3.4 Test Setup

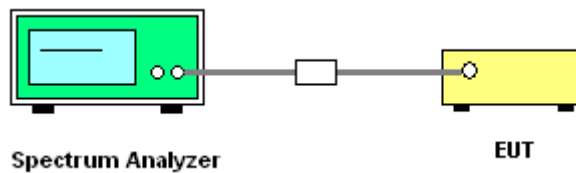



3.3.5 Test Result of Power Spectral Density

Please refer to Appendix A.

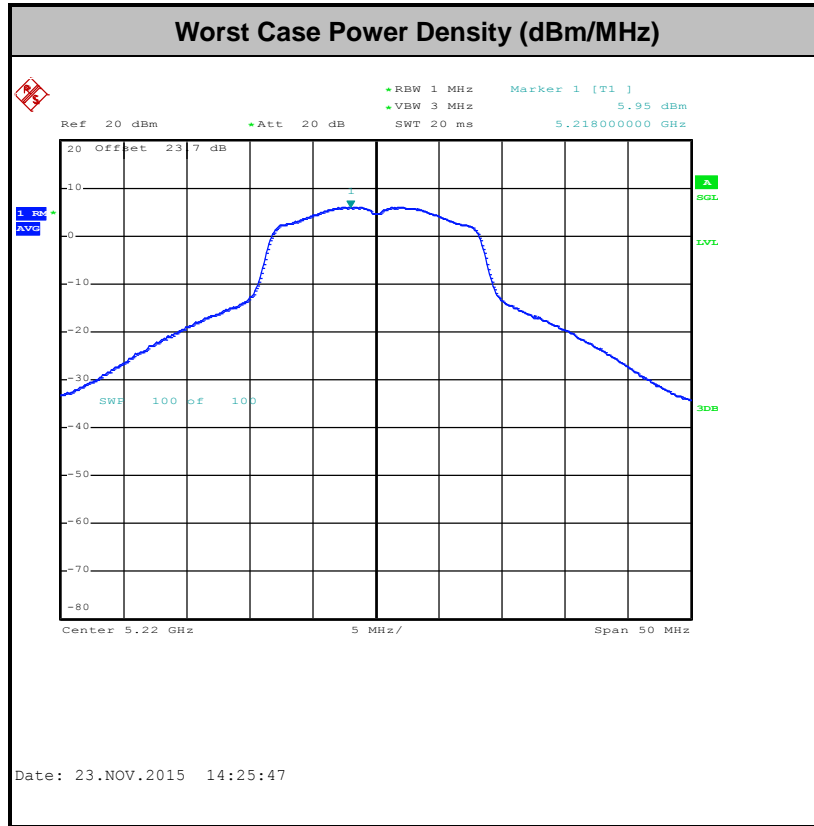

Note: Average Power Density (dB) = Measured value+ Duty Factor



3.4 Unwanted Emissions Measurement

This section as specified in FCC Part 15.407(b) is to measure unwanted emissions through radiated measurement for band edge spurious emissions and out of band emissions measurement. The unwanted emissions shall comply with 15.407(b)(1) to (6), and restricted bands per FCC Part15.205.

3.4.1 Limit of Unwanted Emissions

- (1) For transmitters operating in the 5150-5250 MHz band: all emissions outside of the 5150-5350 MHz band shall not exceed an EIRP of -27dBm/MHz.
- (2) Unwanted spurious emissions fallen in restricted bands per FCC Part15.205 shall comply with the general field strength limits set forth in § 15.209 as below table,

Frequency (MHz)	Field Strength (microvolts/meter)	Measurement Distance (meters)
0.009 – 0.490	2400/F(kHz)	300
0.490 – 1.705	24000/F(kHz)	30
1.705 – 30.0	30	30
30 – 88	100	3
88 – 216	150	3
216 - 960	200	3
Above 960	500	3

Note: The following formula is used to convert the EIRP to field strength.

$$E = \frac{1000000\sqrt{30P}}{3} \mu V/m, \text{ where } P \text{ is the eirp (Watts)}$$

EIRP (dBm)	Field Strength at 3m (dBµV/m)
-17	78.3
- 27	68.3

- (3) KDB789033 D02 v01r01 G)2)c) As specified in 15.407(b), emissions above 1000 MHz that are outside of the restricted bands are subject to a peak emission limit of -27 dBm/MHz (or -17 dBm/MHz as specified in 15.407(b)(4)). However, an out-of-band emission that complies with both the average and peak limits of 15.209 is not required to satisfy the -27 dBm/MHz or -17 dBm/MHz peak emission limit.

3.4.2 Measuring Instruments

The measuring equipment is listed in the section 4 of this test report.



3.4.3 Test Procedures

1. The testing follows FCC KDB 789033 D02 General UNII Test Procedures New Rules v01r01.
Section G) Unwanted emissions measurement.

(1) Procedure for Unwanted Emissions Measurements Below 1000MHz

- RBW = 120 kHz
- VBW = 300 kHz
- Detector = Peak
- Trace mode = max hold

(2) Procedure for Peak Unwanted Emissions Measurements Above 1000 MHz

- RBW = 1 MHz
- VBW \geq 3 MHz
- Detector = Peak
- Sweep time = auto
- Trace mode = max hold



(3) Procedures for Average Unwanted Emissions Measurements Above 1000MHz

- RBW = 1 MHz
- VBW = 10 Hz, when duty cycle is no less than 98 percent.
- $VBW \geq 1/T$, when duty cycle is less than 98 percent where T is the minimum transmission duration over which the transmitter is on and is transmitting at its maximum power control level for the tested mode of operation.

Antenna	Band	Duty Cycle(%)	T(us)	1/T(kHz)	VBW Setting
1	802.11a	98.57	-	-	10Hz
1	802.11n HT20	97.18	2760	0.36	1kHz
2	802.11a	98.57	-	-	10Hz
2	802.11n HT20	97.18	2760	0.36	1kHz

- The EUT was placed on a turntable with 0.8 meter for frequency below 1GHz and 1.5 meter for frequency above 1GHz respectively above ground.
- The EUT was set 3 meters from the interference receiving antenna which was mounted on the top of a variable height antenna tower.
- The antenna is a broadband antenna and its height is adjusted between one meter and four meters above ground to find the maximum value of the field strength for both horizontal polarization and vertical polarization of the antenna.
- For each suspected emission, the EUT was arranged to its worst case and then adjust the antenna tower (from 1 m to 4 m) and turntable (from 0 degree to 360 degrees) to find the maximum reading.
- For testing below 1GHz, if the emission level of the EUT in peak mode was 3 dB lower than the limit specified, then peak values of EUT will be reported, otherwise, the emissions will be repeated one by one using the CISPR quasi-peak method and reported.
- For testing above 1GHz, the emission level of the EUT in peak mode was 20dB lower than average limit (that means the emission level in average mode also complies with the limit in average mode), then peak values of EUT will be reported, otherwise, the emissions will be measured in average mode again and reported.

3.4.4 Test Setup

For radiated emissions below 30MHz

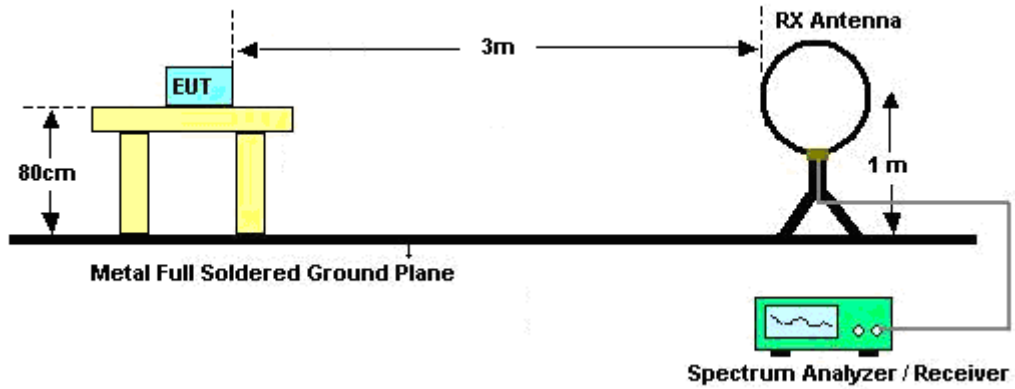

For radiated emissions from 30MHz to 1GHz

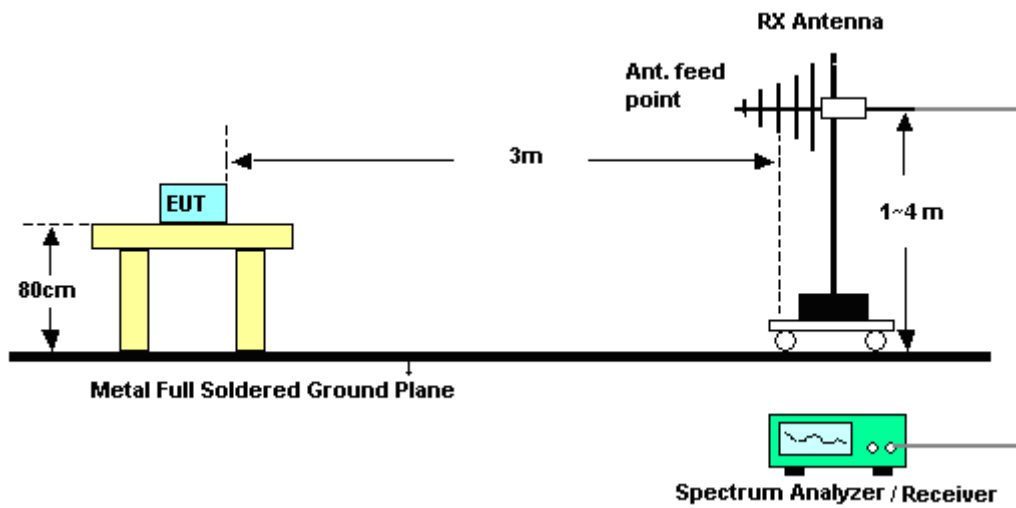

For radiated emissions above 1GHz

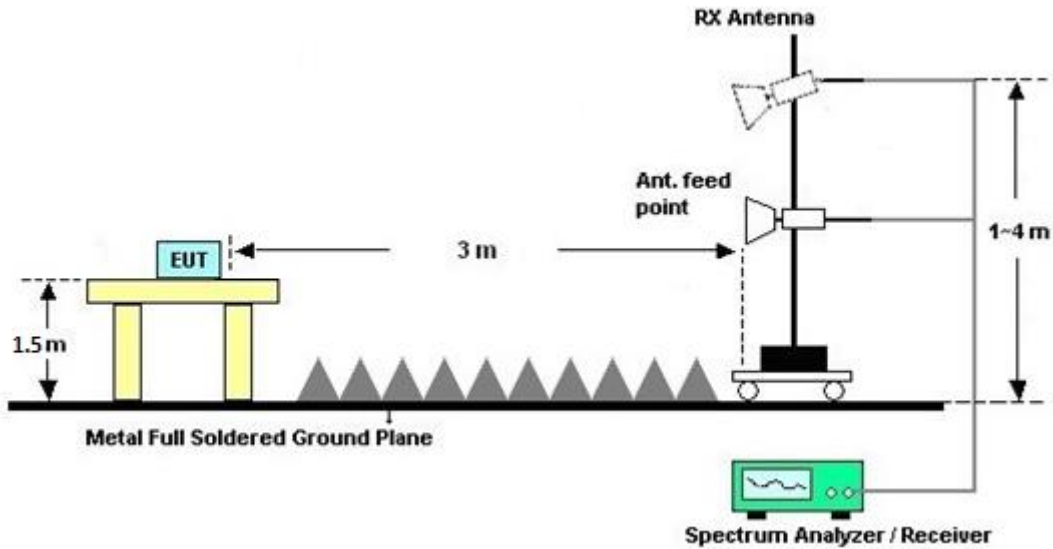

3.4.5 Test Results of Radiated Emissions (9 kHz ~ 30 MHz)

The low frequency, which started from 9 kHz to 30MHz, was pre-scanned and the result which was 20dB lower than the limit line per 15.31(o) was not reported.

3.4.6 Test Result of Radiated Band Edges

Please refer to Appendix B and C.

3.4.7 Test Result of Unwanted Radiated Emission (30MHz ~ 10th Harmonic)

Please refer to Appendix B and C.

3.5 Frequency Stability Measurement

3.5.1 Limit of Frequency Stability

Manufacturers of U-NII devices are responsible for ensuring frequency stability such that an emission is maintained within the band of operation under all conditions of normal operation as specified in the user's manual.

3.5.2 Measuring Instruments

The measuring equipment is listed in the section 4 of this test report.

3.5.3 Test Procedures

1. To ensure emission at the band edge is maintained within the authorized band, those values shall be measured by radiation emissions at upper and lower frequency points, and finally compensated by frequency deviation as procedures below.
2. The EUT was operated at the maximum output power, and connected to the spectrum analyzer, which is set to maximum hold function and peak detector. The peak value of the power envelope was measured and noted. The upper and lower frequency points were respectively measured relatively 10dB lower than the measured peak value.
3. The frequency deviation was calculated by adding the upper frequency point and the lower frequency point divided by two. Those detailed values of frequency deviation are provided in table below.

3.5.4 Test Setup



3.5.5 Test Result of Frequency Stability

Please refer to Appendix A.



3.6 Automatically Discontinue Transmission

3.6.1 Limit of Automatically Discontinue Transmission

The device shall automatically discontinue transmission in case of either absence of information to transmit or operational failure. These provisions are not intended to preclude the transmission of control or signaling information or the use of repetitive codes used by certain digital technologies to complete frame or burst intervals. Applicants shall include in their application for equipment authorization to describe how this requirement is met.

3.6.2 Measuring Instruments

The measuring equipment is listed in the section 4 of this test report.

3.6.3 Test Result of Automatically Discontinue Transmission

While the EUT is not transmitting any information, the EUT can automatically discontinue transmission and become standby mode for power saving. The EUT can detect the controlling signal of ACK message transmitting from remote device and verify whether it shall resend or discontinue transmission.



3.7 Antenna Requirements

3.7.1 Standard Applicable

According to FCC 47 CFR Section 15.407(a)(1)(2) ,if transmitting antenna directional gain is greater than 6 dBi, both the peak transmit power and the peak power spectral density shall be reduced by the amount in dB that the directional gain of the antenna exceeds 6 dBi.

3.7.2 Antenna Anti-Replacement Construction

An embedded-in antenna design is used.

3.7.3 Antenna Gain

FCC KDB 662911 D01 Multiple Transmitter Output v02r01

For CDD transmissions, directional gain is calculated as

Directional gain = G_{ANT} + Array Gain, where Array Gain is as follows.

For power spectral density (PSD) measurements on all devices,

Array Gain = $10 \log(N_{ANT}/N_{SS}=1)$ dB.

For power measurements on IEEE 802.11 devices,

Array Gain = 0 dB (i.e., no array gain) for $N_{ANT} \leq 4$.

Directional gain may be calculated by using the formulas applicable to equal gain antennas with G_{ANT} set equal to the gain of the antenna having the highest gain;

The power and PSD limit should be modified if the directional gain of EUT is over 6 dBi,

The directional gain "DG" is calculated as following table.

			DG for Power (dBi)	DG for PSD (dBi)	Power Limit Reduction (dB)	PSD Limit Reduction (dB)
Band I	Ant 1 (dBi)	Ant 2 (dBi)	4.19	7.20	0.00	1.20
	4.19	4.19	4.19	7.20	0.00	1.20

Power limit reduction = Composite gain – 6dBi, (min = 0)

PSD limit reduction = Composite gain + PSD Array gain – 6dBi, (min = 0)



4 List of Measuring Equipment

Instrument	Manufacturer	Model No.	Serial No.	Characteristics	Calibration Date	Test Date	Due Date	Remark
DC Power Supply	TOPWARD	3303D	740889	N/A	May. 27, 2015	Nov. 24, 2015~ Nov. 25, 2015	May. 26, 2016	Conducted (TH02-HY)
Power Meter	Agilent	E4416A	GB41292344	300MHz~40GHz	Jan. 14, 2015	Nov. 24, 2015~ Nov. 25, 2015	Jan. 13, 2016	Conducted (TH02-HY)
Power Sensor	Agilent	E9327A	US40441548	300MHz~40GHz	Jan. 14, 2015	Nov. 24, 2015~ Nov. 25, 2015	Jan. 13, 2016	Conducted (TH02-HY)
Spectrum Analyzer	Rohde & Schwarz	FSP40	100055	9kHz~40GHz	Jun. 18, 2015	Nov. 24, 2015~ Nov. 25, 2015	Jun. 17, 2016	Conducted (TH02-HY)
Loop Antenna	Rohde & Schwarz	HFH2-Z2	100315	9 kHz~30 MHz	Sep. 02, 2015	Nov. 13, 2015~ Nov. 26, 2015	Sep. 01, 2016	Radiation (03CH10-HY)
Bilog Antenna	TESEQ	CBL 6111D	35413	30MHz~1GHz	Oct. 31, 2015	Nov. 13, 2015~ Nov. 26, 2015	Oct. 30, 2016	Radiation (03CH10-HY)
EMI Test Receiver	Keysight	N9038A(MXE)	MY54130085	20Hz ~ 8.4GHz	Nov. 04, 2015	Nov. 13, 2015~ Nov. 26, 2015	Nov. 03, 2016	Radiation (03CH10-HY)
Horn Antenna	SCHWARZBECK	BBHA 9120 D	9120D-1325	1GHz ~ 18GHz	Sep. 30, 2015	Nov. 13, 2015~ Nov. 26, 2015	Sep. 29, 2016	Radiation (03CH10-HY)
Preamplifier	Keysight	83017A	MY53270078	1GHz~26.5GHz	Nov. 13, 2015	Nov. 13, 2015~ Nov. 26, 2015	Nov. 12, 2016	Radiation (03CH10-HY)
Spectrum Analyzer	Keysight	N9010A	MY54200485	10Hz ~ 44GHZ	Oct. 15, 2015	Nov. 13, 2015~ Nov. 26, 2015	Oct. 14, 2016	Radiation (03CH10-HY)
Controller	EMEC	EM 1000	N/A	Control Turn table & Ant Mast	N/A	Nov. 13, 2015~ Nov. 26, 2015	N/A	Radiation (03CH10-HY)
Antenna Mast	EMEC	AM-BS-4500-B	N/A	1~4m	N/A	Nov. 13, 2015~ Nov. 26, 2015	N/A	Radiation (03CH10-HY)
Turn Table	EMEC	TT 2200	N/A	0-360 degree	N/A	Nov. 13, 2015~ Nov. 26, 2015	N/A	Radiation (03CH10-HY)
Preamplifier	MITEQ	AMF-7D-0010 1800-30-10P	1902247	1GHz~18GHz	Jul. 01, 2015	Nov. 13, 2015~ Nov. 26, 2015	Jun. 30, 2016	Radiation (03CH10-HY)
Amplifier	Sonoma-Instrument	310 N	187282	10MHz~1GHz	Jan. 14, 2015	Nov. 13, 2015~ Nov. 26, 2015	Jan. 13, 2016	Radiation (03CH10-HY)
Horn Antenna	SCHWARZBECK	BBHA 9170	BBHA917058 4	18GHz- 40GHz	Nov. 02, 2015	Nov. 13, 2015~ Nov. 26, 2015	Nov. 01, 2016	Radiation (03CH10-HY)
Preamplifier	MITEQ	JS44-1800400 0-33-8P	1840917	18GHz ~ 40GHz	Jun. 02, 2015	Nov. 13, 2015~ Nov. 26, 2015	Jun. 01, 2016	Radiation (03CH10-HY)



5 Uncertainty of Evaluation

Uncertainty of Conducted Emission Measurement (150kHz ~ 30MHz)

Measuring Uncertainty for a Level of Confidence of 95% ($U = 2Uc(y)$)	2.70
---	------

Uncertainty of Radiated Emission Measurement (30 MHz ~ 1000 MHz)

Measuring Uncertainty for a Level of Confidence of 95% ($U = 2Uc(y)$)	4.90
---	------



Appendix A. Conducted Test Results

Test Engineer:	AC CHANG	Temperature:	21~25	°C
Test Date:	Nov. 24, 2015 ~ Nov. 25, 2015	Relative Humidity:	51~54	%

TEST RESULTS DATA
26dB and 99% OBW

Band I													
Mod.	Data Rate	NTX	CH.	Freq. (MHz)	99% Bandwidth (MHz)		26 dB Bandwidth (MHz)		IC 99% Bandwidth Power Limit (dBm)		IC 99% Bandwidth EIRP Limit (dBm)		Note
					Ant 1	Ant 2	Ant 1	Ant 2	Ant 1	Ant 2	Ant 1	Ant 2	
11a	6Mbps	1	36	5180	17.95		32.10		-		22.54		
11a	6Mbps	1	44	5220	20.75		38.05		-		23.01		
11a	6Mbps	1	48	5240	21.65		39.15		-		23.01		
HT20	MCS0	1	36	5180	18.90		28.60		-		22.76		
HT20	MCS0	1	44	5220	19.35		37.95		-		22.87		
HT20	MCS0	1	48	5240	20.00		40.90		-		23.01		

TEST RESULTS DATA
Average Power Table

FCC Band I														
Mod.	Data Rate	NTX	CH.	Freq. (MHz)	Duty Factor (dB)		Average Conducted Power (dBm)			FCC Conducted Power Limit (dBm)		DG (dBi)		Pass/Fail
					Ant 1	Ant 2	Ant 1	Ant 2	SUM	Ant 1	Ant 2	Ant 1	Ant 2	
11a	6Mbps	1	36	5180	0.06	0.06	14.22	13.72		24.00	24.00	4.19	4.19	Pass
11a	6Mbps	1	44	5220	0.06	0.06	17.36	16.80		24.00	24.00	4.19	4.19	Pass
11a	6Mbps	1	48	5240	0.06	0.06	17.13	17.06		24.00	24.00	4.19	4.19	Pass
HT20	MCS0	1	36	5180	0.12	0.12	13.52	13.22		24.00	24.00	4.19	4.19	Pass
HT20	MCS0	1	44	5220	0.12	0.12	16.12	16.07		24.00	24.00	4.19	4.19	Pass
HT20	MCS0	1	48	5240	0.12	0.12	16.23	15.57		24.00	24.00	4.19	4.19	Pass

TEST RESULTS DATA
Power Spectral Density

FCC Band I														
Mod.	Data Rate	NTX	CH.	Freq. (MHz)	Duty Factor (dB)		Average Power Density (dBm/MHz)			Average PSD Limit (dBm/MHz)		DG (dBi)		Pass /Fail
					Ant 1	Ant 2	Ant 1	Ant 2	SUM	Ant 1	Ant 2	Ant 1	Ant 2	
11a	6Mbps	1	36	5180	0.06	0.06	3.38			11.00	11.00	4.19	4.19	Pass
11a	6Mbps	1	44	5220	0.06	0.06	6.01			11.00	11.00	4.19	4.19	Pass
11a	6Mbps	1	48	5240	0.06	0.06	5.93			11.00	11.00	4.19	4.19	Pass
HT20	MCS0	1	36	5180	0.12	0.12	2.97			11.00	11.00	4.19	4.19	Pass
HT20	MCS0	1	44	5220	0.12	0.12	5.04			11.00	11.00	4.19	4.19	Pass
HT20	MCS0	1	48	5240	0.12	0.12	5.04			11.00	11.00	4.19	4.19	Pass

TEST RESULTS DATA
Frequency Stability

Band I										
Mod.	Data Rate	NTX	CH.	Freq. (MHz)	Center Frequency (MHz)	Frequency Deviation (MHz)	Frequency Stability (ppm)	Temperature (°C)	Voltage (V)	Note
11a	6Mbps	1	36	5180	5180.000	0.000	0.00	20	3.4	
11a	6Mbps	1	36	5180	5180.000	0.000	0.00	20	4.2	
11a	6Mbps	1	36	5180	5180.025	0.025	4.83	20	3.7	
11a	6Mbps	1	36	5180	5179.975	-0.025	-4.83	-30	3.7	
11a	6Mbps	1	36	5180	5179.975	-0.025	-4.83	50	3.7	



Appendix B. Radiated Spurious Emission

Band 1 - 5150~5250MHz

WIFI 802.11a (Band Edge @ 3m)

WIFI Ant.	Note	Frequency	Level	Over Limit	Limit Line	Read Level	Antenna Factor	Cable Loss	Preamp Factor	Ant Pos	Table Pos	Peak Avg.	Pol.	
1		(MHz)	(dBμV/m)	(dB)	(dBμV/m)	(dBμV)	(dB/m)	(dB)	(dB)	(cm)	(deg)	(P/A)	(H/V)	
802.11a CH 36 5180MHz		5147.75	62.96	-11.04	74	55.27	31.98	7.94	32.23	100	130	P	H	
		5150	51.61	-2.39	54	43.92	31.98	7.94	32.23	100	130	A	H	
	*	5182	110.47	-	-	102.76	32.02	7.91	32.22	100	130	P	H	
	*	5182	103.47	-	-	95.76	32.02	7.91	32.22	100	130	A	H	
													H	
														H
			5150	61.47	-12.53	74	53.78	31.98	7.94	32.23	107	48	P	V
			5150	51.04	-2.96	54	43.35	31.98	7.94	32.23	107	48	A	V
	*		5182	109.63	-	-	101.92	32.02	7.91	32.22	107	48	P	V
	*		5182	102.53	-	-	94.82	32.02	7.91	32.22	107	48	A	V
														V
														V
802.11a CH 44 5220MHz		5141.3	53.39	-20.61	74	45.7	31.98	7.94	32.23	100	138	P	H	
		5149.85	45.78	-8.22	54	38.09	31.98	7.94	32.23	100	138	A	H	
	*	5222	115.2	-	-	107.34	32.06	8.01	32.21	100	138	P	H	
	*	5222	108.1	-	-	100.24	32.06	8.01	32.21	100	138	A	H	
			5357.04	55.26	-18.74	74	46.99	32.22	8.23	32.18	100	138	P	H
			5350	47.18	-6.82	54	38.91	32.22	8.23	32.18	100	138	A	H
			5143.25	57.82	-16.18	74	50.13	31.98	7.94	32.23	100	47	P	V
			5150	45.69	-8.31	54	38	31.98	7.94	32.23	100	47	A	V
	*		5222	113.78	-	-	105.92	32.06	8.01	32.21	100	47	P	V
	*		5222	106.8	-	-	98.94	32.06	8.01	32.21	100	47	A	V
			5356.93	53.7	-20.3	74	45.43	32.22	8.23	32.18	100	47	P	V
			5350	43.99	-10.01	54	35.72	32.22	8.23	32.18	100	47	A	V



802.11a CH 48 5240MHz		5131.4	51.33	-22.67	74	43.67	31.96	7.94	32.24	100	140	P	H
		5149.85	42.31	-11.69	54	34.62	31.98	7.94	32.23	100	140	A	H
	*	5242	114.41	-	-	106.4	32.1	8.12	32.21	100	140	P	H
	*	5242	107.33	-	-	99.32	32.1	8.12	32.21	100	140	A	H
		5353.96	53.59	-20.41	74	45.32	32.22	8.23	32.18	100	140	P	H
		5350.11	44.09	-9.91	54	35.82	32.22	8.23	32.18	100	140	A	H
		5146.55	52.22	-21.78	74	44.53	31.98	7.94	32.23	100	49	P	V
		5149.4	42.7	-11.3	54	35.01	31.98	7.94	32.23	100	49	A	V
	*	5238	113.23	-	-	105.35	32.08	8.01	32.21	100	49	P	V
	*	5238	106.2	-	-	98.32	32.08	8.01	32.21	100	49	A	V
		5366.06	50.55	-23.45	74	42.19	32.24	8.29	32.17	100	49	P	V
		5350	42.24	-11.76	54	33.97	32.22	8.23	32.18	100	49	A	V
Remark	1. No other spurious found. 2. All results are PASS against Peak and Average limit line.												



Band 1 5150~5250MHz

WIFI 802.11a (Harmonic @ 3m)

WIFI Ant. 1	Note	Frequency (MHz)	Level (dBμV/m)	Over Limit (dB)	Limit Line (dBμV/m)	Read Level (dBμV)	Antenna Factor (dB/m)	Cable Loss (dB)	Preamp Factor (dB)	Ant Pos (cm)	Table Pos (deg)	Peak Avg. (P/A)	Pol. (H/V)
802.11a CH 36 5180MHz		10359	46.28	-27.72	74	57.74	39.69	11.96	63.11	100	0	P	H
		15540	44.09	-29.91	74	51.48	38.04	14.76	60.19	100	0	P	H
													H
													H
		10359	46.09	-27.91	74	57.55	39.69	11.96	63.11	100	0	P	V
		15540	42.95	-31.05	74	50.34	38.04	14.76	60.19	100	0	P	V
													V
													V
802.11a CH 44 5220MHz		10440	45.27	-28.73	74	56.5	39.79	12.03	63.05	100	0	P	H
		15660	44.47	-29.53	74	52	37.85	14.79	60.17	100	0	P	H
													H
													H
		10440	46.35	-27.65	74	57.58	39.79	12.03	63.05	100	0	P	V
		15660	43.94	-30.06	74	51.47	37.85	14.79	60.17	100	0	P	V
													V
													V
802.11a CH 48 5240MHz		10480	45.67	-28.33	74	56.75	39.87	12.06	63.01	100	0	P	H
		15720	43.15	-30.85	74	50.76	37.74	14.81	60.16	100	0	P	H
													H
													H
		10480	45.29	-28.71	74	56.37	39.87	12.06	63.01	100	0	P	V
		15720	43.06	-30.94	74	50.67	37.74	14.81	60.16	100	0	P	V
													V
													V
Remark	1. No other spurious found. 2. All results are PASS against Peak and Average limit line.												



Band 1 5150~5250MHz

WIFI 802.11n HT20 (Band Edge @ 3m)

WIFI Ant. 1	Note	Frequency (MHz)	Level (dBμV/m)	Over Limit (dB)	Limit Line (dBμV/m)	Read Level (dBμV)	Antenna Factor (dB/m)	Cable Loss (dB)	Preamp Factor (dB)	Ant Pos (cm)	Table Pos (deg)	Peak Avg. (P/A)	Pol. (H/V)	
802.11n HT20 CH 36 5180MHz		5149.4	61.26	-12.74	74	53.57	31.98	7.94	32.23	100	138	P	H	
		5149.55	51.74	-2.26	54	44.05	31.98	7.94	32.23	100	138	A	H	
	*	5178	108.75	-	-	101.04	32.02	7.91	32.22	100	138	P	H	
	*	5178	101.75	-	-	94.04	32.02	7.91	32.22	100	138	A	H	
													H	
														H
			5149.4	63.67	-10.33	74	55.98	31.98	7.94	32.23	107	48	P	V
			5150	51.7	-2.3	54	44.01	31.98	7.94	32.23	107	48	A	V
		*	5182	110.01	-	-	102.3	32.02	7.91	32.22	107	48	P	V
		*	5182	103.01	-	-	95.3	32.02	7.91	32.22	107	48	A	V
													V	
													V	
802.11n HT20 CH 44 5220MHz		5130.65	51.99	-22.01	74	44.33	31.96	7.94	32.24	100	140	P	H	
		5149.4	43.67	-10.33	54	35.98	31.98	7.94	32.23	100	140	A	H	
	*	5219	113.61	-	-	105.75	32.06	8.01	32.21	100	140	P	H	
	*	5219	106.63	-	-	98.77	32.06	8.01	32.21	100	140	A	H	
			5362.87	52.46	-21.54	74	44.1	32.24	8.29	32.17	100	140	P	H
			5350	44.24	-9.76	54	35.97	32.22	8.23	32.18	100	140	A	H
			5142.05	51.92	-22.08	74	44.23	31.98	7.94	32.23	100	48	P	V
			5149.4	43.41	-10.59	54	35.72	31.98	7.94	32.23	100	48	A	V
		*	5221	111.18	-	-	103.32	32.06	8.01	32.21	100	48	P	V
		*	5221	104.18	-	-	96.32	32.06	8.01	32.21	100	48	A	V
		5369.14	51.76	-22.24	74	43.4	32.24	8.29	32.17	100	48	P	V	
		5362.87	42.78	-11.22	54	34.42	32.24	8.29	32.17	100	48	A	V	



802.11n HT20 CH 48 5240MHz		5122.25	51.14	-22.86	74	43.5	31.94	7.94	32.24	100	140	P	H
		5147.75	42.64	-11.36	54	34.95	31.98	7.94	32.23	100	140	A	H
	*	5242	113.71	-	-	105.7	32.1	8.12	32.21	100	140	P	H
	*	5242	106.72	-	-	98.71	32.1	8.12	32.21	100	140	A	H
		5366.39	52.92	-21.08	74	44.56	32.24	8.29	32.17	100	140	P	H
		5352.53	44.88	-9.12	54	36.61	32.22	8.23	32.18	100	140	A	H
		5132.75	51.12	-22.88	74	43.46	31.96	7.94	32.24	100	48	P	V
		5149.85	42.66	-11.34	54	34.97	31.98	7.94	32.23	100	48	A	V
	*	5242	111.43	-	-	103.42	32.1	8.12	32.21	100	48	P	V
	*	5242	104.33	-	-	96.32	32.1	8.12	32.21	100	48	A	V
		5420.73	50.77	-23.23	74	42.34	32.3	8.29	32.16	100	48	P	V
		5350.88	42.57	-11.43	54	34.3	32.22	8.23	32.18	100	48	A	V
Remark	1. No other spurious found. 2. All results are PASS against Peak and Average limit line.												



Band 1 5150~5250MHz

WIFI 802.11n HT20 (Harmonic @ 3m)

WIFI Ant. 1	Note	Frequency (MHz)	Level (dBμV/m)	Over Limit (dB)	Limit Line (dBμV/m)	Read Level (dBμV)	Antenna Factor (dB/m)	Cable Loss (dB)	Preamp Factor (dB)	Ant Pos (cm)	Table Pos (deg)	Peak Avg. (P/A)	Pol. (H/V)	
802.11n HT20 CH 36 5180MHz		10360	45.69	-28.31	74	57.15	39.69	11.96	63.11	100	0	P	H	
		15540	43.75	-30.25	74	51.14	38.04	14.76	60.19	100	0	P	H	
													H	
													H	
			10360	45.51	-28.49	74	56.97	39.69	11.96	63.11	100	0	P	V
			15540	43.55	-30.45	74	50.94	38.04	14.76	60.19	100	0	P	V
														V
802.11n HT20 CH 44 5220MHz		10440	45.93	-28.07	74	57.16	39.79	12.03	63.05	100	0	P	H	
		15660	44.7	-29.3	74	52.23	37.85	14.79	60.17	100	0	P	H	
													H	
													H	
			10440	45.47	-28.53	74	56.7	39.79	12.03	63.05	100	0	P	V
			15660	44.3	-29.7	74	51.83	37.85	14.79	60.17	100	0	P	V
														V
802.11n HT20 CH 48 5240MHz		10480	45.75	-28.25	74	56.83	39.87	12.06	63.01	100	0	P	H	
		15720	44.13	-29.87	74	51.74	37.74	14.81	60.16	100	0	P	H	
													H	
													H	
			10480	46.1	-27.9	74	57.18	39.87	12.06	63.01	100	0	P	V
			15720	42.96	-31.04	74	50.57	37.74	14.81	60.16	100	0	P	V
														V
Remark	1. No other spurious found.													
	2. All results are PASS against Peak and Average limit line.													



Emission below 1GHz

WIFI 802.11n HT20 (LF @ 3m)

WIFI	Note	Frequency	Level	Over	Limit	Read	Antenna	Cable	Preamp	Ant	Table	Peak	Pol.	
Ant.				Limit	Line	Level	Factor	Loss	Factor	Pos	Pos	Avg.		
1		(MHz)	(dBμV/m)	(dB)	(dBμV/m)	(dBμV)	(dB/m)	(dB)	(dB)	(cm)	(deg)	(P/A)	(H/V)	
802.11n HT20 LF		32.7	15.77	-24.23	40	29.55	18.38	0.65	32.81			P	H	
		216.03	14.71	-31.29	46	35.54	10.28	1.62	32.73			P	H	
		269.49	19.53	-26.47	46	37	13.5	1.76	32.73			P	H	
		407.8	22.61	-23.39	46	36.68	16.62	2.16	32.85			P	H	
		456.1	22.8	-23.2	46	35.99	17.4	2.3	32.89	121	147	P	H	
		961.5	25.84	-28.16	54	29.94	24.25	3.29	31.64			P	H	
													H	
													H	
													H	
													H	
													H	
													H	
													H	
			54.3	22.61	-17.39	40	46.49	7.96	0.93	32.77	100	59	P	V
			71.04	22.45	-17.55	40	47.42	6.82	0.93	32.72			P	V
			264.09	17.84	-28.16	46	35.07	13.74	1.76	32.73			P	V
			407.8	18.13	-27.87	46	32.2	16.62	2.16	32.85			P	V
			638.8	21.54	-24.46	46	31.86	20.07	2.62	33.01			P	V
			836.2	24.39	-21.61	46	31.6	22.39	3.07	32.67			P	V
														V
													V	
													V	
													V	
													V	
													V	
Remark	1. No other spurious found. 2. All results are PASS against limit line.													



Band 1 - 5150~5250MHz

WIFI 802.11a (Band Edge @ 3m)

WIFI	Note	Frequency	Level	Over	Limit	Read	Antenna	Cable	Preamp	Ant	Table	Peak	Pol.	
Ant.				Limit	Line	Level	Factor	Loss	Factor	Pos	Pos	Avg.		
2		(MHz)	(dBμV/m)	(dB)	(dBμV/m)	(dBμV)	(dB/m)	(dB)	(dB)	(cm)	(deg)	(P/A)	(H/V)	
802.11a CH 36 5180MHz		5148.95	63.77	-10.23	74	56.08	31.98	7.94	32.23	185	297	P	H	
		5150	52.56	-1.44	54	44.87	31.98	7.94	32.23	185	297	A	H	
	*	5182	111.89	-	-	104.18	32.02	7.91	32.22	185	297	P	H	
	*	5182	104.89	-	-	97.18	32.02	7.91	32.22	185	297	A	H	
													H	
														H
			5150	62.8	-11.2	74	55.11	31.98	7.94	32.23	371	70	P	V
			5150	51.19	-2.81	54	43.5	31.98	7.94	32.23	371	70	A	V
	*		5178	109.55	-	-	101.84	32.02	7.91	32.22	371	70	P	V
	*		5178	102.55	-	-	94.84	32.02	7.91	32.22	371	70	A	V
														V
														V
802.11a CH 44 5220MHz		5148.5	53.94	-20.06	74	46.25	31.98	7.94	32.23	189	299	P	H	
		5150	43.72	-10.28	54	36.03	31.98	7.94	32.23	189	299	A	H	
	*	5218	114.64	-	-	106.78	32.06	8.01	32.21	189	299	P	H	
	*	5218	107.44	-	-	99.58	32.06	8.01	32.21	189	299	A	H	
			5384.87	51.59	-22.41	74	43.21	32.26	8.29	32.17	189	299	P	H
			5350	42.16	-11.84	54	33.89	32.22	8.23	32.18	189	299	A	H
			5141.75	52.89	-21.11	74	45.2	31.98	7.94	32.23	381	72	P	V
			5150	42.74	-11.26	54	35.05	31.98	7.94	32.23	381	72	A	V
	*		5221	113.7	-	-	105.84	32.06	8.01	32.21	381	72	P	V
	*		5221	106.2	-	-	98.34	32.06	8.01	32.21	381	72	A	V
			5411.27	51.94	-22.06	74	43.54	32.28	8.29	32.17	381	72	P	V
			5413.36	42.12	-11.88	54	33.69	32.3	8.29	32.16	381	72	A	V



802.11a CH 48 5240MHz		5148.2	52.21	-21.79	74	44.52	31.98	7.94	32.23	195	294	P	H
		5149.4	42.77	-11.23	54	35.08	31.98	7.94	32.23	195	294	A	H
	*	5242	114.72	-	-	106.71	32.1	8.12	32.21	195	294	P	H
	*	5242	107.52	-	-	99.51	32.1	8.12	32.21	195	294	A	H
		5356.16	52	-22	74	43.73	32.22	8.23	32.18	195	294	P	H
		5350.11	42.37	-11.63	54	34.1	32.22	8.23	32.18	195	294	A	H
		5144.45	51.53	-22.47	74	43.84	31.98	7.94	32.23	377	75	P	V
		5142.5	42.02	-11.98	54	34.33	31.98	7.94	32.23	377	75	A	V
	*	5242	112.34	-	-	104.33	32.1	8.12	32.21	377	75	P	V
	*	5242	105.34	-	-	97.33	32.1	8.12	32.21	377	75	A	V
		5386.85	51.44	-22.56	74	43.06	32.26	8.29	32.17	377	75	P	V
		5350	42.07	-11.93	54	33.8	32.22	8.23	32.18	377	75	A	V
Remark	1. No other spurious found. 2. All results are PASS against Peak and Average limit line.												



Band 1 5150~5250MHz

WIFI 802.11a (Harmonic @ 3m)

WIFI Ant. 2	Note	Frequency (MHz)	Level (dBμV/m)	Over Limit (dB)	Limit Line (dBμV/m)	Read Level (dBμV)	Antenna Factor (dB/m)	Cable Loss (dB)	Preamp Factor (dB)	Ant Pos (cm)	Table Pos (deg)	Peak Avg. (P/A)	Pol. (H/V)
802.11a CH 36 5180MHz		10360	46.14	-27.86	74	57.6	39.69	11.96	63.11	100	0	P	H
		15540	43.94	-30.06	74	51.33	38.04	14.76	60.19	100	0	P	H
													H
													H
		10360	45.56	-28.44	74	57.02	39.69	11.96	63.11	100	0	P	V
		15540	44.35	-29.65	74	51.74	38.04	14.76	60.19	100	0	P	V
													V
													V
802.11a CH 44 5220MHz		10440	46.59	-27.41	74	57.82	39.79	12.03	63.05	100	0	P	H
		15660	45.58	-28.42	74	53.11	37.85	14.79	60.17	100	0	P	H
													H
													H
		10440	45.77	-28.23	74	57	39.79	12.03	63.05	100	0	P	V
		15660	45.04	-28.96	74	52.57	37.85	14.79	60.17	100	0	P	V
													V
													V
802.11a CH 48 5240MHz		10479	45.44	-28.56	74	56.52	39.87	12.06	63.01	100	0	P	H
		15720	43.28	-30.72	74	50.89	37.74	14.81	60.16	100	0	P	H
													H
													H
		10479	46.38	-27.62	74	57.46	39.87	12.06	63.01	100	0	P	V
		15720	43.91	-30.09	74	51.52	37.74	14.81	60.16	100	0	P	V
													V
													V
Remark	1. No other spurious found. 2. All results are PASS against Peak and Average limit line.												



Band 1 5150~5250MHz

WIFI 802.11n HT20 (Band Edge @ 3m)

WIFI Ant. 2	Note	Frequency (MHz)	Level (dBμV/m)	Over Limit (dB)	Limit Line (dBμV/m)	Read Level (dBμV)	Antenna Factor (dB/m)	Cable Loss (dB)	Preamp Factor (dB)	Ant Pos (cm)	Table Pos (deg)	Peak Avg. (P/A)	Pol. (H/V)	
802.11n HT20 CH 36 5180MHz		5147.9	62.71	-11.29	74	55.02	31.98	7.94	32.23	184	296	P	H	
		5150	52.47	-1.53	54	44.78	31.98	7.94	32.23	184	296	A	H	
	*	5182	110.39	-	-	102.68	32.02	7.91	32.22	184	296	P	H	
	*	5182	103.19	-	-	95.48	32.02	7.91	32.22	184	296	A	H	
													H	
													H	
			5149.7	62.75	-11.25	74	55.06	31.98	7.94	32.23	371	69	P	V
			5150	51.74	-2.26	54	44.05	31.98	7.94	32.23	371	69	A	V
		*	5182	109.67	-	-	101.96	32.02	7.91	32.22	371	69	P	V
		*	5182	102.57	-	-	94.86	32.02	7.91	32.22	371	69	A	V
													V	
													V	
802.11n HT20 CH 44 5220MHz		5139.05	52.76	-21.24	74	45.1	31.96	7.94	32.24	189	295	P	H	
		5149.55	44.45	-9.55	54	36.76	31.98	7.94	32.23	189	295	A	H	
	*	5222	112.69	-	-	104.83	32.06	8.01	32.21	189	295	P	H	
	*	5222	105.69	-	-	97.83	32.06	8.01	32.21	189	295	A	H	
			5457.36	51.66	-22.34	74	43.18	32.34	8.29	32.15	189	295	P	H
			5350.22	42.97	-11.03	54	34.7	32.22	8.23	32.18	189	295	A	H
			5136.2	51.83	-22.17	74	44.17	31.96	7.94	32.24	381	70	P	V
			5146.4	43.41	-10.59	54	35.72	31.98	7.94	32.23	381	70	A	V
		*	5218	112.12	-	-	104.26	32.06	8.01	32.21	381	70	P	V
		*	5218	101.02	-	-	93.16	32.06	8.01	32.21	381	70	A	V
		5358.91	51.35	-22.65	74	43.08	32.22	8.23	32.18	381	70	P	V	
		5366.39	42.55	-11.45	54	34.19	32.24	8.29	32.17	381	70	A	V	



802.11n HT20 CH 48 5240MHz		5031.2	52.18	-21.82	74	44.58	31.84	8.02	32.26	199	297	P	H
		5081.9	43.46	-10.54	54	35.85	31.9	7.96	32.25	199	297	A	H
	*	5242	114.03	-	-	106.02	32.1	8.12	32.21	199	297	P	H
	*	5242	107.03	-	-	99.02	32.1	8.12	32.21	199	297	A	H
		5416.66	52.1	-21.9	74	43.67	32.3	8.29	32.16	199	297	P	H
		5351.87	43.17	-10.83	54	34.9	32.22	8.23	32.18	199	297	A	H
		5144.3	52.23	-21.77	74	44.54	31.98	7.94	32.23	376	70	P	V
		5141.6	42.78	-11.22	54	35.09	31.98	7.94	32.23	376	70	A	V
	*	5242	112.48	-	-	104.47	32.1	8.12	32.21	376	70	P	V
	*	5242	105.48	-	-	97.47	32.1	8.12	32.21	376	70	A	V
		5356.16	51.8	-22.2	74	43.53	32.22	8.23	32.18	376	70	P	V
		5351.43	42.86	-11.14	54	34.59	32.22	8.23	32.18	376	70	A	V
Remark	1. No other spurious found. 2. All results are PASS against Peak and Average limit line.												



Band 1 5150~5250MHz

WIFI 802.11n HT20 (Harmonic @ 3m)

WIFI Ant. 2	Note	Frequency (MHz)	Level (dBµV/m)	Over Limit (dB)	Limit Line (dBµV/m)	Read Level (dBµV)	Antenna Factor (dB/m)	Cable Loss (dB)	Preamp Factor (dB)	Ant Pos (cm)	Table Pos (deg)	Peak Avg. (P/A)	Pol. (H/V)
802.11n HT20 CH 36 5180MHz		10360	45.56	-28.44	74	57.02	39.69	11.96	63.11	100	0	P	H
		15540	44.56	-29.44	74	51.95	38.04	14.76	60.19	100	0	P	H
													H
													H
		10360	45.31	-28.69	74	56.77	39.69	11.96	63.11	100	0	P	V
		15540	43.73	-30.27	74	51.12	38.04	14.76	60.19	100	0	P	V
													V
802.11n HT20 CH 44 5220MHz		10440	46.11	-27.89	74	57.34	39.79	12.03	63.05	100	0	P	H
		15660	44.96	-29.04	74	52.49	37.85	14.79	60.17	100	0	P	H
													H
													H
		10440	46.41	-27.59	74	57.64	39.79	12.03	63.05	100	0	P	V
		15660	44.05	-29.95	74	51.58	37.85	14.79	60.17	100	0	P	V
													V
802.11n HT20 CH 48 5240MHz		10480	46.2	-27.8	74	57.28	39.87	12.06	63.01	100	0	P	H
		15720	43.47	-30.53	74	51.08	37.74	14.81	60.16	100	0	P	H
													H
													H
		10480	45.57	-28.43	74	56.65	39.87	12.06	63.01	100	0	P	V
		15720	43.11	-30.89	74	50.72	37.74	14.81	60.16	100	0	P	V
													V
Remark	1. No other spurious found.												
	2. All results are PASS against Peak and Average limit line.												



Emission below 1GHz

WIFI 802.11n HT20 (LF @ 3m)

WIFI	Note	Frequency	Level	Over	Limit	Read	Antenna	Cable	Preamp	Ant	Table	Peak	Pol.	
Ant.				Limit	Line	Level	Factor	Loss	Factor	Pos	Pos	Avg.		
2		(MHz)	(dBμV/m)	(dB)	(dBμV/m)	(dBμV)	(dB/m)	(dB)	(dB)	(cm)	(deg)	(P/A)	(H/V)	
802.11n HT20 LF		122.88	19.1	-24.4	43.5	38.68	11.93	1.14	32.65			P	H	
		220.08	22.13	-23.87	46	43.04	10.2	1.62	32.73			P	H	
		260.04	22.74	-23.26	46	39.81	13.9	1.76	32.73			P	H	
		311.9	20.41	-25.59	46	37.12	14.15	1.88	32.74			P	H	
		456.1	20.57	-25.43	46	33.76	17.4	2.3	32.89			P	H	
		951	26.46	-19.54	46	30.62	24.3	3.29	31.75	131	29	P	H	
													H	
													H	
													H	
													H	
													H	
													H	
			41.61	31.3	-8.7	40	50.07	13.38	0.65	32.8	100	314	P	V
			216.03	20.8	-25.2	46	41.63	10.28	1.62	32.73			P	V
			234.93	22.3	-23.7	46	41.91	11.5	1.62	32.73			P	V
			600.3	20.2	-25.8	46	31.06	19.6	2.57	33.03			P	V
			839.7	24.66	-21.34	46	31.82	22.42	3.07	32.65			P	V
			996.5	26.91	-27.09	54	30.66	24.12	3.38	31.25			P	V
														V
														V
													V	
													V	
													V	
													V	
Remark	1. No other spurious found. 2. All results are PASS against limit line.													



Note symbol

*	Fundamental Frequency which can be ignored. However, the level of any unwanted emissions shall not exceed the level of the fundamental frequency.
!	Test result is over limit line.
P/A	Peak or Average
H/V	Horizontal or Vertical



A calculation example for radiated spurious emission is shown as below:

WIFI	Note	Frequency	Level	Over	Limit	Read	Antenna	Cable	Preamp	Ant	Table	Peak	Pol.
Ant.				Limit	Line	Level	Factor	Loss	Factor	Pos	Pos	Avg.	
1		(MHz)	(dBμV/m)	(dB)	(dBμV/m)	(dBμV)	(dB/m)	(dB)	(dB)	(cm)	(deg)	(P/A)	(H/V)
802.11b		2390	55.45	-18.55	74	54.51	32.22	4.58	35.86	103	308	P	H
CH 01													
2412MHz		2390	43.54	-10.46	54	42.6	32.22	4.58	35.86	103	308	A	H

- Level(dBμV/m) =
Antenna Factor(dB/m) + Cable Loss(dB) + Read Level(dBμV) - Preamp Factor(dB)
- Over Limit(dB) = Level(dBμV/m) – Limit Line(dBμV/m)

For Peak Limit @ 2390MHz:

- Level(dBμV/m)
= Antenna Factor(dB/m) + Cable Loss(dB) + Read Level(dBμV) - Preamp Factor(dB)
= 32.22(dB/m) + 4.58(dB) + 54.51(dBμV) – 35.86 (dB)
= 55.45 (dBμV/m)
- Over Limit(dB)
= Level(dBμV/m) – Limit Line(dBμV/m)
= 55.45(dBμV/m) – 74(dBμV/m)
= -18.55(dB)

For Average Limit @ 2390MHz:

- Level(dBμV/m)
= Antenna Factor(dB/m) + Cable Loss(dB) + Read Level(dBμV) - Preamp Factor(dB)
= 32.22(dB/m) + 4.58(dB) + 42.6(dBμV) – 35.86 (dB)
= 43.54 (dBμV/m)
- Over Limit(dB)
= Level(dBμV/m) – Limit Line(dBμV/m)
= 43.54(dBμV/m) – 54(dBμV/m)
= -10.46(dB)

Both peak and average measured complies with the limit line, so test result is “PASS”.



Appendix C. Radiated Spurious Emission

Note symbol

-L	Low channel location
-R	High channel location



Band 1 - 5150~5250MHz

WIFI 802.11a (Band Edge @ 3m)

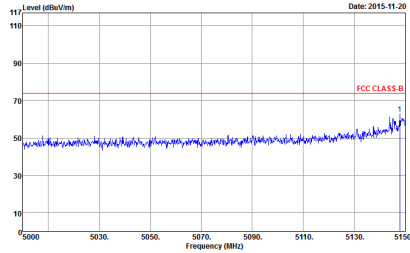
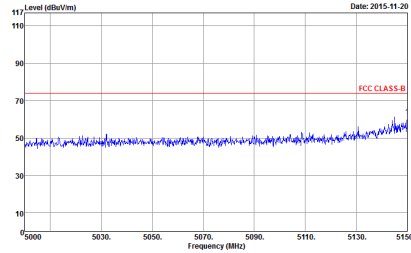
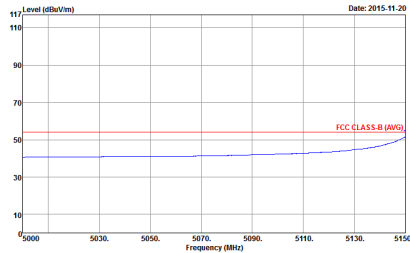
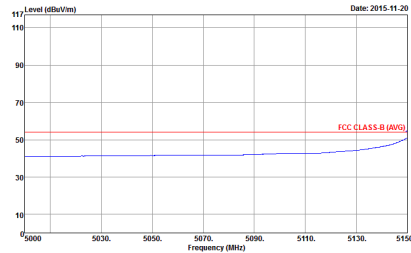
WIFI	Band 1 5150~5250MHz Band Edge @ 3m	
ANT	802.11a CH36 5180MHz	
<p>1</p> <p>Peak</p>	<p style="text-align: center;">Horizontal</p>  <p>Site : 03CH10-HY Condition : FCC CLASS-B 3m HORN 9120D-HF HORIZONTAL Detector : Peak Project : 3N0602-02 Mode : 7</p>	<p style="text-align: center;">Vertical</p>  <p>Site : 03CH10-HY Condition : FCC CLASS-B 3m HORN 9120D-HF VERTICAL Detector : Peak Project : 3N0602-02 Mode : 7</p>
<p>Avg.</p>	 <p>Site : 03CH10-HY Condition : FCC CLASS-B (AVG) 3m HORN 9120D-HF HORIZONTAL Detector : Peak Project : 3N0602-02 Mode : 7</p>	 <p>Site : 03CH10-HY Condition : FCC CLASS-B (AVG) 3m HORN 9120D-HF VERTICAL Detector : Peak Project : 3N0602-02 Mode : 7</p>

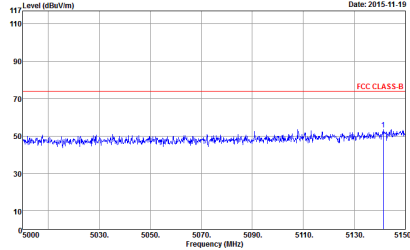
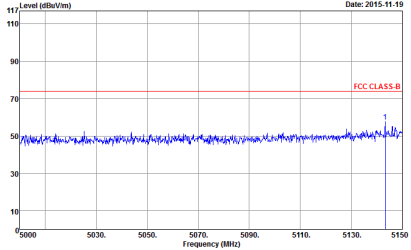
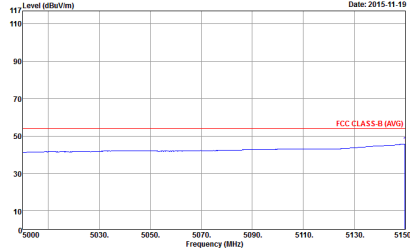
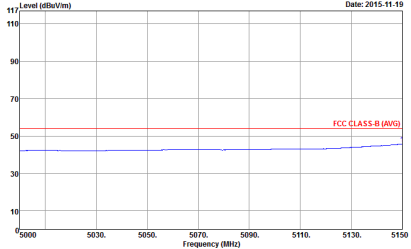

WIFI	Band 1 5150~5250MHz Band Edge @ 3m	
ANT	802.11a CH44 5220MHz - L	
1	Horizontal	Vertical
Peak	 <p>Site : 03CH10-HY Condition : FCC CLASS-B 3m HORN 9120D-HF HORIZONTAL Detector : Peak Project : 3N0602-02 Mode : 8</p>	 <p>Site : 03CH10-HY Condition : FCC CLASS-B 3m HORN 9120D-HF VERTICAL Detector : Peak Project : 3N0602-02 Mode : 8</p>
Avg.	 <p>Site : 03CH10-HY Condition : FCC CLASS-B (AVG) 3m HORN 9120D-HF HORIZONTAL Detector : Peak Project : 3N0602-02 Mode : 8</p>	 <p>Site : 03CH10-HY Condition : FCC CLASS-B (AVG) 3m HORN 9120D-HF VERTICAL Detector : Peak Project : 3N0602-02 Mode : 8</p>

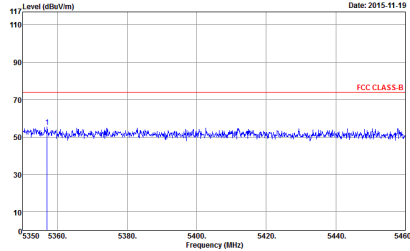
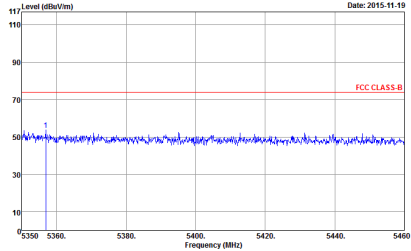
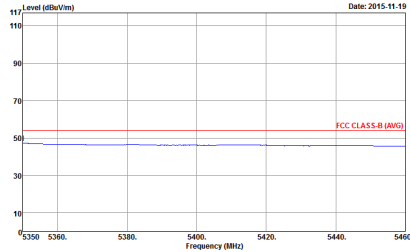
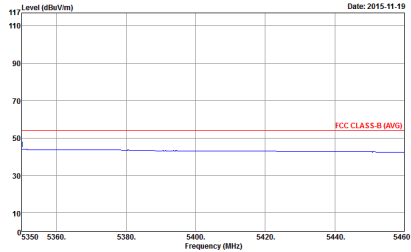

WIFI	Band 1 5150~5250MHz Band Edge @ 3m	
ANT	802.11a CH44 5220MHz - R	
1	Horizontal	Vertical
Peak	 <p>Date: 2015-11-19</p> <p>Level (dBuV/m)</p> <p>Frequency (MHz)</p> <p>FCC CLASS-B</p> <p>Site : 03CH10-HY Condition : FCC CLASS-B 3m HORN 9120D-HF HORIZONTAL RBW:1000.000KHz VBW:3000.000KHz SWT:Auto Detector : Peak Project : 3N0602-02 Mode : 8</p>	 <p>Date: 2015-11-19</p> <p>Level (dBuV/m)</p> <p>Frequency (MHz)</p> <p>FCC CLASS-B</p> <p>Site : 03CH10-HY Condition : FCC CLASS-B 3m HORN 9120D-HF VERTICAL RBW:1000.000KHz VBW:3000.000KHz SWT:Auto Detector : Peak Project : 3N0602-02 Mode : 8</p>
Avg.	 <p>Date: 2015-11-19</p> <p>Level (dBuV/m)</p> <p>Frequency (MHz)</p> <p>FCC CLASS-B (AVG)</p> <p>Site : 03CH10-HY Condition : FCC CLASS-B (AVG) 3m HORN 9120D-HF HORIZONTAL RBW:1000.000KHz VBW:0.010KHz SWT:Auto Detector : Peak Project : 3N0602-02 Mode : 8</p>	 <p>Date: 2015-11-19</p> <p>Level (dBuV/m)</p> <p>Frequency (MHz)</p> <p>FCC CLASS-B (AVG)</p> <p>Site : 03CH10-HY Condition : FCC CLASS-B (AVG) 3m HORN 9120D-HF VERTICAL RBW:1000.000KHz VBW:0.010KHz SWT:Auto Detector : Peak Project : 3N0602-02 Mode : 8</p>

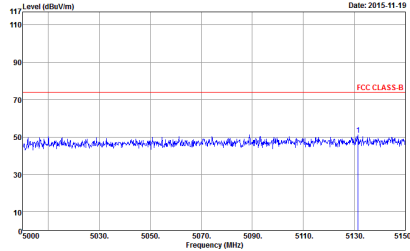
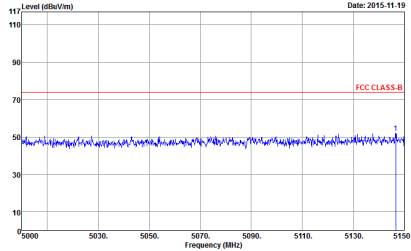
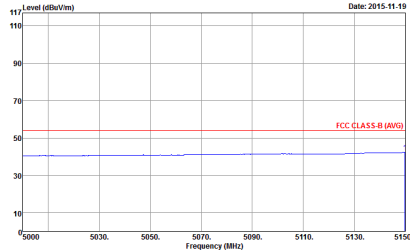
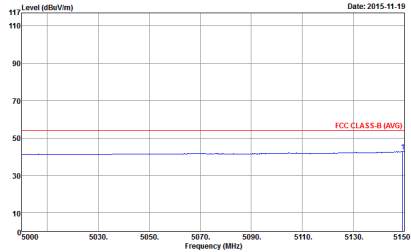

WIFI	Band 1 5150~5250MHz Band Edge @ 3m	
ANT	802.11a CH48 5240MHz - L	
1	Horizontal	Vertical
Peak	 <p>Site : 03CH10-#Y Condition : FCC CLASS-B 3m HORN 9120D-HF HORIZONTAL RBW:1000.000KHz VBW:3000.000KHz SWT:Auto Detector : Peak Project : 3N0602-02 Mode : 9</p>	 <p>Site : 03CH10-#Y Condition : FCC CLASS-B 3m HORN 9120D-HF VERTICAL RBW:1000.000KHz VBW:3000.000KHz SWT:Auto Detector : Peak Project : 3N0602-02 Mode : 9</p>
Avg.	 <p>Site : 03CH10-#Y Condition : FCC CLASS-B (AVG) 3m HORN 9120D-HF HORIZONTAL RBW:1000.000KHz VBW:0.010KHz SWT:Auto Detector : Peak Project : 3N0602-02 Mode : 9</p>	 <p>Site : 03CH10-#Y Condition : FCC CLASS-B (AVG) 3m HORN 9120D-HF VERTICAL RBW:1000.000KHz VBW:0.010KHz SWT:Auto Detector : Peak Project : 3N0602-02 Mode : 9</p>

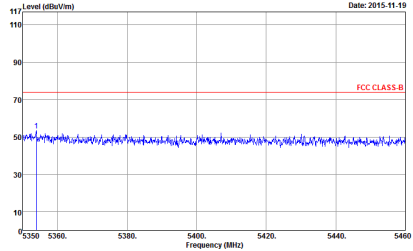
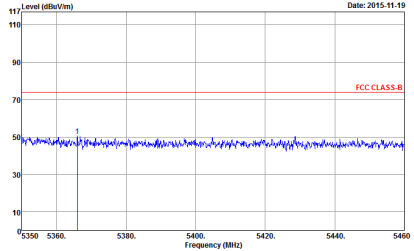
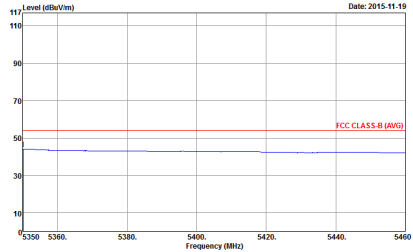
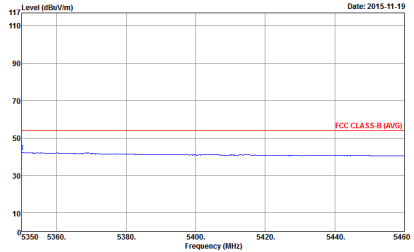

WIFI	Band 1 5150~5250MHz Band Edge @ 3m	
ANT	802.11a CH48 5240MHz - R	
1	Horizontal	Vertical
Peak	 <p>Level (dBuV/m) vs Frequency (MHz) for Horizontal orientation. The plot shows a blue signal line fluctuating around 50 dBuV/m, with a red horizontal line at 70 dBuV/m labeled 'FCC CLASS-B'. The x-axis ranges from 5350 to 5460 MHz, and the y-axis ranges from 10 to 110 dBuV/m.</p> <p>Site : 03CH10-HY Condition : FCC CLASS-B 3m HORN 9120D-HF HORIZONTAL RBW:1000.000KHz VBW:3000.000KHz SWT:Auto Detector : Peak Project : 3N0602-02 Mode : 9</p>	 <p>Level (dBuV/m) vs Frequency (MHz) for Vertical orientation. The plot shows a blue signal line fluctuating around 50 dBuV/m, with a red horizontal line at 70 dBuV/m labeled 'FCC CLASS-B'. The x-axis ranges from 5350 to 5460 MHz, and the y-axis ranges from 10 to 110 dBuV/m.</p> <p>Site : 03CH10-HY Condition : FCC CLASS-B 3m HORN 9120D-HF VERTICAL RBW:1000.000KHz VBW:3000.000KHz SWT:Auto Detector : Peak Project : 3N0602-02 Mode : 9</p>
Avg.	 <p>Level (dBuV/m) vs Frequency (MHz) for Horizontal orientation (Average). The plot shows a blue signal line fluctuating around 45 dBuV/m, with a red horizontal line at 55 dBuV/m labeled 'FCC CLASS-B (AVG)'. The x-axis ranges from 5350 to 5460 MHz, and the y-axis ranges from 10 to 110 dBuV/m.</p> <p>Site : 03CH10-HY Condition : FCC CLASS-B (AVG) 3m HORN 9120D-HF HORIZONTAL RBW:1000.000KHz VBW:0.010KHz SWT:Auto Detector : Peak Project : 3N0602-02 Mode : 9</p>	 <p>Level (dBuV/m) vs Frequency (MHz) for Vertical orientation (Average). The plot shows a blue signal line fluctuating around 45 dBuV/m, with a red horizontal line at 55 dBuV/m labeled 'FCC CLASS-B (AVG)'. The x-axis ranges from 5350 to 5460 MHz, and the y-axis ranges from 10 to 110 dBuV/m.</p> <p>Site : 03CH10-HY Condition : FCC CLASS-B (AVG) 3m HORN 9120D-HF VERTICAL RBW:1000.000KHz VBW:0.010KHz SWT:Auto Detector : Peak Project : 3N0602-02 Mode : 9</p>

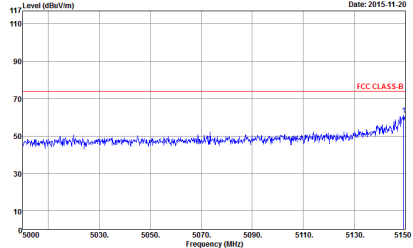
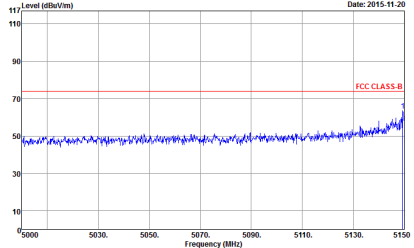
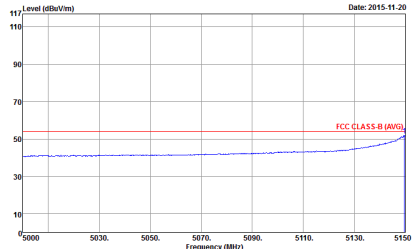
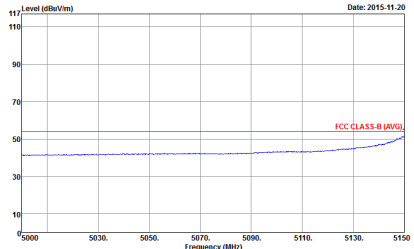

Band 1 5150~5250MHz
WIFI 802.11n HT20 (Band Edge @ 3m)

WIFI	Band 1 5150~5250MHz Band Edge @ 3m	
ANT	802.11n HT20 CH36 5180MHz	
1	Horizontal	Vertical
<p>Peak</p>	 <p>Site : 03CH10-HY Condition : FCC CLASS-B 3m HORN 9120D-HF HORIZONTAL Detector : Peak Project : 3N0602-02 Mode : IO</p>	 <p>Site : 03CH10-HY Condition : FCC CLASS-B 3m HORN 9120D-HF VERTICAL Detector : Peak Project : 3N0602-02 Mode : IO</p>
<p>Avg.</p>	 <p>Site : 03CH10-HY Condition : FCC CLASS-B (AVG) 3m HORN 9120D-HF HORIZONTAL Detector : Peak Project : 3N0602-02 Mode : IO</p>	 <p>Site : 03CH10-HY Condition : FCC CLASS-B (AVG) 3m HORN 9120D-HF VERTICAL Detector : Peak Project : 3N0602-02 Mode : IO</p>

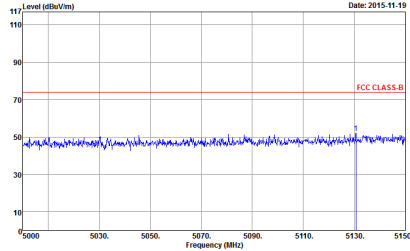
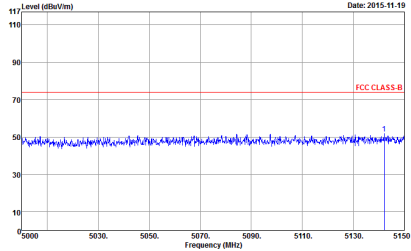
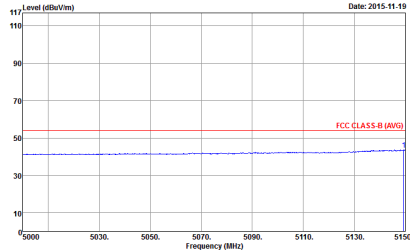
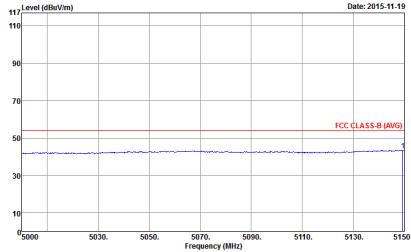

WIFI	Band 1 5150~5250MHz Band Edge @ 3m	
ANT	802.11n HT20 CH44 5220MHz - L	
1	Horizontal	Vertical
Peak	 <p>Site : 03CH10-HY Condition : FCC CLASS-B 3m HORN 9120D-HF HORIZONTAL Detector : Peak Project : 3N0602-02 Mode : II</p>	 <p>Site : 03CH10-HY Condition : FCC CLASS-B 3m HORN 9120D-HF VERTICAL Detector : Peak Project : 3N0602-02 Mode : II</p>
Avg.	 <p>Site : 03CH10-HY Condition : FCC CLASS-B (AVG) 3m HORN 9120D-HF HORIZONTAL Detector : Peak Project : 3N0602-02 Mode : II</p>	 <p>Site : 03CH10-HY Condition : FCC CLASS-B (AVG) 3m HORN 9120D-HF VERTICAL Detector : Peak Project : 3N0602-02 Mode : II</p>

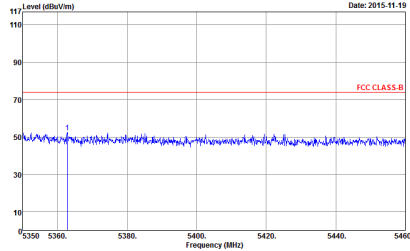
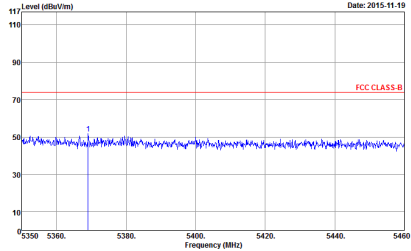
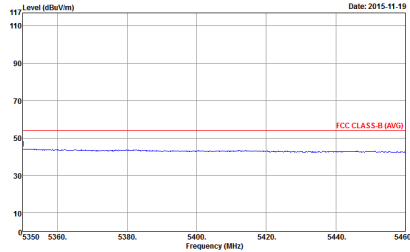
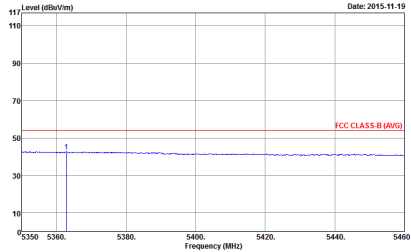

WIFI	Band 1 5150~5250MHz Band Edge @ 3m	
ANT	802.11n HT20 CH44 5220MHz - R	
1	Horizontal	Vertical
Peak	 <p>Date: 2015-11-19</p> <p>Level (dBuV/m)</p> <p>Frequency (MHz)</p> <p>FCC CLASS-B</p> <p>Site : 03CH10-HY Condition : FCC CLASS-B 3m HORN 9120D-HF HORIZONTAL RBW:1000.000KHz VBW:3000.000KHz SWT:Auto Detector : Peak Project : 3N0602-02 Mode : II</p>	 <p>Date: 2015-11-19</p> <p>Level (dBuV/m)</p> <p>Frequency (MHz)</p> <p>FCC CLASS-B</p> <p>Site : 03CH10-HY Condition : FCC CLASS-B 3m HORN 9120D-HF VERTICAL RBW:1000.000KHz VBW:3000.000KHz SWT:Auto Detector : Peak Project : 3N0602-02 Mode : II</p>
Avg.	 <p>Date: 2015-11-19</p> <p>Level (dBuV/m)</p> <p>Frequency (MHz)</p> <p>FCC CLASS-B (AVG)</p> <p>Site : 03CH10-HY Condition : FCC CLASS-B (AVG) 3m HORN 9120D-HF HORIZONTAL RBW:1000.000KHz VBW:1000KHz SWT:Auto Detector : Peak Project : 3N0602-02 Mode : II</p>	 <p>Date: 2015-11-19</p> <p>Level (dBuV/m)</p> <p>Frequency (MHz)</p> <p>FCC CLASS-B (AVG)</p> <p>Site : 03CH10-HY Condition : FCC CLASS-B (AVG) 3m HORN 9120D-HF VERTICAL RBW:1000.000KHz VBW:1000KHz SWT:Auto Detector : Peak Project : 3N0602-02 Mode : II</p>

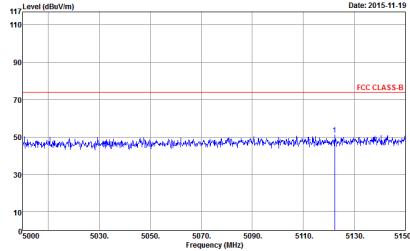
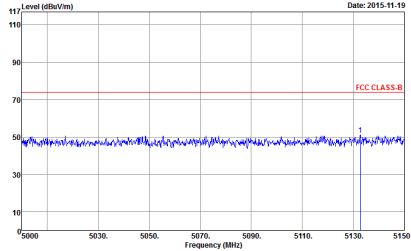
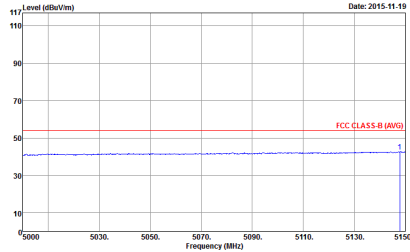
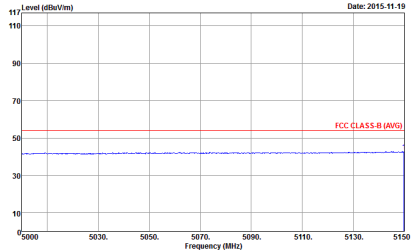

WIFI	Band 1 5150~5250MHz Band Edge @ 3m	
ANT	802.11n HT20 CH48 5240MHz - L	
1	Horizontal	Vertical
Peak	 <p>Date: 2015-11-19</p> <p>Level (dBuV/m)</p> <p>Frequency (MHz)</p> <p>FCC CLASS-B</p> <p>Site : 03CH10-HY Condition : FCC CLASS-B 3m HORN 9120D-HF HORIZONTAL RBW:1000.000KHz VBW:3000.000KHz SWT:Auto Detector : Peak Project : 3N0602-02 Mode : 12</p>	 <p>Date: 2015-11-19</p> <p>Level (dBuV/m)</p> <p>Frequency (MHz)</p> <p>FCC CLASS-B</p> <p>Site : 03CH10-HY Condition : FCC CLASS-B 3m HORN 9120D-HF VERTICAL RBW:1000.000KHz VBW:3000.000KHz SWT:Auto Detector : Peak Project : 3N0602-02 Mode : 12</p>
Avg.	 <p>Date: 2015-11-19</p> <p>Level (dBuV/m)</p> <p>Frequency (MHz)</p> <p>FCC CLASS-B (AVG)</p> <p>Site : 03CH10-HY Condition : FCC CLASS-B (AVG) 3m HORN 9120D-HF HORIZONTAL RBW:1000.000KHz VBW:1000KHz SWT:Auto Detector : Peak Project : 3N0602-02 Mode : 12</p>	 <p>Date: 2015-11-19</p> <p>Level (dBuV/m)</p> <p>Frequency (MHz)</p> <p>FCC CLASS-B (AVG)</p> <p>Site : 03CH10-HY Condition : FCC CLASS-B (AVG) 3m HORN 9120D-HF VERTICAL RBW:1000.000KHz VBW:1000KHz SWT:Auto Detector : Peak Project : 3N0602-02 Mode : 12</p>

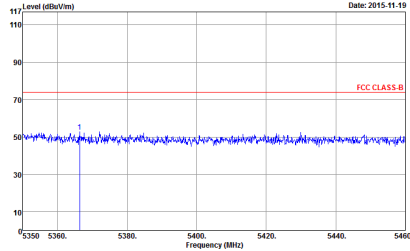
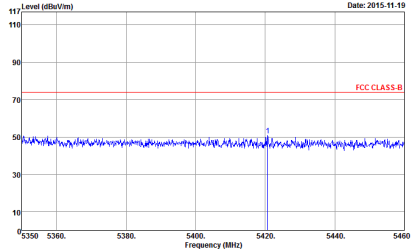
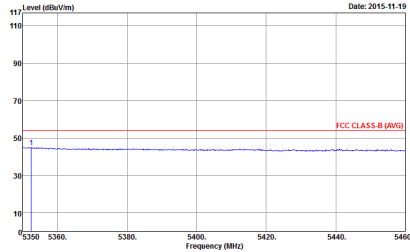
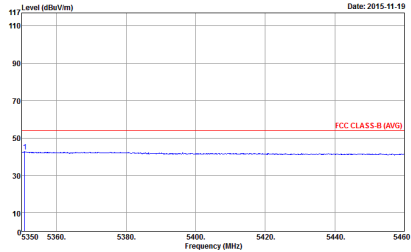

WIFI	Band 1 5150~5250MHz Band Edge @ 3m	
ANT	802.11n HT20 CH48 5240MHz - R	
1	Horizontal	Vertical
Peak	 <p>Date: 2015-11-19</p> <p>Level (dBuV/m)</p> <p>Frequency (MHz)</p> <p>FCC CLASS-B</p> <p>Site : 03CH10-HY Condition : FCC CLASS-B 3m HORN 9120D-HF HORIZONTAL RBW:1000.000KHz VBW:3000.000KHz SWT:Auto Detector : Peak Project : 3N0602-02 Mode : 12</p>	 <p>Date: 2015-11-19</p> <p>Level (dBuV/m)</p> <p>Frequency (MHz)</p> <p>FCC CLASS-B</p> <p>Site : 03CH10-HY Condition : FCC CLASS-B 3m HORN 9120D-HF VERTICAL RBW:1000.000KHz VBW:3000.000KHz SWT:Auto Detector : Peak Project : 3N0602-02 Mode : 12</p>
Avg.	 <p>Date: 2015-11-19</p> <p>Level (dBuV/m)</p> <p>Frequency (MHz)</p> <p>FCC CLASS-B (AVG)</p> <p>Site : 03CH10-HY Condition : FCC CLASS-B (AVG) 3m HORN 9120D-HF HORIZONTAL RBW:1000.000KHz VBW:1000KHz SWT:Auto Detector : Peak Project : 3N0602-02 Mode : 12</p>	 <p>Date: 2015-11-19</p> <p>Level (dBuV/m)</p> <p>Frequency (MHz)</p> <p>FCC CLASS-B (AVG)</p> <p>Site : 03CH10-HY Condition : FCC CLASS-B (AVG) 3m HORN 9120D-HF VERTICAL RBW:1000.000KHz VBW:1000KHz SWT:Auto Detector : Peak Project : 3N0602-02 Mode : 12</p>



Band 1 - 5150~5250MHz

WIFI 802.11a (Harmonic @ 3m)

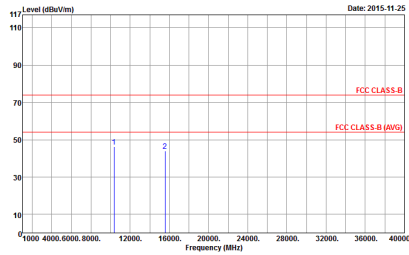
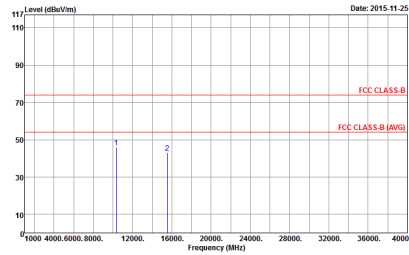
WIFI	Band 1 5150~5250MHz Harmonic @ 3m	
ANT	802.11a CH36 5180MHz	
1	Horizontal	Vertical
Peak Avg.	 <p>Site : 03CH10-HY Condition : FCC CLASS-B 3m HORN 9120D-HF HORIZONTAL Detector : Peak Project : 3N0602-02 Mode : 7</p>	 <p>Site : 03CH10-HY Condition : FCC CLASS-B 3m HORN 9120D-HF VERTICAL Detector : Peak Project : 3N0602-02 Mode : 7</p>

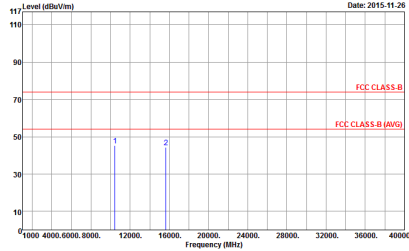
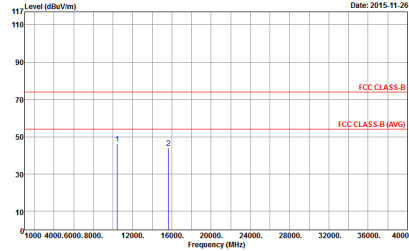

WIFI	Band 1 5150~5250MHz Harmonic @ 3m	
ANT	802.11a CH44 5220MHz	
1	Horizontal	Vertical
<p>Peak</p> <p>Avg.</p>	 <p>Date: 2015-11-26</p> <p>Site : 00CH10-HY Condition : FCC CLASS-B 3m HORN 9120D-HF HORIZONTAL Detector : Peak Project : 3N0602-02 Mode : B</p>	 <p>Date: 2015-11-26</p> <p>Site : 00CH10-HY Condition : FCC CLASS-B 3m HORN 9120D-HF VERTICAL Detector : Peak Project : 3N0602-02 Mode : B</p>

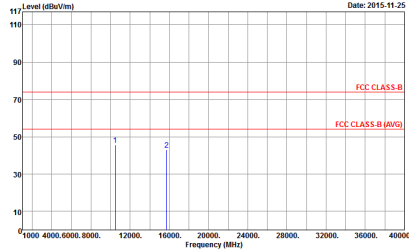
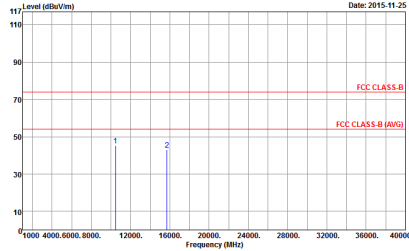

WIFI	Band 1 5150~5250MHz Harmonic @ 3m	
ANT	802.11a CH48 5240MHz	
1	Horizontal	Vertical
<p>Peak</p> <p>Avg.</p>	 <p>Date: 2015-11-25</p> <p>Site : 00CH10-HY Condition : FCC CLASS-B 3m HORN 9120D-HF HORIZONTAL Detector : Peak Project : 3N0602-02 Mode : 9</p>	 <p>Date: 2015-11-25</p> <p>Site : 00CH10-HY Condition : FCC CLASS-B 3m HORN 9120D-HF VERTICAL Detector : Peak Project : 3N0602-02 Mode : 9</p>

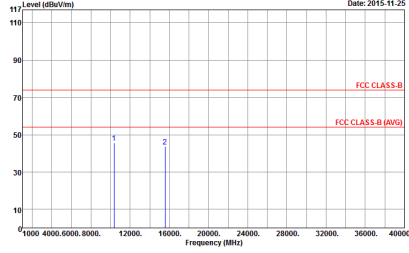
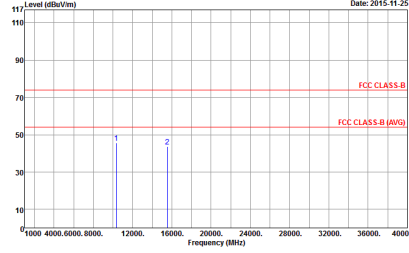

**Band 1 5150~5250MHz
WIFI 802.11n HT20 (Harmonic @ 3m)**

WIFI	Band 1 5150~5250MHz Harmonic @ 3m	
ANT	802.11n HT20 CH36 5180MHz	
1	Horizontal	Vertical
<p>Peak</p> <p>Avg.</p>	 <p>Date: 2015-11-25</p> <p>Site : 03CH10-HY Condition : FCC CLASS-B 3m HORN 9120D-HF HORIZONTAL Detector : Peak Project : 3N0602-02 Mode : 10</p>	 <p>Date: 2015-11-25</p> <p>Site : 03CH10-HY Condition : FCC CLASS-B 3m HORN 9120D-HF VERTICAL Detector : Peak Project : 3N0602-02 Mode : 10</p>

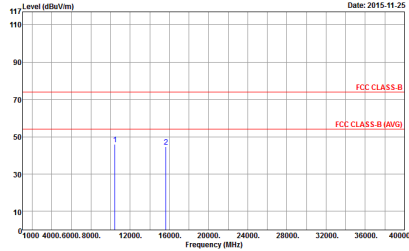
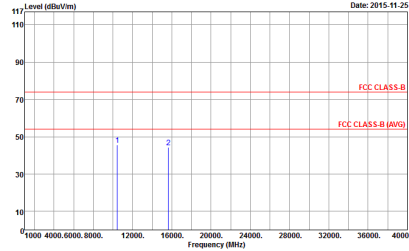

WIFI	Band 1 5150~5250MHz Harmonic @ 3m	
ANT	802.11n HT20 CH44 5220MHz	
1	Horizontal	Vertical
<p>Peak</p> <p>Avg.</p>	 <p>Site : 00CH10-HY Condition : FCC CLASS-B 3m HORN 9120D-HF HORIZONTAL Detector : Peak Project : 3N0602-02 Mode : 11</p>	 <p>Site : 00CH10-HY Condition : FCC CLASS-B 3m HORN 9120D-HF VERTICAL Detector : Peak Project : 3N0602-02 Mode : 11</p>



WIFI	Band 1 5150~5250MHz Harmonic @ 3m	
ANT	802.11n HT20 CH48 5240MHz	
1	Horizontal	Vertical
Peak Avg.	<p>Site : 00CH10-HY Condition : FCC CLASS-B 3m HORN 9120D-HF HORIZONTAL Detector : Peak Project : 3N0602-02 Mode : 12</p>	<p>Site : 00CH10-HY Condition : FCC CLASS-B 3m HORN 9120D-HF VERTICAL Detector : Peak Project : 3N0602-02 Mode : 12</p>



Emission below 1GHz
5GHz WIFI 802.11n HT20 (LF)

WIFI	5GHz WIFI	
ANT	802.11n HT20 LF	
1	Horizontal	Vertical
QP / Peak	<p>Site : 03CH10-HY Condition : FCC CLASS-B 3m BT-LOG 6111D-LF HORIZONTAL Detector : Peak Project : 3N0602-02 Mode : 26</p>	<p>Site : 03CH10-HY Condition : FCC CLASS-B 3m BT-LOG 6111D-LF VERTICAL Detector : Peak Project : 3N0602-02 Mode : 26</p>



Band 1 - 5150~5250MHz

WIFI 802.11a (Band Edge @ 3m)

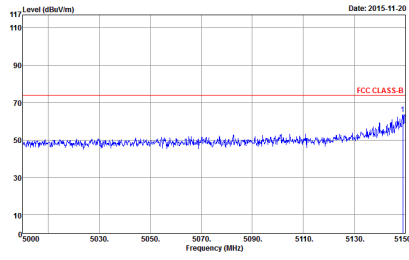
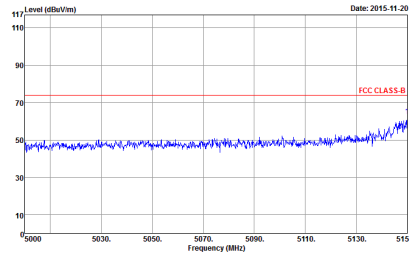
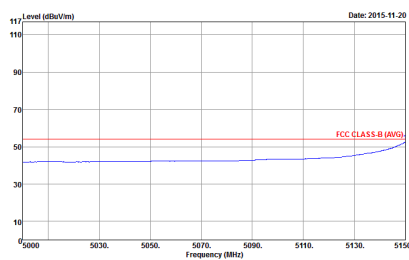
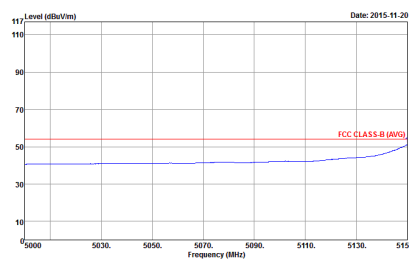
WIFI	Band 1 5150~5250MHz Band Edge @ 3m	
ANT	802.11a CH36 5180MHz	
2	Horizontal	Vertical
Peak	 <p>Site : 03CH10-HY Condition : FCC CLASS-B 3m HORN 9120D-HF HORIZONTAL RBW:1000.000KHz VBW:3000.000KHz SWT:Auto Detector : Peak Project : 3N0602-02 Mode : 19</p>	 <p>Site : 03CH10-HY Condition : FCC CLASS-B 3m HORN 9120D-HF VERTICAL RBW:1000.000KHz VBW:3000.000KHz SWT:Auto Detector : Peak Project : 3N0602-02 Mode : 19</p>
Avg.	 <p>Site : 03CH10-HY Condition : FCC CLASS-B (AVG) 3m HORN 9120D-HF HORIZONTAL RBW:1000.000KHz VBW:0.010KHz SWT:Auto Detector : Peak Project : 3N0602-02 Mode : 19</p>	 <p>Site : 03CH10-HY Condition : FCC CLASS-B (AVG) 3m HORN 9120D-HF VERTICAL RBW:1000.000KHz VBW:0.010KHz SWT:Auto Detector : Peak Project : 3N0602-02 Mode : 19</p>

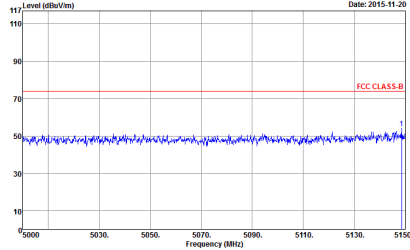
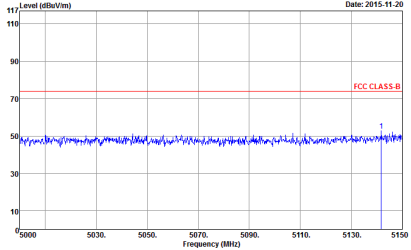
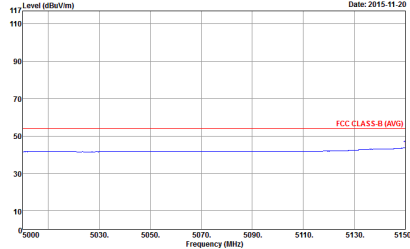
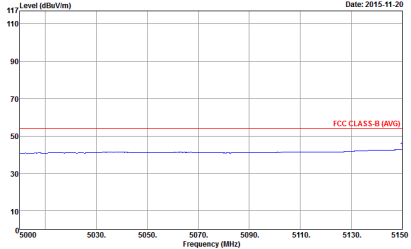

WIFI	Band 1 5150~5250MHz Band Edge @ 3m	
ANT	802.11a CH44 5220MHz - L	
2	Horizontal	Vertical
Peak	 <p>Site : 03CH10-HY Condition : FCC CLASS-B 3m HORN 9120D-HF HORIZONTAL Detector : Peak Project : 3N0602-02 Mode : 20</p>	 <p>Site : 03CH10-HY Condition : FCC CLASS-B 3m HORN 9120D-HF VERTICAL Detector : Peak Project : 3N0602-02 Mode : 20</p>
Avg.	 <p>Site : 03CH10-HY Condition : FCC CLASS-B (AVG) 3m HORN 9120D-HF HORIZONTAL Detector : Peak Project : 3N0602-02 Mode : 20</p>	 <p>Site : 03CH10-HY Condition : FCC CLASS-B (AVG) 3m HORN 9120D-HF VERTICAL Detector : Peak Project : 3N0602-02 Mode : 20</p>

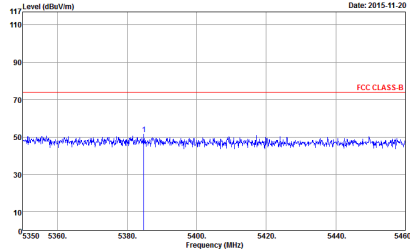
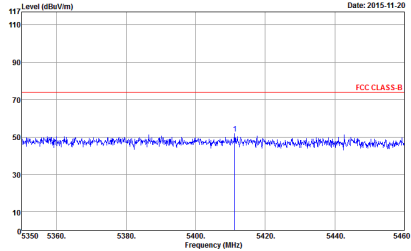
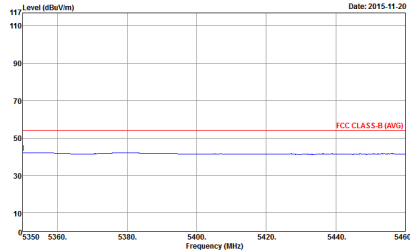
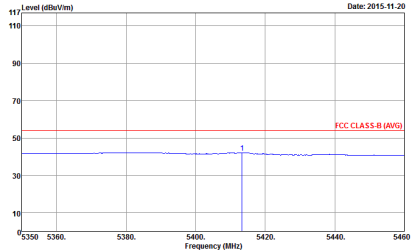

WIFI	Band 1 5150~5250MHz Band Edge @ 3m	
ANT	802.11a CH44 5220MHz - R	
2	Horizontal	Vertical
Peak	 <p>Date: 2015-11-20</p> <p>Level (dBuV/m)</p> <p>Frequency (MHz)</p> <p>FCC CLASS-B</p> <p>Site : 03CH10-HY Condition : FCC CLASS-B 3m HORN 9120D-HF HORIZONTAL RBW:1000.000KHz VBW:3000.000KHz SWT:Auto Detector : Peak Project : 3N0602-02 Mode : 20</p>	 <p>Date: 2015-11-20</p> <p>Level (dBuV/m)</p> <p>Frequency (MHz)</p> <p>FCC CLASS-B</p> <p>Site : 03CH10-HY Condition : FCC CLASS-B 3m HORN 9120D-HF VERTICAL RBW:1000.000KHz VBW:3000.000KHz SWT:Auto Detector : Peak Project : 3N0602-02 Mode : 20</p>
Avg.	 <p>Date: 2015-11-20</p> <p>Level (dBuV/m)</p> <p>Frequency (MHz)</p> <p>FCC CLASS-B (AVG)</p> <p>Site : 03CH10-HY Condition : FCC CLASS-B (AVG) 3m HORN 9120D-HF HORIZONTAL RBW:1000.000KHz VBW:0.010KHz SWT:Auto Detector : Peak Project : 3N0602-02 Mode : 20</p>	 <p>Date: 2015-11-20</p> <p>Level (dBuV/m)</p> <p>Frequency (MHz)</p> <p>FCC CLASS-B (AVG)</p> <p>Site : 03CH10-HY Condition : FCC CLASS-B (AVG) 3m HORN 9120D-HF VERTICAL RBW:1000.000KHz VBW:0.010KHz SWT:Auto Detector : Peak Project : 3N0602-02 Mode : 20</p>

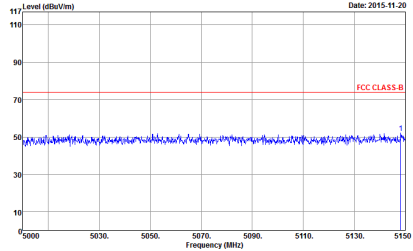
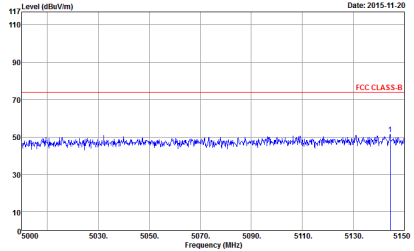
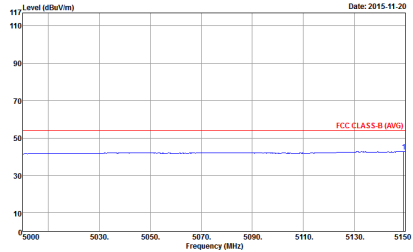
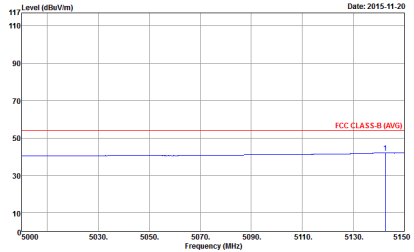

WIFI	Band 1 5150~5250MHz Band Edge @ 3m	
ANT	802.11a CH48 5240MHz - L	
2	Horizontal	Vertical
Peak	 <p>Site : 03CH10-HY Condition : FCC CLASS-B 3m HORN 9120D-HF HORIZONTAL Detector : Peak Project : 3N0602-02 Mode : Z1</p>	 <p>Site : 03CH10-HY Condition : FCC CLASS-B 3m HORN 9120D-HF VERTICAL Detector : Peak Project : 3N0602-02 Mode : Z1</p>
Avg.	 <p>Site : 03CH10-HY Condition : FCC CLASS-B (AVG) 3m HORN 9120D-HF HORIZONTAL Detector : Peak Project : 3N0602-02 Mode : Z1</p>	 <p>Site : 03CH10-HY Condition : FCC CLASS-B (AVG) 3m HORN 9120D-HF VERTICAL Detector : Peak Project : 3N0602-02 Mode : Z1</p>

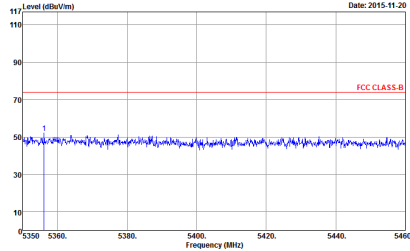
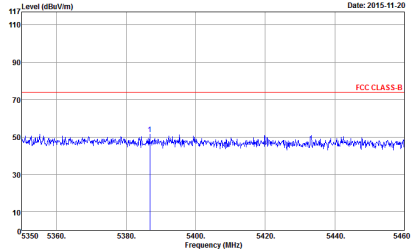
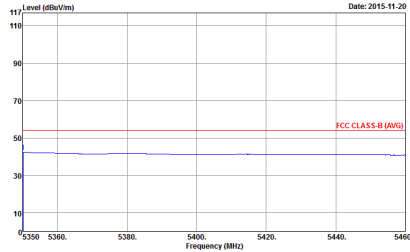
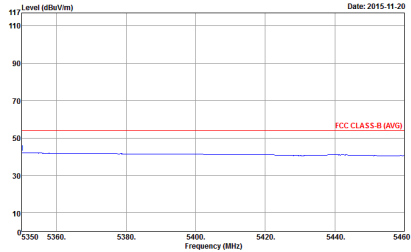

WIFI	Band 1 5150~5250MHz Band Edge @ 3m	
ANT	802.11a CH48 5240MHz - R	
2	Horizontal	Vertical
Peak	 <p>Date: 2015-11-20</p> <p>Level (dBuV/m)</p> <p>Frequency (MHz)</p> <p>FCC CLASS-B</p> <p>Site : 03CH10-HY Condition : FCC CLASS-B 3m HORN 9120D-HF HORIZONTAL RBW:1000.000KHz VBW:3000.000KHz SWT:Auto Detector : Peak Project : 3N0602-02 Mode : Z1</p>	 <p>Date: 2015-11-20</p> <p>Level (dBuV/m)</p> <p>Frequency (MHz)</p> <p>FCC CLASS-B</p> <p>Site : 03CH10-HY Condition : FCC CLASS-B 3m HORN 9120D-HF VERTICAL RBW:1000.000KHz VBW:3000.000KHz SWT:Auto Detector : Peak Project : 3N0602-02 Mode : Z1</p>
Avg.	 <p>Date: 2015-11-20</p> <p>Level (dBuV/m)</p> <p>Frequency (MHz)</p> <p>FCC CLASS-B (AVG)</p> <p>Site : 03CH10-HY Condition : FCC CLASS-B (AVG) 3m HORN 9120D-HF HORIZONTAL RBW:1000.000KHz VBW:0.010KHz SWT:Auto Detector : Peak Project : 3N0602-02 Mode : Z1</p>	 <p>Date: 2015-11-20</p> <p>Level (dBuV/m)</p> <p>Frequency (MHz)</p> <p>FCC CLASS-B (AVG)</p> <p>Site : 03CH10-HY Condition : FCC CLASS-B (AVG) 3m HORN 9120D-HF VERTICAL RBW:1000.000KHz VBW:0.010KHz SWT:Auto Detector : Peak Project : 3N0602-02 Mode : Z1</p>

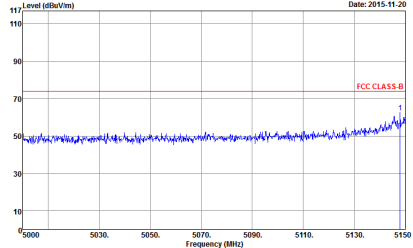
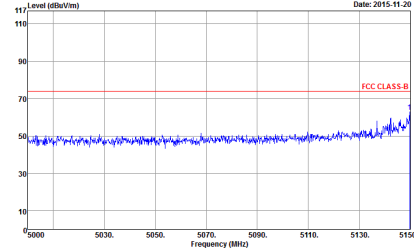
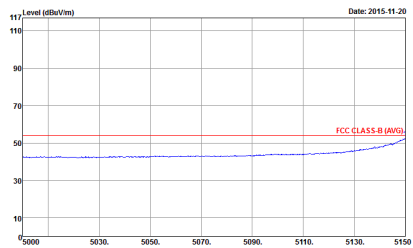
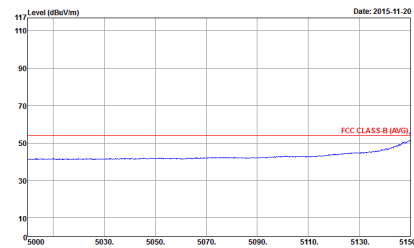

Band 1 5150~5250MHz
WIFI 802.11n HT20 (Band Edge @ 3m)

WIFI	Band 1 5150~5250MHz Band Edge @ 3m	
ANT	802.11n HT20 CH36 5180MHz	
2	Horizontal	Vertical
Peak	 <p>Site : 03CH10-HY Condition : FCC CLASS-B 3m HORN 9120D-HF HORIZONTAL RBW:1000.000KHz VBW:3000.000KHz SWT:Auto Detector : Peak Project : 3N0602-02 Mode : 22</p>	 <p>Site : 03CH10-HY Condition : FCC CLASS-B 3m HORN 9120D-HF VERTICAL RBW:1000.000KHz VBW:3000.000KHz SWT:Auto Detector : Peak Project : 3N0602-02 Mode : 22</p>
Avg.	 <p>Site : 03CH10-HY Condition : FCC CLASS-B (AVG) 3m HORN 9120D-HF HORIZONTAL RBW:1000.000KHz VBW:1.000KHz SWT:Auto Detector : Peak Project : 3N0602-02 Mode : 22</p>	 <p>Site : 03CH10-HY Condition : FCC CLASS-B (AVG) 3m HORN 9120D-HF VERTICAL RBW:1000.000KHz VBW:1.000KHz SWT:Auto Detector : Peak Project : 3N0602-02 Mode : 22</p>

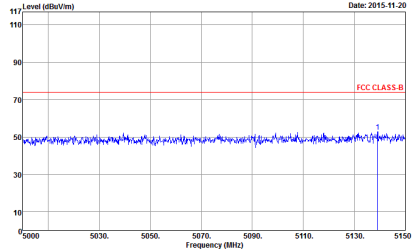
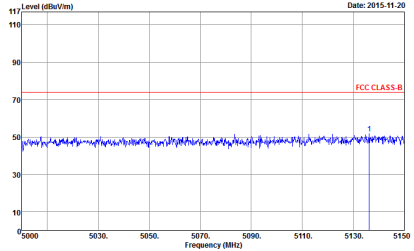
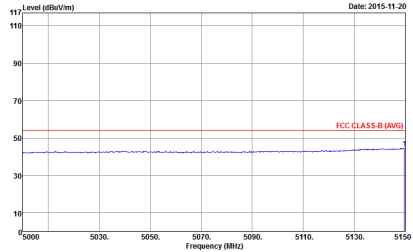
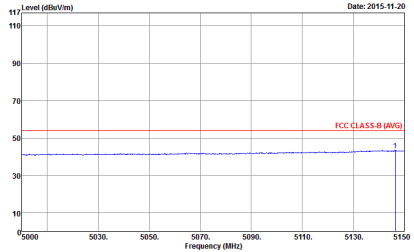

WIFI	Band 1 5150~5250MHz Band Edge @ 3m	
ANT	802.11n HT20 CH44 5220MHz - L	
2	Horizontal	Vertical
Peak	 <p>Date: 2015-11-20</p> <p>Level (dBuV/m)</p> <p>Frequency (MHz)</p> <p>FCC CLASS-B</p> <p>Site : 03CH10-HY Condition : FCC CLASS-B 3m HORN 9120D-HF HORIZONTAL RBW:1000.000KHz VBW:3000.000KHz SWT:Auto Detector : Peak Project : 3N0602-02 Mode : 23</p>	 <p>Date: 2015-11-20</p> <p>Level (dBuV/m)</p> <p>Frequency (MHz)</p> <p>FCC CLASS-B</p> <p>Site : 03CH10-HY Condition : FCC CLASS-B 3m HORN 9120D-HF VERTICAL RBW:1000.000KHz VBW:3000.000KHz SWT:Auto Detector : Peak Project : 3N0602-02 Mode : 23</p>
Avg.	 <p>Date: 2015-11-20</p> <p>Level (dBuV/m)</p> <p>Frequency (MHz)</p> <p>FCC CLASS-B (AVG)</p> <p>Site : 03CH10-HY Condition : FCC CLASS-B (AVG) 3m HORN 9120D-HF HORIZONTAL RBW:1000.000KHz VBW:1000KHz SWT:Auto Detector : Peak Project : 3N0602-02 Mode : 23</p>	 <p>Date: 2015-11-20</p> <p>Level (dBuV/m)</p> <p>Frequency (MHz)</p> <p>FCC CLASS-B (AVG)</p> <p>Site : 03CH10-HY Condition : FCC CLASS-B (AVG) 3m HORN 9120D-HF VERTICAL RBW:1000.000KHz VBW:1000KHz SWT:Auto Detector : Peak Project : 3N0602-02 Mode : 23</p>

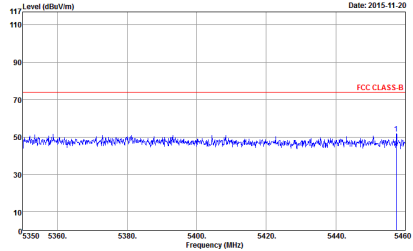
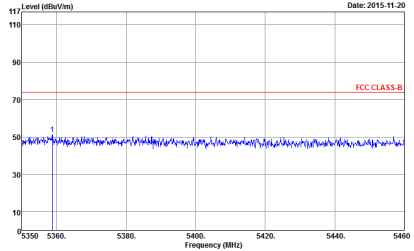
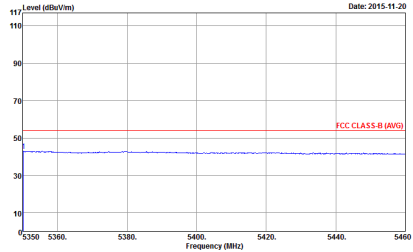
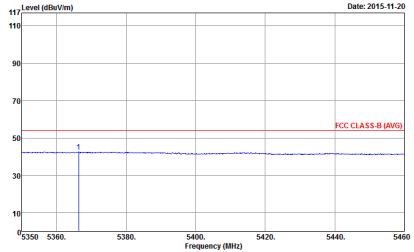

WIFI	Band 1 5150~5250MHz Band Edge @ 3m	
ANT	802.11n HT20 CH44 5220MHz - R	
2	Horizontal	Vertical
Peak	 <p>Level (dBuV/m) vs Frequency (MHz) plot for Horizontal orientation. The y-axis ranges from 10 to 117 dBuV/m, and the x-axis ranges from 5350 to 5460 MHz. A red horizontal line indicates the FCC CLASS-B limit at approximately 75 dBuV/m. The blue signal trace shows a peak at 5460 MHz reaching approximately 55 dBuV/m.</p> <p>Site : 03CH10-HY Condition : FCC CLASS-B 3m HORN 9120D-HF HORIZONTAL RBW:1000.000KHz VBW:3000.000KHz SWT:Auto Detector : Peak Project : 3N0602-02 Mode : 23</p>	 <p>Level (dBuV/m) vs Frequency (MHz) plot for Vertical orientation. The y-axis ranges from 10 to 117 dBuV/m, and the x-axis ranges from 5350 to 5460 MHz. A red horizontal line indicates the FCC CLASS-B limit at approximately 75 dBuV/m. The blue signal trace shows a peak at 5460 MHz reaching approximately 55 dBuV/m.</p> <p>Site : 03CH10-HY Condition : FCC CLASS-B 3m HORN 9120D-HF VERTICAL RBW:1000.000KHz VBW:3000.000KHz SWT:Auto Detector : Peak Project : 3N0602-02 Mode : 23</p>
Avg.	 <p>Level (dBuV/m) vs Frequency (MHz) plot for Horizontal orientation showing average values. The y-axis ranges from 10 to 117 dBuV/m, and the x-axis ranges from 5350 to 5460 MHz. A red horizontal line indicates the FCC CLASS-B (AVG) limit at approximately 55 dBuV/m. The blue signal trace is flat around 45 dBuV/m.</p> <p>Site : 03CH10-HY Condition : FCC CLASS-B (AVG) 3m HORN 9120D-HF HORIZONTAL RBW:1000.000KHz VBW:1000KHz SWT:Auto Detector : Peak Project : 3N0602-02 Mode : 23</p>	 <p>Level (dBuV/m) vs Frequency (MHz) plot for Vertical orientation showing average values. The y-axis ranges from 10 to 117 dBuV/m, and the x-axis ranges from 5350 to 5460 MHz. A red horizontal line indicates the FCC CLASS-B (AVG) limit at approximately 55 dBuV/m. The blue signal trace is flat around 45 dBuV/m.</p> <p>Site : 03CH10-HY Condition : FCC CLASS-B (AVG) 3m HORN 9120D-HF VERTICAL RBW:1000.000KHz VBW:1000KHz SWT:Auto Detector : Peak Project : 3N0602-02 Mode : 23</p>

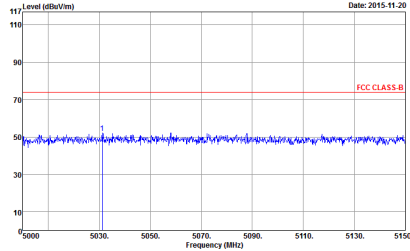
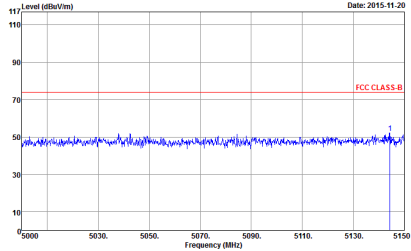
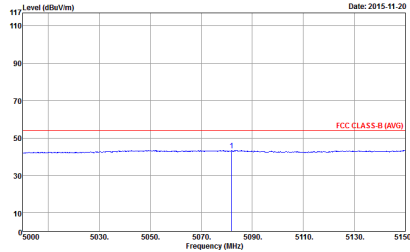
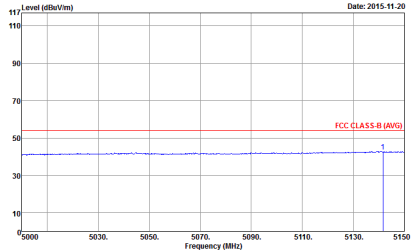

WIFI	Band 1 5150~5250MHz Band Edge @ 3m	
ANT	802.11n HT20 CH48 5240MHz - L	
2	Horizontal	Vertical
Peak	 <p>Date: 2015-11-20</p> <p>Level (dBuV/m)</p> <p>Frequency (MHz)</p> <p>FCC CLASS-B</p> <p>Site : 03CH10-HY Condition : FCC CLASS-B 3m HORN 9120D-HF HORIZONTAL RBW:1000.000KHz VBW:3000.000KHz SWT:Auto Detector : Peak Project : 3N0602-02 Mode : 24</p>	 <p>Date: 2015-11-20</p> <p>Level (dBuV/m)</p> <p>Frequency (MHz)</p> <p>FCC CLASS-B</p> <p>Site : 03CH10-HY Condition : FCC CLASS-B 3m HORN 9120D-HF VERTICAL RBW:1000.000KHz VBW:3000.000KHz SWT:Auto Detector : Peak Project : 3N0602-02 Mode : 24</p>
Avg.	 <p>Date: 2015-11-20</p> <p>Level (dBuV/m)</p> <p>Frequency (MHz)</p> <p>FCC CLASS-B (AVG)</p> <p>Site : 03CH10-HY Condition : FCC CLASS-B (AVG) 3m HORN 9120D-HF HORIZONTAL RBW:1000.000KHz VBW:1000KHz SWT:Auto Detector : Peak Project : 3N0602-02 Mode : 24</p>	 <p>Date: 2015-11-20</p> <p>Level (dBuV/m)</p> <p>Frequency (MHz)</p> <p>FCC CLASS-B (AVG)</p> <p>Site : 03CH10-HY Condition : FCC CLASS-B (AVG) 3m HORN 9120D-HF VERTICAL RBW:1000.000KHz VBW:1000KHz SWT:Auto Detector : Peak Project : 3N0602-02 Mode : 24</p>

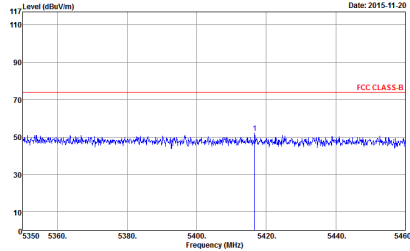
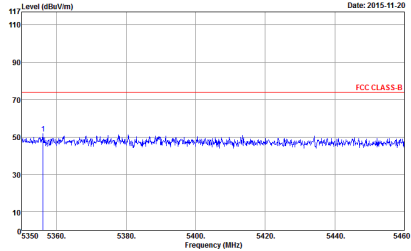
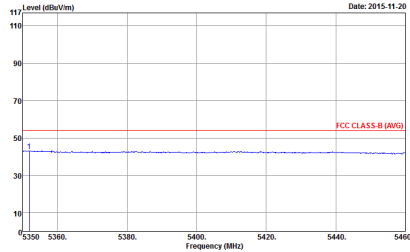
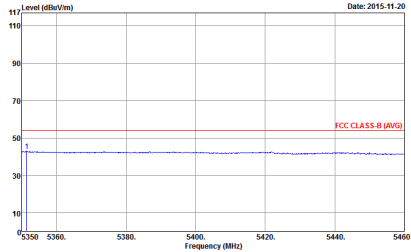

WIFI	Band 1 5150~5250MHz Band Edge @ 3m	
ANT	802.11n HT20 CH48 5240MHz - R	
2	Horizontal	Vertical
Peak	 <p>Date: 2015-11-20</p> <p>Level (dBuV/m)</p> <p>Frequency (MHz)</p> <p>FCC CLASS-B</p> <p>Site : 03CH10-HY Condition : FCC CLASS-B 3m HORN 9120D-HF HORIZONTAL RBW:1000.000KHz VBW:3000.000KHz SWT:Auto Detector : Peak Project : 3N0602-02 Mode : 24</p>	 <p>Date: 2015-11-20</p> <p>Level (dBuV/m)</p> <p>Frequency (MHz)</p> <p>FCC CLASS-B</p> <p>Site : 03CH10-HY Condition : FCC CLASS-B 3m HORN 9120D-HF VERTICAL RBW:1000.000KHz VBW:3000.000KHz SWT:Auto Detector : Peak Project : 3N0602-02 Mode : 24</p>
Avg.	 <p>Date: 2015-11-20</p> <p>Level (dBuV/m)</p> <p>Frequency (MHz)</p> <p>FCC CLASS-B (AVG)</p> <p>Site : 03CH10-HY Condition : FCC CLASS-B (AVG) 3m HORN 9120D-HF HORIZONTAL RBW:1000.000KHz VBW:1000KHz SWT:Auto Detector : Peak Project : 3N0602-02 Mode : 24</p>	 <p>Date: 2015-11-20</p> <p>Level (dBuV/m)</p> <p>Frequency (MHz)</p> <p>FCC CLASS-B (AVG)</p> <p>Site : 03CH10-HY Condition : FCC CLASS-B (AVG) 3m HORN 9120D-HF VERTICAL RBW:1000.000KHz VBW:1000KHz SWT:Auto Detector : Peak Project : 3N0602-02 Mode : 24</p>



Band 1 - 5150~5250MHz

WIFI 802.11a (Harmonic @ 3m)

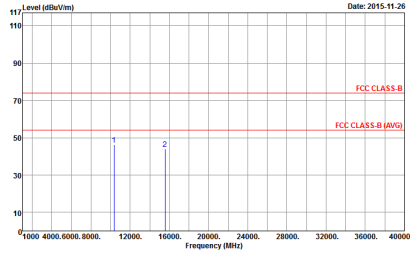
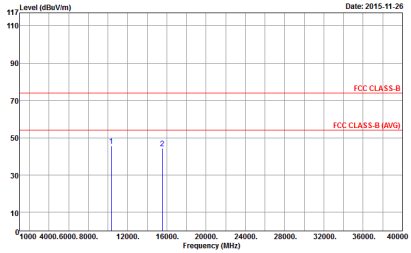
WIFI	Band 1 5150~5250MHz Harmonic @ 3m	
ANT	802.11a CH36 5180MHz	
2	Horizontal	Vertical
Peak Avg.	 <p>Site : 03CH10-HY Condition : FCC CLASS-B 3m HORN 9120D-HF HORIZONTAL Detector : Peak Project : 3N0602-02 Mode : 19</p>	 <p>Site : 03CH10-HY Condition : FCC CLASS-B 3m HORN 9120D-HF VERTICAL Detector : Peak Project : 3N0602-02 Mode : 19</p>

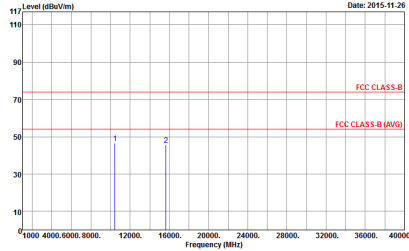
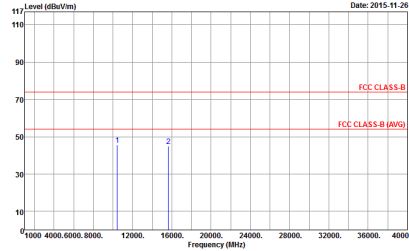

WIFI	Band 1 5150~5250MHz Harmonic @ 3m	
ANT	802.11a CH44 5220MHz	
2	Horizontal	Vertical
<p>Peak</p> <p>Avg.</p>	 <p>Site : 00CH10-HV Condition : FCC CLASS-B 3m HORN 9120D-HF HORIZONTAL Detector : Peak Project : 3N0602-02 Mode : 20</p>	 <p>Site : 00CH10-HV Condition : FCC CLASS-B 3m HORN 9120D-HF VERTICAL Detector : Peak Project : 3N0602-02 Mode : 20</p>



WIFI	Band 1 5150~5250MHz Harmonic @ 3m	
ANT	802.11a CH48 5240MHz	
2	Horizontal	Vertical
Peak Avg.	<p>Site : 00CH10-HY Condition : FCC CLASS-B 3m HORN 9120D-HF HORIZONTAL Detector : Peak Project : 3N0602-02 Mode : Z1</p>	<p>Site : 00CH10-HY Condition : FCC CLASS-B 3m HORN 9120D-HF VERTICAL Detector : Peak Project : 3N0602-02 Mode : Z1</p>

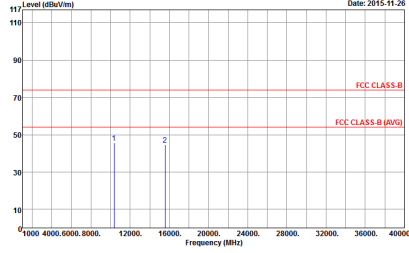
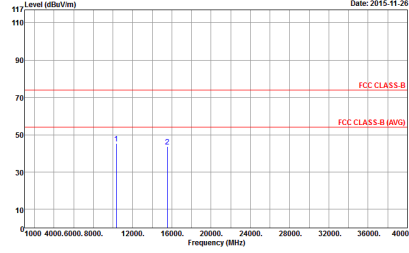

**Band 1 5150~5250MHz
WIFI 802.11n HT20 (Harmonic @ 3m)**

WIFI	Band 1 5150~5250MHz Harmonic @ 3m	
ANT	802.11n HT20 CH36 5180MHz	
2	Horizontal	Vertical
<p>Peak</p> <p>Avg.</p>	 <p>Date: 2015-11-26</p> <p>Site : 03CH10-HY Condition : FCC CLASS-B 3m HORN 9120D-HF HORIZONTAL Detector : Peak Project : 3N0602-02 Mode : 22</p>	 <p>Date: 2015-11-26</p> <p>Site : 03CH10-HY Condition : FCC CLASS-B 3m HORN 9120D-HF VERTICAL Detector : Peak Project : 3N0602-02 Mode : 22</p>

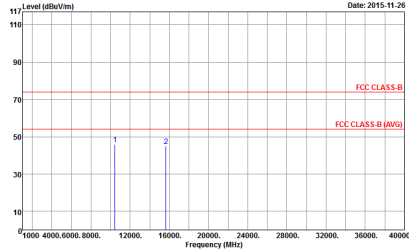
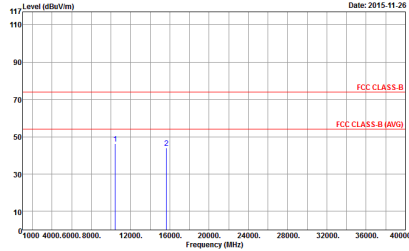

WIFI	Band 1 5150~5250MHz Harmonic @ 3m	
ANT	802.11n HT20 CH44 5220MHz	
2	Horizontal	Vertical
<p>Peak</p> <p>Avg.</p>	 <p>Site : 00CH10-HY Condition : FCC CLASS-B 3m HORN 9120D-HF HORIZONTAL Detector : Peak Project : 3N0602-02 Mode : Z3</p>	 <p>Site : 00CH10-HY Condition : FCC CLASS-B 3m HORN 9120D-HF VERTICAL Detector : Peak Project : 3N0602-02 Mode : Z3</p>

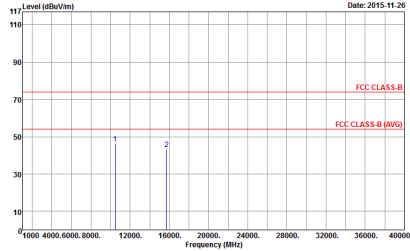
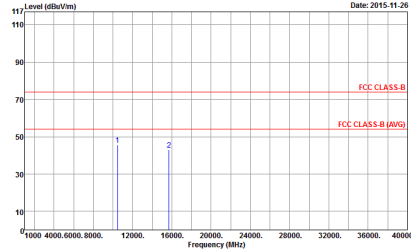

WIFI	Band 1 5150~5250MHz Harmonic @ 3m	
ANT	802.11n HT20 CH48 5240MHz	
2	Horizontal	Vertical
<p>Peak</p> <p>Avg.</p>	 <p style="font-size: small;">Date: 2015-11-26</p> <p style="font-size: x-small;">Site : 00CH10-HY Condition : FCC CLASS-B 3m HORN 9120D-HF HORIZONTAL Detector : Peak Project : 3N0602-02 Mode : 24</p>	 <p style="font-size: small;">Date: 2015-11-26</p> <p style="font-size: x-small;">Site : 00CH10-HY Condition : FCC CLASS-B 3m HORN 9120D-HF VERTICAL Detector : Peak Project : 3N0602-02 Mode : 24</p>



Emission below 1GHz

5GHz WIFI 802.11n HT20 (LF)

WIFI	5GHz WIFI	
ANT	802.11n HT20 LF	
2	Horizontal	Vertical
QP / Peak	<p> Site : 03CH10-HY Condition : FCC CLASS-B 3m BT-LOG 6111D-LF HORIZONTAL Detector : Peak Project : 3N0602-02 Mode : 28 </p>	<p> Site : 03CH10-HY Condition : FCC CLASS-B 3m BT-LOG 6111D-LF VERTICAL Detector : Peak Project : 3N0602-02 Mode : 28 </p>