



A D T

Supplemental “Transmit Simultaneously” Test Report

REPORT NO.: IC111028C08A-4

MODEL NO.: 21-148603-0B

IC: 109AN-211486030B

RECEIVED: Oct. 28, 2011

TESTED: Nov. 25 to 30, 2011

ISSUED: Mar. 09, 2012

APPLICANT: Motorola Solutions, Inc.

ADDRESS: 1 Motorola Plaza, Holtsville, NY 11742-1300 USA

ISSUED BY: Bureau Veritas Consumer Products Services
(H.K.) Ltd., Taoyuan Branch Hsin Chu Laboratory

LAB ADDRESS : No. 81-1, Lu Liao Keng, 9th Ling,Wu Lung Tsuen,
Chiung Lin Hsiang, Hsin Chu Hsien 307, Taiwan

TEST LOCATION (1): No. 81-1, Lu Liao Keng, 9th Ling,Wu Lung Tsuen,
Chiung Lin Hsiang, Hsin Chu Hsien 307, Taiwan

TEST LOCATION (2): No. 49, Ln. 206, Wende Rd., Shangshan Tsuen,
Chiung Lin Hsiang, Hsin Chu Hsien 307, Taiwan

This test report consists of 23 pages in total. It may be duplicated completely for legal use with the approval of the applicant. It should not be reproduced except in full, without the written approval of our laboratory. The client should not use it to claim product certification, approval, or endorsement by TAF or any government agencies. The test results in the report only apply to the tested sample.





Table of Contents

RELEASE CONTROL RECORD	3
1. CERTIFICATION	4
2. SUMMARY OF TEST RESULTS.....	5
2.1 MEASUREMENT UNCERTAINTY	5
3. GENERAL INFORMATION	6
3.1 GENERAL DESCRIPTION OF EUT	6
3.2 TEST MODE APPLICABILITY AND TESTED CHANNEL DETAIL:.....	8
3.3 DESCRIPTION OF SUPPORT UNITS	9
3.4 CONFIGURATION OF SYSTEM UNDER TEST.....	10
4. TEST TYPES AND RESULTS.....	11
4.1 CONDUCTED EMISSION MEASUREMENT.....	11
4.1.1 LIMITS OF CONDUCTED EMISSION MEASUREMENT.....	11
4.1.2 TEST INSTRUMENTS.....	11
4.1.3 TEST PROCEDURES	12
4.1.4 DEVIATION FROM TEST STANDARD.....	12
4.1.5 TEST SETUP	13
4.1.6 EUT OPERATING CONDITIONS.....	13
4.1.7 TEST RESULTS	14
4.2 RADIATED EMISSION MEASUREMENT.....	16
4.2.1 LIMITS OF RADIATED EMISSION MEASUREMENT.....	16
4.2.2 TEST INSTRUMENTS.....	17
4.2.3 TEST PROCEDURES	19
4.2.4 DEVIATION FROM TEST STANDARD.....	19
4.2.5 TEST SETUP	20
4.2.6 EUT OPERATING CONDITIONS.....	20
4.2.7 TEST RESULTS	21
4. INFORMATION ON THE TESTING LABORATORIES.....	23



A D T

RELEASE CONTROL RECORD

ISSUE NO.	REASON FOR CHANGE	DATE ISSUED
IC111028C08A-4	Original release	Mar. 09, 2012



A D T

1. CERTIFICATION

PRODUCT : Radio Module
BRAND NAME : Motorola
MODEL NO. : 21-148603-0B
TEST ITEM: ENGINEERING SAMPLE
APPLICANT : Motorola Solutions, Inc.
TESTED: Nov. 25 to 30, 2011
STANDARDS: Canada RSS-210 Issue 8 (2010-12)
Canada RSS-Gen Issue 3 (2010-12)
ANSI C63.4-2003
ANSI C63.10-2009

The above equipment (Model: 21-148603-0B) has been tested by **Bureau Veritas Consumer Products Services (H.K.) Ltd., Taoyuan Branch**, and found compliance with the requirement of the above standards. The test record, data evaluation & Equipment Under Test (EUT) configurations represented herein are true and accurate accounts of the measurements of the sample's EMC characteristics under the conditions specified in this report.

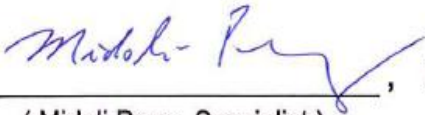
PREPARED BY : , **DATE:** Mar. 09, 2012
(Midoli Peng, Specialist)

APPROVED BY : , **DATE:** Mar. 09, 2012
(May Chen, Deputy Manager)



2. SUMMARY OF TEST RESULTS

The EUT has been tested according to the following specifications:

APPLIED STANDARD: RSS-210; RSS-Gen			
Standard Section	Test Type and Limit	Result	Remark
RSS-Gen			
7.2.4	AC Power Conducted Emission	PASS	Meet the requirement of limit. Minimum passing margin is -17.79dB at 7.168MHz
Standard Section	Test Type and Limit	Result	Remark
RSS-210			
A8.5	Transmitter Radiated Emissions RSS-Gen Limit: Table 5, 6	PASS	Meet the requirement of limit. Minimum passing margin is -4.6dB at 40.78MHz

2.1 MEASUREMENT UNCERTAINTY

Where relevant, the following measurement uncertainty levels have been estimated for tests performed on the EUT as specified in CISPR 16-4-2:

This uncertainty represents an expanded uncertainty expressed at approximately the 95% confidence level using a coverage factor of k=2.

Measurement	Value
Conducted emissions	2.45 dB
Radiated emissions (30MHz-1GHz)	3.89 dB
Radiated emissions (1GHz -18GHz)	2.19 dB
Radiated emissions (18GHz -40GHz)	2.56 dB



3. GENERAL INFORMATION

3.1 GENERAL DESCRIPTION OF EUT

PRODUCT	Radio Module
MODEL NO.	21-148603-0B
IC	109AN-211486030B
POWER SUPPLY	DC 3.3V
MODULATION TYPE	CCK, DQPSK, DBPSK for DSSS 64QAM, 16QAM, QPSK, BPSK for OFDM
MODULATION TECHNOLOGY	DSSS, OFDM
TRANSFER RATE	802.11b: up to 11Mbps 802.11g: up to 54Mbps 802.11n (20MHz, 800ns GI): up to 72.2Mbps 802.11n (20MHz, 400ns GI): up to 65Mbps
OPERATING FREQUENCY	For Annex 9 802.11a: 5.18 ~ 5.24GHz, 5.26 ~ 5.32GHz, 5.5~5.58GHz & 5.66~5.7GHz
	For Annex 8 802.11b & 802.11g: 2.412 ~ 2.472GHz 802.11a: 5.745 ~ 5.825GHz
NUMBER OF CHANNEL	For Annex 9 16 for 802.11a, 802.11n (20MHz)
	For Annex 8(2.4GHz) 13 for 802.11b, 802.11g, 802.11n (20MHz)
	For Annex 8(5GHz) 5 for 802.11a, 802.11n (20MHz)
MAXIMUM OUTPUT POWER	For Annex 9 802.11a: 102.3mW 802.11n (20MHz): 89.1mW
	For Annex 8(2.4GHz) 802.11b: 208.9mW 802.11g: 257.0mW 802.11n (20MHz): 251.2mW
	For Annex 8(5GHz) 802.11a: 158.5mW 802.11n (20MHz): 154.9mW
ANTENNA TYPE	Please see note



DATA CABLE	NA
I/O PORTS	NA
ASSOCIATED DEVICES	NA

NOTE:

1. There are Bluetooth technology, GPS technology and WLAN technology used for the EUT and the functions of EUT listed as below table:

Function	Report No.
WLAN	IC111028C08A (Annex 8) IC111028C08A-1(Annex 9)
Bluetooth	IC111028C08A-2
GPS	IC111028C08A-3

2. The antennas provided to the EUT, please refer to the following table:

No.	Type	Connector	Model	Peak Gain (dBi)	Cable loss (dB)	Net Peak Gain (dBi)	Trace
1	Dipole-1	Reverse SMA	ML-2452-APA2-01 Rev C	2.4GHz : 3 5GHz : 5	2.4GHz : 0.75 5GHz : 1.3	2.4GHz : 2.25 5GHz : 3.7	WiFi
2	Dipole-2	Reverse SMA	C492-510032-A	1.8	2.35	-0.55	BT
3	Chip	Reverse SMA	NA	-	-		GPS

3. The EUT was included two SKU, which are identical to each other in all aspects except for the following table:

	P/N	Description
SKU #1	21-148603-02	Diversity version with WLAN and BT on SEPARATE RF paths
SKU #2	21-148603-04	NON-Diversity version with WLAN and BT on SEPARATE RF paths

SKU #1, the worse case one, was chosen for final test.

4. The device can transmit simultaneously on WLAN (5GHz) mode and Bluetooth mode; other modes can't support simultaneously ability. This report was recorded the device transmit simultaneously test data.
5. The EUT is 1 * 1 spatial SISO (1Tx & 1Rx) without beam forming function.
6. The above EUT information was declared by the manufacturer and for more detailed features description, please refer to the manufacturer's specifications or User's manual.



3.2 TEST MODE APPLICABILITY AND TESTED CHANNEL DETAIL:

EUT configure mode	Applicable to			Description
	PLC	RE<1G	RE [≥] 1G	
-	√	√	√	

Where PLC: Power Line Conducted Emission RE<1G RE: Radiated Emission below 1GHz
 RE≥1G: Radiated Emission above 1GHz

Note1: Pre-Scan has been conducted to determine the worst case mode from antenna power.

POWER LINE CONDUCTED EMISSION TEST:

- Pre-Scan has been conducted to determine the worst-case mode from all possible combinations between available modulations, data rates and antenna ports (if EUT with antenna diversity architecture).
- Following channel(s) was (were) selected for the final test as listed below.

Mode	Available Channel	Tested Channel	Modulation Technology	Modulation Type	Data Rate (Mbps)
5 GHz 802.11a + Bluetooth	149 to 165	157	OFDM	BPSK	6
	0 to 78	0	FHSS	8DPSK	-

RADIATED EMISSION TEST:

- Pre-Scan has been conducted to determine the worst-case mode from all possible combinations between available modulations, data rates and antenna ports (if EUT with antenna diversity architecture).
- Following channel(s) was (were) selected for the final test as listed below.

Mode	Available Channel	Tested Channel	Modulation Technology	Modulation Type	Data Rate (Mbps)
5 GHz 802.11a + Bluetooth	149 to 165	157	OFDM	BPSK	6
	0 to 78	0	FHSS	8DPSK	-

TEST CONDITION:

APPLICABLE TO	ENVIRONMENTAL CONDITIONS	INPUT POWER	TESTED BY
PLC	26deg. C, 68%RH	120Vac, 60Hz(system)	Andy Ho
RE<1G	18deg. C, 64%RH	DC 3.3V	Nick Chang
RE [≥] 1G	19deg. C, 66%RH	DC 3.3V	Kent Liu



3.3 DESCRIPTION OF SUPPORT UNITS

The EUT has been tested as an independent unit together with other necessary accessories or support units. The following support units or accessories were used to form a representative test configuration during the tests.

No.	Product	Brand	Model No.	Serial No.	FCC ID
1	NOTEBOOK COMPUTER	DELL	PP32LA	FSLB32S	FCC DoC
2	DC POWER SUPPLY	Topward	6603D	795558	NA

No.	Signal cable description
1	USB cable (1.8m with one core)
2	DC line (2m)

Note: 1. All power cords of the above support units are unshielded (1.8m).

3.4 CONFIGURATION OF SYSTEM UNDER TEST

For Conducted emission test:

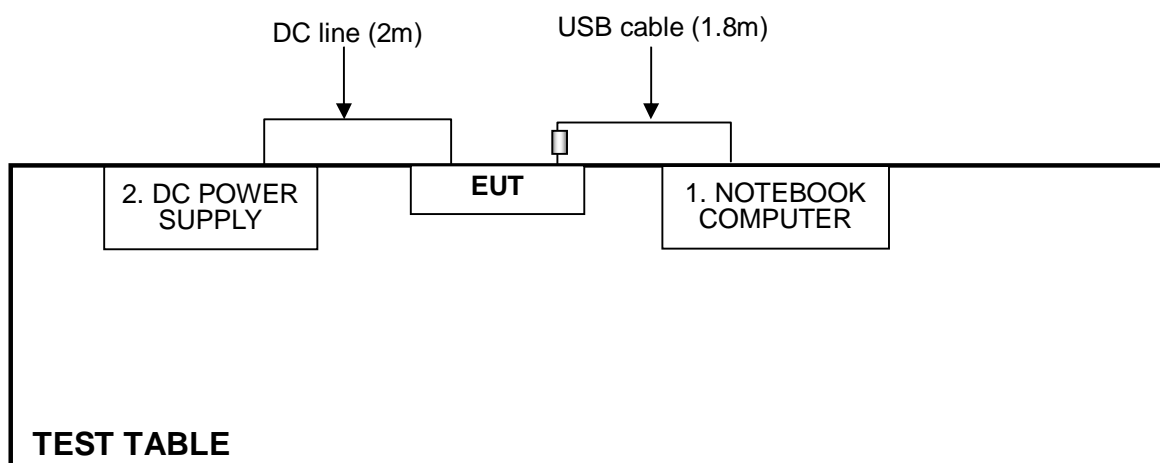

For other test items:

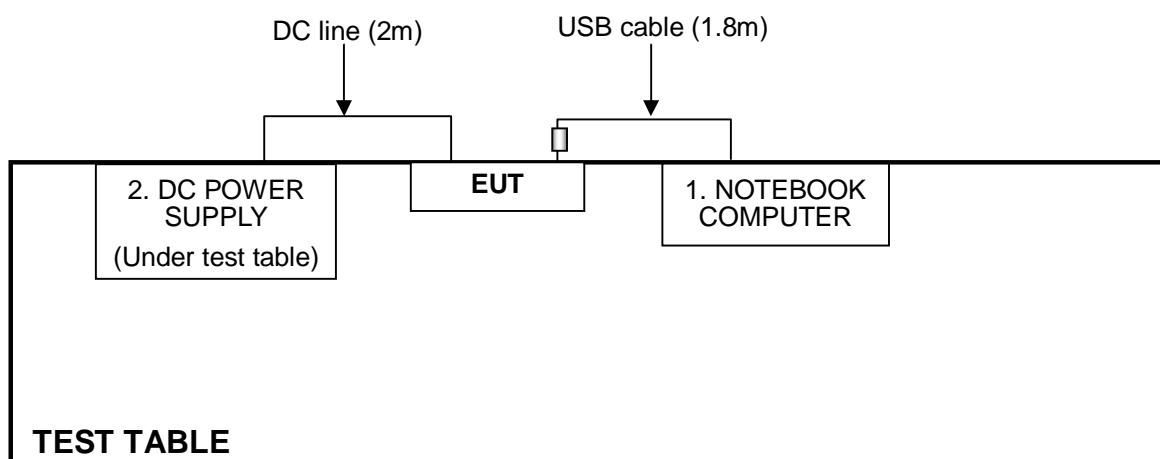



4. TEST TYPES AND RESULTS

4.1 CONDUCTED EMISSION MEASUREMENT

4.1.1 LIMITS OF CONDUCTED EMISSION MEASUREMENT

FREQUENCY OF EMISSION (MHz)	CONDUCTED LIMIT (dBµV)	
	Quasi-peak	Average
0.15-0.5	66 to 56	56 to 46
0.5-5	56	46
5-30	60	50

- NOTE:**
1. The lower limit shall apply at the transition frequencies.
 2. The limit decreases in line with the logarithm of the frequency in the range of 0.15 to 0.50 MHz.
 3. All emanations from a class A/B digital device or system, including any network of conductors and apparatus connected thereto, shall not exceed the level of field strengths specified above.

4.1.2 TEST INSTRUMENTS

Test date: Nov. 25, 2011

DESCRIPTION & MANUFACTURER	MODEL NO.	SERIAL NO.	CALIBRATED DATE	CALIBRATED UNTIL
Test Receiver	ESCS 30	100375	Mar. 09, 2011	Mar. 08, 2012
Line-Impedance Stabilization Network (for EUT)	NSLK8127	8127-522	Sep. 07, 2011	Sep. 06, 2012
Line-Impedance Stabilization Network (for Peripheral)	ESH3-Z5	848773/004	Nov. 01, 2011	Oct. 31, 2012
RF Cable (JYEBAO)	5DFB	COCCAB-002	Aug. 29, 2011	Aug. 28, 2012
50 ohms Terminator	50	3	Nov. 02, 2011	Nov. 01, 2012
Software	BV ADT_Cond_V7.3.7	NA	NA	NA

Note:

1. The calibration interval of the above test instruments is 12 months and the calibrations are traceable to NML/ROC and NIST/USA.
2. The test was performed in Shielded Room No. C.
3. The VCCI Con C Registration No. is C-3611.



4.1.3 TEST PROCEDURES

- a. The EUT was placed 0.4 meters from the conducting wall of the shielded room with EUT being connected to the power mains through a line impedance stabilization network (LISN). Other support units were connected to the power mains through another LISN. The two LISNs provide 50 ohm/ 50uH of coupling impedance for the measuring instrument.
- b. Both lines of the power mains connected to the EUT were checked for maximum conducted interference.
- c. The frequency range from 150kHz to 30MHz was searched. Emission levels under (Limit - 20dB) were not recorded.

4.1.4 DEVIATION FROM TEST STANDARD

No deviation

4.1.5 TEST SETUP

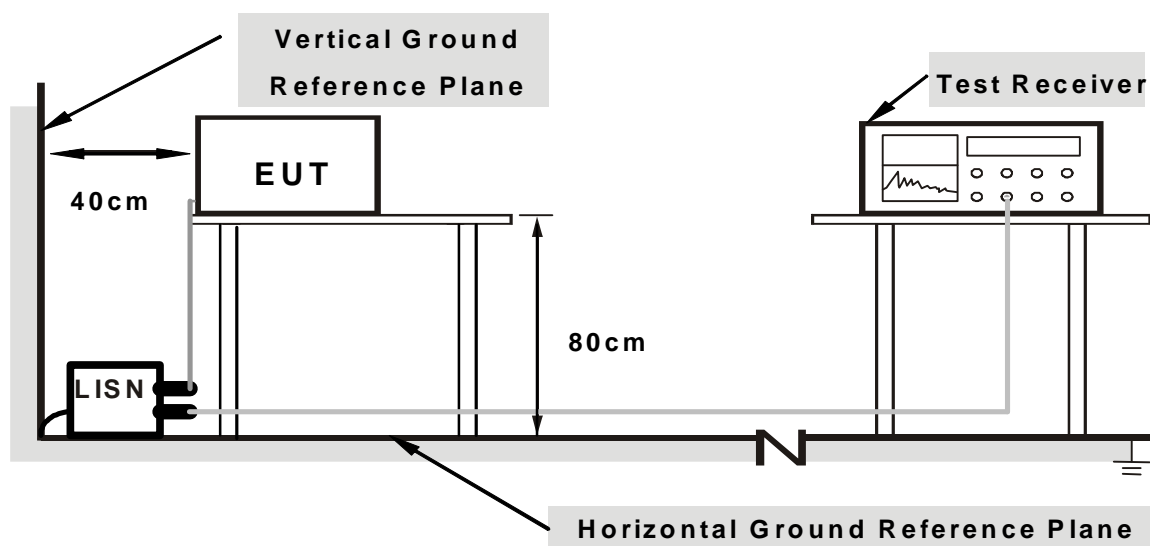

Note: 1. Support units were connected to second LISN.

2. Both of LISNs (AMN) are 80 cm from EUT and at least 80 from other units and other metal planes

For the actual test configuration, please refer to the related item – Photographs of the Test Configuration.

4.1.6 EUT OPERATING CONDITIONS

1. Connect the EUT with the support unit 1 (Notebook Computer) which is placed on a testing table.
2. The communication partner run test program “RTTT.exe” to enable EUT under transmission/receiving condition continuously at specific channel frequency.

4.1.7 TEST RESULTS

PHASE	Line (L)	6dB BANDWIDTH	9 kHz
--------------	----------	----------------------	-------

No	Freq.	Corr.	Reading Value		Emission Level		Limit		Margin	
	[MHz]	Factor (dB)	[dB (uV)]		[dB (uV)]		[dB (uV)]		(dB)	
			Q.P.	AV.	Q.P.	AV.	Q.P.	AV.	Q.P.	AV.
1	0.459	0.11	9.81	-5.24	9.92	-5.13	56.72	46.72	-46.79	-51.84
2	2.594	0.24	20.75	11.14	20.99	11.38	56.00	46.00	-35.01	-34.62
3	5.391	0.37	33.67	25.82	34.04	26.19	60.00	50.00	-25.96	-23.81
4	7.168	0.44	34.47	31.74	34.91	32.18	60.00	50.00	-25.09	-17.82
5	9.895	0.55	29.03	25.14	29.58	25.69	60.00	50.00	-30.42	-24.31
6	24.000	0.86	23.56	22.61	24.42	23.47	60.00	50.00	-35.58	-26.53

- REMARKS:**
1. Q.P. and AV. are abbreviations of quasi-peak and average individually.
 2. The emission levels of other frequencies were very low against the limit.
 3. Margin value = Emission level - Limit value
 4. Correction factor = Insertion loss + Cable loss
 5. Emission Level = Correction Factor + Reading Value.

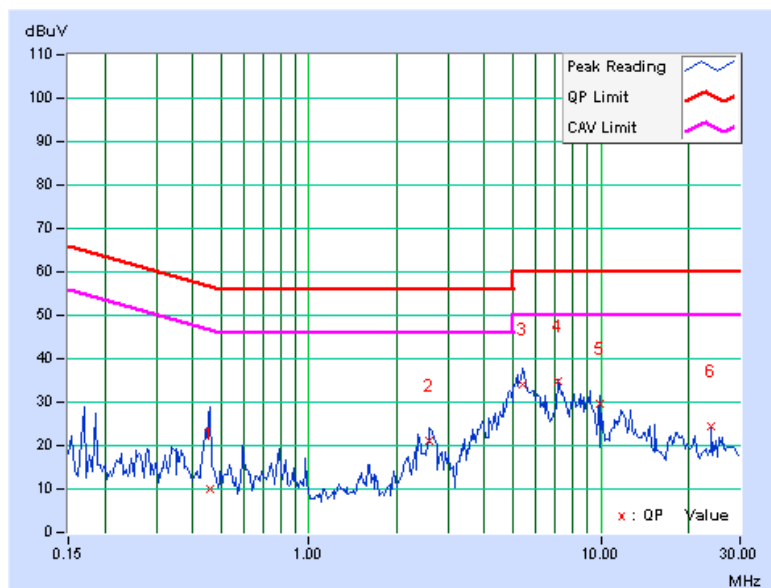



PHASE	Neutral (N)	6dB BANDWIDTH	9 kHz
--------------	-------------	----------------------	-------

No	Freq. [MHz]	Corr. Factor (dB)	Reading Value [dB (uV)]		Emission Level [dB (uV)]		Limit [dB (uV)]		Margin (dB)	
			Q.P.	AV.	Q.P.	AV.	Q.P.	AV.	Q.P.	AV.
			1	0.384	0.11	9.90	-6.32	10.01	-6.21	58.18
2	3.645	0.23	19.22	10.59	19.45	10.82	56.00	46.00	-36.55	-35.18
3	5.242	0.28	34.87	26.45	35.15	26.73	60.00	50.00	-24.85	-23.27
4	7.168	0.33	34.37	31.88	34.70	32.21	60.00	50.00	-25.30	-17.79
5	9.895	0.41	28.13	24.12	28.54	24.53	60.00	50.00	-31.46	-25.47
6	24.000	0.75	28.76	27.88	29.51	28.63	60.00	50.00	-30.49	-21.37

- REMARKS:**
1. Q.P. and AV. are abbreviations of quasi-peak and average individually.
 2. The emission levels of other frequencies were very low against the limit.
 3. Margin value = Emission level - Limit value
 4. Correction factor = Insertion loss + Cable loss
 5. Emission Level = Correction Factor + Reading Value.

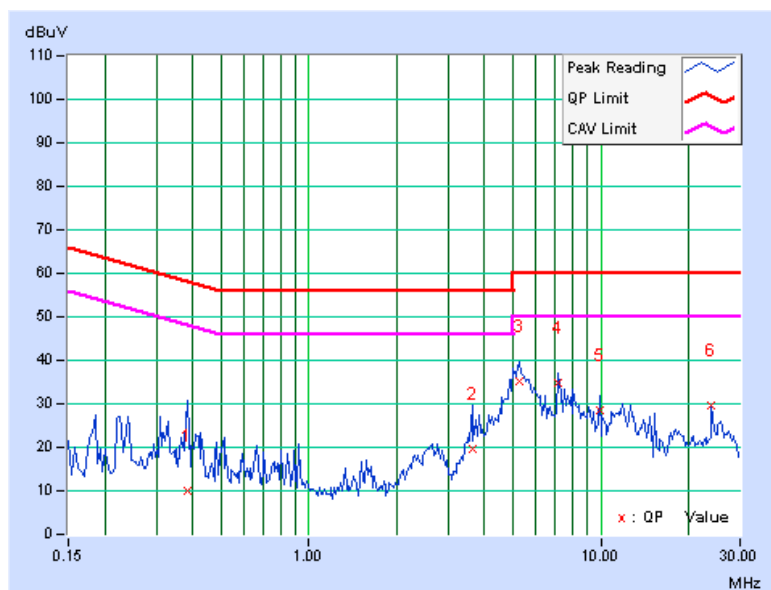



4.2 RADIATED EMISSION MEASUREMENT

4.2.1 LIMITS OF RADIATED EMISSION MEASUREMENT

Emissions radiated outside of the specified bands, shall be according to the general radiated limits in RSS-Gen table 5, 6 as following:

Frequencies (MHz)	Field strength (microvolts/meter)	Measurement distance (meters)
0.009-0.490	2400/F(kHz)	300
0.490-1.705	24000/F(kHz)	30
1.705-30.0	30	30
30-88	100	3
88-216	150	3
216-960	200	3
Above 960	500	3

NOTE:

1. The lower limit shall apply at the transition frequencies.
2. Emission level (dBuV/m) = 20 log Emission level (uV/m).
3. For frequencies above 1000MHz, the field strength limits are based on average detector, however, the peak field strength of any emission shall not exceed the maximum permitted average limits, specified above by more than 20dB.



A D T

4.2.2 TEST INSTRUMENTS

For below 1GHz: Test date: Nov. 26, 2011

DESCRIPTION & MANUFACTURER	MODEL NO.	SERIAL NO.	CALIBRATED DATE	CALIBRATED UNTIL
Agilent Spectrum Analyzer	E4446A	MY48250253	Aug. 29, 2011	Aug. 28, 2012
Agilent Pre-Selector	N9039A	MY46520310	Aug. 29, 2011	Aug. 28, 2012
Agilent Signal Generator	N5181A	MY49060347	July 25, 2011	July 24, 2012
Mini-Circuits Pre-Amplifier	ZFL-1000VH2B	AMP-ZFL-04	Nov. 15, 2011	Nov. 14, 2012
Agilent Pre-Amplifier	8449B	3008A02465	Feb. 28, 2011	Feb. 27, 2012
SPACEK LABS	SLKKa-48-6	9K16	Nov. 15, 2011	Nov. 14, 2012
SCHWARZBECK Trilog Broadband Antenna	VULB 9168	9168-361	Apr. 14, 2011	Apr. 13, 2012
AISI Horn_Antenna	AIH.8018	0000220091110	Nov. 22, 2011	Nov. 21, 2012
SCHWARZBECK Horn_Antenna	BBHA 9170	9170-424	Oct. 07, 2011	Oct. 06, 2012
RF CABLE	NA	RF104-205 RF104-207 RF104-202	Dec. 28, 2010	Dec. 27, 2011
RF Cable	NA	CHHCAB_001	Oct. 08, 2011	Oct. 07, 2012
Software	ADT_Radiated_V8.7.05	NA	NA	NA
CT Antenna Tower & Turn Table	NA	NA	NA	NA

Note: 1. The calibration interval of the above test instruments is 12 months and the calibrations are traceable to NML/ROC and NIST/USA.

2. The horn antenna, preamplifier (model: 8449B) are used only for the measurement of emission frequency above 1GHz if tested.

3. The test was performed in 966 Chamber No. H.

4. The FCC Site Registration No. is 797305.

5. The CANADA Site Registration No. is IC 7450H-3.



A D T

For above 1GHz: Test date: Nov. 30, 2011

DESCRIPTION & MANUFACTURER	MODEL NO.	SERIAL NO.	CALIBRATED DATE	CALIBRATED UNTIL
Agilent Spectrum Analyzer	E4446A	MY48250254	July 12, 2011	July 11, 2012
Agilent Pre-Selector	N9039A	MY46520311	July 12, 2011	July 11, 2012
Agilent Signal Generator	N5181A	MY49060517	July 12, 2011	July 11, 2012
Mini-Circuits Pre-Amplifier	ZFL-1000VH2B	AMP-ZFL-03	Nov. 15, 2011	Nov. 14, 2012
Agilent Pre-Amplifier	8449B	3008A02578	July 04, 2011	July 03, 2012
SPACEK LABS	SLKka-48-6	9K16	Nov. 15, 2011	Nov. 14, 2012
SCHWARZBECK Trilog Broadband Antenna	VULB 9168	9168-360	Apr. 14, 2011	Apr. 13, 2012
AISI Horn_Antenna	AIH.8018	0000320091110	Nov. 14, 2011	Nov. 13, 2012
SCHWARZBECK Horn_Antenna	BBHA 9170	9170-424	Oct. 07, 2011	Oct. 06, 2012
RF CABLE	NA	RF104-201 RF104-203 RF104-204	Dec. 27, 2010	Dec. 26, 2011
RF Cable	NA	CHGCAB_001	Oct. 07, 2011	Oct. 06, 2012
Software	ADT_Radiated_V8.7.05	NA	NA	NA
CT Antenna Tower & Turn Table	NA	NA	NA	NA

Note: 1. The calibration interval of the above test instruments is 12 months and the calibrations are traceable to NML/ROC and NIST/USA.

2. The horn antenna, preamplifier (model: 8449B) are used only for the measurement of emission frequency above 1GHz if tested.

3. The test was performed in 966 Chamber No. G.

4. The FCC Site Registration No. is 966073.

5. The VCCI Site Registration No. is G-137.

6. The CANADA Site Registration No. is IC 7450H-2.



4.2.3 TEST PROCEDURES

- a. The EUT was placed on the top of a rotating table 0.8 meters above the ground at a 3 meter chamber room. The table was rotated 360 degrees to determine the position of the highest radiation.
- b. The EUT was set 3 meters away from the interference-receiving antenna, which was mounted on the top of a variable-height antenna tower.
- c. The height of antenna is varied from one meter to four meters above the ground to determine the maximum value of the field strength. Both horizontal and vertical polarizations of the antenna are set to make the measurement.
- d. For each suspected emission, the EUT was arranged to its worst case and then the antenna was tuned to heights from 1 meter to 4 meters and the rotatable table was turned from 0 degrees to 360 degrees to find the maximum reading.
- e. The test-receiver system was set to quasi-peak detect function and specified bandwidth with maximum hold mode when the test frequency is below 1 GHz.
- f. The test-receiver system was set to peak and average detect function and specified bandwidth with maximum hold mode when the test frequency is above 1 GHz. If the peak reading value also meets average limit, measurement with the average detector is unnecessary.

NOTE:

1. The resolution bandwidth and video bandwidth of test receiver/spectrum analyzer is 120kHz for Quasi-peak detection (QP) at frequency below 1GHz.
2. The resolution bandwidth of test receiver/spectrum analyzer is 1 MHz and the video bandwidth is 3 MHz for Peak detection (PK) at frequency above 1GHz.
3. The resolution bandwidth of test receiver/spectrum analyzer is 1 MHz and the video bandwidth is 10 Hz for Average detection (AV) at frequency above 1GHz.

4.2.4 DEVIATION FROM TEST STANDARD

No deviation

4.2.5 TEST SETUP

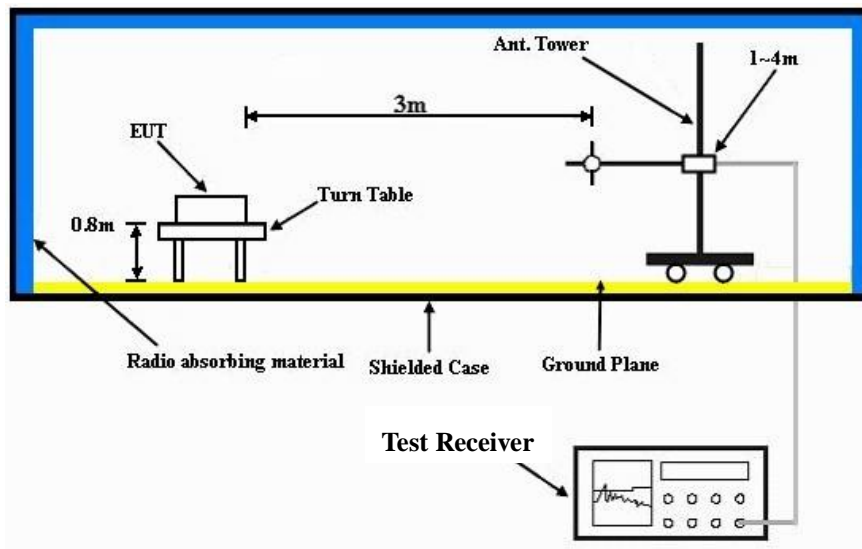

For the actual test configuration, please refer to the related item – Photographs of the Test Configuration.

4.2.6 EUT OPERATING CONDITIONS

Same as 4.1.6



4.2.7 TEST RESULTS

BELOW 1GHz DATA :

EUT TEST CONDITION		MEASUREMENT DETAIL	
CHANNEL	11a : Ch157 8DBPSK : Ch0	FREQUENCY RANGE	Below 1000MHz
INPUT POWER	DC 3.3V	DETECTOR FUNCTION	Quasi-Peak
ENVIRONMENTAL CONDITIONS	18deg. C, 64%RH	TESTED BY	Nick Chang

ANTENNA POLARITY & TEST DISTANCE: HORIZONTAL AT 3 M								
NO.	FREQ. (MHz)	EMISSION LEVEL (dBuV/m)	LIMIT (dBuV/m)	MARGIN (dB)	ANTENNA HEIGHT (m)	TABLE ANGLE (Degree)	RAW VALUE (dBuV)	CORRECTION FACTOR (dB/m)
1	34.26	31.4 QP	40.0	-8.6	1.00 H	237	18.06	13.38
2	216.04	38.6 QP	46.0	-7.4	1.00 H	300	26.63	11.98
3	304.50	41.1 QP	46.0	-4.9	1.00 H	88	25.57	15.50
4	522.06	31.5 QP	46.0	-14.5	1.51 H	249	10.96	20.55
5	604.94	37.2 QP	46.0	-8.8	1.49 H	260	14.88	22.28
6	696.01	31.0 QP	46.0	-15.0	1.01 H	239	7.90	23.06
7	848.66	34.7 QP	46.0	-11.4	1.49 H	358	8.45	26.20
ANTENNA POLARITY & TEST DISTANCE: VERTICAL AT 3 M								
NO.	FREQ. (MHz)	EMISSION LEVEL (dBuV/m)	LIMIT (dBuV/m)	MARGIN (dB)	ANTENNA HEIGHT (m)	TABLE ANGLE (Degree)	RAW VALUE (dBuV)	CORRECTION FACTOR (dB/m)
1	40.78	35.4 QP	40.0	-4.6	1.01 V	2	21.23	14.17
2	149.13	28.7 QP	43.5	-14.8	1.01 V	252	14.07	14.62
3	259.27	28.3 QP	46.0	-17.8	1.51 V	304	14.60	13.65
4	334.46	30.2 QP	46.0	-15.8	1.51 V	275	14.06	16.17
5	480.01	27.8 QP	46.0	-18.2	1.01 V	289	8.24	19.58
6	650.06	29.6 QP	46.0	-16.4	1.01 V	291	6.98	22.60
7	848.18	33.3 QP	46.0	-12.7	1.48 V	110	7.14	26.19

- REMARKS:**
1. Emission level (dBuV/m) = Raw Value (dBuV) + Correction Factor (dB/m).
 2. Correction Factor (dB/m) = Antenna Factor (dB/m) + Cable Factor (dB).
 3. The other emission levels were very low against the limit.
 4. Margin value = Emission level – Limit value.



A D T

ABOVE 1GHz DATA

EUT TEST CONDITION		MEASUREMENT DETAIL	
CHANNEL	11a : Ch157 8DBPSK : Ch0	FREQUENCY RANGE	1 ~ 40GHz
INPUT POWER	DC 3.3V	DETECTOR FUNCTION	Peak (PK) Average (AV)
ENVIRONMENTAL CONDITIONS	19deg. C, 66%RH	TESTED BY	Kent Liu

ANTENNA POLARITY & TEST DISTANCE: HORIZONTAL AT 3 M

NO.	FREQ. (MHz)	EMISSION LEVEL (dBuV/m)	LIMIT (dBuV/m)	MARGIN (dB)	ANTENNA HEIGHT (m)	TABLE ANGLE (Degree)	RAW VALUE (dBuV)	CORRECTION FACTOR (dB/m)
1	4960.00	50.3 PK	74.0	-23.7	1.73 H	122	10.50	39.81
2	4960.00	37.6 AV	54.0	-16.4	1.73 H	122	-2.19	39.81
3	7440.00	55.5 PK	74.0	-18.5	1.36 H	33	8.77	46.74
4	7440.00	42.8 AV	54.0	-11.2	1.36 H	33	-3.98	46.74
5	11570.00	55.5 PK	74.0	-18.6	1.35 H	13	7.26	48.19
6	11570.00	44.6 AV	54.0	-9.4	1.35 H	13	-3.61	48.19

ANTENNA POLARITY & TEST DISTANCE: VERTICAL AT 3 M

NO.	FREQ. (MHz)	EMISSION LEVEL (dBuV/m)	LIMIT (dBuV/m)	MARGIN (dB)	ANTENNA HEIGHT (m)	TABLE ANGLE (Degree)	RAW VALUE (dBuV)	CORRECTION FACTOR (dB/m)
1	4960.00	50.3 PK	74.0	-23.7	1.26 V	287	10.53	39.81
2	4960.00	38.0 AV	54.0	-16.0	1.26 V	287	-1.81	39.81
3	7440.00	57.1 PK	74.0	-16.9	1.11 V	231	10.34	46.74
4	7440.00	47.0 AV	54.0	-7.1	1.11 V	231	0.21	46.74
5	11570.00	55.7 PK	74.0	-18.3	1.51 V	308	7.48	48.19
6	11570.00	44.9 AV	54.0	-9.1	1.51 V	308	-3.26	48.19

- REMARKS:**
1. Emission level (dBuV/m) = Raw Value (dBuV) + Correction Factor (dB/m).
 2. Correction Factor (dB/m) = Antenna Factor (dB/m) + Cable Factor (dB).
 3. The other emission levels were very low against the limit.
 4. Margin value = Emission level – Limit value.



A D T

4. INFORMATION ON THE TESTING LABORATORIES

We, Bureau Veritas Consumer Products Services (H.K.) Ltd., Taoyuan Branch, were founded in 1988 to provide our best service in EMC, Radio, Telecom and Safety consultation. Our laboratories are accredited and approved according to ISO/IEC 17025.

Copies of accreditation and authorization certificates of our laboratories obtained from approval agencies can be downloaded from our web site:

www.adt.com.tw/index.5.phtml.

If you have any comments, please feel free to contact us at the following:

Linko EMC/RF Lab:

Tel: 886-2-26052180

Fax: 886-2-26052943

Hsin Chu EMC/RF Lab:

Tel: 886-3-5935343

Fax: 886-3-5935342

Hwa Ya EMC/RF/Safety/Telecom Lab:

Tel: 886-3-3183232

Fax: 886-3-3185050

Email: service.adt@tw.bureauveritas.com

Web Site: www.adt.com.tw

The address and road map of all our labs can be found in our web site also.

---END---