



A D T

FCC TEST REPORT (15.247)

REPORT NO.: RF111028C08A

MODEL NO.: 21-148603-0B

FCC ID: UZ7211486030B

RECEIVED: Oct. 28, 2011

TESTED: Nov. 14 to Dec. 01, 2011

ISSUED: Mar. 09, 2012

APPLICANT: Motorola Solutions, Inc.

ADDRESS: 1 Motorola Plaza, Holtsville, NY 11742-1300
USA

ISSUED BY: Bureau Veritas Consumer Products Services
(H.K.) Ltd., Taoyuan Branch Hsin Chu Laboratory

LAB ADDRESS : No. 81-1, Lu Liao Keng, 9th Ling,Wu Lung Tsuen,
Chiung Lin Hsiang, Hsin Chu Hsien 307, Taiwan

TEST LOCATION (1): No. 81-1, Lu Liao Keng, 9th Ling,Wu Lung Tsuen,
Chiung Lin Hsiang, Hsin Chu Hsien 307, Taiwan

TEST LOCATION (2): No. 49, Ln. 206, Wende Rd., Shangshan Tsuen,
Chiung Lin Hsiang, Hsin Chu Hsien 307, Taiwan

This test report consists of 154 pages in total. It may be duplicated completely for legal use with the approval of the applicant. It should not be reproduced except in full, without the written approval of our laboratory. The client should not use it to claim product certification, approval, or endorsement by TAF or any government agencies. The test results in the report only apply to the tested sample.





A D T

Table of Contents

RELEASE CONTROL RECORD	5
1. CERTIFICATION	6
2. SUMMARY OF TEST RESULTS	7
2.1 MEASUREMENT UNCERTAINTY	9
3. GENERAL INFORMATION	10
3.1 GENERAL DESCRIPTION OF EUT	10
3.2 DESCRIPTION OF TEST MODES	12
3.2.1 TEST MODE APPLICABILITY AND TESTED CHANNEL DETAIL	13
3.3 GENERAL DESCRIPTION OF APPLIED STANDARDS	16
3.4 DESCRIPTION OF SUPPORT UNITS.....	17
3.5 CONFIGURATION OF SYSTEM UNDER TEST	18
4. TEST TYPES AND RESULTS (802.11b & g, 2400 ~ 2483.5MHz Band)	19
4.1 CONDUCTED EMISSION MEASUREMENT	19
4.1.1 LIMITS OF CONDUCTED EMISSION MEASUREMENT	19
4.1.2 TEST INSTRUMENTS.....	19
4.1.3 TEST PROCEDURES	20
4.1.4 DEVIATION FROM TEST STANDARD	20
4.1.5 TEST SETUP	21
4.1.6 EUT OPERATING CONDITIONS	21
4.1.7 TEST RESULTS	22
4.2 RADIATED EMISSION MEASUREMENT	24
4.2.1 LIMITS OF RADIATED EMISSION MEASUREMENT	24
4.2.2 TEST INSTRUMENTS.....	25
4.2.3 TEST PROCEDURES	27
4.2.4 DEVIATION FROM TEST STANDARD	27
4.2.5 TEST SETUP	28
4.2.6 EUT OPERATING CONDITIONS	28
4.2.7 TEST RESULTS	29
4.3 6dB BANDWIDTH MEASUREMENT	99
4.3.1 LIMITS OF 6dB BANDWIDTH MEASUREMENT	99
4.3.2 TEST INSTRUMENTS.....	99
4.3.3 TEST PROCEDURE.....	99
4.3.4 DEVIATION FROM TEST STANDARD	99
4.3.5 TEST SETUP	99
4.3.6 EUT OPERATING CONDITIONS	99
4.3.7 TEST RESULTS	100
4.4 MAXIMUM PEAK OUTPUT POWER.....	103
4.4.1 LIMITS OF MAXIMUM PEAK OUTPUT POWER MEASUREMENT	103
4.4.2 INSTRUMENTS.....	103
4.4.3 TEST PROCEDURES	103



4.4.4	DEVIATION FROM TEST STANDARD	103
4.4.5	TEST SETUP	103
4.4.6	EUT OPERATING CONDITIONS	103
4.4.7	TEST RESULTS	104
4.5	POWER SPECTRAL DENSITY MEASUREMENT	106
4.5.1	LIMITS OF POWER SPECTRAL DENSITY MEASUREMENT	106
4.5.2	TEST INSTRUMENTS.....	106
4.5.3	TEST PROCEDURE.....	106
4.5.4	DEVIATION FROM TEST STANDARD	106
4.5.5	TEST SETUP	106
4.5.6	EUT OPERATING CONDITION.....	106
4.5.7	TEST RESULTS	107
4.6	CONDUCTED OUT-BAND EMISSION MEASUREMENT	110
4.6.1	LIMITS OF CONDUCTED OUT-BAND EMISSION MEASUREMENT.....	110
4.6.2	TEST INSTRUMENTS.....	110
4.6.3	TEST PROCEDURE.....	110
4.6.4	DEVIATION FROM TEST STANDARD	110
4.6.5	EUT OPERATING CONDITION	110
4.6.6	TEST RESULTS	110
5.	TEST TYPES AND RESULTS (802.11a, 5725~5850MHz Band).....	123
5.1	CONDUCTED EMISSION MEASUREMENT	123
5.1.1	LIMITS OF CONDUCTED EMISSION MEASUREMENT	123
5.1.2	TEST INSTRUMENTS.....	123
5.1.3	TEST PROCEDURES	124
5.1.4	DEVIATION FROM TEST STANDARD	124
5.1.5	TEST SETUP	125
5.1.6	EUT OPERATING CONDITIONS	125
5.1.7	TEST RESULTS	126
5.2	RADIATED EMISSION MEASUREMENT	128
5.2.1	LIMITS OF RADIATED EMISSION MEASUREMENT	128
5.2.2	TEST INSTRUMENTS.....	129
5.2.3	TEST PROCEDURES	131
5.2.4	DEVIATION FROM TEST STANDARD	131
5.2.5	TEST SETUP	132
5.2.6	EUT OPERATING CONDITIONS	132
5.2.7	TEST RESULTS	133
5.3	6dB BANDWIDTH MEASUREMENT	140
5.3.1	LIMITS OF 6dB BANDWIDTH MEASUREMENT	140
5.3.2	TEST INSTRUMENTS.....	140
5.3.3	TEST PROCEDURE.....	140
5.3.4	DEVIATION FROM TEST STANDARD	140
5.3.5	TEST SETUP	140



A D T

5.3.6	EUT OPERATING CONDITIONS	140
5.3.7	TEST RESULTS	141
5.4	MAXIMUM PEAK OUTPUT POWER.....	143
5.4.1	LIMITS OF MAXIMUM PEAK OUTPUT POWER MEASUREMENT	143
5.4.2	INSTRUMENTS.....	143
5.4.3	TEST PROCEDURES	143
5.4.4	DEVIATION FROM TEST STANDARD.....	143
5.4.5	TEST SETUP	143
5.4.6	EUT OPERATING CONDITIONS	143
5.4.7	TEST RESULTS	144
5.5	POWER SPECTRAL DENSITY MEASUREMENT.....	145
5.5.1	LIMITS OF POWER SPECTRAL DENSITY MEASUREMENT	145
5.5.2	TEST INSTRUMENTS.....	145
5.5.3	TEST PROCEDURE.....	145
5.5.4	DEVIATION FROM TEST STANDARD.....	145
5.5.5	TEST SETUP	145
5.5.6	EUT OPERATING CONDITION.....	145
5.5.7	TEST RESULTS	146
5.6	CONDUCTED OUT-BAND EMISSION MEASUREMENT.....	148
5.6.1	LIMITS OF CONDUCTED OUT-BAND EMISSION MEASUREMENT.....	148
5.6.2	TEST INSTRUMENTS.....	148
5.6.3	TEST PROCEDURE.....	148
5.6.4	DEVIATION FROM TEST STANDARD.....	148
5.6.5	EUT OPERATING CONDITION.....	148
5.6.6	TEST RESULTS	148
6.	INFORMATION ON THE TESTING LABORATORIES	153
7.	APPENDIX A - MODIFICATIONS RECORDERS FOR ENGINEERING CHANGES TO THE EUT BY THE LAB.....	154



A D T

RELEASE CONTROL RECORD

ISSUE NO.	REASON FOR CHANGE	DATE ISSUED
RF111028C08A	Original release	Mar. 09, 2012



A D T

1. CERTIFICATION

PRODUCT: Radio Module
BRAND NAME: Motorola
MODEL NO.: 21-148603-0B
TEST SAMPLE: ENGINEERING SAMPLE
APPLICANT: Motorola Solutions, Inc.
TESTED: Nov. 14 to Dec. 01, 2011
STANDARDS: FCC Part 15, Subpart C (Section 15.247)
ANSI C63.4-2003
ANSI C63.10-2009

The above equipment (Model: 21-148603-0B) has been tested by **Bureau Veritas Consumer Products Services (H.K.) Ltd., Taoyuan Branch**, and found compliance with the requirement of the above standards. The test record, data evaluation & Equipment Under Test (EUT) configurations represented herein are true and accurate accounts of the measurements of the sample's EMC characteristics under the conditions specified in this report.

PREPARED BY : , **DATE:** Mar. 09, 2012
(Midoli Peng, Specialist)

APPROVED BY : , **DATE:** Mar. 09, 2012
(May Chen, Deputy Manager)

2. SUMMARY OF TEST RESULTS

The EUT has been tested according to the following specifications:

For 2.4GHz, 2412~2462MHz Band

APPLIED STANDARD: FCC Part 15, Subpart C			
Standard Section	Test Type and Limit	Result	Remark
15.207	AC Power Conducted Emission	PASS	Meet the requirement of limit. Minimum passing margin is -25.56dB at 9.221MHz
15.247(a)(2)	Spectrum Bandwidth of a Direct Sequence Spread Spectrum System Limit: min. 500kHz	PASS	Meet the requirement of limit.
15.247(b)	Maximum Peak Output Power Limit: max. 30dBm	PASS	Meet the requirement of limit.
15.247(d)	Radiated Emissions Limit: Table 15.209	PASS	Meet the requirement of limit. Minimum passing margin is -1.1dB at 2486.77MHz, 2390.0MHz & 2483.5MHz
15.247(e)	Power Spectral Density Limit: max. 8dBm	PASS	Meet the requirement of limit.
15.247(d)	Conducted Out-Band Emission Measurement Limit: 20dB less than the peak value of fundamental frequency	PASS	Meet the requirement of limit.
15.203	Antenna Requirement	PASS	Antenna connector is Reverse SMA not a standard connector.



A D T

For 5GHz, 5725~5850MHz Band

APPLIED STANDARD: FCC Part 15, Subpart C			
Standard Section	Test Type and Limit	Result	Remark
15.207	AC Power Conducted Emission	PASS	Meet the requirement of limit. Minimum passing margin is -25.84dB at 9.215MHz
15.247(a)(2)	Spectrum Bandwidth of a Direct Sequence Spread Spectrum System Limit: min. 500kHz	PASS	Meet the requirement of limit.
15.247(b)	Maximum Peak Output Power Limit: max. 30dBm	PASS	Meet the requirement of limit.
15.247(d)	Radiated Emissions Limit: Table 15.209	PASS	Meet the requirement of limit. Minimum passing margin is -8.0dB at 11650.0MHz
15.247(e)	Power Spectral Density Limit: max. 8dBm	PASS	Meet the requirement of limit.
15.247(d)	Conducted Out-Band Emission Measurement Limit: 20dB less than the peak value of fundamental frequency	PASS	Meet the requirement of limit.
15.203	Antenna Requirement	PASS	Antenna connector is Reverse SMA not a standard connector.

NOTE:

1. The EUT was operating in 2400 ~ 2483.5MHz, 5.15~5.35GHz, 5.47~5.6GHz & 5.65~5.725GHz and 5.725~5.850GHz frequencies band. This report was recorded the RF parameters including 2400 ~ 2483.5MHz and 5.725~5.850GHz. For the 5.15~5.35GHz, 5.47~5.6GHz & 5.65~5.725GHz RF parameters was recorded in another test report.



A D T

2.1 MEASUREMENT UNCERTAINTY

Where relevant, the following measurement uncertainty levels have been estimated for tests performed on the EUT as specified in CISPR 16-4-2:

This uncertainty represents an expanded uncertainty expressed at approximately the 95% confidence level using a coverage factor of $k=2$.

Measurement	Value
Conducted emissions	2.45 dB
Radiated emissions (30MHz-1GHz)	3.89 dB
Radiated emissions (1GHz -18GHz)	2.19 dB
Radiated emissions (18GHz -40GHz)	2.56 dB



A D T

3. GENERAL INFORMATION

3.1 GENERAL DESCRIPTION OF EUT

PRODUCT	Radio Module
MODEL NO.	21-148603-0B
FCC ID	UZ7211486030B
POWER SUPPLY	DC 3.3V
MODULATION TYPE	CCK, DQPSK, DBPSK for DSSS 64QAM, 16QAM, QPSK, BPSK for OFDM
MODULATION TECHNOLOGY	DSSS, OFDM
TRANSFER RATE	802.11b: up to 11Mbps 802.11g: up to 54Mbps 802.11n (20MHz, 800ns GI): up to 72.2Mbps 802.11n (20MHz, 400ns GI): up to 65Mbps
OPERATING FREQUENCY	For 15.407 802.11a: 5.18 ~ 5.24GHz, 5.26 ~ 5.32GHz, 5.5~5.58GHz & 5.66~5.7GHz
	For 15.247 802.11b & 802.11g: 2.412 ~ 2.472GHz 802.11a: 5.745 ~ 5.825GHz
NUMBER OF CHANNEL	For 15.407 16 for 802.11a, 802.11n (20MHz)
	For 15.247(2.4GHz) 13 for 802.11b, 802.11g, 802.11n (20MHz)
	For 15.247(5GHz) 5 for 802.11a, 802.11n (20MHz)
MAXIMUM OUTPUT POWER	For 15.407 802.11a: 102.3mW 802.11n (20MHz): 89.1mW
	For 15.247(2.4GHz) 802.11b: 208.9mW 802.11g: 257.0mW 802.11n (20MHz): 251.2mW
	For 15.247(5GHz) 802.11a: 158.5mW 802.11n (20MHz): 154.9mW
ANTENNA TYPE	Please see note
DATA CABLE	NA



A D T

I/O PORTS	NA
ASSOCIATED DEVICES	NA

NOTE:

1. There are Bluetooth technology, GPS technology and WLAN technology used for the EUT and the functions of EUT listed as below table:

Function	Report No.
WLAN	RF111028C08A (FCC Part15C) RF111028C08A-1(FCC Part15E)
Bluetooth	RF111028C08A-2

2. The antennas provided to the EUT, please refer to the following table:

No.	Type	Connector	Model	Peak Gain (dBi)	Cable loss (dB)	Net Peak Gain (dBi)	Trace
1	Dipole-1	Reverse SMA	ML-2452-APA2-01 Rev C	2.4GHz : 3 5GHz : 5	2.4GHz : 0.75 5GHz : 1.3	2.4GHz : 2.25 5GHz : 3.7	WiFi
2	Dipole-2	Reverse SMA	C492-510032-A	1.8	2.35	-0.55	BT
3	Chip	Reverse SMA	NA	-	-		GPS

3. The EUT was included two SKU, which are identical to each other in all aspects except for the following table:

	P/N	Description
SKU #1	21-148603-02	Diversity version with WLAN and BT on SEPARATE RF paths
SKU #2	21-148603-04	NON-Diversity version with WLAN and BT on SEPARATE RF paths

SKU #1, the worse case one, was chosen for final test.

4. Spurious Emission of the simultaneous operation (WiFi & Bluetooth) have been evaluated and no non-compliance found. (The device can transmit simultaneously on WLAN (5GHz) mode and Bluetooth mode; other modes can't support simultaneously ability.)
5. The EUT is 1 * 1 spatial SISO (1Tx & 1Rx) without beam forming function.
6. The above EUT information was declared by the manufacturer and for more detailed features description, please refer to the manufacturer's specifications or User's manual.

3.2 DESCRIPTION OF TEST MODES

Operated in 2400 ~ 2483.5MHz band:

Thirteen channels are provided for 802.11b, 802.11g, 802.11n (20MHz):

CHANNEL	FREQUENCY	CHANNEL	FREQUENCY
1	2412MHz	8	2447MHz
2	2417MHz	9	2452MHz
3	2422MHz	10	2457MHz
4	2427MHz	11	2462MHz
5	2432MHz	12	2467MHz
6	2437MHz	13	2472MHz
7	2442MHz		

Operated in 5725 ~ 5850MHz band:

Five channels are provided for 802.11a, 802.11n (20MHz):

CHANNEL	FREQUENCY	CHANNEL	FREQUENCY
149	5745 MHz	161	5805 MHz
153	5765 MHz	165	5825 MHz
157	5785 MHz		

3.2.1 TEST MODE APPLICABILITY AND TESTED CHANNEL DETAIL

EUT CONFIGURE MODE	APPLICABLE TO					DESCRIPTION
	PLC	RE < 1G	RE ≥ 1G	APCM	OB	
1	√	√	√	√	√	-

Where **PLC**: Power Line Conducted Emission **RE < 1G**: Radiated Emission below 1GHz
RE ≥ 1G: Radiated Emission above 1GHz **APCM**: Antenna Port Conducted Measurement
OB: Conducted Out-Band Emission Measurement

POWER LINE CONDUCTED EMISSION TEST:

- Pre-Scan has been conducted to determine the worst-case mode from all possible combinations between available modulations, data rates and antenna ports (if EUT with antenna diversity architecture).
- Following channel(s) was (were) selected for the final test as listed below.

MODE	AVAILABLE CHANNEL	TESTED CHANNEL	MODULATION TECHNOLOGY	MODULATION TYPE	DATA RATE (Mbps)
802.11g	1 to 11	6	OFDM	BPSK	6
802.11a	149 to 165	157	OFDM	BPSK	6

RADIATED EMISSION TEST (BELOW 1 GHz):

- Pre-Scan has been conducted to determine the worst-case mode from all possible combinations between available modulations, data rates and antenna ports (if EUT with antenna diversity architecture).
- Following channel(s) was (were) selected for the final test as listed below.

MODE	AVAILABLE CHANNEL	TESTED CHANNEL	MODULATION TECHNOLOGY	MODULATION TYPE	DATA RATE (Mbps)
802.11g	1 to 13	6	OFDM	BPSK	6
802.11a	149 to 165	157	OFDM	BPSK	6



A D T

RADIATED EMISSION TEST (ABOVE 1 GHz):

- Pre-Scan has been conducted to determine the worst-case mode from all possible combinations between available modulations, data rates and antenna ports (if EUT with antenna diversity architecture).
- Following channel(s) was (were) selected for the final test as listed below.

MODE	AVAILABLE CHANNEL	TESTED CHANNEL	MODULATION TECHNOLOGY	MODULATION TYPE	DATA RATE (Mbps)
802.11b	1 to 13	1, 2, 6, 10, 11, 12, 13	DSSS	DBPSK	1
802.11g	1 to 13	1, 2, 3, 6, 9, 10, 11, 12, 13	OFDM	BPSK	6
For 2.4 GHz 802.11n (20MHz)	1 to 13	1, 2, 3, 6, 9, 10, 11, 12, 13	OFDM	BPSK	6.5
802.11a	149 to 165	149, 157, 165	OFDM	BPSK	6
For 5 GHz 802.11n (20MHz)	149 to 165	149, 157, 165	OFDM	BPSK	6.5

ANTENNA PORT CONDUCTED MEASUREMENT:

- This item includes all test value of each mode, but only includes spectrum plot of worst value of each mode.
- Pre-Scan has been conducted to determine the worst-case mode from all possible combinations between available modulations, data rates and antenna ports (if EUT with antenna diversity architecture).
- Following channel(s) was (were) selected for the final test as listed below.

MODE	AVAILABLE CHANNEL	TESTED CHANNEL	MODULATION TECHNOLOGY	MODULATION TYPE	DATA RATE (Mbps)
802.11b	1 to 13	1, 2, 6, 10, 11, 12, 13	DSSS	DBPSK	1
802.11g	1 to 13	1, 2, 3, 6, 9, 10, 11, 12, 13	OFDM	BPSK	6
For 2.4 GHz 802.11n (20MHz)	1 to 13	1, 2, 3, 6, 9, 10, 11, 12, 13	OFDM	BPSK	6.5
802.11a	149 to 165	149, 157, 165	OFDM	BPSK	6
For 5 GHz 802.11n (20MHz)	149 to 165	149, 157, 165	OFDM	BPSK	6.5



A D T

CONDUCTED OUT-BAND EMISSION MEASUREMENT:

- Pre-Scan has been conducted to determine the worst-case mode from all possible combinations between available modulations, data rates and antenna ports (if EUT with antenna diversity architecture).
- Following channel(s) was (were) selected for the final test as listed below.

MODE	AVAILABLE CHANNEL	TESTED CHANNEL	MODULATION TECHNOLOGY	MODULATION TYPE	DATA RATE (Mbps)
802.11b	1 to 13	1, 11, 12, 13	DSSS	DBPSK	1
802.11g	1 to 13	1, 11, 12, 13	OFDM	BPSK	6
For 2.4 GHz 802.11n (20MHz)	1 to 13	1, 11, 12, 13	OFDM	BPSK	6.5
802.11a	149 to 165	149, 165	OFDM	BPSK	6
For 5 GHz 802.11n (20MHz)	149 to 165	149, 165	OFDM	BPSK	6.5

TEST CONDITION:

APPLICABLE TO	ENVIRONMENTAL CONDITIONS	INPUT POWER	TESTED BY
PLC	26deg. C, 68%RH	120Vac, 60Hz(system)	Andy Ho
RE<1G	18deg. C, 64%RH	DC 3.3V	Nick Chang
RE ³ 1G	19deg. C, 66%RH	DC 3.3V	Kent Liu
APCM	25deg. C, 60%RH	DC 3.3V	Kent Liu
OB	25deg. C, 60%RH	DC 3.3V	Kent Liu

3.3 GENERAL DESCRIPTION OF APPLIED STANDARDS

The EUT is a RF product. According to the specifications of the manufacturer, it must comply with the requirements of the following standards:

FCC Part 15, Subpart C. (15.247)

ANSI C63.4-2003

ANSI C63.10-2009

All test items have been performed and recorded as per the above standards.

NOTE: The EUT is also considered as a kind of computer peripheral, because the connection to computer is necessary for typical use. It has been verified to comply with the requirements of FCC Part 15, Subpart B, Class B (DoC). The test report has been issued separately.



A D T

3.4 DESCRIPTION OF SUPPORT UNITS

The EUT has been tested as an independent unit together with other necessary accessories or support units. The following support units or accessories were used to form a representative test configuration during the tests.

No.	Product	Brand	Model No.	Serial No.	FCC ID
1	NOTEBOOK COMPUTER	DELL	PP32LA	FSLB32S	FCC DoC
2	DC POWER SUPPLY	Topward	6603D	795558	NA

No.	Signal cable description
1	USB cable (1.8m with one core)
2	DC line (2m)

Note: 1. All power cords of the above support units are unshielded (1.8m).

3.5 CONFIGURATION OF SYSTEM UNDER TEST

For Conducted emission test:

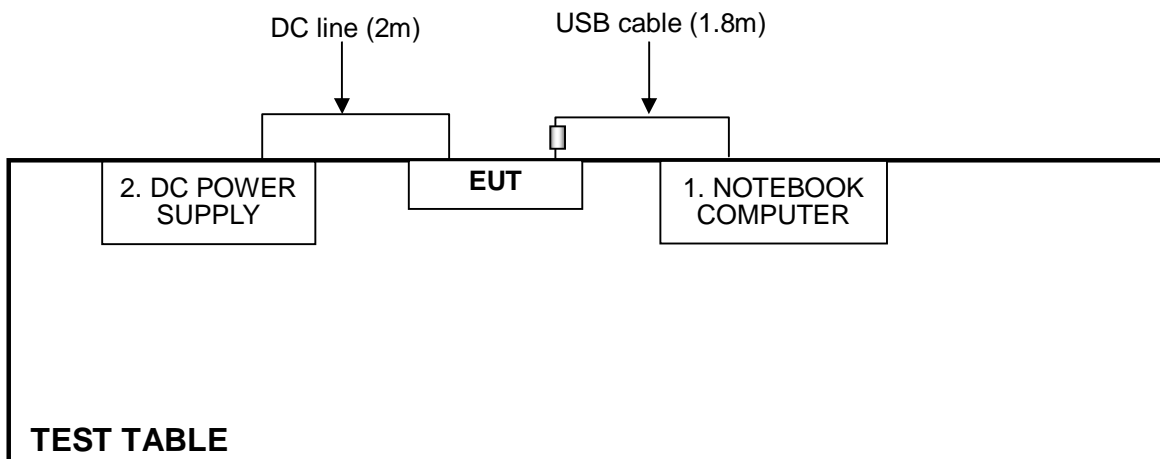

For other test items:

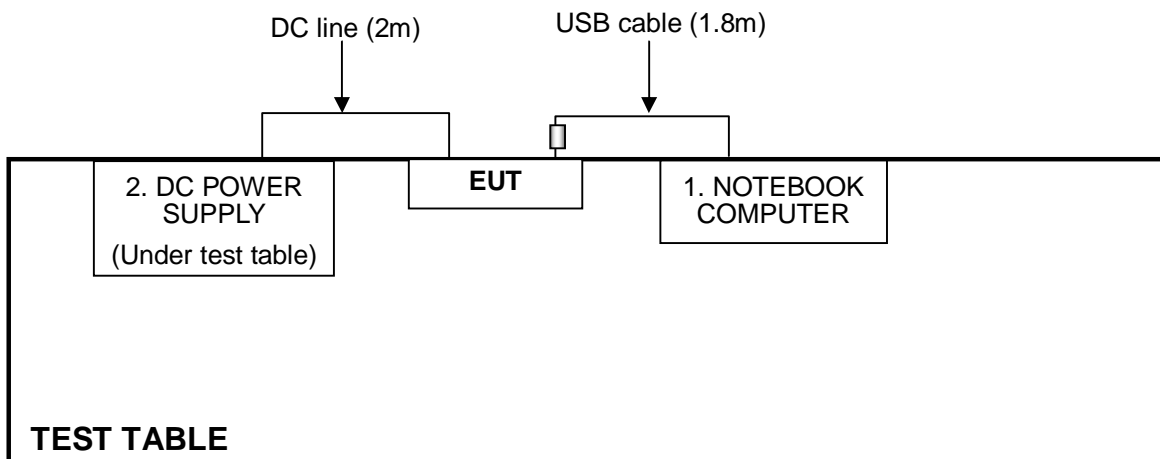



A D T

4. TEST TYPES AND RESULTS (802.11b & g, 2400 ~ 2483.5MHz Band)

4.1 CONDUCTED EMISSION MEASUREMENT

4.1.1 LIMITS OF CONDUCTED EMISSION MEASUREMENT

FREQUENCY OF EMISSION (MHz)	CONDUCTED LIMIT (dBµV)	
	Quasi-peak	Average
0.15-0.5	66 to 56	56 to 46
0.5-5	56	46
5-30	60	50

- NOTE:**
1. The lower limit shall apply at the transition frequencies.
 2. The limit decreases in line with the logarithm of the frequency in the range of 0.15 to 0.50 MHz.

4.1.2 TEST INSTRUMENTS

Test date: Nov. 14, 2011

DESCRIPTION & MANUFACTURER	MODEL NO.	SERIAL NO.	CALIBRATED DATE	CALIBRATED UNTIL
Test Receiver	ESCS 30	100375	Mar. 09, 2011	Mar. 08, 2012
Line-Impedance Stabilization Network (for EUT)	NSLK8127	8127-522	Sep. 07, 2011	Sep. 06, 2012
Line-Impedance Stabilization Network (for Peripheral)	ESH3-Z5	848773/004	Nov. 01, 2011	Oct. 31, 2012
RF Cable (JYBAO)	5DFB	COCCAB-002	Aug. 29, 2011	Aug. 28, 2012
50 ohms Terminator	50	3	Nov. 02, 2011	Nov. 01, 2012
Software	BV ADT_Cond_V7.3.7	NA	NA	NA

Note:

1. The calibration interval of the above test instruments is 12 months and the calibrations are traceable to NML/ROC and NIST/USA.
2. The test was performed in Shielded Room No. C.
3. The VCCI Con C Registration No. is C-3611.

4.1.3 TEST PROCEDURES

- a. The EUT was placed 0.4 meters from the conducting wall of the shielded room with EUT being connected to the power mains through a line impedance stabilization network (LISN). Other support units were connected to the power mains through another LISN. The two LISNs provide 50 ohm/ 50uH of coupling impedance for the measuring instrument.
- b. Both lines of the power mains connected to the EUT were checked for maximum conducted interference.
- c. The frequency range from 150kHz to 30MHz was searched. Emission levels under (Limit - 20dB) were not recorded.

4.1.4 DEVIATION FROM TEST STANDARD

No deviation

4.1.5 TEST SETUP

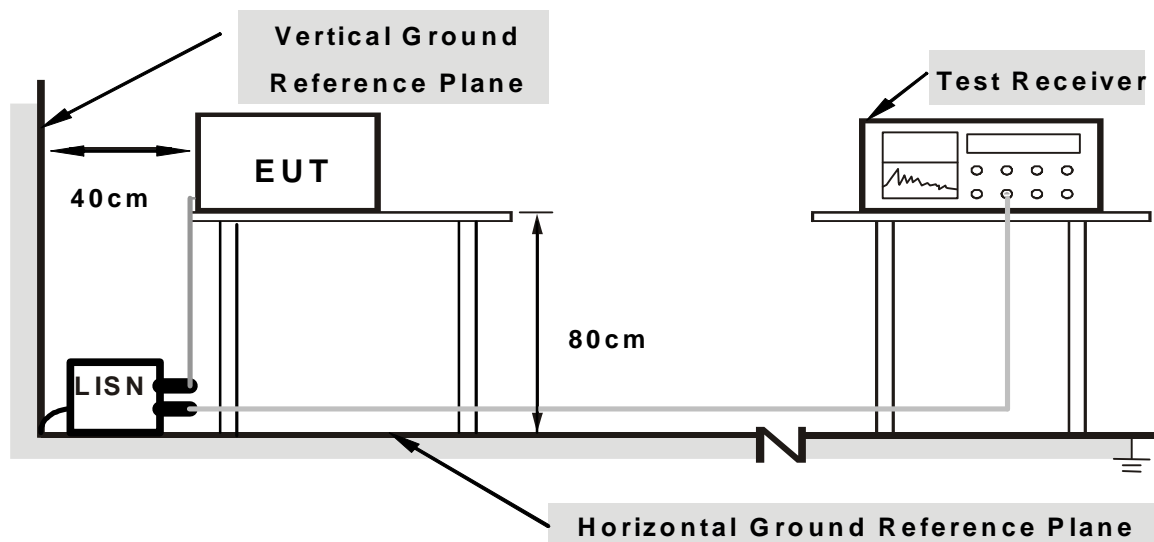

Note: 1. Support units were connected to second LISN.

2. Both of LISNs (AMN) are 80 cm from EUT and at least 80 from other units and other metal planes

For the actual test configuration, please refer to the related item – Photographs of the Test Configuration.

4.1.6 EUT OPERATING CONDITIONS

1. Connect the EUT with the support unit 1 (Notebook Computer) which is placed on a testing table.
2. The communication partner run test program “RTTT.exe” to enable EUT under transmission/receiving condition continuously at specific channel frequency.

4.1.7 TEST RESULTS

PHASE	Line (L)	6dB BANDWIDTH	9 kHz
--------------	----------	----------------------	-------

No	Freq.	Corr.	Reading Value		Emission Level		Limit		Margin	
	[MHz]	Factor	[dB (uV)]		[dB (uV)]		[dB (uV)]		(dB)	
		(dB)	Q.P.	AV.	Q.P.	AV.	Q.P.	AV.	Q.P.	AV.
1	0.209	0.10	14.50	3.89	14.60	3.99	63.26	53.26	-48.66	-49.27
2	0.283	0.10	8.79	6.64	8.89	6.74	60.73	50.73	-51.84	-43.99
3	0.431	0.11	7.06	5.72	7.17	5.83	57.23	47.23	-50.06	-41.40
4	5.375	0.37	22.52	15.61	22.89	15.98	60.00	50.00	-37.11	-34.02
5	9.221	0.52	28.39	23.92	28.91	24.44	60.00	50.00	-31.09	-25.56
6	11.945	0.59	26.12	21.86	26.71	22.45	60.00	50.00	-33.29	-27.55
7	14.678	0.66	22.86	18.43	23.52	19.09	60.00	50.00	-36.48	-30.91

- REMARKS:**
1. Q.P. and AV. are abbreviations of quasi-peak and average individually.
 2. The emission levels of other frequencies were very low against the limit.
 3. Margin value = Emission level - Limit value
 4. Correction factor = Insertion loss + Cable loss
 5. Emission Level = Correction Factor + Reading Value.

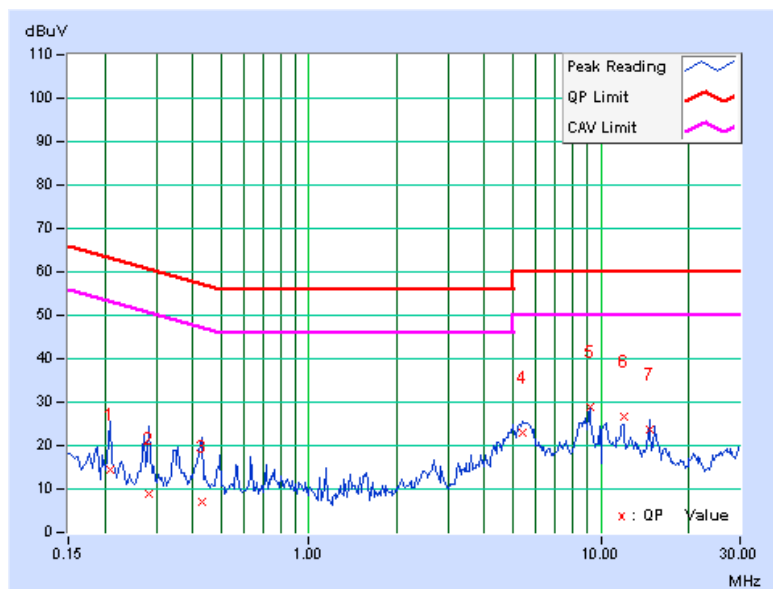

PHASE	Neutral (N)	6dB BANDWIDTH	9 kHz
--------------	-------------	----------------------	-------

No	Freq. [MHz]	Corr. Factor (dB)	Reading Value		Emission Level		Limit		Margin	
			[dB (uV)]		[dB (uV)]		[dB (uV)]		(dB)	
			Q.P.	AV.	Q.P.	AV.	Q.P.	AV.	Q.P.	AV.
1	0.177	0.08	12.73	-4.45	12.81	-4.37	64.61	54.61	-51.80	-58.98
2	0.248	0.09	7.54	-6.65	7.63	-6.56	61.84	51.84	-54.20	-58.39
3	0.322	0.10	7.54	-8.06	7.64	-7.96	59.66	49.66	-52.02	-57.62
4	5.035	0.27	21.25	14.89	21.52	15.16	60.00	50.00	-38.48	-34.84
5	9.219	0.39	24.96	20.35	25.35	20.74	60.00	50.00	-34.65	-29.26
6	10.410	0.42	25.56	22.51	25.98	22.93	60.00	50.00	-34.02	-27.07
7	11.945	0.46	26.41	22.05	26.87	22.51	60.00	50.00	-33.13	-27.49

- REMARKS:**
1. Q.P. and AV. are abbreviations of quasi-peak and average individually.
 2. The emission levels of other frequencies were very low against the limit.
 3. Margin value = Emission level - Limit value
 4. Correction factor = Insertion loss + Cable loss
 5. Emission Level = Correction Factor + Reading Value.

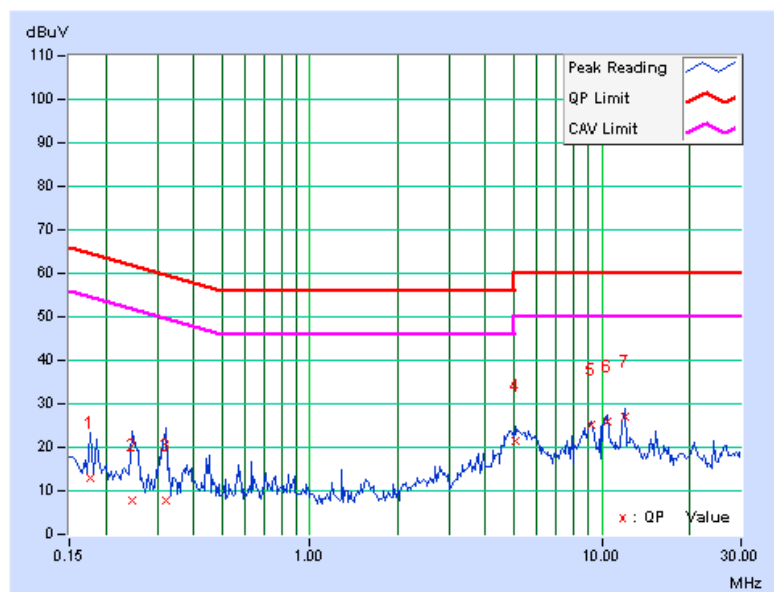

4.2 RADIATED EMISSION MEASUREMENT

4.2.1 LIMITS OF RADIATED EMISSION MEASUREMENT

Emissions radiated outside of the specified bands, shall be according to the general radiated limits in 15.209 as following:

Frequencies (MHz)	Field strength (microvolts/meter)	Measurement distance (meters)
0.009-0.490	2400/F(kHz)	300
0.490-1.705	24000/F(kHz)	30
1.705-30.0	30	30
30-88	100	3
88-216	150	3
216-960	200	3
Above 960	500	3

NOTE:

1. The lower limit shall apply at the transition frequencies.
2. Emission level (dBuV/m) = 20 log Emission level (uV/m).
3. As shown in 15.35(b), for frequencies above 1000MHz, the field strength limits are based on average detector, however, the peak field strength of any emission shall not exceed the maximum permitted average limits, specified above by more than 20dB under any condition of modulation.
4. Section 15.205 restricted bands of operation shall compliance with the limits in Section 15.209.



A D T

4.2.2 TEST INSTRUMENTS

For below 1GHz: Test date: Nov. 26, 2011

DESCRIPTION & MANUFACTURER	MODEL NO.	SERIAL NO.	CALIBRATED DATE	CALIBRATED UNTIL
Agilent Spectrum Analyzer	E4446A	MY48250253	Aug. 29, 2011	Aug. 28, 2012
Agilent Pre-Selector	N9039A	MY46520310	Aug. 29, 2011	Aug. 28, 2012
Agilent Signal Generator	N5181A	MY49060347	July 25, 2011	July 24, 2012
Mini-Circuits Pre-Amplifier	ZFL-1000VH2B	AMP-ZFL-04	Nov. 15, 2011	Nov. 14, 2012
Agilent Pre-Amplifier	8449B	3008A02465	Feb. 28, 2011	Feb. 27, 2012
SPACEK LABS	SLKKa-48-6	9K16	Nov. 15, 2011	Nov. 14, 2012
SCHWARZBECK Trilog Broadband Antenna	VULB 9168	9168-361	Apr. 14, 2011	Apr. 13, 2012
AISI Horn_Antenna	AIH.8018	0000220091110	Nov. 22, 2011	Nov. 21, 2012
SCHWARZBECK Horn_Antenna	BBHA 9170	9170-424	Oct. 07, 2011	Oct. 06, 2012
RF CABLE	NA	RF104-205 RF104-207 RF104-202	Dec. 28, 2010	Dec. 27, 2011
RF Cable	NA	CHHCAB_001	Oct. 08, 2011	Oct. 07, 2012
Software	ADT_Radiated_V8.7.05	NA	NA	NA
CT Antenna Tower & Turn Table	NA	NA	NA	NA

Note: 1. The calibration interval of the above test instruments is 12 months and the calibrations are traceable to NML/ROC and NIST/USA.

2. The horn antenna, preamplifier (model: 8449B) are used only for the measurement of emission frequency above 1GHz if tested.

3. The test was performed in 966 Chamber No. H.

4. The FCC Site Registration No. is 797305.

5. The CANADA Site Registration No. is IC 7450H-3.



A D T

For above 1GHz: Test date: Nov. 30, 2011

DESCRIPTION & MANUFACTURER	MODEL NO.	SERIAL NO.	CALIBRATED DATE	CALIBRATED UNTIL
Agilent Spectrum Analyzer	E4446A	MY48250254	July 12, 2011	July 11, 2012
Agilent Pre-Selector	N9039A	MY46520311	July 12, 2011	July 11, 2012
Agilent Signal Generator	N5181A	MY49060517	July 12, 2011	July 11, 2012
Mini-Circuits Pre-Amplifier	ZFL-1000VH2B	AMP-ZFL-03	Nov. 15, 2011	Nov. 14, 2012
Agilent Pre-Amplifier	8449B	3008A02578	July 04, 2011	July 03, 2012
SPACEK LABS	SLKKa-48-6	9K16	Nov. 15, 2011	Nov. 14, 2012
SCHWARZBECK Trilog Broadband Antenna	VULB 9168	9168-360	Apr. 14, 2011	Apr. 13, 2012
AISI Horn_Antenna	AIH.8018	0000320091110	Nov. 14, 2011	Nov. 13, 2012
SCHWARZBECK Horn_Antenna	BBHA 9170	9170-424	Oct. 07, 2011	Oct. 06, 2012
RF CABLE	NA	RF104-201 RF104-203 RF104-204	Dec. 27, 2010	Dec. 26, 2011
RF Cable	NA	CHGCAB_001	Oct. 07, 2011	Oct. 06, 2012
Software	ADT_Radiated_V8.7.05	NA	NA	NA
CT Antenna Tower & Turn Table	NA	NA	NA	NA

- Note: 1. The calibration interval of the above test instruments is 12 months and the calibrations are traceable to NML/ROC and NIST/USA.
2. The horn antenna, preamplifier (model: 8449B) are used only for the measurement of emission frequency above 1GHz if tested.
3. The test was performed in 966 Chamber No. G.
4. The FCC Site Registration No. is 966073.
5. The VCCI Site Registration No. is G-137.
6. The CANADA Site Registration No. is IC 7450H-2.

4.2.3 TEST PROCEDURES

- a. The EUT was placed on the top of a rotating table 0.8 meters above the ground at 3 meter chamber room. The table was rotated 360 degrees to determine the position of the highest radiation.
- b. The EUT was set 3 meters away from the interference-receiving antenna, which was mounted on the top of a variable-height antenna tower.
- c. The height of antenna is varied from one meter to four meters above the ground to determine the maximum value of the field strength. Both horizontal and vertical polarizations of the antenna are set to make the measurement.
- d. For each suspected emission, the EUT was arranged to its worst case and then the antenna was tuned to heights from 1 meter to 4 meters and the rotatable table was turned from 0 degrees to 360 degrees to find the maximum reading.
- e. The test-receiver system was set to quasi-peak detect function and specified bandwidth with maximum hold mode when the test frequency is below 1 GHz.
- f. The test-receiver system was set to peak and average detect function and specified bandwidth with maximum hold mode when the test frequency is above 1 GHz. If the peak reading value also meets average limit, measurement with the average detector is unnecessary.

NOTE:

1. The resolution bandwidth and video bandwidth of test receiver/spectrum analyzer is 120kHz for Quasi-peak detection (QP) at frequency below 1GHz.
2. The resolution bandwidth of test receiver/spectrum analyzer is 1 MHz and the video bandwidth is 3 MHz for Peak detection (PK) at frequency above 1GHz.
3. The resolution bandwidth of test receiver/spectrum analyzer is 1 MHz and the video bandwidth is 10 Hz for Average detection (AV) at frequency above 1GHz.

4.2.4 DEVIATION FROM TEST STANDARD

No deviation

4.2.5 TEST SETUP

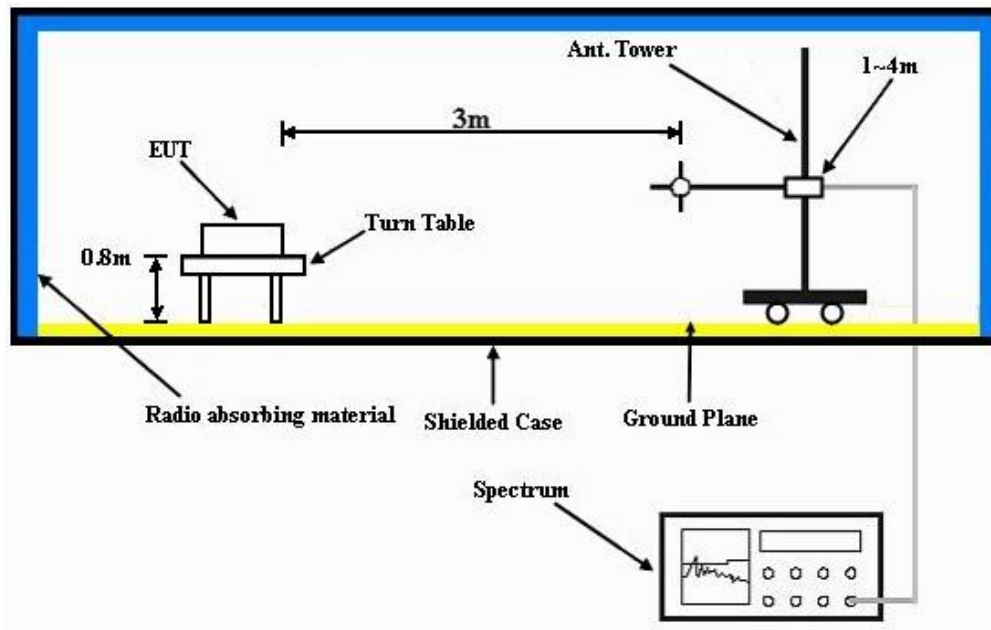

For the actual test configuration, please refer to the related item – Photographs of the Test Configuration.

4.2.6 EUT OPERATING CONDITIONS

Same as 4.1.6



A D T

4.2.7 TEST RESULTS

BELOW 1GHz WORST-CASE DATA : 802.11g OFDM MODULATION

EUT TEST CONDITION		MEASUREMENT DETAIL	
CHANNEL	Channel 6	FREQUENCY RANGE	Below 1000MHz
INPUT POWER	DC 3.3V	DETECTOR FUNCTION	Quasi-Peak
ENVIRONMENTAL CONDITIONS	18deg. C, 64%RH	TESTED BY	Nick Chang

ANTENNA POLARITY & TEST DISTANCE: HORIZONTAL AT 3 M								
NO.	FREQ. (MHz)	EMISSION LEVEL (dBuV/m)	LIMIT (dBuV/m)	MARGIN (dB)	ANTENNA HEIGHT (m)	TABLE ANGLE (Degree)	RAW VALUE (dBuV)	CORRECTION FACTOR (dB/m)
1	34.38	25.9 QP	40.0	-14.1	1.50 H	265	12.48	13.39
2	160.50	33.7 QP	43.5	-9.8	2.00 H	200	19.21	14.49
3	236.06	32.6 QP	46.0	-13.4	1.00 H	52	19.84	12.75
4	360.04	31.3 QP	46.0	-14.7	1.00 H	193	14.55	16.75
5	480.01	30.5 QP	46.0	-15.5	1.50 H	242	10.96	19.58
6	720.05	31.0 QP	46.0	-15.0	1.00 H	230	7.46	23.56
7	848.89	36.6 QP	46.0	-9.4	1.00 H	149	10.42	26.20
ANTENNA POLARITY & TEST DISTANCE: VERTICAL AT 3 M								
NO.	FREQ. (MHz)	EMISSION LEVEL (dBuV/m)	LIMIT (dBuV/m)	MARGIN (dB)	ANTENNA HEIGHT (m)	TABLE ANGLE (Degree)	RAW VALUE (dBuV)	CORRECTION FACTOR (dB/m)
1	46.11	27.3 QP	40.0	-12.7	1.00 V	136	12.94	14.33
2	148.30	29.9 QP	43.5	-13.6	1.00 V	307	15.29	14.59
3	360.16	29.2 QP	46.0	-16.8	1.00 V	122	12.48	16.75
4	480.01	26.3 QP	46.0	-19.8	1.00 V	287	6.67	19.58
5	747.29	29.7 QP	46.0	-16.3	1.50 V	237	5.55	24.19
6	848.66	33.3 QP	46.0	-12.7	1.50 V	286	7.09	26.20
7	946.35	31.2 QP	46.0	-14.8	1.00 V	225	3.59	27.62

- REMARKS:**
1. Emission level (dBuV/m) = Raw Value (dBuV) + Correction Factor (dB/m).
 2. Correction Factor (dB/m) = Antenna Factor (dB/m) + Cable Factor (dB).
 3. The other emission levels were very low against the limit.
 4. Margin value = Emission level – Limit value.



ABOVE 1GHz WORST-CASE DATA

802.11b DSSS MODULATION

EUT TEST CONDITION		MEASUREMENT DETAIL	
CHANNEL	Channel 1	FREQUENCY RANGE	1 ~ 25GHz
INPUT POWER	DC 3.3V	DETECTOR FUNCTION	Peak (PK) Average (AV)
ENVIRONMENTAL CONDITIONS	19deg. C, 66%RH	TESTED BY	Kent Liu

ANTENNA POLARITY & TEST DISTANCE: HORIZONTAL AT 3 M								
NO.	FREQ. (MHz)	EMISSION LEVEL (dBuV/m)	LIMIT (dBuV/m)	MARGIN (dB)	ANTENNA HEIGHT (m)	TABLE ANGLE (Degree)	RAW VALUE (dBuV)	CORRECTION FACTOR (dB/m)
1	2390.00	59.6 PK	74.0	-14.4	1.00 H	66	27.85	31.75
2	2390.00	49.9 AV	54.0	-4.1	1.00 H	66	18.15	31.75
3	*2412.00	106.9 PK			1.00 H	66	75.08	31.82
4	*2412.00	103.6 AV			1.00 H	66	71.78	31.82
5	4824.00	47.6 PK	74.0	-26.4	1.20 H	159	8.24	39.36
6	4824.00	35.5 AV	54.0	-18.5	1.20 H	159	-3.86	39.36
ANTENNA POLARITY & TEST DISTANCE: VERTICAL AT 3 M								
NO.	FREQ. (MHz)	EMISSION LEVEL (dBuV/m)	LIMIT (dBuV/m)	MARGIN (dB)	ANTENNA HEIGHT (m)	TABLE ANGLE (Degree)	RAW VALUE (dBuV)	CORRECTION FACTOR (dB/m)
1	2389.33	60.2 PK	74.0	-13.8	1.49 V	295	28.45	31.75
2	2389.33	52.4 AV	54.0	-1.6	1.49 V	295	20.65	31.75
3	*2412.00	111.4 PK			1.49 V	295	79.58	31.82
4	*2412.00	108.4 AV			1.49 V	295	76.58	31.82
5	4824.00	47.1 PK	74.0	-26.9	1.00 V	256	7.74	39.36
6	4824.00	38.2 AV	54.0	-15.8	1.00 V	256	-1.16	39.36

- REMARKS:**
1. Emission level (dBuV/m) = Raw Value (dBuV) + Correction Factor (dB/m).
 2. Correction Factor (dB/m) = Antenna Factor (dB/m) + Cable Factor (dB).
 3. The other emission levels were very low against the limit.
 4. Margin value = Emission level – Limit value.
 5. “ * “: Fundamental frequency.



A D T

EUT TEST CONDITION		MEASUREMENT DETAIL	
CHANNEL	Channel 2	FREQUENCY RANGE	1 ~ 25GHz
INPUT POWER	DC 3.3V	DETECTOR FUNCTION	Peak (PK) Average (AV)
ENVIRONMENTAL CONDITIONS	19deg. C, 66%RH	TESTED BY	Kent Liu

ANTENNA POLARITY & TEST DISTANCE: HORIZONTAL AT 3 M

NO.	FREQ. (MHz)	EMISSION LEVEL (dBuV/m)	LIMIT (dBuV/m)	MARGIN (dB)	ANTENNA HEIGHT (m)	TABLE ANGLE (Degree)	RAW VALUE (dBuV)	CORRECTION FACTOR (dB/m)
1	2390.00	59.3 PK	74.0	-14.7	1.02 H	67	27.55	31.75
2	2390.00	51.0 AV	54.0	-3.0	1.02 H	67	19.25	31.75
3	*2417.00	107.3 PK			1.02 H	67	75.46	31.84
4	*2417.00	103.5 AV			1.02 H	67	71.66	31.84
5	4834.00	47.7 PK	74.0	-26.3	1.24 H	173	8.31	39.39
6	4834.00	35.3 AV	54.0	-18.7	1.24 H	173	-4.09	39.39
7	7251.00	54.8 PK	74.0	-19.2	1.63 H	241	7.88	46.92
8	7251.00	43.1 AV	54.0	-10.9	1.63 H	241	-3.82	46.92

ANTENNA POLARITY & TEST DISTANCE: VERTICAL AT 3 M

NO.	FREQ. (MHz)	EMISSION LEVEL (dBuV/m)	LIMIT (dBuV/m)	MARGIN (dB)	ANTENNA HEIGHT (m)	TABLE ANGLE (Degree)	RAW VALUE (dBuV)	CORRECTION FACTOR (dB/m)
1	2386.13	61.0 PK	74.0	-13.0	1.54 V	295	29.26	31.74
2	2386.13	52.6 AV	54.0	-1.4	1.54 V	295	20.86	31.74
3	*2417.00	112.8 PK			1.54 V	295	80.96	31.84
4	*2417.00	109.8 AV			1.54 V	295	77.96	31.84
5	4834.00	46.6 PK	74.0	-27.4	1.00 V	274	7.21	39.39
6	4834.00	37.9 AV	54.0	-16.1	1.00 V	274	-1.49	39.39
7	7251.00	52.8 PK	74.0	-21.2	1.75 V	200	5.88	46.92
8	7251.00	43.0 AV	54.0	-11.0	1.75 V	200	-3.92	46.92

- REMARKS:**
1. Emission level (dBuV/m) = Raw Value (dBuV) + Correction Factor (dB/m).
 2. Correction Factor (dB/m) = Antenna Factor (dB/m) + Cable Factor (dB).
 3. The other emission levels were very low against the limit.
 4. Margin value = Emission level – Limit value.
 5. “ * “: Fundamental frequency.



A D T

EUT TEST CONDITION		MEASUREMENT DETAIL	
CHANNEL	Channel 6	FREQUENCY RANGE	1 ~ 25GHz
INPUT POWER	DC 3.3V	DETECTOR FUNCTION	Peak (PK) Average (AV)
ENVIRONMENTAL CONDITIONS	19deg. C, 66%RH	TESTED BY	Kent Liu

ANTENNA POLARITY & TEST DISTANCE: HORIZONTAL AT 3 M								
NO.	FREQ. (MHz)	EMISSION LEVEL (dBuV/m)	LIMIT (dBuV/m)	MARGIN (dB)	ANTENNA HEIGHT (m)	TABLE ANGLE (Degree)	RAW VALUE (dBuV)	CORRECTION FACTOR (dB/m)
1	*2437.00	107.7 PK			1.03 H	64	75.78	31.92
2	*2437.00	103.7 AV			1.03 H	64	71.78	31.92
3	4874.00	48.0 PK	74.0	-26.0	1.22 H	168	8.50	39.50
4	4874.00	35.6 AV	54.0	-18.4	1.22 H	168	-3.90	39.50
5	7311.00	54.9 PK	74.0	-19.1	1.62 H	239	8.02	46.88
6	7311.00	43.3 AV	54.0	-10.7	1.62 H	239	-3.58	46.88
ANTENNA POLARITY & TEST DISTANCE: VERTICAL AT 3 M								
NO.	FREQ. (MHz)	EMISSION LEVEL (dBuV/m)	LIMIT (dBuV/m)	MARGIN (dB)	ANTENNA HEIGHT (m)	TABLE ANGLE (Degree)	RAW VALUE (dBuV)	CORRECTION FACTOR (dB/m)
1	*2437.00	113.4 PK			1.48 V	296	81.48	31.92
2	*2437.00	110.3 AV			1.48 V	296	78.38	31.92
3	4874.00	47.2 PK	74.0	-26.8	1.00 V	266	7.70	39.50
4	4874.00	38.3 AV	54.0	-15.7	1.00 V	266	-1.20	39.50
5	7311.00	53.0 PK	74.0	-21.0	1.76 V	200	6.12	46.88
6	7311.00	43.2 AV	54.0	-10.8	1.76 V	200	-3.68	46.88

- REMARKS:**
1. Emission level (dBuV/m) = Raw Value (dBuV) + Correction Factor (dB/m).
 2. Correction Factor (dB/m) = Antenna Factor (dB/m) + Cable Factor (dB).
 3. The other emission levels were very low against the limit.
 4. Margin value = Emission level – Limit value.
 5. “ * “: Fundamental frequency.



A D T

EUT TEST CONDITION		MEASUREMENT DETAIL	
CHANNEL	Channel 10	FREQUENCY RANGE	1 ~ 25GHz
INPUT POWER	DC 3.3V	DETECTOR FUNCTION	Peak (PK) Average (AV)
ENVIRONMENTAL CONDITIONS	19deg. C, 66%RH	TESTED BY	Kent Liu

ANTENNA POLARITY & TEST DISTANCE: HORIZONTAL AT 3 M								
NO.	FREQ. (MHz)	EMISSION LEVEL (dBuV/m)	LIMIT (dBuV/m)	MARGIN (dB)	ANTENNA HEIGHT (m)	TABLE ANGLE (Degree)	RAW VALUE (dBuV)	CORRECTION FACTOR (dB/m)
1	*2457.00	107.7 PK			1.00 H	67	75.71	31.99
2	*2457.00	103.7 AV			1.00 H	67	71.71	31.99
3	2485.30	58.5 PK	74.0	-15.5	1.00 H	67	26.40	32.10
4	2485.30	48.4 AV	54.0	-5.6	1.00 H	67	16.30	32.10
5	4914.00	47.8 PK	74.0	-26.2	1.25 H	169	8.17	39.63
6	4914.00	35.4 AV	54.0	-18.6	1.25 H	169	-4.23	39.63
7	7371.00	54.4 PK	74.0	-19.6	1.60 H	253	7.59	46.81
8	7371.00	43.0 AV	54.0	-11.0	1.60 H	253	-3.81	46.81
ANTENNA POLARITY & TEST DISTANCE: VERTICAL AT 3 M								
NO.	FREQ. (MHz)	EMISSION LEVEL (dBuV/m)	LIMIT (dBuV/m)	MARGIN (dB)	ANTENNA HEIGHT (m)	TABLE ANGLE (Degree)	RAW VALUE (dBuV)	CORRECTION FACTOR (dB/m)
1	*2457.00	112.5 PK			1.57 V	298	80.51	31.99
2	*2457.00	109.6 AV			1.57 V	298	77.61	31.99
3	2485.10	61.0 PK	74.0	-13.0	1.47 V	298	28.91	32.09
4	2485.10	51.3 AV	54.0	-2.7	1.47 V	298	19.21	32.09
5	4914.00	47.2 PK	74.0	-26.8	1.00 V	264	7.57	39.63
6	4914.00	38.3 AV	54.0	-15.7	1.00 V	264	-1.33	39.63
7	7371.00	53.3 PK	74.0	-20.7	1.73 V	201	6.49	46.81
8	7371.00	43.6 AV	54.0	-10.4	1.73 V	201	-3.21	46.81

- REMARKS:**
1. Emission level (dBuV/m) = Raw Value (dBuV) + Correction Factor (dB/m).
 2. Correction Factor (dB/m) = Antenna Factor (dB/m) + Cable Factor (dB).
 3. The other emission levels were very low against the limit.
 4. Margin value = Emission level – Limit value.
 5. “ * “: Fundamental frequency.



A D T

EUT TEST CONDITION		MEASUREMENT DETAIL	
CHANNEL	Channel 11	FREQUENCY RANGE	1 ~ 25GHz
INPUT POWER	DC 3.3V	DETECTOR FUNCTION	Peak (PK) Average (AV)
ENVIRONMENTAL CONDITIONS	19deg. C, 66%RH	TESTED BY	Kent Liu

ANTENNA POLARITY & TEST DISTANCE: HORIZONTAL AT 3 M

NO.	FREQ. (MHz)	EMISSION LEVEL (dBuV/m)	LIMIT (dBuV/m)	MARGIN (dB)	ANTENNA HEIGHT (m)	TABLE ANGLE (Degree)	RAW VALUE (dBuV)	CORRECTION FACTOR (dB/m)
1	*2462.00	105.9 PK			1.48 H	249	73.89	32.01
2	*2462.00	103.0 AV			1.48 H	249	70.99	32.01
3	2483.50	56.5 PK	74.0	-17.5	1.48 H	249	24.41	32.09
4	2483.50	45.9 AV	54.0	-8.1	1.48 H	249	13.81	32.09
5	4924.00	47.8 PK	74.0	-26.2	1.18 H	175	8.13	39.67
6	4924.00	35.5 AV	54.0	-18.5	1.18 H	175	-4.17	39.67
7	7386.00	54.7 PK	74.0	-19.3	1.62 H	224	7.90	46.80
8	7386.00	43.1 AV	54.0	-10.9	1.62 H	224	-3.70	46.80

ANTENNA POLARITY & TEST DISTANCE: VERTICAL AT 3 M

NO.	FREQ. (MHz)	EMISSION LEVEL (dBuV/m)	LIMIT (dBuV/m)	MARGIN (dB)	ANTENNA HEIGHT (m)	TABLE ANGLE (Degree)	RAW VALUE (dBuV)	CORRECTION FACTOR (dB/m)
1	*2462.00	112.3 PK			1.48 V	295	80.29	32.01
2	*2462.00	109.3 AV			1.48 V	295	77.29	32.01
3	2483.50	60.8 PK	74.0	-13.2	1.48 V	295	28.71	32.09
4	2483.50	52.4 AV	54.0	-1.6	1.48 V	295	20.31	32.09
5	4924.00	47.9 PK	74.0	-26.1	1.00 V	256	8.23	39.67
6	4924.00	38.8 AV	54.0	-15.2	1.00 V	256	-0.87	39.67
7	7386.00	53.2 PK	74.0	-20.8	1.73 V	202	6.40	46.80
8	7386.00	43.5 AV	54.0	-10.5	1.73 V	202	-3.30	46.80

- REMARKS:**
1. Emission level (dBuV/m) = Raw Value (dBuV) + Correction Factor (dB/m).
 2. Correction Factor (dB/m) = Antenna Factor (dB/m) + Cable Factor (dB).
 3. The other emission levels were very low against the limit.
 4. Margin value = Emission level – Limit value.
 5. “ * “: Fundamental frequency.



A D T

EUT TEST CONDITION		MEASUREMENT DETAIL	
CHANNEL	Channel 12	FREQUENCY RANGE	1 ~ 25GHz
INPUT POWER	DC 3.3V	DETECTOR FUNCTION	Peak (PK) Average (AV)
ENVIRONMENTAL CONDITIONS	19deg. C, 66%RH	TESTED BY	Kent Liu

ANTENNA POLARITY & TEST DISTANCE: HORIZONTAL AT 3 M

NO.	FREQ. (MHz)	EMISSION LEVEL (dBuV/m)	LIMIT (dBuV/m)	MARGIN (dB)	ANTENNA HEIGHT (m)	TABLE ANGLE (Degree)	RAW VALUE (dBuV)	CORRECTION FACTOR (dB/m)
1	*2467.00	102.5 PK			1.01 H	67	70.47	32.03
2	*2467.00	98.8 AV			1.01 H	67	66.77	32.03
3	2484.20	58.6 PK	74.0	-15.4	1.01 H	67	26.51	32.09
4	2484.20	47.6 AV	54.0	-6.4	1.01 H	67	15.51	32.09
5	4934.00	44.7 PK	74.0	-29.3	1.23 H	175	4.99	39.71
6	4934.00	34.1 AV	54.0	-19.9	1.23 H	175	-5.61	39.71
7	7401.00	52.5 PK	74.0	-21.5	1.65 H	228	5.72	46.78
8	7401.00	41.2 AV	54.0	-12.8	1.65 H	228	-5.58	46.78

ANTENNA POLARITY & TEST DISTANCE: VERTICAL AT 3 M

NO.	FREQ. (MHz)	EMISSION LEVEL (dBuV/m)	LIMIT (dBuV/m)	MARGIN (dB)	ANTENNA HEIGHT (m)	TABLE ANGLE (Degree)	RAW VALUE (dBuV)	CORRECTION FACTOR (dB/m)
1	*2467.00	108.2 PK			1.46 V	294	76.17	32.03
2	*2467.00	105.3 AV			1.46 V	294	73.27	32.03
3	2484.35	61.0 PK	74.0	-13.0	1.46 V	294	28.91	32.09
4	2484.35	52.8 AV	54.0	-1.2	1.46 V	294	20.71	32.09
5	4934.00	47.8 PK	74.0	-26.2	1.05 V	269	8.09	39.71
6	4934.00	38.5 AV	54.0	-15.5	1.05 V	269	-1.21	39.71
7	7401.00	53.6 PK	74.0	-20.4	1.68 V	217	6.82	46.78
8	7401.00	43.6 AV	54.0	-10.4	1.68 V	217	-3.18	46.78

- REMARKS:**
1. Emission level (dBuV/m) = Raw Value (dBuV) + Correction Factor (dB/m).
 2. Correction Factor (dB/m) = Antenna Factor (dB/m) + Cable Factor (dB).
 3. The other emission levels were very low against the limit.
 4. Margin value = Emission level – Limit value.
 5. “ * “: Fundamental frequency.



A D T

EUT TEST CONDITION		MEASUREMENT DETAIL	
CHANNEL	Channel 13	FREQUENCY RANGE	1 ~ 25GHz
INPUT POWER	DC 3.3V	DETECTOR FUNCTION	Peak (PK) Average (AV)
ENVIRONMENTAL CONDITIONS	19deg. C, 66%RH	TESTED BY	Kent Liu

ANTENNA POLARITY & TEST DISTANCE: HORIZONTAL AT 3 M

NO.	FREQ. (MHz)	EMISSION LEVEL (dBuV/m)	LIMIT (dBuV/m)	MARGIN (dB)	ANTENNA HEIGHT (m)	TABLE ANGLE (Degree)	RAW VALUE (dBuV)	CORRECTION FACTOR (dB/m)
1	*2472.00	98.6 PK			1.02 H	70	66.55	32.05
2	*2472.00	95.0 AV			1.02 H	70	62.95	32.05
3	2486.25	57.9 PK	74.0	-16.1	1.00 H	68	25.80	32.10
4	2486.25	47.1 AV	54.0	-6.9	1.00 H	68	15.00	32.10
5	4944.00	45.8 PK	74.0	-28.2	1.20 H	162	6.05	39.75
6	4944.00	33.5 AV	54.0	-20.5	1.20 H	162	-6.25	39.75
7	7416.00	52.4 PK	74.0	-21.6	1.60 H	214	5.63	46.77
8	7416.00	40.4 AV	54.0	-13.6	1.60 H	214	-6.37	46.77

ANTENNA POLARITY & TEST DISTANCE: VERTICAL AT 3 M

NO.	FREQ. (MHz)	EMISSION LEVEL (dBuV/m)	LIMIT (dBuV/m)	MARGIN (dB)	ANTENNA HEIGHT (m)	TABLE ANGLE (Degree)	RAW VALUE (dBuV)	CORRECTION FACTOR (dB/m)
1	*2472.00	104.5 PK			1.46 V	293	72.45	32.05
2	*2472.00	101.4 AV			1.46 V	293	69.35	32.05
3	2486.77	60.4 PK	74.0	-13.6	1.45 V	298	28.30	32.10
4	2486.77	52.9 AV	54.0	-1.1	1.45 V	298	20.80	32.10
5	4944.00	47.4 PK	74.0	-26.6	1.00 V	243	7.65	39.75
6	4944.00	38.6 AV	54.0	-15.4	1.00 V	243	-1.15	39.75
7	7416.00	52.9 PK	74.0	-21.1	1.70 V	201	6.13	46.77
8	7416.00	43.2 AV	54.0	-10.8	1.70 V	201	-3.57	46.77

- REMARKS:**
1. Emission level (dBuV/m) = Raw Value (dBuV) + Correction Factor (dB/m).
 2. Correction Factor (dB/m) = Antenna Factor (dB/m) + Cable Factor (dB).
 3. The other emission levels were very low against the limit.
 4. Margin value = Emission level – Limit value.
 5. “ * “: Fundamental frequency.



A D T

RESTRICTED BANDEDGE (802.11b MODE, CH1, HORIZONTAL)

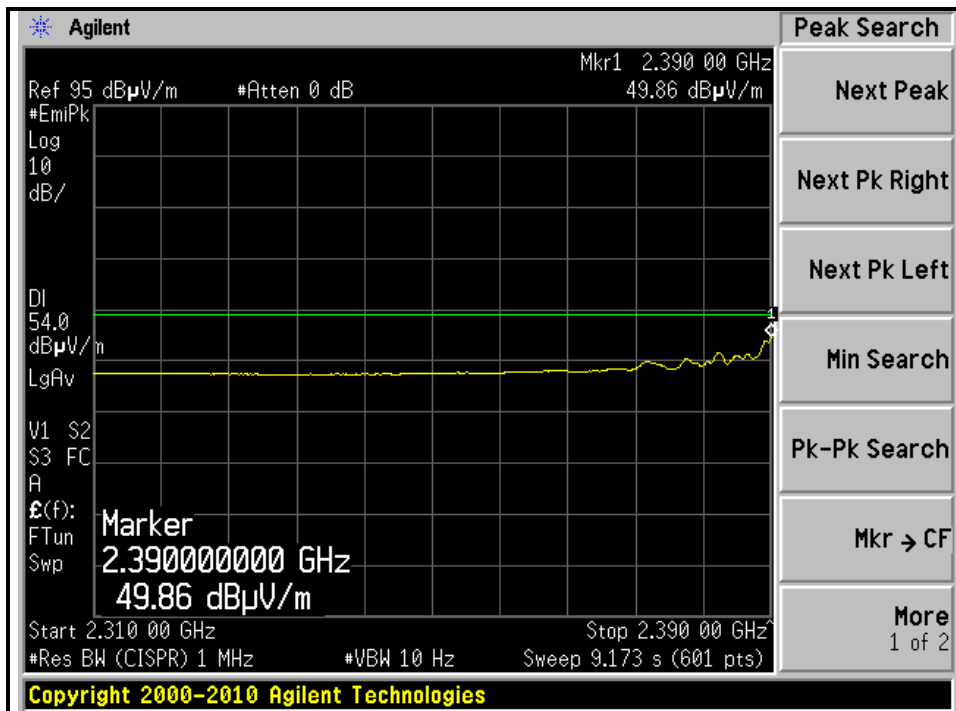
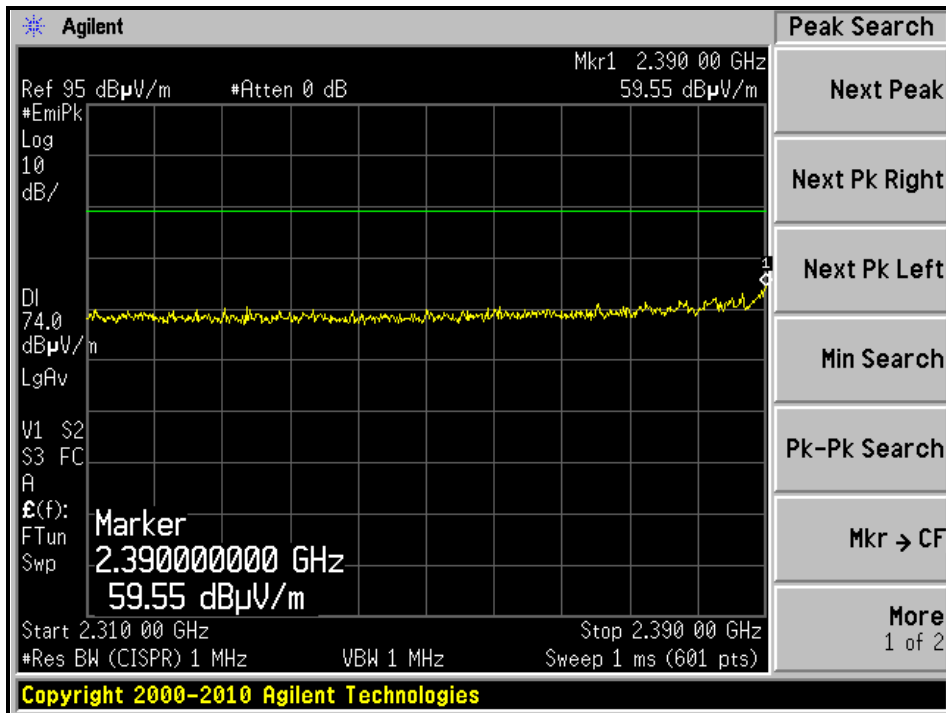

RESTRICTED BANDEDGE (802.11b MODE, CH1, VERTICAL)

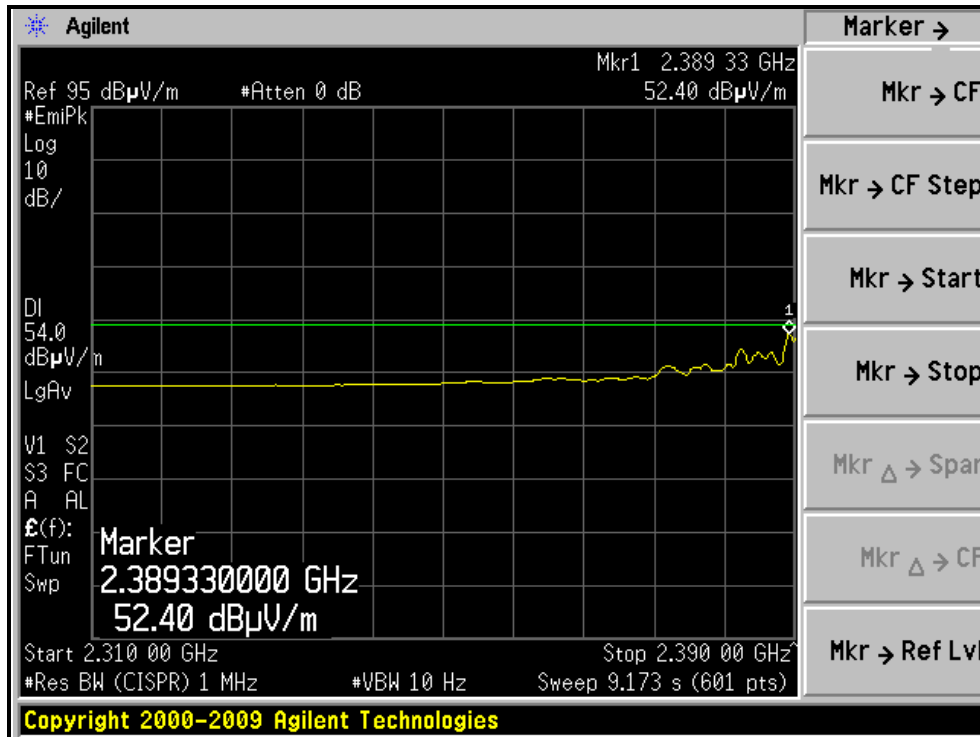
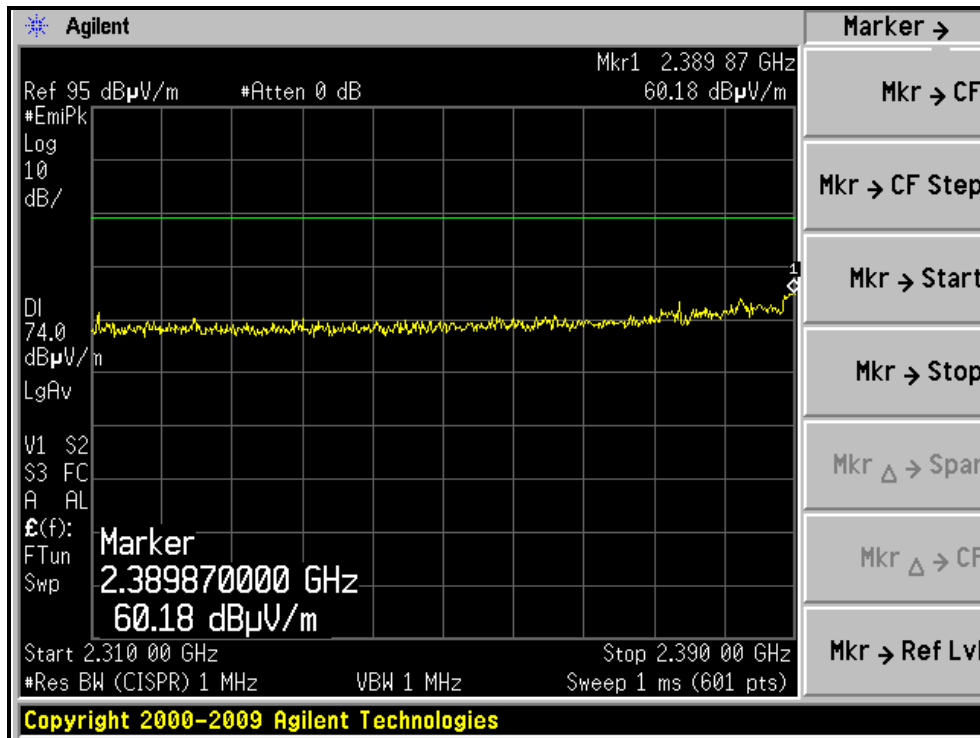

RESTRICTED BANDEDGE (802.11b MODE, CH2, HORIZONTAL)

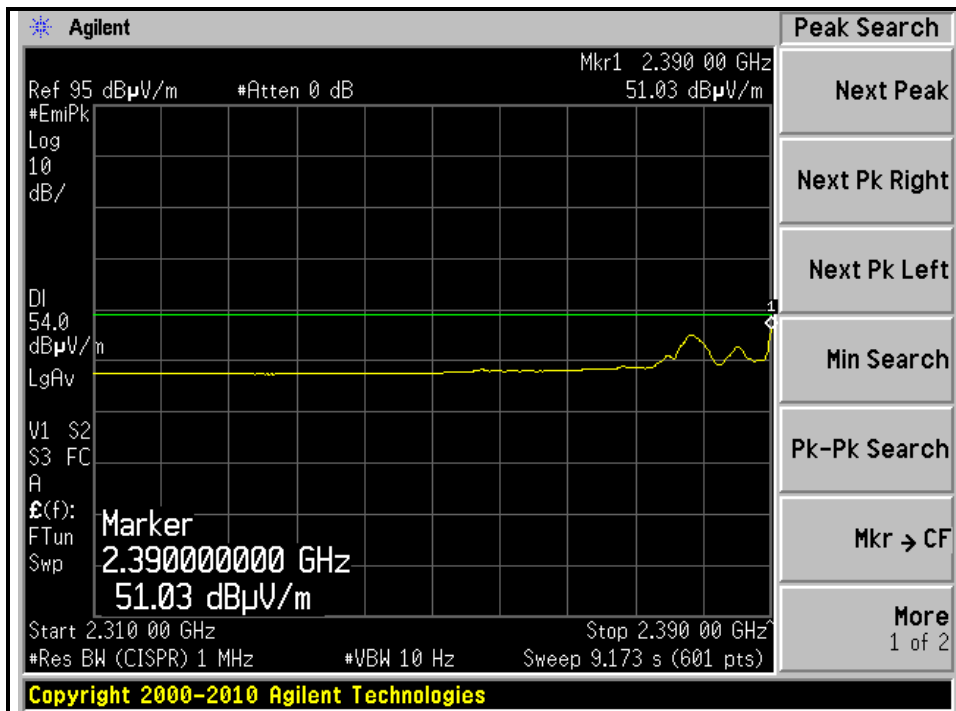
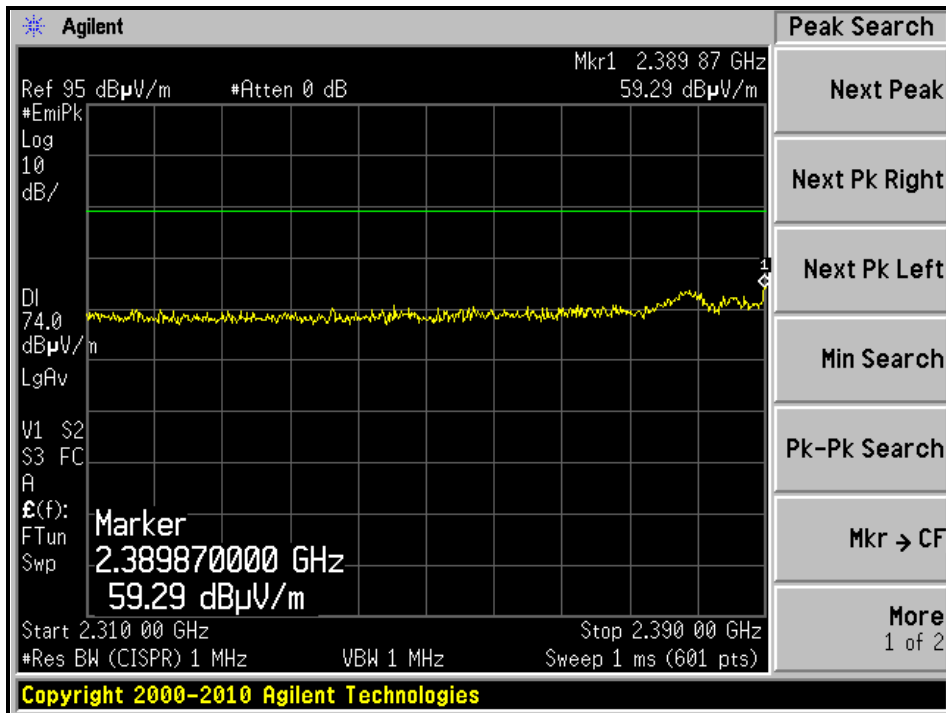

RESTRICTED BANDEDGE (802.11b MODE, CH2, VERTICAL)

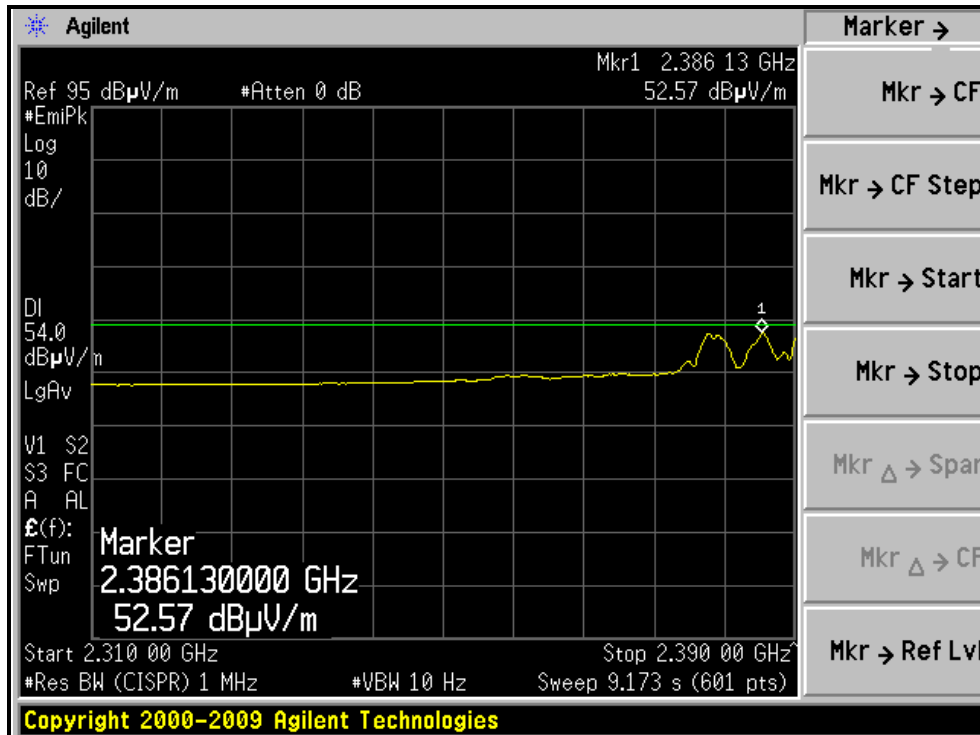
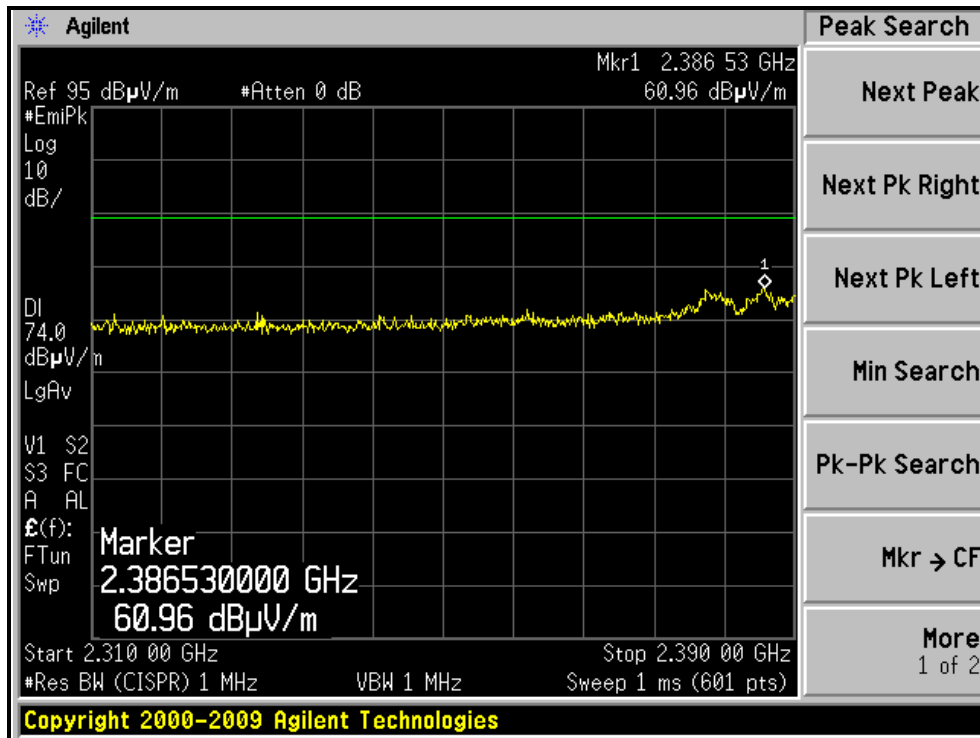

RESTRICTED BANDEDGE (802.11b MODE, CH10, HORIZONTAL)

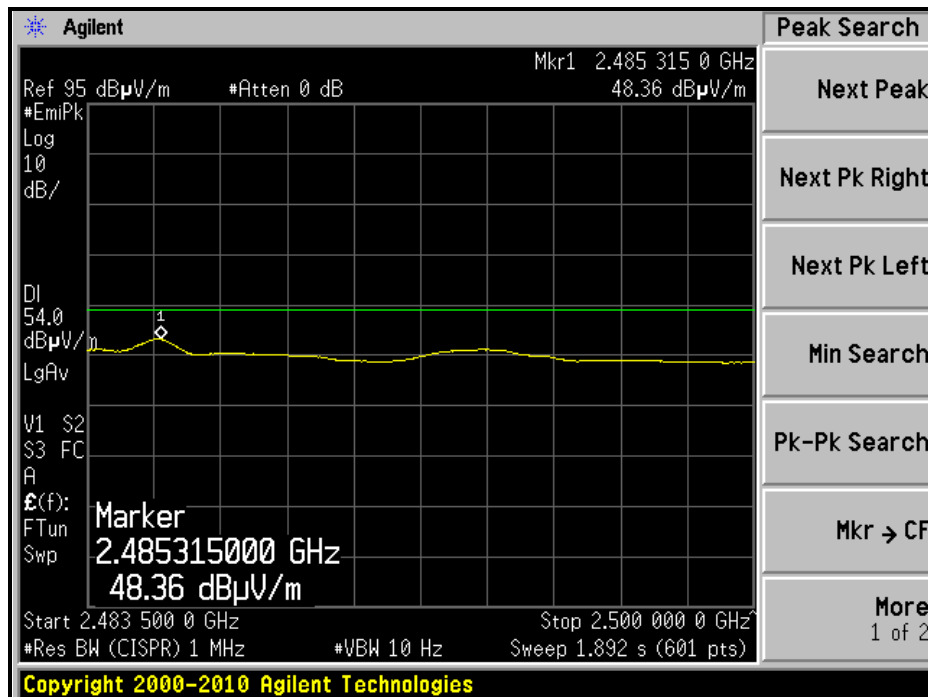
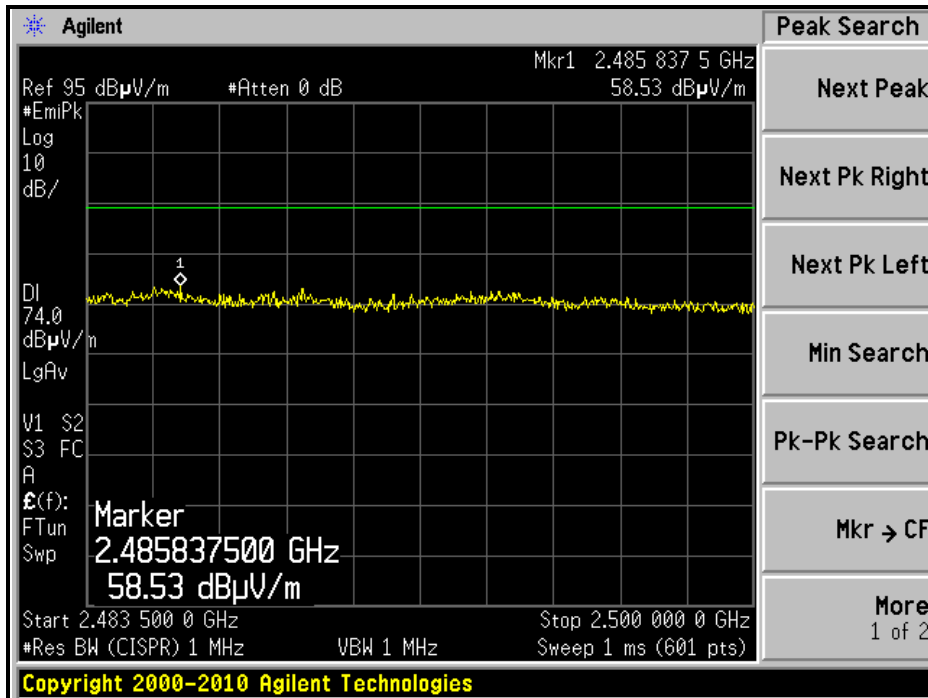

RESTRICTED BANDEDGE (802.11b MODE, CH10, VERTICAL)

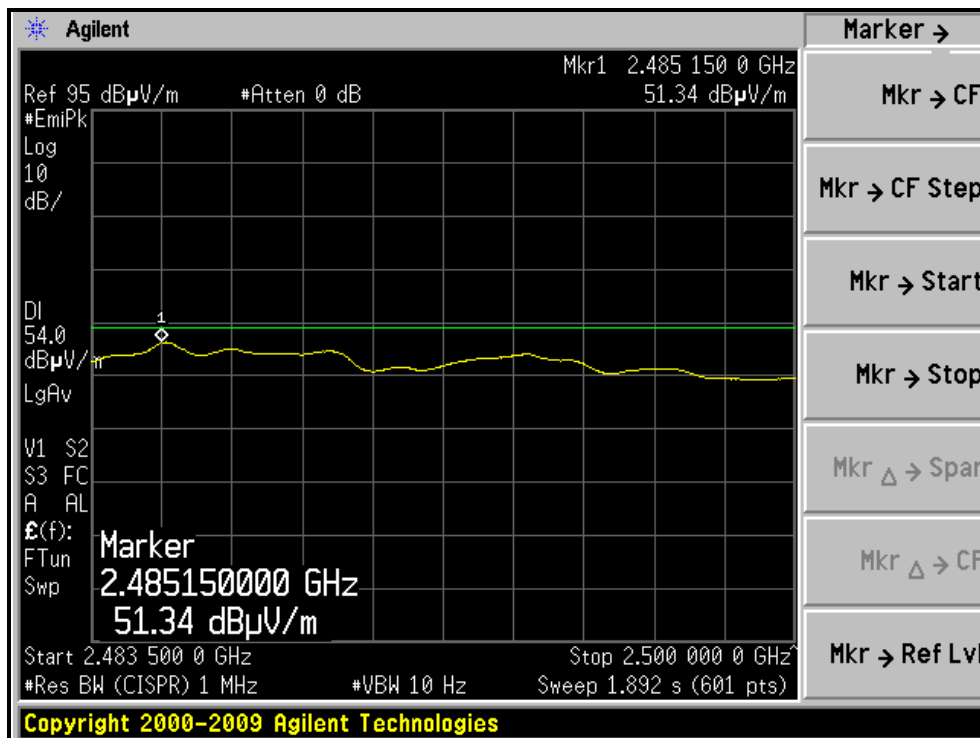
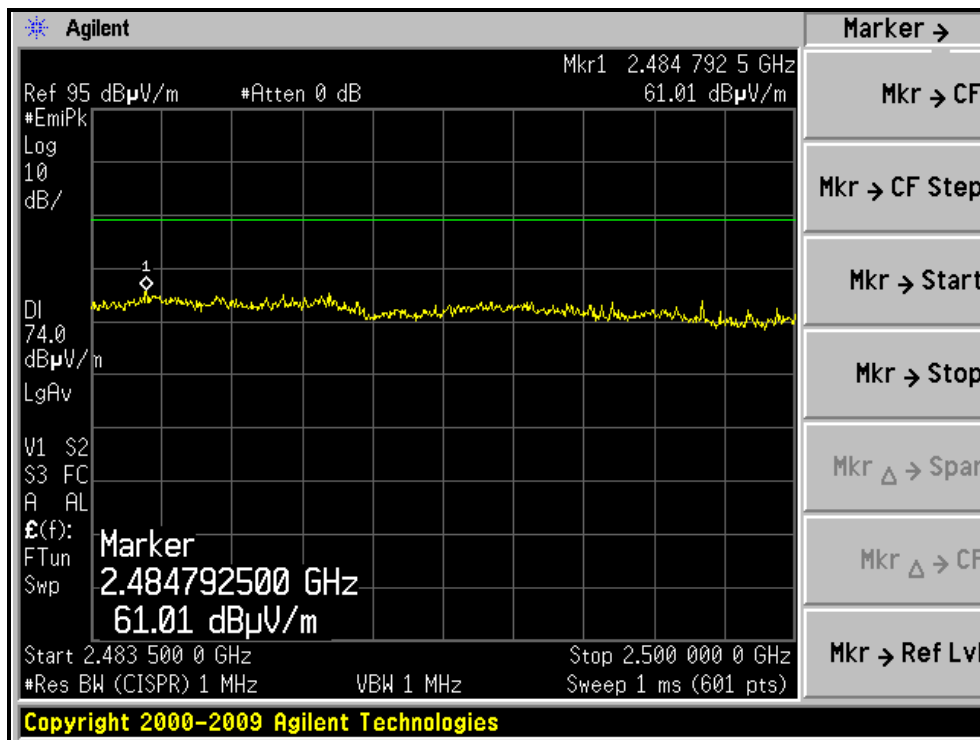

RESTRICTED BANDEDGE (802.11b MODE, CH11, HORIZONTAL)

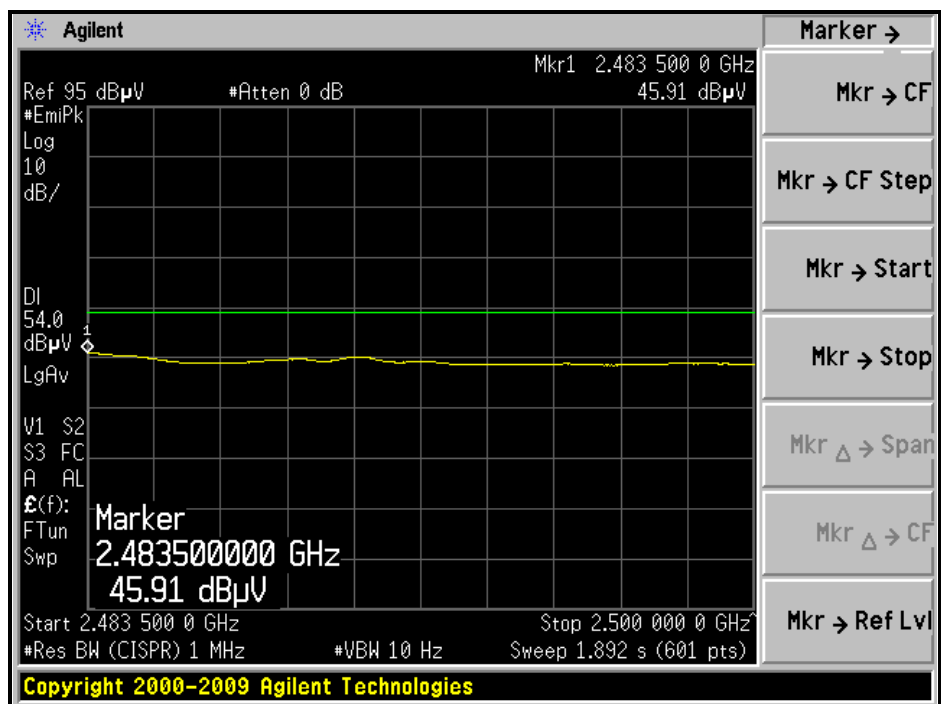
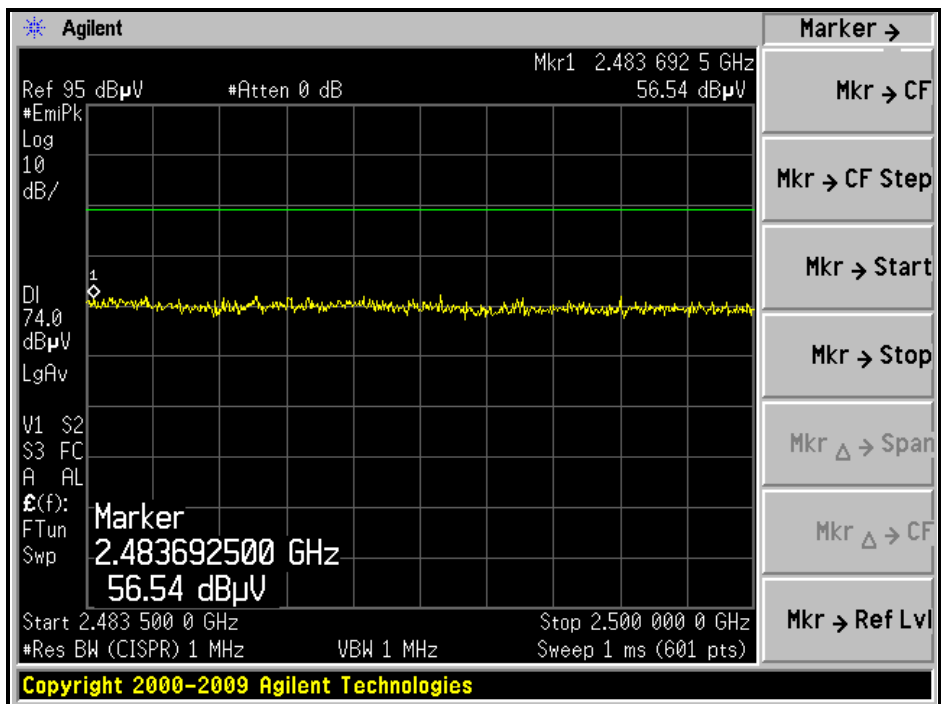

RESTRICTED BANDEDGE (802.11b MODE, CH11, VERTICAL)

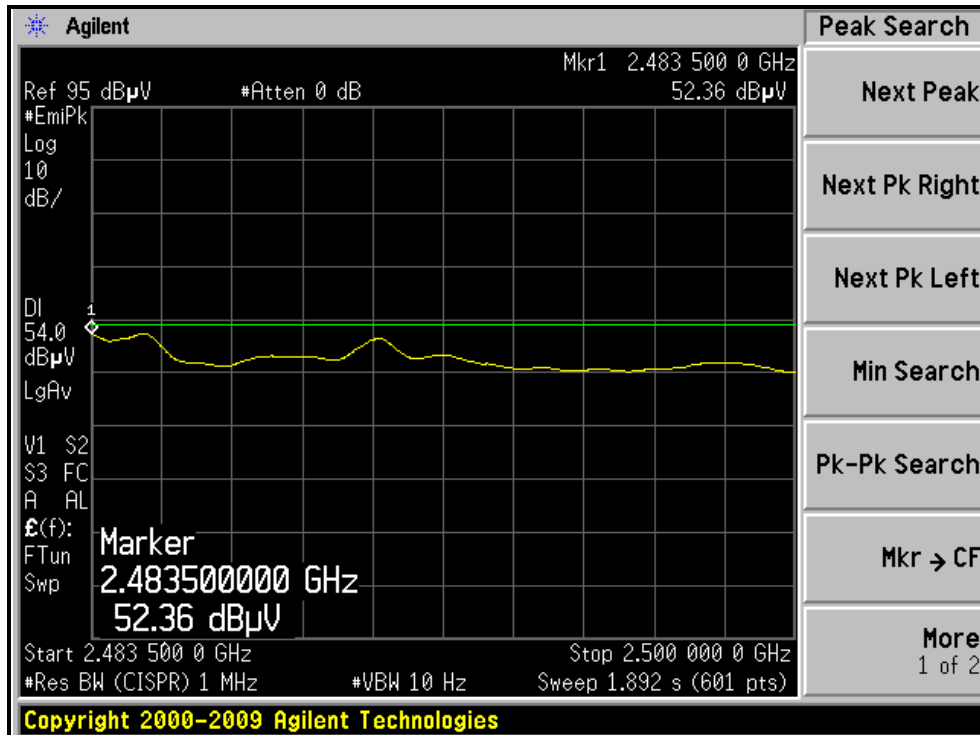
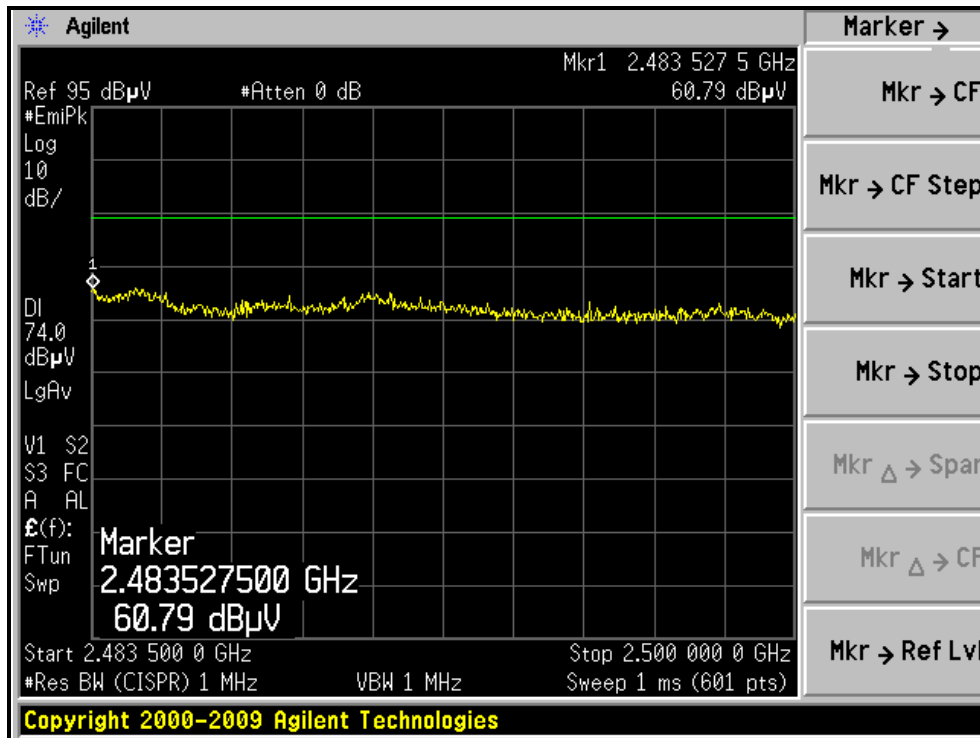

RESTRICTED BANDEDGE (802.11b MODE, CH12, HORIZONTAL)

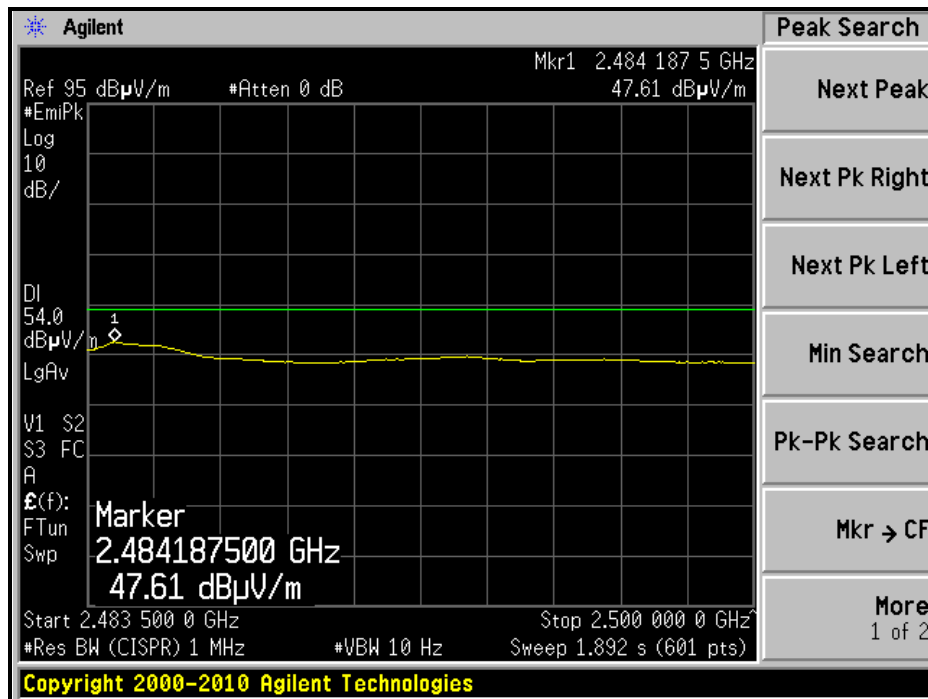
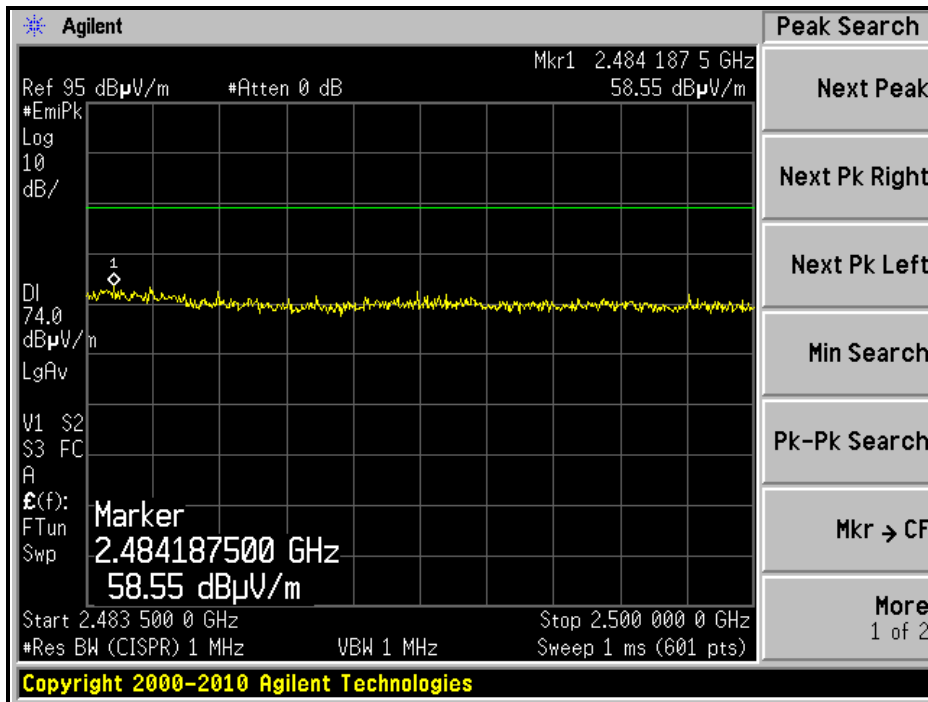

RESTRICTED BANDEDGE (802.11b MODE, CH12, VERTICAL)

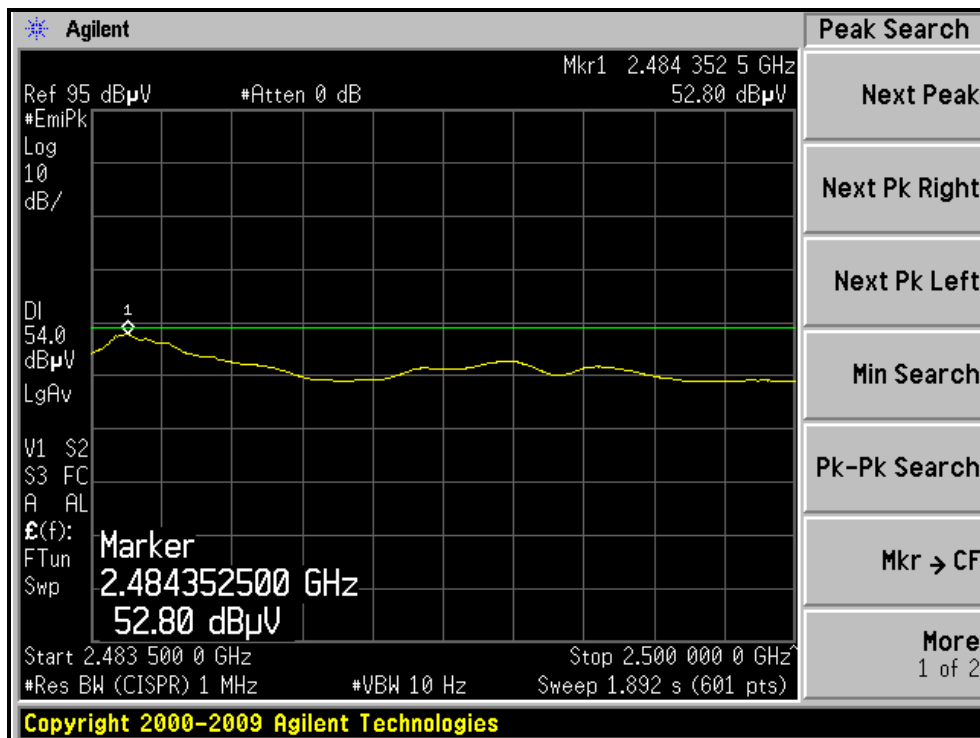
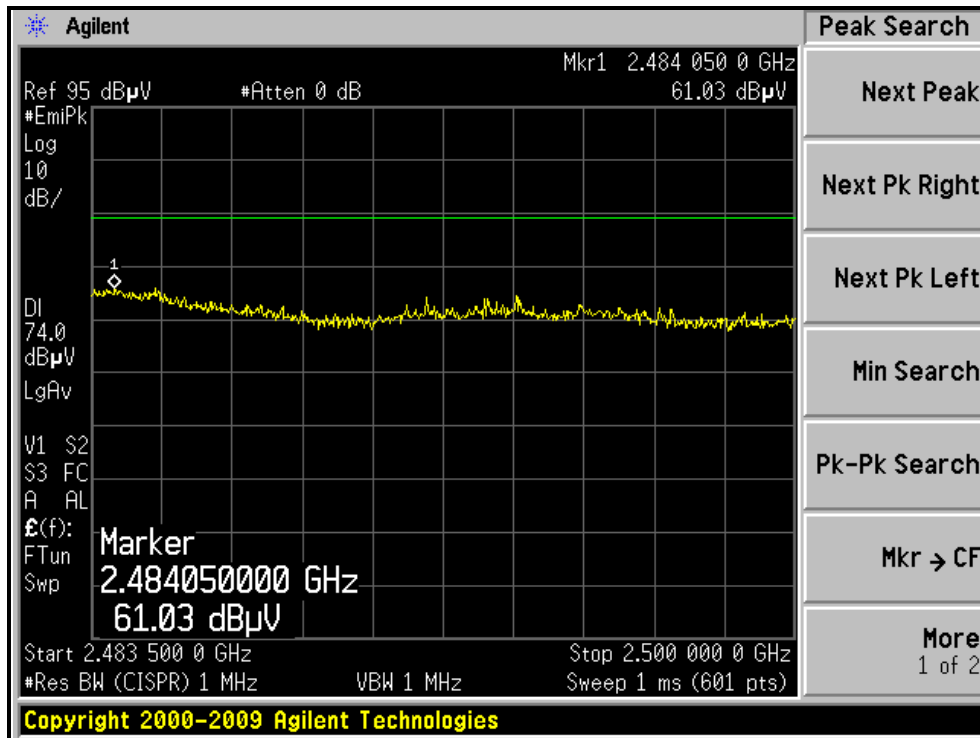

RESTRICTED BANDEDGE (802.11b MODE, CH13, HORIZONTAL)

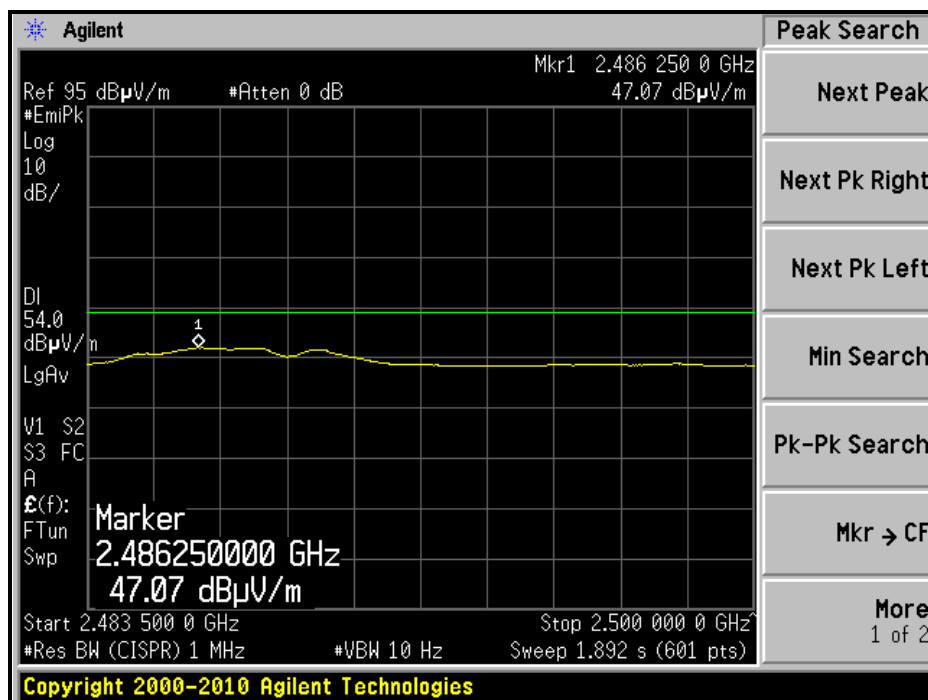
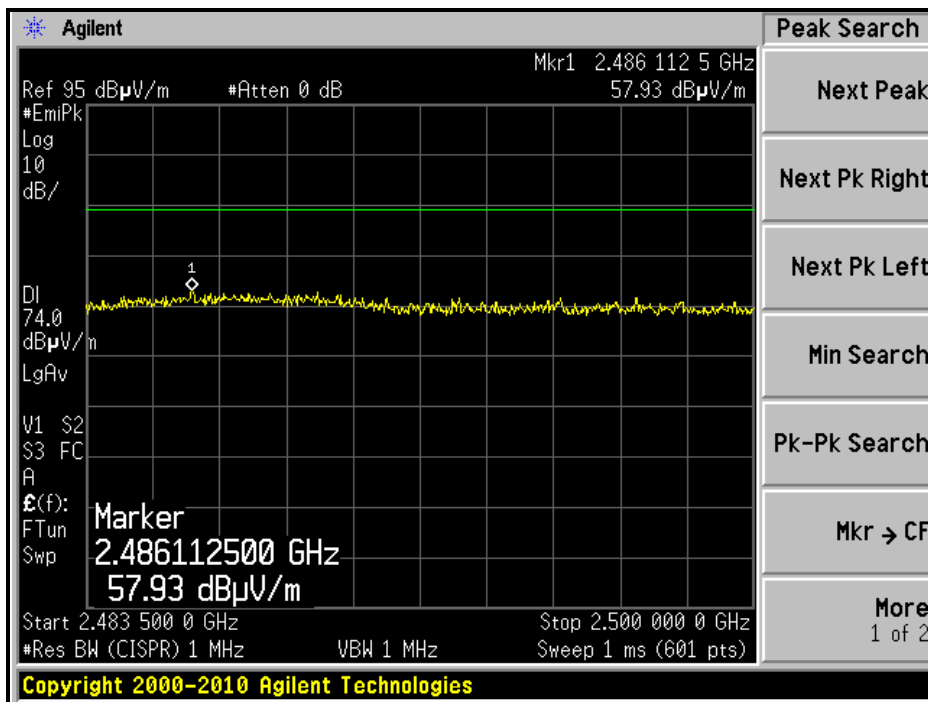

RESTRICTED BANDEDGE (802.11b MODE, CH13, VERTICAL)

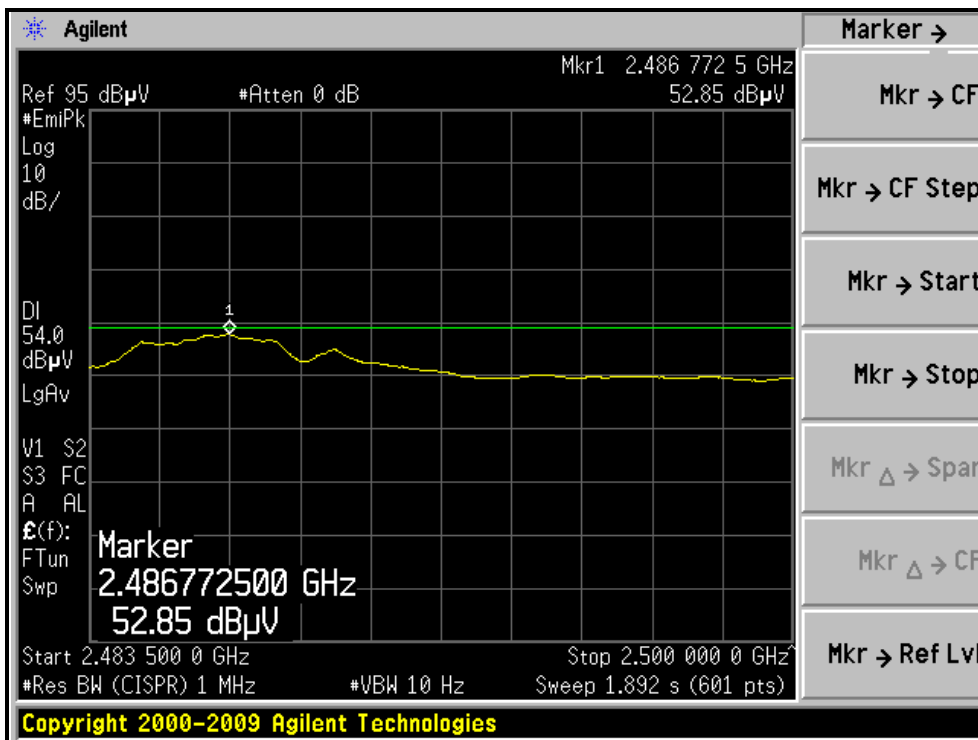
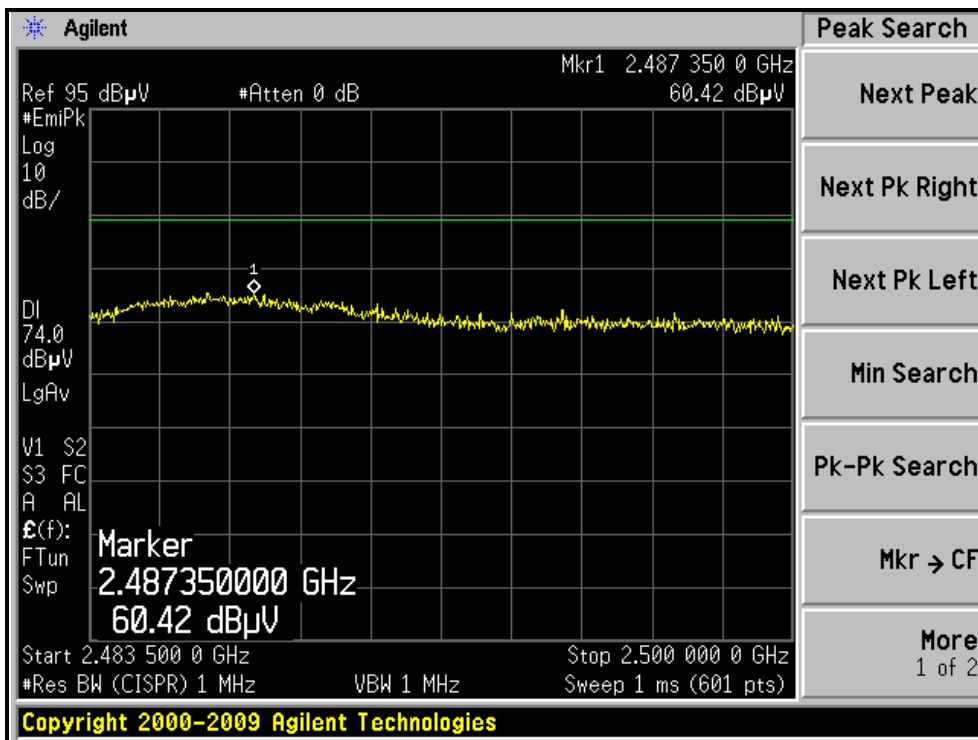



802.11g OFDM MODULATION

EUT TEST CONDITION		MEASUREMENT DETAIL	
CHANNEL	Channel 1	FREQUENCY RANGE	1 ~ 25GHz
INPUT POWER	DC 3.3V	DETECTOR FUNCTION	Peak (PK) Average (AV)
ENVIRONMENTAL CONDITIONS	19deg. C, 66%RH	TESTED BY	Kent Liu

ANTENNA POLARITY & TEST DISTANCE: HORIZONTAL AT 3 M								
NO.	FREQ. (MHz)	EMISSION LEVEL (dBuV/m)	LIMIT (dBuV/m)	MARGIN (dB)	ANTENNA HEIGHT (m)	TABLE ANGLE (Degree)	RAW VALUE (dBuV)	CORRECTION FACTOR (dB/m)
1	2390.00	69.0 PK	74.0	-5.0	1.06 H	69	37.25	31.75
2	2390.00	48.9 AV	54.0	-5.1	1.06 H	69	17.15	31.75
3	*2412.00	105.9 PK			1.06 H	72	74.08	31.82
4	*2412.00	85.8 AV			1.06 H	72	53.98	31.82
5	4824.00	46.7 PK	74.0	-27.3	1.25 H	153	7.34	39.36
6	4824.00	34.2 AV	54.0	-19.8	1.25 H	153	-5.16	39.36
ANTENNA POLARITY & TEST DISTANCE: VERTICAL AT 3 M								
NO.	FREQ. (MHz)	EMISSION LEVEL (dBuV/m)	LIMIT (dBuV/m)	MARGIN (dB)	ANTENNA HEIGHT (m)	TABLE ANGLE (Degree)	RAW VALUE (dBuV)	CORRECTION FACTOR (dB/m)
1	2390.00	71.9 PK	74.0	-2.1	1.51 V	296	40.15	31.75
2	2390.00	52.8 AV	54.0	-1.2	1.51 V	296	21.05	31.75
3	*2412.00	111.1 PK			1.51 V	296	79.28	31.82
4	*2412.00	97.9 AV			1.51 V	296	66.08	31.82
5	4824.00	45.9 PK	74.0	-28.1	1.00 V	265	6.54	39.36
6	4824.00	34.5 AV	54.0	-19.5	1.00 V	265	-4.86	39.36

- REMARKS:**
1. Emission level (dBuV/m) = Raw Value (dBuV) + Correction Factor (dB/m).
 2. Correction Factor (dB/m) = Antenna Factor (dB/m) + Cable Factor (dB).
 3. The other emission levels were very low against the limit.
 4. Margin value = Emission level – Limit value.
 5. “ * “: Fundamental frequency.



A D T

EUT TEST CONDITION		MEASUREMENT DETAIL	
CHANNEL	Channel 2	FREQUENCY RANGE	1 ~ 25GHz
INPUT POWER	DC 3.3V	DETECTOR FUNCTION	Peak (PK) Average (AV)
ENVIRONMENTAL CONDITIONS	19deg. C, 66%RH	TESTED BY	Kent Liu

ANTENNA POLARITY & TEST DISTANCE: HORIZONTAL AT 3 M

NO.	FREQ. (MHz)	EMISSION LEVEL (dBuV/m)	LIMIT (dBuV/m)	MARGIN (dB)	ANTENNA HEIGHT (m)	TABLE ANGLE (Degree)	RAW VALUE (dBuV)	CORRECTION FACTOR (dB/m)
1	2390.00	67.6 PK	74.0	-6.4	1.06 H	49	35.85	31.75
2	2390.00	48.9 AV	54.0	-5.1	1.06 H	49	17.15	31.75
3	*2417.00	107.4 PK			1.07 H	56	75.56	31.84
4	*2417.00	86.6 AV			1.07 H	56	54.76	31.84
5	4834.00	47.0 PK	74.0	-27.0	1.21 H	157	7.61	39.39
6	4834.00	34.4 AV	54.0	-19.6	1.21 H	157	-4.99	39.39
7	7251.00	51.6 PK	74.0	-22.4	1.66 H	218	4.68	46.92
8	7251.00	40.3 AV	54.0	-13.7	1.66 H	218	-6.62	46.92

ANTENNA POLARITY & TEST DISTANCE: VERTICAL AT 3 M

NO.	FREQ. (MHz)	EMISSION LEVEL (dBuV/m)	LIMIT (dBuV/m)	MARGIN (dB)	ANTENNA HEIGHT (m)	TABLE ANGLE (Degree)	RAW VALUE (dBuV)	CORRECTION FACTOR (dB/m)
1	2390.00	71.5 PK	74.0	-2.5	1.53 V	302	39.75	31.75
2	2390.00	52.9 AV	54.0	-1.1	1.53 V	302	21.15	31.75
3	*2417.00	112.5 PK			1.53 V	302	80.66	31.84
4	*2417.00	99.2 AV			1.53 V	302	67.36	31.84
5	4834.00	46.2 PK	74.0	-27.8	1.00 V	259	6.81	39.39
6	4834.00	34.6 AV	54.0	-19.4	1.00 V	259	-4.79	39.39
7	7251.00	52.4 PK	74.0	-21.6	1.43 V	70	5.48	46.92
8	7251.00	41.3 AV	54.0	-12.7	1.43 V	70	-5.62	46.92

- REMARKS:**
1. Emission level (dBuV/m) = Raw Value (dBuV) + Correction Factor (dB/m).
 2. Correction Factor (dB/m) = Antenna Factor (dB/m) + Cable Factor (dB).
 3. The other emission levels were very low against the limit.
 4. Margin value = Emission level – Limit value.
 5. “ * “: Fundamental frequency.



A D T

EUT TEST CONDITION		MEASUREMENT DETAIL	
CHANNEL	Channel 3	FREQUENCY RANGE	1 ~ 25GHz
INPUT POWER	DC 3.3V	DETECTOR FUNCTION	Peak (PK) Average (AV)
ENVIRONMENTAL CONDITIONS	19deg. C, 66%RH	TESTED BY	Kent Liu

ANTENNA POLARITY & TEST DISTANCE: HORIZONTAL AT 3 M

NO.	FREQ. (MHz)	EMISSION LEVEL (dBuV/m)	LIMIT (dBuV/m)	MARGIN (dB)	ANTENNA HEIGHT (m)	TABLE ANGLE (Degree)	RAW VALUE (dBuV)	CORRECTION FACTOR (dB/m)
1	2390.00	67.4 PK	74.0	-6.6	1.63 H	238	35.65	31.75
2	2390.00	47.3 AV	54.0	-6.7	1.63 H	238	15.55	31.75
3	*2422.00	105.6 PK			1.63 H	238	73.74	31.86
4	*2422.00	91.5 AV			1.63 H	238	59.64	31.86
5	4844.00	46.7 PK	74.0	-27.3	1.21 H	139	7.28	39.42
6	4844.00	34.5 AV	54.0	-19.5	1.21 H	139	-4.92	39.42
7	7266.00	52.4 PK	74.0	-21.6	1.54 H	124	5.49	46.91
8	7266.00	41.8 AV	54.0	-12.2	1.54 H	124	-5.11	46.91

ANTENNA POLARITY & TEST DISTANCE: VERTICAL AT 3 M

NO.	FREQ. (MHz)	EMISSION LEVEL (dBuV/m)	LIMIT (dBuV/m)	MARGIN (dB)	ANTENNA HEIGHT (m)	TABLE ANGLE (Degree)	RAW VALUE (dBuV)	CORRECTION FACTOR (dB/m)
1	2390.00	65.6 PK	74.0	-8.4	1.53 V	252	33.85	31.75
2	2390.00	47.0 AV	54.0	-7.0	1.53 V	252	15.25	31.75
3	*2422.00	114.6 PK			1.53 V	252	82.74	31.86
4	*2422.00	102.3 AV			1.53 V	252	70.44	31.86
5	4844.00	46.8 PK	74.0	-27.2	1.01 V	273	7.38	39.42
6	4844.00	35.0 AV	54.0	-19.0	1.01 V	273	-4.42	39.42
7	7266.00	53.7 PK	74.0	-20.3	1.49 V	86	6.79	46.91
8	7266.00	42.2 AV	54.0	-11.8	1.49 V	86	-4.71	46.91

- REMARKS:**
1. Emission level (dBuV/m) = Raw Value (dBuV) + Correction Factor (dB/m).
 2. Correction Factor (dB/m) = Antenna Factor (dB/m) + Cable Factor (dB).
 3. The other emission levels were very low against the limit.
 4. Margin value = Emission level – Limit value.
 5. “ * “: Fundamental frequency.



A D T

EUT TEST CONDITION		MEASUREMENT DETAIL	
CHANNEL	Channel 6	FREQUENCY RANGE	1 ~ 25GHz
INPUT POWER	DC 3.3V	DETECTOR FUNCTION	Peak (PK) Average (AV)
ENVIRONMENTAL CONDITIONS	19deg. C, 66%RH	TESTED BY	Kent Liu

ANTENNA POLARITY & TEST DISTANCE: HORIZONTAL AT 3 M								
NO.	FREQ. (MHz)	EMISSION LEVEL (dBuV/m)	LIMIT (dBuV/m)	MARGIN (dB)	ANTENNA HEIGHT (m)	TABLE ANGLE (Degree)	RAW VALUE (dBuV)	CORRECTION FACTOR (dB/m)
1	*2437.00	108.1 PK			1.07 H	80	76.18	31.92
2	*2437.00	87.2 AV			1.07 H	80	55.28	31.92
3	4874.00	46.5 PK	74.0	-27.5	1.24 H	151	7.00	39.50
4	4874.00	34.2 AV	54.0	-19.8	1.24 H	151	-5.30	39.50
5	7311.00	52.0 PK	74.0	-22.0	1.56 H	111	5.12	46.88
6	7311.00	41.4 AV	54.0	-12.6	1.56 H	111	-5.48	46.88
ANTENNA POLARITY & TEST DISTANCE: VERTICAL AT 3 M								
NO.	FREQ. (MHz)	EMISSION LEVEL (dBuV/m)	LIMIT (dBuV/m)	MARGIN (dB)	ANTENNA HEIGHT (m)	TABLE ANGLE (Degree)	RAW VALUE (dBuV)	CORRECTION FACTOR (dB/m)
1	*2437.00	114.7 PK			1.52 V	265	82.78	31.92
2	*2437.00	102.4 AV			1.52 V	265	70.48	31.92
3	4874.00	47.3 PK	74.0	-26.7	1.00 V	271	7.80	39.50
4	4874.00	35.2 AV	54.0	-18.8	1.00 V	271	-4.30	39.50
5	7311.00	53.8 PK	74.0	-20.2	1.56 V	76	6.92	46.88
6	7311.00	42.5 AV	54.0	-11.5	1.56 V	76	-4.38	46.88

- REMARKS:**
1. Emission level (dBuV/m) = Raw Value (dBuV) + Correction Factor (dB/m).
 2. Correction Factor (dB/m) = Antenna Factor (dB/m) + Cable Factor (dB).
 3. The other emission levels were very low against the limit.
 4. Margin value = Emission level – Limit value.
 5. “ * “: Fundamental frequency.



A D T

EUT TEST CONDITION		MEASUREMENT DETAIL	
CHANNEL	Channel 9	FREQUENCY RANGE	1 ~ 25GHz
INPUT POWER	DC 3.3V	DETECTOR FUNCTION	Peak (PK) Average (AV)
ENVIRONMENTAL CONDITIONS	19deg. C, 66%RH	TESTED BY	Kent Liu

ANTENNA POLARITY & TEST DISTANCE: HORIZONTAL AT 3 M

NO.	FREQ. (MHz)	EMISSION LEVEL (dBuV/m)	LIMIT (dBuV/m)	MARGIN (dB)	ANTENNA HEIGHT (m)	TABLE ANGLE (Degree)	RAW VALUE (dBuV)	CORRECTION FACTOR (dB/m)
1	*2452.00	106.5 PK			1.66 H	232	74.53	31.97
2	*2452.00	91.6 AV			1.66 H	232	59.63	31.97
3	2483.50	62.7 PK	74.0	-11.3	1.62 H	232	30.61	32.09
4	2483.50	45.4 AV	54.0	-8.6	1.62 H	232	13.31	32.09
5	4904.00	46.2 PK	74.0	-27.8	1.24 H	155	6.60	39.60
6	4904.00	33.9 AV	54.0	-20.1	1.24 H	155	-5.70	39.60
7	7356.00	51.9 PK	74.0	-22.1	1.61 H	124	5.07	46.83
8	7356.00	41.2 AV	54.0	-12.8	1.61 H	124	-5.63	46.83

ANTENNA POLARITY & TEST DISTANCE: VERTICAL AT 3 M

NO.	FREQ. (MHz)	EMISSION LEVEL (dBuV/m)	LIMIT (dBuV/m)	MARGIN (dB)	ANTENNA HEIGHT (m)	TABLE ANGLE (Degree)	RAW VALUE (dBuV)	CORRECTION FACTOR (dB/m)
1	*2452.00	114.2 PK			1.57 V	266	82.23	31.97
2	*2452.00	102.0 AV			1.57 V	266	70.03	31.97
3	2483.50	66.7 PK	74.0	-7.3	1.53 V	263	34.61	32.09
4	2483.50	47.0 AV	54.0	-7.0	1.53 V	263	14.91	32.09
5	4904.00	46.4 PK	74.0	-27.6	1.01 V	279	6.80	39.60
6	4904.00	34.6 AV	54.0	-19.4	1.01 V	279	-5.00	39.60
7	7356.00	54.1 PK	74.0	-19.9	1.51 V	90	7.27	46.83
8	7356.00	42.5 AV	54.0	-11.5	1.51 V	90	-4.33	46.83

- REMARKS:**
1. Emission level (dBuV/m) = Raw Value (dBuV) + Correction Factor (dB/m).
 2. Correction Factor (dB/m) = Antenna Factor (dB/m) + Cable Factor (dB).
 3. The other emission levels were very low against the limit.
 4. Margin value = Emission level – Limit value.
 5. “ * “: Fundamental frequency.



A D T

EUT TEST CONDITION		MEASUREMENT DETAIL	
CHANNEL	Channel 10	FREQUENCY RANGE	1 ~ 25GHz
INPUT POWER	DC 3.3V	DETECTOR FUNCTION	Peak (PK) Average (AV)
ENVIRONMENTAL CONDITIONS	19deg. C, 66%RH	TESTED BY	Kent Liu

ANTENNA POLARITY & TEST DISTANCE: HORIZONTAL AT 3 M

NO.	FREQ. (MHz)	EMISSION LEVEL (dBuV/m)	LIMIT (dBuV/m)	MARGIN (dB)	ANTENNA HEIGHT (m)	TABLE ANGLE (Degree)	RAW VALUE (dBuV)	CORRECTION FACTOR (dB/m)
1	2457.00	107.8 PK			1.05 H	73	75.81	31.99
2	2457.00	87.1 AV			1.05 H	73	55.11	31.99
3	2483.50	68.5 PK	74.0	-5.5	1.03 H	72	36.41	32.09
4	2483.50	47.6 AV	54.0	-6.4	1.03 H	72	15.51	32.09
5	4914.00	46.6 PK	74.0	-27.4	1.16 H	156	6.97	39.63
6	4914.00	34.2 AV	54.0	-19.8	1.16 H	156	-5.43	39.63
7	7371.00	51.7 PK	74.0	-22.3	1.63 H	222	4.89	46.81
8	7371.00	40.3 AV	54.0	-13.7	1.63 H	222	-6.51	46.81

ANTENNA POLARITY & TEST DISTANCE: VERTICAL AT 3 M

NO.	FREQ. (MHz)	EMISSION LEVEL (dBuV/m)	LIMIT (dBuV/m)	MARGIN (dB)	ANTENNA HEIGHT (m)	TABLE ANGLE (Degree)	RAW VALUE (dBuV)	CORRECTION FACTOR (dB/m)
1	2457.00	112.3 PK			1.46 V	298	80.31	31.99
2	2457.00	99.0 AV			1.46 V	298	67.01	31.99
3	2483.50	72.8 PK	74.0	-1.2	1.46 V	295	40.71	32.09
4	2483.50	52.5 AV	54.0	-1.5	1.46 V	295	20.41	32.09
5	4914.00	46.7 PK	74.0	-27.3	1.03 V	285	7.07	39.63
6	4914.00	34.8 AV	54.0	-19.2	1.03 V	285	-4.83	39.63
7	7371.00	54.0 PK	74.0	-20.0	1.54 V	97	7.19	46.81
8	7371.00	42.4 AV	54.0	-11.6	1.54 V	97	-4.41	46.81

- REMARKS:**
1. Emission level (dBuV/m) = Raw Value (dBuV) + Correction Factor (dB/m).
 2. Correction Factor (dB/m) = Antenna Factor (dB/m) + Cable Factor (dB).
 3. The other emission levels were very low against the limit.
 4. Margin value = Emission level – Limit value.
 5. “ * “: Fundamental frequency.



A D T

EUT TEST CONDITION		MEASUREMENT DETAIL	
CHANNEL	Channel 11	FREQUENCY RANGE	1 ~ 25GHz
INPUT POWER	DC 3.3V	DETECTOR FUNCTION	Peak (PK) Average (AV)
ENVIRONMENTAL CONDITIONS	21deg. C, 66%RH	TESTED BY	Kent Liu

ANTENNA POLARITY & TEST DISTANCE: HORIZONTAL AT 3 M

NO.	FREQ. (MHz)	EMISSION LEVEL (dBuV/m)	LIMIT (dBuV/m)	MARGIN (dB)	ANTENNA HEIGHT (m)	TABLE ANGLE (Degree)	RAW VALUE (dBuV)	CORRECTION FACTOR (dB/m)
1	*2462.00	105.5 PK			1.03 H	68	73.61	31.89
2	*2462.00	85.2 AV			1.03 H	68	53.31	31.89
3	2483.50	69.1 PK	74.0	-4.9	1.03 H	82	37.13	31.97
4	2483.50	46.7 AV	54.0	-7.3	1.03 H	82	14.73	31.97
5	4924.00	46.4 PK	74.0	-27.6	1.18 H	148	7.09	39.31
6	4924.00	34.4 AV	54.0	-19.6	1.18 H	148	-4.91	39.31
7	7386.00	51.7 PK	74.0	-22.3	1.64 H	238	5.10	46.60
8	7386.00	40.3 AV	54.0	-13.7	1.64 H	238	-6.30	46.60

ANTENNA POLARITY & TEST DISTANCE: VERTICAL AT 3 M

NO.	FREQ. (MHz)	EMISSION LEVEL (dBuV/m)	LIMIT (dBuV/m)	MARGIN (dB)	ANTENNA HEIGHT (m)	TABLE ANGLE (Degree)	RAW VALUE (dBuV)	CORRECTION FACTOR (dB/m)
1	*2462.00	111.0 PK			1.48 V	299	79.11	31.89
2	*2462.00	98.0 AV			1.48 V	299	66.11	31.89
3	2483.50	72.9 PK	74.0	-1.1	1.48 V	297	40.93	31.97
4	2483.50	52.5 AV	54.0	-1.5	1.48 V	297	20.53	31.97
5	4924.00	46.7 PK	74.0	-27.3	1.00 V	281	7.39	39.31
6	4924.00	35.0 AV	54.0	-19.0	1.00 V	281	-4.31	39.31
7	7386.00	53.4 PK	74.0	-20.6	1.48 V	82	6.80	46.60
8	7386.00	41.9 AV	54.0	-12.1	1.48 V	82	-4.70	46.60

- REMARKS:**
1. Emission level (dBuV/m) = Raw Value (dBuV) + Correction Factor (dB/m).
 2. Correction Factor (dB/m) = Antenna Factor (dB/m) + Cable Factor (dB).
 3. The other emission levels were very low against the limit.
 4. Margin value = Emission level – Limit value.
 5. “ * “: Fundamental frequency.



A D T

EUT TEST CONDITION		MEASUREMENT DETAIL	
CHANNEL	Channel 12	FREQUENCY RANGE	1 ~ 25GHz
INPUT POWER	DC 3.3V	DETECTOR FUNCTION	Peak (PK) Average (AV)
ENVIRONMENTAL CONDITIONS	21deg. C, 66%RH	TESTED BY	Kent Liu

ANTENNA POLARITY & TEST DISTANCE: HORIZONTAL AT 3 M

NO.	FREQ. (MHz)	EMISSION LEVEL (dBuV/m)	LIMIT (dBuV/m)	MARGIN (dB)	ANTENNA HEIGHT (m)	TABLE ANGLE (Degree)	RAW VALUE (dBuV)	CORRECTION FACTOR (dB/m)
1	*2467.00	103.4 PK			1.00 H	68	71.49	31.91
2	*2467.00	83.8 AV			1.00 H	68	51.89	31.91
3	2483.50	69.0 PK	74.0	-5.0	1.00 H	68	37.03	31.97
4	2483.50	47.8 AV	54.0	-6.2	1.00 H	68	15.83	31.97
5	4934.00	46.1 PK	74.0	-27.9	1.21 H	159	6.76	39.34
6	4934.00	34.0 AV	54.0	-20.0	1.21 H	159	-5.34	39.34
7	7401.00	52.0 PK	74.0	-22.0	1.59 H	227	5.41	46.59
8	7401.00	40.5 AV	54.0	-13.5	1.59 H	227	-6.09	46.59

ANTENNA POLARITY & TEST DISTANCE: VERTICAL AT 3 M

NO.	FREQ. (MHz)	EMISSION LEVEL (dBuV/m)	LIMIT (dBuV/m)	MARGIN (dB)	ANTENNA HEIGHT (m)	TABLE ANGLE (Degree)	RAW VALUE (dBuV)	CORRECTION FACTOR (dB/m)
1	*2467.00	108.4 PK			1.44 V	295	76.49	31.91
2	*2467.00	94.5 AV			1.44 V	295	62.59	31.91
3	2483.50	72.3 PK	74.0	-1.7	1.44 V	295	40.33	31.97
4	2483.50	52.7 AV	54.0	-1.3	1.44 V	295	20.73	31.97
5	4934.00	46.5 PK	74.0	-27.5	1.03 V	293	7.16	39.34
6	4934.00	35.0 AV	54.0	-19.0	1.03 V	293	-4.34	39.34
7	7401.00	53.5 PK	74.0	-20.5	1.44 V	83	6.91	46.59
8	7401.00	42.1 AV	54.0	-11.9	1.44 V	83	-4.49	46.59

- REMARKS:**
1. Emission level (dBuV/m) = Raw Value (dBuV) + Correction Factor (dB/m).
 2. Correction Factor (dB/m) = Antenna Factor (dB/m) + Cable Factor (dB).
 3. The other emission levels were very low against the limit.
 4. Margin value = Emission level – Limit value.
 5. “ * “: Fundamental frequency.



A D T

EUT TEST CONDITION		MEASUREMENT DETAIL	
CHANNEL	Channel 13	FREQUENCY RANGE	1 ~ 25GHz
INPUT POWER	DC 3.3V	DETECTOR FUNCTION	Peak (PK) Average (AV)
ENVIRONMENTAL CONDITIONS	21deg. C, 66%RH	TESTED BY	Kent Liu

ANTENNA POLARITY & TEST DISTANCE: HORIZONTAL AT 3 M

NO.	FREQ. (MHz)	EMISSION LEVEL (dBuV/m)	LIMIT (dBuV/m)	MARGIN (dB)	ANTENNA HEIGHT (m)	TABLE ANGLE (Degree)	RAW VALUE (dBuV)	CORRECTION FACTOR (dB/m)
1	*2472.00	90.4 PK			1.00 H	70	58.35	32.05
2	*2472.00	74.0 AV			1.00 H	70	41.95	32.05
3	2483.50	66.9 PK	74.0	-7.1	1.01 H	65	34.81	32.09
4	2483.50	46.4 AV	54.0	-7.6	1.01 H	65	14.31	32.09
5	4944.00	45.9 PK	74.0	-28.1	1.21 H	151	6.15	39.75
6	4944.00	33.6 AV	54.0	-20.4	1.21 H	151	-6.15	39.75
7	7416.00	51.7 PK	74.0	-22.3	1.56 H	217	4.93	46.77
8	7416.00	40.0 AV	54.0	-14.0	1.56 H	217	-6.77	46.77

ANTENNA POLARITY & TEST DISTANCE: VERTICAL AT 3 M

NO.	FREQ. (MHz)	EMISSION LEVEL (dBuV/m)	LIMIT (dBuV/m)	MARGIN (dB)	ANTENNA HEIGHT (m)	TABLE ANGLE (Degree)	RAW VALUE (dBuV)	CORRECTION FACTOR (dB/m)
1	*2472.00	96.3 PK			1.48 V	297	64.25	32.05
2	*2472.00	82.6 AV			1.48 V	297	50.55	32.05
3	2483.50	72.9 PK	74.0	-1.1	1.44 V	296	40.81	32.09
4	2483.50	49.3 AV	54.0	-4.7	1.44 V	296	17.21	32.09
5	4944.00	46.1 PK	74.0	-27.9	1.00 V	290	6.35	39.75
6	4944.00	34.7 AV	54.0	-19.3	1.00 V	290	-5.05	39.75
7	7416.00	53.3 PK	74.0	-20.7	1.42 V	80	6.53	46.77
8	7416.00	42.1 AV	54.0	-11.9	1.42 V	80	-4.67	46.77

- REMARKS:**
1. Emission level (dBuV/m) = Raw Value (dBuV) + Correction Factor (dB/m).
 2. Correction Factor (dB/m) = Antenna Factor (dB/m) + Cable Factor (dB).
 3. The other emission levels were very low against the limit.
 4. Margin value = Emission level – Limit value.
 5. “ * “: Fundamental frequency.

RESTRICTED BANDEDGE (802.11g MODE, CH1, HORIZONTAL)

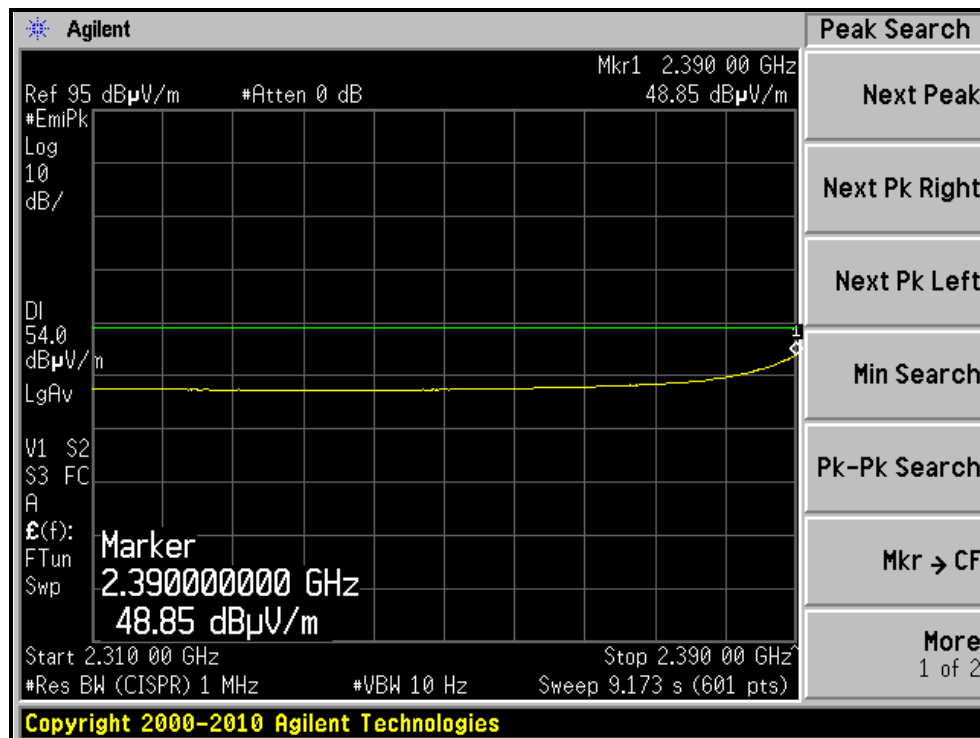
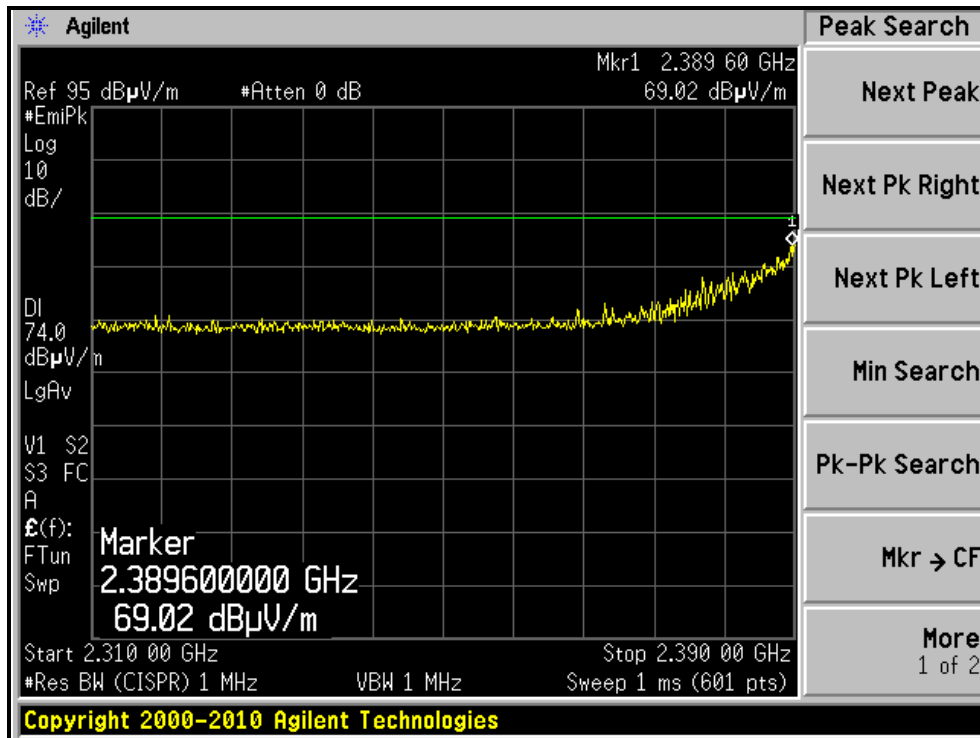

RESTRICTED BANDEDGE (802.11g MODE,CH1, VERTICAL)

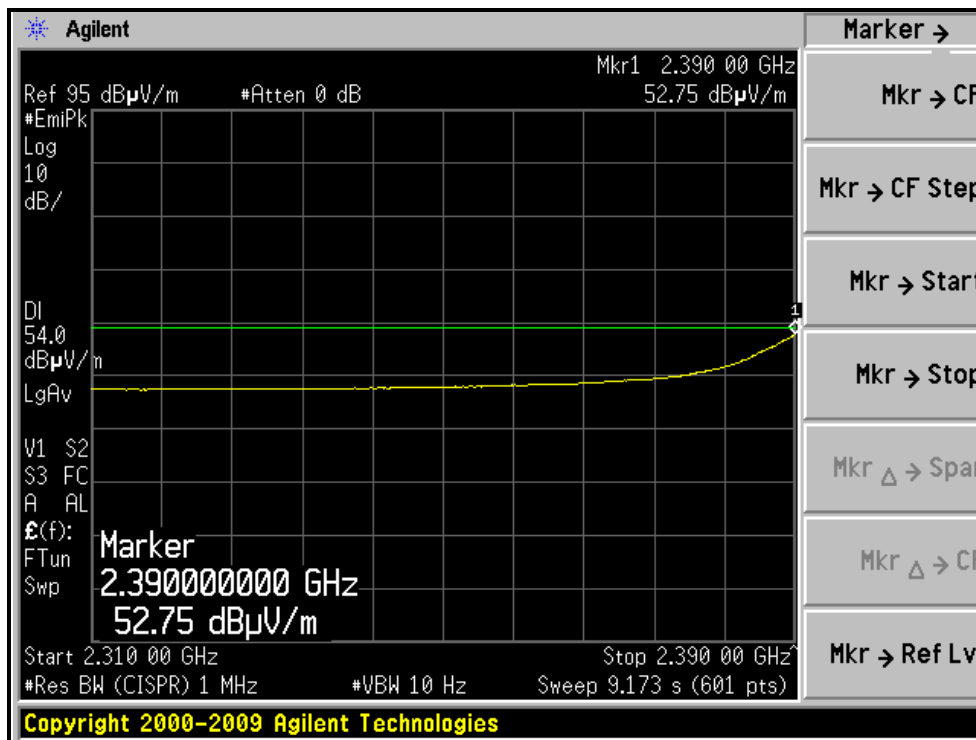
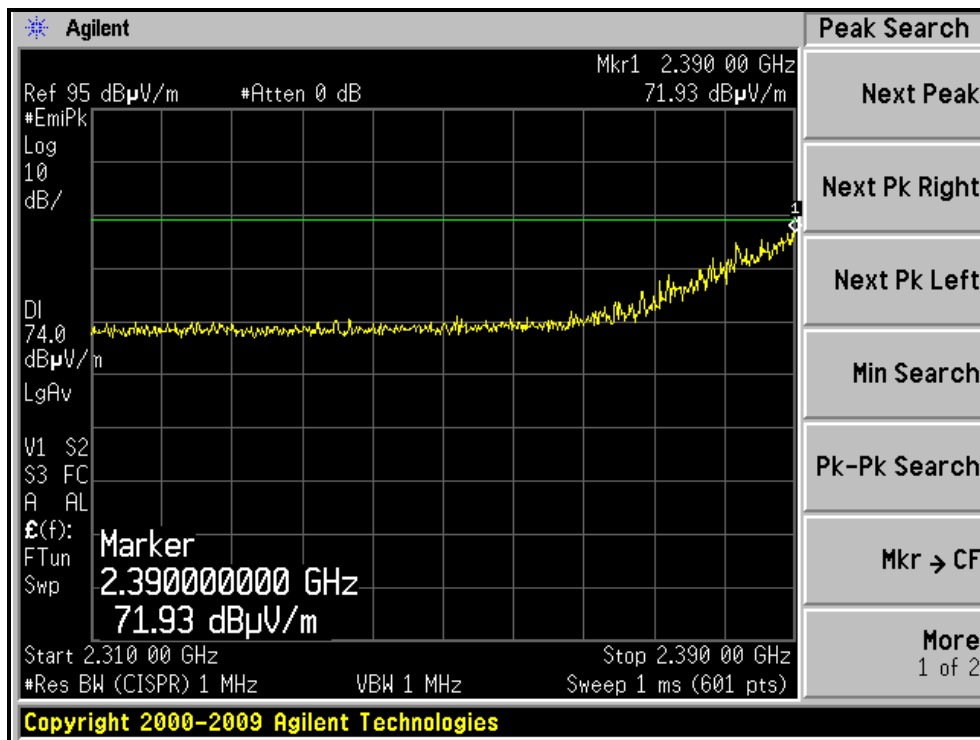



A D T

RESTRICTED BANDEDGE (802.11g MODE, CH2, HORIZONTAL)

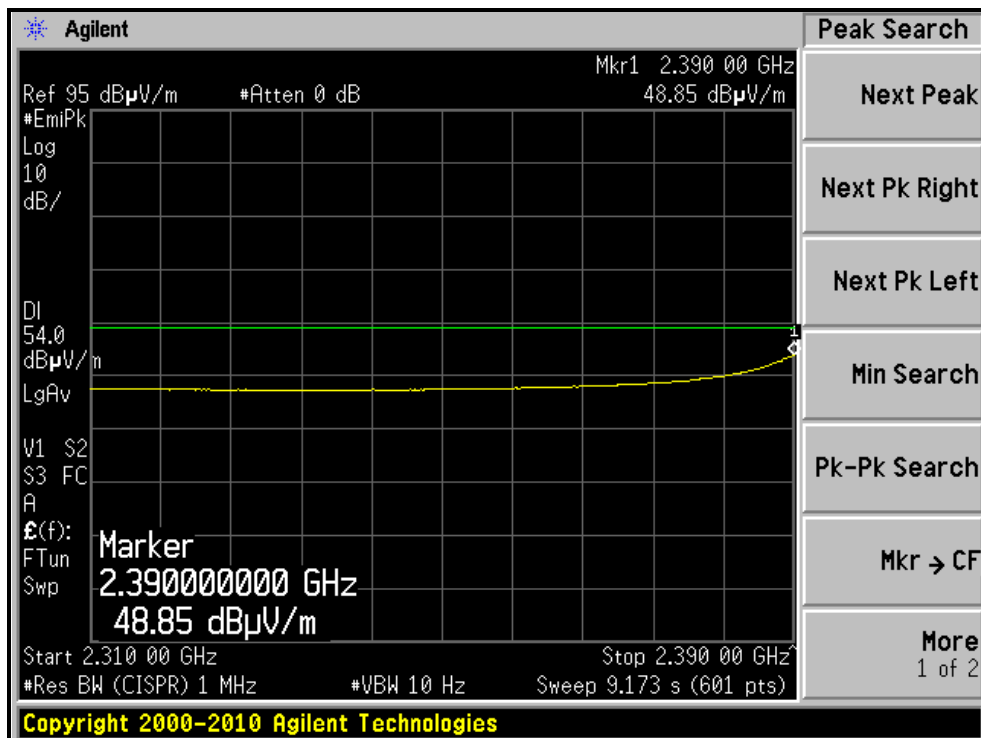
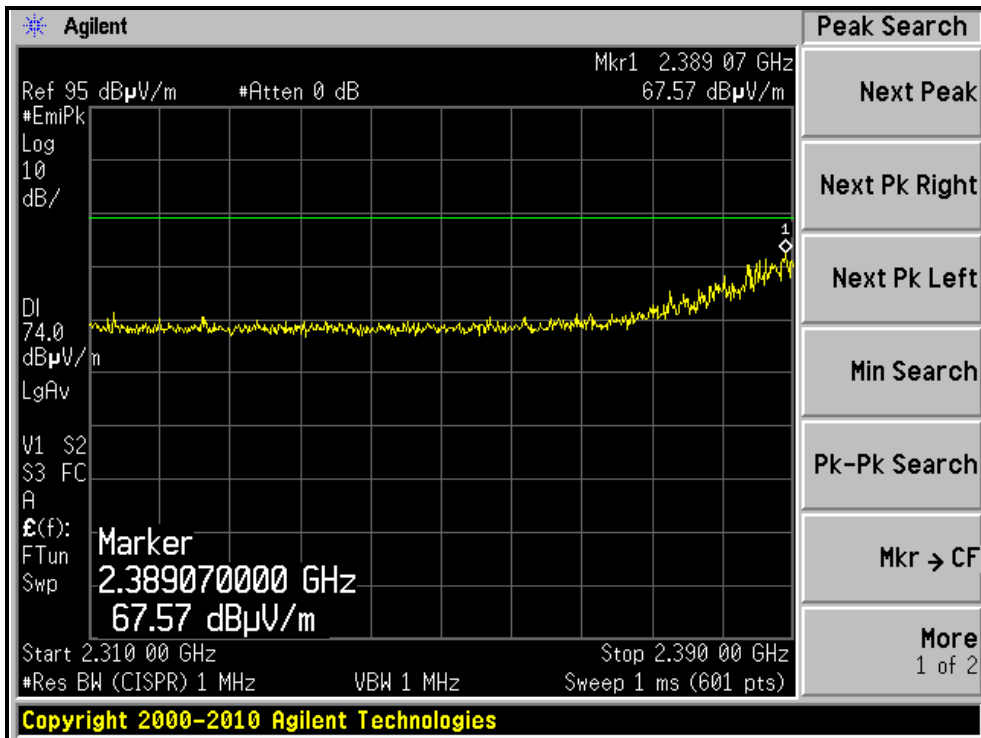

RESTRICTED BANDEDGE (802.11g MODE,CH2, VERTICAL)

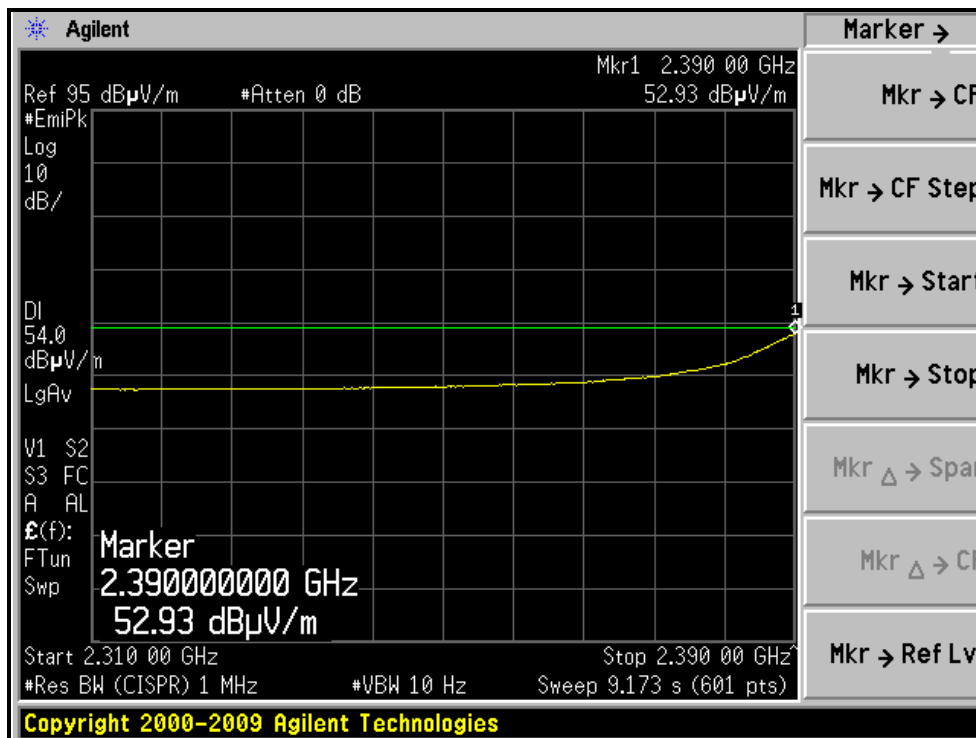
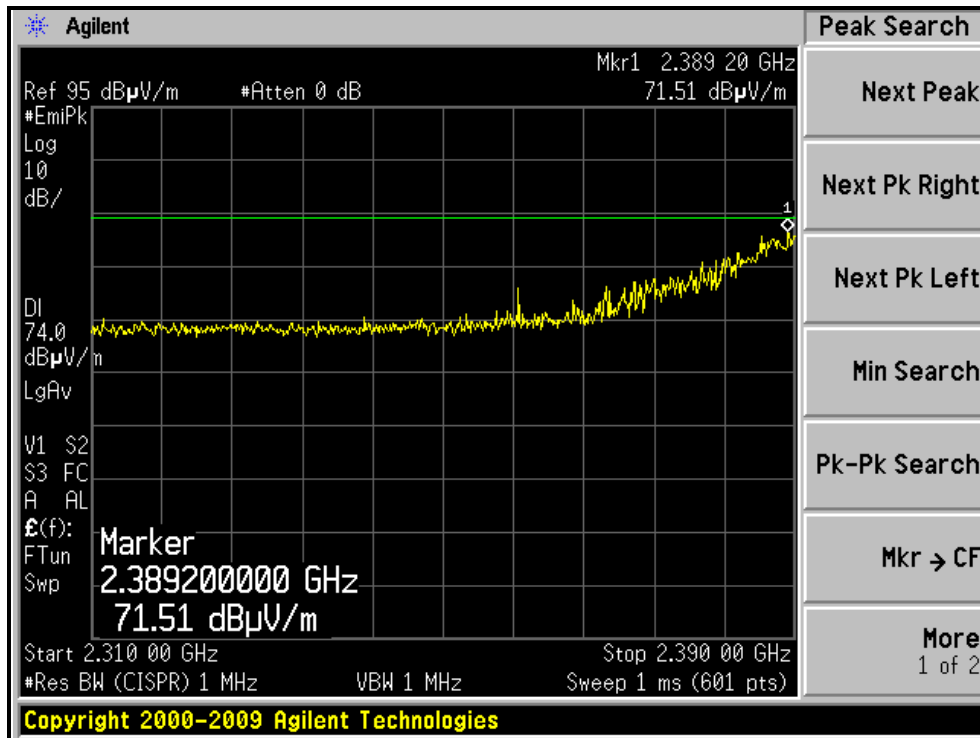

RESTRICTED BANDEDGE (802.11g MODE, CH3, HORIZONTAL)

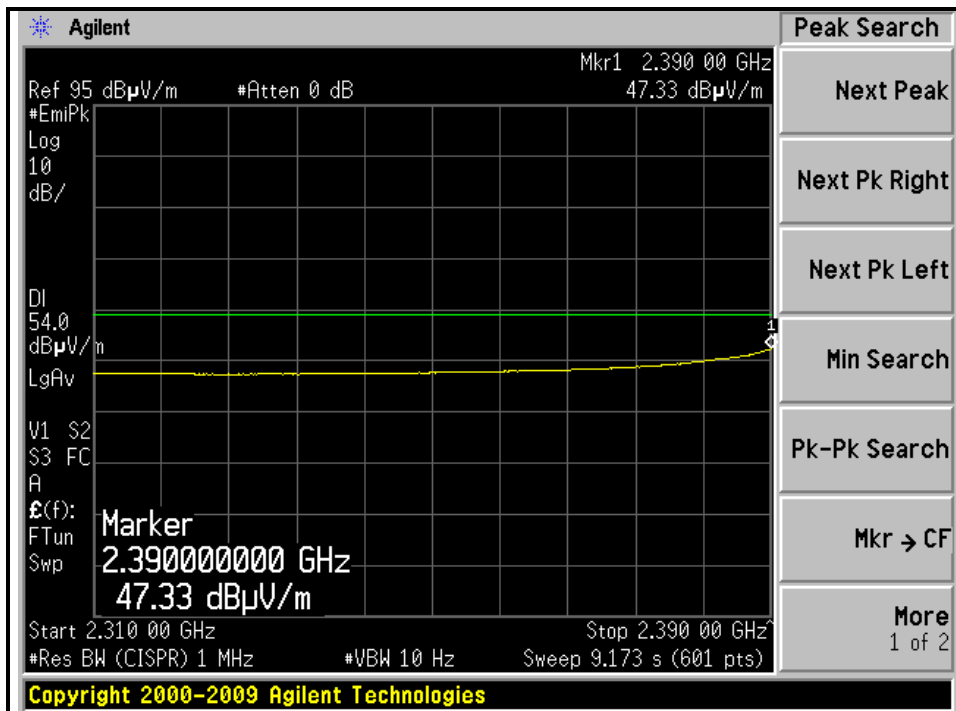
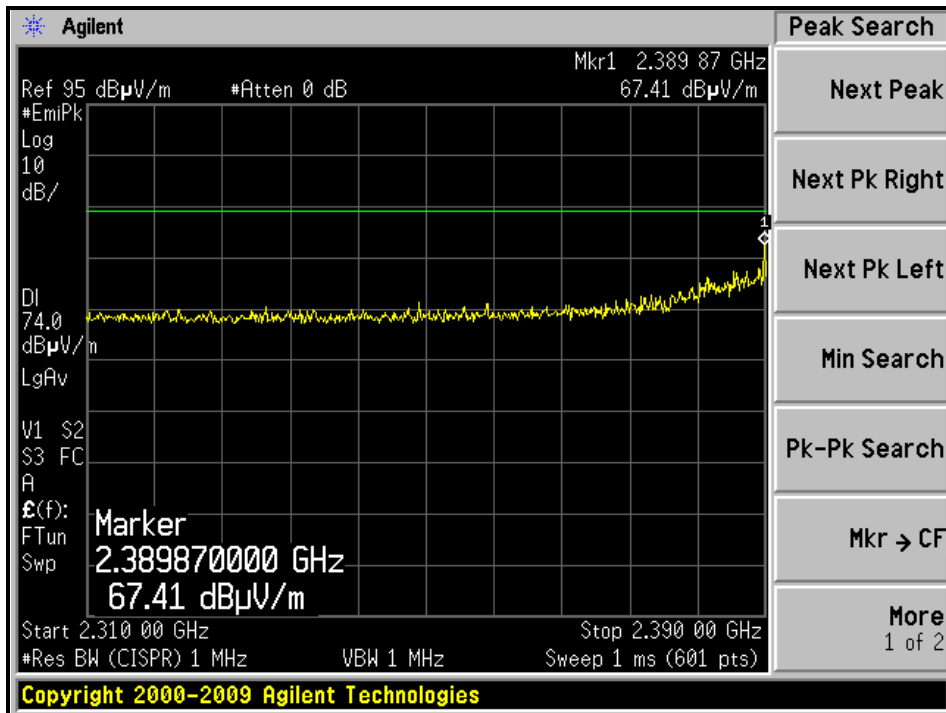

RESTRICTED BANDEDGE (802.11g MODE,CH3, VERTICAL)

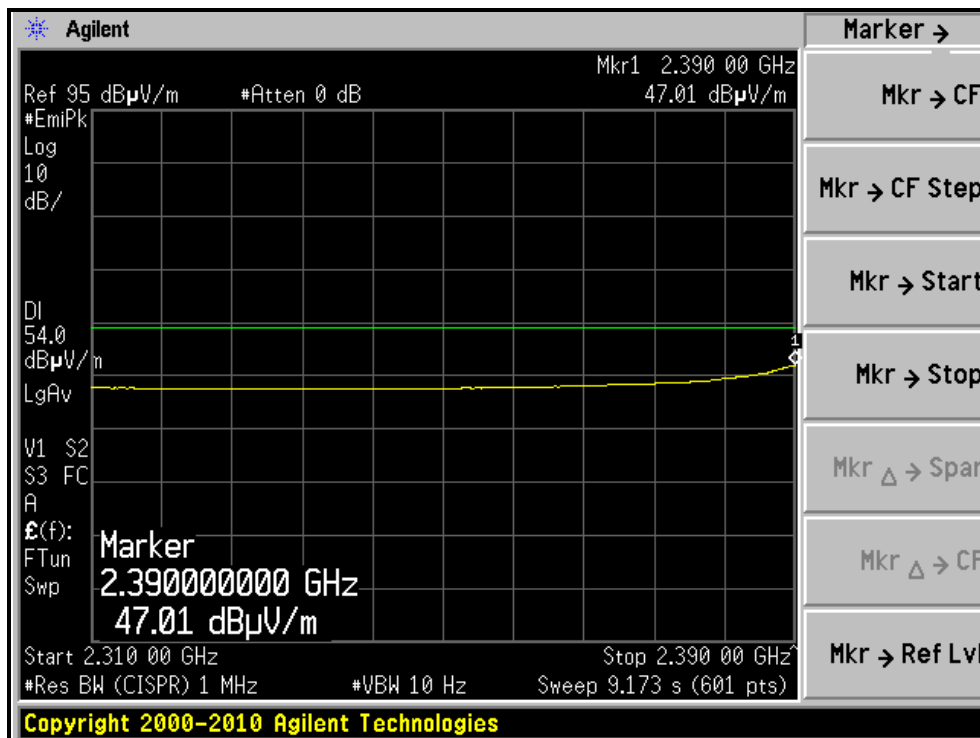
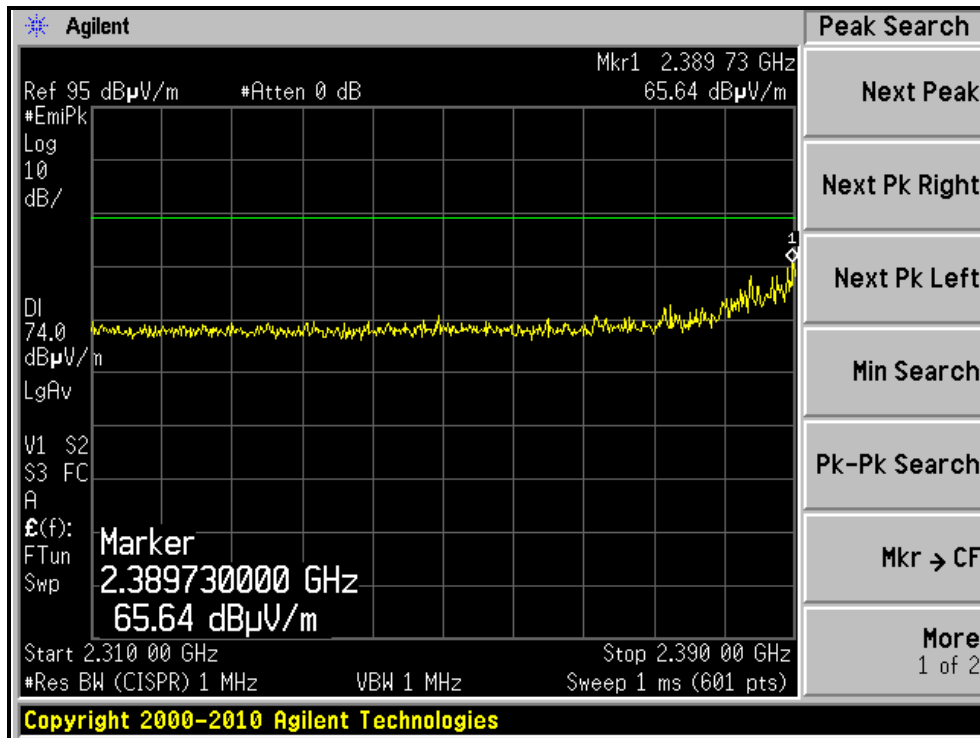

RESTRICTED BANDEDGE (802.11g MODE, CH9, HORIZONTAL)

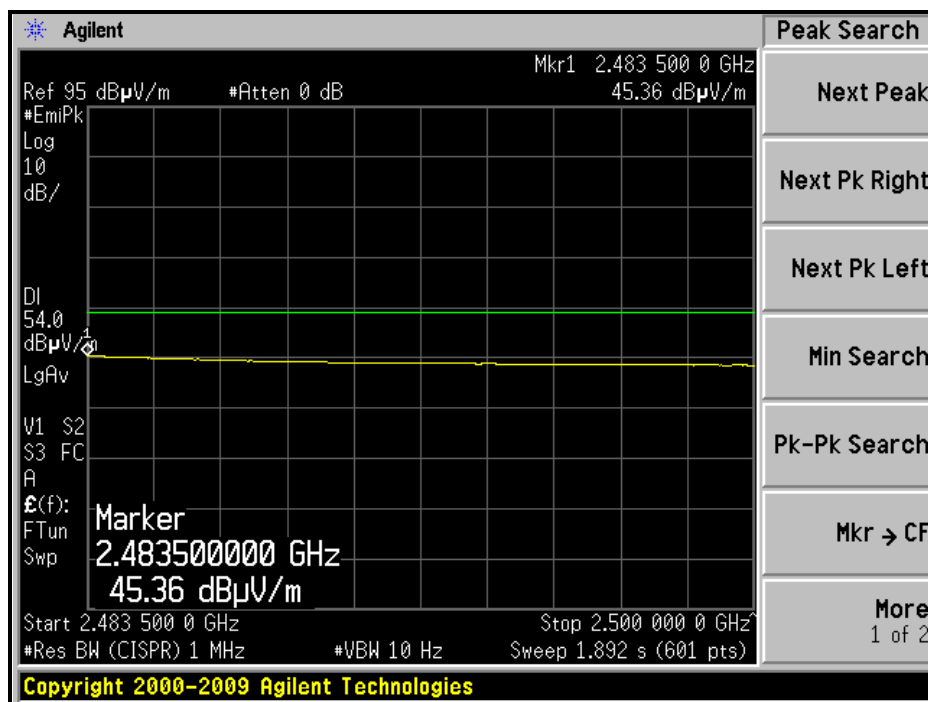
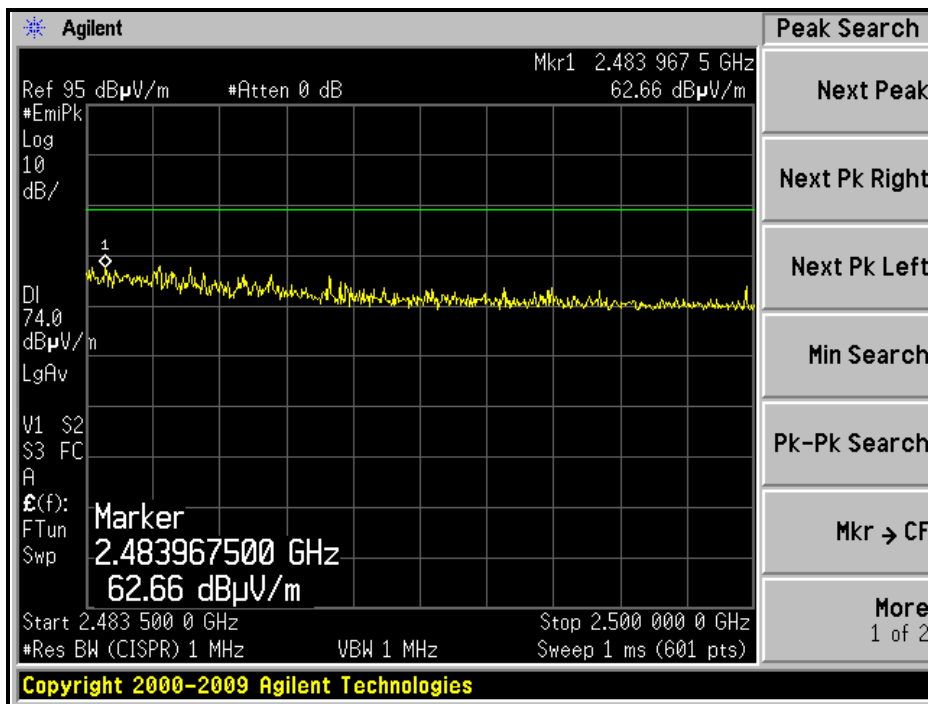

RESTRICTED BANDEDGE (802.11g MODE,CH9, VERTICAL)

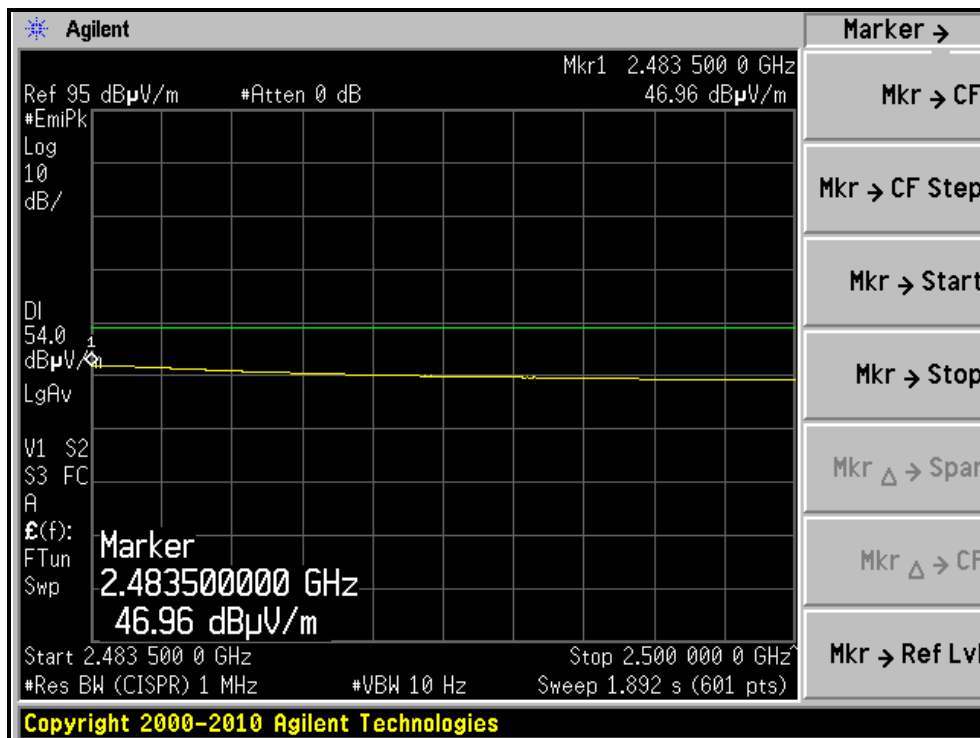
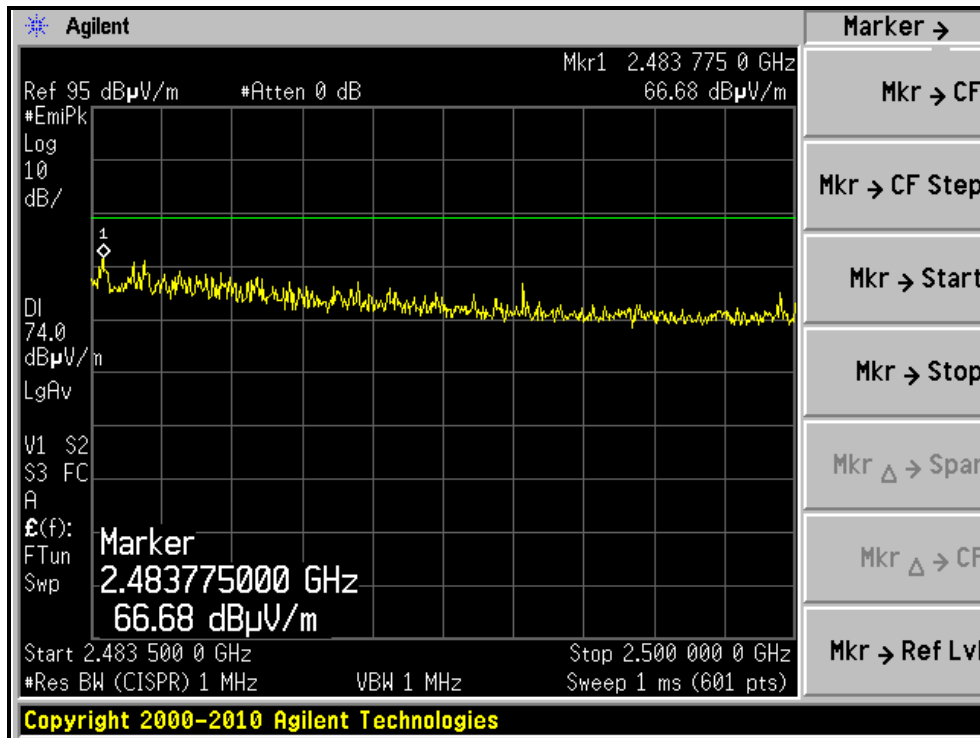

RESTRICTED BANDEDGE (802.11g MODE, CH10, HORIZONTAL)

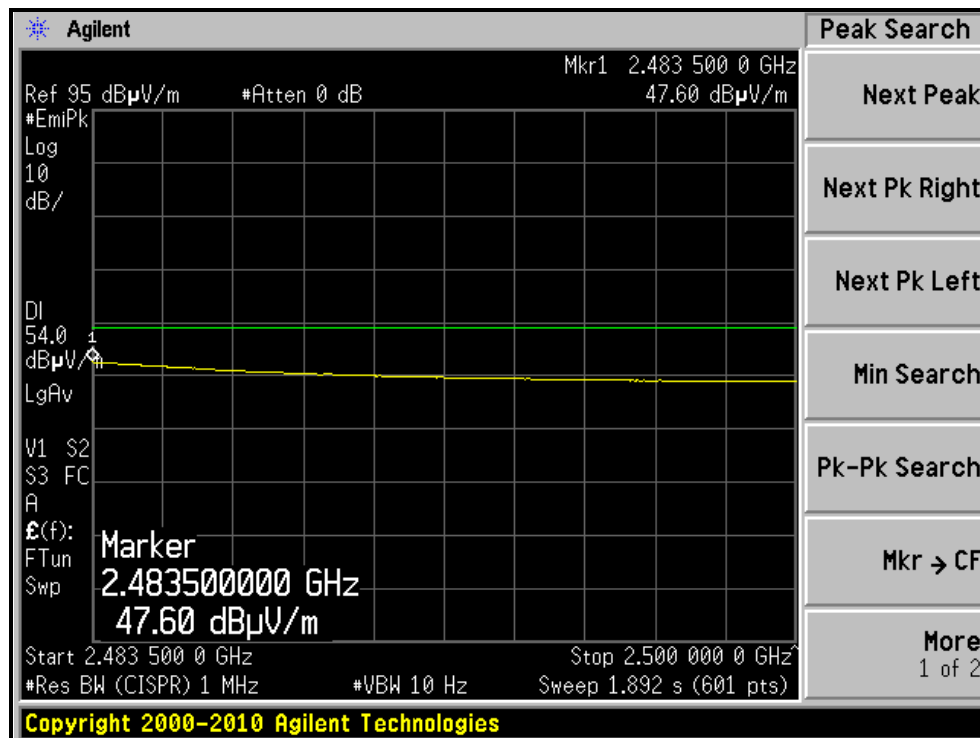
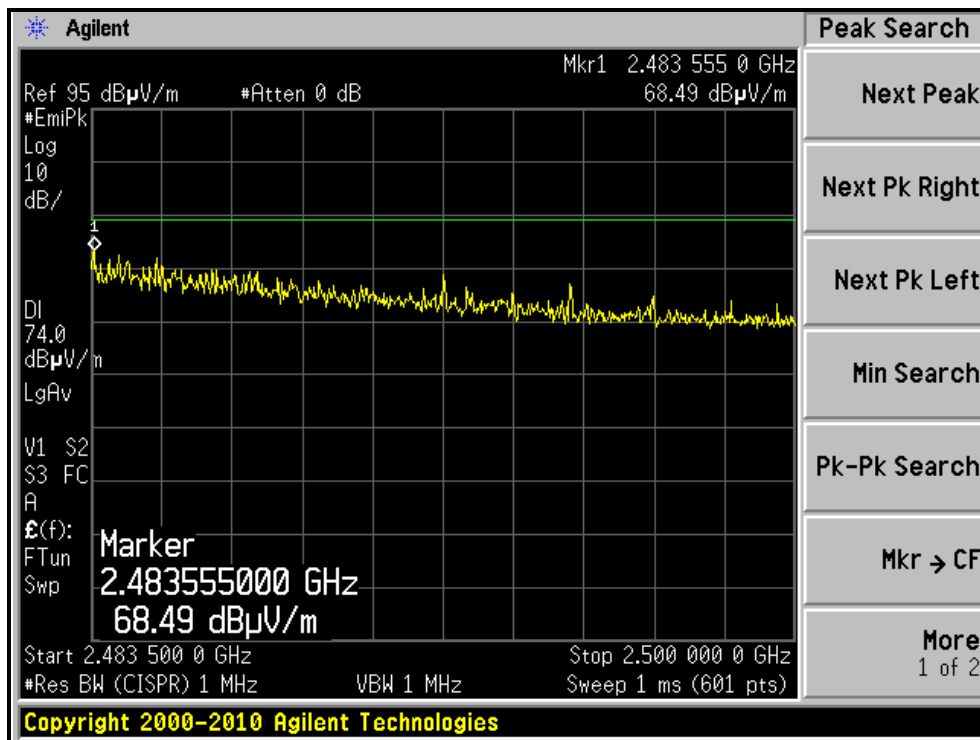

RESTRICTED BANDEDGE (802.11g MODE, CH10, VERTICAL)

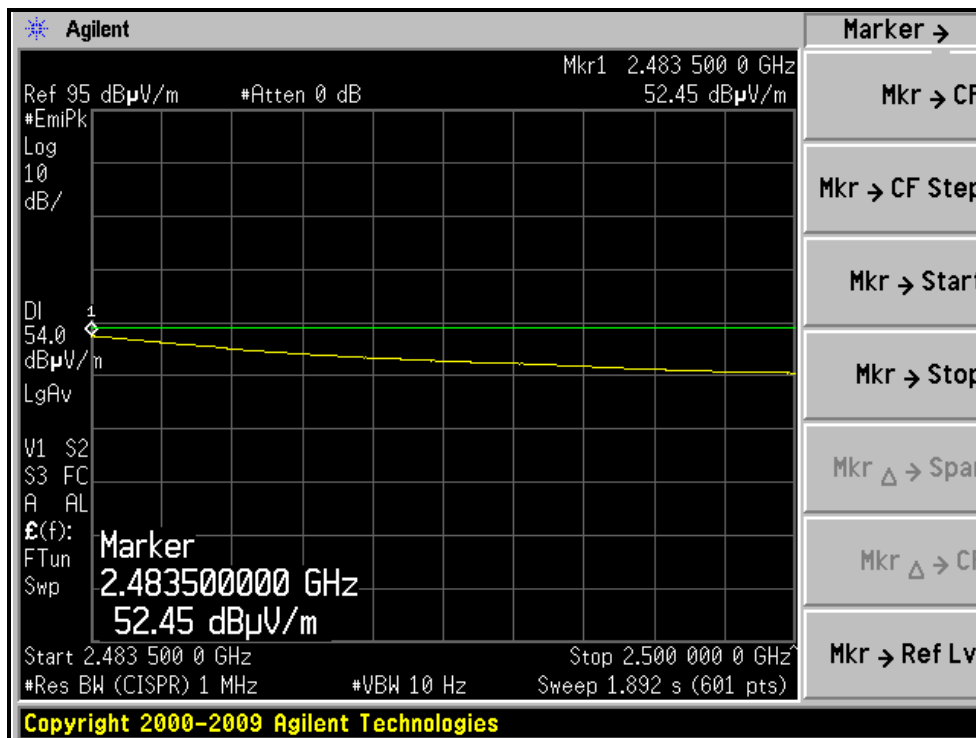
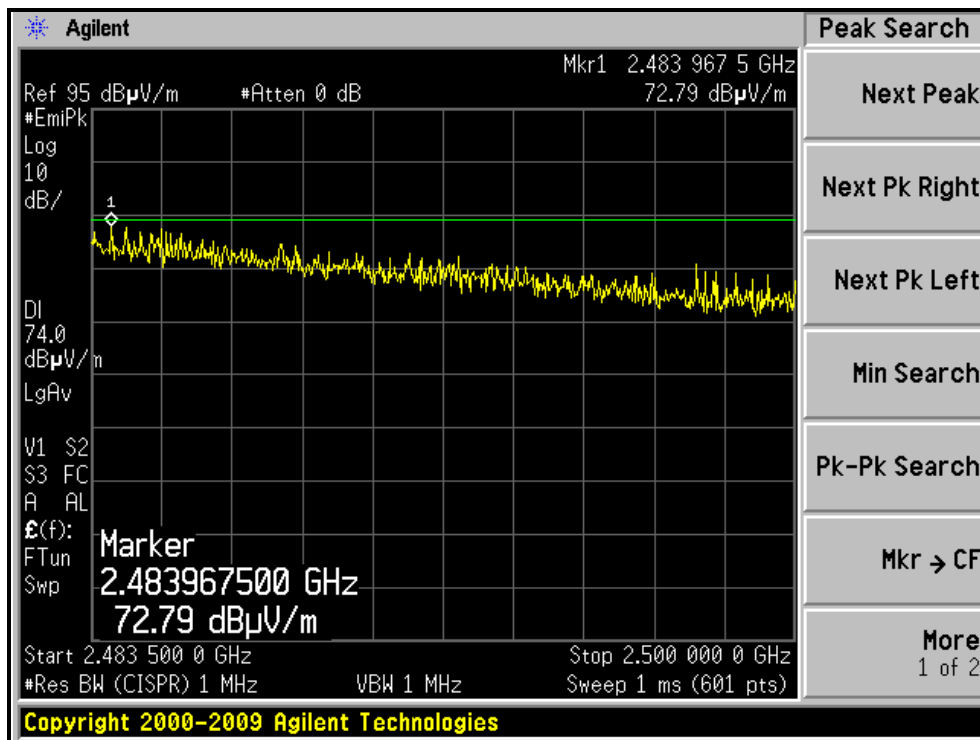



A D T

RESTRICTED BANDEDGE (802.11g MODE, CH11, HORIZONTAL)

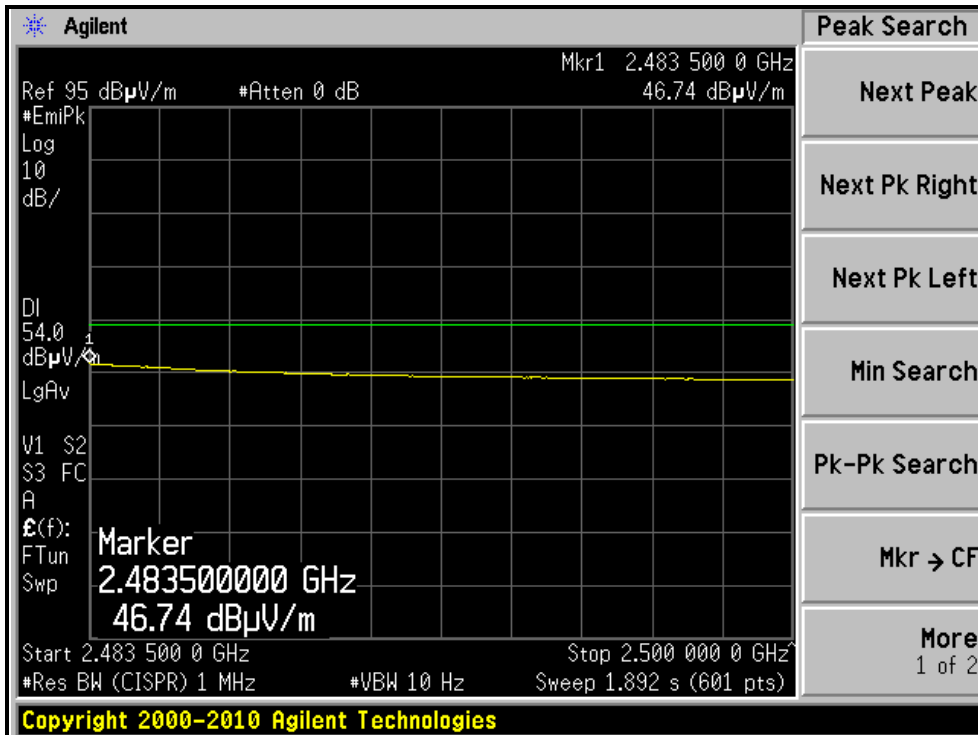
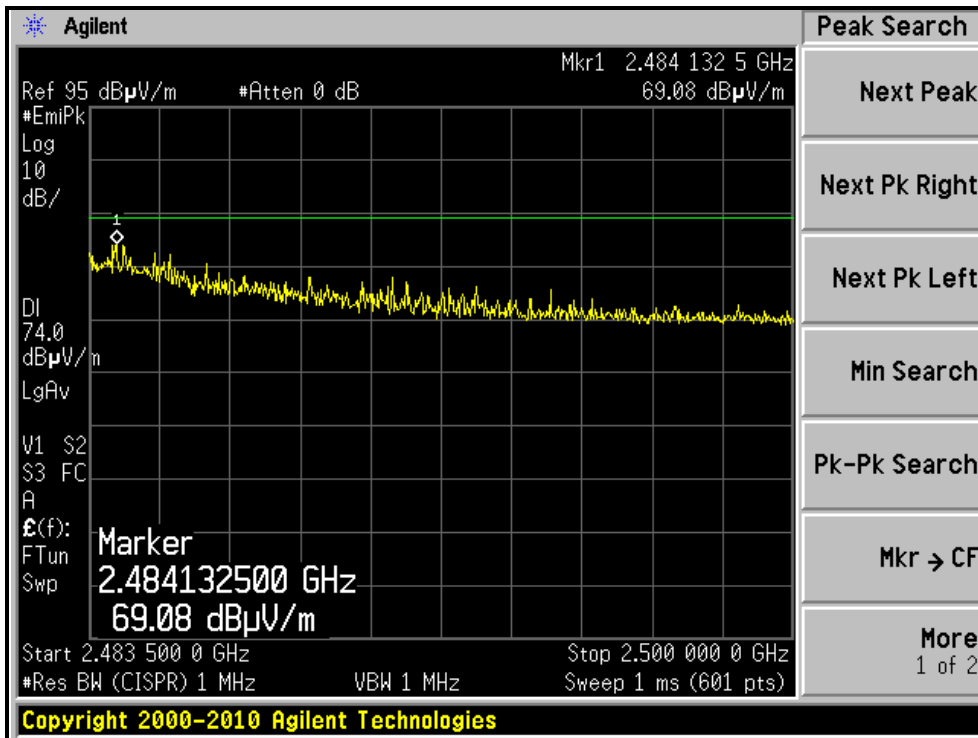

RESTRICTED BANDEDGE (802.11g MODE, CH11, VERTICAL)

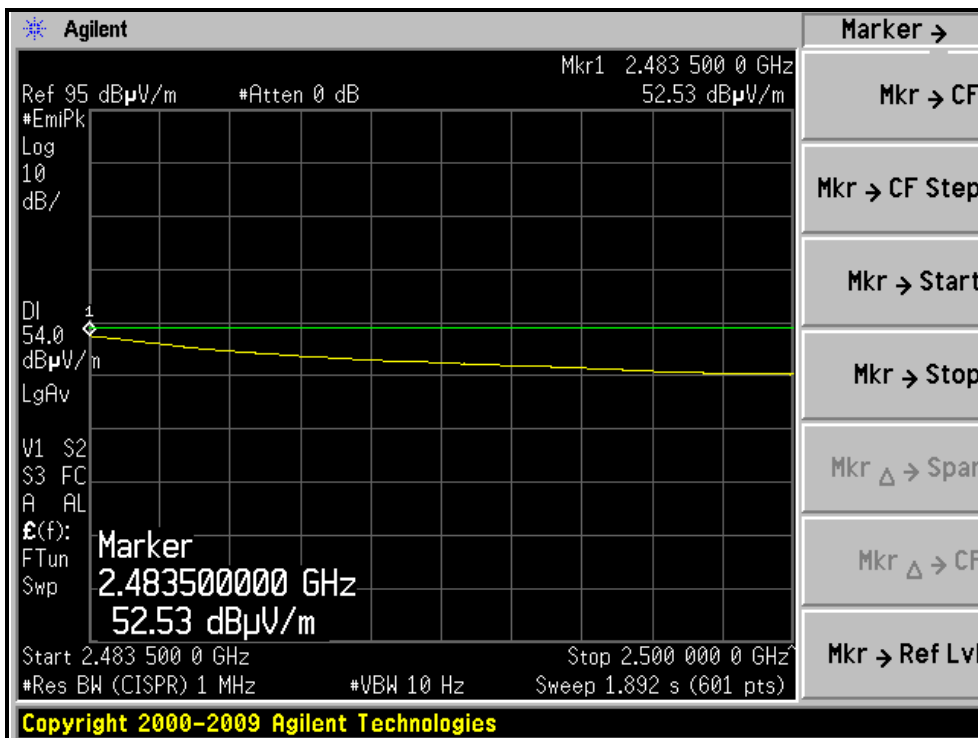
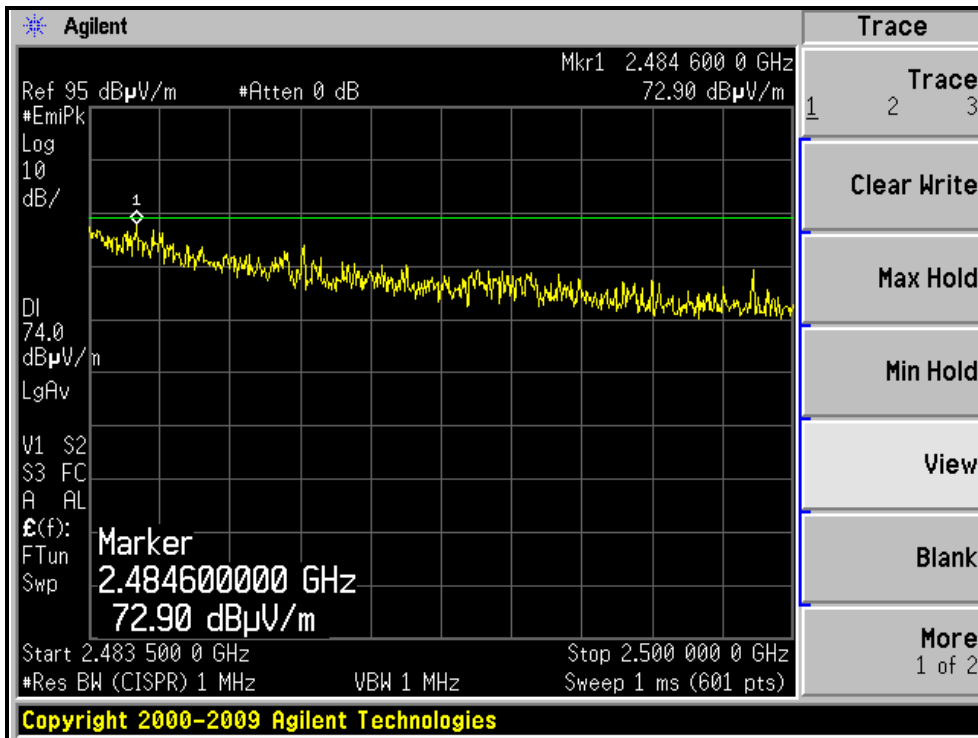



A D T

RESTRICTED BANDEDGE (802.11g MODE, CH12, HORIZONTAL)

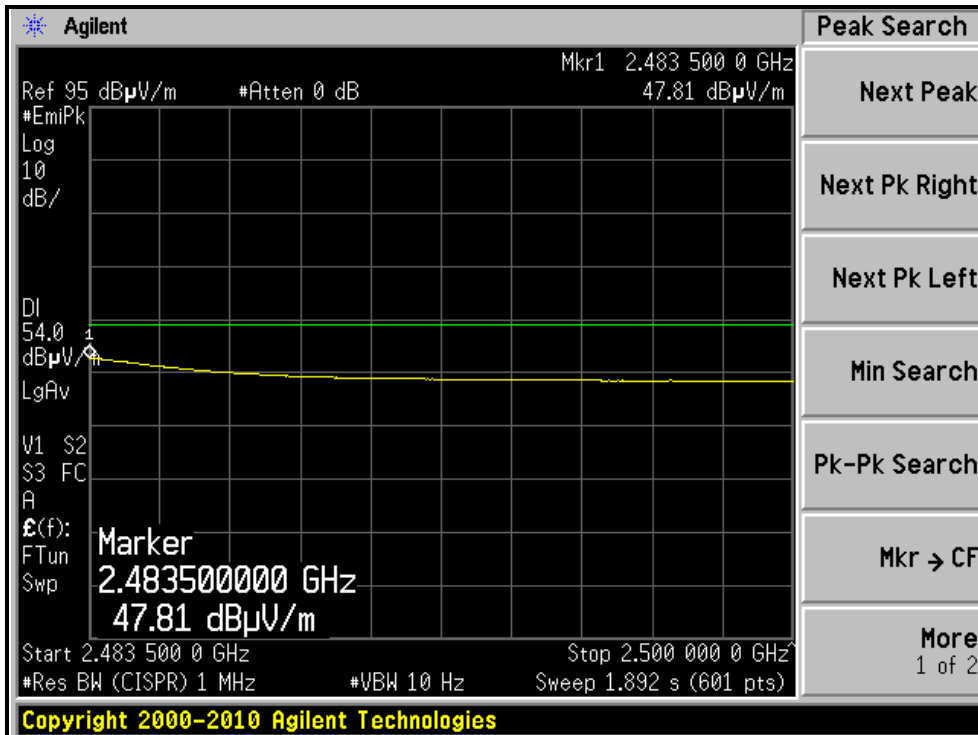
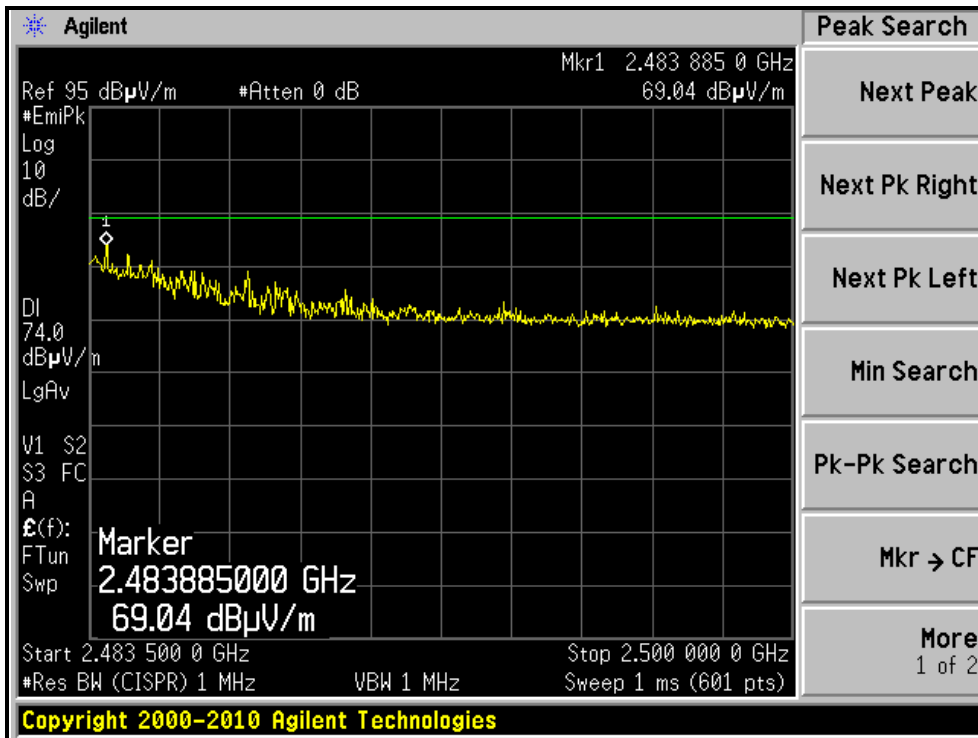

RESTRICTED BANDEDGE (802.11g MODE, CH12, VERTICAL)

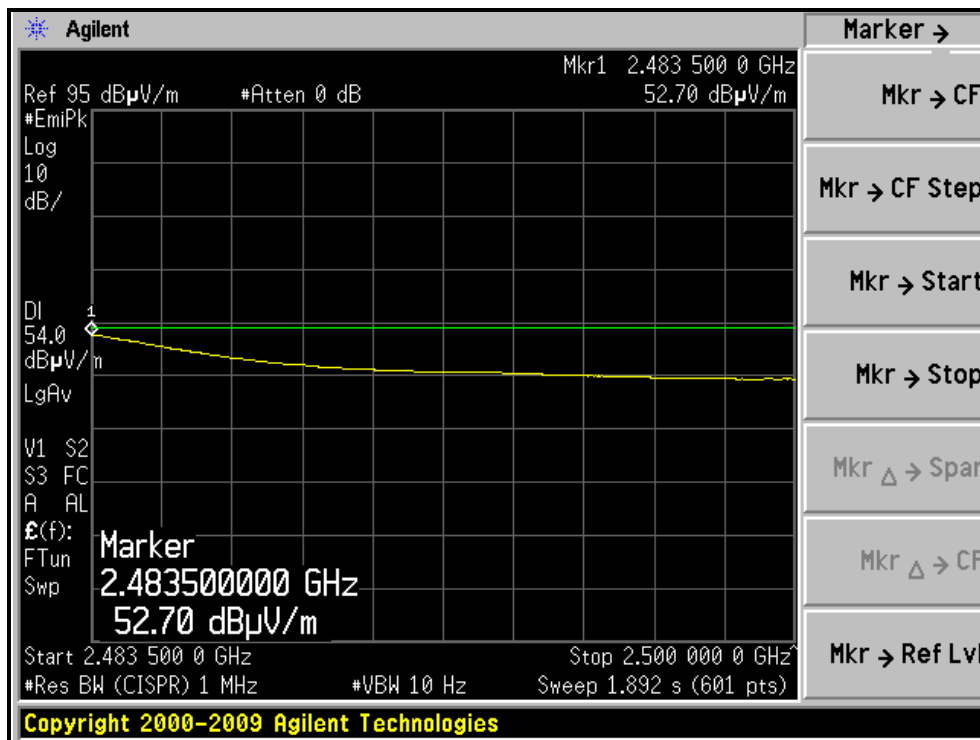
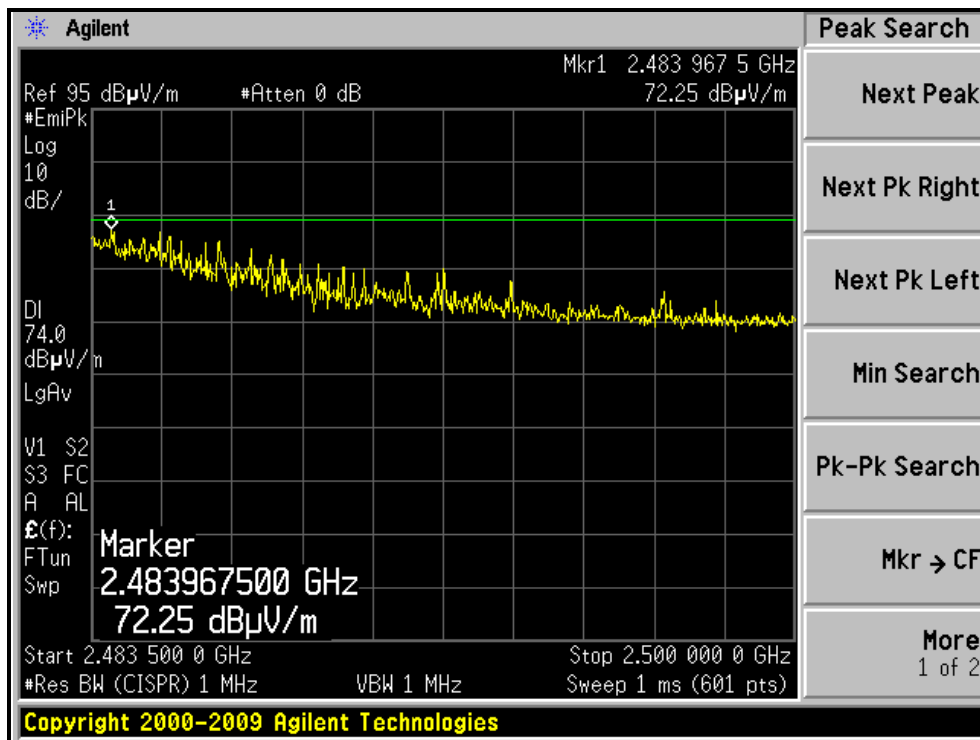

RESTRICTED BANDEDGE (802.11g MODE, CH13, HORIZONTAL)

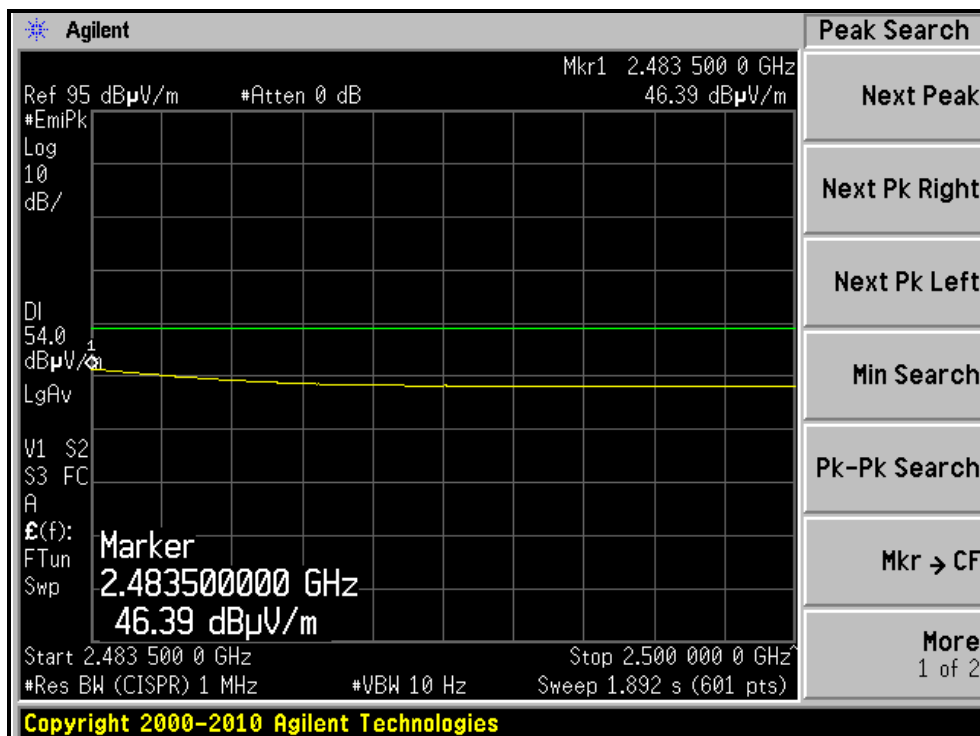
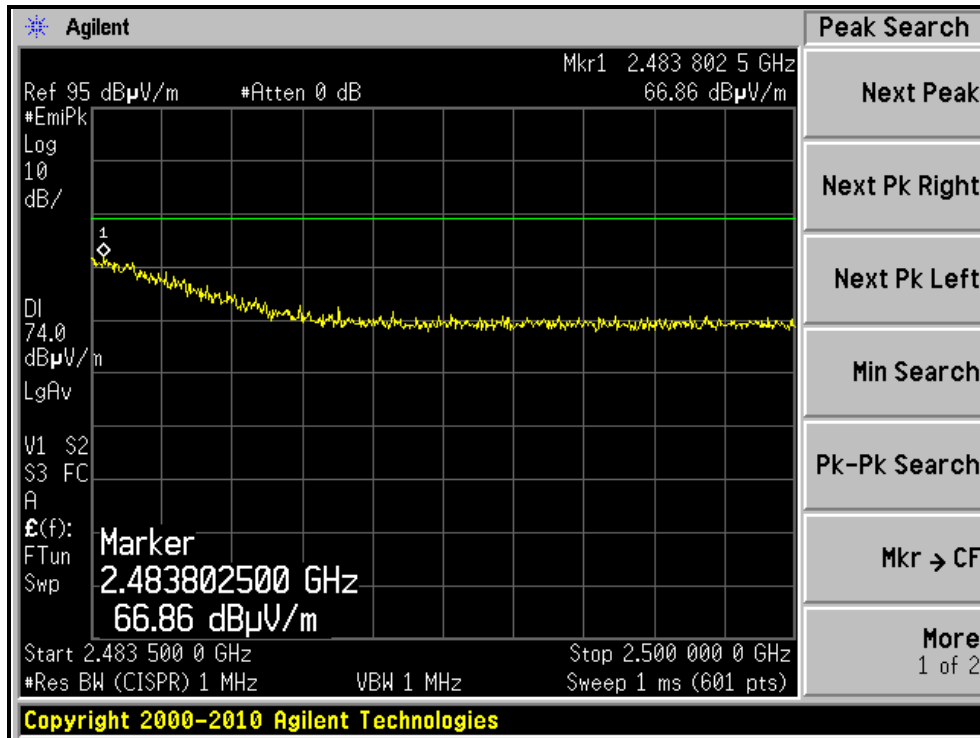

RESTRICTED BANDEDGE (802.11g MODE, CH13, VERTICAL)

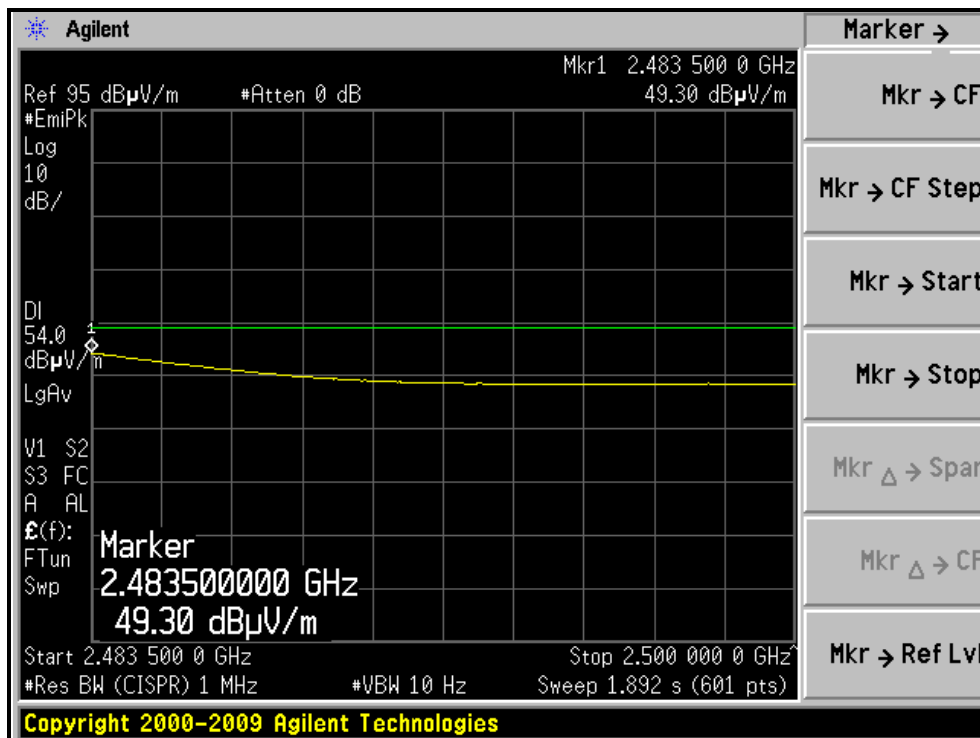
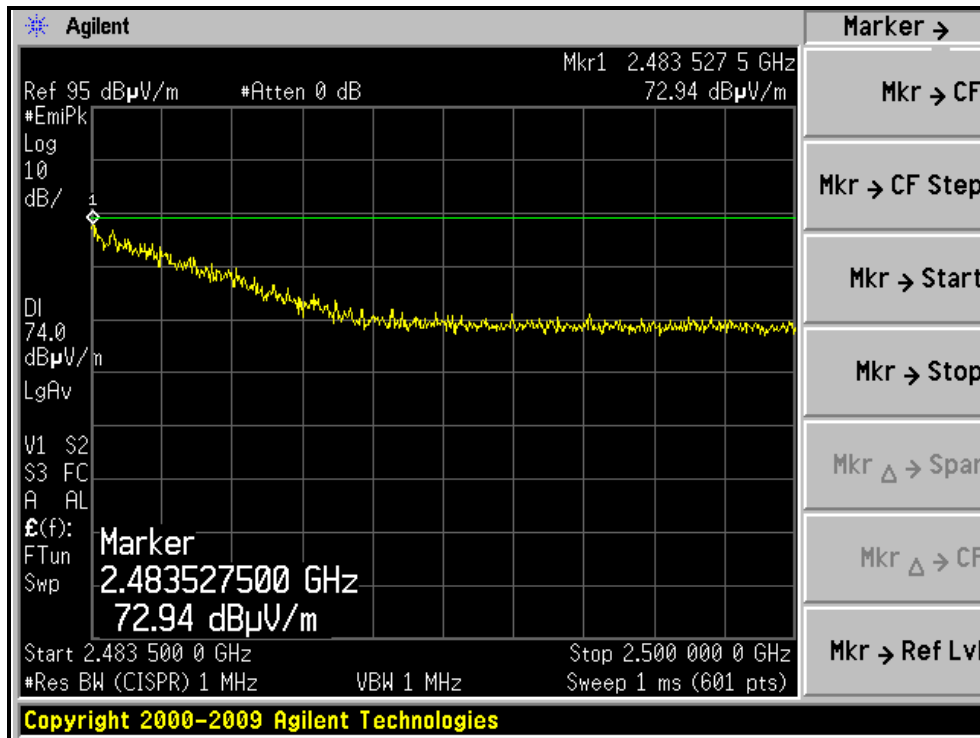



A D T

802.11n (20MHz) OFDM MODULATION

EUT TEST CONDITION		MEASUREMENT DETAIL	
CHANNEL	Channel 1	FREQUENCY RANGE	1 ~ 25GHz
INPUT POWER	DC 3.3V	DETECTOR FUNCTION	Peak (PK) Average (AV)
ENVIRONMENTAL CONDITIONS	19deg. C, 66%RH	TESTED BY	Kent Liu

ANTENNA POLARITY & TEST DISTANCE: HORIZONTAL AT 3 M

NO.	FREQ. (MHz)	EMISSION LEVEL (dBuV/m)	LIMIT (dBuV/m)	MARGIN (dB)	ANTENNA HEIGHT (m)	TABLE ANGLE (Degree)	RAW VALUE (dBuV)	CORRECTION FACTOR (dB/m)
1	2390.00	70.9 PK	74.0	-3.1	1.01 H	88	39.15	31.75
2	2390.00	48.8 AV	54.0	-5.2	1.01 H	88	17.05	31.75
3	*2412.00	105.6 PK			1.00 H	78	73.78	31.82
4	*2412.00	84.8 AV			1.00 H	78	52.98	31.82
5	4824.00	46.0 PK	74.0	-28.0	1.30 H	149	6.64	39.36
6	4824.00	33.8 AV	54.0	-20.2	1.30 H	149	-5.56	39.36

ANTENNA POLARITY & TEST DISTANCE: VERTICAL AT 3 M

NO.	FREQ. (MHz)	EMISSION LEVEL (dBuV/m)	LIMIT (dBuV/m)	MARGIN (dB)	ANTENNA HEIGHT (m)	TABLE ANGLE (Degree)	RAW VALUE (dBuV)	CORRECTION FACTOR (dB/m)
1	2390.00	72.7 PK	74.0	-1.3	1.60 V	296	40.95	31.75
2	2390.00	52.7 AV	54.0	-1.3	1.60 V	296	20.95	31.75
3	*2412.00	110.4 PK			1.55 V	305	78.58	31.82
4	*2412.00	96.0 AV			1.55 V	305	64.18	31.82
5	4824.00	46.2 PK	74.0	-27.8	1.00 V	278	6.84	39.36
6	4824.00	34.5 AV	54.0	-19.5	1.00 V	278	-4.86	39.36

- REMARKS:**
1. Emission level (dBuV/m) = Raw Value (dBuV) + Correction Factor (dB/m).
 2. Correction Factor (dB/m) = Antenna Factor (dB/m) + Cable Factor (dB).
 3. The other emission levels were very low against the limit.
 4. Margin value = Emission level – Limit value.
 5. “ * “: Fundamental frequency.



A D T

EUT TEST CONDITION		MEASUREMENT DETAIL	
CHANNEL	Channel 2	FREQUENCY RANGE	1 ~ 25GHz
INPUT POWER	DC 3.3V	DETECTOR FUNCTION	Peak (PK) Average (AV)
ENVIRONMENTAL CONDITIONS	19deg. C, 66%RH	TESTED BY	Kent Liu

ANTENNA POLARITY & TEST DISTANCE: HORIZONTAL AT 3 M

NO.	FREQ. (MHz)	EMISSION LEVEL (dBuV/m)	LIMIT (dBuV/m)	MARGIN (dB)	ANTENNA HEIGHT (m)	TABLE ANGLE (Degree)	RAW VALUE (dBuV)	CORRECTION FACTOR (dB/m)
1	2390.00	68.4 PK	74.0	-5.6	1.02 H	70	36.65	31.75
2	2390.00	49.0 AV	54.0	-5.0	1.02 H	70	17.25	31.75
3	*2417.00	106.1 PK			1.00 H	68	74.26	31.84
4	*2417.00	85.8 AV			1.00 H	68	53.96	31.84
5	4834.00	46.8 PK	74.0	-27.2	1.24 H	161	7.41	39.39
6	4834.00	34.5 AV	54.0	-19.5	1.24 H	161	-4.89	39.39
7	7251.00	51.0 PK	74.0	-23.0	1.62 H	204	4.08	46.92
8	7251.00	39.8 AV	54.0	-14.2	1.62 H	204	-7.12	46.92

ANTENNA POLARITY & TEST DISTANCE: VERTICAL AT 3 M

NO.	FREQ. (MHz)	EMISSION LEVEL (dBuV/m)	LIMIT (dBuV/m)	MARGIN (dB)	ANTENNA HEIGHT (m)	TABLE ANGLE (Degree)	RAW VALUE (dBuV)	CORRECTION FACTOR (dB/m)
1	2390.00	72.2 PK	74.0	-1.8	1.60 V	296	40.45	31.75
2	2390.00	52.9 AV	54.0	-1.1	1.60 V	296	21.15	31.75
3	*2417.00	112.3 PK			1.50 V	293	80.46	31.84
4	*2417.00	97.0 AV			1.50 V	293	65.16	31.84
5	4834.00	46.5 PK	74.0	-27.5	1.02 V	256	7.11	39.39
6	4834.00	34.9 AV	54.0	-19.1	1.02 V	256	-4.49	39.39
7	7251.00	52.5 PK	74.0	-21.5	1.39 V	83	5.58	46.92
8	7251.00	41.4 AV	54.0	-12.6	1.39 V	83	-5.52	46.92

- REMARKS:**
1. Emission level (dBuV/m) = Raw Value (dBuV) + Correction Factor (dB/m).
 2. Correction Factor (dB/m) = Antenna Factor (dB/m) + Cable Factor (dB).
 3. The other emission levels were very low against the limit.
 4. Margin value = Emission level – Limit value.
 5. “ * “: Fundamental frequency.



A D T

EUT TEST CONDITION		MEASUREMENT DETAIL	
CHANNEL	Channel 3	FREQUENCY RANGE	1 ~ 25GHz
INPUT POWER	DC 3.3V	DETECTOR FUNCTION	Peak (PK) Average (AV)
ENVIRONMENTAL CONDITIONS	19deg. C, 66%RH	TESTED BY	Kent Liu

ANTENNA POLARITY & TEST DISTANCE: HORIZONTAL AT 3 M								
NO.	FREQ. (MHz)	EMISSION LEVEL (dBuV/m)	LIMIT (dBuV/m)	MARGIN (dB)	ANTENNA HEIGHT (m)	TABLE ANGLE (Degree)	RAW VALUE (dBuV)	CORRECTION FACTOR (dB/m)
1	2390.00	67.4 PK	74.0	-6.6	1.42 H	236	35.65	31.75
2	2390.00	49.7 AV	54.0	-4.3	1.42 H	236	17.95	31.75
3	*2422.00	107.4 PK			1.42 H	236	75.54	31.86
4	*2422.00	92.1 AV			1.42 H	236	60.24	31.86
5	4844.00	46.6 PK	74.0	-27.4	1.18 H	148	7.18	39.42
6	4844.00	34.4 AV	54.0	-19.6	1.18 H	148	-5.02	39.42
7	7266.00	52.8 PK	74.0	-21.2	1.58 H	133	5.89	46.91
8	7266.00	42.1 AV	54.0	-11.9	1.58 H	133	-4.81	46.91
ANTENNA POLARITY & TEST DISTANCE: VERTICAL AT 3 M								
NO.	FREQ. (MHz)	EMISSION LEVEL (dBuV/m)	LIMIT (dBuV/m)	MARGIN (dB)	ANTENNA HEIGHT (m)	TABLE ANGLE (Degree)	RAW VALUE (dBuV)	CORRECTION FACTOR (dB/m)
1	2390.00	65.2 PK	74.0	-8.8	1.53 V	252	33.45	31.75
2	2390.00	46.6 AV	54.0	-7.4	1.53 V	252	14.85	31.75
3	*2422.00	113.8 PK			1.53 V	290	81.94	31.86
4	*2422.00	98.6 AV			1.53 V	290	66.74	31.86
5	4844.00	46.9 PK	74.0	-27.1	1.00 V	281	7.48	39.42
6	4844.00	34.9 AV	54.0	-19.1	1.00 V	281	-4.52	39.42
7	7266.00	53.8 PK	74.0	-20.2	1.51 V	91	6.89	46.91
8	7266.00	42.2 AV	54.0	-11.8	1.51 V	91	-4.71	46.91

- REMARKS:**
1. Emission level (dBuV/m) = Raw Value (dBuV) + Correction Factor (dB/m).
 2. Correction Factor (dB/m) = Antenna Factor (dB/m) + Cable Factor (dB).
 3. The other emission levels were very low against the limit.
 4. Margin value = Emission level – Limit value.
 5. “ * “: Fundamental frequency.



A D T

EUT TEST CONDITION		MEASUREMENT DETAIL	
CHANNEL	Channel 6	FREQUENCY RANGE	1 ~ 25GHz
INPUT POWER	DC 3.3V	DETECTOR FUNCTION	Peak (PK) Average (AV)
ENVIRONMENTAL CONDITIONS	19deg. C, 66%RH	TESTED BY	Kent Liu

ANTENNA POLARITY & TEST DISTANCE: HORIZONTAL AT 3 M								
NO.	FREQ. (MHz)	EMISSION LEVEL (dBuV/m)	LIMIT (dBuV/m)	MARGIN (dB)	ANTENNA HEIGHT (m)	TABLE ANGLE (Degree)	RAW VALUE (dBuV)	CORRECTION FACTOR (dB/m)
1	*2437.00	108.7 PK			1.10 H	46	76.78	31.92
2	*2437.00	88.0 AV			1.10 H	46	56.08	31.92
3	4874.00	46.3 PK	74.0	-27.7	1.22 H	153	6.80	39.50
4	4874.00	33.7 AV	54.0	-20.3	1.22 H	153	-5.80	39.50
5	7311.00	52.3 PK	74.0	-21.7	1.51 H	107	5.42	46.88
6	7311.00	41.5 AV	54.0	-12.5	1.51 H	107	-5.38	46.88
ANTENNA POLARITY & TEST DISTANCE: VERTICAL AT 3 M								
NO.	FREQ. (MHz)	EMISSION LEVEL (dBuV/m)	LIMIT (dBuV/m)	MARGIN (dB)	ANTENNA HEIGHT (m)	TABLE ANGLE (Degree)	RAW VALUE (dBuV)	CORRECTION FACTOR (dB/m)
1	*2437.00	114.0 PK			1.56 V	281	82.08	31.92
2	*2437.00	98.6 AV			1.56 V	281	66.68	31.92
3	4874.00	47.1 PK	74.0	-26.9	1.00 V	264	7.60	39.50
4	4874.00	35.0 AV	54.0	-19.0	1.00 V	264	-4.50	39.50
5	7311.00	54.3 PK	74.0	-19.7	1.62 V	71	7.42	46.88
6	7311.00	42.9 AV	54.0	-11.1	1.62 V	71	-3.98	46.88

- REMARKS:**
1. Emission level (dBuV/m) = Raw Value (dBuV) + Correction Factor (dB/m).
 2. Correction Factor (dB/m) = Antenna Factor (dB/m) + Cable Factor (dB).
 3. The other emission levels were very low against the limit.
 4. Margin value = Emission level – Limit value.
 5. “ * “: Fundamental frequency.



A D T

EUT TEST CONDITION		MEASUREMENT DETAIL	
CHANNEL	Channel 9	FREQUENCY RANGE	1 ~ 25GHz
INPUT POWER	DC 3.3V	DETECTOR FUNCTION	Peak (PK) Average (AV)
ENVIRONMENTAL CONDITIONS	19deg. C, 66%RH	TESTED BY	Kent Liu

ANTENNA POLARITY & TEST DISTANCE: HORIZONTAL AT 3 M

NO.	FREQ. (MHz)	EMISSION LEVEL (dBuV/m)	LIMIT (dBuV/m)	MARGIN (dB)	ANTENNA HEIGHT (m)	TABLE ANGLE (Degree)	RAW VALUE (dBuV)	CORRECTION FACTOR (dB/m)
1	*2452.00	106.6 PK			1.66 H	230	74.63	31.97
2	*2452.00	91.3 AV			1.66 H	230	59.33	31.97
3	2483.50	66.0 PK	74.0	-8.0	1.66 H	230	33.91	32.09
4	2483.50	46.4 AV	54.0	-7.6	1.66 H	230	14.31	32.09
5	4904.00	46.9 PK	74.0	-27.1	1.20 H	154	7.30	39.60
6	4904.00	34.4 AV	54.0	-19.6	1.20 H	154	-5.20	39.60
7	7356.00	52.0 PK	74.0	-22.0	1.59 H	134	5.17	46.83
8	7356.00	41.2 AV	54.0	-12.8	1.59 H	134	-5.63	46.83

ANTENNA POLARITY & TEST DISTANCE: VERTICAL AT 3 M

NO.	FREQ. (MHz)	EMISSION LEVEL (dBuV/m)	LIMIT (dBuV/m)	MARGIN (dB)	ANTENNA HEIGHT (m)	TABLE ANGLE (Degree)	RAW VALUE (dBuV)	CORRECTION FACTOR (dB/m)
1	*2452.00	113.9 PK			1.53 V	290	81.93	31.97
2	*2452.00	98.7 AV			1.53 V	290	66.73	31.97
3	2483.50	63.6 PK	74.0	-10.4	1.50 V	288	31.51	32.09
4	2483.50	46.4 AV	54.0	-7.6	1.50 V	288	14.31	32.09
5	4904.00	46.4 PK	74.0	-27.6	1.01 V	265	6.80	39.60
6	4904.00	34.3 AV	54.0	-19.7	1.01 V	265	-5.30	39.60
7	7356.00	54.4 PK	74.0	-19.6	1.49 V	104	7.57	46.83
8	7356.00	42.7 AV	54.0	-11.3	1.49 V	104	-4.13	46.83

- REMARKS:**
1. Emission level (dBuV/m) = Raw Value (dBuV) + Correction Factor (dB/m).
 2. Correction Factor (dB/m) = Antenna Factor (dB/m) + Cable Factor (dB).
 3. The other emission levels were very low against the limit.
 4. Margin value = Emission level – Limit value.
 5. “ * “: Fundamental frequency.



A D T

EUT TEST CONDITION		MEASUREMENT DETAIL	
CHANNEL	Channel 10	FREQUENCY RANGE	1 ~ 25GHz
INPUT POWER	DC 3.3V	DETECTOR FUNCTION	Peak (PK) Average (AV)
ENVIRONMENTAL CONDITIONS	19deg. C, 66%RH	TESTED BY	Kent Liu

ANTENNA POLARITY & TEST DISTANCE: HORIZONTAL AT 3 M

NO.	FREQ. (MHz)	EMISSION LEVEL (dBuV/m)	LIMIT (dBuV/m)	MARGIN (dB)	ANTENNA HEIGHT (m)	TABLE ANGLE (Degree)	RAW VALUE (dBuV)	CORRECTION FACTOR (dB/m)
1	*2457.00	107.5 PK			1.05 H	62	75.51	31.99
2	*2457.00	86.4 AV			1.05 H	62	54.41	31.99
3	2483.50	68.9 PK	74.0	-5.1	1.06 H	67	36.81	32.09
4	2483.50	48.0 AV	54.0	-6.0	1.06 H	67	15.91	32.09
5	4914.00	46.7 PK	74.0	-27.3	1.19 H	148	7.07	39.63
6	4914.00	34.5 AV	54.0	-19.5	1.19 H	148	-5.13	39.63
7	7371.00	51.9 PK	74.0	-22.1	1.63 H	134	5.09	46.81
8	7371.00	41.0 AV	54.0	-13.0	1.63 H	134	-5.81	46.81

ANTENNA POLARITY & TEST DISTANCE: VERTICAL AT 3 M

NO.	FREQ. (MHz)	EMISSION LEVEL (dBuV/m)	LIMIT (dBuV/m)	MARGIN (dB)	ANTENNA HEIGHT (m)	TABLE ANGLE (Degree)	RAW VALUE (dBuV)	CORRECTION FACTOR (dB/m)
1	*2457.00	112.5 PK			1.45 V	295	80.51	31.99
2	*2457.00	97.2 AV			1.45 V	295	65.21	31.99
3	2483.50	72.5 PK	74.0	-1.5	1.44 V	294	40.41	32.09
4	2483.50	52.9 AV	54.0	-1.1	1.44 V	294	20.81	32.09
5	4914.00	46.2 PK	74.0	-27.8	1.06 V	277	6.57	39.63
6	4914.00	34.4 AV	54.0	-19.6	1.06 V	277	-5.23	39.63
7	7371.00	54.2 PK	74.0	-19.8	1.57 V	92	7.39	46.81
8	7371.00	42.5 AV	54.0	-11.5	1.57 V	92	-4.31	46.81

- REMARKS:**
1. Emission level (dBuV/m) = Raw Value (dBuV) + Correction Factor (dB/m).
 2. Correction Factor (dB/m) = Antenna Factor (dB/m) + Cable Factor (dB).
 3. The other emission levels were very low against the limit.
 4. Margin value = Emission level – Limit value.
 5. “ * “: Fundamental frequency.



A D T

EUT TEST CONDITION		MEASUREMENT DETAIL	
CHANNEL	Channel 11	FREQUENCY RANGE	1 ~ 25GHz
INPUT POWER	DC 3.3V	DETECTOR FUNCTION	Peak (PK) Average (AV)
ENVIRONMENTAL CONDITIONS	19deg. C, 66%RH	TESTED BY	Kent Liu

ANTENNA POLARITY & TEST DISTANCE: HORIZONTAL AT 3 M

NO.	FREQ. (MHz)	EMISSION LEVEL (dBuV/m)	LIMIT (dBuV/m)	MARGIN (dB)	ANTENNA HEIGHT (m)	TABLE ANGLE (Degree)	RAW VALUE (dBuV)	CORRECTION FACTOR (dB/m)
1	*2462.00	104.5 PK			1.01 H	64	72.49	32.01
2	*2462.00	84.0 AV			1.01 H	64	51.99	32.01
3	2483.50	66.8 PK	74.0	-7.2	1.01 H	65	34.71	32.09
4	2483.50	46.4 AV	54.0	-7.6	1.01 H	65	14.31	32.09
5	4924.00	46.5 PK	74.0	-27.5	1.22 H	144	6.83	39.67
6	4924.00	34.3 AV	54.0	-19.7	1.22 H	144	-5.37	39.67
7	7386.00	51.6 PK	74.0	-22.4	1.58 H	208	4.80	46.80
8	7386.00	40.2 AV	54.0	-13.8	1.58 H	208	-6.60	46.80

ANTENNA POLARITY & TEST DISTANCE: VERTICAL AT 3 M

NO.	FREQ. (MHz)	EMISSION LEVEL (dBuV/m)	LIMIT (dBuV/m)	MARGIN (dB)	ANTENNA HEIGHT (m)	TABLE ANGLE (Degree)	RAW VALUE (dBuV)	CORRECTION FACTOR (dB/m)
1	*2462.00	109.9 PK			1.45 V	295	77.89	32.01
2	*2462.00	94.6 AV			1.45 V	295	62.59	32.01
3	2483.50	72.7 PK	74.0	-1.3	1.45 V	295	40.61	32.09
4	2483.50	50.6 AV	54.0	-3.4	1.45 V	295	18.51	32.09
5	4924.00	46.2 PK	74.0	-27.8	1.01 V	266	6.53	39.67
6	4924.00	34.6 AV	54.0	-19.4	1.01 V	266	-5.07	39.67
7	7386.00	53.8 PK	74.0	-20.2	1.54 V	71	7.00	46.80
8	7386.00	42.0 AV	54.0	-12.0	1.54 V	71	-4.80	46.80

- REMARKS:**
1. Emission level (dBuV/m) = Raw Value (dBuV) + Correction Factor (dB/m).
 2. Correction Factor (dB/m) = Antenna Factor (dB/m) + Cable Factor (dB).
 3. The other emission levels were very low against the limit.
 4. Margin value = Emission level – Limit value.
 5. “ * “: Fundamental frequency.



A D T

EUT TEST CONDITION		MEASUREMENT DETAIL	
CHANNEL	Channel 12	FREQUENCY RANGE	1 ~ 25GHz
INPUT POWER	DC 3.3V	DETECTOR FUNCTION	Peak (PK) Average (AV)
ENVIRONMENTAL CONDITIONS	19deg. C, 66%RH	TESTED BY	Kent Liu

ANTENNA POLARITY & TEST DISTANCE: HORIZONTAL AT 3 M								
NO.	FREQ. (MHz)	EMISSION LEVEL (dBuV/m)	LIMIT (dBuV/m)	MARGIN (dB)	ANTENNA HEIGHT (m)	TABLE ANGLE (Degree)	RAW VALUE (dBuV)	CORRECTION FACTOR (dB/m)
1	*2467.00	101.8 PK			1.06 H	55	69.77	32.03
2	*2467.00	82.1 AV			1.06 H	55	50.07	32.03
3	2483.50	66.8 PK	74.0	-7.2	1.05 H	48	34.71	32.09
4	2483.50	48.2 AV	54.0	-5.8	1.05 H	48	16.11	32.09
5	4934.00	45.9 PK	74.0	-28.1	1.18 H	160	6.19	39.71
6	4934.00	33.8 AV	54.0	-20.2	1.18 H	160	-5.91	39.71
7	7401.00	51.9 PK	74.0	-22.1	1.53 H	237	5.12	46.78
8	7401.00	40.7 AV	54.0	-13.3	1.53 H	237	-6.08	46.78
ANTENNA POLARITY & TEST DISTANCE: VERTICAL AT 3 M								
NO.	FREQ. (MHz)	EMISSION LEVEL (dBuV/m)	LIMIT (dBuV/m)	MARGIN (dB)	ANTENNA HEIGHT (m)	TABLE ANGLE (Degree)	RAW VALUE (dBuV)	CORRECTION FACTOR (dB/m)
1	*2467.00	107.6 PK			1.45 V	298	75.57	32.03
2	*2467.00	92.8 AV			1.45 V	298	60.77	32.03
3	2483.50	72.7 PK	74.0	-1.3	1.45 V	299	40.61	32.09
4	2483.50	52.9 AV	54.0	-1.1	1.45 V	299	20.81	32.09
5	4934.00	46.1 PK	74.0	-27.9	1.00 V	292	6.39	39.71
6	4934.00	34.4 AV	54.0	-19.6	1.00 V	292	-5.31	39.71
7	7401.00	53.1 PK	74.0	-20.9	1.43 V	85	6.32	46.78
8	7401.00	41.8 AV	54.0	-12.2	1.43 V	85	-4.98	46.78

- REMARKS:**
1. Emission level (dBuV/m) = Raw Value (dBuV) + Correction Factor (dB/m).
 2. Correction Factor (dB/m) = Antenna Factor (dB/m) + Cable Factor (dB).
 3. The other emission levels were very low against the limit.
 4. Margin value = Emission level – Limit value.
 5. “ * “: Fundamental frequency.



A D T

EUT TEST CONDITION		MEASUREMENT DETAIL	
CHANNEL	Channel 13	FREQUENCY RANGE	1 ~ 25GHz
INPUT POWERF	DC 3.3V	DETECTOR FUNCTION	Peak (PK) Average (AV)
ENVIRONMENTAL CONDITIONS	19deg. C, 66%RH	TESTED BY	Kent Liu

ANTENNA POLARITY & TEST DISTANCE: HORIZONTAL AT 3 M

NO.	FREQ. (MHz)	EMISSION LEVEL (dBuV/m)	LIMIT (dBuV/m)	MARGIN (dB)	ANTENNA HEIGHT (m)	TABLE ANGLE (Degree)	RAW VALUE (dBuV)	CORRECTION FACTOR (dB/m)
1	*2472.00	90.0 PK			1.03 H	53	57.95	32.05
2	*2472.00	72.8 AV			1.03 H	53	40.75	32.05
3	2483.50	69.2 PK	74.0	-4.8	1.04 H	50	37.11	32.09
4	2483.50	46.7 AV	54.0	-7.3	1.04 H	50	14.61	32.09
5	4944.00	46.4 PK	74.0	-27.6	1.23 H	151	6.65	39.75
6	4944.00	34.0 AV	54.0	-20.0	1.23 H	151	-5.75	39.75
7	7416.00	51.3 PK	74.0	-22.7	1.62 H	206	4.53	46.77
8	7416.00	39.8 AV	54.0	-14.2	1.62 H	206	-6.97	46.77

ANTENNA POLARITY & TEST DISTANCE: VERTICAL AT 3 M

NO.	FREQ. (MHz)	EMISSION LEVEL (dBuV/m)	LIMIT (dBuV/m)	MARGIN (dB)	ANTENNA HEIGHT (m)	TABLE ANGLE (Degree)	RAW VALUE (dBuV)	CORRECTION FACTOR (dB/m)
1	*2472.00	95.4 PK			1.45 V	296	63.35	32.05
2	*2472.00	81.7 AV			1.45 V	296	49.65	32.05
3	2483.50	72.9 PK	74.0	-1.1	1.45 V	296	40.81	32.09
4	2483.50	49.5 AV	54.0	-4.5	1.45 V	296	17.41	32.09
5	4944.00	45.6 PK	74.0	-28.4	1.00 V	286	5.85	39.75
6	4944.00	34.4 AV	54.0	-19.6	1.00 V	286	-5.35	39.75
7	7416.00	52.8 PK	74.0	-21.2	1.42 V	71	6.03	46.77
8	7416.00	41.8 AV	54.0	-12.2	1.42 V	71	-4.97	46.77

- REMARKS:**
1. Emission level (dBuV/m) = Raw Value (dBuV) + Correction Factor (dB/m).
 2. Correction Factor (dB/m) = Antenna Factor (dB/m) + Cable Factor (dB).
 3. The other emission levels were very low against the limit.
 4. Margin value = Emission level – Limit value.
 5. “ * “: Fundamental frequency.



A D T

RESTRICTED BANDEDGE (802.11n (20MHz) MODE,CH1, HORIZONTAL)

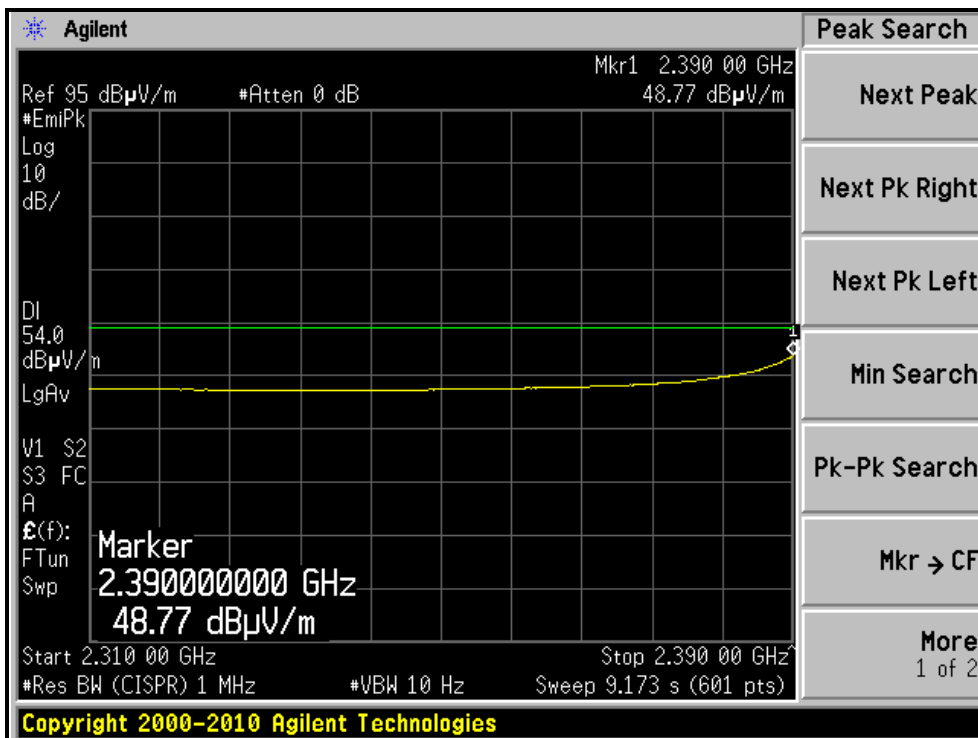
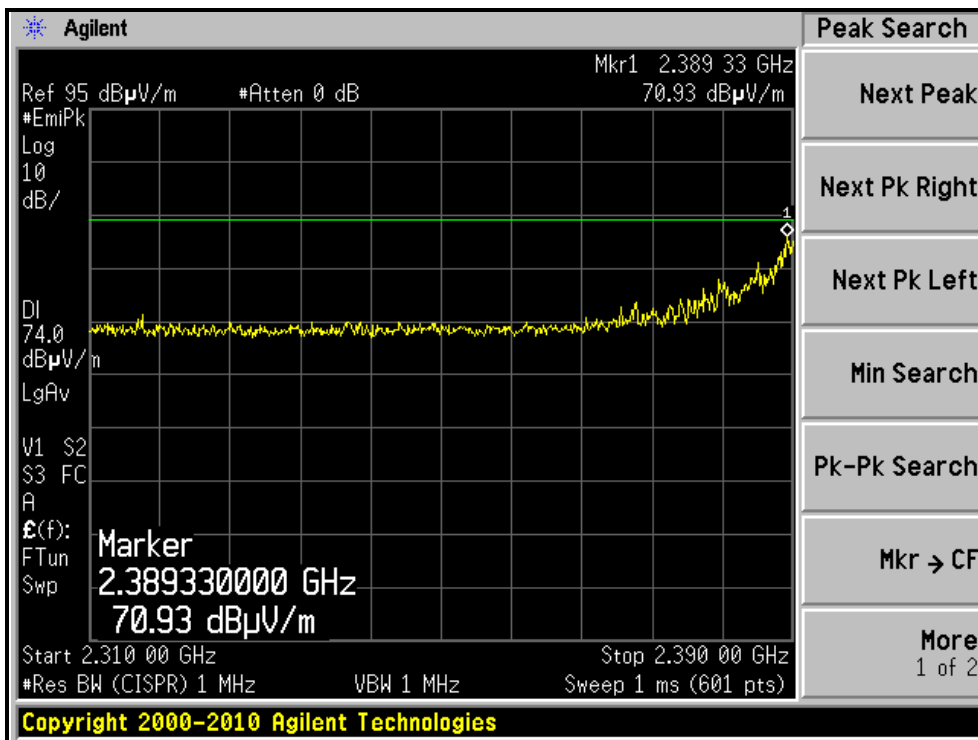

RESTRICTED BANDEDGE (802.11n (20MHz) MODE,CH1, VERTICAL)

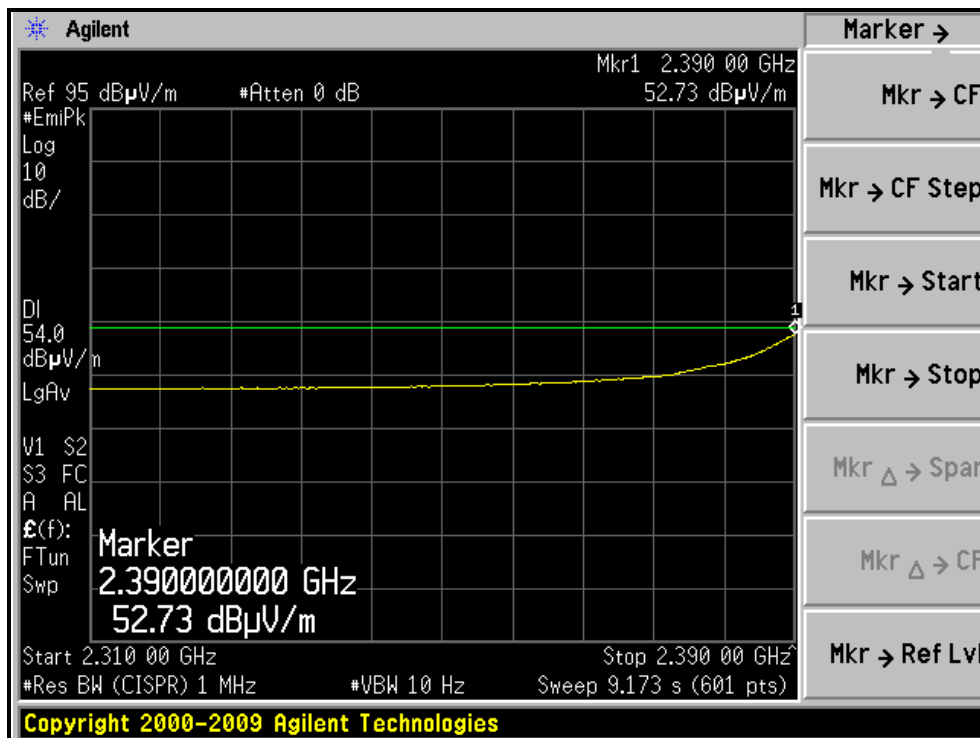
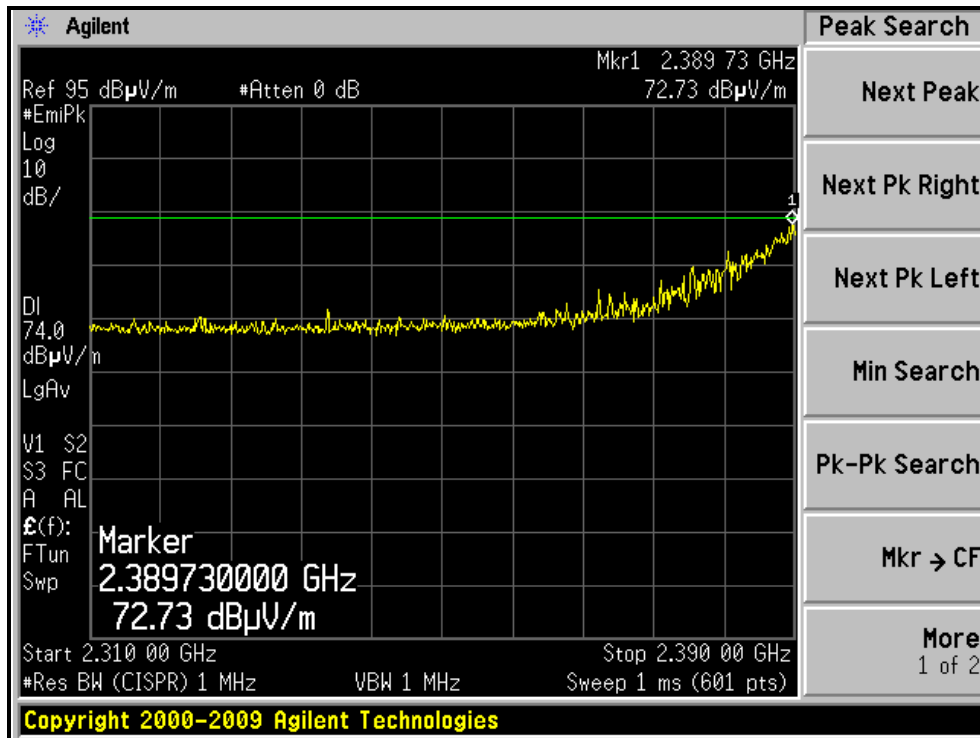

RESTRICTED BANDEDGE (802.11n (20MHz) MODE,CH2, HORIZONTAL)

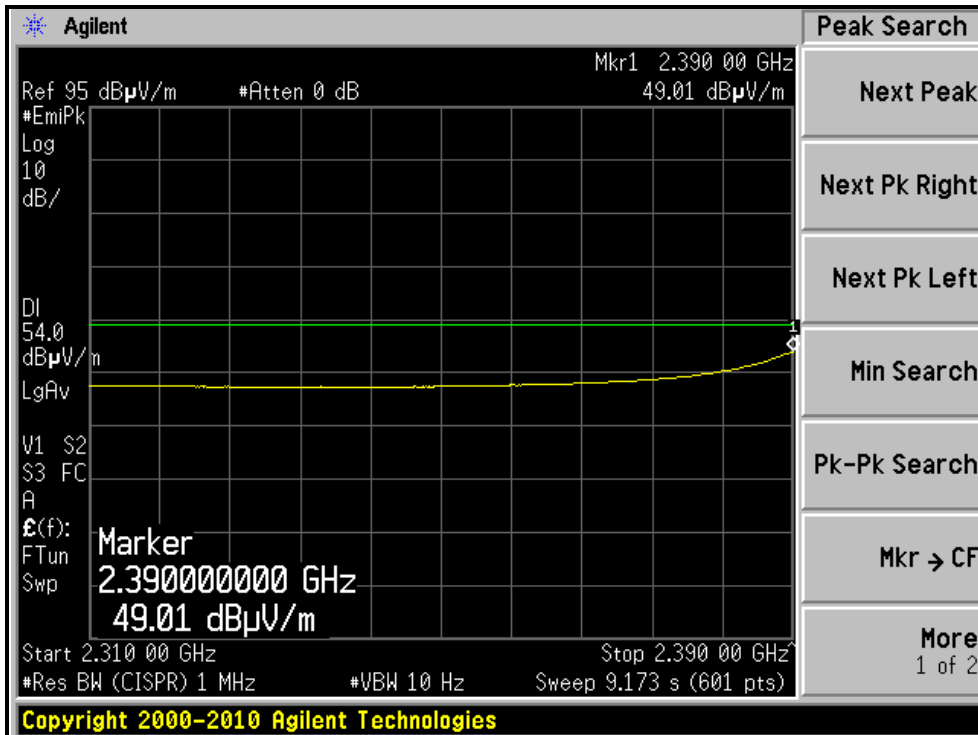
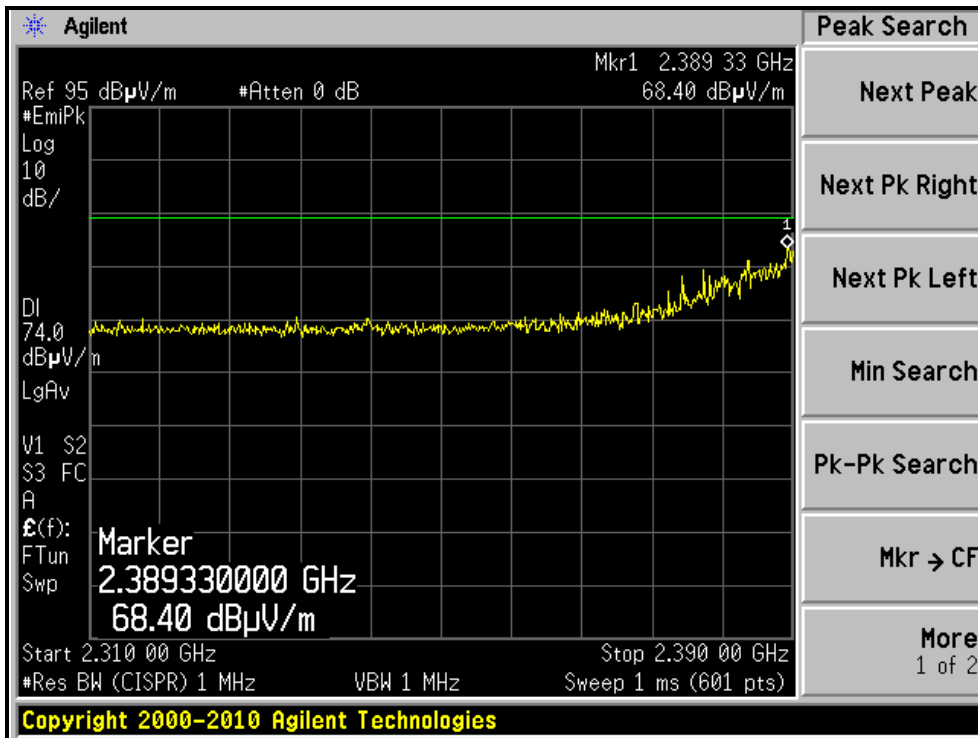

RESTRICTED BANDEDGE (802.11n (20MHz) MODE,CH2, VERTICAL)

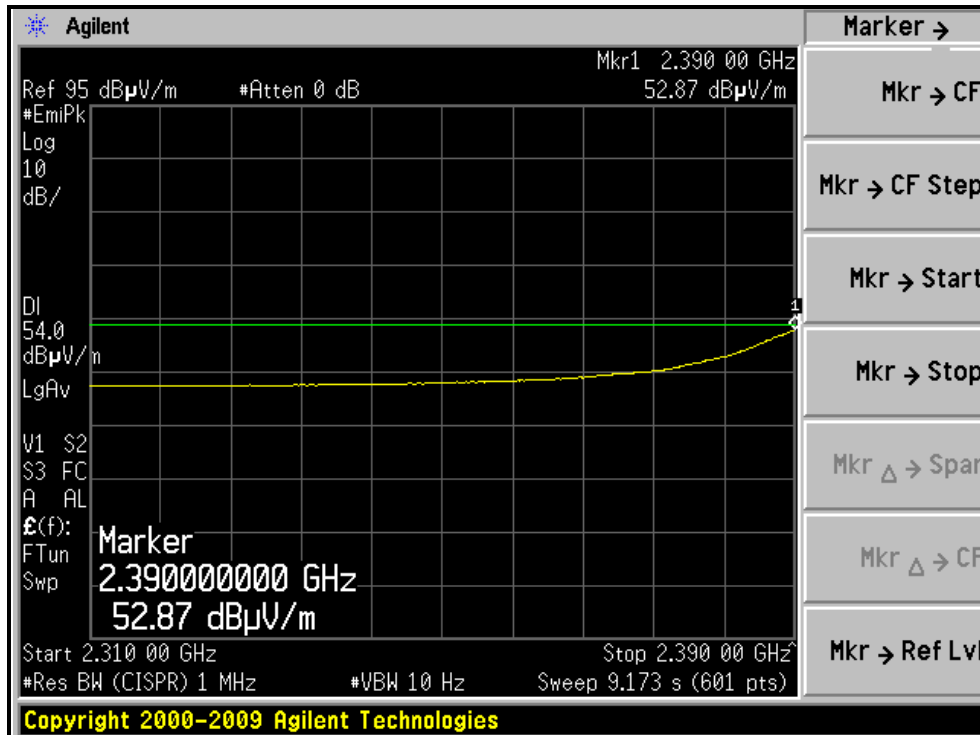
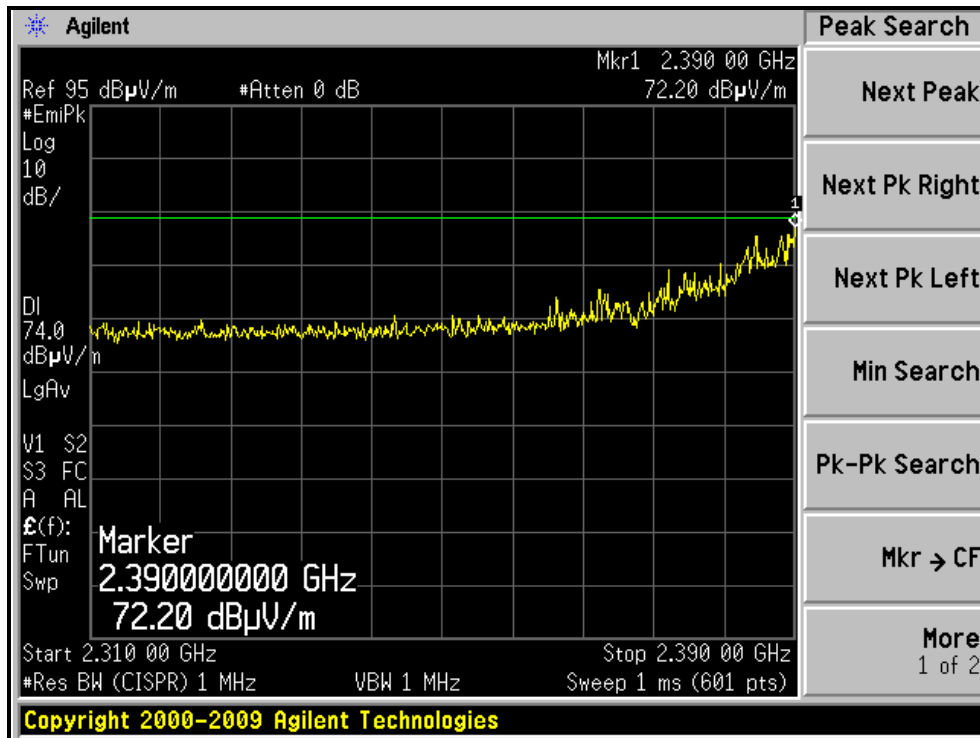

RESTRICTED BANDEDGE (802.11n (20MHz) MODE,CH3, HORIZONTAL)

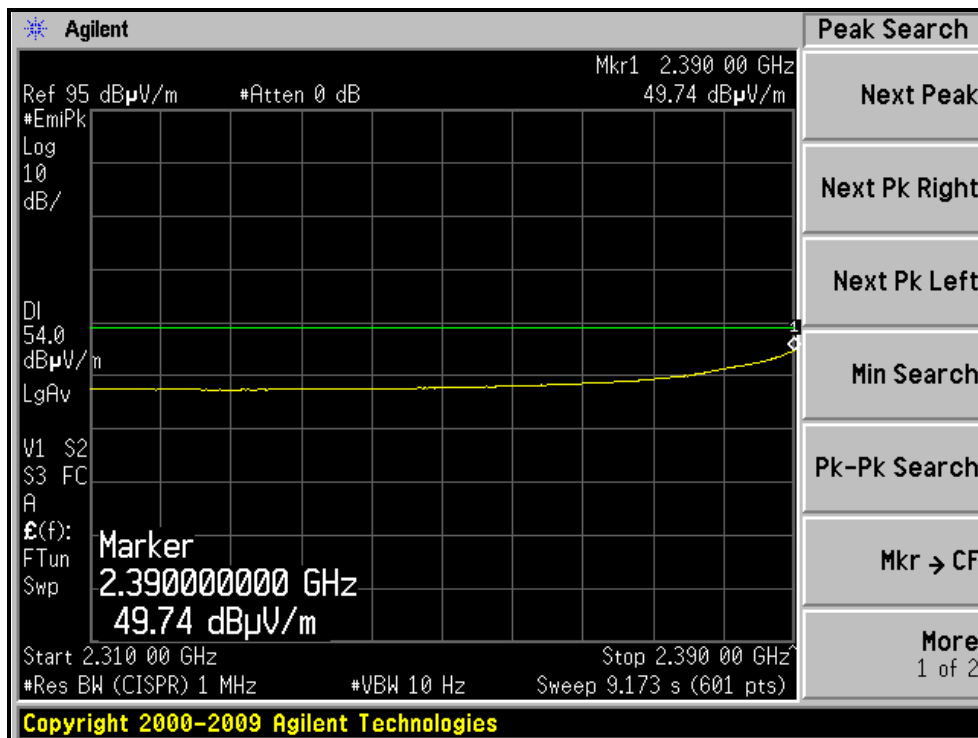
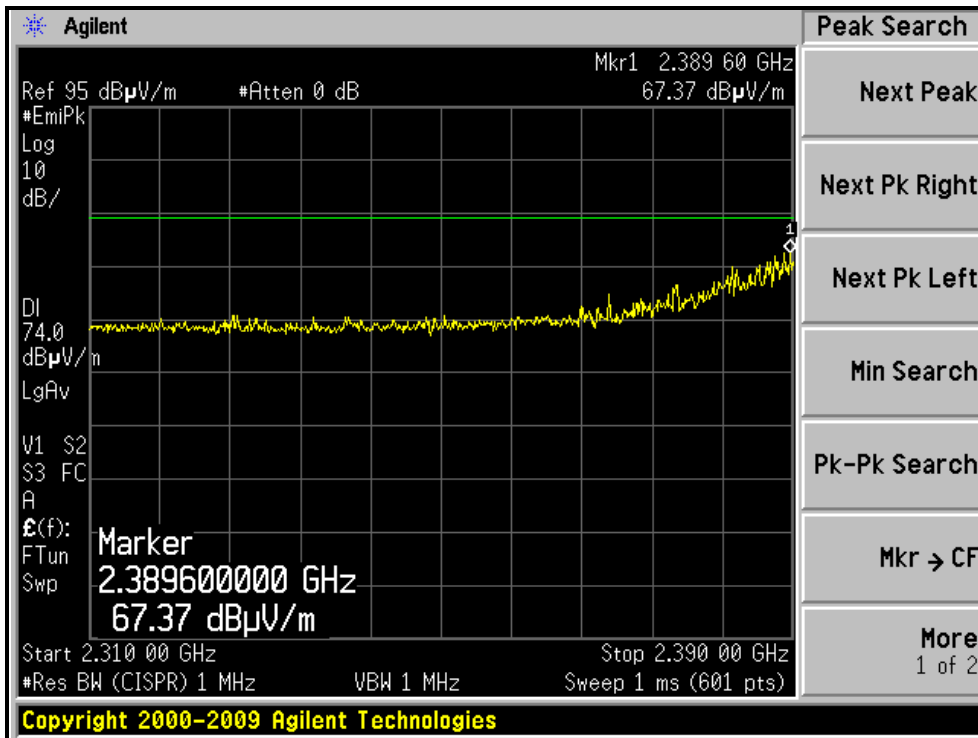

RESTRICTED BANDEDGE (802.11n (20MHz) MODE,CH3, VERTICAL)

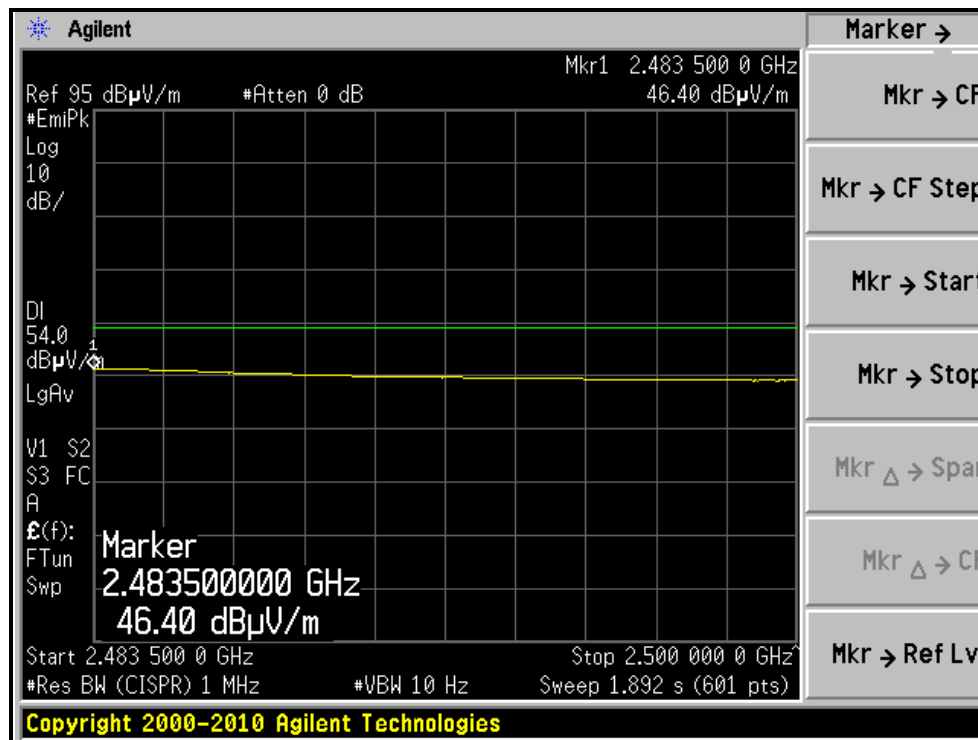
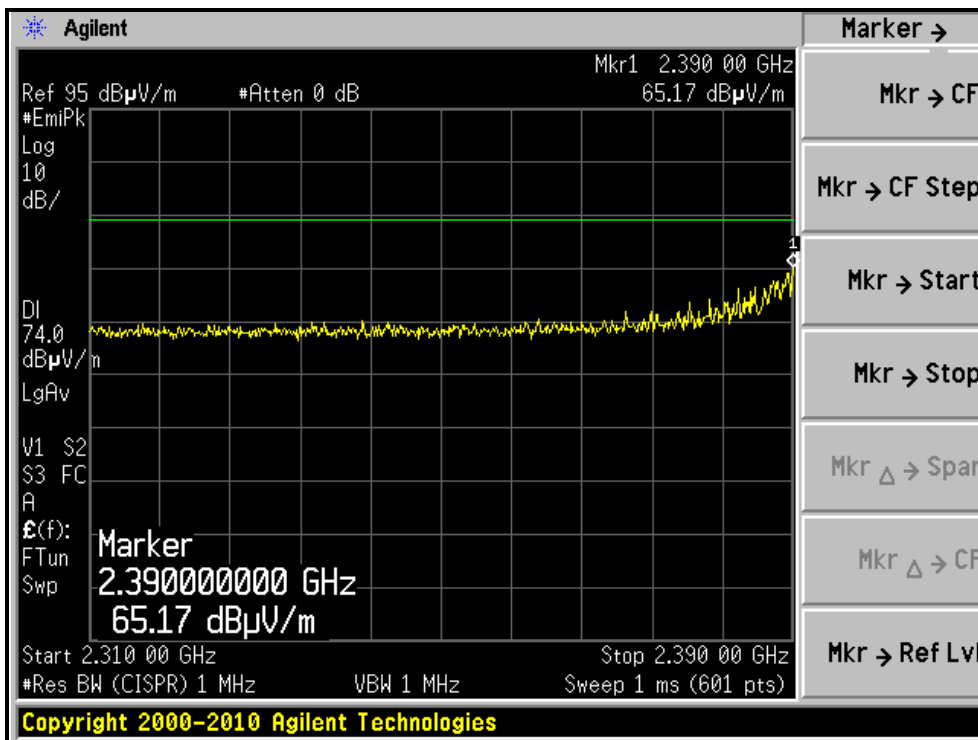

RESTRICTED BANDEDGE (802.11n (20MHz) MODE,CH9, HORIZONTAL)

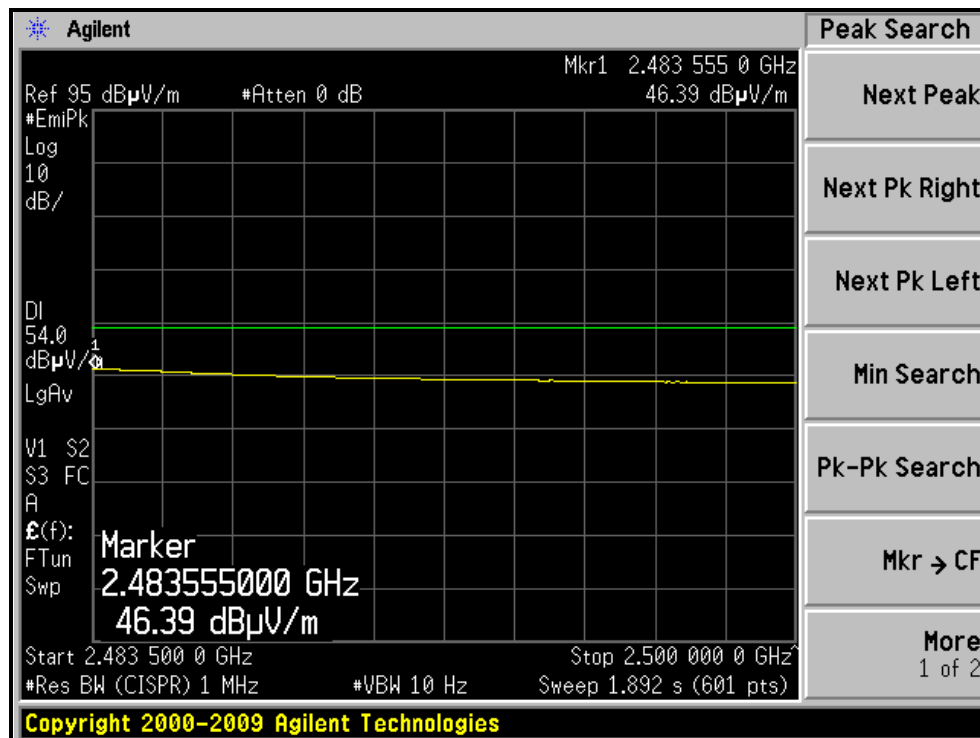
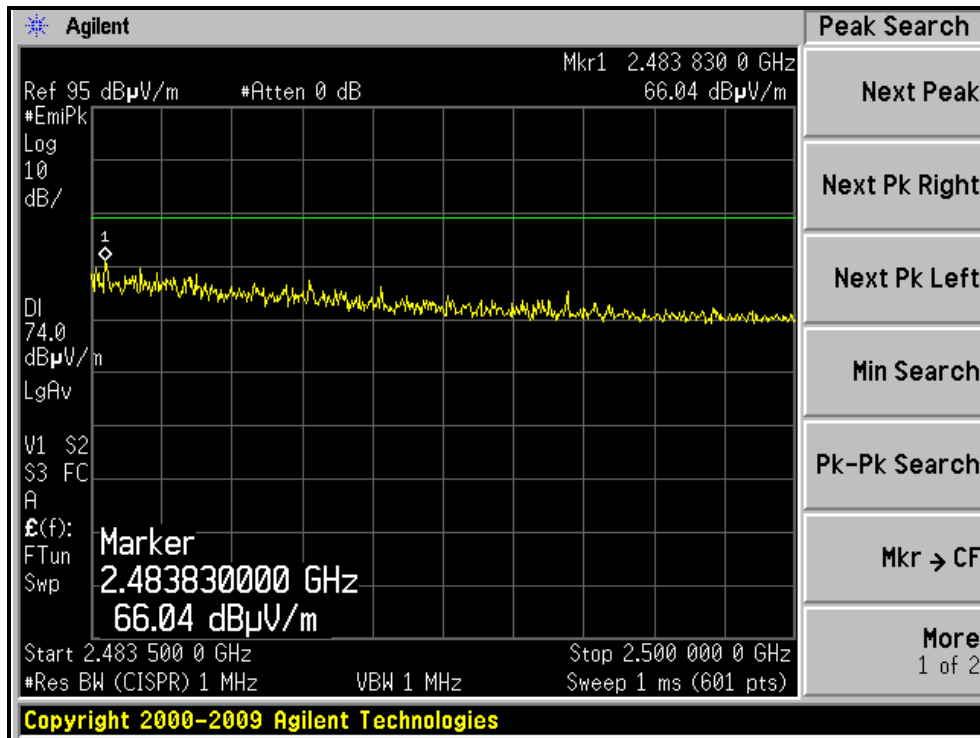

RESTRICTED BANDEDGE (802.11n (20MHz) MODE,CH9, VERTICAL)

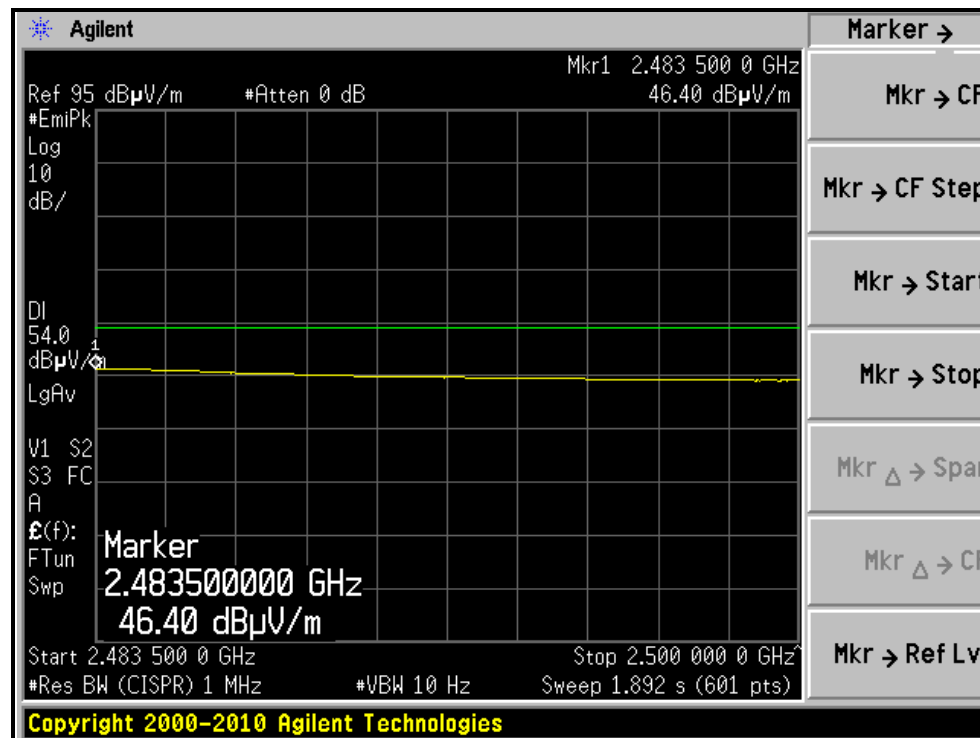
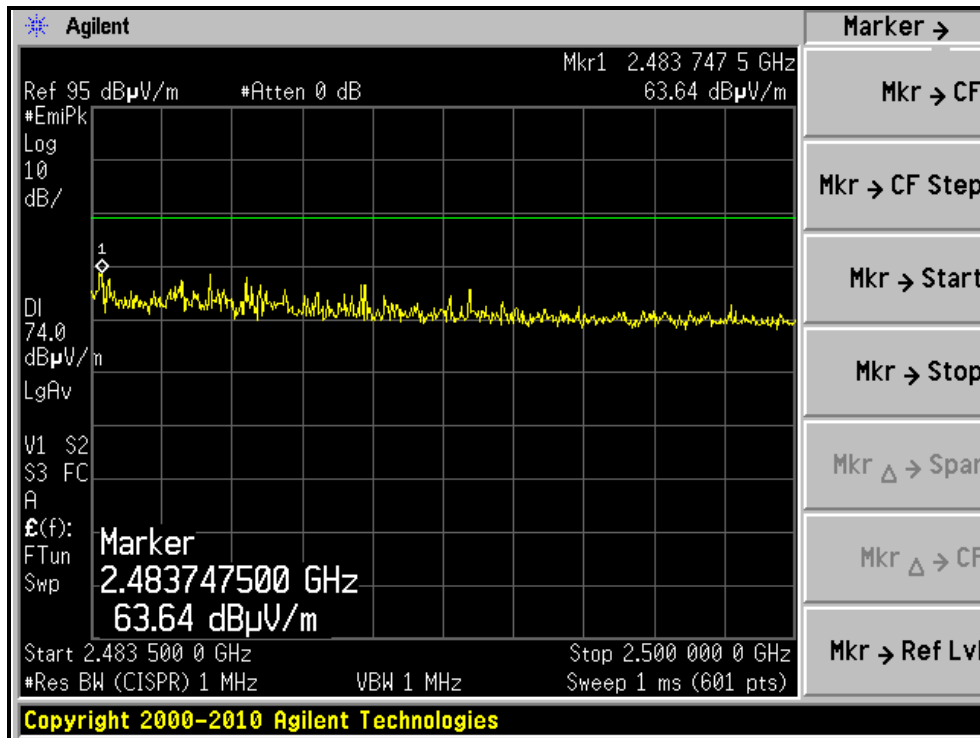



A D T

RESTRICTED BANDEDGE (802.11n (20MHz) MODE,CH10, HORIZONTAL)

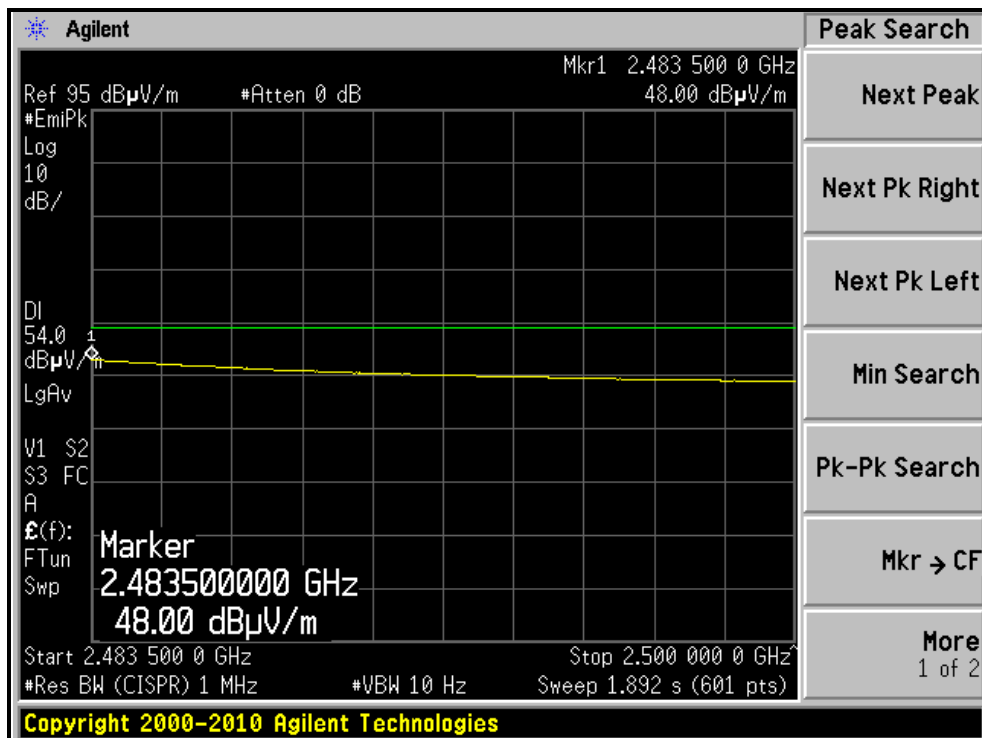
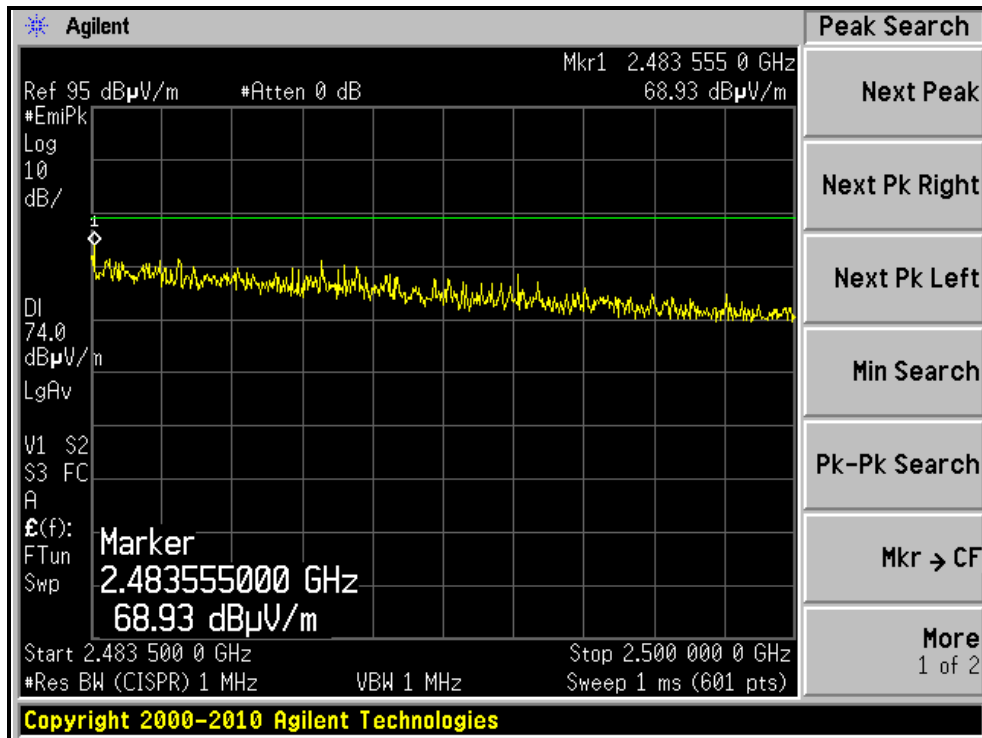

RESTRICTED BANDEDGE (802.11n (20MHz) MODE,CH10, VERTICAL)

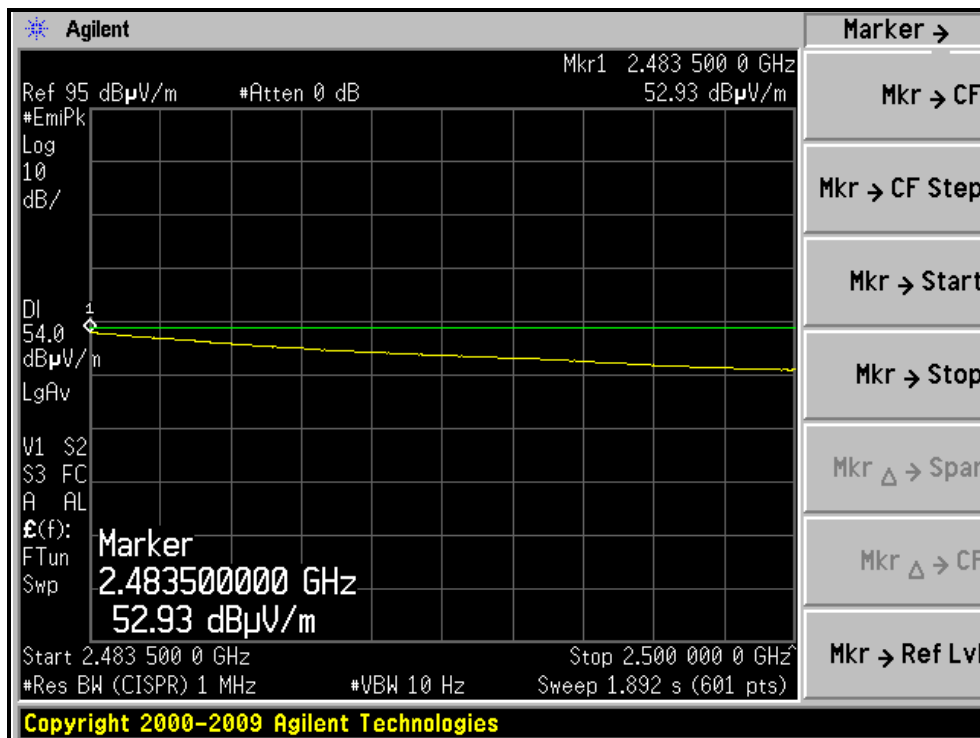
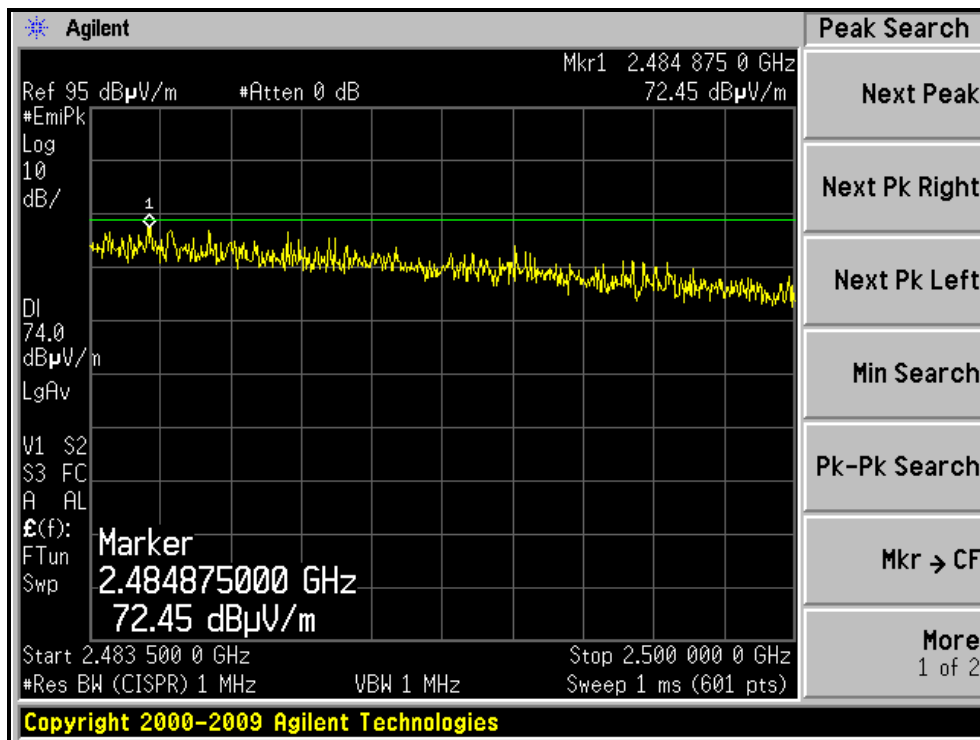



A D T

RESTRICTED BANDEDGE (802.11n (20MHz) MODE,CH11, HORIZONTAL)

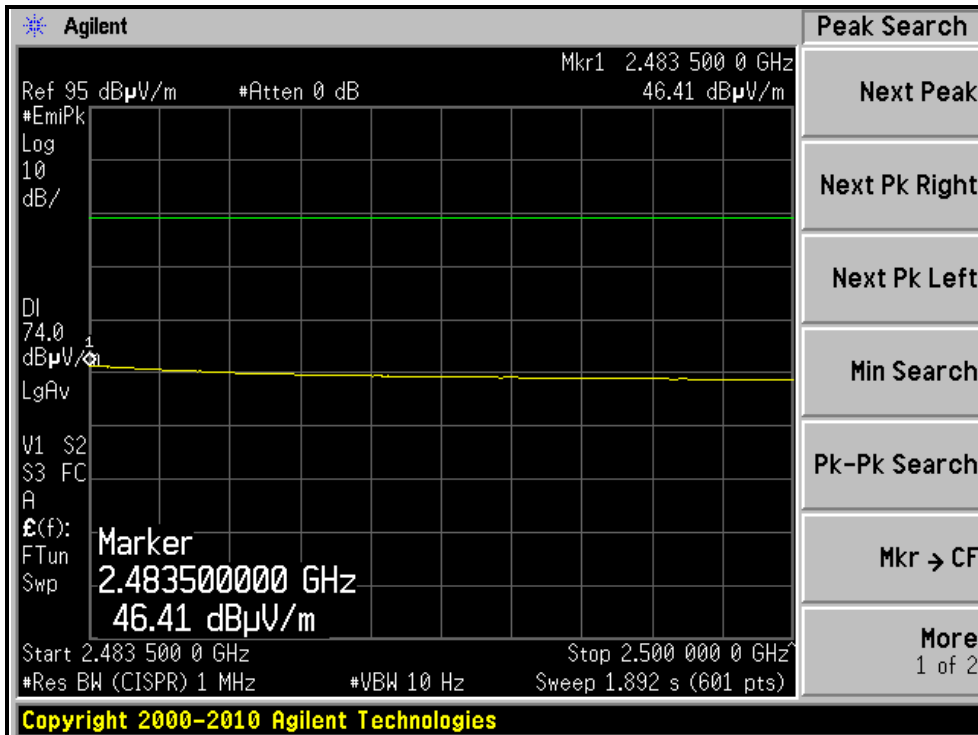
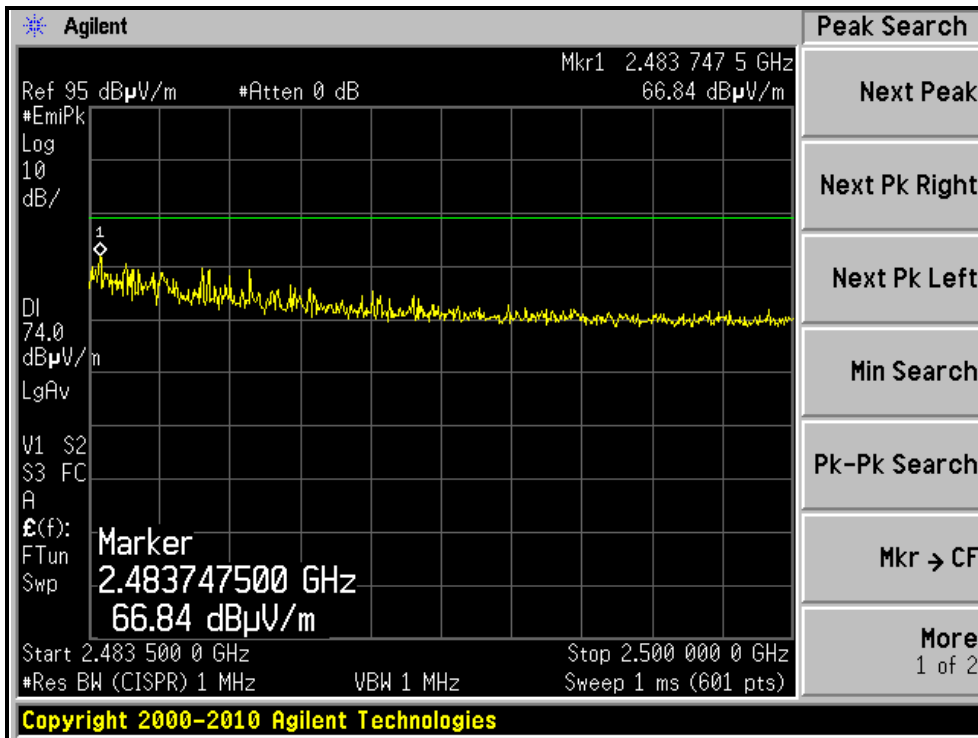

RESTRICTED BANDEDGE (802.11n (20MHz) MODE,CH11, VERTICAL)

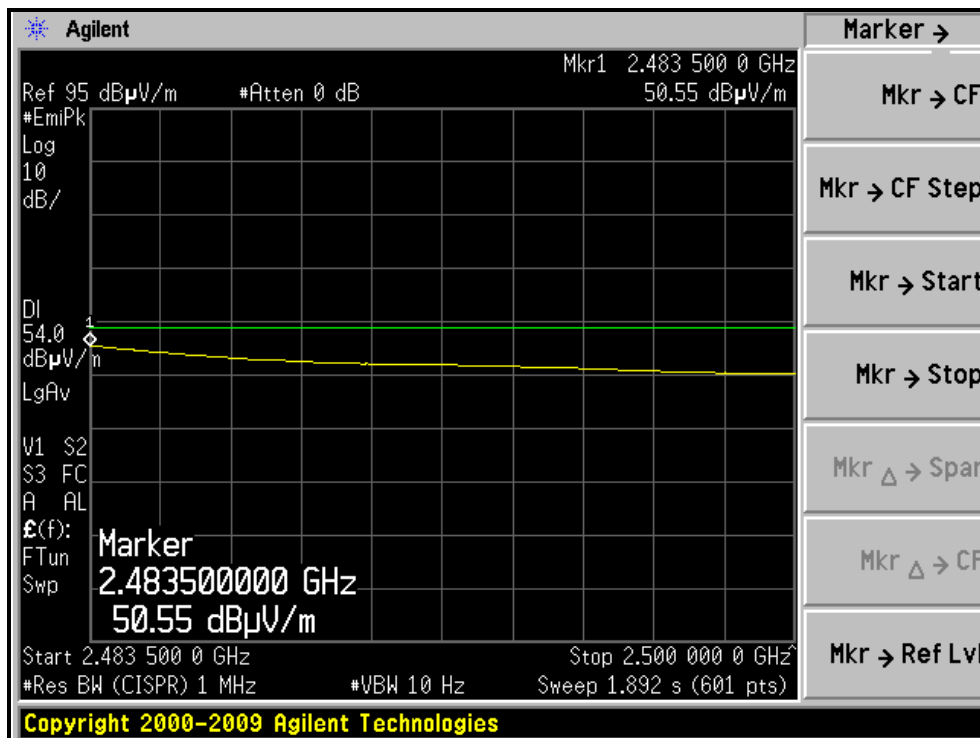
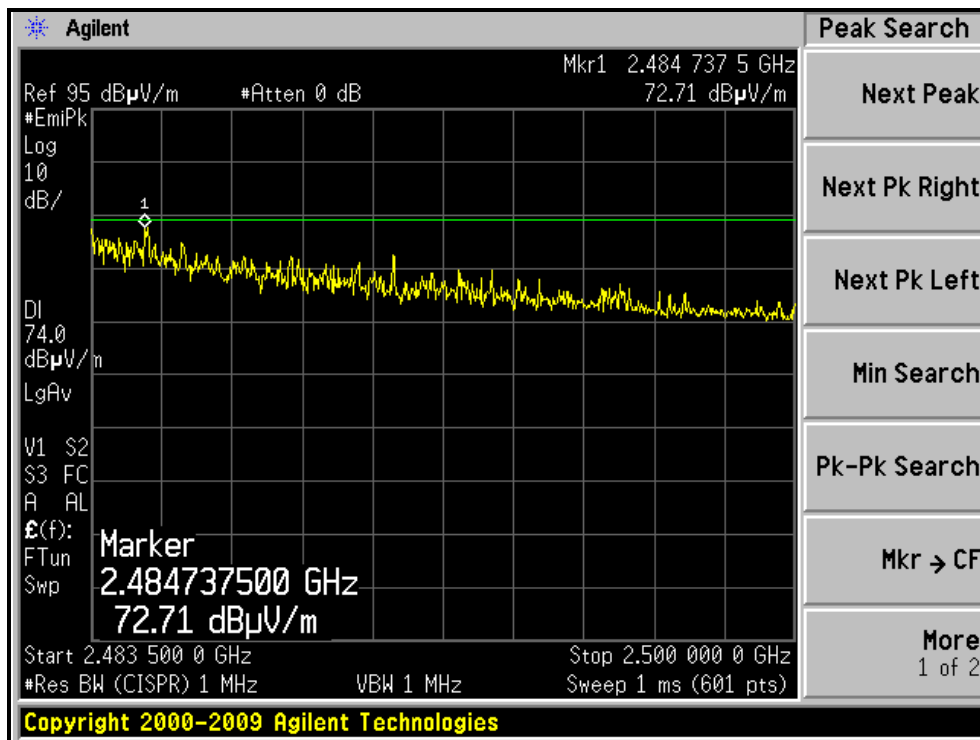

RESTRICTED BANDEDGE (802.11n (20MHz) MODE,CH12, HORIZONTAL)

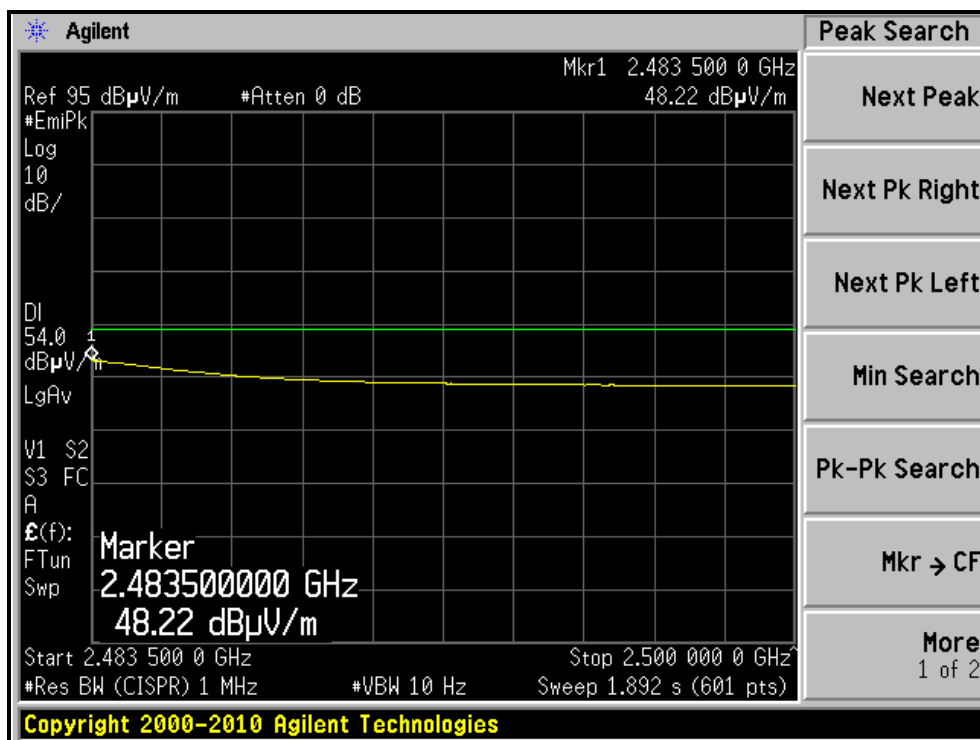
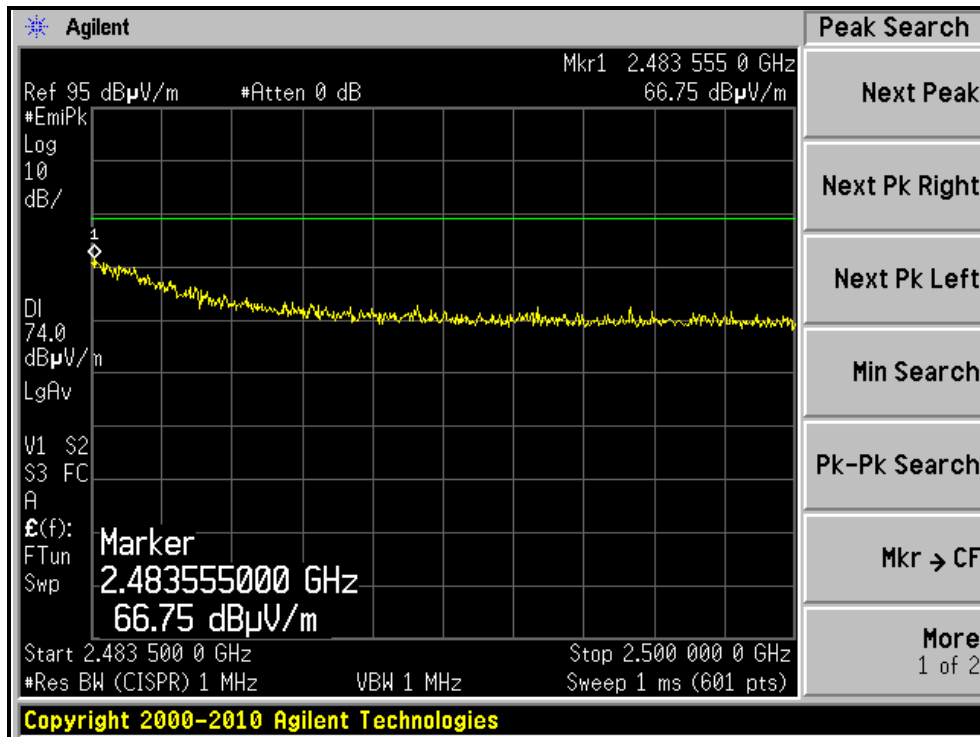



A D T

RESTRICTED BANDEDGE (802.11n (20MHz) MODE,CH12, VERTICAL)

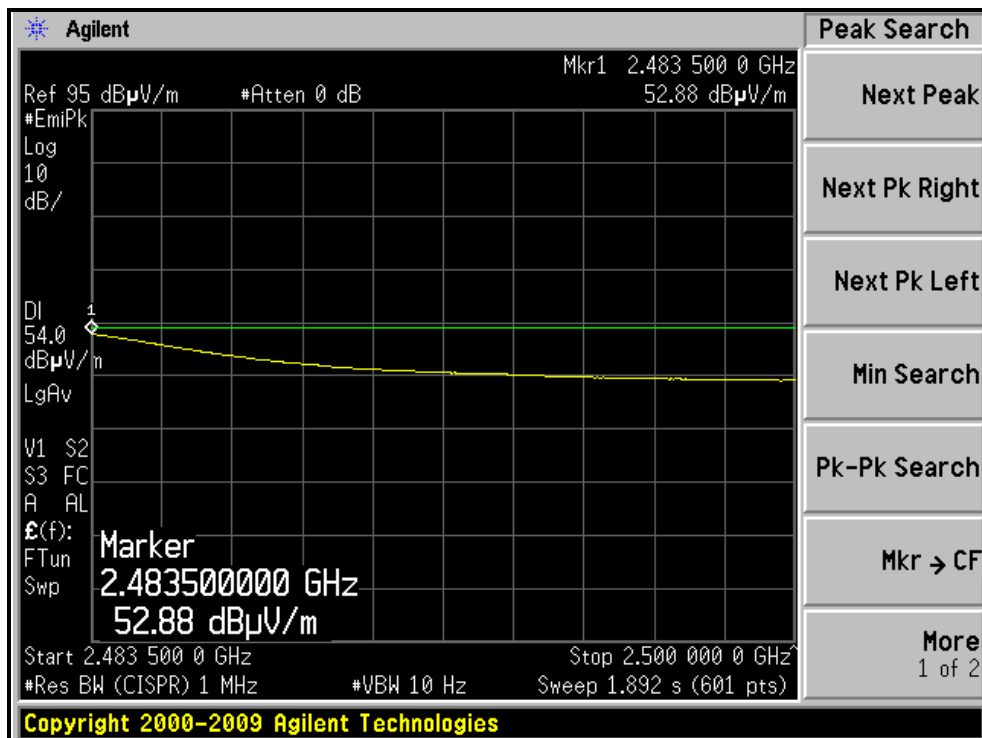
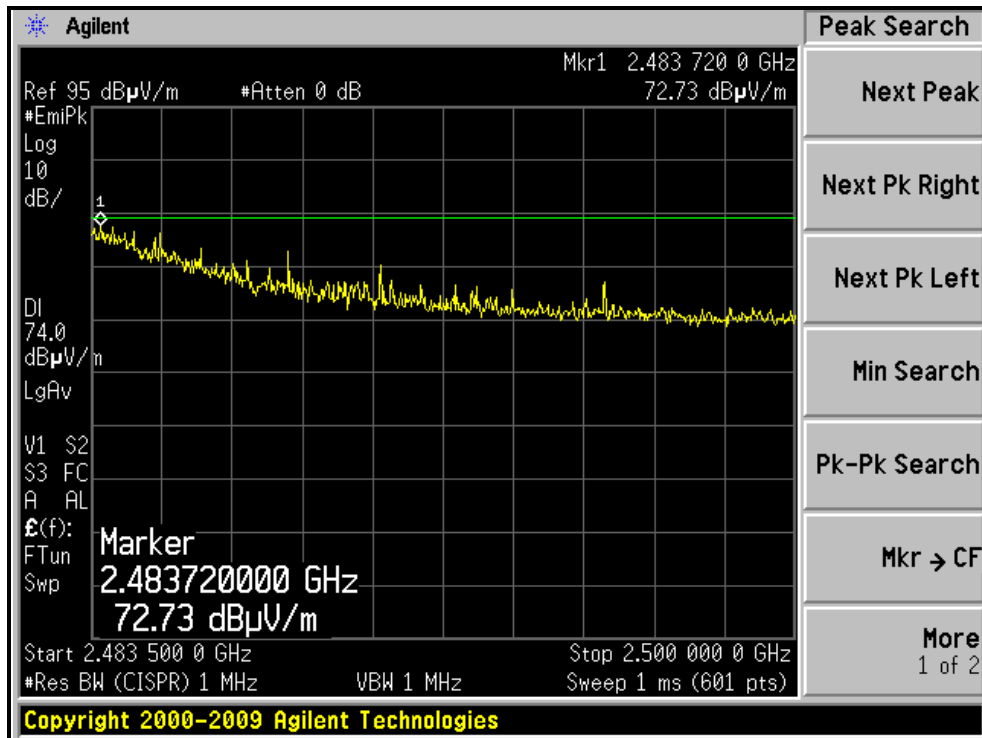



A D T

RESTRICTED BANDEDGE (802.11n (20MHz) MODE,CH13, HORIZONTAL)

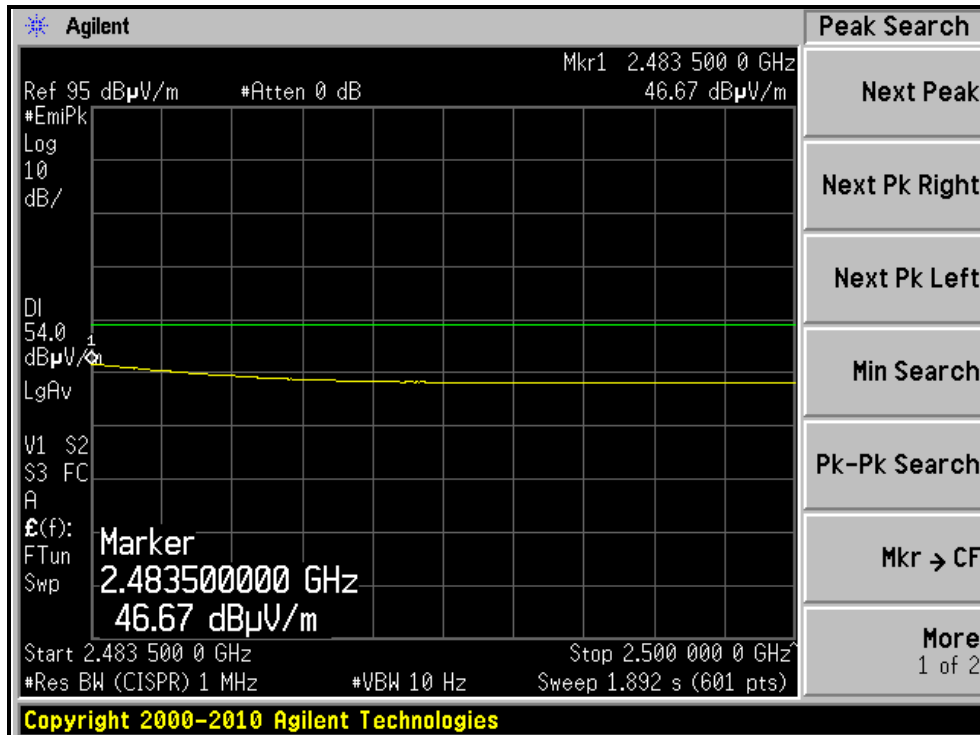
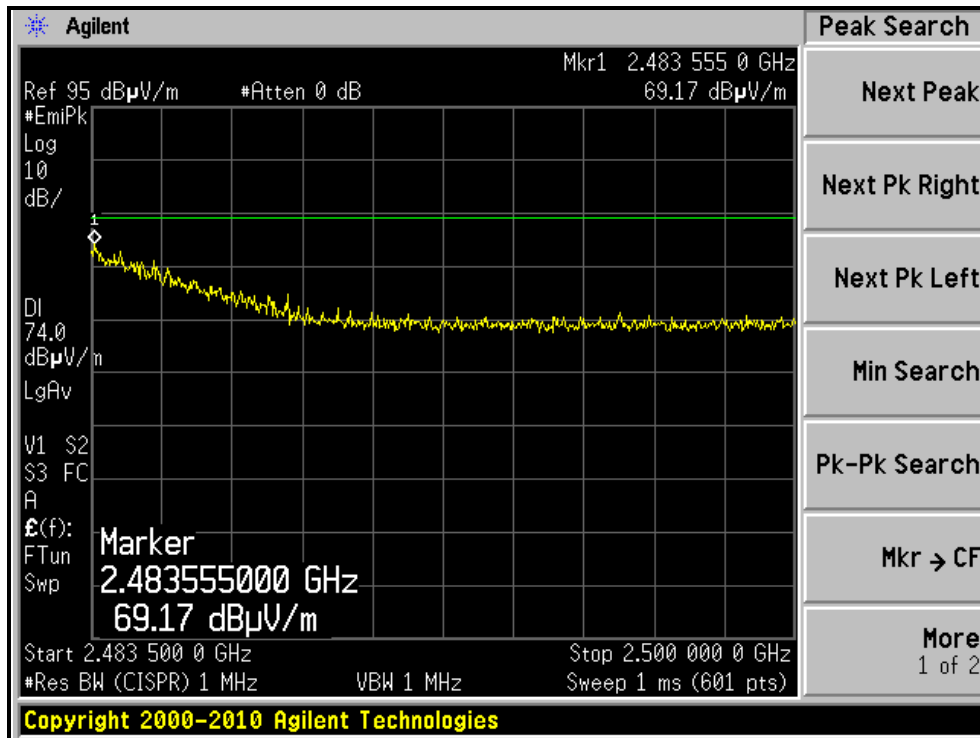

RESTRICTED BANDEDGE (802.11n (20MHz) MODE,CH13, VERTICAL)

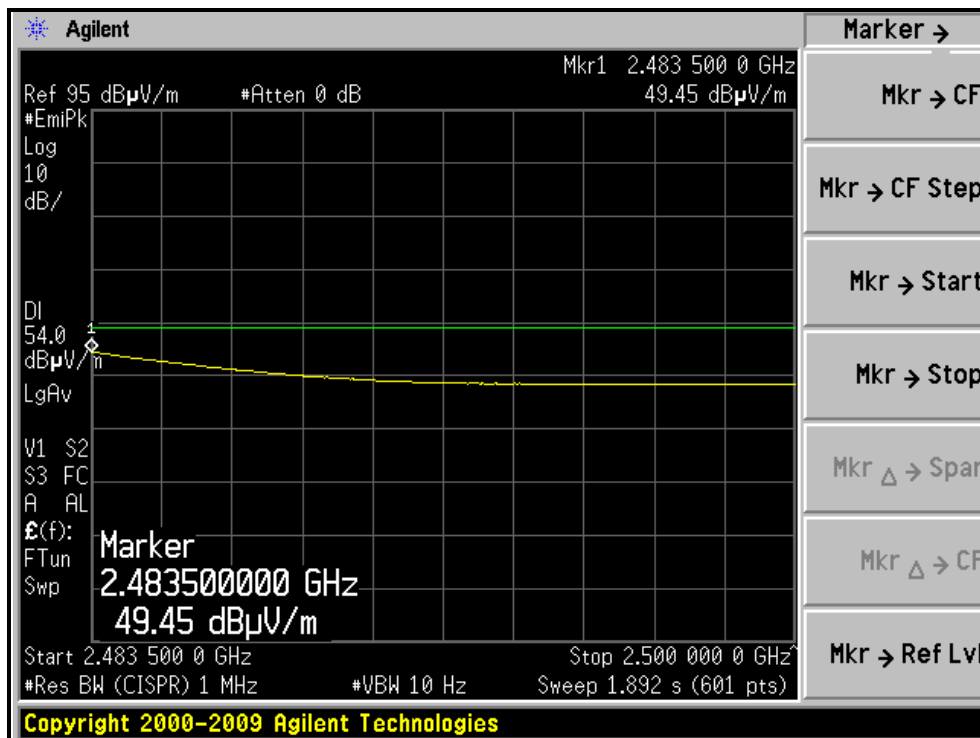
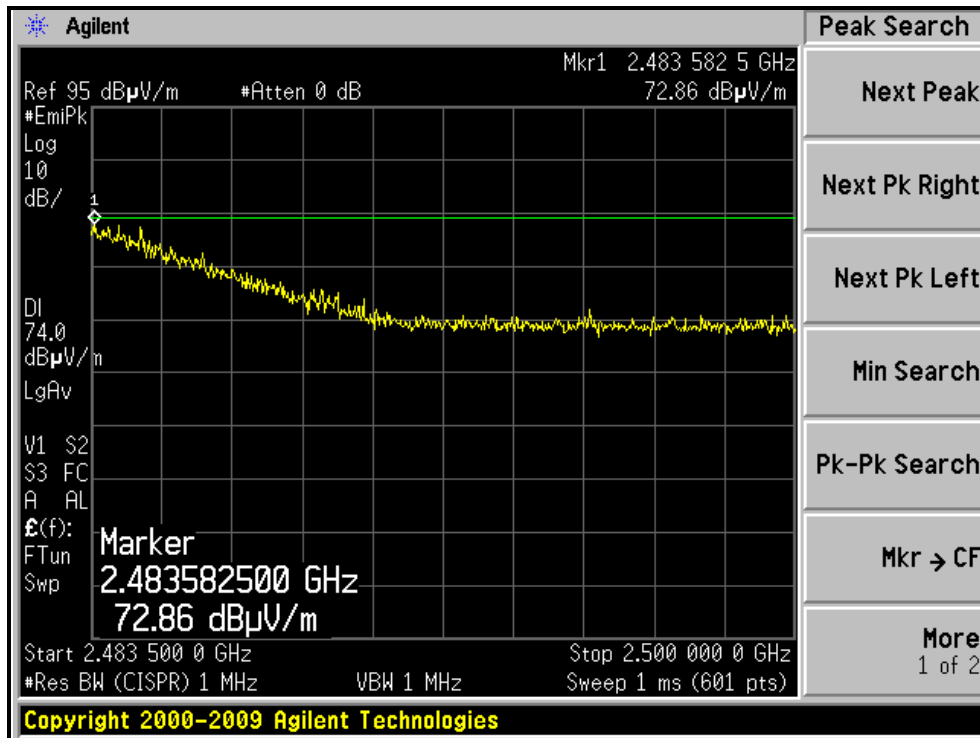

4.3 6dB BANDWIDTH MEASUREMENT

4.3.1 LIMITS OF 6dB BANDWIDTH MEASUREMENT

The minimum of 6dB Bandwidth Measurement is 0.5 MHz.

4.3.2 TEST INSTRUMENTS

Test date: Nov. 23, 2011

DESCRIPTION & MANUFACTURER	MODEL NO.	SERIAL NO.	CALIBRATED DATE	CALIBRATED UNTIL
R&S Spectrum Analyzer	FSP40	100036	Dec. 08, 2010	Dec. 07, 2011

NOTE: The calibration interval of the above test instruments is 12 months and the calibrations are traceable to NML/ROC and NIST/USA.

4.3.3 TEST PROCEDURE

The transmitter output was connected to the spectrum analyzer through an attenuator. The bandwidth of the fundamental frequency was measured by spectrum analyzer with 100kHz RBW and 300kHz VBW. The 6dB bandwidth is defined as the total spectrum the power of which is higher than peak power minus 6dB.

4.3.4 DEVIATION FROM TEST STANDARD

No deviation

4.3.5 TEST SETUP



4.3.6 EUT OPERATING CONDITIONS

The software provided by client to enable the EUT under transmission condition continuously at lowest, middle and highest channel frequencies individually.

4.3.7 TEST RESULTS

802.11b DSSS MODULATION:

CHANNEL	CHANNEL FREQUENCY (MHz)	6dB BANDWIDTH (MHz)	MINIMUM LIMIT (MHz)	PASS / FAIL
1	2412	10.03	0.5	PASS
6	2437	9.92	0.5	PASS
11	2462	9.19	0.5	PASS
12	2467	9.73	0.5	PASS
13	2472	9.24	0.5	PASS

CH1

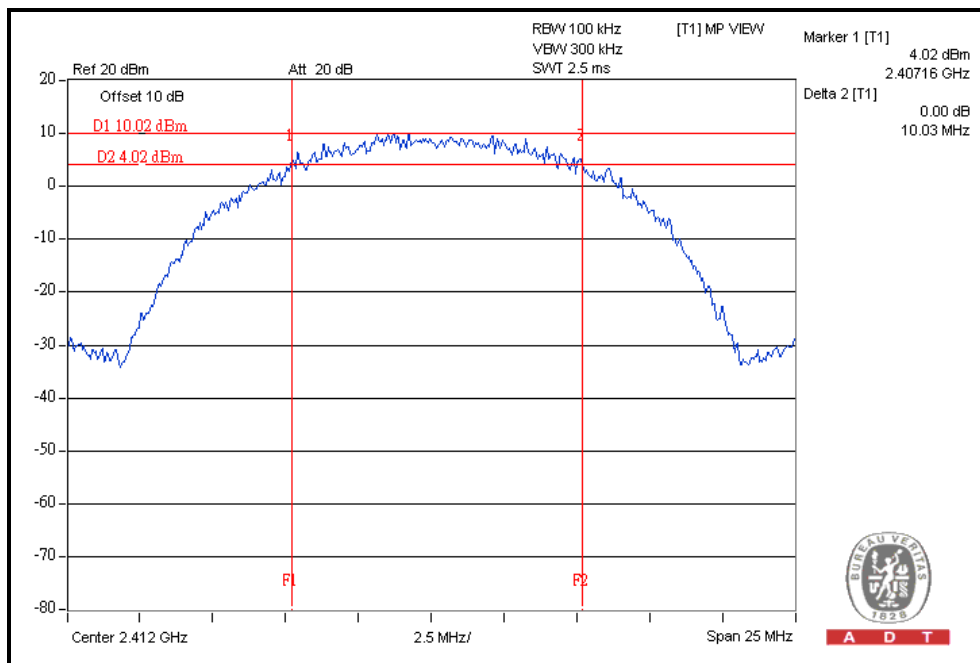



A D T

802.11g OFDM MODULATION:

CHANNEL	CHANNEL FREQUENCY (MHz)	6dB BANDWIDTH (MHz)	MINIMUM LIMIT (MHz)	PASS / FAIL
1	2412	13.87	0.5	PASS
6	2437	15.14	0.5	PASS
11	2462	12.95	0.5	PASS
12	2467	13.76	0.5	PASS
13	2472	15.14	0.5	PASS

CH6

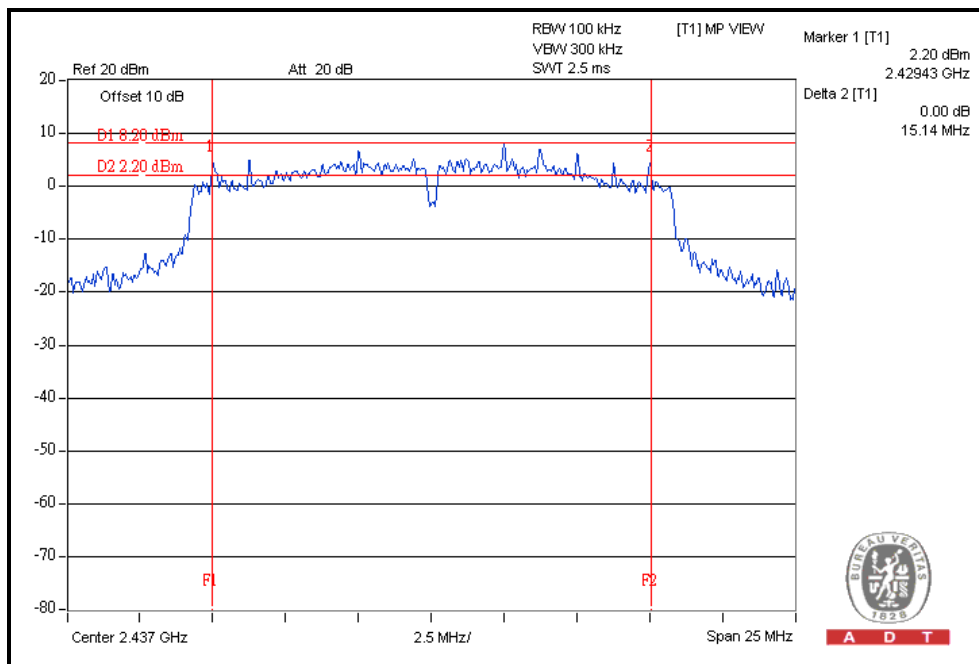



A D T

802.11n (20MHz) OFDM modulation:

CHANNEL	CHANNEL FREQUENCY (MHz)	6dB BANDWIDTH (MHz)	MINIMUM LIMIT (MHz)	PASS / FAIL
1	2412	15.10	0.5	PASS
6	2437	15.03	0.5	PASS
11	2462	13.98	0.5	PASS
12	2467	15.32	0.5	PASS
13	2472	15.23	0.5	PASS

CH12

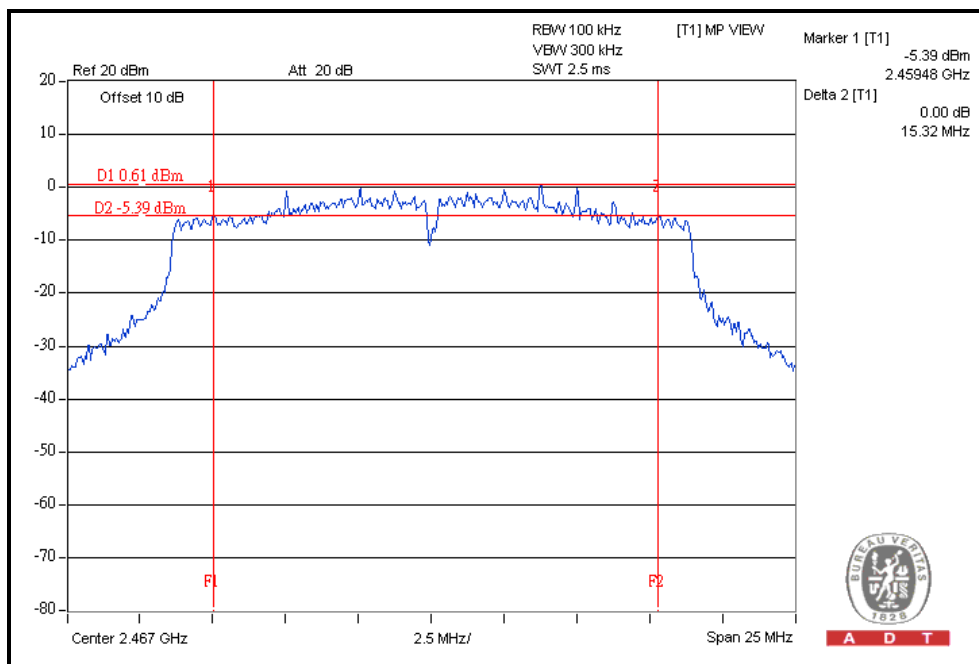

4.4 MAXIMUM PEAK OUTPUT POWER

4.4.1 LIMITS OF MAXIMUM PEAK OUTPUT POWER MEASUREMENT

The Maximum Peak Output Power Measurement is 30dBm.

4.4.2 INSTRUMENTS

Test date: Nov. 23, 2011

DESCRIPTION & MANUFACTURER	MODEL NO.	SERIAL NO.	CALIBRATED DATE	CALIBRATED UNTIL
Peak Power Meter	ML2495A	0824006	May 04, 2011	May 03, 2012
Power Sensor	MA2411B	0738172	May 03, 2011	May 02, 2012

NOTE: The calibration interval of the above test instruments is 12 months and the calibrations are traceable to NML/ROC and NIST/USA.

4.4.3 TEST PROCEDURES

1. The transmitter output was connected to the power meter through an attenuator; the bandwidth of the fundamental frequency was measured with the power meter.
2. Record the power level.

4.4.4 DEVIATION FROM TEST STANDARD

No deviation

4.4.5 TEST SETUP

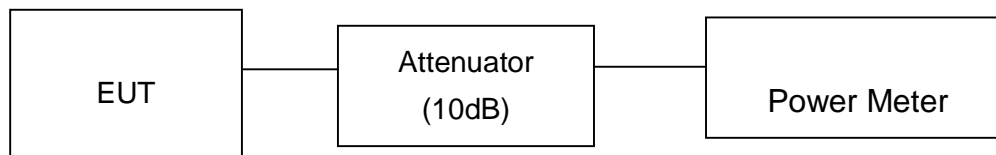

4.4.6 EUT OPERATING CONDITIONS

Same as Item 4.3.6



A D T

4.4.7 TEST RESULTS

802.11b DSSS MODULATION:

CHANNEL	CHANNEL FREQUENCY (MHz)	PEAK POWER OUTPUT (mW)	PEAK POWER OUTPUT (dBm)	PEAK POWER LIMIT (dBm)	PASS/FAIL
1	2412	177.8	22.5	30	PASS
2	2417	190.5	22.8	30	PASS
6	2437	204.2	23.1	30	PASS
10	2457	208.9	23.2	30	PASS
11	2462	208.9	23.2	30	PASS
12	2467	79.4	19.0	30	PASS
13	2472	33.1	15.2	30	PASS

Note: Output Power = Measurement PWR + Trace loss (0.75dB)

802.11g OFDM MODULATION:

CHANNEL	CHANNEL FREQUENCY (MHz)	PEAK POWER OUTPUT (mW)	PEAK POWER OUTPUT (dBm)	PEAK POWER LIMIT (dBm)	PASS/FAIL
1	2412	208.9	23.2	30	PASS
2	2417	218.8	23.4	30	PASS
3	2422	239.9	23.8	30	PASS
6	2437	245.5	23.9	30	PASS
9	2452	251.2	24.0	30	PASS
10	2457	257.0	24.1	30	PASS
11	2462	245.5	23.9	30	PASS
12	2467	195.0	22.9	30	PASS
13	2472	12.9	11.1	30	PASS

Note: Output Power = Measurement PWR + Trace loss (0.75dB)



A D T

802.11n (20MHz) OFDM MODULATION:

CHANNEL	CHANNEL FREQUENCY (MHz)	PEAK POWER OUTPUT (mW)	PEAK POWER OUTPUT (dBm)	PEAK POWER LIMIT (dBm)	PASS/FAIL
1	2412	204.2	23.1	30	PASS
2	2417	218.8	23.4	30	PASS
3	2422	239.9	23.8	30	PASS
6	2437	239.9	23.8	30	PASS
9	2452	251.2	24.0	30	PASS
10	2457	245.5	23.9	30	PASS
11	2462	234.4	23.7	30	PASS
12	2467	151.4	21.8	30	PASS
13	2472	12.3	10.9	30	PASS

Note: Output Power = Measurement PWR + Trace loss (0.75dB)

4.5 POWER SPECTRAL DENSITY MEASUREMENT

4.5.1 LIMITS OF POWER SPECTRAL DENSITY MEASUREMENT

The Maximum of Power Spectral Density Measurement is 8dBm.

4.5.2 TEST INSTRUMENTS

Test date: Nov. 23, 2011

DESCRIPTION & MANUFACTURER	MODEL NO.	SERIAL NO.	CALIBRATED DATE	CALIBRATED UNTIL
R&S Spectrum Analyzer	FSP40	100036	Dec. 08, 2010	Dec. 07, 2011

NOTE: The calibration interval of the above test instruments is 12 months and the calibrations are traceable to NML/ROC and NIST/USA.

4.5.3 TEST PROCEDURE

The transmitter output was connected to the spectrum analyzer through an attenuator, the bandwidth of the fundamental frequency was measured with the spectrum analyzer using 3kHz RBW and 30kHz VBW, set sweep time = span/3kHz. The power spectral density was measured and recorded. The sweep time is allowed to be longer than span/3kHz for a full response of the mixer in the spectrum analyzer.

4.5.4 DEVIATION FROM TEST STANDARD

No deviation

4.5.5 TEST SETUP

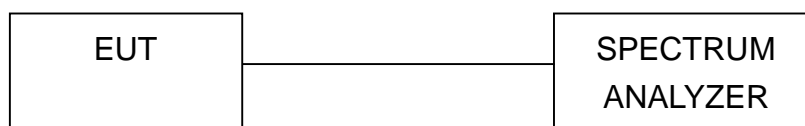

4.5.6 EUT OPERATING CONDITION

Same as Item 4.3.6



A D T

4.5.7 TEST RESULTS

802.11b DSSS MODULATION:

CHANNEL	FREQUENCY (MHz)	PSD (dBm/3kHz)	Limit (dBm/3kHz)	PASS / FAIL
1	2412	-3.3	8	PASS
6	2437	-3.0	8	PASS
11	2462	-4.6	8	PASS
12	2467	-6.9	8	PASS
13	2472	-11.9	8	PASS

Note: PSD = Measurement PSD + Trace loss (0.75dB)

CH6

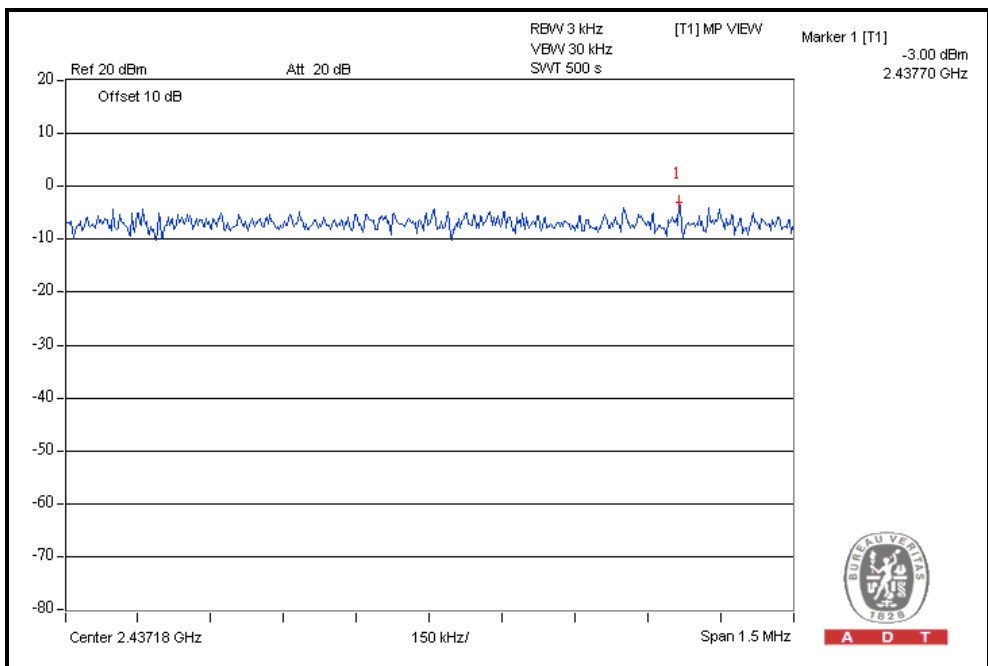



A D T

802.11g OFDM MODULATION:

CHANNEL	FREQUENCY (MHz)	PSD (dBm/3kHz)	Limit (dBm/3kHz)	PASS / FAIL
1	2412	-7.2	8	PASS
6	2437	-5.8	8	PASS
11	2462	-8.6	8	PASS
12	2467	-10.2	8	PASS
13	2472	-23.5	8	PASS

Note: PSD = Measurement PSD + Trace loss (0.75dB)

CH6

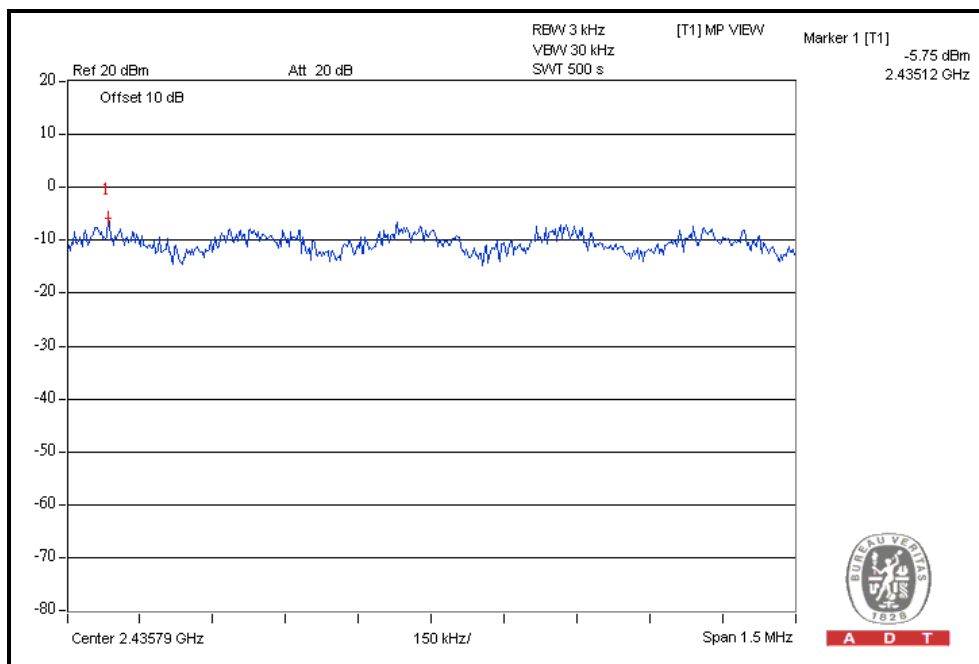



A D T

802.11n (20MHz) OFDM MODULATION:

CHANNEL	FREQUENCY (MHz)	PSD (dBm/3kHz)	Limit (dBm/3kHz)	PASS / FAIL
1	2412	-7.7	8	PASS
6	2437	-7.1	8	PASS
11	2462	-8.6	8	PASS
12	2467	-11.5	8	PASS
13	2472	-24.6	8	PASS

Note: PSD = Measurement PSD + Trace loss (0.75dB)

CH6

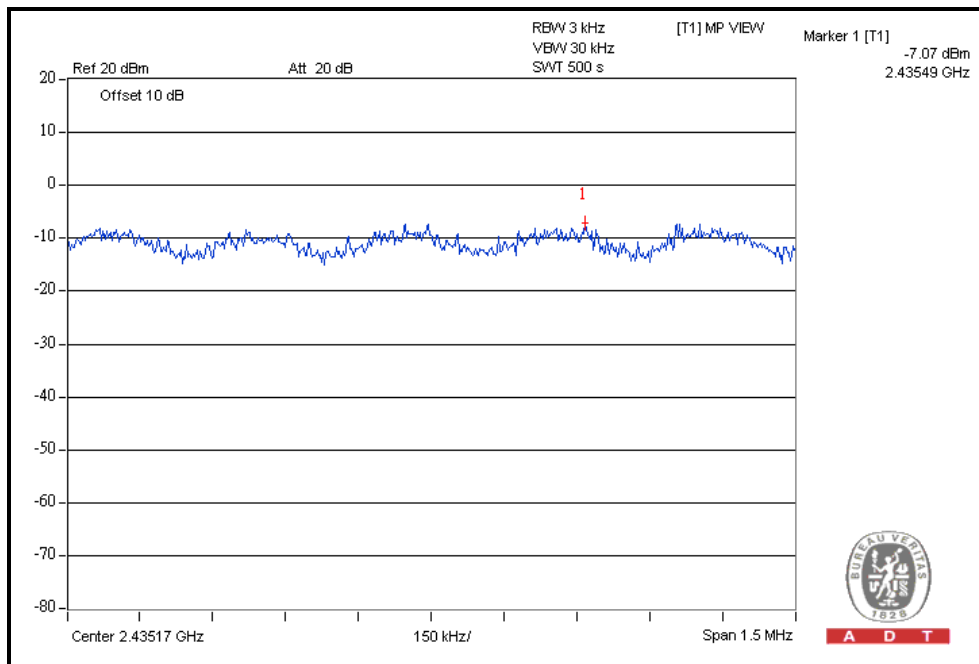

4.6 CONDUCTED OUT-BAND EMISSION MEASUREMENT

4.6.1 LIMITS OF CONDUCTED OUT-BAND EMISSION MEASUREMENT

Below -20dB of the highest emission level of operating band (in 100kHz Resolution Bandwidth).

4.6.2 TEST INSTRUMENTS

Test date: Nov. 23, 2011

DESCRIPTION & MANUFACTURER	MODEL NO.	SERIAL NO.	CALIBRATED DATE	CALIBRATED UNTIL
R&S Spectrum Analyzer	FSP40	100036	Dec. 08, 2010	Dec. 07, 2011

NOTE: The calibration interval of the above test instruments is 12 months and the calibrations are traceable to NML/ROC and NIST/USA.

4.6.3 TEST PROCEDURE

The transmitter output was connected to the spectrum analyzer via a low loss cable. Set RBW of spectrum analyzer to 100kHz and VBW of spectrum analyzer to 300kHz with suitable frequency span including 100MHz or 200MHz bandwidth from band edge. The band edges was measured and recorded.

The spectrum plots (RBW = 100kHz, VBW = 300kHz) are attached on the following pages.

4.6.4 DEVIATION FROM TEST STANDARD

No deviation

4.6.5 EUT OPERATING CONDITION

Same as Item 4.3.6

4.6.6 TEST RESULTS

The spectrum plots are attached on the following images. D1 line indicates the highest level, and D2 line indicates the 20dB offset below D1. It shows compliance with the requirement in part 15.247(d).



A D T

802.11b DSSS MODULATION:

CH1

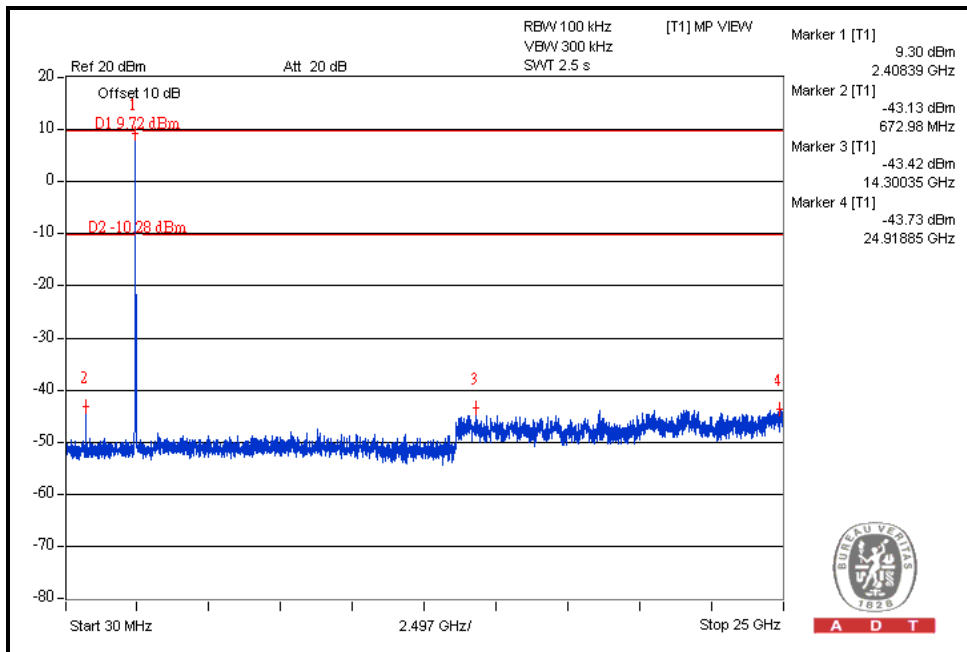
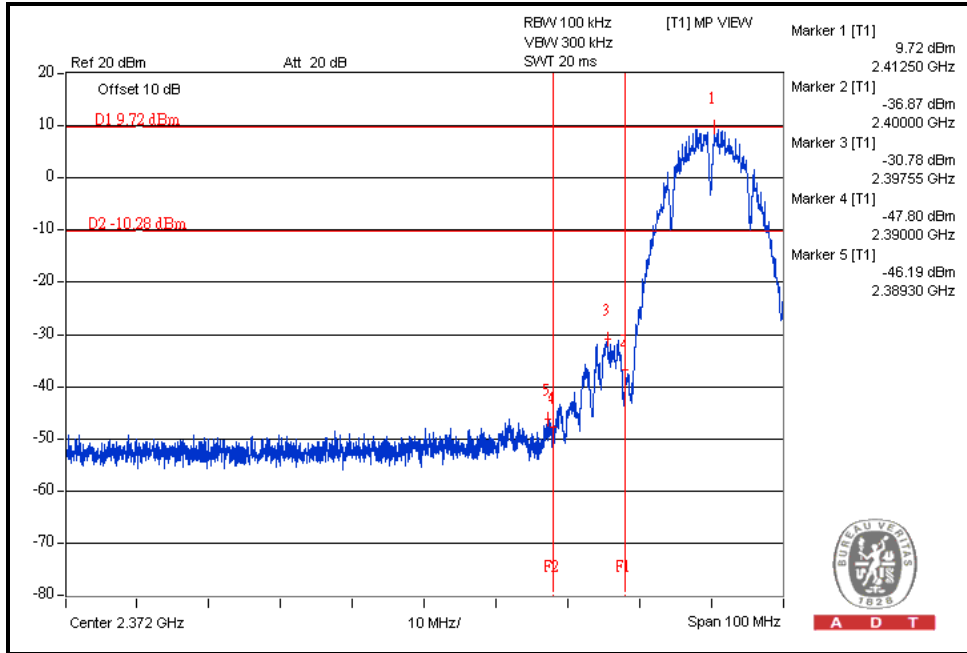



A D T

CH11

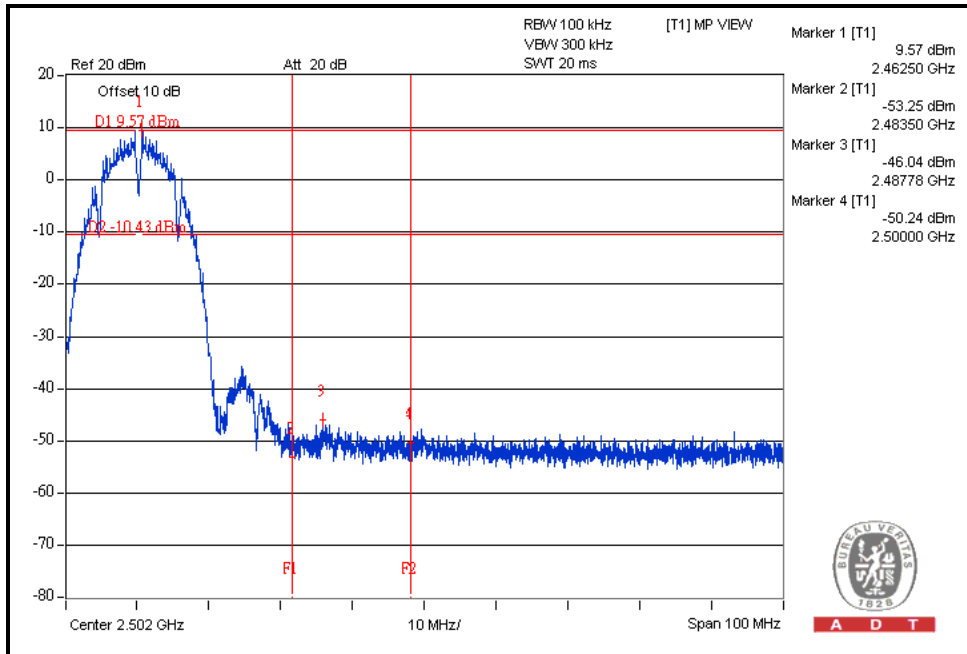

A D T

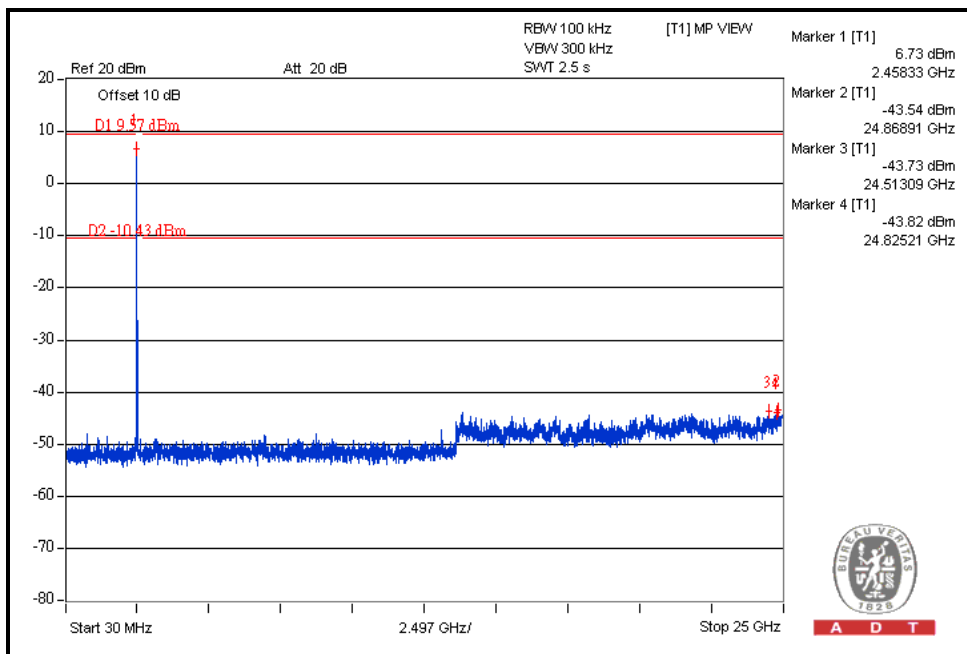

A D T



A D T

CH12

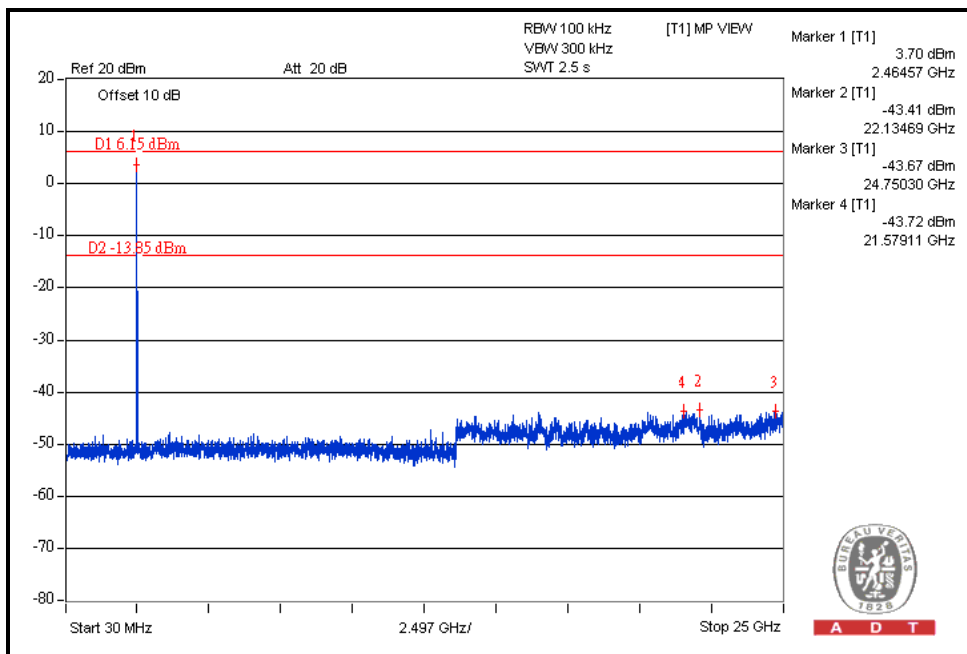
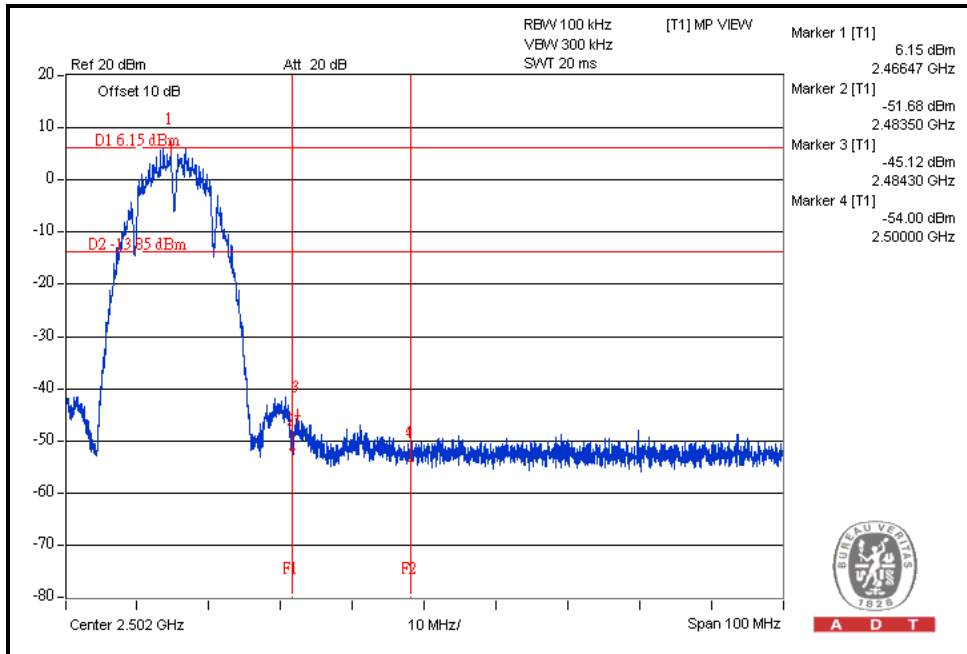



A D T

CH13

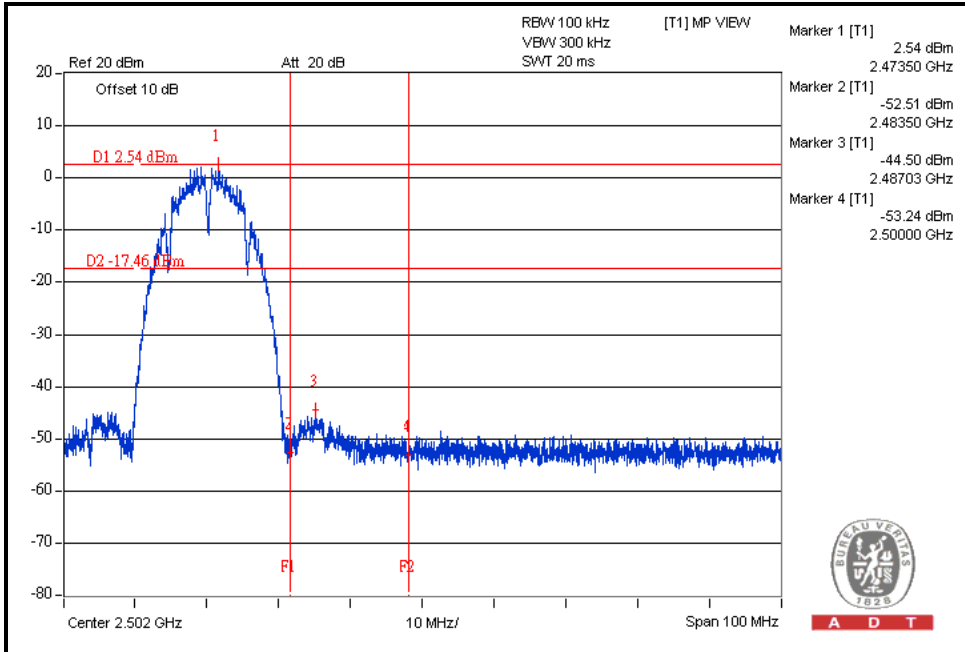

A D T

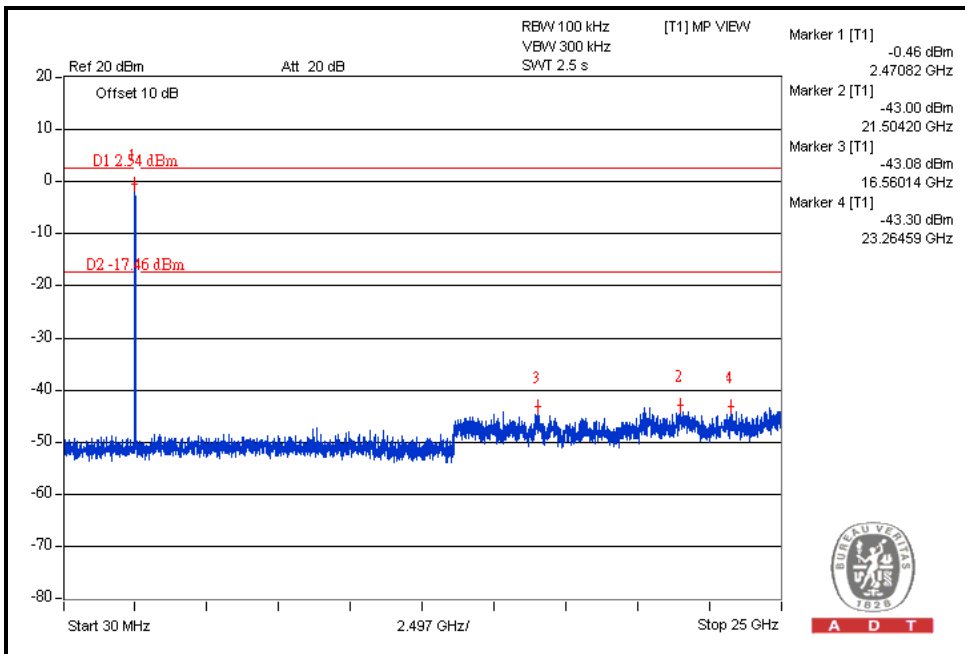

A D T



A D T

802.11g OFDM MODULATION:

CH1

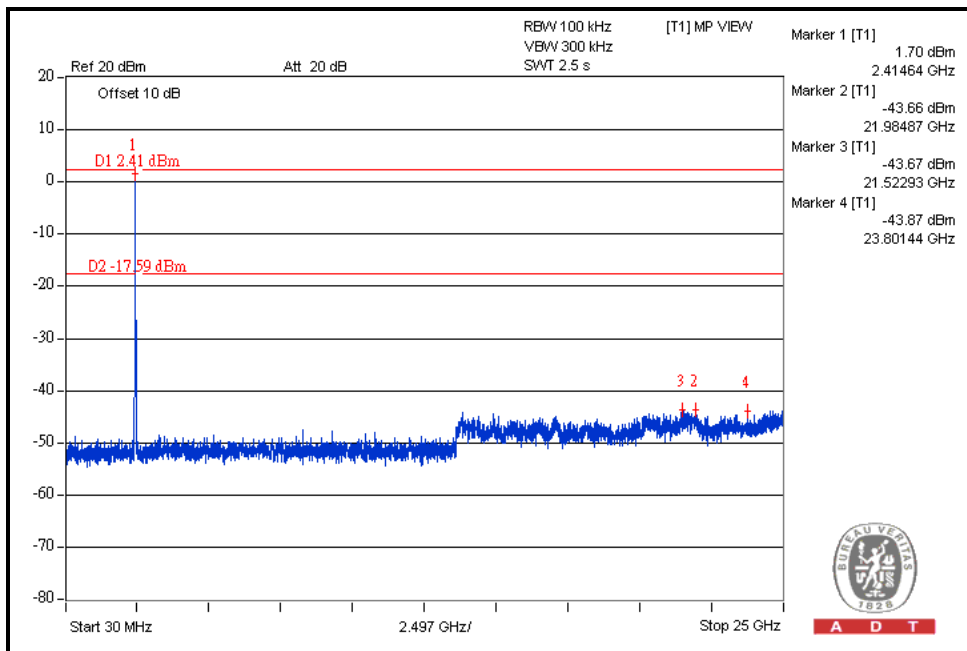
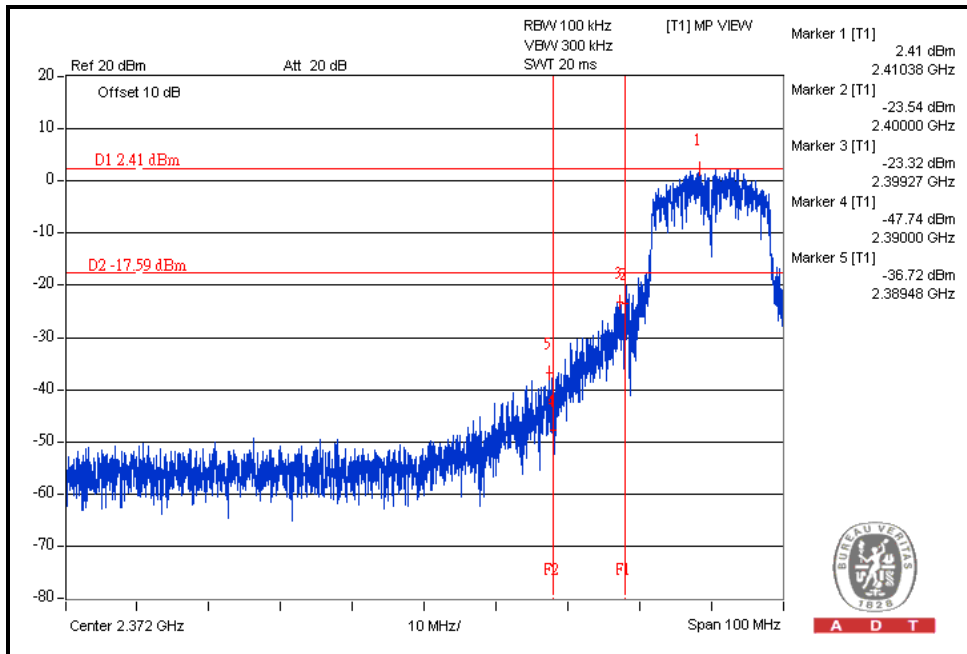



A D T

CH11

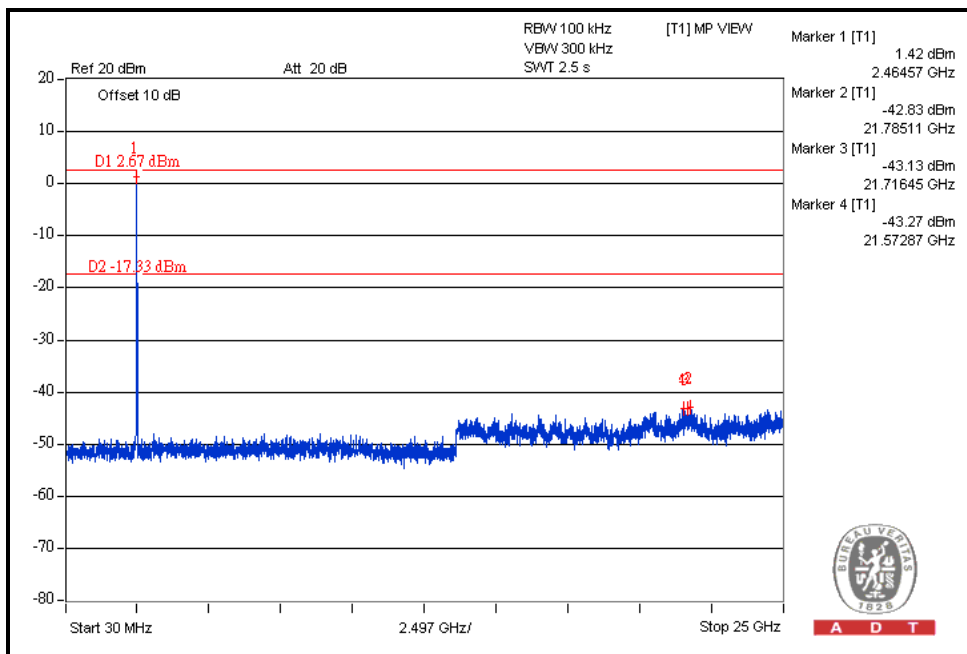
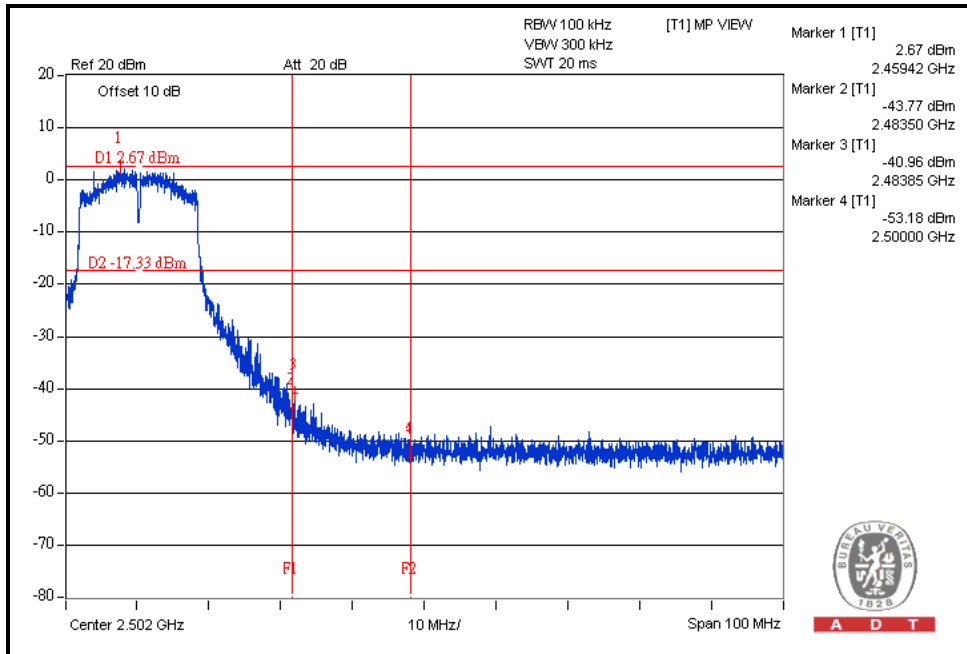

CH12

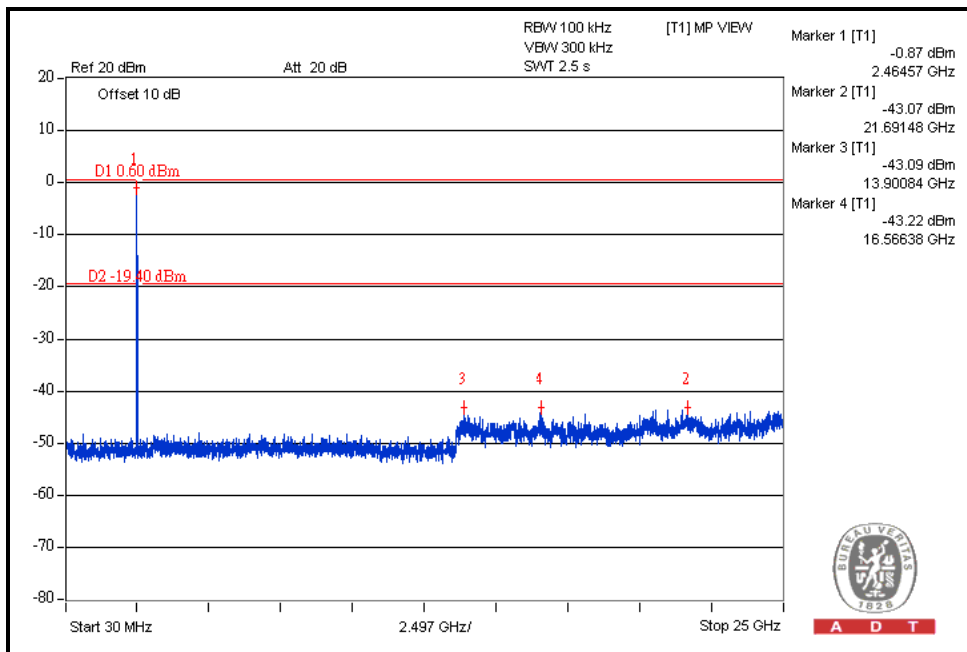
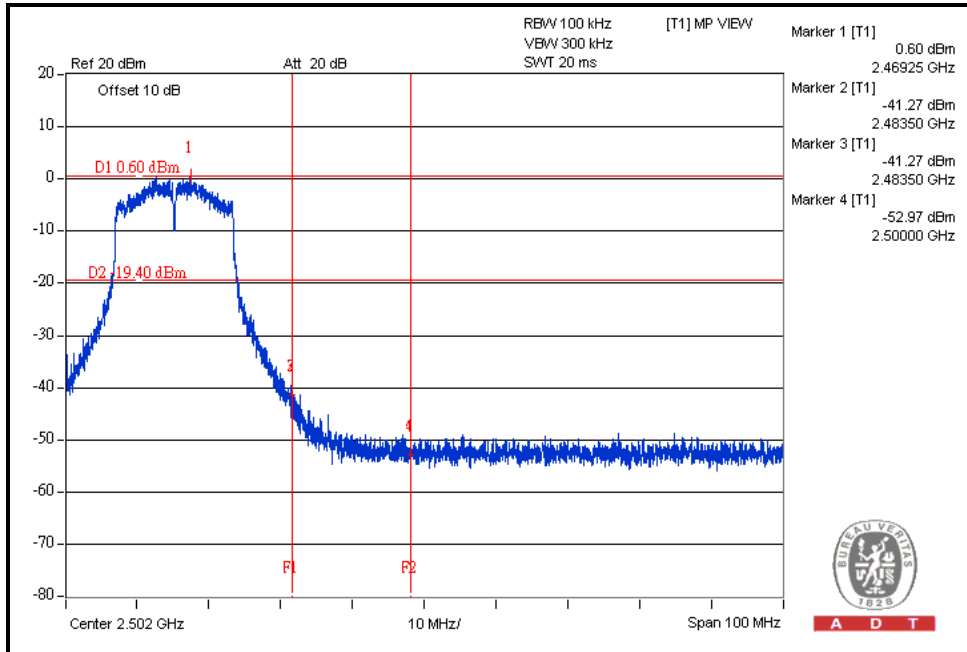



A D T

CH13

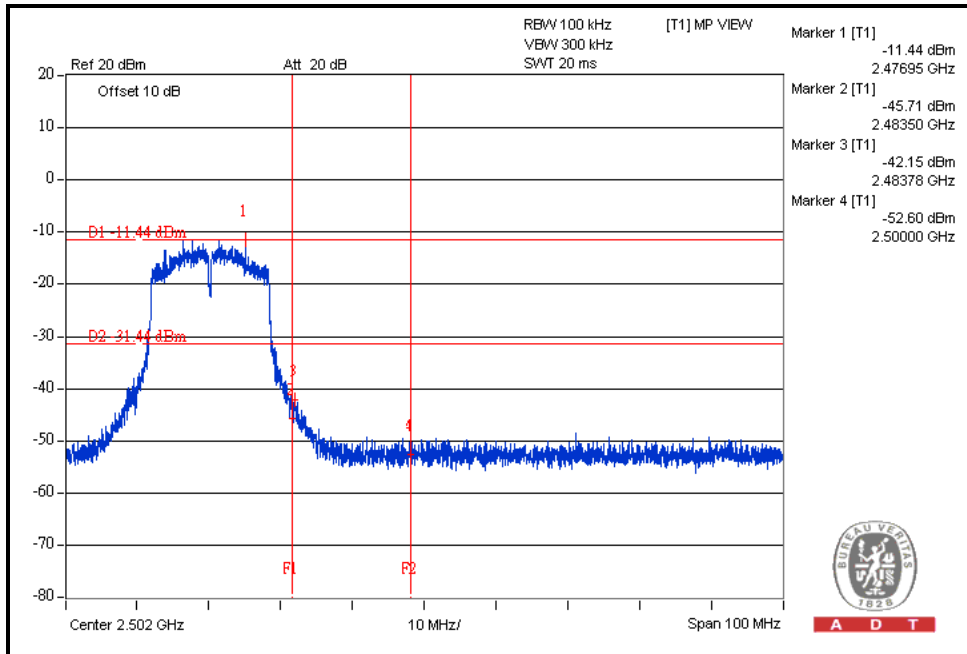

A D T

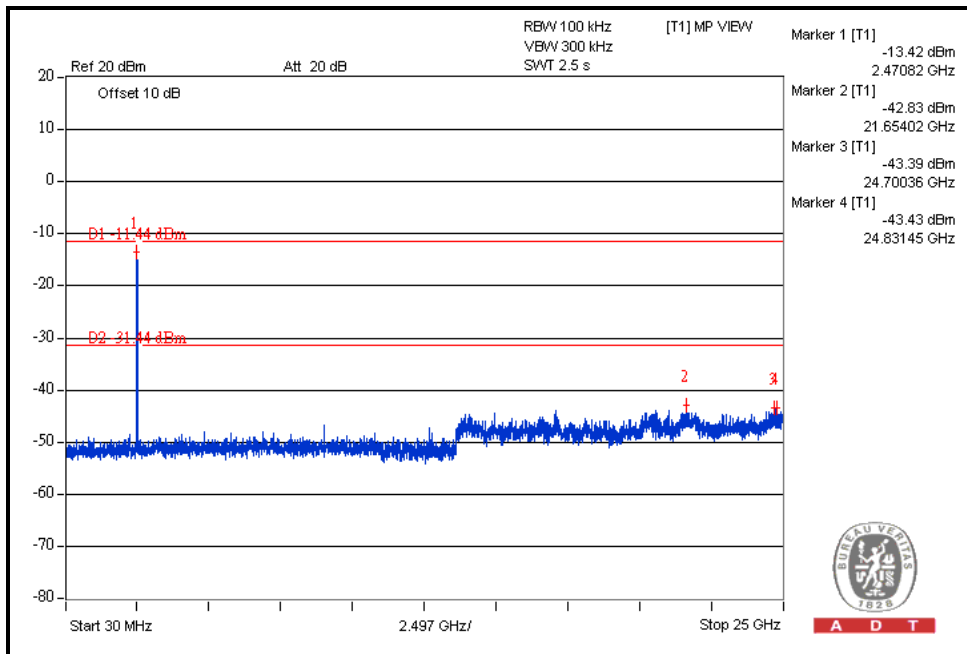

A D T



A D T

802.11n (20MHz) OFDM MODULATION:

CH1

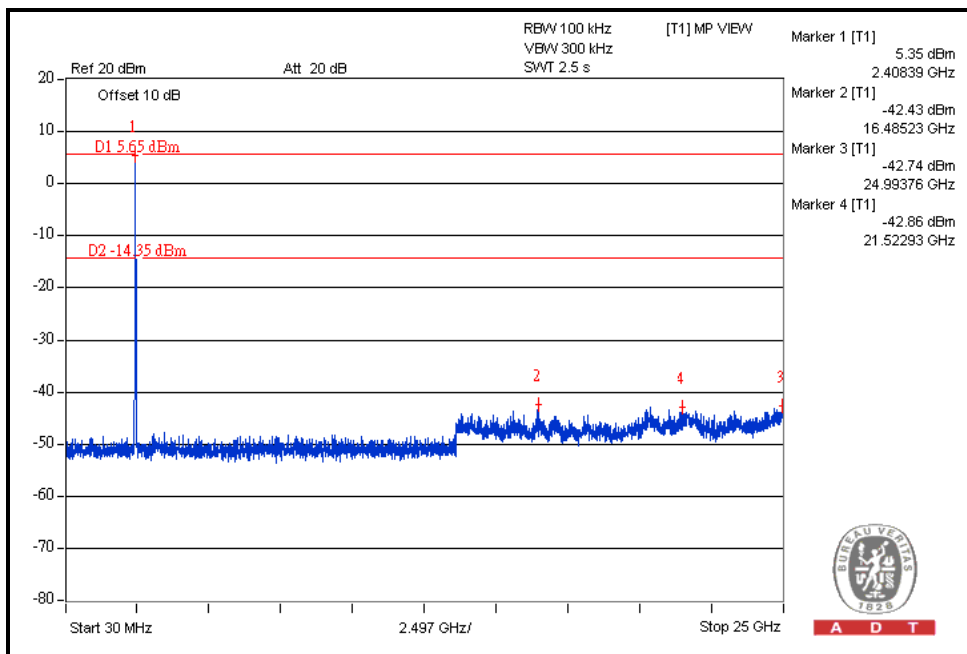
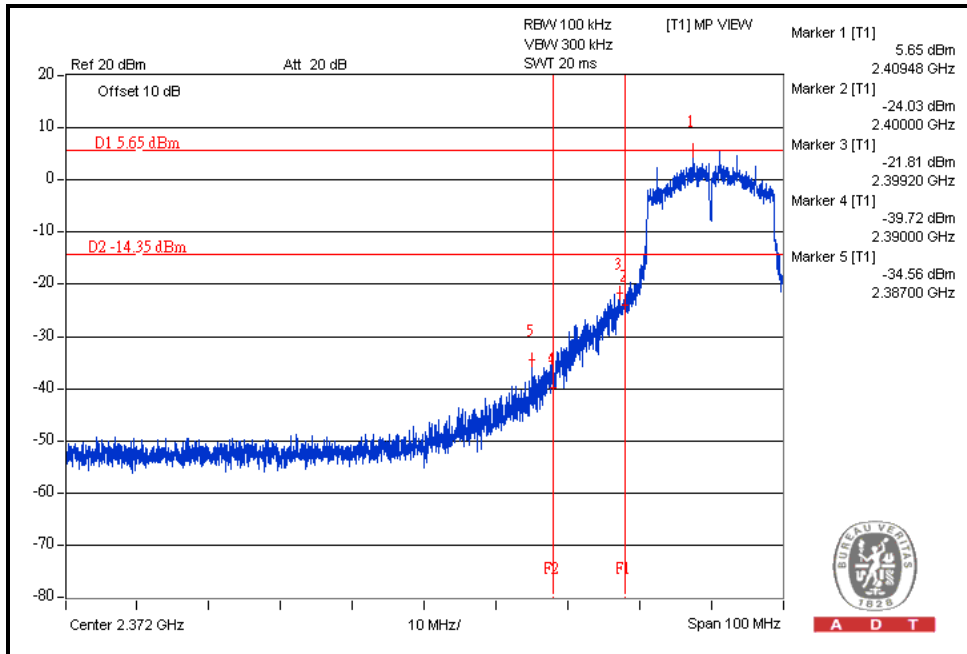



A D T

CH11

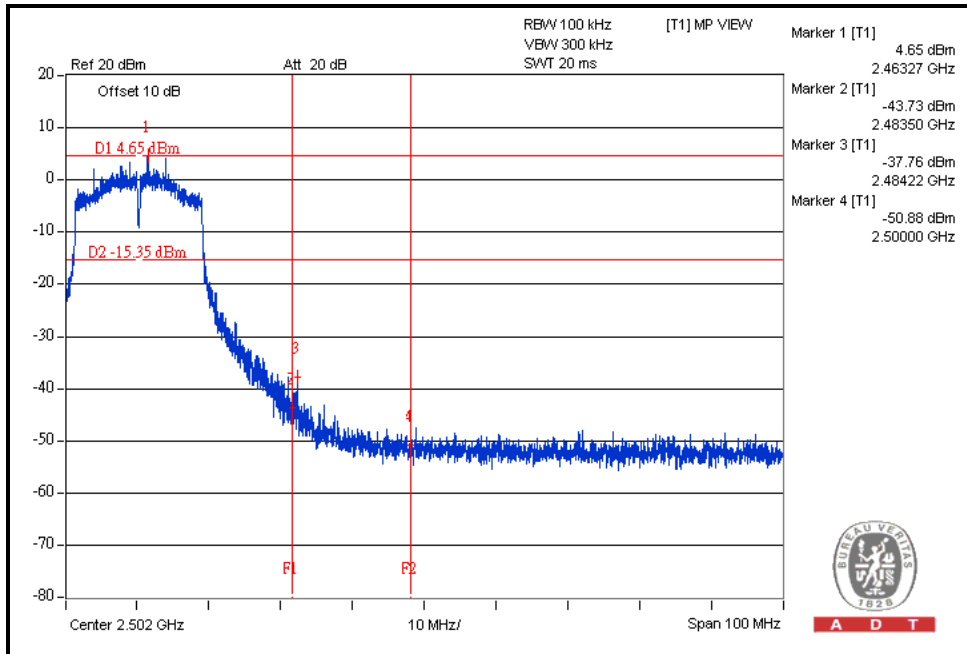

A D T

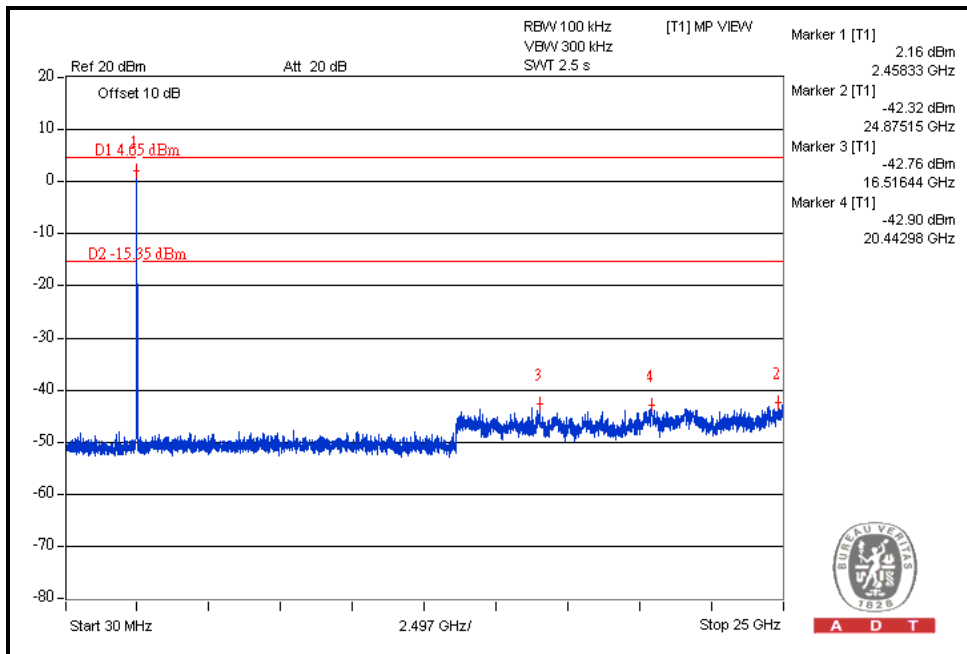

A D T



A D T

CH12

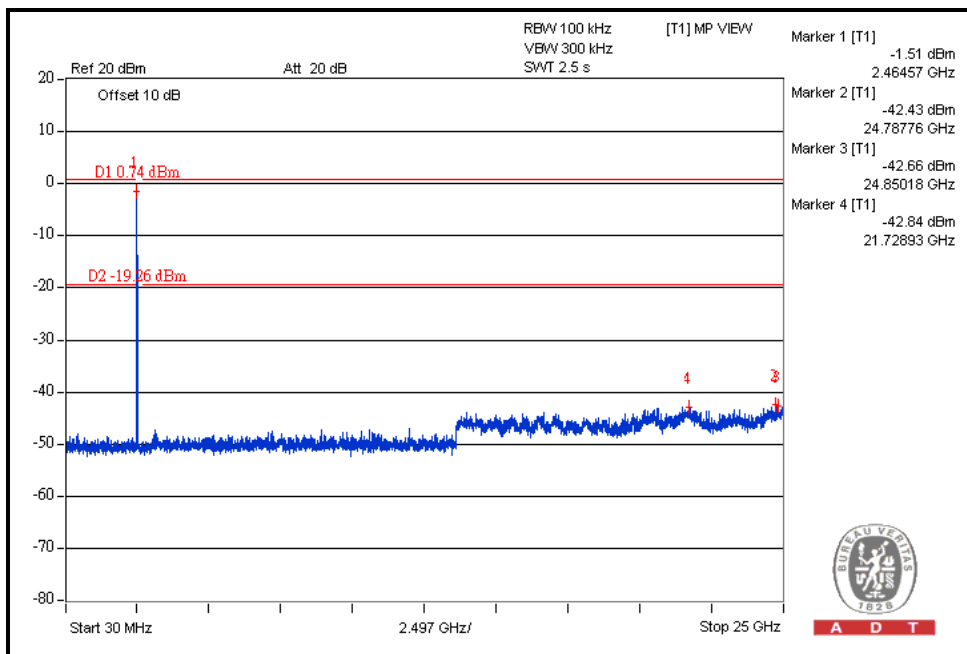
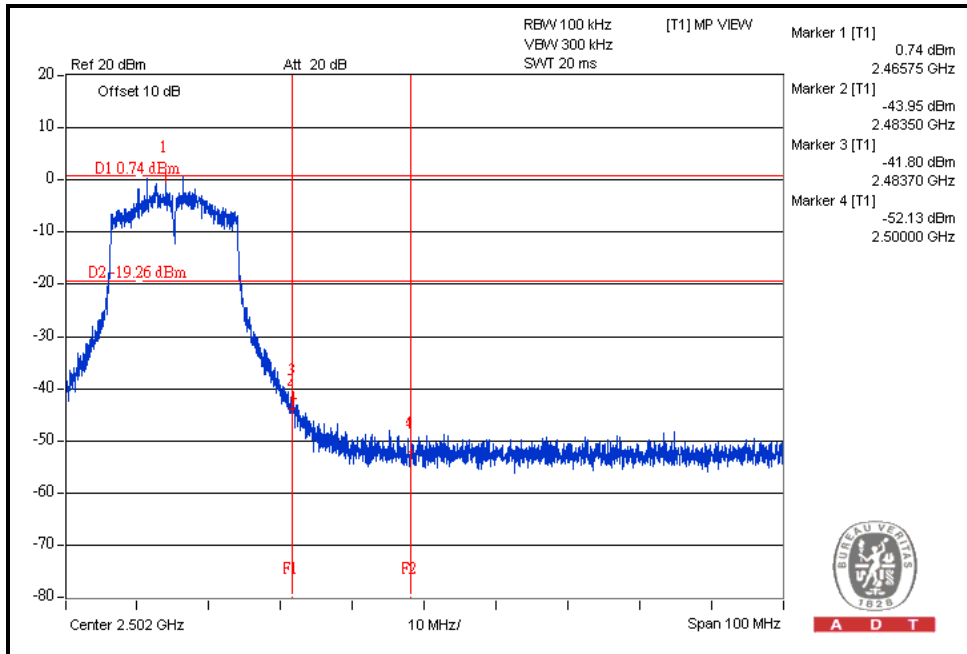



A D T

CH13

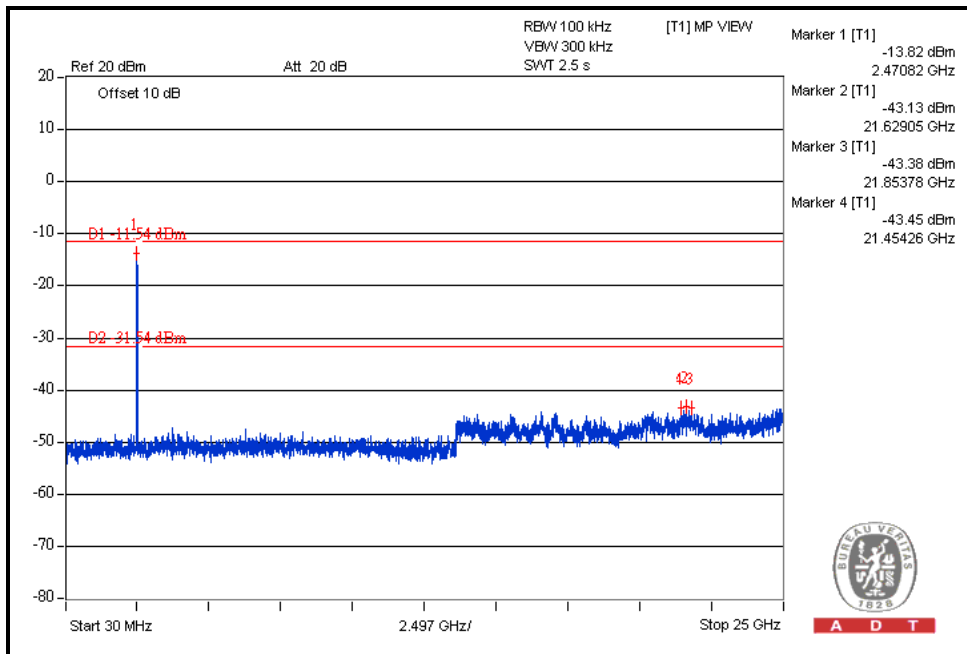
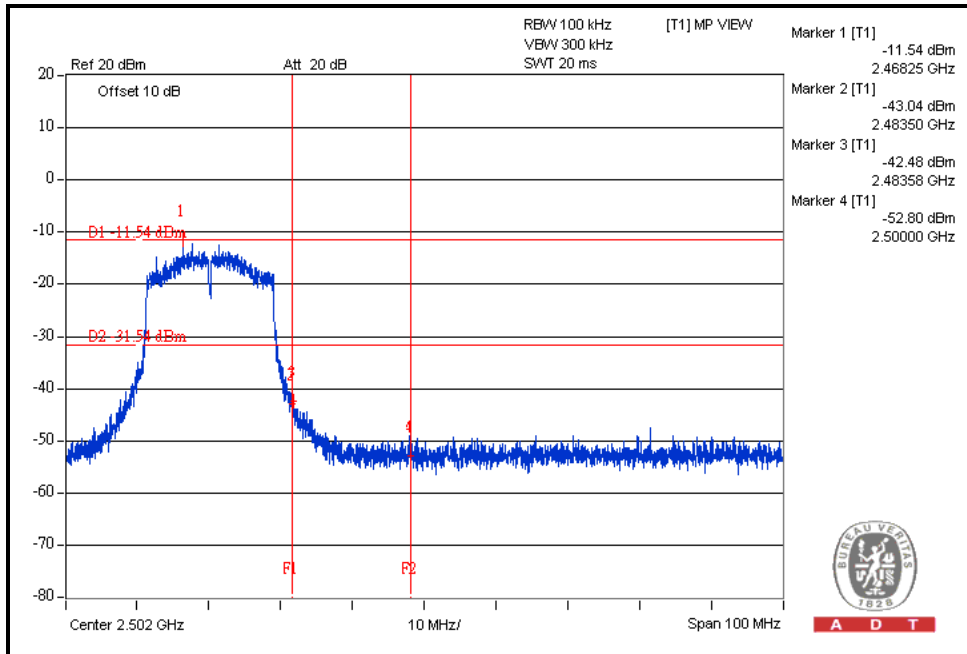



A D T

5. TEST TYPES AND RESULTS (802.11a, 5725~5850MHz Band)

5.1 CONDUCTED EMISSION MEASUREMENT

5.1.1 LIMITS OF CONDUCTED EMISSION MEASUREMENT

FREQUENCY OF EMISSION (MHz)	CONDUCTED LIMIT (dB μ V)	
	Quasi-peak	Average
0.15-0.5	66 to 56	56 to 46
0.5-5	56	46
5-30	60	50

- NOTE:**
1. The lower limit shall apply at the transition frequencies.
 2. The limit decreases in line with the logarithm of the frequency in the range of 0.15 to 0.50 MHz.

5.1.2 TEST INSTRUMENTS

Test date: Nov. 14, 2011

DESCRIPTION & MANUFACTURER	MODEL NO.	SERIAL NO.	CALIBRATED DATE	CALIBRATED UNTIL
Test Receiver	ESCS 30	100375	Mar. 09, 2011	Mar. 08, 2012
Line-Impedance Stabilization Network (for EUT)	NSLK8127	8127-522	Sep. 07, 2011	Sep. 06, 2012
Line-Impedance Stabilization Network (for Peripheral)	ESH3-Z5	848773/004	Nov. 01, 2011	Oct. 31, 2012
RF Cable (JYEBAO)	5DFB	COCCAB-002	Aug. 29, 2011	Aug. 28, 2012
50 ohms Terminator	50	3	Nov. 02, 2011	Nov. 01, 2012
Software	BV ADT_Cond_V7.3.7	NA	NA	NA

Note:

1. The calibration interval of the above test instruments is 12 months and the calibrations are traceable to NML/ROC and NIST/USA.
2. The test was performed in Shielded Room No. C.
3. The VCCI Con C Registration No. is C-3611.



A D T

5.1.3 TEST PROCEDURES

- a. The EUT was placed 0.4 meters from the conducting wall of the shielded room with EUT being connected to the power mains through a line impedance stabilization network (LISN). Other support units were connected to the power mains through another LISN. The two LISNs provide 50 ohm/50uH of coupling impedance for the measuring instrument.
- b. Both lines of the power mains connected to the EUT were checked for maximum conducted interference.
- c. The frequency range from 150kHz to 30MHz was searched. Emission levels under (Limit – 20dB) were not recorded.

5.1.4 DEVIATION FROM TEST STANDARD

No deviation

5.1.5 TEST SETUP

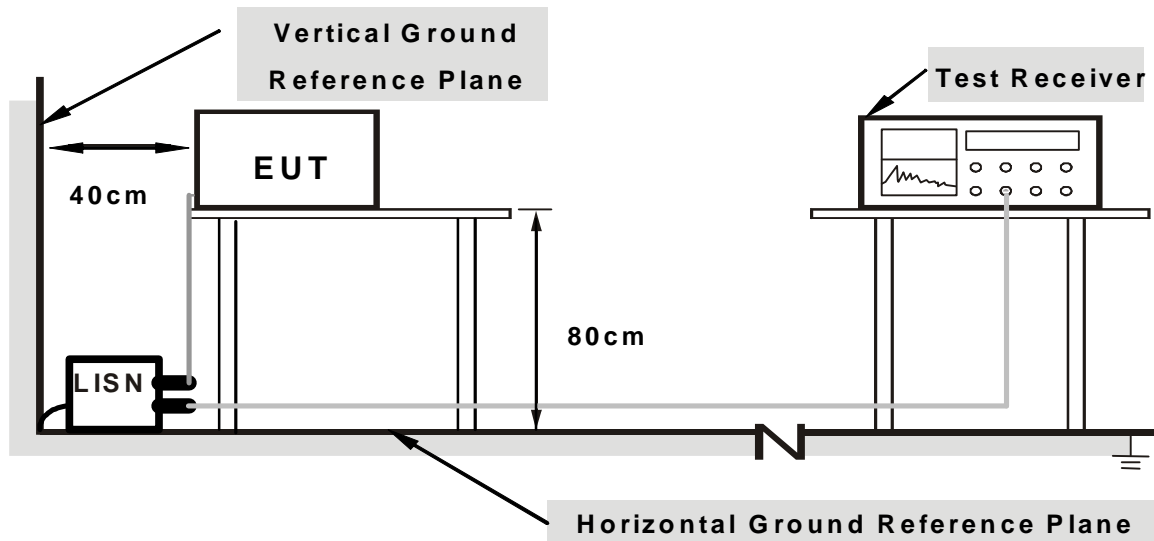

Note: 1.Support units were connected to second LISN.

2.Both of LISNs (AMN) are 80 cm from EUT and at least 80 from other units and other metal planes

For the actual test configuration, please refer to the related item – Photographs of the Test Configuration.

5.1.6 EUT OPERATING CONDITIONS

Same as the 4.1.6

5.1.7 TEST RESULTS

PHASE	Line (L)	6dB BANDWIDTH	9 kHz
--------------	----------	----------------------	-------

No	Freq. [MHz]	Corr. Factor (dB)	Reading Value [dB (uV)]		Emission Level [dB (uV)]		Limit [dB (uV)]		Margin (dB)	
			Q.P.	AV.	Q.P.	AV.	Q.P.	AV.	Q.P.	AV.
			1	0.185	0.10	11.35	2.62	11.45	2.72	64.25
2	0.330	0.11	8.32	7.37	8.43	7.48	59.46	49.46	-51.03	-41.98
3	0.388	0.11	7.92	3.17	8.03	3.28	58.10	48.10	-50.07	-44.82
4	5.578	0.38	21.26	14.64	21.64	15.02	60.00	50.00	-38.36	-34.98
5	9.215	0.52	28.06	23.64	28.58	24.16	60.00	50.00	-31.42	-25.84
6	11.949	0.59	26.12	22.07	26.71	22.66	60.00	50.00	-33.29	-27.34
7	15.363	0.67	25.68	22.23	26.35	22.90	60.00	50.00	-33.65	-27.10

- REMARKS:**
1. Q.P. and AV. are abbreviations of quasi-peak and average individually.
 2. The emission levels of other frequencies were very low against the limit.
 3. Margin value = Emission level - Limit value
 4. Correction factor = Insertion loss + Cable loss
 5. Emission Level = Correction Factor + Reading Value.

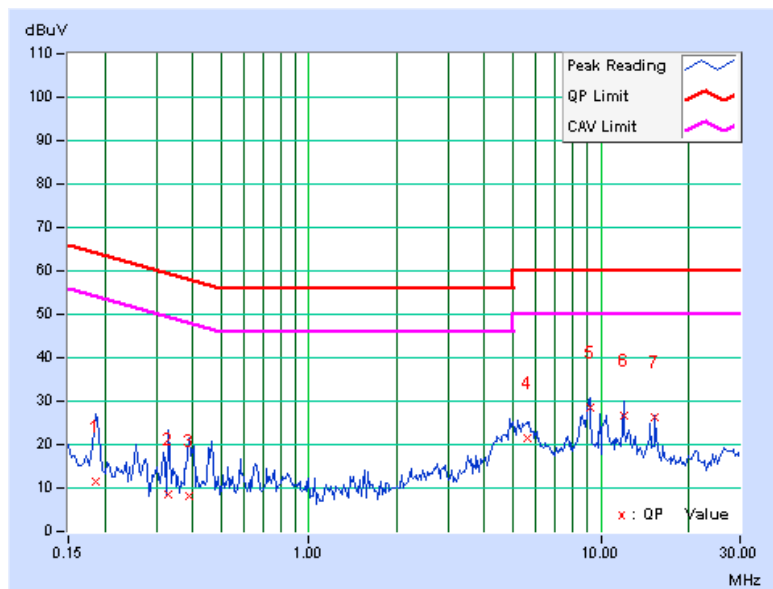

PHASE	Neutral (N)	6dB BANDWIDTH	9 kHz
--------------	-------------	----------------------	-------

No	Freq. [MHz]	Corr. Factor (dB)	Reading Value		Emission Level		Limit		Margin	
			[dB (uV)]		[dB (uV)]		[dB (uV)]		(dB)	
			Q.P.	AV.	Q.P.	AV.	Q.P.	AV.	Q.P.	AV.
1	0.162	0.08	10.41	5.81	10.49	5.89	65.38	55.38	-54.89	-49.49
2	0.209	0.09	11.13	4.21	11.22	4.30	63.26	53.26	-52.04	-48.96
3	0.283	0.10	8.27	7.54	8.37	7.64	60.73	50.73	-52.36	-43.09
4	0.420	0.11	15.76	7.64	15.87	7.75	57.46	47.46	-41.59	-39.71
5	5.473	0.28	21.37	15.26	21.65	15.54	60.00	50.00	-38.35	-34.46
6	8.688	0.37	21.32	14.74	21.69	15.11	60.00	50.00	-38.31	-34.89
7	10.402	0.42	23.77	19.59	24.19	20.01	60.00	50.00	-35.81	-29.99
8	11.949	0.46	26.57	22.35	27.03	22.81	60.00	50.00	-32.97	-27.19

- REMARKS:**
1. Q.P. and AV. are abbreviations of quasi-peak and average individually.
 2. The emission levels of other frequencies were very low against the limit.
 3. Margin value = Emission level - Limit value
 4. Correction factor = Insertion loss + Cable loss
 5. Emission Level = Correction Factor + Reading Value.

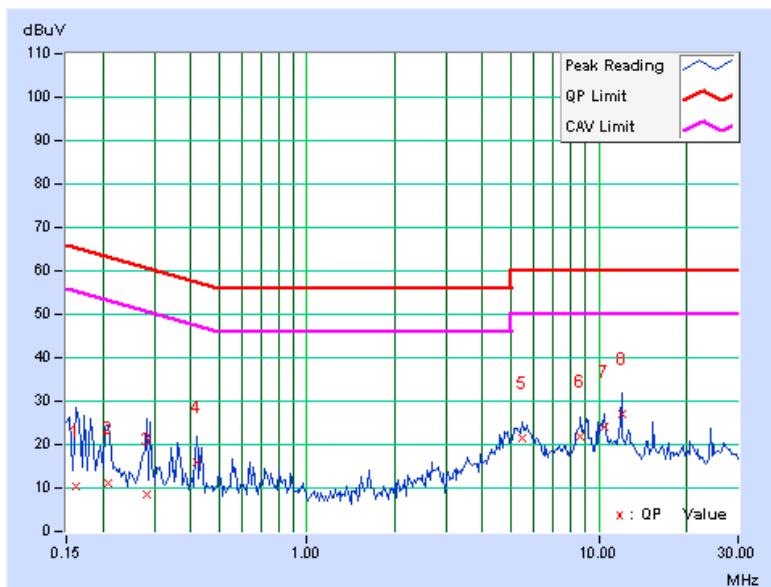



A D T

5.2 RADIATED EMISSION MEASUREMENT

5.2.1 LIMITS OF RADIATED EMISSION MEASUREMENT

Emissions radiated outside of the specified bands, shall be according to the general radiated limits in 15.209 as following:

Frequencies (MHz)	Field strength (microvolts/meter)	Measurement distance (meters)
0.009-0.490	2400/F(kHz)	300
0.490-1.705	24000/F(kHz)	30
1.705-30.0	30	30
30-88	100	3
88-216	150	3
216-960	200	3
Above 960	500	3

NOTE:

1. The lower limit shall apply at the transition frequencies.
2. Emission level (dBuV/m) = 20 log Emission level (uV/m).
3. As shown in 15.35(b), for frequencies above 1000MHz, the field strength limits are based on average detector, however, the peak field strength of any emission shall not exceed the maximum permitted average limits, specified above by more than 20dB under any condition of modulation.
4. Section 15.205 restricted bands of operation shall compliance with the limits in Section 15.209.



A D T

5.2.2 TEST INSTRUMENTS

For below 1GHz: Test date: Nov. 26, 2011

DESCRIPTION & MANUFACTURER	MODEL NO.	SERIAL NO.	CALIBRATED DATE	CALIBRATED UNTIL
Agilent Spectrum Analyzer	E4446A	MY48250253	Aug. 29, 2011	Aug. 28, 2012
Agilent Pre-Selector	N9039A	MY46520310	Aug. 29, 2011	Aug. 28, 2012
Agilent Signal Generator	N5181A	MY49060347	July 25, 2011	July 24, 2012
Mini-Circuits Pre-Amplifier	ZFL-1000VH2B	AMP-ZFL-04	Nov. 15, 2011	Nov. 14, 2012
Agilent Pre-Amplifier	8449B	3008A02465	Feb. 28, 2011	Feb. 27, 2012
SPACEK LABS	SLKKa-48-6	9K16	Nov. 15, 2011	Nov. 14, 2012
SCHWARZBECK Trilog Broadband Antenna	VULB 9168	9168-361	Apr. 14, 2011	Apr. 13, 2012
AISI Horn_Antenna	AIH.8018	0000220091110	Nov. 22, 2011	Nov. 21, 2012
SCHWARZBECK Horn_Antenna	BBHA 9170	9170-424	Oct. 07, 2011	Oct. 06, 2012
RF CABLE	NA	RF104-205 RF104-207 RF104-202	Dec. 28, 2010	Dec. 27, 2011
RF Cable	NA	CHHCAB_001	Oct. 08, 2011	Oct. 07, 2012
Software	ADT_Radiated_V8.7.05	NA	NA	NA
CT Antenna Tower & Turn Table	NA	NA	NA	NA

- Note: 1. The calibration interval of the above test instruments is 12 months and the calibrations are traceable to NML/ROC and NIST/USA.
2. The horn antenna, preamplifier (model: 8449B) are used only for the measurement of emission frequency above 1GHz if tested.
3. The test was performed in 966 Chamber No. H.
4. The FCC Site Registration No. is 797305.
5. The CANADA Site Registration No. is IC 7450H-3.



A D T

For above 1GHz: Test date: Nov. 30, 2011

DESCRIPTION & MANUFACTURER	MODEL NO.	SERIAL NO.	CALIBRATED DATE	CALIBRATED UNTIL
Agilent Spectrum Analyzer	E4446A	MY48250254	July 12, 2011	July 11, 2012
Agilent Pre-Selector	N9039A	MY46520311	July 12, 2011	July 11, 2012
Agilent Signal Generator	N5181A	MY49060517	July 12, 2011	July 11, 2012
Mini-Circuits Pre-Amplifier	ZFL-1000VH2B	AMP-ZFL-03	Nov. 15, 2011	Nov. 14, 2012
Agilent Pre-Amplifier	8449B	3008A02578	July 04, 2011	July 03, 2012
SPACEK LABS	SLKKa-48-6	9K16	Nov. 15, 2011	Nov. 14, 2012
SCHWARZBECK Trilog Broadband Antenna	VULB 9168	9168-360	Apr. 14, 2011	Apr. 13, 2012
AISI Horn_Antenna	AIH.8018	0000320091110	Nov. 14, 2011	Nov. 13, 2012
SCHWARZBECK Horn_Antenna	BBHA 9170	9170-424	Oct. 07, 2011	Oct. 06, 2012
RF CABLE	NA	RF104-201 RF104-203 RF104-204	Dec. 27, 2010	Dec. 26, 2011
RF Cable	NA	CHGCAB_001	Oct. 07, 2011	Oct. 06, 2012
Software	ADT_Radiated_V8.7.05	NA	NA	NA
CT Antenna Tower & Turn Table	NA	NA	NA	NA

- Note: 1. The calibration interval of the above test instruments is 12 months and the calibrations are traceable to NML/ROC and NIST/USA.
2. The horn antenna, preamplifier (model: 8449B) are used only for the measurement of emission frequency above 1GHz if tested.
3. The test was performed in 966 Chamber No. G.
4. The FCC Site Registration No. is 966073.
5. The VCCI Site Registration No. is G-137.
6. The CANADA Site Registration No. is IC 7450H-2.

5.2.3 TEST PROCEDURES

- a. The EUT was placed on the top of a rotating table 0.8 meters above the ground at a 3 meter chamber room. The table was rotated 360 degrees to determine the position of the highest radiation.
- b. The EUT was set 3 meters away from the interference-receiving antenna, which was mounted on the top of a variable-height antenna tower.
- c. The height of antenna is varied from one meter to four meters above the ground to determine the maximum value of the field strength. Both horizontal and vertical polarizations of the antenna are set to make the measurement.
- d. For each suspected emission, the EUT was arranged to its worst case and then the antenna was tuned to heights from 1 meter to 4 meters and the rotatable table was turned from 0 degrees to 360 degrees to find the maximum reading.
- e. The test-receiver system was set to quasi-peak detect function and specified bandwidth with maximum hold mode when the test frequency is below 1 GHz.
- f. The test-receiver system was set to peak and average detect function and specified bandwidth with maximum hold mode when the test frequency is above 1 GHz. If the peak reading value also meets average limit, measurement with the average detector is unnecessary.

NOTE:

1. The resolution bandwidth and video bandwidth of test receiver/spectrum analyzer is 120kHz for Quasi-peak detection (QP) at frequency below 1GHz.
2. The resolution bandwidth of test receiver/spectrum analyzer is 1 MHz and the video bandwidth is 3 MHz for Peak detection (PK) at frequency above 1GHz.
3. The resolution bandwidth of test receiver/spectrum analyzer is 1 MHz and the video bandwidth is 10 Hz for Average detection (AV) at frequency above 1GHz.

5.2.4 DEVIATION FROM TEST STANDARD

No deviation

5.2.5 TEST SETUP

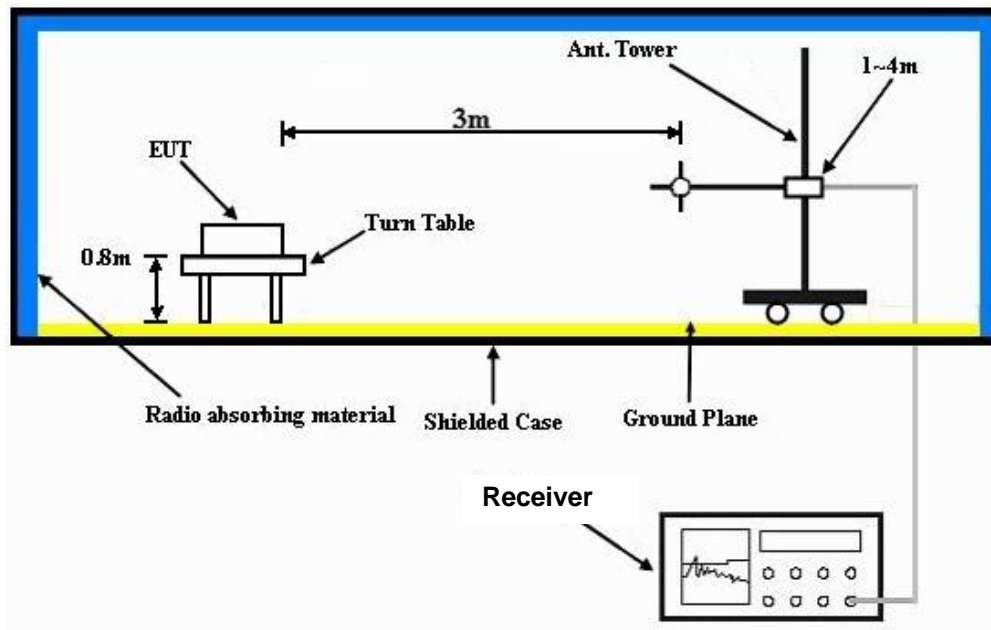

For the actual test configuration, please refer to the related item – Photographs of the Test Configuration.

5.2.6 EUT OPERATING CONDITIONS

Same as the 4.1.6



5.2.7 TEST RESULTS

BELOW 1GHz WORST-CASE DATA : 802.11a OFDM MODULATION

EUT TEST CONDITION		MEASUREMENT DETAIL	
CHANNEL	Channel 157	FREQUENCY RANGE	Below 1000MHz
INPUT POWER	DC 3.3V	DETECTOR FUNCTION	Quasi-Peak
ENVIRONMENTAL CONDITIONS	18deg. C, 64%RH	TESTED BY	Nick Chang

ANTENNA POLARITY & TEST DISTANCE: HORIZONTAL AT 3 M								
NO.	FREQ. (MHz)	EMISSION LEVEL (dBuV/m)	LIMIT (dBuV/m)	MARGIN (dB)	ANTENNA HEIGHT (m)	TABLE ANGLE (Degree)	RAW VALUE (dBuV)	CORRECTION FACTOR (dB/m)
1	34.03	24.2 QP	40.0	-15.8	1.50 H	276	10.87	13.36
2	161.09	30.8 QP	43.5	-12.7	1.50 H	193	16.34	14.45
3	238.07	32.3 QP	46.0	-13.7	1.00 H	35	19.49	12.82
4	360.04	31.6 QP	46.0	-14.4	1.00 H	175	14.82	16.75
5	480.01	30.4 QP	46.0	-15.6	1.50 H	251	10.86	19.58
6	720.05	29.4 QP	46.0	-16.6	1.00 H	237	5.86	23.56
7	845.70	35.8 QP	46.0	-10.3	1.00 H	52	9.59	26.16
ANTENNA POLARITY & TEST DISTANCE: VERTICAL AT 3 M								
NO.	FREQ. (MHz)	EMISSION LEVEL (dBuV/m)	LIMIT (dBuV/m)	MARGIN (dB)	ANTENNA HEIGHT (m)	TABLE ANGLE (Degree)	RAW VALUE (dBuV)	CORRECTION FACTOR (dB/m)
1	47.41	27.0 QP	40.0	-13.0	1.00 V	244	12.69	14.34
2	155.05	33.1 QP	43.5	-10.5	1.00 V	267	18.46	14.59
3	238.07	26.8 QP	46.0	-19.2	1.00 V	182	13.99	12.82
4	426.48	37.1 QP	46.0	-8.9	1.00 V	360	18.79	18.31
5	599.73	32.2 QP	46.0	-13.8	1.00 V	114	9.93	22.24
6	747.88	30.4 QP	46.0	-15.6	1.00 V	171	6.20	24.20
7	848.18	33.9 QP	46.0	-12.1	1.00 V	289	7.72	26.19

- REMARKS:**
1. Emission level (dBuV/m) = Raw Value (dBuV) + Correction Factor (dB/m).
 2. Correction Factor (dB/m) = Antenna Factor (dB/m) + Cable Factor (dB).
 3. The other emission levels were very low against the limit.
 4. Margin value = Emission level – Limit value.



A D T

ABOVE 1GHz WORST-CASE DATA

802.11a OFDM MODULATION

EUT TEST CONDITION		MEASUREMENT DETAIL	
CHANNEL	Channel 149	FREQUENCY RANGE	1 ~ 40GHz
INPUT POWER	DC 3.3V	DETECTOR FUNCTION	Peak (PK) Average (AV)
ENVIRONMENTAL CONDITIONS	21deg. C, 66%RH	TESTED BY	Kent Liu

ANTENNA POLARITY & TEST DISTANCE: HORIZONTAL AT 3 M

NO.	FREQ. (MHz)	EMISSION LEVEL (dBuV/m)	LIMIT (dBuV/m)	MARGIN (dB)	ANTENNA HEIGHT (m)	TABLE ANGLE (Degree)	RAW VALUE (dBuV)	CORRECTION FACTOR (dB/m)
1	*5745.00	98.4 PK			1.02 H	59	56.85	41.55
2	*5745.00	85.4 AV			1.02 H	59	43.85	41.55
3	11490.00	55.2 PK	74.0	-18.8	1.31 H	6	7.49	47.71
4	11490.00	44.4 AV	54.0	-9.6	1.31 H	6	-3.31	47.71

ANTENNA POLARITY & TEST DISTANCE: VERTICAL AT 3 M

NO.	FREQ. (MHz)	EMISSION LEVEL (dBuV/m)	LIMIT (dBuV/m)	MARGIN (dB)	ANTENNA HEIGHT (m)	TABLE ANGLE (Degree)	RAW VALUE (dBuV)	CORRECTION FACTOR (dB/m)
1	*5745.00	114.4 PK			1.32 V	101	72.85	41.55
2	*5745.00	93.9 AV			1.32 V	101	52.35	41.55
3	11490.00	56.0 PK	74.0	-18.0	1.45 V	318	8.29	47.71
4	11490.00	45.3 AV	54.0	-8.7	1.45 V	318	-2.41	47.71

- REMARKS:**
1. Emission level (dBuV/m) = Raw Value (dBuV) + Correction Factor (dB/m).
 2. Correction Factor (dB/m) = Antenna Factor (dB/m) + Cable Factor (dB).
 3. The other emission levels were very low against the limit.
 4. Margin value = Emission level – Limit value.
 5. “ * “: Fundamental frequency.
 6. The limit value is defined as per 15.247.



A D T

EUT TEST CONDITION		MEASUREMENT DETAIL	
CHANNEL	Channel 157	FREQUENCY RANGE	1 ~ 40GHz
INPUT POWER	DC 3.3V	DETECTOR FUNCTION	Peak (PK) Average (AV)
ENVIRONMENTAL CONDITIONS	21deg. C, 66%RH	TESTED BY	Kent Liu

ANTENNA POLARITY & TEST DISTANCE: HORIZONTAL AT 3 M								
NO.	FREQ. (MHz)	EMISSION LEVEL (dBuV/m)	LIMIT (dBuV/m)	MARGIN (dB)	ANTENNA HEIGHT (m)	TABLE ANGLE (Degree)	RAW VALUE (dBuV)	CORRECTION FACTOR (dB/m)
1	*5785.00	97.9 PK			1.02 H	67	56.22	41.68
2	*5785.00	84.9 AV			1.02 H	67	43.22	41.68
3	11570.00	55.0 PK	74.0	-19.0	1.36 H	12	7.25	47.75
4	11570.00	44.1 AV	54.0	-9.9	1.36 H	12	-3.65	47.75

ANTENNA POLARITY & TEST DISTANCE: VERTICAL AT 3 M								
NO.	FREQ. (MHz)	EMISSION LEVEL (dBuV/m)	LIMIT (dBuV/m)	MARGIN (dB)	ANTENNA HEIGHT (m)	TABLE ANGLE (Degree)	RAW VALUE (dBuV)	CORRECTION FACTOR (dB/m)
1	*5785.00	114.4 PK			1.26 V	106	72.72	41.68
2	*5785.00	94.1 AV			1.26 V	106	52.42	41.68
3	11570.00	55.7 PK	74.0	-18.3	1.51 V	307	7.95	47.75
4	11570.00	44.9 AV	54.0	-9.1	1.51 V	307	-2.85	47.75

- REMARKS:**
1. Emission level (dBuV/m) = Raw Value (dBuV) + Correction Factor (dB/m).
 2. Correction Factor (dB/m) = Antenna Factor (dB/m) + Cable Factor (dB).
 3. The other emission levels were very low against the limit.
 4. Margin value = Emission level – Limit value.
 5. “ * ”: Fundamental frequency.
 6. The limit value is defined as per 15.247.



A D T

EUT TEST CONDITION		MEASUREMENT DETAIL	
CHANNEL	Channel 165	FREQUENCY RANGE	1 ~ 40GHz
INPUT POWER	DC 3.3V	DETECTOR FUNCTION	Peak (PK) Average (AV)
ENVIRONMENTAL CONDITIONS	21deg. C, 66%RH	TESTED BY	Kent Liu

ANTENNA POLARITY & TEST DISTANCE: HORIZONTAL AT 3 M								
NO.	FREQ. (MHz)	EMISSION LEVEL (dBuV/m)	LIMIT (dBuV/m)	MARGIN (dB)	ANTENNA HEIGHT (m)	TABLE ANGLE (Degree)	RAW VALUE (dBuV)	CORRECTION FACTOR (dB/m)
1	*5825.00	98.1 PK			1.00 H	75	56.32	41.78
2	*5825.00	85.1 AV			1.00 H	75	43.32	41.78
3	11650.00	55.2 PK	74.0	-18.8	1.26 H	5	7.37	47.83
4	11650.00	44.2 AV	54.0	-9.8	1.26 H	5	-3.63	47.83

ANTENNA POLARITY & TEST DISTANCE: VERTICAL AT 3 M								
NO.	FREQ. (MHz)	EMISSION LEVEL (dBuV/m)	LIMIT (dBuV/m)	MARGIN (dB)	ANTENNA HEIGHT (m)	TABLE ANGLE (Degree)	RAW VALUE (dBuV)	CORRECTION FACTOR (dB/m)
1	*5825.00	114.3 PK			1.21 V	100	72.52	41.78
2	*5825.00	93.8 AV			1.21 V	100	52.02	41.78
3	11650.00	56.3 PK	74.0	-17.7	1.49 V	304	8.47	47.83
4	11650.00	45.7 AV	54.0	-8.3	1.49 V	304	-2.13	47.83

- REMARKS:**
1. Emission level (dBuV/m) = Raw Value (dBuV) + Correction Factor (dB/m).
 2. Correction Factor (dB/m) = Antenna Factor (dB/m) + Cable Factor (dB).
 3. The other emission levels were very low against the limit.
 4. Margin value = Emission level – Limit value.
 5. “ * ”: Fundamental frequency.
 6. The limit value is defined as per 15.247.



A D T

802.11n (20MHz) OFDM MODULATION

EUT TEST CONDITION		MEASUREMENT DETAIL	
CHANNEL	Channel 149	FREQUENCY RANGE	1 ~ 40GHz
INPUT POWER	DC 3.3V	DETECTOR FUNCTION	Peak (PK) Average (AV)
ENVIRONMENTAL CONDITIONS	21deg. C, 66%RH	TESTED BY	Kent Liu

ANTENNA POLARITY & TEST DISTANCE: HORIZONTAL AT 3 M

NO.	FREQ. (MHz)	EMISSION LEVEL (dBuV/m)	LIMIT (dBuV/m)	MARGIN (dB)	ANTENNA HEIGHT (m)	TABLE ANGLE (Degree)	RAW VALUE (dBuV)	CORRECTION FACTOR (dB/m)
1	*5745.00	102.6 PK			1.00 H	84	61.05	41.55
2	*5745.00	88.8 AV			1.00 H	84	47.25	41.55
3	11490.00	55.3 PK	74.0	-18.7	1.26 H	15	7.59	47.71
4	11490.00	44.4 AV	54.0	-9.6	1.26 H	15	-3.31	47.71

ANTENNA POLARITY & TEST DISTANCE: VERTICAL AT 3 M

NO.	FREQ. (MHz)	EMISSION LEVEL (dBuV/m)	LIMIT (dBuV/m)	MARGIN (dB)	ANTENNA HEIGHT (m)	TABLE ANGLE (Degree)	RAW VALUE (dBuV)	CORRECTION FACTOR (dB/m)
1	*5745.00	113.3 PK			1.22 V	101	71.75	41.55
2	*5745.00	98.0 AV			1.22 V	101	56.45	41.55
3	11490.00	56.8 PK	74.0	-17.2	1.53 V	309	9.09	47.71
4	11490.00	45.9 AV	54.0	-8.1	1.53 V	309	-1.81	47.71

- REMARKS:**
1. Emission level (dBuV/m) = Raw Value (dBuV) + Correction Factor (dB/m).
 2. Correction Factor (dB/m) = Antenna Factor (dB/m) + Cable Factor (dB).
 3. The other emission levels were very low against the limit.
 4. Margin value = Emission level – Limit value.
 5. “ * “: Fundamental frequency.
 6. The limit value is defined as per 15.247.



A D T

EUT TEST CONDITION		MEASUREMENT DETAIL	
CHANNEL	Channel 157	FREQUENCY RANGE	1 ~ 40GHz
INPUT POWER	DC 3.3V	DETECTOR FUNCTION	Peak (PK) Average (AV)
ENVIRONMENTAL CONDITIONS	21deg. C, 66%RH	TESTED BY	Kent Liu

ANTENNA POLARITY & TEST DISTANCE: HORIZONTAL AT 3 M								
NO.	FREQ. (MHz)	EMISSION LEVEL (dBuV/m)	LIMIT (dBuV/m)	MARGIN (dB)	ANTENNA HEIGHT (m)	TABLE ANGLE (Degree)	RAW VALUE (dBuV)	CORRECTION FACTOR (dB/m)
1	*5785.00	102.7 PK			1.00 H	91	61.02	41.68
2	*5785.00	89.0 AV			1.00 H	91	47.32	41.68
3	11570.00	55.6 PK	74.0	-18.4	1.32 H	20	7.85	47.75
4	11570.00	44.7 AV	54.0	-9.3	1.32 H	20	-3.05	47.75

ANTENNA POLARITY & TEST DISTANCE: VERTICAL AT 3 M								
NO.	FREQ. (MHz)	EMISSION LEVEL (dBuV/m)	LIMIT (dBuV/m)	MARGIN (dB)	ANTENNA HEIGHT (m)	TABLE ANGLE (Degree)	RAW VALUE (dBuV)	CORRECTION FACTOR (dB/m)
1	*5785.00	113.6 PK			1.19 V	112	71.92	41.68
2	*5785.00	98.4 AV			1.19 V	112	56.72	41.68
3	11570.00	56.5 PK	74.0	-17.5	1.56 V	308	8.75	47.75
4	11570.00	45.6 AV	54.0	-8.4	1.56 V	308	-2.15	47.75

- REMARKS:**
1. Emission level (dBuV/m) = Raw Value (dBuV) + Correction Factor (dB/m).
 2. Correction Factor (dB/m) = Antenna Factor (dB/m) + Cable Factor (dB).
 3. The other emission levels were very low against the limit.
 4. Margin value = Emission level – Limit value.
 5. “ * “: Fundamental frequency.
 6. The limit value is defined as per 15.247.



A D T

EUT TEST CONDITION		MEASUREMENT DETAIL	
CHANNEL	Channel 165	FREQUENCY RANGE	1 ~ 40GHz
INPUT POWER	DC 3.3V	DETECTOR FUNCTION	Peak (PK) Average (AV)
ENVIRONMENTAL CONDITIONS	21deg. C, 66%RH	TESTED BY	Kent Liu

ANTENNA POLARITY & TEST DISTANCE: HORIZONTAL AT 3 M								
NO.	FREQ. (MHz)	EMISSION LEVEL (dBuV/m)	LIMIT (dBuV/m)	MARGIN (dB)	ANTENNA HEIGHT (m)	TABLE ANGLE (Degree)	RAW VALUE (dBuV)	CORRECTION FACTOR (dB/m)
1	*5825.00	102.8 PK			1.00 H	84	61.02	41.78
2	*5825.00	89.2 AV			1.00 H	84	47.42	41.78
3	11650.00	56.2 PK	74.0	-17.8	1.37 H	10	8.37	47.83
4	11650.00	45.1 AV	54.0	-8.9	1.37 H	10	-2.73	47.83

ANTENNA POLARITY & TEST DISTANCE: VERTICAL AT 3 M								
NO.	FREQ. (MHz)	EMISSION LEVEL (dBuV/m)	LIMIT (dBuV/m)	MARGIN (dB)	ANTENNA HEIGHT (m)	TABLE ANGLE (Degree)	RAW VALUE (dBuV)	CORRECTION FACTOR (dB/m)
1	*5825.00	113.4 PK			1.19 V	107	71.62	41.78
2	*5825.00	98.0 AV			1.19 V	107	56.22	41.78
3	11650.00	56.8 PK	74.0	-17.2	1.51 V	302	8.97	47.83
4	11650.00	46.0 AV	54.0	-8.0	1.51 V	302	-1.83	47.83

- REMARKS:**
1. Emission level (dBuV/m) = Raw Value (dBuV) + Correction Factor (dB/m).
 2. Correction Factor (dB/m) = Antenna Factor (dB/m) + Cable Factor (dB).
 3. The other emission levels were very low against the limit.
 4. Margin value = Emission level – Limit value.
 5. “ * ”: Fundamental frequency.
 6. The limit value is defined as per 15.247.

5.3 6dB BANDWIDTH MEASUREMENT

5.3.1 LIMITS OF 6dB BANDWIDTH MEASUREMENT

The minimum of 6dB Bandwidth Measurement is 0.5 MHz.

5.3.2 TEST INSTRUMENTS

Test date: Nov. 23, 2011

DESCRIPTION & MANUFACTURER	MODEL NO.	SERIAL NO.	CALIBRATED DATE	CALIBRATED UNTIL
R&S Spectrum Analyzer	FSP40	100036	Dec. 08, 2010	Dec. 07, 2011

NOTE: The calibration interval of the above test instruments is 12 months and the calibrations are traceable to NML/ROC and NIST/USA.

5.3.3 TEST PROCEDURE

The transmitter output was connected to the spectrum analyzer through an attenuator. The bandwidth of the fundamental frequency was measured by spectrum analyzer with 100kHz RBW and 300kHz VBW. The 6dB bandwidth is defined as the total spectrum the power of which is higher than peak power minus 6dB.

5.3.4 DEVIATION FROM TEST STANDARD

No deviation

5.3.5 TEST SETUP

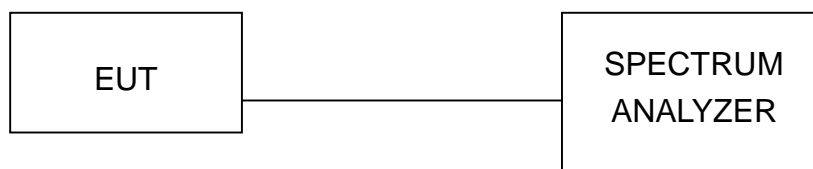

5.3.6 EUT OPERATING CONDITIONS

The software provided by client to enable the EUT under transmission condition continuously at lowest, middle and highest channel frequencies individually.

5.3.7 TEST RESULTS

802.11a OFDM MODULATION:

CHANNEL	CHANNEL FREQUENCY (MHz)	6dB BANDWIDTH (MHz)	MINIMUM LIMIT (MHz)	PASS / FAIL
149	5745	16.03	0.5	PASS
157	5785	15.13	0.5	PASS
165	5825	16.31	0.5	PASS

CH165

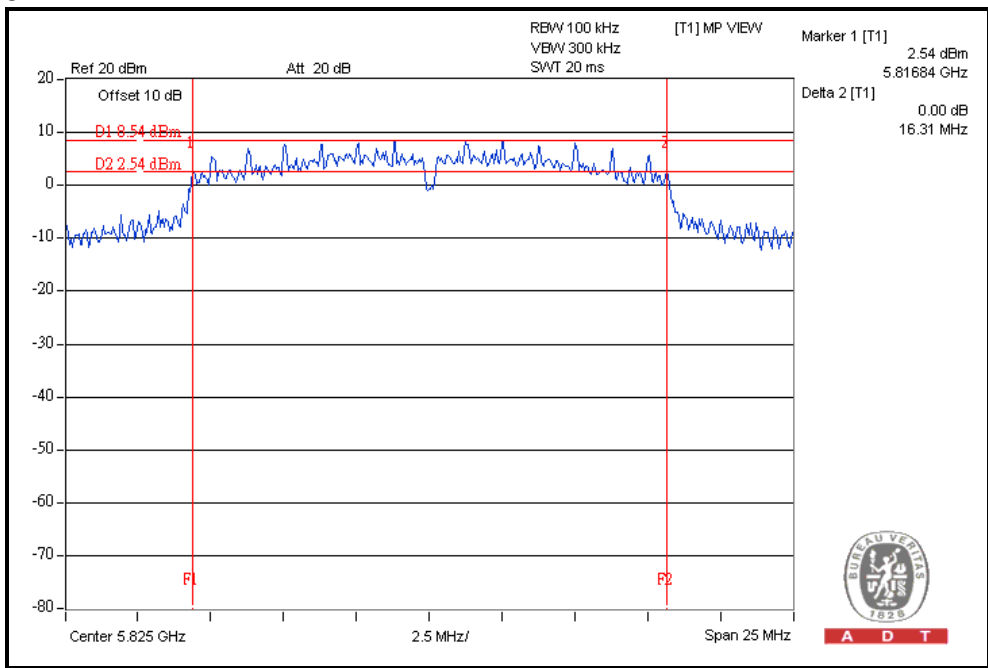



A D T

802.11n (20MHz) OFDM MODULATION:

CHANNEL	CHANNEL FREQUENCY (MHz)	6dB BANDWIDTH (MHz)	MINIMUM LIMIT (MHz)	PASS / FAIL
149	5745	15.20	0.5	PASS
157	5785	15.77	0.5	PASS
165	5825	15.15	0.5	PASS

CH157

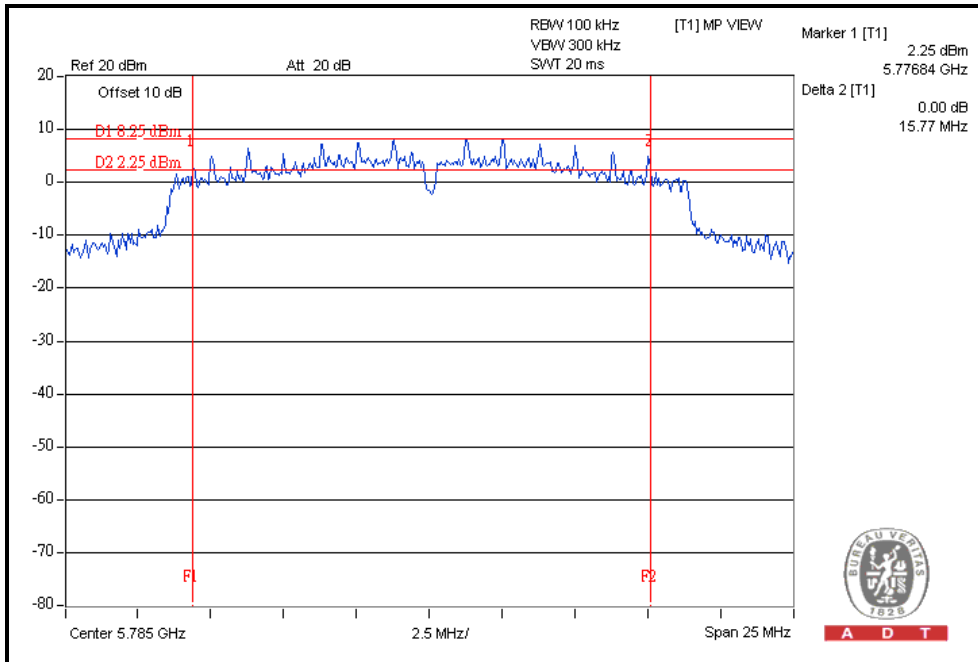

5.4 MAXIMUM PEAK OUTPUT POWER

5.4.1 LIMITS OF MAXIMUM PEAK OUTPUT POWER MEASUREMENT

The Maximum Peak Output Power Measurement is 30dBm.

5.4.2 INSTRUMENTS

Test date: Nov. 23, 2011

DESCRIPTION & MANUFACTURER	MODEL NO.	SERIAL NO.	CALIBRATED DATE	CALIBRATED UNTIL
Peak Power Meter	ML2495A	0824006	May 04, 2011	May 03, 2012
Power Sensor	MA2411B	0738172	May 03, 2011	May 02, 2012

NOTE: The calibration interval of the above test instruments is 12 months and the calibrations are traceable to NML/ROC and NIST/USA.

5.4.3 TEST PROCEDURES

1. The transmitter output was connected to the power meter through an attenuator; the bandwidth of the fundamental frequency was measured with the power meter.
2. Record the power level.

5.4.4 DEVIATION FROM TEST STANDARD

No deviation

5.4.5 TEST SETUP

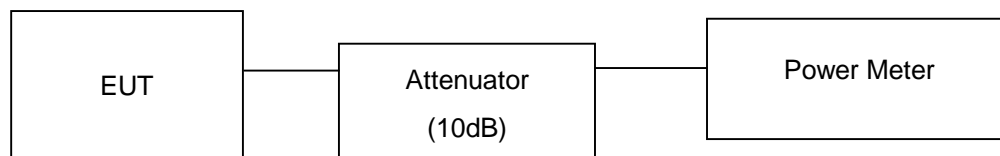

5.4.6 EUT OPERATING CONDITIONS

Same as Item 4.3.6



A D T

5.4.7 TEST RESULTS

802.11a OFDM MODULATION:

CHANNEL	CHANNEL FREQUENCY (MHz)	PEAK POWER OUTPUT (mW)	PEAK POWER OUTPUT (dBm)	PEAK POWER LIMIT (dBm)	PASS / FAIL
149	5745	154.9	21.9	30	PASS
157	5785	158.5	22.0	30	PASS
165	5825	154.9	21.9	30	PASS

Note: Output Power = Measurement PWR + Trace loss (1.3dB)

802.11n (20MHz) OFDM MODULATION:

CHANNEL	CHANNEL FREQUENCY (MHz)	PEAK POWER OUTPUT (mW)	PEAK POWER OUTPUT (dBm)	PEAK POWER LIMIT (dBm)	PASS / FAIL
149	5745	151.4	21.8	30	PASS
157	5785	154.9	21.9	30	PASS
165	5825	151.4	21.8	30	PASS

Note: Output Power = Measurement PWR + Trace loss (1.3dB)

5.5 POWER SPECTRAL DENSITY MEASUREMENT

5.5.1 LIMITS OF POWER SPECTRAL DENSITY MEASUREMENT

The Maximum of Power Spectral Density Measurement is 8dBm.

5.5.2 TEST INSTRUMENTS

Test date: Nov. 23, 2011

DESCRIPTION & MANUFACTURER	MODEL NO.	SERIAL NO.	CALIBRATED DATE	CALIBRATED UNTIL
R&S Spectrum Analyzer	FSP40	100036	Dec. 08, 2010	Dec. 07, 2011

NOTE: The calibration interval of the above test instruments is 12 months and the calibrations are traceable to NML/ROC and NIST/USA.

5.5.3 TEST PROCEDURE

The transmitter output was connected to the spectrum analyzer through an attenuator, the bandwidth of the fundamental frequency was measured with the spectrum analyzer using 3 kHz RBW and 30 kHz VBW, set sweep time = span/3 kHz. The power spectral density was measured and recorded.

The sweep time is allowed to be longer than span/3 kHz for a full response of the mixer in the spectrum analyzer.

5.5.4 DEVIATION FROM TEST STANDARD

No deviation

5.5.5 TEST SETUP



5.5.6 EUT OPERATING CONDITION

Same as Item 4.3.6



A D T

5.5.7 TEST RESULTS

802.11a OFDM MODULATION:

CHANNEL	FREQUENCY (MHz)	PSD (dBm/3kHz)	Limit (dBm/3kHz)	PASS / FAIL
149	5745	-5.8	8	PASS
157	5785	-6.7	8	PASS
165	5825	-5.9	8	PASS

Note: PSD = Measurement PSD + Trace loss (1.3dB)

CH149

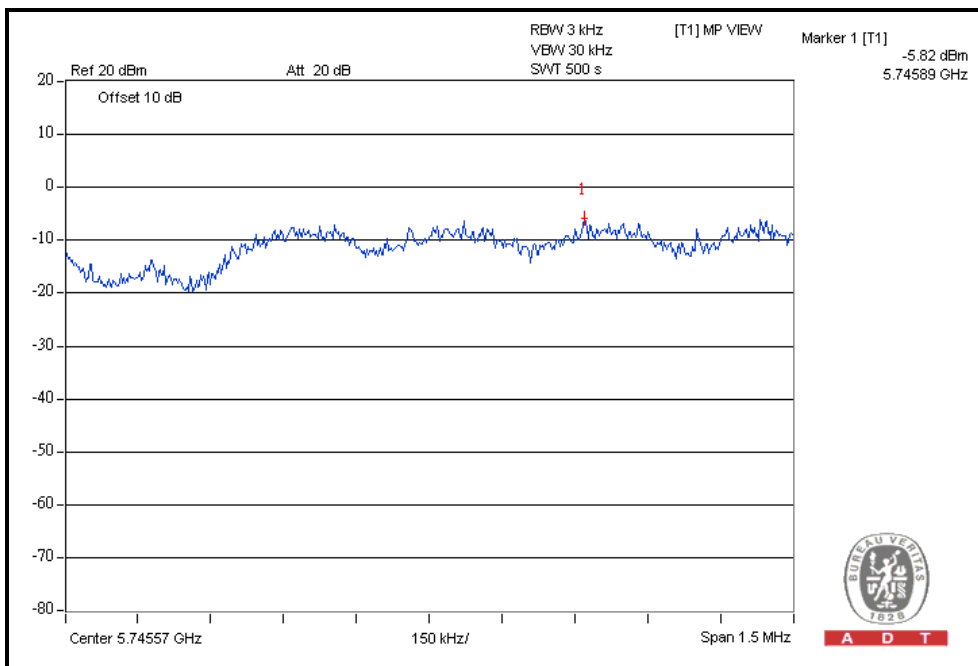



A D T

802.11n (20MHz) OFDM MODULATION:

CHANNEL	FREQUENCY (MHz)	PSD (dBm/3kHz)	Limit (dBm/3kHz)	PASS / FAIL
149	5745	-7.1	8	PASS
157	5785	-6.8	8	PASS
165	5825	-7.4	8	PASS

Note: PSD = Measurement PSD + Trace loss (1.3dB)

CH157

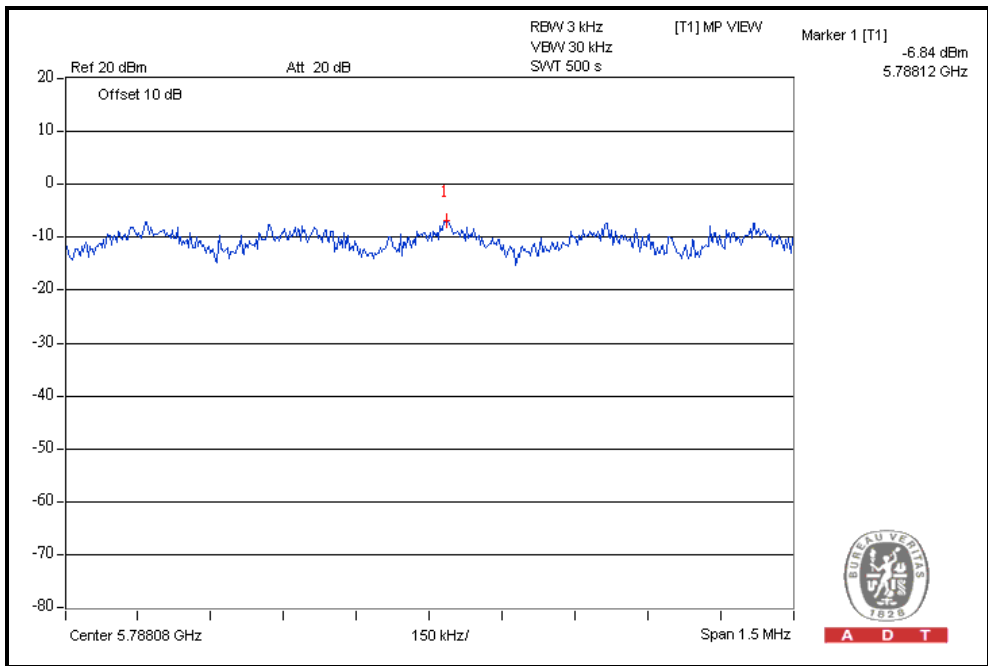

5.6 CONDUCTED OUT-BAND EMISSION MEASUREMENT

5.6.1 LIMITS OF CONDUCTED OUT-BAND EMISSION MEASUREMENT

Below -20dB of the highest emission level of operating band (in 100kHz Resolution Bandwidth).

5.6.2 TEST INSTRUMENTS

Test date: Nov. 23, 2011

DESCRIPTION & MANUFACTURER	MODEL NO.	SERIAL NO.	CALIBRATED DATE	CALIBRATED UNTIL
R&S Spectrum Analyzer	FSP40	100036	Dec. 08, 2010	Dec. 07, 2011

NOTE: The calibration interval of the above test instruments is 12 months and the calibrations are traceable to NML/ROC and NIST/USA.

5.6.3 TEST PROCEDURE

The transmitter output was connected to the spectrum analyzer via a low loss cable. Set RBW of spectrum analyzer to 100 kHz with suitable frequency span including 100MHz or 200MHz bandwidth from band edge. The band edges was measured and recorded.

5.6.4 DEVIATION FROM TEST STANDARD

No deviation

5.6.5 EUT OPERATING CONDITION

Same as Item 4.3.6

5.6.6 TEST RESULTS

The spectrum plots are attached on the following pages. D2 line indicates the highest level, D1 line indicates the 20dB offset below D2. It shows compliance with the requirement in part 15.247(d).

802.11a OFDM modulation

CH149

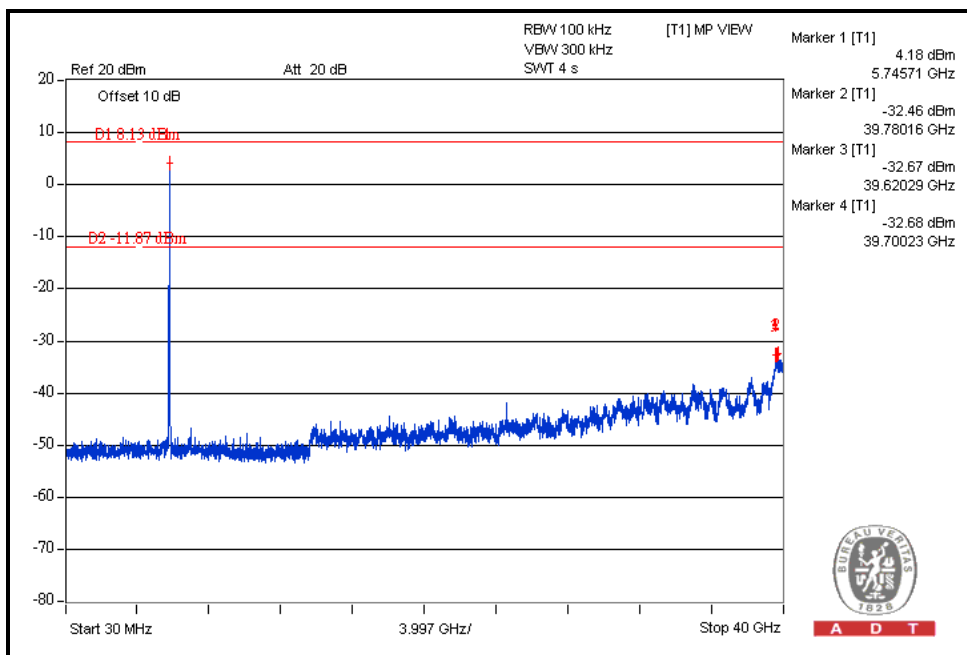
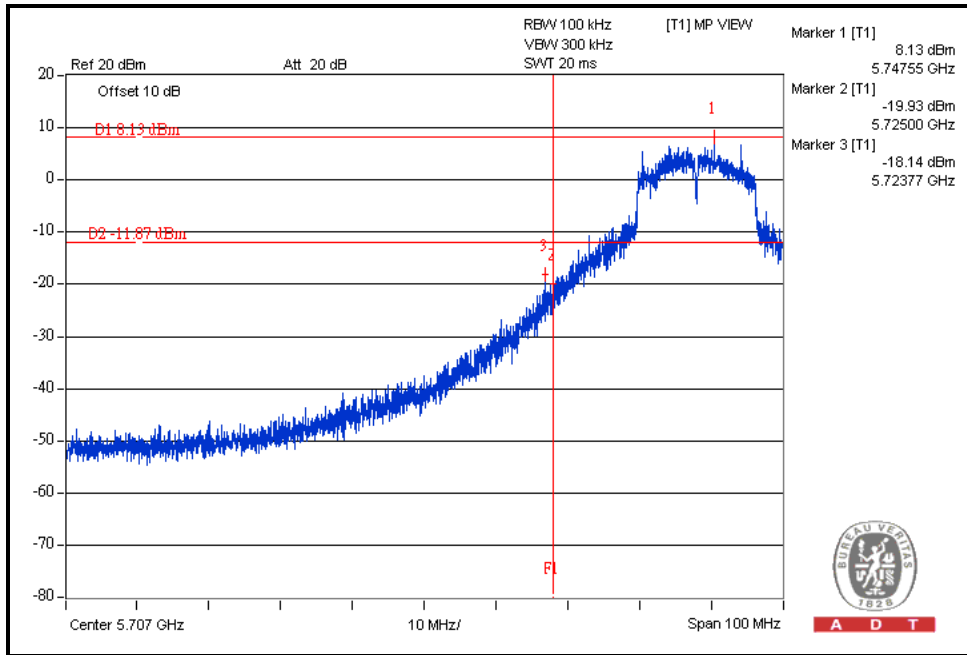



A D T

CH165

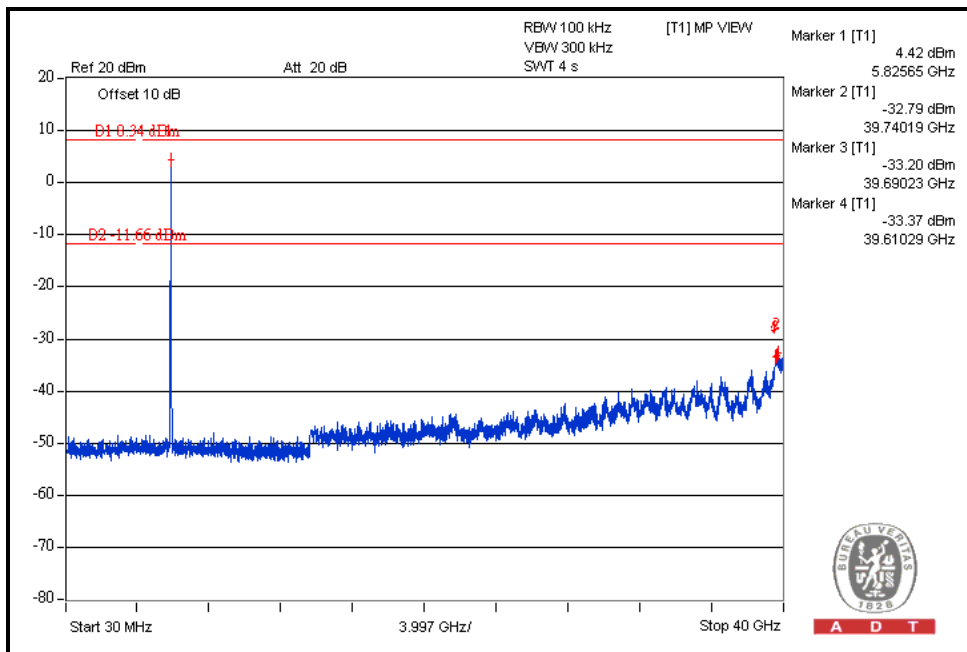
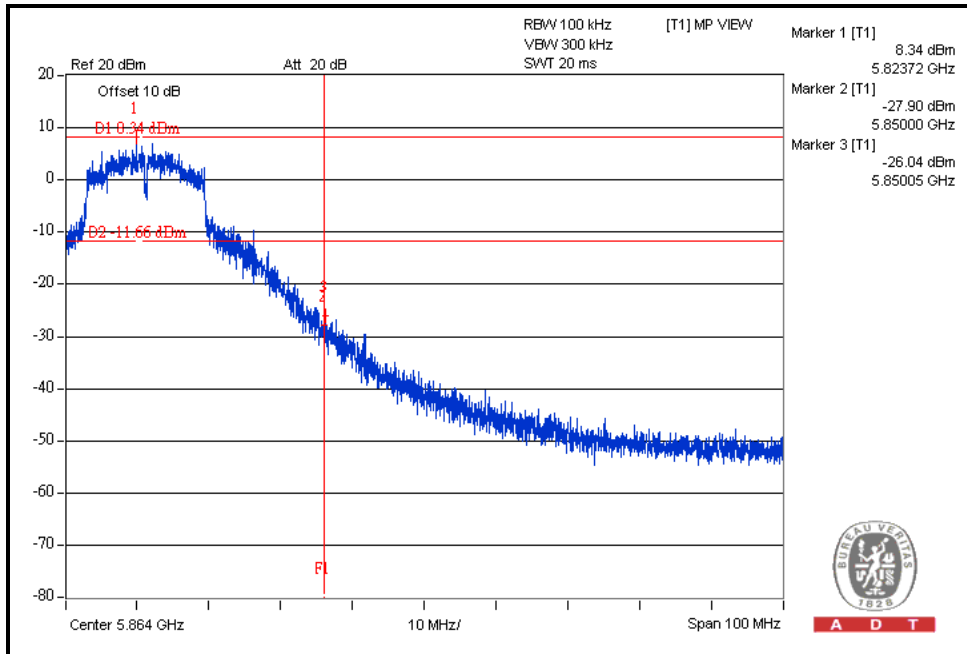



A D T

802.11n (20MHz) OFDM MODULATION:

CH149

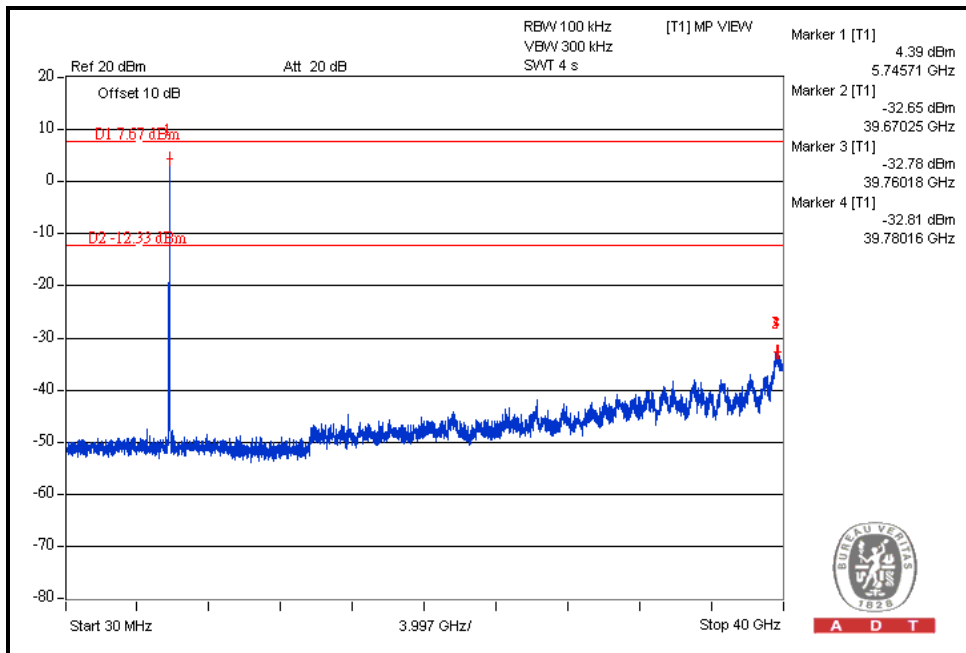
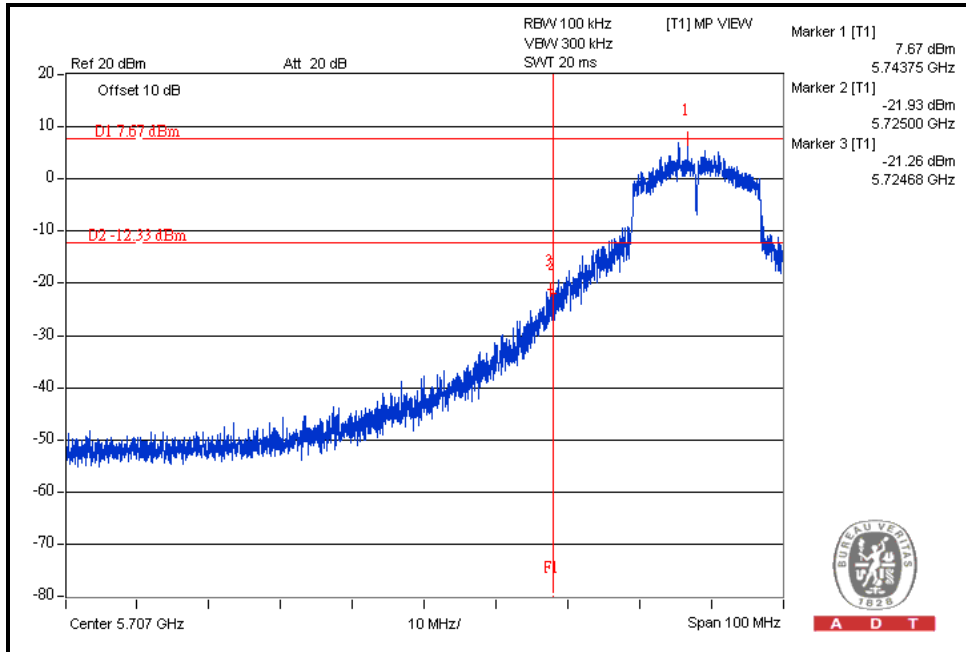



A D T

CH165

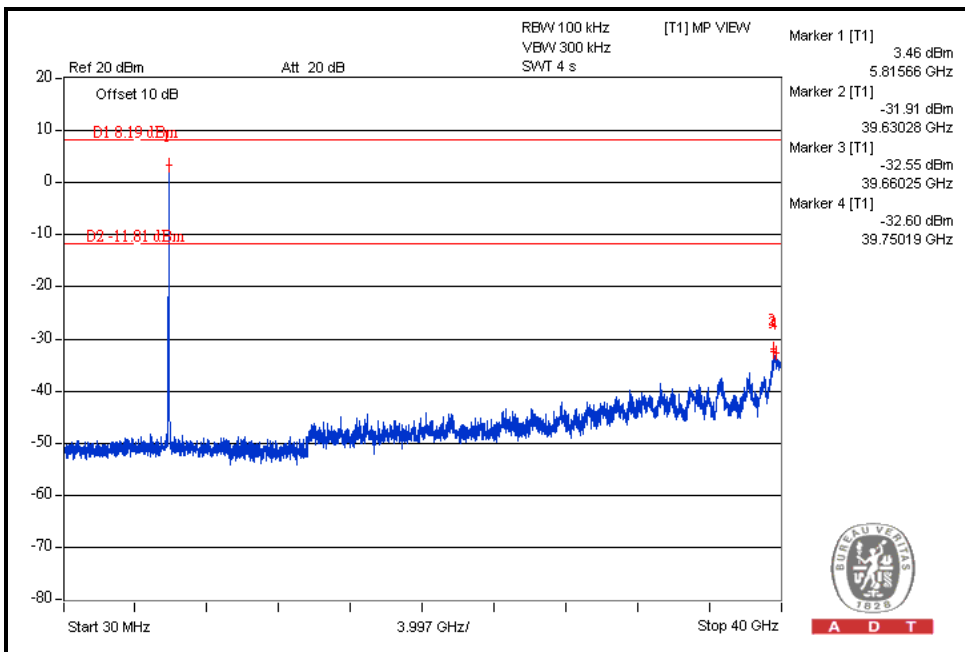
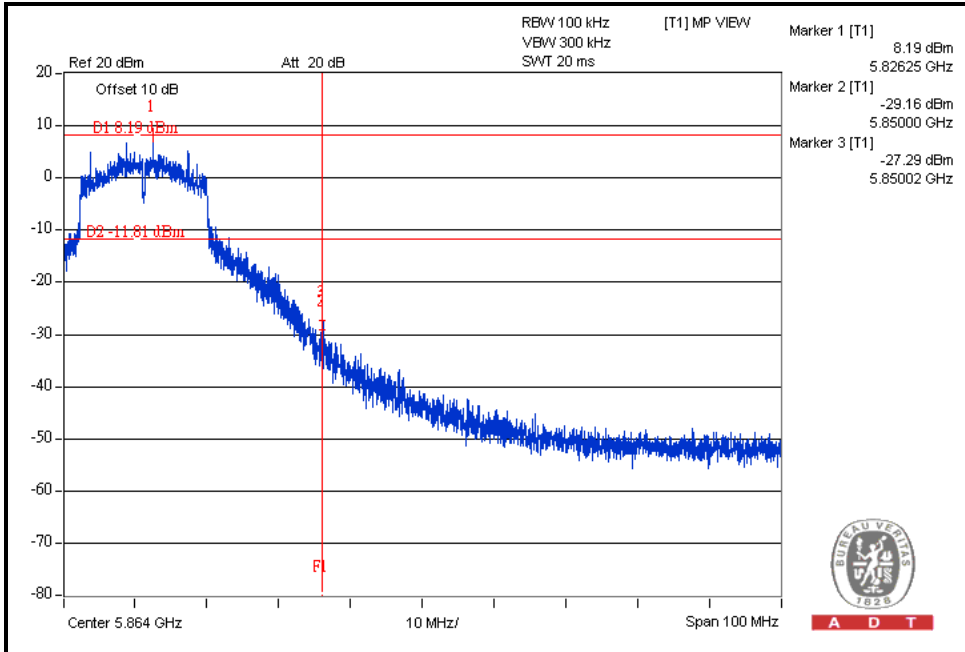



6. INFORMATION ON THE TESTING LABORATORIES

We, Bureau Veritas Consumer Products Services (H.K.) Ltd., Taoyuan Branch, were founded in 1988 to provide our best service in EMC, Radio, Telecom and Safety consultation. Our laboratories are accredited and approved according to ISO/IEC 17025.

Copies of accreditation and authorization certificates of our laboratories obtained from approval agencies can be downloaded from our web site:

www.adt.com.tw/index.5.phtml.

If you have any comments, please feel free to contact us at the following:

Linko EMC/RF Lab:

Tel: 886-2-26052180

Fax: 886-2-26052943

Hsin Chu EMC/RF Lab:

Tel: 886-3-5935343

Fax: 886-3-5935342

Hwa Ya EMC/RF/Safety/Telecom Lab:

Tel: 886-3-3183232

Fax: 886-3-3185050

Email: service.adt@tw.bureauveritas.com

Web Site: www.adt.com.tw

The address and road map of all our labs can be found in our web site also.



A D T

7.APPENDIX A - MODIFICATIONS RECORDERS FOR ENGINEERING CHANGES TO THE EUT BY THE LAB

No modifications were made to the EUT by the lab during the test.

--- END ---