



FCC RADIO TEST REPORT

FCC ID : UZ7-RTL10C1
Equipment : Tablet PC with Windows OS
Brand Name : Zebra
Model Name : RTL10C1
Applicant : Zebra Technologies Corporation
1 Zebra Plaza, Holtsville, NY 11742
Manufacturer : Zebra Technologies Corporation
1 Zebra Plaza, Holtsville, NY 11742
Standard : FCC 47 CFR Part 2, 27

The product was received on Dec. 15, 2021 and testing was performed from Dec. 21, 2021 to Jan. 29, 2022. We, Sporton International Inc. EMC & Wireless Communications Laboratory, would like to declare that the tested sample has been evaluated in accordance with the test procedures given in ANSI / TIA-603-E and has been in compliance with the applicable technical standards.

The test results in this partial report apply exclusively to the tested model / sample. Without written approval of Sporton International Inc. EMC & Wireless Communications Laboratory, the test report shall not be reproduced except in full.

Approved by: Louis Wu

Sporton International Inc. EMC & Wireless Communications Laboratory
No. 52, Huaya 1st Rd., Guishan Dist., Taoyuan City 333, Taiwan (R.O.C.)



Table of Contents

History of this test report.....	3
Summary of Test Result.....	4
1 General Description	5
1.1 Product Feature of Equipment Under Test.....	5
1.2 Product Specification of Equipment Under Test.....	6
1.3 Modification of EUT	6
1.4 Maximum EIRP Power.....	6
1.5 Testing Location	7
1.6 Applicable Standards.....	8
2 Test Configuration of Equipment Under Test	9
2.1 Test Mode.....	9
2.2 Connection Diagram of Test System.....	10
2.3 Support Unit used in test configuration and system	10
2.4 Frequency List of Low/Middle/High Channels	10
3 Conducted Test Items.....	11
3.1 Measuring Instruments	11
3.2 Conducted Output Power and EIRP.....	12
4 Radiated Test Items	13
4.1 Measuring Instruments	13
4.2 Radiated Spurious Emission Measurement	15
5 List of Measuring Equipment.....	16
6 Uncertainty of Evaluation.....	17
Appendix A. Test Results of Conducted Test	
Appendix B. Test Results of Radiated Test	
Appendix C. Test Setup Photographs	



History of this test report

Report No.	Version	Description	Issued Date
FG181117H	01	Initial issue of report	Feb. 21, 2022



Summary of Test Result

Report Clause	Ref Std. Clause	Test Items	Result (PASS/FAIL)	Remark
3.2	§2.1046	Conducted Output Power	Reporting only	-
	§27.50 (j)(3)	Equivalent Isotropic Radiated Power (n77)	Pass	
-	§27.50 (j)(4)	Peak-to-Average Ratio	-	See Note
-	§2.1049	Occupied Bandwidth	-	See Note
-	§2.1051 §27.53 (l)(2)	Conducted Band Edge Measurement (n77)	-	See Note
-	§2.1051 §27.53 (l)(2)	Conducted Spurious Emission (n77)	-	See Note
-	§2.1055 §27.54	Frequency Stability Temperature & Voltage	-	See Note
4.2	§2.1051 §27.53 (l)(2)	Radiated Spurious Emission (n77)	Pass	Under limit 19.62 dB at 15162.000 MHz

Note: The module (Model: RM505Q-AE) makes no difference after verifying output power, this report reuses test data from the module report.

Declaration of Conformity:

- The test results (PASS/FAIL) with all measurement uncertainty excluded are presented in accordance with the regulation limits or requirements declared by manufacturers. It's means measurement values may risk exceeding the limit of regulation standards, if measurement uncertainty is include in test results.
- The measurement uncertainty please refer to this report "Uncertainty of Evaluation".

Comments and Explanations:

The product specifications of the EUT presented in the report are declared by the manufacturer who shall take full responsibility for the authenticity.

Reviewed by: Wei Chen

Report Producer: Amy Chen



1 General Description

1.1 Product Feature of Equipment Under Test

Product Feature	
Equipment	Tablet PC with Windows OS
Brand Name	Zebra
Model Name	RTL10C1
FCC ID	UZ7-RTL10C1
Sample 1	XPAD
Sample 2	XSLATE
EUT supports Radios application	WCDMA/HSPA/LTE/5G NR/NFC/GNSS WLAN 11a/b/g/n HT20/HT40 WLAN 11ac VHT20/VHT40/VHT80/VHT160 WLAN 11ax HE20/HE40/HE80/HE160 Bluetooth BR/EDR/LE
HW Version	EV
SW Version	Windows 10 Pro
MFD	18OCT21
EUT Stage	Identical Prototype

Remark: The above EUT's information was declared by manufacturer.

Specification of Accessories				
Adaptor with CLA cable	Brand Name	Zebra	Model Number	ADP-65JH HB
Battery	Brand Name	ZEBRA	Model Number	XLBM1
Power cord	Brand Name	Zebra	Model Number	450040

Supported Unit Used in Test Configuration and System				
Keyboard	Brand Name	Zebra	Model Number	L10-KB
98 Whr Extended Battery (Certified)	Brand Name	Zebra	Model Number	XLBE1
AEI LONG RANGE RFID MODULE	Brand Name	Zebra	Model Number	M6E-MICRO
PASSIVE SHORT STYLUS	Brand Name	Zebra	Model Number	440007
ET8X MPP 2.0 ACTIVE STYLUS WITH 5 REPLACEMENT TIPS. AAAA BATTERY INCLUDED	Brand Name	Zebra	Model Number	SG-ET8X-STYLUS1-01

1.2 Product Specification of Equipment Under Test

Product Specification is subject to this standard	
Tx/Rx Frequency	5G NR n77: 3705 MHz ~ 3975 MHz
Bandwidth	100MHz
Maximum Output Power to Antenna	5G NR n77: 26.18 dBm 5G NR n77_HPUE: 23.18 dBm
Antenna Type	Fixed Internal Antenna
Antenna Gain	<Aux.>: 5G NR n77: 0.38 dBi
Type of Modulation	PI/2 BPSK / QPSK / 16QAM / 64QAM / 256QAM

Remark: The above EUT's information was declared by manufacturer. Please refer to Comments and Explanations in report summary.

1.3 Modification of EUT

No modifications are made to the EUT during all test items.

1.4 Maximum EIRP Power

5G NR n77		PI/2 BPSK / QPSK		16QAM / 64QAM / 256QAM		
BW (MHz)	Frequency Range (MHz)	Maximum EIRP(W)	Maximum EIRP(W)	Maximum EIRP(W)	Maximum EIRP(W)	Maximum EIRP(W)
100	3750 ~ 3930	0.4529		0.3206		
5G NR n77_HPUE		PI/2 BPSK / QPSK		16QAM / 64QAM / 256QAM		
BW (MHz)	Frequency Range (MHz)	Maximum EIRP(W)	Maximum EIRP(W)	Maximum EIRP(W)	Maximum EIRP(W)	Maximum EIRP(W)
100	3750 ~ 3930	0.2270		0.2128		



1.5 Testing Location

Test Site	Sporton International Inc. EMC & Wireless Communications Laboratory
Test Site Location	No.52, Huaya 1st Rd., Guishan Dist., Taoyuan City 333, Taiwan (R.O.C.) TEL: +886-3-327-3456 FAX: +886-3-328-4978
Test Site No.	Sporton Site No. TH03-HY
Test Engineer	Sherry Wu
Temperature	22.3~22.7°C
Relative Humidity	48.7~53.3%

Test Site	Sporton International Inc. Wensan Laboratory
Test Site Location	No.58, Aly. 75, Ln. 564, Wenhua 3rd, Rd., Guishan Dist., Taoyuan City 333010, Taiwan (R.O.C.) TEL: +886-3-327-0868 FAX: +886-3-327-0855
Test Site No.	Sporton Site No. 03CH12-HY (TAF Code: 3786)
Test Engineer	Jack Cheng, Lance Chiang, and Chuan Chu
Temperature	22.3~26.4°C
Relative Humidity	58~66%
Remark	The Radiated Spurious Emission test item subcontracted to Sporton International Inc. Wensan Laboratory

Note: The test site complies with ANSI C63.4 2014 requirement.

FCC Designation No.: TW1190 and TW3786



1.6 Applicable Standards

According to the specifications of the manufacturer, the EUT must comply with the requirements of the following standards:

- ♦ ANSI C63.26-2015
- ♦ ANSI / TIA-603-E
- ♦ FCC 47 CFR Part 2, 27
- ♦ FCC KDB 971168 D01 Power Meas. License Digital Systems v03r01
- ♦ FCC KDB 412172 D01 Determining ERP and EIRP v01r01
- ♦ FCC KDB 414788 D01 Radiated Test Site v01r01.

Remark:

1. All test items were verified and recorded according to the standards and without any deviation during the test.
2. The TAF code is not including all the FCC KDB listed without accreditation.



2 Test Configuration of Equipment Under Test

2.1 Test Mode

Antenna port conducted and radiated test items listed below are performed according to KDB 971168 D01 Power Meas. License Digital Systems v03r01 with maximum output power.

For radiated measurement, the measured emission level of the EUT was maximized by rotating the EUT on a turntable, adjusting the orientation of the EUT and EUT antenna in three orthogonal axis (X: flat, Y: portrait, Z: landscape), and adjusting the measurement antenna orientation, following C63.26 exploratory test procedures and find Z Plane as worst plane.

Test Items	NR Band	Bandwidth (MHz)												Modulation					RB #			Test Channel			
		5	10	15	20	25	30	40	50	60	80	90	100	PI/2 BPSK	QPSK	16QAM	64QAM	256QAM	1	Half	Full	L	M	H	
Max. Output Power	n77	-				-	-						-	v	v	v	v	v	v	v	v	v	v	v	v
E.I.R.P	n77	-				-	-						-	v	v	v	v	v	v	Max. Power					
Radiated Spurious Emission	n77	-				-	-						-	v	v					v			v	v	v
Remark	<ol style="list-style-type: none"> The mark "v" means that this configuration is chosen for testing The mark "-" means that this bandwidth is not supported. The device is investigated from 30MHz to 10 times of fundamental signal for radiated spurious emission test under different RB size/offset and modulations in exploratory test. Subsequently, only the worst case emissions are reported. For radiated measurement, pre-scanned in two modes, DFT-s OFDM and CP OFDM. The worst cases (DFT-s OFDM) were recorded in this report, and the worst modes of FR1 and LTE for simultaneous transmission were verified and compliant. For Radiated Test Cases, the tests were performed with Sample 1. 																								

2.2 Connection Diagram of Test System

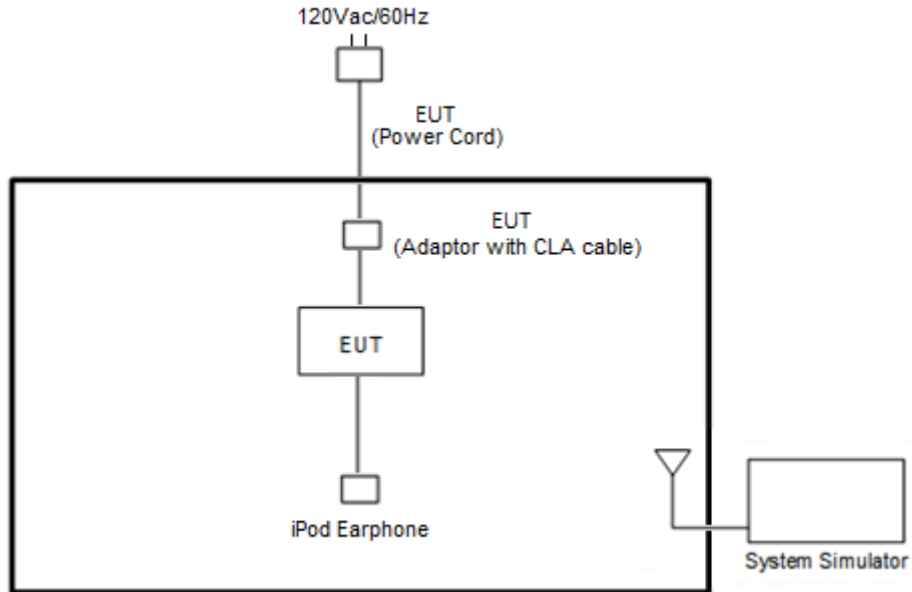

2.3 Support Unit used in test configuration and system

Item	Equipment	Brand Name	Model No.	FCC ID	Data Cable	Power Cord
1.	System Simulator	Anritsu	MT8000A	N/A	N/A	Unshielded, 1.8 m
2.	iPod Earphone	Apple	N/A	Verification	Unshielded, 1.0 m	N/A

2.4 Frequency List of Low/Middle/High Channels

5G NR Band n77 Channel and Frequency List				
BW [MHz]	Channel/Frequency(MHz)	Lowest	Middle	Highest
100	Channel	650000	656000	662000
	Frequency	3750	3840	3930

3 Conducted Test Items

3.1 Measuring Instruments

See list of measuring instruments of this test report.

3.1.1 Test Setup

3.1.2 Conducted Output Power

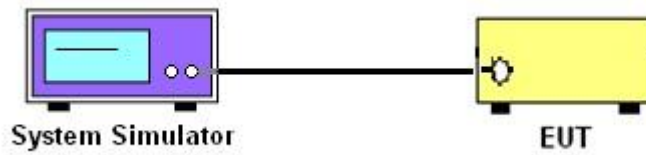

3.1.3 Test Result of Conducted Test

Please refer to Appendix A.



3.2 Conducted Output Power and EIRP

3.2.1 Description of the Conducted Output Power Measurement and EIRP Measurement

A system simulator was used to establish communication with the EUT. Its parameters were set to force the EUT transmitting at maximum output power. The measured power in the radio frequency on the transmitter output terminals shall be reported.

The EIRP of mobile transmitters must not exceed 1 Watts for 5G NR n77.

According to KDB 412172 D01 Power Approach,

$EIRP = P_T + G_T - L_C$, $ERP = EIRP - 2.15$, where

P_T = transmitter output power in dBm

G_T = gain of the transmitting antenna in dBi

L_C = signal attenuation in the connecting cable between the transmitter and antenna in dB

3.2.2 Test Procedures

1. The transmitter output port was connected to the system simulator.
2. Set EUT at maximum power through the system simulator.
3. Select lowest, middle, and highest channels for each band and different modulation.
4. Measure and record the power level from the system simulator.

4 Radiated Test Items

4.1 Measuring Instruments

See list of measuring instruments of this test report.

4.1.1 Test Setup

For radiated emissions below 30MHz

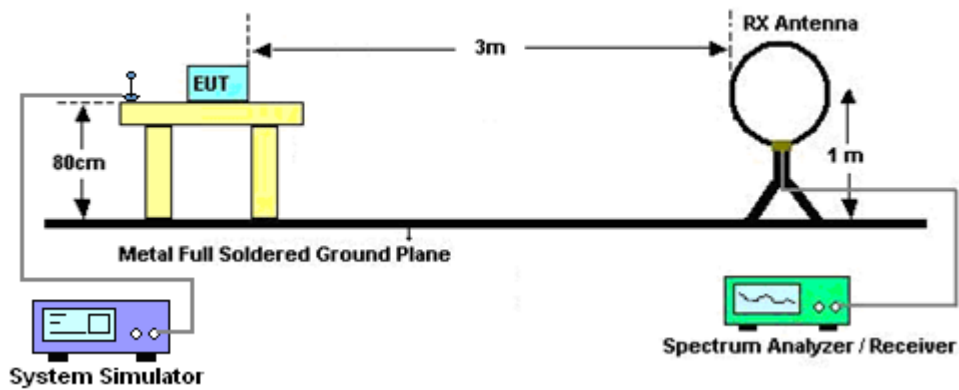

For radiated test from 30MHz to 1GHz



For radiated test from 1GHz to 18GHz

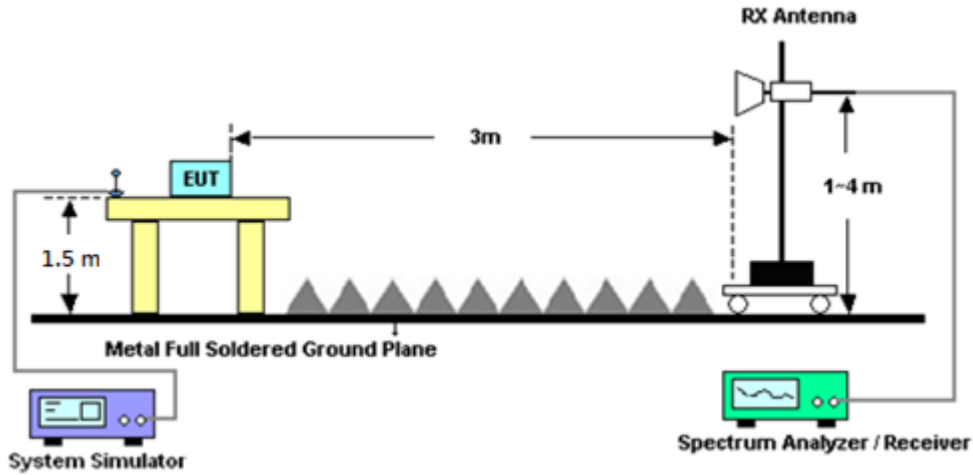

For radiated test above 18GHz

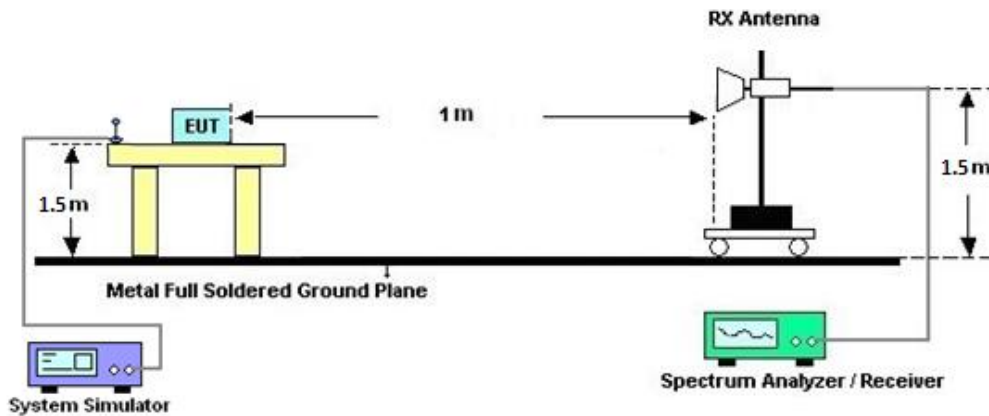

4.1.2 Test Result of Radiated Test

Please refer to Appendix B.

Note:

The low frequency, which started from 9 kHz to 30MHz, was pre-scanned and the result which was 20dB lower than the limit line was not reported.

There is adequate comparison measurement of both open-field test site and alternative test site - semi-Anechoic chamber according to 414788 D01 Radiated Test Site v01r01, and the result came out very similar.



4.2 Radiated Spurious Emission Measurement

4.2.1 Description of Radiated Spurious Emission Measurement

The radiated spurious emission was measured by substitution method according to ANSI / TIA-603-E. The power of any emission outside of the authorized operating frequency ranges must be attenuated below the transmitter power (P) by a factor of at least $43 + 10 \log (P)$ dB.

4.2.2 Test Procedures

The testing follows FCC KDB 971168 D01 v03r01 Section 7 and ANSI / TIA-603-E Section 2.2.12.

1. The EUT was placed on a turntable with 0.8 meter for frequency below 1GHz and 1.5 meter for frequency above 1GHz respectively above ground.
2. The EUT was set 3 meters from the receiving antenna, which was mounted on the antenna tower.
3. The table was rotated 360 degrees to determine the position of the highest spurious emission.
4. The height of the receiving antenna is varied between one meter and four meters to search the maximum spurious emission for both horizontal and vertical polarizations.
5. Make the measurement with the spectrum analyzer's RBW = 1MHz, VBW = 3MHz, taking the record of maximum spurious emission.
6. A horn antenna was substituted in place of the EUT and was driven by a signal generator.
7. Tune the output power of signal generator to the same emission level with EUT maximum spurious emission.
8. Taking the record of output power at antenna port.
9. Repeat step 7 to step 8 for another polarization.
10. The RF fundamental frequency should be excluded against the limit line in the operating frequency band.



5 List of Measuring Equipment

Instrument	Brand Name	Model No.	Serial No.	Characteristics	Calibration Date	Test Date	Due Date	Remark
Loop Antenna	Rohde & Schwarz	HFH2-Z2	100315	9 kHz~30 MHz	Jan. 07, 2022	Jan. 13, 2022~ Jan. 29, 2022	Jan. 06, 2023	Radiation (03CH12-HY)
Bilog Antenna	TESEQ	CBL 6111D & 00800N1D01N -06	37059 & 01	30MHz~1GHz	Oct. 09, 2021	Jan. 13, 2022~ Jan. 29, 2022	Oct. 08, 2022	Radiation (03CH12-HY)
Bilog Antenna	TESEQ	CBL 6111D & N-6-06	35414 & AT-N0602	30MHz~1GHz	Oct. 09, 2021	Jan. 13, 2022~ Jan. 29, 2022	Oct. 08, 2022	Radiation (03CH12-HY)
Horn Antenna	SCHWARZBECK	BBHA 9120 D	9120D-1326	1GHz~18GHz	Oct. 25, 2021	Jan. 13, 2022~ Jan. 29, 2022	Oct. 24, 2022	Radiation (03CH12-HY)
Horn Antenna	SCHWARZBECK	BBHA 9120 D	9120D-1212	1GHz~18GHz	May 18, 2021	Jan. 13, 2022~ Jan. 29, 2022	May 17, 2022	Radiation (03CH12-HY)
SHF-EHF Horn Antenna	SCHWARZBECK	BBHA 9170	BBHA9170251	18GHz~40GHz	Nov. 30, 2021	Jan. 13, 2022~ Jan. 29, 2022	Nov. 29, 2022	Radiation (03CH12-HY)
SHF-EHF Horn Antenna	SCHWARZBECK	BBHA 9170	BBHA9170576	18GHz~40GHz	May 21, 2021	Jan. 13, 2022~ Jan. 29, 2022	May 20, 2022	Radiation (03CH12-HY)
Preamplifier	COM-POWER	PA-103	161075	10MHz~1GHz	Mar. 24, 2021	Jan. 13, 2022~ Jan. 29, 2022	Mar. 23, 2022	Radiation (03CH12-HY)
Preamplifier	Aglient	8449B	3008A02375	1GHz~26.5GHz	May 25, 2021	Jan. 13, 2022~ Jan. 29, 2022	May 24, 2022	Radiation (03CH12-HY)
Preamplifier	E-INSTRUMENT TECH LTD.	ERA-100M-18 G-56-01-A70	EC1900249	1GHz~18GHz	Dec. 22, 2021	Jan. 13, 2022~ Jan. 29, 2022	Dec. 21, 2022	Radiation (03CH12-HY)
Preamplifier	EMEC	EM18G40G	060801	18GHz~40GHz	Jun. 22, 2021	Jan. 13, 2022~ Jan. 29, 2022	Jun. 21, 2022	Radiation (03CH12-HY)
Spectrum Analyzer	Agilent	N9010B	MY60240520	10Hz~44GHz	Dec. 23, 2021	Jan. 13, 2022~ Jan. 29, 2022	Dec. 22, 2022	Radiation (03CH12-HY)
RF Cable	HUBER + SUHNER	SUCOFLEX 104	MY9837/4PE	9kHz~30MHz	Mar. 11, 2021	Jan. 13, 2022~ Jan. 29, 2022	Mar. 10, 2022	Radiation (03CH12-HY)
RF Cable	HUBER + SUHNER	SUCOFLEX 102	505134/2	30MHz~40GHz	Feb. 22, 2021	Jan. 13, 2022~ Jan. 29, 2022	Feb. 21, 2022	Radiation (03CH12-HY)
RF Cable	HUBER + SUHNER	SUCOFLEX 102	800740/2	30MHz~40GHz	Feb. 22, 2021	Jan. 13, 2022~ Jan. 29, 2022	Feb. 21, 2022	Radiation (03CH12-HY)
Filter	Wainwright	WLKS1200-12 SS	SN2	1.2GHz Low Pass Filter	Mar. 17, 2021	Jan. 13, 2022~ Jan. 29, 2022	Mar. 16, 2022	Radiation (03CH12-HY)
Filter	Wainwright	WHKX12-1080 -1200-15000-6 0SS	SN1	1.2GHz High Pass Filter	Mar. 17, 2021	Jan. 13, 2022~ Jan. 29, 2022	Mar. 16, 2022	Radiation (03CH12-HY)
Filter	Wainwright	WHKX12-2700 -3000-18000-6 0ST	SN2	3GHz High Pass Filter	Jul. 12, 2021	Jan. 13, 2022~ Jan. 29, 2022	Jul. 11, 2022	Radiation (03CH12-HY)
Filter	Wainwright	WHKX8-5872. 5-6750-18000- 40ST	SN2	6.75GHz High Pass Filter	Mar. 17, 2021	Jan. 13, 2022~ Jan. 29, 2022	Mar. 16, 2022	Radiation (03CH12-HY)
Hygrometer	TECPEL	DTM-303B	TP140349	N/A	Sep. 30, 2021	Jan. 13, 2022~ Jan. 29, 2022	Sep. 29, 2022	Radiation (03CH12-HY)
Controller	EMEC	EM1000	N/A	Control Turn table & Ant Mast	N/A	Jan. 13, 2022~ Jan. 29, 2022	N/A	Radiation (03CH12-HY)
Antenna Mast	EMEC	AM-BS-4500-B	N/A	1m~4m	N/A	Jan. 13, 2022~ Jan. 29, 2022	N/A	Radiation (03CH12-HY)
Turn Table	EMEC	TT2000	N/A	0~360 Degree	N/A	Jan. 13, 2022~ Jan. 29, 2022	N/A	Radiation (03CH12-HY)
Software	Audix	E3 6.2009-8-24	RK-000989	N/A	N/A	Jan. 13, 2022~ Jan. 29, 2022	N/A	Radiation (03CH12-HY)
Hygrometer	Testo	608-H11	3489324	NA	Jan. 18, 2021	Dec. 21, 2021~ Dec. 23, 2021	Jan. 17, 2022	Conducted (TH03-HY)
Base Station (Measure)	Anritsu	MT8821C	6262044657	LTE	Jan. 07, 2021	Dec. 21, 2021~ Dec. 23, 2021	Jan. 06, 2022	Conducted (TH03-HY)
Base Station (Measure)	Anritsu	MT8000A	6262012917	FR1	Jan. 07, 2021	Dec. 21, 2021~ Dec. 23, 2021	Jan. 06, 2022	Conducted (TH03-HY)



6 Uncertainty of Evaluation

Uncertainty of Radiated Emission Measurement (30 MHz ~ 1000 MHz)

Measuring Uncertainty for a Level of Confidence of 95% ($U = 2Uc(y)$)	3.10 dB
---	---------

Uncertainty of Radiated Emission Measurement (1 GHz ~ 18 GHz)

Measuring Uncertainty for a Level of Confidence of 95% ($U = 2Uc(y)$)	3.39 dB
---	---------

Uncertainty of Radiated Emission Measurement (18 GHz ~ 40 GHz)

Measuring Uncertainty for a Level of Confidence of 95% ($U = 2Uc(y)$)	4.34 dB
---	---------



Appendix A. Test Results of Conducted Test

Conducted Output Power(Average power) and EIRP

NR n77 Maximum Average Power [dBm] (GT - LC = 0.38 dB)								
BW [MHz]	RB Size	RB Offset	Mod	Lowest	Middle	Highest	EIRP (dBm)	EIRP(W)
100	1	1	PI/2 BPSK	25.61	25.79	25.68	26.56	0.4529
100	1	271		26.18	25.75	25.91		
100	135	67		25.90	25.79	25.88		
100	1	0		22.16	22.27	22.17		
100	1	272		22.68	22.29	22.48		
100	270	0		25.37	25.32	25.35		
100	1	1	QPSK	25.61	25.79	25.61	25.06	0.3206
100	1	271		26.11	25.77	25.91		
100	135	67		25.87	25.81	25.95		
100	1	0		22.08	22.32	22.19		
100	1	272		22.61	22.31	22.42		
100	270	0		24.87	24.83	24.87		
100	1	1	16-QAM	24.40	24.68	24.44	25.06	0.3206
100	1	1	64-QAM	23.34	23.28	23.36		
100	1	1	256-QAM	21.19	21.25	21.19		
Limit	EIRP < 1W			Result			Pass	



NR n77 (HPUE) Maximum Average Power [dBm] (GT - LC = 0.38 dB)								
BW [MHz]	RB Size	RB Offset	Mod	Lowest	Middle	Highest	EIRP (dBm)	EIRP(W)
100	1	1	PI/2 BPSK	22.65	22.78	22.63	23.56	0.2270
100	1	271		23.15	22.73	22.94		
100	135	67		22.93	22.86	22.81		
100	1	0		22.12	22.20	22.16		
100	1	272		22.59	22.30	22.40		
100	270	0		22.87	22.82	22.79		
100	1	1	QPSK	22.61	22.74	22.58		
100	1	271		23.18	22.77	22.85		
100	135	67		22.93	22.88	22.87		
100	1	0		22.11	22.25	22.06		
100	1	272		22.70	22.27	22.36		
100	270	0		22.85	22.75	22.78		
100	1	1	16-QAM	22.48	22.48	22.31	23.28	0.2128
100	1	1	64-QAM	22.72	22.90	22.70		
100	1	1	256-QAM	21.17	21.24	21.21		
Limit	EIRP < 1W			Result			Pass	



Appendix B. Test Results of Radiated Test

5G NR n77

5G NR n77 / 100MHz / PI/2 BPSK									
Channel	Frequency (MHz)	EIRP (dBm)	Limit (dBm)	Over Limit (dB)	SPA Reading (dBm)	S.G. Power (dBm)	TX Cable loss (dB)	TX Antenna Gain (dBi)	Polarization (H/V)
Lowest	7406	-44.40	-13	-31.40	-71.75	-51.56	1.94	11.25	H
	11102	-40.57	-13	-27.57	-72.25	-46.84	2.61	11.02	H
	14802	-33.29	-13	-20.29	-71.14	-40.17	2.93	11.97	H
	18505	-55.77	-13	-42.77	-74.35	-69.62	1.90	17.90	H
	22206	-53.34	-13	-40.34	-76.05	-67.96	2.05	18.82	H
	25907	-51.43	-13	-38.43	-77.79	-66.40	1.96	19.08	H
									H
	7406	-44.39	-13	-31.39	-71.59	-51.55	1.94	11.25	V
	11102	-40.13	-13	-27.13	-71.64	-46.40	2.61	11.02	V
	14802	-35.25	-13	-22.25	-71.18	-42.13	2.93	11.97	V
	18505	-56.39	-13	-43.39	-74.11	-70.24	1.90	17.90	V
	22206	-53.45	-13	-40.45	-76.18	-68.07	2.05	18.82	V
	25907	-49.85	-13	-36.85	-77.32	-64.82	1.96	19.08	V
									V



Middle	7579	-45.44	-13	-32.44	-71.95	-52.40	2.00	11.12	H
	11375	-40.40	-13	-27.40	-72.45	-47.11	2.49	11.35	H
	15162	-32.62	-13	-19.62	-70.84	-41.13	3.04	13.70	H
	18954	-55.52	-13	-42.52	-74.74	-69.52	1.75	17.90	H
	22747	-52.56	-13	-39.56	-76.73	-66.89	1.97	18.45	H
	26535	-49.92	-13	-36.92	-77.32	-64.20	2.37	18.79	H
									H
	7579	-45.10	-13	-32.10	-71.56	-52.06	2.00	11.12	V
	11375	-39.86	-13	-26.86	-71.75	-46.57	2.49	11.35	V
	15162	-34.90	-13	-21.90	-71.11	-43.41	3.04	13.70	V
	18954	-56.03	-13	-43.03	-74.54	-70.03	1.75	17.90	V
	22747	-52.51	-13	-39.51	-76.72	-66.84	1.97	18.45	V
	26535	-48.63	-13	-35.63	-77.53	-62.91	2.37	18.79	V
									V
Highest	7763	-45.38	-13	-32.38	-71.84	-52.36	2.03	11.15	H
	11643	-39.07	-13	-26.07	-71.5	-46.33	2.49	11.90	H
	15522	-33.30	-13	-20.30	-70.79	-44.09	3.14	16.07	H
	19409	-55.75	-13	-42.75	-75.04	-69.95	1.96	18.31	H
	23287	-51.82	-13	-38.82	-76.67	-65.78	1.97	18.09	H
	27168	-50.77	-13	-37.77	-77.42	-65.39	2.10	18.87	H
									H
	7763	-45.06	-13	-32.06	-71.26	-52.04	2.03	11.15	V
	11643	-39.24	-13	-26.24	-71.75	-46.50	2.49	11.90	V
	15522	-33.94	-13	-20.94	-70.72	-44.73	3.14	16.07	V
	19409	-56.09	-13	-43.09	-74.71	-70.29	1.96	18.31	V
	23287	-51.79	-13	-38.79	-76.77	-65.75	1.97	18.09	V
	27168	-49.45	-13	-36.45	-77.51	-64.07	2.10	18.87	V
									V

Remark: Spurious emissions within 30-1000MHz were found more than 20dB below limit line.