



# FCC RADIO TEST REPORT

**FCC ID** : UZ7-RTL10C1  
**Equipment** : Tablet PC with Windows OS  
**Brand Name** : Zebra  
**Model Name** : RTL10C1  
**Applicant** : Zebra Technologies Corporation  
1 Zebra Plaza, Holtsville, NY 11742  
**Manufacturer** : Zebra Technologies Corporation  
1 Zebra Plaza, Holtsville, NY 11742  
**Standard** : FCC 47 CFR Part 2, and 90(S)

The product was received on Dec. 09, 2021 and testing was performed from Dec. 24, 2021 to Feb. 16, 2022. We, Sporton International Inc. EMC & Wireless Communications Laboratory, would like to declare that the tested sample has been evaluated in accordance with the test procedures given in ANSI / TIA-603-E and has been in compliance with the applicable technical standards.

The test results in this partial report apply exclusively to the tested model / sample. Without written approval of Sporton International Inc. EMC & Wireless Communications Laboratory, the test report shall not be reproduced except in full.

*Louis Wu*

Approved by: Louis Wu

**Sporton International Inc. EMC & Wireless Communications Laboratory**  
No. 52, Huaya 1st Rd., Guishan Dist., Taoyuan City 333, Taiwan (R.O.C.)



## Table of Contents

History of this test report.....	3
Summary of Test Result.....	4
<b>1 General Description .....</b>	<b>5</b>
1.1 Feature of Equipment Under Test.....	5
1.2 Product Specification of Equipment Under Test .....	6
1.3 Modification of EUT .....	6
1.4 Maximum ERP Power .....	6
1.5 Testing Site.....	7
1.6 Applied Standards .....	7
<b>2 Test Configuration of Equipment Under Test .....</b>	<b>8</b>
2.1 Test Mode.....	8
2.2 Connection Diagram of Test System .....	8
2.3 Support Unit used in test configuration and system.....	9
2.4 Frequency List of Low/Middle/High Channels.....	9
<b>3 Conducted Test Items.....</b>	<b>10</b>
3.1 Measuring Instruments.....	10
3.2 Conducted Output Power Measurement and ERP Measurement .....	11
3.3 Field Strength of Spurious Radiation Measurement .....	12
<b>4 List of Measuring Equipment.....</b>	<b>15</b>
<b>5 Uncertainty of Evaluation.....</b>	<b>16</b>
<b>Appendix A. Test Results of Conducted Test</b>	
<b>Appendix B. Test Results of Radiated Test</b>	
<b>Appendix C. Test Setup Photographs</b>	





### Summary of Test Result

Report Clause	Ref Std. Clause	Test Items	Result (PASS/FAIL)	Remark
3.2	§2.1046 §90.635	Conducted Output Power and Effective Radiated Power	Pass	-
-	-	Peak-to-Average Ratio	-	See Note
-	§2.1049 §90.209	Occupied Bandwidth and 26dB Bandwidth	-	See Note
-	§2.1051 §90.691	Emission masks – In-band emissions	-	See Note
-	§2.1051 §90.691	Emission masks – Out of band emissions	-	See Note
-	§2.1055 §90.213	Frequency Stability for Temperature & Voltage	-	See Note
3.3	§2.1053 §90.691	Field Strength of Spurious Radiation	Pass	Under limit 36.66 dB at 2448.000 MHz

**Remark:** The module (Model: RM505Q-AE) makes no difference after verifying output power, this report reuses test data from the module report.

Declaration of Conformity:
1. The test results (PASS/FAIL) with all measurement uncertainty excluded are presented in accordance with the regulation limits or requirements declared by manufacturers. It's means measurement values may risk exceeding the limit of regulation standards, if measurement uncertainty is include in test results.
2. The measurement uncertainty please refer to this report "Uncertainty of Evaluation".
Comments and Explanations:
The product specifications of the EUT presented in the report are declared by the manufacturer who shall take full responsibility for the authenticity.

**Reviewed by: Wei Chen**  
**Report Producer: Vivian Hsu**



# 1 General Description

## 1.1 Feature of Equipment Under Test

Product Feature	
Equipment	Tablet PC with Windows OS
Brand Name	Zebra
Model Name	RTL10C1
FCC ID	UZ7-RTL10C1
Sample 1	XPAD
Sample 2	XSLATE
EUT supports Radios application	WCDMA/HSPA/LTE/5G NR/NFC/GNSS WLAN 11a/b/g/n HT20/HT40 WLAN 11ac VHT20/VHT40/VHT80/VHT160 WLAN 11ax HE20/HE40/HE80/HE160 Bluetooth BR/EDR/LE
HW Version	EV
SW Version	Windows 10 Pro
MFD	18OCT21
EUT Stage	Identical Prototype

Remark: The above EUT's information was declared by manufacturer.

Specification of Accessories				
Adaptor with CLA cable	Brand Name	Zebra	Model Number	ADP-65JH HB
Battery	Brand Name	ZEBRA	Model Number	XLBM1
Power cord	Brand Name	Zebra	Model Number	450040

Supported Unit Used in Test Configuration and System				
Keyboard	Brand Name	Zebra	Model Number	L10-KB
98 Whr Extended Battery (Certified)	Brand Name	Zebra	Model Number	XLBE1
AEI LONG RANGE RFID MODULE	Brand Name	Zebra	Model Number	M6E-MICRO
PASSIVE SHORT STYLUS	Brand Name	Zebra	Model Number	440007
ET8X MPP 2.0 ACTIVE STYLUS WITH 5 REPLACEMENT TIPS. AAAA BATTERY INCLUDED	Brand Name	Zebra	Model Number	SG-ET8X-STYLUS1-01

## 1.2 Product Specification of Equipment Under Test

Product Specification is subject to this standard	
<b>Tx Frequency</b>	814.7 ~ 823.3 MHz
<b>Rx Frequency</b>	859.7 ~ 868.3 MHz
<b>Bandwidth</b>	1.4MHz/3MHz/5MHz/10MHz/15MHz
<b>Maximum Output Power to Antenna</b>	23.27 dBm
<b>Antenna Type</b>	Fixed Internal Antenna
<b>Antenna Gain</b>	<Main>: 1.65 dBi
<b>Type of Modulation</b>	QPSK/16QAM/64QAM/256QAM

**Remark:** The above EUT's information was declared by manufacturer. Please refer to Comments and Explanations in report summary.

## 1.3 Modification of EUT

No modifications are made to the EUT during all test items.

## 1.4 Maximum ERP Power

LTE Band 26		QPSK	16QAM	64QAM	256QAM
BW (MHz)	Frequency Range (MHz)	Maximum ERP (W)	Maximum ERP (W)	Maximum ERP (W)	Maximum ERP (W)
1.4	814.7~823.3	0.1892	0.1545	0.1189	0.0624
3	815.5~822.5	0.1879	0.1521	0.1183	0.0612
5	816.5~821.5	0.1875	0.1486	0.1202	0.0608
10	819.0	0.1807	0.1514	0.1172	0.0615
15	821.5	0.1837	0.1496	0.1164	0.0615



### 1.5 Testing Site

<b>Test Site</b>	Sporton International Inc. EMC & Wireless Communications Laboratory
<b>Test Site Location</b>	No.52, Huaya 1st Rd., Guishan Dist., Taoyuan City 333, Taiwan (R.O.C.) TEL: +886-3-327-3456 FAX: +886-3-328-4978
<b>Test Site No.</b>	<b>Sporton Site No.</b> TH03-HY
<b>Test Engineer</b>	George Chen
<b>Temperature</b>	21.8~24.5°C
<b>Relative Humidity</b>	52.4~58.6%

<b>Test Site</b>	Sporton International Inc. Wensan Laboratory
<b>Test Site Location</b>	No.58, Aly. 75, Ln. 564, Wenhua 3rd, Rd., Guishan Dist., Taoyuan City 333010, Taiwan (R.O.C.) TEL: +886-3-327-0868 FAX: +886-3-327-0855
<b>Test Site No.</b>	<b>Sporton Site No.</b> 03CH12-HY (TAF Code: 3786)
<b>Test Engineer</b>	Jack Cheng, Lance Chiang and Chuan Chu
<b>Temperature</b>	22.3~26.4°C
<b>Relative Humidity</b>	58.0~66.0%
<b>Remark</b>	The Radiated Spurious Emission test item subcontracted to Sporton International Inc. Wensan Laboratory

**Note:** The test site complies with ANSI C63.4 2014 requirement.

FCC Designation No.: TW1190 and TW3786

### 1.6 Applied Standards

According to the specifications of the manufacturer, the EUT must comply with the requirements of the following standards:

- ♦ FCC 47 CFR Part 2, 90
- ♦ ANSI / TIA-603-E
- ♦ ANSI C63.26-2015
- ♦ FCC KDB 971168 D01 Power Meas. License Digital Systems v03r01
- ♦ FCC KDB 412172 D01 Determining ERP and EIRP v01r01
- ♦ FCC KDB 414788 D01 Radiated Test Site v01r01
- ♦ Interim Guidance for Equipment Authorization of Devices with Channel Bandwidths Combined Across Two Contiguous Service Rule Allocations OET/Lab/EACB, June 6, 2013

**Remark:**

1. All test items were verified and recorded according to the standards and without any deviation during the test.
2. This EUT has also been tested and complied with the requirements of FCC Part 15, Subpart B, recorded in a separate test report.
3. The TAF code is not including all the FCC KDB listed without accreditation.

## 2 Test Configuration of Equipment Under Test

### 2.1 Test Mode

During all testing, EUT is in link mode with base station emulator at maximum power level.

For radiated measurement, the measured emission level of the EUT was maximized by rotating the EUT on a turntable, adjusting the orientation of the EUT and EUT antenna in three orthogonal axis (X: flat, Y: portrait, Z: landscape), and adjusting the measurement antenna orientation, following C63.26 exploratory test procedures and find Y Plane with Accessory as worst plane.

Frequency range investigated for radiated emission is 30 MHz to 9000 MHz.

Conducted Test Cases	Band	Bandwidth (MHz)						Modulation				RB #			Test Channel			
		1.4	3	5	10	15	20	QPSK	16QAM	64QAM	256QAM	1	Half	Full	L	M	H	
Max. Output Power	26	v	v	v	v	v	-	v	v	v	v	v	v	v	v	v	v	v
E.R.P.	26	v	v	v	v	v	-	v	v	v	v	Max. Power						
Radiated Spurious Emission	26			v	v	v	-	v				v			v	v	v	
Remark	<ol style="list-style-type: none"> <li>The mark "v" means that this configuration is chosen for testing</li> <li>The mark "-" means that this bandwidth is not supported.</li> <li>LTE Band26 transmit frequency for part22 rule is 824MHz-849MHz, for part90 rule is 814MHz-824MHz. ERP over 15MHz bandwidth complies the ERP limit line of part22 rule, therefore ERP of the partial frequency spectrum which falls within part 22 also complies.</li> <li>For Radiated Test Cases, the tests were performed with Sample 1.</li> </ol>																	

### 2.2 Connection Diagram of Test System

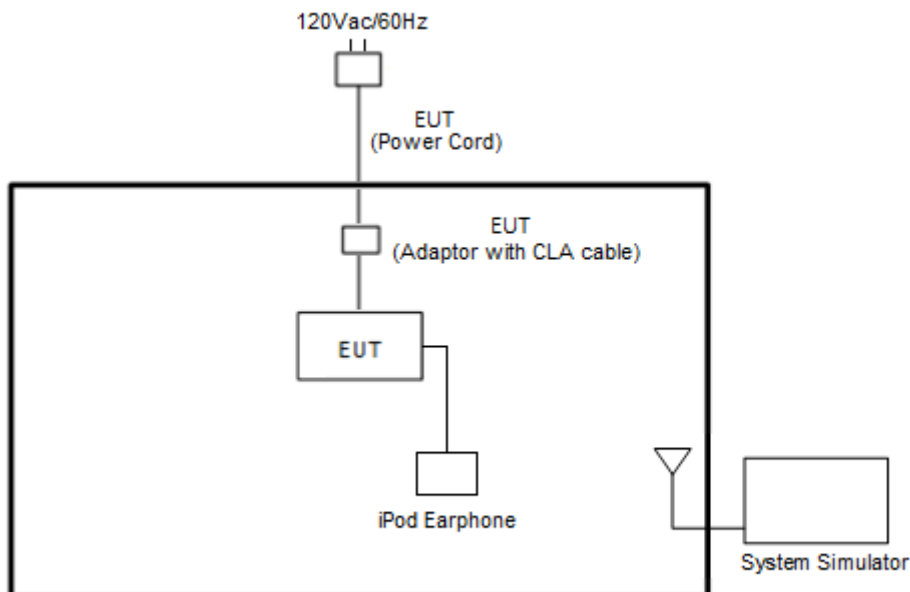





### 2.3 Support Unit used in test configuration and system

Item	Equipment	Brand Name	Model No.	FCC ID	Data Cable	Power Cord
1.	System Simulator	Anritsu	MT8821C	N/A	N/A	Unshielded, 1.8 m
2.	iPod Earphone	Apple	N/A	Verification	Unshielded, 1.0 m	N/A

### 2.4 Frequency List of Low/Middle/High Channels

LTE Band 26 Channel and Frequency List				
BW [MHz]	Channel/Frequency(MHz)	Lowest	Middle	Highest
15	Channel	26765	-	-
	Frequency	821.5	-	-
10	Channel	-	26740	-
	Frequency	-	819	-
5	Channel	26715	26740	26765
	Frequency	816.5	819	821.5
3	Channel	26705	26740	26775
	Frequency	815.5	819	822.5
1.4	Channel	26697	26740	26783
	Frequency	814.7	819	823.3

### 3 Conducted Test Items

#### 3.1 Measuring Instruments

See list of measuring instruments of this test report.

##### 3.1.1 Test Setup

##### 3.1.2 Conducted Output Power

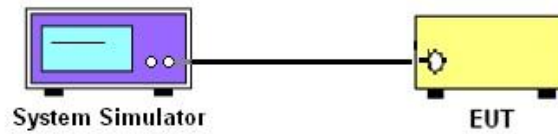

##### 3.1.3 Test Result of Conducted Test

Please refer to Appendix A.



## 3.2 Conducted Output Power Measurement and ERP Measurement

### 3.2.1 Description of the Conducted Output Power Measurement and ERP Measurement

A system simulator was used to establish communication with the EUT. Its parameters were set to enforce EUT transmitting at the maximum power. The measured power in the radio frequency on the transmitter output terminals shall be reported.

The conducted output power of mobile transmitters must not exceed 100 Watts for LTE Band 26.

According to KDB 412172 D01 Power Approach,

$EIRP = P_T + G_T - L_C$ , where

$P_T$  = transmitter output power in dBm

$G_T$  = gain of the transmitting antenna in dBi

$L_C$  = signal attenuation in the connecting cable between the transmitter and antenna in dB

### 3.2.2 Test Procedures

1. The transmitter output port was connected to the system simulator.
2. Set EUT at maximum power through system simulator.
3. Select lowest, middle, and highest channels for each band and different modulation.
4. Measure and record the power level from the system simulator.



### 3.3 Field Strength of Spurious Radiation Measurement

#### 3.3.1 Description of Field Strength of Spurious Radiated Measurement

The radiated spurious emission was measured by substitution method according to ANSI / TIA-603-E. The power of any emission FCC Part 90.691 on any frequency removed from the assigned frequency by more than 250 percent of the authorized bandwidth at least  $43 + 10 \log (P)$  dB. The spectrum is scanned from 30 MHz up to a frequency including its 10th harmonic.

The power of any emission outside of the authorized operating frequency ranges must be attenuated below the transmitter power (P) by a factor of at least  $43+10\log_{10}(P[\text{Watts}])$  dB. The spectrum is scanned from 30 MHz up to a frequency including its 10th harmonic.

#### 3.3.2 Test Procedures

1. The EUT was placed on a turntable with 0.8 meter for frequency below 1GHz and 1.5 meter for frequency above 1GHz respectively above ground.
2. The EUT was set 3 meters from the receiving antenna, which was mounted on the antenna tower.
3. The table was rotated 360 degrees to determine the position of the highest spurious emission.
4. The height of the receiving antenna is varied between one meter and four meters to search the maximum spurious emission for both horizontal and vertical polarizations.
5. For testing below 1GHz, make the measurement with the spectrum analyzer's RBW = 100 kHz, VBW = 3MHz, Sweep = 500ms, Taking the record of maximum spurious emission.
6. For testing above 1GHz, make the measurement with the spectrum analyzer's RBW = 1MHz, VBW = 3MHz, Sweep = 500ms, Taking the record of maximum spurious emission.
7. A horn antenna was substituted in place of the EUT and was driven by a signal generator.
8. Tune the output power of signal generator to the same emission level with EUT maximum spurious emission.
9. Taking the record of output power at antenna port.
10. Repeat step 7 to step 8 for another polarization.
11.  $\text{EIRP (dBm)} = \text{S.G. Power} - \text{Tx Cable Loss} + \text{Tx Antenna Gain}$
12.  $\text{ERP (dBm)} = \text{EIRP} - 2.15$
13. The RF fundamental frequency should be excluded against the limit line in the operating frequency band.
14. The limit line is derived from  $43 + 10\log(P)$  dB below the transmitter power P(Watts)

### 3.3.3 Test Setup

For radiated test below 30MHz

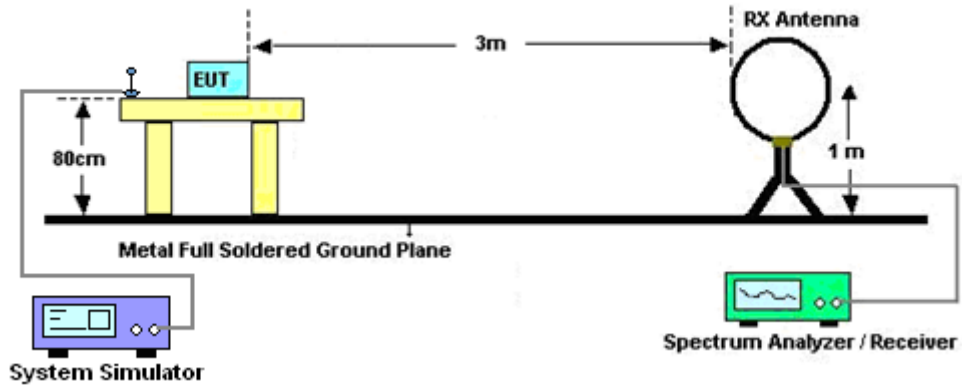

For radiated test from 30MHz to 1GHz

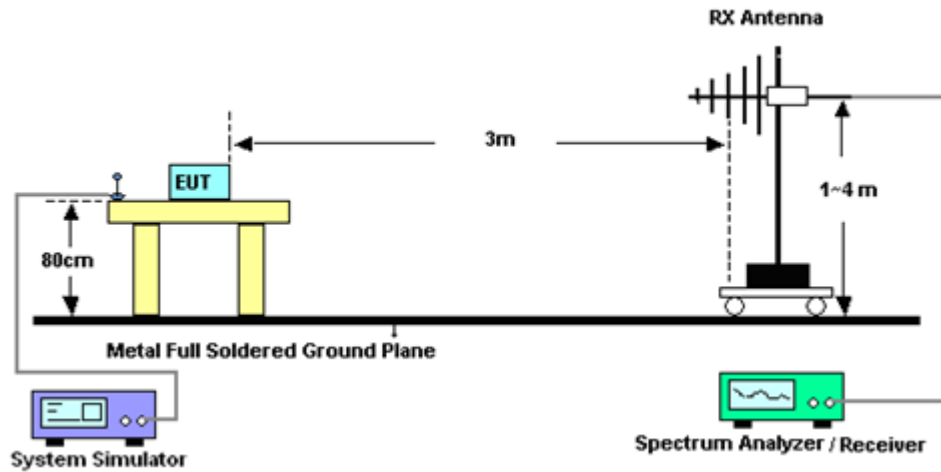

For radiated test above 1GHz

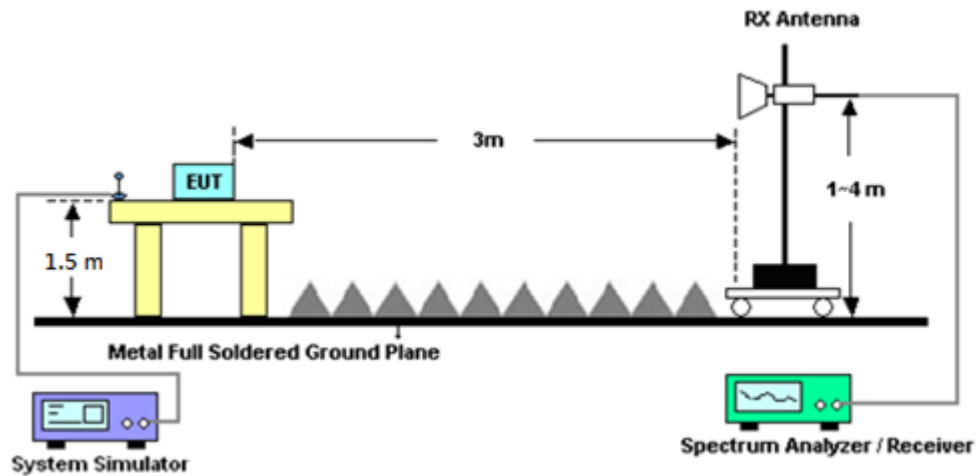

### 3.3.4 Test Result of Field Strength of Spurious Radiated

Please refer to Appendix B.

**Note:**

The low frequency, which started from 9 kHz to 30MHz, was pre-scanned and the result which was 20dB lower than the limit line was not reported.

There is adequate comparison measurement of both open-field test site and alternative test site - semi-Anechoic chamber according to 414788 D01 Radiated Test Site v01r01, and the result came out very similar.



## 4 List of Measuring Equipment

Instrument	Brand Name	Model No.	Serial No.	Characteristics	Calibration Date	Test Date	Due Date	Remark
Loop Antenna	Rohde & Schwarz	HFH2-Z2	100315	9 kHz~30 MHz	Jan. 07, 2022	Jan. 13, 2022~ Jan. 29, 2022	Jan. 06, 2023	Radiation (03CH12-HY)
Bilog Antenna	TESEQ	CBL 6111D & 00800N1D01N -06	37059 & 01	30MHz~1GHz	Oct. 09, 2021	Jan. 13, 2022~ Jan. 29, 2022	Oct. 08, 2022	Radiation (03CH12-HY)
Bilog Antenna	TESEQ	CBL 6111D & N-6-06	35414 & AT-N0602	30MHz~1GHz	Oct. 09, 2021	Jan. 13, 2022~ Jan. 29, 2022	Oct. 08, 2022	Radiation (03CH12-HY)
Horn Antenna	SCHWARZBE CK	BBHA 9120 D	9120D-1326	1GHz~18GHz	Oct. 25, 2021	Jan. 13, 2022~ Jan. 29, 2022	Oct. 24, 2022	Radiation (03CH12-HY)
Horn Antenna	SCHWARZBE CK	BBHA 9120 D	9120D-1212	1GHz~18GHz	May 18, 2021	Jan. 13, 2022~ Jan. 29, 2022	May 17, 2022	Radiation (03CH12-HY)
Preamplifier	COM-POWE R	PA-103	161075	10MHz~1GHz	Mar. 24, 2021	Jan. 13, 2022~ Jan. 29, 2022	Mar. 23, 2022	Radiation (03CH12-HY)
Preamplifier	Aglient	8449B	3008A02375	1GHz~26.5GHz	May 25, 2021	Jan. 13, 2022~ Jan. 29, 2022	May 24, 2022	Radiation (03CH12-HY)
Preamplifier	E-INSTRUME NT TECH LTD.	ERA-100M-18 G-56-01-A70	EC1900249	1GHz~18GHz	Dec. 22, 2021	Jan. 13, 2022~ Jan. 29, 2022	Dec. 21, 2022	Radiation (03CH12-HY)
Spectrum Analyzer	Agilent	N9010B	MY60240520	10Hz~44GHz	Dec. 23, 2021	Jan. 13, 2022~ Jan. 29, 2022	Dec. 22, 2022	Radiation (03CH12-HY)
RF Cable	HUBER + SUHNER	SUCOFLEX 104	MY9837/4PE	9kHz~30MHz	Mar. 11, 2021	Jan. 13, 2022~ Jan. 29, 2022	Mar. 10, 2022	Radiation (03CH12-HY)
RF Cable	HUBER + SUHNER	SUCOFLEX 102	505134/2	30MHz~40GHz	Feb. 22, 2021	Jan. 13, 2022~ Jan. 29, 2022	Feb. 21, 2022	Radiation (03CH12-HY)
RF Cable	HUBER + SUHNER	SUCOFLEX 102	800740/2	30MHz~40GHz	Feb. 22, 2021	Jan. 13, 2022~ Jan. 29, 2022	Feb. 21, 2022	Radiation (03CH12-HY)
Filter	Wainwright	WLKS1200-12 SS	SN2	1.2GHz Low Pass Filter	Mar. 17, 2021	Jan. 13, 2022~ Jan. 29, 2022	Mar. 16, 2022	Radiation (03CH12-HY)
Filter	Wainwright	WHKX12-108 0-1200-15000- 60SS	SN1	1.2GHz High Pass Filter	Mar. 17, 2021	Jan. 13, 2022~ Jan. 29, 2022	Mar. 16, 2022	Radiation (03CH12-HY)
Filter	Wainwright	WHKX12-270 0-3000-18000- 60ST	SN2	3GHz High Pass Filter	Jul. 12, 2021	Jan. 13, 2022~ Jan. 29, 2022	Jul. 11, 2022	Radiation (03CH12-HY)
Filter	Wainwright	WHKX8-5872. 5-6750-18000- 40ST	SN2	6.75GHz High Pass Filter	Mar. 17, 2021	Jan. 13, 2022~ Jan. 29, 2022	Jul. 16, 2022	Radiation (03CH12-HY)
Hygrometer	TECPEL	DTM-303B	TP140349	N/A	Sep. 30, 2021	Jan. 13, 2022~ Jan. 29, 2022	Sep. 29, 2022	Radiation (03CH12-HY)
Controller	EMEC	EM1000	N/A	Control Turn table & Ant Mast	N/A	Jan. 13, 2022~ Jan. 29, 2022	N/A	Radiation (03CH12-HY)
Antenna Mast	EMEC	AM-BS-4500- B	N/A	1m~4m	N/A	Jan. 13, 2022~ Jan. 29, 2022	N/A	Radiation (03CH12-HY)
Turn Table	EMEC	TT2000	N/A	0~360 Degree	N/A	Jan. 13, 2022~ Jan. 29, 2022	N/A	Radiation (03CH12-HY)
Software	Audix	E3 6.2009-8-24	RK-000989	N/A	N/A	Jan. 13, 2022~ Jan. 29, 2022	N/A	Radiation (03CH12-HY)
Radio Communication Analyzer	Anritsu	MT8821C	6201664755	2/3/4G/LTE FDD/TDD with44)/LTE-3C C DLCA/2CC ULCA, CatM1/NB1/NB2	Jul. 21, 2021	Dec. 24, 2021~ Feb. 16, 2022	Jul. 20, 2022	Conducted (TH03-HY)



## 5 Uncertainty of Evaluation

### Uncertainty of Radiated Emission Measurement (30 MHz ~ 1000 MHz)

Measuring Uncertainty for a Level of Confidence of 95% ( $U = 2Uc(y)$ )	3.10 dB
---	---------

### Uncertainty of Radiated Emission Measurement (1 GHz ~ 18 GHz)

Measuring Uncertainty for a Level of Confidence of 95% ( $U = 2Uc(y)$ )	3.39 dB
---	---------





## Appendix A. Test Results of Conducted Test

### Conducted Output Power(Average power & ERP)

LTE Band 26 Maximum Average Power [dBm] (GT - LC = 1.65 dB)								
BW [MHz]	RB Size	RB Offset	Mod	Lowest	Middle	Highest	ERP (dBm)	ERP (W)
15	1	0	QPSK	23.14	-	-	22.64	0.1837
15	1	37		23.05	-	-		
15	1	74		23.11	-	-		
15	36	0		22.01	-	-		
15	36	20		22.07	-	-		
15	36	39		22.12	-	-		
15	75	0		22.07	-	-		
15	1	0	16-QAM	22.25	-	-	21.75	0.1496
15	1	37		22.20	-	-		
15	1	74		22.24	-	-		
15	36	0		21.03	-	-		
15	36	20		21.07	-	-		
15	36	39		21.12	-	-		
15	75	0		21.10	-	-		
15	1	0	64-QAM	21.13	-	-	20.66	0.1164
15	1	37		21.10	-	-		
15	1	74		21.16	-	-		
15	36	0		20.06	-	-		
15	36	20		20.11	-	-		
15	36	39		20.20	-	-		
15	75	0		20.12	-	-		
15	1	0	256-QAM	18.33	-	-	17.89	0.0615
15	1	37		18.39	-	-		
15	1	74		18.27	-	-		
15	36	0		18.10	-	-		
15	36	20		18.22	-	-		
15	36	39		18.23	-	-		
15	75	0		18.33	-	-		
Limit	Power < 100W			Result			Pass	



LTE Band 26 Maximum Average Power [dBm] (GT - LC = 1.65 dB)								
BW [MHz]	RB Size	RB Offset	Mod	Lowest	Middle	Highest	ERP (dBm)	ERP (W)
10	1	0	QPSK	-	23.07	-	22.57	0.1807
10	1	25		-	23.00	-		
10	1	49		-	23.03	-		
10	25	0		-	22.02	-		
10	25	12		-	22.15	-		
10	25	25		-	22.11	-		
10	50	0		-	22.02	-		
10	1	0	16-QAM	-	22.30	-	21.8	0.1514
10	1	25		-	22.23	-		
10	1	49		-	22.14	-		
10	25	0		-	21.09	-		
10	25	12		-	21.10	-		
10	25	25		-	21.00	-		
10	50	0		-	21.00	-		
10	1	0	64-QAM	-	21.09	-	20.69	0.1172
10	1	25		-	21.19	-		
10	1	49		-	21.19	-		
10	25	0		-	20.07	-		
10	25	12		-	20.18	-		
10	25	25		-	20.02	-		
10	50	0		-	20.17	-		
10	1	0	256-QAM	-	18.29	-	17.89	0.0615
10	1	25		-	18.39	-		
10	1	49		-	18.22	-		
10	25	0		-	18.25	-		
10	25	12		-	18.19	-		
10	25	25		-	18.17	-		
10	50	0		-	18.05	-		
Limit	Power < 100W			Result			Pass	



LTE Band 26 Maximum Average Power [dBm] (GT - LC = 1.65 dB)								
BW [MHz]	RB Size	RB Offset	Mod	Lowest	Middle	Highest	ERP (dBm)	ERP (W)
5	1	0	QPSK	23.06	23.12	23.09	22.73	0.1875
5	1	12		23.13	23.23	23.16		
5	1	24		23.10	23.17	23.15		
5	12	0		22.14	22.13	22.09		
5	12	7		22.02	22.11	21.94		
5	12	13		22.07	22.09	22.13		
5	25	0		22.05	22.04	22.03		
5	1	0	16-QAM	22.13	22.14	22.12	21.72	0.1486
5	1	12		22.14	22.17	22.22		
5	1	24		22.21	22.15	22.13		
5	12	0		21.03	20.96	21.01		
5	12	7		21.03	21.10	21.04		
5	12	13		21.01	21.05	20.94		
5	25	0		21.26	21.21	21.17		
5	1	0	64-QAM	21.00	20.98	20.96	20.8	0.1202
5	1	12		21.20	21.30	21.13		
5	1	24		21.29	21.20	21.21		
5	12	0		20.26	20.26	20.19		
5	12	7		20.16	20.09	20.09		
5	12	13		20.07	20.02	20.16		
5	25	0		20.08	20.04	20.16		
5	1	0	256-QAM	18.26	18.32	18.33	17.84	0.0608
5	1	12		18.28	18.34	18.32		
5	1	24		18.27	18.24	18.23		
5	12	0		18.20	18.28	18.27		
5	12	7		18.15	18.08	18.14		
5	12	13		18.16	18.12	18.12		
5	25	0		18.20	18.16	18.26		
Limit	Power < 100W			Result			Pass	



LTE Band 26 Maximum Average Power [dBm] (GT - LC = 1.65 dB)								
BW [MHz]	RB Size	RB Offset	Mod	Lowest	Middle	Highest	ERP (dBm)	ERP (W)
3	1	0	QPSK	23.00	22.99	23.08	22.74	0.1879
3	1	8		23.15	23.10	23.24		
3	1	14		23.04	23.04	23.02		
3	8	0		22.17	22.16	22.18		
3	8	4		22.25	22.30	22.35		
3	8	7		22.23	22.19	22.26		
3	15	0		22.01	22.01	22.06		
3	1	0	16-QAM	22.06	21.97	22.00	21.82	0.1521
3	1	8		22.03	22.11	21.93		
3	1	14		22.24	22.32	22.18		
3	8	0		21.14	21.12	21.24		
3	8	4		21.00	20.97	21.03		
3	8	7		21.04	21.00	21.04		
3	15	0		21.03	21.06	21.03		
3	1	0	64-QAM	21.08	21.04	21.04	20.73	0.1183
3	1	8		21.22	21.23	21.15		
3	1	14		21.11	21.15	21.01		
3	8	0		20.27	20.25	20.37		
3	8	4		20.18	20.16	20.16		
3	8	7		20.02	19.97	20.08		
3	15	0		20.14	20.24	20.07		
3	1	0	256-QAM	18.27	18.24	18.37	17.87	0.0612
3	1	8		18.21	18.24	18.29		
3	1	14		18.18	18.25	18.24		
3	8	0		18.07	18.15	17.99		
3	8	4		18.04	18.07	17.95		
3	8	7		18.08	18.00	17.98		
3	15	0		18.17	18.11	18.17		
Limit	Power < 100W			Result			Pass	



LTE Band 26 Maximum Average Power [dBm] (GT - LC = 1.65 dB)								
BW [MHz]	RB Size	RB Offset	Mod	Lowest	Middle	Highest	ERP (dBm)	ERP (W)
1.4	1	0	QPSK	23.17	23.07	23.20	22.77	0.1892
1.4	1	3		23.11	23.18	23.05		
1.4	1	5		23.13	23.10	23.12		
1.4	3	0		23.10	23.19	23.11		
1.4	3	1		23.04	22.94	23.08		
1.4	3	3		23.19	23.19	23.27		
1.4	6	0		22.12	22.04	22.06		
1.4	1	0	16-QAM	22.29	22.34	22.31	21.89	0.1545
1.4	1	3		22.29	22.39	22.35		
1.4	1	5		22.00	21.91	21.98		
1.4	3	0		22.10	22.01	22.00		
1.4	3	1		22.00	21.94	21.97		
1.4	3	3		22.13	22.15	22.17		
1.4	6	0		21.02	21.05	21.05		
1.4	1	0	64-QAM	21.13	21.10	21.21	20.75	0.1189
1.4	1	3		21.16	21.25	21.11		
1.4	1	5		21.03	21.13	20.94		
1.4	3	0		21.02	21.07	20.96		
1.4	3	1		21.16	21.10	21.07		
1.4	3	3		21.14	21.09	21.05		
1.4	6	0		20.17	20.19	20.17		
1.4	1	0	256-QAM	18.30	18.23	18.23	17.95	0.0624
1.4	1	3		18.35	18.39	18.39		
1.4	1	5		18.25	18.25	18.21		
1.4	3	0		18.22	18.23	18.25		
1.4	3	1		18.37	18.43	18.42		
1.4	3	3		18.41	18.45	18.36		
1.4	6	0		18.32	18.37	18.22		
Limit	Power < 100W			Result			Pass	



## Appendix B. Test Results of Radiated Test

### LTE Band 26

LTE Band 26 / 5MHz / QPSK									
Channel	Frequency ( MHz )	ERP ( dBm )	Limit ( dBm )	Over Limit ( dB )	SPA Reading (dBm)	S.G. Power ( dBm )	TX Cable loss ( dB )	TX Antenna Gain (dBi)	Polarization (H/V)
Lowest	1632	-57.44	-13	-44.44	-67.04	-62.98	0.91	8.60	H
	2443	-52.10	-13	-39.10	-66.03	-59.43	1.14	10.62	H
	3256	-54.69	-13	-41.69	-70.83	-63.14	1.32	11.91	H
									H
									H
									H
	1632	-54.81	-13	-41.81	-63.94	-60.35	0.91	8.60	V
	2443	-50.59	-13	-37.59	-64.59	-57.92	1.14	10.62	V
	3256	-54.88	-13	-41.88	-71.51	-63.33	1.32	11.91	V
									V
									V
									V
Middle	1632	-58.15	-13	-45.15	-67.75	-63.69	0.91	8.60	H
	2451	-51.74	-13	-38.74	-65.69	-59.08	1.14	10.63	H
	3264	-55.02	-13	-42.02	-71.15	-63.49	1.32	11.93	H
									H
									H
									H
	1632	-57.16	-13	-44.16	-66.29	-62.70	0.91	8.60	V
	2451	-50.32	-13	-37.32	-64.36	-57.66	1.14	10.63	V
	3264	-54.19	-13	-41.19	-70.8	-62.66	1.32	11.93	V
									V
									V
									V



LTE Band 26 / 5MHz / QPSK									
Channel	Frequency ( MHz )	ERP ( dBm )	Limit ( dBm )	Over Limit ( dB )	SPA Reading (dBm)	S.G. Power ( dBm )	TX Cable loss ( dB )	TX Antenna Gain (dBi)	Polarization (H/V)
Highest	1640	-59.58	-13	-46.58	-69.21	-65.14	0.92	8.63	H
	2458	-53.26	-13	-40.26	-67.2	-60.61	1.14	10.64	H
	3280	-54.86	-13	-41.86	-70.96	-63.36	1.32	11.97	H
									H
									H
									H
	1640	-60.99	-13	-47.99	-70.11	-66.55	0.92	8.63	V
	2458	-50.34	-13	-37.34	-64.39	-57.69	1.14	10.64	V
	3280	-54.44	-13	-41.44	-71.02	-62.94	1.32	11.97	V
									V
									V
									V

Remark: Spurious emissions within 30-1000MHz were found more than 20dB below limit line.

LTE Band 26 / 10MHz / QPSK									
Channel	Frequency ( MHz )	ERP ( dBm )	Limit ( dBm )	Over Limit ( dB )	SPA Reading (dBm)	S.G. Power ( dBm )	TX Cable loss ( dB )	TX Antenna Gain (dBi)	Polarization (H/V)
Middle	1632	-57.61	-13	-44.61	-67.21	-63.15	0.91	8.60	H
	2443	-52.19	-13	-39.19	-66.12	-59.52	1.14	10.62	H
	3256	-54.98	-13	-41.98	-71.12	-63.43	1.32	11.91	H
									H
									H
									H
	1632	-55.35	-13	-42.35	-64.48	-60.89	0.91	8.60	V
	2443	-51.30	-13	-38.30	-65.3	-58.63	1.14	10.62	V
	3256	-54.61	-13	-41.61	-71.24	-63.06	1.32	11.91	V
									V
									V
									V

Remark: Spurious emissions within 30-1000MHz were found more than 20dB below limit line.



LTE Band 26 / 15MHz / QPSK									
Channel	Frequency ( MHz )	ERP ( dBm )	Limit ( dBm )	Over Limit ( dB )	SPA Reading (dBm)	S.G. Power ( dBm )	TX Cable loss ( dB )	TX Antenna Gain (dBi)	Polarization (H/V)
Lowest	1632	-56.36	-13	-43.36	-65.96	-61.90	0.91	8.60	H
	2448	-52.60	-13	-39.60	-66.54	-59.94	1.14	10.63	H
	3256	-54.89	-13	-41.89	-71.03	-63.34	1.32	11.91	H
									H
									H
									H
									H
	1632	-55.41	-13	-42.41	-64.54	-60.95	0.91	8.60	V
	2448	-49.66	-13	-36.66	-63.69	-57.00	1.14	10.63	V
	3256	-54.69	-13	-41.69	-71.32	-63.14	1.32	11.91	V
									V
									V
									V
									V

Remark: Spurious emissions within 30-1000MHz were found more than 20dB below limit line.