



# FCC TEST REPORT

**REPORT NO.:** RF970416H07

**MODEL NO.:** CTR500

**RECEIVED:** April 17, 2008

**TESTED:** May 15 to June 02, 2008

**ISSUED:** June 04, 2008

**APPLICANT:** Cradlepoint, Inc

**ADDRESS:** 1199 Shoreline Lane, Suite 301 Boise, ID 83702

**ISSUED BY:** Advance Data Technology Corporation

**TEST LOCATION:** No. 81-1, Lu Liao Keng, 9 Ling, Wu Lung  
Tsuen, Chiung Lin Hsiang, Hsin Chu Hsien,  
Taiwan, R.O.C.

This test report consists of 82 pages in total. It may be duplicated completely for legal use with the approval of the applicant. It should not be reproduced except in full, without the written approval of our laboratory. The client should not use it to claim product endorsement by TAF, A2LA or any government agencies. The test results in the report only apply to the tested sample.



## Table of Contents

1.	CERTIFICATION .....	4
2.	SUMMARY OF TEST RESULTS .....	5
2.1	MEASUREMENT UNCERTAINTY .....	6
3.	GENERAL INFORMATION .....	7
3.1	GENERAL DESCRIPTION OF EUT .....	7
3.2	DESCRIPTION OF TEST MODES .....	9
3.2.1	TEST MODE APPLICABILITY AND TESTED CHANNEL DETAIL: .....	10
3.3	GENERAL DESCRIPTION OF APPLIED STANDARDS .....	14
3.4	DESCRIPTION OF SUPPORT UNITS.....	15
3.5	CONFIGURATION OF SYSTEM UNDER TEST .....	15
4.	TEST TYPES AND RESULTS .....	16
4.1	CONDUCTED EMISSION MEASUREMENT .....	16
4.1.1	LIMITS OF CONDUCTED EMISSION MEASUREMENT .....	16
4.1.2	TEST INSTRUMENTS.....	16
4.1.3	TEST PROCEDURES .....	17
4.1.4	DEVIATION FROM TEST STANDARD .....	17
4.1.5	TEST SETUP .....	18
4.1.6	EUT OPERATING CONDITIONS .....	18
4.1.7	TEST RESULTS .....	19
4.2	RADIATED EMISSION MEASUREMENT .....	25
4.2.1	LIMITS OF RADIATED EMISSION MEASUREMENT .....	25
4.2.2	TEST INSTRUMENTS.....	26
4.2.3	TEST PROCEDURES .....	27
4.2.4	DEVIATION FROM TEST STANDARD .....	27
4.2.5	TEST SETUP .....	28
4.2.6	EUT OPERATING CONDITIONS .....	28
4.2.7	TEST RESULTS .....	29
	Above 1GHz Test Data.....	31
4.2.8	TEST RESULTS .....	31
4.3	6dB BANDWIDTH MEASUREMENT .....	59
4.3.1	LIMITS OF 6dB BANDWIDTH MEASUREMENT .....	59
4.3.2	TEST INSTRUMENTS.....	59
4.3.3	TEST PROCEDURE.....	59
4.3.4	DEVIATION FROM TEST STANDARD .....	59
4.3.5	TEST SETUP .....	59
4.3.6	EUT OPERATING CONDITIONS .....	59
4.3.7	TEST RESULTS .....	60
4.4	MAXIMUM PEAK OUTPUT POWER.....	64
4.4.1	LIMITS OF MAXIMUM PEAK OUTPUT POWER MEASUREMENT .....	64

4.4.2	INSTRUMENTS.....	64
4.4.3	TEST PROCEDURES .....	65
4.4.4	DEVIATION FROM TEST STANDARD .....	65
4.4.5	TEST SETUP .....	65
4.4.6	EUT OPERATING CONDITIONS .....	65
4.4.7	TEST RESULTS .....	66
4.5	POWER SPECTRAL DENSITY MEASUREMENT .....	68
4.5.1	LIMITS OF POWER SPECTRAL DENSITY MEASUREMENT .....	68
4.5.2	TEST INSTRUMENTS.....	68
4.5.3	TEST PROCEDURE.....	69
4.5.4	DEVIATION FROM TEST STANDARD .....	69
4.5.5	TEST SETUP .....	69
4.5.6	EUT OPERATING CONDITION .....	69
4.5.7	TEST RESULTS .....	70
4.6	BAND EDGES MEASUREMENT.....	74
4.6.1	LIMITS OF BAND EDGES MEASUREMENT .....	74
4.6.2	TEST INSTRUMENTS.....	74
4.6.3	TEST PROCEDURE.....	74
4.6.4	DEVIATION FROM TEST STANDARD .....	75
4.6.5	EUT OPERATING CONDITION .....	75
4.6.6	TEST RESULTS .....	75
4.7	ANTENNA REQUIREMENT .....	80
4.7.1	STANDARD APPLICABLE.....	80
4.7.2	ANTENNA CONNECTED CONSTRUCTION.....	80
5.	INFORMATION ON THE TESTING LABORATORIES .....	81
6.	APPENDIX A - MODIFICATIONS RECORDERS FOR ENGINEERING CHANGES TO THE EUT BY THE LAB .....	82



## 1. CERTIFICATION

**PRODUCT:** CTR500  
**BRAND NAME:** Cradlepoint  
**MODEL NO.:** CTR500  
**TESTED:** May 15 to June 02, 2008  
**TEST SAMPLE:** PROTOTYPE  
**APPLICANT:** Cradlepoint, Inc  
**STANDARDS:** FCC Part 15, Subpart C (Section 15.247),  
ANSI C63.4-2003

The above equipment (Model: CTR500) has been tested by **Advance Data Technology Corporation**, and found compliance with the requirement of the above standards. The test record, data evaluation & Equipment Under Test (EUT) configurations represented herein are true and accurate accounts of the measurements of the sample's EMC characteristics under the conditions specified in this report.

**PREPARED BY :** Sunny Wen , **DATE:** June 04, 2008  
( Sunny Wen, Specialist )

**TECHNICAL ACCEPTANCE :** Hank Chung , **DATE:** June 04, 2008  
Responsible for RF ( Hank Chung, Deputy Manager )

**APPROVED BY :** May Chen , **DATE:** June 04, 2008  
( May Chen, Deputy Manager )

## 2. SUMMARY OF TEST RESULTS

The EUT has been tested according to the following specifications:

<b>APPLIED STANDARD: FCC Part 15, Subpart C (Section 15.247)</b>			
<b>Standard Section</b>	<b>Test Type and Limit</b>	<b>Result</b>	<b>Remark</b>
15.207	AC Power Conducted Emission	PASS	Meet the requirement of limit. Minimum passing margin is -11.61dB at 0.181MHz
15.247(a)(2)	Spectrum Bandwidth of a Direct Sequence Spread Spectrum System Limit: min. 500kHz	PASS	Meet the requirement of limit.
15.247(b)	Maximum Peak Output Power Limit: max. 30dBm	PASS	Meet the requirement of limit.
15.247(d)	Radiated Emissions Limit: Table 15.209	PASS	Meet the requirement of limit. Minimum passing margin is -0.50 dB at 4824.00 MHz
15.247(e)	Power Spectral Density Limit: max. 8dBm	PASS	Meet the requirement of limit.
15.247(d)	Band Edge Measurement Limit: 20dB less than the peak value of fundamental frequency	PASS	Meet the requirement of limit.

## 2.1 MEASUREMENT UNCERTAINTY

Where relevant, the following measurement uncertainty levels have been estimated for tests performed on the EUT as specified in CISPR 16-4:

This uncertainty represents an expanded uncertainty expressed at approximately the 95% confidence level using a coverage factor of  $k=2$ .

Measurement	Value
Conducted emissions	2.44 dB
Radiated emissions (30MHz-1GHz)	3.94 dB
Radiated emissions (1GHz -18GHz)	2.33 dB
Radiated emissions (18GHz -40GHz)	2.55 dB

### 3. GENERAL INFORMATION

#### 3.1 GENERAL DESCRIPTION OF EUT

<b>PRODUCT</b>	CTR500
<b>MODEL NO.</b>	CTR500
<b>FCC ID</b>	UXX-CTR500
<b>POWER SUPPLY</b>	DC 5V from power adapter
<b>MODULATION TYPE</b>	CCK, DQPSK, DBPSK for DSSS 64QAM, 16QAM, QPSK, BPSK for OFDM
<b>MODULATION TECHNOLOGY</b>	DSSS, OFDM
<b>TRANSFER RATE</b>	802.11b: 11 / 5.5 / 2 / 1Mbps 802.11g: 54 / 48 / 36 / 24 / 18 / 12 / 9 / 6Mbps
<b>FREQUENCY RANGE</b>	2412 ~ 2462MHz
<b>NUMBER OF CHANNEL</b>	11
<b>MAXIMUM OUTPUT POWER</b>	802.11b: 53.703mW 802.11g: 60.256mW
<b>ANTENNA TYPE</b>	Please see note 1
<b>DATA CABLE</b>	NA
<b>I/O PORT</b>	Ethernet Port (10/100Mbps) x 1, USB Port for 1XEV-DO x 1, Express card for 1XEV-DO Port x 1

**NOTE:**

- There are two printed antennas provided to this EUT, and the following two dipole antennas are option:

Antenna	Antenna Type	Antenna Connector	Gain (dBi)	Function	Note
Antenna 1	Printed	NA	1	Only RX	Fixed
Antenna 2	Printed	I-PEX	1	TX / RX	
Antenna 3	Dipole	MMCX	2		TX / RX
Antenna 4	Dipole	MMCX	5		

From the above antennas, the worst cases were found in Antenna 2 & 4. Therefore only the test data of the modes were recorded in this report individually.

2. The EUT could be applied with one 3.5G 1XEV-DO Card and following two different models could be chosen; therefore emission tests are added for simultaneously transmit between wireless LAN and 3.5G 1XEV-DO function. The emission tests have been performed at the worst channel of both WLAN and 3.5G 1XEV-DO, and recorded in other report.

Interface	Brand name	Model name	FCC ID
Express card	SIERRA WIRELESS	AirCard 880E	N7NAC880E
USB port	SIERRA WIRELESS	COMPASS 597	N7NC597

From the above 3.5G 1XEV-DO cards, Model No.: AirCard 880E was selected for testing. Only one card can transmit on different interface for 1XEV-DO.

3. The EUT must be supplied with a power adapter and following three different models could be chosen:

Adapter 1	
<b>Brand:</b>	PHIHONG
<b>Model No.:</b>	PSA15R-050P
<b>Input power :</b>	AC 100-240V, 0.5A, 50/60Hz
<b>Output power :</b>	DC 5V, 3.0A Cable:1.9m/unshielded/with one core
Adapter 2	
<b>Brand:</b>	PHIHONG
<b>Model No.:</b>	PSA15R-050P
<b>Input power :</b>	AC 100-240V, 0.5A, 50/60Hz
<b>Output power :</b>	DC 5V, 3.0A Cable:1.9m/unshielded/without core
Adapter 3	
<b>Brand:</b>	Technics-gp
<b>Model No.:</b>	TESA1G-0503000
<b>Input power :</b>	AC100-240V, 50/60Hz, MAX 0.45A
<b>Output power :</b>	DC 5V, 2.5A Cable:1.8m/unshielded/without core

4. The above EUT information was declared by manufacturer and for more detailed features description, please refer to the manufacturer's specifications or user's manual.



### 3.2 DESCRIPTION OF TEST MODES

Eleven channels are provided for 802.11b, 802.11g:

CHANNEL	FREQUENCY	CHANNEL	FREQUENCY
1	2412MHz	7	2442MHz
2	2417MHz	8	2447MHz
3	2422MHz	9	2452MHz
4	2427MHz	10	2457MHz
5	2432MHz	11	2462MHz
6	2437MHz		

### 3.2.1 TEST MODE APPLICABILITY AND TESTED CHANNEL DETAIL:

EUT CONFIGURE MODE	APPLICABLE TO				DESCRIPTION
	PLC	RE < 1G	RE ≥ 1G	APCM	
-	√	√	√	√	-

Where **PLC**: Power Line Conducted Emission      **RE < 1G**: Radiated Emission below 1GHz  
**RE ≥ 1G**: Radiated Emission above 1GHz      **APCM**: Antenna Port Conducted Measurement

#### **POWER LINE CONDUCTED EMISSION TEST:**

- Pre-Scan has been conducted to determine the worst-case mode from all possible combinations between available modulations, data rates and antenna ports (if EUT with antenna diversity architecture).
- Following channel(s) was (were) selected for the final test as listed below.

MODE	AVAILABLE CHANNEL	TESTED CHANNEL	MODULATION TECHNOLOGY	MODULATION TYPE	DATA RATE (Mbps)
802.11b	1 to 11	1	DSSS	DBPSK	1

- For conducted emissions, the EUT was tested as the following test modes:

Test Mode	Description
Mode A	Adapter 1
Mode B	Adapter 2
Mode C	Adapter 3

**RADIATED EMISSION TEST (BELOW 1 GHZ):**

- Pre-Scan has been conducted to determine the worst-case mode from all possible combinations between available modulations, data rates and antenna ports (if EUT with antenna diversity architecture).
- Following channel(s) was (were) selected for the final test as listed below.

MODE	AVAILABLE CHANNEL	TESTED CHANNEL	MODULATION TECHNOLOGY	MODULATION TYPE	DATA RATE (Mbps)
802.11b	1 to 11	1	DSSS	DBPSK	1

- For spurious emissions, the EUT was pre-tested in chamber as the following test modes:

Test Mode	Description
Mode A	Adapter 1
Mode B	Adapter 2
Mode C	Adapter 3

The worst adapter was found in Adapter 2. Their test data were recorded in this report individually.

- For spurious emissions, the EUT was tested as the following test modes:

Test Mode	Description
Mode A	Adapter 2 + Dipole antenna
Mode B	Adapter 2 + Printed antenna

**RADIATED EMISSION TEST (ABOVE 1 GHz):**

- Pre-Scan has been conducted to determine the worst-case mode from all possible combinations between available modulations, data rates and antenna ports (if EUT with antenna diversity architecture).
- Following channel(s) was (were) selected for the final test as listed below.

MODE	AVAILABLE CHANNEL	TESTED CHANNEL	MODULATION TECHNOLOGY	MODULATION TYPE	DATA RATE (Mbps)
802.11b	1 to 11	1, 6, 11	DSSS	DBPSK	1
802.11g	1 to 11	1, 6, 11	OFDM	BPSK	6

- For spurious emissions, the EUT was pre-tested in chamber as the following test modes:

Test Mode	Description
Mode A	Adapter 1
Mode B	Adapter 2
Mode C	Adapter 3

The worst adapter was found in Adapter 2. Their test data were recorded in this report individually.

- For spurious emissions, the EUT was tested as the following test modes:

Test Mode	Description
Mode A	Adapter 2 + Dipole antenna
Mode B	Adapter 2 + Printed antenna

**BANDEDGE MEASUREMENT:**

- Pre-Scan has been conducted to determine the worst-case mode from all possible combinations between available modulations, data rates and antenna ports (if EUT with antenna diversity architecture).
- Following channel(s) was (were) selected for the final test as listed below.

MODE	AVAILABLE CHANNEL	TESTED CHANNEL	MODULATION TECHNOLOGY	MODULATION TYPE	DATA RATE (Mbps)
802.11b	1 to 11	1, 11	DSSS	DBPSK	1
802.11g	1 to 11	1, 11	OFDM	BPSK	6

**ANTENNA PORT CONDUCTED MEASUREMENT:**

- Pre-Scan has been conducted to determine the worst-case mode from all possible combinations between available modulations, data rates and antenna ports (if EUT with antenna diversity architecture).
- Following channel(s) was (were) selected for the final test as listed below.

MODE	AVAILABLE CHANNEL	TESTED CHANNEL	MODULATION TECHNOLOGY	MODULATION TYPE	DATA RATE (Mbps)
802.11b	1 to 11	1, 6, 11	DSSS	DBPSK	1
802.11g	1 to 11	1, 6, 11	OFDM	BPSK	6



### **3.3 GENERAL DESCRIPTION OF APPLIED STANDARDS**

The EUT is a CTR500. According to the specifications of the manufacturer, it must comply with the requirements of the following standards:

**FCC Part 15, Subpart C. (15.247)**

**ANSI C63.4-2003**

All test items have been performed and recorded as per the above standards.

**NOTE:** The EUT is also considered as a kind of computer peripheral, because the connection to computer is necessary for typical use. It has been verified to comply with the requirements of FCC Part 15, Subpart B, Class B (DoC). The test report has been issued separately.

### 3.4 DESCRIPTION OF SUPPORT UNITS

The EUT has been tested as an independent unit together with other necessary accessories or support units. The following support units or accessories were used to form a representative test configuration during the tests.

NO.	PRODUCT	BRAND	MODEL NO.	SERIAL NO.	FCC ID
1	NOTEBOOK COMPUTER	DELL	PP18L	6976685584	DoC
2	iPod	APPLE	A1199	YM712NHUVQ5	DoC

NO.	SIGNAL CABLE DESCRIPTION OF THE ABOVE SUPPORT UNITS
1	NA
2	NA

**NOTE:** All power cords of the above support units are non shielded (1.8m).

### 3.5 CONFIGURATION OF SYSTEM UNDER TEST

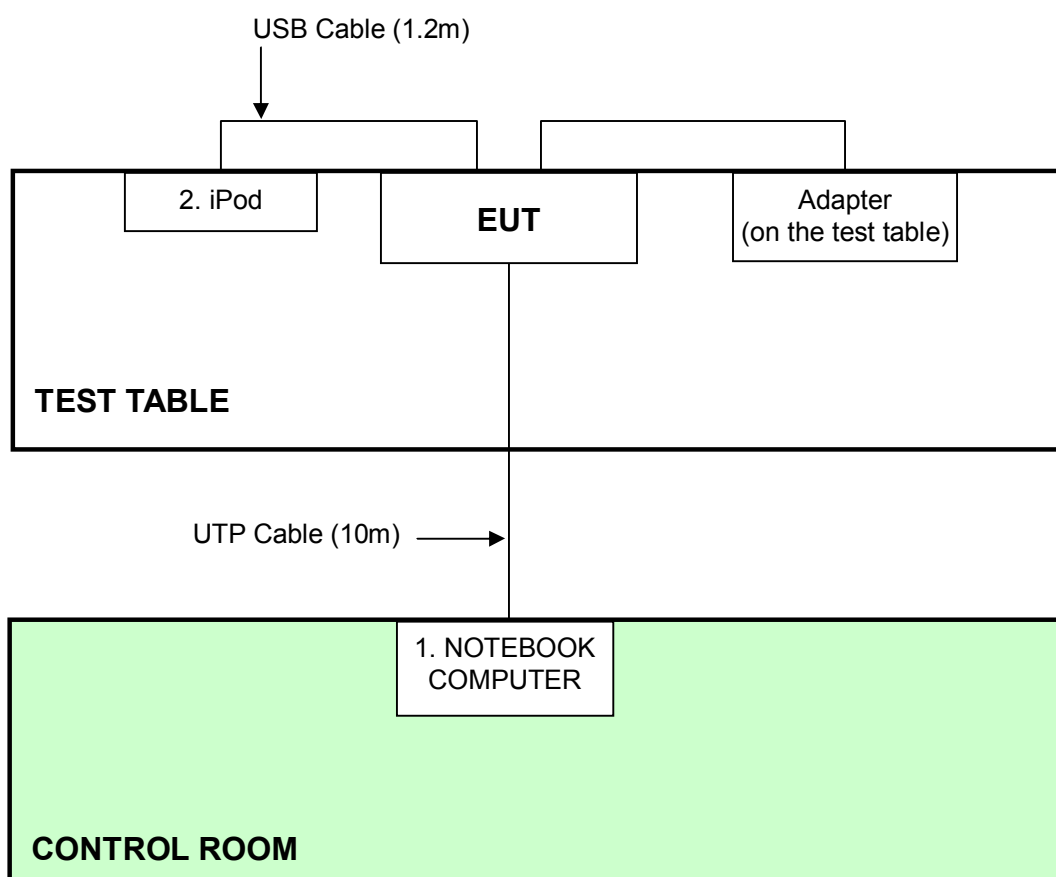

## 4. TEST TYPES AND RESULTS

### 4.1 CONDUCTED EMISSION MEASUREMENT

#### 4.1.1 LIMITS OF CONDUCTED EMISSION MEASUREMENT

FREQUENCY OF EMISSION (MHz)	CONDUCTED LIMIT (dB $\mu$ V)	
	Quasi-peak	Average
0.15-0.5	66 to 56	56 to 46
0.5-5	56	46
5-30	60	50

- NOTE:**
1. The lower limit shall apply at the transition frequencies.
  2. The limit decreases in line with the logarithm of the frequency in the range of 0.15 to 0.50 MHz.
  3. All emanations from a class A/B digital device or system, including any network of conductors and apparatus connected thereto, shall not exceed the level of field strengths specified above.

#### 4.1.2 TEST INSTRUMENTS

DESCRIPTION & MANUFACTURER	MODEL NO.	SERIAL NO.	CALIBRATED UNTIL
ROHDE & SCHWARZ Test Receiver	ESCS 30	100287	Mar. 10, 2009
Line-Impedance Stabilization Network(for EUT)	KNW-407	8-1395-12	Aug. 19, 2008
Line-Impedance Stabilization Network(for Peripheral)	ENV-216	100072	Nov. 08, 2008
RF Cable (JETBAO)	RG5B/U-6m	COACAB-9KHz-3 0MHz	Aug. 15, 2008
50 ohms Terminator	50	3	Nov. 15, 2008
Software	ADT_Cond_V7.3.2	NA	NA

- NOTE:**
1. The calibration interval of the above test instruments is 12 months and the calibrations are traceable to NML/ROC and NIST/USA.
  2. The test was performed in ADT Shielded Room No. A.
  3. The VCCI Con A Registration No. is C-817.



#### 4.1.3 TEST PROCEDURES

- a. The EUT was placed 0.4 meters from the conducting wall of the shielded room with EUT being connected to the power mains through a line impedance stabilization network (LISN). Other support units were connected to the power mains through another LISN. The two LISNs provide 50 ohm/ 50uH of coupling impedance for the measuring instrument.
- b. Both lines of the power mains connected to the EUT were checked for maximum conducted interference.
- c. The frequency range from 150kHz to 30MHz was searched. Emission levels under (Limit - 20dB) were not recorded.

#### 4.1.4 DEVIATION FROM TEST STANDARD

No deviation

#### 4.1.5 TEST SETUP

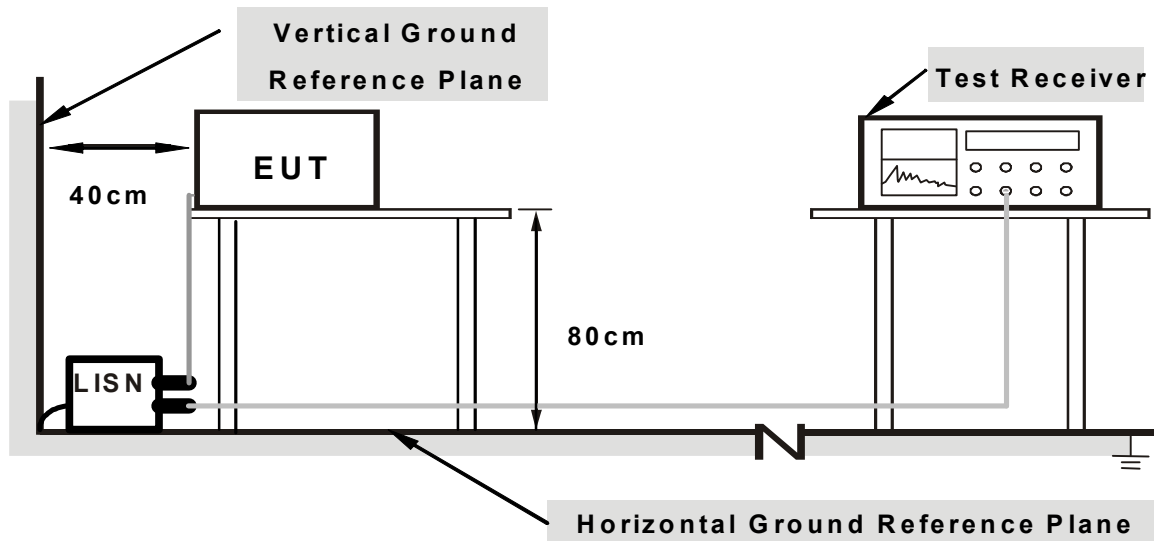

**Note: 1. Support units were connected to second LISN.**

**2. Both of LISNs (AMN) are 80 cm from EUT and at least 80 from other units and other metal planes**

For the actual test configuration, please refer to the related item – Photographs of the Test Configuration.

#### 4.1.6 EUT OPERATING CONDITIONS

1. Placed the EUT on testing table.
2. Prepared other computer systems (support unit 1) to act as communication partners and placed them outside of testing area.
3. The communication partners run test program “Web Site” to enable EUT under transmission/receiving condition continuously via UTP cable.

#### 4.1.7 TEST RESULTS

##### 802.11b DSSS MODULATION : WITH ADAPTER 1

EUT TEST CONDITION		MEASUREMENT DETAIL	
CHANNEL	Channel 1	PHASE	Line (L)
MODULATION TYPE	DBPSK	6dB BANDWIDTH	9 kHz
TRANSFER RATE	1Mbps	INPUT POWER (SYSTEM)	120Vac, 60 Hz
ENVIRONMENTAL CONDITIONS	25deg. C, 60%RH, 970hPa	TESTED BY	Andy Ho

No	Freq. [MHz]	Corr. Factor (dB)	Reading Value [dB (uV)]		Emission Level [dB (uV)]		Limit [dB (uV)]		Margin (dB)	
			Q.P.	AV.	Q.P.	AV.	Q.P.	AV.	Q.P.	AV.
	1	0.162	0.35	49.20	-	49.55	-	65.38	55.38	-15.82
2	0.181	0.35	48.47	-	48.82	-	64.43	54.43	-15.61	-
3	0.216	0.32	42.74	-	43.06	-	62.96	52.96	-19.90	-
4	2.963	0.34	30.73	-	31.07	-	56.00	46.00	-24.93	-
5	9.176	0.53	40.67	-	41.20	-	60.00	50.00	-18.80	-
6	21.605	0.90	36.42	-	37.32	-	60.00	50.00	-22.68	-

- REMARKS:**
1. Q.P. and AV. are abbreviations of quasi-peak and average individually.
  2. "-": The Quasi-peak reading value also meets average limit and measurement with the average detector is unnecessary.
  3. The emission levels of other frequencies were very low against the limit.
  4. Margin value = Emission level - Limit value
  5. Correction factor = Insertion loss + Cable loss
  6. Emission Level = Correction Factor + Reading Value.

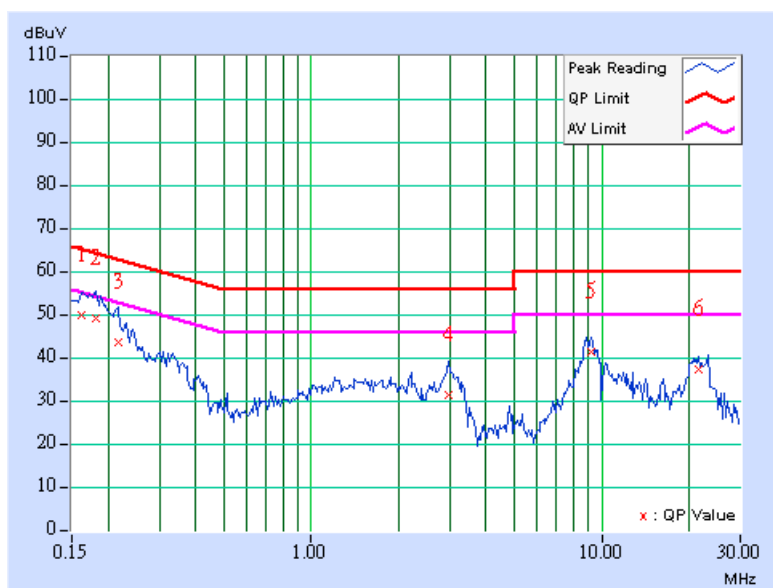

EUT TEST CONDITION		MEASUREMENT DETAIL	
CHANNEL	Channel 1	PHASE	Neutral (N)
MODULATION TYPE	DBPSK	6dB BANDWIDTH	9 kHz
TRANSFER RATE	1Mbps	INPUT POWER (SYSTEM)	120Vac, 60 Hz
ENVIRONMENTAL CONDITIONS	25deg. C, 60%RH, 970hPa	TESTED BY	Andy Ho

No	Freq. [MHz]	Corr. Factor (dB)	Reading Value [dB (uV)]		Emission Level [dB (uV)]		Limit [dB (uV)]		Margin (dB)	
			Q.P.	AV.	Q.P.	AV.	Q.P.	AV.	Q.P.	AV.
	1	0.158	0.37	49.92	-	50.29	-	65.58	55.58	-15.29
2	0.170	0.37	47.75	-	48.12	-	64.98	54.98	-16.86	-
3	0.181	0.37	48.90	-	49.27	-	64.43	54.43	-15.16	-
4	2.970	0.34	31.18	-	31.52	-	56.00	46.00	-24.48	-
5	9.304	0.52	40.49	-	41.01	-	60.00	50.00	-18.99	-
6	21.133	0.88	36.87	-	37.75	-	60.00	50.00	-22.25	-

- REMARKS:**
1. Q.P. and AV. are abbreviations of quasi-peak and average individually.
  2. "-": The Quasi-peak reading value also meets average limit and measurement with the average detector is unnecessary.
  3. The emission levels of other frequencies were very low against the limit.
  4. Margin value = Emission level - Limit value
  5. Correction factor = Insertion loss + Cable loss
  6. Emission Level = Correction Factor + Reading Value.

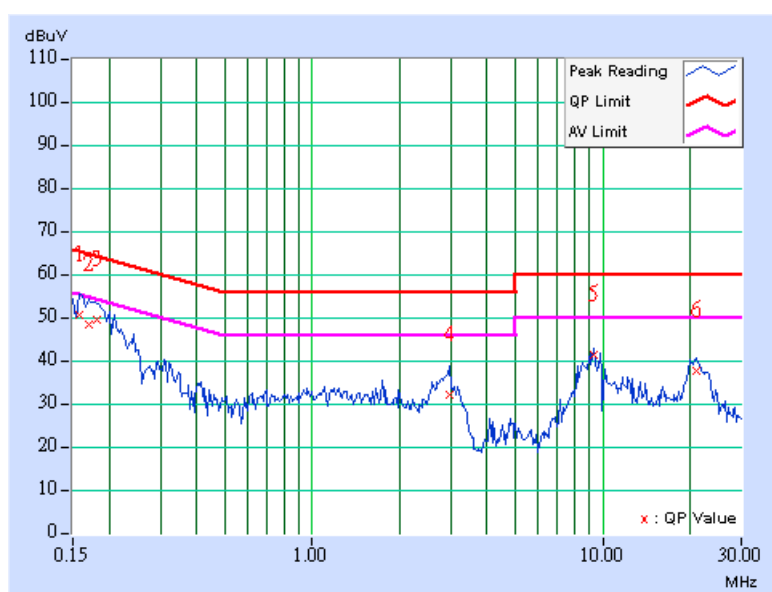

## 802.11b DSSS MODULATION: WITH ADAPTER 2

EUT TEST CONDITION		MEASUREMENT DETAIL	
CHANNEL	Channel 1	PHASE	Line (L)
MODULATION TYPE	DBPSK	6dB BANDWIDTH	9 kHz
TRANSFER RATE	1Mbps	INPUT POWER (SYSTEM)	120Vac, 60 Hz
ENVIRONMENTAL CONDITIONS	25deg. C, 60%RH, 970hPa	TESTED BY	Andy Ho

No	Freq. [MHz]	Corr. Factor (dB)	Reading Value [dB (uV)]		Emission Level [dB (uV)]		Limit [dB (uV)]		Margin (dB)	
			Q.P.	AV.	Q.P.	AV.	Q.P.	AV.	Q.P.	AV.
			1	0.162	0.35	52.11	-	52.46	-	65.38
2	0.181	0.35	52.47	-	52.82	-	64.43	54.43	-11.61	-
3	0.216	0.32	50.74	-	51.06	-	62.96	52.96	-11.90	-
4	2.963	0.34	38.25	-	38.59	-	56.00	46.00	-17.41	-
5	9.176	0.53	40.14	-	40.67	-	60.00	50.00	-19.33	-
6	21.605	0.90	37.58	-	38.48	-	60.00	50.00	-21.52	-

- REMARKS:**
1. Q.P. and AV. are abbreviations of quasi-peak and average individually.
  2. "-": The Quasi-peak reading value also meets average limit and measurement with the average detector is unnecessary.
  3. The emission levels of other frequencies were very low against the limit.
  4. Margin value = Emission level - Limit value
  5. Correction factor = Insertion loss + Cable loss
  6. Emission Level = Correction Factor + Reading Value.

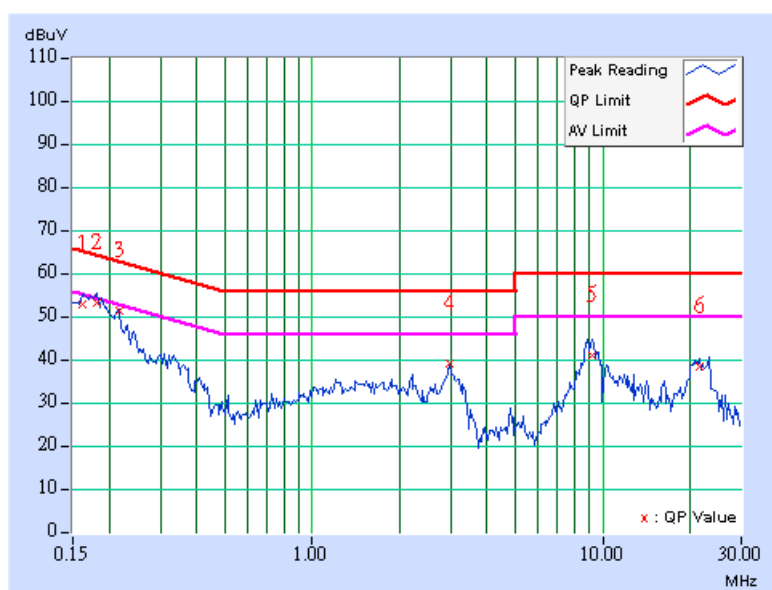

EUT TEST CONDITION		MEASUREMENT DETAIL	
CHANNEL	Channel 6	PHASE	Neutral (N)
MODULATION TYPE	DBPSK	6dB BANDWIDTH	9 kHz
TRANSFER RATE	1Mbps	INPUT POWER (SYSTEM)	120Vac, 60 Hz
ENVIRONMENTAL CONDITIONS	25deg. C, 60%RH, 970hPa	TESTED BY	Andy Ho

No	Freq. [MHz]	Corr. Factor (dB)	Reading Value [dB (uV)]		Emission Level [dB (uV)]		Limit [dB (uV)]		Margin (dB)	
			Q.P.	AV.	Q.P.	AV.	Q.P.	AV.	Q.P.	AV.
	1	0.158	0.37	51.25	-	51.62	-	65.58	55.58	-13.96
2	0.181	0.37	48.32	-	48.69	-	64.43	54.43	-15.74	-
3	0.244	0.30	40.62	-	40.92	-	61.97	51.97	-21.05	-
4	2.970	0.34	32.65	-	32.99	-	56.00	46.00	-23.01	-
5	9.304	0.52	41.33	-	41.85	-	60.00	50.00	-18.15	-
6	21.133	0.88	37.62	-	38.50	-	60.00	50.00	-21.50	-

- REMARKS:**
1. Q.P. and AV. are abbreviations of quasi-peak and average individually.
  2. "-": The Quasi-peak reading value also meets average limit and measurement with the average detector is unnecessary.
  3. The emission levels of other frequencies were very low against the limit.
  4. Margin value = Emission level - Limit value
  5. Correction factor = Insertion loss + Cable loss
  6. Emission Level = Correction Factor + Reading Value.

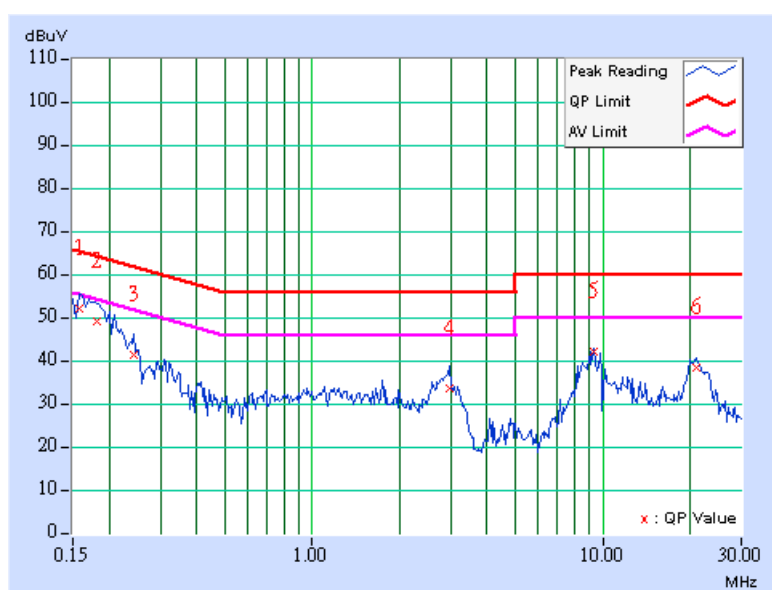

### 802.11b DSSS MODULATION: WITH ADAPTER 3

EUT TEST CONDITION		MEASUREMENT DETAIL	
CHANNEL	Channel 1	PHASE	Line (L)
MODULATION TYPE	DBPSK	6dB BANDWIDTH	9 kHz
TRANSFER RATE	1Mbps	INPUT POWER (SYSTEM)	120Vac, 60 Hz
ENVIRONMENTAL CONDITIONS	25deg. C, 60%RH, 970hPa	TESTED BY	Andy Ho

No	Freq. [MHz]	Corr. Factor (dB)	Reading Value [dB (uV)]		Emission Level [dB (uV)]		Limit [dB (uV)]		Margin (dB)	
			Q.P.	AV.	Q.P.	AV.	Q.P.	AV.	Q.P.	AV.
			1	0.193	0.34	41.38	-	41.72	-	63.91
2	0.259	0.27	34.12	-	34.39	-	61.47	51.47	-27.08	-
3	0.384	0.12	36.12	-	36.24	-	58.18	48.18	-21.95	-
4	0.513	0.14	35.50	-	35.64	-	56.00	46.00	-20.36	-
5	0.767	0.23	32.40	-	32.63	-	56.00	46.00	-23.37	-
6	8.769	0.52	30.93	-	31.45	-	60.00	50.00	-28.55	-

- REMARKS:**
1. Q.P. and AV. are abbreviations of quasi-peak and average individually.
  2. "-": The Quasi-peak reading value also meets average limit and measurement with the average detector is unnecessary.
  3. The emission levels of other frequencies were very low against the limit.
  4. Margin value = Emission level - Limit value
  5. Correction factor = Insertion loss + Cable loss
  6. Emission Level = Correction Factor + Reading Value.

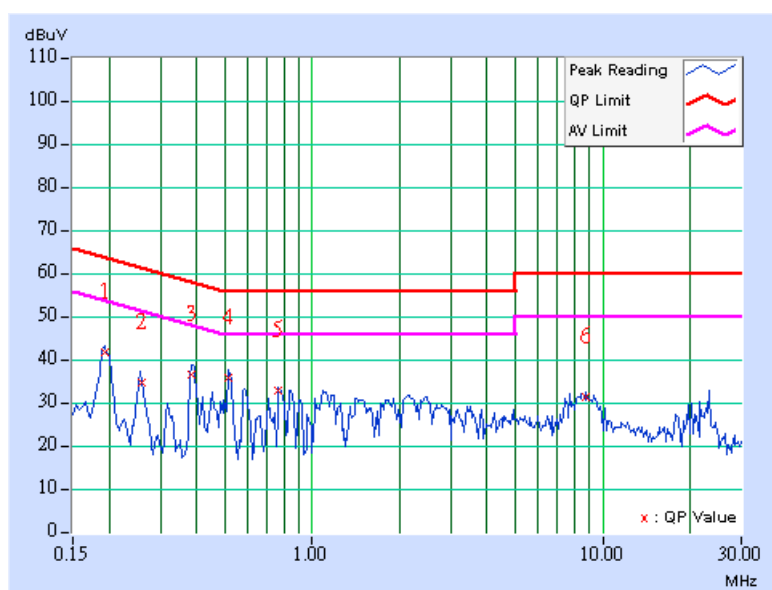

EUT TEST CONDITION		MEASUREMENT DETAIL	
CHANNEL	Channel 6	PHASE	Neutral (N)
MODULATION TYPE	DBPSK	6dB BANDWIDTH	9 kHz
TRANSFER RATE	1Mbps	INPUT POWER (SYSTEM)	120Vac, 60 Hz
ENVIRONMENTAL CONDITIONS	25deg. C, 60%RH, 970hPa	TESTED BY	Andy Ho

No	Freq. [MHz]	Corr. Factor (dB)	Reading Value [dB (uV)]		Emission Level [dB (uV)]		Limit [dB (uV)]		Margin (dB)	
			Q.P.	AV.	Q.P.	AV.	Q.P.	AV.	Q.P.	AV.
	1	0.197	0.36	45.61	-	45.97	-	63.74	53.74	-17.77
2	0.264	0.27	36.83	-	37.10	-	61.31	51.31	-24.20	-
3	0.384	0.11	37.66	-	37.77	-	58.18	48.18	-20.41	-
4	0.451	0.11	34.29	-	34.40	-	56.86	46.86	-22.46	-
5	0.580	0.16	32.91	-	33.07	-	56.00	46.00	-22.93	-
6	2.509	0.31	27.49	-	27.80	-	56.00	46.00	-28.20	-

- REMARKS:**
1. Q.P. and AV. are abbreviations of quasi-peak and average individually.
  2. "-": The Quasi-peak reading value also meets average limit and measurement with the average detector is unnecessary.
  3. The emission levels of other frequencies were very low against the limit.
  4. Margin value = Emission level - Limit value
  5. Correction factor = Insertion loss + Cable loss
  6. Emission Level = Correction Factor + Reading Value.

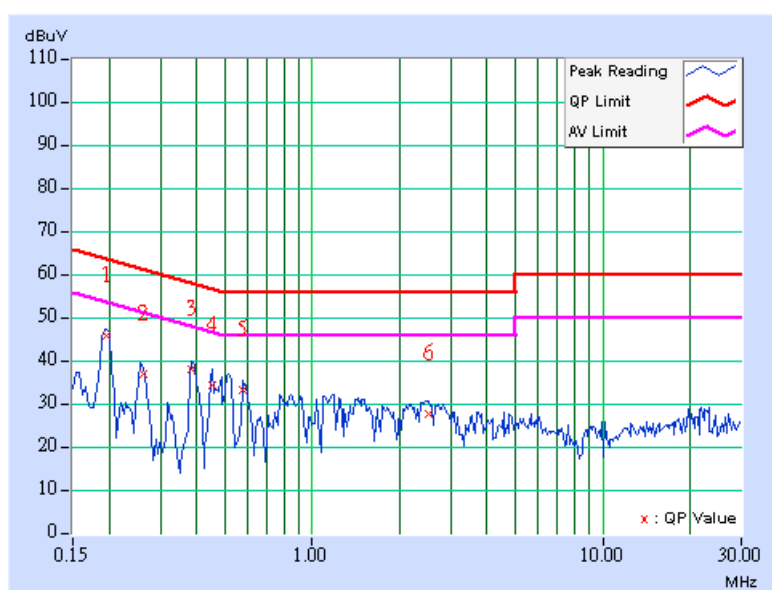



## 4.2 RADIATED EMISSION MEASUREMENT

### 4.2.1 LIMITS OF RADIATED EMISSION MEASUREMENT

Emissions radiated outside of the specified bands, shall be according to the general radiated limits in 15.209 as following:

Frequencies (MHz)	Field strength (microvolts/meter)	Measurement distance (meters)
0.009-0.490	2400/F(kHz)	300
0.490-1.705	24000/F(kHz)	30
1.705-30.0	30	30
30-88	100	3
88-216	150	3
216-960	200	3
Above 960	500	3

**NOTE:**

1. The lower limit shall apply at the transition frequencies.
2. Emission level (dBuV/m) = 20 log Emission level (uV/m).
3. As shown in 15.35(b), for frequencies above 1000MHz, the field strength limits are based on average detector, however, the peak field strength of any emission shall not exceed the maximum permitted average limits, specified above by more than 20dB under any condition of modulation.



#### 4.2.2 TEST INSTRUMENTS

DESCRIPTION & MANUFACTURER	MODEL NO.	SERIAL NO.	CALIBRATED UNTIL
ADVANTEST Spectrum Analyzer	R3271A	85060311	July 15, 2008
HP Pre_Amplifier	8449B	3008A01922	Oct. 04, 2008
ROHDE & SCHWARZ Test Receiver	ESCS30	100375	Mar. 31, 2009
SCHWARZBECK TRILOG Broadband Antenna	VULB 9168	138	July 26, 2008
Schwarzbeck Horn_Antenna	BBHA9120	D124	Dec. 16, 2008
Schwarzbeck Horn_Antenna	BBHA 9170	BBHA9170153	Jan. 27, 2009
R&S Loop Antenna	HFH2-Z2	100070	Jan. 13, 2009
RF Switches (ARNITSU)	CS-201	1565157	Aug. 13, 2008
RF CABLE (Chaintek)	SF102	22054-2	Dec. 06. 2008
RF Cable(RICHTEC)	9913-30M N-N Cable	STCCAB-30M-1 GHz	Aug. 13, 2008
Software	ADT_Radiated_V 7.6.15.8	NA	NA
CHANCE MOST Antenna Tower	AT-100	0203	NA
CHANCE MOST Turn Table	TT-100	0203	NA

- Note: 1. The calibration interval of the above test instruments is 12 months and the calibrations are traceable to NML/ROC and NIST/USA.
2. The horn antenna, HP preamplifier (model: 8449B) and Spectrum Analyzer (model: R3271A) are used only for the measurement of emission frequency above 1GHz if tested.
3. The test was performed in ADT Open Site No. C.
4. The FCC Site Registration No. is 656396.
5. The VCCI Site Registration No. is R-1626.
6. The CANADA Site Registration No. is IC 3789C-3.

### 4.2.3 TEST PROCEDURES

- a. The EUT was placed on the top of a rotating table 0.8 meters above the ground at a 3 meter semi- anechoic. The table was rotated 360 degrees to determine the position of the highest radiation.
- b. The EUT was set 3 meters away from the interference-receiving antenna, which was mounted on the top of a variable-height antenna tower.
- c. The antenna is a broadband antenna, and its height is varied from one meter to four meters above the ground to determine the maximum value of the field strength. Both horizontal and vertical polarizations of the antenna are set to make the measurement.
- d. For each suspected emission, the EUT was arranged to its worst case and then the antenna was tuned to heights from 1 meter to 4 meters and the rotatable table was turned from 0 degrees to 360 degrees to find the maximum reading.
- e. The test-receiver system was set to Peak Detect Function and Specified Bandwidth with Maximum Hold Mode.
- f. If the emission level of the EUT in peak mode was 10 dB lower than the limit specified, then testing could be stopped and the peak values of the EUT would be reported. Otherwise the emissions that did not have 10 dB margin would be re-tested one by one using the quasi-peak method or average method as specified and then reported in Data sheet peak mode and QP mode.

**NOTE:**

1. The resolution bandwidth and video bandwidth of test receiver/spectrum analyzer is 120kHz for Peak detection (PK) and Quasi-peak detection (QP) at frequency below 1GHz.
2. The resolution bandwidth of test receiver/spectrum analyzer is 1 MHz and the video bandwidth is 3 MHz for Peak detection (PK) at frequency above 1GHz.
3. The resolution bandwidth of test receiver/spectrum analyzer is 1 MHz and the video bandwidth is 10 Hz for Average detection (AV) at frequency above 1GHz.

### 4.2.4 DEVIATION FROM TEST STANDARD

No deviation

#### 4.2.5 TEST SETUP

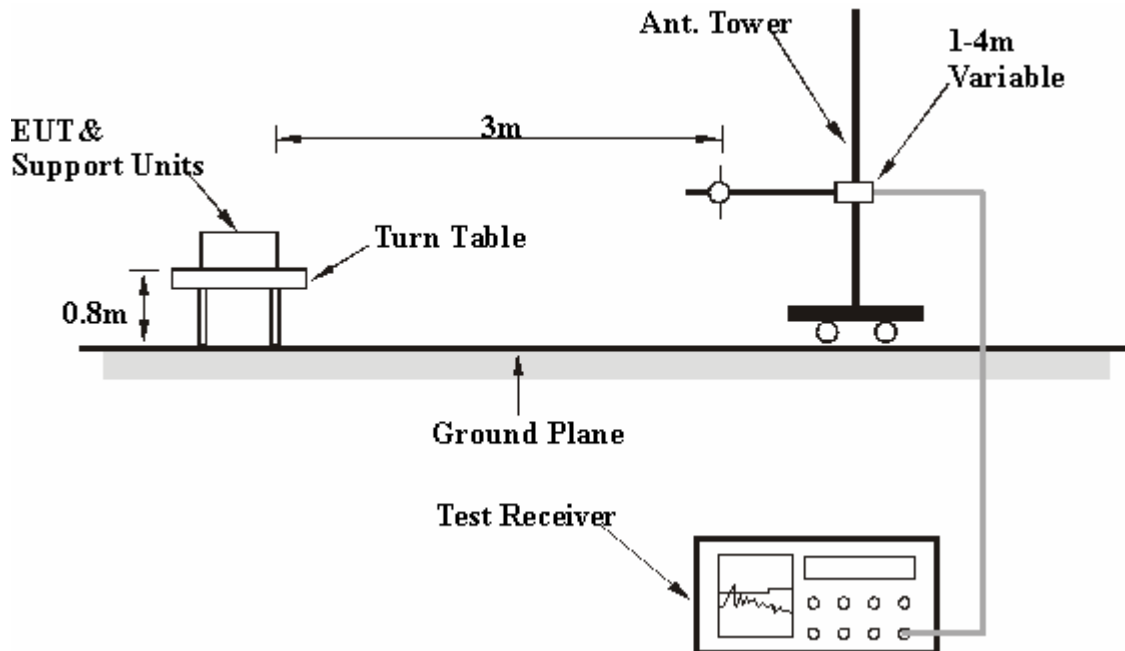

For the actual test configuration, please refer to the related item – Photographs of the Test Configuration.

#### 4.2.6 EUT OPERATING CONDITIONS

Same as 4.1.6

## 4.2.7 TEST RESULTS

### BELOW 1GHz WORST-CASE DATA : 802.11b DSSS MODULATION

EUT TEST CONDITION		MEASUREMENT DETAIL	
CHANNEL	Channel 1	FREQUENCY RANGE	30 ~ 1000MHz
INPUT POWER	120Vac, 60 Hz	DETECTOR FUNCTION	Peak (PK) Average (AV)
ENVIRONMENTAL CONDITIONS	29deg. C, 59%RH 970hPa	TESTED BY	Rex Huang
TEST MODE	Adapter 2 + Dipole antenna		

ANTENNA POLARITY & TEST DISTANCE: HORIZONTAL AT 3 M								
NO.	FREQ. (MHz)	EMISSION LEVEL (dBuV/m)	LIMIT (dBuV/m)	MARGIN (dB)	ANTENNA HEIGHT (m)	TABLE ANGLE (Degree)	RAW VALUE (dBuV)	CORRECTION FACTOR (dB/m)
1	200.00	28.87 QP	43.50	-14.63	1.00 H	217	16.84	12.03
2	250.00	36.34 QP	46.00	-9.66	1.00 H	247	23.51	12.83
3	300.00	31.43 QP	46.00	-14.57	1.09 H	122	14.84	16.59
4	400.00	34.26 QP	46.00	-11.74	1.00 H	307	16.21	18.05
5	500.00	33.67 QP	46.00	-12.33	1.08 H	114	12.62	21.05
6	625.00	32.49 QP	46.00	-13.51	1.00 H	149	8.49	24.00
7	750.04	34.37 QP	46.00	-11.63	1.00 H	7	7.11	27.26
8	875.04	31.79 QP	46.00	-14.21	1.00 H	117	2.72	29.07
9	1000.04	32.46 QP	54.00	-21.54	1.08 H	264	1.93	30.53
ANTENNA POLARITY & TEST DISTANCE: VERTICAL AT 3 M								
NO.	FREQ. (MHz)	EMISSION LEVEL (dBuV/m)	LIMIT (dBuV/m)	MARGIN (dB)	ANTENNA HEIGHT (m)	TABLE ANGLE (Degree)	RAW VALUE (dBuV)	CORRECTION FACTOR (dB/m)
1	69.11	29.43 QP	40.00	-10.57	1.00 V	24	17.27	12.16
2	250.00	35.37 QP	46.00	-10.63	1.10 V	258	22.54	12.83
3	300.00	26.58 QP	46.00	-19.42	1.45 V	11	9.99	16.59
4	400.00	29.69 QP	46.00	-16.31	1.00 V	334	11.64	18.05
5	500.00	26.78 QP	46.00	-19.22	1.10 V	180	5.73	21.05
6	625.01	32.34 QP	46.00	-13.66	1.00 V	102	8.34	24.00
7	750.01	33.41 QP	46.00	-12.59	1.00 V	149	6.15	27.26
8	875.05	31.49 QP	46.00	-14.51	1.10 V	159	2.42	29.07
9	1000.05	34.67 QP	54.00	-19.33	1.12 V	301	4.14	30.53

**REMARKS:** 1. Emission level (dBuV/m) = Raw Value (dBuV) + Correction Factor (dB/m).

2. Correction Factor (dB/m) = Antenna Factor (dB/m) + Cable Factor (dB).

3. The other emission levels were very low against the limit.

4. Margin value = Emission level – Limit value.

EUT TEST CONDITION		MEASUREMENT DETAIL	
CHANNEL	Channel 1	FREQUENCY RANGE	30 ~ 1000MHz
INPUT POWER (SYSTEM)	120Vac, 60 Hz	DETECTOR FUNCTION	Peak (PK) Average (AV)
ENVIRONMENTAL CONDITIONS	29deg. C, 59%RH 970hPa	TESTED BY	Rex Huang
TEST MODE	Adapter 2 + Printed antenna		

ANTENNA POLARITY & TEST DISTANCE: HORIZONTAL AT 3 M								
NO.	FREQ. (MHz)	EMISSION LEVEL (dBuV/m)	LIMIT (dBuV/m)	MARGIN (dB)	ANTENNA HEIGHT (m)	TABLE ANGLE (Degree)	RAW VALUE (dBuV)	CORRECTION FACTOR (dB/m)
1	250.00	30.48 QP	46.00	-15.52	1.15 H	72	17.65	12.83
2	400.00	34.62 QP	46.00	-11.38	1.00 H	313	16.57	18.05
3	500.00	29.37 QP	46.00	-16.63	1.70 H	61	8.32	21.05
4	625.00	32.44 QP	46.00	-13.56	1.46 H	280	8.44	24.00
5	750.04	36.53 QP	46.00	-9.47	1.56 H	116	9.27	27.26
6	875.04	31.61 QP	46.00	-14.39	1.58 H	21	2.54	29.07
7	1000.04	31.49 QP	54.00	-22.51	1.00 H	47	0.96	30.53
ANTENNA POLARITY & TEST DISTANCE: VERTICAL AT 3 M								
NO.	FREQ. (MHz)	EMISSION LEVEL (dBuV/m)	LIMIT (dBuV/m)	MARGIN (dB)	ANTENNA HEIGHT (m)	TABLE ANGLE (Degree)	RAW VALUE (dBuV)	CORRECTION FACTOR (dB/m)
1	50.30	29.71 QP	40.00	-10.29	1.00 V	21	13.83	15.88
2	250.00	31.59 QP	46.00	-14.41	1.00 V	260	18.76	12.83
3	400.00	31.46 QP	46.00	-14.54	1.07 V	1	13.41	18.05
4	500.00	26.98 QP	46.00	-19.02	1.08 V	68	5.93	21.05
5	750.02	33.84 QP	46.00	-12.16	1.15 V	313	6.58	27.26
6	875.02	31.46 QP	46.00	-14.54	1.31 V	323	2.39	29.07
7	1000.02	33.42 QP	54.00	-20.58	1.09 V	304	2.89	30.53

- REMARKS:**
1. Emission level (dBuV/m) = Raw Value (dBuV) + Correction Factor (dB/m).
  2. Correction Factor (dB/m) = Antenna Factor (dB/m) + Cable Factor (dB).
  3. The other emission levels were very low against the limit.
  4. Margin value = Emission level – Limit value.

## Above 1GHz Test Data

### 4.2.8 TEST RESULTS

#### 802.11b DSSS MODULATION – adapter 2 + Dipole antenna

EUT TEST CONDITION		MEASUREMENT DETAIL	
CHANNEL	Channel 1	FREQUENCY RANGE	1 ~ 25GHz
INPUT POWER (SYSTEM)	120Vac, 60 Hz	DETECTOR FUNCTION	Peak (PK) Average (AV)
ENVIRONMENTAL CONDITIONS	29deg. C, 59%RH 970hPa	TESTED BY	Rex Huang

ANTENNA POLARITY & TEST DISTANCE: HORIZONTAL AT 3 M								
NO.	FREQ. (MHz)	EMISSION LEVEL (dBuV/m)	LIMIT (dBuV/m)	MARGIN (dB)	ANTENNA HEIGHT (m)	TABLE ANGLE (Degree)	RAW VALUE (dBuV)	CORRECTION FACTOR (dB/m)
1	2288.00	43.50 PK	74.00	-30.50	1.00 H	326	13.62	29.88
2	2288.00	35.40 AV	54.00	-18.60	1.00 H	326	5.52	29.88
3	2390.00	54.13 PK	74.00	-19.87	1.45 H	330	23.81	30.32
4	2390.00	43.00 AV	54.00	-11.00	1.45 H	330	12.68	30.32
5	*2412.00	98.10 PK			1.45 H	330	67.69	30.41
6	*2412.00	93.20 AV			1.45 H	330	62.79	30.41
7	4824.00	54.60 PK	74.00	-19.40	1.76 H	168	18.81	35.79
8	4824.00	51.30 AV	54.00	-2.70	1.76 H	168	15.51	35.79
9	7236.00	52.70 PK	78.10	-25.40	1.35 H	60	11.10	41.60
10	7236.00	39.60 AV	73.20	-33.60	1.35 H	60	-2.00	41.60

ANTENNA POLARITY & TEST DISTANCE: VERTICAL AT 3 M								
NO.	FREQ. (MHz)	EMISSION LEVEL (dBuV/m)	LIMIT (dBuV/m)	MARGIN (dB)	ANTENNA HEIGHT (m)	TABLE ANGLE (Degree)	RAW VALUE (dBuV)	CORRECTION FACTOR (dB/m)
1	2288.00	51.40 PK	74.00	-22.60	1.45 V	264	21.52	29.88
2	2288.00	48.20 AV	54.00	-5.80	1.45 V	264	18.32	29.88
3	2390.00	55.82 PK	74.00	-18.18	1.40 V	108	25.50	30.32
4	2390.00	43.99 AV	54.00	-10.01	1.40 V	108	13.67	30.32
5	*2412.00	109.20 PK			1.40 V	108	78.79	30.41
6	*2412.00	104.40 AV			1.40 V	108	73.99	30.41
7	4824.00	56.20 PK	74.00	-17.80	1.45 V	136	20.41	35.79
8	<b>4824.00</b>	<b>53.50 AV</b>	<b>54.00</b>	<b>-0.50</b>	<b>1.45 V</b>	<b>136</b>	<b>17.71</b>	<b>35.79</b>
9	7236.00	53.20 PK	89.20	-36.00	1.21 V	114	11.60	41.60
10	7236.00	40.70 AV	84.40	-43.70	1.21 V	114	-0.90	41.60

- REMARKS:**
1. Emission level (dBuV/m) = Raw Value (dBuV) + Correction Factor (dB/m).
  2. Correction Factor (dB/m) = Antenna Factor (dB/m) + Cable Factor (dB).
  3. The other emission levels were very low against the limit.
  4. Margin value = Emission level – Limit value.
  5. “ \* “: Fundamental frequency.

EUT TEST CONDITION		MEASUREMENT DETAIL	
CHANNEL	Channel 6	FREQUENCY RANGE	1 ~ 25GHz
INPUT POWER (SYSTEM)	120Vac, 60 Hz	DETECTOR FUNCTION	Peak (PK) Average (AV)
ENVIRONMENTAL CONDITIONS	29deg. C, 59%RH 970hPa	TESTED BY	Rex Huang

ANTENNA POLARITY & TEST DISTANCE: HORIZONTAL AT 3 M								
NO.	FREQ. (MHz)	EMISSION LEVEL (dBuV/m)	LIMIT (dBuV/m)	MARGIN (dB)	ANTENNA HEIGHT (m)	TABLE ANGLE (Degree)	RAW VALUE (dBuV)	CORRECTION FACTOR (dB/m)
1	2288.00	43.70 PK	74.00	-30.30	1.00 H	327	13.82	29.88
2	2288.00	35.70 AV	54.00	-18.30	1.00 H	327	5.82	29.88
3	*2437.00	97.10 PK			1.49 H	342	66.58	30.52
4	*2437.00	92.40 AV			1.49 H	342	61.88	30.52
5	4874.00	55.70 PK	74.00	-18.30	1.63 H	174	19.78	35.92
6	4874.00	52.60 AV	54.00	-1.40	1.63 H	174	16.68	35.92
7	7311.00	52.20 PK	74.00	-21.80	1.34 H	52	10.39	41.81
8	7311.00	38.90 AV	54.00	-15.10	1.34 H	52	-2.91	41.81
ANTENNA POLARITY & TEST DISTANCE: VERTICAL AT 3 M								
NO.	FREQ. (MHz)	EMISSION LEVEL (dBuV/m)	LIMIT (dBuV/m)	MARGIN (dB)	ANTENNA HEIGHT (m)	TABLE ANGLE (Degree)	RAW VALUE (dBuV)	CORRECTION FACTOR (dB/m)
1	2288.00	52.40 PK	74.00	-21.60	1.45 V	86	22.52	29.88
2	2288.00	48.60 AV	54.00	-5.40	1.45 V	86	18.72	29.88
3	*2437.00	108.60 PK			1.38 V	110	78.08	30.52
4	*2437.00	104.00 AV			1.38 V	110	73.48	30.52
5	4874.00	54.80 PK	74.00	-19.20	1.36 V	165	18.88	35.92
6	4874.00	52.00 AV	54.00	-2.00	1.36 V	165	16.08	35.92
7	7311.00	52.80 PK	74.00	-21.20	1.15 V	123	10.99	41.81
8	7311.00	40.10 AV	54.00	-13.90	1.15 V	123	-1.71	41.81

- REMARKS:**
1. Emission level (dBuV/m) = Raw Value (dBuV) + Correction Factor (dB/m).
  2. Correction Factor (dB/m) = Antenna Factor (dB/m) + Cable Factor (dB).
  3. The other emission levels were very low against the limit.
  4. Margin value = Emission level – Limit value.
  5. “ \* “: Fundamental frequency.



EUT TEST CONDITION		MEASUREMENT DETAIL	
CHANNEL	Channel 11	FREQUENCY RANGE	1 ~ 25GHz
INPUT POWER (SYSTEM)	120Vac, 60 Hz	DETECTOR FUNCTION	Peak (PK) Average (AV)
ENVIRONMENTAL CONDITIONS	29deg. C, 59%RH 970hPa	TESTED BY	Rex Huang

ANTENNA POLARITY & TEST DISTANCE: HORIZONTAL AT 3 M								
NO.	FREQ. (MHz)	EMISSION LEVEL (dBuV/m)	LIMIT (dBuV/m)	MARGIN (dB)	ANTENNA HEIGHT (m)	TABLE ANGLE (Degree)	RAW VALUE (dBuV)	CORRECTION FACTOR (dB/m)
1	2288.00	43.50 PK	74.00	-30.50	1.00 H	331	13.62	29.88
2	2288.00	35.70 AV	54.00	-18.30	1.00 H	331	5.82	29.88
3	*2462.00	92.50 PK			1.46 H	345	61.87	30.63
4	*2462.00	87.20 AV			1.46 H	345	56.57	30.63
5	2483.50	55.56 PK	74.00	-18.44	1.46 H	345	24.84	30.72
6	2483.50	43.00 AV	54.00	-11.00	1.46 H	345	12.28	30.72
7	4924.00	55.90 PK	74.00	-18.10	1.73 H	176	19.84	36.06
8	4924.00	53.20 AV	54.00	-0.80	1.73 H	176	17.14	36.06
9	7386.00	52.50 PK	74.00	-21.50	1.37 H	43	10.49	42.01
10	7386.00	39.40 AV	54.00	-14.60	1.37 H	43	-2.61	42.01
ANTENNA POLARITY & TEST DISTANCE: VERTICAL AT 3 M								
NO.	FREQ. (MHz)	EMISSION LEVEL (dBuV/m)	LIMIT (dBuV/m)	MARGIN (dB)	ANTENNA HEIGHT (m)	TABLE ANGLE (Degree)	RAW VALUE (dBuV)	CORRECTION FACTOR (dB/m)
1	2288.00	52.20 PK	74.00	-21.80	1.44 V	83	22.32	29.88
2	2288.00	48.50 AV	54.00	-5.50	1.44 V	83	18.62	29.88
3	*2462.00	105.00 PK			1.38 V	110	74.37	30.63
4	*2462.00	100.40 AV			1.38 V	110	69.77	30.63
5	2483.50	54.17 PK	74.00	-19.83	1.38 V	110	23.45	30.72
6	2483.50	43.25 AV	54.00	-10.75	1.38 V	110	12.53	30.72
7	4924.00	54.60 PK	74.00	-19.40	1.23 V	93	18.54	36.06
8	4924.00	51.30 AV	54.00	-2.70	1.23 V	93	15.24	36.06
9	7386.00	53.10 PK	74.00	-20.90	1.16 V	119	11.09	42.01
10	7386.00	40.50 AV	54.00	-13.50	1.16 V	119	-1.51	42.01

- REMARKS:**
1. Emission level (dBuV/m) = Raw Value (dBuV) + Correction Factor (dB/m).
  2. Correction Factor (dB/m) = Antenna Factor (dB/m) + Cable Factor (dB).
  3. The other emission levels were very low against the limit.
  4. Margin value = Emission level – Limit value.
  5. “ \* “: Fundamental frequency.

# RESTRICTED BANDEDGE (802.11b MODE, CH1, HORIZONTAL )

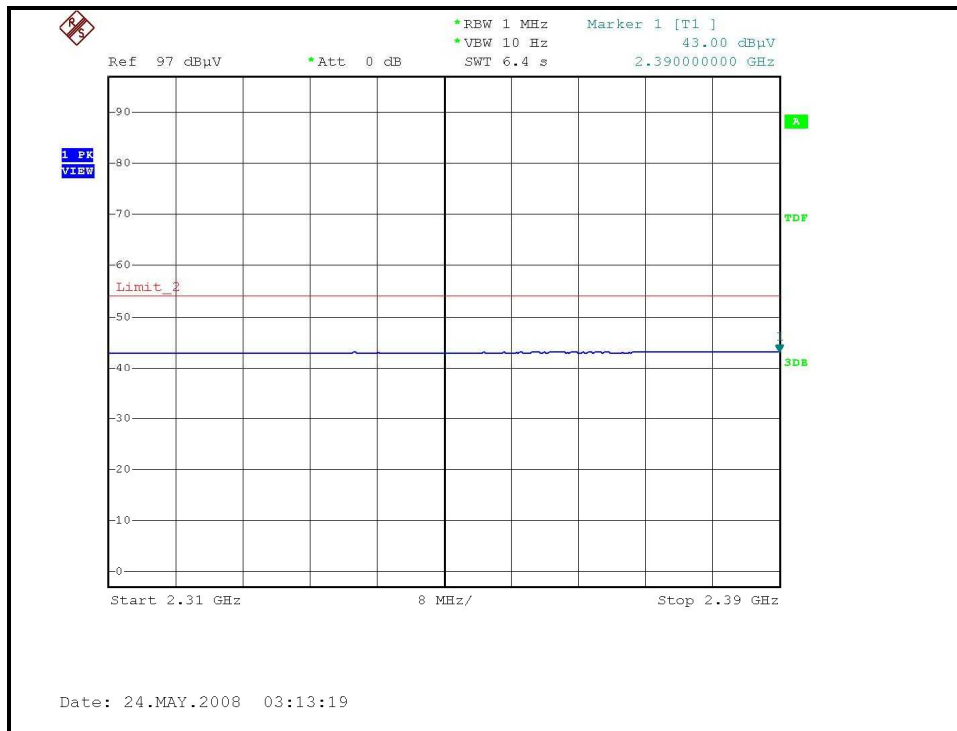
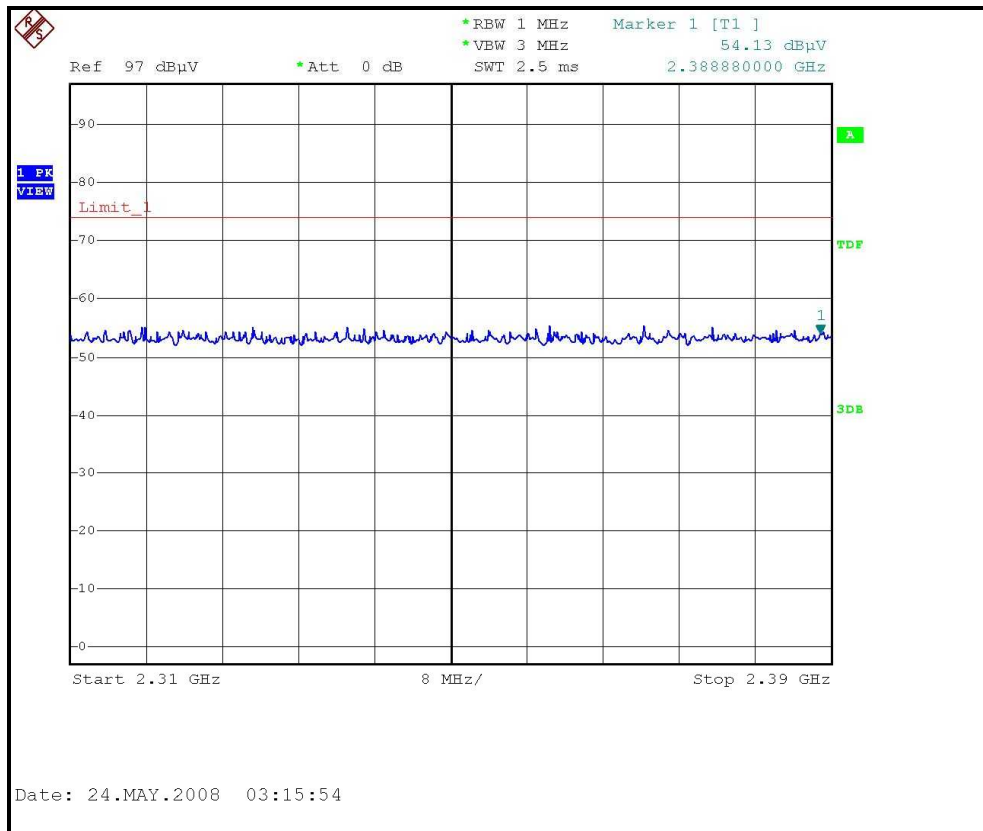

RESTRICTED BANDEDGE (802.11b MODE, CH1, VERTICAL )

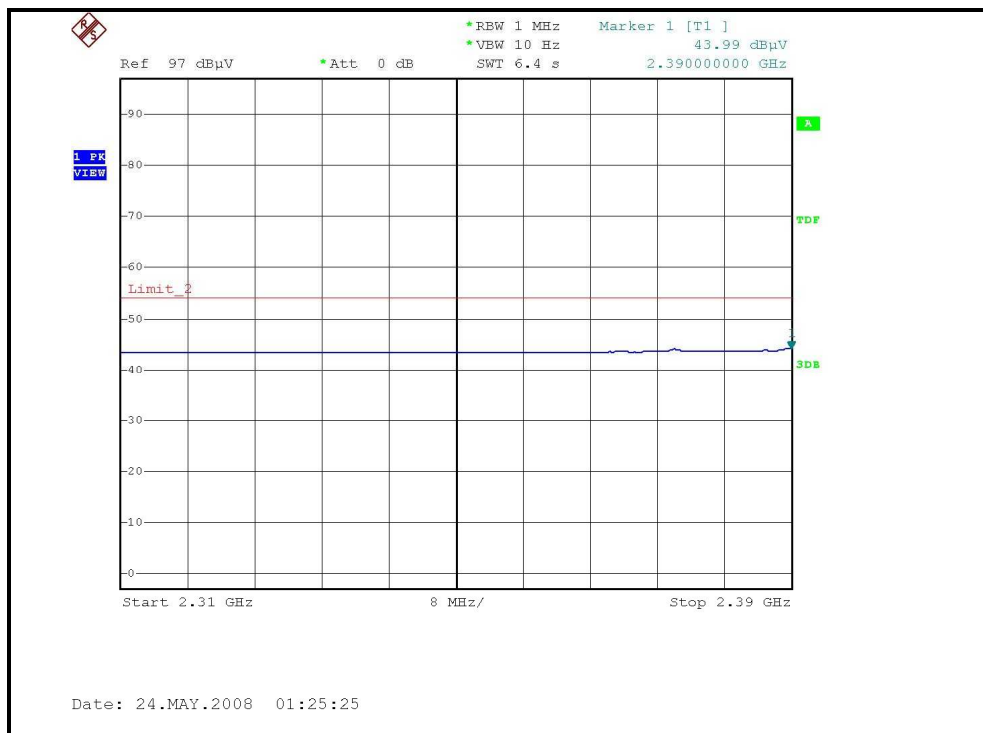
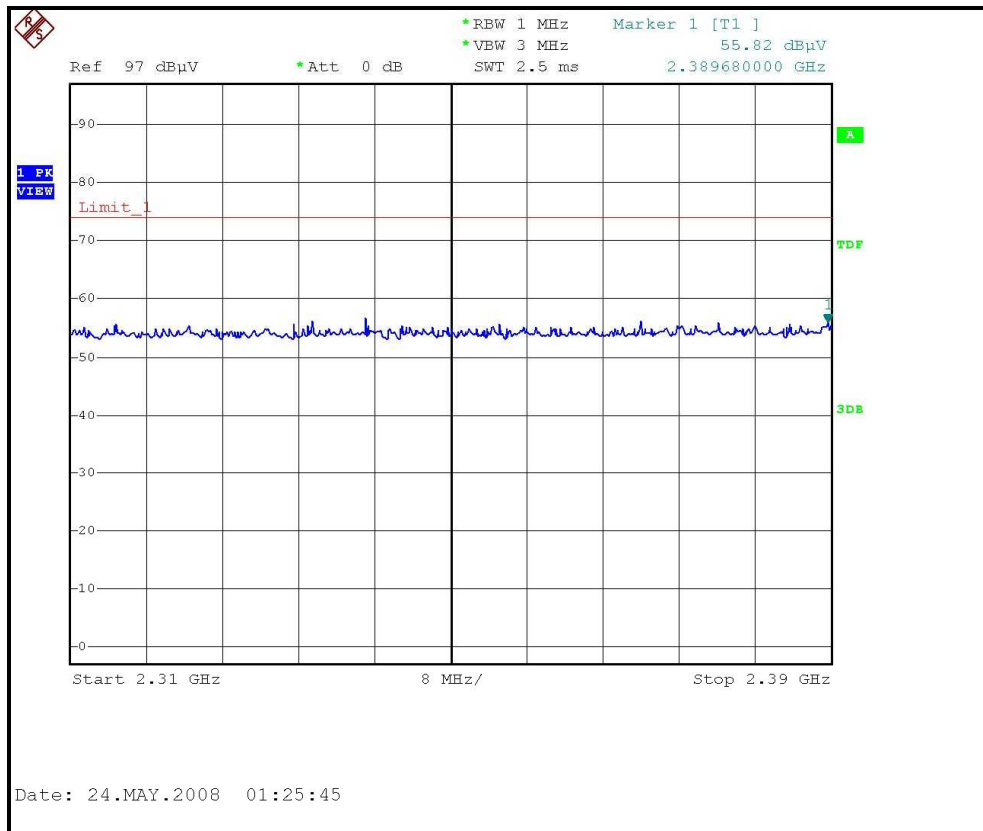

RESTRICTED BANDEDGE (802.11b MODE,CH11, HORIZONTAL )

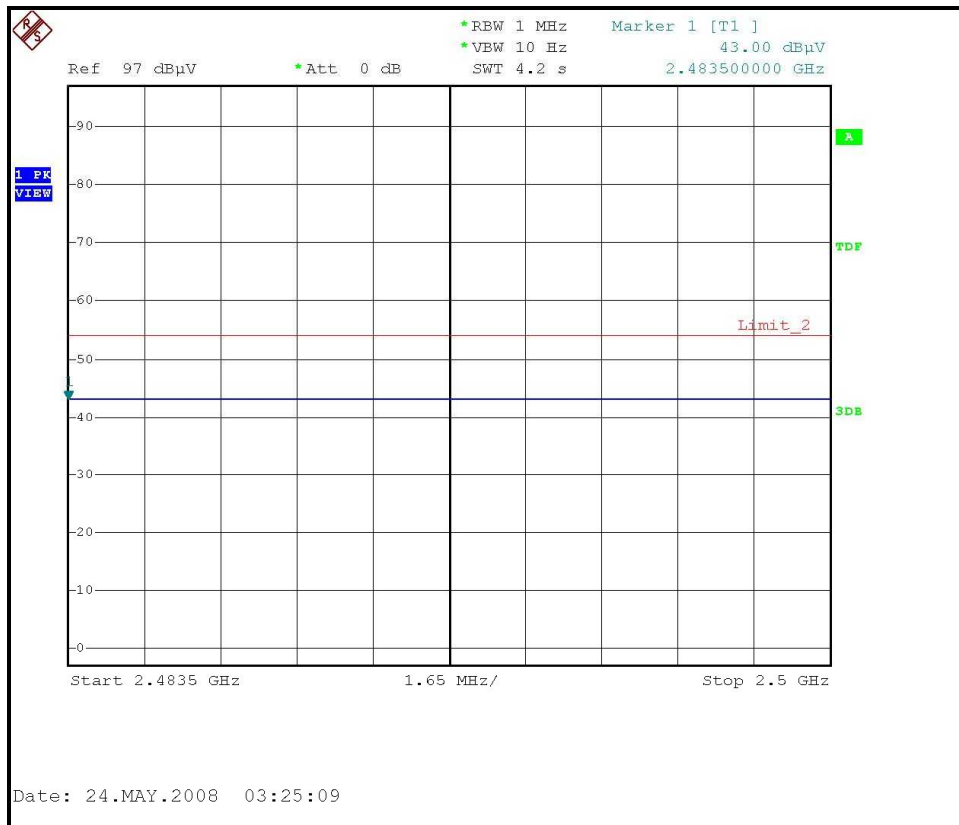
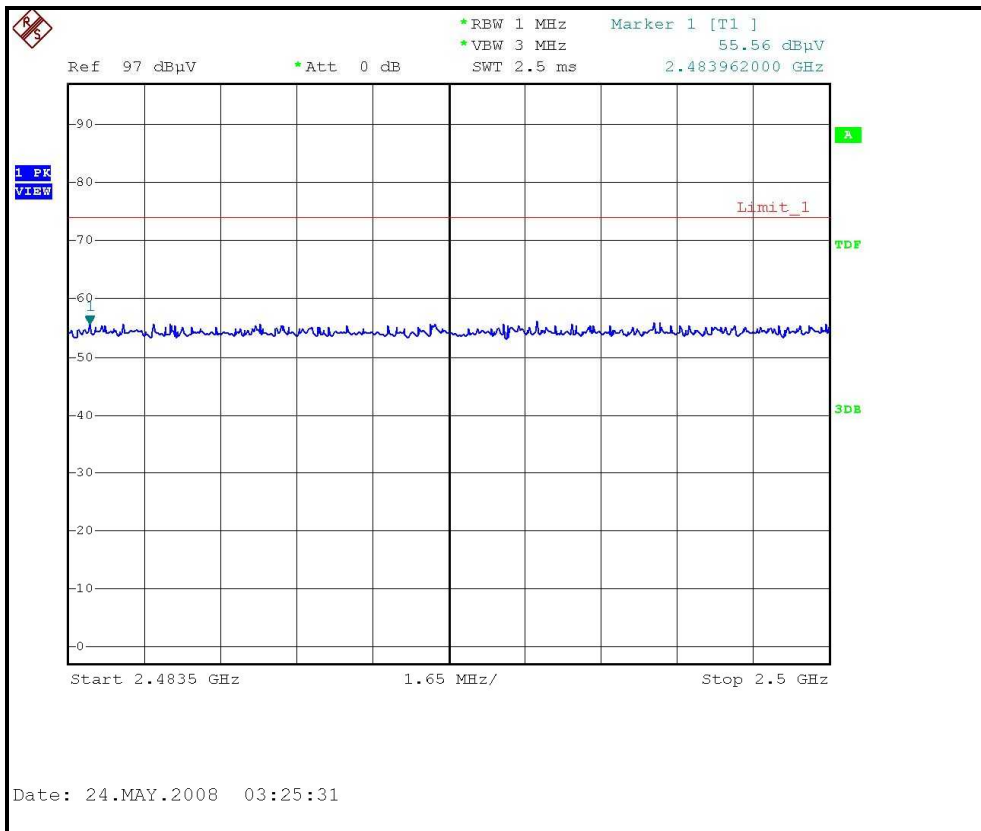

RESTRICTED BANDEDGE (802.11b MODE,CH11, VERTICAL )

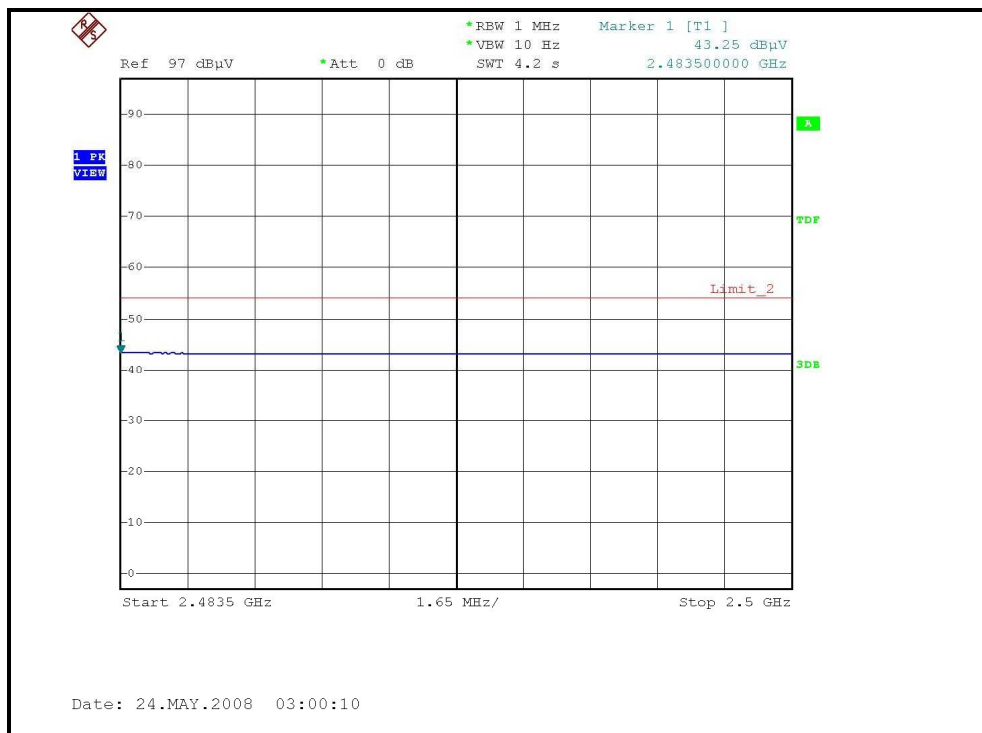
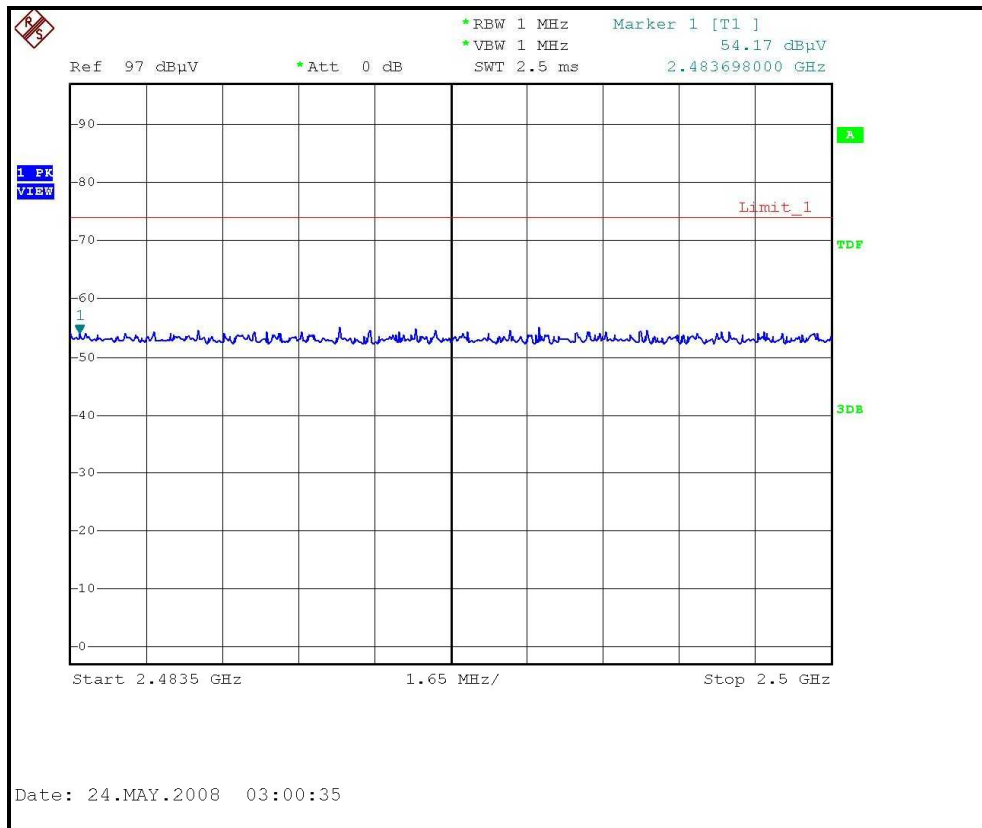

**802.11g OFDM MODULATION – adapter 2 + Dipole antenna**

EUT TEST CONDITION		MEASUREMENT DETAIL	
CHANNEL	Channel 1	FREQUENCY RANGE	1 ~ 25GHz
INPUT POWER (SYSTEM)	120Vac, 60 Hz	DETECTOR FUNCTION	Peak (PK) Average (AV)
ENVIRONMENTAL CONDITIONS	29deg. C, 59%RH 970hPa	TESTED BY	Rex Huang

ANTENNA POLARITY & TEST DISTANCE: HORIZONTAL AT 3 M								
NO.	FREQ. (MHz)	EMISSION LEVEL (dBuV/m)	LIMIT (dBuV/m)	MARGIN (dB)	ANTENNA HEIGHT (m)	TABLE ANGLE (Degree)	RAW VALUE (dBuV)	CORRECTION FACTOR (dB/m)
1	2288.00	46.00 PK	74.00	-28.00	1.00 H	326	16.12	29.88
2	2288.00	40.30 AV	54.00	-13.70	1.00 H	326	10.42	29.88
3	2390.00	54.90 PK	74.00	-19.10	1.45 H	331	24.58	30.32
4	2390.00	43.29 AV	54.00	-10.71	1.45 H	331	12.97	30.32
5	*2412.00	98.20 PK			1.45 H	331	67.79	30.41
6	*2412.00	87.90 AV			1.45 H	331	57.49	30.41
7	4824.00	54.50 PK	74.00	-19.50	1.50 H	188	18.71	35.79
8	4824.00	41.10 AV	54.00	-12.90	1.50 H	188	5.31	35.79
9	7236.00	55.00 PK	78.20	-23.20	1.35 H	60	13.40	41.60
10	7236.00	39.00 AV	67.90	-28.90	1.35 H	60	-2.60	41.60
ANTENNA POLARITY & TEST DISTANCE: VERTICAL AT 3 M								
NO.	FREQ. (MHz)	EMISSION LEVEL (dBuV/m)	LIMIT (dBuV/m)	MARGIN (dB)	ANTENNA HEIGHT (m)	TABLE ANGLE (Degree)	RAW VALUE (dBuV)	CORRECTION FACTOR (dB/m)
1	2288.00	55.30 PK	74.00	-18.70	1.46 V	255	25.42	29.88
2	2288.00	52.70 AV	54.00	-1.30	1.46 V	255	22.82	29.88
3	2390.00	64.38 PK	74.00	-9.62	1.39 V	108	34.06	30.32
4	2390.00	46.30 AV	54.00	-7.70	1.39 V	108	15.98	30.32
5	*2412.00	108.90 PK			1.39 V	108	78.49	30.41
6	*2412.00	98.60 AV			1.39 V	108	68.19	30.41
7	4824.00	56.40 PK	74.00	-17.60	1.47 V	134	20.61	35.79
8	4824.00	43.90 AV	54.00	-10.10	1.47 V	134	8.11	35.79
9	7236.00	61.20 PK	88.90	-27.70	1.17 V	120	19.60	41.60
10	7236.00	41.40 AV	78.60	-37.20	1.17 V	120	-0.20	41.60

- REMARKS:**
1. Emission level (dBuV/m) = Raw Value (dBuV) + Correction Factor (dB/m).
  2. Correction Factor (dB/m) = Antenna Factor (dB/m) + Cable Factor (dB).
  3. The other emission levels were very low against the limit.
  4. Margin value = Emission level – Limit value.
  5. “ \* “: Fundamental frequency.

EUT TEST CONDITION		MEASUREMENT DETAIL	
CHANNEL	Channel 6	FREQUENCY RANGE	1 ~ 25GHz
INPUT POWER (SYSTEM)	120Vac, 60 Hz	DETECTOR FUNCTION	Peak (PK) Average (AV)
ENVIRONMENTAL CONDITIONS	29deg. C, 59%RH 970hPa	TESTED BY	Rex Huang

ANTENNA POLARITY & TEST DISTANCE: HORIZONTAL AT 3 M								
NO.	FREQ. (MHz)	EMISSION LEVEL (dBuV/m)	LIMIT (dBuV/m)	MARGIN (dB)	ANTENNA HEIGHT (m)	TABLE ANGLE (Degree)	RAW VALUE (dBuV)	CORRECTION FACTOR (dB/m)
1	2288.00	46.10 PK	74.00	-27.90	1.00 H	325	16.22	29.88
2	2288.00	40.50 AV	54.00	-13.50	1.00 H	325	10.62	29.88
3	*2437.00	97.50 PK			1.48 H	342	66.98	30.52
4	*2437.00	87.30 AV			1.48 H	342	56.78	30.52
5	4874.00	54.10 PK	74.00	-19.90	1.64 H	178	18.18	35.92
6	4874.00	40.30 AV	54.00	-13.70	1.64 H	178	4.38	35.92
7	7311.00	54.30 PK	74.00	-19.70	1.34 H	53	12.49	41.81
8	7311.00	38.60 AV	54.00	-15.40	1.34 H	53	-3.21	41.81
ANTENNA POLARITY & TEST DISTANCE: VERTICAL AT 3 M								
NO.	FREQ. (MHz)	EMISSION LEVEL (dBuV/m)	LIMIT (dBuV/m)	MARGIN (dB)	ANTENNA HEIGHT (m)	TABLE ANGLE (Degree)	RAW VALUE (dBuV)	CORRECTION FACTOR (dB/m)
1	2288.00	55.20 PK	74.00	-18.80	1.47 V	254	25.32	29.88
2	2288.00	52.80 AV	54.00	-1.20	1.47 V	254	22.92	29.88
3	*2437.00	110.00 PK			1.38 V	109	79.48	30.52
4	*2437.00	98.80 AV			1.38 V	109	68.28	30.52
5	4874.00	53.90 PK	74.00	-20.10	1.26 V	135	17.98	35.92
6	4874.00	41.60 AV	54.00	-12.40	1.26 V	135	5.68	35.92
7	7311.00	60.80 PK	74.00	-13.20	1.15 V	127	18.99	41.81
8	7311.00	41.10 AV	54.00	-12.90	1.15 V	127	-0.71	41.81

- REMARKS:**
1. Emission level (dBuV/m) = Raw Value (dBuV) + Correction Factor (dB/m).
  2. Correction Factor (dB/m) = Antenna Factor (dB/m) + Cable Factor (dB).
  3. The other emission levels were very low against the limit.
  4. Margin value = Emission level – Limit value.
  5. “ \* “: Fundamental frequency.

EUT TEST CONDITION		MEASUREMENT DETAIL	
CHANNEL	Channel 11	FREQUENCY RANGE	1 ~ 25GHz
INPUT POWER (SYSTEM)	120Vac, 60 Hz	DETECTOR FUNCTION	Peak (PK) Average (AV)
ENVIRONMENTAL CONDITIONS	29deg. C, 59%RH 970hPa	TESTED BY	Rex Huang

ANTENNA POLARITY & TEST DISTANCE: HORIZONTAL AT 3 M								
NO.	FREQ. (MHz)	EMISSION LEVEL (dBuV/m)	LIMIT (dBuV/m)	MARGIN (dB)	ANTENNA HEIGHT (m)	TABLE ANGLE (Degree)	RAW VALUE (dBuV)	CORRECTION FACTOR (dB/m)
1	2288.00	46.50 PK	74.00	-27.50	1.00 H	327	16.62	29.88
2	2288.00	40.50 AV	54.00	-13.50	1.00 H	327	10.62	29.88
3	*2462.00	94.40 PK			1.46 H	344	63.77	30.63
4	*2462.00	84.20 AV			1.46 H	344	53.57	30.63
5	2483.50	62.05 PK	74.00	-11.95	1.46 H	344	31.33	30.72
6	2483.50	43.91 AV	54.00	-10.09	1.46 H	344	13.19	30.72
7	4924.00	54.80 PK	74.00	-19.20	1.72 H	174	18.74	36.06
8	4924.00	41.30 AV	54.00	-12.70	1.72 H	174	5.24	36.06
9	7386.00	55.30 PK	74.00	-18.70	1.38 H	45	13.29	42.01
10	7386.00	39.20 AV	54.00	-14.80	1.38 H	45	-2.81	42.01
ANTENNA POLARITY & TEST DISTANCE: VERTICAL AT 3 M								
NO.	FREQ. (MHz)	EMISSION LEVEL (dBuV/m)	LIMIT (dBuV/m)	MARGIN (dB)	ANTENNA HEIGHT (m)	TABLE ANGLE (Degree)	RAW VALUE (dBuV)	CORRECTION FACTOR (dB/m)
1	2288.00	55.30 PK	74.00	-18.70	1.48 V	250	25.42	29.88
2	2288.00	52.80 AV	54.00	-1.20	1.48 V	250	22.92	29.88
3	*2462.00	108.40 PK			1.40 V	110	77.77	30.63
4	*2462.00	97.30 AV			1.40 V	110	66.67	30.63
5	2483.50	72.03 PK	74.00	-1.97	1.40 V	110	41.31	30.72
6	2483.50	49.31 AV	54.00	-4.69	1.40 V	110	18.59	30.72
7	4924.00	53.60 PK	74.00	-20.40	1.23 V	94	17.54	36.06
8	4924.00	40.30 AV	54.00	-13.70	1.23 V	94	4.24	36.06
9	7386.00	60.60 PK	74.00	-13.40	1.17 V	112	18.59	42.01
10	7386.00	41.00 AV	54.00	-13.00	1.17 V	112	-1.01	42.01

- REMARKS:**
1. Emission level (dBuV/m) = Raw Value (dBuV) + Correction Factor (dB/m).
  2. Correction Factor (dB/m) = Antenna Factor (dB/m) + Cable Factor (dB).
  3. The other emission levels were very low against the limit.
  4. Margin value = Emission level – Limit value.
  5. “ \* “: Fundamental frequency.



### RESTRICTED BANDEDGE (802.11g MODE,CH1, HORIZONTAL )

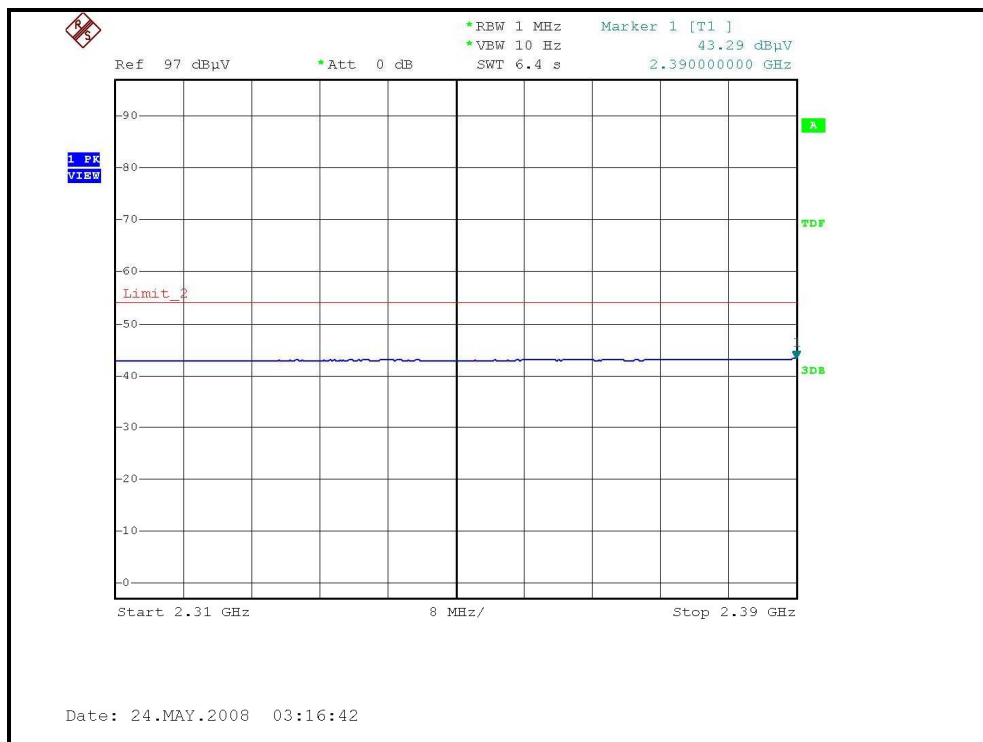
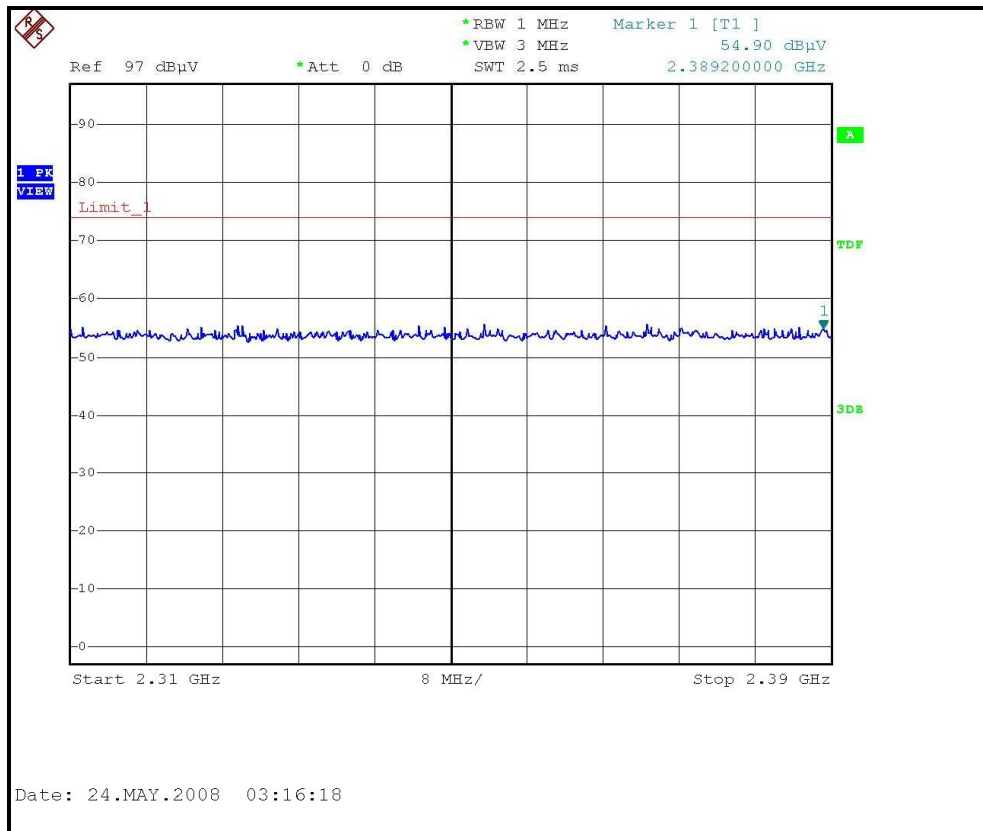

RESTRICTED BANDEDGE (802.11g MODE, CH1, VERTICAL )

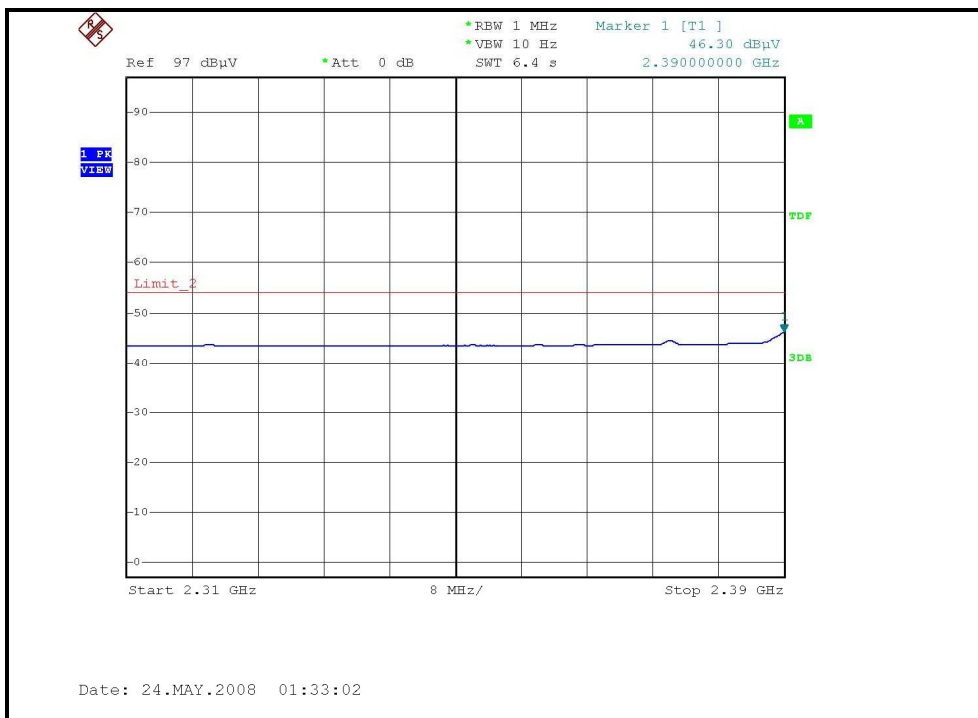
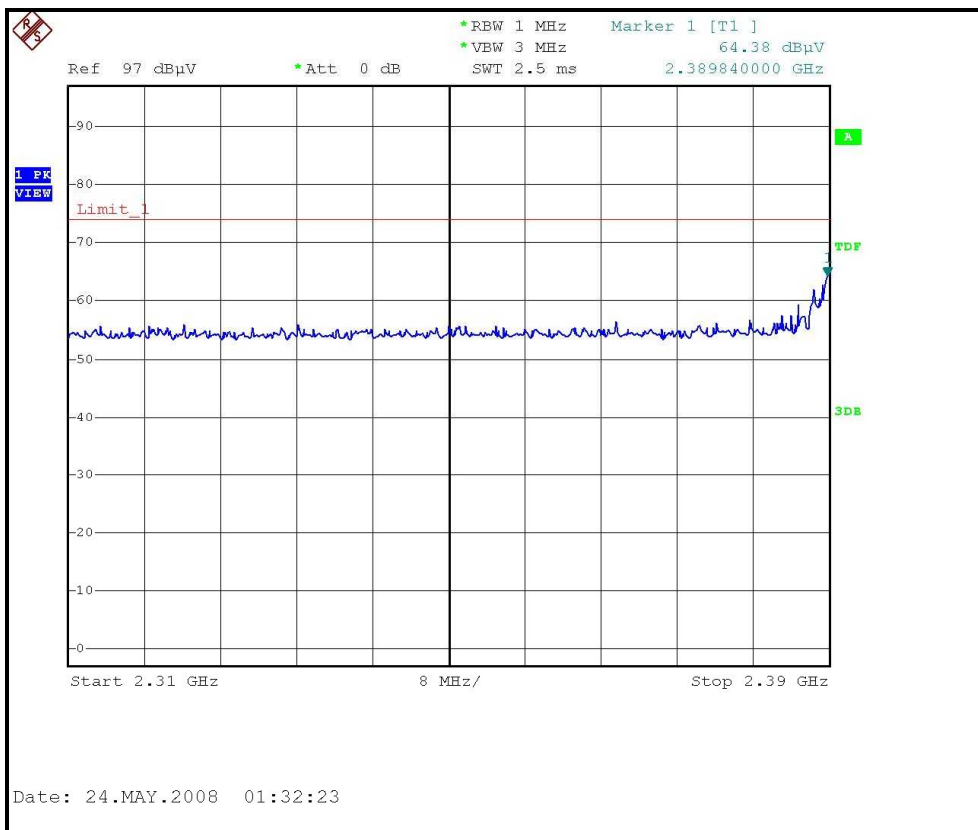

RESTRICTED BANDEDGE (802.11g MODE,CH11, HORIZONTAL )

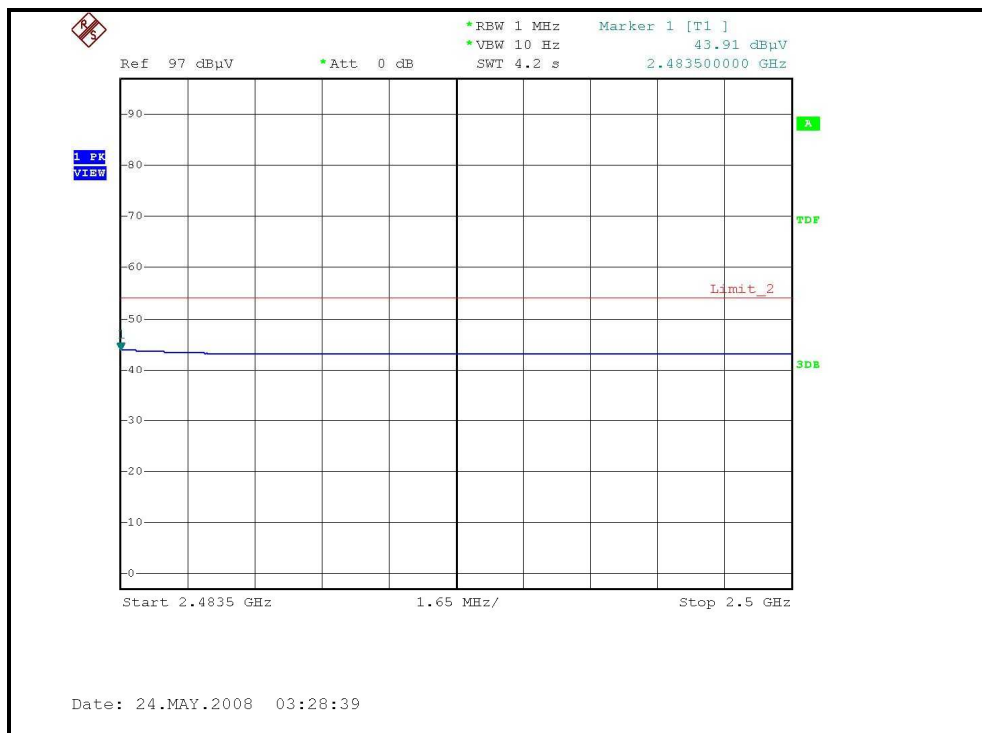
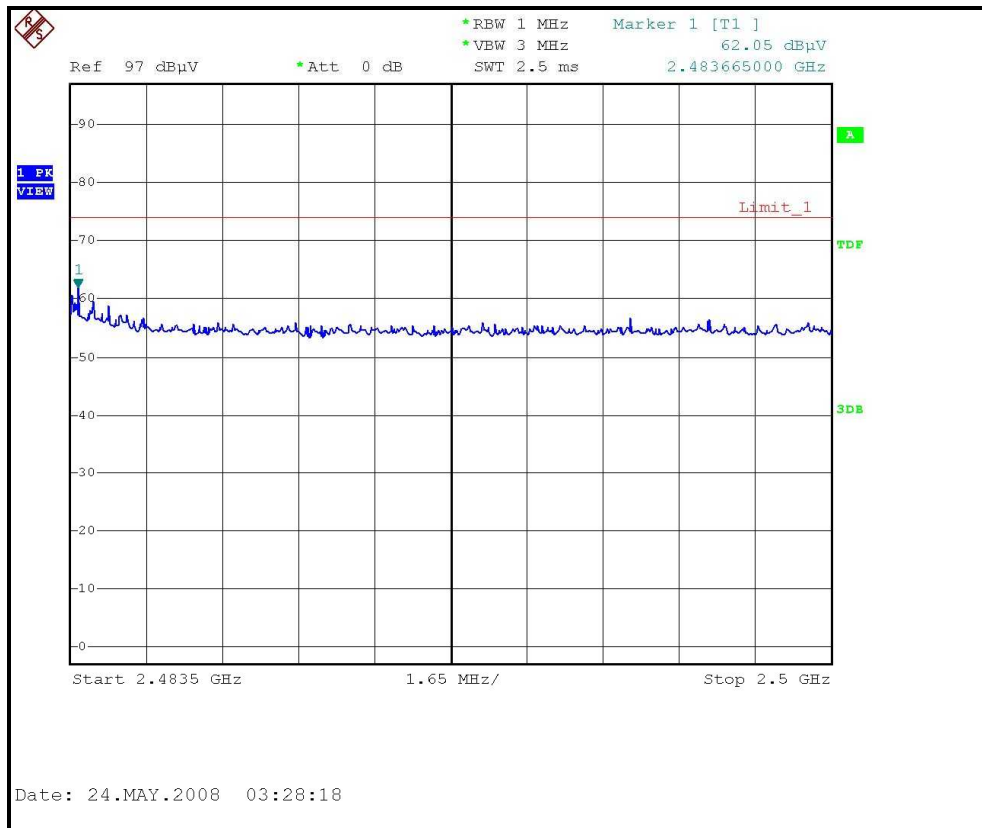

RESTRICTED BANDEDGE (802.11g MODE, CH11, VERTICAL )

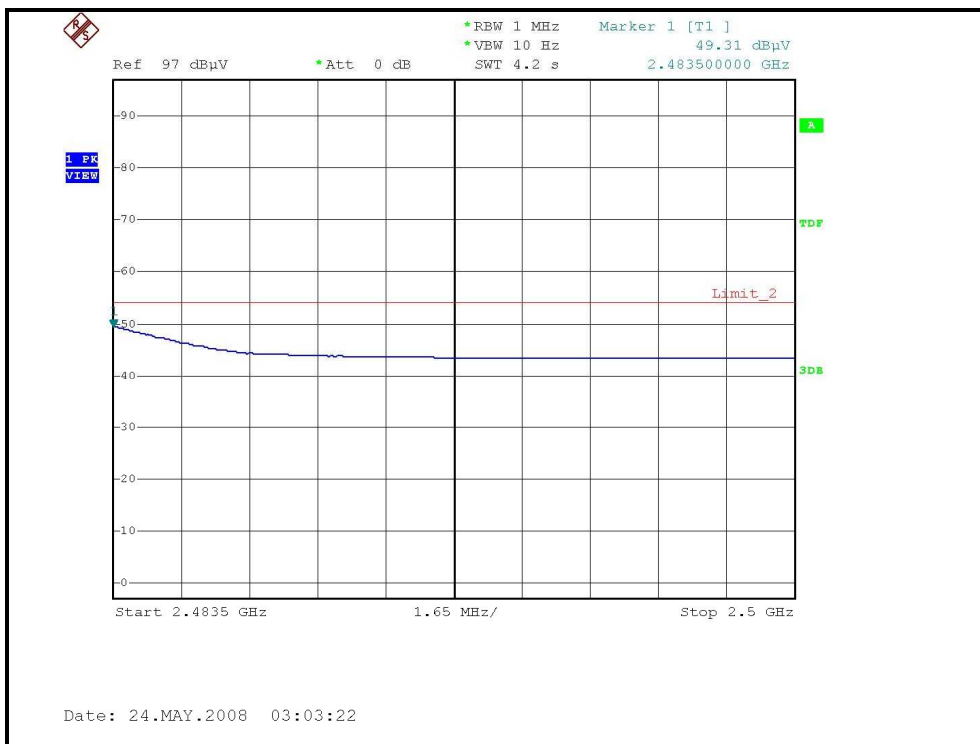
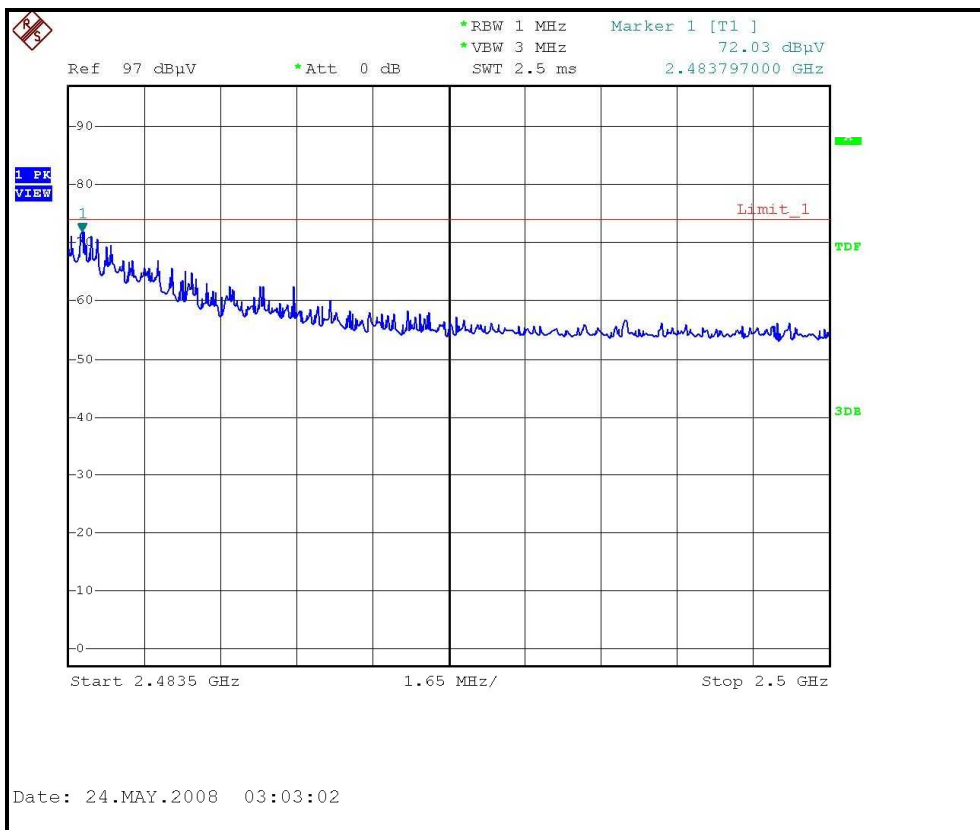

### 802.11b DSSS MODULATION – adapter 2 + Printed antenna

EUT TEST CONDITION		MEASUREMENT DETAIL	
CHANNEL	Channel 1	FREQUENCY RANGE	1 ~ 25GHz
INPUT POWER (SYSTEM)	120Vac, 60 Hz	DETECTOR FUNCTION	Peak (PK) Average (AV)
ENVIRONMENTAL CONDITIONS	29deg. C, 59%RH 970hPa	TESTED BY	Rex Huang

ANTENNA POLARITY & TEST DISTANCE: HORIZONTAL AT 3 M								
NO.	FREQ. (MHz)	EMISSION LEVEL (dBuV/m)	LIMIT (dBuV/m)	MARGIN (dB)	ANTENNA HEIGHT (m)	TABLE ANGLE (Degree)	RAW VALUE (dBuV)	CORRECTION FACTOR (dB/m)
1	2288.00	45.00 PK	74.00	-29.00	1.75 H	328	15.12	29.88
2	2288.00	39.90 AV	54.00	-14.10	1.75 H	328	10.02	29.88
3	2386.00	56.90 PK	74.00	-17.10	1.36 H	346	26.60	30.30
4	2386.00	46.06 AV	54.00	-7.94	1.36 H	346	15.76	30.30
5	*2412.00	98.30 PK			1.36 H	346	67.89	30.41
6	*2412.00	92.60 AV			1.36 H	346	62.19	30.41
7	4824.00	54.73 PK	74.00	-19.27	1.94 H	198	18.94	35.79
8	4824.00	51.60 AV	54.00	-2.40	1.94 H	198	15.81	35.79
9	7236.00	60.00 PK	78.30	-18.30	1.45 H	262	18.40	41.60
10	7236.00	52.80 AV	72.60	-19.80	1.45 H	262	11.20	41.60

ANTENNA POLARITY & TEST DISTANCE: VERTICAL AT 3 M								
NO.	FREQ. (MHz)	EMISSION LEVEL (dBuV/m)	LIMIT (dBuV/m)	MARGIN (dB)	ANTENNA HEIGHT (m)	TABLE ANGLE (Degree)	RAW VALUE (dBuV)	CORRECTION FACTOR (dB/m)
1	2288.00	47.60 PK	74.00	-26.40	1.25 V	17	17.72	29.88
2	2288.00	44.10 AV	54.00	-9.90	1.25 V	17	14.22	29.88
3	2386.00	56.82 PK	74.00	-17.18	1.06 V	39	26.52	30.30
4	2386.00	45.77 AV	54.00	-8.23	1.06 V	39	15.47	30.30
5	*2412.00	99.80 PK			1.06 V	39	69.39	30.41
6	*2412.00	94.00 AV			1.06 V	39	63.59	30.41
7	4824.00	53.60 PK	74.00	-20.40	1.29 V	239	17.81	35.79
8	4824.00	50.20 AV	54.00	-3.80	1.29 V	239	14.41	35.79
9	7236.00	57.90 PK	79.80	-21.90	1.72 V	47	16.30	41.60
10	7236.00	49.90 AV	74.00	-24.10	1.72 V	47	8.30	41.60

- REMARKS:**
1. Emission level (dBuV/m) = Raw Value (dBuV) + Correction Factor (dB/m).
  2. Correction Factor (dB/m) = Antenna Factor (dB/m) + Cable Factor (dB).
  3. The other emission levels were very low against the limit.
  4. Margin value = Emission level – Limit value.
  5. “ \* “: Fundamental frequency.

EUT TEST CONDITION		MEASUREMENT DETAIL	
CHANNEL	Channel 6	FREQUENCY RANGE	1 ~ 25GHz
INPUT POWER (SYSTEM)	120Vac, 60 Hz	DETECTOR FUNCTION	Peak (PK) Average (AV)
ENVIRONMENTAL CONDITIONS	29deg. C, 59%RH 970hPa	TESTED BY	Rex Huang

ANTENNA POLARITY & TEST DISTANCE: HORIZONTAL AT 3 M								
NO.	FREQ. (MHz)	EMISSION LEVEL (dBuV/m)	LIMIT (dBuV/m)	MARGIN (dB)	ANTENNA HEIGHT (m)	TABLE ANGLE (Degree)	RAW VALUE (dBuV)	CORRECTION FACTOR (dB/m)
1	2288.00	56.40 PK	74.00	-17.60	1.34 H	345	26.52	29.88
2	2288.00	45.20 AV	54.00	-8.80	1.34 H	345	15.32	29.88
3	*2437.00	93.20 PK			1.33 H	356	62.68	30.52
4	*2437.00	89.20 AV			1.33 H	356	58.68	30.52
5	4874.00	55.00 PK	74.00	-19.00	1.63 H	206	19.08	35.92
6	4874.00	52.10 AV	54.00	-1.90	1.63 H	206	16.18	35.92
7	7311.00	56.70 PK	74.00	-17.30	1.42 H	273	14.89	41.81
8	7311.00	48.90 AV	54.00	-5.10	1.42 H	273	7.09	41.81
ANTENNA POLARITY & TEST DISTANCE: VERTICAL AT 3 M								
NO.	FREQ. (MHz)	EMISSION LEVEL (dBuV/m)	LIMIT (dBuV/m)	MARGIN (dB)	ANTENNA HEIGHT (m)	TABLE ANGLE (Degree)	RAW VALUE (dBuV)	CORRECTION FACTOR (dB/m)
1	2288.00	46.20 PK	74.00	-27.80	1.04 V	37	16.32	29.88
2	2288.00	42.70 AV	54.00	-11.30	1.04 V	37	12.82	29.88
3	*2437.00	95.90 PK			1.03 V	18	65.38	30.52
4	*2437.00	91.30 AV			1.03 V	18	60.78	30.52
5	4874.00	54.40 PK	74.00	-19.60	1.59 V	226	18.48	35.92
6	4874.00	50.10 AV	54.00	-3.90	1.59 V	226	14.18	35.92
7	7311.00	56.30 PK	74.00	-17.70	1.64 V	52	14.49	41.81
8	7311.00	48.40 AV	54.00	-5.60	1.64 V	52	6.59	41.81

- REMARKS:**
1. Emission level (dBuV/m) = Raw Value (dBuV) + Correction Factor (dB/m).
  2. Correction Factor (dB/m) = Antenna Factor (dB/m) + Cable Factor (dB).
  3. The other emission levels were very low against the limit.
  4. Margin value = Emission level – Limit value.
  5. “ \* “: Fundamental frequency.

EUT TEST CONDITION		MEASUREMENT DETAIL	
CHANNEL	Channel 11	FREQUENCY RANGE	1 ~ 25GHz
INPUT POWER (SYSTEM)	120Vac, 60 Hz	DETECTOR FUNCTION	Peak (PK) Average (AV)
ENVIRONMENTAL CONDITIONS	29deg. C, 59%RH 970hPa	TESTED BY	Rex Huang

ANTENNA POLARITY & TEST DISTANCE: HORIZONTAL AT 3 M								
NO.	FREQ. (MHz)	EMISSION LEVEL (dBuV/m)	LIMIT (dBuV/m)	MARGIN (dB)	ANTENNA HEIGHT (m)	TABLE ANGLE (Degree)	RAW VALUE (dBuV)	CORRECTION FACTOR (dB/m)
1	2288.00	56.50 PK	74.00	-17.50	1.34 H	342	26.62	29.88
2	2288.00	45.10 AV	54.00	-8.90	1.34 H	342	15.22	29.88
3	*2462.00	93.60 PK			1.34 H	346	62.97	30.63
4	*2462.00	89.90 AV			1.34 H	346	59.27	30.63
5	2488.00	56.28 PK	74.00	-17.72	1.34 H	346	25.54	30.74
6	2488.00	43.44 AV	54.00	-10.56	1.34 H	346	12.70	30.74
7	4924.00	55.00 PK	74.00	-19.00	1.78 H	206	18.94	36.06
8	4924.00	52.00 AV	54.00	-2.00	1.78 H	206	15.94	36.06
9	7386.00	55.90 PK	74.00	-18.10	1.43 H	276	13.89	42.01
10	7386.00	48.10 AV	54.00	-5.90	1.43 H	276	6.09	42.01
ANTENNA POLARITY & TEST DISTANCE: VERTICAL AT 3 M								
NO.	FREQ. (MHz)	EMISSION LEVEL (dBuV/m)	LIMIT (dBuV/m)	MARGIN (dB)	ANTENNA HEIGHT (m)	TABLE ANGLE (Degree)	RAW VALUE (dBuV)	CORRECTION FACTOR (dB/m)
1	2288.00	45.90 PK	74.00	-28.10	1.05 V	42	16.02	29.88
2	2288.00	42.40 AV	54.00	-11.60	1.05 V	42	12.52	29.88
3	*2462.00	96.50 PK			1.04 V	87	65.87	30.63
4	*2462.00	91.60 AV			1.04 V	87	60.97	30.63
5	2488.00	57.40 PK	74.00	-16.60	1.04 V	87	26.66	30.74
6	2488.00	45.52 AV	54.00	-8.48	1.04 V	87	14.78	30.74
7	4924.00	53.90 PK	74.00	-20.10	1.52 V	215	17.84	36.06
8	4924.00	49.80 AV	54.00	-4.20	1.52 V	215	13.74	36.06
9	7386.00	55.40 PK	74.00	-18.60	1.61 V	64	13.39	42.01
10	7386.00	47.20 AV	54.00	-6.80	1.61 V	64	5.19	42.01

- REMARKS:**
1. Emission level (dBuV/m) = Raw Value (dBuV) + Correction Factor (dB/m).
  2. Correction Factor (dB/m) = Antenna Factor (dB/m) + Cable Factor (dB).
  3. The other emission levels were very low against the limit.
  4. Margin value = Emission level – Limit value.
  5. “ \* “: Fundamental frequency.

RESTRICTED BANDEDGE (802.11b MODE, CH1, HORIZONTAL )

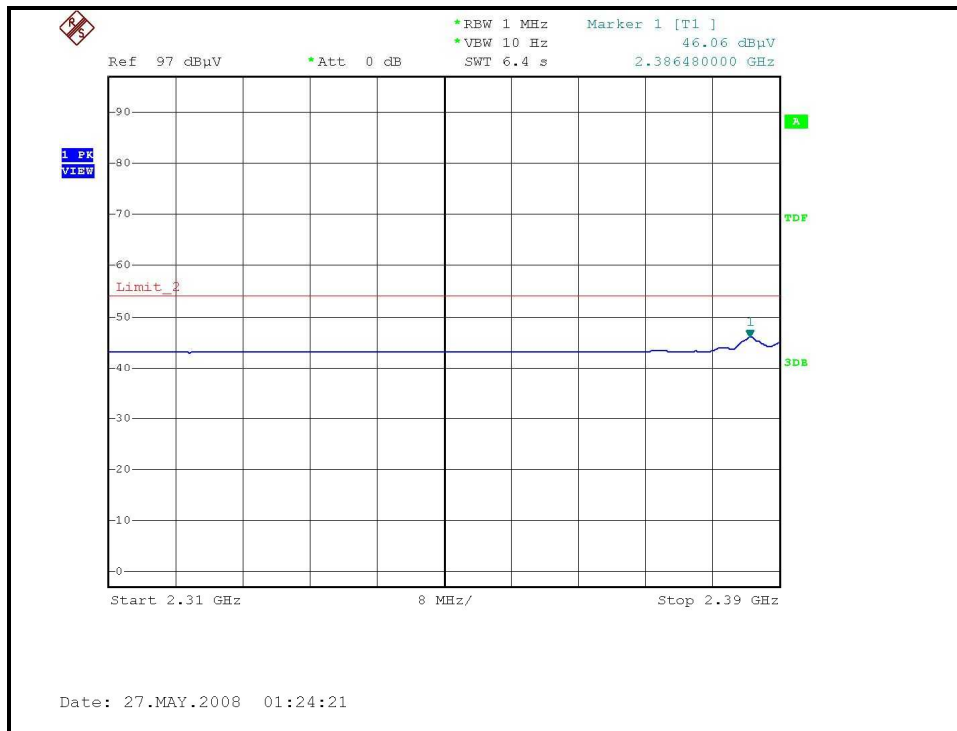
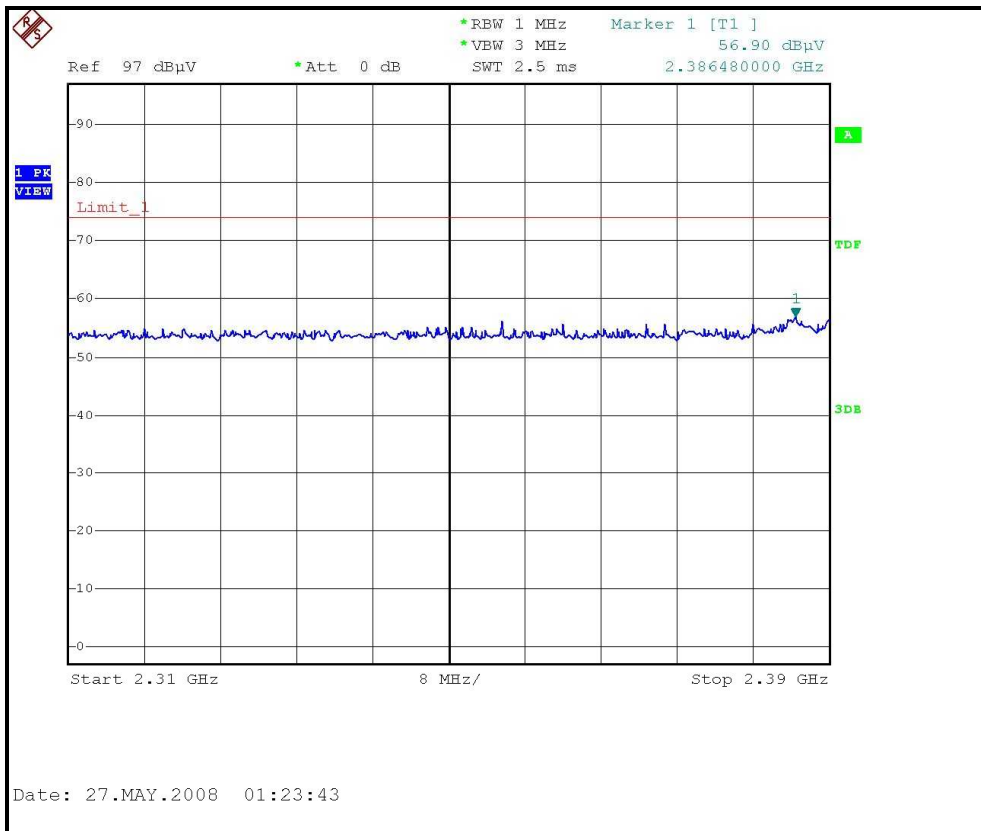



RESTRICTED BANDEDGE (802.11b MODE, CH1, VERTICAL )

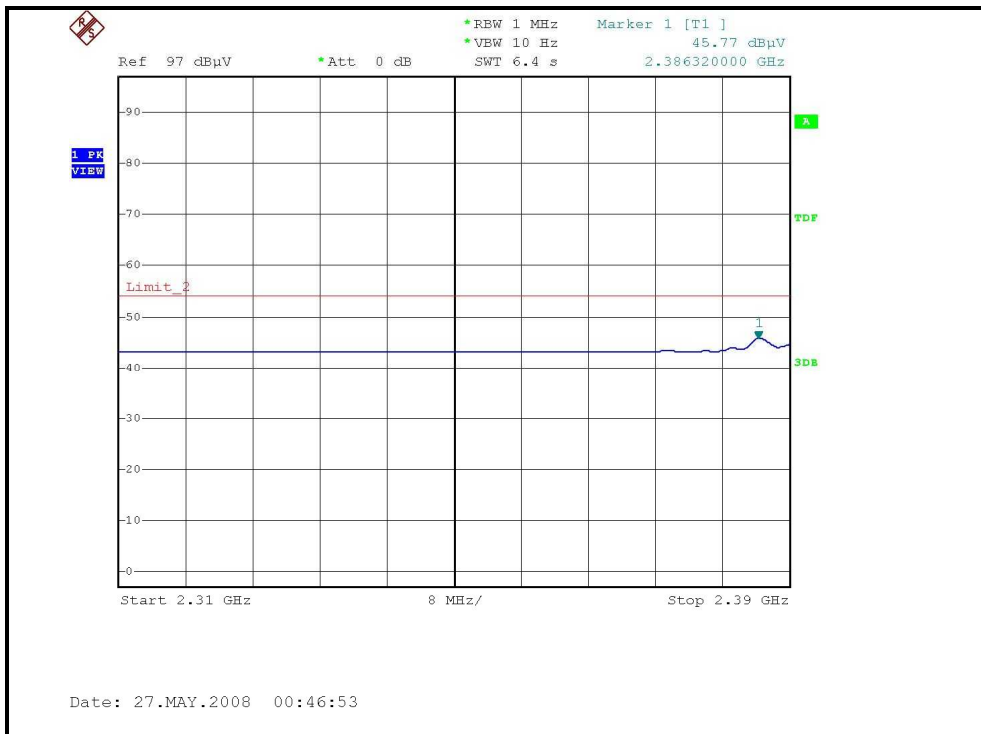
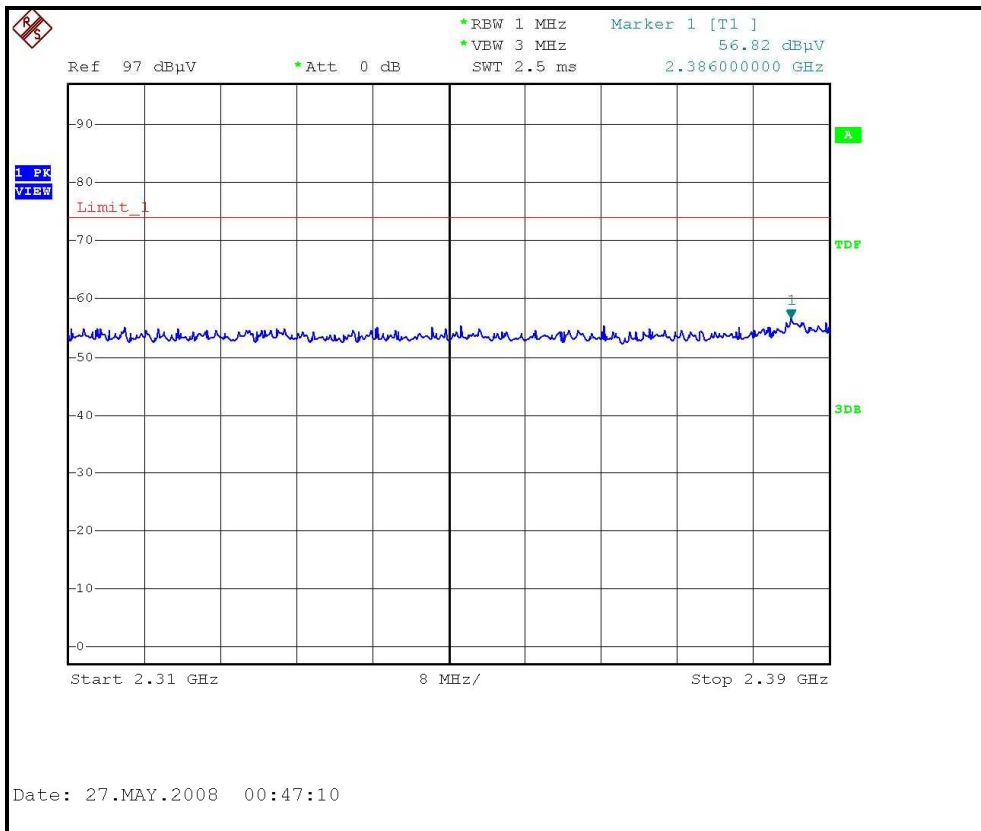

### RESTRICTED BANDEDGE (802.11b MODE,CH11, HORIZONTAL )

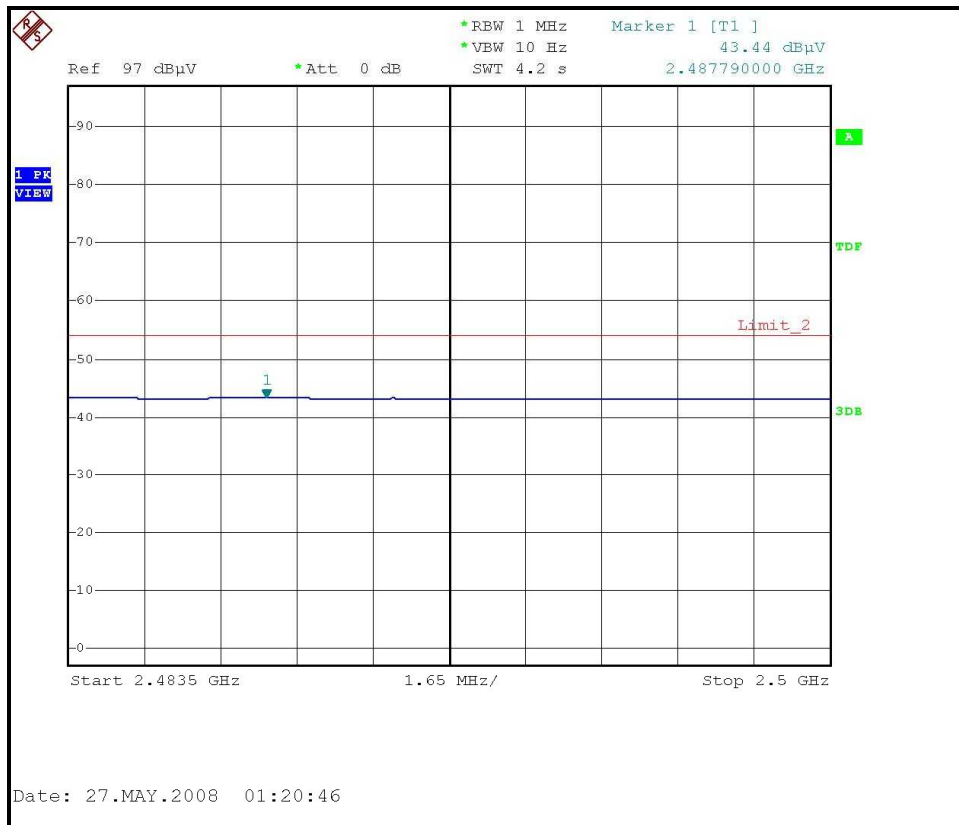
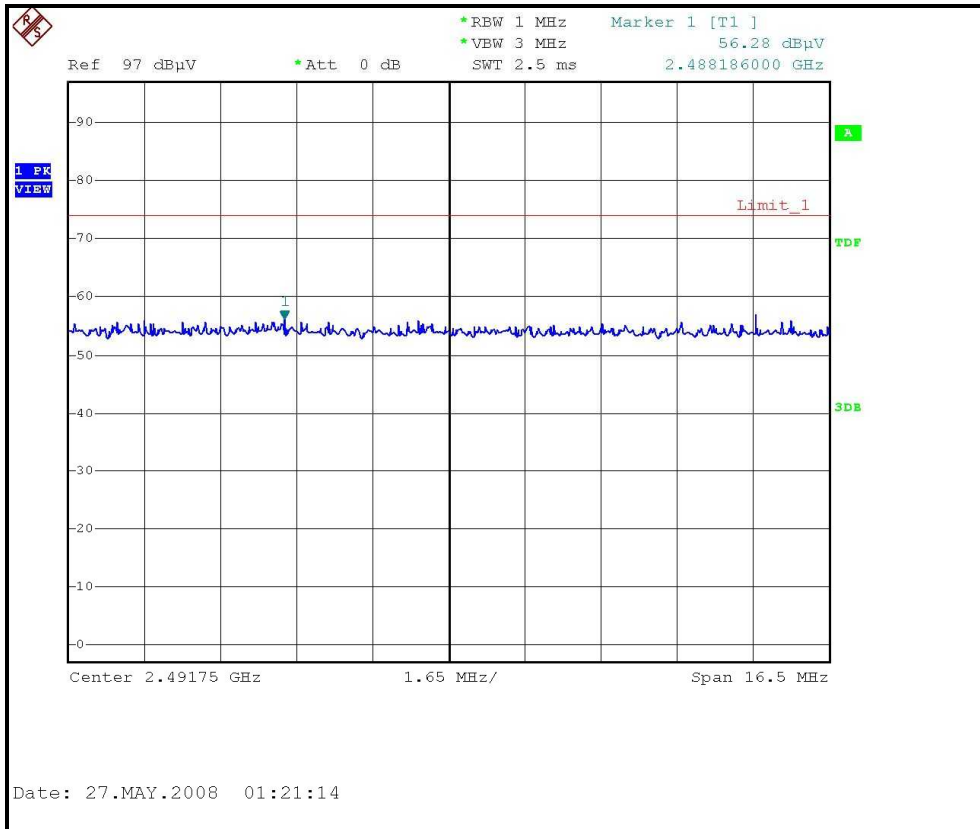

RESTRICTED BANDEDGE (802.11b MODE,CH11, VERTICAL )

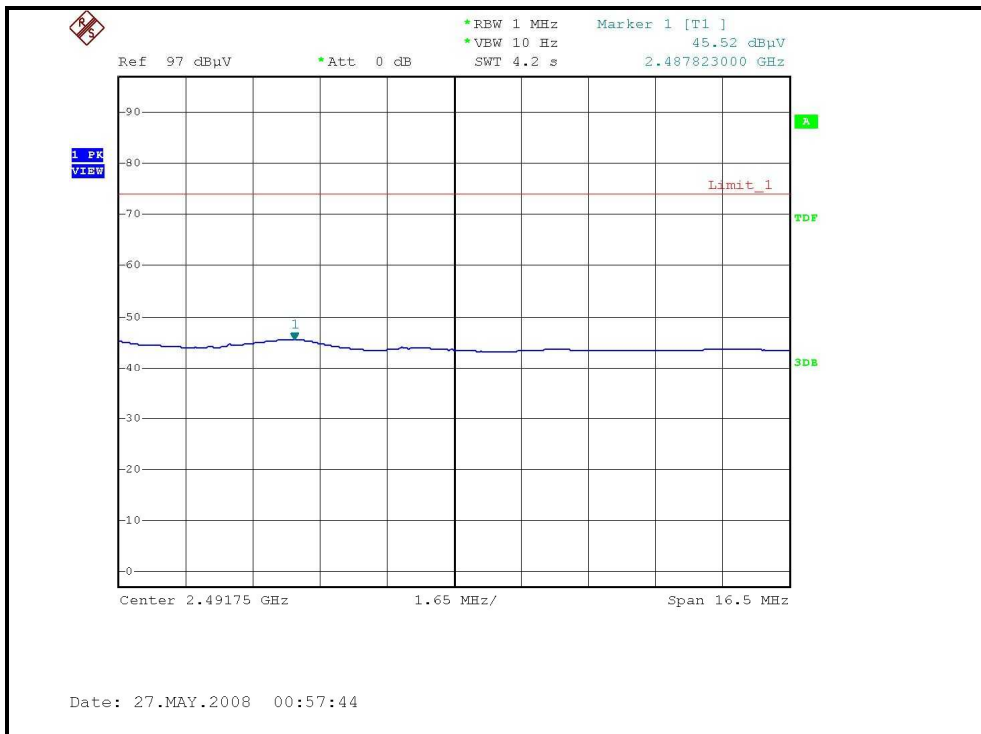
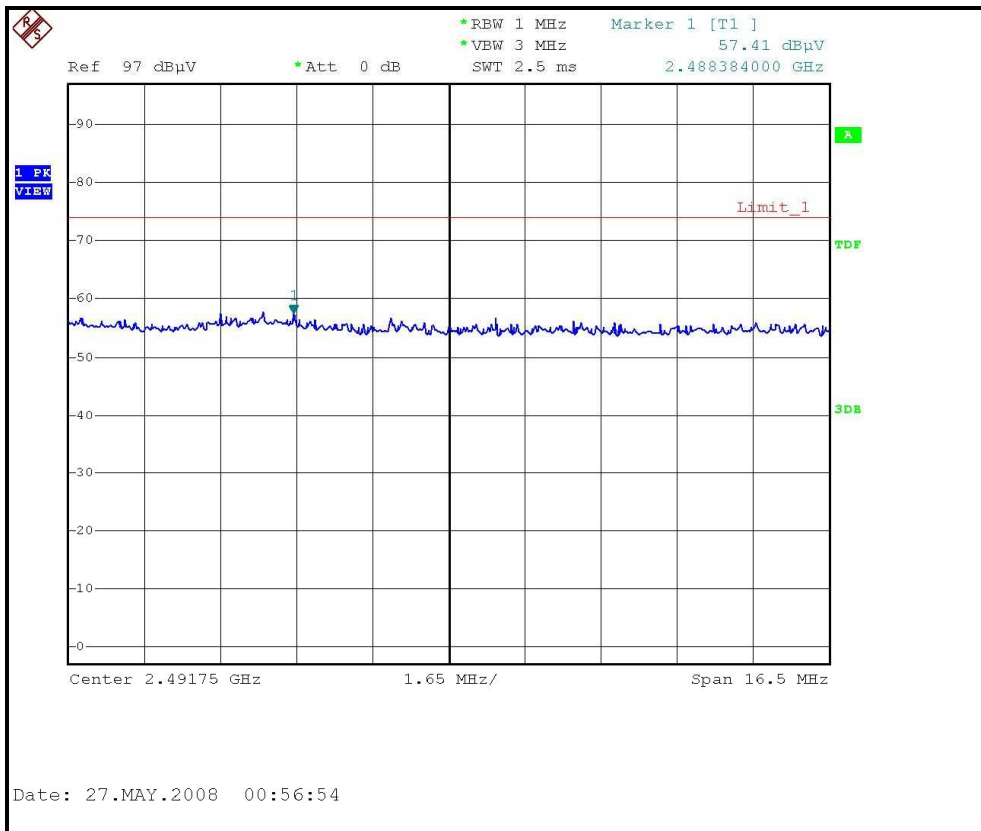

**802.11g OFDM MODULATION – adapter 2 + Printed antenna**

EUT TEST CONDITION		MEASUREMENT DETAIL	
CHANNEL	Channel 1	FREQUENCY RANGE	1 ~ 25GHz
INPUT POWER (SYSTEM)	120Vac, 60 Hz	DETECTOR FUNCTION	Peak (PK) Average (AV)
ENVIRONMENTAL CONDITIONS	29deg. C, 59%RH 970hPa	TESTED BY	Rex Huang

ANTENNA POLARITY & TEST DISTANCE: HORIZONTAL AT 3 M								
NO.	FREQ. (MHz)	EMISSION LEVEL (dBuV/m)	LIMIT (dBuV/m)	MARGIN (dB)	ANTENNA HEIGHT (m)	TABLE ANGLE (Degree)	RAW VALUE (dBuV)	CORRECTION FACTOR (dB/m)
1	2288.00	43.20 PK	74.00	-30.80	1.14 H	4	13.32	29.88
2	2288.00	34.90 AV	54.00	-19.10	1.14 H	4	5.02	29.88
3	2390.00	63.57 PK	74.00	-10.43	1.35 H	350	33.25	30.32
4	2390.00	45.00 AV	54.00	-9.00	1.35 H	350	14.68	30.32
5	*2412.00	96.30 PK			1.35 H	350	65.89	30.41
6	*2412.00	85.69 AV			1.35 H	350	55.28	30.41
7	4824.00	56.80 PK	74.00	-17.20	1.48 H	170	21.01	35.79
8	4824.00	42.50 AV	54.00	-11.50	1.48 H	170	6.71	35.79
9	7236.00	65.10 PK	943.10	-878.00	1.36 H	278	23.50	41.60
10	7236.00	46.40 AV	65.69	-19.29	1.36 H	278	4.80	41.60
ANTENNA POLARITY & TEST DISTANCE: VERTICAL AT 3 M								
NO.	FREQ. (MHz)	EMISSION LEVEL (dBuV/m)	LIMIT (dBuV/m)	MARGIN (dB)	ANTENNA HEIGHT (m)	TABLE ANGLE (Degree)	RAW VALUE (dBuV)	CORRECTION FACTOR (dB/m)
1	2288.00	43.90 PK	74.00	-30.10	1.00 V	66	14.02	29.88
2	2288.00	36.50 AV	54.00	-17.50	1.00 V	66	6.62	29.88
3	2390.00	63.32 PK	74.00	-10.68	1.10 V	22	33.00	30.32
4	2390.00	45.42 AV	54.00	-8.58	1.10 V	22	15.10	30.32
5	*2412.00	97.50 PK			1.10 V	22	67.09	30.41
6	*2412.00	86.40 AV			1.10 V	22	55.99	30.41
7	4824.00	53.70 PK	74.00	-20.30	1.11 V	358	17.91	35.79
8	4824.00	41.00 AV	54.00	-13.00	1.11 V	358	5.21	35.79
9	7236.00	66.20 PK	77.50	-11.30	1.17 V	112	24.60	41.60
10	7236.00	47.10 AV	66.40	-19.30	1.17 V	112	5.50	41.60

- REMARKS:**
1. Emission level (dBuV/m) = Raw Value (dBuV) + Correction Factor (dB/m).
  2. Correction Factor (dB/m) = Antenna Factor (dB/m) + Cable Factor (dB).
  3. The other emission levels were very low against the limit.
  4. Margin value = Emission level – Limit value.
  5. “ \* “: Fundamental frequency.

EUT TEST CONDITION		MEASUREMENT DETAIL	
CHANNEL	Channel 6	FREQUENCY RANGE	1 ~ 25GHz
INPUT POWER (SYSTEM)	120Vac, 60 Hz	DETECTOR FUNCTION	Peak (PK) Average (AV)
ENVIRONMENTAL CONDITIONS	29deg. C, 59%RH 970hPa	TESTED BY	Rex Huang

ANTENNA POLARITY & TEST DISTANCE: HORIZONTAL AT 3 M								
NO.	FREQ. (MHz)	EMISSION LEVEL (dBuV/m)	LIMIT (dBuV/m)	MARGIN (dB)	ANTENNA HEIGHT (m)	TABLE ANGLE (Degree)	RAW VALUE (dBuV)	CORRECTION FACTOR (dB/m)
1	2288.00	43.10 PK	74.00	-30.90	1.14 H	3	13.22	29.88
2	2288.00	34.90 AV	54.00	-19.10	1.14 H	3	5.02	29.88
3	*2437.00	96.80 PK			1.36 H	347	66.28	30.52
4	*2437.00	86.40 AV			1.36 H	347	55.88	30.52
5	4874.00	58.20 PK	74.00	-15.80	1.45 H	179	22.28	35.92
6	4874.00	44.30 AV	54.00	-9.70	1.45 H	179	8.38	35.92
7	7311.00	66.60 PK	74.00	-7.40	1.38 H	275	24.79	41.81
8	7311.00	48.30 AV	54.00	-5.70	1.38 H	275	6.49	41.81
ANTENNA POLARITY & TEST DISTANCE: VERTICAL AT 3 M								
NO.	FREQ. (MHz)	EMISSION LEVEL (dBuV/m)	LIMIT (dBuV/m)	MARGIN (dB)	ANTENNA HEIGHT (m)	TABLE ANGLE (Degree)	RAW VALUE (dBuV)	CORRECTION FACTOR (dB/m)
1	2288.00	43.20 PK	74.00	-30.80	1.00 V	68	13.32	29.88
2	2288.00	36.20 AV	54.00	-17.80	1.00 V	68	6.32	29.88
3	*2437.00	98.10 PK			1.01 V	19	67.58	30.52
4	*2437.00	87.50 AV			1.01 V	19	56.98	30.52
5	4874.00	53.70 PK	74.00	-20.30	1.10 V	246	17.78	35.92
6	4874.00	41.10 AV	54.00	-12.90	1.10 V	246	5.18	35.92
7	7311.00	65.20 PK	74.00	-8.80	1.16 V	110	23.39	41.81
8	7311.00	48.30 AV	54.00	-5.70	1.16 V	110	6.49	41.81

- REMARKS:**
1. Emission level (dBuV/m) = Raw Value (dBuV) + Correction Factor (dB/m).
  2. Correction Factor (dB/m) = Antenna Factor (dB/m) + Cable Factor (dB).
  3. The other emission levels were very low against the limit.
  4. Margin value = Emission level – Limit value.
  5. “ \* “: Fundamental frequency.

EUT TEST CONDITION		MEASUREMENT DETAIL	
CHANNEL	Channel 11	FREQUENCY RANGE	1 ~ 25GHz
INPUT POWER (SYSTEM)	120Vac, 60 Hz	DETECTOR FUNCTION	Peak (PK) Average (AV)
ENVIRONMENTAL CONDITIONS	29deg. C, 59%RH 970hPa	TESTED BY	Rex Huang
TEST MODE	Printed		

ANTENNA POLARITY & TEST DISTANCE: HORIZONTAL AT 3 M								
NO.	FREQ. (MHz)	EMISSION LEVEL (dBuV/m)	LIMIT (dBuV/m)	MARGIN (dB)	ANTENNA HEIGHT (m)	TABLE ANGLE (Degree)	RAW VALUE (dBuV)	CORRECTION FACTOR (dB/m)
1	2288.00	43.00 PK	74.00	-31.00	1.14 H	5	13.12	29.88
2	2288.00	34.80 AV	54.00	-19.20	1.14 H	5	4.92	29.88
3	*2462.00	97.70 PK			1.33 H	347	67.07	30.63
4	*2462.00	87.30 AV			1.33 H	347	56.67	30.63
5	2483.50	66.33 PK	74.00	-7.67	1.33 H	347	35.61	30.72
6	2483.50	46.92 AV	54.00	-7.08	1.33 H	347	16.20	30.72
7	4924.00	67.50 PK	74.00	-6.50	1.42 H	177	31.44	36.06
8	4924.00	49.60 AV	54.00	-4.40	1.42 H	177	13.54	36.06
9	7386.00	67.90 PK	74.00	-6.10	1.32 H	275	25.89	42.01
10	7386.00	52.70 AV	54.00	-1.30	1.32 H	275	10.69	42.01

ANTENNA POLARITY & TEST DISTANCE: VERTICAL AT 3 M								
NO.	FREQ. (MHz)	EMISSION LEVEL (dBuV/m)	LIMIT (dBuV/m)	MARGIN (dB)	ANTENNA HEIGHT (m)	TABLE ANGLE (Degree)	RAW VALUE (dBuV)	CORRECTION FACTOR (dB/m)
1	2288.00	46.70 PK	74.00	-27.30	1.00 V	67	16.82	29.88
2	2288.00	42.70 AV	54.00	-11.30	1.00 V	67	12.82	29.88
3	*2462.00	99.60 PK			1.00 V	19	68.97	30.63
4	*2462.00	89.20 AV			1.00 V	19	58.57	30.63
5	2483.50	68.54 PK	74.00	-5.46	1.00 V	19	37.82	30.72
6	2483.50	48.85 AV	54.00	-5.15	1.00 V	19	18.13	30.72
7	4924.00	66.00 PK	74.00	-8.00	1.13 V	274	29.94	36.06
8	4924.00	49.90 AV	54.00	-4.10	1.13 V	274	13.84	36.06
9	7386.00	68.20 PK	74.00	-5.80	1.13 V	106	26.19	42.01
10	7386.00	52.40 AV	54.00	-1.60	1.13 V	106	10.39	42.01

- REMARKS:**
1. Emission level (dBuV/m) = Raw Value (dBuV) + Correction Factor (dB/m).
  2. Correction Factor (dB/m) = Antenna Factor (dB/m) + Cable Factor (dB).
  3. The other emission levels were very low against the limit.
  4. Margin value = Emission level – Limit value.
  5. “ \* “: Fundamental frequency.

RESTRICTED BANDEDGE (802.11g MODE, CH1, HORIZONTAL )

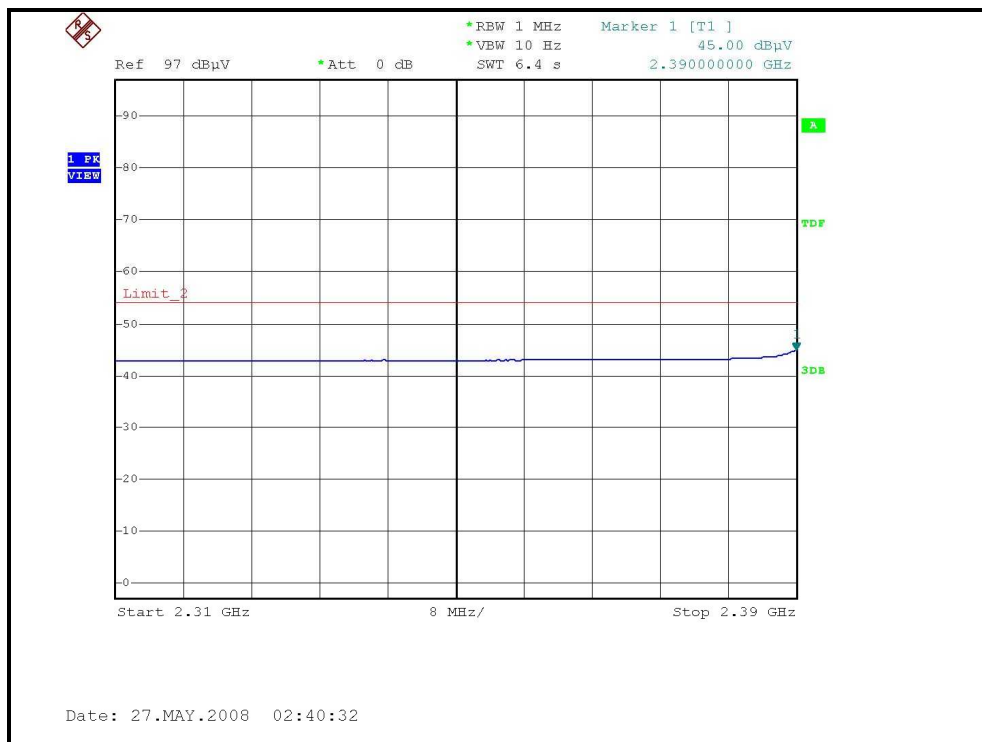
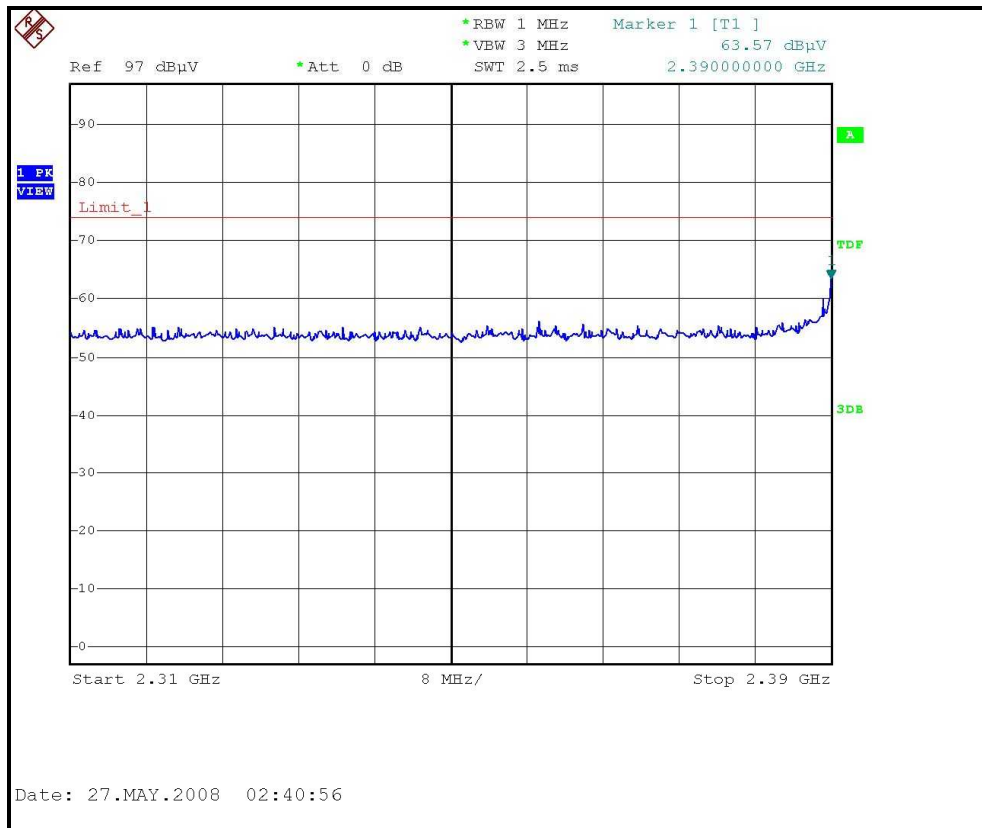



RESTRICTED BANDEDGE (802.11g MODE,CH1, VERTICAL )

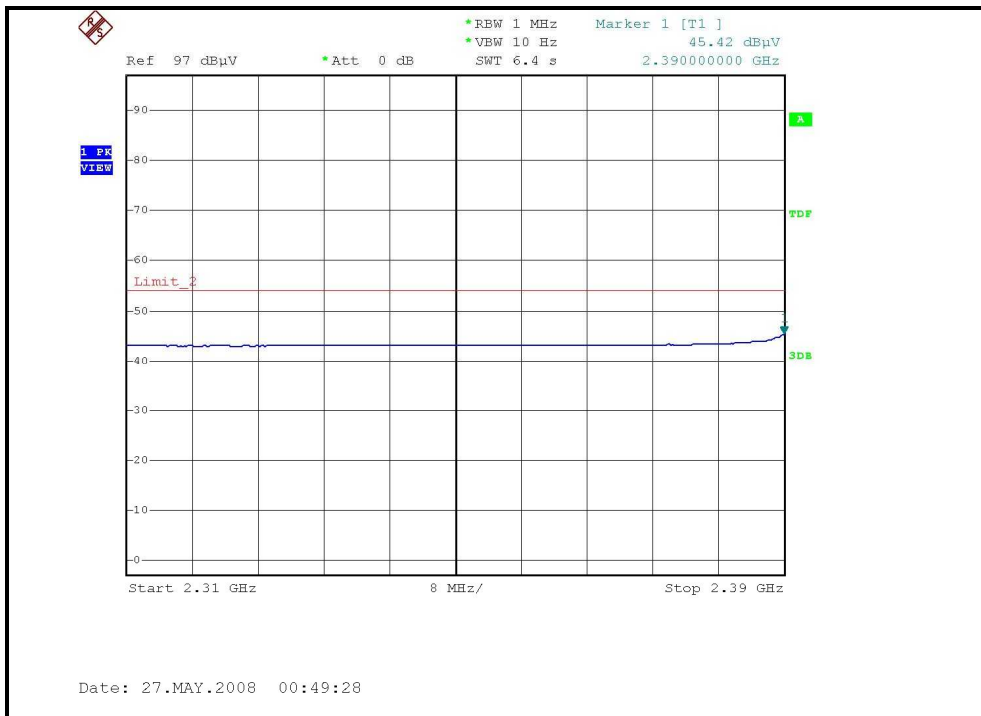
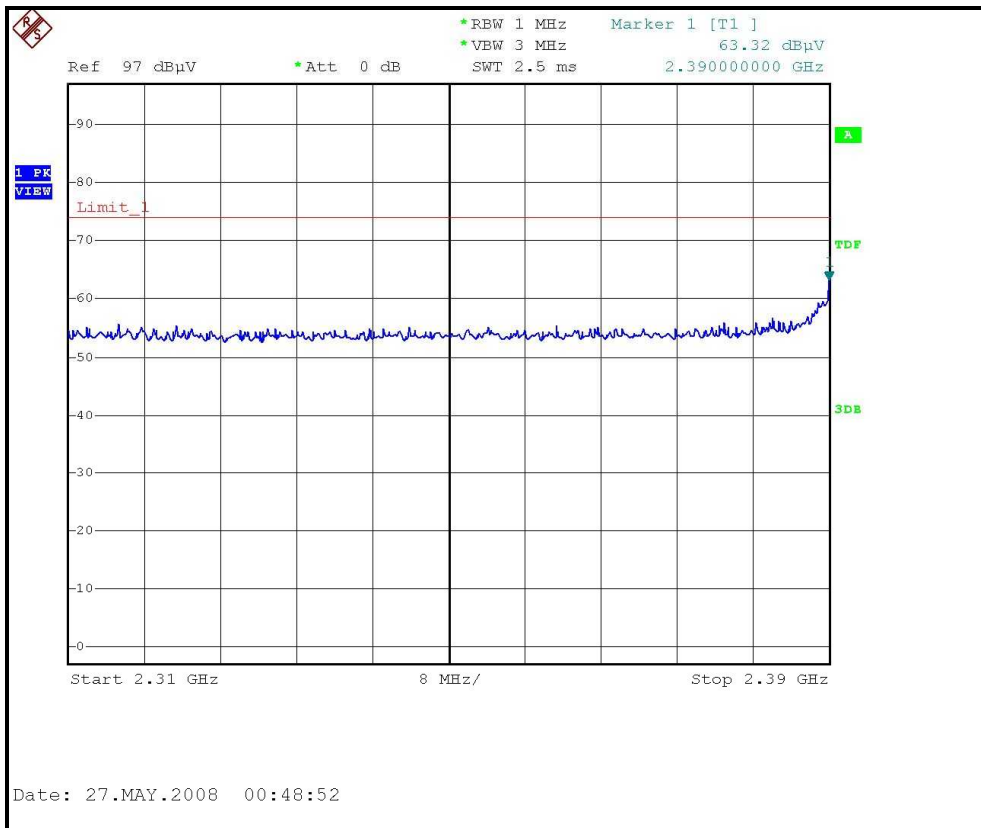



RESTRICTED BANDEDGE (802.11g MODE,CH11, HORIZONTAL )

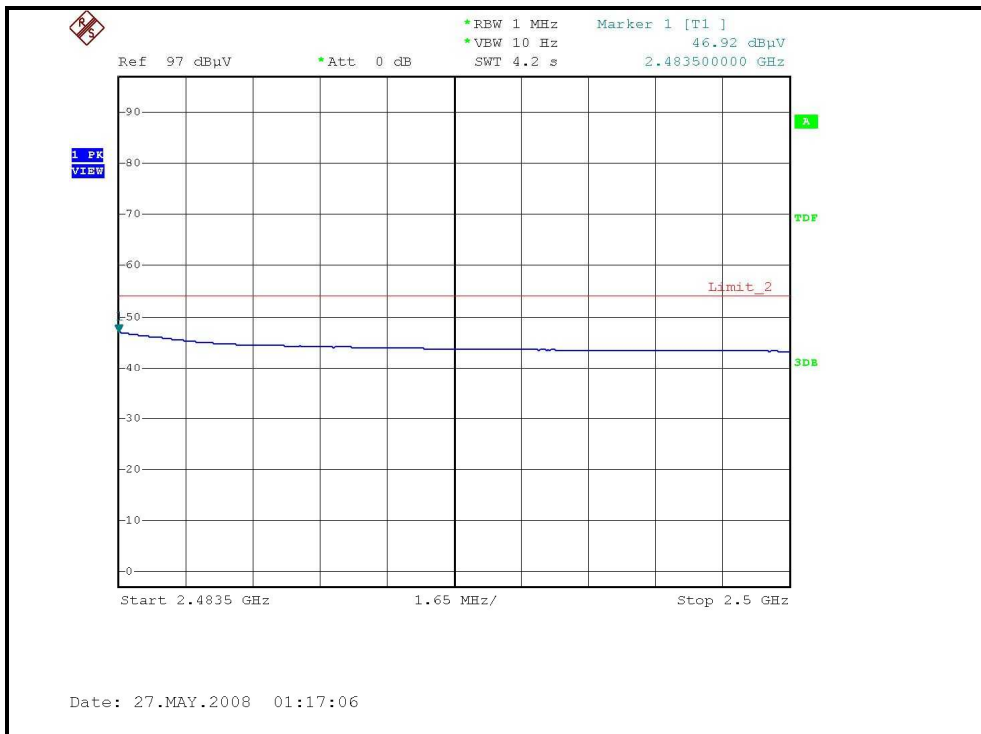
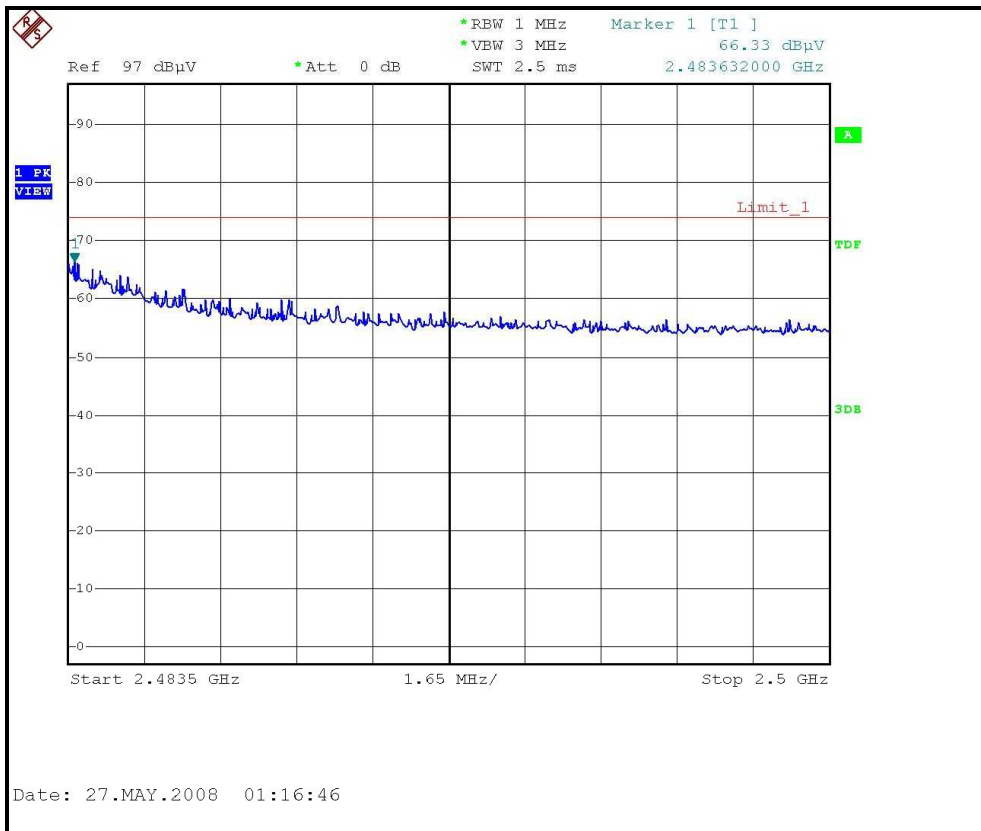

RESTRICTED BANDEDGE (802.11g MODE, CH11, VERTICAL )

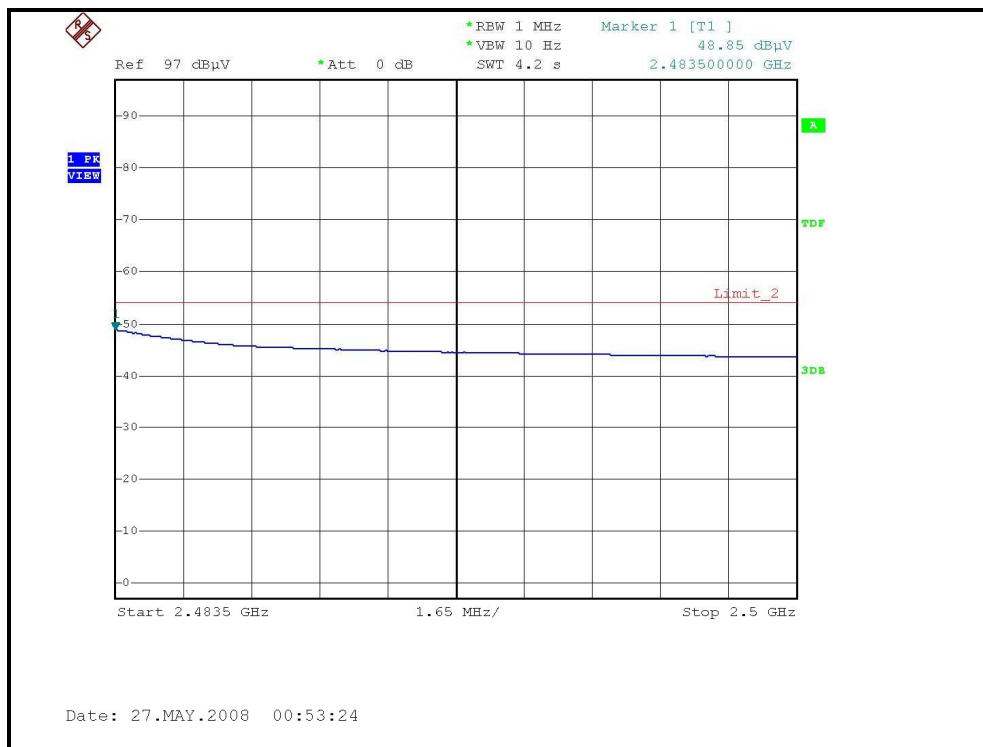
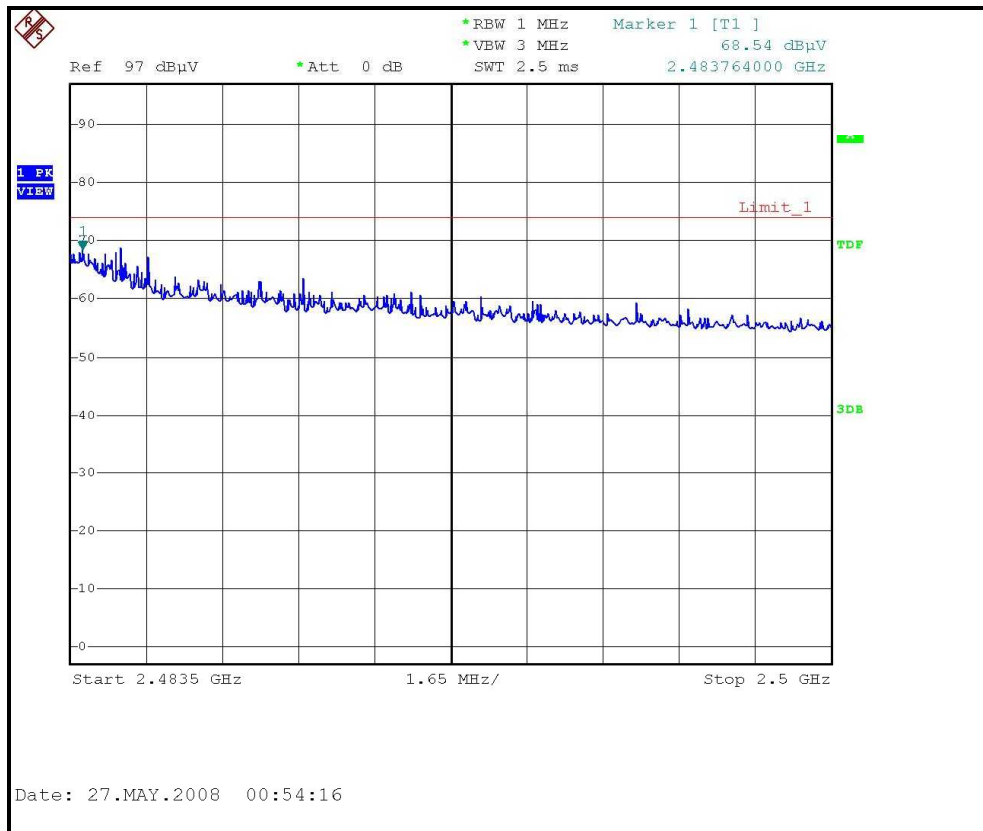

### 4.3 6DB BANDWIDTH MEASUREMENT

#### 4.3.1 LIMITS OF 6dB BANDWIDTH MEASUREMENT

The minimum of 6dB Bandwidth Measurement is 0.5 MHz.

#### 4.3.2 TEST INSTRUMENTS

Description & Manufacturer	Model No.	Serial No.	Calibrated Until
R&S SPECTRUM ANALYZER	FSP40	100037	Dec. 17, 2008

#### NOTE:

- 1.The measurement uncertainty is less than +/- 2.6dB, which is calculated as per the NAMAS document NIS81. This uncertainty represents an expanded uncertainty expressed at approximately the 95% confidence level using a coverage factor of k=2.
- 2.The calibration interval of the above test instruments is 12 months and the calibrations are traceable to NML/ROC and NIST/USA.

#### 4.3.3 TEST PROCEDURE

The transmitter output was connected to the spectrum analyzer through an attenuator. The bandwidth of the fundamental frequency was measured by spectrum analyzer with 100kHz RBW and 100kHz VBW. The 6dB bandwidth is defined as the total spectrum the power of which is higher than peak power minus 6dB.

#### 4.3.4 DEVIATION FROM TEST STANDARD

No deviation

#### 4.3.5 TEST SETUP

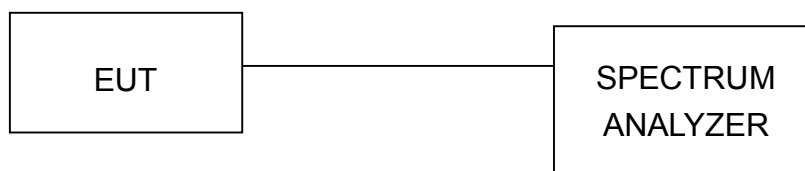

#### 4.3.6 EUT OPERATING CONDITIONS

The software provided by client to enable the EUT under transmission condition continuously at lowest, middle and highest channel frequencies individually.

### 4.3.7 TEST RESULTS

#### 802.11b DSSS MODULATION:

<b>MODULATION TYPE</b>	DBPSK	<b>TRANSFER RATE</b>	1Mbps
<b>INPUT POWER (SYSTEM)</b>	120Vac, 60 Hz	<b>ENVIRONMENTAL CONDITIONS</b>	25deg.C, 60%RH, 970hPa
<b>TESTED BY</b>	Rex Huang		

CHANNEL	CHANNEL FREQUENCY (MHz)	6dB BANDWIDTH (MHz)	MINIMUM LIMIT (MHz)	PASS / FAIL
1	2412	12.08	0.5	PASS
6	2437	12.25	0.5	PASS
11	2462	11.94	0.5	PASS

#### CH1

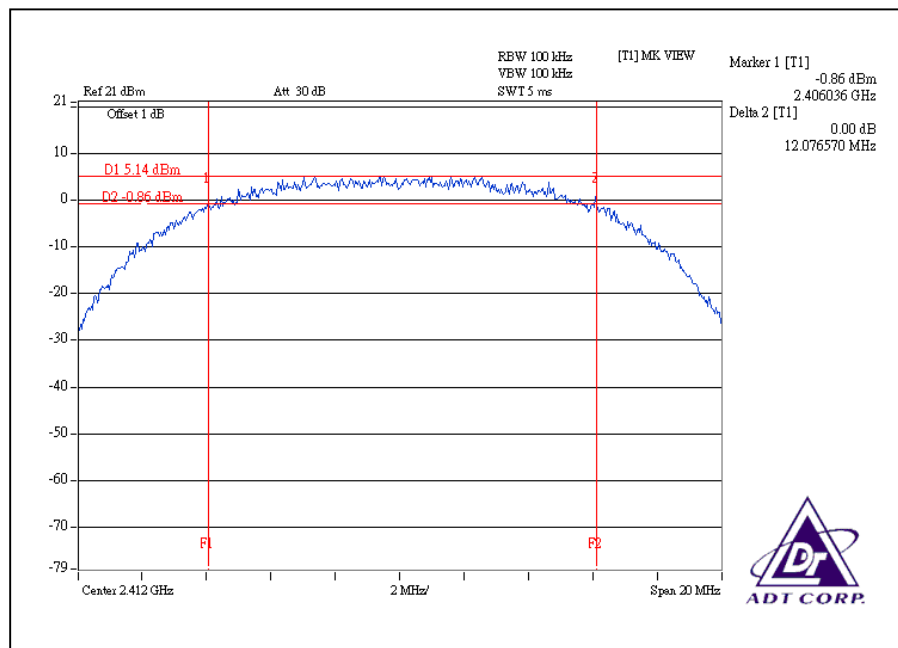

### CH6

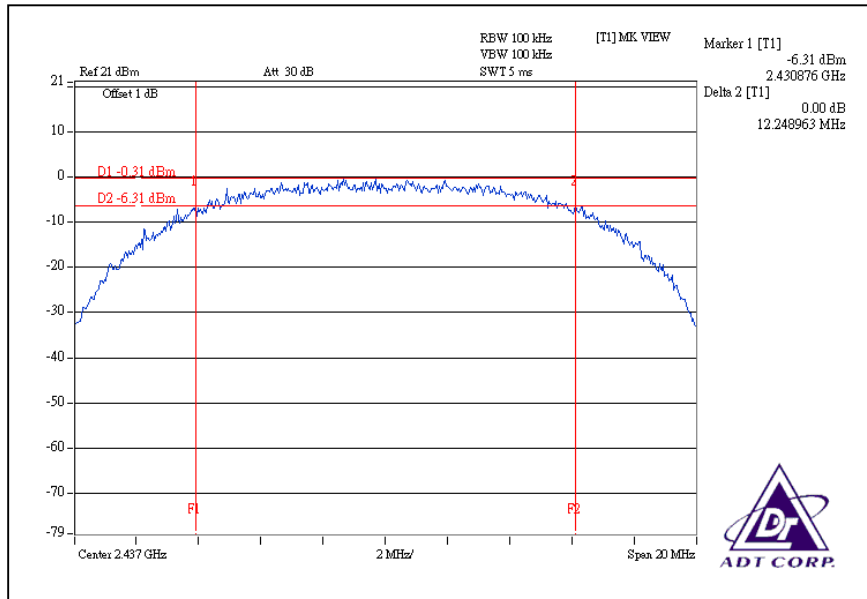

### CH11

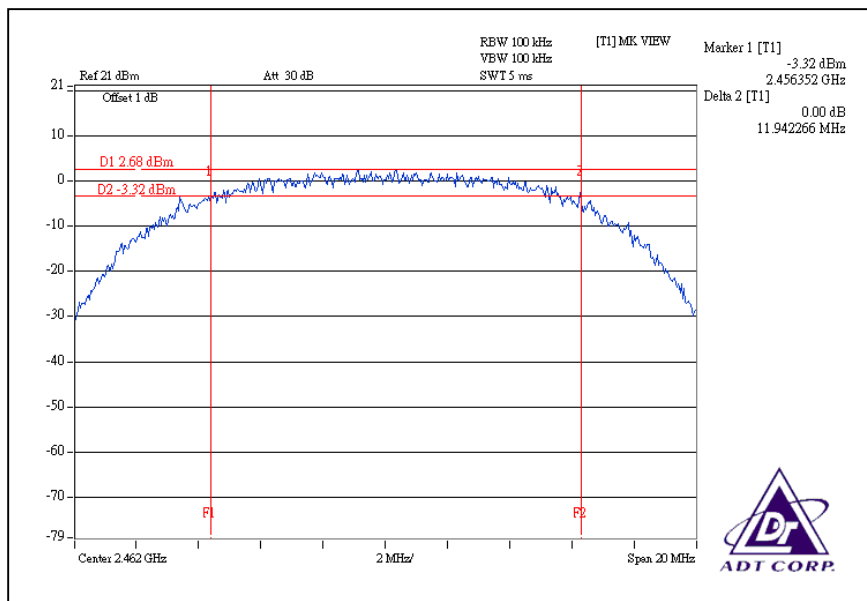

### 802.11g OFDM MODULATION:

<b>MODULATION TYPE</b>	BPSK	<b>TRANSFER RATE</b>	6Mbps
<b>INPUT POWER (SYSTEM)</b>	120Vac, 60 Hz	<b>ENVIRONMENTAL CONDITIONS</b>	25deg.C, 60%RH, 970hPa
<b>TESTED BY</b>	Rex Huang		

CHANNEL	CHANNEL FREQUENCY (MHz)	6dB BANDWIDTH (MHz)	MINIMUM LIMIT (MHz)	PASS / FAIL
1	2412	16.40	0.5	PASS
6	2437	16.39	0.5	PASS
11	2462	16.38	0.5	PASS

CH1

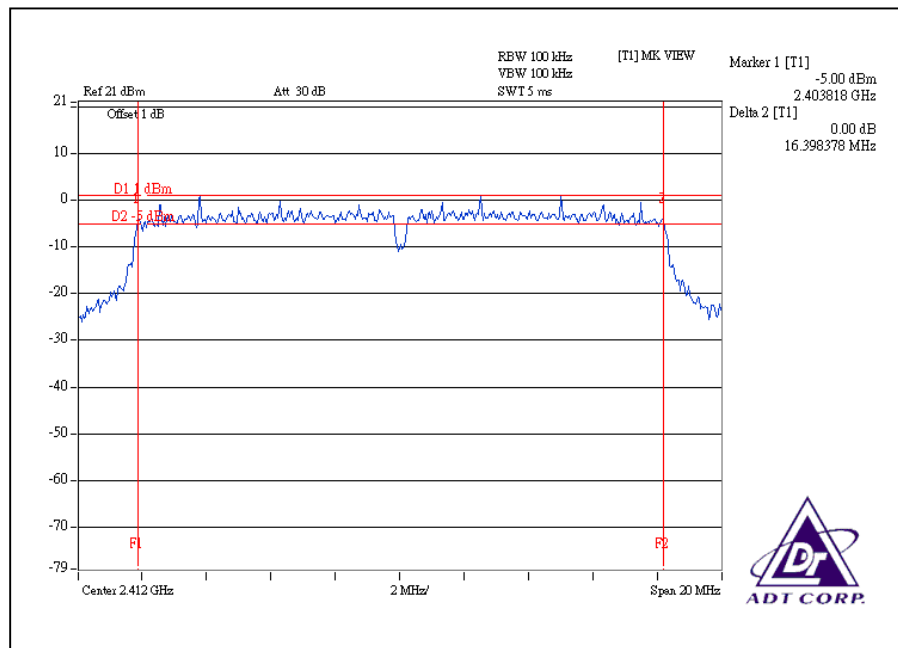

### CH6

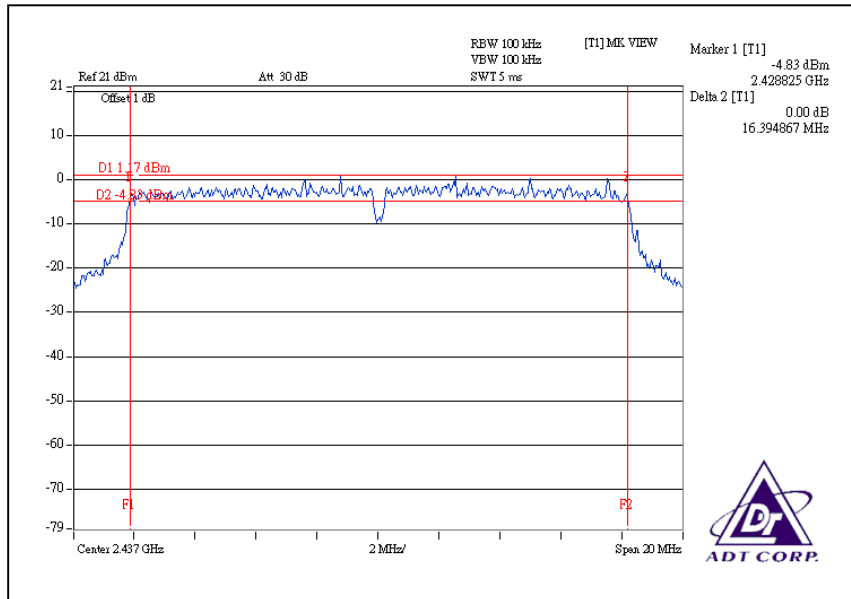

### CH11

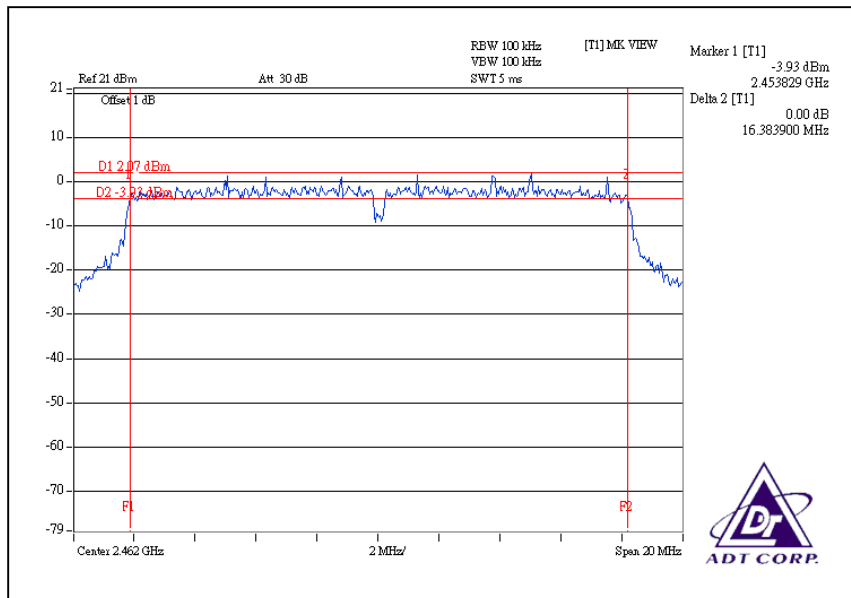

#### 4.4 MAXIMUM PEAK OUTPUT POWER

##### 4.4.1 LIMITS OF MAXIMUM PEAK OUTPUT POWER MEASUREMENT

The Maximum Peak Output Power Measurement is 30dBm.

##### 4.4.2 INSTRUMENTS

Description & Manufacturer	Model No.	Serial No.	Calibrated Until
R&S SPECTRUM ANALYZER	FSP40	100037	Aug. 12, 2008
Agilent SIGNAL GENERATOR	E8257C	MY43320668	Dec. 25, 2008
TEKTRONIX OSCILLOSCOPE	TDS380	B016335	Aug. 15, 2008
NARDA DETECTOR	4503A	FSCM99899	NA

**NOTE:**

The calibration interval of the above test instruments is 12 months and the calibrations are traceable to NML/ROC and NIST/USA.



#### 4.4.3 TEST PROCEDURES

1. A detector was used on the output port of the EUT. An oscilloscope was used to read the response of the detector.
2. Replaced the EUT by the signal generator. The center frequency of the S.G was adjusted to the center frequency of the measured channel.
3. Adjusted the power to have the same reading on oscilloscope. Record the power level.

#### 4.4.4 DEVIATION FROM TEST STANDARD

No deviation

#### 4.4.5 TEST SETUP



#### 4.4.6 EUT OPERATING CONDITIONS

Same as Item 4.3.6

#### 4.4.7 TEST RESULTS

##### 802.11b DSSS MODULATION – Adapter 2 + Dipole antenna:

<b>MODULATION TYPE</b>	DBPSK	<b>TRANSFER RATE</b>	1Mbps
<b>INPUT POWER (SYSTEM)</b>	120Vac, 60 Hz	<b>ENVIRONMENTAL CONDITIONS</b>	25deg.C, 60%RH, 970hPa
<b>TESTED BY</b>	Rex Huang		

CHANNEL	CHANNEL FREQUENCY (MHz)	PEAK POWER OUTPUT (mW)	PEAK POWER OUTPUT (dBm)	PEAK POWER LIMIT (dBm)	PASS / FAIL
1	2412	53.703	17.30	30	PASS
6	2437	18.621	12.70	30	PASS
11	2462	26.915	14.30	30	PASS

##### 802.11g OFDM MODULATION – Adapter 2 + Dipole antenna:

<b>MODULATION TYPE</b>	BPSK	<b>TRANSFER RATE</b>	6Mbps
<b>INPUT POWER (SYSTEM)</b>	120Vac, 60 Hz	<b>ENVIRONMENTAL CONDITIONS</b>	25deg.C, 60%RH, 970hPa
<b>TESTED BY</b>	Rex Huang		

CHANNEL	CHANNEL FREQUENCY (MHz)	PEAK POWER OUTPUT (mW)	PEAK POWER OUTPUT (dBm)	PEAK POWER LIMIT (dBm)	PASS / FAIL
1	2412	53.703	17.30	30	PASS
6	2437	56.234	17.50	30	PASS
11	2462	60.256	17.80	30	PASS



**802.11b DSSS MODULATION – Adapter 2 + Printed antenna:**

<b>MODULATION TYPE</b>	DBPSK	<b>TRANSFER RATE</b>	1Mbps
<b>INPUT POWER (SYSTEM)</b>	120Vac, 60 Hz	<b>ENVIRONMENTAL CONDITIONS</b>	25deg.C, 60%RH, 970hPa
<b>TESTED BY</b>	Rex Huang		

CHANNEL	CHANNEL FREQUENCY (MHz)	PEAK POWER OUTPUT (mW)	PEAK POWER OUTPUT (dBm)	PEAK POWER LIMIT (dBm)	PASS / FAIL
1	2412	53.703	17.30	30	PASS
6	2437	18.621	12.70	30	PASS
11	2462	26.915	14.30	30	PASS

**802.11g OFDM MODULATION – Adapter 2 + Printed antenna:**

<b>MODULATION TYPE</b>	BPSK	<b>TRANSFER RATE</b>	6Mbps
<b>INPUT POWER (SYSTEM)</b>	120Vac, 60 Hz	<b>ENVIRONMENTAL CONDITIONS</b>	25deg.C, 60%RH, 970hPa
<b>TESTED BY</b>	Rex Huang		

CHANNEL	CHANNEL FREQUENCY (MHz)	PEAK POWER OUTPUT (mW)	PEAK POWER OUTPUT (dBm)	PEAK POWER LIMIT (dBm)	PASS / FAIL
1	2412	53.703	17.30	30	PASS
6	2437	56.234	17.50	30	PASS
11	2462	60.256	17.80	30	PASS



## 4.5 POWER SPECTRAL DENSITY MEASUREMENT

### 4.5.1 LIMITS OF POWER SPECTRAL DENSITY MEASUREMENT

The Maximum of Power Spectral Density Measurement is 8dBm.

### 4.5.2 TEST INSTRUMENTS

Description & Manufacturer	Model No.	Serial No.	Calibrated Until
R&S SPECTRUM ANALYZER	FSP40	100037	Sep. 06, 2008

**NOTE:**

- 1.The measurement uncertainty is less than +/- 2.6dB, which is calculated as per the NAMAS document NIS81. This uncertainty represents an expanded uncertainty expressed at approximately the 95% confidence level using a coverage factor of k=2.
- 2.The calibration interval of the above test instruments is 12 months and the calibrations are traceable to NML/ROC and NIST/USA.

#### 4.5.3 TEST PROCEDURE

The transmitter output was connected to the spectrum analyzer through an attenuator, the bandwidth of the fundamental frequency was measured with the spectrum analyzer using 3kHz RBW and 30kHz VBW, set sweep time = span/3kHz. The power spectral density was measured and recorded. The sweep time is allowed to be longer than span/3kHz for a full response of the mixer in the spectrum analyzer.

#### 4.5.4 DEVIATION FROM TEST STANDARD

No deviation

#### 4.5.5 TEST SETUP

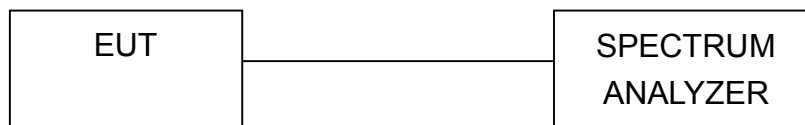

#### 4.5.6 EUT OPERATING CONDITION

Same as Item 4.3.6

## 4.5.7 TEST RESULTS

### 802.11b DSSS MODULATION:

<b>MODULATION TYPE</b>	DBPSK	<b>TRANSFER RATE</b>	1Mbps
<b>INPUT POWER (SYSTEM)</b>	120Vac, 60 Hz	<b>ENVIRONMENTAL CONDITIONS</b>	25deg.C, 60%RH, 970hPa
<b>TESTED BY</b>	Rex Huang		

CHANNEL	CHANNEL FREQUENCY (MHz )	RF POWER LEVEL IN 3kHz BW (dBm)	MAXIMUM LIMIT (dBm)	PASS / FAIL
1	2412	-8.76	8	PASS
6	2437	-15.10	8	PASS
11	2462	-11.41	8	PASS

CH1

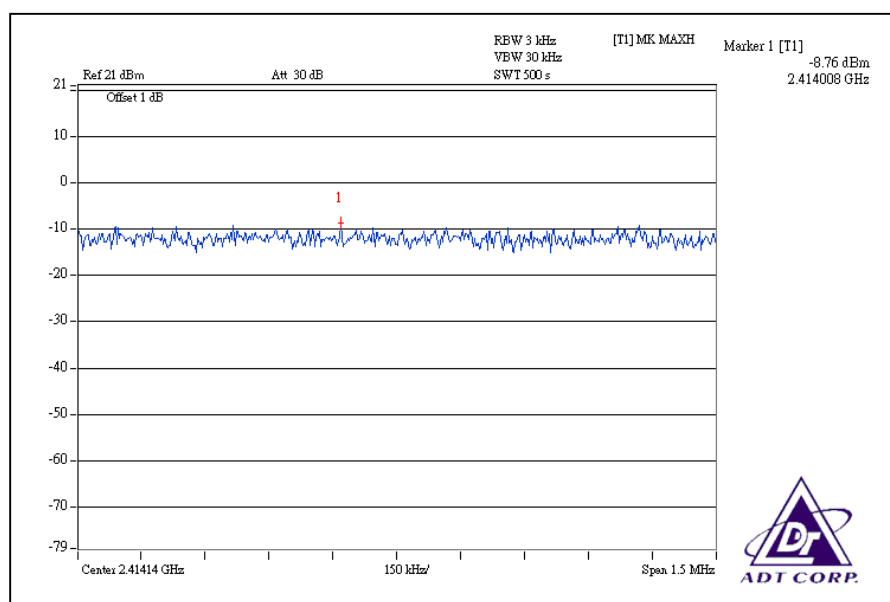

### CH6

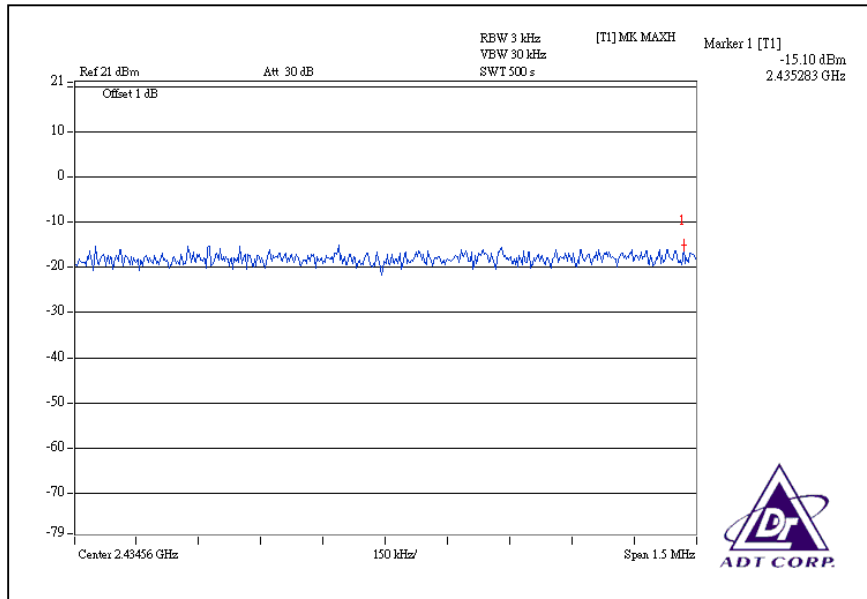

### CH11

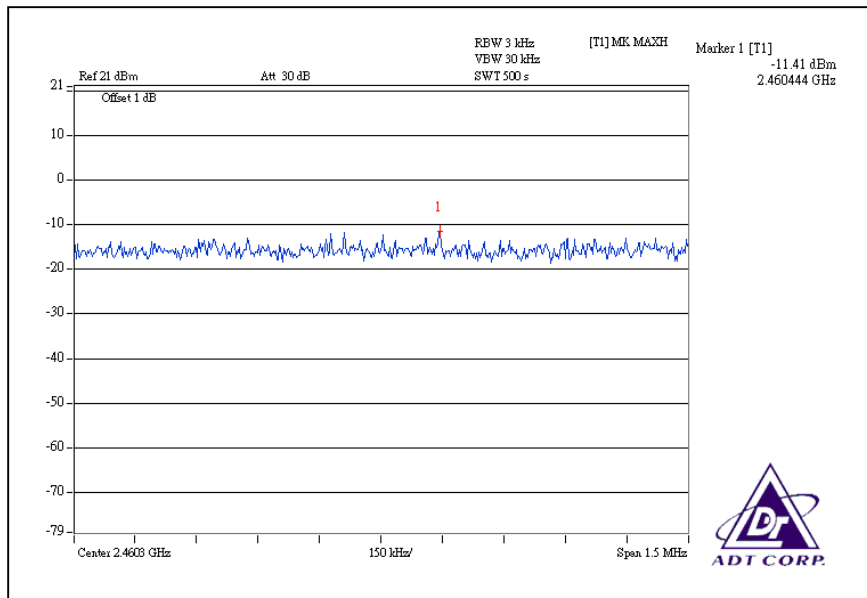

### 802.11g OFDM MODULATION:

<b>MODULATION TYPE</b>	BPSK	<b>TRANSFER RATE</b>	6Mbps
<b>INPUT POWER (SYSTEM)</b>	120Vac, 60 Hz	<b>ENVIRONMENTAL CONDITIONS</b>	25deg.C, 60%RH, 970hPa
<b>TESTED BY</b>	Rex Huang		

CHANNEL	CHANNEL FREQUENCY (MHz)	RF POWER LEVEL IN 3kHz BW (dBm)	MAXIMUM LIMIT (dBm)	PASS / FAIL
1	2412	-12.60	8	PASS
6	2437	-12.44	8	PASS
11	2462	-12.67	8	PASS

CH1

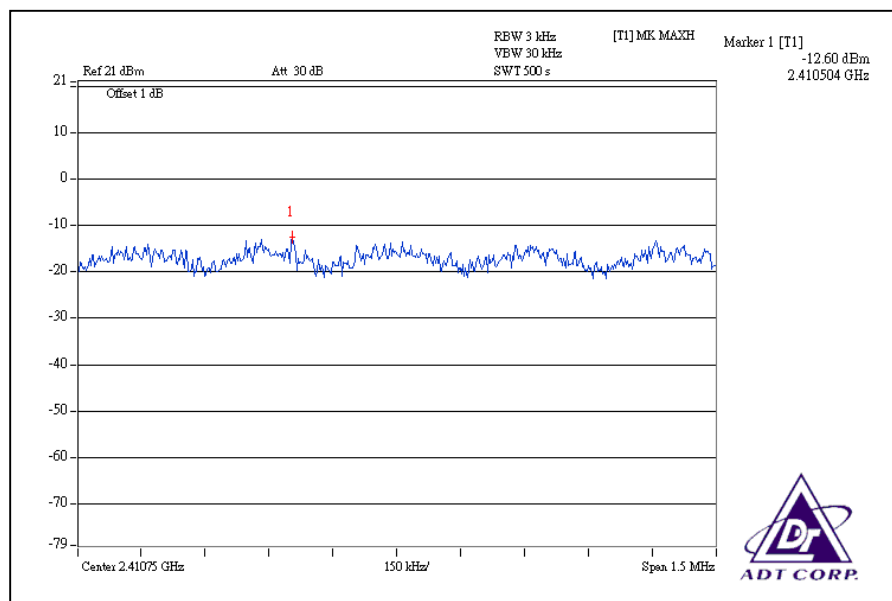



### CH6

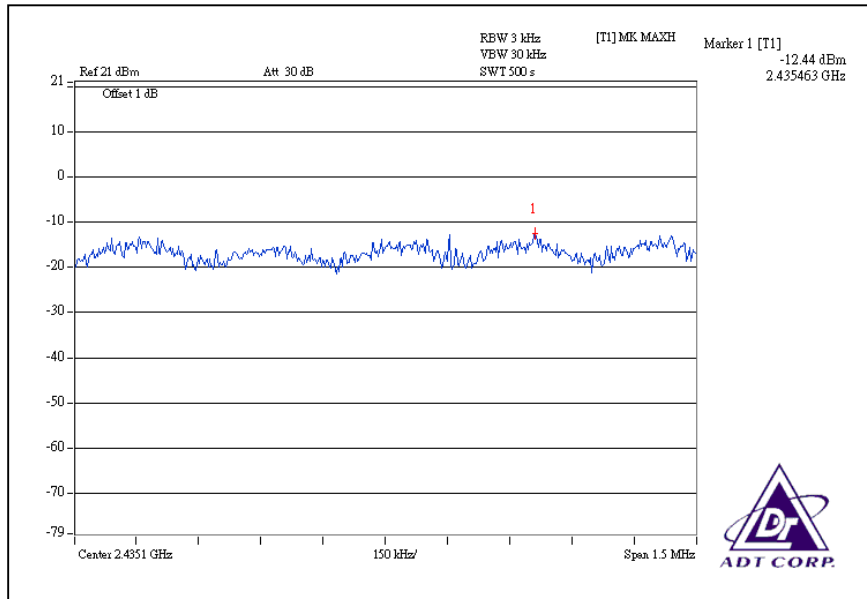

### CH11

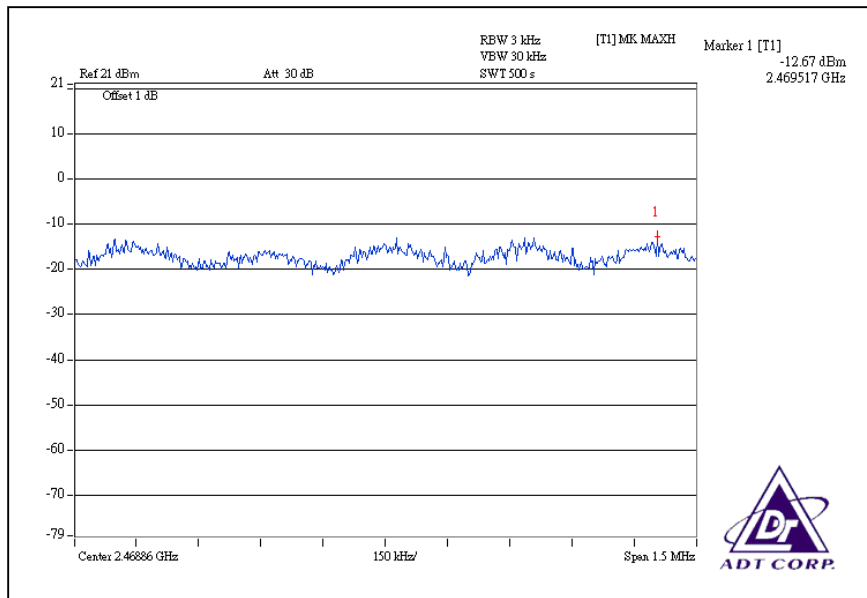

## 4.6 BAND EDGES MEASUREMENT

### 4.6.1 LIMITS OF BAND EDGES MEASUREMENT

Below  $-20\text{dB}$  of the highest emission level of operating band (in 100KHz Resolution Bandwidth).

### 4.6.2 TEST INSTRUMENTS

Description & Manufacturer	Model No.	Serial No.	Calibrated Until
R&S SPECTRUM ANALYZER	FSP40	100037	Sep. 06, 2008

**NOTE:**

- 1.The measurement uncertainty is less than  $\pm 2.6\text{dB}$ , which is calculated as per the NAMAS document NIS81. This uncertainty represents an expanded uncertainty expressed at approximately the 95% confidence level using a coverage factor of  $k=2$ .
- 2.The calibration interval of the above test instruments is 12 months and the calibrations are traceable to NML/ROC and NIST/USA.

### 4.6.3 TEST PROCEDURE

The transmitter output was connected to the spectrum analyzer via a low lose cable. Set both RBW of spectrum analyzer to 100kHz and VBW of spectrum analyzer to 300kHz with suitable frequency span including 100 MHz bandwidth from band edge. The band edges was measured and recorded.

The spectrum plots (RBW = 100kHz & VBW = 300kHz) are attached on the following pages.

#### 4.6.4 DEVIATION FROM TEST STANDARD

No deviation

#### 4.6.5 EUT OPERATING CONDITION

Same as Item 4.3.6

#### 4.6.6 TEST RESULTS

The spectrum plots are attached on the following pages. D1 line indicates the highest level, and D2 line indicates the 20dB offset below D1. It shows compliance with the requirement in part 15.247(d).

## 802.11b DSSS MODULATION: CH1

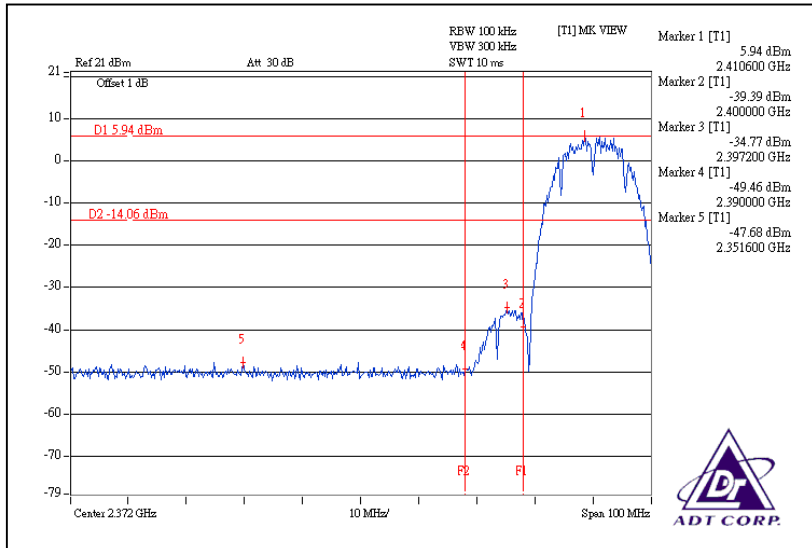

## CH11

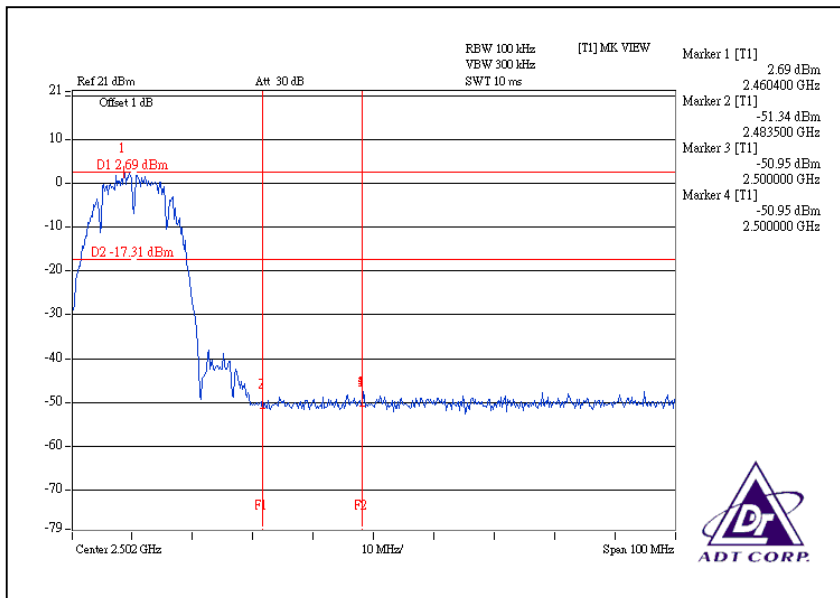

### CH1

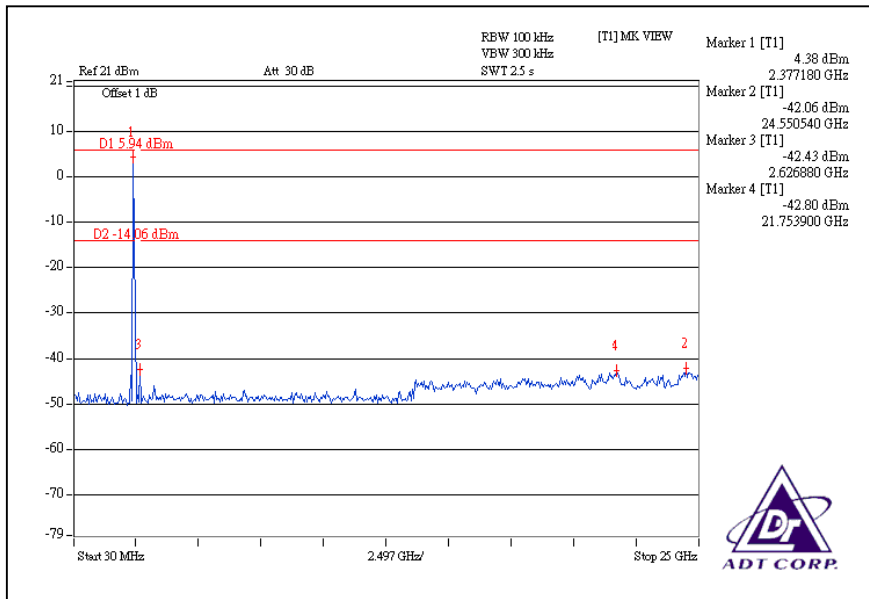

### CH11

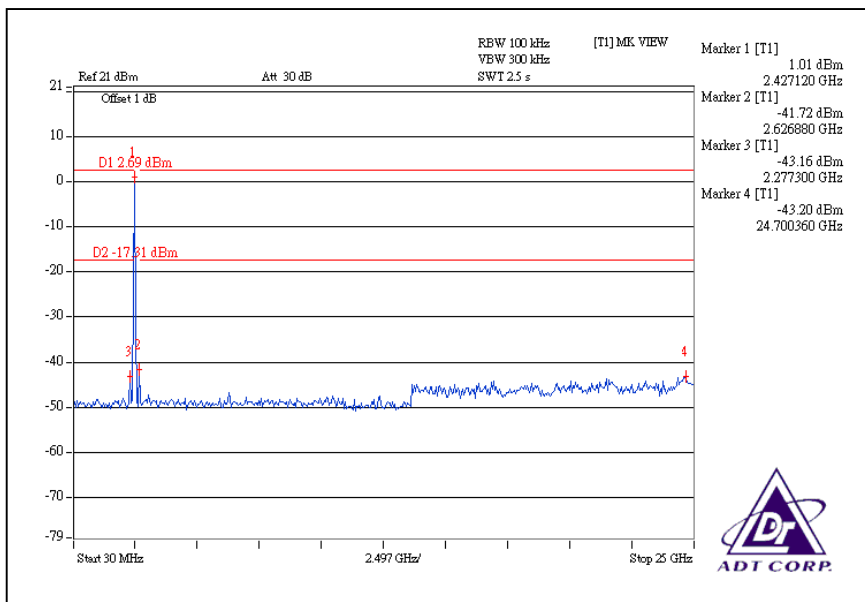

## 802.11g OFDM MODULATION: CH1

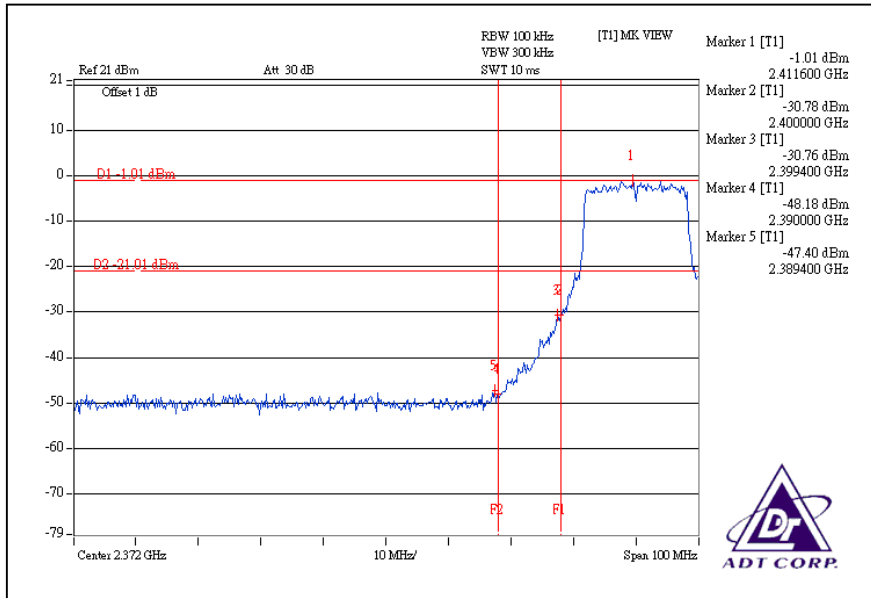

## CH11

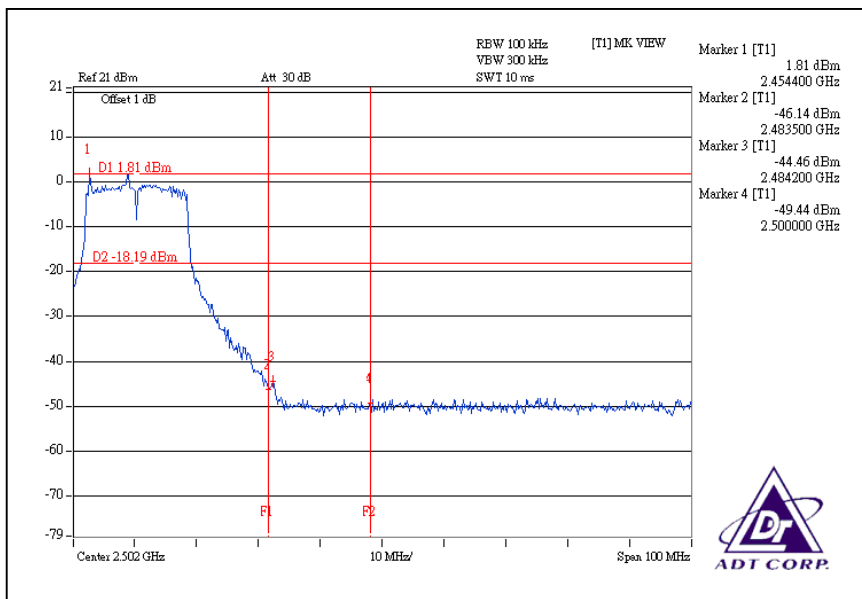

### CH1

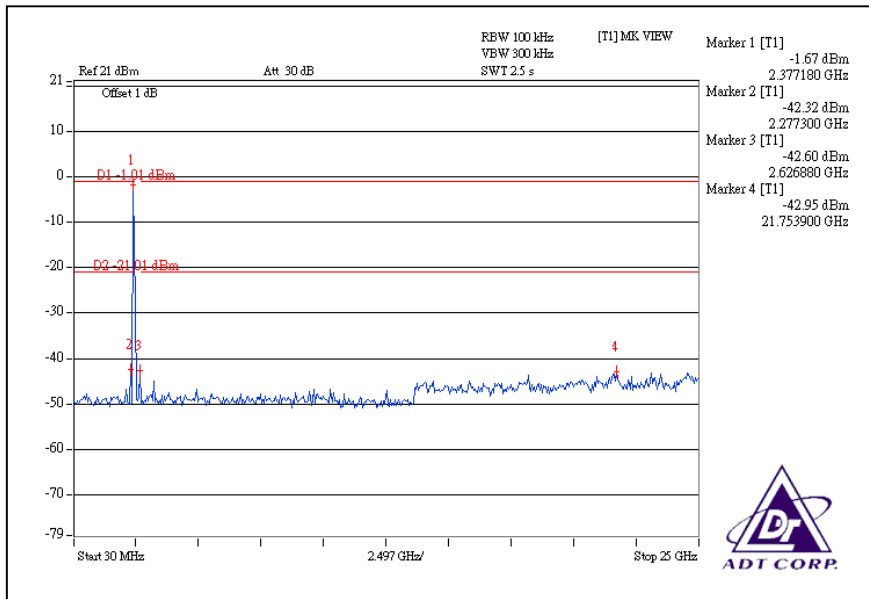

### CH11

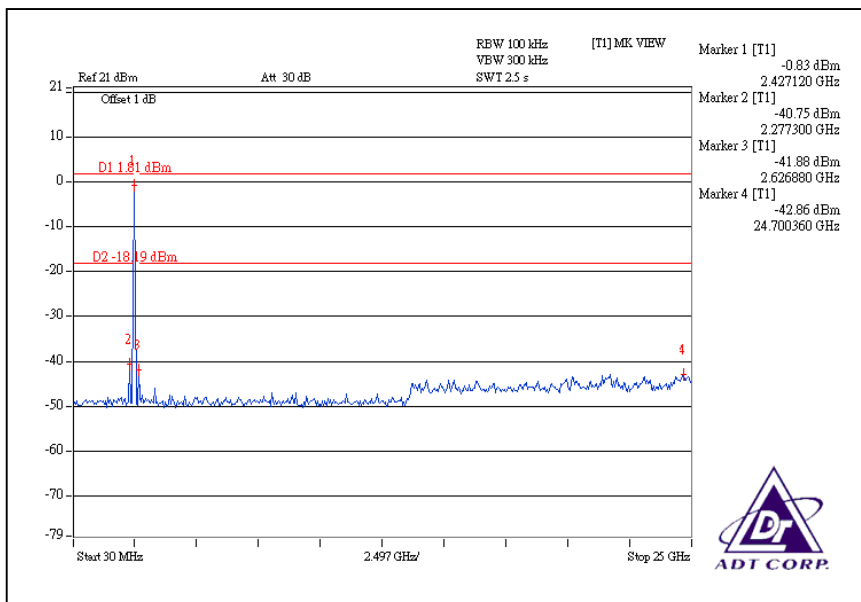

## 4.7 ANTENNA REQUIREMENT

### 4.7.1 STANDARD APPLICABLE

For intentional device, according to FCC 47 CFR Section 15.203, an intentional radiator shall be designed to ensure that no antenna other than that furnished by the responsible party shall be used with the device. And according to FCC 47 CFR Section 15.247 (b), if transmitting antennas of directional gain greater than 6dBi are used, the power shall be reduced by the amount in dB that the directional gain of the antenna exceeds 6dBi.

### 4.7.2 ANTENNA CONNECTED CONSTRUCTION

There are two printed antennas provided to this EUT, and the following two dipole antennas are option:

Antenna	Antenna Type	Antenna Connector	Gain (dBi)	Function	Note
Antenna 1	Printed	NA	1	Only RX	Fixed
Antenna 2	Printed	I-PEX	1	TX / RX	
Antenna 3	Dipole	MMCX	2		
Antenna 4	Dipole	MMCX	5		For Option





## 5. INFORMATION ON THE TESTING LABORATORIES

We, ADT Corp., were founded in 1988 to provide our best service in EMC, Radio, Telecom and Safety consultation. Our laboratories are accredited and approved by the following approval agencies according to ISO/IEC 17025.

<b>USA</b>	FCC, UL, A2LA
<b>Germany</b>	TUV Rheinland
<b>Japan</b>	VCCI
<b>Norway</b>	NEMKO
<b>Canada</b>	INDUSTRY CANADA , CSA
<b>R.O.C.</b>	TAF, BSMI, NCC
<b>Netherlands</b>	Telefication
<b>Singapore</b>	GOST-ASIA(MOU)
<b>Russia</b>	CERTIS(MOU)

Copies of accreditation certificates of our laboratories obtained from approval agencies can be downloaded from our web site:

[www.adt.com.tw/index.5/phtml](http://www.adt.com.tw/index.5/phtml). If you have any comments, please feel free to contact us at the following:

**Linko EMC/RF Lab:**  
Tel: 886-2-26052180  
Fax: 886-2-26052943

**Hsin Chu EMC/RF Lab:**  
Tel: 886-3-5935343  
Fax: 886-3-5935342

**Hwa Ya EMC/RF/Safety Telecom Lab:**  
Tel: 886-3-3183232  
Fax: 886-3-3185050

**Web Site:** [www.adt.com.tw](http://www.adt.com.tw)

The address and road map of all our labs can be found in our web site also



## **6. APPENDIX A - MODIFICATIONS RECORDERS FOR ENGINEERING CHANGES TO THE EUT BY THE LAB**

No any modifications are made to the EUT by the lab during the test.