



**FCC 47 CFR PART 15 SUBPART C
INDUSTRY CANADA RSS-247 ISSUE 2**

CERTIFICATION TEST REPORT

For

**Bluetooth Headphone
MODEL NUMBER: SPACE ONE WIRELESS**

**FCC ID: UXDF398801
IC: 21561-F398801**

REPORT NUMBER: 4788045470.3-7

ISSUE DATE: July 19, 2017

Prepared for

**GP Electronics (HK) Ltd.
9/F, Building 12W, 12 Science Park West Avenue, Hong Kong Science Park, Pak
Shek Kok, New Territories, Hong Kong**

Prepared by

**UL Verification Services (Guangzhou) Co., Ltd, Song Shan Lake Branch
Room 101, Building 10, Innovation Technology Park,
Song Shan Lake Hi tech Development Zone, Dongguan, 523808, China
Tel: +86 769 33817100
Fax: +86 769 33244054
Website: www.ul.com**

Revision History

<u>Rev.</u>	<u>Issue Date</u>	<u>Revisions</u>	<u>Revised By</u>
--	07/19/2017	Initial Issue	

Summary of Test Results			
Clause	Test Items	FCC/IC Rules	Test Results
1	6db DTS Bandwidth	FCC 15.247 (a) (2) IC RSS-247 Clause 5.1 (1)	Complied
2	Peak Conducted Power	FCC 15.247 (b) (3) IC RSS-247 Clause 5.4 (4)	Complied
3	Power Spectral Density	FCC 15.247 (3) IC RSS-247 Clause 5.2 (2)	Complied
4	Conducted Band edge And Spurious emission	FCC 15.247 (d) IC RSS-247 Clause 5.5	Complied
5	Radiated Band edges and Spurious emission	FCC 15.247 (d) FCC 15.209 FCC 15.205 IC RSS-247 Clause 5.5 IC RSS-GEN Clause 8.9	Complied
6	Conducted Emission Test For AC Power Port	FCC 15.207 RSS-GEN Clause 8.8	Complied
7	Antenna Requirement	FCC 15.203 RSS-GEN Clause 8.3	Complied

TABLE OF CONTENTS

1. ATTESTATION OF TEST RESULTS	5
2. TEST METHODOLOGY	6
3. FACILITIES AND ACCREDITATION	6
4. CALIBRATION AND UNCERTAINTY	7
4.1. <i>MEASURING INSTRUMENT CALIBRATION</i>	7
4.2. <i>MEASUREMENT UNCERTAINTY</i>	7
5. EQUIPMENT UNDER TEST	8
5.1. <i>DESCRIPTION OF EUT</i>	8
5.2. <i>MAXIMUM OUTPUT POWER</i>	8
5.3. <i>CHANNEL LIST</i>	8
5.4. <i>TEST CHANNEL CONFIGURATION</i>	8
5.5. <i>THE WORSE CASE POWER SETTING PARAMETER</i>	9
5.6. <i>DESCRIPTION OF AVAILABLE ANTENNAS</i>	9
5.7. <i>WORST-CASE CONFIGURATIONS</i>	9
5.8. <i>TEST ENVIRONMENT</i>	9
5.9. <i>DESCRIPTION OF TEST SETUP</i>	10
5.10. <i>MEASURING INSTRUMENT AND SOFTWARE USED</i>	11
6. ANTENNA PORT TEST RESULTS	12
6.1. <i>ON TIME AND DUTY CYCLE</i>	12
6.2. <i>6 dB BANDWIDTH & 99% BANDWIDTH</i>	13
6.2.1. <i>GFSK MODE</i>	14
6.3. <i>PEAK CONDUCTED OUTPUT POWER</i>	16
6.4. <i>POWER SPECTRAL DENSITY</i>	19
6.5. <i>CONDUCTED BANDEDGE AND SPURIOUS EMISSIONS</i>	22
7. RADIATED TEST RESULTS	31
7.1. <i>LIMITS AND PROCEDURE</i>	31
7.2. <i>RESTRICTED BANDEDGE</i>	35
7.3. <i>SPURIOUS EMISSIONS (1~25GHz)</i>	39
7.4. <i>SPURIOUS EMISSIONS 30M ~ 1 GHz</i>	51
7.5. <i>SPURIOUS EMISSIONS BELOW 30M</i>	53
8. AC POWER LINE CONDUCTED EMISSIONS	55
9. ANTENNA REQUIREMENTS	58

1. ATTESTATION OF TEST RESULTS

Applicant Information

Company Name: GP Electronics (HK) Ltd.
Address: 9/F, Building 12W, 12 Science Park West Avenue, Hong Kong Science Park, Pak Shek Kok, New Territories, Hong Kong

Manufacturer Information

Company Name: GP Electronics (Huizhou) Co., Limited
Address: No. 76, Hui Feng Si Road, Zhong Kai Hi-Tech Ind. Development Zone, Huizhou, Guangdong, China

Factory Information

Company Name: Charter Media (Dongguan) Co., Ltd.
Address: Dabandi Industrial Zone, Daning District, Humen Town, 523930 Dongguan City, Guangdong Province, PEOPLE'S REPUBLIC OF CHINA

EUT Description

Product Name: Bluetooth Headphone
Brand Name: KEF
Model Name: SPACE ONE WIRELESS
Date Tested: July 4, 2017 ~ July 18, 2017

APPLICABLE STANDARDS	
STANDARD	TEST RESULTS
CFR 47 Part 15 Subpart C	PASS
INDUSTRY CANADA RSS-247 Issue 2	PASS
INDUSTRY CANADA RSS-GEN Issue 4	PASS

Tested By:

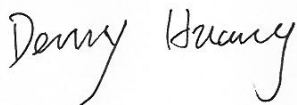

Denny Huang
Engineer Project Associate
Approved By:



Stephen Guo
Laboratory Manager

Check By:



Shawn Wen
Laboratory Leader

2. TEST METHODOLOGY

The tests documented in this report were performed in accordance with KDB 558074 D01 V04, ANSI C63.10-2013, FCC CFR 47 Part 2, FCC CFR 47 Part 15, RSS-GEN Issue 4, and RSS-247 Issue 2.

3. FACILITIES AND ACCREDITATION

Test Location	Dongguan Dongdian Testing Service Co., Ltd
Address	No. 17, Zongbu Road 2, Songshan Lake Sci&Tech Park, Dongguan City, Guangdong Province, 523808, China
Accreditation Certificate	<p>Dongguan Dongdian Testing Service Co., Ltd. EMC Laboratory has been accredited by A2LA for technical competence in the field of electrical testing, and proved to be in compliance with ISO/IEC 17025: 2005 General Requirements for the Competence of Testing and Calibration Laboratories and any additional program requirements in the identified field of testing. Valid time is until January 31, 2018.</p> <p>Dongguan Dongdian Testing Service Co., Ltd. EMC Laboratory has been registered and fully described in a report filed with the FCC (Federal Communications Commission). The acceptance letter from the FCC is maintained in our files. Registration 270092, Renewal date March 11, 2015, valid time is until March 11, 2018.</p> <p>The 3m Alternate Test Site of Dongguan Dongdian Testing Service Co., Ltd. has been registered by Certification and Engineering Bureau of Industry Canada for the performance of radiated measurements with Registration No. 10288A on April 23, 2015, valid time is until April 23, 2018.</p>

Note: The test anechoic chamber in Dongguan Dongdian Testing Service Co., Ltd had been calibrated and compared to the open field sites.

4. CALIBRATION AND UNCERTAINTY

4.1. MEASURING INSTRUMENT CALIBRATION

The measuring equipment utilized to perform the tests documented in this report has been calibrated in accordance with the manufacturer's recommendations, and is traceable to recognized national standards.

4.2. MEASUREMENT UNCERTAINTY

Where relevant, the following measurement uncertainty levels have been estimated for tests performed on the apparatus:

Test Item	Uncertainty
Uncertainty for Conduction emission test	3.32dB (150KHz-30MHz)
	3.72dB (9KHz-150KHz)
Uncertainty for Radiation Emission test(include Fundamental emission) (30MHz-1GHz)	4.70 dB (Antenna Polarize: V)
	4.84 dB (Antenna Polarize: H)
Uncertainty for Radiation Emission test (1GHz to 26GHz)(include Fundamental emission)	4.10dB(1-6GHz)
	4.40dB (6GHz-18Gz)
	3.54dB (18GHz-26Gz)
Bandwidth	1.1%
Stop Transmitting Time Test	0.6%
Note: This uncertainty represents an expanded uncertainty expressed at approximately the 95% confidence level using a coverage factor of k=2.	

5. EQUIPMENT UNDER TEST

5.1. DESCRIPTION OF EUT

Equipment	Bluetooth Headphone		
Model Name	SPACE ONE WIRELESS		
Product Description (Bluetooth)	Operation Frequency	2402 MHz ~ 2480 MHz	
	Modulation Type	Data Rate	
	GFSK	1Mbps	
Rated Input	DC 5V, 600mA		
Battery	3.7V/850mAh		
Bluetooth Version	BT V4.1		
Hardware Version	V01		
Software Version	V1.0		

5.2. MAXIMUM OUTPUT POWER

Frequency Range (MHz)	Number of Transmit Chains (NTX)	Bluetooth Mode	Frequency (MHz)	Channel Number	Max PK Conducted Power (dBm)	EIRP (dBm)
2400-2483.5	1	BLE	2402-2480	0-39[40]	0.4	2.400

5.3. CHANNEL LIST

Channel	Frequency (MHz)	Channel	Frequency (MHz)	Channel	Frequency (MHz)	Channel	Frequency (MHz)
00	2402	11	2424	22	2446	33	2468
01	2404	12	2426	23	2448	34	2470
02	2406	13	2428	24	2450	35	2472
03	2408	14	2430	25	2452	36	2474
04	2410	15	2432	26	2454	37	2476
05	2412	16	2434	27	2456	38	2478
06	2414	17	2436	28	2458	39	2480
07	2416	18	2438	29	2460		
08	2418	19	2440	30	2462		
09	2420	20	2442	31	2464		
10	2422	21	2444	32	2466		

5.4. TEST CHANNEL CONFIGURATION

Test Mode	Test Channel	Frequency
GFSK	CH 00, CH 19, CH 39	2402MHz, 2440MHz, 2480MHz

5.5. THE WORSE CASE POWER SETTING PARAMETER

The Worse Case Power Setting Parameter under 2400 ~ 2483.5MHz Band				
Test Software Version		BlueTest 3		
Modulation Type	Transmit Antenna Number	Test Channel		
		CH 00	CH 19	CH 39
GFSK	1	Default	Default	Default

5.6. DESCRIPTION OF AVAILABLE ANTENNAS

Ant.	Frequency (MHz)	Antenna Type	Antenna Gain (dBi)
1	2402-2480	PCB Antenna	2.0

Test Mode	Transmit and Receive Mode	Description
GFSK	<input checked="" type="checkbox"/> 1TX, 1RX	Chain 1 can be used as transmitting/receiving antenna.

5.7. WORST-CASE CONFIGURATIONS

Bluetooth Mode	Modulation Technology	Modulation Type	Data Rate (Mbps)
BLE	DTS	GFSK	1Mbit/s

5.8. TEST ENVIRONMENT

Environment Parameter	Selected Values During Tests	
Relative Humidity	55 ~ 65%	
Atmospheric Pressure:	1025Pa	
Temperature	TN	23 ~ 28°C
	VL	N/A
Voltage :	VN	DC 3.7V/DC 5V
	VH	N/A

Note: VL= Lower Extreme Test Voltage
 VN= Nominal Voltage
 VH= Upper Extreme Test Voltage
 TN= Normal Temperature

5.9. DESCRIPTION OF TEST SETUP

SUPPORT EQUIPMENT

Item	Equipment	Brand Name	Model Name	FCC ID
1	Notebook	DELL	Latitude D610	N/A

I/O CABLES

Cable No	Port	Connector Type	Cable Type	Cable Length(cm)	Remarks
1	DC In	USB	Unshielded	20	N/A
2	Aux in	AUX	Unshielded	50	N/A

ACCESSORY

Item	Accessory	Brand Name	Model Name	Description
1	N/A	N/A	N/A	N/A

TEST SETUP

The EUT can work in an engineer mode with a software through a Laptop.

SETUP DIAGRAM FOR TESTS

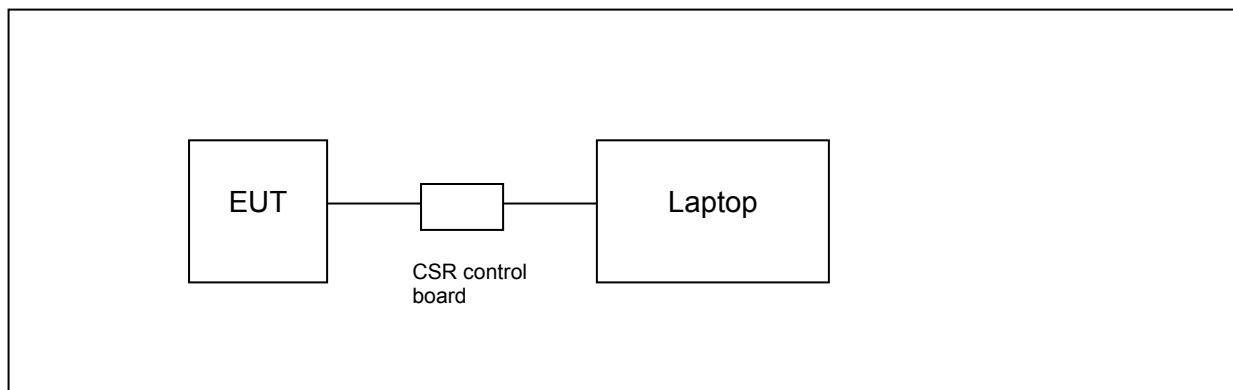

5.10. MEASURING INSTRUMENT AND SOFTWARE USED

Instrument (Conducted for RF Port)						
Used	Equipment	Manufacturer	Model No.	Serial No.	Last Cal.	Cal. Interval
<input checked="" type="checkbox"/>	Spectrum Analyzer	R&S	FSU26	1166.1660.26	2016/10/16	1 Year
Instrument (Radiated Tests)						
Used	Equipment	Manufacturer	Model No.	Serial No.	Last Cal.	Expired date
<input checked="" type="checkbox"/>	EMI Test Receiver	R&S	ESU8	100316	2016/10/16	1 Year
<input checked="" type="checkbox"/>	Spectrum analyzer	R&S	FSU26	1166.1660.26	2016/10/16	1 Year
<input checked="" type="checkbox"/>	Trilog Broadband Antenna	Schwarzbeck	VULB9163	9163-462	2016/10/27	1 Year
<input checked="" type="checkbox"/>	Active Loop antenna	Schwarzbeck	FMZB-1519	1519-038	2016/10/27	1 Year
<input checked="" type="checkbox"/>	Double Ridged Horn Antenna	R&S	HF907	100276	2016/10/12	1 Year
<input checked="" type="checkbox"/>	High Gain Horn Antenna	ETS-LINDGERN	3160-09	SEL0076	2016/10/16	1 Year
<input checked="" type="checkbox"/>	Pre-amplifier	A.H.	PAM-0118	360	2016/10/16	1 Year
<input checked="" type="checkbox"/>	Pre-amplifier	Compliance Directions Systems Inc.	PAP-1G26-48	6279.628	2017/01/05	1 Year
<input checked="" type="checkbox"/>	RF Cable	HUBSER	CP-X2	W11.03	2016/10/16	1 Year
<input checked="" type="checkbox"/>	RF Cable	HUBSER	CP-X1	W12.02	2016/10/16	1 Year
<input checked="" type="checkbox"/>	MI Cable	HUBSER	C10-01-01-1M	1091629	2016/10/16	1 Year
<input checked="" type="checkbox"/>	Test software	Audix	E3	V 6.11111b	N/A	N/A
Instrument (Line Conducted Emission (AC Main))						
Used	Equipment	Manufacturer	Model No.	Serial No.	Last Cal.	Expired date
<input checked="" type="checkbox"/>	Test Receiver	R&S	ESU8	100316	2016/10/16	1 Year
<input checked="" type="checkbox"/>	LISN 1	R&S	ENV216	101109	2016/10/16	1 Year
<input checked="" type="checkbox"/>	LISN 2	R&S	ESH2-Z5	100309	2016/10/16	1 Year
<input checked="" type="checkbox"/>	Pulse Limiter	R&S	ESH3-Z2	101242	2016/10/16	1 Year
<input checked="" type="checkbox"/>	CE Cable 1	HUBSER	ESU8/RF2	W10.01	2016/10/16	1 Year
<input checked="" type="checkbox"/>	Test software	Audix	E3	V 6.11111b	N/A	N/A

6. ANTENNA PORT TEST RESULTS

6.1. ON TIME AND DUTY CYCLE

LIMITS

None; for reporting purposes only

PROCEDURE

KDB 558074 Zero-Span Spectrum Analyzer Method

TEST SETUP

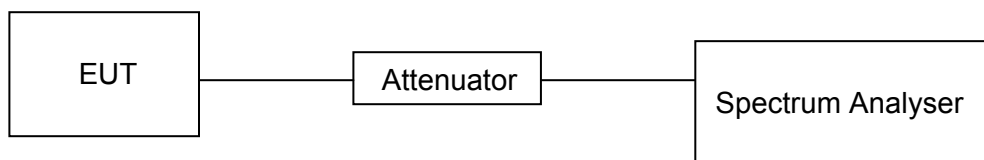

RESULTS

Mode	On Time (msec)	Period (msec)	Duty Cycle x (Linear)	Duty Cycle (%)	Duty Cycle Correction Factor (db)	1/B Minimum VBW (KHz)
GFSK	0.377	0.649	0.581	58.1	2.36	1.72

Note: Duty Cycle Correction Factor=10log(1/x).
 Where: x is Duty Cycle(Linear)

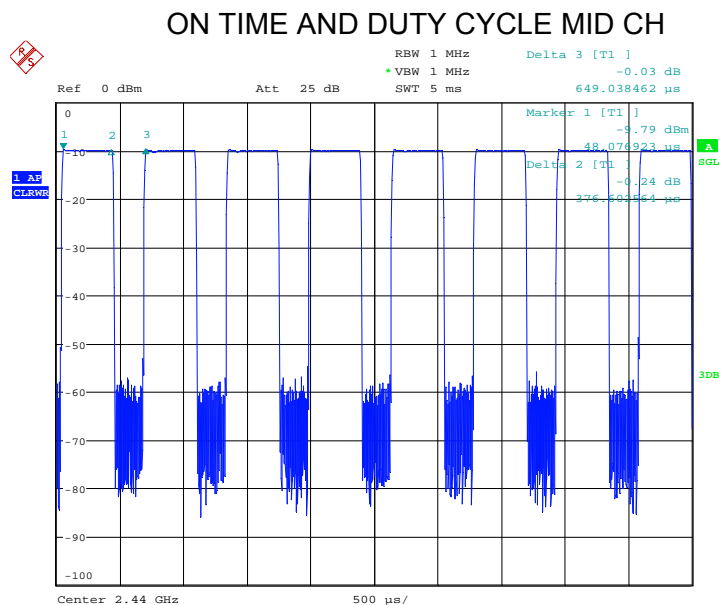

Date: 18.JUL.2017 14:21:33

6.2. 6 dB BANDWIDTH & 99% BANDWIDTH

LIMITS

FCC Part15 (15.247) , Subpart C			
Section	Test Item	Limit	Frequency Range (MHz)
FCC 15.247 (a) (1)	6dB Bandwidth	>= 500KHz	2400-2483.5

TEST PROCEDURE

Connect the UUT to the spectrum analyser and use the following settings:

Center Frequency	The centre frequency of the channel under test
Detector	Peak
RBW	100K
VBW	$\geq 3 \times \text{RBW}$
Trace	Max hold
Sweep	Auto couple

Allow the trace to stabilize and measure the maximum width of the emission that is constrained by the frequencies associated with the two outermost amplitude points (upper and lower frequencies) that are attenuated by 6 dB relative to the maximum level measured in the fundamental emission.

TEST SETUP

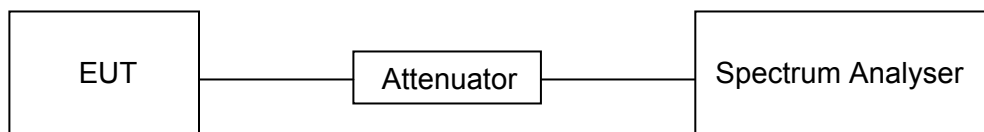

RESULTS

6.2.1. GFSK MODE

Channel	Frequency (MHz)	6dB bandwidth (MHz)	99% Bandwidth (MHz)	Result
Low	2402	0.704	1.056	Pass
Middle	2441	0.696	1.048	Pass
High	2480	0.700	1.044	Pass

Test Graphs

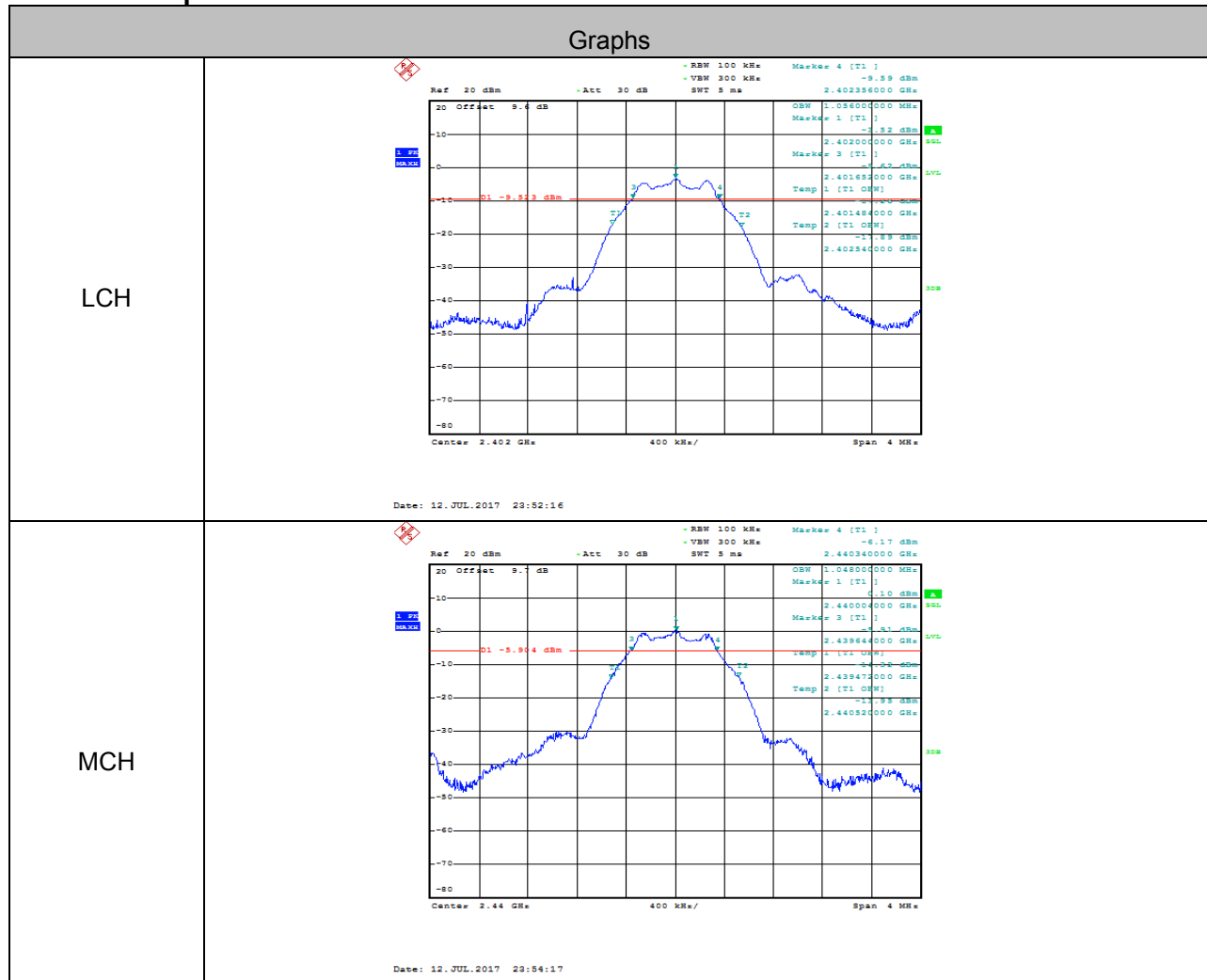

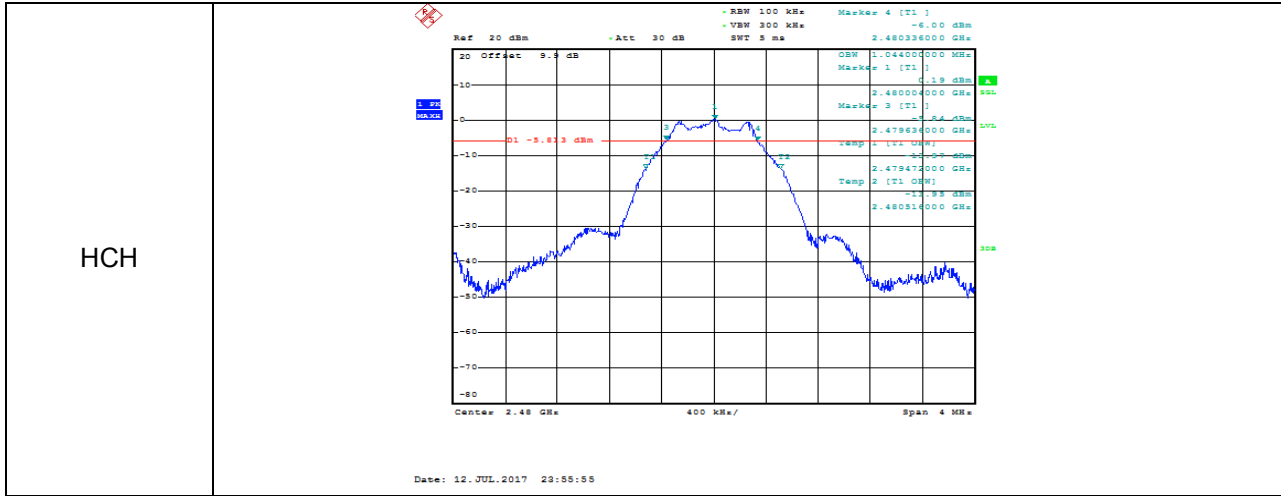

6.3. PEAK CONDUCTED OUTPUT POWER

LIMITS

FCC Part15 (15.247) , Subpart C IC RSS-247 ISSUE 2			
Section	Test Item	Limit	Frequency Range (MHz)
FCC 15.247(b)(3) IC RSS-247 5.4 (4)	Peak Output Power	1 watt or 30dBm	2400-2483.5

TEST PROCEDURE

Connect the UUT to the spectrum analyser and use the following settings:

Center Frequency	The centre frequency of the channel under test
Detector	Peak
RBW	\geq DTS bandwidth(e.g. 1 MHz for BLE)
VBW	$\geq 3 \times$ RBW
Span	$3 \times$ RBW
Trace	Max hold
Sweep time	Auto couple.

Allow trace to fully stabilize and use peak marker function to determine the peak amplitude level.

TEST SETUP

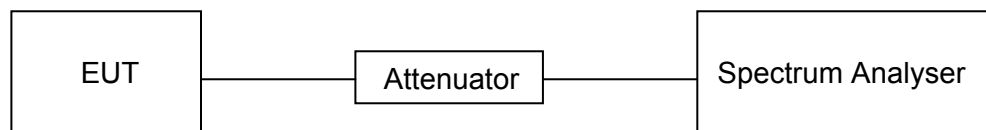

RESULTS

Test Channel	Frequency	Maximum Conducted Output Power(PK)	EIRP	LIMIT
	(MHz)	(dBm)	(dBm)	dBm
CH00	2402	-3.260	-1.260	30
CH19	2440	0.320	2.320	30
CH39	2480	0.400	2.400	30

Note: EIRP = Maximum Conducted Output Power (PK) + Antenna Gain

Test Graphs

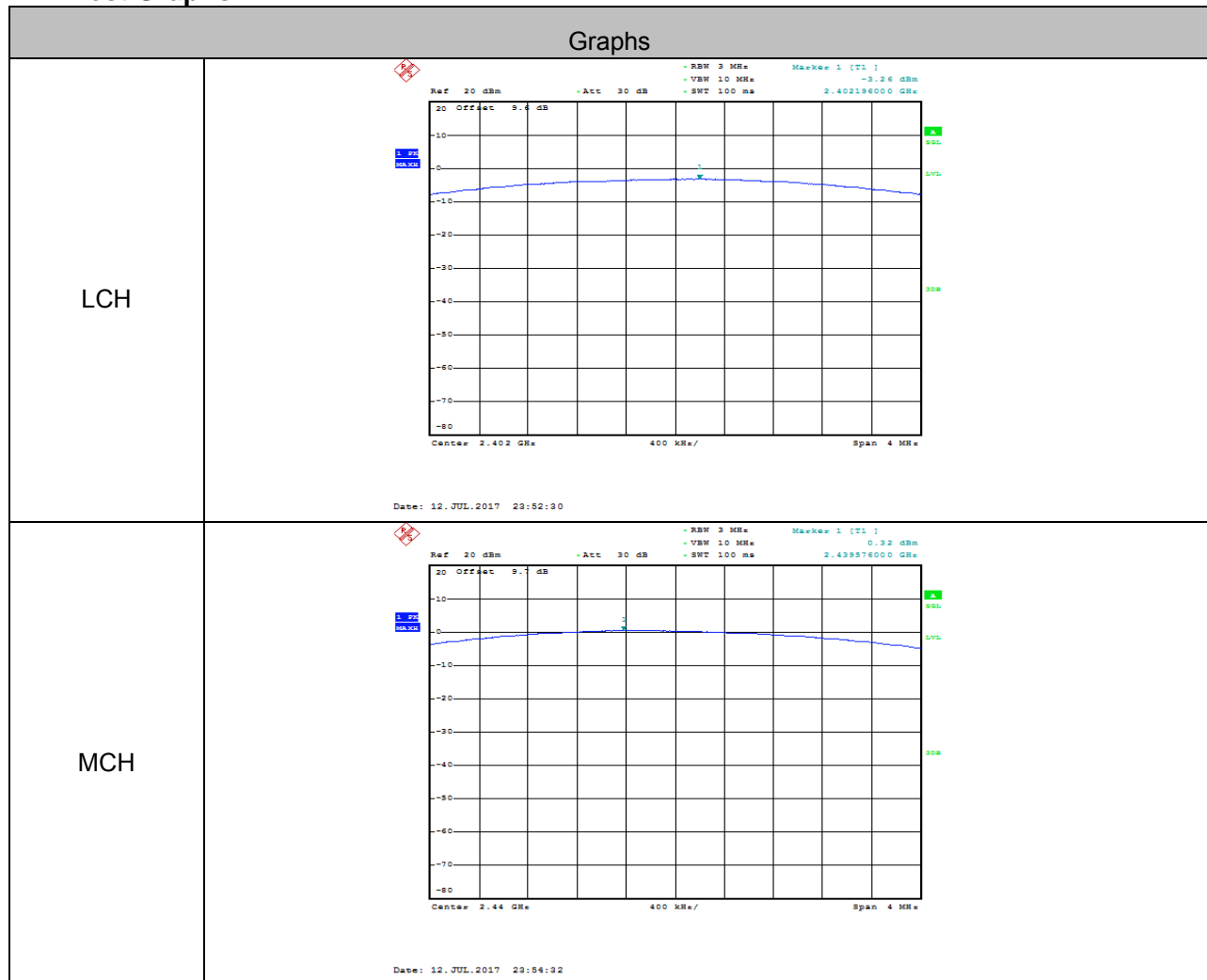

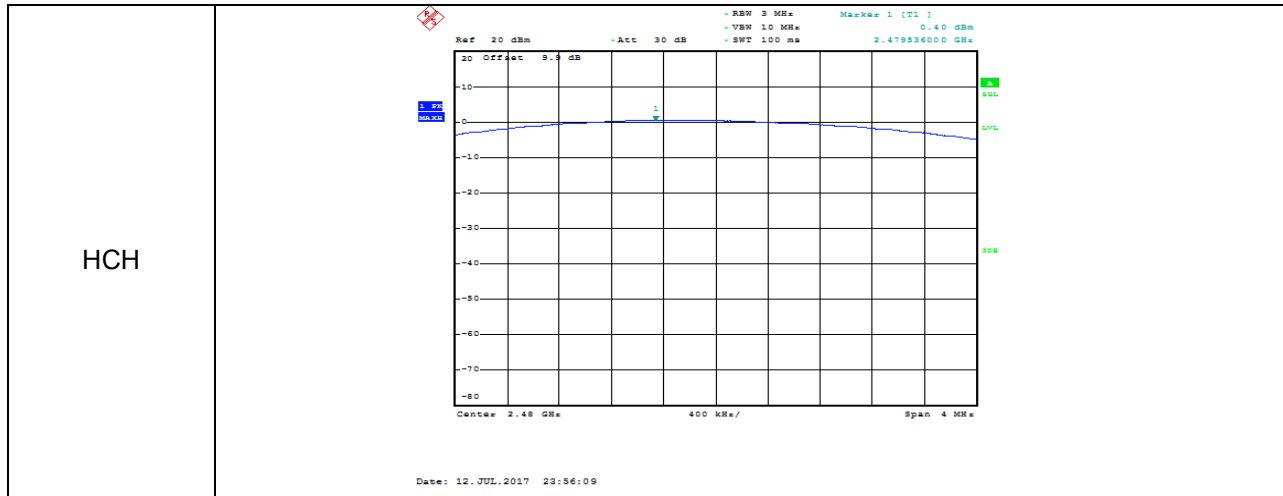

6.4. POWER SPECTRAL DENSITY

LIMITS

FCC Part15 (15.247) , Subpart C IC RSS-247 ISSUE 2			
Section	Test Item	Limit	Frequency Range (MHz)
FCC §15.247 (e) IC RSS-247 5.2 (2)	Power Spectral Density	8 dBm in any 3 kHz band	2400-2483.5

TEST PROCEDURE

Connect the UUT to the spectrum analyser and use the following settings:

Center Frequency	The centre frequency of the channel under test
Detector	Peak
RBW	$3 \text{ kHz} \leq \text{RBW} \leq 100\text{kHz}$
VBW	$\geq 3 \times \text{RBW}$
Span	1.5 x DTS bandwidth
Trace	Max hold
Sweep time	Auto couple.

Allow trace to fully stabilize and use the peak marker function to determine the maximum amplitude level within the RBW.

If measured value exceeds limit, reduce RBW (no less than 3 kHz) and repeat.

TEST SETUP

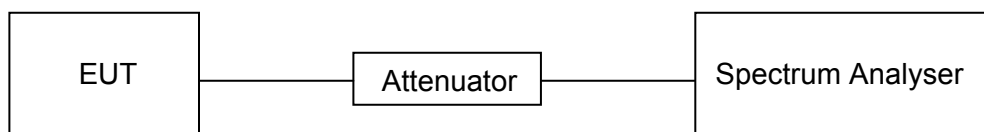

Frequency	Power Spectral Density (dBm)	Limit (dBm)	Result
2402 MHz	-3.520	8	PASS
2440 MHz	0.100	8	PASS
2480 MHz	0.190	8	PASS

Test Graphs

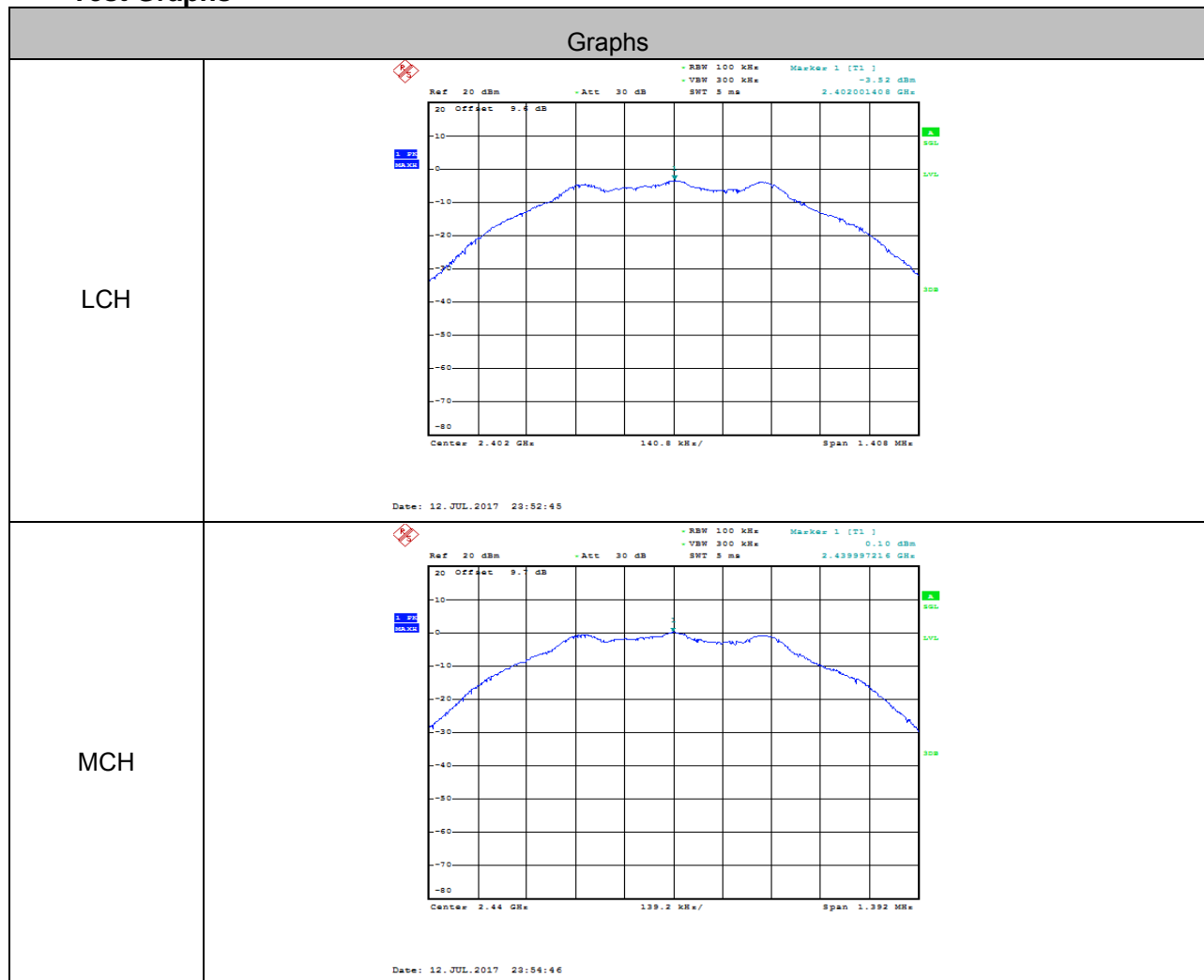

6.5. CONDUCTED BANDEGE AND SPURIOUS EMISSIONS

LIMITS

FCC Part15 (15.247) , Subpart C IC RSS-247 ISSUE 2		
Section	Test Item	Limit
FCC §15.247 (d) IC RSS-247 5.5	Conducted Bandedge and Spurious Emissions	at least 20 dB below that in the 100 kHz bandwidth within the band that contains the highest level of the desired power

TEST PROCEDURE

Connect the UUT to the spectrum analyser and use the following settings:

Center Frequency	The centre frequency of the channel under test
Detector	Peak
RBW	100K
VBW	$\geq 3 \times \text{RBW}$
Span	1.5 x DTS bandwidth
Trace	Max hold
Sweep time	Auto couple.

Use the peak marker function to determine the maximum PSD level.

Span	Set the center frequency and span to encompass frequency range to be measured
Detector	Peak
RBW	100K
VBW	$\geq 3 \times \text{RBW}$
measurement points	$\geq \text{span}/\text{RBW}$
Trace	Max hold
Sweep time	Auto couple.

Use the peak marker function to determine the maximum amplitude level.

TEST SETUP

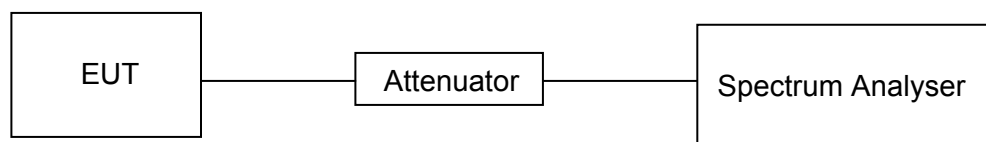

RESULTS

Conducted Bandedge

Channel	Carrier Frequency [MHz]	Carrier Power [dBm]	Max Spurious Level [dBm]	Limit [dBm]	Results
LCH	2402	-3.830	-47.504	-23.83	PASS
HCH	2480	0.110	-46.219	-19.89	PASS

Test Graphs

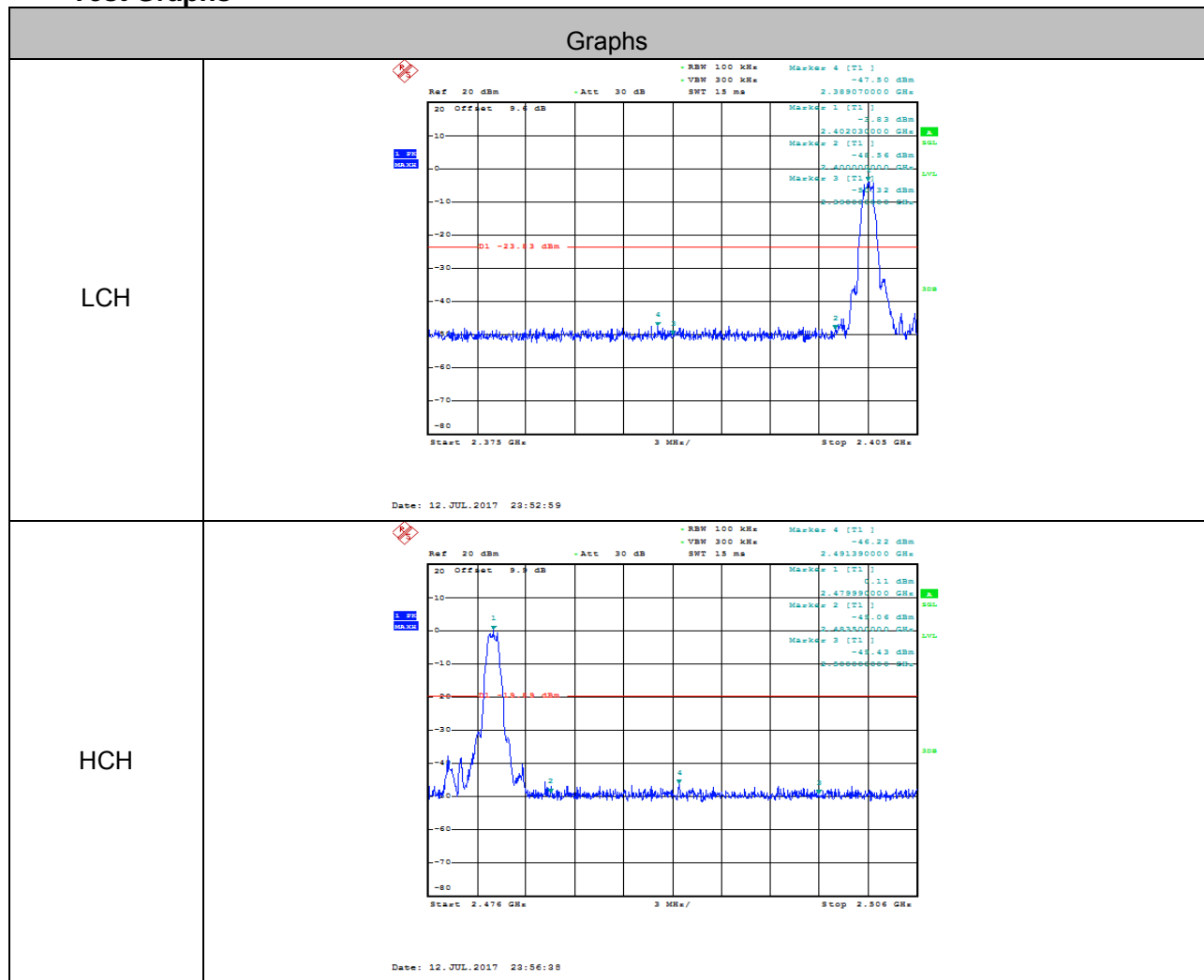

Conducted Spurious Emissions

Result Table

Mode	Channel	Pref [dBm]	Puw[dBm]	Verdict
BLE	LCH	-3.55	<Limit	PASS
BLE	MCH	0.07	<Limit	PASS
BLE	HCH	0.38	<Limit	PASS

Test Graphs

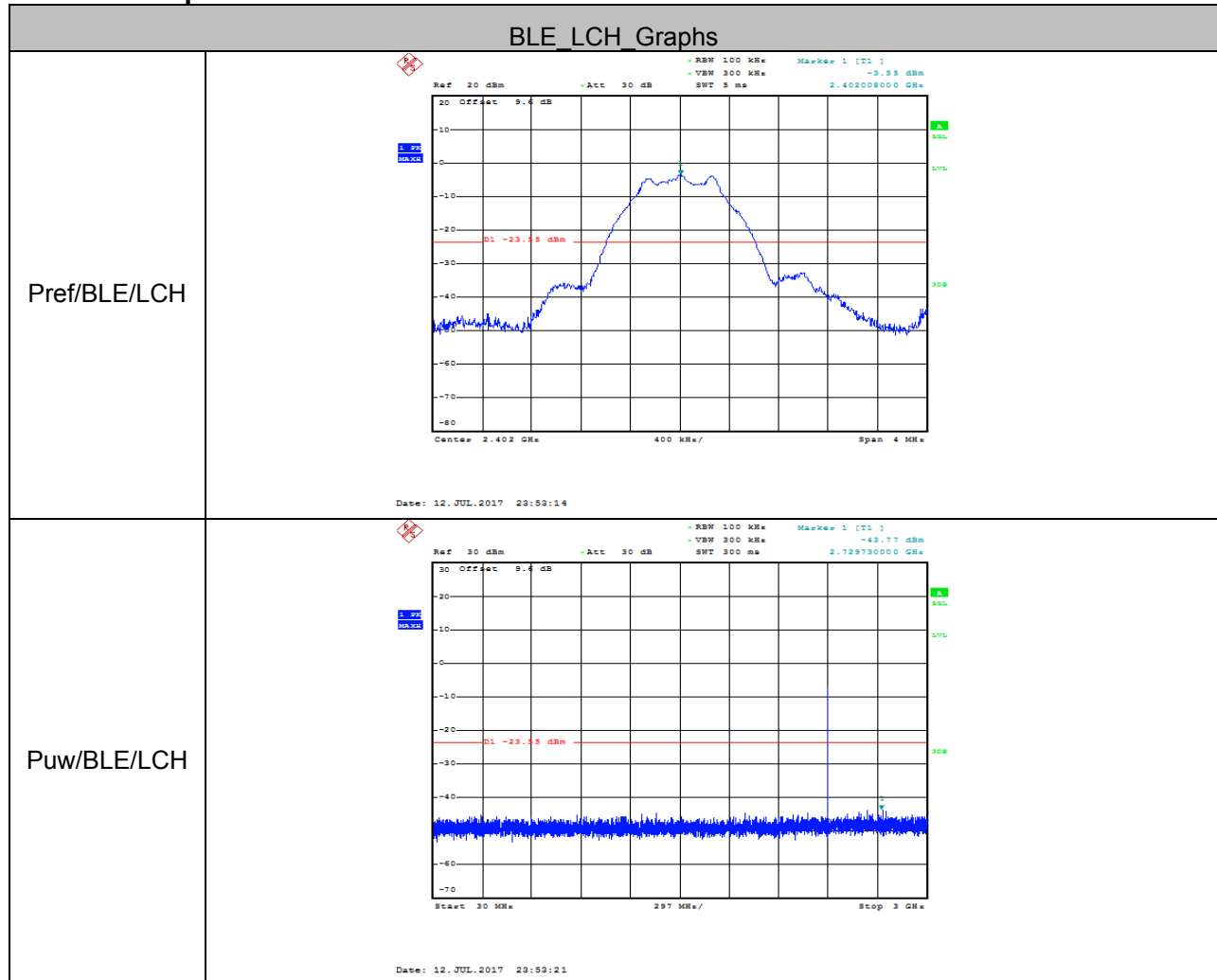



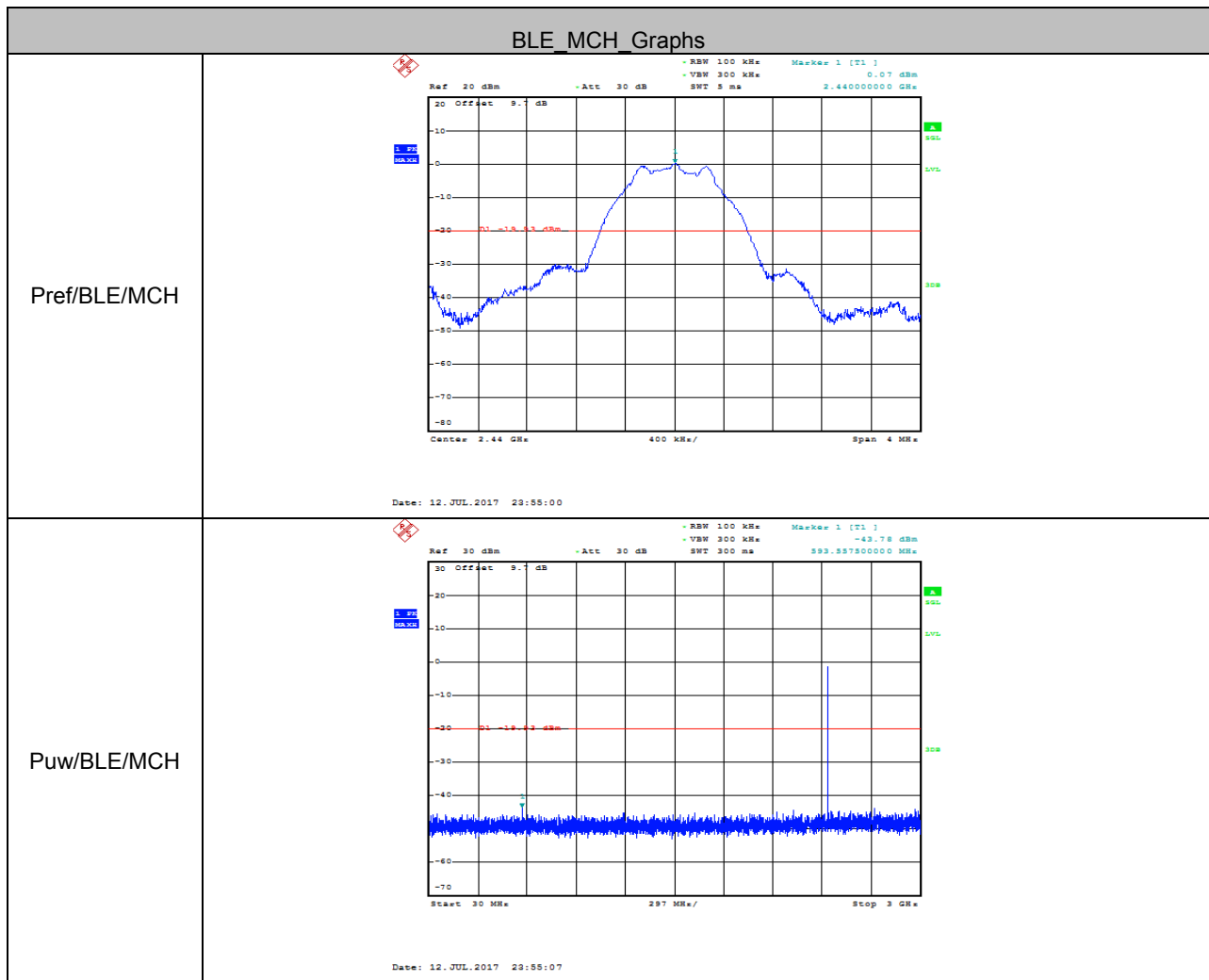
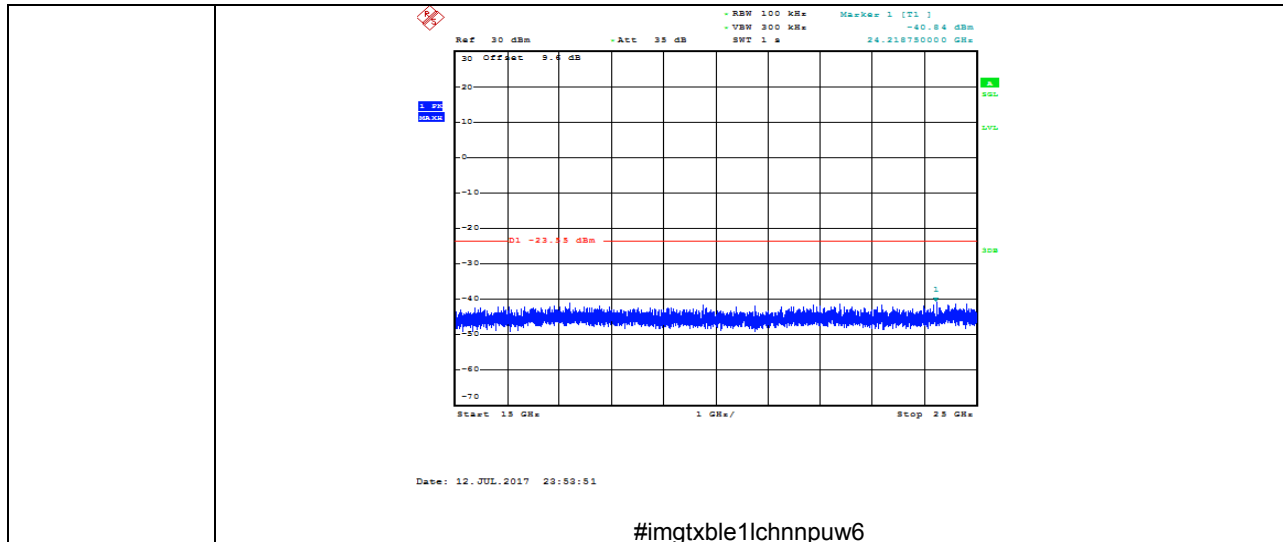

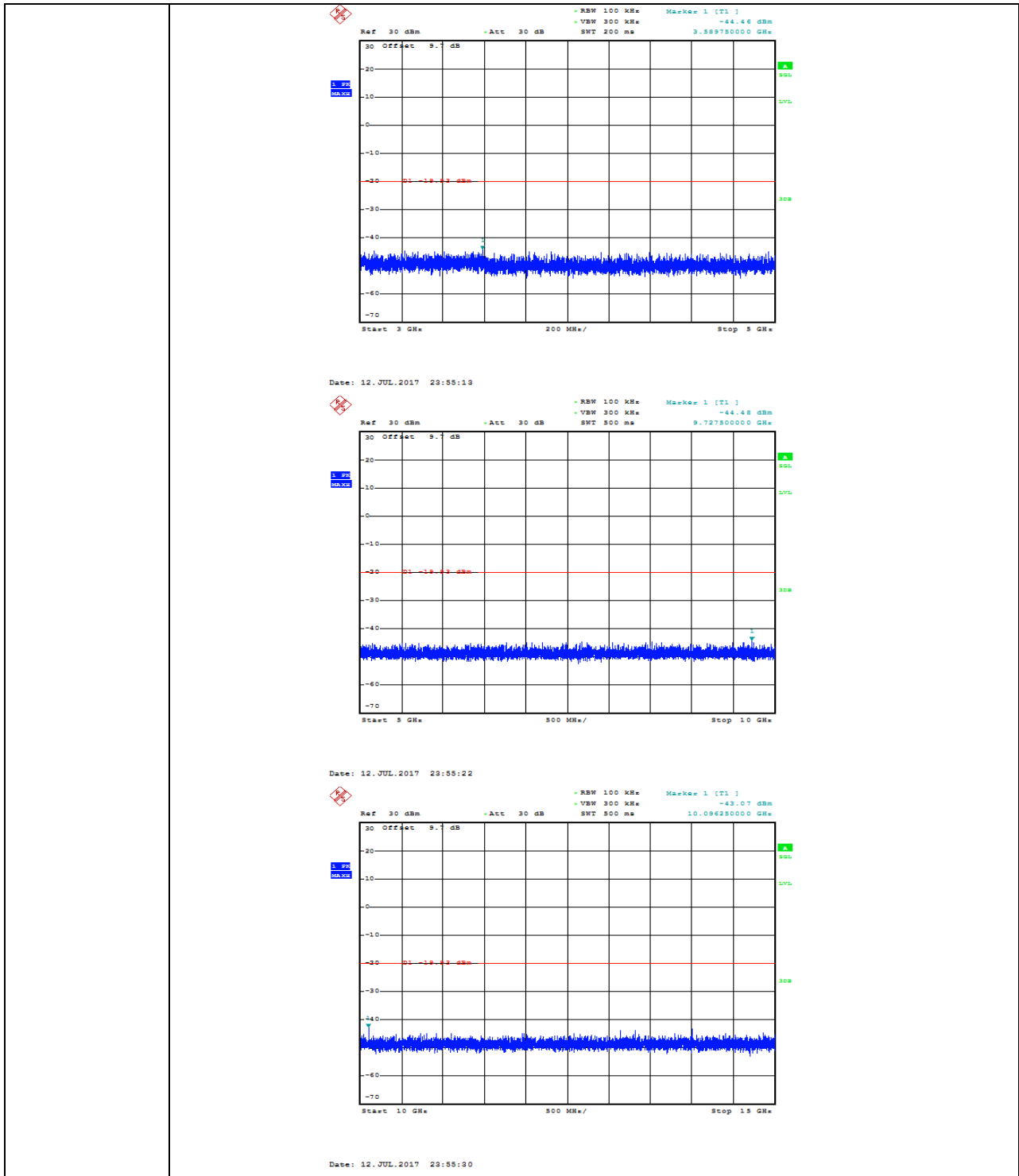

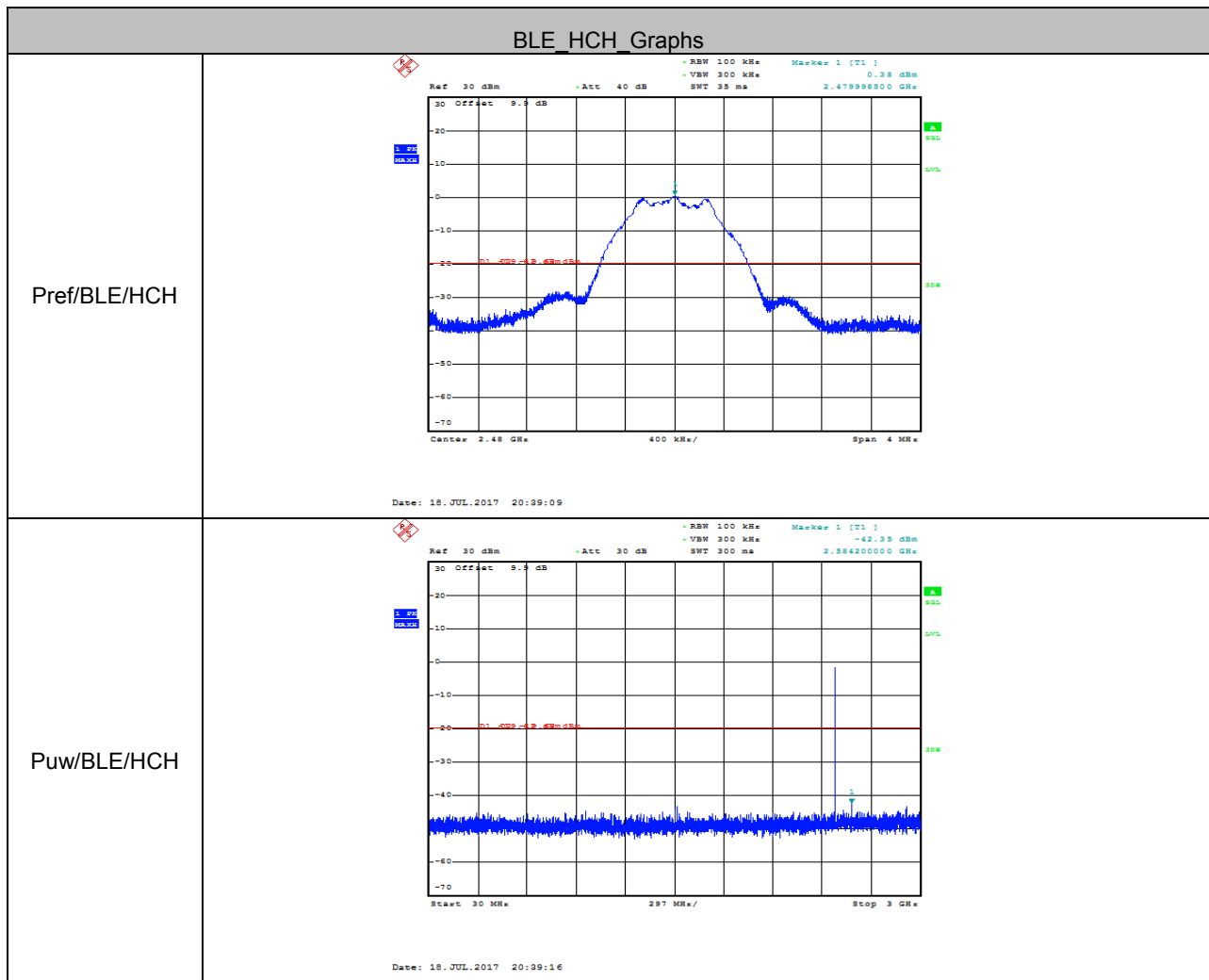
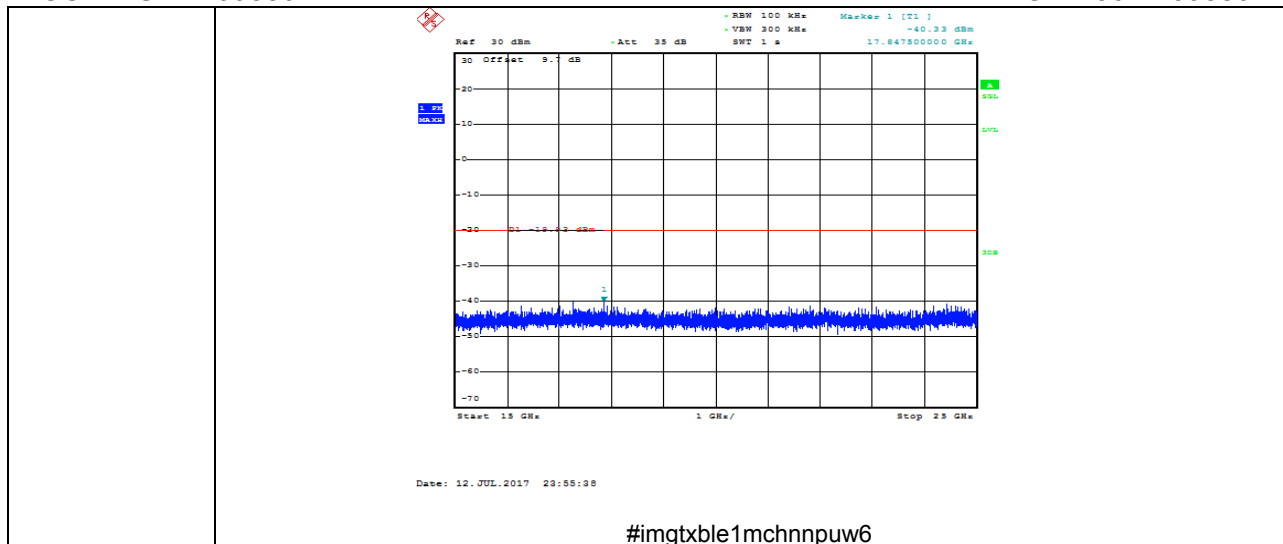

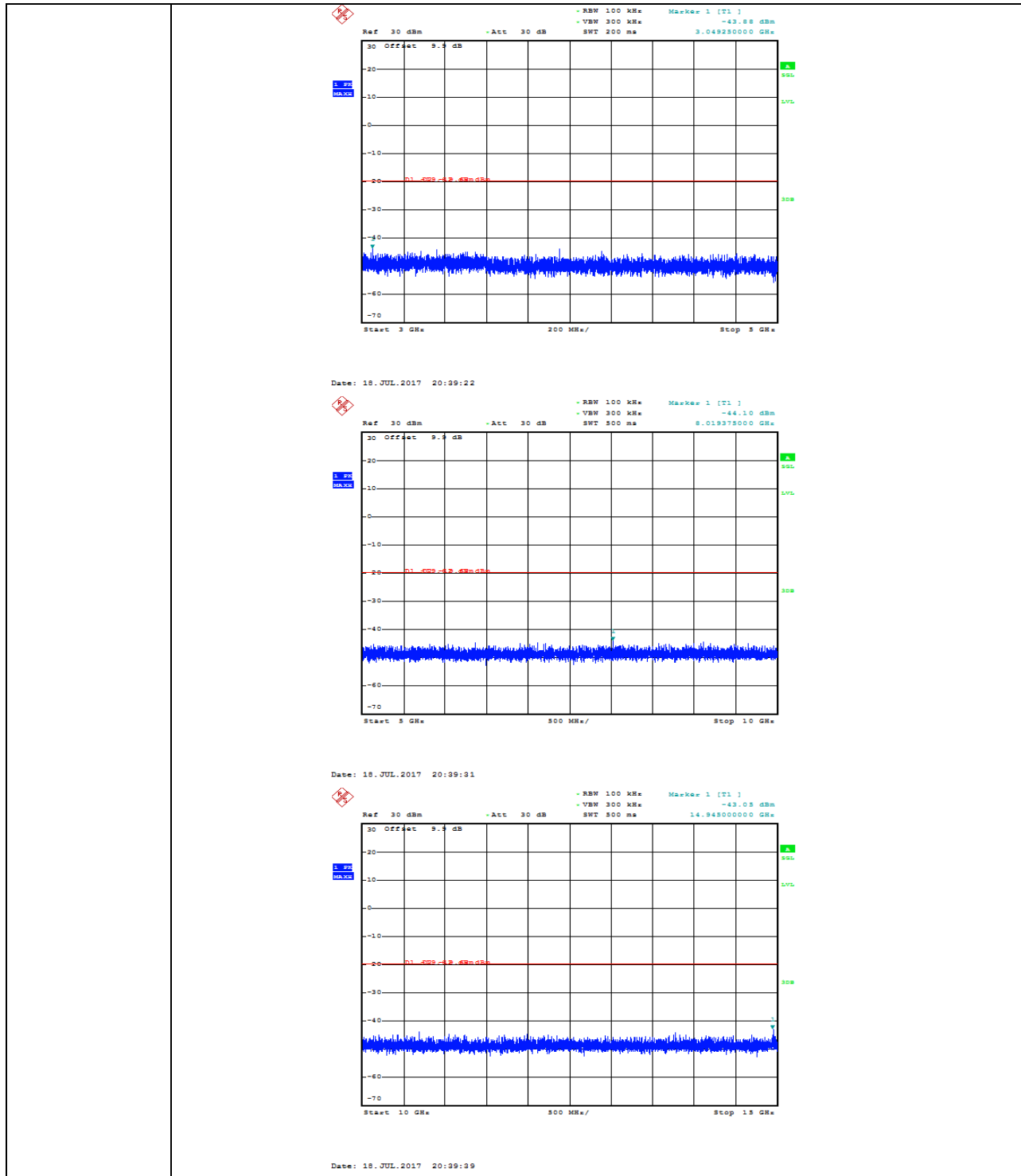

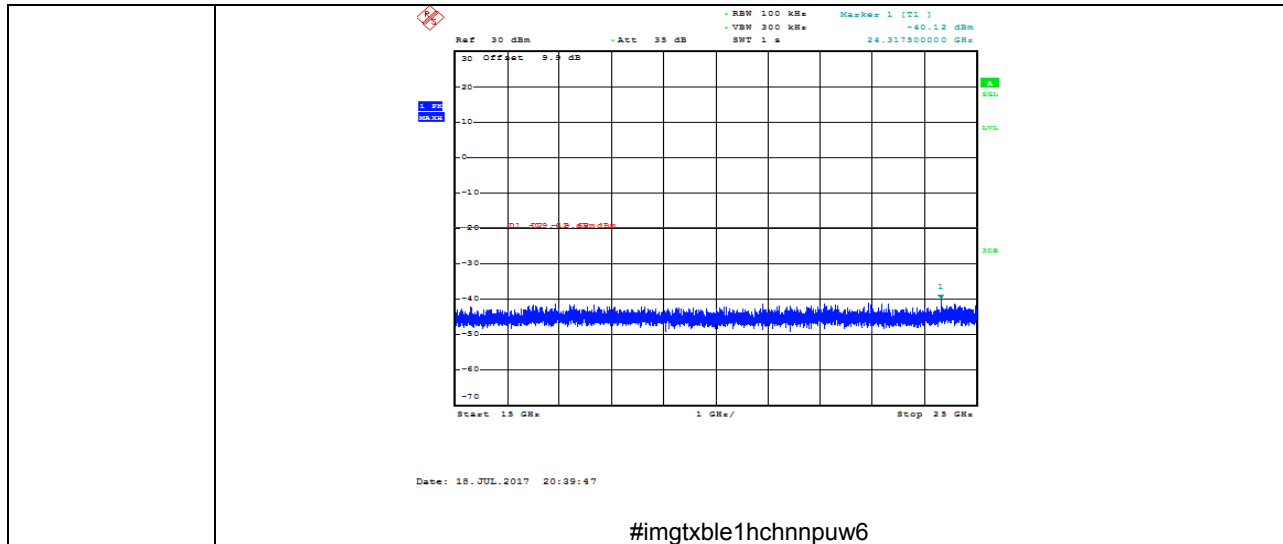

7. RADIATED TEST RESULTS

7.1. LIMITS AND PROCEDURE

LIMITS

Please refer to FCC §15.205 and §15.209

Please refer to IC RSS-GEN Clause 8.9 (Transmitter)

Radiation Disturbance Test Limit for FCC (Class B)(9KHz-1GHz)

Frequency (MHz)	Field Strength (microvolts/meter)	Measurement Distance (meters)
0.009~0.490	2400/F(KHz)	300
0.490~1.705	24000/F(KHz)	30
1.705~30.0	30	30
30~88	100	3
88~216	150	3
216~960	200	3
960~1000	500	3

Radiation Disturbance Test Limit for FCC (Above 1G)

Frequency (MHz)	dB(uV/m) (at 3 meters)	
	Peak	Average
Above 1000	74	54

TEST SETUP AND PROCEDURE

Below 30MHz

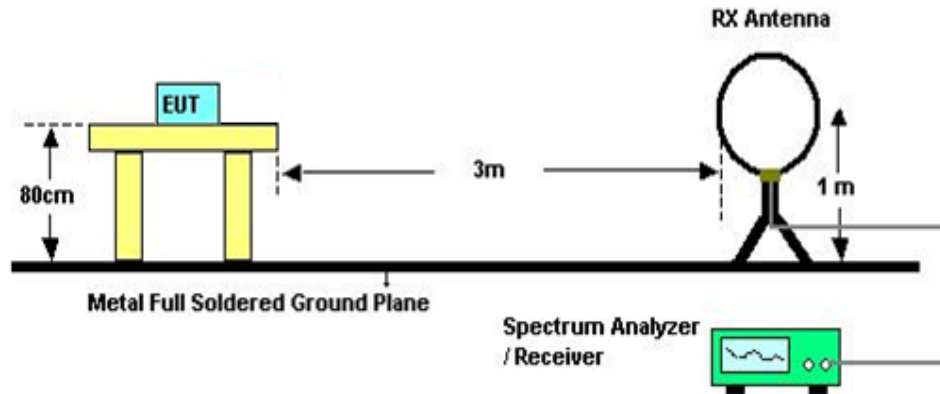

The setting of the spectrum analyser

RBW	200Hz (From 9kHz to 0.15MHz)/ 9KHz (From 0.15MHz to 30MHz)
VBW	200Hz (From 9kHz to 0.15MHz)/ 9KHz (From 0.15MHz to 30MHz)
Sweep	Auto
Detector	Peak/QP/ Average
Trace	Max hold

1. The testing follows the guidelines in ANSI C63.10-2013
2. The EUT was arranged to its worst case and then turntable (from 0 degree to 360 degrees) to find the maximum reading. A pre-amp and a high pass filter are used for the test in order to get better signal level. Both horizontal and vertical polarizations of the antenna are set to make the measurement.
3. The EUT was placed on a turntable with 0.8 meter above ground.
4. The EUT was set 3 meters from the interference receiving antenna, which was mounted on the top of a variable height antenna tower.
5. Corrected Reading: Antenna Factor + Cable Loss + Read Level - Preamp Factor = Level
6. For measurement below 1GHz, the initial step in collecting conducted emission data is a spectrum analyzer peak detector mode pre-scanning the measurement frequency range. Significant peaks are then marked and then Quasi Peak detector mode re-measured. If the emission level of the EUT measured by the peak detector is 3 dB lower than the applicable limit, the peak emission level will be reported. Otherwise, the emission measurement will be repeated using the quasi-peak detector and reported.
7. For the actual test configuration, please refer to the related item in this test report (Photographs of the Test Configuration)

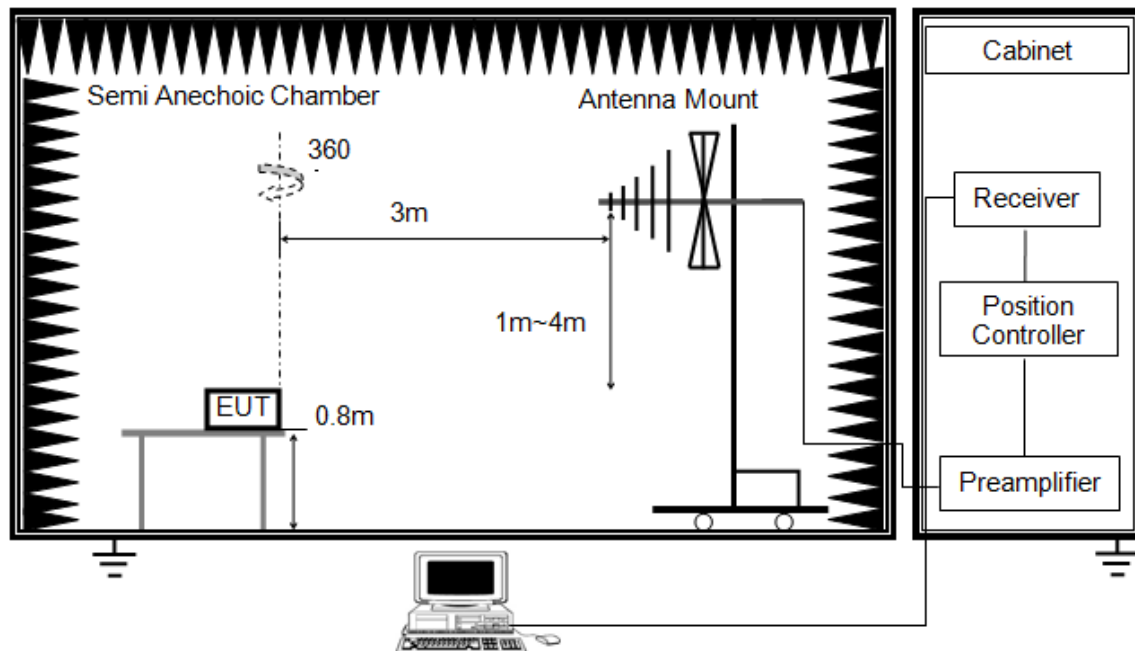

The setting of the spectrum analyser

RBW	120K
VBW	300K
Sweep	Auto
Detector	Peak/QP
Trace	Max hold

1. The testing follows the guidelines in ANSI C63.10-2013.
2. The EUT was arranged to its worst case and then tune the antenna tower (from 1 m to 4 m) and turntable (from 0 degree to 360 degrees) to find the maximum reading. A pre-amp and a high pass filter are used for the test in order to get better signal level. Both horizontal and vertical polarizations of the antenna are set to make the measurement.
3. The EUT was placed on a turntable with 0.8 meter above ground.
4. The EUT was set 3 meters from the interference receiving antenna, which was mounted on the top of a variable height antenna tower.
5. Corrected Reading: $\text{Antenna Factor} + \text{Cable Loss} + \text{Read Level} - \text{Preamp Factor} = \text{Level}$
6. For measurement below 1GHz, the initial step in collecting conducted emission data is a spectrum analyzer peak detector mode pre-scanning the measurement frequency range. Significant peaks are then marked and then Quasi Peak detector mode re-measured. If the emission level of the EUT measured by the peak detector is 3 dB lower than the applicable limit, the peak emission level will be reported. Otherwise, the emission measurement will be repeated using the quasi-peak detector and reported.
7. For the actual test configuration, please refer to the related Item in this test report (Photographs of the Test Configuration)

ABOVE 1G

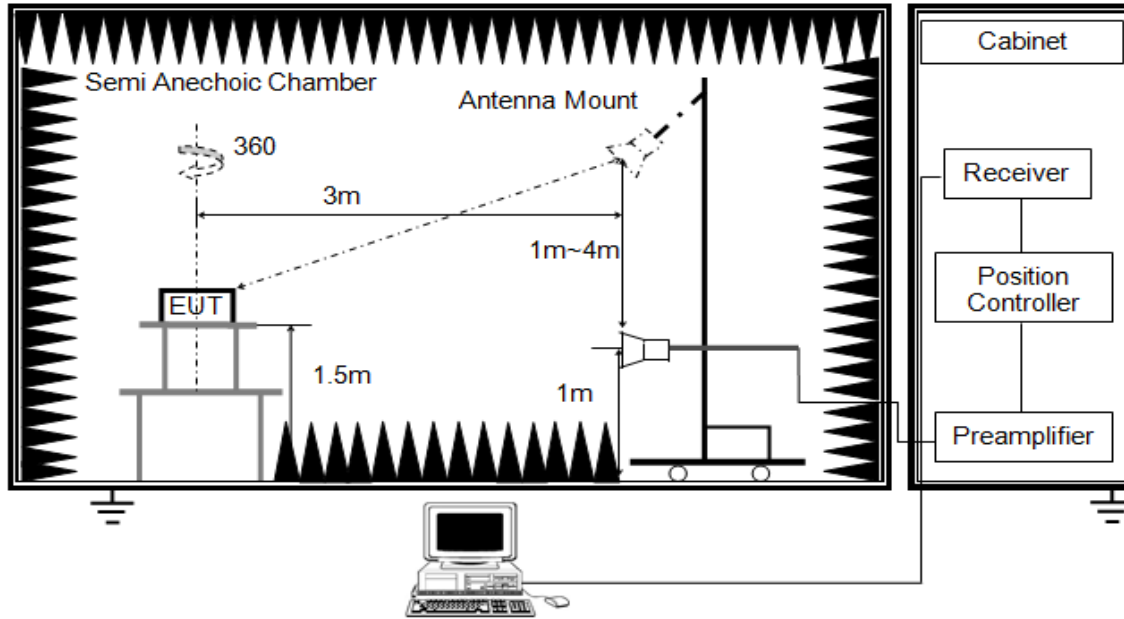

The setting of the spectrum analyser

RBW	1M
VBW	3M
Sweep	Auto
Detector	Peak and CISPR Average
Trace	Max hold

1. The testing follows the guidelines in ANSI C63.10-2013.
2. The EUT was arranged to its worst case and then tune the antenna tower (from 1 m to 4 m) and turntable (from 0 degree to 360 degrees) to find the maximum reading. A pre-amp and a high pass filter are used for the test in order to get better signal level. Both horizontal and vertical polarizations of the antenna are set to make the measurement.
3. The EUT was placed on a turntable with 1.5m above ground.
4. The EUT was set 3 meters from the interference receiving antenna, which was mounted on the top of a variable height antenna tower.
5. For measurement above 1GHz, the emission measurement will be measured by the peak detector. This peak level, once corrected, must comply with the limit specified in Section 15.209.
6. For average power measurement, set the VBW to 10 Hz, while maintaining all of the other instrument settings, if the duty cycle of the EUT is less than 98%, the Duty Cycle Correction Factor shall be added to the measured emission levels. For the Duty Cycle and Correction Factor please refer to clause 6.1.ON TIME AND DUTY CYCLE.
8. For the actual test configuration, please refer to the related item in this test report (Photographs of the Test Configuration)

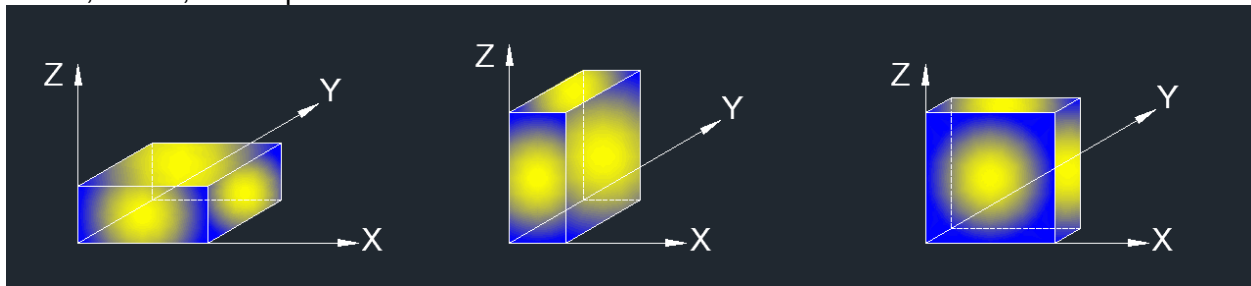

7.2. RESTRICTED BANDEDGE

RESTRICTED BANDEDGE (LOW CHANNEL, HORIZONTAL)

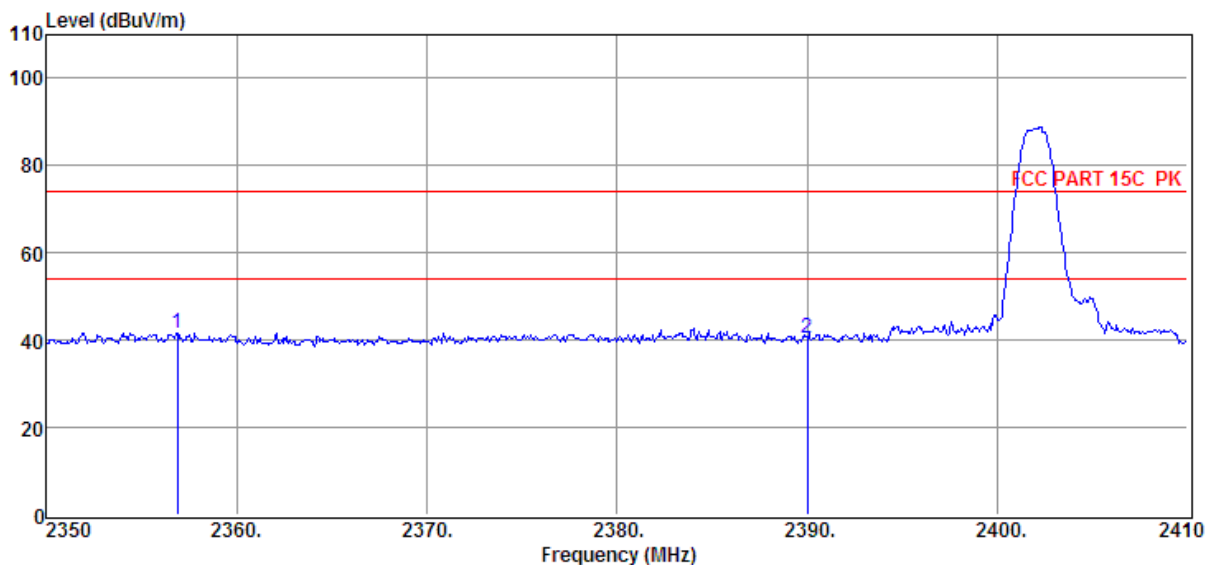

Item (Mark)	Freq. (MHz)	Read Level (dB μ V)	Antenna Factor (dB/m)	PRM Factor (dB)	Cable Loss (dB)	Result Level (dB μ V/m)	Limit Line (dB μ V/m)	Over Limit (dB)	Detector
1	2356.90	35.39	29.65	29.34	5.96	41.66	74.00	-32.34	Peak
2	2390.00	34.02	29.78	29.42	6.03	40.41	74.00	-33.59	Peak

- Note: 1. Result Level = Read Level + Antenna Factor + Cable loss - PRM Factor.
 2. If Peak Result complies with AV limit, AV Result is deemed to comply with AV limit.
 3. Test setup: RBW: 1 MHz, VBW: 3 MHz, Sweep time: auto.

RESTRICTED BANDEDGE (LOW CHANNEL, VERTICAL)

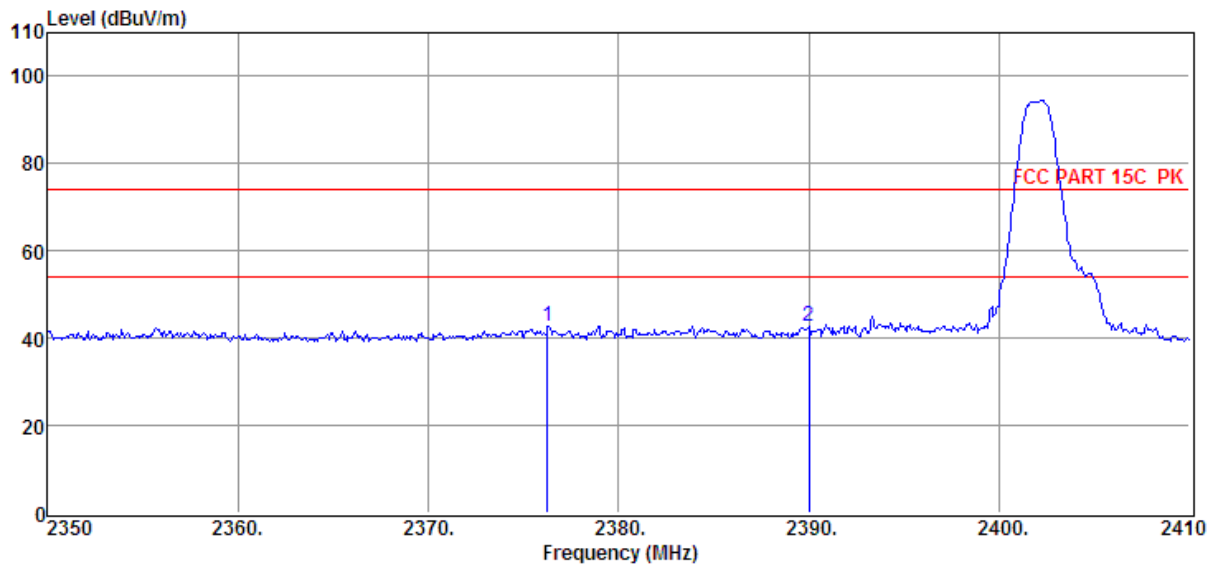

Item (Mark)	Freq. (MHz)	Read Level (dBμV)	Antenna Factor (dB/m)	PRM Factor (dB)	Cable Loss (dB)	Result Level (dBμV/m)	Limit Line (dBμV/m)	Over Limit (dB)	Detector
1	2376.28	36.31	29.72	29.39	6.01	42.65	74.00	-31.35	Peak
2	2390.00	36.36	29.78	29.42	6.03	42.75	74.00	-31.25	Peak

- Note: 1. Result Level = Read Level + Antenna Factor + Cable loss - PRM Factor.
 2. If Peak Result complies with AV limit, AV Result is deemed to comply with AV limit.
 3. Test setup: RBW: 1 MHz, VBW: 3 MHz, Sweep time: auto.

RESTRICTED BANDEDGE (HIGH CHANNEL, HORIZONTAL)

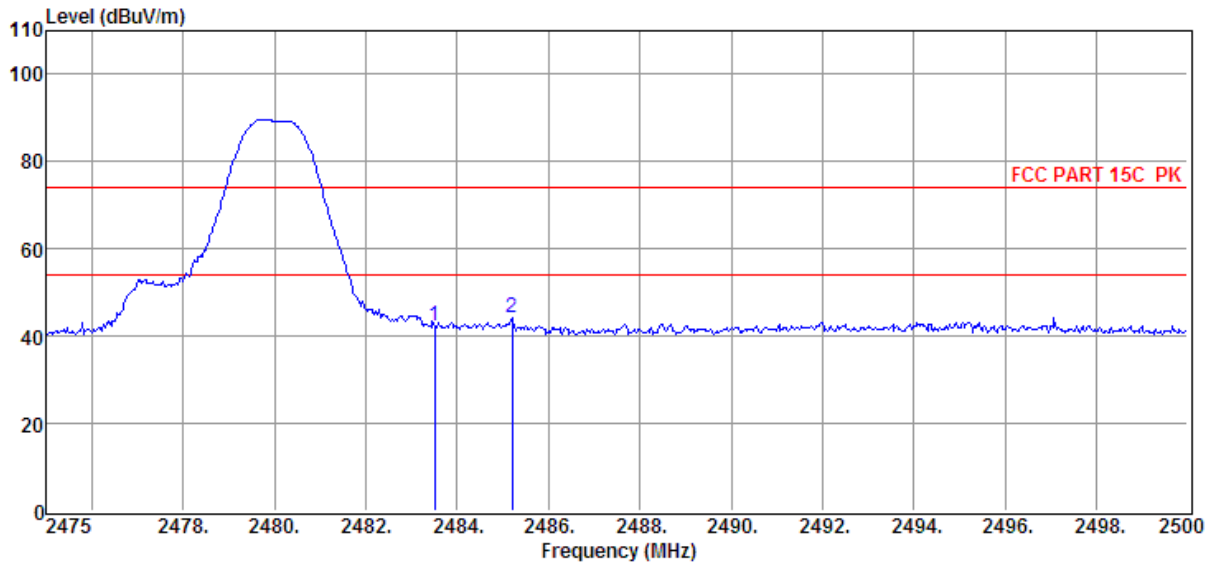

Item (Mark)	Freq. (MHz)	Read Level (dBμV)	Antenna Factor (dB/m)	PRM Factor (dB)	Cable Loss (dB)	Result Level (dBμV/m)	Limit Line (dBμV/m)	Over Limit (dB)	Detector
1	2483.50	35.91	30.14	29.71	6.13	42.47	74.00	-31.53	Peak
2	2485.20	37.84	30.14	29.71	6.13	44.40	74.00	-29.60	Peak

Note: 1. Result Level = Read Level + Antenna Factor + Cable loss - PRM Factor.
 2. If Peak Result complies with AV limit, AV Result is deemed to comply with AV limit.
 3. Test setup: RBW: 1 MHz, VBW: 3 MHz, Sweep time: auto.

RESTRICTED BANDEDGE (HIGH CHANNEL, VERTICAL)

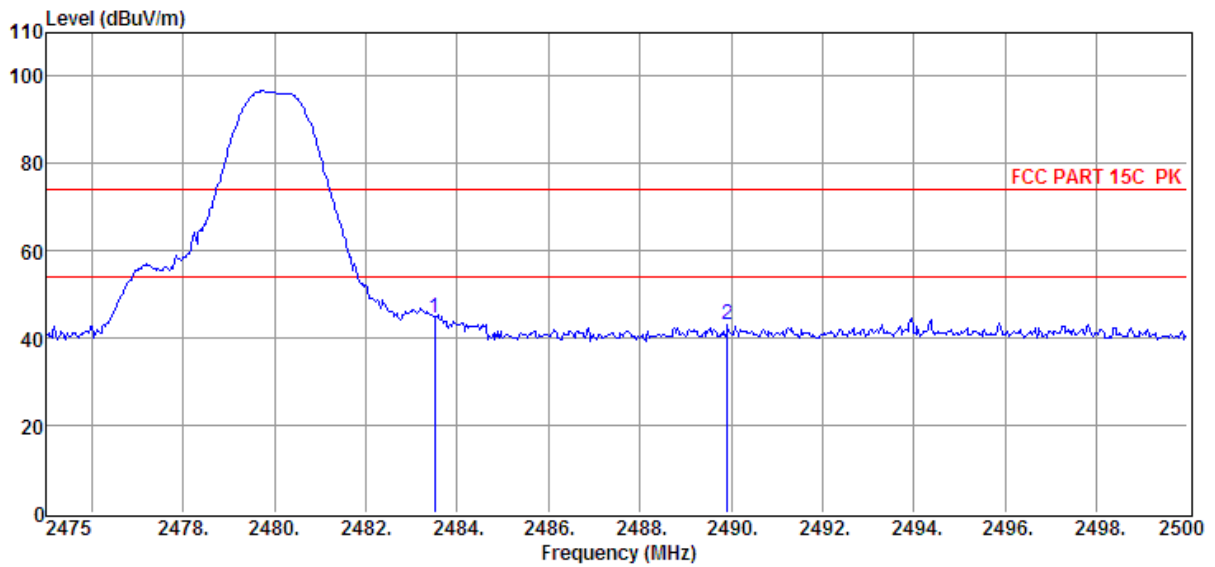

Item (Mark)	Freq. (MHz)	Read Level (dBμV)	Antenna Factor (dB/m)	PRM Factor (dB)	Cable Loss (dB)	Result Level (dBμV/m)	Limit Line (dBμV/m)	Over Limit (dB)	Detector
1	2483.50	38.23	30.14	29.71	6.13	44.79	74.00	-29.21	Peak
2	2489.93	36.39	30.16	29.71	6.17	43.01	74.00	-30.99	Peak

- Note: 1. Result Level = Read Level + Antenna Factor + Cable loss - PRM Factor.
 2. If Peak Result complies with AV limit, AV Result is deemed to comply with AV limit.
 3. Test setup: RBW: 1 MHz, VBW: 3 MHz, Sweep time: auto.

Note: EUT in each of three orthogonal axis emissions had been tested, but only the worst case (X axis) data recorded in the report.

7.3. SPURIOUS EMISSIONS (1~25GHz)

HARMONICS AND SPURIOUS EMISSIONS

EUT:	Bluetooth Headphone	Polarization :	Horizontal
Test Mode:	Low Chanel		

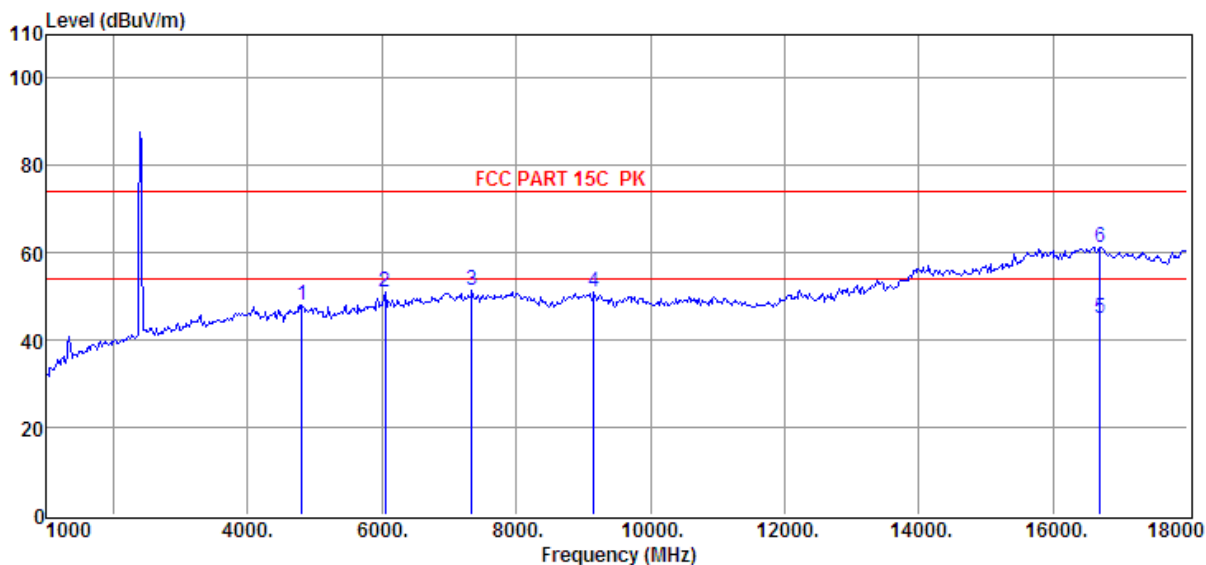

Item (Mark)	Freq. (MHz)	Read Level (dBμV)	Antenna Factor (dB/m)	PRM Factor dB	Cable Loss dB	Result Level (dBμV/m)	Limit Line (dBμV/m)	Over Limit (dB)	Detector
1	4804.00	35.05	33.74	29.32	8.46	47.93	74.00	-26.07	Peak
2	6049.00	35.48	35.08	29.23	9.71	51.04	74.00	-22.96	Peak
3	7341.00	34.80	36.48	30.59	10.72	51.41	74.00	-22.59	Peak
4	9160.00	34.42	37.14	32.39	12.01	51.18	74.00	-22.82	Peak
5	16691.00	18.97	44.39	36.28	17.84	44.92	54.00	-9.08	Average
6	16691.00	35.40	44.39	36.28	17.84	61.35	74.00	-12.65	Peak

Note: 1. Result Level = Read Level + Antenna Factor + Cable loss - PRM Factor.
 2. If Peak Result complies with AV limit, AV Result is deemed to comply with AV limit.
 3. Test setup: RBW: 1 MHz, VBW: 3 MHz, Sweep time: auto.

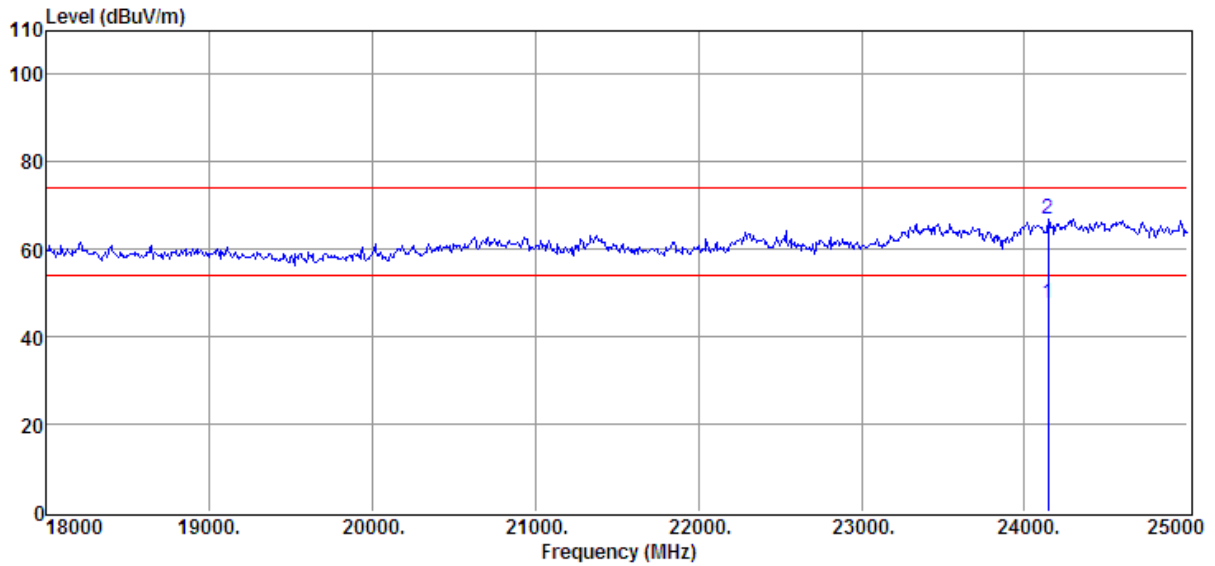

Item (Mark)	Freq. (MHz)	Read Level (dB μ V)	Antenna Factor (dB/m)	PRM Factor dB	Cable Loss dB	Result Level (dB μ V/m)	Limit Line (dB μ V/m)	Over Limit (dB)	Detector
1	24146.00	20.78	44.70	37.71	19.72	47.49	54.00	-6.51	Average
2	24146.00	40.15	44.70	37.71	19.72	66.86	74.00	-7.14	Peak

- Note: 1. Result Level = Read Level + Antenna Factor + Cable loss - PRM Factor.
 2. If Peak Result complies with AV limit, AV Result is deemed to comply with AV limit.
 3. Test setup: RBW: 1 MHz, VBW: 3 MHz, Sweep time: auto.

EUT:	Bluetooth Headphone	Polarization :	Vertical
Test Mode:	Low Chanel		

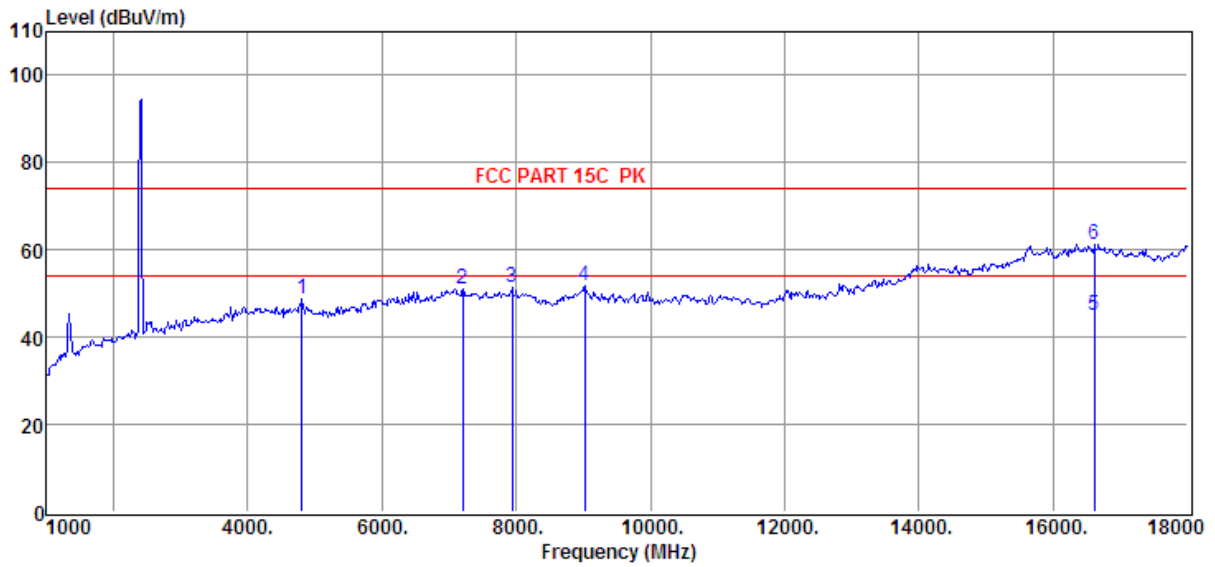

Item (Mark)	Freq. (MHz)	Read Level (dBμV)	Antenna Factor (dB/m)	PRM Factor (dB)	Cable Loss (dB)	Result Level (dBμV/m)	Limit Line (dBμV/m)	Over Limit (dB)	Detector
1	4804.00	36.05	33.74	29.32	8.46	48.93	74.00	-25.07	Peak
2	7205.00	34.60	36.37	30.49	10.60	51.08	74.00	-22.92	Peak
3	7936.00	34.74	36.69	31.11	11.10	51.42	74.00	-22.58	Peak
4	9024.00	34.93	37.45	32.33	11.83	51.88	74.00	-22.12	Peak
5	16606.00	18.84	44.53	36.21	17.71	44.87	54.00	-9.13	Average
6	16606.00	35.37	44.53	36.21	17.71	61.40	74.00	-12.60	Peak

Note: 1. Result Level = Read Level + Antenna Factor + Cable loss - PRM Factor.
 2. If Peak Result complies with AV limit, AV Result is deemed to comply with AV limit.
 3. Test setup: RBW: 1 MHz, VBW: 3 MHz, Sweep time: auto.

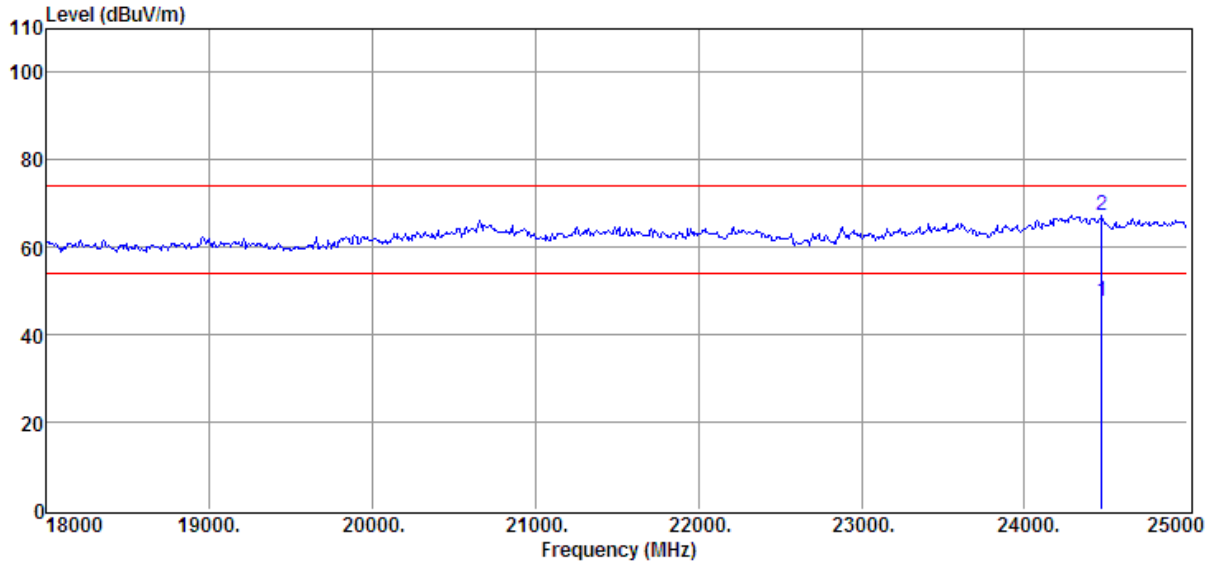

Item (Mark)	Freq. (MHz)	Read Level (dBμV)	Antenna Factor (dB/m)	PRM Factor dB	Cable Loss dB	Result Level (dBμV/m)	Limit Line (dBμV/m)	Over Limit (dB)	Detector
1	24475.00	20.78	44.70	37.71	19.72	47.49	54.00	-6.51	Average
2	24475.00	40.43	44.70	37.71	19.72	67.14	74.00	-6.86	Peak

- Note: 1. Result Level = Read Level + Antenna Factor + Cable loss - PRM Factor.
 2. If Peak Result complies with AV limit, AV Result is deemed to comply with AV limit.
 3. Test setup: RBW: 1 MHz, VBW: 3 MHz, Sweep time: auto.

EUT:	Bluetooth Headphone	Polarization :	Horizontal
Test Mode:	Middle Chanel		

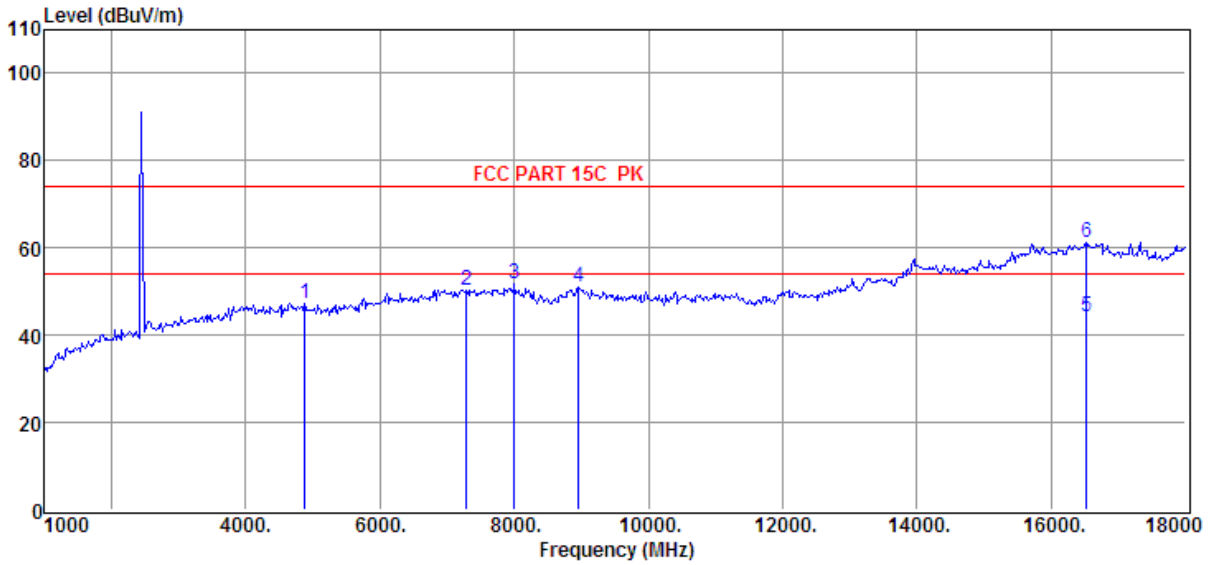

Item (Mark)	Freq. (MHz)	Read Level (dBμV)	Antenna Factor (dB/m)	PRM Factor (dB)	Cable Loss (dB)	Result Level (dBμV/m)	Limit Line (dBμV/m)	Over Limit (dB)	Detector
1	4880.00	34.31	33.72	29.33	8.56	47.26	74.00	-26.74	Peak
2	7290.00	33.77	36.44	30.55	10.68	50.34	74.00	-23.66	Peak
3	8004.00	35.19	36.69	31.13	11.13	51.88	74.00	-22.12	Peak
4	8956.00	34.05	37.31	32.28	11.79	50.87	74.00	-23.13	Peak
5	16521.00	18.06	44.67	36.06	17.51	44.18	54.00	-9.82	Average
6	16521.00	35.12	44.67	36.06	17.51	61.24	74.00	-12.76	Peak

Note: 1. Result Level = Read Level + Antenna Factor + Cable loss - PRM Factor.
 2. If Peak Result complies with AV limit, AV Result is deemed to comply with AV limit.
 3. Test setup: RBW: 1 MHz, VBW: 3 MHz, Sweep time: auto.

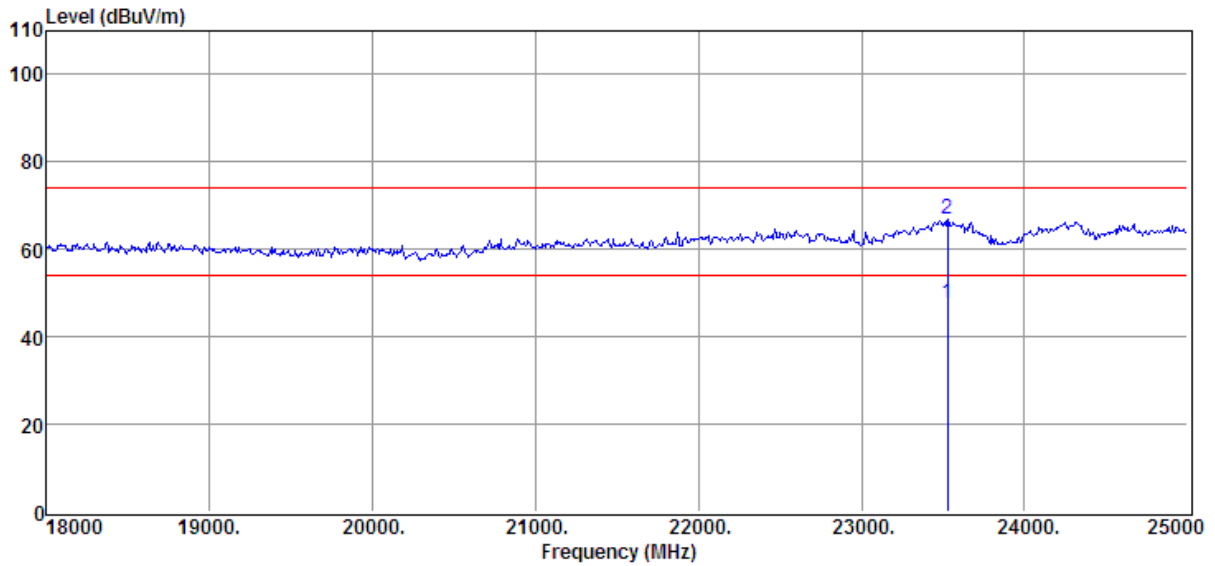

Item (Mark)	Freq. (MHz)	Read Level (dBμV)	Antenna Factor (dB/m)	PRM Factor dB	Cable Loss dB	Result Level (dBμV/m)	Limit Line (dBμV/m)	Over Limit (dB)	Detector
1	23530.00	21.00	44.70	37.71	19.72	47.71	54.00	-6.29	Average
2	23530.00	40.02	44.70	37.71	19.72	66.73	74.00	-7.27	Peak

Note: 1. Result Level = Read Level + Antenna Factor + Cable loss - PRM Factor.
 2. If Peak Result complies with AV limit, AV Result is deemed to comply with AV limit.
 3. Test setup: RBW: 1 MHz, VBW: 3 MHz, Sweep time: auto.

EUT:	Bluetooth Headphone	Polarization :	Vertical
Test Mode:	Middle Chanel		

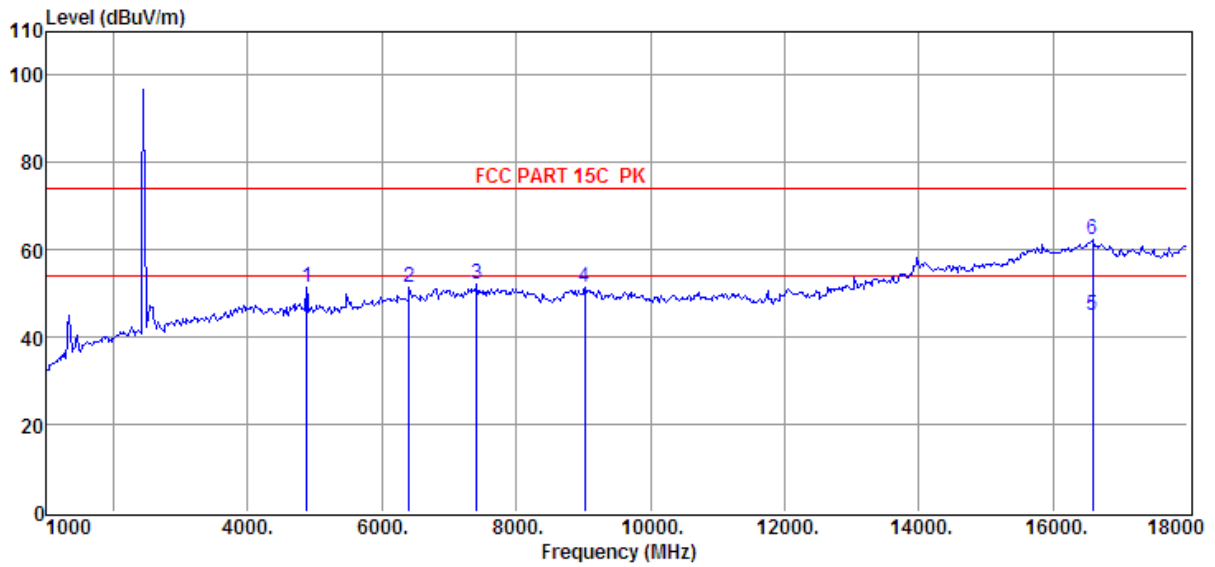

Item (Mark)	Freq. (MHz)	Read Level (dBμV)	Antenna Factor (dB/m)	PRM Factor (dB)	Cable Loss (dB)	Result Level (dBμV/m)	Limit Line (dBμV/m)	Over Limit (dB)	Detector
1	4880.00	38.59	33.72	29.33	8.56	51.54	74.00	-22.46	Peak
2	6406.00	35.35	35.65	29.66	9.88	51.22	74.00	-22.78	Peak
3	7409.00	35.50	36.53	30.67	10.78	52.14	74.00	-21.86	Peak
4	9024.00	34.37	37.45	32.33	11.83	51.32	74.00	-22.68	Peak
5	16589.00	19.06	44.56	36.21	17.64	45.05	54.00	-8.95	Average
6	16589.00	36.28	44.56	36.21	17.64	62.27	74.00	-11.73	Peak

Note: 1. Result Level = Read Level + Antenna Factor + Cable loss - PRM Factor.
 2. If Peak Result complies with AV limit, AV Result is deemed to comply with AV limit.
 3. Test setup: RBW: 1 MHz, VBW: 3 MHz, Sweep time: auto.

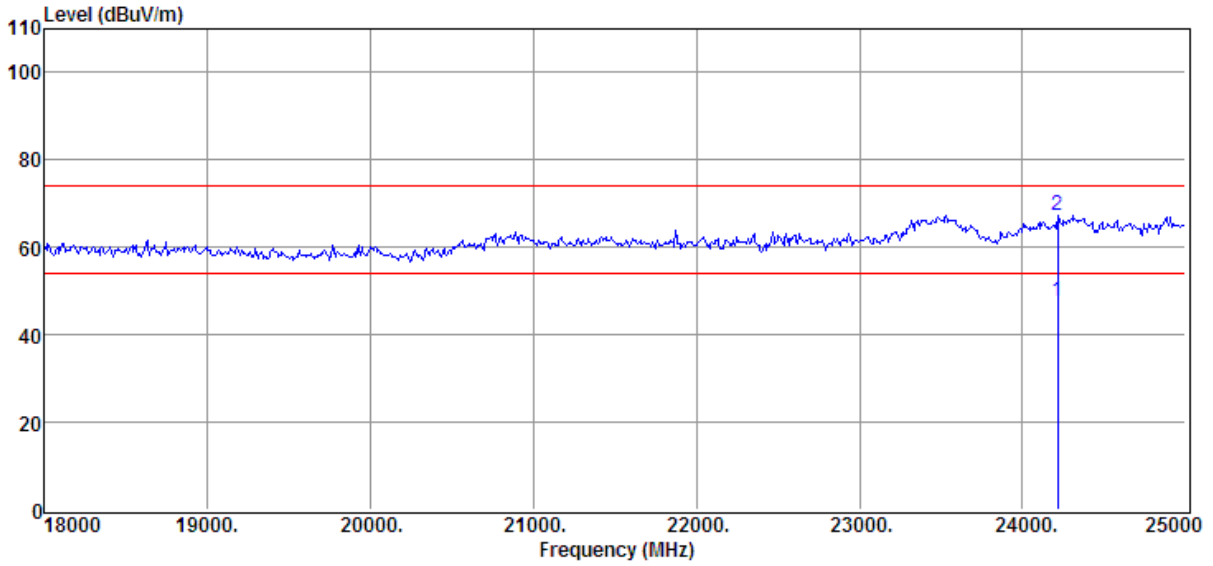

Item (Mark)	Freq. (MHz)	Read Level (dBμV)	Antenna Factor (dB/m)	PRM Factor dB	Cable Loss dB	Result Level (dBμV/m)	Limit Line (dBμV/m)	Over Limit (dB)	Detector
1	24216.00	20.78	44.70	37.71	19.72	47.49	54.00	-6.51	Average
2	24216.00	40.65	44.70	37.71	19.72	67.36	74.00	-6.64	Peak

- Note: 1. Result Level = Read Level + Antenna Factor + Cable loss - PRM Factor.
 2. If Peak Result complies with AV limit, AV Result is deemed to comply with AV limit.
 3. Test setup: RBW: 1 MHz, VBW: 3 MHz, Sweep time: auto.

EUT:	Bluetooth Headphone	Polarization :	Horizontal
Test Mode:	High Chanel		

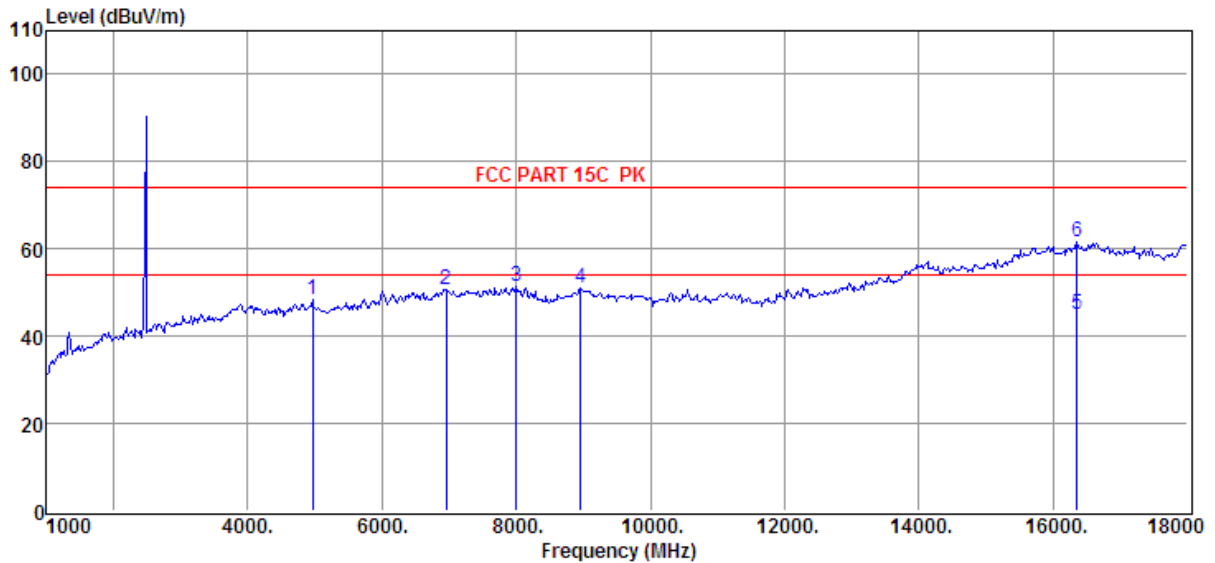

Item (Mark)	Freq. (MHz)	Read Level (dBμV)	Antenna Factor (dB/m)	PRM Factor (dB)	Cable Loss (dB)	Result Level (dBμV/m)	Limit Line (dBμV/m)	Over Limit (dB)	Detector
1	4960.00	35.42	33.71	29.35	8.63	48.41	74.00	-25.59	Peak
2	6950.00	34.43	36.16	30.34	10.39	50.64	74.00	-23.36	Peak
3	8004.00	34.72	36.69	31.13	11.13	51.41	74.00	-22.59	Peak
4	8956.00	34.21	37.31	32.28	11.79	51.03	74.00	-22.97	Peak
5	16351.00	18.99	44.46	35.86	17.38	44.97	54.00	-9.03	Average
6	16351.00	35.56	44.46	35.86	17.38	61.54	74.00	-12.46	Peak

Note: 1. Result Level = Read Level + Antenna Factor + Cable loss - PRM Factor.
 2. If Peak Result complies with AV limit, AV Result is deemed to comply with AV limit.
 3. Test setup: RBW: 1 MHz, VBW: 3 MHz, Sweep time: auto.

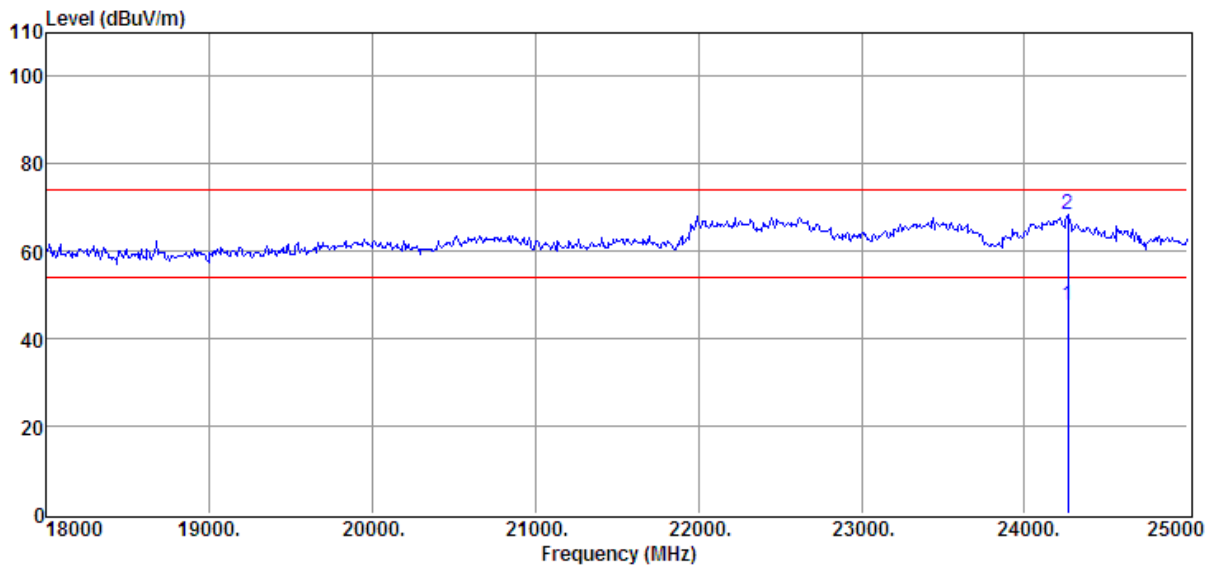

Item (Mark)	Freq. (MHz)	Read Level (dB μ V)	Antenna Factor (dB/m)	PRM Factor dB	Cable Loss dB	Result Level (dB μ V/m)	Limit Line (dB μ V/m)	Over Limit (dB)	Detector
1	24265.00	20.78	44.70	37.71	19.72	47.49	54.00	-6.51	Average
2	24265.00	41.57	44.70	37.71	19.72	68.28	74.00	-5.72	Peak

- Note: 1. Result Level = Read Level + Antenna Factor + Cable loss - PRM Factor.
 2. If Peak Result complies with AV limit, AV Result is deemed to comply with AV limit.
 3. Test setup: RBW: 1 MHz, VBW: 3 MHz, Sweep time: auto.

EUT:	Bluetooth Headphone	Polarization :	Vertical
Test Mode:	High Chanel		

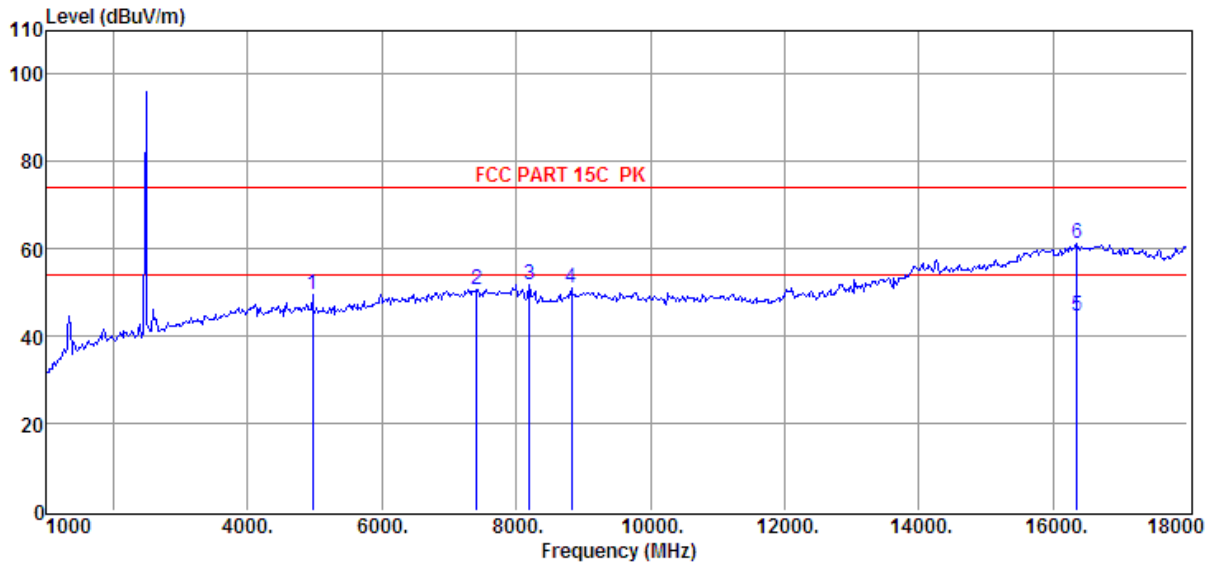

Item (Mark)	Freq. (MHz)	Read Level (dBμV)	Antenna Factor (dB/m)	PRM Factor dB	Cable Loss dB	Result Level (dBμV/m)	Limit Line (dBμV/m)	Over Limit (dB)	Detector
1	4960.00	36.46	33.71	29.35	8.63	49.45	74.00	-24.55	Peak
2	7409.00	34.02	36.53	30.67	10.78	50.66	74.00	-23.34	Peak
3	8191.00	35.48	36.16	31.29	11.33	51.68	74.00	-22.32	Peak
4	8820.00	34.86	36.72	32.18	11.75	51.15	74.00	-22.85	Peak
5	16351.00	18.66	44.46	35.86	17.38	44.64	54.00	-9.36	Average
6	16351.00	35.39	44.46	35.86	17.38	61.37	74.00	-12.63	Peak

Note: 1. Result Level = Read Level + Antenna Factor + Cable loss - PRM Factor.
 2. If Peak Result complies with AV limit, AV Result is deemed to comply with AV limit.
 3. Test setup: RBW: 1 MHz, VBW: 3 MHz, Sweep time: auto.

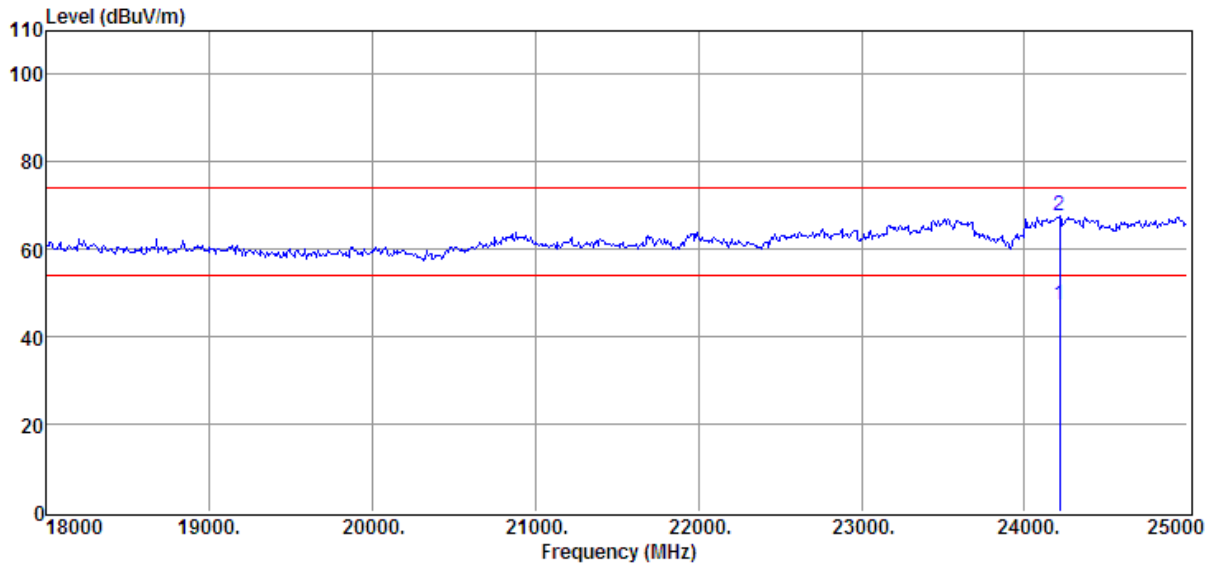

Item (Mark)	Freq. (MHz)	Read Level (dBμV)	Antenna Factor (dB/m)	PRM Factor dB	Cable Loss dB	Result Level (dBμV/m)	Limit Line (dBμV/m)	Over Limit (dB)	Detector
1	24216.00	20.48	44.70	37.71	19.72	47.19	54.00	-6.81	Average
2	24216.00	40.94	44.70	37.71	19.72	67.65	74.00	-6.35	Peak

- Note: 1. Result Level = Read Level + Antenna Factor + Cable loss - PRM Factor.
 2. If Peak Result complies with AV limit, AV Result is deemed to comply with AV limit.
 3. Test setup: RBW: 1 MHz, VBW: 3 MHz, Sweep time: auto.

Note: EUT in each of three orthogonal axis emissions had been tested, but only the worst case (X axis) data recorded in the report.

7.4. SPURIOUS EMISSIONS 30M ~ 1 GHz

SPURIOUS EMISSIONS 30 TO 1000 MHz (WORST-CASE CONFIGURATION)

EUT:	Bluetooth Headphone	Polarization :	Horizontal
Test Mode:	Middle Channel		

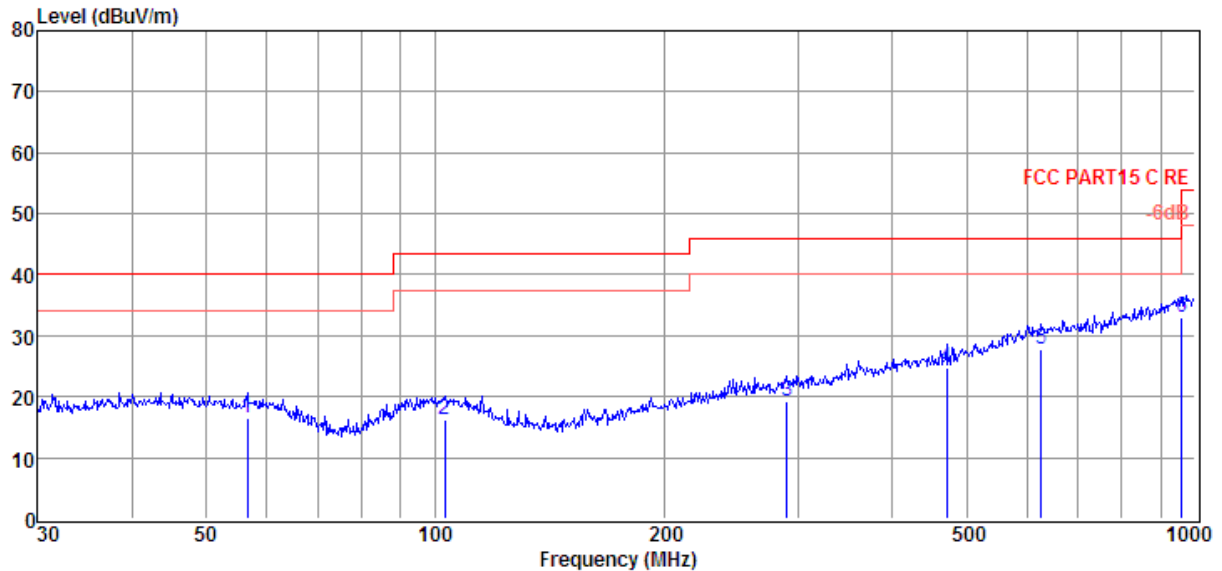

Item	Freq.	Read Level	Antenna Factor	Cable Loss	Result Level	Limit Line	Over Limit	Detector
(Mark)	(MHz)	(dBμV)	(dB/m)	dB	(dBμV/m)	(dBμV/m)	(dB)	
1	56.59	1.00	11.63	3.95	16.58	40.00	-23.42	QP
2	103.08	0.09	11.75	4.32	16.16	43.50	-27.34	QP
3	290.02	0.49	13.50	5.33	19.32	46.00	-26.68	QP
4	470.52	2.01	16.63	6.06	24.70	46.00	-21.30	QP
5	627.27	1.88	19.40	6.60	27.88	46.00	-18.12	QP
6	958.79	2.47	23.06	7.57	33.10	46.00	-12.90	QP

- Note: 1. Result Level = Read Level + Antenna Factor + Cable loss.
 2. If Peak Result complies with QP limit, QP Result is deemed to comply with QP limit.
 3. Test setup: RBW: 120 kHz, VBW: 300 kHz, Sweep time: auto.

EUT:	Bluetooth Headphone	Polarization :	Vertical
Test Mode:	Middle Channel		

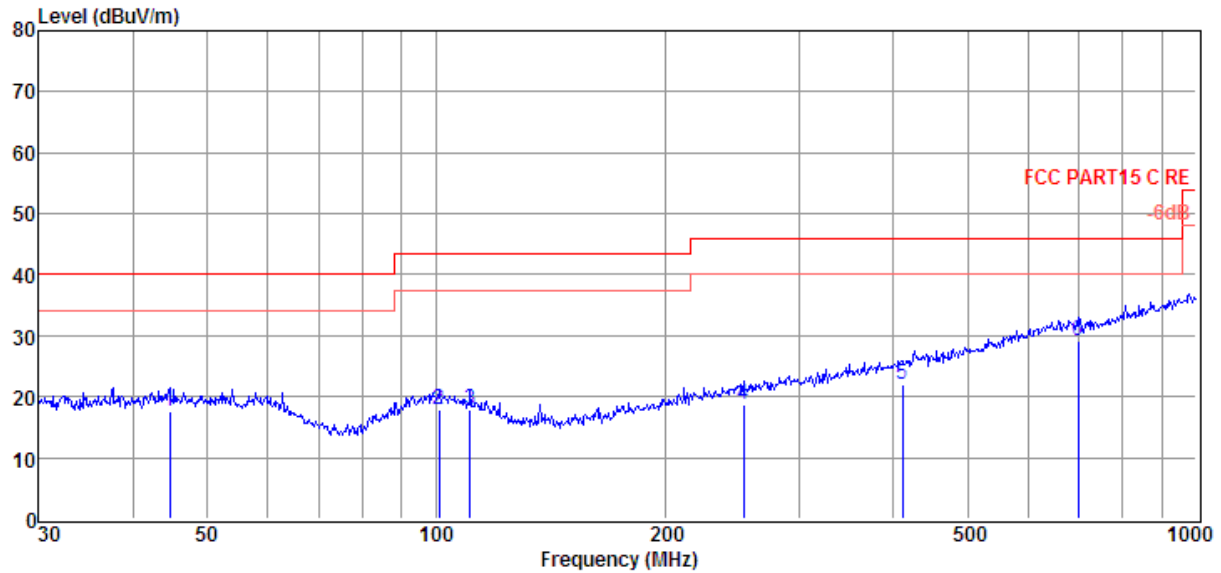

Item	Freq.	Read Level	Antenna Factor	Cable Loss	Result Level	Limit Line	Over Limit	Detector
(Mark)	(MHz)	(dBμV)	(dB/m)	dB	(dBμV/m)	(dBμV/m)	(dB)	
1	44.59	1.34	12.34	3.84	17.52	40.00	-22.48	QP
2	100.93	1.68	11.92	4.31	17.91	43.50	-25.59	QP
3	110.96	2.72	10.88	4.37	17.97	43.50	-25.53	QP
4	253.84	1.12	12.30	5.16	18.58	46.00	-27.42	QP
5	410.38	0.22	15.92	5.84	21.98	46.00	-24.02	QP
6	699.31	2.33	19.89	6.83	29.05	46.00	-16.95	QP

Note: 1. Result Level = Read Level + Antenna Factor + Cable loss.
 2. If Peak Result complies with QP limit, QP Result is deemed to comply with QP limit.
 3. Test setup: RBW: 120 kHz, VBW: 300 kHz, Sweep time: auto

Note 1: All the channels had been tested, but only the worst data recorded in the report.

Note 2: EUT in each of three orthogonal axis emissions had been tested, but only the worst case (X axis) data recorded in the report.

7.5. SPURIOUS EMISSIONS BELOW 30M

SPURIOUS EMISSIONS Below 30MHz (WORST-CASE CONFIGURATION)

EUT:	Bluetooth Headphone	Polarization :	Horizontal
Test Mode:	Middle Channel		

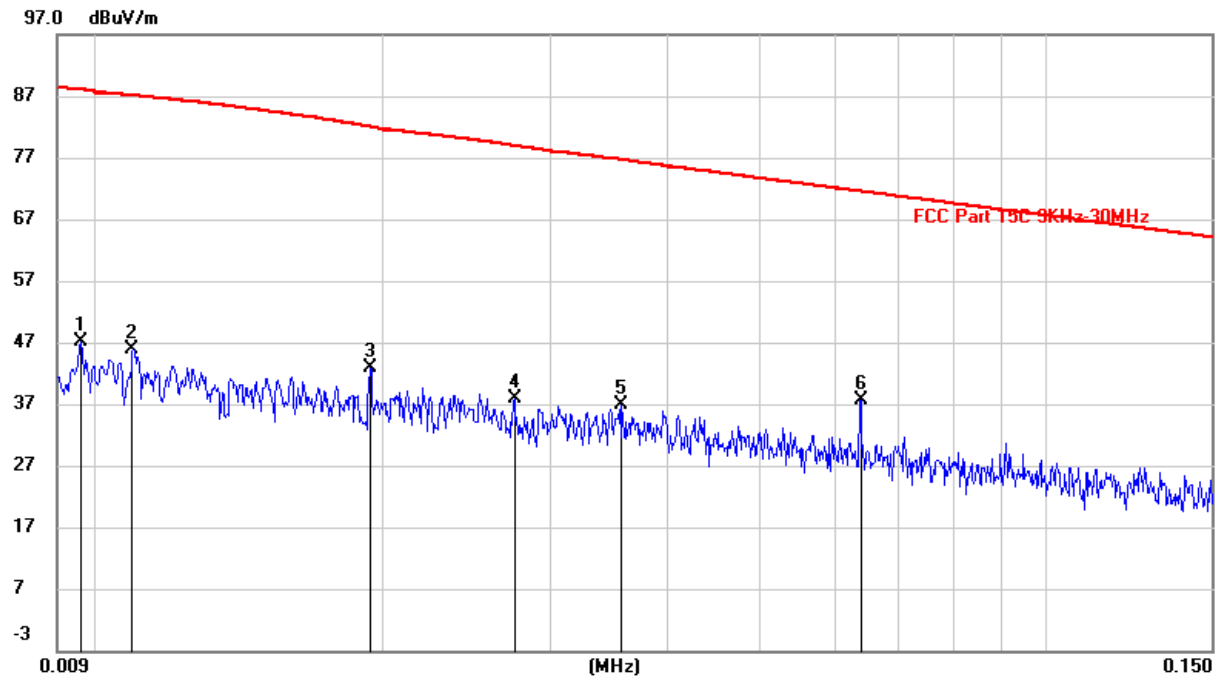

No.	Frequency (KHz)	Reading (dBuV/m)	Correct dB/m	Result (dBuV/m)	Limit (dBuV/m)	Margin (dB)	Remark
1	0.0095	26.90	20.26	47.16	88.02	-40.86	QP
2	0.0108	25.74	20.22	45.96	87.12	-41.16	QP
3	0.0193	22.46	20.30	42.76	82.00	-39.24	QP
4	0.0274	17.60	20.31	37.91	78.98	-41.07	QP
5	0.0355	16.47	20.31	36.78	76.69	-39.91	QP
6	0.0640	17.38	20.31	37.69	71.50	-33.81	QP

EUT:	Bluetooth Headphone	Polarization :	Horizontal
Test Mode:	Middle Channel		

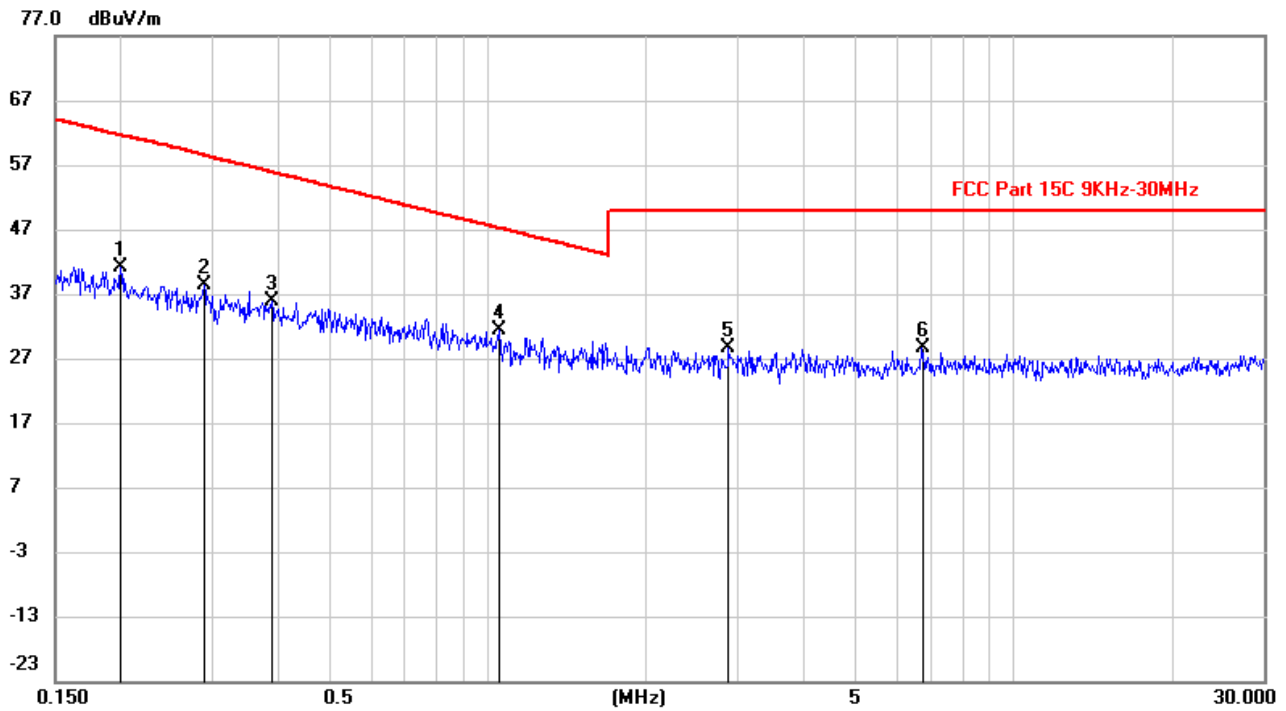

No.	Frequency (MHz)	Reading (dBuV/m)	Correct dB/m	Result (dBuV/m)	Limit (dBuV/m)	Margin (dB)	Remark
1	0.1997	20.85	20.37	41.22	61.59	-20.37	QP
2	0.2878	18.16	20.31	38.47	58.49	-20.02	QP
3	0.3871	15.64	20.28	35.92	55.88	-19.96	QP
4	1.0485	10.89	20.38	31.27	47.20	-15.93	QP
5	2.8692	7.82	20.88	28.70	50.00	-21.30	QP
6	6.6978	7.71	20.90	28.61	50.00	-21.39	QP

Note 1: All the channels and polarization had been tested, but only the worst data recorded in the report.

Note 2: EUT in each of three orthogonal axis emissions had been tested, but only the worst case (X axis) data recorded in the report.

8. AC POWER LINE CONDUCTED EMISSIONS

LIMITS

Please refer to FCC §15.207 (a) and RSS-Gen Clause 8.8

FREQUENCY (MHz)	Class A (dBuV)		Class B (dBuV)	
	Quasi-peak	Average	Quasi-peak	Average
0.15 -0.5	79.00	66.00	66 - 56 *	56 - 46 *
0.50 -5.0	73.00	60.00	56.00	46.00
5.0 -30.0	73.00	60.00	60.00	50.00

TEST SETUP AND PROCEDURE

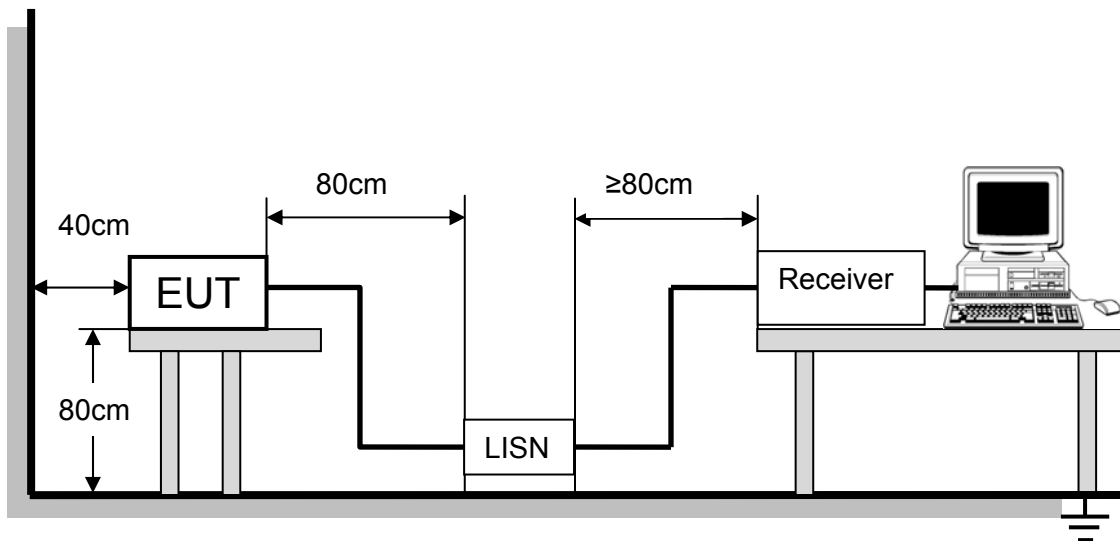

The EUT is put on a table of non-conducting material that is 80cm high. The vertical conducting wall of shielding is located 40cm to the rear of the EUT. The power line of the EUT is connected to the AC mains through a Artificial Mains Network (A.M.N.). A EMI Measurement Receiver (R&S Test Receiver ESR3) is used to test the emissions from both sides of AC line. According to the requirements in Section 7 and 13 of ANSI C63.4-2014. Conducted emissions from the EUT measured in the frequency range between 0.15 MHz and 30MHz using CISPR Quasi-Peak and average detector mode. The bandwidth of EMI test receiver is set at 9kHz.

The arrangement of the equipment is installed to meet the standards and operating in a manner, which tends to maximize its emission characteristics in a normal application.

TEST RESULTS (WORST-CASE CONFIGURATION)

EUT:	Bluetooth Headphone	Phase :	L
Test Mode:	Middle Channel		

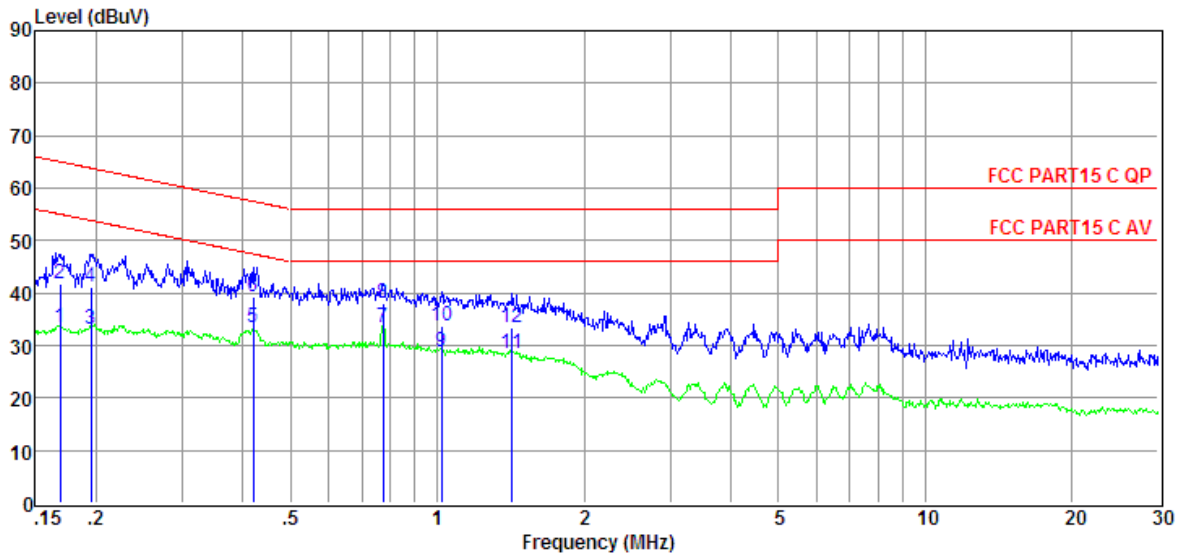

Item	Freq.	Read Level	LISN Factor	Cable Loss	Pulse Limiter Factor	Result Level	Limit Line	Over Limit	Detector
(Mark)	(MHz)	(dBμV)	(dB)	(dB)	(dB)	(dBμV)	(dBμV)	(dB)	
1	0.17	14.03	9.61	0.02	9.86	33.52	55.03	-21.51	Average
2	0.17	22.35	9.61	0.02	9.86	41.84	65.03	-23.19	QP
3	0.20	13.76	9.61	0.02	9.86	33.25	53.80	-20.55	Average
4	0.20	21.65	9.61	0.02	9.86	41.14	63.80	-22.66	QP
5	0.42	13.97	9.61	0.02	9.86	33.46	47.46	-14.00	Average
6	0.42	19.75	9.61	0.02	9.86	39.24	57.46	-18.22	QP
7	0.78	14.02	9.61	0.03	9.86	33.52	46.00	-12.48	Average
8	0.78	18.57	9.61	0.03	9.86	38.07	56.00	-17.93	QP
9	1.02	9.19	9.61	0.03	9.86	28.69	46.00	-17.31	Average
10	1.02	14.15	9.61	0.03	9.86	33.65	56.00	-22.35	QP
11	1.43	9.02	9.62	0.03	9.86	28.53	46.00	-17.47	Average
12	1.43	13.83	9.62	0.03	9.86	33.34	56.00	-22.66	QP

- Note: 1. Result Level = Read Level + LISN Factor + Pulse Limiter Factor + Cable loss.
 2. If QP Result complies with AV limit, AV Result is deemed to comply with AV limit.
 3. Test setup: RBW: 200 Hz (9 kHz—150 kHz), 9 kHz (150 kHz—30 MHz).
 4. Step size: 80Hz (0.009MHz-0.15MHz), 4 kHz (0.15MHz-30MHz), Scan time: auto.

EUT:	Bluetooth Headphone	Phase :	N
Test Mode:	Middle Channel		

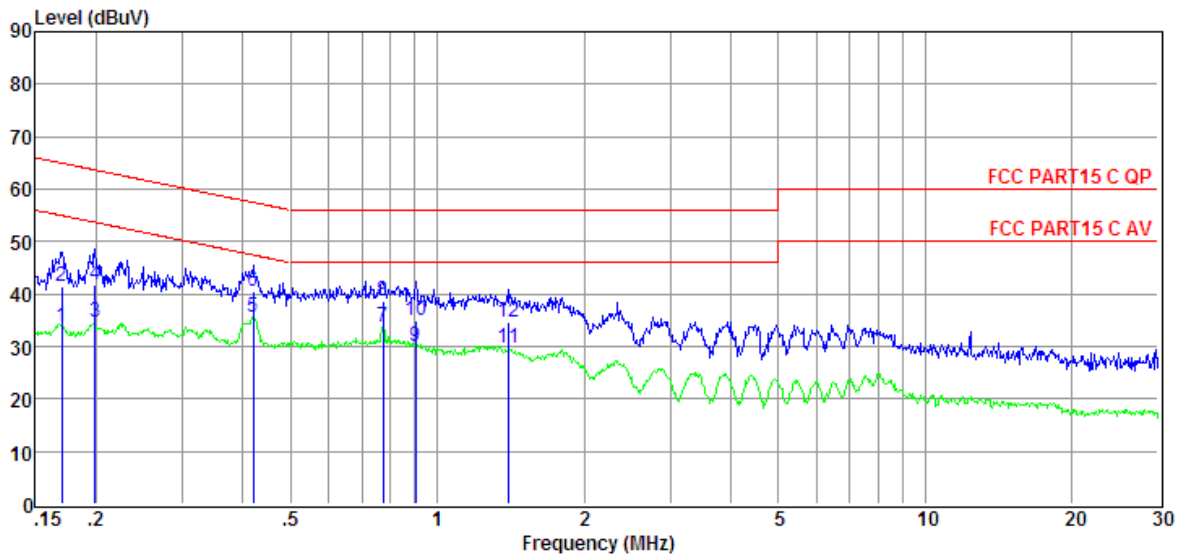

Item	Freq.	Read Level	LISN Factor	Cable Loss	Pulse Limiter Factor	Result Level	Limit Line	Over Limit	Detector
(Mark)	(MHz)	(dBμV)	(dB)	(dB)	(dB)	(dBμV)	(dBμV)	(dB)	
1	0.17	14.28	9.61	0.02	9.86	33.77	54.94	-21.17	Average
2	0.17	21.91	9.61	0.02	9.86	41.40	64.94	-23.54	QP
3	0.20	15.04	9.61	0.02	9.86	34.53	53.67	-19.14	Average
4	0.20	22.15	9.61	0.02	9.86	41.64	63.67	-22.03	QP
5	0.42	16.08	9.61	0.02	9.86	35.57	47.46	-11.89	Average
6	0.42	21.09	9.61	0.02	9.86	40.58	57.46	-16.88	QP
7	0.78	14.35	9.61	0.03	9.86	33.85	46.00	-12.15	Average
8	0.78	19.16	9.61	0.03	9.86	38.66	56.00	-17.34	QP
9	0.90	10.42	9.61	0.03	9.86	29.92	46.00	-16.08	Average
10	0.90	15.35	9.61	0.03	9.86	34.85	56.00	-21.15	QP
11	1.40	10.20	9.62	0.03	9.86	29.71	46.00	-16.29	Average
12	1.40	15.05	9.62	0.03	9.86	34.56	56.00	-21.44	QP

- Note: 1. Result Level = Read Level + LISN Factor + Pulse Limiter Factor + Cable loss.
 2. If QP Result complies with AV limit, AV Result is deemed to comply with AV limit.
 3. Test setup: RBW: 200 Hz (9 kHz—150 kHz), 9 kHz (150 kHz—30 MHz).
 4. Step size: 80Hz (0.009MHz-0.15MHz), 4 kHz (0.15MHz-30MHz), Scan time: auto.

Note: All the modulation and channels had been tested, but only the worst data recorded in the report.

9. ANTENNA REQUIREMENTS

APPLICABLE REQUIREMENTS

Please refer to FCC §15.203

If directional gain of transmitting antennas is greater than 6dBi, the power shall be reduced by the same level in dB comparing to gain minus 6dBi. For the fixed point-to-point operation, the power shall be reduced by one dB for every 3 dB that the directional gain of the antenna exceeds 6 dBi. The use of a permanently attached antenna or of an antenna that uses a unique coupling to the intentional radiator shall be considered sufficient to comply with the FCC rule.

ANTENNA CONNECTOR

EUT has a PCB antenna without antenna connector.

ANTENNA GAIN

The antenna gain of EUT is less than 6 dBi.

END OF REPORT

Page 58 of 58