

Muon

A528B

Compact Embedded UHF RFID Reader

A528ADAT

USB RS232 Adapter Board



easy2read®



Technical Information Manual

Revision n. 05

16/07/2013

Scope of Manual

The goal of this manual is to provide the basic information to work with the A528B Muon Compact Embedded UHF RFID Reader.

Change Document Record

Date	Revision	Changes	Pages
20 Feb 2013	00	Preliminary release	-
19 Mar 2013	01	Added § <i>EC Declaration of Conformity</i>	27, 29
21 Mar 2013	02	Modified <i>Return link characteristics</i> in the <i>Tab. 2.1: Muon A528B Technical Specifications</i>	10
30 Apr 2013	03	Added <i>Federal Communications Commission (FCC) Notice (Preliminary)</i>	3
		Added <i>FCC Compliance</i> paragraph	27
		Changed <i>Tab. 2.1: Muon A528B Technical Specifications Table</i>	10
27 May 2013	04	Modified <i>FCC Compliance</i> paragraph	27
16 Jul 2013	05	Modified <i>FCC Compliance</i> paragraph	27

Reference Document

- [RD1] EPCglobal: EPC Radio-Frequency Identity Protocols Class-1 Generation-2 UHF RFID Protocol for Communications at 860 MHz – 960 MHz, Version 1.1.0 (December 17, 2005).
- [RD2] G.S.D. s.r.l. - Report CE mark – A528B Muon Compact Embedded UHF RFID Reader. Test report n. 13122 Rev.00 - 12 March 2013.

CAEN RFID srl

Via Vetraia, 11 55049 Viareggio (LU) - ITALY
Tel. +39.0584.388.398 Fax +39.0584.388.959
info@caenrfid.com
www.caenrfid.com

© CAEN RFID srl – 2010

Disclaimer

No part of this manual may be reproduced in any form or by any means, electronic, mechanical, recording, or otherwise, without the prior written permission of CAEN RFID.

The information contained herein has been carefully checked and is believed to be accurate; however, no responsibility is assumed for inaccuracies. CAEN RFID reserves the right to modify its products specifications without giving any notice; for up to date information please visit www.caenrfid.com.

Federal Communications Commission (FCC) Notice (Preliminary)

This device was tested and found to comply with the limits set forth in Part 15 of the FCC Rules. Operation is subject to the following conditions: (1) this device may not cause harmful interference, and (2) this device must accept any interference received including interference that may cause undesired operation. These limits are designed to provide reasonable protection against harmful interference when the equipment is operated in a commercial environment.

This device generates, uses, and can radiate radio frequency energy. If not installed and used in accordance with the instruction manual, the product may cause harmful interference to radio communications. Operation of this product in a residential area is likely to cause harmful interference, in which case, the user is required to correct the interference at their own expense. The authority to operate this product is conditioned by the requirements that no modifications be made to the equipment unless the changes or modifications are expressly approved by CAEN RFID.

Disposal of the product

Do not dispose the product in municipal or household waste. Please check your local regulations for disposal/recycle of electronic products.



Index

Scope of Manual	2
Change Document Record	2
Reference Document	2
Index	4
List of Figures.....	5
List of Tables.....	5
1 Introduction	6
General Information	7
Ordering Options	8
2 Muon A528B	9
Technical Specifications Table	10
External Connections	11
A528B Main connector pinout.....	11
A528B Main connector electrical characteristics	12
Power supply connection	13
General purpose I/O connections	13
External reset	14
UART connection	14
A528B recovery	15
A528B USB connector pinout	15
A528B USB connector electrical characteristics.....	16
Antenna port specifications.....	16
Reader - Tag Link Profiles	17
Host communication interfaces	17
Firmware Upgrade	18
A528B USB Recovery/FW upgrade.....	18
A528B RS232 Firmware upgrade	19
3 Muon A528ADAT.....	20
Technical Specifications Table	21
Connection Diagram	21
Installation Notice.....	22
Technical drawings	23
Electrical scheme	24
External Connections	25
LEDs	25
Switches	25
Firmware Upgrade	25
4 Muon Regulatory Compliance	26
FCC Compliance	27
CE Compliance	27
RoHS EU Directive	28
EC Declaration of Conformity	29

List of Figures

Fig. 1.1: Muon A528B OEM UHF Compact Reader.....	7
Fig. 1.2: Muon A528ADAT USB RS232 Adapter	7
Fig. 2.1: Muon A528B Technical Drawings	11
Fig. 2.2: Muon A528B Power Supply Connection	13
Fig. 2.3: Muon A528B GPIO Connection Example.....	13
Fig. 2.4: Muon A528B External Reset.....	14
Fig. 2.5: Muon A528B RS232 Connection.....	14
Fig. 2.6: Muon A528B TST-Recovery Connection.....	15
Fig. 2.7: Muon A528B USB Interface Connection	15
Fig. 3.1: Muon A528ADAT Connection Diagram	21
Fig. 3.2: Connection of the Muon A528B module to the A528ADAT adapter board.....	22
Fig. 3.3: Muon A528ADAT Technical Drawing	23
Fig. 3.4: Muon A528ADAT Electrical Scheme	24

List of Tables

Tab. 2.1: Muon A528B Technical Specifications	10
Tab. 2.2: Muon A528B Main Connector Pinout.....	11
Tab. 2.3: Muon A528B Main Connector electrical characteristics	12
Tab. 2.4: Muon A528B USB Connector Electrical Specifications.....	15
Tab. 2.5: Muon A528B USB Connector Electrical Characteristics	16
Tab. 2.6: RF Port Pinout	16
Tab. 2.7: RF Port Electrical Characteristics	16
Tab. 2.8: Muon A528B Reader to Tag Link Profiles.....	17
Tab. 3.1: Muon A528ADAT Technical Specifications.....	21

1 Introduction

This Chapter gives general information about the **A528B Muon** Compact Embedded UHF RFID Reader. It contains these topics:

- [General Information](#)
- [Ordering Options](#)



General Information

The Muon (Model A528B) is an OEM UHF multiregional compact reader of the easy2read® Family for high performances UHF RFID applications.

With programmable output power in 8 steps from 10dBm to 27dBm, the reader can detect tags up to 3m of distance¹.

Due to its form factor, the module is specifically designed to be easily embedded either in battery powered devices, such as industrial handhelds, or fixed reading point devices, such as printers, point of sales, self-service kiosks or industrial automation readers.

The radio frequency core of the module allows achieving fast reading/writing and operation in dense reader and dense tag environments for top-class rated performances.

The A528B complies with and can operate in both European and US regulatory environments and, due to its multiregional capabilities, it's ideal for integration in devices requiring compliance to different geographical regions.



Fig. 1.1: Muon A528B OEM UHF Compact Reader

The Mod. A528ADAT USB / RS232 service board allows managing the Mod. A528B OEM UHF multiregional Compact Reader directly via USB and RS232 interfaces. This board is particularly suited for A528B reader evaluation and SW development purpose.

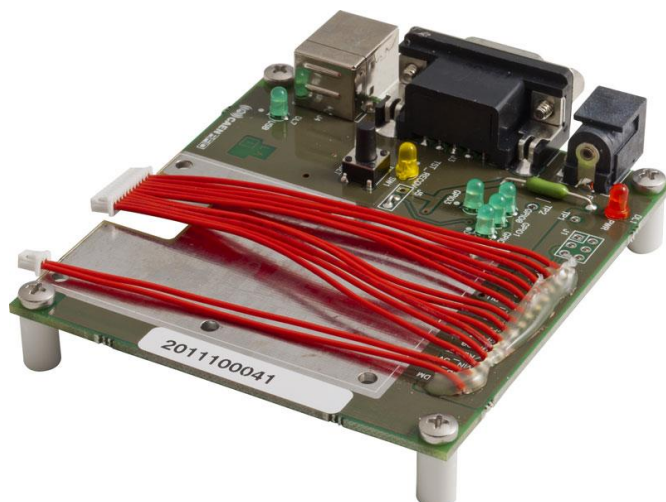

Fig. 1.2: Muon A528ADAT USB RS232 Adapter

¹ depending on antenna and tag dimensions.

Ordering Options

	Code	Description
Reader	WA528BXAAAAA	A528B Muon Compact Embedded UHF RFID Reader.
Accessories	WANTENNAX004	Linear polarized 3db gain 870 MHz PIFA antenna
	WANTENNAX008	Linear polarized antenna for handheld units 865 - 870 MHz
	WANTENNAX009	Linear polarized antenna for printers 865 - 870 MHz
	WANTENNAX010	Linear polarized 3db gain 915 MHz PIFA antenna
	WANTENNAX011	Linear polarized antenna for handheld units 915 MHz
	WANTENNAX012	Linear polarized antenna for printers 902 - 928 MHz
	A528ADAT	A528 (MUON) USB/RS232 Adapter Board
	WALIM0000002	Power Supply for A528 Adapter Board

2 Muon A528B

This Chapter provides the basic information to work with the **A528B Muon** Compact Embedded UHF RFID Reader. It contains these topics:

- [Technical Specifications Table](#)
- [External Connections](#)
- [Reader - Tag Link Profiles](#)
- [Host communication interfaces](#)
- [Firmware Upgrade](#)



Technical Specifications Table

Frequency Range	902÷928 MHz (FCC part 15.247) 865.600÷867.600 MHz (ETSI EN 302 208 v1.4.1)
RF Power	Programmable in 8 levels from 10dBm to 27dBm
Output Power Accuracy	+/- 1dB
Antenna VSWR Requirement	<2:1 or better for optimum performances
Antenna Connector	Nr. 1 MMCX jack
Frequency Tolerance	±10 ppm over the entire temperature range
Number of Channels	4 channels (compliant to ETSI EN 302 208 v1.4.1) 50 hopping channels (compliant to FCC part 15.247)
Standard Compliance	EPC C1G2 [RD1]
Forward link characteristics	DSB-ASK 40kBit/s; PR-ASK 40kBit/s; DSB-ASK 160kBit/s (FCC only)
Return link characteristics	FM0 40kbit/s Miller encoding (M=4;LF=250kHz) Miller encoding (M=4;LF=300kHz) FM0 400kbit/s (FCC only)
Digital I/O	Four I/O lines 3.3V out @ 3mA; 5V tolerant
Connectivity	UART Serial Port: Baudrate: up to 115200 Databits: 8 Stopbits: 1 Parity: none Flow control: none 3.3V level USB Device Port: One USB 2.0 Full Speed (12 Mbits per second) device port.
Dimensions	(W)42 x (L)60 x (H)6.3 mm ³ (1.65 x 2.36 x 0.25 inch ³)
DC Power	4.75V ÷ 5.25V ripple and noise < 100mVpp ripple frequency > 100kHz
Power Consumption	1A peak @ 5 V (TX/RX mode) 230 mA @ 5 V (idle mode)
Operating Temperature	-20 °C to 60 °C
Weight	18 g

Tab. 2.1: Muon A528B Technical Specifications



Warning: please set up the correct RF regulation of your country following the CAEN RFID instructions.

External Connections

The location of the connectors is shown in Fig. 2.1: Muon A528B Technical Drawings pag. 11. Their mechanical specifications are listed here below:

Antenna Port: RF Coax Connector Huber+Suhner type 82MMCX-S50-0-2/111_K (to be used with Huber+Suhner type 11MMCX-50-1-1/111_O)

MOLEX Connector: PCB Headers Molex type 53261-1271
(to be used with Molex Type 51021-1200 + 12pcs crimp terminal type 50058-8100)

MOLEX Connector: PCB Headers Molex type 53261-0271
(to be used with Molex Type 51021-0200 + 2pcs crimp terminal type 50058-8100)

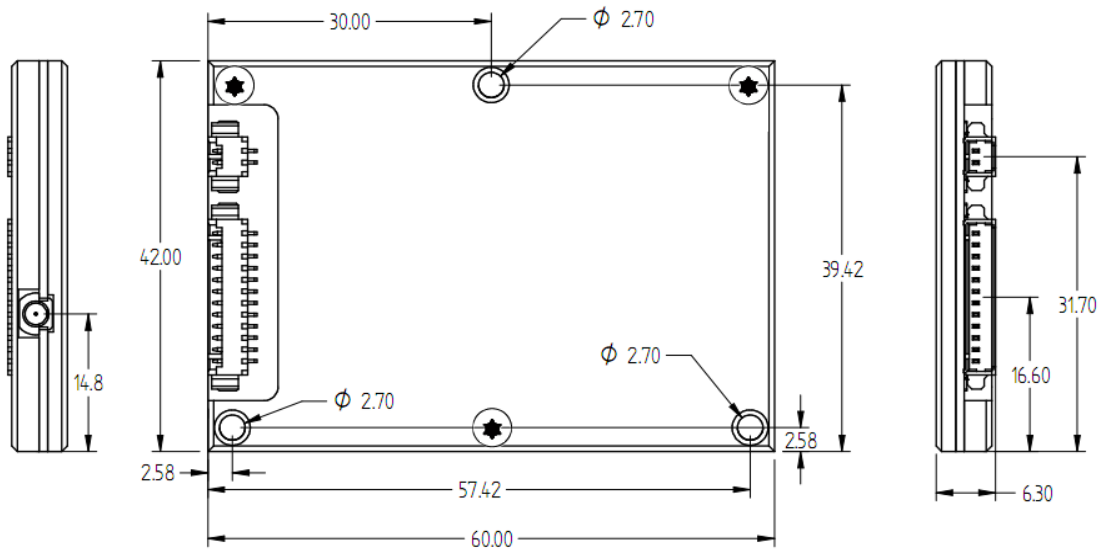

Physical dimension: millimeters

Fig. 2.1: Muon A528B Technical Drawings

A528B Main connector pinout

Compact reader A528B MAIN external connector is a Molex SMD, 12 poles, 1.27 pitch connector whose pinout is shown in table below.

Pin #	Function	Direction
1	Power Line (+5V)	-
2	/RESET	IN
3	GPIO0	IN/OUT
4	GPIO1	IN/OUT
5	GPIO2	IN/OUT
6	GPIO3	IN/OUT
7	TST_RECOVERY	IN
8	USB PUP	IN
9	RXD	IN
10	TXD	OUT
11	GND	-
12	GND	-

Tab. 2.2: Muon A528B Main Connector Pinout

The GPIO0-GPIO3 pin are 4 general purpose bidirectional pins, their default direction (or after a Reset) is OUT.

TST_RECOVERY pin is reserved and shall be used only to perform the microcontroller recovery procedure during which it must be forced at high level (3.3V or 5V).

The RXD/TXD pins are used to communicate with the A528 board via UART port; to establish a link with the device you must configure your COM port as follows²:

Baud rate: 115200
 Parity: None
 Data bits: 8
 Stop bits: 1
 Flow Control: none

A528B Main connector electrical characteristics³

Pin name	Pin No.	Parameter	Min	Typ	Max	Unit
+5V	1	Supply DC voltage	4.75	5.00	5.25	V
		Power supply requirements – Ripple Voltage			100	mVpp
		Power supply requirements - Ripple Frequency	100			kHz
		Supply DC current	0.23		1.0	A
/RESET	2	VIL	-0.3		1.0	V
		VIH	2.4		3.6	V
		Internal pull-up resistance	10	20		kΩ
		Pulse width	1			μs
GPIO[0:3]	3, 4, 5, 6	VOL	0		0.4	V
		VOH	2.0		3.3	V
		Output current			3.0	mA
		VIL	-0.3		0.8	V
		VIH	2.0		5.5	V
		Input current			1	μA
TST-Recovery	7	VIH	2.0		5.5	V
USB PUP	8	VIH	2.0		5.5	V
RXD	9	VIL	-0.3		0.8	V
		VIH	2.0		5.5	V
		Input current			1	μA
TXD	10	VOL	0		0.4	V
		VOH	2.4		3.3	V
		Output current			1.5	mA
GND	11,12					

Tab. 2.3: Muon A528B Main Connector electrical characteristics

² Since A528B RX/TX are TTL level signals, in order to connect it with a PC, a TTL/RS232 translator shall be used.

³ Exceeding maximum values reported in the table may cause permanent damage to the model.

Power supply connection

In the following schematic suggested A528B power supply connection is shown.

The use of fuse F1 is recommended since A528B does not provide internal current limitation protection. Diode D1 avoid damage to the reader in case of reverse polarity connection. The use of optional LC filter improves reader immunity in presence of noisy power supply.

In order to ensure the correct operation of the reader the power supply shall not enter in burst mode (switching frequency less than 100 kHz) when A528B reader is in idle mode (supply current less than 0.2A). As a rule of thumb the power adapter shall have a maximum current rating from 1A to 1.5A.

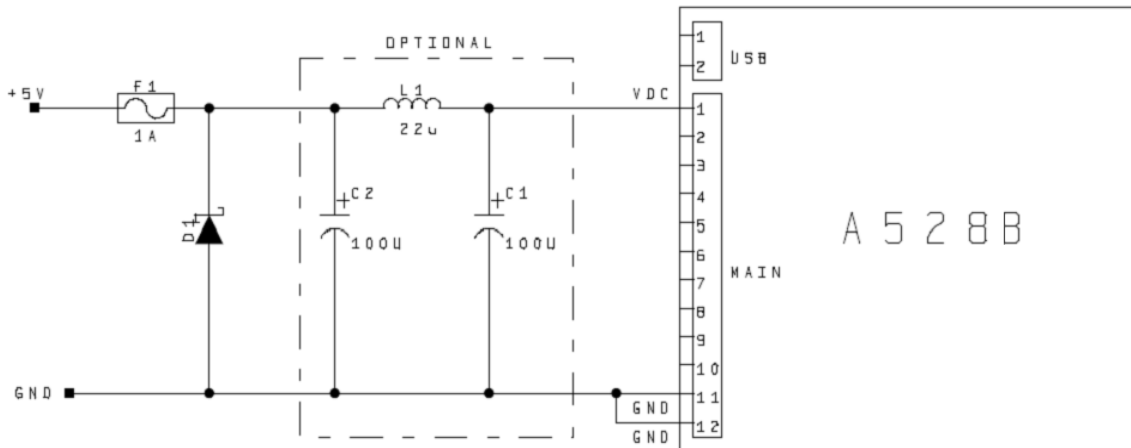

Fig. 2.2: Muon A528B Power Supply Connection

General purpose I/O connections

The GPIO0-GPIO3 pins are 4 general-purpose bidirectional pins. Their default direction after a power on reset or a general reset is set to Output.

GPIO, when configured as Outputs, can be used to drive indicators as leds or buzzers or to send trigger signal to others equipments.

GPIO, when configured as Inputs, can accept control signals from other equipments or trigger signals from sensors (i.e. photocells).

In the following schematic an example of application of GPIO is shown.

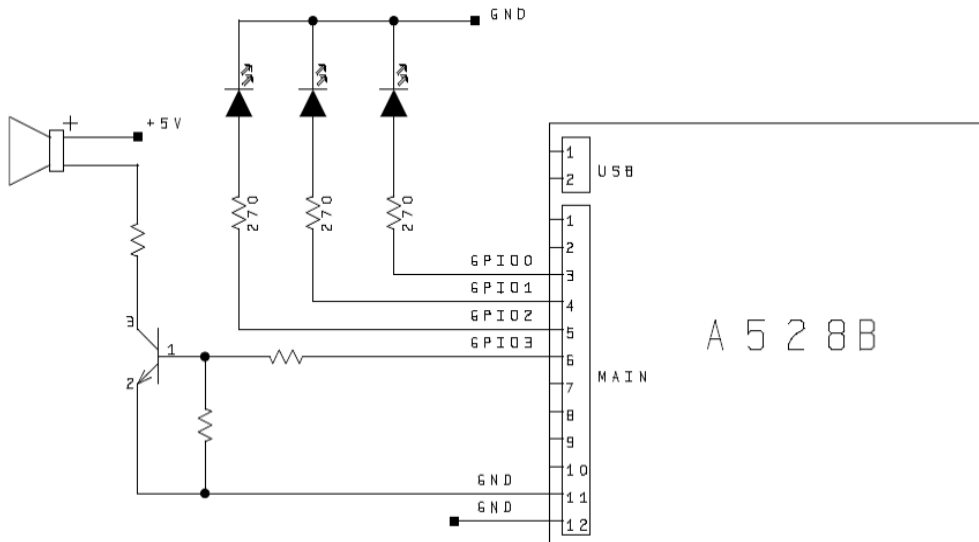

Fig. 2.3: Muon A528B GPIO Connection Example

External reset

A528B manual reset can be performed by forcing at low level /RESET pin for 1 μ S at least. /RESET pin is pulled-up by an internal resistor.

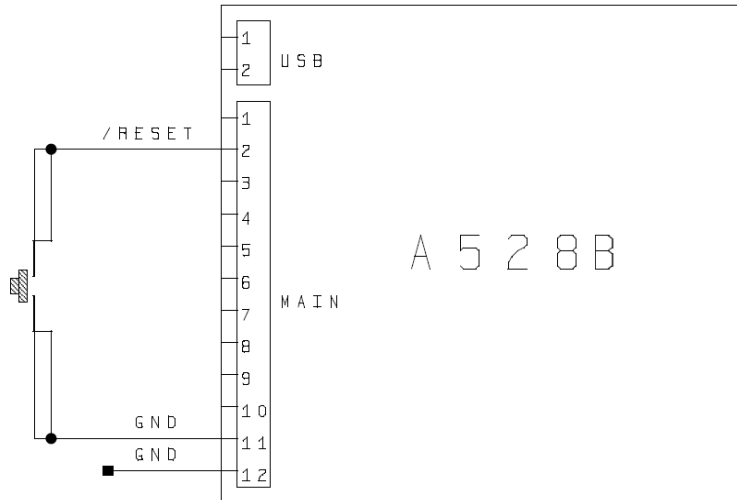

Fig. 2.4: Muon A528B External Reset

UART connection

The RXD/TXD pins are used to communicate with the A528 board via UART port. Since A528B RX/TX are TTL level signals, in order to connect it with a PC, a TTL/RS232 translator shall be used (please refer to the diagram below)⁴.

To establish a link with the device host COM port shall be configured as follows:

- Baud rate: 115200
- Parity: None
- Data bits: 8
- Stop bits: 1
- Flow Control: none

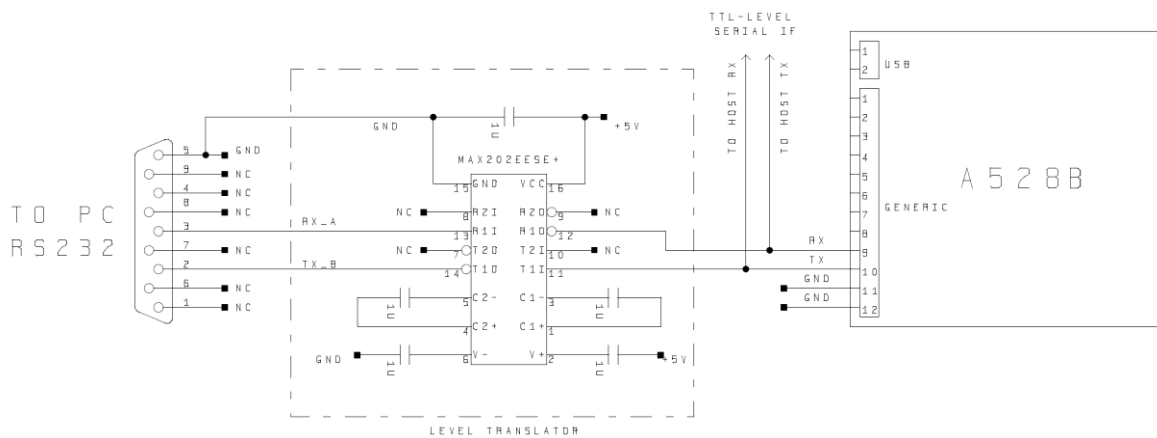

Fig. 2.5: Muon A528B RS232 Connection

⁴ A528 service board (A528ADAT) hosts both RS232 and USB full interfaces.

A528B recovery

TST_RECOVERY pin is reserved and shall be used only to perform the microcontroller recovery procedure during which it must be forced at high level (3.3V or 5V).

In the following diagram a manual recovery mechanism is shown: in order to perform the A528B boot recovery the jumper JP1 shall be inserted, than A528B shall be switched on by applying 5V supply voltage for 5s at least. After that the reader shall be switched off and the jumper removed: at the next switch on the reader will execute the boot recovery program.

For further details please see § *Firmware Upgrade* pag.18.

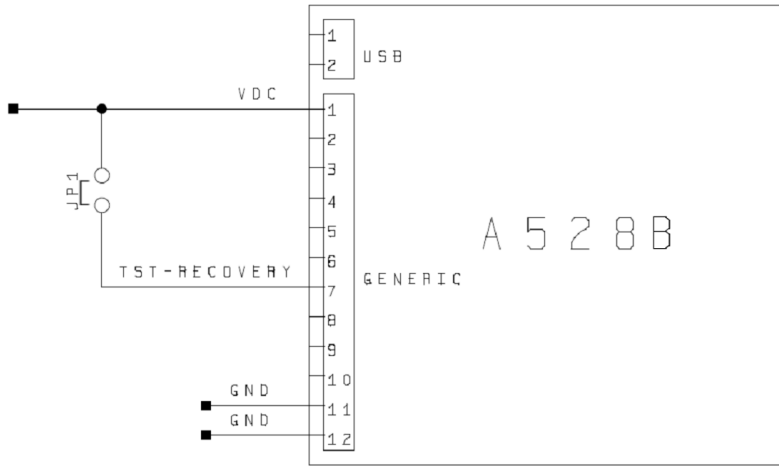

Fig. 2.6: Muon A528B TST-Recovery Connection

A528B USB connector pinout

A528B USB interface connector is a Molex SMD, 2 poles, 1.27 pitch connector whose pinout is shown in table below.

Pin #	Function	Direction	Description
1	DDM	IN/OUT	USB data -
2	DDP	IN/OUT	USB data +

Tab. 2.4: Muon A528B USB Connector Electrical Specifications

A528 board provides only the USB data signals; in order to implement a full USB interface some external components shall be used. The external circuit necessary for A528B USB operation is shown in the schematic below.

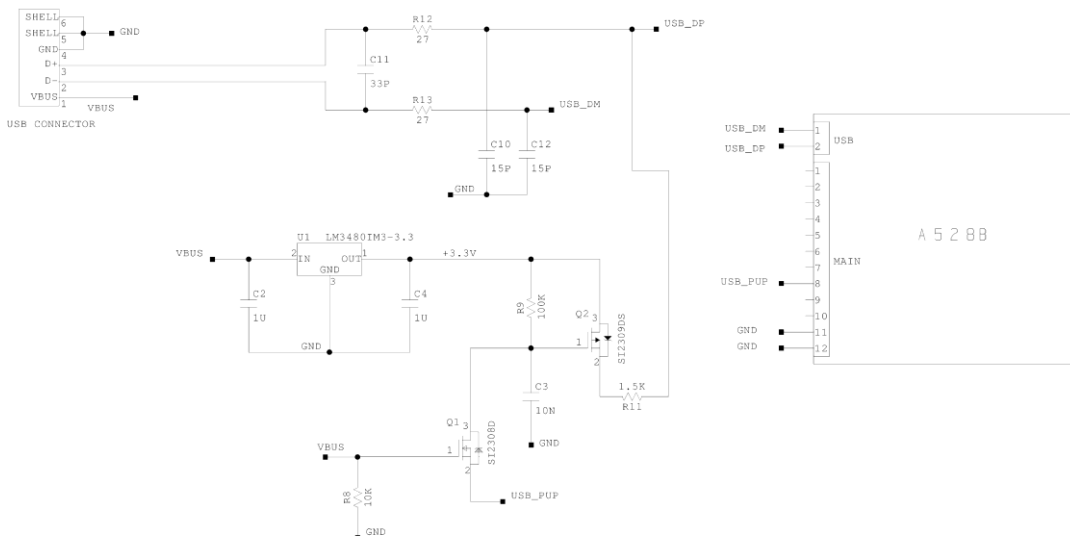

Fig. 2.7: Muon A528B USB Interface Connection

A528B USB connector electrical characteristics⁵

Pin name	Pin No.	Parameter	Min	Type	Max	Unit
DDM	1	V_{IL}			0.8	V
		V_{IH}	2			V
		V_{OL}	0		0.3	V
		V_{OH}	2.8		3.3	V
		Recommended external series resistor		27		Ω
DDP	2	V_{IL}			0.8	V
		V_{IH}	2			V
		V_{OL}	0		0.3	V
		V_{OH}	2.8		3.3	V
		Recommended external series resistor		27		Ω

Tab. 2.5: Muon A528B USB Connector Electrical Characteristics

Antenna port specifications

In the following table the pinout of A528B antenna is shown.

Pin #	Function	Direction	Description
INNER	RF OUT	OUT	RF output
OUTER	GND	-	Ground

Tab. 2.6: RF Port Pinout

Parameter	Min	Typ.	Max	Unit
RF output power (nominal)	10		500	mW
	10		27	dBm
Output power vs. power setting accuracy			± 1	dB
RF port impedance		50		Ω
Recommended antenna VSWR			2:1	-

Tab. 2.7: RF Port Electrical Characteristics

⁵ Exceeding maximum values reported in the table may cause permanent damage to the model.

Reader - Tag Link Profiles

A528B reader supports different modulation and return link profiles according to EPC Class1 Gen2 protocol [RD1].

In the following table are reported all profiles that have been tested for the compliance with ETSI and FCC regulations.

Link profile #	Regulation	Modulation	Return Link
0	ETSI - FCC	DSB-ASK; f=40kHz	FMO; f = 40kHz
1	ETSI - FCC	PR-ASK; f=40kHz	Miller (M=4); f = 250kHz
2	ETSI	PR-ASK; f=40kHz	Miller (M=4); f = 300kHz
3	FCC	DSB-ASK; f=160kHz	FMO; f = 400kHz
4	FCC	PR-ASK; f=40kHz	Miller (M=2); f = 250kHz

Tab. 2.8: Muon A528B Reader to Tag Link Profiles

Host communication interfaces

A528B reader allows the user to manage host communication through the CAEN communication protocol⁶: the host-reader interface is serial and A528B is fully compatible with all the CAEN Demos and libraries included in the [Easy2Read SDK](#).

Only if the use of USB interface is necessary, it is available the Intel communication protocol: the host-reader interface is USB. Using the Intel protocol, serial interface has debug purpose only. Intel communication protocol is not supported by CAEN RFID.

The default setting of the A528B reader is the Serial/CAEN choice, in order to switch to the INTEL protocol on USB interface you shall follow the steps described below:

1. Connect to the reader, using a RS232 cable⁷, with the Hyperterminal (or with any other terminal emulation application) with the following settings:
 baud rate: 115200
 data bits: 8
 parity: none
 stop bits: 1
 Flow control: None
2. Type quickly the word *CAEN* (in capital letters) in the hyperterminal window.
3. Type *chgprot* in the hyperterminal window.
4. Select the *USB interface* and *INTEL protocol* options when prompted.

After a reset the reader will reply to the INTEL commands.

In order to switch from the INTEL protocol on USB interface to the Serial/CAEN protocol you shall follow the steps described below:

1. Connect to the reader, using a RS232 cable⁸, with the hyperterminal (or with any other terminal emulation application) with the following settings:
 baud rate: 115200
 data bits: 8
 parity: none
 stop bits: 1
 Flow control: None
2. Stop the boot process pressing the spacebar within 6 seconds from the power on.
3. Type *chgprot* in the hyperterminal window.
4. Select the *Serial interface* and *CAEN protocol* options when prompted.

After a reset the reader will reply to the CAEN commands.

⁶ Serial / CAEN protocol is implemented starting from FW release 1.1.5.

⁷ Assuming to use A528 adapter board and a PC as host.

⁸ Assuming to use A528 adapter board and a PC as host.

Firmware Upgrade

The A528B reader firmware upgrade can be performed via USB or RS232 interface.

In the use of RS232 interface, it is assumed to use the A528 adapter board and a PC as host.

A528B USB Recovery/FW upgrade

USB upgrade is based on Atmel Smart Arm Microcontroller Boot Assistant (hence forth referred to as "SAM-BA"). The SAM-BA tool is distributed by Atmel and it is available for free at Muon A528B web page or in the Software and Firmware Area of the CAEN RFID Web Site (download the SAM-BA tool and install the AT91-ISP.exe file).

USB upgrade requires the following steps:

- With power supply disconnected, connect with a jumper J5 pin 1 and pin 2.
- With short circuit inserted connect the power supply to the board and wait for 5 seconds at least.
- Disconnect the power supply.
- Remove the jumper.
- Connect the power supply and the USB cable to A528ADAT.
- At this point, Windows XP will detect the platform (in SAM-BA mode) and display the *Found New Hardware Wizard*.
- The first screen asks if Windows can connect to Windows Update to search for the software, select: *No, not this time* and then click the *NEXT* button.
- On the next wizard screen, select: *Install the software automatically* then click the *NEXT* button.
- A dialog will popup indicating that the driver has not passed *Windows Logo Testing*, click the *CONTINUE ANYWAY* button.
- When the last screen appears, click the *Finish* button to dismiss the New Hardware Wizard.
- Reboot PC when prompted.
- Run the SAM-BA v2.6 application on the WinXP host machine.
- When a dialog box appears, ensure AT91SAM7S256-EK is selected in the drop down list then click on the *USB connection* button. Note that a number of the names in the dropdown list are similar so ensure you select the correct one.
- Ensure the *FLASH* tab is selected.
- Enter the path in the *Send File Name* or use the corresponding *Browse* button to find and select the file containing the new firmware. Latest release can be downloaded from [CAEN RFID website](#).
- Click the *Send File* button.
- Click *Yes* in response to *Do you want to unlock involved lock region(s)*. Click *No* in response to *Do you want to lock involved lock region(s)*. Finally - confirm the programming by clicking the *Compare sent file with memory* button. When SAM-BA reports that the files are identical click the *OK* button.
- Exit the SAM-BA application via the File -> Quit option.
- To ensure correct behaviour of Windows XP, click the *Safely Remove Hardware* icon in the Windows system tray, and Stop the Atmel Test Board entry and power DOWN your A528ADAT (disconnect power supply).

A528B RS232 Firmware upgrade

The Muon A528B Upgrade Tool is available for free at Muon A528B web page or in the Software and Firmware Area of the CAEN RFID Web Site.

To perform the FW upgrade via RS232 interface these steps shall be followed:

- Turn off the reader.
- Connect the reader with the RS232 serial cable to your PC using the adapter board A528ADAT.
- Setup a serial terminal (such hyperterminal available on all windows OS) with the following settings:

baud rate:	115200
data bits:	8
parity:	none
stop bits:	1
Flow control:	None
- Turn on the reader.
Type quickly and in capital letters the word *CAEN*.
In case the A528B is configured to use INTEL protocol a boot message will appear, press the space bar within 8 seconds from boot.
- After that in both cases a prompt ">" should be displayed. The reader is waiting for commands to be sent over the serial port.
- Type *upgrade*, press return and disconnect the serial port.
- Launch the downloaded upgrade tool (AT91SAM7SERIALBOOT.exe).
- Select the COM port you are using (typically is COM1) with the radio button on the left of the main window and press the connect button.
- Click the *Open* button and Browse until you find the .bin firmware upgrade image.
- Press the Download button. If, for any reason, the upgrade procedure fails, do not power off the reader but press the download button again.
- At the end power off the reader and power it on again.

Firmware upgrade has been completed.

If some problems occur in this procedure, the recovery of module operation can be obtained by performing the procedure described in § *A528B USB Recovery/FW upgrade* pag. 18.

3 Muon A528ADAT

This Chapter provides the basic information to work with the **Muon A528ADAT USB RS232 Adapter Board**. It contains these topics:

- [Technical Specifications Table](#)
- [Connection Diagram](#)
- [Technical drawings](#)
- [Electrical scheme](#)
- [External Connections](#)
- [LEDs](#)
- [Switches](#)



Technical Specifications Table

Digital I/O	Four I/O lines 3.3 V out @ 3mA, 5 V tolerant
USB Port	USB B female connector USB 2.0 device It appears as USB A528B device; drivers for Windows XP, Windows CE 5.0, Linux 4 and greater
RS232 Port	Baudrate: 115200 Databits: 8 Stopbits: 1 Parity: none Flow control: none 9.6÷115 kbit/s data rate (settable)
LED display	RED: Power GREEN: GPIO[0..3], USB connection YELLOW: RECOVERY procedure
Dimensions	(W)81 x (L)76 x (H)28 mm ³ (3.2 x 3.0 x 1.1 inch ³)
Electrical Power	DC Voltage 5V +/-5% Current consumption: 1A max.
Operating Temperature	-20 °C to +60 °C

Tab. 3.1: Muon A528ADAT Technical Specifications

Connection Diagram

The following block diagram shows how to connect the Muon A528B with the PC host via the Muon A528ADAT service board.

The board equipped with A528B reader shall be powered by external 5V 1A DC adapter. In order to ensure the correct operation of the reader the power supply shall not enter in burst mode (switching frequency less then 100kHz) when A528B reader is in idle mode (supply current about 0.2A). As a rule of thumb the power adapter shall have a maximum current rating from 1A to 1.5A.

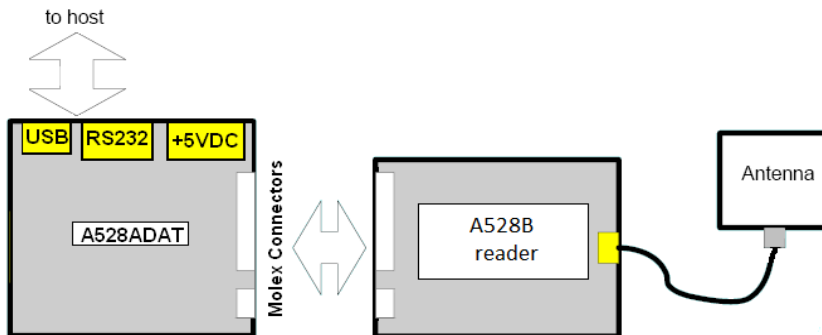

Fig. 3.1: Muon A528ADAT Connection Diagram

Installation Notice

Fix the Muon A528B reader to the A528ADAT using 3 screws M2,5x12 and 3 screws nuts M2,5 and connect the respective connectors.

The correct way to connect the Muon A528B module to the A528ADAT adapter board is shown in the following picture:

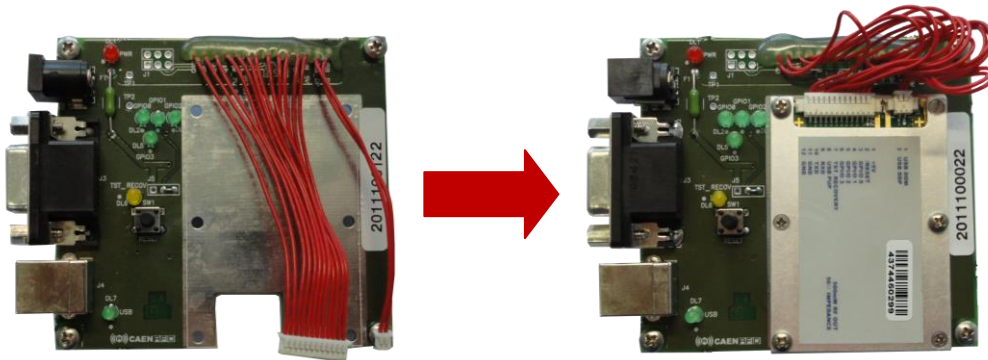

Fig. 3.2: Connection of the Muon A528B module to the A528ADAT adapter board

Technical drawings

The following drawing shows the Muon A528ADAT components position.

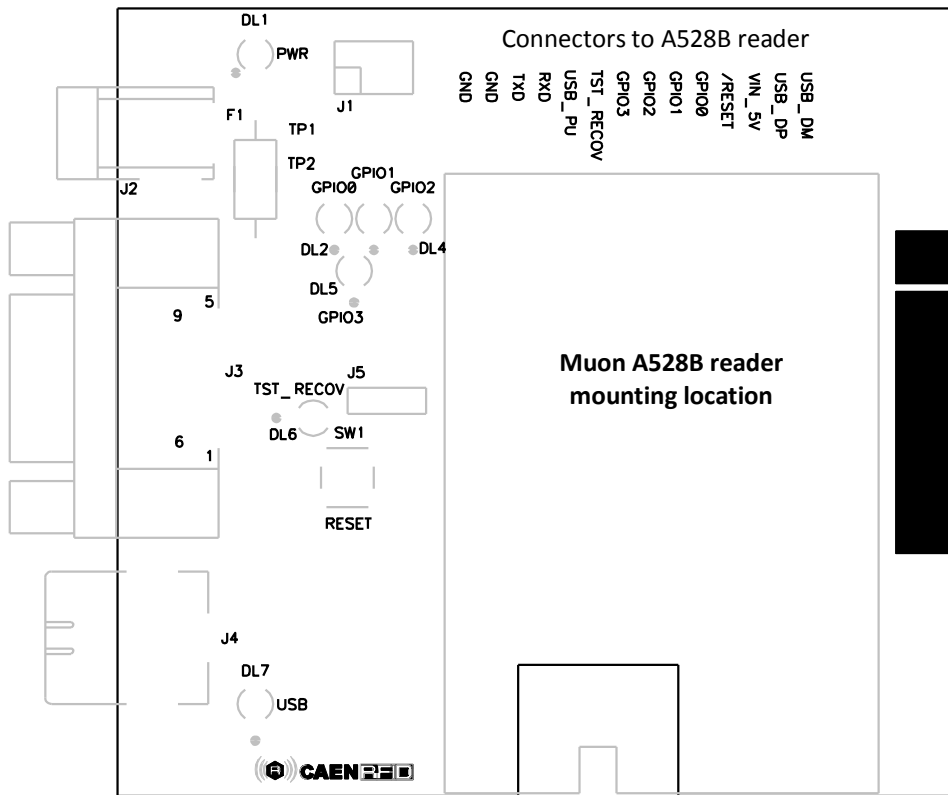

Fig. 3.3: Muon A528ADAT Technical Drawing

Electrical scheme

The electrical scheme of the Muon A528ADAT is shown in Fig. 3.4: Muon A528ADAT Electrical Scheme.

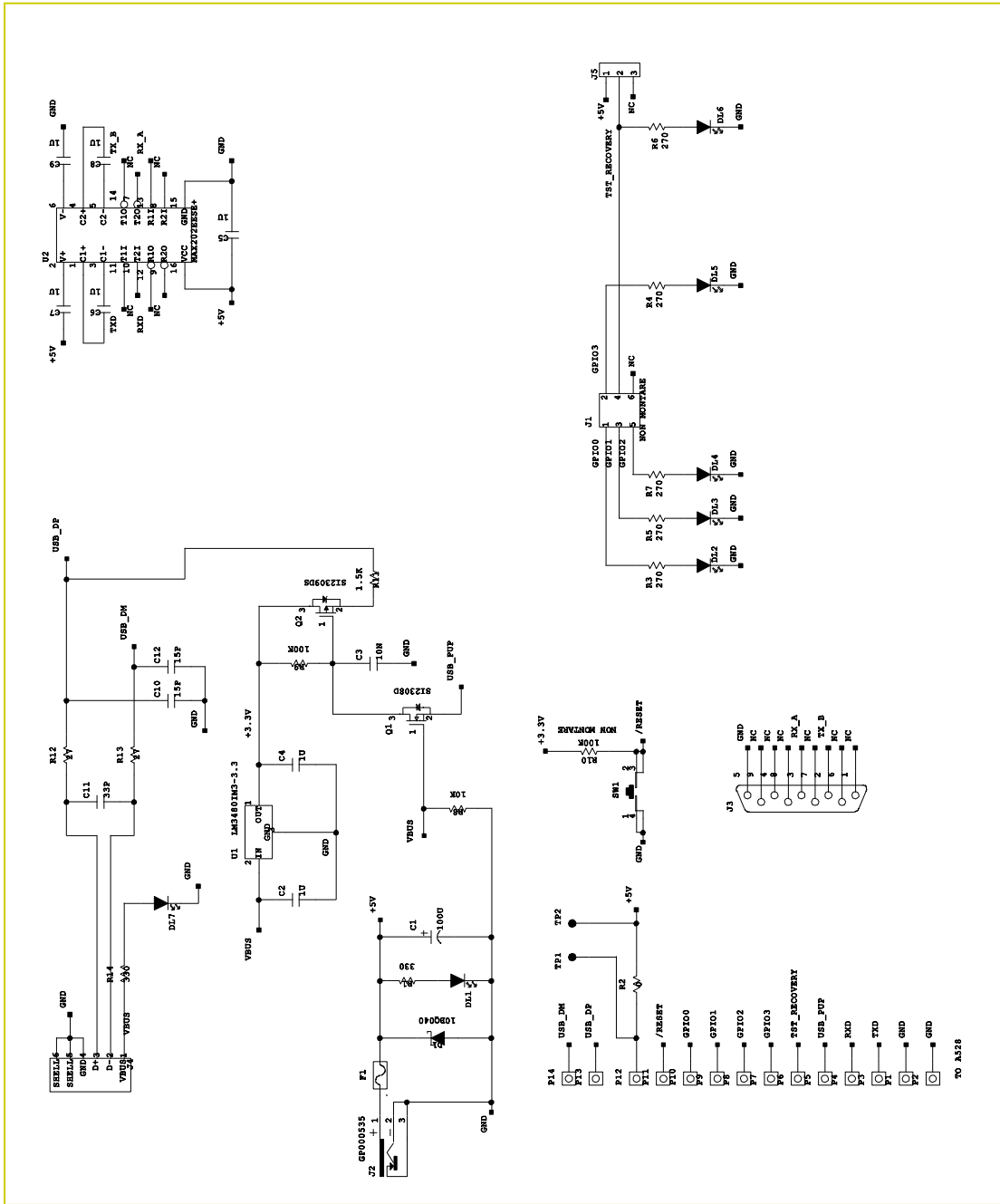

Fig. 3.4: Muon A528ADAT Electrical Scheme

External Connections

Please refer to § Fig. 3.3: *Muon A528ADAT Technical Drawing* pag.23.

J1: free PTH pads for GPIO external connection

- J1-1 = GPIO0 (in/out)
- J1-2 = GPIO3 (in/out)
- J1-3 = GPIO1 (in/out)
- J1-4 = TST_RECOVERY
- J1-5 = GPIO2 (in/out)
- J1-6 = Not Connected

J2: Power Supply connector: central pin (2.54mm diam.) is the positive terminal.

J3: RS232 DB9 female connector

J4: USB Type B port

J5: Connector for Boot Recovery Procedure

LEDs

Please refer to § Fig. 3.3: *Muon A528ADAT Technical Drawing* pag.23.

DL1 (red) = Power Supply

DL2 (green) = GPIO0

DL3 (green) = GPIO1

DL4 (green) = GPIO2

DL5 (green) = GPIO3

DL6 (yellow) = TST_RECOVERY

DL7 (green) = USB connection

Switches

Please refer to § Fig. 3.3: *Muon A528ADAT Technical Drawing* pag.23.

SW1 = RESET

Firmware Upgrade

Please refer to § *Firmware Upgrade* pag. 18.

4 Muon Regulatory Compliance

This Chapter gives information on the **Muon A528B Reader** Regulatory Compliance. It contains these topics:

- [FCC Compliance](#)
- [CE Compliance](#)
- [RoHS EU Directive](#)
- [EC Declaration of Conformity](#)



FCC Compliance

This equipment has been tested and found to comply with Part 15 of the FCC Rules.

NOTE:

- a. Any changes or modification not approved by CAEN RFID could void the user's authority to operate the equipment.
- b. The Muon A528B Module, which is rated at 500 mW output, is approved for operation with the following antennas:
 1. CAENRFID antenna Mod. WANTENNAX010 (Linear polarized 3dbi gain PIFA antenna for portable and desktop systems - 915 MHz).
 2. Antenova mod. A10315 (Reflexus Penta-band SMD Antenna; 2dBi gain).

Use of other than the approved antennas with this unit may result in harmful interference with other users, and cause the unit to fail to meet regulatory requirements. The maximum allowed antenna gain to be used with A528B module is 3dBi.

- c. This transmitter module is authorized to be used in other devices only by OEM integrators under the following conditions:
 1. The RFID Module antenna shall have a separation distance of at least 20 cm from all persons
 2. The transmitter module must not be co-located with any other antenna or transmitter
- d. In case that the two conditions above are met, further transmitter testing will not be necessary. However, the OEM integrator is still responsible for testing the end-product for any additional compliance requirements required with this module installed (for example, digital device emissions, PC peripheral requirements, etc.). In the event that these conditions can not be met (for certain configurations or co-location with another transmitter), then the FCC authorization is no longer considered valid and the FCC ID can not be used on the final product. In such case the OEM integrator will be responsible for re-evaluating the end product (including the transmitter) and obtaining a separate FCC authorization.
- e. If the FCC ID is not visible when the module is installed inside another device, the OEM integrator shall apply a label in a visible area on his product with the following statement:
Contains Transmitter Module FCC ID: UVECAENRFID016
or
Contains FCC ID: UVECAENRFID016
- f. The OEM integrator has to be aware not to provide information to the end user regarding how to install or remove this RF module or change RF related parameters in the user manual of the end product.

CE Compliance

Reference standard:

CEI EN 60950-1:2007
ETSI EN 301 489-1 V. 1.9.2:2011
ETSI EN 301 489-3 V. 1.4.1:2002
ETSI EN 302 208-2 V. 1.4.1:2011
CEI EN 50364:2011

Reference document: Test report n. 13122 [RD2].

See § *EC Declaration of Conformity* pag. 29 for the Muon A528B CE Compliance Certificate.

RoHS EU Directive

Muon A528B OEM UHF multiregional Compact Reader is compliant with the EU Directive 2002/95/EC on the Restriction of the Use of certain Hazardous Substances in Electrical and Electronic Equipment (RoHS).



Warning: please set up the correct RF regulation of your country following the CAEN RFID instructions.

We

CAEN RFID Srl
Via Vetraia, 11
55049 Viareggio (LU)
Italy
Tel.: +39.0584.388.398 Fax: +39.0584.388.959
Mail: info@caenrfid.com
Web site: www.caenrfid.com

herewith declare under our own responsibility that the product:

Code: WA528BXAAAAA
Description: A528B Muon Compact Embedded UHF RFID Reader

corresponds in the submitted version to the following standards:

CEI EN 60950-1:2007
ETSI EN 301 489-1 V. 1.9.2:2011
ETSI EN 301 489-3 V. 1.4.1:2002
ETSI EN 302 208-2 V. 1.4.1:2011
CEI EN 50364:2011

The present document declares that the specified product complies with the reported standards and satisfies the essential requirements of the European regulation R&TTE Directive 99/5/EC.

Date: 19/03/2013



CAEN RFID Srl
Via Vetraia, 11
55049 VIAREGGIO - ITALY
VAT IT 02032050466

Adriano Bigongiari (Chief Executive Officer)

On the basis of this declaration, this product will bear the following mark:

