

*FCC PART 15, SUBPART B and C  
TEST REPORT*

*for*

VPx 900 MHz ACCESS POINT

MODEL: CM-000250

Prepared for

MESA LABS, INC.  
12100 WEST 6<sup>TH</sup> AVENUE  
LAKEWOOD, COLORADO 80228

Prepared by: 

KYLE FUJIMOTO

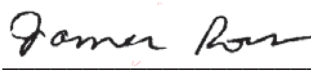
Approved by: 

JAMES ROSS

COMPATIBLE ELECTRONICS INC.  
114 OLINDA DRIVE  
BREA, CALIFORNIA 92823  
(714) 579-0500

DATE: SEPTEMBER 28, 2016

	REPORT BODY	APPENDICES					TOTAL
		A	B	C	D	E	
PAGES	21	2	2	2	19	99	145

This report shall not be reproduced except in full, without the written approval of Compatible Electronics.



## TABLE OF CONTENTS

Section / Title	PAGE
<b>GENERAL REPORT SUMMARY</b>	<b>4</b>
<b>SUMMARY OF TEST RESULTS</b>	<b>5</b>
<b>1. PURPOSE</b>	<b>6</b>
<b>2. ADMINISTRATIVE DATA</b>	<b>7</b>
2.1 Location of Testing	7
2.2 Traceability Statement	7
2.3 Cognizant Personnel	7
2.4 Date Test Sample was Received	7
2.5 Disposition of the Test Sample	7
2.6 Abbreviations and Acronyms	7
<b>3. APPLICABLE DOCUMENTS</b>	<b>8</b>
<b>4. DESCRIPTION OF TEST CONFIGURATION</b>	<b>9</b>
4.1.1 Cable Construction and Termination	10
<b>5. LISTS OF EUT, ACCESSORIES AND TEST EQUIPMENT</b>	<b>11</b>
5.1 EUT and Accessory List	11
<b>6. TEST SITE DESCRIPTION</b>	<b>13</b>
6.1 Test Facility Description	13
6.2 EUT Mounting, Bonding and Grounding	13
<b>7. CHARACTERISTICS OF THE TRANSMITTER</b>	<b>14</b>
7.1 Channel Number and Frequencies	14
7.2 Antenna	14
<b>8. TEST PROCEDURES</b>	<b>15</b>
8.1 RF Emissions	15
8.1.1 Conducted Emissions Test	15
8.1.2 Radiated Emissions Test	16
8.1.3 RF Emissions Test Results	17
8.2 20 dB Bandwidth	18
8.3 Peak Output Power	18
8.4 RF Antenna Conducted Test	18
8.5 RF Band Edges	19
8.6 Carrier Frequency Separation	19
8.7 Number of Hopping Frequencies	19
8.8 Average Time of Occupancy Test	19
8.9 Fundamental Field Strength (Duty Cycle Calculations)	20
8.10 Variation of the Input Power	20
<b>9. CONCLUSIONS</b>	<b>21</b>

**LIST OF APPENDICES**

<b>APPENDIX</b>	<b>TITLE</b>
A	Laboratory Accreditations and Recognitions
B	Modifications to the EUT
C	Additional Models Covered Under This Report
D	Diagrams and Charts <ul style="list-style-type: none"><li>• Test Setup Diagrams</li><li>• Antenna and Effective Gain Factors</li></ul>
E	Data Sheets

**LIST OF FIGURES**

<b>FIGURE</b>	<b>TITLE</b>
1	Conducted Emissions Test Setup
2	Layout of the Semi-Anechoic Test Chamber

---

## GENERAL REPORT SUMMARY

This electromagnetic emission test report is generated by Compatible Electronics Inc., which is an independent testing and consulting firm. The test report is based on testing performed by Compatible Electronics personnel according to the measurement procedures described in the test specifications given below and in the "Test Procedures" section of this report.

The measurement data and conclusions appearing herein relate only to the sample tested and this report may not be reproduced without the written permission of Compatible Electronics, unless done so in full.

This report must not be used to claim product certification, approval or endorsement by NVLAP, NIST or any agency of the federal government.

Device Tested: VPx 900 MHz Access Point  
Model: CM-000250  
S/N: N/A

Product Description: The EUT a part of a wireless sensor system to monitor the storage of vaccines.

Modifications: The EUT was not modified in order to meet the specifications.

Customer: Mesa Labs, Inc.  
12100 West 6th Avenue  
Lakewood, Colorado 80228

Test Dates: July 27, 28, and 31, 2016; and August 29, 2016

Test Specification covered by accreditation:



Test Specifications: Emissions requirements  
CFR Title 47, Part 15, Subpart B; and Subpart C, sections 15.205, 15.207, 15.209, and 15.247

Test Procedure: ANSI C63.4, ANSI C63.10

Test Deviations: The test procedure was not deviated from during the testing.

**SUMMARY OF TEST RESULTS**

<b>TEST</b>	<b>DESCRIPTION</b>	<b>RESULTS</b>
1	Conducted RF Emissions, 150 kHz - 30 MHz	Complies with the <b>Class B</b> limits of CFR Title 47, Part 15, Subpart B; and the limits of CFR Title 47, Part 15, Subpart C, section 15.207. Highest reading in relation to spec limit: 24.44 dBuV @ 0.290 MHz (*U = 2.86 dB)
2	Radiated RF Emissions, 10 kHz – 9300 MHz	Complies with the <b>Class B</b> limits of CFR Title 47, Part 15, Subpart B; and the limits of CFR Title 47, Part 15 Subpart C, 15.205, 15.209 and 15.247 (d) Highest reading in relation to spec limit: 44.94 dBuV @ 2706.75 MHz (*U = 3.70 dB)
3	20 dB Bandwidth	Complies with the relevant requirements of CFR Title 47, Part 15, Subpart C, section 15.247 (a)(1)(i)
4	Peak Power Output	Complies with the relevant requirements of FCC Title 47, Part 15, Subpart C, section 15.247 (b)(2)
5	RF Conducted Antenna Test	Complies with the relevant requirements of FCC Title 47, Part 15, Subpart C, section 15.247 (d)
6	Carrier Frequency Separation	Complies with the relevant requirements of CFR Title 47, Part 15, Subpart C, section 15.247 (a)(1)
7	Average Time of Occupancy	Complies with the relevant requirements of CFR Title 47, Part 15, Subpart C, section 15.247 (a)(1)(i)
8	Peak Power Spectral Density from the International Radiator to the Antenna	This test was not performed because the EUT is a frequency hopper.

**1. PURPOSE**

This document is a qualification test report based on the emissions tests performed on the VPx 900 MHz Access Point, Model: CM-000250. The emissions measurements were performed according to the measurement procedure described in ANSI C63.4 and ANSI C63.10. The tests were performed in order to determine whether the electromagnetic emissions from the equipment under test, referred to as EUT hereafter, are within the Class B specification limits defined by CFR Title 47, Part 15, Subpart B; and Subpart C, sections 15.205, 15.207, 15.209, and 15.247.



## 2. ADMINISTRATIVE DATA

### 2.1 Location of Testing

The emissions tests described herein were performed at the test facility of Compatible Electronics, 114 Olinda Drive, Brea, California 92823.

### 2.2 Traceability Statement

The calibration certificates of all test equipment used during the test are on file at the location of the test. The calibration is traceable to the National Institute of Standards and Technology (NIST).

### 2.3 Cognizant Personnel

Mesa Labs, Inc.

Al Murphy

Director of Engineering – Hardware

Compatible Electronics Inc.

Kyle Fujimoto

Test Engineer

James Ross

Test Engineer

### 2.4 Date Test Sample was Received

The test sample was received on May 18, 2016.

### 2.5 Disposition of the Test Sample

The test sample has not been returned to Mesa Labs, Inc. as of the date of this test report.

### 2.6 Abbreviations and Acronyms

The following abbreviations and acronyms may be used in this document.

RF	Radio Frequency
EMI	Electromagnetic Interference
EUT	Equipment Under Test
P/N	Part Number
S/N	Serial Number
HP	Hewlett Packard
ITE	Information Technology Equipment
LISN	Line Impedance Stabilization Network
N/A	Not Applicable
Tx	Transmit
Rx	Receive

### 3. APPLICABLE DOCUMENTS

The following documents are referenced or used in the preparation of this emissions Test Report.

<b>SPEC</b>	<b>TITLE</b>
FCC Title 47, Part 15 Subpart C	FCC Rules – Radio frequency devices (including digital devices) – Intentional Radiators
FCC Title 47, Part 15 Subpart B	FCC Rules – Radio frequency devices (including digital devices) – Unintentional Radiators
EN 50147-2: 1997	Anechoic chambers. Alternative test site suitability with respect to site attenuation
ANSI C63.4 2014	American National Standard for Methods of Measurement of Radio-Noise Emissions from Low-Voltage Electrical and Electronic Equipment in the Range of 9 kHz to 40 GHz
ANSI C63.10 2013	American National Standard for Testing Unlicensed Wireless Devices



#### 4. DESCRIPTION OF TEST CONFIGURATION

The VPx 900 MHz Access Point, Model: CM-000250 (EUT) was connected to a router and power supply via its ethernet and power ports, respectively.

**For configuring the EUT for the intentional radiator portion of the test:** The EUT was connected to a laptop that had a program that locked one channel at a time so that the low, middle, and high channels could be tested. The EUT was tested in three orthogonal axis. The carrier was modulated in the same way it would be when the EUT was in its normal operating mode.

**For configuring the EUT for the unintentional radiator and conducted emission portion of the test:** The EUT was connected to a laptop that allowed the EUT to function as normal. The laptop also had a program that locked on channel at a time so that the low, middle, and high channels of the LO of the Rx could be tested.

**Note:** The laptop was only connected to the EUT to program the correct configuration and then was removed during the testing.

The X-Axis is when the EUT is parallel to the ground reference plane. The Y-Axis is when the EUT is perpendicular to the ground reference plane. The Z-Axis is when the front of the EUT is rotated 90 degrees and perpendicular to the ground reference plane.

The EUT was fully tested with a Model: HG903RD-RSP L-Com antenna and a P/N: W1063 Pulse antenna.

The final radiated data for the EUT as well as the conducted data was taken in the modes described above. Please see Appendix E for the data sheets.

#### 4.1.1 Cable Construction and Termination

##### Cable 1

This is a 2-meter unshielded cable connecting the power supply to the EUT. The cable is hard wired at the power supply end and has a 1/8 inch power connector at the EUT end. The cable was bundled to a length of 1-meter. The cable has a molded ferrite at the power supply end.

##### Cable 2

This is a 16.67-meter unshielded cable connecting the EUT to the router. The cable has an RJ-45 connector at each end.

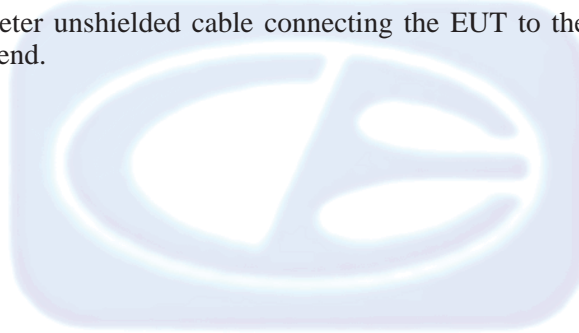

**5. LISTS OF EUT, ACCESSORIES AND TEST EQUIPMENT****5.1 EUT and Accessory List**

<b>EQUIPMENT</b>	<b>MANUFACTURER</b>	<b>MODEL NUMBER</b>	<b>SERIAL NUMBER</b>	<b>FCC ID</b>
VPx 900 MHz Access Point	MESA LABS, INC.	CM-000250	N/A	UUYVPX900AP
POWER SUPPLY FOR VPx 900 MHz ACCESS POINT	CUI, INC.	EPSA06020UU	LF1R02150100376	N/A
AC ADAPTER FOR LAPTOP	HEWLETT PACKARD	PPP012D-S	WCNXF0ACX3OCXS	N/A
LAPTOP	HEWLETT PACKARD	PROBOOK 6560B	N/A	N/A
ROUTER	NETGEAR	FS105	1D52373709041	DoC
ANTENNA FOR EUT	PULSE	P/N: W1063	N/A	N/A
ANETNNA FOR EUT	L-COM	HG903RD-RSP	N/A	N/A

**5.2 Emissions Test Equipment**

EQUIPMENT TYPE	MANUFACTURER	MODEL NUMBER	SERIAL NUMBER	CALIBRATION DATE	CAL. CYCLE
<b>GENERAL TEST EQUIPMENT USED IN LAB D</b>					
TDK TestLab	TDK RF Solutions, Inc.	9.22	700145	N/A	N/A
Computer	Hewlett Packard	p6716f	MXX1030PX0	N/A	N/A
LCD Monitor	Hewlett Packard	52031a	3CQ046N3MG	N/A	N/A
EMI Receiver	Keysight	N9038A	MY51210150	December 29, 2015	1 Year
<b>RF RADIATED EMISSIONS TEST EQUIPMENT</b>					
CombiLog Antenna	Com-Power	AC-220	61060	September 3, 2015	2 Year
Preamplifier	Com-Power	PAM-118A	551024	May 12, 2016	1 Year
Loop Antenna	Com-Power	AL-130	17089	February 6, 2015	2 Year
Horn Antenna	Com-Power	AH-118	071175	February 26, 2016	2 Year
Antenna Mast	Com Power	AM-100	N/A	N/A	N/A
System Controller	Sunol Sciences Corporation	SC110V	112213-1	N/A	N/A
Turntable	Sunol Sciences Corporation	2011VS	N/A	N/A	N/A
Antenna-Mast	Sunol Sciences Corporation	TWR95-4	112213-3	N/A	N/A
<b>RF CONDUCTED EMISSIONS TEST EQUIPMENT</b>					
LISN	Com-Power	LI-215A	191951	June 9, 2015	2 Year
Transient Limiter	Com-Power	252A910	N/A	October 14, 2015	1 Year
<b>VARIATION OF THE INPUT POWER TEST EQUIPMENT</b>					
Variable Auto Transformer	Staco Energy Products	3PN1010	N/A	N/A	N/A
Multimeter	Fluke	87	58450372	March 17, 2016	1 Year

**6. TEST SITE DESCRIPTION****6.1 Test Facility Description**

Please refer to section 2.1 and 7.1 of this report for emissions test location.

**6.2 EUT Mounting, Bonding and Grounding**

**For frequencies 1 GHz and below:** The EUT was mounted on a 1.0 by 1.5 meter non-conductive table 0.8 meters above the ground plane.

**For frequencies above 1 GHz:** The EUT was mounted on a 1.0 by 1.5 meter non-conductive table 1.5 meters above the ground plane.

The EUT was not grounded.

## 7. CHARACTERISTICS OF THE TRANSMITTER

The following sections describe the test methods and the specifications for the tests. Test results are also included in this section.

### 7.1 Channel Number and Frequencies

The FHSS uses at least a minimum of 50 channels minimum using a pseudo random technique. It uses GFSK modulation. The channels are separated by approximately 250 kHz.

The three subbands that the EUT can operate on are:

1. 906.12 MHz to 924.12 MHz, which contains 60 channels
2. 902.62 MHz to 914.87 MHz, which contains 50 channels
3. 914.87 MHz to 927.62 MHz, which contains 52 channels

See Appendix E for the each plot showing the total number of channels in each subband.

### 7.2 Antenna

The EUT can be used with a Model: HG903RD-RSP L-Com antenna and a P/N: W1063 Pulse antenna.

## 8. TEST PROCEDURES

The following sections describe the test methods and the specifications for the tests. Test results are also included in this section.

### 8.1 RF Emissions

#### 8.1.1 Conducted Emissions Test

The EMI Receiver was used as a measuring meter. A quasi-peak and/or average reading was taken only where indicated in the data sheets. A transient limiter was used for the protection of the EMI Receiver input stage, and the offset was adjusted accordingly to read the actual data measured. The LISN output was measured using the EMI Receiver. The output of the second LISN was terminated by a 50-ohm termination. The effective measurement bandwidth used for this test was 9 kHz.

Please see section 6.2 of this report for mounting, bonding, and grounding of the EUT. The EUT was powered through the LISN, which was bonded to the ground plane. The LISN power was filtered and the filter was bonded to the ground plane. The EUT was set up with the minimum distances from any conductive surfaces as specified in ANSI 63:4. The excess power cord was wrapped in a figure eight pattern to form a bundle not exceeding 0.4 meters in length.

The conducted emissions from the EUT were maximized for operating mode as well as cable placement. The final data was collected under program control by computer software. The final qualification data is located in Appendix E.

The EUT was tested at 120 VAC. The six highest emissions are listed in Table 1.0.

#### **Test Results:**

The EUT complies with the **Class B** limits of CFR Title 47, Part 15, Subpart B; and the limits of CFR Title 47, Part 15, Subpart C, Section 15.207 for conducted emissions. Please see Appendix E for the data sheets.

### 8.1.2 Radiated Emissions Test

The EMI Receiver was used as the measuring meter. A built-in, internal preamplifier was used to increase the sensitivity of the instrument. The EMI Receiver was initially used with the Analyzer mode feature activated. In this mode, the EMI receiver can then record the actual frequency to be measured. This final reading is then taken accurately in the EMI Receiver mode, which takes into account the cable loss, amplifier gain and antenna factors, so that a true reading is compared to the true limit. A quasi-peak reading was taken only for those readings, which are marked accordingly on the data sheets. The effective measurement bandwidth used for the radiated emissions test was according to the frequency measured (200 Hz for 10 kHz to 150 kHz, 9 kHz for 150 kHz to 30 MHz, 120 kHz for 30 MHz to 1 GHz and 1 MHz for 1 GHz to 9.3 GHz).

The frequencies above 1 GHz were averaged by using duty cycle correction factor.

The EMI test chamber of Compatible Electronics, Inc. was used for radiated emissions testing. This test site is in full compliance with ANSI C63.4, EN 50147-2 and CISPR 22. Please see section 6.2 of this report for mounting, bonding and grounding of the EUT. The turntable supporting the EUT is remote controlled using a motor. The turntable permits EUT rotation of 360 degrees in order to maximize emissions. Also, the antenna mast allows height variation of the antenna from 1 meter to 4 meters. Data was collected in the worst case (highest emission) configuration of the EUT. At each reading, the EUT was rotated 360 degrees and the antenna height was varied from 1 to 4 meters (for E field radiated field strength). The gunsight method was used when measuring with the horn antenna in order to ensure accurate results.

The EUT was tested at a 3-meter test distance. The six highest emissions are listed in Table 2.0.

The measurement bandwidths and transducers used for the radiated emissions test were:

FREQUENCY RANGE	EFFECTIVE MEASUREMENT BANDWIDTH	TRANSDUCER
10 kHz to 150 kHz	200 Hz	Loop Antenna
150 kHz to 30 MHz	9 kHz	Loop Antenna
30 MHz to 1 GHz	120 kHz	CombiLog Antenna
1 GHz to 9.3 GHz	1 MHz	Horn Antenna

#### Test Results:

The EUT complies with the **Class B** limits of **CFR** Title 47, Part 15, Subpart B; and Subpart C sections 15.205, 15.209, and 15.247 (d) for radiated emissions.



### 8.1.3 RF Emissions Test Results

Table 1.0 CONDUCTED EMISSION RESULTS  
 VPx 900 MHz Access Point  
 Models: CM-000250

Frequency MHz	Average Corrected Reading* dBuV	Average Specification Limit dBuV	Delta (Cor. Reading – Spec. Limit) dB
0.710 (BL) (Tx) (L-COM)	41.70 (Average)	46.00	-4.30
0.718 (BL) (Tx) (Pulse)	41.69 (Average)	46.00	-4.31
0.714 (WL) (Tx) (Pulse)	41.65 (Average)	46.00	-4.35
0.706 (WL) (Tx) (Pulse)	41.64 (Average)	46.00	-4.36
0.718 (WL) (Tx) (Pulse)	41.64 (Average)	46.00	-4.36
0.726 (WL) (Tx) (L-COM)	41.61 (Average)	46.00	-4.39

Table 2.0 RADIATED EMISSION RESULTS  
 VPx 900 MHz Access Point  
 Models: CM-000250

Frequency MHz	EMI Reading (dBuV)	Specification Limit (dBuV)	Delta (Cor. Reading – Spec. Limit) dB
132.10 (V) (L-COM) (Tx)	42.42 (QP)	43.50	-1.08
250.00 (H) (Pulse) (Digital Mode)	55.02 (QP)	56.89	-1.87
125.00 (H) (L-COM)	41.43 (QP)	43.50	-2.07
250.00 (V) (L-COM)	43.49 (QP)	46.00	-2.51
150.00 (V)(Pulse)	40.90 (QP)	46.00	-2.60
150.00 (V) (L-COM)	40.67 (QP)	43.50	-2.83

Notes:

- \* The complete emissions data is given in Appendix E of this report.
- (BL) Black Lead
- (WL) White Lead
- (V) Vertical
- (H) Horizontal
- (QP) Quasi-Peak

## 8.2 20 dB Bandwidth

The 20 dB Bandwidth was measured using the EMI Receiver. The bandwidth was measured using a direct connection from the RF output of the EUT. The resolution bandwidth was  $\geq 1\%$  of the bandwidth and the video bandwidth was  $\geq$  RBW.

### Test Results:

The EUT complies with the relevant requirements of FCC Title 47, Part 15, Subpart C section 15.247 (a)(1)(i). The 20 dB bandwidth is less than the separation between channels. Please see the data sheets located in Appendix E.

## 8.3 Peak Output Power

The Peak Output Power was measured using the EMI Receiver. The peak output power was measured using a direct connection from the RF output of the EUT. The resolution bandwidth was greater than 20 dB bandwidth and the video bandwidth was  $\geq$  RBW. The cable loss was also added back into the reading using the reference level offset.

### Test Results:

The EUT complies with the relevant requirements of FCC Title 47, Part 15, Subpart C section 15.247 (b)(2). The maximum peak output power is less than 1 Watt. Please see the data sheets located in Appendix E.

## 8.4 RF Antenna Conducted Test

The RF antenna conducted test was performed using the EMI Receiver. The RF antenna conducted test measured using a direct connection from the RF out on the EUT into the input of the EMI Receiver. The resolution bandwidth was 100 kHz, and the video bandwidth was 300 kHz. The spans were wide enough to include all the harmonics and emissions that were produced by the intentional radiator.

### Test Results:

The EUT complies with the relevant requirements of FCC Title 47, Part 15, Subpart C section 15.247 (d). The RF power that is produced by the intentional radiator is at least 20 dB below that in the 100 kHz bandwidth within the band that contains the highest level of desired power. Please see the radiated emission data sheets located in Appendix E.

## 8.5 RF Band Edges

The RF band edges were taken at the edges of the ISM spectrum (902 MHz when the EUT was on the low channel and 928 MHz when the EUT was on the high channel) using the EMI Receiver. The RBW was set to 100 kHz and the VBW was set to 300 kHz. Plots of the fundamental were taken to ensure the amplitude at the band edges were at least 20 dB down from the peak of the fundamental emission. The plots were taken in both frequency hopping mode and single channel mode.

### Test Results:

The EUT complies with the relevant requirements of FCC Title 47, Part 15, Subpart C section 15.247 (d). The RF power at the band edges at 902 MHz and 928 MHz meet the requirements of FCC Title 47, Part 15, Subpart C section 15.247 (d). Please see the data sheets located in Appendix E.

## 8.6 Carrier Frequency Separation

The Channel Hopping Separation Test was measured using the EMI Receiver. The EUT was operating in its normal operating mode. The resolution bandwidth was approximately 30% of the channel spacing, and the video bandwidth  $\geq$  RBW. The frequency span was wide enough to include the peaks of two adjacent channels.

### Test Results:

The EUT complies with the relevant requirements of FCC Title 47, Part 15, Subpart C section 15.247 (a)(1). The Channel Hopping Separation is greater than the 20 dB bandwidth. Please see the data sheets located in Appendix E.

## 8.7 Number of Hopping Frequencies

The Number of Hopping Frequencies was measured using the EMI Receiver. The EUT was operating in its normal operating mode. The resolution bandwidth was set to approximately 30% of the channel spacing, and the video bandwidth was  $\geq$  RBW. The frequency span was wide enough to include all of the peaks in the frequency band of operation.

### Test Results:

The EUT complies with the relevant requirements of FCC Title 47, Part 15, Subpart C section 15.247 (a)(1) and 15.247 (a)(1)(i). Please see the data sheets located in Appendix E.

## 8.8 Average Time of Occupancy Test

The Average Time of Occupancy Test was measured using the EMI Receiver. The EUT was operating in normal operating mode. The frequency span was taken to 0 Hz to determine the time for each transmission and the number of transmissions over a 20 second period. The RBW was set to be less than the channel spacing. The low hop band table was determined to be the worst case because this mode results in the pulses appearing more frequently.

### Test Results:

The EUT complies with the relevant requirements of FCC Title 47, Part 15, Subpart C section 15.247 (a)(1)(i). Please see the data sheets located in Appendix E.

## 8.9 Fundamental Field Strength (Duty Cycle Calculations)

The Peak Transmit Radiated Field Strength was measured at a 3-meter test distance. The EMI Receiver was used to obtain the duty cycle. The data sheets are located in Appendix E.

Where

$$\delta(\text{dB}) = 20 \log \left[ \frac{\sum (nt_1 + mt_2 + \dots + \xi t_x)}{T} \right]$$

$n$  is the number of pulses of duration  $t_1$

$m$  is the number of pulses of duration  $t_2$

$\xi$  is the number of pulses of duration  $t_x$

$T$  is the period of the pulse train or 100 ms if the pulse train length is greater than 100 ms

Duty Cycle Correction Factor = -20.00dB

Pulse = 1 \* 6.5 mS

Total On Time = 6.5 mS

Duty Cycle Train was longer than 100mS; therefore 100mS span was used.

6.5 mS / 100 mS = 6.5%

20 log (0.09) = -20.92 dB correction factor

**Max Duty Cycle Correction Factor = -20.00dB**

## 8.10 Variation of the Input Power

The variation of the input power test was performed using the EMI Receiver. The EUT input power was varied between 85% and 115% of the nominal rated supply voltage. The carrier frequency was monitored for any change in amplitude.

### Test Results:

The EUT complies with the relevant requirements of FCC Title 47, Part 15, Subpart C section 15.31(e).

## 9. CONCLUSIONS

The VPx 900 MHz Access Point, Model: CM-000250, as tested, meets all of the specification limits defined in FCC Title 47, Part 15, Subpart B; and Subpart C, sections 15.205, 15.207, 15.209, and 15.247.





**APPENDIX A**

***LABORATORY ACCREDITATIONS AND RECOGNITIONS***

---

**Brea Division**  
114 Olinda Drive  
Brea, CA 92823  
(714) 579-0500

**Agoura Division**  
2337 Troutdale Drive  
Agoura, CA 91301  
(818) 597-0600

**Silverado Division**  
19121 El Toro Road  
Silverado, CA 92676  
(949) 589-0700

**Lake Forest Division**  
20621 Pascal Way  
Lake Forest, CA 92630  
(949) 587-0400

## LABORATORY ACCREDITATIONS AND RECOGNITIONS



NVLAP LAB CODE 200528-0

® For US, Canada, Australia/New Zealand, Japan, Taiwan, Korea, and the European Union, Compatible Electronics is currently accredited by NVLAP to ISO/IEC 17025.  
**For the most up-to-date version of our scopes and certificates please visit**  
<http://celectronics.com/quality/scope/>

Quote from ISO-ILAC-IAF Communiqué on 17025:

"A laboratory's fulfilment of the requirements of ISO/IEC 17025:2005 means the laboratory meets both the technical competence requirements and management system requirements that are necessary for it to consistently deliver technically valid test results and calibrations. The management system requirements in ISO/IEC 17025:2005 (Section 4) are written in language relevant to laboratory operations and meet the principles of ISO 9001:2008 Quality Management Systems — Requirements."

ANSI listing [CETCB](#)

Compatible Electronics has been nominated as a Conformity Assessment Body (CAB) for EMC under the US/EU Mutual Recognition Agreement (MRA).

US/EU MRA list [NIST MRA site](#)

Compatible Electronics has been nominated as a Conformity Assessment Body (CAB) for Taiwan/BSMI under the US/APEC (Asia-Pacific Economic Cooperation) Mutual Recognition Agreement (MRA).

APEC MRA list [NIST MRA site](#)

We are also listed for IT products by the following country/agency:

VCCI Support member: Please visit [http://www.vcci.jp/vcci\\_e/](http://www.vcci.jp/vcci_e/)FCC Listing, from FCC OET site  
[FCC test lab search](https://fjallfoss.fcc.gov/oetcf/eas/reports/TestFirmSearch.cfm) <https://fjallfoss.fcc.gov/oetcf/eas/reports/TestFirmSearch.cfm>

Compatible Electronics IC listing can be found at:  
<http://www.ic.gc.ca/eic/site/ic1.nsf/eng/home>

**APPENDIX B**

***MODIFICATIONS TO THE EUT***



---

## **MODIFICATIONS TO THE EUT**

The modifications listed below were made to the EUT to pass FCC Subpart B and FCC 15.247 specifications.

All the rework described below was implemented during the test in a method that could be reproduced in all the units by the manufacturer.

No modifications were made to the EUT during the testing.



**APPENDIX C**

***ADDITIONAL MODELS COVERED  
UNDER THIS REPORT***

---

**Brea Division**  
114 Olinda Drive  
Brea, CA 92823  
(714) 579-0500

**Agoura Division**  
2337 Troutdale Drive  
Agoura, CA 91301  
(818) 597-0600

**Silverado Division**  
19121 El Toro Road  
Silverado, CA 92676  
(949) 589-0700

**Lake Forest Division**  
20621 Pascal Way  
Lake Forest, CA 92630  
(949) 587-0400

## **ADDITIONAL MODELS COVERED UNDER THIS REPORT**

USED FOR THE PRIMARY TEST

VPx 900 MHz Access Point  
Models: CM-000250  
S/N: N/A

There are no additional models covered under this report.



**APPENDIX D**

***DIAGRAMS AND CHARTS***

**FIGURE 1: CONDUCTED EMISSIONS TEST SETUP**

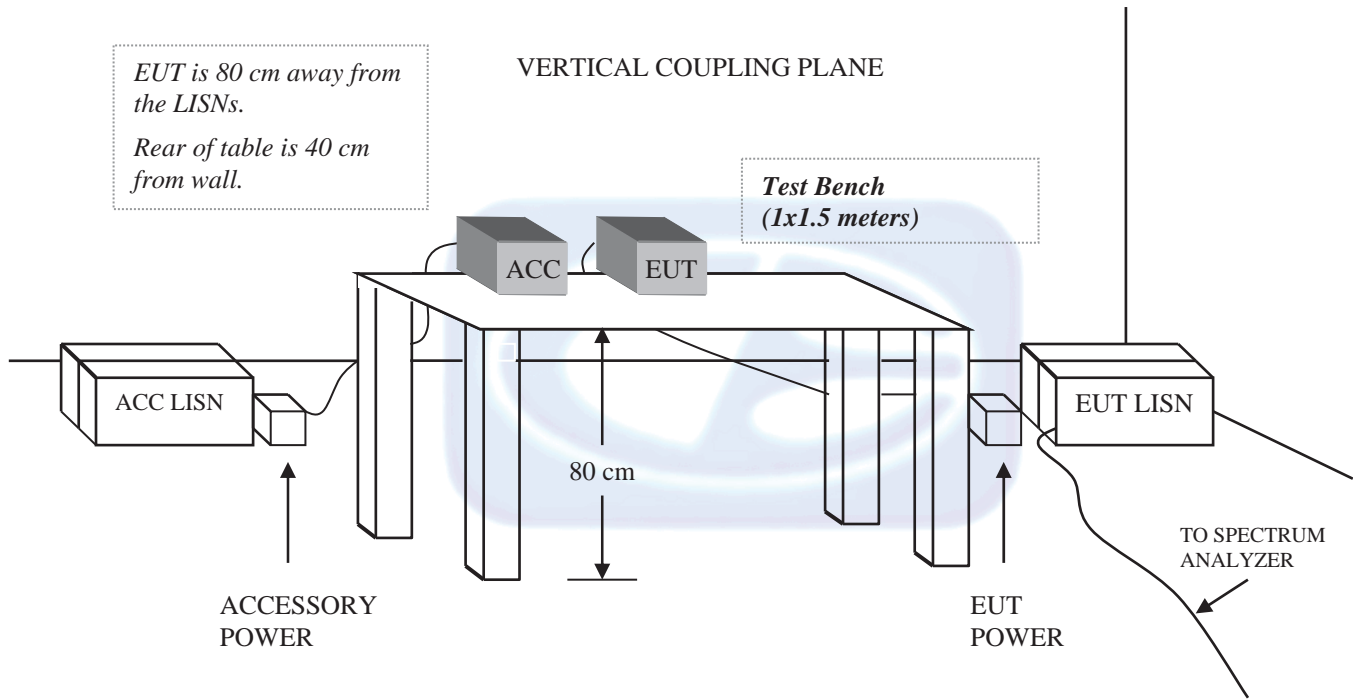

**FIGURE 2: LAYOUT OF THE SEMI MI-ANECHOIC TEST CHAMBER**

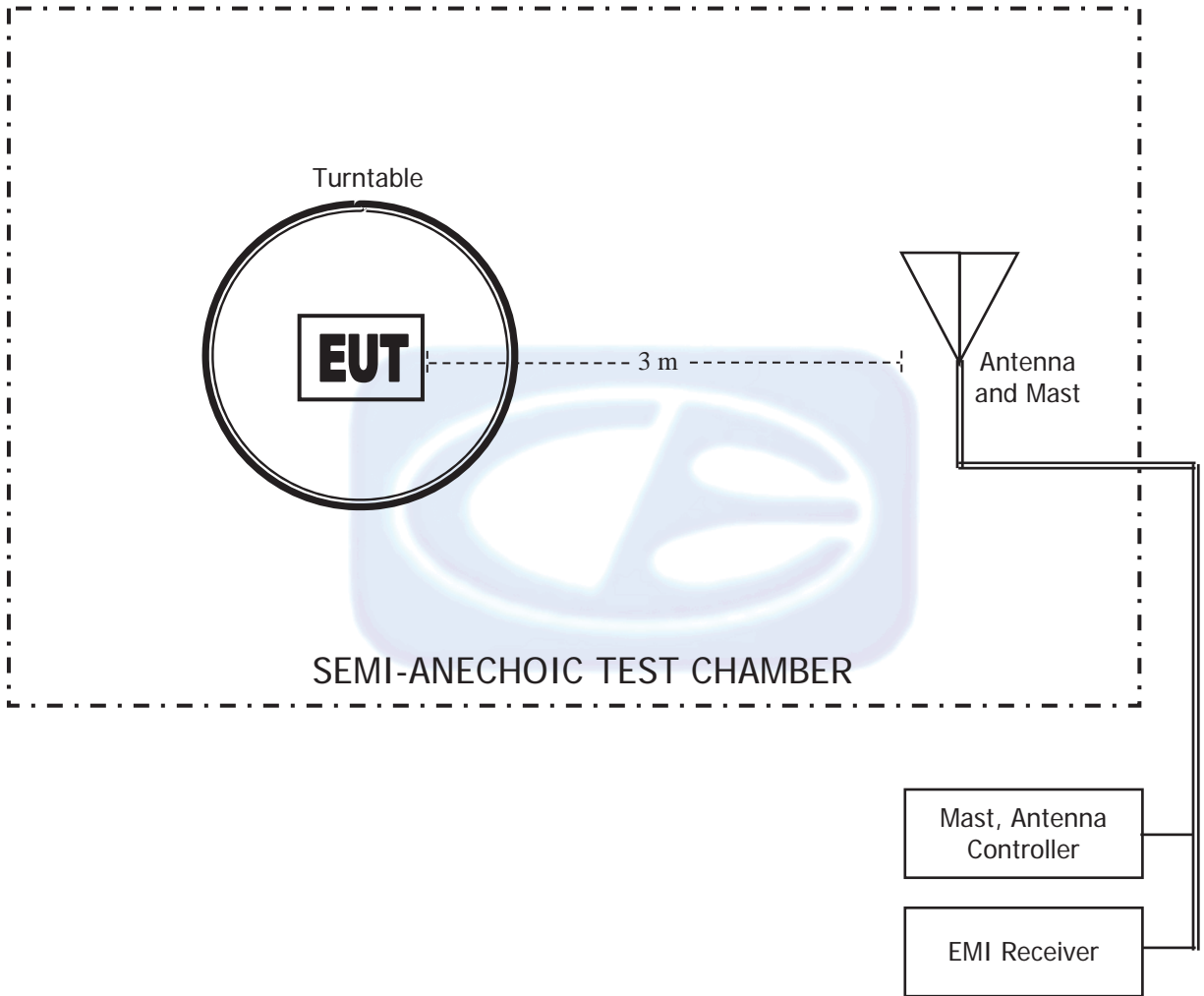

**COM-POWER AL-130****LOOP ANTENNA**

S/N: 17089

CALIBRATION DATE: FEBRUARY 6, 2015

<b>FREQUENCY (MHz)</b>	<b>MAGNETIC (dB/m)</b>	<b>ELECTRIC (dB/m)</b>
0.009	-33.18	18.32
0.01	-34.10	17.40
0.02	-38.65	12.85
0.03	-39.28	12.22
0.04	-40.09	11.41
0.05	-40.85	10.65
0.06	-40.88	10.62
0.07	-41.07	10.43
0.08	-41.04	10.46
0.09	-41.19	10.31
0.1	-41.20	10.30
0.2	-41.52	9.98
0.3	-41.53	9.97
0.4	-41.42	10.08
0.5	-41.53	9.97
0.6	-41.53	9.97
0.7	-41.43	10.07
0.8	-41.23	10.27
0.9	-41.13	10.37
1	-41.14	10.36
2	-40.80	10.70
3	-40.66	10.84
4	-40.61	10.89
5	-40.33	11.17
6	-40.53	10.97
7	-40.47	11.03
8	-40.48	11.02
9	-39.93	11.57
10	-39.81	11.69
15	-43.35	8.15
20	-39.16	12.34
25	-40.24	11.26
30	-43.18	8.32

**COM-POWER AC-220****COMBILOG ANTENNA**

S/N: 61060

CALIBRATION DATE: SEPTEMBER 3, 2015

<b>FREQUENCY (MHz)</b>	<b>FACTOR (dB)</b>	<b>FREQUENCY (MHz)</b>	<b>FACTOR (dB)</b>
30	24.00	200	13.00
35	24.30	250	15.30
40	25.40	300	18.20
45	21.50	350	17.90
50	22.50	400	18.60
60	15.40	450	19.80
70	12.70	500	21.60
80	11.10	550	22.40
90	13.40	600	23.70
100	13.80	650	24.30
120	15.40	700	24.00
125	15.40	750	24.50
140	13.10	800	24.30
150	17.20	850	26.30
160	13.20	900	26.90
175	14.20	950	26.00
180	14.30	1000	25.60



**COM POWER AH-118****HORN ANTENNA**

S/N: 071175

CALIBRATION DATE: FEBRUARY 26, 2016

<b>FREQUENCY (GHz)</b>	<b>FACTOR (dB)</b>	<b>FREQUENCY (GHz)</b>	<b>FACTOR (dB)</b>
1.0	23.93	10.0	39.33
1.5	25.54	10.5	39.64
2.0	28.09	11.0	41.04
2.5	30.21	11.5	44.29
3.0	30.15	12.0	41.22
3.5	30.17	12.5	41.50
4.0	31.90	13.0	41.62
4.5	33.51	13.5	40.63
5.0	33.87	14.0	39.94
5.5	35.08	14.5	41.84
6.0	34.81	15.0	42.69
6.5	34.26	15.5	39.03
7.0	36.33	16.0	39.07
7.5	37.03	16.5	41.40
8.0	37.56	17.0	43.18
8.5	40.07	17.5	47.01
9.0	38.92	18.0	46.48
9.5	38.21		

**COM-POWER PA-118****PREAMPLIFIER**

S/N: 551024

CALIBRATION DATE: MAY 12, 2016

<b>FREQUENCY (GHz)</b>	<b>FACTOR (dB)</b>	<b>FREQUENCY (GHz)</b>	<b>FACTOR (dB)</b>
1.0	39.84	6.0	39.05
1.1	39.40	6.5	38.94
1.2	39.58	7.0	39.25
1.3	39.68	7.5	39.09
1.4	39.91	8.0	39.01
1.5	39.78	8.5	38.60
1.6	39.50	9.0	38.64
1.7	39.81	9.5	39.67
1.8	39.89	10.0	39.30
1.9	39.94	11.0	39.15
2.0	39.57	12.0	39.24
2.5	40.39	13.0	39.49
3.0	40.63	14.0	39.44
3.5	40.80	15.0	39.94
4.0	40.86	16.0	40.09
4.5	39.94	17.0	40.06
5.0	34.47	18.0	39.76
5.5	39.32		



**FRONT VIEW**

MESA LABS, INC.  
VPX 900 MHz ACCESS POINT  
MODEL: CM-000250  
FCC SUBPART B AND C – RADIATED EMISSIONS – BELOW 1 GHz – L-COM ANTENNA

**PHOTOGRAPH SHOWING THE EUT CONFIGURATION  
FOR MAXIMUM EMISSIONS**

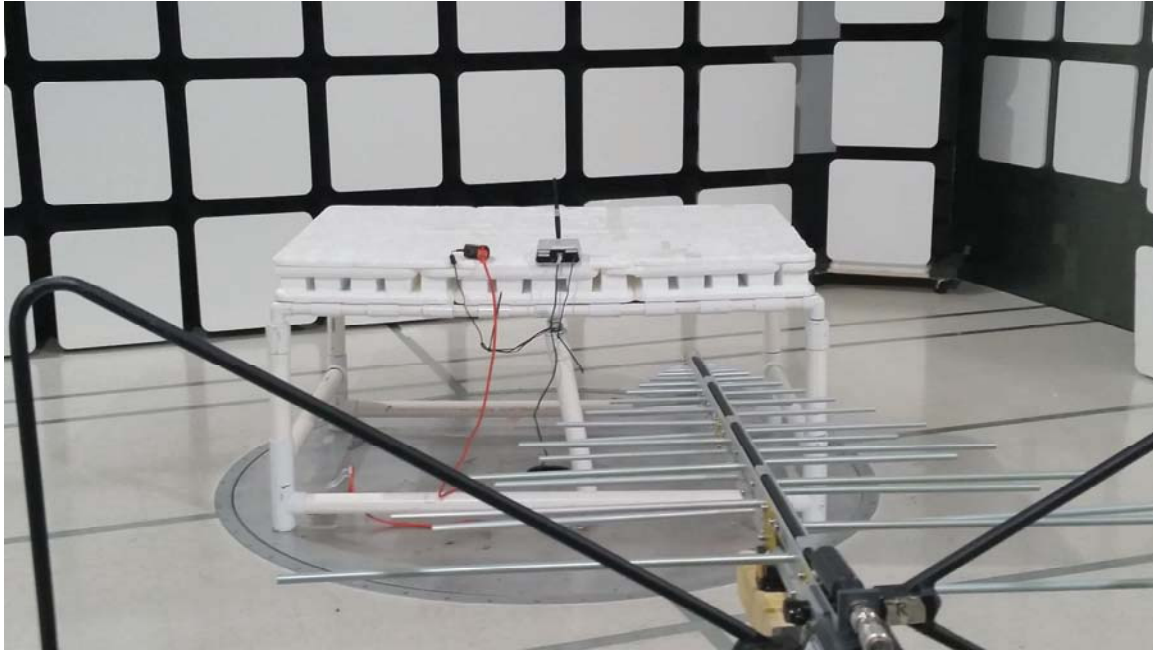

**REAR VIEW**

MESA LABS, INC.  
VPX 900 MHz ACCESS POINT  
MODEL: CM-000250  
FCC SUBPART B AND C – RADIATED EMISSIONS – BELOW 1 GHz – L-COM ANTENNA

**PHOTOGRAPH SHOWING THE EUT CONFIGURATION  
FOR MAXIMUM EMISSIONS**



**FRONT VIEW**

MESA LABS, INC.  
VPX 900 MHz ACCESS POINT  
MODEL: CM-000250  
FCC SUBPART B AND C – RADIATED EMISSIONS – BELOW 1 GHz – PULSE ANTENNA

**PHOTOGRAPH SHOWING THE EUT CONFIGURATION  
FOR MAXIMUM EMISSIONS**

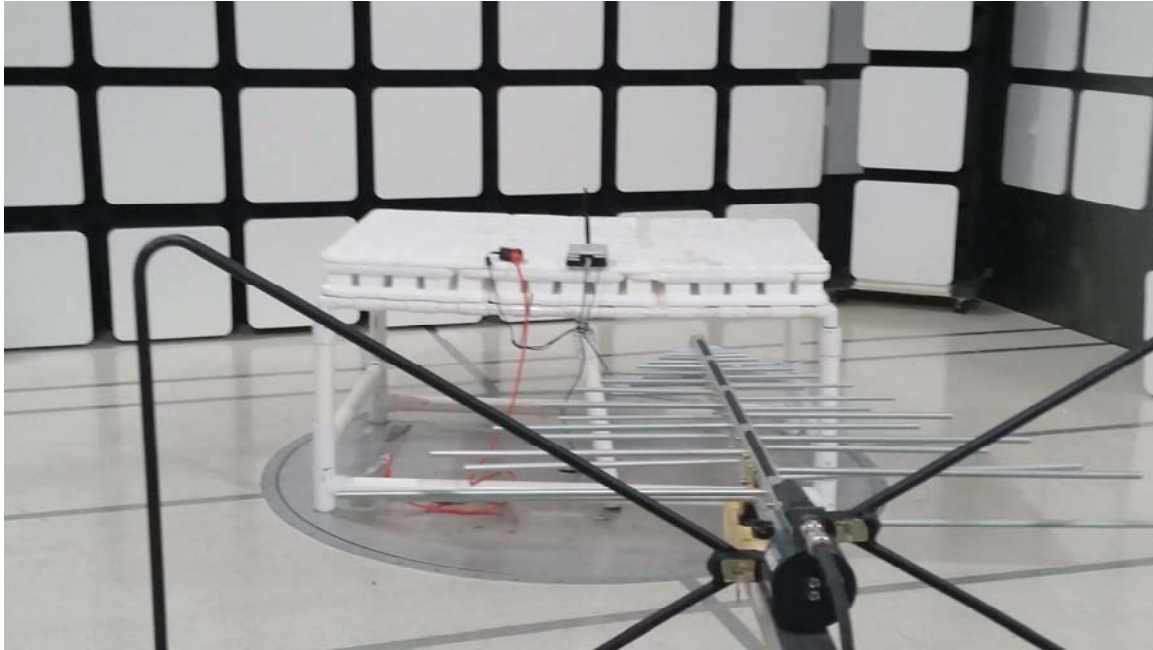

**REAR VIEW**

MESA LABS, INC.  
VPX 900 MHz ACCESS POINT  
MODEL: CM-000250  
FCC SUBPART B AND C – RADIATED EMISSIONS – BELOW 1 GHz – PULSE ANTENNA

**PHOTOGRAPH SHOWING THE EUT CONFIGURATION  
FOR MAXIMUM EMISSIONS**





**FRONT VIEW**

MESA LABS, INC.  
VPx 900 MHz ACCESS POINT  
MODEL: CM-000250  
FCC SUBPART B AND C – CONDUCTED EMISSIONS – L-COM ANTENNA

**PHOTOGRAPH SHOWING THE EUT CONFIGURATION  
FOR MAXIMUM EMISSIONS**



**REAR VIEW**

MESA LABS, INC.  
VPx 900 MHz ACCESS POINT  
MODEL: CM-000250  
FCC SUBPART B AND C – CONDUCTED EMISSIONS – L-COM ANTENNA

**PHOTOGRAPH SHOWING THE EUT CONFIGURATION  
FOR MAXIMUM EMISSIONS**





**FRONT VIEW**

MESA LABS, INC.  
VPx 900 MHz ACCESS POINT  
MODEL: CM-000250  
FCC SUBPART B AND C – CONDUCTED EMISSIONS – PULSE ANTENNA

**PHOTOGRAPH SHOWING THE EUT CONFIGURATION  
FOR MAXIMUM EMISSIONS**



**REAR VIEW**

MESA LABS, INC.  
VPx 900 MHz ACCESS POINT  
MODEL: CM-000250  
FCC SUBPART B AND C – CONDUCTED EMISSIONS – PULSE ANTENNA

**PHOTOGRAPH SHOWING THE EUT CONFIGURATION  
FOR MAXIMUM EMISSIONS**

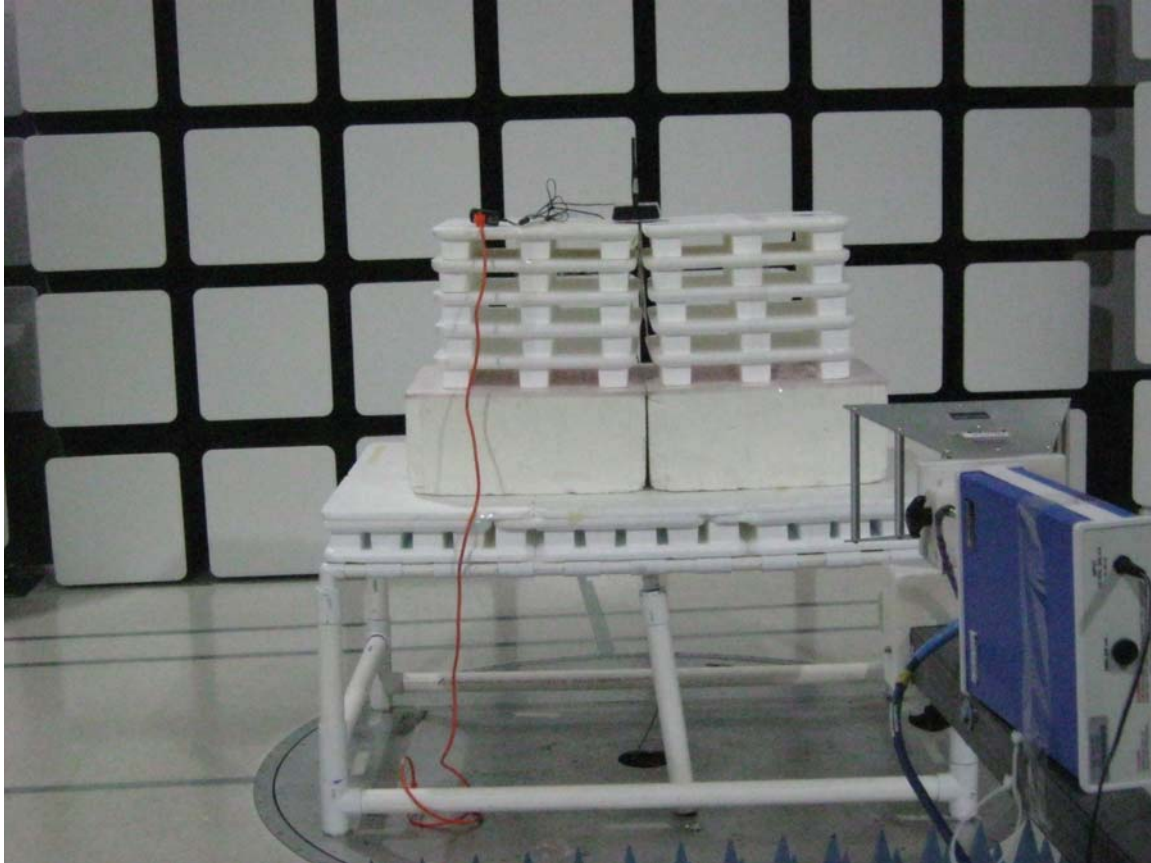

**FRONT VIEW**

MESA LABS, INC.  
VPX 900 MHZ ACCESS POINT  
MODEL: CM-000250

FCC SUBPART B AND C – RADIATED EMISSIONS – L-COM ANTENNA – ABOVE 1 GHz

**PHOTOGRAPH SHOWING THE EUT CONFIGURATION  
FOR MAXIMUM EMISSIONS**





**REAR VIEW**

MESA LABS, INC.  
VPX 900 MHZ ACCESS POINT  
MODEL: CM-000250

FCC SUBPART B AND C – RADIATED EMISSIONS – L-COM ANTENNA – ABOVE 1 GHz

**PHOTOGRAPH SHOWING THE EUT CONFIGURATION  
FOR MAXIMUM EMISSIONS**



**FRONT VIEW**

MESA LABS, INC.  
VPX 900 MHZ ACCESS POINT  
MODEL: CM-000250

FCC SUBPART B AND C – RADIATED EMISSIONS – PULSE ANTENNA – ABOVE 1 GHz

**PHOTOGRAPH SHOWING THE EUT CONFIGURATION  
FOR MAXIMUM EMISSIONS**



**REAR VIEW**

MESA LABS, INC.  
VPX 900 MHZ ACCESS POINT  
MODEL: CM-000250

FCC SUBPART B AND C – RADIATED EMISSIONS – PULSE ANTENNA – ABOVE 1 GHz

**PHOTOGRAPH SHOWING THE EUT CONFIGURATION  
FOR MAXIMUM EMISSIONS**

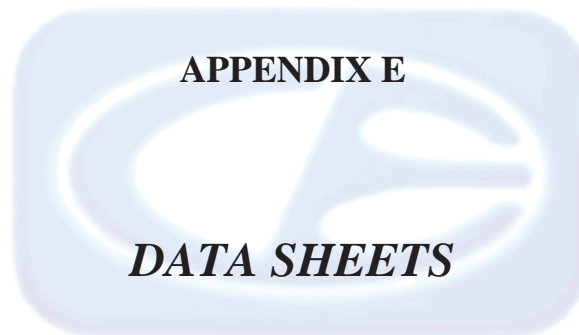



***RADIATED EMISSIONS  
DATA SHEETS***



**FCC 15.247**

Mesa Labs, Inc.  
 VPx 900 MHz Access Point  
 Model: CM-000250

Date: 08/01/2016  
 Lab: D  
 Tested By: Kyle Fujimoto

**L-COM Antenna**  
**Low Channel - X-Axis**  
**Transmit Mode**

Freq. (MHz)	Level (dBuV)	Pol (v/h)	Limit	Margin	Peak / QP / Avg	Table Angle (deg)	Ant. Height (cm)	Comments
1805.24								Not in Restricted Band
1805.24								Done via Conducted
2707.86	56.72	V	73.97	-17.25	Peak	269.00	191.37	
2707.86	36.72	V	53.97	-17.25	Avg	269.00	191.37	
3610.48	52.94	V	73.97	-21.03	Peak	260.75	111.31	
3610.48	32.94	V	53.97	-21.03	Avg	260.75	111.31	
4513.1	62.39	V	73.97	-11.58	Peak	268.50	111.31	
4513.1	42.39	V	53.97	-11.58	Avg	268.50	111.31	
5415.72	52.59	V	73.97	-21.38	Peak	271.00	126.95	
5415.72	32.59	V	53.97	-21.38	Avg	271.00	126.95	
6318.34								Not in Restricted Band
6318.34								Done via Conducted
7220.96								Not in Restricted Band
7220.96								Done via Conducted
8123.58	53.79	V	73.97	-20.18	Peak	223.50	111.25	
8123.58	33.79	V	53.97	-20.18	Avg	223.50	111.25	
9026.2	46.35	V	73.97	-27.62	Peak	204.25	159.25	
9026.2	26.35	V	53.97	-27.62	Avg	204.25	159.25	

**FCC 15.247**

Mesa Labs, Inc.  
 VPx 900 MHz Access Point  
 Model: CM-000250

Date: 08/01/2016  
 Lab: D  
 Tested By: Kyle Fujimoto

**L-COM Antenna**  
**Low Channel - Y-Axis**  
**Transmit Mode**

Freq. (MHz)	Level (dBuV)	Pol (v/h)	Limit	Margin	Peak / QP / Avg	Table Angle (deg)	Ant. Height (cm)	Comments
1805.24								<b>Not in Restricted Band</b>
1805.24								<b>Done via Conducted</b>
2707.86	58.23	V	73.97	-15.74	Peak	276.50	127.25	
2707.86	38.23	V	53.97	-15.74	Avg	276.50	127.25	
3610.48	51.77	V	73.97	-22.20	Peak	130.75	126.77	
3610.48	31.77	V	53.97	-22.20	Avg	130.75	126.77	
4513.1	59.30	V	73.97	-14.67	Peak	324.25	111.97	
4513.1	39.30	V	53.97	-14.67	Avg	324.25	111.97	
5415.72	43.90	V	73.97	-30.07	Peak	210.25	189.76	
5415.72	23.90	V	53.97	-30.07	Avg	210.25	189.76	
6318.34								<b>Not in Restricted Band</b>
6318.34								<b>Done via Conducted</b>
7220.96								<b>Not in Restricted Band</b>
7220.96								<b>Done via Conducted</b>
8123.58	48.51	V	73.97	-25.46	Peak	133.00	250.00	
8123.58	28.51	V	53.97	-25.46	Avg	133.00	250.00	
9026.2	45.00	V	73.97	-28.97	Peak	229.00	239.31	
9026.2	25.00	V	53.97	-28.97	Avg	229.00	239.31	

**FCC 15.247**

Mesa Labs, Inc.  
 VPx 900 MHz Access Point  
 Model: CM-000250  
**L-COM Antenna**  
**Low Channel - Z-Axis**  
**Transmit Mode**

Date: 08/01/2016  
 Lab: D  
 Tested By: Kyle Fujimoto

Freq. (MHz)	Level (dBuV)	Pol (v/h)	Limit	Margin	Peak / QP / Avg	Table Angle (deg)	Ant. Height (cm)	Comments
1805.24								Not in Restricted Band
1805.24								Done via Conducted
2707.86	56.96	V	73.97	-17.01	Peak	159.25	111.43	
2707.86	36.96	V	53.97	-17.01	Avg	159.25	111.43	
3610.48	49.49	V	73.97	-24.48	Peak	169.00	143.13	
3610.48	29.49	V	53.97	-24.48	Avg	169.00	143.13	
4513.1	55.63	V	73.97	-18.34	Peak	155.75	143.37	
4513.1	35.63	V	53.97	-18.34	Avg	155.75	143.37	
5415.72	53.20	V	73.97	-20.77	Peak	0.00	126.89	
5415.72	33.20	V	53.97	-20.77	Avg	0.00	126.89	
6318.34								Not in Restricted Band
6318.34								Done via Conducted
7220.96								Not in Restricted Band
7220.96								Done via Conducted
8123.58	51.46	V	73.97	-22.51	Peak	8.75	111.01	
8123.58	31.46	V	53.97	-22.51	Avg	8.75	111.01	
9026.2	44.62	V	73.97	-29.35	Peak	357.25	190.89	
9026.2	24.62	V	53.97	-29.35	Avg	357.25	190.89	

**FCC 15.247**

Mesa Labs, Inc.  
 VPx 900 MHz Access Point  
 Model: CM-000250

Date: 08/01/2016  
 Lab: D  
 Tested By: Kyle Fujimoto

**L-COM Antenna**  
**Low Channel - X-Axis**  
**Transmit Mode**

Freq. (MHz)	Level (dBuV)	Pol (v/h)	Limit	Margin	Peak / QP / Avg	Table Angle (deg)	Ant. Height (cm)	Comments
1805.24								<b>Not in Restricted Band</b>
1805.24								<b>Done via Conducted</b>
2707.86	37.63	H	73.97	-36.34	Peak	258.25	110.89	
2707.86	17.63	H	53.97	-36.34	Avg	258.25	110.89	
3610.48	47.65	H	73.97	-26.32	Peak	8.25	143.25	
3610.48	27.65	H	53.97	-26.32	Avg	8.25	143.25	
4513.1	59.33	H	73.97	-14.64	Peak	298.25	127.37	
4513.1	39.33	H	53.97	-14.64	Avg	298.25	127.37	
5415.72	47.44	H	73.97	-26.53	Peak	253.00	159.37	
5415.72	27.44	H	53.97	-26.53	Avg	253.00	159.37	
6318.34								<b>Not in Restricted Band</b>
6318.34								<b>Done via Conducted</b>
7220.96								<b>Not in Restricted Band</b>
7220.96								<b>Done via Conducted</b>
8123.58	51.10	H	73.97	-22.87	Peak	304.75	113.10	
8123.58	31.10	H	53.97	-22.87	Avg	304.75	113.10	
9026.2	44.53	H	73.97	-29.44	Peak	134.25	223.31	
9026.2	24.53	H	53.97	-29.44	Avg	134.25	223.31	

**FCC 15.247**

Mesa Labs, Inc.  
 VPx 900 MHz Access Point  
 Model: CM-000250  
**L-COM Antenna**  
**Low Channel - Y-Axis**  
**Transmit Mode**

Date: 08/01/2016  
 Lab: D  
 Tested By: Kyle Fujimoto

Freq. (MHz)	Level (dBuV)	Pol (v/h)	Limit	Margin	Peak / QP / Avg	Table Angle (deg)	Ant. Height (cm)	Comments
1805.24								Not in Restricted Band
1805.24								Done via Conducted
2707.86	54.03	H	73.97	-19.94	Peak	218.25	111.25	
2707.86	34.03	H	53.97	-19.94	Avg	218.25	111.25	
3610.48	49.01	H	73.97	-24.96	Peak	197.50	191.13	
3610.48	29.01	H	53.97	-24.96	Avg	197.50	191.13	
4513.1	62.70	H	73.97	-11.27	Peak	33.75	158.77	
4513.1	42.70	H	53.97	-11.27	Avg	33.75	158.77	
5415.72	54.00	H	73.97	-19.97	Peak	269.50	126.05	
5415.72	34.00	H	53.97	-19.97	Avg	269.50	126.05	
6318.34								Not in Restricted Band
6318.34								Done via Conducted
7220.96								Not in Restricted Band
7220.96								Done via Conducted
8123.58	51.21	H	73.97	-22.76	Peak	155.25	127.25	
8123.58	31.21	H	53.97	-22.76	Avg	155.25	127.25	
9026.2	44.63	H	73.97	-29.34	Peak	346.25	111.01	
9026.2	24.63	H	53.97	-29.34	Avg	346.25	111.01	

**FCC 15.247**

Mesa Labs, Inc.  
 VPx 900 MHz Access Point  
 Model: CM-000250

Date: 08/01/2016  
 Lab: D  
 Tested By: Kyle Fujimoto

**L-COM Antenna**  
**Low Channel - Z-Axis**  
**Transmit Mode**

Freq. (MHz)	Level (dBuV)	Pol (v/h)	Limit	Margin	Peak / QP / Avg	Table Angle (deg)	Ant. Height (cm)	Comments
1805.24								<b>Not in Restricted Band</b>
1805.24								<b>Done via Conducted</b>
2707.86	51.71	H	73.97	-22.26	Peak	305.75	159.19	
2707.86	31.71	H	53.97	-22.26	Avg	305.75	159.19	
3610.48	50.28	H	73.97	-23.69	Peak	314.00	159.25	
3610.48	30.28	H	53.97	-23.69	Avg	314.00	159.25	
4513.1	60.86	H	73.97	-13.11	Peak	11.00	126.71	
4513.1	40.86	H	53.97	-13.11	Avg	11.00	126.71	
5415.72	50.31	H	73.97	-23.66	Peak	0.00	175.01	
5415.72	30.31	H	53.97	-23.66	Avg	0.00	175.01	
6318.34								<b>Not in Restricted Band</b>
6318.34								<b>Done via Conducted</b>
7220.96								<b>Not in Restricted Band</b>
7220.96								<b>Done via Conducted</b>
8123.58	45.72	H	73.97	-28.25	Peak	284.25	175.13	
8123.58	25.72	H	53.97	-18.25	Avg	284.25	175.13	
9026.2	46.08	H	73.97	-27.89	Peak	55.50	191.19	
9026.2	26.08	H	53.97	-27.89	Avg	55.50	191.19	

**FCC 15.247**

Mesa Labs, Inc.  
 VPx 900 MHz Access Point  
 Model: CM-000250

Date: 08/01/2016  
 Lab: D  
 Tested By: Kyle Fujimoto

**L-COM Antenna**  
**Middle Channel - X-Axis**  
**Transmit Mode**

Freq. (MHz)	Level (dBuV)	Pol (v/h)	Limit	Margin	Peak / QP / Avg	Table Angle (deg)	Ant. Height (cm)	Comments
1830.24								Not in Restricted Band
1830.24								Done via Conducted
2745.36	53.30	V	73.97	-20.67	Peak	81.50	144.50	
2745.36	33.30	V	53.97	-20.67	Avg	81.50	144.50	
3660.48	55.56	V	73.97	-18.41	Peak	260.50	128.26	
3660.48	35.56	V	53.97	-18.41	Avg	260.50	128.26	
4575.6	66.28	V	73.97	-7.69	Peak	255.25	101.16	
4575.6	46.28	V	53.97	-7.69	Avg	255.25	101.16	
5490.72								Not in Restricted Band
5490.72								Done via Conducted
6405.84								Not in Restricted Band
6405.84								Done via Conducted
7320.96	53.46	V	73.97	-20.51	Peak	104.75	144.62	
7320.96	33.46	V	53.97	-20.51	Avg	104.75	144.62	
8236.08	51.39	V	73.97	-22.58	Peak	223.00	112.32	
8236.08	31.39	V	53.97	-22.58	Avg	223.00	112.32	
9151.2	49.87	V	73.97	-24.10	Peak	140.25	128.38	
9151.2	29.87	V	53.97	-24.10	Avg	140.25	128.38	

**FCC 15.247**

Mesa Labs, Inc.  
 VPx 900 MHz Access Point  
 Model: CM-000250

Date: 08/01/2016  
 Lab: D  
 Tested By: Kyle Fujimoto

**L-COM Antenna**  
**Middle Channel - Y-Axis**  
**Transmit Mode**

Freq. (MHz)	Level (dBuV)	Pol (v/h)	Limit	Margin	Peak / QP / Avg	Table Angle (deg)	Ant. Height (cm)	Comments
1830.24								Not in Restricted Band
1830.24								Done via Conducted
2745.36	50.56	V	73.97	-23.41	Peak	332.50	111.01	
2745.36	30.56	V	53.97	-23.41	Avg	332.50	111.01	
3660.48	46.55	V	73.97	-27.42	Peak	33.00	241.10	
3660.48	26.55	V	53.97	-27.42	Avg	33.00	241.10	
4575.6	55.74	V	73.97	-18.23	Peak	324.25	112.56	
4575.6	35.74	V	53.97	-18.23	Avg	324.25	112.56	
5490.72								Not in Restricted Band
5490.72								Done via Conducted
6405.84								Not in Restricted Band
6405.84								Done via Conducted
7320.96	45.97	V	73.97	-28.00	Peak	121.75	176.08	
7320.96	25.97	V	53.97	-28.00	Avg	121.75	176.08	
8236.08	48.10	V	73.97	-25.87	Peak	310.75	127.31	
8236.08	28.10	V	53.97	-25.87	Avg	310.75	127.31	
9151.2	47.15	V	73.97	-26.82	Peak	110.00	191.13	
9151.2	27.15	V	53.97	-26.82	Avg	110.00	191.13	



**FCC 15.247**

Mesa Labs, Inc.  
 VPx 900 MHz Access Point  
 Model: CM-000250

Date: 08/01/2016  
 Lab: D  
 Tested By: Kyle Fujimoto

**L-COM Antenna**  
**Middle Channel - Z-Axis**  
**Transmit Mode**

Freq. (MHz)	Level (dBuV)	Pol (v/h)	Limit	Margin	Peak / QP / Avg	Table Angle (deg)	Ant. Height (cm)	Comments
1830.24								Not in Restricted Band
1830.24								Done via Conducted
2745.36	44.66	V	73.97	-29.31	Peak	225.75	239.31	
2745.36	24.46	V	53.97	-29.51	Avg	225.75	239.31	
3660.48	55.31	V	73.97	-18.66	Peak	266.50	127.43	
3660.48	35.31	V	53.97	-18.66	Avg	266.50	127.43	
4575.6	64.67	V	73.97	-9.30	Peak	271.00	110.89	
4575.6	44.67	V	53.97	-9.30	Avg	271.00	110.89	
5490.72								Not in Restricted Band
5490.72								Done via Conducted
6405.84								Not in Restricted Band
6405.84								Done via Conducted
7320.96	53.49	V	73.97	-20.48	Peak	234.00	143.25	
7320.96	33.49	V	53.97	-20.48	Avg	234.00	143.25	
8236.08	50.22	V	73.97	-23.75	Peak	223.50	111.37	
8236.08	30.22	V	53.97	-23.75	Avg	223.50	111.37	
9151.2	51.16	V	73.97	-22.81	Peak	182.50	127.31	
9151.2	31.16	V	53.97	-22.81	Avg	182.50	127.31	

**FCC 15.247**

Mesa Labs, Inc.  
 VPx 900 MHz Access Point  
 Model: CM-000250

Date: 08/01/2016  
 Lab: D  
 Tested By: Kyle Fujimoto

**L-COM Antenna**  
**Middle Channel - X-Axis**  
**Transmit Mode**

Freq. (MHz)	Level (dBuV)	Pol (v/h)	Limit	Margin	Peak / QP / Avg	Table Angle (deg)	Ant. Height (cm)	Comments
1830.24								Not in Restricted Band
1830.24								Done via Conducted
2745.36	50.92	H	73.97	-23.05	Peak	122.50	112.62	
2745.36	30.92	H	53.97	-23.05	Avg	122.50	112.62	
3660.48	45.76	H	73.97	-28.21	Peak	259.50	112.56	
3660.48	25.76	H	53.97	-28.21	Avg	259.50	112.56	
4575.6	57.88	H	73.97	-16.09	Peak	40.00	111.49	
4575.6	37.88	H	53.97	-16.09	Avg	40.00	111.49	
5490.72								Not in Restricted Band
5490.72								Done via Conducted
6405.84								Not in Restricted Band
6405.84								Done via Conducted
7320.96	54.46	H	80.32	-25.86	Peak	324.50	142.95	
7320.96	34.46	H	80.29	-45.83	Avg	324.50	142.95	
8236.08	47.42	H	73.97	-26.55	Peak	249.75	111.25	
8236.08	27.42	H	53.97	-26.55	Avg	249.75	111.25	
9151.2	37.36	H	73.97	-36.61	Peak	191.25	111.25	
9151.2	17.36	H	53.97	-36.61	Avg	191.25	111.25	

**FCC 15.247**

Mesa Labs, Inc.  
 VPx 900 MHz Access Point  
 Model: CM-000250

Date: 08/01/2016  
 Lab: D  
 Tested By: Kyle Fujimoto

**L-COM Antenna**  
**Middle Channel - Y-Axis**  
**Transmit Mode**

Freq. (MHz)	Level (dBuV)	Pol (v/h)	Limit	Margin	Peak / QP / Avg	Table Angle (deg)	Ant. Height (cm)	Comments
1830.24								Not in Restricted Band
1830.24								Done via Conducted
2745.36	57.00	H	73.97	-16.97	Peak	291.25	223.43	
2745.36	37.00	H	53.97	-16.97	Avg	291.25	223.43	
3660.48	54.79	H	73.97	-19.18	Peak	33.00	110.65	
3660.48	34.79	H	53.97	-19.18	Avg	33.00	110.65	
4575.6	68.15	H	73.97	-5.82	Peak	268.25	126.95	
4575.6	48.15	H	53.97	-5.82	Avg	268.25	126.95	
5490.72								Not in Restricted Band
5490.72								Done via Conducted
6405.84								Not in Restricted Band
6405.84								Done via Conducted
7320.96	56.52	H	73.97	-17.45	Peak	23.50	175.07	
7320.96	36.52	H	53.97	-17.45	Avg	23.50	175.07	
8236.08	49.20	H	73.97	-24.77	Peak	340.75	127.19	
8236.08	29.20	H	53.97	-24.77	Avg	340.75	127.19	
9151.2	47.68	H	73.97	-26.29	Peak	20.50	191.37	
9151.2	27.68	H	53.97	-26.29	Avg	20.50	191.37	

**FCC 15.247**

Mesa Labs, Inc.  
 VPx 900 MHz Access Point  
 Model: CM-000250

Date: 08/01/2016  
 Lab: D  
 Tested By: Kyle Fujimoto

**L-COM Antenna**  
**Middle Channel - Z-Axis**  
**Transmit Mode**

Freq. (MHz)	Level (dBuV)	Pol (v/h)	Limit	Margin	Peak / QP / Avg	Table Angle (deg)	Ant. Height (cm)	Comments
1830.24								Not in Restricted Band
1830.24								Done via Conducted
2745.36	51.80	H	73.97	-22.17	Peak	121.25	191.31	
2745.36	31.80	H	53.97	-22.17	Avg	121.25	191.31	
3660.48	49.75	H	73.97	-24.22	Peak	124.00	143.07	
3660.48	29.75	H	53.97	-24.22	Avg	124.00	143.07	
4575.6	50.20	H	73.97	-23.77	Peak	275.00	143.25	
4575.6	30.20	H	53.97	-23.77	Avg	275.00	143.25	
5490.72								Not in Restricted Band
5490.72								Done via Conducted
6405.84								Not in Restricted Band
6405.84								Done via Conducted
7320.96	53.66	H	73.97	-20.31	Peak	128.25	111.37	
7320.96	33.66	H	53.97	-20.31	Avg	128.25	111.37	
8236.08	48.97	H	73.97	-25.00	Peak	244.00	126.77	
8236.08	28.97	H	53.97	-25.00	Avg	244.00	126.77	
9151.2	46.16	H	73.97	-27.81	Peak	232.25	127.37	
9151.2	26.16	H	53.97	-27.81	Avg	232.25	127.37	

**FCC 15.247**

Mesa Labs, Inc.  
 VPx 900 MHz Access Point  
 Model: CM-000250

Date: 08/01/2016  
 Lab: D  
 Tested By: Kyle Fujimoto

**L-COM Antenna**  
**High Channel - X-Axis**  
**Transmit Mode**

Freq. (MHz)	Level (dBuV)	Pol (v/h)	Limit	Margin	Peak / QP / Avg	Table Angle (deg)	Ant. Height (cm)	Comments
1855.24								Not in Restricted Band
1855.24								Done via Conducted
2782.86	58.03	V	73.97	-15.94	Peak	221.50	144.80	
2782.86	38.03	V	53.97	-15.94	Avg	221.50	144.80	
3710.48	57.22	V	73.97	-16.75	Peak	71.00	128.86	
3710.48	37.22	V	53.97	-16.75	Avg	71.00	128.86	
4638.1	65.65	V	73.97	-8.32	Peak	256.50	176.92	
4638.1	45.65	V	53.97	-8.32	Avg	256.50	176.92	
5565.72								Not in Restricted Band
5565.72								Done via Conducted
6493.34								Not in Restricted Band
6493.34								Done via Conducted
7420.96	46.83	V	73.97	-27.14	Peak	247.25	225.04	
7420.96	26.83	V	53.97	-27.14	Avg	247.25	225.04	
8348.58	55.85	V	73.97	-18.12	Peak	35.00	112.86	
8348.58	35.85	V	53.97	-18.12	Avg	35.00	112.86	
9276.2	46.37	V	73.97	-27.60	Peak	183.50	224.38	
9276.2	26.37	V	53.97	-27.60	Avg	183.50	224.38	

**FCC 15.247**

Mesa Labs, Inc.  
 VPx 900 MHz Access Point  
 Model: CM-000250

Date: 08/01/2016  
 Lab: D  
 Tested By: Kyle Fujimoto

**L-COM Antenna**  
**High Channel - Y-Axis**  
**Transmit Mode**

Freq. (MHz)	Level (dBuV)	Pol (v/h)	Limit	Margin	Peak / QP / Avg	Table Angle (deg)	Ant. Height (cm)	Comments
1855.24								Not in Restricted Band
1855.24								Done via Conducted
2782.86	59.88	V	73.97	-14.09	Peak	179.50	101.21	
2782.86	39.88	V	53.97	-14.09	Avg	179.50	101.21	
3710.48	53.16	V	73.97	-20.81	Peak	320.50	249.98	
3710.48	33.16	V	53.97	-20.81	Avg	320.50	249.98	
4638.1	59.88	V	73.97	-14.09	Peak	0.00	143.25	
4638.1	39.88	V	53.97	-14.09	Avg	0.00	143.25	
5565.72								Not in Restricted Band
5565.72								Done via Conducted
6493.34								Not in Restricted Band
6493.34								Done via Conducted
7420.96	52.32	V	73.97	-21.65	Peak	169.75	111.55	
7420.96	32.32	V	53.97	-21.65	Avg	169.75	111.55	
8348.58	55.83	V	73.97	-18.14	Peak	197.75	191.43	
8348.58	35.83	V	53.97	-18.14	Avg	197.75	191.43	
9276.2	45.66	V	73.97	-28.31	Peak	262.00	223.67	
9276.2	25.66	V	53.97	-28.31	Avg	262.00	223.67	

**FCC 15.247**

Mesa Labs, Inc.  
 VPx 900 MHz Access Point  
 Model: CM-000250

Date: 08/01/2016  
 Lab: D  
 Tested By: Kyle Fujimoto

**L-COM Antenna**  
**High Channel - Z-Axis**  
**Transmit Mode**

Freq. (MHz)	Level (dBuV)	Pol (v/h)	Limit	Margin	Peak / QP / Avg	Table Angle (deg)	Ant. Height (cm)	Comments
1855.24								<b>Not in Restricted Band</b>
1855.24								<b>Done via Conducted</b>
2782.86	50.75	V	73.97	-23.22	Peak	182.00	207.43	
2782.86	30.75	V	53.97	-23.22	Avg	182.00	207.43	
3710.48	42.82	V	73.97	-31.15	Peak	119.75	239.85	
3710.48	22.82	V	53.97	-31.15	Avg	119.75	239.85	
4638.1	53.91	V	73.97	-20.06	Peak	325.00	127.37	
4638.1	33.91	V	53.97	-20.06	Avg	325.00	127.37	
5565.72								<b>Not in Restricted Band</b>
5565.72								<b>Done via Conducted</b>
6493.34								<b>Not in Restricted Band</b>
6493.34								<b>Done via Conducted</b>
7420.96	43.67	V	73.97	-30.30	Peak	168.25	207.67	
7420.96	23.67	V	53.97	-30.30	Avg	168.25	207.67	
8348.58	45.62	V	73.97	-28.35	Peak	357.25	250.05	
8348.58	25.62	V	53.97	-28.35	Avg	357.25	250.05	
9276.2	45.30	V	73.97	-28.67	Peak	47.25	143.13	
9276.2	25.30	V	53.97	-28.67	Avg	47.25	143.13	

**FCC 15.247**

Mesa Labs, Inc.  
 VPx 900 MHz Access Point  
 Model: CM-000250

Date: 08/01/2016  
 Lab: D  
 Tested By: Kyle Fujimoto

**L-COM Antenna**  
**High Channel - X-Axis**  
**Transmit Mode**

Freq. (MHz)	Level (dBuV)	Pol (v/h)	Limit	Margin	Peak / QP / Avg	Table Angle (deg)	Ant. Height (cm)	Comments
1855.24								Not in Restricted Band
1855.24								Done via Conducted
2782.86	50.52	H	73.97	-23.45	Peak	121.00	223.91	
2782.86	30.52	H	53.97	-23.45	Avg	121.00	223.91	
3710.48	50.29	H	73.97	-23.68	Peak	278.00	111.25	
3710.48	30.29	H	53.97	-23.68	Avg	278.00	111.25	
4638.1	55.55	H	73.97	-18.42	Peak	257.50	223.61	
4638.1	35.55	H	53.97	-18.42	Avg	257.50	223.61	
5565.72								Not in Restricted Band
5565.72								Done via Conducted
6493.34								Not in Restricted Band
6493.34								Done via Conducted
7420.96	44.40	H	73.97	-29.57	Peak	308.25	159.73	
7420.96	24.40	H	53.97	-29.57	Avg	308.25	159.73	
8348.58	53.85	H	73.97	-20.12	Peak	54.00	111.67	
8348.58	33.85	H	53.97	-20.12	Avg	54.00	111.67	
9276.2	45.47	H	73.97	-28.50	Peak	240.50	143.37	
9276.2	25.47	H	53.97	-28.50	Avg	240.50	143.37	



**FCC 15.247**

Mesa Labs, Inc.  
 VPx 900 MHz Access Point  
 Model: CM-000250

Date: 08/01/2016  
 Lab: D  
 Tested By: Kyle Fujimoto

**L-COM Antenna**  
**High Channel - Y-Axis**  
**Transmit Mode**

Freq. (MHz)	Level (dBuV)	Pol (v/h)	Limit	Margin	Peak / QP / Avg	Table Angle (deg)	Ant. Height (cm)	Comments
1855.24								Not in Restricted Band
1855.24								Done via Conducted
2782.86	53.03	H	73.97	-20.94	Peak	213.50	111.43	
2782.86	33.03	H	53.97	-20.94	Avg	213.50	111.43	
3710.48	50.85	H	73.97	-23.12	Peak	225.25	191.37	
3710.48	30.85	H	53.97	-23.12	Avg	225.25	191.37	
4638.1	53.08	H	73.97	-20.89	Peak	163.25	111.07	
4638.1	33.08	H	53.97	-20.89	Avg	163.25	111.07	
5565.72								Not in Restricted Band
5565.72								Done via Conducted
6493.34								Not in Restricted Band
6493.34								Done via Conducted
7420.96	44.42	H	73.97	-29.55	Peak	116.50	111.13	
7420.96	24.42	H	53.97	-29.55	Avg	116.50	111.13	
8348.58	49.37	H	73.97	-24.60	Peak	219.00	175.19	
8348.58	29.37	H	53.97	-24.60	Avg	219.00	175.19	
9276.2	46.06	H	73.97	-27.91	Peak	9.00	239.85	
9276.2	26.06	H	53.97	-27.91	Avg	9.00	239.85	

**FCC 15.247**

Mesa Labs, Inc.  
 VPx 900 MHz Access Point  
 Model: CM-000250

Date: 08/01/2016  
 Lab: D  
 Tested By: Kyle Fujimoto

**L-COM Antenna**  
**High Channel - Z-Axis**  
**Transmit Mode**

Freq. (MHz)	Level (dBuV)	Pol (v/h)	Limit	Margin	Peak / QP / Avg	Table Angle (deg)	Ant. Height (cm)	Comments
1855.24								Not in Restricted Band
1855.24								Done via Conducted
2782.86	61.16	H	73.97	-12.81	Peak	226.00	158.95	
2782.86	41.16	H	53.97	-12.81	Avg	226.00	158.95	
3710.48	57.42	H	73.97	-16.55	Peak	226.50	159.43	
3710.48	37.42	H	53.97	-16.55	Avg	226.50	159.43	
4638.1	68.39	H	73.97	-5.58	Peak	80.50	223.61	
4638.1	48.39	H	53.97	-5.58	Avg	80.50	223.61	
5565.72								Not in Restricted Band
5565.72								Done via Conducted
6493.34								Not in Restricted Band
6493.34								Done via Conducted
7420.96	54.36	H	73.97	-19.61	Peak	156.25	175.37	
7420.96	34.36	H	53.97	-19.61	Avg	156.25	175.37	
8348.58	56.56	H	73.97	-17.41	Peak	103.00	111.37	
8348.58	36.56	H	53.97	-17.41	Avg	103.00	111.37	
9276.2	46.06	H	73.97	-27.91	Peak	222.00	127.19	
9276.2	26.06	H	53.97	-27.91	Avg	222.00	127.19	





**FCC 15.247**

Mesa Labs, Inc.  
 VPx 900 MHz Access Point  
 Model: CM-000250

Date: 08/01/2016  
 Lab: D  
 Tested By: Kyle Fujimoto

**Pulse Antenna**

**Low Channel - X-Axis**

**Transmit Mode**

Freq. (MHz)	Level (dBuV)	Pol (v/h)	Limit	Margin	Peak / QP / Avg	Table Angle (deg)	Ant. Height (cm)	Comments
1805.24								Not in Restricted Band
1805.24								Done via Conducted
2707.86	51.64	V	73.97	-22.33	Peak	224.50	111.31	
2707.86	31.64	V	53.97	-22.33	Avg	224.50	111.31	
3610.48	47.54	V	73.97	-26.43	Peak	1.50	127.31	
3610.48	27.54	V	53.97	-26.43	Avg	1.50	127.31	
4513.1	56.72	V	73.97	-17.25	Peak	171.75	111.13	
4513.1	36.72	V	53.97	-17.25	Avg	171.75	111.13	
5415.72	46.30	V	73.97	-27.67	Peak	238.75	111.49	
5415.72	26.30	V	53.97	-27.67	Avg	238.75	111.49	
6318.34								Not in Restricted Band
6318.34								Done via Conducted
7220.96								Not in Restricted Band
7220.96								Done via Conducted
8123.58	56.44	V	73.97	-17.53	Peak	198.50	111.55	
8123.58	36.44	V	53.97	-17.53	Avg	198.50	111.55	
9026.2	48.75	V	73.97	-25.22	Peak	178.75	159.37	
9026.2	28.75	V	53.97	-25.22	Avg	178.75	159.37	

**FCC 15.247**

Mesa Labs, Inc.  
 VPx 900 MHz Access Point  
 Model: CM-000250

Date: 08/01/2016  
 Lab: D  
 Tested By: Kyle Fujimoto

**Pulse Antenna**  
**Low Channel - Y-Axis**  
**Transmit Mode**

Freq. (MHz)	Level (dBuV)	Pol (v/h)	Limit	Margin	Peak / QP / Avg	Table Angle (deg)	Ant. Height (cm)	Comments
1805.24								<b>Not in Restricted Band</b>
1805.24								<b>Done via Conducted</b>
2707.86	45.14	V	73.97	-28.83	Peak	167.75	249.94	
2707.86	25.14	V	53.97	-28.83	Avg	167.75	249.94	
3610.48	39.63	V	73.97	-34.34	Peak	132.75	159.55	
3610.48	19.63	V	53.97	-34.34	Avg	132.75	159.55	
4513.1	58.00	V	73.97	-15.97	Peak	98.50	127.01	
4513.1	38.00	V	53.97	-15.97	Avg	98.50	127.01	
5415.72	46.65	V	73.97	-27.32	Peak	95.75	223.61	
5415.72	26.65	V	53.97	-27.32	Avg	95.75	223.61	
6318.34								<b>Not in Restricted Band</b>
6318.34								<b>Done via Conducted</b>
7220.96								<b>Not in Restricted Band</b>
7220.96								<b>Done via Conducted</b>
8123.58	51.50	V	73.97	-22.47	Peak	98.50	159.25	
8123.58	31.50	V	53.97	-22.47	Avg	98.50	159.25	
9026.2	64.61	V	73.97	-9.36	Peak	81.25	238.95	
9026.2	44.61	V	53.97	-9.36	Avg	81.25	238.95	

**FCC 15.247**

Mesa Labs, Inc.  
 VPx 900 MHz Access Point  
 Model: CM-000250

Date: 08/01/2016  
 Lab: D  
 Tested By: Kyle Fujimoto

**Pulse Antenna**  
**Low Channel - Z-Axis**  
**Transmit Mode**

Freq. (MHz)	Level (dBuV)	Pol (v/h)	Limit	Margin	Peak / QP / Avg	Table Angle (deg)	Ant. Height (cm)	Comments
1805.24								Not in Restricted Band
1805.24								Done via Conducted
2707.86	55.63	V	73.97	-18.34	Peak	268.00	159.13	
2707.86	35.63	V	53.97	-18.34	Avg	268.00	159.13	
3610.48	48.80	V	73.97	-25.17	Peak	252.75	127.07	
3610.48	28.80	V	53.97	-25.17	Avg	252.75	127.07	
4513.1	63.90	V	73.97	-10.07	Peak	231.00	128.26	
4513.1	43.90	V	53.97	-10.07	Avg	231.00	128.26	
5415.72	46.22	V	73.97	-27.75	Peak	264.75	127.25	
5415.72	26.22	V	53.97	-27.75	Avg	264.75	127.25	
6318.34								Not in Restricted Band
6318.34								Done via Conducted
7220.96								Not in Restricted Band
7220.96								Done via Conducted
8123.58	53.64	V	73.97	-20.33	Peak	218.00	175.19	
8123.58	33.64	V	53.97	-20.33	Avg	218.00	175.19	
9026.2	48.54	V	73.97	-25.43	Peak	142.00	126.95	
9026.2	28.54	V	53.97	-25.43	Avg	142.00	126.95	

**FCC 15.247**

Mesa Labs, Inc.  
 VPx 900 MHz Access Point  
 Model: CM-000250

Date: 08/01/2016  
 Lab: D  
 Tested By: Kyle Fujimoto

**Pulse Antenna**  
**Low Channel - X-Axis**  
**Transmit Mode**

Freq. (MHz)	Level (dBuV)	Pol (v/h)	Limit	Margin	Peak / QP / Avg	Table Angle (deg)	Ant. Height (cm)	Comments
1805.24								Not in Restricted Band
1805.24								Done via Conducted
2707.86	51.10	H	73.97	-22.87	Peak	92.75	160.92	
2707.86	31.10	H	53.97	-22.87	Avg	92.75	160.92	
3610.48	42.44	H	73.97	-31.53	Peak	355.50	111.31	
3610.48	22.44	H	53.97	-31.53	Avg	355.50	111.31	
4513.1	57.44	H	73.97	-16.53	Peak	263.25	111.61	
4513.1	37.44	H	53.97	-16.53	Avg	263.25	111.61	
5415.72	42.44	H	73.97	-31.53	Peak	160.25	239.61	
5415.72	22.44	H	53.97	-31.53	Avg	160.25	239.61	
6318.34								Not in Restricted Band
6318.34								Done via Conducted
7220.96								Not in Restricted Band
7220.96								Done via Conducted
8123.58	53.91	H	73.97	-20.06	Peak	95.50	127.31	
8123.58	33.91	H	53.97	-20.06	Avg	95.50	127.31	
9026.2	48.51	H	73.97	-25.46	Peak	141.25	127.37	
9026.2	28.51	H	53.97	-25.46	Avg	141.25	127.37	



**FCC 15.247**

Mesa Labs, Inc.  
 VPx 900 MHz Access Point  
 Model: CM-000250

Date: 08/01/2016  
 Lab: D  
 Tested By: Kyle Fujimoto

**Pulse Antenna**  
**Low Channel - Y-Axis**  
**Transmit Mode**

Freq. (MHz)	Level (dBuV)	Pol (v/h)	Limit	Margin	Peak / QP / Avg	Table Angle (deg)	Ant. Height (cm)	Comments
1805.24								Not in Restricted Band
1805.24								Done via Conducted
2707.86	51.44	H	73.97	-22.53	Peak	258.25	111.25	
2707.86	31.44	H	53.97	-22.53	Avg	258.25	111.25	
3610.48	51.18	H	73.97	-22.79	Peak	26.75	127.31	
3610.48	31.18	H	53.97	-22.79	Avg	26.75	127.31	
4513.1	56.02	H	73.97	-17.95	Peak	295.75	111.19	
4513.1	36.02	H	53.97	-17.95	Avg	295.75	111.19	
5415.72	53.99	H	73.97	-19.98	Peak	179.75	159.31	
5415.72	33.99	H	53.97	-19.98	Avg	179.75	159.31	
6318.34								Not in Restricted Band
6318.34								Done via Conducted
7220.96								Not in Restricted Band
7220.96								Done via Conducted
8123.58	57.31	H	73.97	-16.66	Peak	122.00	127.13	
8123.58	37.31	H	53.97	-16.66	Avg	122.00	127.13	
9026.2	52.00	H	73.97	-21.97	Peak	105.25	127.19	
9026.2	32.00	H	53.97	-21.97	Avg	105.25	127.19	

**FCC 15.247**

Mesa Labs, Inc.  
 VPx 900 MHz Access Point  
 Model: CM-000250

Date: 08/01/2016  
 Lab: D  
 Tested By: Kyle Fujimoto

**Pulse Antenna**  
**Low Channel - Z-Axis**  
**Transmit Mode**

Freq. (MHz)	Level (dBuV)	Pol (v/h)	Limit	Margin	Peak / QP / Avg	Table Angle (deg)	Ant. Height (cm)	Comments
1805.24								Not in Restricted Band
1805.24								Done via Conducted
2707.86	55.57	H	73.97	-18.40	Peak	258.50	158.53	
2707.86	35.57	H	53.97	-18.40	Avg	258.50	158.53	
3610.48	43.94	H	73.97	-30.03	Peak	26.25	175.31	
3610.48	23.94	H	53.97	-30.03	Avg	26.25	175.31	
4513.1	55.92	H	73.97	-18.05	Peak	288.25	111.31	
4513.1	35.92	H	53.97	-18.05	Avg	288.25	111.31	
5415.72	42.52	H	73.97	-31.45	Peak	152.50	111.25	
5415.72	22.52	H	53.97	-31.45	Avg	152.50	111.25	
6318.34								Not in Restricted Band
6318.34								Done via Conducted
7220.96								Not in Restricted Band
7220.96								Done via Conducted
8123.58	45.84	H	73.97	-28.13	Peak	236.50	249.17	
8123.58	25.84	H	53.97	-28.13	Avg	236.50	249.17	
9026.2	44.65	H	73.97	-29.32	Peak	147.75	239.43	
9026.2	24.65	H	53.97	-29.32	Avg	147.75	239.43	

**FCC 15.247**

Mesa Labs, Inc.  
 VPx 900 MHz Access Point  
 Model: CM-000250

Date: 08/01/2016  
 Lab: D  
 Tested By: Kyle Fujimoto

**Pulse Antenna**  
**Middle Channel - X-Axis**  
**Transmit Mode**

Freq. (MHz)	Level (dBuV)	Pol (v/h)	Limit	Margin	Peak / QP / Avg	Table Angle (deg)	Ant. Height (cm)	Comments
1830.24								Not in Restricted Band
1830.24								Done via Conducted
2745.36	45.08	V	73.97	-28.89	Peak	130.75	207.01	
2745.36	25.08	V	53.97	-28.89	Avg	130.75	207.01	
3660.48	46.88	V	73.97	-27.09	Peak	106.00	127.25	
3660.48	26.88	V	53.97	-27.09	Avg	106.00	127.25	
4575.6	55.84	V	73.97	-18.13	Peak	90.00	110.95	
4575.6	35.84	V	53.97	-18.13	Avg	90.00	110.95	
5490.72								Not in Restricted Band
5490.72								Done via Conducted
6405.84								Not in Restricted Band
6405.84								Done via Conducted
7320.96	53.44	V	73.97	-20.53	Peak	324.25	111.37	
7320.96	33.44	V	53.97	-20.53	Avg	324.25	111.37	
8236.08	46.17	V	73.97	-27.80	Peak	241.50	239.43	
8236.08	26.17	V	53.97	-27.80	Avg	241.50	239.43	
9151.2	45.03	V	73.97	-28.94	Peak	31.75	127.31	
9151.2	25.03	V	53.97	-28.94	Avg	31.75	127.31	

**FCC 15.247**

Mesa Labs, Inc.  
 VPx 900 MHz Access Point  
 Model: CM-000250

Date: 08/01/2016  
 Lab: D  
 Tested By: Kyle Fujimoto

**Pulse Antenna**  
**Middle Channel - Y-Axis**  
**Transmit Mode**

Freq. (MHz)	Level (dBuV)	Pol (v/h)	Limit	Margin	Peak / QP / Avg	Table Angle (deg)	Ant. Height (cm)	Comments
1830.24								Not in Restricted Band
1830.24								Done via Conducted
2745.36	60.15	V	73.97	-13.82	Peak	37.75	161.16	
2745.36	40.15	V	53.97	-13.82	Avg	37.75	161.16	
3660.48	55.99	V	73.97	-17.98	Peak	38.75	160.56	
3660.48	35.99	V	53.97	-17.98	Avg	38.75	160.56	
4575.6	65.97	V	73.97	-8.00	Peak	51.00	128.26	
4575.6	45.97	V	53.97	-8.00	Avg	51.00	128.26	
5490.72								Not in Restricted Band
5490.72								Done via Conducted
6405.84								Not in Restricted Band
6405.84								Done via Conducted
7320.96	57.22	V	73.97	-16.75	Peak	332.00	128.56	
7320.96	37.22	V	53.97	-16.75	Avg	332.00	128.56	
8236.08	49.75	V	73.97	-24.22	Peak	263.00	101.18	
8236.08	29.75	V	53.97	-24.22	Avg	263.00	101.18	
9151.2	46.27	V	73.97	-27.70	Peak	253.00	208.50	
9151.2	26.27	V	53.97	-27.70	Avg	253.00	208.50	

**FCC 15.247**

Mesa Labs, Inc.  
 VPx 900 MHz Access Point  
 Model: CM-000250

Date: 08/01/2016  
 Lab: D  
 Tested By: Kyle Fujimoto

**Pulse Antenna**  
**Middle Channel - Z-Axis**  
**Transmit Mode**

Freq. (MHz)	Level (dBuV)	Pol (v/h)	Limit	Margin	Peak / QP / Avg	Table Angle (deg)	Ant. Height (cm)	Comments
1830.24								Not in Restricted Band
1830.24								Done via Conducted
2745.36	54.02	V	73.97	-19.95	Peak	12.75	128.62	
2745.36	34.02	V	53.97	-19.95	Avg	12.75	128.62	
3660.48	49.21	V	73.97	-24.76	Peak	85.50	207.25	
3660.48	29.21	V	53.97	-24.76	Avg	85.50	207.25	
4575.6	54.64	V	73.97	-19.33	Peak	37.25	175.43	
4575.6	34.64	V	53.97	-19.33	Avg	37.25	175.43	
5490.72								Not in Restricted Band
5490.72								Done via Conducted
6405.84								Not in Restricted Band
6405.84								Done via Conducted
7320.96	44.77	V	73.97	-29.20	Peak	77.25	127.07	
7320.96	24.77	V	53.97	-29.20	Avg	77.25	127.07	
8236.08	49.70	V	73.97	-24.27	Peak	83.00	101.01	
8236.08	29.70	V	53.97	-24.27	Avg	83.00	101.01	
9151.2	50.45	V	73.97	-23.52	Peak	84.00	174.83	
9151.2	30.45	V	53.97	-23.52	Avg	84.00	174.83	

**FCC 15.247**

Mesa Labs, Inc.  
 VPx 900 MHz Access Point  
 Model: CM-000250

Date: 08/01/2016  
 Lab: D  
 Tested By: Kyle Fujimoto

**Pulse Antenna**  
**Middle Channel - X-Axis**  
**Transmit Mode**

Freq. (MHz)	Level (dBuV)	Pol (v/h)	Limit	Margin	Peak / QP / Avg	Table Angle (deg)	Ant. Height (cm)	Comments
1830.24								Not in Restricted Band
1830.24								Done via Conducted
2745.36	52.89	H	73.97	-21.08	Peak	238.00	175.19	
2745.36	32.89	H	53.97	-21.08	Avg	238.00	175.19	
3660.48	54.54	H	73.97	-19.43	Peak	268.25	111.31	
3660.48	34.54	H	53.97	-19.43	Avg	268.25	111.31	
4575.6	65.31	H	73.97	-8.66	Peak	268.00	127.37	
4575.6	45.31	H	53.97	-8.66	Avg	268.00	127.37	
5490.72								Not in Restricted Band
5490.72								Done via Conducted
6405.84								Not in Restricted Band
6405.84								Done via Conducted
7320.96	50.39	H	73.97	-23.58	Peak	104.75	158.89	
7320.96	30.39	H	53.97	-23.58	Avg	104.75	158.89	
8236.08	48.60	H	73.97	-25.37	Peak	144.75	101.25	
8236.08	28.60	H	53.97	-25.37	Avg	144.75	101.25	
9151.2	50.01	H	73.97	-23.96	Peak	182.00	127.13	
9151.2	30.01	H	53.97	-23.96	Avg	182.00	127.13	

**FCC 15.247**

Mesa Labs, Inc.  
 VPx 900 MHz Access Point  
 Model: CM-000250

Date: 08/01/2016  
 Lab: D  
 Tested By: Kyle Fujimoto

**Pulse Antenna  
 Middle Channel - Y-Axis  
 Transmit Mode**

Freq. (MHz)	Level (dBuV)	Pol (v/h)	Limit	Margin	Peak / QP / Avg	Table Angle (deg)	Ant. Height (cm)	Comments
1830.24								Not in Restricted Band
1830.24								Done via Conducted
2745.36	48.17	H	73.97	-25.80	Peak	292.25	150.07	
2745.36	28.17	H	53.97	-25.80	Avg	292.25	150.07	
3660.48	40.02	H	73.97	-33.95	Peak	126.00	191.19	
3660.48	20.02	H	53.97	-33.95	Avg	126.00	191.19	
4575.6	57.35	H	73.97	-16.62	Peak	258.00	159.13	
4575.6	37.35	H	53.97	-16.62	Avg	258.00	159.13	
5490.72								Not in Restricted Band
5490.72								Done via Conducted
6405.84								Not in Restricted Band
6405.84								Done via Conducted
7320.96	44.84	H	73.97	-29.13	Peak	7.00	175.01	
7320.96	24.84	H	53.97	-29.13	Avg	7.00	175.01	
8236.08	45.62	H	73.97	-28.35	Peak	297.50	175.31	
8236.08	25.62	H	53.97	-28.35	Avg	297.50	175.31	
9151.2	45.45	H	73.97	-28.52	Peak	176.75	207.25	
9151.2	25.45	H	53.97	-28.52	Avg	176.75	207.25	



**FCC 15.247**

Mesa Labs, Inc.  
 VPx 900 MHz Access Point  
 Model: CM-000250

Date: 08/01/2016  
 Lab: D  
 Tested By: Kyle Fujimoto

**Pulse Antenna**  
**Middle Channel - Z-Axis**  
**Transmit Mode**

Freq. (MHz)	Level (dBuV)	Pol (v/h)	Limit	Margin	Peak / QP / Avg	Table Angle (deg)	Ant. Height (cm)	Comments
1830.24								Not in Restricted Band
1830.24								Done via Conducted
2745.36	55.93	H	73.97	-18.04	Peak	359.25	143.01	
2745.36	35.93	H	53.97	-18.04	Avg	359.25	143.01	
3660.48	51.08	H	73.97	-22.89	Peak	22.00	159.01	
3660.48	31.08	H	53.97	-22.89	Avg	22.00	159.01	
4575.6	60.49	H	73.97	-13.48	Peak	137.75	127.25	
4575.6	40.49	H	53.97	-13.48	Avg	137.75	127.25	
5490.72								Not in Restricted Band
5490.72								Done via Conducted
6405.84								Not in Restricted Band
6405.84								Done via Conducted
7320.96	58.67	H	73.97	-15.30	Peak	336.00	251.85	
7320.96	38.67	H	53.97	-15.30	Avg	336.00	251.85	
8236.08	46.94	H	73.97	-27.03	Peak	308.75	207.55	
8236.08	26.94	H	53.97	-27.03	Avg	308.75	207.55	
9151.2	45.64	H	73.97	-28.33	Peak	99.25	175.31	
9151.2	25.64	H	53.97	-28.33	Avg	99.25	175.31	

**FCC 15.247**

Mesa Labs, Inc.  
 VPx 900 MHz Access Point  
 Model: CM-000250

Date: 08/01/2016  
 Lab: D  
 Tested By: Kyle Fujimoto

**Pulse Antenna**  
**High Channel - X-Axis**  
**Transmit Mode**

Freq. (MHz)	Level (dBuV)	Pol (v/h)	Limit	Margin	Peak / QP / Avg	Table Angle (deg)	Ant. Height (cm)	Comments
1855.24								Not in Restricted Band
1855.24								Done via Conducted
2782.86	42.16	V	73.97	-31.81	Peak	34.75	191.43	
2782.86	22.16	V	53.97	-31.81	Avg	34.75	191.43	
3710.48	51.43	V	73.97	-22.54	Peak	56.50	143.31	
3710.48	31.43	V	53.97	-22.54	Avg	56.50	143.31	
4638.1	66.47	V	73.97	-7.50	Peak	259.00	111.49	
4638.1	46.47	V	53.97	-7.50	Avg	259.00	111.49	
5565.72								Not in Restricted Band
5565.72								Done via Conducted
6493.34								Not in Restricted Band
6493.34								Done via Conducted
7420.96	50.95	V	73.97	-23.02	Peak	49.00	127.07	
7420.96	30.95	V	53.97	-23.02	Avg	49.00	127.07	
8348.58	55.29	V	73.97	-18.68	Peak	312.00	111.37	
8348.58	35.29	V	53.97	-18.68	Avg	312.00	111.37	
9276.2	45.15	V	73.97	-28.82	Peak	7.50	127.37	
9276.2	25.15	V	53.97	-28.82	Avg	7.50	127.37	

**FCC 15.247**

Mesa Labs, Inc.  
 VPx 900 MHz Access Point  
 Model: CM-000250

Date: 08/01/2016  
 Lab: D  
 Tested By: Kyle Fujimoto

**Pulse Antenna**  
**High Channel - Y-Axis**  
**Transmit Mode**

Freq. (MHz)	Level (dBuV)	Pol (v/h)	Limit	Margin	Peak / QP / Avg	Table Angle (deg)	Ant. Height (cm)	Comments
1855.24								Not in Restricted Band
1855.24								Done via Conducted
2782.86	53.57	V	73.97	-20.40	Peak	96.25	127.01	
2782.86	33.57	V	53.97	-20.40	Avg	96.25	127.01	
3710.48	46.98	V	73.97	-26.99	Peak	359.25	111.43	
3710.48	26.98	V	53.97	-26.99	Avg	359.25	111.43	
4638.1	55.81	V	73.97	-18.16	Peak	294.75	111.55	
4638.1	35.81	V	53.97	-18.16	Avg	294.75	111.55	
5565.72								Not in Restricted Band
5565.72								Done via Conducted
6493.34								Not in Restricted Band
6493.34								Done via Conducted
7420.96	47.84	V	73.97	-26.13	Peak	160.00	111.37	
7420.96	27.84	V	53.97	-26.13	Avg	160.00	111.37	
8348.58	49.52	V	73.97	-24.45	Peak	129.25	223.25	
8348.58	29.52	V	53.97	-24.45	Avg	129.25	223.25	
9276.2	45.75	V	73.97	-28.22	Peak	272.75	111.13	
9276.2	25.75	V	53.97	-28.22	Avg	272.75	111.13	

**FCC 15.247**

Mesa Labs, Inc.  
 VPx 900 MHz Access Point  
 Model: CM-000250

Date: 08/01/2016  
 Lab: D  
 Tested By: Kyle Fujimoto

**Pulse Antenna**  
**High Channel - Z-Axis**  
**Transmit Mode**

Freq. (MHz)	Level (dBuV)	Pol (v/h)	Limit	Margin	Peak / QP / Avg	Table Angle (deg)	Ant. Height (cm)	Comments
1855.24								Not in Restricted Band
1855.24								Done via Conducted
2782.86	53.65	V	73.97	-20.32	Peak	299.75	143.13	
2782.86	33.65	V	53.97	-20.32	Avg	299.75	143.13	
3710.48	45.04	V	73.97	-28.93	Peak	292.00	207.25	
3710.48	25.04	V	53.97	-28.93	Avg	292.00	207.25	
4638.1	57.18	V	73.97	-16.79	Peak	221.50	159.07	
4638.1	37.18	V	53.97	-16.79	Avg	221.50	159.07	
5565.72								Not in Restricted Band
5565.72								Done via Conducted
6493.34								Not in Restricted Band
6493.34								Done via Conducted
7420.96	44.22	V	73.97	-29.75	Peak	120.50	143.07	
7420.96	24.22	V	53.97	-29.75	Avg	120.50	143.07	
8348.58	52.55	V	73.97	-21.42	Peak	350.00	111.43	
8348.58	32.55	V	53.97	-21.42	Avg	350.00	111.43	
9276.2	45.84	V	73.97	-28.13	Peak	248.00	224.38	
9276.2	25.84	V	53.97	-28.13	Avg	248.00	224.38	

**FCC 15.247**

Mesa Labs, Inc.  
 VPx 900 MHz Access Point  
 Model: CM-000250

Date: 08/01/2016  
 Lab: D  
 Tested By: Kyle Fujimoto

**Pulse Antenna**  
**High Channel - X-Axis**  
**Transmit Mode**

Freq. (MHz)	Level (dBuV)	Pol (v/h)	Limit	Margin	Peak / QP / Avg	Table Angle (deg)	Ant. Height (cm)	Comments
1855.24								Not in Restricted Band
1855.24								Done via Conducted
2782.86	52.75	H	73.97	-21.22	Peak	300.00	160.74	
2782.86	32.75	H	53.97	-21.22	Avg	300.00	160.74	
3710.48	45.29	H	73.97	-28.68	Peak	284.25	207.61	
3710.48	25.29	H	53.97	-28.68	Avg	284.25	207.61	
4638.1	57.65	H	73.97	-16.32	Peak	220.25	127.31	
4638.1	37.65	H	53.97	-16.32	Avg	220.25	127.31	
5565.72								Not in Restricted Band
5565.72								Done via Conducted
6493.34								Not in Restricted Band
6493.34								Done via Conducted
7420.96	44.47	H	73.97	-29.50	Peak	138.25	111.25	
7420.96	24.47	H	53.97	-29.50	Avg	138.25	111.25	
8348.58	45.52	H	73.97	-28.45	Peak	137.25	191.31	
8348.58	25.52	H	53.97	-28.45	Avg	137.25	191.31	
9276.2	45.47	H	73.97	-28.50	Peak	313.50	191.73	
9276.2	25.47	H	53.97	-28.50	Avg	313.50	191.73	

**FCC 15.247**

Mesa Labs, Inc.  
 VPx 900 MHz Access Point  
 Model: CM-000250

Date: 08/01/2016  
 Lab: D  
 Tested By: Kyle Fujimoto

**Pulse Antenna**  
**High Channel - Y-Axis**  
**Transmit Mode**

Freq. (MHz)	Level (dBuV)	Pol (v/h)	Limit	Margin	Peak / QP / Avg	Table Angle (deg)	Ant. Height (cm)	Comments
1855.24								Not in Restricted Band
1855.24								Done via Conducted
2782.86	62.40	H	73.97	-11.57	Peak	215.50	174.95	
2782.86	42.40	H	53.97	-11.57	Avg	215.50	174.95	
3710.48	52.30	H	73.97	-21.67	Peak	212.25	159.31	
3710.48	32.30	H	53.97	-21.67	Avg	212.25	159.31	
4638.1	69.49	H	73.97	-4.48	Peak	220.75	143.19	
4638.1	49.49	H	53.97	-4.48	Avg	220.75	143.19	
5565.72								Not in Restricted Band
5565.72								Done via Conducted
6493.34								Not in Restricted Band
6493.34								Done via Conducted
7420.96	56.06	H	73.97	-17.91	Peak	162.00	127.13	
7420.96	36.06	H	53.97	-17.91	Avg	162.00	127.13	
8348.58	55.03	H	73.97	-18.94	Peak	126.50	111.55	
8348.58	33.03	H	53.97	-20.94	Avg	126.50	111.55	
9276.2	45.47	H	73.97	-28.50	Peak	121.50	177.10	
9276.2	25.47	H	53.97	-28.50	Avg	121.50	177.10	

**FCC 15.247**

Mesa Labs, Inc.  
 VPx 900 MHz Access Point  
 Model: CM-000250

Date: 08/01/2016  
 Lab: D  
 Tested By: Kyle Fujimoto

**Pulse Antenna**  
**High Channel - Z-Axis**  
**Transmit Mode**

Freq. (MHz)	Level (dBuV)	Pol (v/h)	Limit	Margin	Peak / QP / Avg	Table Angle (deg)	Ant. Height (cm)	Comments
1855.24								Not in Restricted Band
1855.24								Done via Conducted
2782.86	58.58	H	73.97	-15.39	Peak	33.75	142.95	
2782.86	38.58	H	53.97	-15.39	Avg	33.75	142.95	
3710.48	52.08	H	73.97	-21.89	Peak	56.50	126.95	
3710.48	32.08	H	53.97	-21.89	Avg	56.50	126.95	
4638.1	67.61	H	73.97	-6.36	Peak	258.00	159.43	
4638.1	47.61	H	53.97	-6.36	Avg	258.00	159.43	
5565.72								Not in Restricted Band
5565.72								Done via Conducted
6493.34								Not in Restricted Band
6493.34								Done via Conducted
7420.96	50.67	H	73.97	-23.30	Peak	257.00	127.07	
7420.96	30.67	H	53.97	-23.30	Avg	257.00	127.07	
8348.58	56.17	H	73.97	-17.80	Peak	28.25	110.89	
8348.58	36.17	H	53.97	-17.80	Avg	28.25	110.89	
9276.2	47.63	H	73.97	-26.34	Peak	110.50	127.13	
9276.2	27.63	H	53.97	-26.34	Avg	110.50	127.13	



**FCC 15.247**

Mesa Labs, Inc.  
 VPx 900 MHz Access Point  
 Model: CM-000250  
**Pulse Antenna**

Date: 08/01/2016  
 Lab: D  
 Tested By: Kyle Fujimoto

**Non Harmonic Emissions from the Tx - 10 kHz to 30 MHz and 1 GHz to 9.3 GHz**  
**Digital Portion from the EUT - 10 kHz to 30 MHz and 1 GHz to 9.3 GHz**

Freq. (MHz)	Level (dBuV)	Pol (v/h)	Limit	Margin	Peak / QP / Avg	Ant. Height (m)	Table Angle (deg)	Comments
								No Emissions Detected
								from the Non Harmonic Emissions
								from the Tx
								10 kHz to 30 MHz
								No Emissions Detected
								from the Non Harmonic Emissions
								from the Tx
								1 GHz to 9.3 GHz
								No Emissions Detected
								from the Digital Portion
								of the EUT
								10 kHz to 30 MHz
								No Emissions Detected
								from the Digital Portion
								of the EUT
								1 GHz to 9.3 GHz
								Tested in both Horizontal and
								Vertical Polarizations

**FCC Class B and RSS-GEN**

Mesa Labs, Inc.  
VPx 900 MHz Access Point  
Model: CM-000250

Date: 08/01/2016  
Lab: D  
Tested By: Kyle Fujimoto

**Pulse Antenna**

**Receiver Portion - 10 kHz to 30 MHz and 1 GHz to 9.3 GHz**

Freq. (MHz)	Level (dBuV)	Pol (v/h)	Limit	Margin	Peak / QP / Avg	Ant. Height (m)	Table Angle (deg)	Comments
								No Emissions Detected
								in Receiver Mode
								10 kHz to 30 MHz
								No Emissions Detected
								in Receiver Mode
								1 GHz to 9.3 GHz
								No Emissions Detected
								in Receiver Mode
								30 MHz to 1 GHz
								Tested in both Horizontal and Vertical Polarizations

Title: Pre-Scan - FCC Class B  
 File: 4 - Agilent - Pre-Scan - PULSE - FCC Class B.set  
 Operator: Kyle Fujimoto  
 EUT Type: VPx Access Point  
 EUT Condition: The EUT is continuously transmitting at 902.62 MHz - X-Axis Worst Case Comments: Company: Mesa Labs, Inc.  
 Model: CM-000250  
 With PULSE Antenna  
 Note: The frequencies not marked are all outside the restricted bands of FCC 15.205 and thus not subject to FCC Class B Limits

8/1/2016 2:02:15 PM  
 Sequence: Preliminary Scan

FCC Class B and FCC 15.247

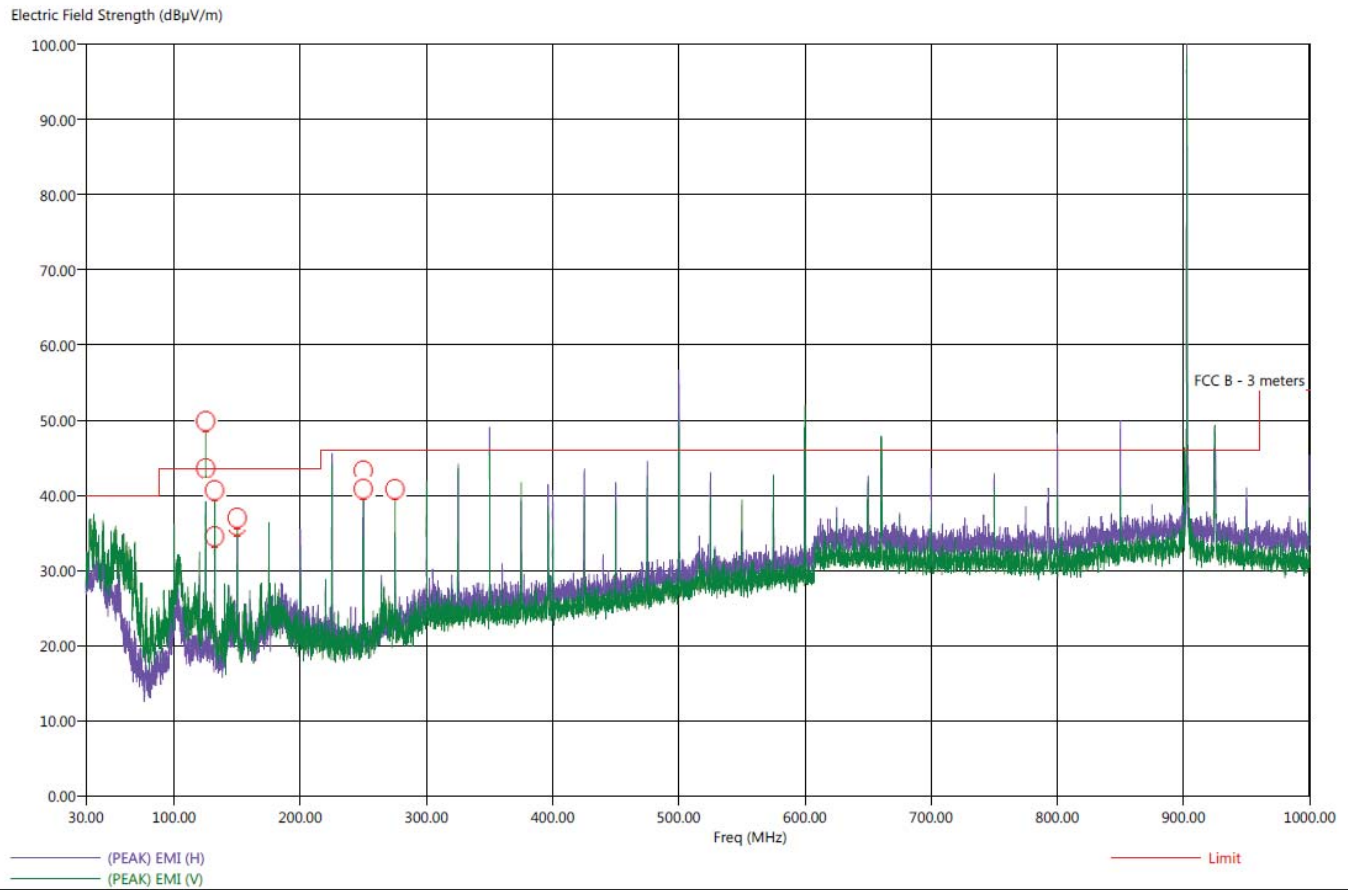

Title: Radiated Final - FCC Class B  
 File: 4 - Agilent - Final Scan - PULSE - FCC Class B.set  
 Operator: Kyle Fujimoto  
 EUT Type: VPx Access Point  
 EUT Condition: The EUT is continuously transmitting at 902.62 MHz - X-Axis Worst Case  
 Comments: Company: Mesa Labs, Inc.  
 Model: CM-000250  
 With PULSE Antenna

8/1/2016 2:41:05 PM  
 Sequence: Final Measurements

FCC Class B										
Freq (MHz)	Pol	(PEAK) EMI (dBµV/m)	(QP) EMI (dBµV/m)	(PEAK) Margin (dB)	(QP) Margin (dB)	Limit (dBµV/m)	Transducer (dB)	Cable (dB)	Ttbl Agl (deg)	Twr Ht (cm)
125.00	H	38.62	37.24	-4.88	-6.26	43.50	15.40	0.81	298.50	399.43
125.00	V	41.54	40.53	-1.96	-2.97	43.50	15.40	0.81	170.00	127.07
132.10	H	36.82	35.58	-6.68	-7.92	43.50	14.28	0.84	308.75	271.61
132.10	V	41.10	40.21	-2.40	-3.29	43.50	14.27	0.84	312.50	111.25
150.00	H	38.75	37.37	-4.75	-6.13	43.50	17.20	0.90	285.75	303.73
150.00	V	42.27	40.90	-1.23	-2.60	43.50	17.19	0.90	0.75	111.19
250.00	H	55.46	54.94	9.46	8.94	46.00	15.30	1.24	227.75	143.19
250.00	V	51.29	50.59	5.29	4.59	46.00	15.30	1.24	278.00	255.25
275.00	V	35.86	34.10	-10.14	-11.90	46.00	16.82	1.28	310.00	319.49

Note #1: The Frequencies taken above are all inside Restricted Band frequencies per section 15.205.

Note #2: The frequency at 250 MHz was re-taken to the Class A limits below with the transmitter portion shut off to prove that it was coming from the digital portion.

250.00	H	55.51	55.02	-1.38	-1.87	56.89	15.30	1.24	227.75	143.19
250.00	V	51.42	50.67	-5.47	-6.22	56.89	15.30	1.24	278.00	255.25



Title: Pre-Scan - FCC Class B  
 File: 5 - Agilent - Pre-Scan - L-COM - FCC Class B.set  
 Operator: Kyle Fujimoto  
 EUT Type: VPx Access Point  
 EUT Condition: The EUT is continuously transmitting at 902.62 MHz - X-Axis Worst Case  
 Comments: Company: Mesa Labs, Inc.  
 Model: CM-000250  
 With L-COM Antenna  
 Note: The frequencies not marked are all outside the restricted bands of FCC 15.205 and thus not subject to FCC Class B Limits

8/1/2016 3:19:31 PM  
 Sequence: Preliminary Scan

FCC Class B and FCC 15.247

Electric Field Strength (dBuV/m)

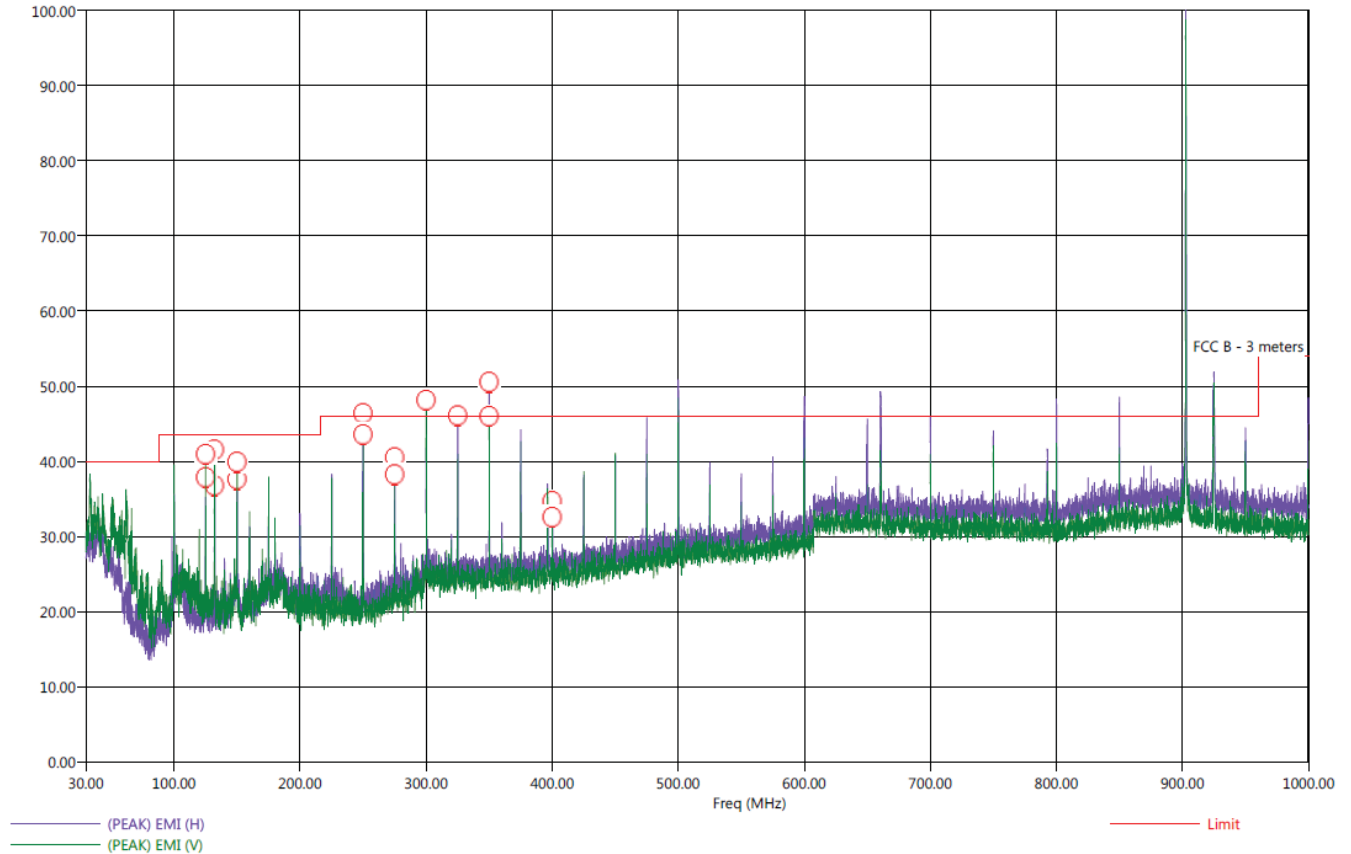

Title: Radiated Final - FCC Class B  
 File: 5 - Agilent - Final Scan - L-COM - FCC Class B.set  
 Operator: Kyle Fujimoto  
 EUT Type: VPx Access Point  
 EUT Condition: The EUT is continuously transmitting at 902.62 MHz - X-Axis Worst Case  
 Comments: Company: Mesa Labs, Inc.  
 Model: CM-000250  
 With L-Com Antenna

8/1/2016 3:32:36 PM  
 Sequence: Final Measurements

FCC Class B										
Freq (MHz)	Pol	(PEAK) EMI (dBµV/m)	(QP) EMI (dBµV/m)	(PEAK) Margin (dB)	(QP) Margin (dB)	Limit (dBµV/m)	Transducer (dB)	Cable (dB)	Ttbl Agl (deg)	Twr Ht (cm)
125.00	H	42.17	41.43	-1.33	-2.07	43.50	15.40	0.81	214.75	335.67
125.00	V	40.27	39.36	-3.23	-4.14	43.50	15.40	0.81	240.25	319.31
132.10	H	37.05	35.76	-6.45	-7.74	43.50	14.28	0.84	309.50	255.67
132.10	V	43.38	42.42	-0.12	-1.08	43.50	14.27	0.84	131.25	111.07
150.00	H	36.07	34.62	-7.43	-8.88	43.50	17.20	0.90	247.75	303.43
150.00	V	41.90	40.67	-1.60	-2.83	43.50	17.20	0.90	85.50	111.01
250.00	H	48.67	48.13	2.67	2.13	46.00	15.30	1.24	201.00	143.13
250.00	V	44.07	43.49	-1.93	-2.51	46.00	15.30	1.24	136.00	110.95
275.00	H	42.10	40.38	-3.90	-5.62	46.00	16.82	1.28	199.00	174.71
275.00	V	37.39	35.50	-8.61	-10.50	46.00	16.82	1.28	256.25	368.50
325.00	H	47.05	46.51	1.05	0.51	46.00	18.04	1.42	138.50	111.07
325.00	V	49.82	48.76	3.82	2.76	46.00	18.04	1.42	89.50	111.19
400.00	H	37.05	34.13	-8.95	-11.87	46.00	18.60	1.56	117.75	110.89
400.00	V	38.08	35.93	-7.92	-10.07	46.00	18.60	1.56	190.25	111.31

Note #1: The Frequencies taken above are all inside Restricted Band frequencies per section 15.205.

Note #2: The frequencies at 250 MHz and 325 MHz were re-taken to the Class A limit below with the transmitter portion shut off to prove that it was coming from the digital portion.

250.00	H	48.65	48.12	-8.24	-8.77	56.89	15.30	1.24	201.00	143.13
325.00	H	46.99	45.44	-9.90	-11.45	56.89	18.04	1.42	138.50	111.07
325.00	V	49.76	48.67	-7.13	-8.22	56.89	18.04	1.42	89.50	111.19



Title: Pre-Scan - FCC Class A  
 File: 1 - Agilent - Pre-Scan - L-COM - FCC Class A.set  
 Operator: Kyle Fujimoto  
 EUT Type: VPx Access Point  
 EUT Condition: The EUT is idle - X-Axis Worst Case  
 Comments: Company: Mesa Labs, Inc.  
 Model: CM-000250  
 With L-COM Antenna  
 The RF Module is Powered off completely - Only Main Board is Active  
 Note #1: The emissions do not go higher when the Rx portion is then activated  
 Note #2: No additional emissions are detected when the Rx portion is then activated

8/1/2016 10:09:53 AM  
 Sequence: Preliminary Scan

FCC Class A

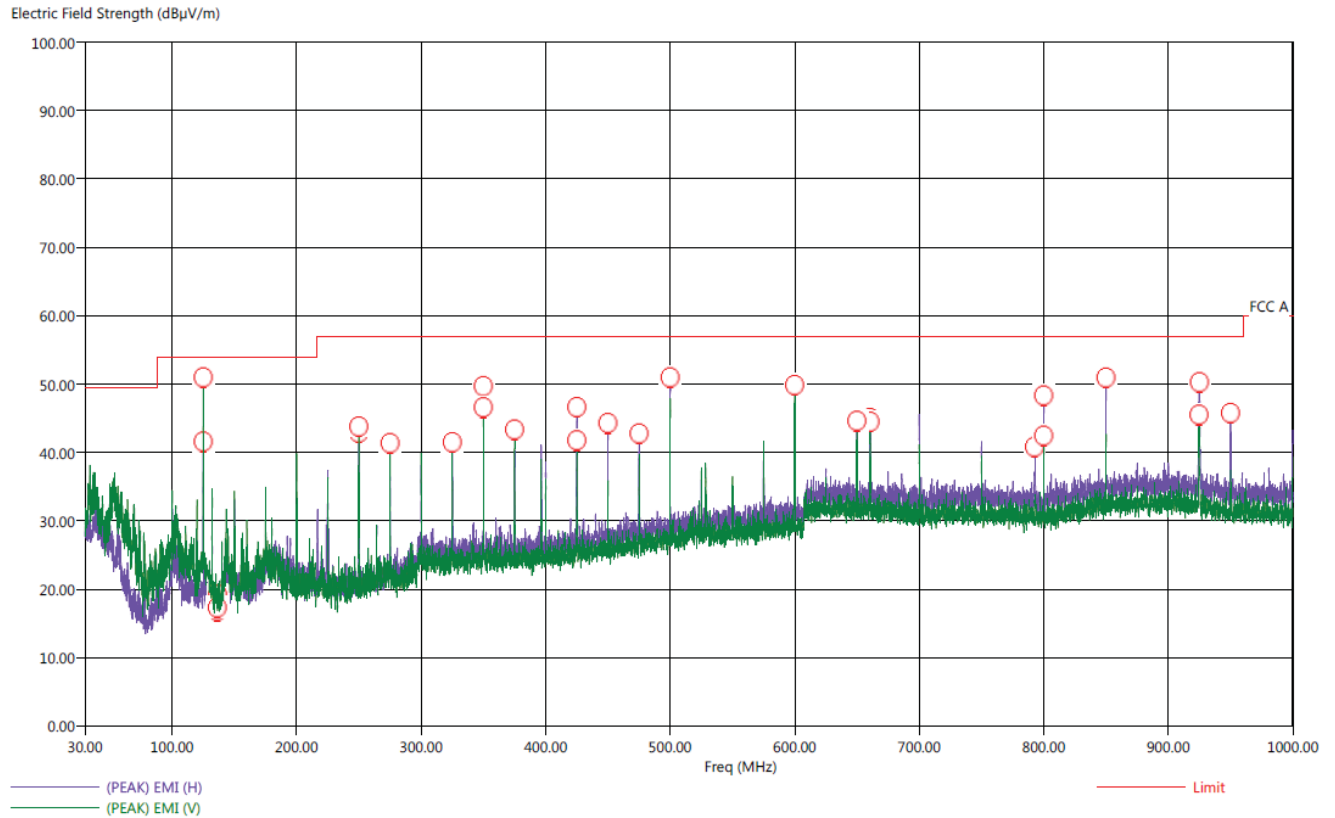



Title: Radiated Final - FCC Class A  
 File: 1 - Agilent - Final Scan - L-COM - FCC Class A.set  
 Operator: Kyle Fujimoto  
 EUT Type: VPx Access Point  
 EUT Condition: The EUT is idle - X-Axis Worst Case  
 Comments: Company: Mesa Labs, Inc.  
 Model: CM-000250  
 With L-COM Antenna  
 The RF Module is Powered off completely - Only Main Board is Active

8/1/2016 10:34:29 AM  
 Sequence: Final Measurements

Note #1: The emissions do not go higher when the Rx portion is then activated  
 Note #2: No additional emissions are detected when the Rx portion is then activated

FCC Class A

Freq (MHz)	Pol	(PEAK) EMI (dBµV/m)	(QP) EMI (dBµV/m)	(PEAK) Margin (dB)	(QP) Margin (dB)	Limit (dBµV/m)	Transducer (dB)	Cable (dB)	Ttbl Agl (deg)	Twr Ht (cm)
125.00	H	37.76	36.17	-16.21	-17.80	53.97	15.40	0.81	138.25	302.83
125.00	V	42.34	41.49	-11.63	-12.48	53.97	15.40	0.81	152.75	111.37
250.00	H	45.95	45.49	-10.94	-11.40	56.89	15.30	1.24	232.25	111.67
250.00	V	46.11	45.05	-10.78	-11.84	56.89	15.30	1.24	140.75	111.31
275.00	V	44.55	43.08	-12.34	-13.81	56.89	16.82	1.28	71.75	128.02
325.00	V	45.13	44.06	-11.76	-12.83	56.89	18.04	1.42	84.75	111.43
350.00	H	50.78	50.05	-6.11	-6.84	56.89	17.90	1.46	276.50	111.07
350.00	V	49.03	48.49	-7.86	-8.40	56.89	17.90	1.46	142.00	111.25
375.00	V	45.28	44.18	-11.61	-12.71	56.89	18.26	1.51	117.00	126.83
425.00	H	43.63	42.19	-13.26	-14.70	56.89	19.22	1.64	236.75	223.13
425.00	V	45.24	44.12	-11.65	-12.77	56.89	19.22	1.64	225.50	127.25
450.00	H	40.05	37.71	-16.84	-19.18	56.89	19.80	1.71	57.75	271.43
475.00	H	46.25	44.83	-10.64	-12.06	56.89	20.72	1.73	49.50	111.19
500.00	H	52.35	50.87	-4.54	-6.02	56.89	21.60	1.74	51.50	113.58
600.00	V	50.01	48.53	-6.88	-8.36	56.89	23.70	1.97	165.25	162.23
650.00	V	41.98	38.23	-14.91	-18.66	56.89	24.30	2.11	161.75	159.13
660.60	H	53.20	48.64	-3.69	-8.25	56.89	24.23	2.11	218.50	110.95
660.60	V	48.52	46.81	-8.37	-10.08	56.89	24.23	2.11	245.00	111.07
792.70	H	46.32	43.63	-10.57	-13.26	56.89	24.33	2.16	227.75	111.43
800.00	H	51.64	50.48	-5.25	-6.41	56.89	24.30	2.35	308.50	111.49
800.00	V	47.90	46.11	-8.99	-10.78	56.89	24.30	2.35	266.25	159.25
850.00	H	48.41	45.60	-8.48	-11.29	56.89	26.30	2.49	201.25	287.43
924.70	V	54.76	52.61	-2.13	-4.28	56.89	26.45	2.58	168.75	111.31
925.00	H	50.15	47.52	-6.74	-9.37	56.89	26.45	2.58	101.50	174.95
950.00	H	43.55	41.56	-13.34	-15.33	56.89	26.00	2.63	88.00	255.25



Title: Pre-Scan - FCC Class A  
 File: 2 - Agilent - Pre-Scan - PULSE - FCC Class A.set  
 Operator: Kyle Fujimoto  
 EUT Type: VPx Access Point  
 EUT Condition: The EUT is idle - X-Axis Worst Case  
 Comments: Company: Mesa Labs, Inc.  
 Model: CM-000250  
 With Pulse Antenna  
 The RF Module is Powered off completely - Only Main Board is Active  
 Note #1: The emissions do not go higher when the Rx portion is then activated  
 Note #2: No additional emissions are detected when the Rx portion is then activated

8/1/2016 11:42:53 AM  
 Sequence: Preliminary Scan

FCC Class A

Electric Field Strength (dB $\mu$ V/m)

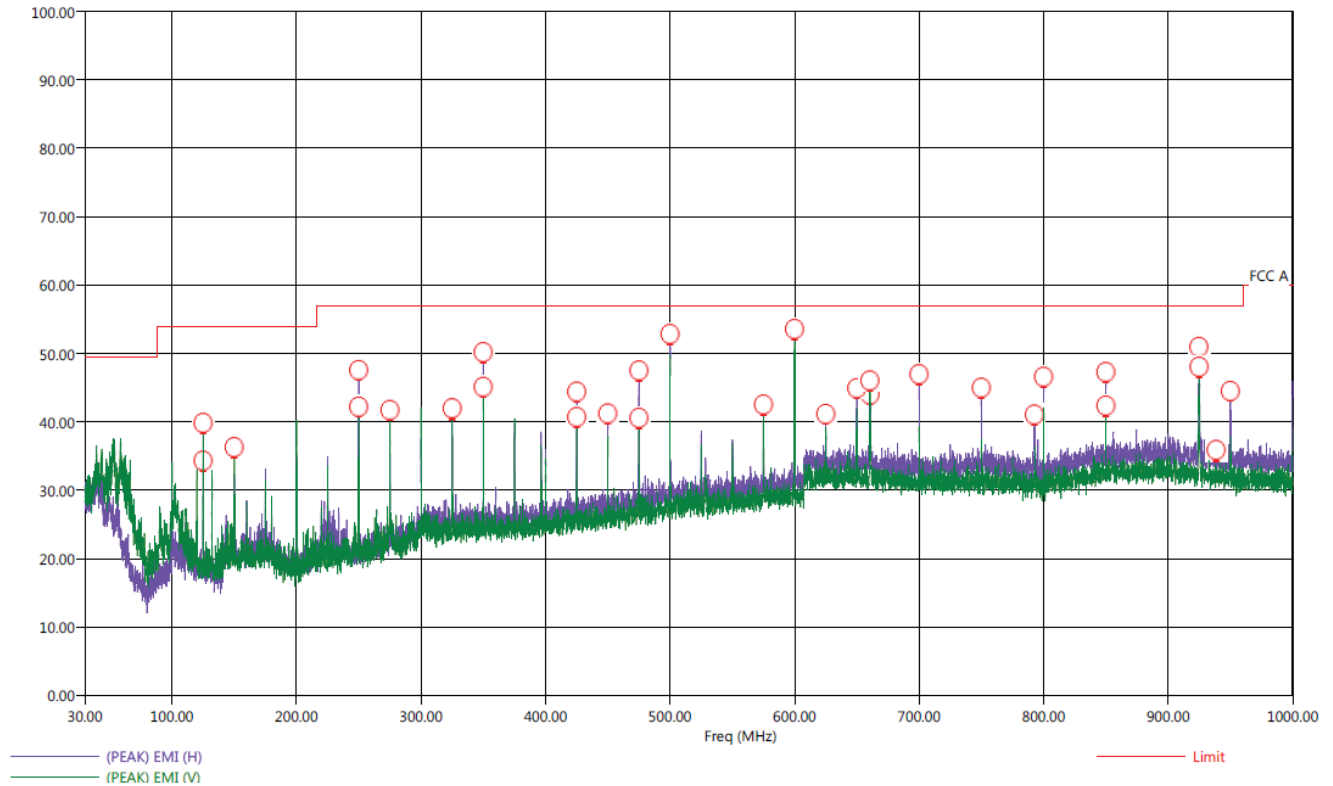

Title: Radiated Final - FCC Class A  
 File: 2 - Agilent - Final Scan - PULSE - FCC Class A.set  
 Operator: Kyle Fujimoto  
 EUT Type: VPx Access Point  
 EUT Condition: The EUT is idle - X-Axis Worst Case  
 Comments: Company: Mesa Labs, Inc.  
 Model: CM-000250  
 With PULSE Antenna  
 The RF Module is Powered off completely - Only Main Board is Active  
 Note #1: The emissions do not go higher when the Rx portion is then activated  
 Note #2: No additional emissions are detected when the Rx portion is then activated

8/1/2016 11:55:36 AM  
 Sequence: Final Measurements

FCC Class A

Freq (MHz)	Pol	(PEAK) EMI (dBµV/m)	(QP) EMI (dBµV/m)	(PEAK) Margin (dB)	(QP) Margin (dB)	Limit (dBµV/m)	Transducer (dB)	Cable (dB)	Ttbl Agl (deg)	Twr Ht (cm)
125.00	H	37.48	36.41	-16.49	-17.56	53.97	15.40	0.81	142.25	274.65
125.00	V	42.61	41.79	-11.36	-12.18	53.97	15.40	0.81	154.00	111.07
150.00	V	37.53	35.39	-16.44	-18.58	53.97	17.19	0.90	68.75	112.32
250.00	H	50.30	49.65	-6.59	-7.24	56.89	15.30	1.24	242.75	111.25
250.00	V	40.07	38.78	-16.82	-18.11	56.89	15.30	1.24	148.50	191.55
275.00	V	43.15	41.12	-13.74	-15.77	56.89	16.82	1.28	68.25	113.10
325.00	H	41.99	40.44	-14.90	-16.45	56.89	18.04	1.42	138.50	111.07
325.00	V	44.76	43.67	-12.13	-13.22	56.89	18.04	1.42	89.50	111.19
350.00	H	51.07	50.32	-5.82	-6.57	56.89	17.90	1.46	280.00	111.43
350.00	V	49.11	47.80	-7.78	-9.09	56.89	17.90	1.46	154.25	111.43
425.00	H	43.24	41.88	-13.65	-15.01	56.89	19.22	1.64	93.25	223.31
425.00	V	45.04	43.61	-11.85	-13.28	56.89	19.22	1.64	234.00	111.13
450.00	H	42.76	41.59	-14.13	-15.30	56.89	19.80	1.71	52.00	111.13
475.00	H	46.04	45.03	-10.85	-11.86	56.89	20.72	1.73	49.00	111.19
475.00	V	46.06	44.89	-10.83	-12.00	56.89	20.72	1.73	66.50	127.37
500.00	V	55.02	53.47	-1.87	-3.42	56.89	21.60	1.74	69.50	148.26
575.00	V	49.71	48.20	-7.18	-8.69	56.89	23.06	1.94	58.25	111.13
600.00	V	55.19	53.64	-1.70	-3.25	56.89	23.70	1.97	98.25	164.21
625.00	H	44.69	42.33	-12.20	-14.56	56.89	24.01	2.04	172.75	127.19
650.00	H	48.90	47.24	-7.99	-9.65	56.89	24.30	2.11	190.50	111.25
660.60	V	50.42	48.66	-6.47	-8.23	56.89	24.23	2.11	264.75	111.01
660.70	H	52.14	50.43	-4.75	-6.46	56.89	24.23	2.11	239.00	111.31
700.00	H	48.31	46.39	-8.58	-10.50	56.89	24.00	2.13	197.25	111.07
750.00	H	47.77	44.36	-9.12	-12.53	56.89	24.50	2.39	170.25	111.25
792.70	H	46.29	44.06	-10.60	-12.83	56.89	24.33	2.36	219.00	112.62
800.00	H	51.48	48.50	-5.41	-8.39	56.89	24.30	2.35	308.00	112.38
850.00	H	46.23	44.34	-10.66	-12.55	56.89	26.30	2.49	136.75	271.37
850.00	V	45.19	43.32	-11.70	-13.57	56.89	26.30	2.49	265.75	223.25
924.80	H	49.94	47.50	-6.95	-9.39	56.89	26.45	2.58	100.25	175.07
924.90	V	53.58	50.51	-3.31	-6.38	56.89	26.45	2.58	164.75	112.20
938.60	H	37.95	32.13	-18.94	-24.76	56.89	26.20	2.61	288.75	351.55
938.70	H	37.14	32.16	-19.75	-24.73	56.89	26.20	2.61	0.00	271.67
950.00	H	43.38	39.16	-13.51	-17.73	56.89	26.00	2.63	90.00	158.41



***CONDUCTED EMISSIONS  
DATA SHEETS***

Title: FCC Class B - Conducted Emissions - Black Lead  
 File: Agilent - Conducted - Pre-Test - Line - L-COM - VPx Access Point - Tx Mode - FCC Class B.set  
 Operator: Kyle Fujimoto  
 EUT Type: VPx Access Point  
 EUT Condition: The EUT was continuously frequency hopping  
 Comments: Company: Mesa Labs, Inc.  
 Model: CM-000250  
 With L-COM Antenna

7/27/2016 10:48:55 AM  
 Sequence: Preliminary Scan

FCC Class B - Conducted Emissions - Black Lead

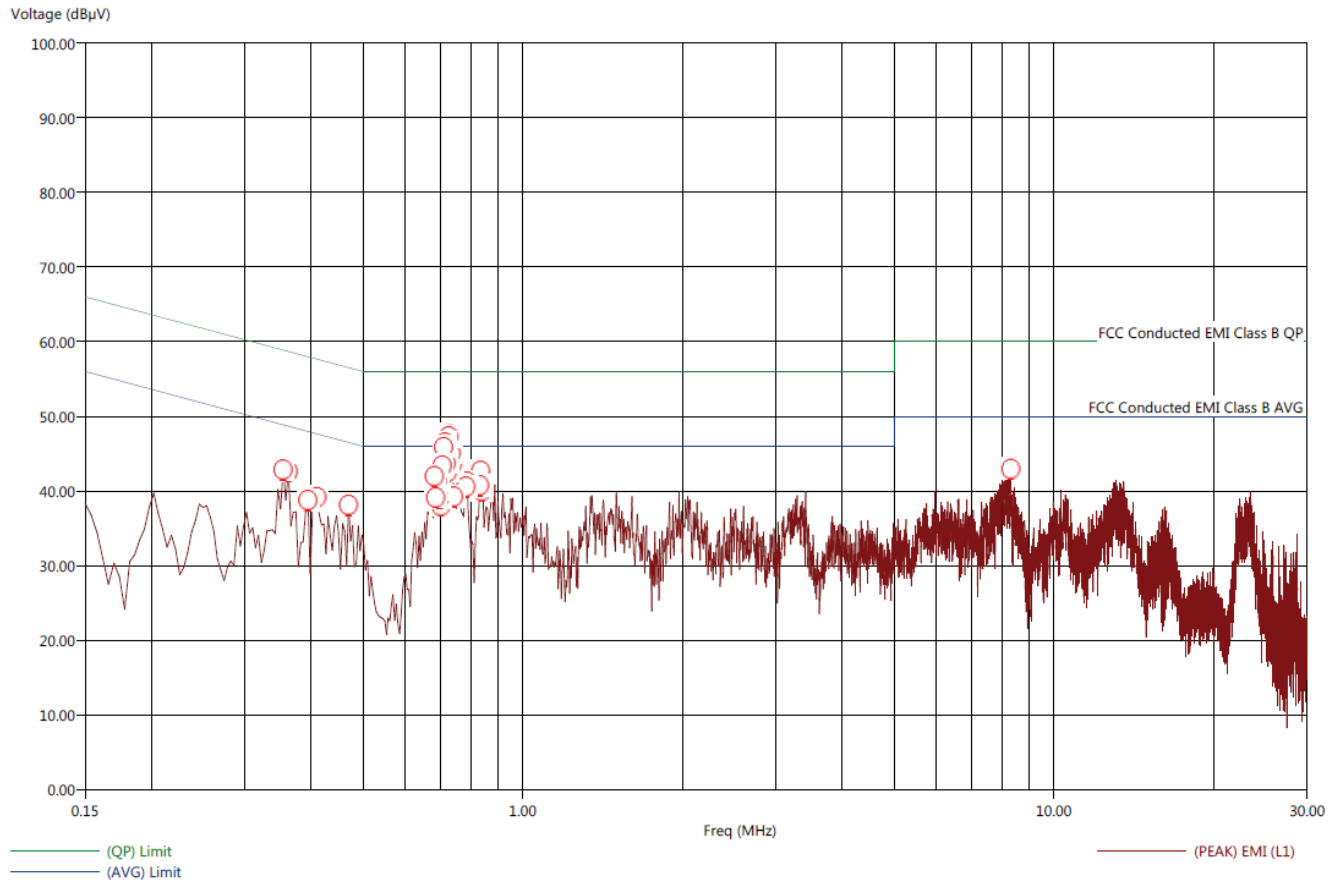

Title: FCC Class B - Conducted Emissions - Black Lead  
 File: Agilent - Conducted - Final Test - Line - L-COM - VPx Access Point - Tx Mode - FCC Class B.set  
 Operator: Kyle Fujimoto  
 EUT Type: VPx Access Point  
 EUT Condition: The EUT was continuously frequency hopping  
 Comments: Company: Mesa Labs, Inc.  
 Model: CM-000250  
 With L-COM Antenna

7/27/2016 10:52:36 AM  
 Sequence: Final Measurements

FCC Class B - Conducted Emissions - Black Lead

Freq (MHz)	(PEAK) EMI (dBµV)	(AVG) EMI (dBµV)	(PEAK) Margin AVL (dB)	(AVG) Margin AVL (dB)	(AVG) Limit (dBµV)	Cable (dB)	Transducer (dB)	Filter (dB)
0.354	43.99	33.73	-4.81	-15.07	48.80	0.08	0.04	9.84
0.362	43.42	34.50	-5.51	-14.43	48.93	0.08	0.04	9.84
0.394	42.55	34.31	-5.25	-13.49	47.80	0.08	0.05	9.84
0.410	41.72	32.53	-5.85	-15.04	47.57	0.08	0.05	9.84
0.470	41.22	31.90	-5.70	-15.02	46.92	0.08	0.05	9.84
0.682	46.90	38.16	0.90	-7.84	46.00	0.09	0.04	9.84
0.686	48.13	39.04	2.13	-6.96	46.00	0.09	0.04	9.84
0.690	48.57	39.54	2.57	-6.46	46.00	0.10	0.04	9.84
0.694	48.47	40.28	2.47	-5.72	46.00	0.10	0.04	9.84
0.698	49.11	41.58	3.11	-4.42	46.00	0.10	0.04	9.84
0.702	49.42	41.44	3.42	-4.56	46.00	0.10	0.04	9.84
0.706	48.78	40.11	2.78	-5.89	46.00	0.10	0.04	9.84
0.710	49.46	41.70	3.46	-4.30	46.00	0.10	0.04	9.84
0.714	49.04	40.95	3.04	-5.05	46.00	0.10	0.04	9.84
0.718	48.49	40.10	2.49	-5.90	46.00	0.10	0.04	9.84
0.722	49.37	40.94	3.37	-5.06	46.00	0.10	0.04	9.84
0.726	49.24	41.21	3.24	-4.79	46.00	0.10	0.04	9.84
0.730	49.51	41.55	3.51	-4.45	46.00	0.10	0.04	9.84
0.734	48.91	41.27	2.91	-4.73	46.00	0.10	0.04	9.84
0.738	49.36	41.24	3.36	-4.76	46.00	0.10	0.04	9.84
0.742	49.00	41.61	3.00	-4.39	46.00	0.10	0.04	9.84
0.782	43.00	31.64	-3.00	-14.36	46.00	0.10	0.04	9.84
0.786	47.38	38.23	1.38	-7.77	46.00	0.10	0.04	9.84
0.830	44.16	33.74	-1.84	-12.26	46.00	0.10	0.04	9.84
0.834	42.03	33.29	-3.97	-12.71	46.00	0.10	0.04	9.84
0.838	42.81	33.94	-3.19	-12.06	46.00	0.10	0.04	9.84
8.306	44.54	35.45	-5.46	-14.55	50.00	0.33	0.03	10.02



Title: FCC Class B - Conducted Emissions - White Lead  
 File: Agilent - Conducted - Pre-Test - Neutral - L-COM - VPx Access Point - Tx Mode - FCC Class B.set  
 Operator: Kyle Fujimoto  
 EUT Type: VPx Access Point  
 EUT Condition: The EUT was continuously frequency hopping  
 Comments: Company: Mesa Labs, Inc.  
 Model: CM-000250  
 With L-COM Antenna

7/27/2016 10:56:52 AM  
 Sequence: Preliminary Scan

FCC Class B - Conducted Emissions - White Lead

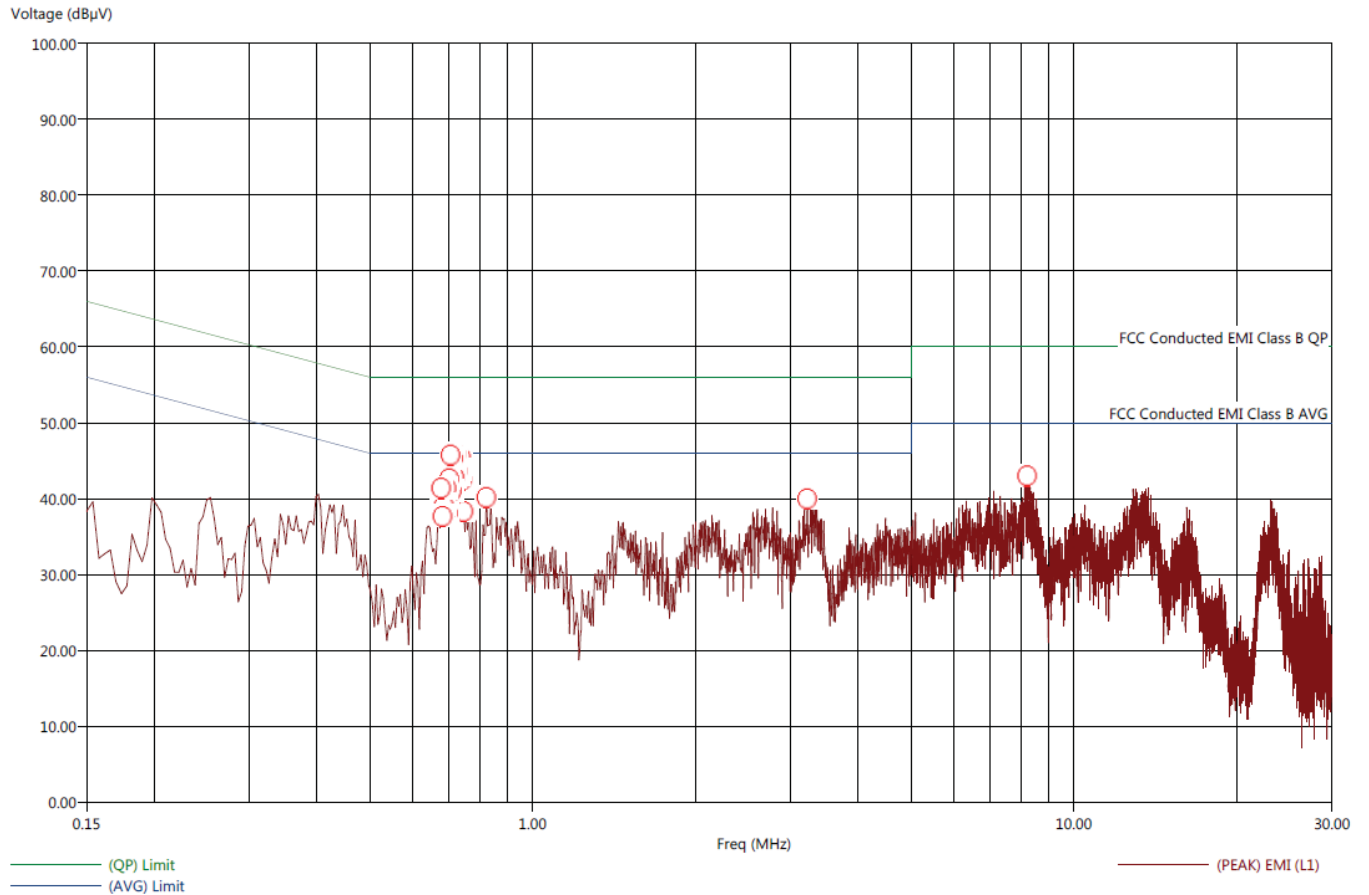



Title: FCC Class B - Conducted Emissions - White Lead  
 File: Agilent - Conducted - Final Test - Neutral - L-COM - VPx Access Point - Tx Mode - FCC Class B.set  
 Operator: Kyle Fujimoto  
 EUT Type: VPx 900 MHz Access Point  
 EUT Condition: The EUT was continuously frequency hopping  
 Comments: Company: Mesa Labs, Inc.  
 Model: CM-000250  
 With L-Com Antenna

7/27/2016 10:59:36 AM  
 Sequence: Final Measurements

FCC Class B - Conducted Emissions - White Lead

Freq (MHz)	(PEAK) EMI (dBµV)	(AVG) EMI (dBµV)	(PEAK) Margin AVL (dB)	(AVG) Margin AVL (dB)	(AVG) Limit (dBµV)	Cable (dB)	Transducer (dB)	Filter (dB)
0.678	48.91	40.95	2.91	-5.05	46.00	0.10	0.03	9.84
0.682	46.14	37.97	0.14	-8.03	46.00	0.09	0.03	9.84
0.686	47.71	39.64	1.71	-6.36	46.00	0.10	0.03	9.84
0.690	47.56	39.46	1.56	-6.54	46.00	0.10	0.03	9.84
0.694	47.92	39.64	1.92	-6.36	46.00	0.10	0.03	9.84
0.698	48.06	39.71	2.06	-6.29	46.00	0.10	0.03	9.84
0.702	49.04	41.03	3.04	-4.97	46.00	0.10	0.03	9.84
0.706	48.91	41.59	2.91	-4.41	46.00	0.10	0.03	9.84
0.710	48.77	41.59	2.77	-4.41	46.00	0.10	0.03	9.84
0.714	49.17	41.11	3.17	-4.89	46.00	0.10	0.03	9.84
0.718	49.31	41.56	3.31	-4.44	46.00	0.10	0.03	9.84
0.722	48.76	41.48	2.76	-4.52	46.00	0.10	0.03	9.84
0.726	48.85	41.31	2.85	-4.69	46.00	0.10	0.03	9.84
0.730	48.32	40.50	2.32	-5.50	46.00	0.10	0.03	9.84
0.734	48.50	40.44	2.50	-5.56	46.00	0.10	0.03	9.84
0.738	48.85	40.90	2.85	-5.10	46.00	0.10	0.03	9.84
0.742	48.94	41.15	2.94	-4.85	46.00	0.10	0.03	9.84
0.746	48.71	41.11	2.71	-4.89	46.00	0.10	0.03	9.84
0.822	42.01	33.45	-3.99	-12.55	46.00	0.10	0.03	9.84
3.218	40.75	32.82	-5.25	-13.18	46.00	0.20	0.04	9.89
8.202	44.88	34.89	-5.12	-15.11	50.00	0.33	0.03	10.02



Title: FCC Class B - Conducted Emissions - Black Lead  
 File: Agilent - Conducted - Pre-Test - Line - L-COM - VPx Access Point - Rx Mode - FCC Class B.set  
 Operator: Kyle Fujimoto  
 EUT Type: VPx Access Point  
 EUT Condition: The EUT was continuously receiving  
 Comments: Company: Mesa Labs, Inc.  
 Model: CM-000250  
 With L-COM Antenna

7/27/2016 11:38:09 AM  
 Sequence: Preliminary Scan

FCC Class B - Conducted Emissions - Black Lead

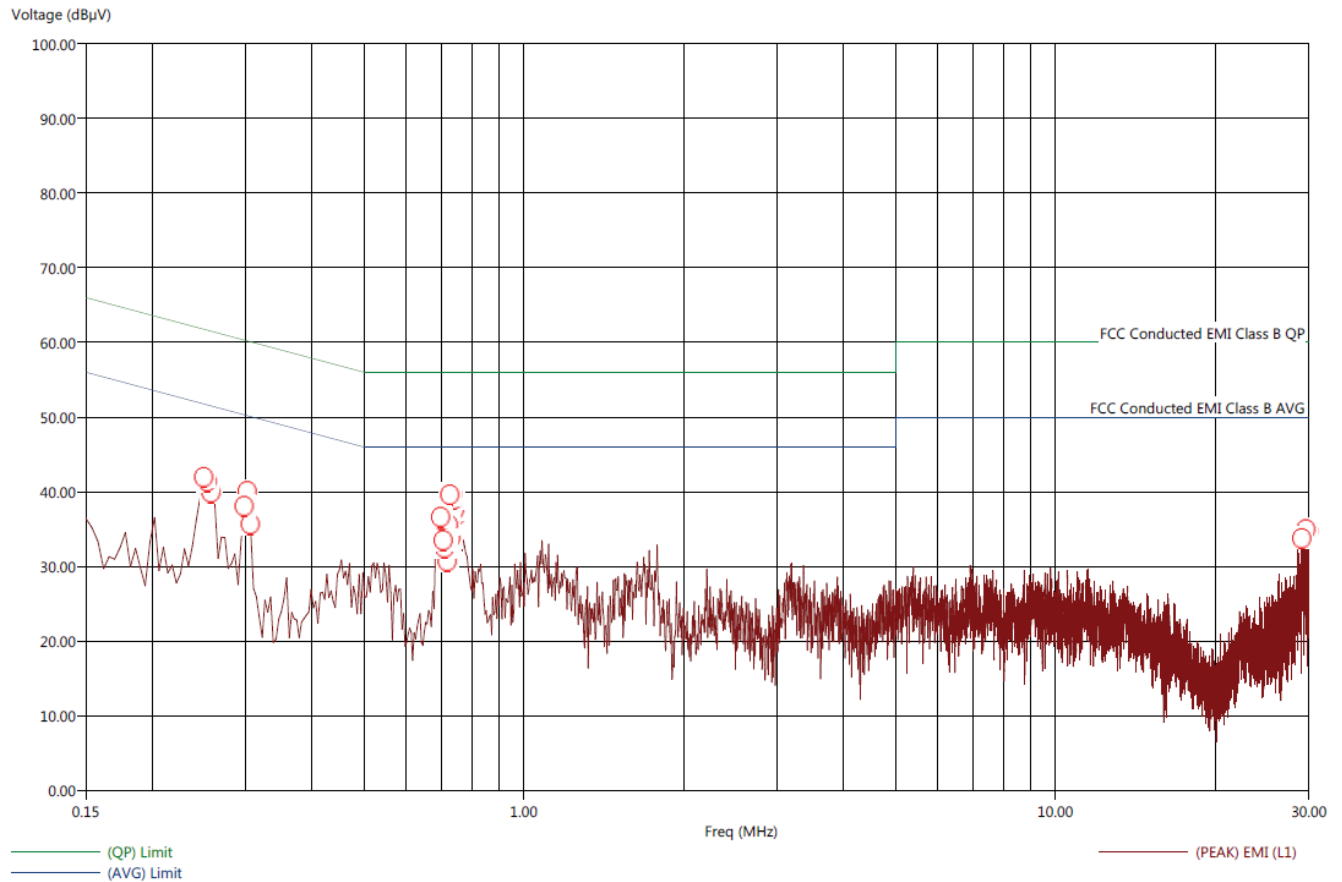

Title: FCC Class B - Conducted Emissions - Black Lead  
 File: Agilent - Conducted - Final Test - Line - L-COM - VPx Access Point - Rx Mode - FCC Class B.set  
 Operator: Kyle Fujimoto  
 EUT Type: VPx Access Point  
 EUT Condition: The EUT was continuously receiving  
 Comments: Company: Mesa Labs, Inc.  
 Model: CM-000250  
 With L-COM Antenna

7/27/2016 11:39:55 AM  
 Sequence: Final Measurements

## FCC Class B - Conducted Emissions - Black Lead

Freq (MHz)	(PEAK) EMI (dBµV)	(AVG) EMI (dBµV)	(PEAK) Margin AVL (dB)	(AVG) Margin AVL (dB)	(AVG) Limit (dBµV)	Cable (dB)	Transducer (dB)	Filter (dB)
0.250	43.56	28.25	-8.04	-23.35	51.60	0.08	0.22	9.83
0.254	44.30	28.42	-7.47	-23.35	51.77	0.08	0.23	9.83
0.258	44.04	28.87	-7.59	-22.76	51.63	0.08	0.22	9.83
0.298	41.05	25.50	-9.23	-24.78	50.28	0.08	0.13	9.83
0.302	40.96	24.90	-9.38	-25.44	50.34	0.08	0.13	9.83
0.306	41.44	25.45	-8.85	-24.84	50.29	0.08	0.13	9.83
0.698	41.25	30.31	-4.75	-15.69	46.00	0.10	0.04	9.84
0.702	39.85	28.68	-6.15	-17.32	46.00	0.10	0.04	9.84
0.706	40.83	31.28	-5.17	-14.72	46.00	0.10	0.04	9.84
0.710	40.57	30.65	-5.43	-15.35	46.00	0.10	0.04	9.84
0.714	41.47	31.46	-4.53	-14.54	46.00	0.10	0.04	9.84
0.718	41.09	31.33	-4.91	-14.67	46.00	0.10	0.04	9.84
0.722	40.97	30.94	-5.03	-15.06	46.00	0.10	0.04	9.84
0.726	40.99	31.46	-5.01	-14.54	46.00	0.10	0.04	9.84
0.730	41.31	30.85	-4.69	-15.15	46.00	0.10	0.04	9.84
0.734	41.48	31.57	-4.52	-14.43	46.00	0.10	0.04	9.84
0.738	40.98	30.94	-5.02	-15.06	46.00	0.10	0.04	9.84
0.742	41.16	31.01	-4.84	-14.99	46.00	0.10	0.04	9.84
0.746	41.18	30.76	-4.82	-15.24	46.00	0.10	0.04	9.84
0.750	41.04	31.55	-4.96	-14.45	46.00	0.10	0.04	9.84
29.110	38.22	24.75	-11.78	-25.25	50.00	0.72	0.27	10.65
29.618	38.83	22.59	-11.17	-27.41	50.00	0.74	0.28	10.68
29.954	38.14	24.32	-11.86	-25.68	50.00	0.72	0.27	10.65



Title: FCC Class B - Conducted Emissions - White Lead  
 File: Agilent - Conducted - Pre-Test - Neutral - L-COM - VPx Access Point - Rx Mode - FCC Class B.set  
 Operator: Kyle Fujimoto  
 EUT Type: VPx Access Point  
 EUT Condition: The EUT was continuously receiving  
 Comments: Company: Mesa Labs, Inc.  
 Model: CM-000250  
 With L-COM Antenna

7/27/2016 11:34:08 AM  
 Sequence: Preliminary Scan

FCC Class B - Conducted Emissions - White Lead

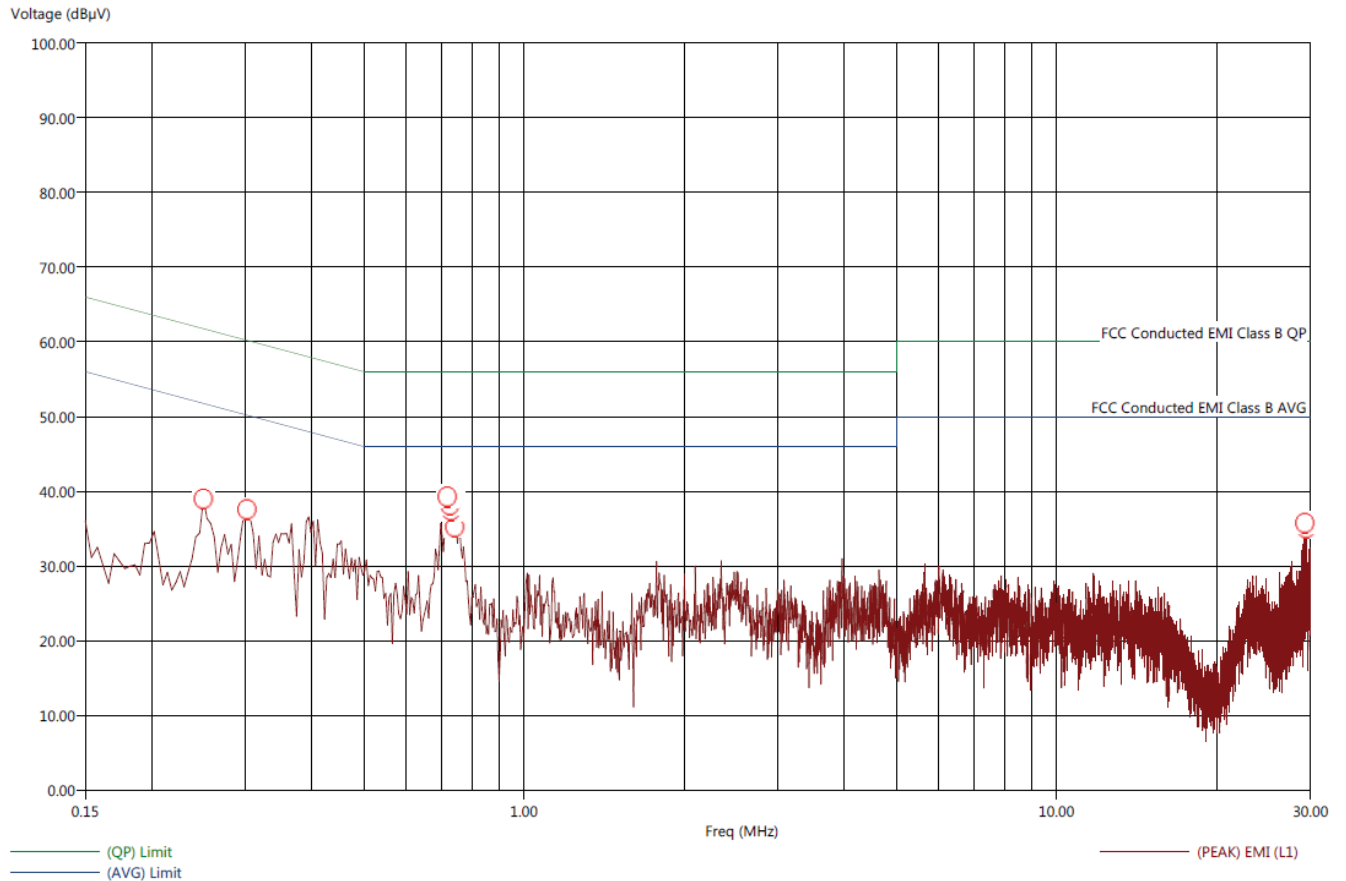

Title: FCC Class B - Conducted Emissions - White Lead  
 File: Agilent - Conducted - Final Test - Neutral - L-COM - VPx Access Point - Rx Mode - FCC Class B.set  
 Operator: Kyle Fujimoto  
 EUT Type: VPx Access Point  
 EUT Condition: The EUT was continuously receiving  
 Comments: Company: Mesa Labs, Inc.  
 Model:CM-000250  
 With L-COM Antenna

7/27/2016 11:35:31 AM  
 Sequence: Final Measurements

**FCC Class B - Conducted Emissions - White Lead**

Freq (MHz)	(PEAK) EMI (dBµV)	(AVG) EMI (dBµV)	(PEAK) Margin AVL (dB)	(AVG) Margin AVL (dB)	(AVG) Limit (dBµV)	Cable (dB)	Transducer (dB)	Filter (dB)
0.250	46.12	35.91	-5.57	-15.78	51.70	0.08	0.21	9.83
0.302	44.31	31.96	-5.78	-18.13	50.09	0.08	0.11	9.83
0.718	40.89	32.67	-5.11	-13.33	46.00	0.10	0.03	9.84
0.722	40.75	33.59	-5.25	-12.41	46.00	0.10	0.03	9.84
0.726	41.03	33.75	-4.97	-12.25	46.00	0.10	0.03	9.84
0.730	41.03	33.61	-4.97	-12.39	46.00	0.10	0.03	9.84
0.734	40.86	33.79	-5.14	-12.21	46.00	0.10	0.03	9.84
0.738	41.10	33.75	-4.90	-12.25	46.00	0.10	0.03	9.84
0.742	40.81	33.66	-5.19	-12.34	46.00	0.10	0.03	9.84
29.282	37.06	22.40	-12.94	-27.60	50.00	0.72	0.11	10.64
29.470	38.83	25.28	-11.17	-24.72	50.00	0.72	0.12	10.65



Title: FCC Class B - Conducted Emissions - Black Lead  
 File: Agilent - Conducted - Pre-Test - Line - PULSE - VPx Access Point - Tx Mode - FCC Class B.set  
 Operator: Kyle Fujimoto  
 EUT Type: VPx Access Point  
 EUT Condition: The EUT was continuously frequency hopping  
 Comments: Company: Mesa Labs, Inc.  
 Model: CM-000250  
 With PULSE Antenna

7/27/2016 11:05:32 AM  
 Sequence: Preliminary Scan

FCC Class B - Conducted Emissions - Black Lead

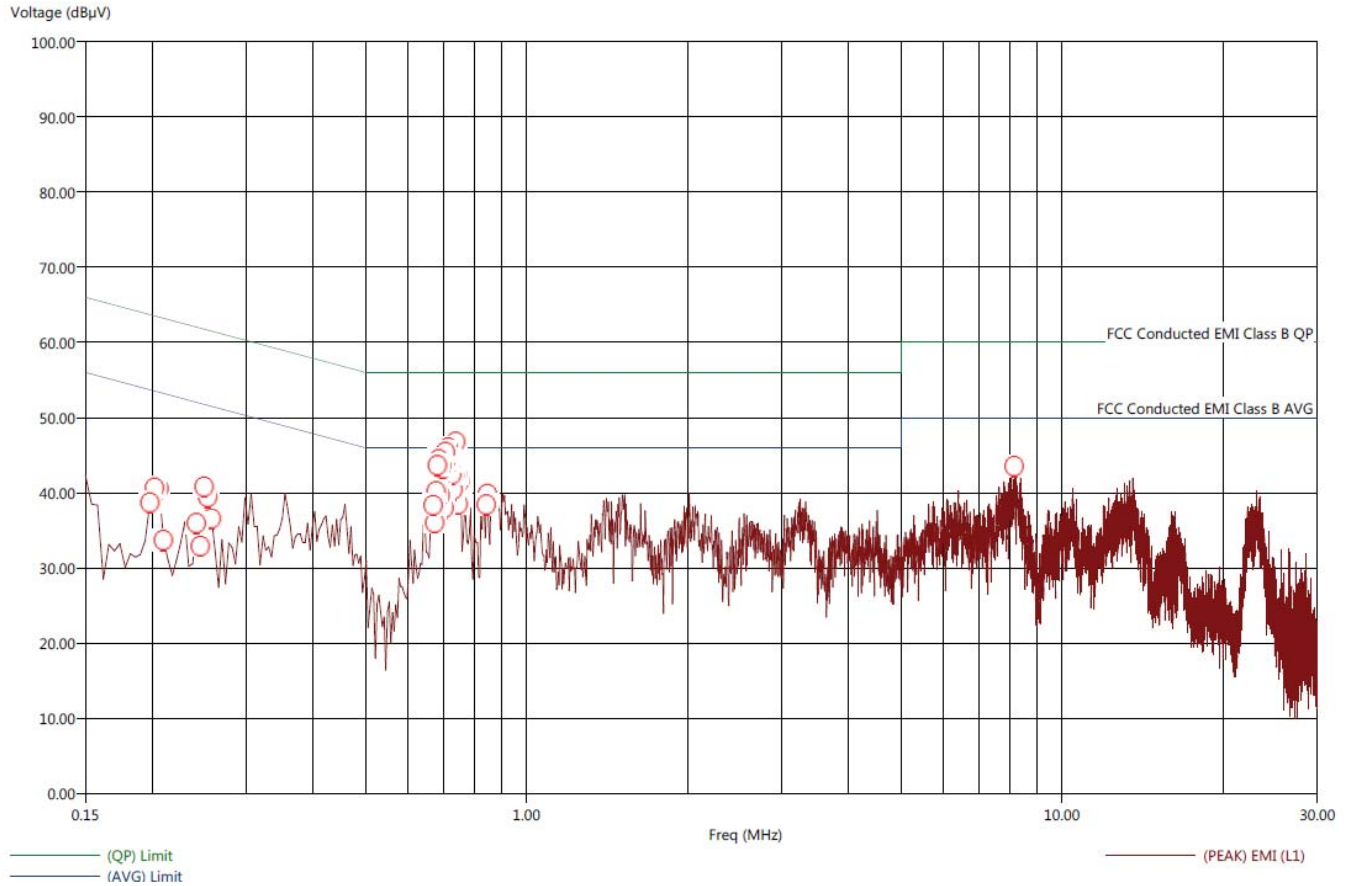

Title: FCC Class B - Conducted Emissions - Black Lead  
 File: Agilent - Conducted - Final Test - Line - PULSE - VPx Access Point - Tx Mode - FCC Class B.set  
 Operator: Kyle Fujimoto  
 EUT Type: VPx Access Point  
 EUT Condition: The EUT was continuously frequency hopping  
 Comments: Company: Mesa Labs, Inc.  
 Model: CM-000250  
 With PULSE Antenna

7/27/2016 11:08:12 AM  
 Sequence: Final Measurements

FCC Class B - Conducted Emissions - Black Lead

Freq (MHz)	(PEAK) EMI (dBµV)	(AVG) EMI (dBµV)	(PEAK) Margin AVL (dB)	(AVG) Margin AVL (dB)	(AVG) Limit (dBµV)	Cable (dB)	Transducer (dB)	Filter (dB)
0.198	50.26	36.94	-3.49	-16.81	53.75	0.08	0.36	9.83
0.202	50.88	40.10	-2.69	-13.47	53.57	0.08	0.35	9.83
0.206	51.05	40.07	-2.49	-13.47	53.54	0.08	0.35	9.83
0.210	50.85	39.16	-2.61	-14.30	53.46	0.08	0.34	9.83
0.242	45.97	31.86	-6.00	-20.11	51.98	0.08	0.24	9.83
0.246	46.47	34.78	-5.11	-16.80	51.57	0.08	0.22	9.83
0.250	46.96	36.61	-4.76	-15.11	51.72	0.08	0.22	9.83
0.254	46.56	35.66	-5.23	-16.13	51.79	0.08	0.23	9.83
0.258	45.50	32.46	-5.97	-19.01	51.48	0.08	0.21	9.83
0.670	46.09	37.87	0.09	-8.13	46.00	0.09	0.04	9.84
0.674	46.34	38.10	0.34	-7.90	46.00	0.09	0.04	9.84
0.678	46.94	38.74	0.94	-7.26	46.00	0.09	0.04	9.84
0.682	49.13	41.58	3.13	-4.42	46.00	0.10	0.04	9.84
0.686	48.60	39.53	2.60	-6.47	46.00	0.09	0.04	9.84
0.690	47.49	39.05	1.49	-6.95	46.00	0.09	0.04	9.84
0.694	49.10	41.29	3.10	-4.71	46.00	0.10	0.04	9.84
0.698	48.63	40.10	2.63	-5.90	46.00	0.10	0.04	9.84
0.702	47.95	39.71	1.95	-6.29	46.00	0.10	0.04	9.84
0.706	48.74	40.80	2.74	-5.20	46.00	0.10	0.04	9.84
0.710	48.59	41.34	2.59	-4.66	46.00	0.10	0.04	9.84
0.714	48.53	40.30	2.53	-5.70	46.00	0.10	0.04	9.84
0.718	48.98	41.69	2.98	-4.31	46.00	0.10	0.04	9.84
0.722	49.28	41.03	3.28	-4.97	46.00	0.10	0.04	9.84
0.726	49.24	41.24	3.24	-4.76	46.00	0.10	0.04	9.84
0.730	48.79	41.36	2.79	-4.64	46.00	0.10	0.04	9.84
0.734	49.27	40.70	3.27	-5.30	46.00	0.10	0.04	9.84
0.738	49.09	41.50	3.09	-4.50	46.00	0.10	0.04	9.84
0.742	48.59	41.08	2.59	-4.92	46.00	0.10	0.04	9.84
0.746	48.76	41.30	2.76	-4.70	46.00	0.10	0.04	9.84
0.750	48.99	41.10	2.99	-4.90	46.00	0.10	0.04	9.84
0.754	49.12	40.96	3.12	-5.04	46.00	0.10	0.04	9.84
0.842	42.88	34.47	-3.12	-11.53	46.00	0.10	0.04	9.84
0.846	43.33	34.64	-2.67	-11.36	46.00	0.10	0.04	9.84
8.154	44.79	35.36	-5.21	-14.64	50.00	0.33	0.03	10.02



Title: FCC Class B - Conducted Emissions - White Lead  
 File: Agilent - Conducted - Pre-Test - Neutral - PULSE - VPx Access Point - Tx Mode - FCC Class B.set  
 Operator: Kyle Fujimoto  
 EUT Type: VPx Access Point  
 EUT Condition: The EUT was continuously frequency hopping  
 Comments: Company: Mesa Labs, Inc.  
 Model: CM-000250  
 With PULSE Antenna

7/27/2016 11:12:07 AM  
 Sequence: Preliminary Scan

FCC Class B - Conducted Emissions - White Lead

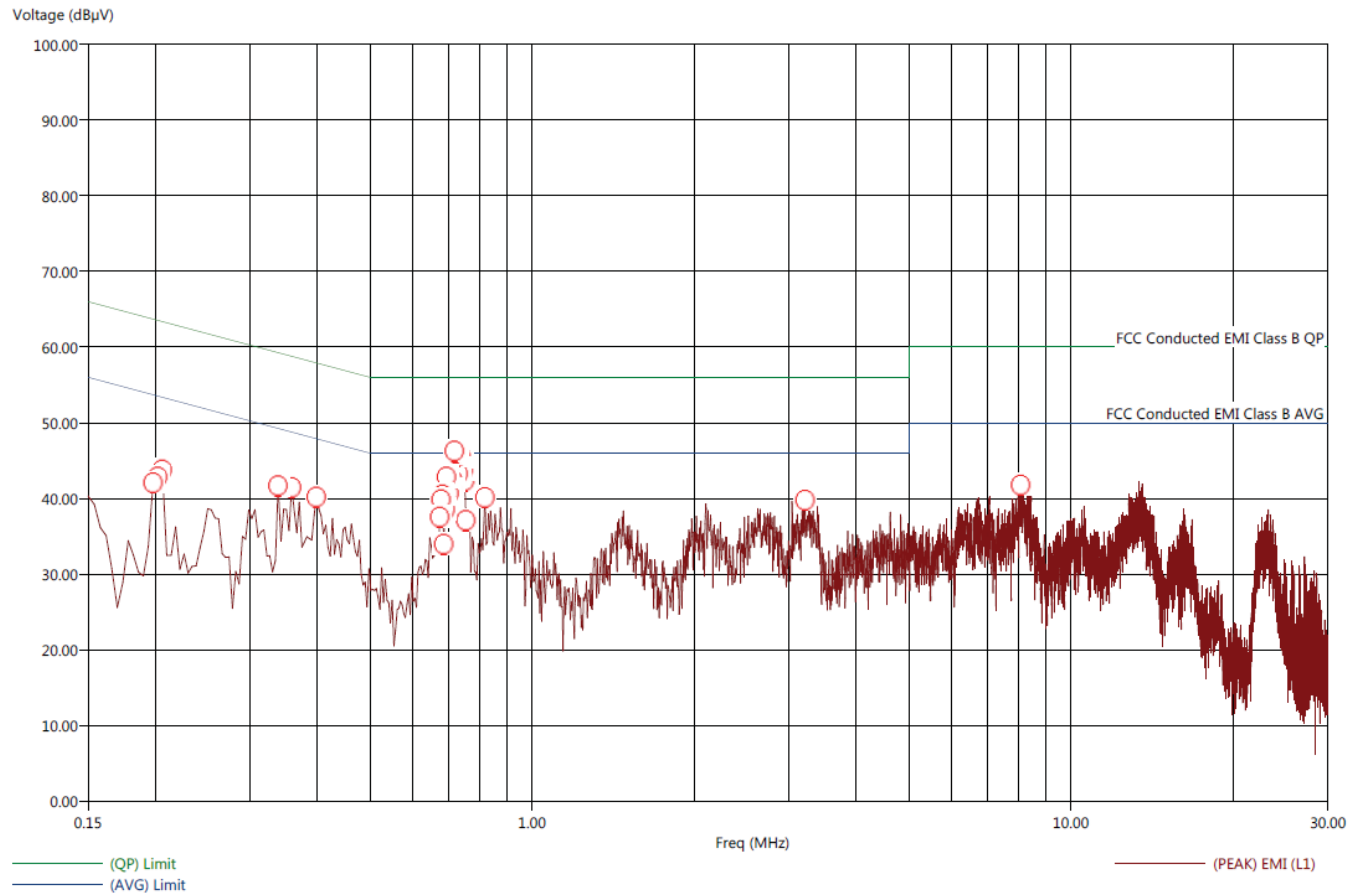



Title: FCC Class B - Conducted Emissions - White Lead  
 File: Agilent - Conducted - Final Test - Neutral - L-COM - VPx Access Point - Tx Mode - FCC Class B.set  
 Operator: Kyle Fujimoto  
 EUT Type: VPx Access Point  
 EUT Condition: The EUT was continuously frequency hopping  
 Comments: Company: Mesa Labs, Inc.  
 Model: CM-000250  
 With PULSE Antenna

7/27/2016 11:14:49 AM  
 Sequence: Final Measurements

FCC Class B - Conducted Emissions - White Lead

Freq (MHz)	(PEAK) EMI (dBµV)	(AVG) EMI (dBµV)	(PEAK) Margin AVL (dB)	(AVG) Margin AVL (dB)	(AVG) Limit (dBµV)	Cable (dB)	Transducer (dB)	Filter (dB)
0.198	52.28	38.09	-1.51	-15.70	53.79	0.08	0.35	9.83
0.202	52.52	42.43	-1.03	-11.12	53.54	0.08	0.34	9.83
0.206	52.38	41.31	-1.07	-12.14	53.45	0.08	0.33	9.83
0.338	43.99	33.56	-5.06	-15.49	49.05	0.08	0.04	9.84
0.358	44.07	35.04	-4.86	-13.89	48.93	0.08	0.03	9.84
0.398	42.93	33.91	-4.98	-14.00	47.91	0.08	0.04	9.84
0.674	48.36	39.94	2.36	-6.06	46.00	0.10	0.03	9.84
0.678	46.17	37.67	0.17	-8.33	46.00	0.09	0.03	9.84
0.682	48.02	39.61	2.02	-6.39	46.00	0.10	0.03	9.84
0.686	49.04	40.57	3.04	-5.43	46.00	0.10	0.03	9.84
0.690	47.80	39.12	1.80	-6.88	46.00	0.09	0.03	9.84
0.694	48.00	39.87	2.00	-6.13	46.00	0.10	0.03	9.84
0.698	48.29	39.32	2.29	-6.68	46.00	0.09	0.03	9.84
0.702	48.79	41.33	2.79	-4.67	46.00	0.10	0.03	9.84
0.706	49.23	41.64	3.23	-4.36	46.00	0.10	0.03	9.84
0.710	48.62	41.55	2.62	-4.45	46.00	0.10	0.03	9.84
0.714	49.08	41.65	3.08	-4.35	46.00	0.10	0.03	9.84
0.718	49.36	41.64	3.36	-4.36	46.00	0.10	0.03	9.84
0.722	47.97	39.30	1.97	-6.70	46.00	0.09	0.03	9.84
0.726	48.77	41.61	2.77	-4.39	46.00	0.10	0.03	9.84
0.730	49.37	41.19	3.37	-4.81	46.00	0.10	0.03	9.84
0.734	49.19	41.25	3.19	-4.75	46.00	0.10	0.03	9.84
0.738	48.66	40.88	2.66	-5.12	46.00	0.10	0.03	9.84
0.742	48.84	41.55	2.84	-4.45	46.00	0.10	0.03	9.84
0.746	48.17	40.10	2.17	-5.90	46.00	0.10	0.03	9.84
0.750	45.26	36.66	-0.74	-9.34	46.00	0.10	0.03	9.84
0.754	48.20	40.23	2.20	-5.77	46.00	0.10	0.03	9.84
0.818	41.62	32.80	-4.38	-13.20	46.00	0.10	0.03	9.84
3.214	41.39	32.38	-4.61	-13.62	46.00	0.20	0.04	9.89
8.074	45.00	34.96	-5.00	-15.04	50.00	0.33	0.03	10.02

Title: FCC Class B - Conducted Emissions - Black Lead  
 File: Aqilent - Conducted - Pre-Test - Line - PULSE - VPx Access Point - Rx Mode - FCC Class B.set  
 Operator: Kyle Fujimoto  
 EUT Type: VPx Access Point  
 EUT Condition: The EUT was continuously receiving  
 Comments: Company: Mesa Labs, Inc.  
 Model: CM-000250  
 With PULSE Antenna

7/27/2016 11:23:38 AM  
 Sequence: Preliminary Scan

FCC Class B - Conducted Emissions - Black Lead

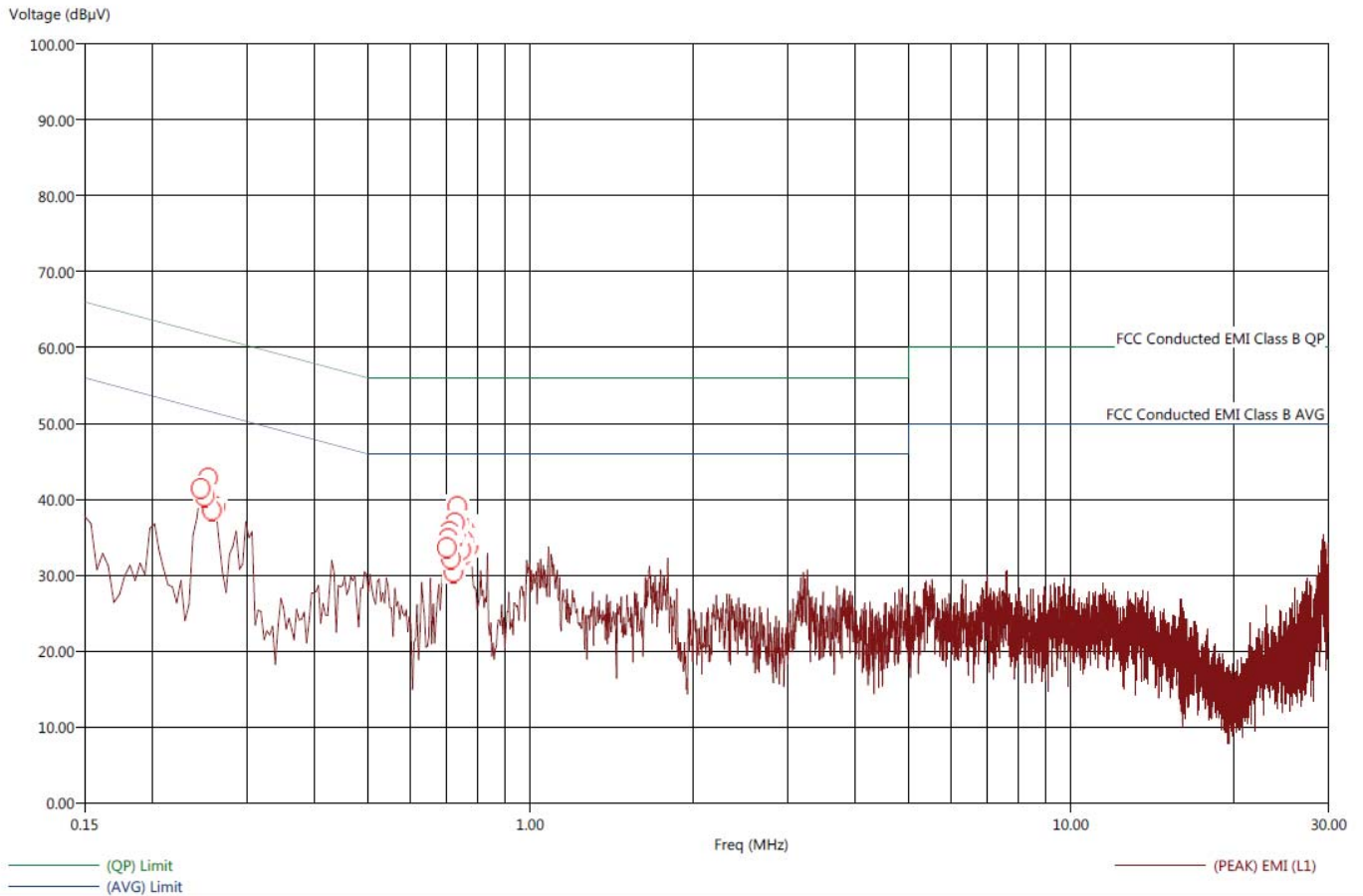

Title: FCC Class B - Conducted Emissions - Black Lead  
 File: Agilent - Conducted - Final Test - Line - PULSE - VPx Access Point - Rx Mode - FCC Class B.set  
 Operator: Kyle Fujimoto  
 EUT Type: VPx Access Point  
 EUT Condition: The EUT was continuously receiving  
 Comments: Company: Mesa Labs, Inc.  
 Model: CM-000250  
 With PULSE Antenna

7/27/2016 11:25:02 AM  
 Sequence: Final Measurements

**FCC Class B - Conducted Emissions - Black Lead**

Freq (MHz)	(PEAK) EMI (dBµV)	(AVG) EMI (dBµV)	(PEAK) Margin AVL (dB)	(AVG) Margin AVL (dB)	(AVG) Limit (dBµV)	Cable (dB)	Transducer (dB)	Filter (dB)
0.246	43.89	27.86	-7.90	-23.93	51.80	0.08	0.23	9.83
0.250	43.87	26.75	-7.98	-25.10	51.85	0.08	0.23	9.83
0.254	44.22	28.59	-7.54	-23.17	51.76	0.08	0.23	9.83
0.258	44.28	29.69	-7.43	-22.02	51.70	0.08	0.22	9.83
0.262	43.64	27.71	-7.94	-23.87	51.58	0.08	0.22	9.83
0.702	41.17	31.45	-4.83	-14.55	46.00	0.10	0.04	9.84
0.706	40.81	30.83	-5.19	-15.17	46.00	0.10	0.04	9.84
0.710	40.87	31.48	-5.13	-14.52	46.00	0.10	0.04	9.84
0.714	40.96	31.52	-5.04	-14.48	46.00	0.10	0.04	9.84
0.718	40.92	31.51	-5.08	-14.49	46.00	0.10	0.04	9.84
0.722	40.67	30.22	-5.33	-15.78	46.00	0.10	0.04	9.84
0.726	40.22	29.69	-5.78	-16.31	46.00	0.10	0.04	9.84
0.730	40.56	30.42	-5.44	-15.58	46.00	0.10	0.04	9.84
0.734	41.20	31.31	-4.80	-14.69	46.00	0.10	0.04	9.84
0.738	40.44	30.16	-5.56	-15.84	46.00	0.10	0.04	9.84
0.742	41.01	31.38	-4.99	-14.62	46.00	0.10	0.04	9.84
0.746	40.73	30.55	-5.27	-15.45	46.00	0.10	0.04	9.84
0.750	41.02	31.04	-4.98	-14.96	46.00	0.10	0.04	9.84
0.754	40.41	29.16	-5.59	-16.84	46.00	0.10	0.04	9.84
0.758	41.22	31.11	-4.78	-14.89	46.00	0.10	0.04	9.84
0.762	40.94	31.26	-5.06	-14.74	46.00	0.10	0.04	9.84
0.766	40.53	29.38	-5.47	-16.62	46.00	0.10	0.04	9.84
0.770	41.11	30.30	-4.89	-15.70	46.00	0.10	0.04	9.84
0.774	39.74	28.80	-6.26	-17.20	46.00	0.10	0.04	9.84
0.778	40.85	30.77	-5.15	-15.23	46.00	0.10	0.04	9.84



Title: FCC Class B - Conducted Emissions - White Lead  
 File: Agilent - Conducted - Pre-Test - Neutral - PULSE - VPx Access Point - Rx Mode - FCC Class B.set  
 Operator: Kyle Fujimoto  
 EUT Type: VPx Access Point  
 EUT Condition: The EUT was continuously receiving  
 Comments: Company: Mesa Labs, Inc.  
 Model: CM-000250  
 With PULSE Antenna

7/27/2016 11:28:15 AM  
 Sequence: Preliminary Scan

FCC Class B - Conducted Emissions - White Lead

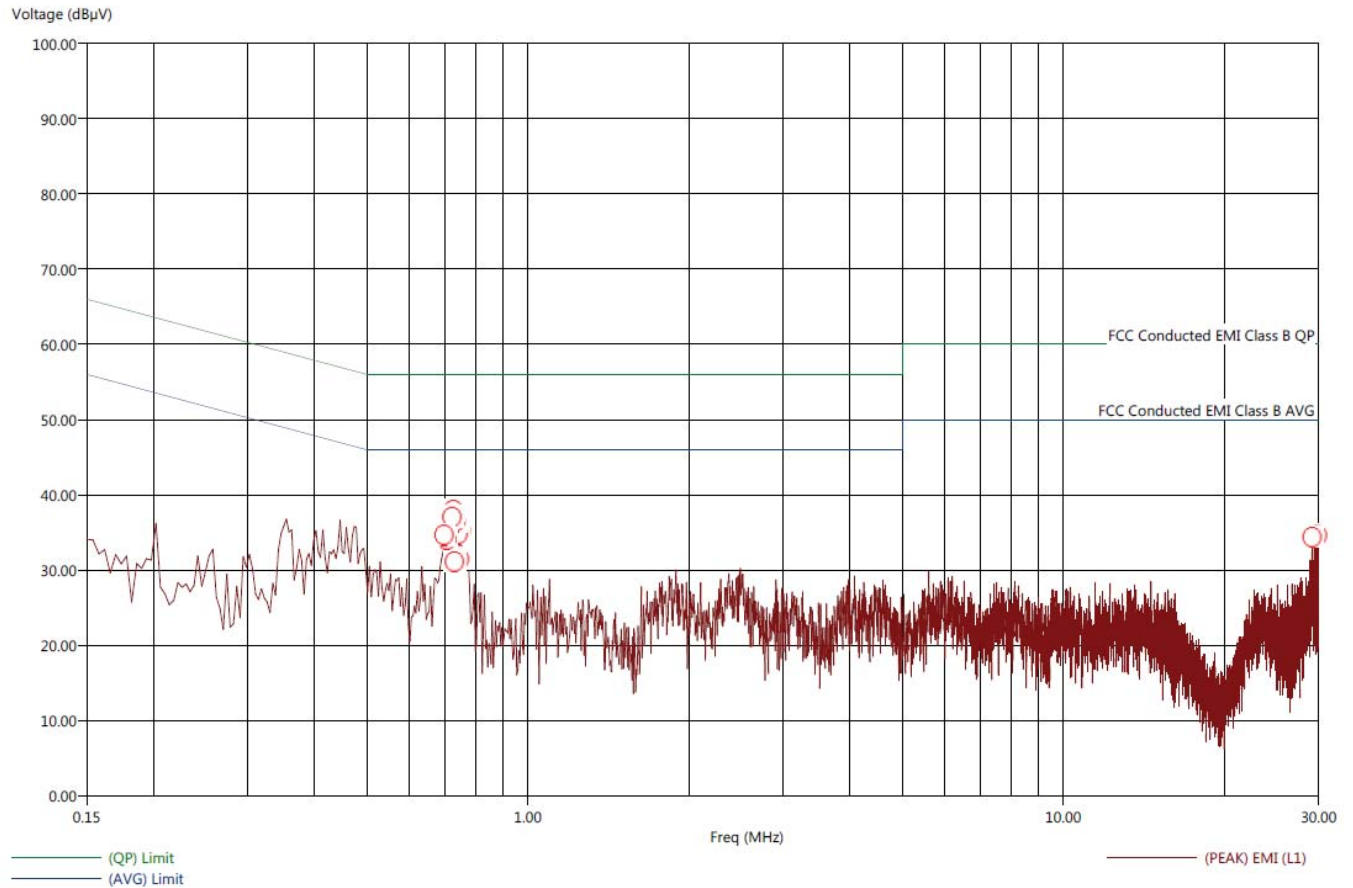

Title: FCC Class B - Conducted Emissions - White Lead  
 File: Agilent - Conducted - Final Test - Neutral - PULSE - VPx Access Point - Rx Mode - FCC Class B.set  
 Operator: Kyle Fujimoto  
 EUT Type: VPx Access Point  
 EUT Condition: The EUT was continuously receiving  
 Comments: Company: Mesa Labs, Inc.  
 Model:CM-000250  
 With PULSE Antenna

7/27/2016 11:30:16 AM  
 Sequence: Final Measurements

## FCC Class B - Conducted Emissions - White Lead

Freq (MHz)	(PEAK) EMI (dBµV)	(AVG) EMI (dBµV)	(PEAK) Margin AVL (dB)	(AVG) Margin AVL (dB)	(AVG) Limit (dBµV)	Cable (dB)	Transducer (dB)	Filter (dB)
0.698	41.21	33.55	-4.79	-12.45	46.00	0.10	0.03	9.84
0.706	40.09	31.60	-5.91	-14.40	46.00	0.10	0.03	9.84
0.722	40.35	32.05	-5.65	-13.95	46.00	0.10	0.03	9.84
0.726	41.12	33.32	-4.88	-12.68	46.00	0.10	0.03	9.84
0.730	40.86	33.31	-5.14	-12.69	46.00	0.10	0.03	9.84
0.734	40.77	33.80	-5.23	-12.20	46.00	0.10	0.03	9.84
0.742	40.76	32.57	-5.24	-13.43	46.00	0.10	0.03	9.84
0.746	41.26	33.25	-4.74	-12.75	46.00	0.10	0.03	9.84
0.750	40.04	31.56	-5.96	-14.44	46.00	0.10	0.03	9.84
29.178	37.72	23.81	-12.28	-26.19	50.00	0.73	0.12	10.68
29.862	37.55	24.08	-12.45	-25.92	50.00	0.74	0.12	10.68



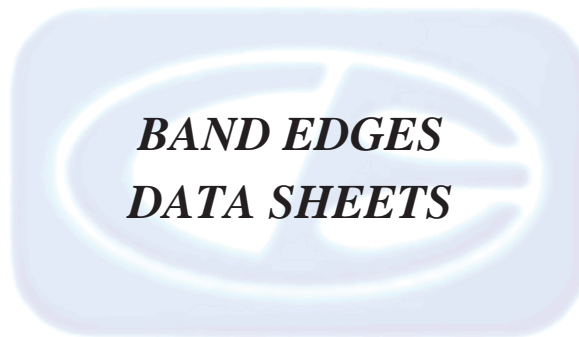

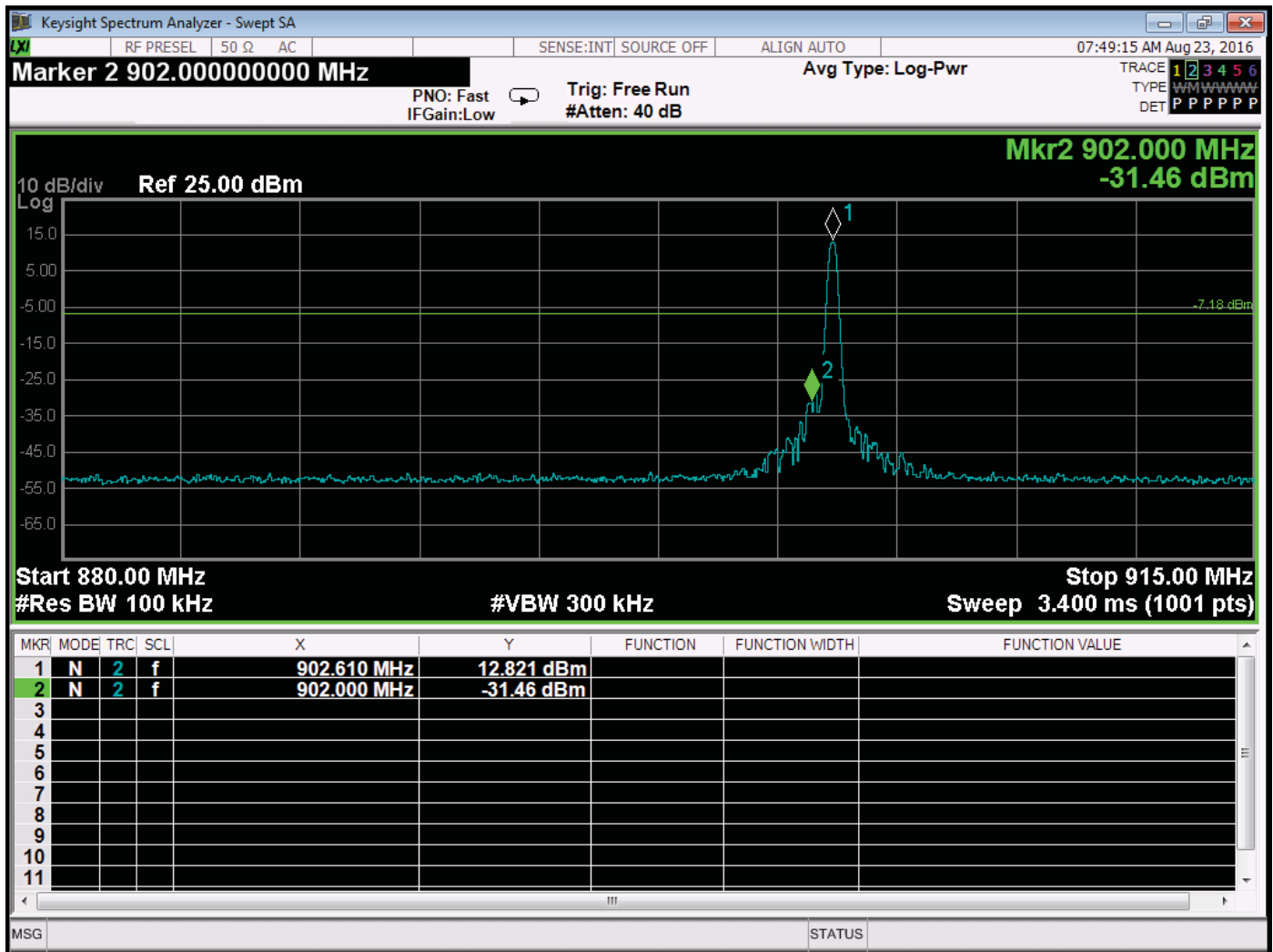

Band Edge – Low Channel – Fixed Frequency Mode

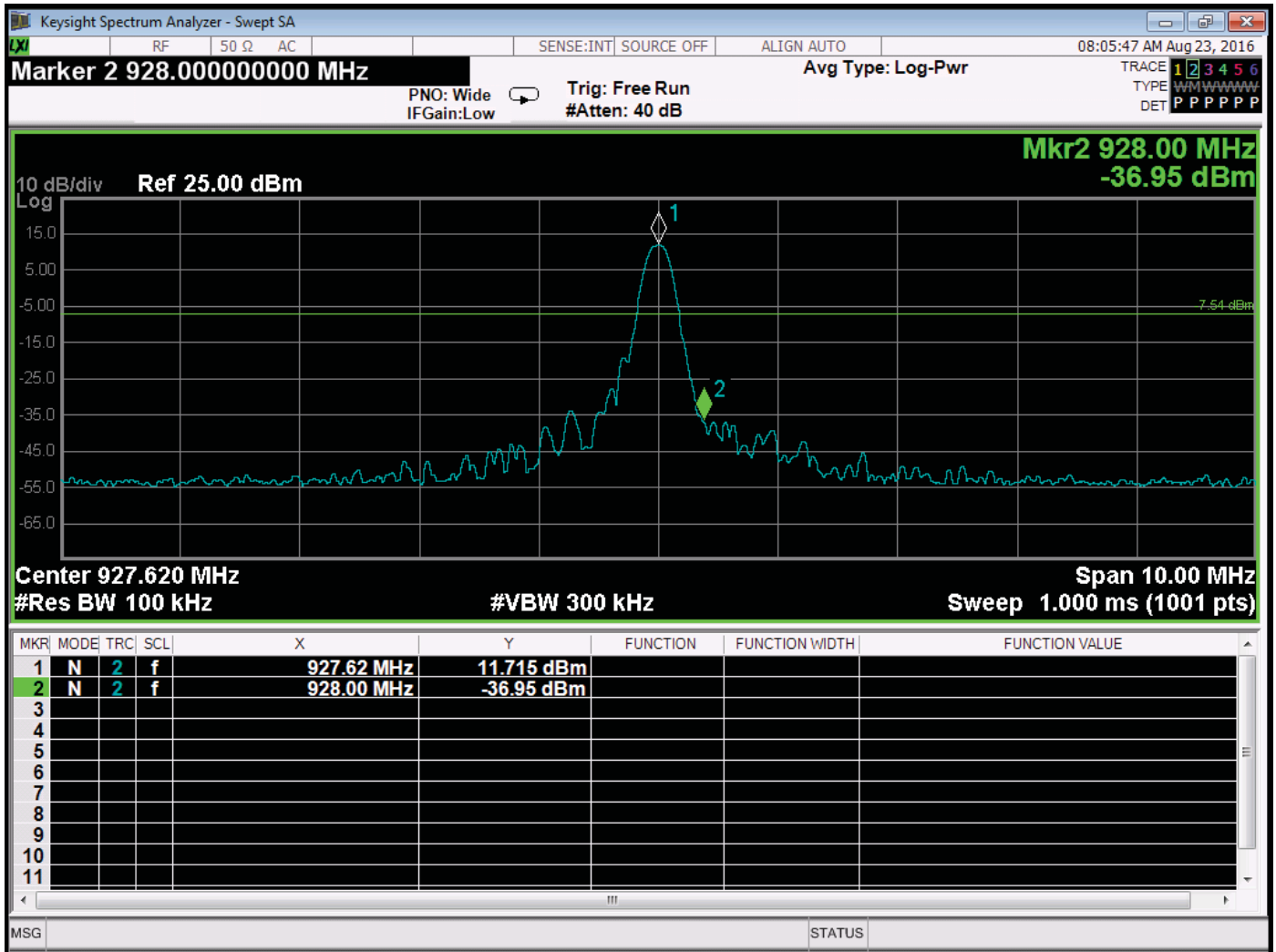

Band Edge – High Channel – Fixed Frequency Mode



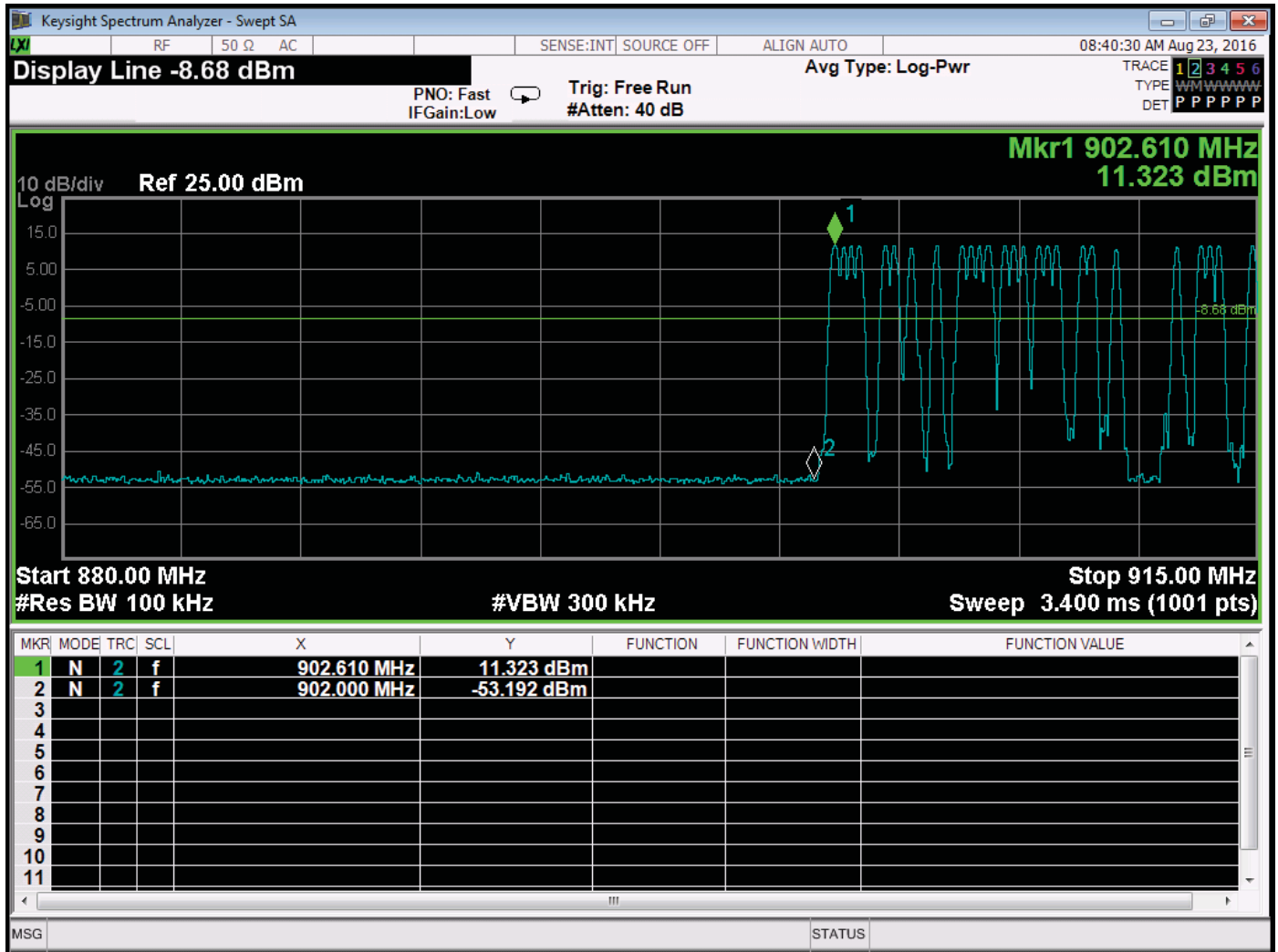

Band Edge – Low Channel – Frequency Hopping Mode

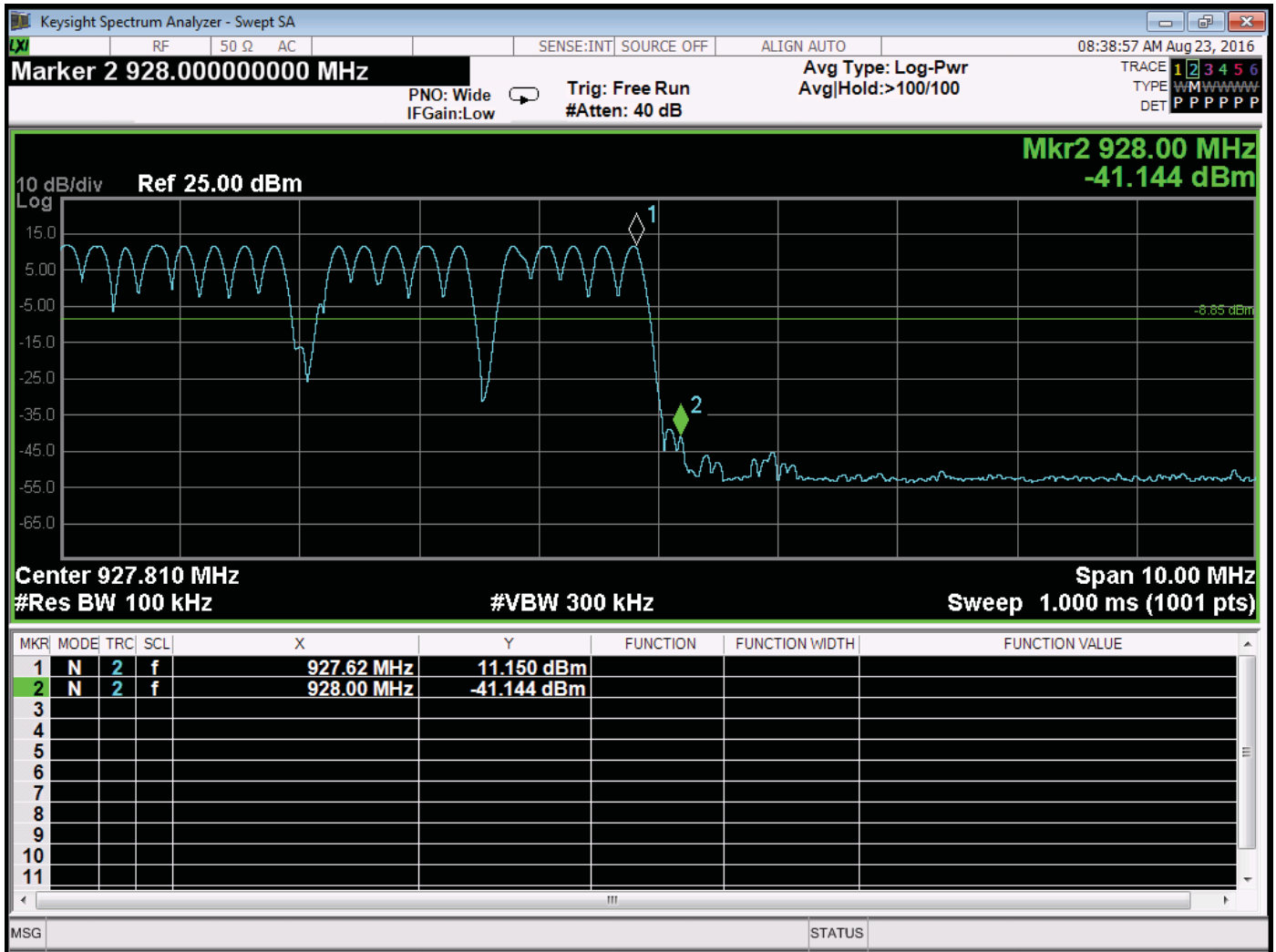

Band Edge – High Channel – Frequency Hopping Mode



***-20 DB BANDWIDTH  
DATA SHEETS***





-20 dB Bandwidth – Middle Channel



-20 dB Bandwidth – High Channel



***RF ANTENNA CONDUCTED  
DATA SHEETS***

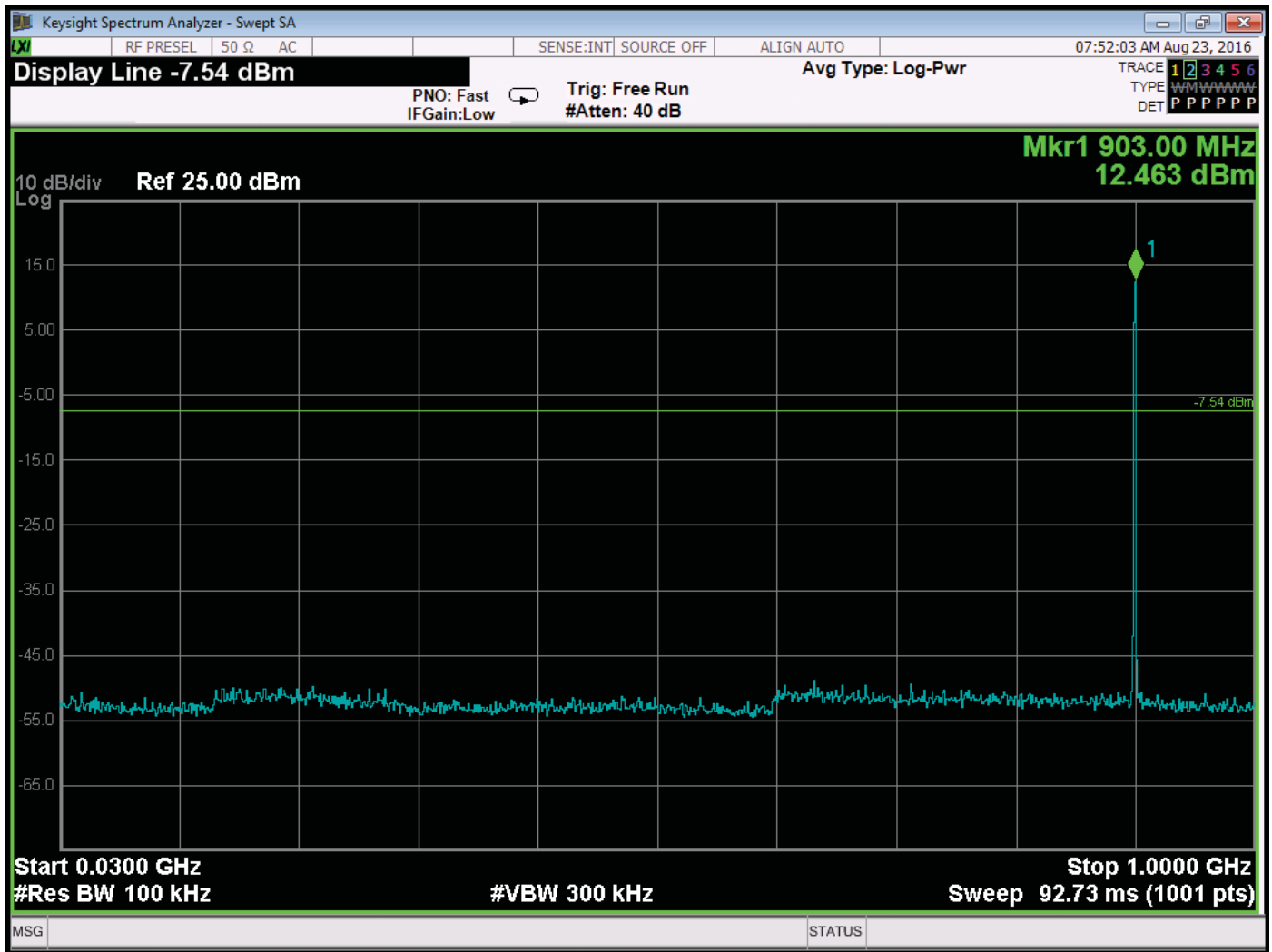

RF Antenna Conducted – Low Channel – 30 MHz to 1 GHz



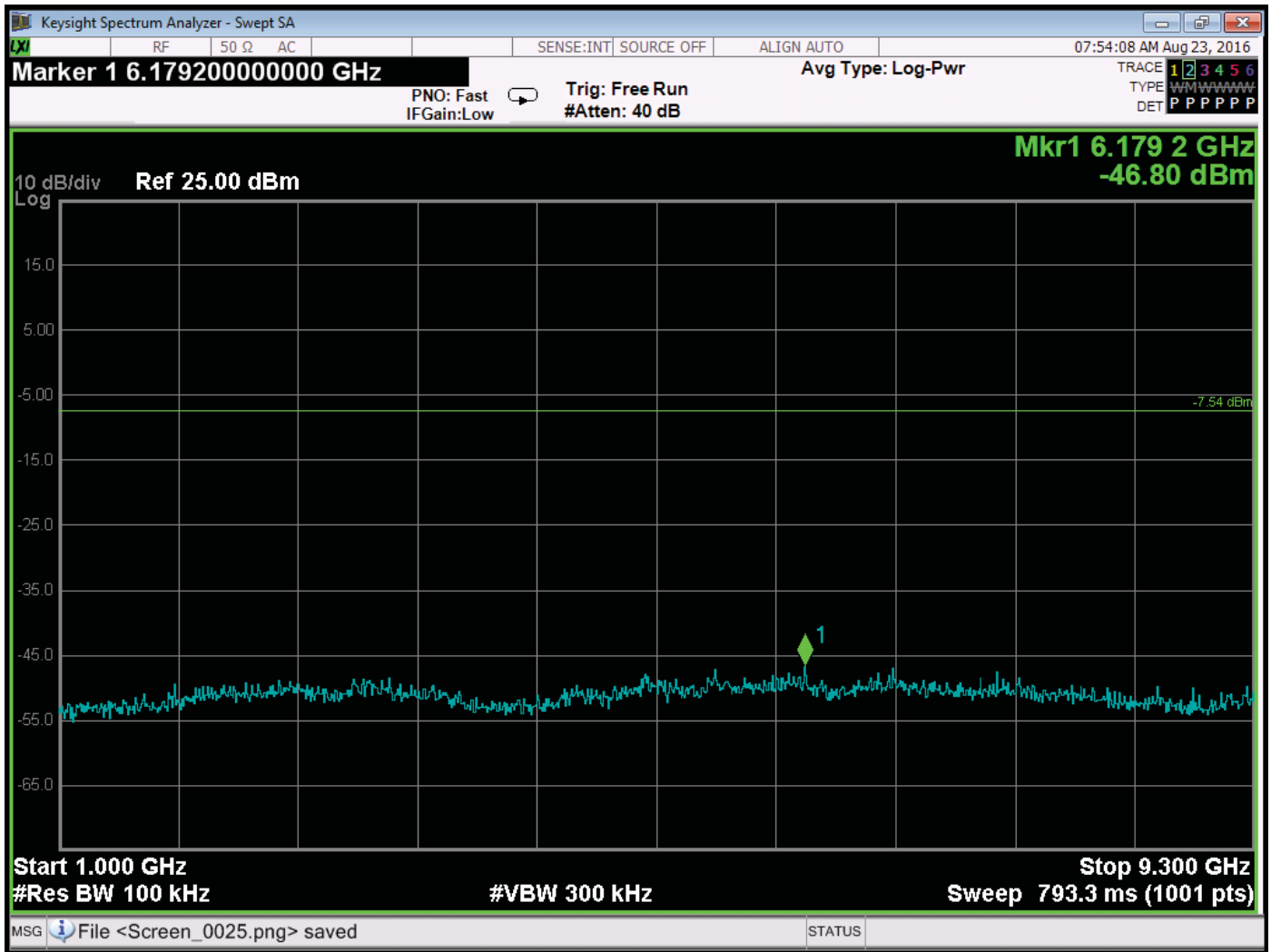

RF Antenna Conducted – Low Channel – 1 GHz to 9.3 GHz

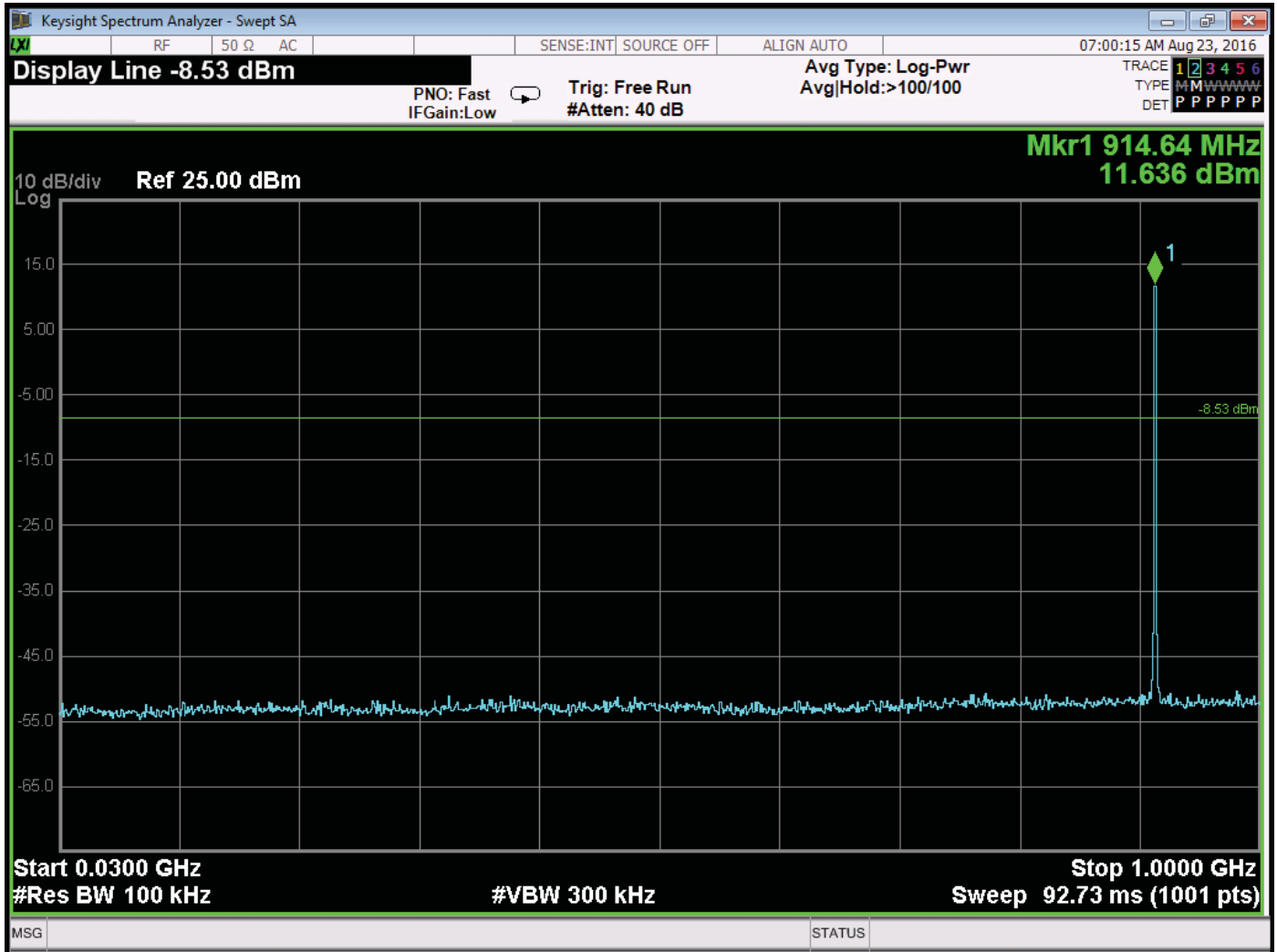

RF Antenna Conducted – Middle Channel – 30 MHz to 1 GHz



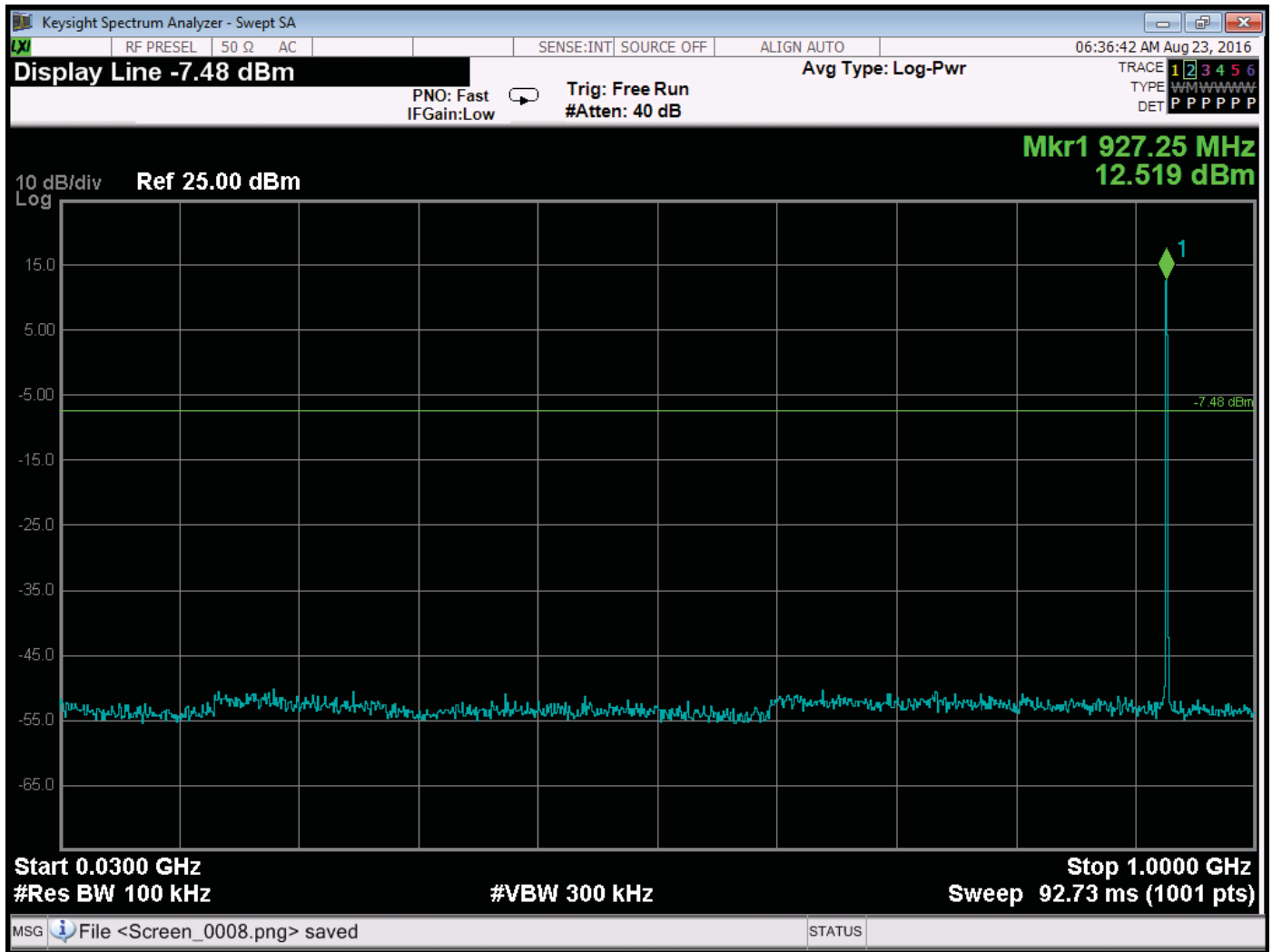

RF Antenna Conducted – High Channel – 30 MHz to 1 GHz

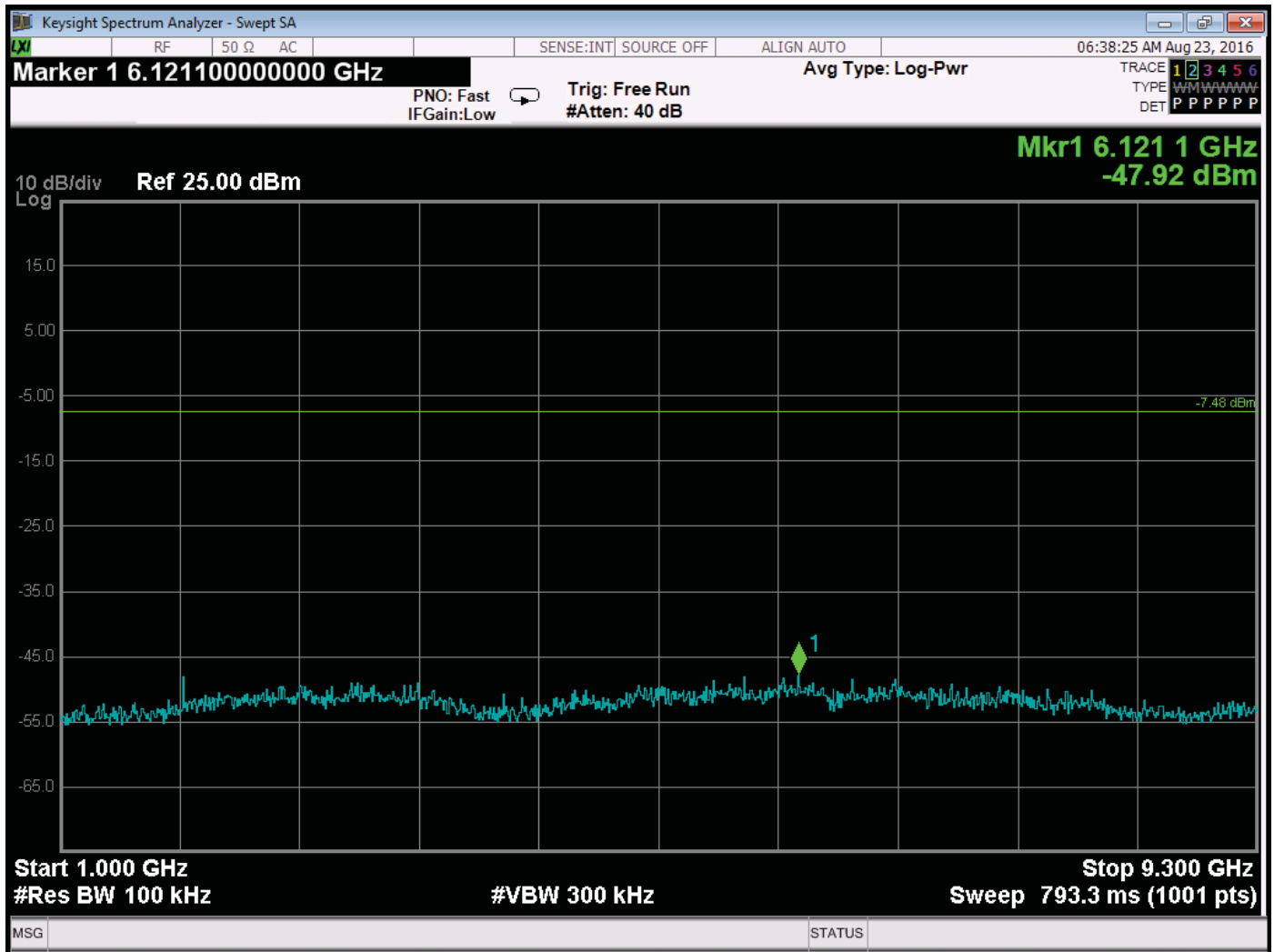

RF Antenna Conducted – High Channel – 1 GHz to 9.3 GHz

***PEAK POWER OUTPUT  
DATA SHEETS***

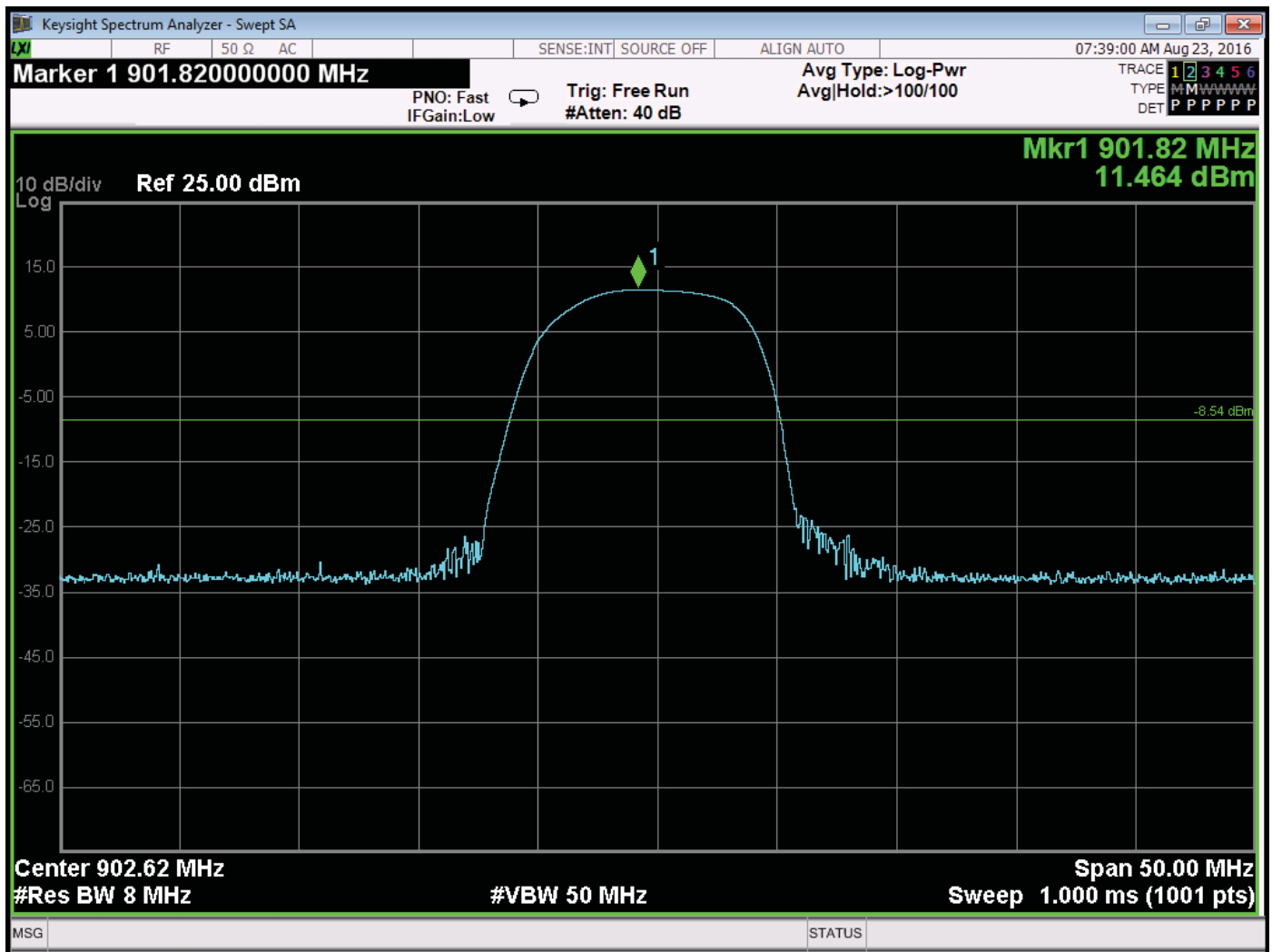

Peak Power Output – Low Channel

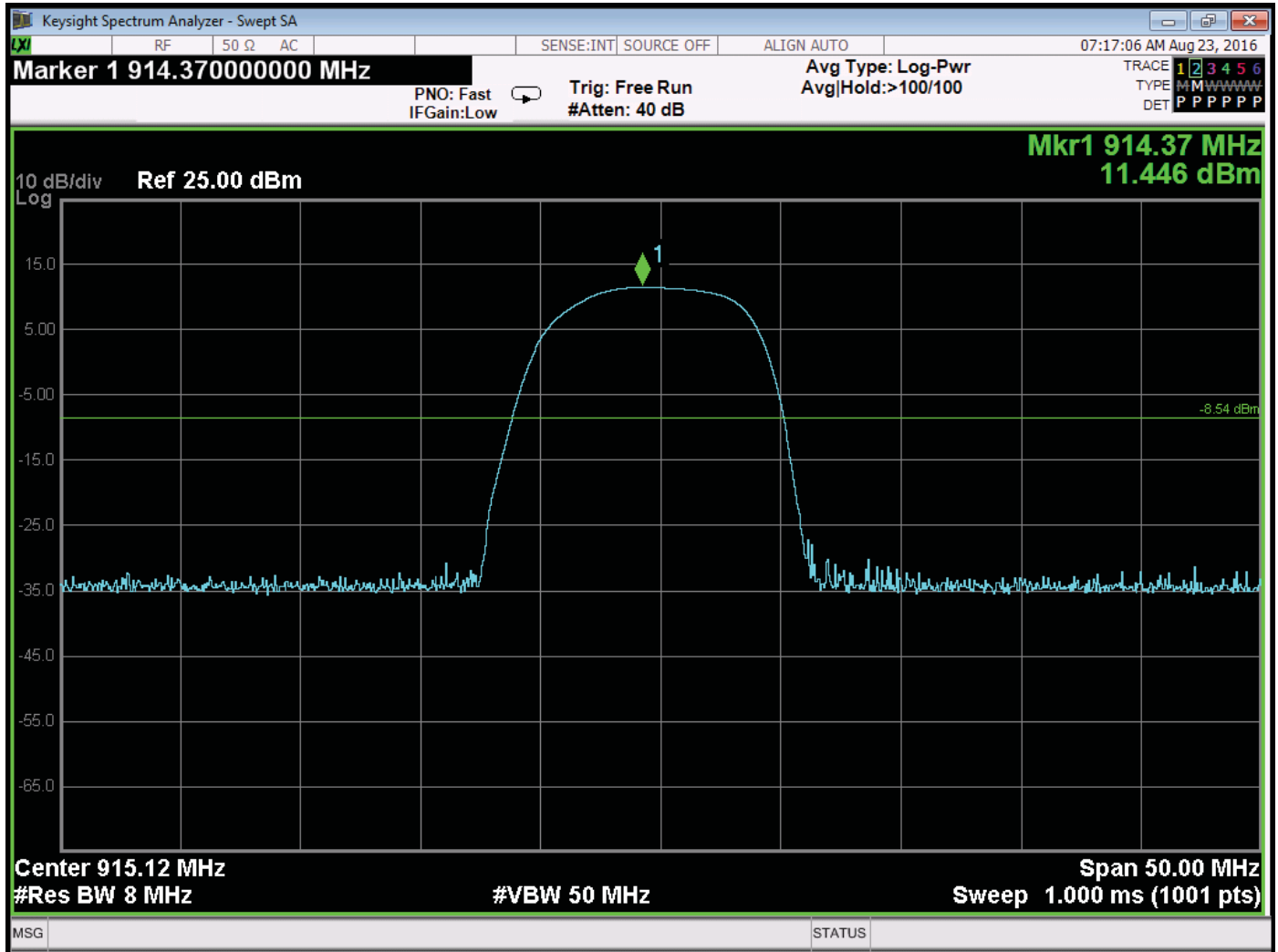

Peak Power Output – Middle Channel



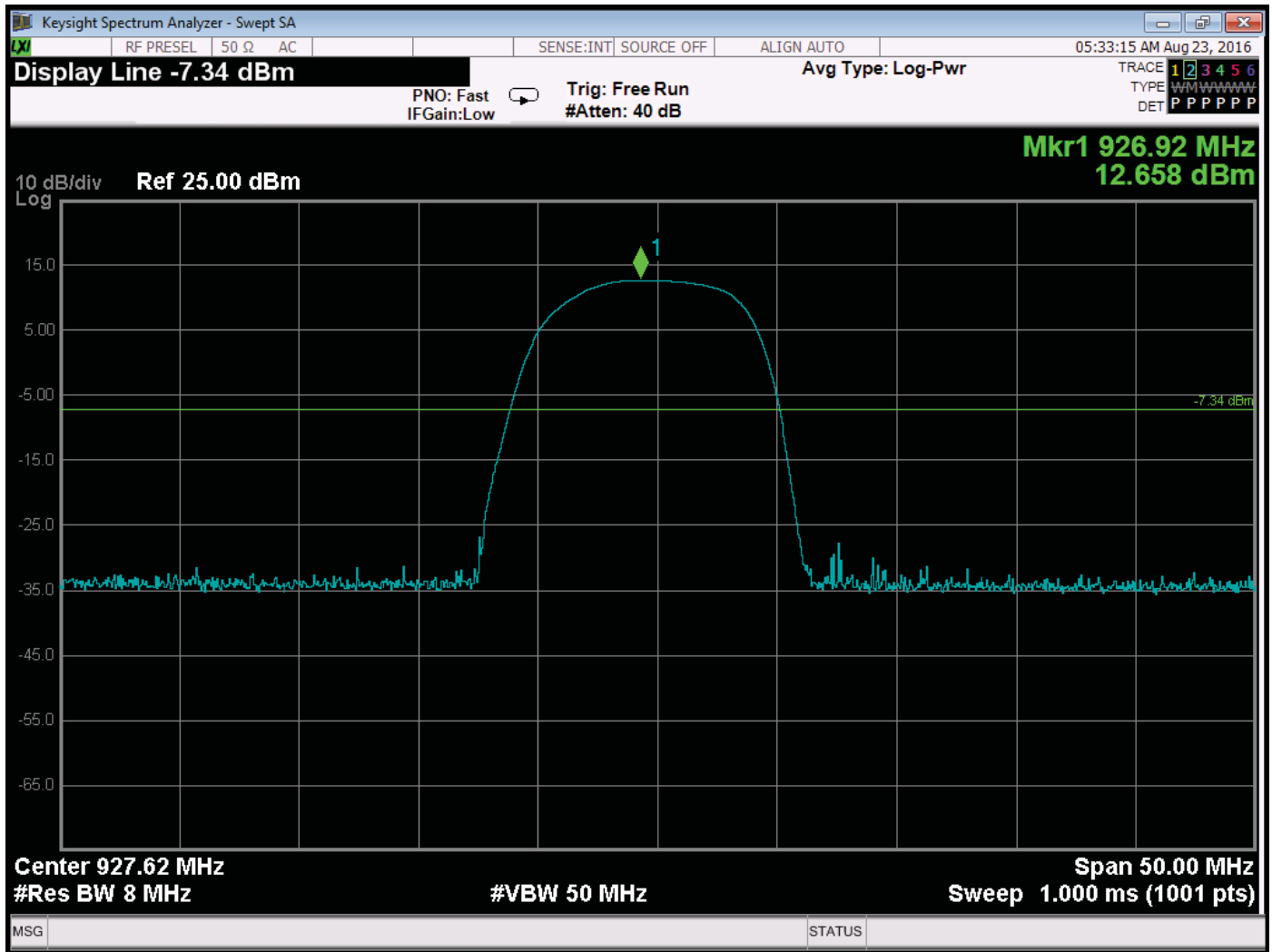

Peak Power Output – High Channel



***CHANNEL FREQUENCY SEPARATION  
DATA SHEET***

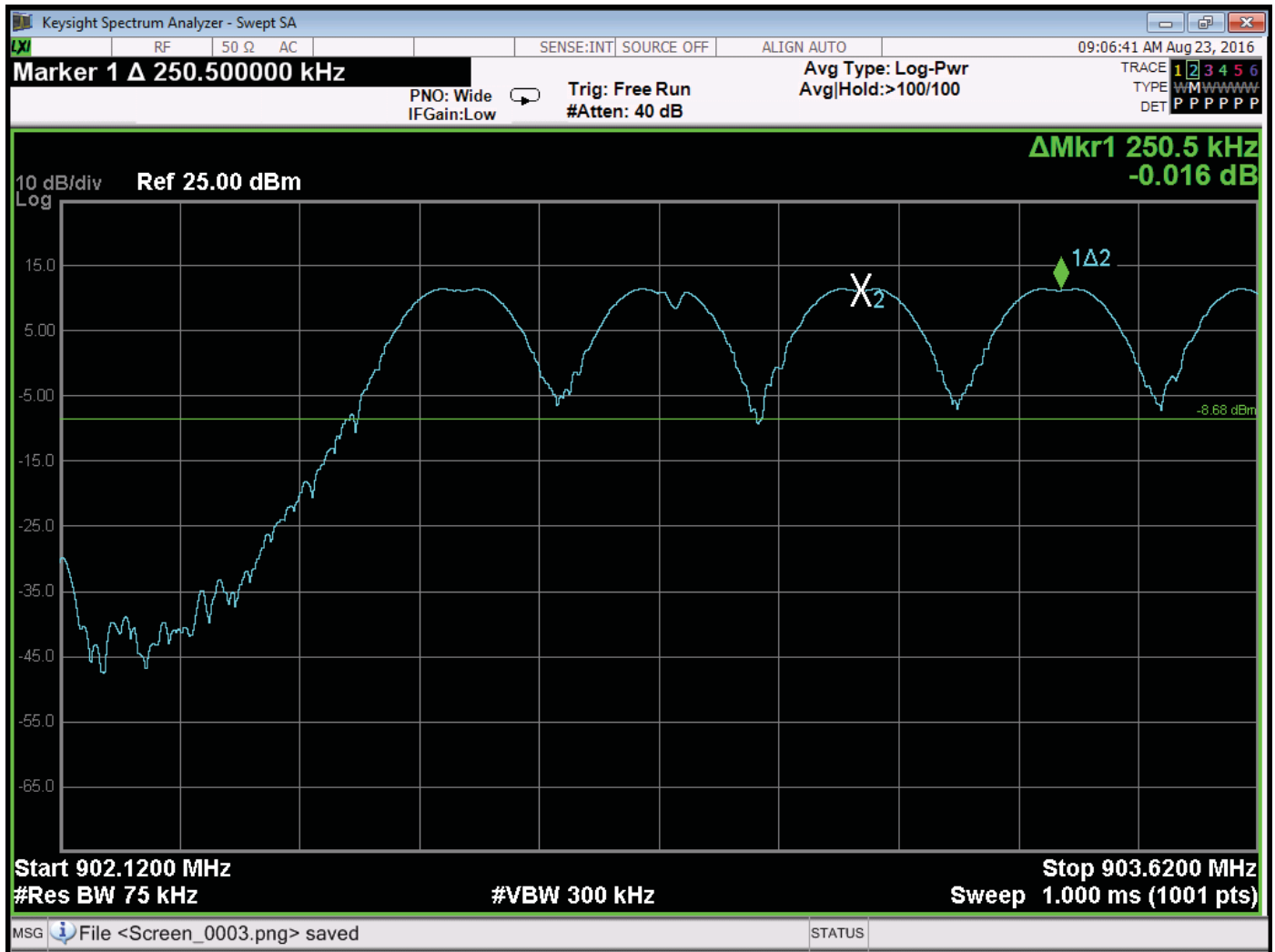

Channel Frequency Separation



***NUMBER OF FREQUENCIES***

***DATA SHEET***

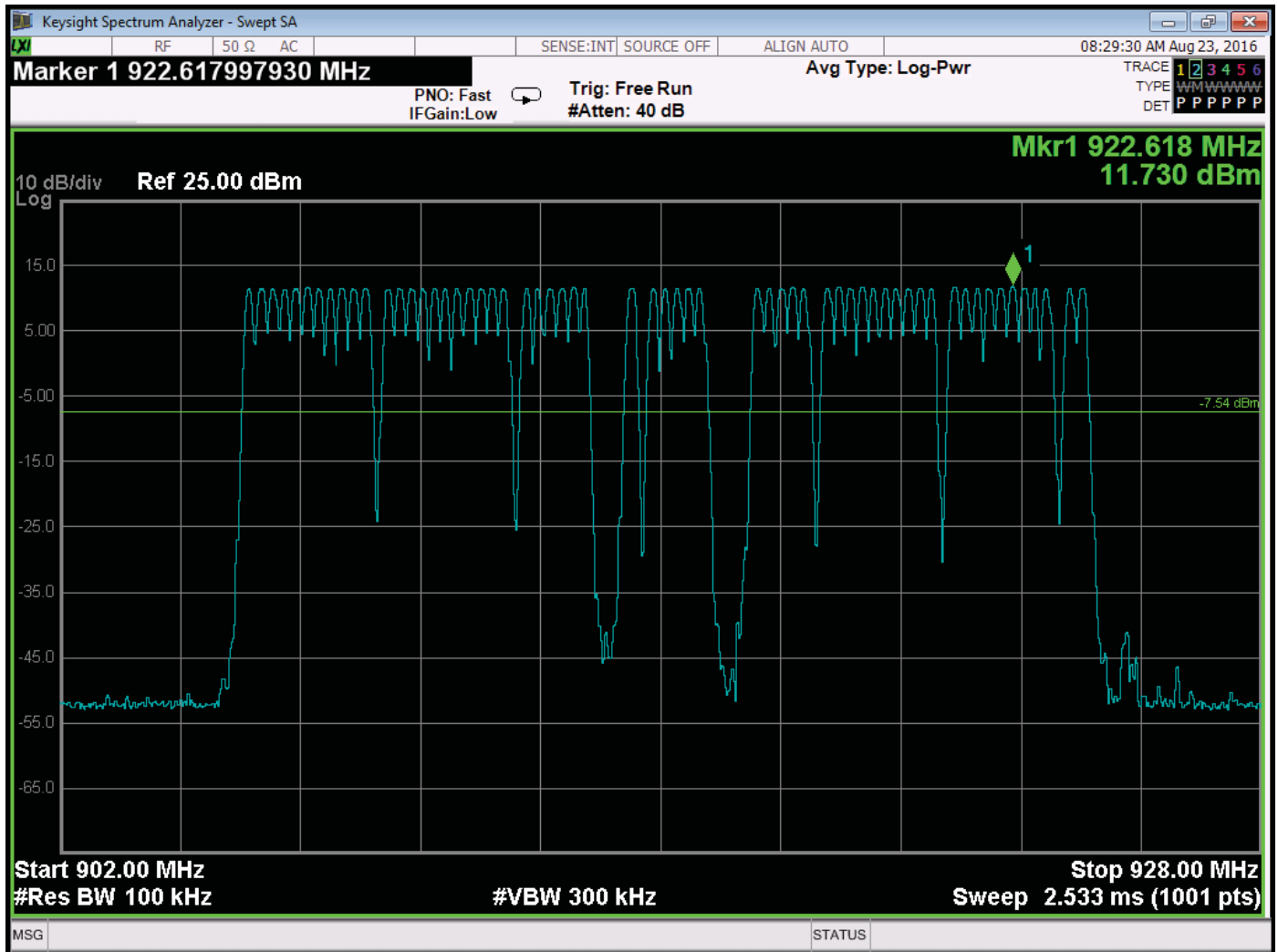

Number of Channels is 60 – 906.12 MHz to 924.12 MHz Band

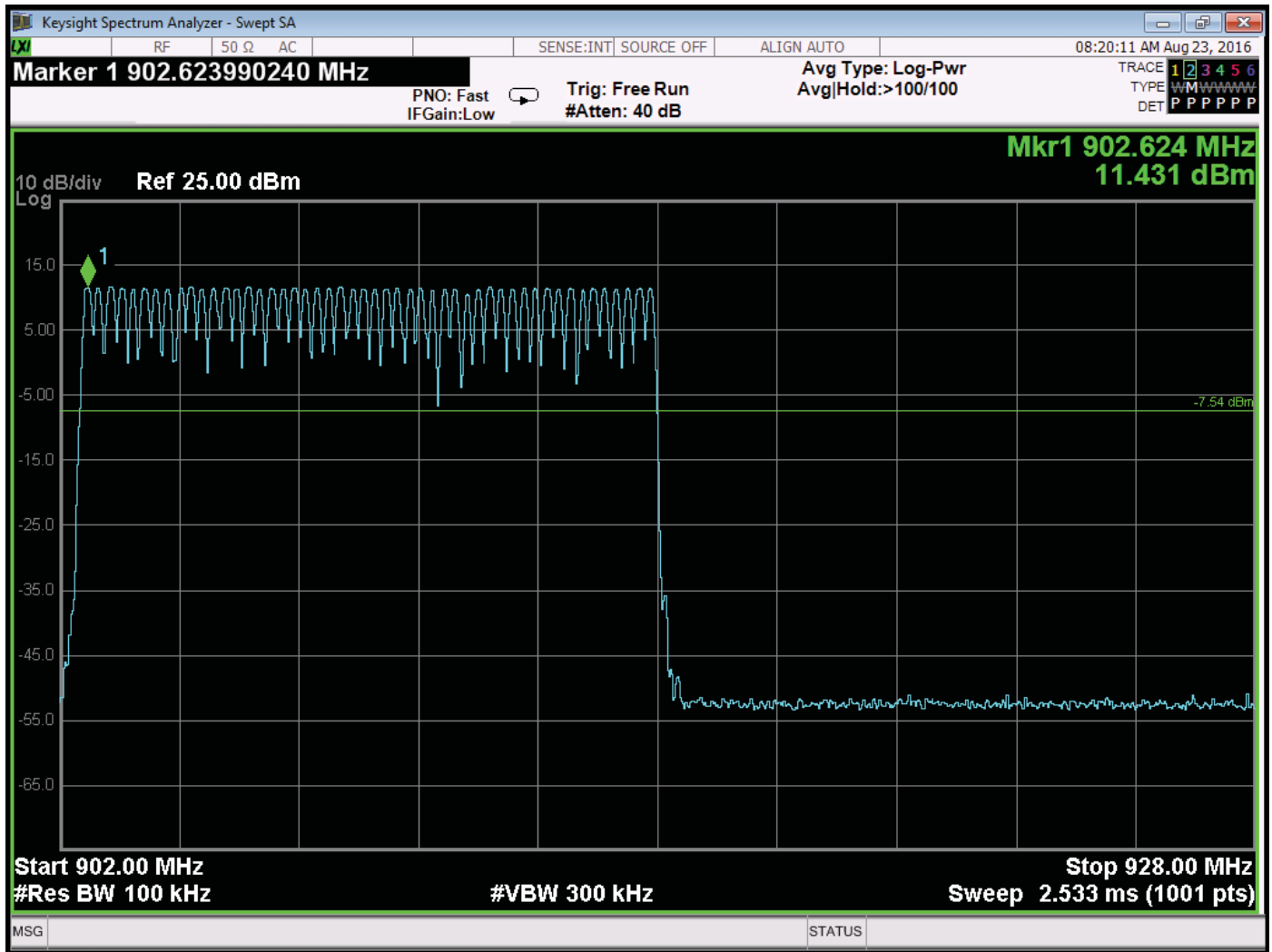

Number of Channels is 50 – 902.62 MHz to 914.87 MHz Band

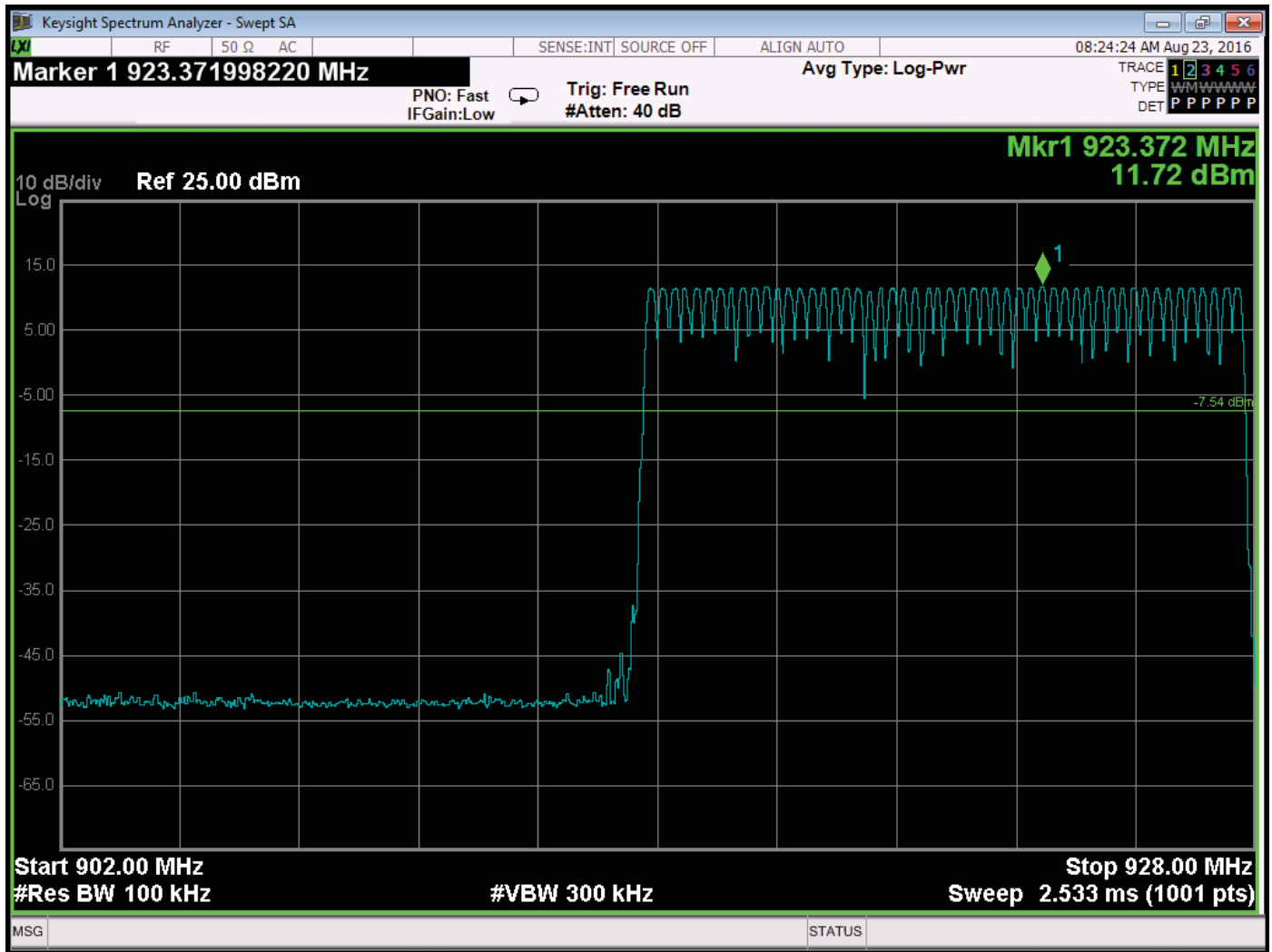

Number of Channels is 52 – 914.87 MHz to 927.62 MHz Band



***TIME OF OCCUPANCY  
DATA SHEETS***



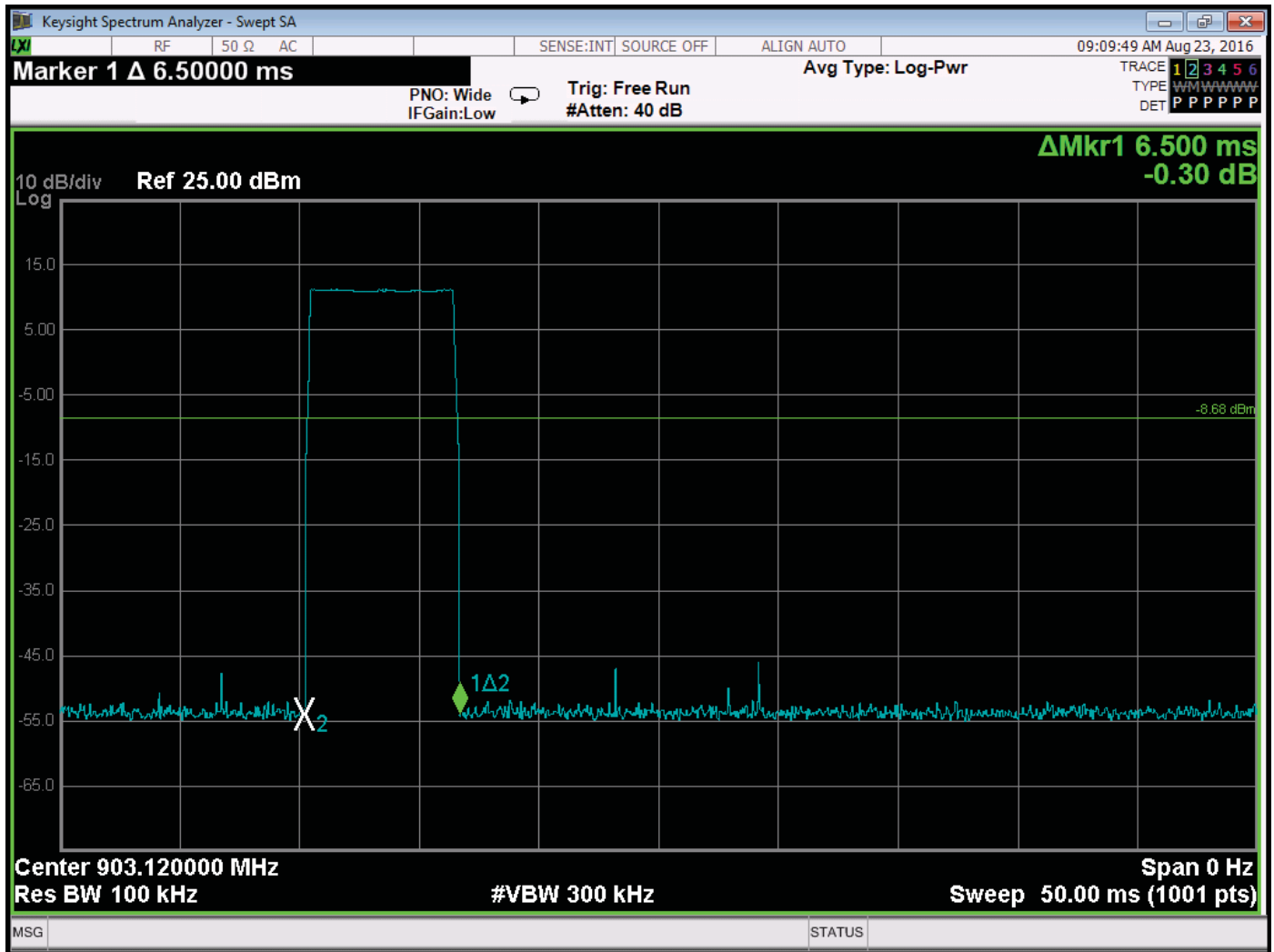

Time of One Pulse – 6.5 ms

Note: Worst Case Mode of low band hop table used, which results in the pulses appearing more frequently.

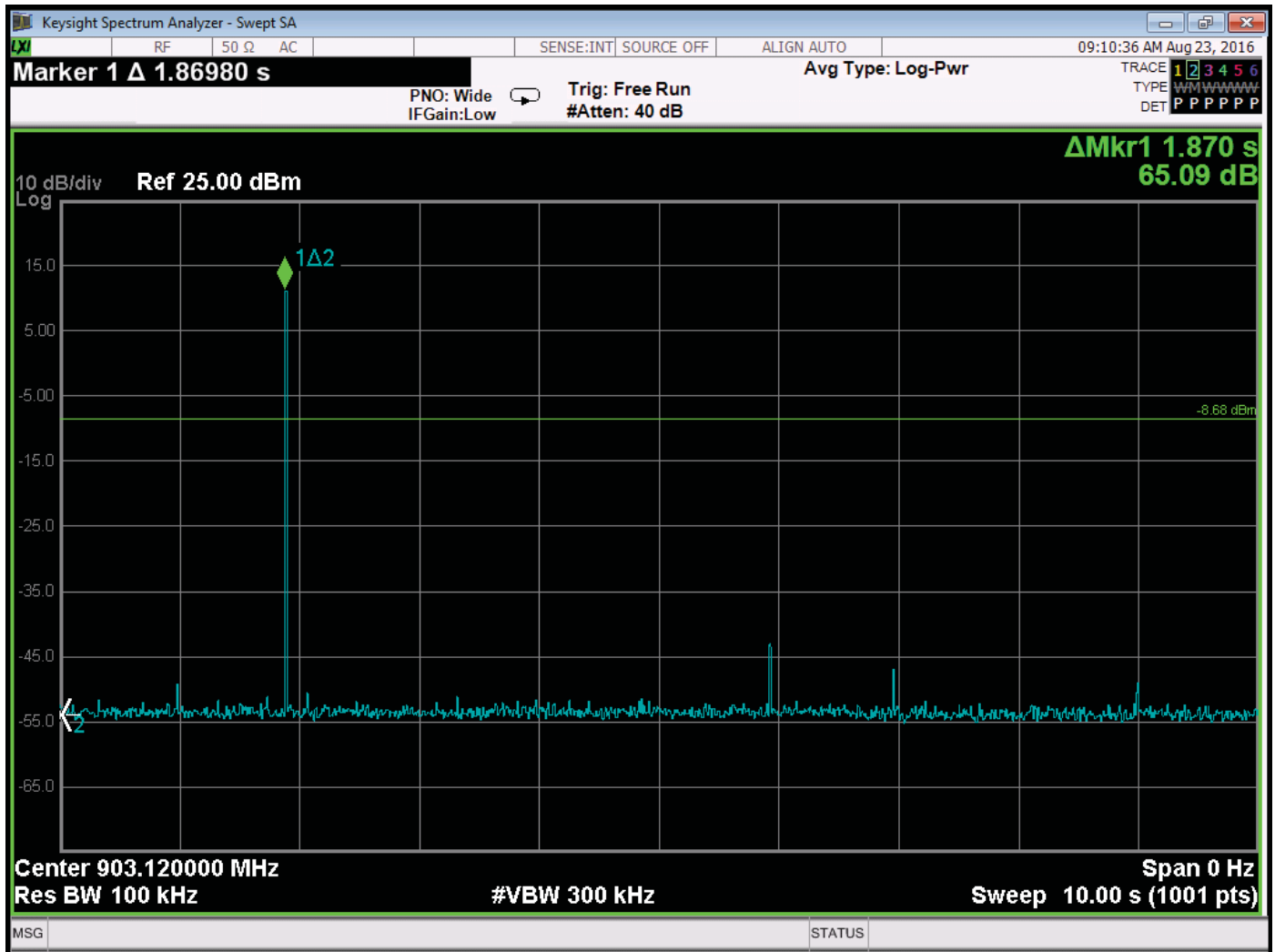

One Pulse Per 10 Seconds  
 Total of two pulses per 20 seconds worst case.  
 Total Time = 13.0 ms per 20 seconds  
 Limit = 400 ms per 20 seconds  
 Note: Worst Case Mode of low band hop table used, which results in the pulses appearing more frequently.

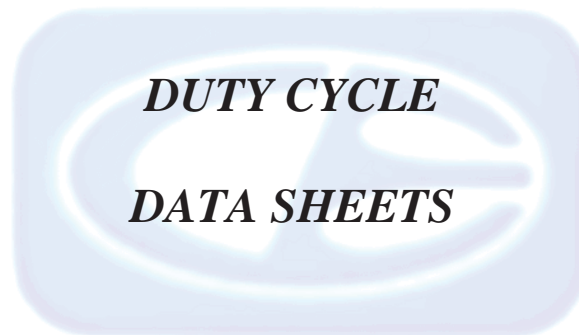

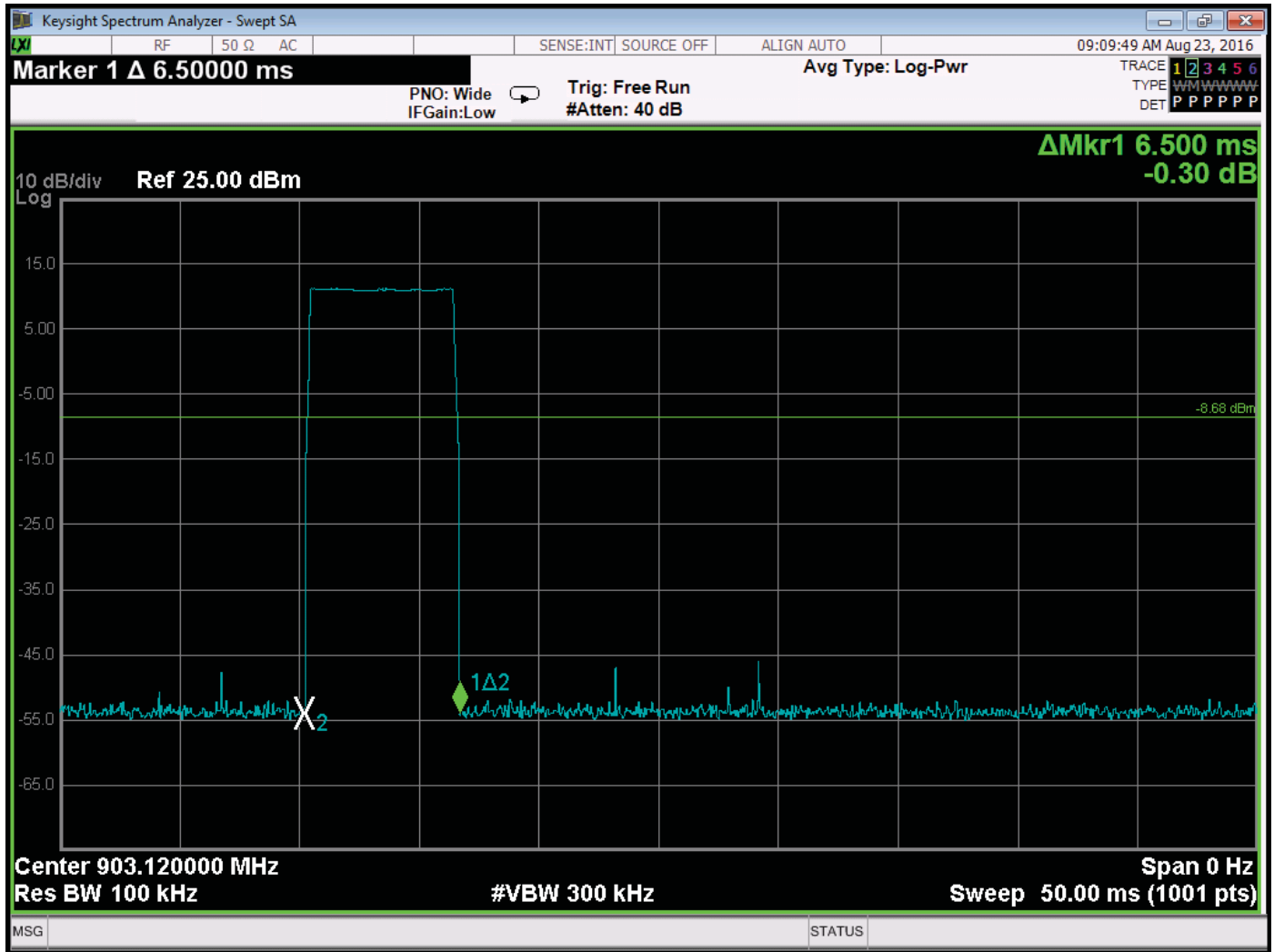

Time of One Pulse – 6.5 ms

Note: Worst Case Mode of low band hop table used, which results in the pulses appearing more frequently.

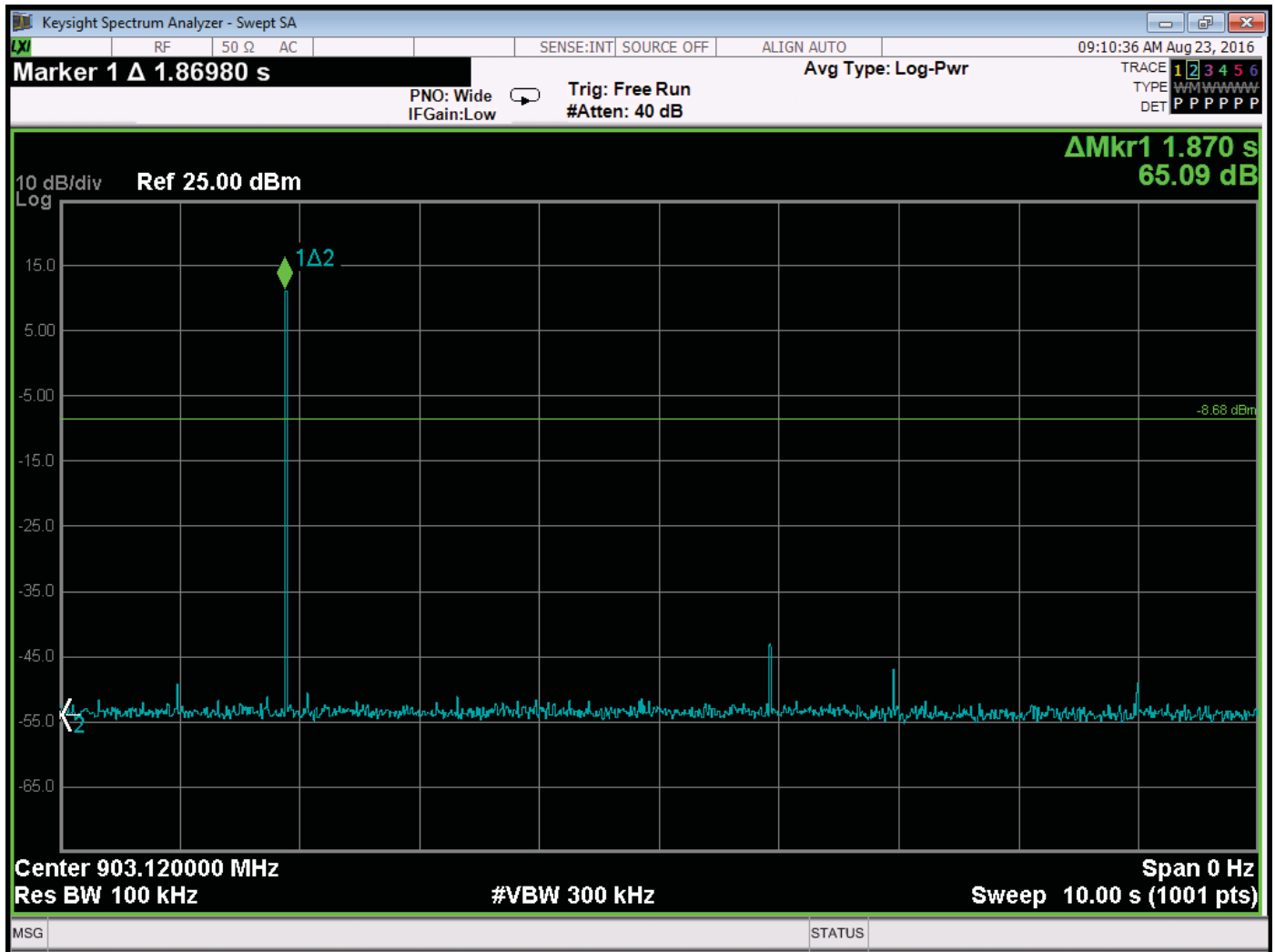

One pulse per 10 Seconds  
 Total duty cycle = 6.5 ms / 100 ms = 6.5%  
 Note: Worst Case Mode of low band hop table used, which results in the pulses appearing more frequently.