

*FCC PART 15, SUBPART B and C  
TEST REPORT*  
  
*for*  
**VPx SENSOR 900 MHz WITH LCD**  
**MODEL: CM-000272**

Prepared for

MESA LABS, INC.  
12100 WEST 6<sup>TH</sup> AVENUE  
LAKEWOOD, COLORADO 80228

Prepared by: *Kyle Fujimoto*

KYLE FUJIMOTO

Approved by: *James Ross*

JAMES ROSS

COMPATIBLE ELECTRONICS INC.  
114 OLINDA DRIVE  
BREA, CALIFORNIA 92823  
(714) 579-0500

DATE: SEPTEMBER 28, 2016

	REPORT BODY	APPENDICES					TOTAL
		A	B	C	D	E	
PAGES	21	2	2	2	17	79	123

This report shall not be reproduced except in full, without the written approval of Compatible Electronics.



**TABLE OF CONTENTS**

<b>Section / Title</b>	<b>PAGE</b>
<b>GENERAL REPORT SUMMARY</b>	<b>4</b>
<b>SUMMARY OF TEST RESULTS</b>	<b>5</b>
<b>1. PURPOSE</b>	<b>6</b>
<b>2. ADMINISTRATIVE DATA</b>	<b>7</b>
2.1 Location of Testing	7
2.2 Traceability Statement	7
2.3 Cognizant Personnel	7
2.4 Date Test Sample was Received	7
2.5 Disposition of the Test Sample	7
2.6 Abbreviations and Acronyms	7
<b>3. APPLICABLE DOCUMENTS</b>	<b>8</b>
<b>4. DESCRIPTION OF TEST CONFIGURATION</b>	<b>9</b>
4.1.1 Description of Test Configuration – Emissions	10
<b>5. LISTS OF EUT, ACCESSORIES AND TEST EQUIPMENT</b>	<b>11</b>
5.1 EUT and Accessory List	11
<b>6. TEST SITE DESCRIPTION</b>	<b>13</b>
6.1 Test Facility Description	13
6.2 EUT Mounting, Bonding and Grounding	13
<b>7. CHARACTERISTICS OF THE TRANSMITTER</b>	<b>14</b>
7.1 Channel Number and Frequencies	14
7.2 Antenna	14
<b>8. TEST PROCEDURES</b>	<b>15</b>
8.1 RF Emissions	15
8.1.1 Conducted Emissions Test	15
8.1.2 Radiated Emissions Test	16
8.1.3 RF Emissions Test Results	17
8.2 20 dB Bandwidth	18
8.3 Peak Output Power	18
8.4 RF Antenna Conducted Test	18
8.5 RF Band Edges	19
8.6 Carrier Frequency Separation	19
8.7 Number of Hopping Frequencies	19
8.8 Average Time of Occupancy Test	19
8.9 Fundamental Field Strength (Duty Cycle Calculations)	20
<b>9. CONCLUSIONS</b>	<b>21</b>

**LIST OF APPENDICES**

<b>APPENDIX</b>	<b>TITLE</b>
A	Laboratory Accreditations and Recognitions
B	Modifications to the EUT
C	Additional Models Covered Under This Report
D	Diagrams and Charts <ul style="list-style-type: none"><li>• Test Setup Diagrams</li><li>• Antenna and Effective Gain Factors</li></ul>
E	Data Sheets

**LIST OF FIGURES**

<b>FIGURE</b>	<b>TITLE</b>
1	Conducted Emissions Test Setup
2	Layout of the Semi-Anechoic Test Chamber

---

## GENERAL REPORT SUMMARY

This electromagnetic emission test report is generated by Compatible Electronics Inc., which is an independent testing and consulting firm. The test report is based on testing performed by Compatible Electronics personnel according to the measurement procedures described in the test specifications given below and in the "Test Procedures" section of this report.

The measurement data and conclusions appearing herein relate only to the sample tested and this report may not be reproduced without the written permission of Compatible Electronics, unless done so in full.

This report must not be used to claim product certification, approval or endorsement by NVLAP, NIST or any agency of the federal government.

Device Tested: VPx Sensor 900 MHz with LCD  
Models: CM-000272  
S/N: N/A

Product Description: The EUT a wireless sensor system to monitor the storage of vaccines.

Modifications: The EUT was not modified in order to meet the specifications.

Customer: Mesa Labs, Inc.  
12100 West 6th Avenue  
Lakewood, Colorado 80228

Test Dates: July 27, 28, and 31, 2016; August 29, 2016; November 17, 2016; and January 31, 2017

Test Specification covered by accreditation:



Test Specifications: Emissions requirements  
CFR Title 47, Part 15, Subpart B; and Subpart C, sections 15.205, 15.207, 15.209, and 15.247

Test Procedure: ANSI C63.4, ANSI C63.10

Test Deviations: The test procedure was not deviated from during the testing.

### SUMMARY OF TEST RESULTS

TEST	DESCRIPTION	RESULTS
1	Conducted RF Emissions, 150 kHz - 30 MHz	Complies with the <b>Class B</b> limits of CFR Title 47, Part 15, Subpart B; and the limits of CFR Title 47, Part 15, Subpart C, section 15.207. Highest reading in relation to spec limit: 24.44 dBuV @ 0.290 MHz (*U = 2.86 dB)
2	Radiated RF Emissions, 10 kHz – 9300 MHz	Complies with the <b>Class B</b> limits of CFR Title 47, Part 15, Subpart B; and the limits of CFR Title 47, Part 15 Subpart C, 15.205, 15.209 and 15.247 (d) Highest reading in relation to spec limit: 44.94 dBuV @ 2706.75 MHz (*U = 3.70 dB)
3	20 dB Bandwidth	Complies with the relevant requirements of CFR Title 47, Part 15, Subpart C, section 15.247 (a)(1)(i)
4	Peak Power Output	Complies with the relevant requirements of FCC Title 47, Part 15, Subpart C, section 15.247 (b)(2)
5	RF Conducted Antenna Test	Complies with the relevant requirements of FCC Title 47, Part 15, Subpart C, section 15.247 (d)
6	Carrier Frequency Separation	Complies with the relevant requirements of CFR Title 47, Part 15, Subpart C, section 15.247 (a)(1)
7	Average Time of Occupancy	Complies with the relevant requirements of CFR Title 47, Part 15, Subpart C, section 15.247 (a)(1)(i)
8	Peak Power Spectral Density from the International Radiator to the Antenna	This test was not performed because the EUT is a frequency hopper.

---

**1. PURPOSE**

This document is a qualification test report based on the emissions tests performed on the VPx Sensor 900 MHz With LCD, Models: CM-000272. The emissions measurements were performed according to the measurement procedure described in ANSI C63.4 and ANSI C63.10. The tests were performed in order to determine whether the electromagnetic emissions from the equipment under test, referred to as EUT hereafter, are within the Class B specification limits defined by CFR Title 47, Part 15, Subpart B; and Subpart C, sections 15.205, 15.207, 15.209, and 15.247.



### 3. APPLICABLE DOCUMENTS

The following documents are referenced or used in the preparation of this emissions Test Report.

<b>SPEC</b>	<b>TITLE</b>
FCC Title 47, Part 15 Subpart C	FCC Rules – Radio frequency devices (including digital devices) – Intentional Radiators
FCC Title 47, Part 15 Subpart B	FCC Rules – Radio frequency devices (including digital devices) – Unintentional Radiators
EN 50147-2: 1997	Anechoic chambers. Alternative test site suitability with respect to site attenuation
ANSI C63.4 2014	American National Standard for Methods of Measurement of Radio-Noise Emissions from Low-Voltage Electrical and Electronic Equipment in the Range of 9 kHz to 40 GHz
ANSI C63.10 2013	American National Standard for Testing Unlicensed Wireless Devices



#### 4. DESCRIPTION OF TEST CONFIGURATION

**AC Power Mode:** The VPx Sensor 900 MHz with LCD, Model: CM-000272 (EUT) was connected to (2) RTD probes, I2C temperature-humidity sensor, and power supply via its J1 and J2; J4; and power ports, respectively. The J3 port of the EUT was also connected to an unterminated cable.

**Battery Mode:** The VPx Sensor 900 MHz with LCD, Model: CM-000272 (EUT) was connected to (2) RTD probes and I2C temperature-humidity sensor via its J1 and J2; and J4 ports, respectively. The J3 port of the EUT was also connected to an unterminated cable.

For both modes, the USB port is only for diagnostic purposes only and thus left unterminated.

**For operating the EUT for the intentional radiator portion of the test:** The EUT was connected to a laptop that had a program that locked one channel at a time so that the low, middle, and high channels could be tested. The EUT was tested in two orthogonal axis. The carrier was modulated in the same way it would be when the EUT was in its normal operating mode.

**For operating the EUT for the unintentional radiator and conducted emission portion of the test:** The EUT was connected to a laptop that allowed the EUT to function as normal.

**For operating the EUT in receive mode:** The EUT was connected to a laptop that had a program that locked one channel at a time so that the low, middle, and high channel could be tested. The EUT was tested in two orthogonal axis. The LO of the receiver for the low, middle, and high channels were then tested.

**Note:** The laptop was only connected to the EUT to program the correct configuration and then was removed during the testing.

The X-Axis is when the EUT is parallel to the ground reference plane. The Y-Axis is when the EUT is perpendicular to the ground reference plane.

The final radiated data for the EUT as well as the conducted data was taken in modes above. Please see Appendix E for the data sheets.

#### **4.1.1 Description of Test Configuration – Emissions**

##### **Cable 1 (For AC Mode Only)**

This is a 2-meter unshielded cable connecting the power supply to the EUT. The cable is hard wired at the power supply end and has a 1/8 inch power connector at the EUT end. The cable was bundled to a length of 1-meter.

##### **Cable 2**

This is a 3.65-meter unshielded cable connecting the EUT to the RTD sensor #1. The cable has a 4-pin terminal block at the EUT end and is hard wired into RTD sensor #1. The cable was bundled to so that it remained 40-centimeters above the ground plane.

##### **Cable 3**

This is a 3.65-meter unshielded cable connecting the EUT to the RTD sensor #2. The cable has a 4-pin terminal block at the EUT end and is hard wired into RTD sensor #2. The cable was bundled to so that it remained 40-centimeters above the ground plane.

##### **Cable 4**

This a 2-meter unshielded, unterminated cable connected to the EUT. The cable has a 2-pin terminal block at the EUT end. The cable was bundled to so that it remained 40-centimeters above the ground plane.

##### **Cable 5**

This is a 10-centimeter cable connecting the EUT to the I2C temperature-humidity sensor. The cable has an RJ-11 connector at the EUT end and is hard wired into the I2C temperature-humidity sensor.

## 5. LISTS OF EUT, ACCESSORIES AND TEST EQUIPMENT

### 5.1 EUT and Accessory List

EQUIPMENT	MANUFACTURER	MODEL NUMBER	SERIAL NUMBER	FCC ID
VPx SENSOR 900 MHz WITH LCD (EUT)	MESA LABS, INC.	CM-000272	52000001	UUYVPX900
RTD SENSOR #1	MESA LABS, INC.	CM-000186	132394	N/A
RTD SENSOR #2	MESA LABS, INC.	CM-000186	132377	N/A
I2C TEMPERATURE-HUMIDITY SENSOR	N/A	N/A	N/A	N/A
POWER SUPPLY FOR VPx SENSOR 900 MHz WITH LCD	V-INFINITY	EPS050100	NA	N/A
AC ADAPTER FOR LAPTOP	HEWLETT PACKARD	PPP012D-S	WCNXF0ACX3OCXS	N/A
LAPTOP	HEWLETT PACKARD	PROBOOK 6560B	N/A	N/A

**5.2 Emissions Test Equipment**

EQUIPMENT TYPE	MANUFACTURER	MODEL NUMBER	SERIAL NUMBER	CALIBRATION DATE	CAL. CYCLE
<b>GENERAL TEST EQUIPMENT USED IN LAB D</b>					
TDK TestLab	TDK RF Solutions, Inc.	9.22	700145	N/A	N/A
Computer	Hewlett Packard	p6716f	MXX1030PX0	N/A	N/A
LCD Monitor	Hewlett Packard	52031a	3CQ046N3MG	N/A	N/A
EMI Receiver, 20 Hz – 26.5 GHz	Agilent Technologies	N9038A	MY51100115	April 3, 2015	2 Year
<b>RF RADIATED EMISSIONS TEST EQUIPMENT</b>					
CombiLog Antenna	Com-Power	AC-220	61060	September 3, 2015	1 Year
Preamplifier	Com-Power	PAM-118A	551024	May 12, 2016	1 Year
Loop Antenna	Com-Power	AL-130	17089	February 6, 2015	2 Year
Horn Antenna	Com-Power	AH-118	071175	February 26, 2016	2 Year
Antenna Mast	Com Power	AM-100	N/A	N/A	N/A
System Controller	Sunol Sciences Corporation	SC110V	112213-1	N/A	N/A
Turntable	Sunol Sciences Corporation	2011VS	N/A	N/A	N/A
Antenna-Mast	Sunol Sciences Corporation	TWR95-4	112213-3	N/A	N/A
<b>RF CONDUCTED EMISSIONS TEST EQUIPMENT</b>					
LISN	Com-Power	LI-215A	191951	June 9, 2015	2 Year
Transient Limiter	Com-Power	252A910	N/A	October 14, 2015	1 Year
<b>VARIATION OF THE INPUT POWER TEST EQUIPMENT</b>					
Variable Auto Transformer	Staco Energy Products	3PN1010	N/A	N/A	N/A
Multimeter	Fluke	87	58450372	March 17, 2016	1 Year

**6. TEST SITE DESCRIPTION****6.1 Test Facility Description**

Please refer to section 2.1 and 7.1 of this report for emissions test location.

**6.2 EUT Mounting, Bonding and Grounding**

**For frequencies 1 GHz and below:** The EUT was mounted on a 1.0 by 1.5 meter non-conductive table 0.8 meters above the ground plane.

**For frequencies above 1 GHz:** The EUT was mounted on a 1.0 by 1.5 meter non-conductive table 1.5 meters above the ground plane.

The EUT was not grounded.

## 7. CHARACTERISTICS OF THE TRANSMITTER

The following sections describe the test methods and the specifications for the tests. Test results are also included in this section.

### 7.1 Channel Number and Frequencies

The FHSS uses at least a minimum of 50 channels minimum using a pseudo random technique. It uses GFSK modulation. The channels are separated by approximately 250 kHz.

The three subbands that the EUT can operate on are:

1. 906.12 MHz to 924.12 MHz, which contains 60 channels
2. 902.62 MHz to 914.87 MHz, which contains 50 channels
3. 914.87 MHz to 927.62 MHz, which contains 52 channels

See Appendix E for the each plot showing the total number of channels in each subband.

### 7.2 Antenna

The antenna is a chip antenna which is located on the PCB.

## 8. TEST PROCEDURES

The following sections describe the test methods and the specifications for the tests. Test results are also included in this section.

### 8.1 RF Emissions

#### 8.1.1 Conducted Emissions Test

The EMI Receiver was used as a measuring meter. A quasi-peak and/or average reading was taken only where indicated in the data sheets. A transient limiter was used for the protection of the EMI Receiver input stage, and the offset was adjusted accordingly to read the actual data measured. The LISN output was measured using the EMI Receiver. The output of the second LISN was terminated by a 50-ohm termination. The effective measurement bandwidth used for this test was 9 kHz.

Please see section 6.2 of this report for mounting, bonding, and grounding of the EUT. The EUT was powered through the LISN, which was bonded to the ground plane. The LISN power was filtered and the filter was bonded to the ground plane. The EUT was set up with the minimum distances from any conductive surfaces as specified in ANSI 63:4. The excess power cord was wrapped in a figure eight pattern to form a bundle not exceeding 0.4 meters in length.

The conducted emissions from the EUT were maximized for operating mode as well as cable placement. The final data was collected under program control by computer software. The final qualification data is located in Appendix E.

The EUT was tested at 120 VAC. The six highest emissions are listed in Table 1.0.

#### **Test Results:**

The EUT complies with the **Class B** limits of CFR Title 47, Part 15, Subpart B; and the limits of CFR Title 47, Part 15, Subpart C, Section 15.207 for conducted emissions. Please see Appendix E for the data sheets.

### 8.1.2 Radiated Emissions Test

The EMI Receiver was used as the measuring meter. A built-in, internal preamplifier was used to increase the sensitivity of the instrument. The EMI Receiver was initially used with the Analyzer mode feature activated. In this mode, the EMI receiver can then record the actual frequency to be measured. This final reading is then taken accurately in the EMI Receiver mode, which takes into account the cable loss, amplifier gain and antenna factors, so that a true reading is compared to the true limit. A quasi-peak reading was taken only for those readings, which are marked accordingly on the data sheets. The effective measurement bandwidth used for the radiated emissions test was according to the frequency measured (200 Hz for 10 kHz to 150 kHz, 9 kHz for 150 kHz to 30 MHz, 120 kHz for 30 MHz to 1 GHz and 1 MHz for 1 GHz to 9.3 GHz).

The frequencies above 1 GHz were averaged by using duty cycle correction factor.

The EMI test chamber of Compatible Electronics, Inc. was used for radiated emissions testing. This test site is in full compliance with ANSI C63.4. Please see section 6.2 of this report for mounting, bonding and grounding of the EUT. The turntable supporting the EUT is remote controlled using a motor. The turntable permits EUT rotation of 360 degrees in order to maximize emissions. Also, the antenna mast allows height variation of the antenna from 1 meter to 4 meters. Data was collected in the worst case (highest emission) configuration of the EUT. At each reading, the EUT was rotated 360 degrees and the antenna height was varied from 1 to 4 meters (for E field radiated field strength). The gunsight method was used when measuring with the horn antenna in order to ensure accurate results.

The EUT was tested at a 3-meter test distance. The six highest emissions are listed in Table 2.0.

The measurement bandwidths and transducers used for the radiated emissions test were:

FREQUENCY RANGE	EFFECTIVE MEASUREMENT BANDWIDTH	TRANSDUCER
10 kHz to 150 kHz	200 Hz	Loop Antenna
150 kHz to 30 MHz	9 kHz	Loop Antenna
30 MHz to 1 GHz	120 kHz	CombiLog Antenna
1 GHz to 9.3 GHz	1 MHz	Horn Antenna

#### Test Results:

The EUT complies with the **Class B** limits of **CFR** Title 47, Part 15, Subpart B; and Subpart C sections 15.205, 15.209, and 15.247 (d) for radiated emissions.



### 8.1.3 RF Emissions Test Results

Table 1.0 CONDUCTED EMISSION RESULTS  
 VPx Sensor 900 MHz with LCD  
 Models: CM-000272

Frequency MHz	Average Corrected Reading* dBuV	Average Specification Limit dBuV	Delta (Cor. Reading – Spec. Limit) dB
0.342 (BL) (Tx)	37.99 (Average)	49.16	-11.17
0.346 (BL) (Tx)	36.86 (Average)	49.28	-12.42
0.350 (BL) (Tx)	36.68 (Average)	49.14	-12.46
0.338 (BL) (Tx)	36.68 (Average)	49.17	-12.49
0.358 (BL) (Tx)	36.57 (Average)	49.13	-12.57
0.174 (WL) (Rx)	41.93 (Average)	55.02	-13.09

Table 2.0 RADIATED EMISSION RESULTS  
 VPx Sensor 900 MHz with LCD  
 Models: CM-000272

Frequency MHz	EMI Reading (dBuV)	Specification Limit (dBuV)	Delta (Cor. Reading – Spec. Limit) dB
7320.96 (H) (Y-Axis) (AC)	49.07 (Average)	53.97	-4.90
248.00 (V) (Tx) (AC)	40.59 (Quasi-Peak)	46.00	-5.41
211.30 (H) (Tx) (AC)	37.43 (Quasi-Peak)	43.50	-6.07
212.00 (H) (Tx) (AC)	36.75 (Quasi-Peak)	43.50	-6.75
7420.96 (V)(X-Axis)(AC)	46.31 (Average)	53.97	-7.66
200.90 (V)(Tx)(AC)	35.62 (Quasi-Peak)	43.50	-7.88

Notes:

- \* The complete emissions data is given in Appendix E of this report.
- (BL) Black Lead
- (WL) White Lead
- (V) Vertical
- (H) Horizontal

## 8.2 20 dB Bandwidth

The 20 dB Bandwidth was measured using the EMI Receiver. The bandwidth was measured using a direct connection from the RF output of the EUT. The resolution bandwidth was  $\geq 1\%$  of the bandwidth and the video bandwidth was  $\geq$  RBW.

### Test Results:

The EUT complies with the relevant requirements of FCC Title 47, Part 15, Subpart C section 15.247 (a)(1)(i). The 20 dB bandwidth is less than the separation between channels. Please see the data sheets located in Appendix E.

## 8.3 Peak Output Power

The Peak Output Power was measured using the EMI Receiver. The peak output power was measured using a direct connection from the RF output of the EUT. The resolution bandwidth was greater than 20 dB bandwidth and the video bandwidth was  $\geq$  RBW. The cable loss was also added back into the reading using the reference level offset.

### Test Results:

The EUT complies with the relevant requirements of FCC Title 47, Part 15, Subpart C section 15.247 (b)(2). The maximum peak output power is less than 1 Watt. Please see the data sheets located in Appendix E.

## 8.4 RF Antenna Conducted Test

The RF antenna conducted test was performed using the EMI Receiver. The RF antenna conducted test measured using a direct connection from the RF out on the EUT into the input of the EMI Receiver. The resolution bandwidth was 100 kHz, and the video bandwidth was 300 kHz. The spans were wide enough to include all the harmonics and emissions that were produced by the intentional radiator.

### Test Results:

The EUT complies with the relevant requirements of FCC Title 47, Part 15, Subpart C section 15.247 (d). The RF power that is produced by the intentional radiator is at least 20 dB below that in the 100 kHz bandwidth within the band that contains the highest level of desired power. Please see the radiated emission data sheets located in Appendix E.

## 8.5 RF Band Edges

The RF band edges were taken at the edges of the ISM spectrum (902 MHz when the EUT was on the low channel and 928 MHz when the EUT was on the high channel) using the EMI Receiver. The RBW was set to 100 kHz and the VBW was set to 300 kHz. Plots of the fundamental were taken to ensure the amplitude at the band edges were at least 20 dB down from the peak of the fundamental emission. The plots were taken in both frequency hopping mode and single channel mode.

### Test Results:

The EUT complies with the relevant requirements of FCC Title 47, Part 15, Subpart C section 15.247 (d). The RF power at the band edges at 902 MHz and 928 MHz meet the requirements of FCC Title 47, Part 15, Subpart C section 15.247 (d). Please see the data sheets located in Appendix E.

## 8.6 Carrier Frequency Separation

The Channel Hopping Separation Test was measured using the EMI Receiver. The EUT was operating in its normal operating mode. The resolution bandwidth was approximately 30% of the channel spacing, and the video bandwidth  $\geq$  RBW. The frequency span was wide enough to include the peaks of two adjacent channels.

### Test Results:

The EUT complies with the relevant requirements of FCC Title 47, Part 15, Subpart C section 15.247 (a)(1). The Channel Hopping Separation is greater than the 20 dB bandwidth. Please see the data sheets located in Appendix E.

## 8.7 Number of Hopping Frequencies

The Number of Hopping Frequencies was measured using the EMI Receiver. The EUT was operating in its normal operating mode. The resolution bandwidth was set to approximately 30% of the channel spacing, and the video bandwidth was  $\geq$  RBW. The frequency span was wide enough to include all of the peaks in the frequency band of operation.

### Test Results:

The EUT complies with the relevant requirements of FCC Title 47, Part 15, Subpart C section 15.247 (a)(1) and 15.247 (a)(1)(i). Please see the data sheets located in Appendix E.

## 8.8 Average Time of Occupancy Test

The Average Time of Occupancy Test was measured using the EMI Receiver. The EUT was operating in normal operating mode. The frequency span was taken to 0 Hz to determine the time for each transmission and the number of transmissions over a 20 second period. The RBW was set to be less than the channel spacing. The low hop band table was determined to be the worst case because this mode results in the pulses appearing more frequently.

### Test Results:

The EUT complies with the relevant requirements of FCC Title 47, Part 15, Subpart C section 15.247 (a)(1)(i). Please see the data sheets located in Appendix E.

## 8.9 Fundamental Field Strength (Duty Cycle Calculations)

The Peak Transmit Radiated Field Strength was measured at a 3-meter test distance. The EMI Receiver was used to obtain the duty cycle. The data sheets are located in Appendix E.

Where

$$\delta(\text{dB}) = 20 \log \left[ \frac{\sum (nt_1 + mt_2 + \dots + \xi t_x)}{T} \right]$$

$n$  is the number of pulses of duration  $t_1$

$m$  is the number of pulses of duration  $t_2$

$\xi$  is the number of pulses of duration  $t_x$

$T$  is the period of the pulse train or 100 ms if the pulse train length is greater than 100 ms

Duty Cycle Correction Factor = -20.00dB

Pulse = 1 \* 9 mS

Total On Time = 9 mS

Duty Cycle Train was longer than 100mS; therefore 100mS span was used.

9 mS / 100 mS = 9%

20 log (0.09) = -20.92 dB correction factor

**Max Duty Cycle Correction Factor = -20.00dB**

## 8.10 Variation of the Input Power

The variation of the input power test was performed using the EMI Receiver. The EUT input power was varied between 85% and 115% of the nominal rated supply voltage. The carrier frequency was monitored for any change in amplitude.

### Test Results:

The EUT complies with the relevant requirements of FCC Title 47, Part 15, Subpart C section 15.31(e).

## 9. CONCLUSIONS

The VPx Sensor 900 MHz with LCD, Model: CM-000272, as tested, meets all of the specification limits defined in FCC Title 47, Part 15, Subpart B; and Subpart C, sections 15.205, 15.207, 15.209, and 15.247.

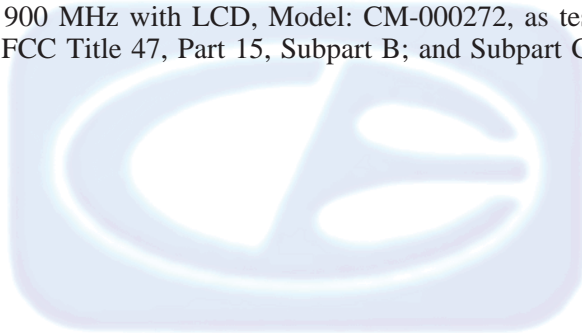



**APPENDIX A**

***LABORATORY ACCREDITATIONS AND RECOGNITIONS***

---

**Brea Division**  
114 Olinda Drive  
Brea, CA 92823  
(714) 579-0500

**Agoura Division**  
2337 Troutdale Drive  
Agoura, CA 91301  
(818) 597-0600

**Silverado Division**  
19121 El Toro Road  
Silverado, CA 92676  
(949) 589-0700

**Lake Forest Division**  
20621 Pascal Way  
Lake Forest, CA 92630  
(949) 587-0400

## LABORATORY ACCREDITATIONS AND RECOGNITIONS



NVLAP LAB CODE 200528-0

® For US, Canada, Australia/New Zealand, Japan, Taiwan, Korea, and the European Union, Compatible Electronics is currently accredited by NVLAP to ISO/IEC 17025.

**For the most up-to-date version of our scopes and certificates please visit**  
<http://celectronics.com/quality/scope/>

Quote from ISO-ILAC-IAF Communiqué on 17025:

"A laboratory's fulfilment of the requirements of ISO/IEC 17025:2005 means the laboratory meets both the technical competence requirements and management system requirements that are necessary for it to consistently deliver technically valid test results and calibrations. The management system requirements in ISO/IEC 17025:2005 (Section 4) are written in language relevant to laboratory operations and meet the principles of ISO 9001:2008 Quality Management Systems — Requirements."



ANSI listing [CETCB](#)



Compatible Electronics has been nominated as a Conformity Assessment Body (CAB) for EMC under the US/EU Mutual Recognition Agreement (MRA).

US/EU MRA list [NIST MRA site](#)



Compatible Electronics has been nominated as a Conformity Assessment Body (CAB) for Taiwan/BSMI under the US/APEC (Asia-Pacific Economic Cooperation) Mutual Recognition Agreement (MRA).

APEC MRA list [NIST MRA site](#)

We are also listed for IT products by the following country/agency:



VCCI Support member: Please visit [http://www.vcci.jp/vcci\\_e/](http://www.vcci.jp/vcci_e/)



FCC Listing, from FCC OET site

[FCC test lab search](https://fjallfoss.fcc.gov/oetcf/eas/reports/TestFirmSearch.cfm) <https://fjallfoss.fcc.gov/oetcf/eas/reports/TestFirmSearch.cfm>



Compatible Electronics IC listing can be found at:

<http://www.ic.gc.ca/eic/site/ic1.nsf/eng/home>

**Brea Division**  
114 Olinda Drive  
Brea, CA 92823  
(714) 579-0500

**Agoura Division**  
2337 Troutdale Drive  
Agoura, CA 91301  
(818) 597-0600

**Silverado Division**  
19121 El Toro Road  
Silverado, CA 92676  
(949) 589-0700

**Lake Forest Division**  
20621 Pascal Way  
Lake Forest, CA 92630  
(949) 587-0400



**APPENDIX B**

***MODIFICATIONS TO THE EUT***



---

## MODIFICATIONS TO THE EUT

The modifications listed below were made to the EUT to pass FCC Subpart B and FCC 15.247 specifications.

All the rework described below was implemented during the test in a method that could be reproduced in all the units by the manufacturer.

No modifications were made to the EUT during the testing.





**APPENDIX C**

***ADDITIONAL MODELS COVERED  
UNDER THIS REPORT***

---

**Brea Division**  
114 Olinda Drive  
Brea, CA 92823  
(714) 579-0500

**Agoura Division**  
2337 Troutdale Drive  
Agoura, CA 91301  
(818) 597-0600

**Silverado Division**  
19121 El Toro Road  
Silverado, CA 92676  
(949) 589-0700

**Lake Forest Division**  
20621 Pascal Way  
Lake Forest, CA 92630  
(949) 587-0400

## **ADDITIONAL MODELS COVERED UNDER THIS REPORT**

USED FOR THE PRIMARY TEST

VPx Sensor 900 MHz With LCD  
Models: CM-000272  
S/N: N/A

There are no additional models covered under this report.



**APPENDIX D**

***DIAGRAMS AND CHARTS***

**FIGURE 1: CONDUCTED EMISSIONS TEST SETUP**

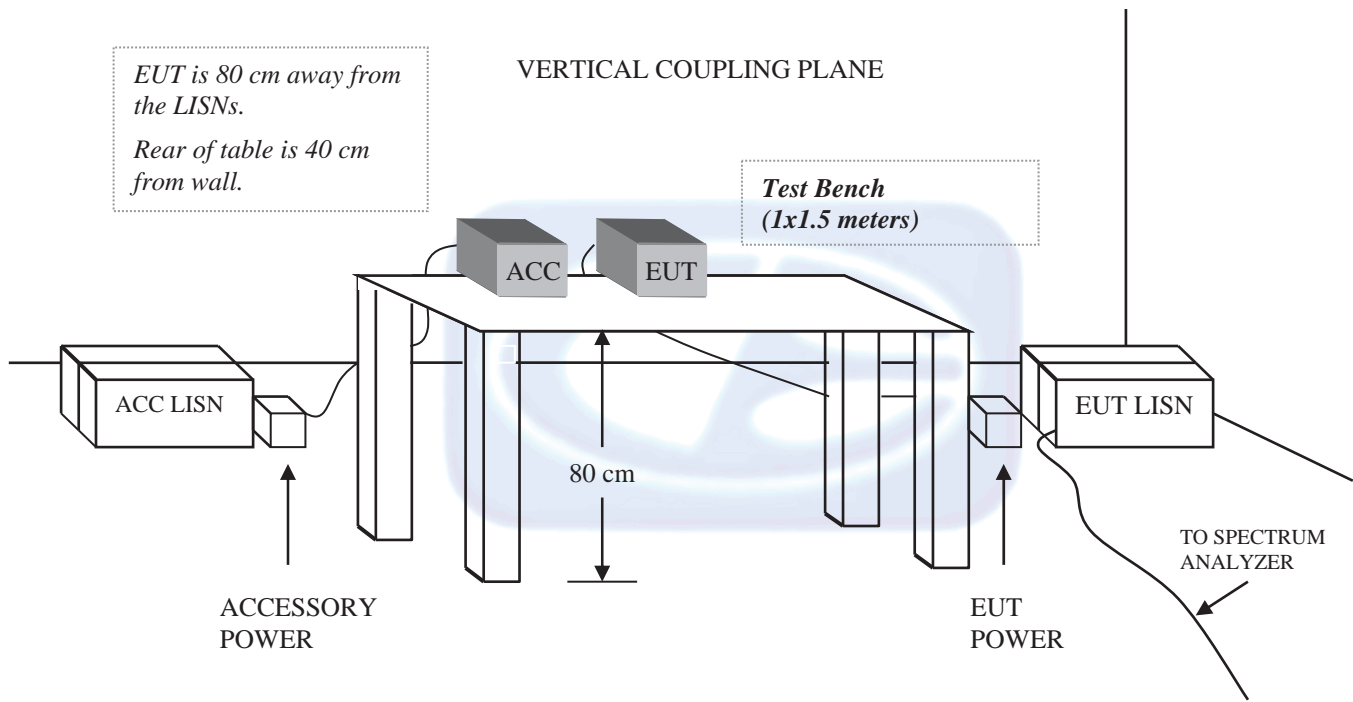

**FIGURE 2: LAYOUT OF THE SEMI MI-ANECHOIC TEST CHAMBER**

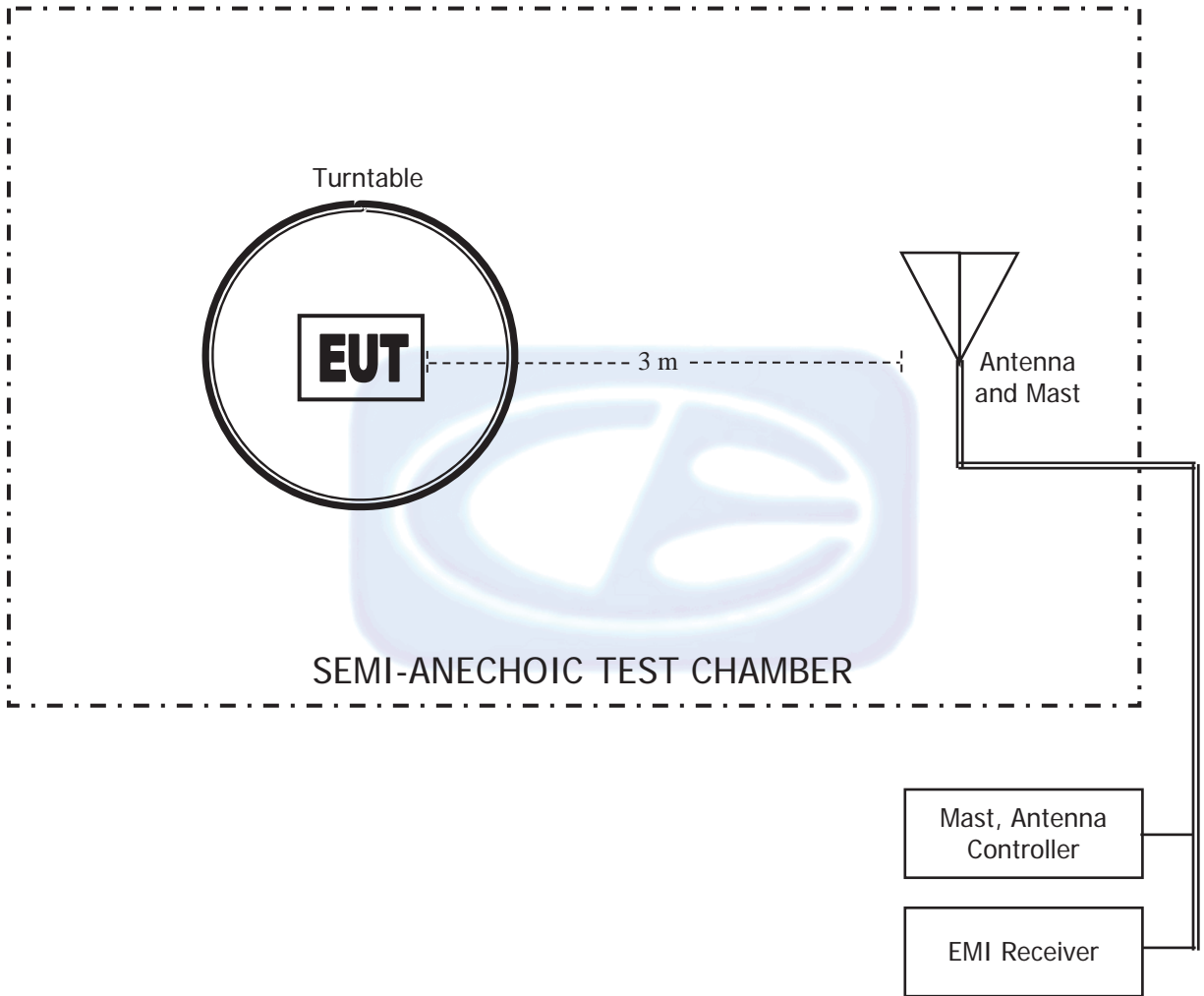

**COM-POWER AL-130****LOOP ANTENNA**

S/N: 17089

CALIBRATION DATE: FEBRUARY 6, 2015

<b>FREQUENCY (MHz)</b>	<b>MAGNETIC (dB/m)</b>	<b>ELECTRIC (dB/m)</b>
0.009	-33.18	18.32
0.01	-34.10	17.40
0.02	-38.65	12.85
0.03	-39.28	12.22
0.04	-40.09	11.41
0.05	-40.85	10.65
0.06	-40.88	10.62
0.07	-41.07	10.43
0.08	-41.04	10.46
0.09	-41.19	10.31
0.1	-41.20	10.30
0.2	-41.52	9.98
0.3	-41.53	9.97
0.4	-41.42	10.08
0.5	-41.53	9.97
0.6	-41.53	9.97
0.7	-41.43	10.07
0.8	-41.23	10.27
0.9	-41.13	10.37
1	-41.14	10.36
2	-40.80	10.70
3	-40.66	10.84
4	-40.61	10.89
5	-40.33	11.17
6	-40.53	10.97
7	-40.47	11.03
8	-40.48	11.02
9	-39.93	11.57
10	-39.81	11.69
15	-43.35	8.15
20	-39.16	12.34
25	-40.24	11.26
30	-43.18	8.32

**COM-POWER AC-220****COMBILOG ANTENNA****S/N: 61060****CALIBRATION DATE: SEPTEMBER 3, 2015**

<b>FREQUENCY (MHz)</b>	<b>FACTOR (dB)</b>	<b>FREQUENCY (MHz)</b>	<b>FACTOR (dB)</b>
30	24.00	200	13.00
35	24.30	250	15.30
40	25.40	300	18.20
45	21.50	350	17.90
50	22.50	400	18.60
60	15.40	450	19.80
70	12.70	500	21.60
80	11.10	550	22.40
90	13.40	600	23.70
100	13.80	650	24.30
120	15.40	700	24.00
125	15.40	750	24.50
140	13.10	800	24.30
150	17.20	850	26.30
160	13.20	900	26.90
175	14.20	950	26.00
180	14.30	1000	25.60



**COM POWER AH-118****HORN ANTENNA**

S/N: 071175

CALIBRATION DATE: FEBRUARY 26, 2016

<b>FREQUENCY (GHz)</b>	<b>FACTOR (dB)</b>	<b>FREQUENCY (GHz)</b>	<b>FACTOR (dB)</b>
1.0	23.93	10.0	39.33
1.5	25.54	10.5	39.64
2.0	28.09	11.0	41.04
2.5	30.21	11.5	44.29
3.0	30.15	12.0	41.22
3.5	30.17	12.5	41.50
4.0	31.90	13.0	41.62
4.5	33.51	13.5	40.63
5.0	33.87	14.0	39.94
5.5	35.08	14.5	41.84
6.0	34.81	15.0	42.69
6.5	34.26	15.5	39.03
7.0	36.33	16.0	39.07
7.5	37.03	16.5	41.40
8.0	37.56	17.0	43.18
8.5	40.07	17.5	47.01
9.0	38.92	18.0	46.48
9.5	38.21		

**COM-POWER PA-118****PREAMPLIFIER**

S/N: 551024

CALIBRATION DATE: MAY 12, 2016

<b>FREQUENCY (GHz)</b>	<b>FACTOR (dB)</b>	<b>FREQUENCY (GHz)</b>	<b>FACTOR (dB)</b>
1.0	39.84	6.0	39.05
1.1	39.40	6.5	38.94
1.2	39.58	7.0	39.25
1.3	39.68	7.5	39.09
1.4	39.91	8.0	39.01
1.5	39.78	8.5	38.60
1.6	39.50	9.0	38.64
1.7	39.81	9.5	39.67
1.8	39.89	10.0	39.30
1.9	39.94	11.0	39.15
2.0	39.57	12.0	39.24
2.5	40.39	13.0	39.49
3.0	40.63	14.0	39.44
3.5	40.80	15.0	39.94
4.0	40.86	16.0	40.09
4.5	39.94	17.0	40.06
5.0	34.47	18.0	39.76
5.5	39.32		

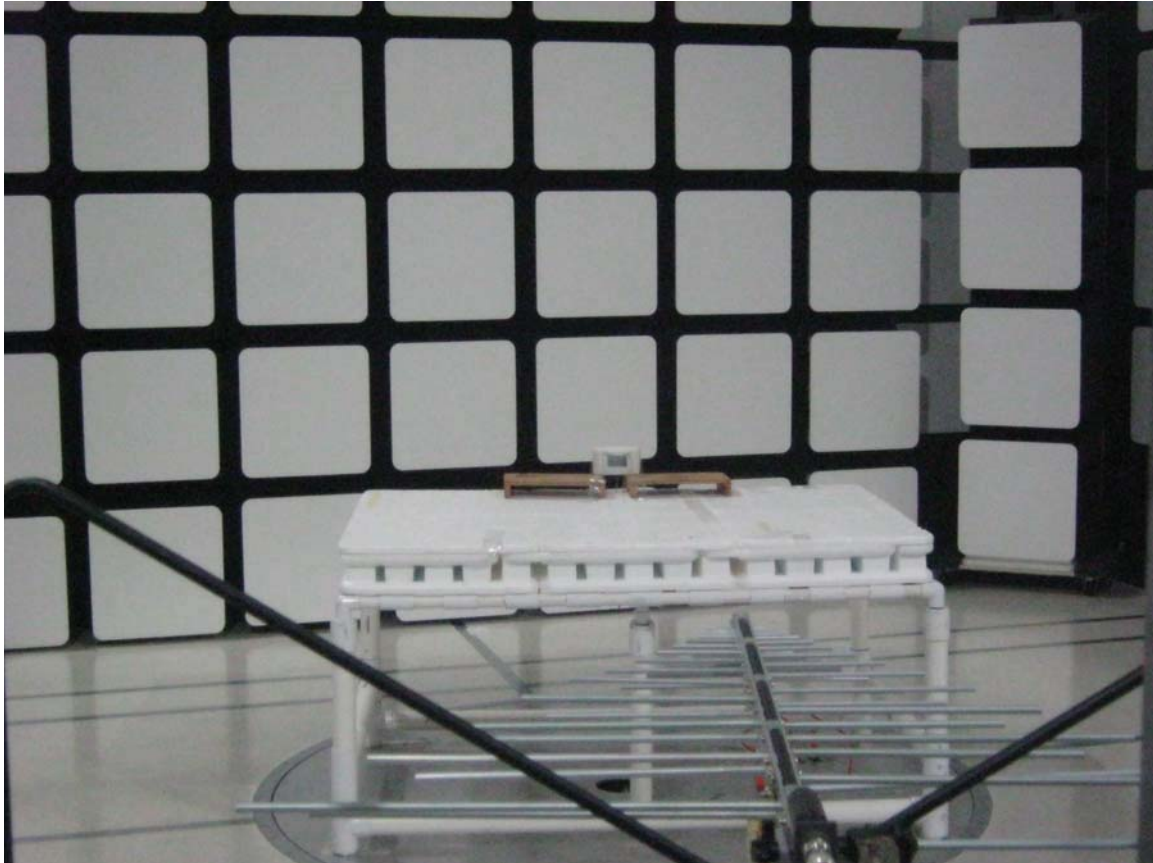

**FRONT VIEW**

MESA LABS, INC.  
VPX SENSOR 900 MHz WITH LCD  
MODEL: CM-000272

FCC SUBPART B AND C – RADIATED EMISSIONS – BELOW 1 GHz – BATTERY MODE

**PHOTOGRAPH SHOWING THE EUT CONFIGURATION  
FOR MAXIMUM EMISSIONS**

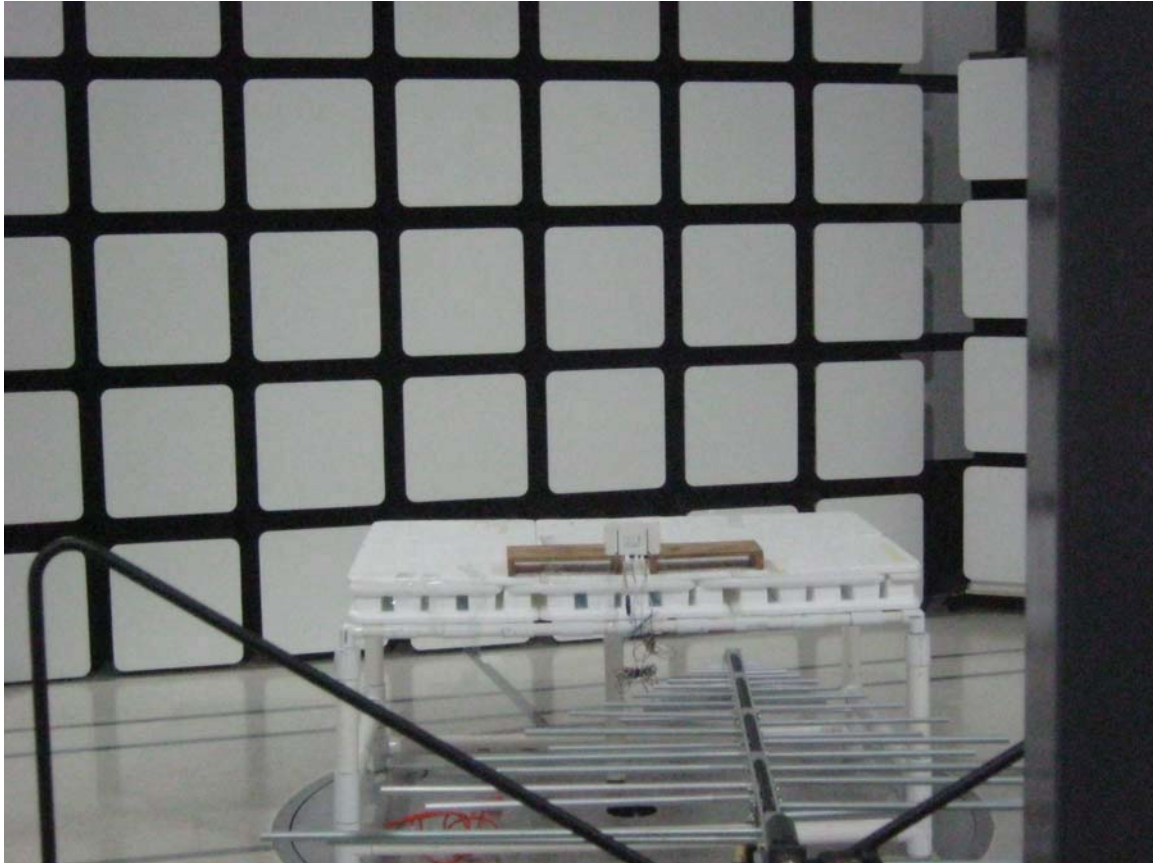

**REAR VIEW**

MESA LABS, INC.  
VPX SENSOR 900 MHz WITH LCD  
MODEL: CM-000272  
FCC SUBPART B AND C – RADIATED EMISSIONS – BELOW 1 GHz – BATTERY MODE

**PHOTOGRAPH SHOWING THE EUT CONFIGURATION  
FOR MAXIMUM EMISSIONS**

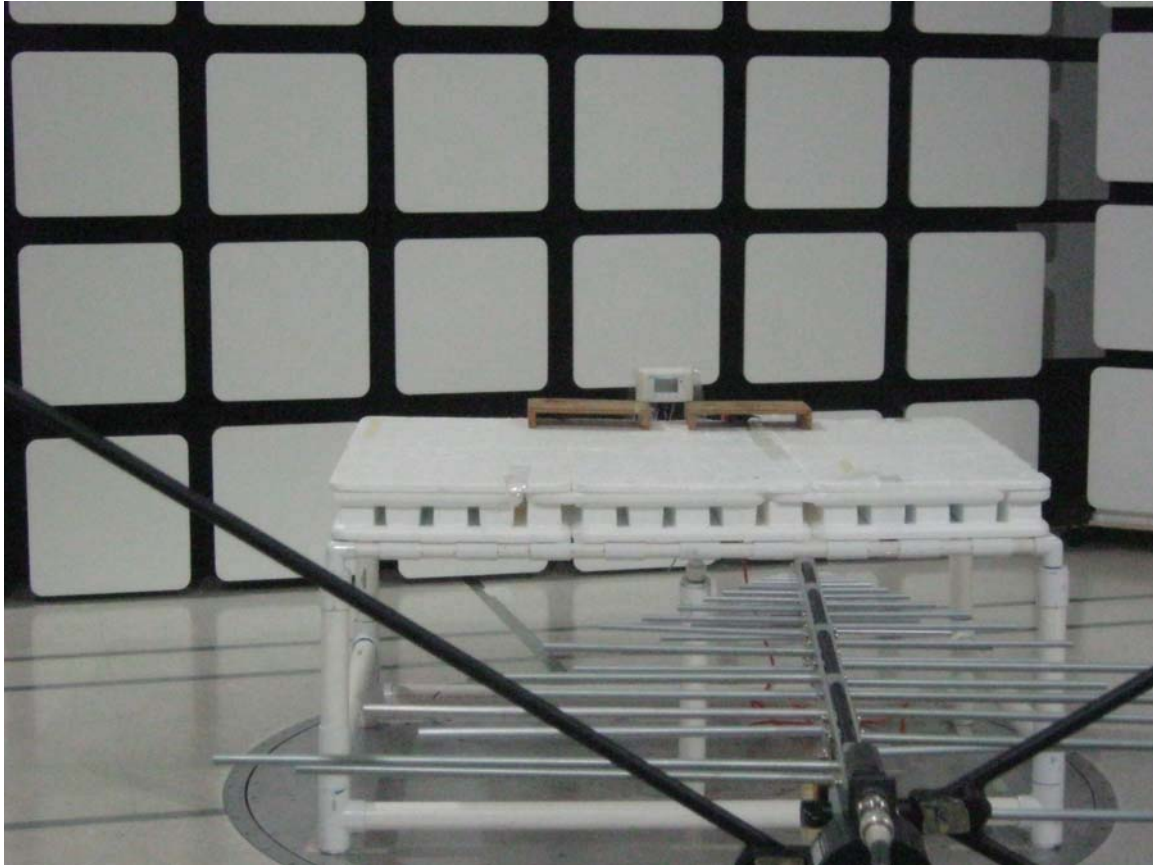

**FRONT VIEW**

MESA LABS, INC.  
VPX SENSOR 900 MHz WITH LCD  
MODEL: CM-000272  
FCC SUBPART B AND C – RADIATED EMISSIONS – BELOW 1 GHz – AC MODE

**PHOTOGRAPH SHOWING THE EUT CONFIGURATION  
FOR MAXIMUM EMISSIONS**



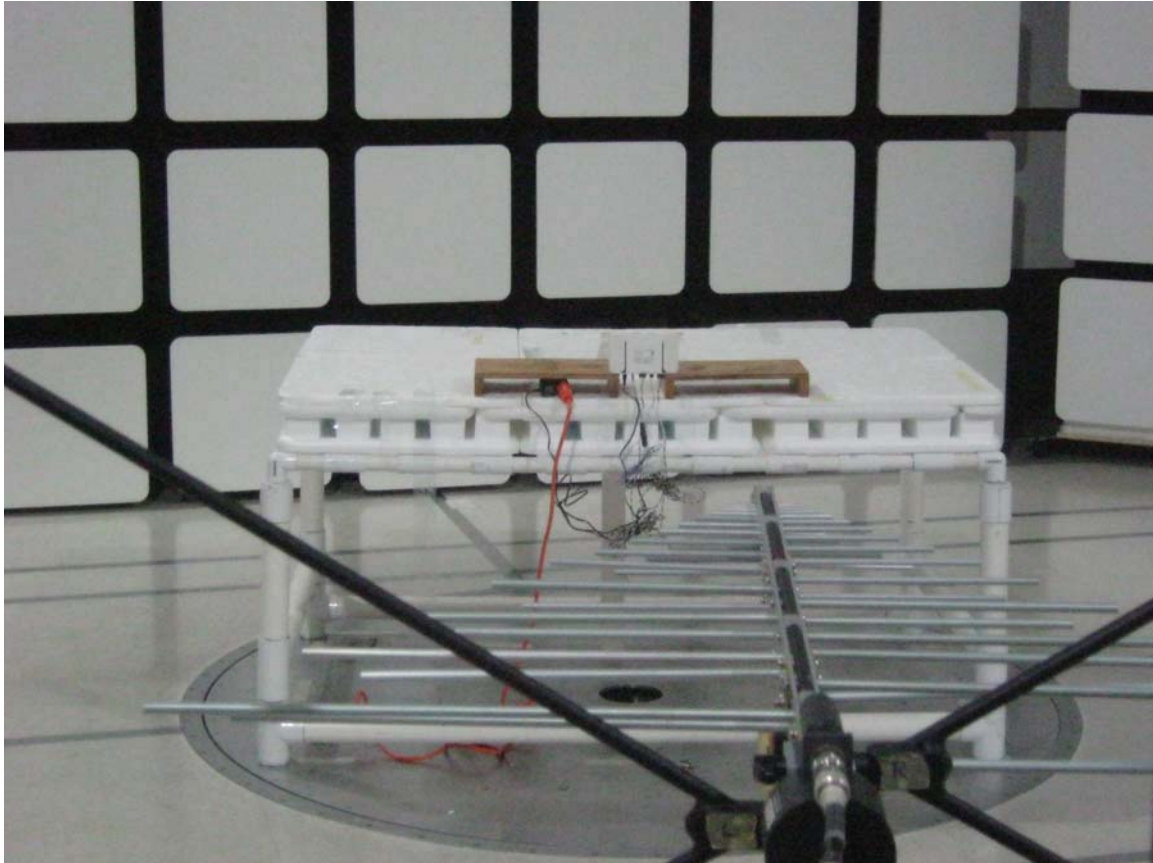

**REAR VIEW**

MESA LABS, INC.  
VPX SENSOR 900 MHz WITH LCD  
MODEL: CM-000272  
FCC SUBPART B AND C – RADIATED EMISSIONS – BELOW 1 GHz – AC MODE

**PHOTOGRAPH SHOWING THE EUT CONFIGURATION  
FOR MAXIMUM EMISSIONS**

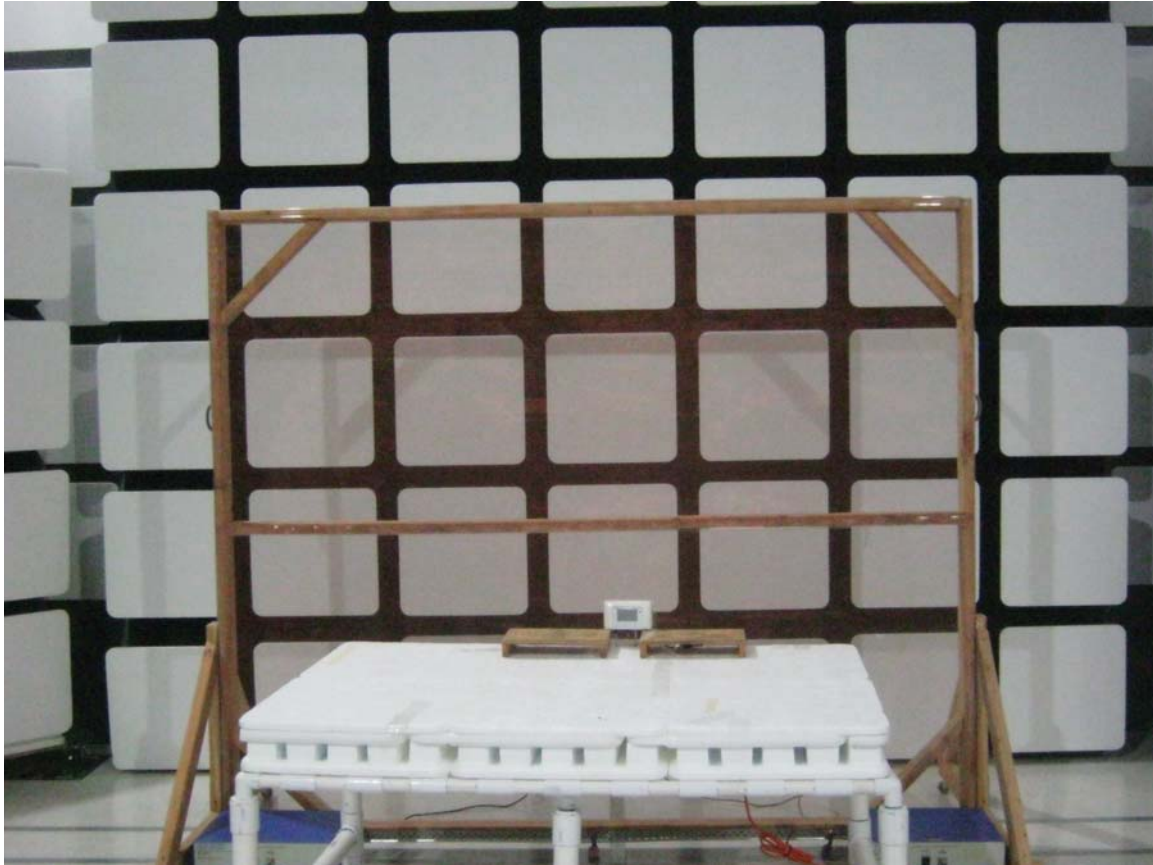

**FRONT VIEW**

MESA LABS, INC.  
VPx SENSOR 900 MHz WITH LCD  
MODEL: CM-000272  
FCC SUBPART B AND C – CONDUCTED EMISSIONS

**PHOTOGRAPH SHOWING THE EUT CONFIGURATION  
FOR MAXIMUM EMISSIONS**



**REAR VIEW**

MESA LABS, INC.  
VPx SENSOR 900 MHz WITH LCD  
MODEL: CM-000272  
FCC SUBPART B AND C – CONDUCTED EMISSIONS

**PHOTOGRAPH SHOWING THE EUT CONFIGURATION  
FOR MAXIMUM EMISSIONS**





**FRONT VIEW**

MESA LABS, INC.  
VPX SENSOR 900 MHZ WITH LCD  
MODEL: CM-000272

FCC SUBPART B AND C – RADIATED EMISSIONS – BATTERY MODE – ABOVE 1 GHz

**PHOTOGRAPH SHOWING THE EUT CONFIGURATION  
FOR MAXIMUM EMISSIONS**

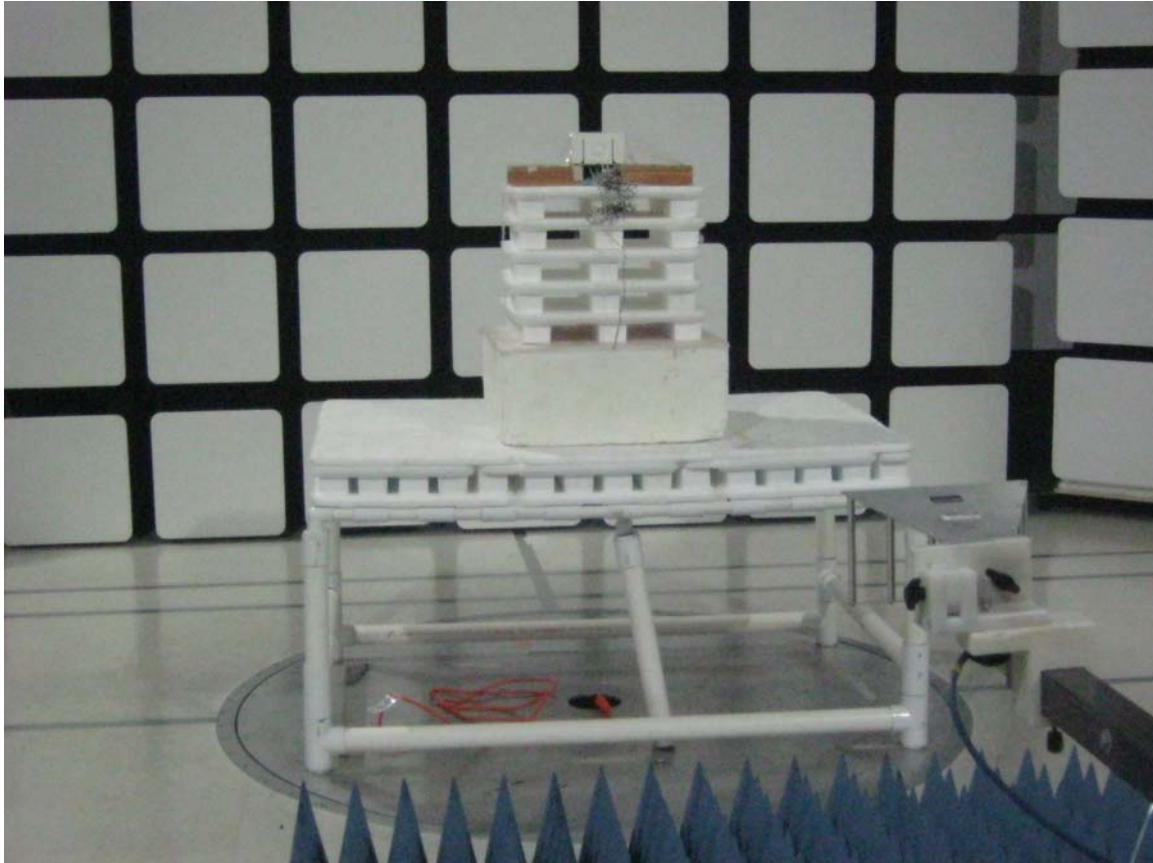

**REAR VIEW**

MESA LABS, INC.  
VPX SENSOR 900 MHZ WITH LCD  
MODEL: CM-000272

FCC SUBPART B AND C – RADIATED EMISSIONS – BATTERY MODE – ABOVE 1 GHz

**PHOTOGRAPH SHOWING THE EUT CONFIGURATION  
FOR MAXIMUM EMISSIONS**



**FRONT VIEW**

MESA LABS, INC.  
VPX SENSOR 900 MHZ WITH LCD  
MODEL: CM-000272  
FCC SUBPART B AND C – RADIATED EMISSIONS – AC MODE – ABOVE 1 GHz

**PHOTOGRAPH SHOWING THE EUT CONFIGURATION  
FOR MAXIMUM EMISSIONS**





**REAR VIEW**

MESA LABS, INC.  
VPX SENSOR 900 MHz WITH LCD  
MODEL: CM-000272  
FCC SUBPART B AND C – RADIATED EMISSIONS – AC MODE – ABOVE 1 GHz

**PHOTOGRAPH SHOWING THE EUT CONFIGURATION  
FOR MAXIMUM EMISSIONS**

**APPENDIX E**

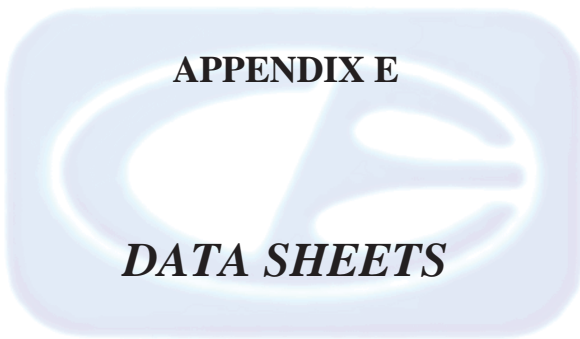

***DATA SHEETS***



***RADIATED EMISSIONS  
DATA SHEETS***

**FCC 15.247**

Mesa Labs, Inc.  
 VPx Sensor 900 MHz with LCD  
 Model: CM-000272

Date: 07/28/2016  
 Lab: D  
 Tested By: Kyle Fujimoto

**Battery Mode**  
**Low Channel - X-Axis**  
**Transmit Mode**

Freq. (MHz)	Level (dBuV/m)	Pol (v/h)	Limit	Margin	Peak / QP / Avg	Table Angle (deg)	Ant. Height (cm)	Comments
1805.24								Not in Restricted Band
1805.24								Done via Conducted
2707.86	54.39	V	73.97	-19.58	Peak	81.50	142.83	
2707.86	34.39	V	53.97	-19.58	Avg	81.50	142.83	
3610.48	48.90	V	73.97	-25.07	Peak	90.25	111.31	
3610.48	28.90	V	53.97	-25.07	Avg	90.25	111.31	
4513.1	57.58	V	73.97	-16.39	Peak	72.00	142.89	
4513.1	37.58	V	53.97	-16.39	Avg	72.00	142.89	
5415.72	48.91	V	73.97	-25.06	Peak	100.75	110.95	
5415.72	28.91	V	53.97	-25.06	Avg	100.75	110.95	
6318.34								Not in Restricted Band
6318.34								Done via Conducted
7220.96								Not in Restricted Band
7220.96								Done via Conducted
8123.58	50.42	V	73.97	-23.55	Peak	151.25	159.25	
8123.58	30.42	V	53.97	-23.55	Avg	151.25	159.25	
9026.2	43.85	V	73.97	-30.12	Peak	48.25	249.25	
9026.2	23.85	V	53.97	-30.12	Avg	48.25	249.25	



**FCC 15.247**

Mesa Labs, Inc.  
 VPx Sensor 900 MHz with LCD  
 Model: CM-000272

Date: 07/28/2016  
 Lab: D  
 Tested By: Kyle Fujimoto

**Battery Mode**  
**Low Channel - Y-Axis**  
**Transmit Mode**

Freq. (MHz)	Level (dBuV/m)	Poi (v/h)	Limit	Margin	Peak / QP / Avg	Table Angle (deg)	Ant. Height (cm)	Comments
1805.24								Not in Restricted Band
1805.24								Done via Conducted
2707.86	47.71	V	73.97	-26.26	Peak	116.50	175.25	
2707.86	27.71	V	53.97	-26.26	Avg	116.50	175.25	
3610.48	45.23	V	73.97	-28.74	Peak	129.50	191.31	
3610.48	25.23	V	53.97	-28.74	Avg	129.50	191.31	
4513.1	53.38	V	73.97	-20.59	Peak	185.50	127.25	
4513.1	33.38	V	53.97	-20.59	Avg	185.50	127.25	
5415.72	46.70	V	73.97	-27.27	Peak	164.25	127.25	
5415.72	26.70	V	53.97	-27.27	Avg	164.25	127.25	
6318.34								Not in Restricted Band
6318.34								Done via Conducted
7220.96								Not in Restricted Band
7220.96								Done via Conducted
8123.58	51.68	V	73.97	-22.29	Peak	148.75	127.37	
8123.58	31.68	V	53.97	-22.29	Avg	148.75	127.37	
9026.2	43.49	V	73.97	-30.48	Peak	161.75	157.88	
9026.2	23.49	V	53.97	-30.48	Avg	161.75	157.88	

**FCC 15.247**

Mesa Labs, Inc.  
 VPx Sensor 900 MHz with LCD  
 Model: CM-000272

Date: 07/28/2016  
 Lab: D  
 Tested By: Kyle Fujimoto

**Battery Mode**  
**Low Channel - X-Axis**  
**Transmit Mode**

Freq. (MHz)	Level (dBuV/m)	Pol (v/h)	Limit	Margin	Peak / QP / Avg	Table Angle (deg)	Ant. Height (cm)	Comments
1805.24								Not in Restricted Band
1805.24								Done via Conducted
2707.86	45.70	H	73.97	-28.27	Peak	305.50	158.95	
2707.86	25.70	H	53.97	-28.27	Avg	305.50	158.95	
3610.48	42.39	H	73.97	-31.58	Peak	303.00	127.31	
3610.48	22.39	H	53.97	-31.58	Avg	303.00	127.31	
4513.1	46.57	H	73.97	-27.40	Peak	86.75	143.01	
4513.1	26.57	H	53.97	-27.40	Avg	86.75	143.01	
5415.72	41.70	H	73.97	-32.27	Peak	146.50	142.95	
5415.72	21.70	H	53.97	-32.27	Avg	146.50	142.95	
6318.34								Not in Restricted Band
6318.34								Done Via Conducted
7220.96								Not in Restricted Band
7220.96								Done Via Conducted
8123.58	47.36	H	73.97	-26.61	Peak	358.50	223.13	
8123.58	27.36	H	53.97	-26.61	Avg	358.50	223.13	
9026.2	45.66	H	73.97	-28.31	Peak	4.75	127.01	
9026.2	25.66	H	53.97	-28.31	Avg	4.75	127.01	

**FCC 15.247**

Mesa Labs, Inc.  
 VPx Sensor 900 MHz with LCD  
 Model: CM-000272

Date: 07/28/2016  
 Lab: D  
 Tested By: Kyle Fujimoto

**Battery Mode**  
**Low Channel - Y-Axis**  
**Transmit Mode**

Freq. (MHz)	Level (dBuV/m)	Pol (v/h)	Limit	Margin	Peak / QP / Avg	Table Angle (deg)	Ant. Height (cm)	Comments
1805.24								Not in Restricted Band
1805.24								Done via Conducted
2707.86	50.34	H	73.97	-23.63	Peak	94.75	142.95	
2707.86	30.34	H	53.97	-23.63	Avg	94.75	142.95	
3610.48	48.65	H	73.97	-25.32	Peak	204.00	175.07	
3610.48	28.65	H	53.97	-25.32	Avg	204.00	175.07	
4513.1	58.27	H	73.97	-15.70	Peak	200.75	143.07	
4513.1	38.27	H	53.97	-15.70	Avg	200.75	143.07	
5415.72	48.93	H	73.97	-25.04	Peak	202.50	175.07	
5415.72	28.93	H	53.97	-25.04	Avg	202.50	175.07	
6318.34								Not in Restricted Band
6318.34								Done Via Conducted
7220.96								Not in Restricted Band
7220.96								Done Via Conducted
8123.58	55.09	H	73.97	-18.88	Peak	165.50	175.07	
8123.58	35.09	H	53.97	-18.88	Avg	165.50	175.07	
9026.2	50.82	H	73.97	-23.15	Peak	151.25	111.31	
9026.2	30.82	H	53.97	-23.15	Avg	151.25	111.31	

**FCC 15.247**

Mesa Labs, Inc.  
 VPx Sensor 900 MHz with LCD  
 Model: CM-000272

Date: 07/29/2016  
 Lab: D  
 Tested By: Kyle Fujimoto

**Battery Mode**  
**Middle Channel - X-Axis**  
**Transmit Mode**

Freq. (MHz)	Level (dBuV/m)	Pol (v/h)	Limit	Margin	Peak / QP / Avg	Table Angle (deg)	Ant. Height (cm)	Comments
1830.24								Not in Restricted Band
1830.24								Done via Conducted
2745.36	51.42	V	73.97	-22.55	Peak	343.00	125.94	
2745.36	31.42	V	53.97	-22.55	Avg	343.00	125.94	
3660.48	50.51	V	73.97	-23.46	Peak	36.25	143.19	
3660.48	30.51	V	53.97	-23.46	Avg	36.25	143.19	
4575.6	60.53	V	73.97	-13.44	Peak	205.25	159.13	
4575.6	40.53	V	53.97	-13.44	Avg	205.25	159.13	
5490.72								Not in Restricted Band
5490.72								Done via Conducted
6405.84								Not in Restricted Band
6405.84								Done via Conducted
7320.96	58.39	V	73.97	-15.58	Peak	295.00	159.31	
7320.96	38.39	V	53.97	-15.58	Avg	295.00	159.31	
8236.08	50.44	V	73.97	-23.53	Peak	157.25	110.95	
8236.08	30.44	V	53.97	-23.53	Avg	157.25	110.95	
9151.2	45.25	V	73.97	-28.72	Peak	359.50	250.00	
9151.2	25.25	V	53.97	-28.72	Avg	359.50	250.00	

**FCC 15.247**

Mesa Labs, Inc.  
 VPx Sensor 900 MHz with LCD  
 Model: CM-000272

Date: 07/29/2016  
 Lab: D  
 Tested By: Kyle Fujimoto

**Battery Mode**  
**Middle Channel - Y-Axis**  
**Transmit Mode**

Freq. (MHz)	Level (dBuV/m)	Pol (v/h)	Limit	Margin	Peak / QP / Avg	Table Angle (deg)	Ant. Height (cm)	Comments
1830.24								Not in Restricted Band
1830.24								Done via Conducted
2745.36	51.06	V	73.97	-22.91	Peak	98.00	191.13	
2745.36	31.06	V	53.97	-22.91	Avg	98.00	191.13	
3660.48	41.06	V	73.97	-32.91	Peak	111.25	191.19	
3660.48	21.06	V	53.97	-32.91	Avg	111.25	191.19	
4575.6	49.78	V	73.97	-24.19	Peak	177.25	100.73	
4575.6	29.78	V	53.97	-24.19	Avg	177.25	100.73	
5490.72								Not in Restricted Band
5490.72								Done via Conducted
6405.84								Not in Restricted Band
6405.84								Done via Conducted
7320.96	50.76	V	73.97	-23.21	Peak	143.25	222.41	
7320.96	30.76	V	53.97	-23.21	Avg	143.25	222.41	
8236.08	39.15	V	73.97	-34.82	Peak	143.50	223.43	
8236.08	19.15	V	53.97	-34.82	Avg	143.50	223.43	
9151.2	33.80	V	73.97	-40.17	Peak	165.00	127.19	
9151.2	13.80	V	53.97	-40.17	Avg	165.00	127.19	

**FCC 15.247**

Mesa Labs, Inc.  
 VPx Sensor 900 MHz with LCD  
 Model: CM-000272

Date: 07/29/2016  
 Lab: D  
 Tested By: Kyle Fujimoto

**Battery Mode**  
**Middle Channel - X-Axis**  
**Transmit Mode**

Freq. (MHz)	Level (dBuV/m)	Pol (v/h)	Limit	Margin	Peak / QP / Avg	Table Angle (deg)	Ant. Height (cm)	Comments
1830.24								Not in Restricted Band
1830.24								Done via Conducted
2745.36	37.67	H	73.97	-36.30	Peak	94.75	241.34	
2745.36	17.67	H	53.97	-36.30	Avg	94.75	241.34	
3660.48	39.09	H	73.97	-34.88	Peak	293.50	100.01	
3660.48	19.09	H	53.97	-34.88	Avg	293.50	100.01	
4575.6	54.58	H	73.97	-19.39	Peak	177.00	111.01	
4575.6	34.58	H	53.97	-19.39	Avg	177.00	111.01	
5490.72								Not in Restricted Band
5490.72								Done via Conducted
6405.84								Not in Restricted Band
6405.84								Done via Conducted
7320.96	55.21	H	73.97	-18.76	Peak	320.00	223.19	
7320.96	35.21	H	53.97	-18.76	Avg	320.00	223.19	
8236.08	48.49	H	73.97	-25.48	Peak	283.50	174.95	
8236.08	28.49	H	53.97	-25.48	Avg	283.50	174.95	
9151.2	48.85	H	73.97	-25.12	Peak	240.00	222.89	
9151.2	28.85	H	53.97	-25.12	Avg	240.00	222.89	

**FCC 15.247**

Mesa Labs, Inc.  
 VPx Sensor 900 MHz with LCD  
 Model: CM-000272

Date: 07/29/2016  
 Lab: D  
 Tested By: Kyle Fujimoto

**Battery Mode**  
**Middle Channel - Y-Axis**  
**Transmit Mode**

Freq. (MHz)	Level (dBuV/m)	Pol (v/h)	Limit	Margin	Peak / QP / Avg	Table Angle (deg)	Ant. Height (cm)	Comments
1830.24								Not in Restricted Band
1830.24								Done via Conducted
2745.36	56.25	H	73.97	-17.72	Peak	205.25	223.79	
2745.36	36.25	H	53.97	-17.72	Avg	205.25	223.79	
3660.48	46.72	H	73.97	-27.25	Peak	108.00	223.61	
3660.48	26.72	H	53.97	-27.25	Avg	108.00	223.61	
4575.6	55.10	H	73.97	-18.87	Peak	137.75	127.19	
4575.6	35.10	H	53.97	-18.87	Avg	137.75	127.19	
5490.72								Not in Restricted Band
5490.72								Done via Conducted
6405.84								Not in Restricted Band
6405.84								Done via Conducted
7320.96	58.90	H	73.97	-15.07	Peak	151.25	112.56	
7320.96	38.90	H	53.97	-15.07	Avg	151.25	112.56	
8236.08	43.95	H	73.97	-30.02	Peak	208.75	175.19	
8236.08	23.95	H	53.97	-30.02	Avg	208.75	175.19	
9151.2	39.60	H	73.97	-34.37	Peak	156.00	111.19	
9151.2	19.60	H	53.97	-34.37	Avg	156.00	111.19	



**FCC 15.247**

Mesa Labs, Inc.  
 VPx Sensor 900 MHz with LCD  
 Model: CM-000272

Date: 07/29/2016  
 Lab: D  
 Tested By: Kyle Fujimoto

**Battery Mode**  
**High Channel - X-Axis**  
**Transmit Mode**

Freq. (MHz)	Level (dBuV/m)	Pol (v/h)	Limit	Margin	Peak / QP / Avg	Table Angle (deg)	Ant. Height (cm)	Comments
1855.24								Not in Restricted Band
1855.24								Done via Conducted
2782.86	51.53	V	73.97	-22.44	Peak	49.25	207.25	
2782.86	31.53	V	53.97	-22.44	Avg	49.25	207.25	
3710.48	45.71	V	73.97	-28.26	Peak	204.25	111.25	
3710.48	25.71	V	53.97	-28.26	Avg	204.25	111.25	
4638.1	60.23	V	73.97	-13.74	Peak	27.50	111.37	
4638.1	40.23	V	53.97	-13.74	Avg	27.50	111.37	
5565.72								Not in Restricted Band
5565.72								Done via Conducted
6493.34								Not in Restricted Band
6493.34								Done via Conducted
7420.96	57.85	V	73.97	-16.12	Peak	300.25	111.07	
7420.96	37.85	V	53.97	-16.12	Avg	300.25	111.07	
8348.58	48.84	V	73.97	-25.13	Peak	300.50	207.37	
8348.58	28.84	V	53.97	-25.13	Avg	300.50	207.37	
9276.2	45.83	V	73.97	-28.14	Peak	53.25	207.25	
9276.2	25.83	V	53.97	-28.14	Avg	53.25	207.25	

**FCC 15.247**

Mesa Labs, Inc.  
 VPx Sensor 900 MHz with LCD  
 Model: CM-000272

Date: 07/29/2016  
 Lab: D  
 Tested By: Kyle Fujimoto

**Battery Mode**  
**High Channel - Y-Axis**  
**Transmit Mode**

Freq. (MHz)	Level (dBuV/m)	Pol (v/h)	Limit	Margin	Peak / QP / Avg	Table Angle (deg)	Ant. Height (cm)	Comments
1855.24								Not in Restricted Band
1855.24								Done via Conducted
2782.86	50.71	V	73.97	-23.26	Peak	263.25	191.19	
2782.86	30.71	V	53.97	-23.26	Avg	263.25	191.19	
3710.48	44.78	V	73.97	-29.19	Peak	277.00	207.01	
3710.48	24.78	V	53.97	-29.19	Avg	277.00	207.01	
4638.1	53.35	V	73.97	-20.62	Peak	287.25	175.07	
4638.1	33.35	V	53.97	-20.62	Avg	287.25	175.07	
5565.72								Not in Restricted Band
5565.72								Done via Conducted
6493.34								Not in Restricted Band
6493.34								Done via Conducted
7420.96	59.45	V	73.97	-14.52	Peak	253.25	250.11	
7420.96	39.45	V	53.97	-14.52	Avg	253.25	250.11	
8348.58	49.02	V	73.97	-24.95	Peak	295.00	250.05	
8348.58	29.02	V	53.97	-24.95	Avg	295.00	250.05	
9276.2	45.64	V	73.97	-28.33	Peak	74.00	126.77	
9276.2	25.64	V	53.97	-28.33	Avg	74.00	126.77	

**FCC 15.247**

Mesa Labs, Inc.  
 VPx Sensor 900 MHz with LCD  
 Model: CM-000272

Date: 07/29/2016  
 Lab: D  
 Tested By: Kyle Fujimoto

**Battery Mode**  
**High Channel - X-Axis**  
**Transmit Mode**

Freq. (MHz)	Level (dBuV/m)	Pol (v/h)	Limit	Margin	Peak / QP / Avg	Table Angle (deg)	Ant. Height (cm)	Comments
1855.24								<b>Not in Restricted Band</b>
1855.24								<b>Done via Conducted</b>
2782.86	51.34	H	73.97	-22.63	Peak	223.50	143.25	
2782.86	31.34	H	53.97	-22.63	Avg	223.50	143.25	
3710.48	43.40	H	73.97	-30.57	Peak	226.50	126.89	
3710.48	23.40	H	53.97	-30.57	Avg	226.50	126.89	
4638.1	45.03	H	73.97	-28.94	Peak	245.25	175.37	
4638.1	25.03	H	53.97	-28.94	Avg	245.25	175.37	
5565.72								<b>Not in Restricted Band</b>
5565.72								<b>Done via Conducted</b>
6493.34								<b>Not in Restricted Band</b>
6493.34								<b>Done via Conducted</b>
7420.96	46.62	H	73.97	-27.35	Peak	102.00	159.13	
7420.96	26.62	H	53.97	-27.35	Avg	102.00	159.13	
8348.58	45.30	H	73.97	-28.67	Peak	83.50	174.83	
8348.58	25.30	H	53.97	-28.67	Avg	83.50	174.83	
9276.2	44.80	H	73.97	-29.17	Peak	140.50	239.31	
9276.2	24.80	H	53.97	-29.17	Avg	140.50	239.31	

**FCC 15.247**

Mesa Labs, Inc.  
 VPx Sensor 900 MHz with LCD  
 Model: CM-000272

Date: 07/29/2016  
 Lab: D  
 Tested By: Kyle Fujimoto

**Battery Mode**  
**High Channel - Y-Axis**  
**Transmit Mode**

Freq. (MHz)	Level (dBuV/m)	Pol (v/h)	Limit	Margin	Peak / QP / Avg	Table Angle (deg)	Ant. Height (cm)	Comments
1855.24								Not in Restricted Band
1855.24								Done via Conducted
2782.86	55.96	H	73.97	-18.01	Peak	255.25	222.89	
2782.86	35.96	H	53.97	-18.01	Avg	255.25	222.89	
3710.48	46.24	H	73.97	-27.73	Peak	261.25	175.07	
3710.48	26.24	H	53.97	-27.73	Avg	261.25	175.07	
4638.1	62.81	H	73.97	-11.16	Peak	1.00	207.19	
4638.1	42.81	H	53.97	-11.16	Avg	1.00	207.19	
5565.72								Not in Restricted Band
5565.72								Done via Conducted
6493.34								Not in Restricted Band
6493.34								Done via Conducted
7420.96	65.20	H	73.97	-8.77	Peak	301.25	159.01	
7420.96	45.20	H	53.97	-8.77	Avg	301.25	159.01	
8348.58	50.04	H	73.97	-23.93	Peak	303.50	110.77	
8348.58	30.04	H	53.97	-23.93	Avg	303.50	110.77	
9276.2	51.10	H	73.97	-22.87	Peak	297.50	127.13	
9276.2	31.10	H	53.97	-22.87	Avg	297.50	127.13	



**FCC 15.247**

Mesa Labs, Inc.  
 VPx Sensor 900 MHz with LCD  
 Model: CM-000272

Date: 07/29/2016

Lab: D

Tested By: Kyle Fujimoto

**Battery Mode**

**Non Harmonic Emissions from the Tx - 10 kHz to 30 MHz and 1 GHz to 9.3 GHz**  
**Digital Portion from the EUT - 10 kHz to 30 MHz and 1 GHz to 9.3 GHz**

Freq. (MHz)	Level (dBuV)	Pol (v/h)	Limit	Margin	Peak / QP / Avg	Ant. Height (m)	Table Angle (deg)	Comments
								No Emissions Detected from the Non Harmonic Emissions from the Tx
								10 kHz to 30 MHz
								No Emissions Detected from the Non Harmonic Emissions from the Tx
								1 GHz to 9.3 GHz
								No Emissions Detected from the Digital Portion of the EUT
								10 kHz to 30 MHz
								No Emissions Detected from the Digital Portion of the EUT
								1 GHz to 9.3 GHz
								Tested in both Horizontal and Vertical Polarizations

**FCC 15.247**

Mesa Labs, Inc.  
 VPx Sensor 900 MHz with LCD  
 Model: CM-000272

Date: 07/28/2016  
 Lab: D  
 Tested By: Kyle Fujimoto

**AC Power Mode**  
**Low Channel - X-Axis**  
**Transmit Mode**

Freq. (MHz)	Level (dBuV/m)	Pol (v/h)	Limit	Margin	Peak / QP / Avg	Table Angle (deg)	Ant. Height (cm)	Comments
1805.24								<b>Not in Restricted Band</b>
1805.24								<b>Done via Conducted</b>
2707.86	51.56	V	73.97	-22.41	Peak	259.00	126.83	
2707.86	31.56	V	53.97	-22.41	Avg	259.00	126.83	
3610.48	51.15	V	73.97	-22.82	Peak	84.25	111.37	
3610.48	31.15	V	53.97	-22.82	Avg	84.25	111.37	
4513.1	53.96	V	73.97	-20.01	Peak	72.25	127.01	
4513.1	33.96	V	53.97	-20.01	Avg	72.25	127.01	
5415.72	48.68	V	73.97	-25.29	Peak	101.50	111.25	
5415.72	28.68	V	53.97	-25.29	Avg	101.50	111.25	
6318.34								<b>Not in Restricted Band</b>
6318.34								<b>Done via Conducted</b>
7220.96								<b>Not in Restricted Band</b>
7220.96								<b>Done via Conducted</b>
8123.58	52.01	V	73.97	-21.96	Peak	351.00	111.07	
8123.58	32.01	V	53.97	-21.96	Avg	351.00	111.07	
9026.2	43.68	V	73.97	-30.29	Peak	35.00	206.77	
9026.2	23.68	V	53.97	-30.29	Avg	35.00	206.77	



**FCC 15.247**

Mesa Labs, Inc.  
 VPx Sensor 900 MHz with LCD  
 Model: CM-000272

Date: 07/28/2016  
 Lab: D  
 Tested By: Kyle Fujimoto

**AC Power Mode**  
**Low Channel - Y-Axis**  
**Transmit Mode**

Freq. (MHz)	Level (dBuV/m)	Pol (v/h)	Limit	Margin	Peak / QP / Avg	Table Angle (deg)	Ant. Height (cm)	Comments
1805.24								Not in Restricted Band
1805.24								Done via Conducted
2707.86	43.59	V	73.97	-30.38	Peak	102.00	223.07	
2707.86	23.59	V	53.97	-30.38	Avg	102.00	223.07	
3610.48	46.46	V	73.97	-27.51	Peak	137.75	175.19	
3610.48	26.46	V	53.97	-27.51	Avg	137.75	175.19	
4513.1	53.52	V	73.97	-20.45	Peak	150.75	143.01	
4513.1	33.52	V	53.97	-20.45	Avg	150.75	143.01	
5415.72	43.01	V	73.97	-30.96	Peak	177.00	222.95	
5415.72	23.01	V	53.97	-30.96	Avg	177.00	222.95	
6318.34								Not in Restricted Band
6318.34								Done via Conducted
7220.96								Not in Restricted Band
7220.96								Done via Conducted
8123.58	52.19	V	73.97	-21.78	Peak	169.00	222.95	
8123.58	32.19	V	53.97	-21.78	Avg	169.00	222.95	
9026.2	43.99	V	73.97	-29.98	Peak	129.00	158.83	
9026.2	22.99	V	53.97	-22.98	Avg	129.00	158.83	

**FCC 15.247**

Mesa Labs, Inc.  
 VPx Sensor 900 MHz with LCD  
 Model: CM-000272

Date: 07/28/2016  
 Lab: D  
 Tested By: Kyle Fujimoto

**AC Power Mode**  
**Low Channel - X-Axis**  
**Transmit Mode**

Freq. (MHz)	Level (dBuV/m)	Pol (v/h)	Limit	Margin	Peak / QP / Avg	Table Angle (deg)	Ant. Height (cm)	Comments
1805.24								Not in Restricted Band
1805.24								Done via Conducted
2707.86	35.67	H	73.97	-38.30	Peak	277.00	142.83	
2707.86	15.67	H	53.97	-38.30	Avg	277.00	142.83	
3610.48	42.57	H	73.97	-31.40	Peak	49.50	127.61	
3610.48	22.57	H	53.97	-31.40	Avg	49.50	127.61	
4513.1	44.95	H	73.97	-29.02	Peak	49.50	127.19	
4513.1	24.95	H	53.97	-29.02	Avg	49.50	127.19	
5415.72	41.87	H	73.97	-32.10	Peak	312.25	223.31	
5415.72	21.87	H	53.97	-32.10	Avg	312.25	223.31	
6318.34								Not in Restricted Band
6318.34								Done via Conducted
7220.96								Not in Restricted Band
7220.96								Done via Conducted
8123.58	50.43	H	73.97	-23.54	Peak	312.50	126.00	
8123.58	30.43	H	53.97	-23.54	Avg	312.50	126.00	
9026.2	43.52	H	73.97	-30.45	Peak	3.00	142.95	
9026.2	23.52	H	53.97	-30.45	Avg	3.00	142.95	

**FCC 15.247**

Mesa Labs, Inc.  
 VPx Sensor 900 MHz with LCD  
 Model: CM-000272

Date: 07/28/2016  
 Lab: D  
 Tested By: Kyle Fujimoto

**AC Power Mode**  
**Low Channel - Y-Axis**  
**Transmit Mode**

Freq. (MHz)	Level (dBuV/m)	Pol (v/h)	Limit	Margin	Peak / QP / Avg	Table Angle (deg)	Ant. Height (cm)	Comments
1805.24								Not in Restricted Band
1805.24								Done via Conducted
2707.86	50.87	H	73.97	-23.10	Peak	115.25	111.19	
2707.86	30.87	H	53.97	-23.10	Avg	115.25	111.19	
3610.48	48.06	H	73.97	-25.91	Peak	150.25	142.00	
3610.48	28.06	H	53.97	-25.91	Avg	150.25	142.00	
4513.1	55.95	H	73.97	-18.02	Peak	151.25	110.95	
4513.1	35.95	H	53.97	-18.02	Avg	151.25	110.95	
5415.72	52.11	H	73.97	-21.86	Peak	201.00	158.89	
5415.72	32.11	H	53.97	-21.86	Avg	201.00	158.89	
6318.34								Not in Restricted Band
6318.34								Done via Conducted
7220.96								Not in Restricted Band
7220.96								Done via Conducted
8123.58	57.16	H	73.97	-16.81	Peak	176.25	110.89	
8123.58	37.16	H	53.97	-16.81	Avg	176.25	110.89	
9026.2	50.54	H	73.97	-23.43	Peak	195.75	174.95	
9026.2	30.54	H	53.97	-23.43	Avg	195.75	174.95	

**FCC 15.247**

Mesa Labs, Inc.  
 VPx Sensor 900 MHz with LCD  
 Model: CM-000272

Date: 07/28/2016  
 Lab: D  
 Tested By: Kyle Fujimoto

**AC Power Mode**  
**Middle Channel - X-Axis**  
**Transmit Mode**

Freq. (MHz)	Level (dBuV/m)	Pol (v/h)	Limit	Margin	Peak / QP / Avg	Table Angle (deg)	Ant. Height (cm)	Comments
1830.24								Not in Restricted Band
1830.24								Done via Conducted
2745.36	47.89	V	73.97	-26.08	Peak	73.25	110.95	
2745.36	27.89	V	53.97	-26.08	Avg	73.25	110.95	
3660.48	48.82	V	73.97	-25.15	Peak	70.75	111.13	
3660.48	28.82	V	53.97	-25.15	Avg	70.75	111.13	
4575.6	48.82	V	73.97	-25.15	Peak	71.75	111.13	
4575.6	28.82	V	53.97	-25.15	Avg	71.75	111.13	
5490.72								Not in Restricted Band
5490.72								Done via Conducted
6405.84								Not in Restricted Band
6405.84								Done via Conducted
7320.96	59.56	V	73.97	-14.41	Peak	54.25	249.94	
7320.96	39.56	V	53.97	-14.41	Avg	54.25	249.94	
8236.08	47.76	V	73.97	-26.21	Peak	131.75	100.00	
8236.08	27.76	V	53.97	-26.21	Avg	131.75	100.00	
9151.2	43.64	V	73.97	-30.33	Peak	110.25	175.07	
9151.2	23.64	V	53.97	-30.33	Avg	110.25	175.07	

**FCC 15.247**

Mesa Labs, Inc.  
 VPx Sensor 900 MHz with LCD  
 Model: CM-000272

Date: 07/28/2016  
 Lab: D  
 Tested By: Kyle Fujimoto

**AC Power Mode**  
**Middle Channel - Y-Axis**  
**Transmit Mode**

Freq. (MHz)	Level (dBuV/m)	Pol (v/h)	Limit	Margin	Peak / QP / Avg	Table Angle (deg)	Ant. Height (cm)	Comments
1830.24								Not in Restricted Band
1830.24								Done via Conducted
2745.36	47.74	V	73.97	-26.23	Peak	279.25	100.01	
2745.36	27.74	V	53.97	-26.23	Avg	279.25	100.01	
3660.48	46.66	V	73.97	-27.31	Peak	21.25	191.07	
3660.48	26.66	V	53.97	-27.31	Avg	21.25	191.07	
4575.6	54.89	V	73.97	-19.08	Peak	340.25	159.25	
4575.6	34.89	V	53.97	-19.08	Avg	340.25	159.25	
5490.72								Not in Restricted Band
5490.72								Done via Conducted
6405.84								Not in Restricted Band
6405.84								Done via Conducted
7320.96	52.50	V	73.97	-21.47	Peak	194.00	127.13	
7320.96	32.50	V	53.97	-21.47	Avg	194.00	127.13	
8236.08	45.48	V	73.97	-28.49	Peak	7.25	175.25	
8236.08	25.48	V	53.97	-28.49	Avg	7.25	175.25	
9151.2	43.86	V	73.97	-30.11	Peak	156.25	222.95	
9151.2	23.86	V	53.97	-30.11	Avg	156.25	222.95	

**FCC 15.247**

Mesa Labs, Inc.  
 VPx Sensor 900 MHz with LCD  
 Model: CM-000272

Date: 07/28/2016  
 Lab: D  
 Tested By: Kyle Fujimoto

**AC Power Mode**  
**Middle Channel - X-Axis**  
**Transmit Mode**

Freq. (MHz)	Level (dBuV/m)	Pol (v/h)	Limit	Margin	Peak / QP / Avg	Table Angle (deg)	Ant. Height (cm)	Comments
1830.24								Not in Restricted Band
1830.24								Done via Conducted
2745.36	43.58	H	73.97	-30.39	Peak	254.25	250.00	
2745.36	23.58	H	53.97	-30.39	Avg	254.25	250.00	
3660.48	42.41	H	73.97	-31.56	Peak	289.00	111.25	
3660.48	22.41	H	53.97	-31.56	Avg	289.00	111.25	
4575.6	44.90	H	73.97	-29.07	Peak	221.00	250.00	
4575.6	24.90	H	53.97	-29.07	Avg	221.00	250.00	
5490.72								Not in Restricted Band
5490.72								Done via Conducted
6405.84								Not in Restricted Band
6405.84								Done via Conducted
7320.96	47.19	H	73.97	-26.78	Peak	185.00	126.83	
7320.96	27.19	H	53.97	-26.78	Avg	185.00	126.83	
8236.08	46.62	H	73.97	-27.35	Peak	175.75	111.13	
8236.08	26.62	H	53.97	-27.35	Avg	175.75	111.13	
9151.2	43.55	H	73.97	-30.42	Peak	272.75	127.31	
9151.2	23.55	H	53.97	-30.42	Avg	272.75	127.31	

**FCC 15.247**

Mesa Labs, Inc.  
 VPx Sensor 900 MHz with LCD  
 Model: CM-000272

Date: 07/28/2016  
 Lab: D  
 Tested By: Kyle Fujimoto

**AC Power Mode**  
**Middle Channel - Y-Axis**  
**Transmit Mode**

Freq. (MHz)	Level (dBuV/m)	Pol (v/h)	Limit	Margin	Peak / QP / Avg	Table Angle (deg)	Ant. Height (cm)	Comments
1830.24								Not in Restricted Band
1830.24								Done via Conducted
2745.36	51.01	H	73.97	-22.96	Peak	284.25	175.01	
2745.36	31.01	H	53.97	-22.96	Avg	284.25	175.01	
3660.48	43.23	H	73.97	-30.74	Peak	295.00	250.00	
3660.48	23.23	H	53.97	-30.74	Avg	295.00	250.00	
4575.6	53.62	H	73.97	-20.35	Peak	12.00	111.07	
4575.6	33.62	H	53.97	-20.35	Avg	12.00	111.07	
5490.72								Not in Restricted Band
5490.72								Done via Conducted
6405.84								Not in Restricted Band
6405.84								Done via Conducted
7320.96	69.07	H	73.97	-4.90	Peak	359.50	126.89	
7320.96	49.07	H	53.97	-4.90	Avg	359.50	126.89	
8236.08	53.23	H	73.97	-20.74	Peak	10.25	111.31	
8236.08	33.23	H	53.97	-20.74	Avg	10.25	111.31	
9151.2	47.38	H	73.97	-26.59	Peak	343.50	223.25	
9151.2	27.38	H	53.97	-26.59	Avg	343.50	223.25	



**FCC 15.247**

Mesa Labs, Inc.  
 VPx Sensor 900 MHz with LCD  
 Model: CM-000272

Date: 07/29/2016  
 Lab: D  
 Tested By: Kyle Fujimoto

**AC Power Mode**  
**High Channel - X-Axis**  
**Transmit Mode**

Freq. (MHz)	Level (dBuV/m)	Pol (v/h)	Limit	Margin	Peak / QP / Avg	Table Angle (deg)	Ant. Height (cm)	Comments
1855.24								Not in Restricted Band
1855.24								Done via Conducted
2782.86	53.40	V	73.97	-20.57	Peak	0.50	223.01	
2782.86	33.40	V	53.97	-20.57	Avg	0.50	223.01	
3710.48	45.08	V	73.97	-28.89	Peak	272.75	175.07	
3710.48	25.08	V	53.97	-28.89	Avg	272.75	175.07	
4638.1	61.18	V	73.97	-12.79	Peak	0.25	222.53	
4638.1	41.18	V	53.97	-12.79	Avg	0.25	222.53	
5565.72								Not in Restricted Band
5565.72								Done via Conducted
6493.34								Not in Restricted Band
6493.34								Done via Conducted
7420.96	66.31	V	73.97	-7.66	Peak	311.25	126.83	
7420.96	46.31	V	53.97	-7.66	Avg	311.25	126.83	
8348.58	50.23	V	73.97	-23.74	Peak	292.25	111.13	
8348.58	30.23	V	53.97	-23.74	Avg	292.25	111.13	
9276.2	51.41	V	73.97	-22.56	Peak	287.00	127.01	
9276.2	31.41	V	53.97	-22.56	Avg	287.00	127.01	

**FCC 15.247**

Mesa Labs, Inc.  
 VPx Sensor 900 MHz with LCD  
 Model: CM-000272

Date: 07/29/2016  
 Lab: D  
 Tested By: Kyle Fujimoto

**AC Power Mode**  
**High Channel - Y-Axis**  
**Transmit Mode**

Freq. (MHz)	Level (dBuV/m)	Pol (v/h)	Limit	Margin	Peak / QP / Avg	Table Angle (deg)	Ant. Height (cm)	Comments
1855.24								Not in Restricted Band
1855.24								Done via Conducted
2782.86	52.84	V	73.97	-21.13	Peak	339.25	159.01	
2782.86	32.84	V	53.97	-21.13	Avg	339.25	159.01	
3710.48	43.88	V	73.97	-30.09	Peak	271.50	250.11	
3710.48	23.88	V	53.97	-30.09	Avg	271.50	250.11	
4638.1	55.00	V	73.97	-18.97	Peak	298.00	191.31	
4638.1	35.00	V	53.97	-18.97	Avg	298.00	191.31	
5565.72								Not in Restricted Band
5565.72								Done via Conducted
6493.34								Not in Restricted Band
6493.34								Done via Conducted
7420.96	54.26	V	73.97	-19.71	Peak	305.75	249.94	
7420.96	34.26	V	53.97	-19.71	Avg	305.75	249.94	
8348.58	45.79	V	73.97	-28.18	Peak	287.50	223.49	
8348.58	25.79	V	53.97	-28.18	Avg	287.50	223.49	
9276.2	45.13	V	73.97	-28.84	Peak	194.75	191.49	
9276.2	25.13	V	53.97	-28.84	Avg	194.75	191.49	

**FCC 15.247**

Mesa Labs, Inc.  
 VPx Sensor 900 MHz with LCD  
 Model: CM-000272

Date: 07/29/2016  
 Lab: D  
 Tested By: Kyle Fujimoto

**AC Power Mode**  
**High Channel - X-Axis**  
**Transmit Mode**

Freq. (MHz)	Level (dBuV/m)	Pol (v/h)	Limit	Margin	Peak / QP / Avg	Table Angle (deg)	Ant. Height (cm)	Comments
1855.24								Not in Restricted Band
1855.24								Done via Conducted
2782.86	48.54	H	73.97	-25.43	Peak	202.00	250.17	
2782.86	28.54	H	53.97	-25.43	Avg	202.00	250.17	
3710.48	41.89	H	73.97	-32.08	Peak	221.50	111.13	
3710.48	21.89	H	53.97	-32.08	Avg	221.50	111.13	
4638.1	46.22	H	73.97	-27.75	Peak	295.00	127.13	
4638.1	26.22	H	53.97	-27.75	Avg	295.50	127.13	
5565.72								Not in Restricted Band
5565.72								Done via Conducted
6493.34								Not in Restricted Band
6493.34								Done via Conducted
7420.96	50.80	H	73.97	-23.17	Peak	279.50	159.25	
7420.96	30.80	H	53.97	-23.17	Avg	279.50	159.25	
8348.58	49.34	H	73.97	-24.63	Peak	280.25	110.41	
8348.58	29.34	H	53.97	-24.63	Avg	280.25	110.41	
9276.2	45.31	H	73.97	-28.66	Peak	300.75	239.01	
9276.2	25.31	H	53.97	-28.66	Avg	300.75	239.01	

**FCC 15.247**

Mesa Labs, Inc.  
 VPx Sensor 900 MHz with LCD  
 Model: CM-000272

Date: 07/29/2016  
 Lab: D  
 Tested By: Kyle Fujimoto

**AC Power Mode**  
**High Channel - Y-Axis**  
**Transmit Mode**

Freq. (MHz)	Level (dBuV/m)	Pol (v/h)	Limit	Margin	Peak / QP / Avg	Table Angle (deg)	Ant. Height (cm)	Comments
1855.24								Not in Restricted Band
1855.24								Done via Conducted
2782.86	52.99	H	73.97	-20.98	Peak	359.75	191.37	
2782.86	32.99	H	53.97	-20.98	Avg	359.75	191.37	
3710.48	48.83	H	73.97	-25.14	Peak	24.50	208.20	
3710.48	28.83	H	53.97	-25.14	Avg	24.50	208.20	
4638.1	62.46	H	73.97	-11.51	Peak	358.00	239.19	
4638.1	42.46	H	53.97	-11.51	Avg	358.00	239.19	
5565.72								Not in Restricted Band
5565.72								Done via Conducted
6493.34								Not in Restricted Band
6493.34								Done via Conducted
7420.96	65.44	H	73.97	-8.53	Peak	303.50	110.77	
7420.96	45.44	H	53.97	-8.53	Avg	303.50	110.77	
8348.58	51.50	H	73.97	-22.47	Peak	332.75	143.49	
8348.58	31.50	H	53.97	-22.47	Avg	332.75	143.49	
9276.2	49.42	H	73.97	-24.55	Peak	289.50	190.77	
9276.2	29.42	H	53.97	-24.55	Avg	289.50	190.77	



**FCC 15.247**

Mesa Labs, Inc.  
 VPx Sensor 900 MHz with LCD  
 Model: CM-000272

Date: 07/29/2016  
 Lab: D  
 Tested By: Kyle Fujimoto

**AC Power Mode**

**Non Harmonic Emissions from the Tx - 10 kHz to 30 MHz and 1 GHz to 9.3 GHz**  
**Digital Portion from the EUT - 10 kHz to 30 MHz and 1 GHz to 9.3 GHz**

Freq. (MHz)	Level (dBuV)	Pol (v/h)	Limit	Margin	Peak / QP / Avg	Ant. Height (m)	Table Angle (deg)	Comments
								No Emissions Detected from the Non Harmonic Emissions from the Tx
								10 kHz to 30 MHz
								No Emissions Detected from the Non Harmonic Emissions from the Tx
								1 GHz to 9.3 GHz
								No Emissions Detected from the Digital Portion of the EUT
								10 kHz to 30 MHz
								No Emissions Detected from the Digital Portion of the EUT
								1 GHz to 9.3 GHz
								Tested in both Horizontal and Vertical Polarizations

Title: Pre-Scan - FCC Class B  
 File: 1 - Agilent - Pre-Scan - AC Power Mode - Tx Mode - FCC Class B.set  
 Operator: Kyle Fujimoto  
 EUT Type: VPx Sensor 900 MHz with LCD  
 EUT Condition: The EUT is continuously transmitting at the middle channel, worst case  
 Comments: Company: Mesa Labs, Inc.  
 Model: CM-000272  
 AC Power Mode  
 S/N: 52000001

7/28/2016 9:00:03 AM  
 Sequence: Preliminary Scan

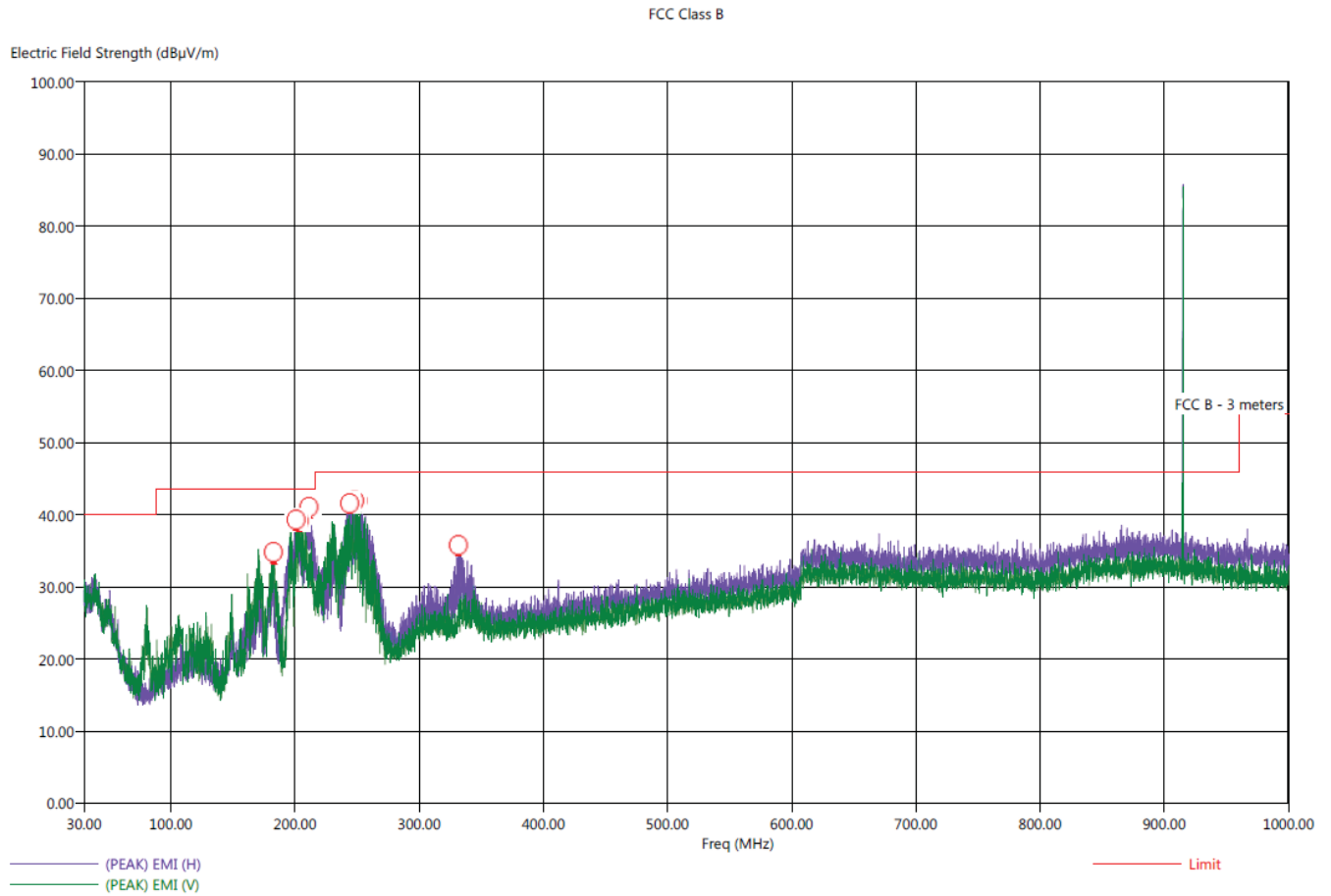

Note: The emission above the limit line is from the transmitter and subject to FCC 15.247 limits.



Title: Radiated Final - FCC Class B  
 File: 1 - Agilent - Final Scan - AC Power Mode - Tx Mode - FCC Class B.set  
 Operator: Kyle Fujimoto  
 EUT Type: VPx Sensor 900 MHz with LCD  
 EUT Condition: The EUT is continuously transmitting at the middle channel, worst case  
 Comments: Company: Mesa Labs, Inc.  
 Model: CM-000272  
 AC Power Mode  
 S/N: 52000001

7/28/2016 9:58:50 AM  
 Sequence: Final Measurements

FCC Class B										
Freq (MHz)	Pol	(PEAK) EMI (dBµV/m)	(OP) EMI (dBµV/m)	(PEAK) Margin (dB)	(QP) Margin (dB)	Limit (dBµV/m)	Transducer (dB)	Cable (dB)	Ttbl Aql (dea)	Twr Ht (cm)
182.70	V	36.91	32.83	-6.59	-10.67	43.50	14.11	1.02	214.25	127.25
183.40	V	36.51	32.04	-6.99	-11.46	43.50	14.07	1.02	202.50	127.37
200.90	V	39.68	35.62	-3.82	-7.88	43.50	13.05	1.09	267.00	111.43
203.30	V	36.69	32.34	-6.81	-11.16	43.50	13.17	1.11	272.50	144.26
211.30	H	41.08	37.43	-2.42	-6.07	43.50	13.57	1.14	177.00	239.31
212.00	H	40.63	36.75	-2.87	-6.75	43.50	13.60	1.14	174.75	127.37
243.10	H	42.15	37.82	-3.85	-8.18	46.00	15.01	1.23	166.25	159.37
244.00	V	41.46	37.67	-4.54	-8.33	46.00	15.05	1.23	110.00	127.37
245.50	H	39.98	36.18	-6.02	-9.82	46.00	15.11	1.23	165.00	255.37
246.40	H	41.94	38.12	-4.06	-7.88	46.00	15.15	1.23	163.50	223.07
248.00	V	44.52	40.59	-1.48	-5.41	46.00	15.21	1.24	110.25	111.07
249.00	V	39.50	35.16	-6.50	-10.84	46.00	15.25	1.24	97.50	142.95
250.50	V	34.02	29.57	-11.98	-16.43	46.00	15.32	1.24	103.75	319.43
331.60	H	33.51	27.77	-12.49	-18.23	46.00	18.01	1.43	183.50	158.89
332.40	H	34.98	29.99	-11.02	-16.01	46.00	18.00	1.43	36.00	160.02



Title: Pre-Scan - FCC Class B  
 File: 2 - Agilent - Pre-Scan - AC Power Mode - Rx Mode - FCC Class B.set  
 Operator: Kyle Fujimoto  
 EUT Type: VPx Sensor 900 MHz with LCD  
 EUT Condition: The EUT is continuously receiving at middle channel, worst case  
 Comments: Company: Mesa Labs, Inc.  
 Model: CM-000272  
 AC Power Mode  
 S/N: 52000001

7/28/2016 11:56:32 AM  
 Sequence: Preliminary Scan

FCC Class B

Electric Field Strength (dB $\mu$ V/m)

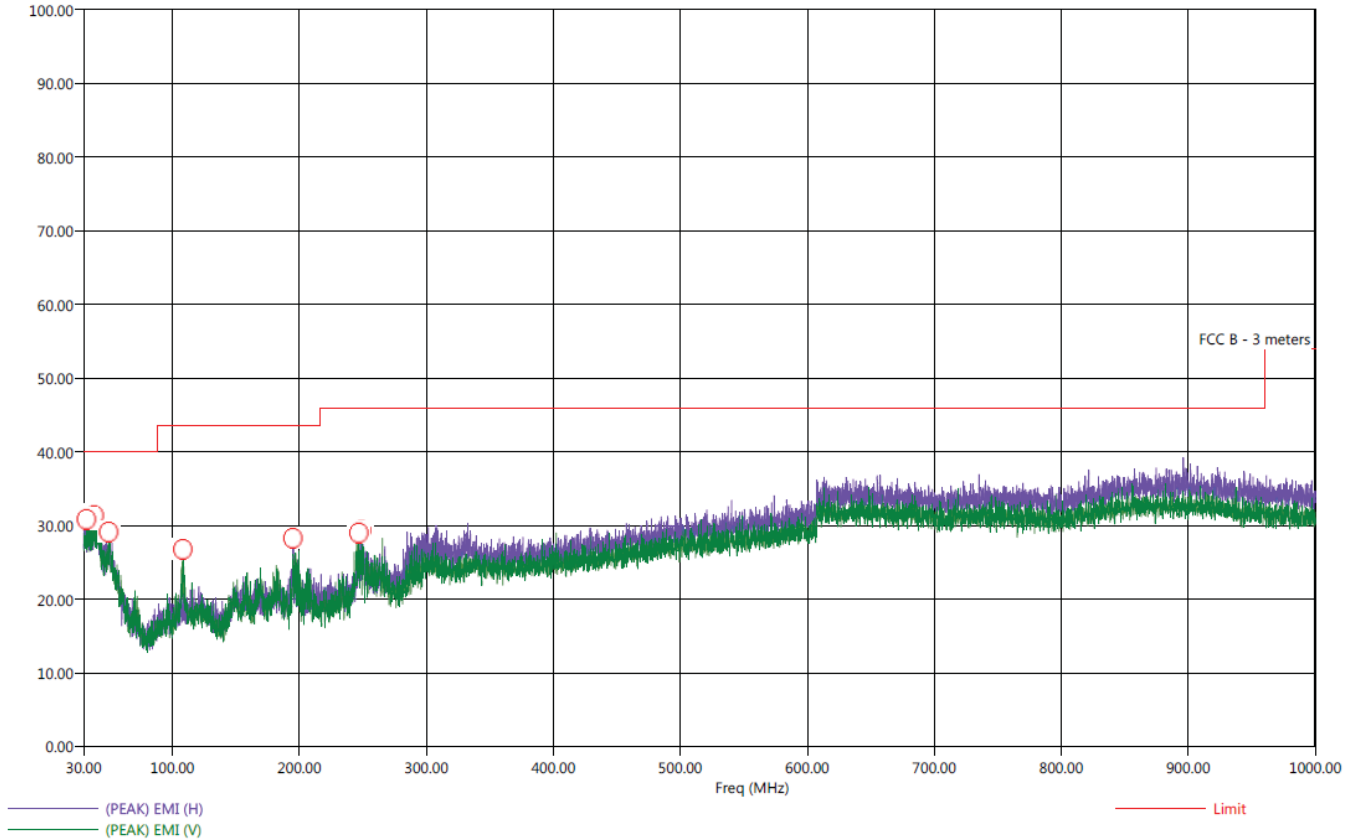

Title: Radiated Final - FCC Class B  
 File: 2 - Agilent - Final Scan - AC Power Mode - Rx Mode - FCC Class B.set  
 Operator: Kyle Fujimoto  
 EUT Type: VPx Sensor 900 MHz with LCD  
 EUT Condition: The EUT is continuously receiving at the middle channel, worst case  
 Comments: Company: Mesa Labs, Inc.  
 Model: CM-000272  
 AC Power Mode  
 S/N: 52000001

7/28/2016 12:09:29 PM  
 Sequence: Final Measurements

FCC Class B

Freq (MHz)	Pol	(PEAK) EMI (dB $\mu$ V/m)	(QP) EMI (dB $\mu$ V/m)	(PEAK) Margin (dB)	(QP) Margin (dB)	Limit (dB $\mu$ V/m)	Transducer (dB)	Cable (dB)	Ttbl Aql (deq)	Twr Ht (cm)
32.20	V	31.78	26.70	-8.22	-13.30	40.00	24.15	0.36	130.00	303.31
38.50	H	33.09	27.36	-6.91	-12.64	40.00	25.05	0.38	54.75	143.19
49.90	V	30.28	25.28	-9.72	-14.72	40.00	22.39	0.42	354.75	271.07
108.30	V	29.62	24.00	-13.88	-19.50	43.50	14.50	0.80	248.50	111.25
194.90	H	35.27	24.68	-8.23	-18.82	43.50	13.32	1.07	177.75	207.43
246.90	V	34.50	23.97	-11.50	-22.03	46.00	15.16	1.23	70.25	271.67
248.90	V	32.12	25.00	-13.88	-21.00	46.00	15.25	1.24	50.75	111.13
249.30	V	31.26	23.70	-14.74	-22.30	46.00	15.27	1.24	55.75	287.31



Title: Pre-Scan - FCC Class B  
 File: 3 - Agilent - Pre-Scan - Battery Mode - Tx Mode - FCC Class B.set  
 Operator: Kyle Fujimoto  
 EUT Type: VPx Sensor 900 MHz with LCD  
 EUT Condition: The EUT is continuously transmitting at the low channel, worst case  
 Comments: Company: Mesa Labs, Inc.  
 Model: CM-000272  
 Battery Mode  
 S/N: 52000001

7/28/2016 10:39:44 AM  
 Sequence: Preliminary Scan

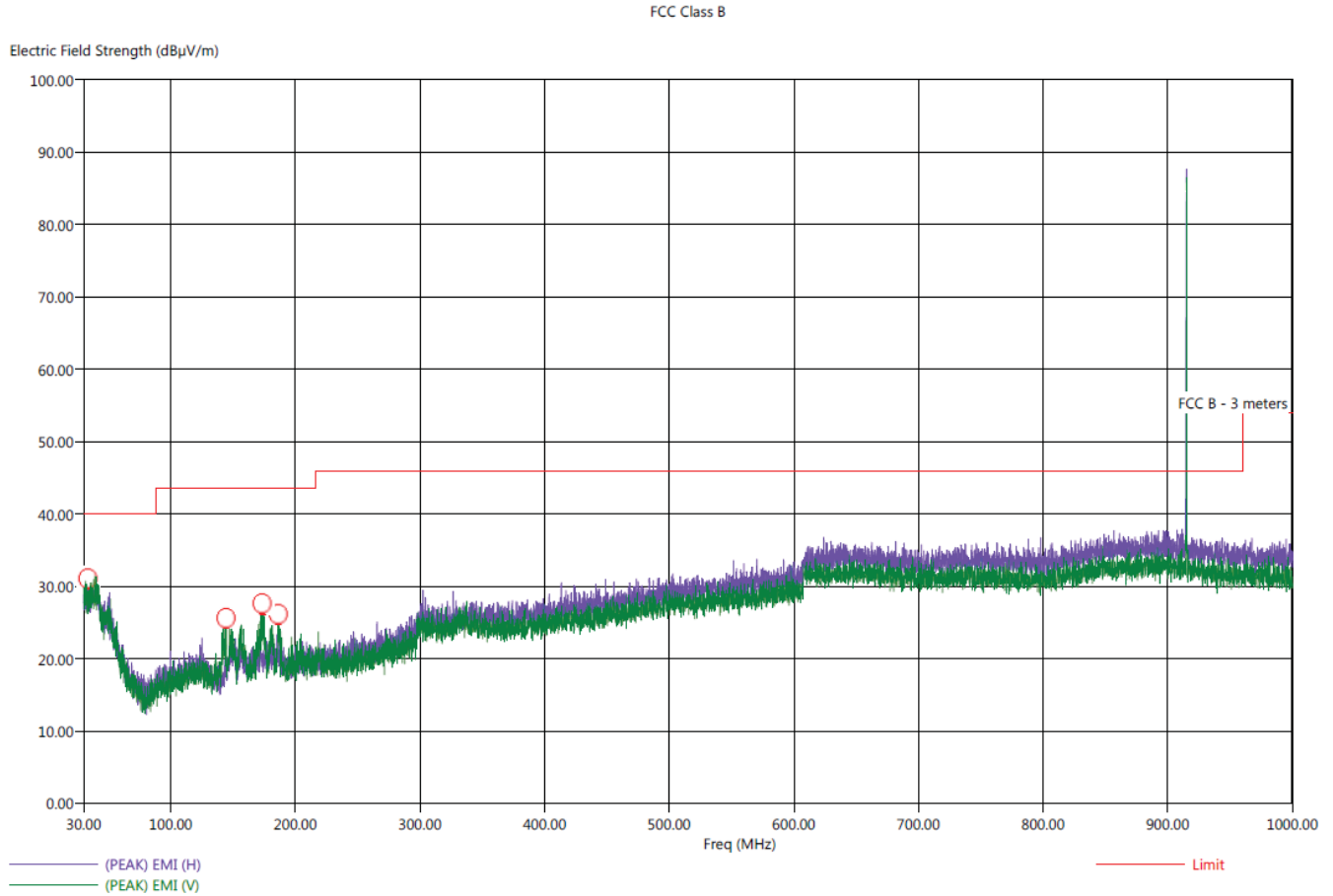

Note: The emission above the limit line is from the transmitter and subject of FCC 15.247 limits.

Title: Radiated Final - FCC Class B  
 File: 3 - Agilent - Final Scan - Battery Mode - Tx Mode - FCC Class B.set  
 Operator: Kyle Fujimoto  
 EUT Type: VPx Sensor 900 MHz with LCD  
 EUT Condition: The EUT is continuously transmitting at the low channel, worst case  
 Comments: Company: Mesa Labs, Inc.  
 Model: CM-000272  
 Battery Mode  
 S/N: 52000001

7/28/2016 10:50:17 AM  
 Sequence: Final Measurements

FCC Class B

Freq (MHz)	Pol	(PEAK) EMI (dBμV/m)	(OP) EMI (dBμV/m)	(PEAK) Margin (dB)	(QP) Margin (dB)	Limit (dBμV/m)	Transducer (dB)	Cable (dB)	Ttbl Aql (deq)	Twr Ht (cm)
33.50	H	31.87	26.64	-8.13	-13.36	40.00	24.21	0.36	271.75	159.37
34.80	H	31.81	26.55	-8.19	-13.45	40.00	24.29	0.37	209.25	159.25
144.40	V	29.33	25.27	-14.17	-18.23	43.50	14.96	0.88	112.75	127.43
173.30	V	30.36	25.77	-13.14	-17.73	43.50	14.10	0.98	208.75	111.25
174.00	V	28.65	22.36	-14.85	-21.14	43.50	14.13	0.99	126.00	143.13
186.40	V	27.04	21.16	-16.46	-22.34	43.50	13.88	1.04	197.25	191.19



Title: Pre-Scan - FCC Class B  
 File: 4 - Agilent - Pre-Scan - Battery Mode - Rx Mode - FCC Class B.set  
 Operator: Kyle Fujimoto  
 EUT Type: VPx Sensor 900 MHz with LCD  
 EUT Condition: The EUT is continuously receiving at low channel, worst case  
 Comments: Company: Mesa Labs, Inc.  
 Model: CM-000272  
 Battery Mode  
 S/N: 52000001

7/28/2016 11:11:47 AM  
 Sequence: Preliminary Scan

FCC Class B

Electric Field Strength (dBμV/m)

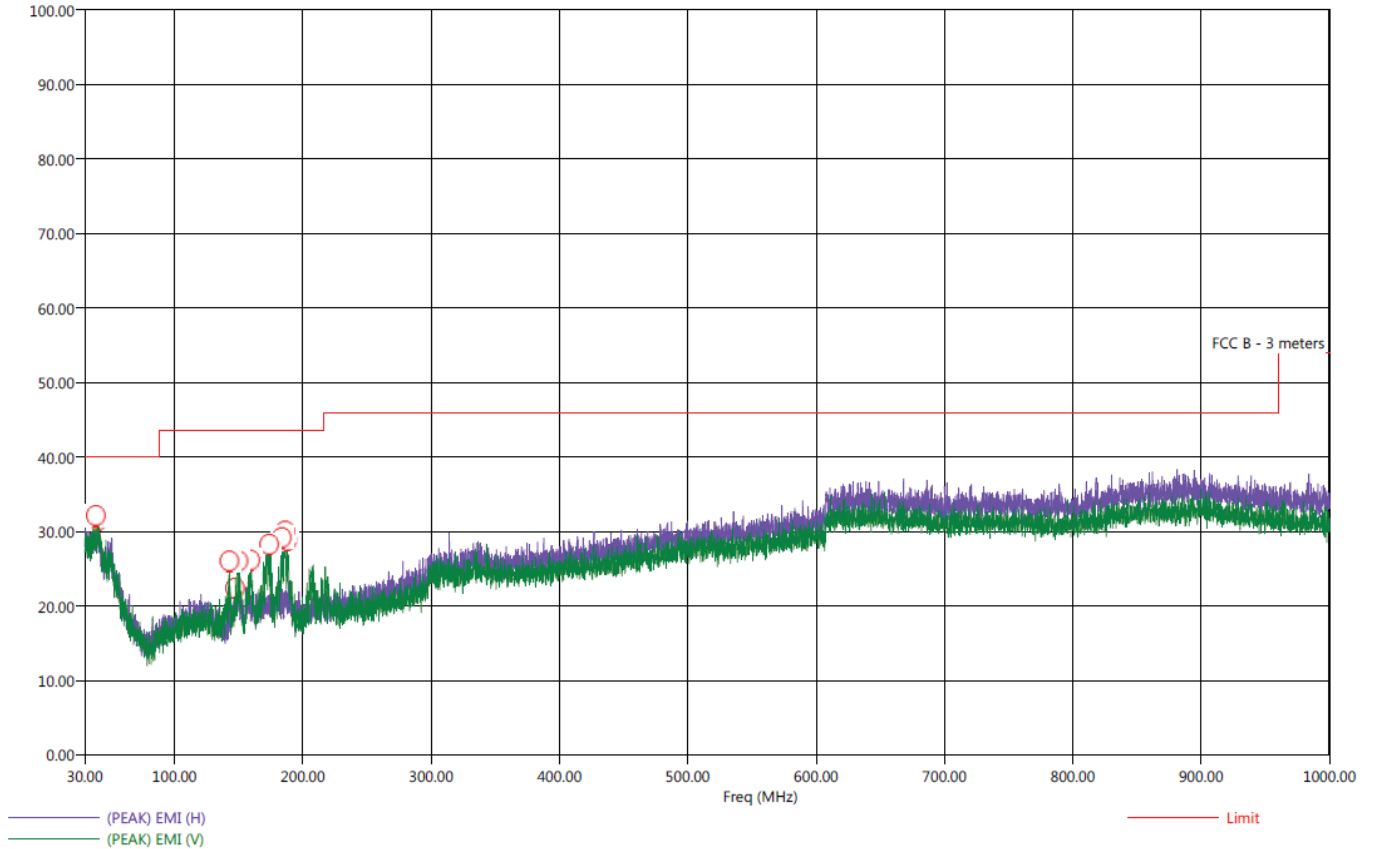

Title: Radiated Final - FCC Class B  
 File: 4 - Agilent - Final Scan - Battery Mode - Rx Mode - FCC Class B.set  
 Operator: Kyle Fujimoto  
 EUT Type: VPx Sensor 900 MHz with LCD  
 EUT Condition: The EUT is continuously receiving at low channel, worst case  
 Comments: Company: Mesa Labs, Inc.  
 Model: CM-000272  
 Battery Mode  
 S/N: 52000001

7/28/2016 11:20:30 AM  
 Sequence: Final Measurements

FCC Class B

Freq (MHz)	Pol	(PEAK) EMI (dBµV/m)	(OP) EMI (dBµV/m)	(PEAK) Margin (dB)	(QP) Margin (dB)	Limit (dBµV/m)	Transducer (dB)	Cable (dB)	Ttbl Aql (deq)	Twr Ht (cm)
38.70	V	32.40	27.56	-7.60	-12.44	40.00	25.17	0.39	259.50	383.43
40.60	H	32.88	27.20	-7.12	-12.80	40.00	24.92	0.39	296.00	223.25
142.80	V	27.50	21.71	-16.00	-21.79	43.50	14.19	0.87	107.25	126.59
147.20	H	22.53	17.52	-20.97	-25.98	43.50	16.16	0.89	114.00	287.85
149.90	V	28.74	23.42	-14.76	-20.08	43.50	17.09	0.90	64.00	143.91
159.10	V	30.50	24.47	-13.00	-19.03	43.50	13.58	0.93	70.50	111.19
173.90	V	28.85	24.37	-14.65	-19.13	43.50	14.12	0.99	352.00	111.31
183.60	V	31.09	26.17	-12.41	-17.33	43.50	14.06	1.03	234.50	111.07
186.40	V	31.03	26.56	-12.47	-16.94	43.50	13.87	1.04	265.25	111.31
187.70	V	31.94	24.81	-11.56	-18.69	43.50	13.80	1.04	212.25	111.07







***CONDUCTED EMISSIONS  
DATA SHEETS***

Title: FCC Class B - Conducted Emissions - Black Lead  
 File: Agilent - Conducted - Pre-Test - Line - VPx Sensor - Tx Mode - FCC Class B.set  
 Operator: Kyle Fujimoto  
 EUT Type: VPx Sensor 900 MHz with LCD  
 EUT Condition: The EUT was continuously frequency hopping  
 Comments: Company: Mesa Labs, Inc.  
 Model: CM-000272  
 S/N: 52000001

7/27/2016 9:16:38 AM  
 Sequence: Preliminary Scan

FCC Class B - Conducted Emissions - Black Lead

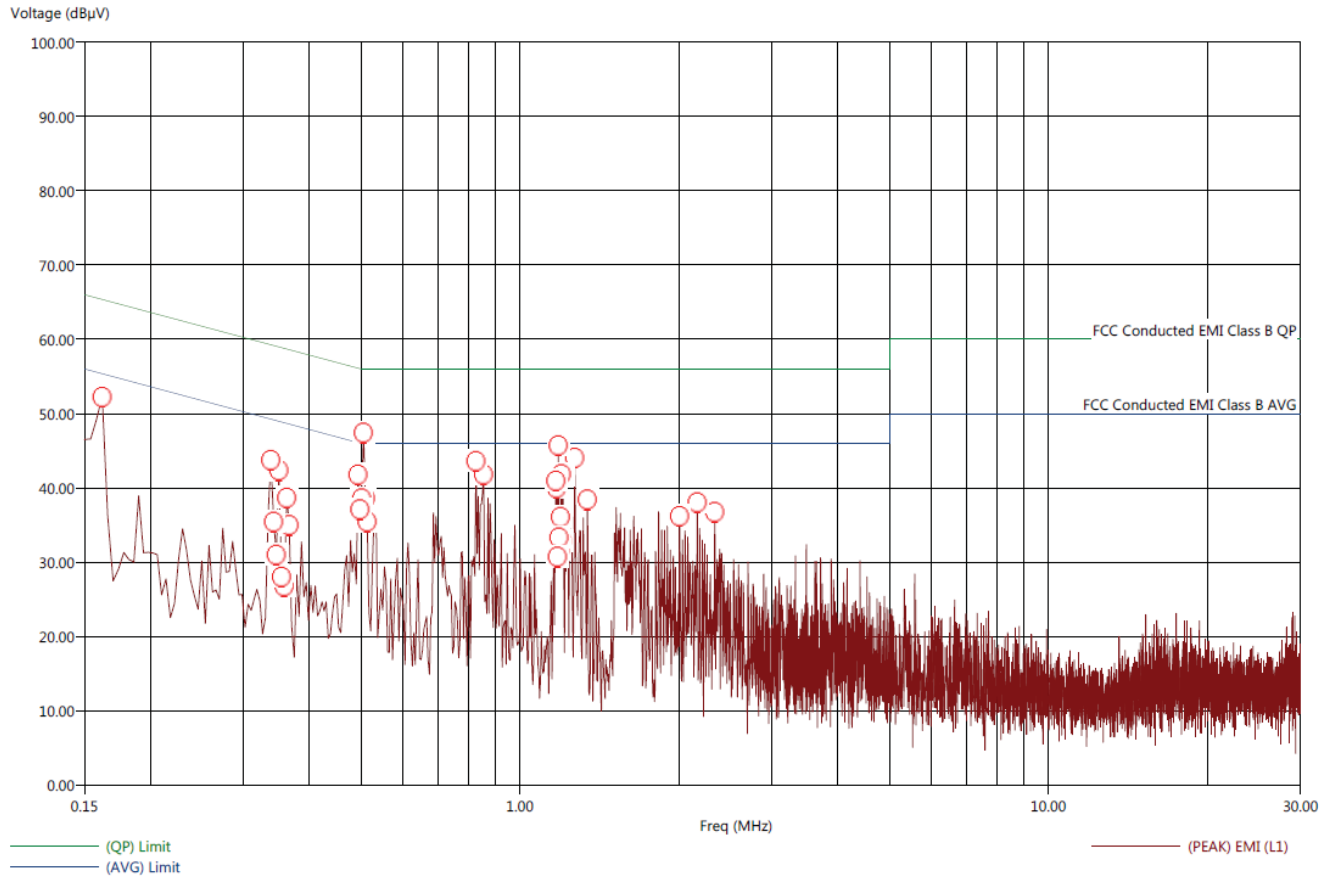

Title: FCC Class B - Conducted Emissions - Black Lead  
 File: Agilent - Conducted - Final Test - Line - VPx Sensor - Tx Mode - FCC Class B.set  
 Operator: Kyle Fujimoto  
 EUT Type: VPx Sensor 900 MHz with LCD  
 EUT Condition: The EUT was continuously frequency hopping  
 Comments: Company: Mesa Labs, Inc.  
 Model: CM-000272  
 S/N: 52000001

7/27/2016 9:24:50 AM  
 Sequence: Final Measurements

FCC Class B - Conducted Emissions - Black Lead

Freq (MHz)	(PEAK) EMI (dBµV)	(AVG) EMI (dBµV)	(PEAK) Margin AVL (dB)	(AVG) Margin AVL (dB)	(AVG) Limit (dBµV)	Cable (dB)	Transducer (dB)	Filter (dB)
0.162	57.86	41.73	2.92	-13.21	54.94	0.07	0.44	9.83
0.338	51.67	36.68	2.50	-12.49	49.17	0.08	0.05	9.84
0.342	51.97	37.99	2.81	-11.17	49.16	0.08	0.05	9.84
0.346	51.78	36.86	2.50	-12.42	49.28	0.08	0.06	9.84
0.350	51.87	36.68	2.73	-12.46	49.14	0.08	0.05	9.84
0.354	49.56	35.69	0.57	-13.30	48.98	0.08	0.04	9.84
0.358	52.22	36.57	3.08	-12.57	49.13	0.08	0.05	9.84
0.362	47.50	33.02	-1.40	-15.88	48.90	0.08	0.04	9.84
0.366	47.20	32.64	-1.67	-16.23	48.87	0.08	0.04	9.84
0.494	45.93	28.63	-0.23	-17.53	46.16	0.08	0.05	9.84
0.498	46.30	30.36	0.24	-15.70	46.06	0.08	0.05	9.84
0.502	46.85	31.30	0.85	-14.70	46.00	0.08	0.05	9.84
0.506	47.29	32.32	1.29	-13.68	46.00	0.08	0.05	9.84
0.510	47.15	31.37	1.15	-14.63	46.00	0.08	0.05	9.84
0.514	46.74	31.07	0.74	-14.93	46.00	0.08	0.05	9.84
0.826	44.70	26.48	-1.30	-19.52	46.00	0.10	0.04	9.84
0.854	44.29	28.75	-1.71	-17.25	46.00	0.10	0.04	9.84
1.170	47.22	31.14	1.22	-14.86	46.00	0.12	0.03	9.84
1.174	47.35	27.44	1.35	-18.56	46.00	0.12	0.03	9.84
1.178	46.57	29.46	0.57	-16.54	46.00	0.13	0.04	9.85
1.182	47.42	31.54	1.42	-14.46	46.00	0.12	0.03	9.84
1.186	47.21	28.06	1.21	-17.94	46.00	0.12	0.03	9.84
1.190	47.36	30.22	1.36	-15.78	46.00	0.13	0.04	9.85
1.194	46.15	26.57	0.15	-19.43	46.00	0.12	0.03	9.84
1.198	46.46	31.85	0.46	-14.15	46.00	0.13	0.04	9.85
1.202	47.77	30.20	1.77	-15.80	46.00	0.13	0.04	9.85
1.206	47.32	30.48	1.32	-15.52	46.00	0.12	0.03	9.84
1.270	44.66	23.95	-1.34	-22.05	46.00	0.13	0.04	9.85
1.342	42.46	27.80	-3.54	-18.20	46.00	0.14	0.04	9.85
2.006	39.37	19.70	-6.63	-26.30	46.00	0.17	0.05	9.86
2.166	37.80	19.02	-8.20	-26.98	46.00	0.18	0.05	9.87
2.338	37.29	17.33	-8.71	-28.67	46.00	0.18	0.05	9.87

Title: FCC Class B - Conducted Emissions - White Lead  
 File: Agilent - Conducted - Pre-Test - Neutral - VPx Sensor - Tx Mode - FCC Class B.set  
 Operator: Kyle Fujimoto  
 EUT Type: VPx Sensor 900 MHz with LCD  
 EUT Condition: The EUT was continuously frequency hopping  
 Comments: Company: Mesa Labs, Inc.  
 Model: CM-000272  
 S/N: 52000001

7/27/2016 9:29:46 AM  
 Sequence: Preliminary Scan

FCC Class B - Conducted Emissions - White Lead

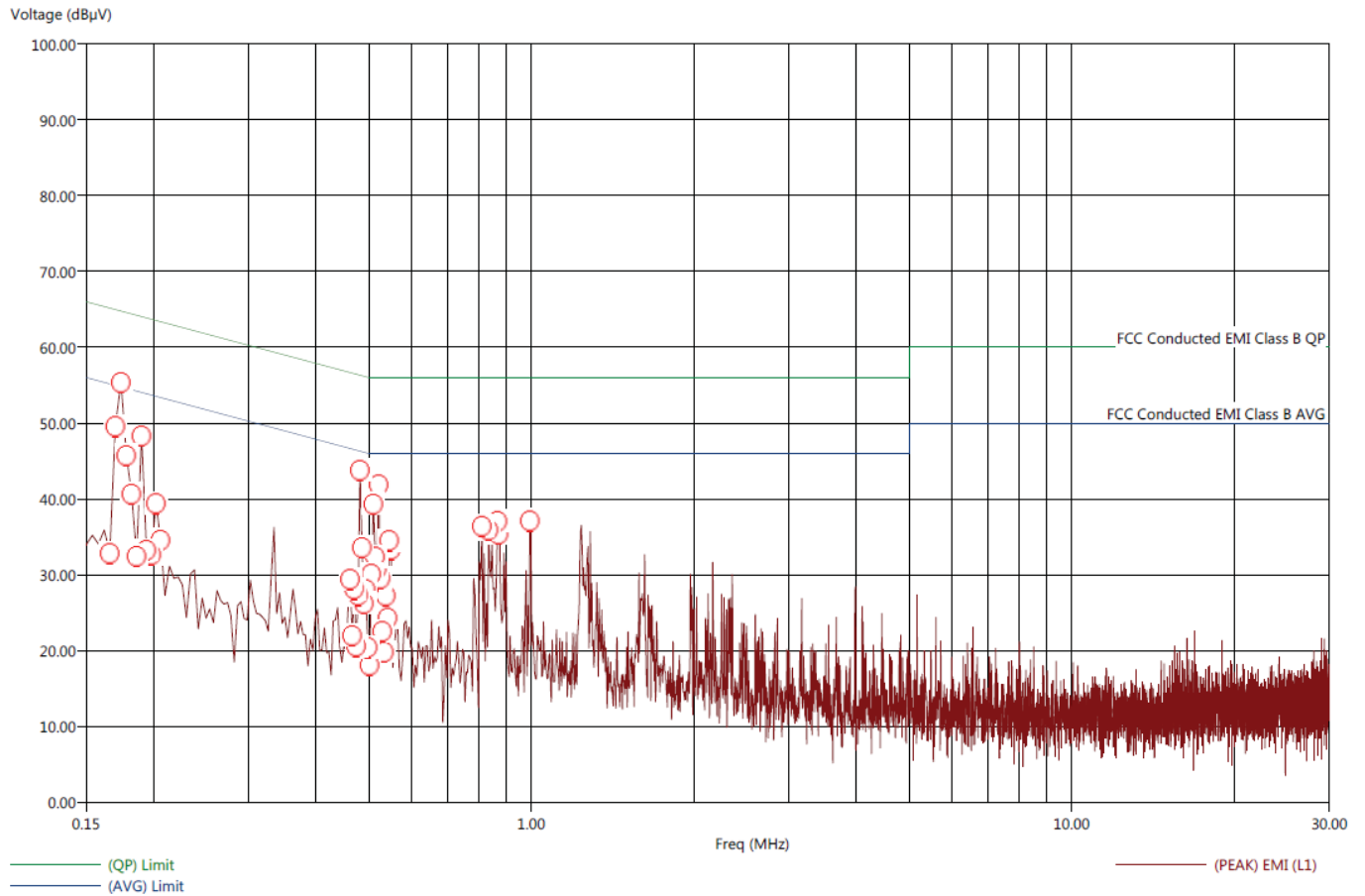

Title: FCC Class B - Conducted Emissions - White Lead  
 File: Agilent - Conducted - Final Test - Neutral - VPx Sensor - Tx Mode - FCC Class B.set  
 Operator: Kyle Fujimoto  
 EUT Type: VPx Sensor 900 MHz with LCD  
 EUT Condition: The EUT was continuously frequency hopping  
 Comments: Company: Mesa Labs, Inc.  
 Model: CM-000272  
 S/N: 52000001

7/27/2016 9:32:08 AM  
 Sequence: Final Measurements

FCC Class B - Conducted Emissions - White Lead

Freq (MHz)	(PEAK) EMI (dBμV)	(AVG) EMI (dBμV)	(PEAK) Margin AVL (dB)	(AVG) Margin AVL (dB)	(AVG) Limit (dBμV)	Cable (dB)	Transducer (dB)	Filter (dB)
0.166	59.33	41.10	4.42	-13.81	54.91	0.07	0.43	9.83
0.170	59.39	41.05	4.42	-13.92	54.97	0.07	0.43	9.83
0.174	58.08	39.57	3.33	-15.18	54.76	0.07	0.42	9.83
0.178	59.29	41.08	4.38	-13.83	54.91	0.07	0.43	9.83
0.182	52.79	34.12	-1.66	-20.33	54.44	0.07	0.39	9.83
0.186	52.69	33.69	-1.74	-20.74	54.43	0.07	0.39	9.83
0.190	49.16	30.16	-5.02	-24.02	54.19	0.08	0.38	9.83
0.194	46.62	28.24	-7.25	-25.63	53.88	0.08	0.36	9.83
0.198	54.00	29.64	-0.14	-24.50	54.14	0.08	0.37	9.83
0.202	45.94	27.52	-7.81	-26.23	53.75	0.08	0.35	9.83
0.206	44.93	26.47	-8.66	-27.12	53.59	0.08	0.34	9.83
0.462	46.40	23.26	0.13	-23.01	46.27	0.08	0.02	9.84
0.466	46.31	22.46	-0.11	-23.96	46.43	0.08	0.02	9.84
0.470	45.32	22.00	-1.05	-24.37	46.38	0.08	0.02	9.84
0.474	45.85	23.43	-0.41	-22.83	46.26	0.08	0.02	9.84
0.478	45.29	25.06	-0.84	-21.07	46.13	0.08	0.02	9.84
0.482	45.75	22.98	-0.56	-23.33	46.31	0.08	0.02	9.84
0.486	45.75	25.40	-0.34	-20.69	46.09	0.08	0.02	9.84
0.490	46.90	26.95	0.90	-19.05	46.00	0.08	0.02	9.84
0.494	46.17	26.67	0.17	-19.33	46.00	0.08	0.02	9.84
0.498	46.58	22.62	0.30	-23.66	46.29	0.08	0.02	9.84
0.502	46.77	26.96	0.77	-19.04	46.00	0.08	0.02	9.84
0.506	44.50	25.07	-1.50	-20.93	46.00	0.08	0.02	9.84
0.510	46.55	23.33	0.42	-22.80	46.13	0.08	0.02	9.84
0.514	46.19	26.28	0.19	-19.72	46.00	0.08	0.02	9.84
0.518	39.81	20.80	-6.19	-25.20	46.00	0.08	0.02	9.84
0.522	47.23	25.85	1.23	-20.15	46.00	0.08	0.02	9.84
0.526	47.21	26.39	1.21	-19.61	46.00	0.08	0.02	9.84
0.530	46.98	27.09	0.98	-18.91	46.00	0.08	0.02	9.84
0.534	45.59	26.60	-0.41	-19.40	46.00	0.08	0.02	9.84
0.538	39.31	20.27	-6.69	-25.73	46.00	0.08	0.02	9.84
0.542	43.79	24.18	-2.21	-21.82	46.00	0.08	0.02	9.84
0.546	44.32	25.23	-1.68	-20.77	46.00	0.08	0.02	9.84
0.550	41.04	22.70	-4.96	-23.30	46.00	0.08	0.02	9.84
0.810	47.73	25.04	1.73	-20.96	46.00	0.10	0.03	9.84
0.834	47.91	26.04	1.91	-19.96	46.00	0.10	0.03	9.84
0.866	44.89	24.66	-1.11	-21.34	46.00	0.10	0.03	9.84
0.870	45.73	25.33	-0.27	-20.67	46.00	0.10	0.03	9.84
0.874	44.99	24.52	-1.01	-21.48	46.00	0.10	0.03	9.84
0.994	41.09	20.56	-4.91	-25.44	46.00	0.11	0.03	9.84
0.998	42.75	18.41	-3.25	-27.59	46.00	0.11	0.03	9.84

Title: FCC Class B - Conducted Emissions - Black Lead  
 File: Agilent - Conducted - Pre-Test - Line - VPx Sensor - Rx Mode - FCC Class B.set  
 Operator: Kyle Fujimoto  
 EUT Type: VPx Sensor 900 MHz with LCD  
 EUT Condition: The EUT was continuously receiving  
 Comments: Company: Mesa Labs, Inc.  
 Model: CM-000272  
 S/N: 52000001

7/27/2016 9:54:18 AM  
 Sequence: Preliminary Scan

FCC Class B - Conducted Emissions - Black Lead

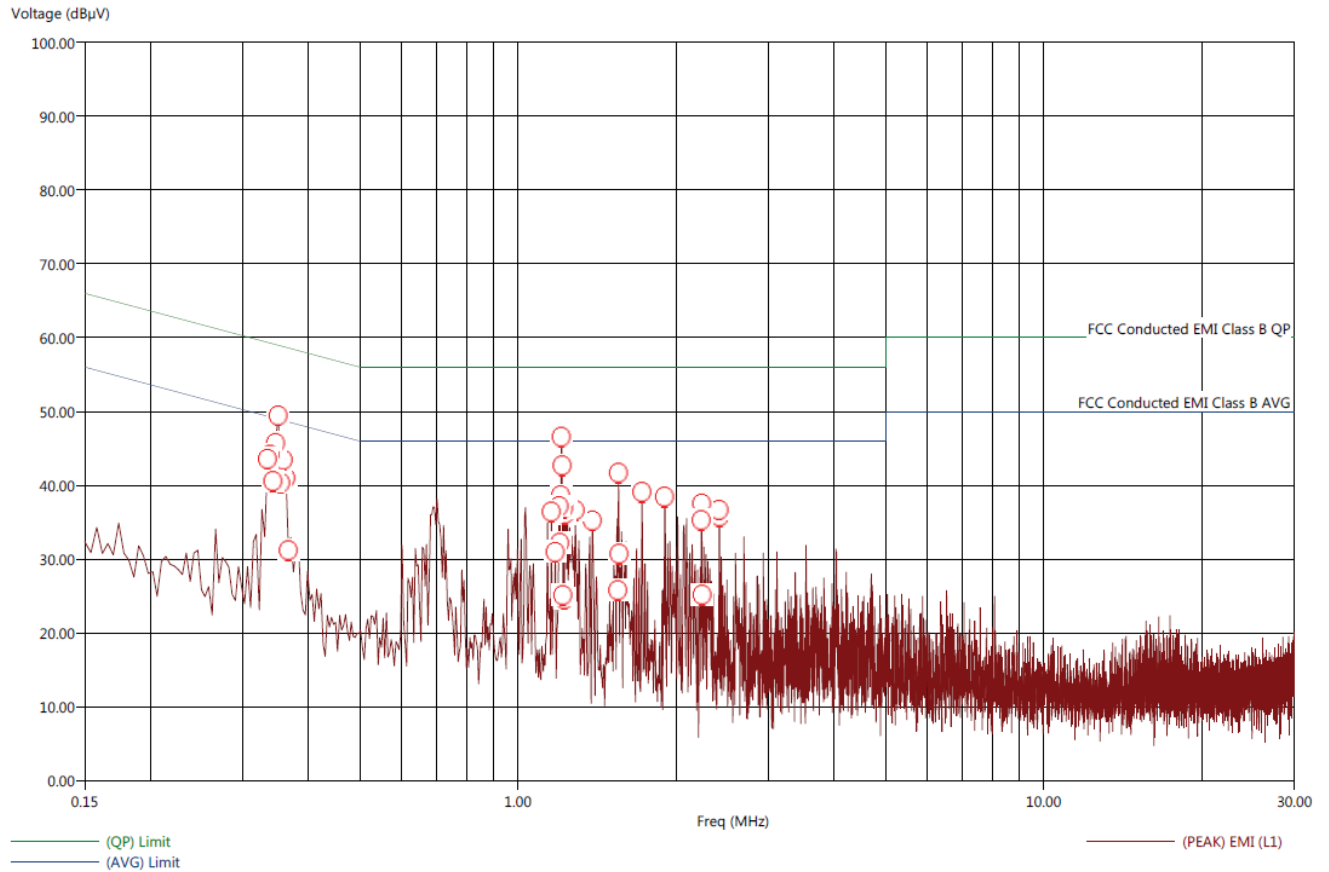

Title: FCC Class B - Conducted Emissions - Black Lead  
 File: Agilent - Conducted - Final Test - Line - VPx Sensor - Rx Mode - FCC Class B.set  
 Operator: Kyle Fujimoto  
 EUT Type: VPx Sensor 900 MHz with LCD  
 EUT Condition: The EUT was continuously receiving  
 Comments: Company: Mesa Labs, Inc.  
 Model: CM-000272  
 S/N: 52000001

7/27/2016 9:56:27 AM  
 Sequence: Final Measurements

FCC Class B - Conducted Emissions - Black Lead

Freq (MHz)	(PEAK) EMI (dBμV)	(AVG) EMI (dBμV)	(PEAK) Margin AVL (dB)	(AVG) Margin AVL (dB)	(AVG) Limit (dBμV)	Cable (dB)	Transducer (dB)	Filter (dB)
0.334	51.86	32.36	2.69	-16.81	49.17	0.08	0.05	9.84
0.338	51.65	32.47	2.53	-16.65	49.12	0.08	0.05	9.84
0.342	50.10	30.71	0.92	-18.47	49.18	0.08	0.05	9.84
0.346	52.13	30.96	3.08	-18.09	49.05	0.08	0.05	9.84
0.350	52.13	33.12	3.08	-15.93	49.05	0.08	0.05	9.84
0.354	52.08	33.06	3.01	-16.01	49.07	0.08	0.05	9.84
0.358	50.86	31.80	1.89	-17.17	48.97	0.08	0.04	9.84
0.362	45.99	25.79	-2.81	-23.01	48.80	0.08	0.04	9.84
0.366	49.38	29.94	0.46	-18.98	48.92	0.08	0.04	9.84
1.158	37.59	17.46	-8.41	-28.54	46.00	0.12	0.03	9.84
1.178	43.96	17.02	-2.04	-28.98	46.00	0.12	0.03	9.84
1.198	46.83	28.70	0.83	-17.30	46.00	0.13	0.04	9.85
1.202	46.88	29.51	0.88	-16.49	46.00	0.13	0.04	9.85
1.206	46.86	24.57	0.86	-21.43	46.00	0.13	0.04	9.85
1.210	45.88	28.64	-0.12	-17.36	46.00	0.13	0.04	9.85
1.214	47.04	29.89	1.04	-16.11	46.00	0.13	0.04	9.85
1.218	47.15	29.30	1.15	-16.70	46.00	0.13	0.04	9.85
1.222	44.37	29.15	-1.63	-16.85	46.00	0.13	0.04	9.85
1.226	46.92	27.35	0.92	-18.65	46.00	0.13	0.04	9.85
1.230	47.00	29.84	1.00	-16.16	46.00	0.13	0.04	9.85
1.234	46.86	29.24	0.86	-16.76	46.00	0.13	0.04	9.85
1.286	38.84	22.18	-7.16	-23.82	46.00	0.13	0.04	9.85
1.386	41.72	23.61	-4.28	-22.39	46.00	0.14	0.04	9.85
1.550	40.61	18.68	-5.39	-27.32	46.00	0.15	0.04	9.85
1.554	41.92	22.24	-4.08	-23.76	46.00	0.15	0.04	9.85
1.558	39.87	19.14	-6.13	-26.86	46.00	0.15	0.04	9.85
1.722	37.16	17.04	-8.84	-28.96	46.00	0.16	0.05	9.86
1.902	39.26	11.96	-6.74	-34.04	46.00	0.16	0.05	9.86
2.234	39.37	18.16	-6.63	-27.84	46.00	0.18	0.05	9.87
2.238	40.01	20.25	-5.99	-25.75	46.00	0.18	0.05	9.87
2.242	38.89	17.16	-7.11	-28.84	46.00	0.18	0.05	9.87
2.414	37.53	16.62	-8.47	-29.38	46.00	0.18	0.05	9.87
2.418	37.51	16.49	-8.49	-29.51	46.00	0.18	0.05	9.87



Title: FCC Class B - Conducted Emissions - White Lead  
 File: Agilent - Conducted - Pre-Test - Neutral - VPx Sensor - Rx Mode - FCC Class B.set  
 Operator: Kyle Fujimoto  
 EUT Type: VPx Sensor 900 MHz with LCD  
 EUT Condition: The EUT was continuously receiving  
 Comments: Company: Mesa Labs, Inc.  
 Model: CM-000272  
 S/N: 52000001

7/27/2016 9:47:49 AM  
 Sequence: Preliminary Scan

FCC Class B - Conducted Emissions - White Lead

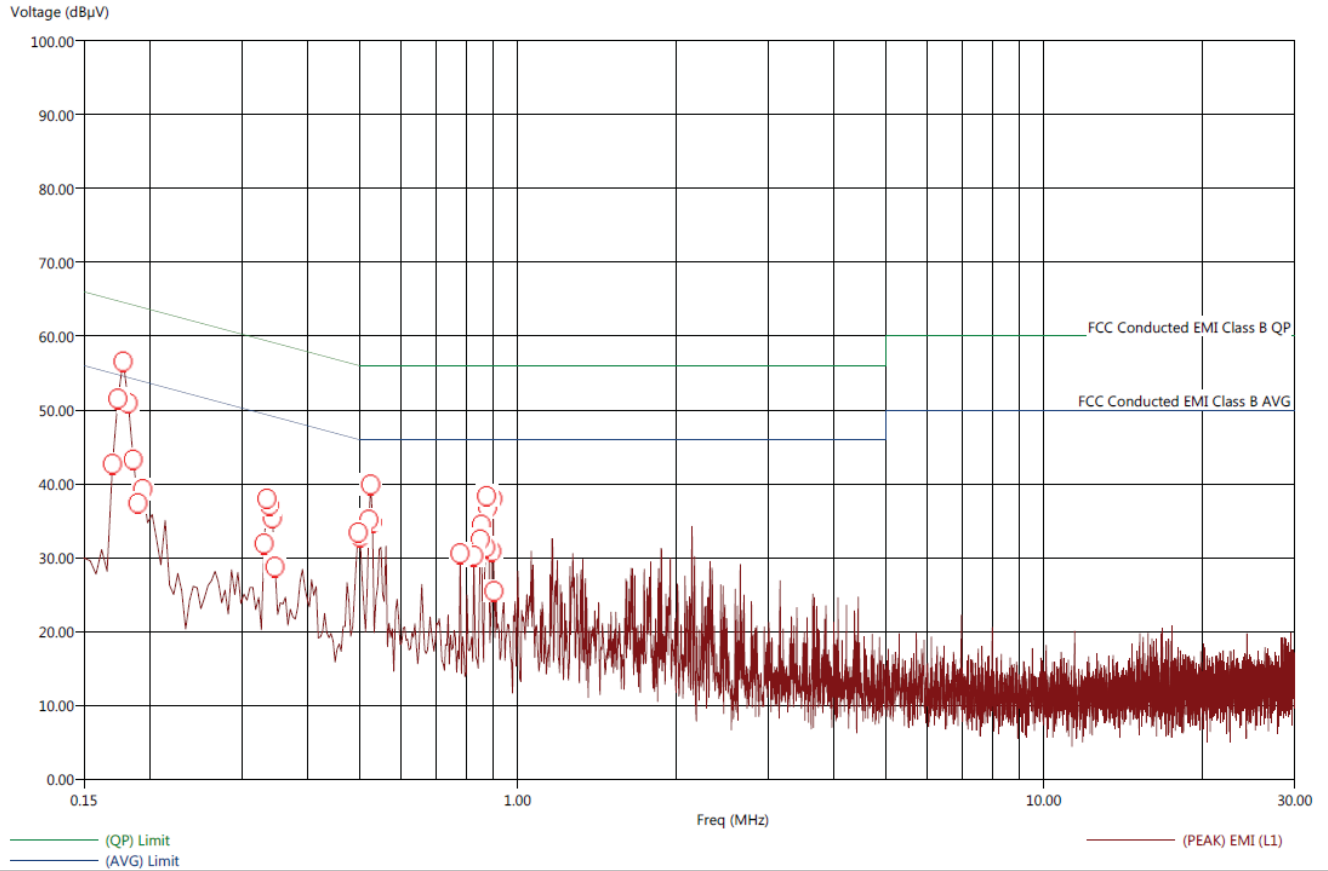

Title: FCC Class B - Conducted Emissions - White Lead  
 File: Agilent - Conducted - Final Test - Neutral - VPx Sensor - Rx Mode - FCC Class B.set  
 Operator: Kyle Fujimoto  
 EUT Type: VPx Sensor 900 MHz with LCD  
 EUT Condition: The EUT was continuously receiving  
 Comments: Company: Mesa Labs, Inc.  
 Model:CM-000272  
 S/N: 52000001

7/27/2016 9:49:23 AM  
 Sequence: Final Measurements

FCC Class B - Conducted Emissions - White Lead

Freq (MHz)	(PEAK) EMI (dBμV)	(AVG) EMI (dBμV)	(PEAK) Margin AVL (dB)	(AVG) Margin AVL (dB)	(AVG) Limit (dBμV)	Cable (dB)	Transducer (dB)	Filter (dB)
0.170	58.93	40.41	3.74	-14.78	55.19	0.07	0.44	9.83
0.174	59.63	41.93	4.61	-13.09	55.02	0.07	0.43	9.83
0.178	57.02	40.39	2.33	-14.30	54.69	0.07	0.41	9.83
0.182	49.60	30.61	-4.60	-23.59	54.20	0.07	0.38	9.83
0.186	49.90	30.83	-4.31	-23.38	54.22	0.07	0.38	9.83
0.190	49.87	31.31	-4.34	-22.90	54.22	0.07	0.38	9.83
0.194	48.82	30.32	-5.28	-23.78	54.10	0.08	0.37	9.83
0.330	53.41	35.54	4.21	-13.66	49.21	0.08	0.05	9.84
0.334	53.85	35.61	4.74	-13.50	49.11	0.08	0.04	9.84
0.338	53.89	30.09	4.61	-19.19	49.28	0.08	0.05	9.84
0.342	53.75	36.08	4.64	-13.03	49.11	0.08	0.04	9.84
0.346	54.23	32.40	4.97	-16.86	49.25	0.08	0.05	9.84
0.498	43.54	24.36	-2.46	-21.64	46.00	0.08	0.02	9.84
0.502	37.49	19.94	-8.68	-26.23	46.17	0.08	0.02	9.84
0.522	47.55	28.38	1.55	-17.62	46.00	0.08	0.02	9.84
0.526	46.92	28.40	0.92	-17.60	46.00	0.08	0.02	9.84
0.530	41.65	23.66	-4.35	-22.34	46.00	0.08	0.02	9.84
0.778	37.32	19.04	-8.68	-26.96	46.00	0.10	0.03	9.84
0.826	36.94	18.89	-9.06	-27.11	46.00	0.10	0.03	9.84
0.850	49.06	30.06	3.06	-15.94	46.00	0.10	0.03	9.84
0.854	48.02	24.57	2.02	-21.43	46.00	0.10	0.03	9.84
0.870	44.42	25.55	-1.58	-20.45	46.00	0.10	0.03	9.84
0.874	44.56	25.91	-1.44	-20.09	46.00	0.10	0.03	9.84
0.878	49.14	29.82	3.14	-16.18	46.00	0.10	0.03	9.84
0.894	49.04	26.76	3.04	-19.24	46.00	0.10	0.03	9.84
0.898	38.16	18.81	-7.84	-27.19	46.00	0.11	0.03	9.84
0.902	47.87	28.92	1.87	-17.08	46.00	0.10	0.03	9.84

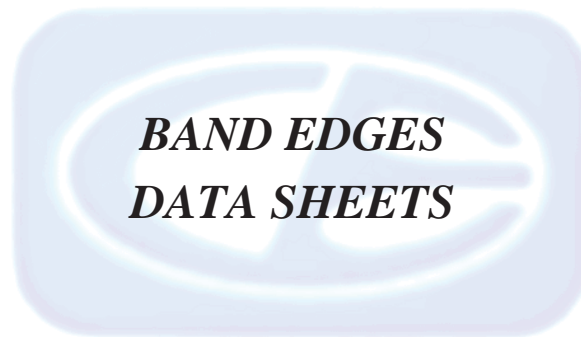

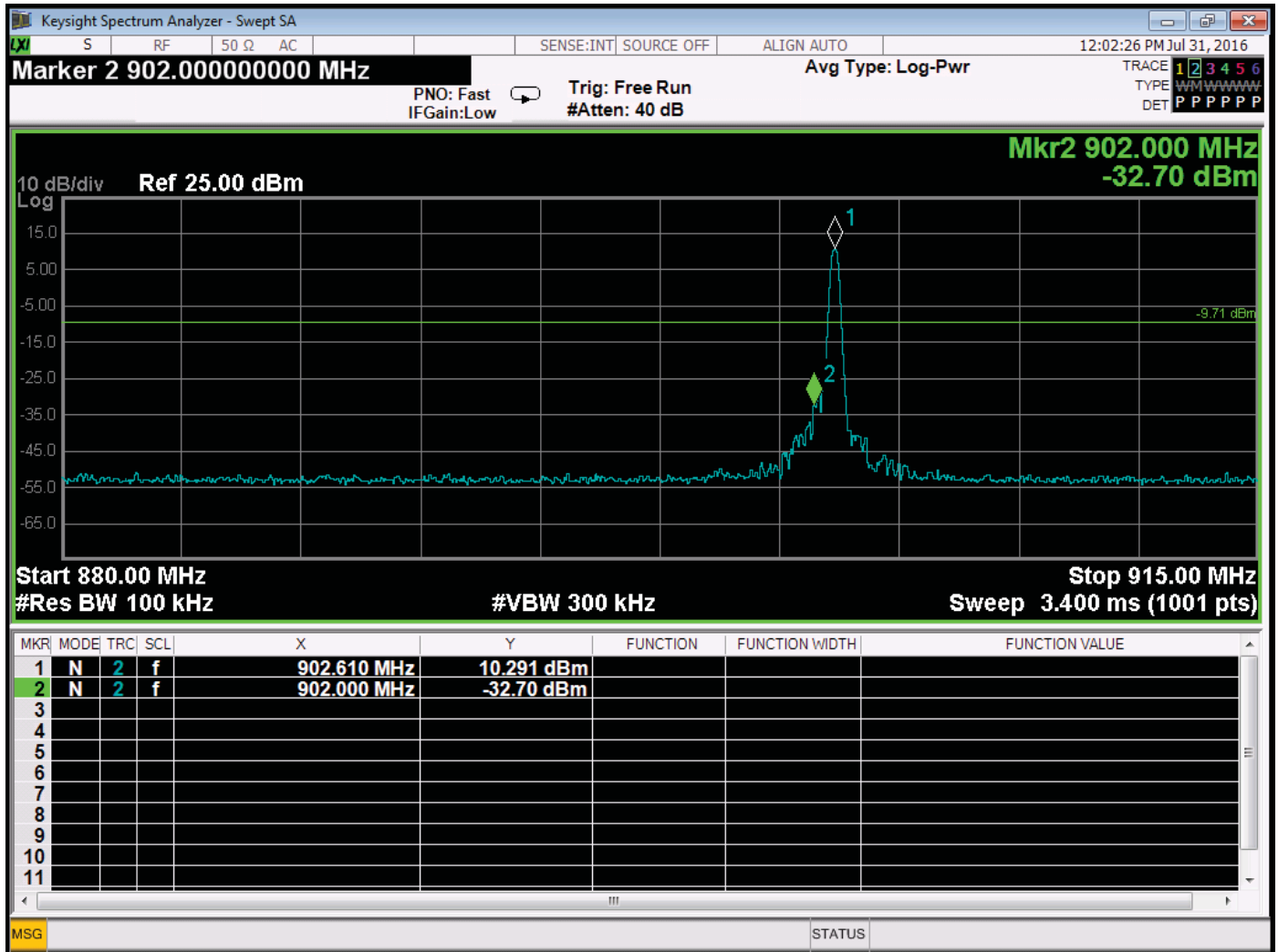

Band Edge – Low Channel – Fixed Frequency Mode



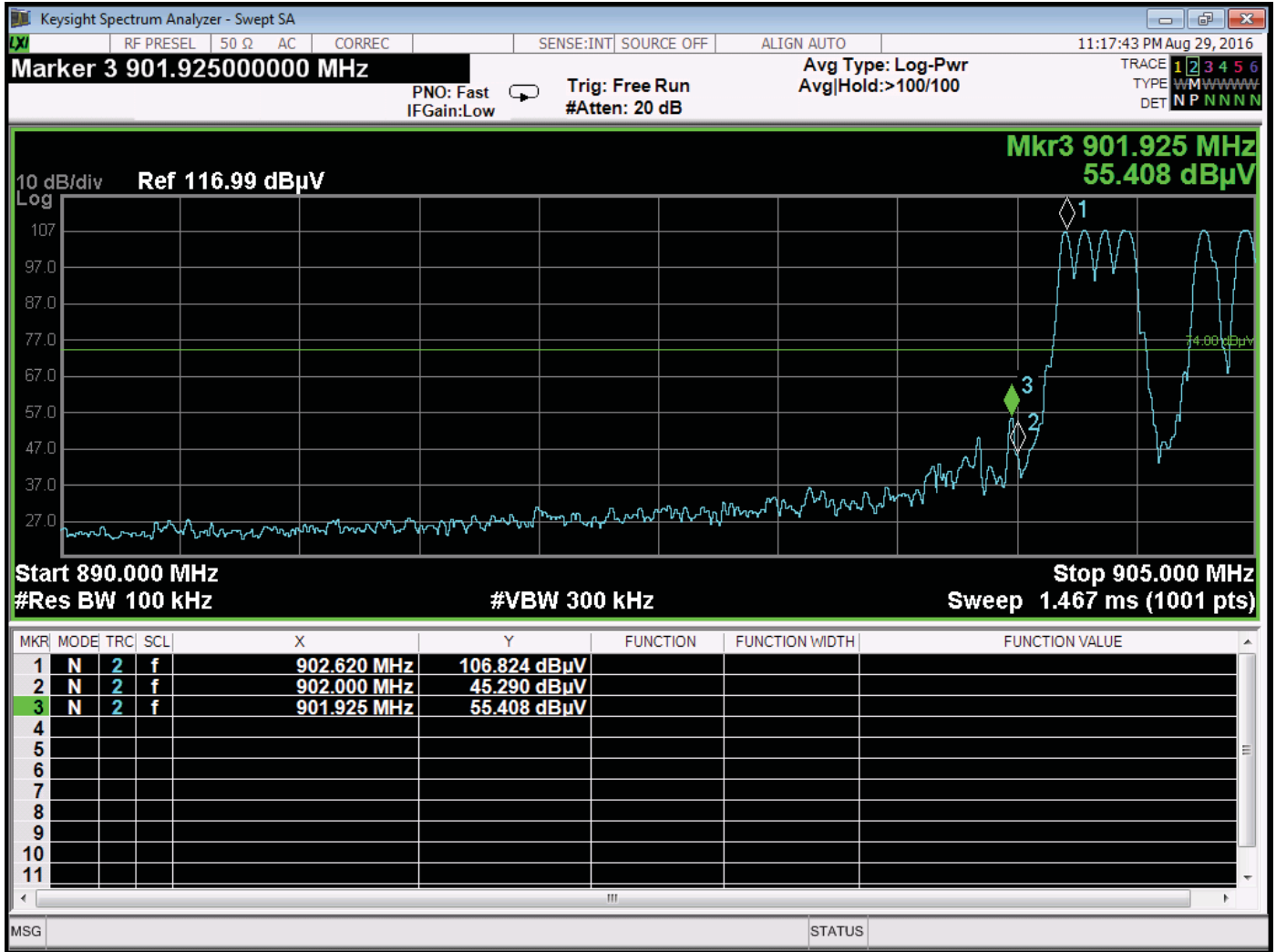

Band Edge – Low Channel – Frequency Hopping Mode

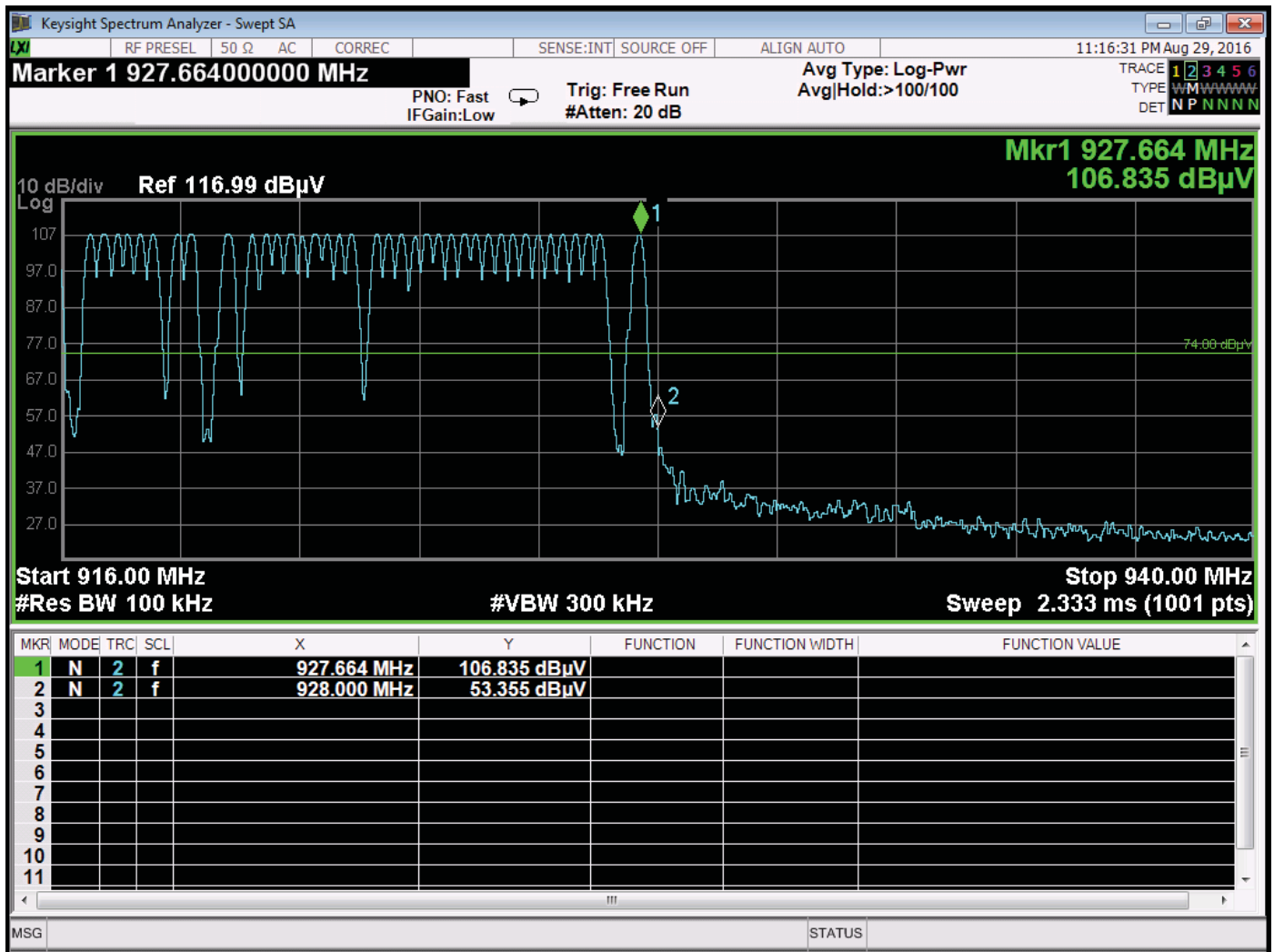

Band Edge – High Channel – Frequency Hopping Mode





***-20 DB BANDWIDTH  
DATA SHEETS***

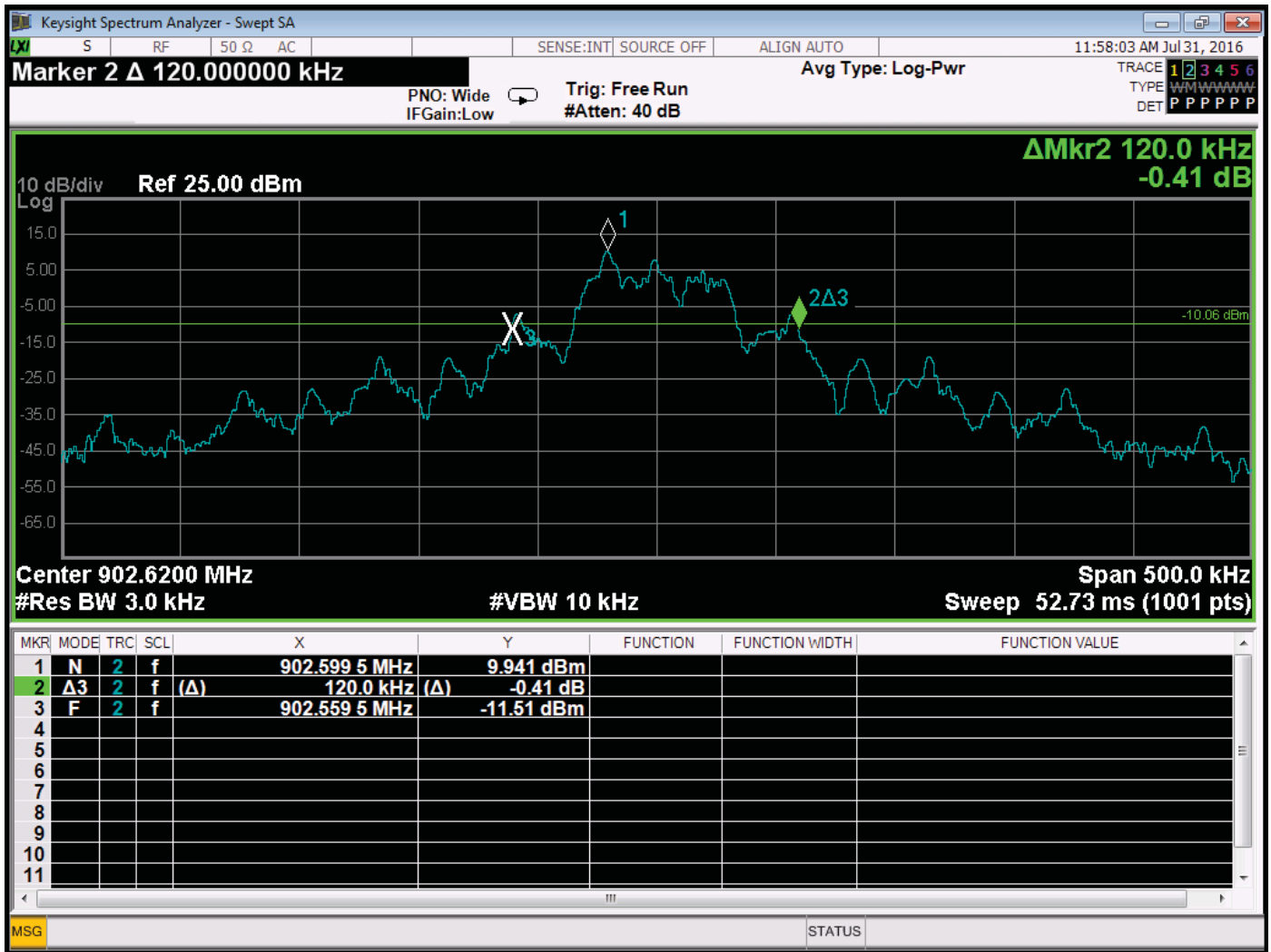

-20 dB Bandwidth – Low Channel

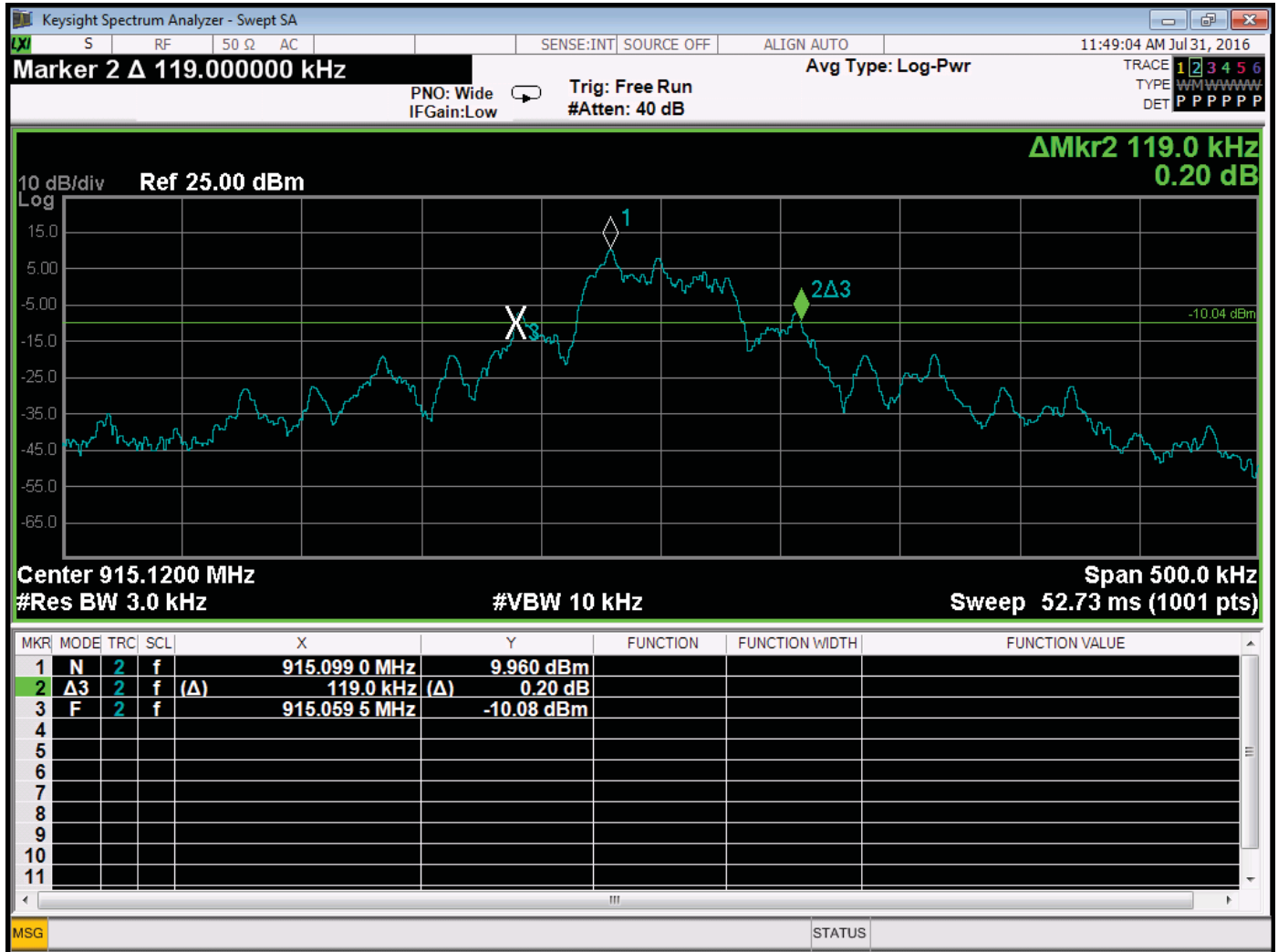

-20 dB Bandwidth – Middle Channel

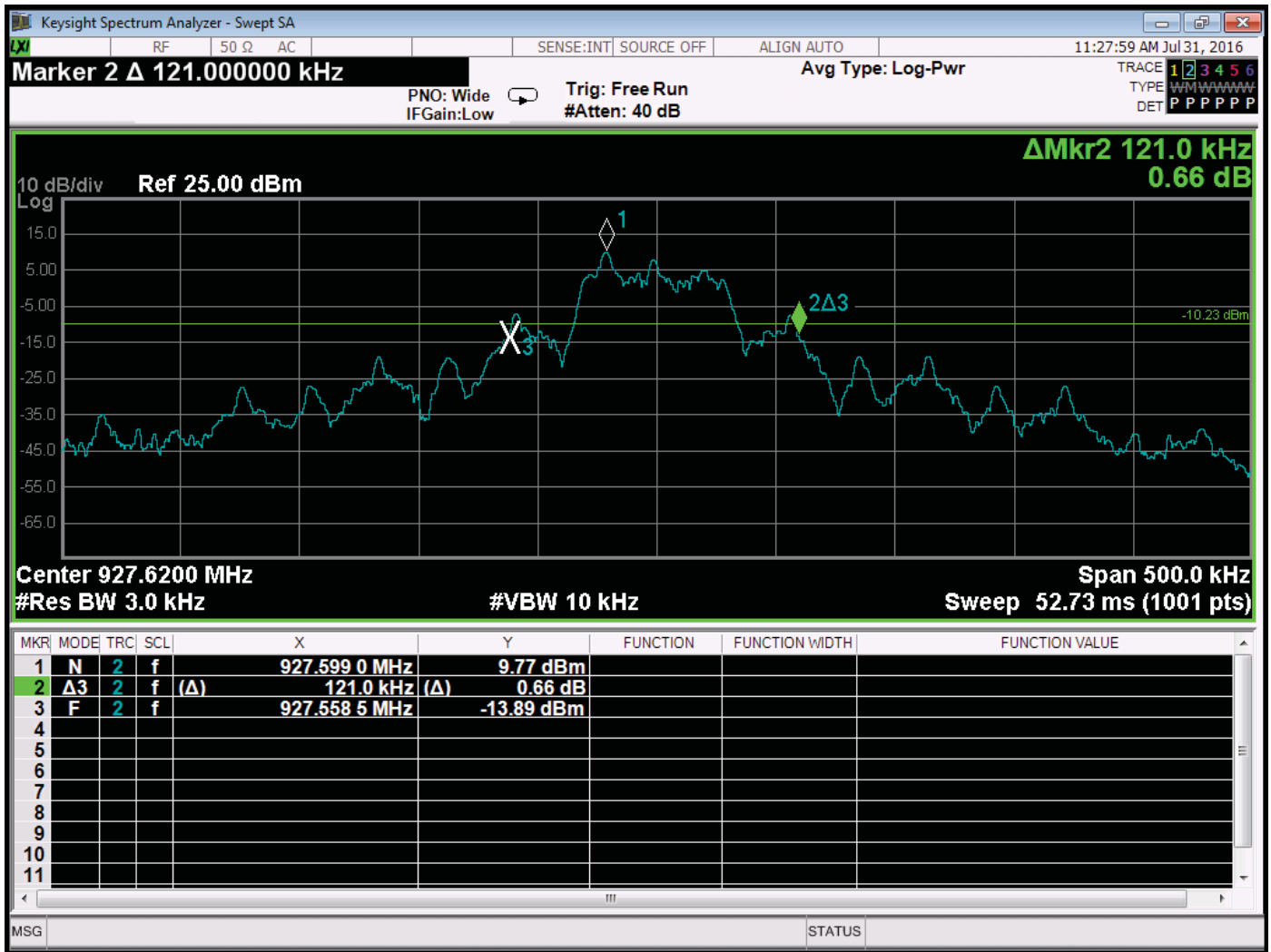

-20 dB Bandwidth – High Channel



***RF ANTENNA CONDUCTED  
DATA SHEETS***

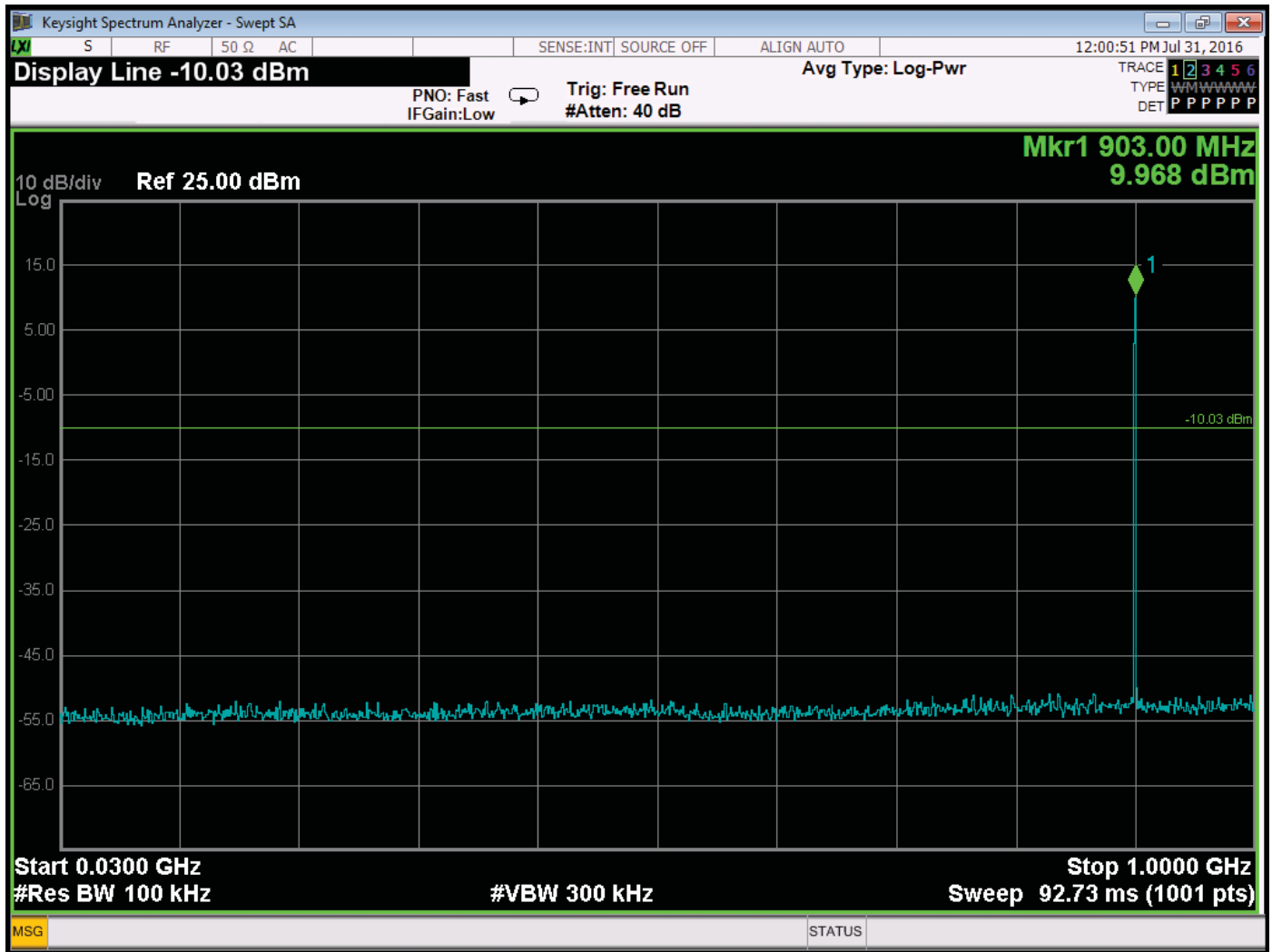

RF Antenna Conducted – Low Channel – 30 MHz to 1 GHz

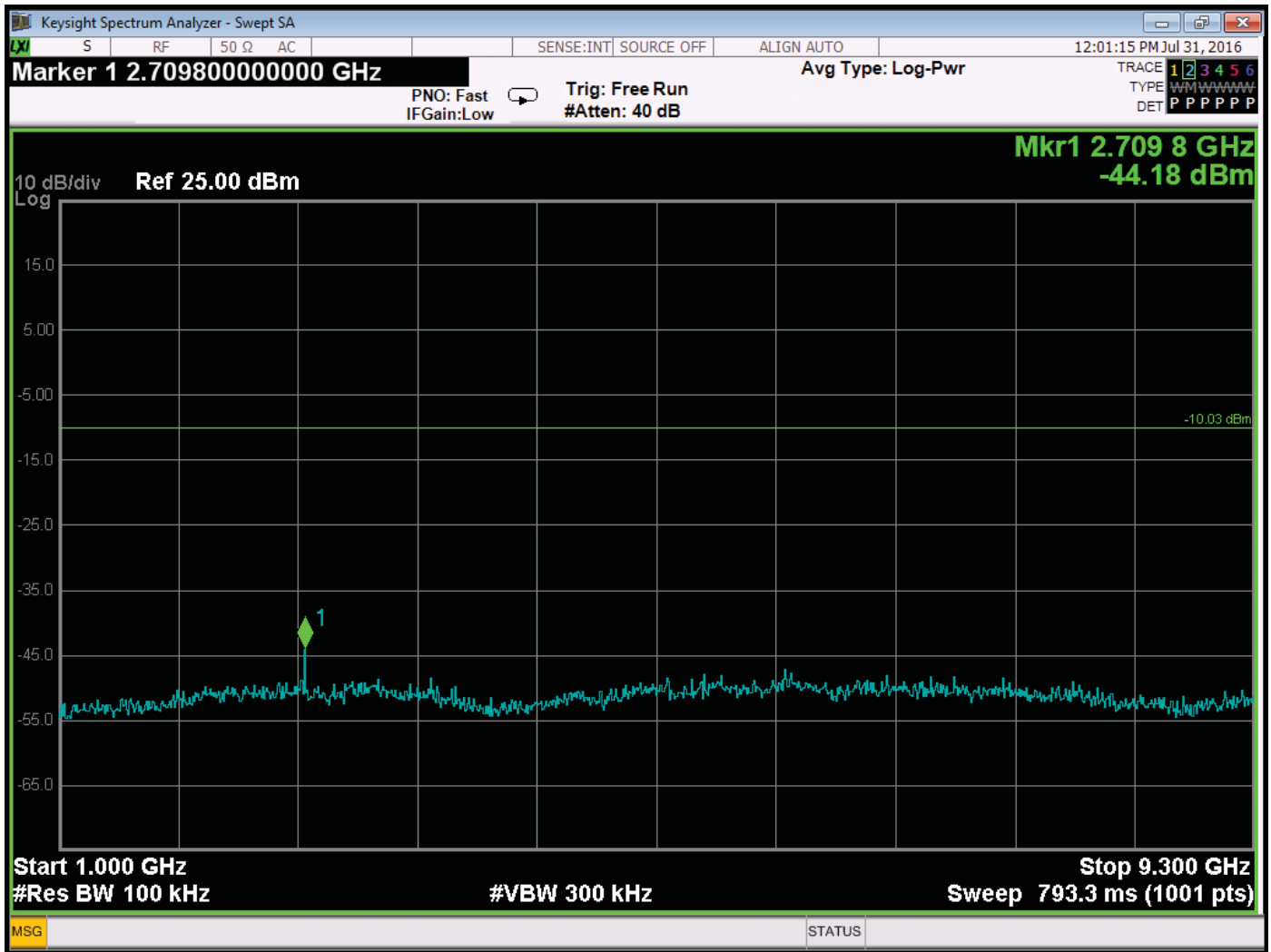

RF Antenna Conducted – Low Channel – 1 GHz to 9.3 GHz



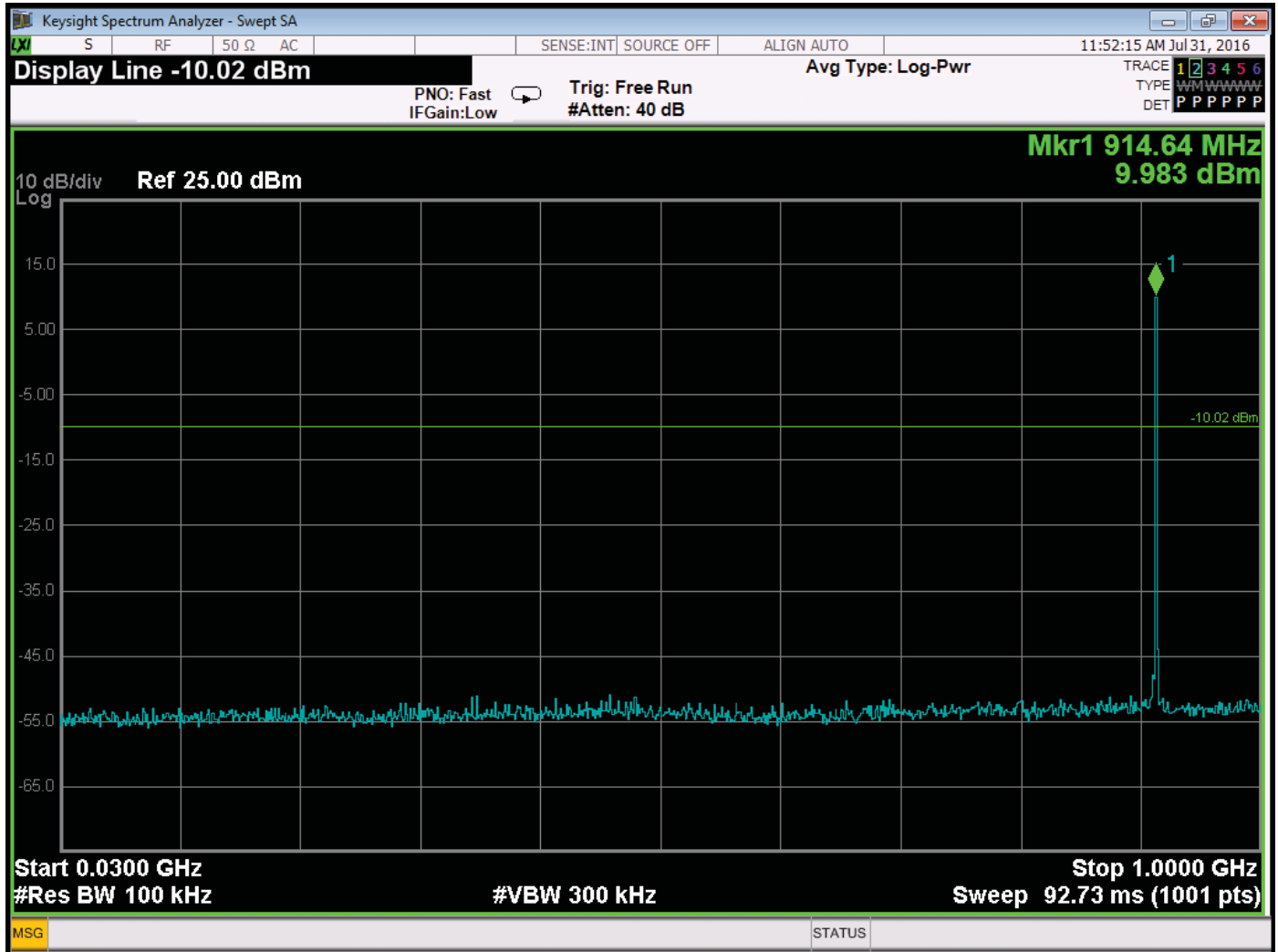

RF Antenna Conducted – Middle Channel – 30 MHz to 1 GHz

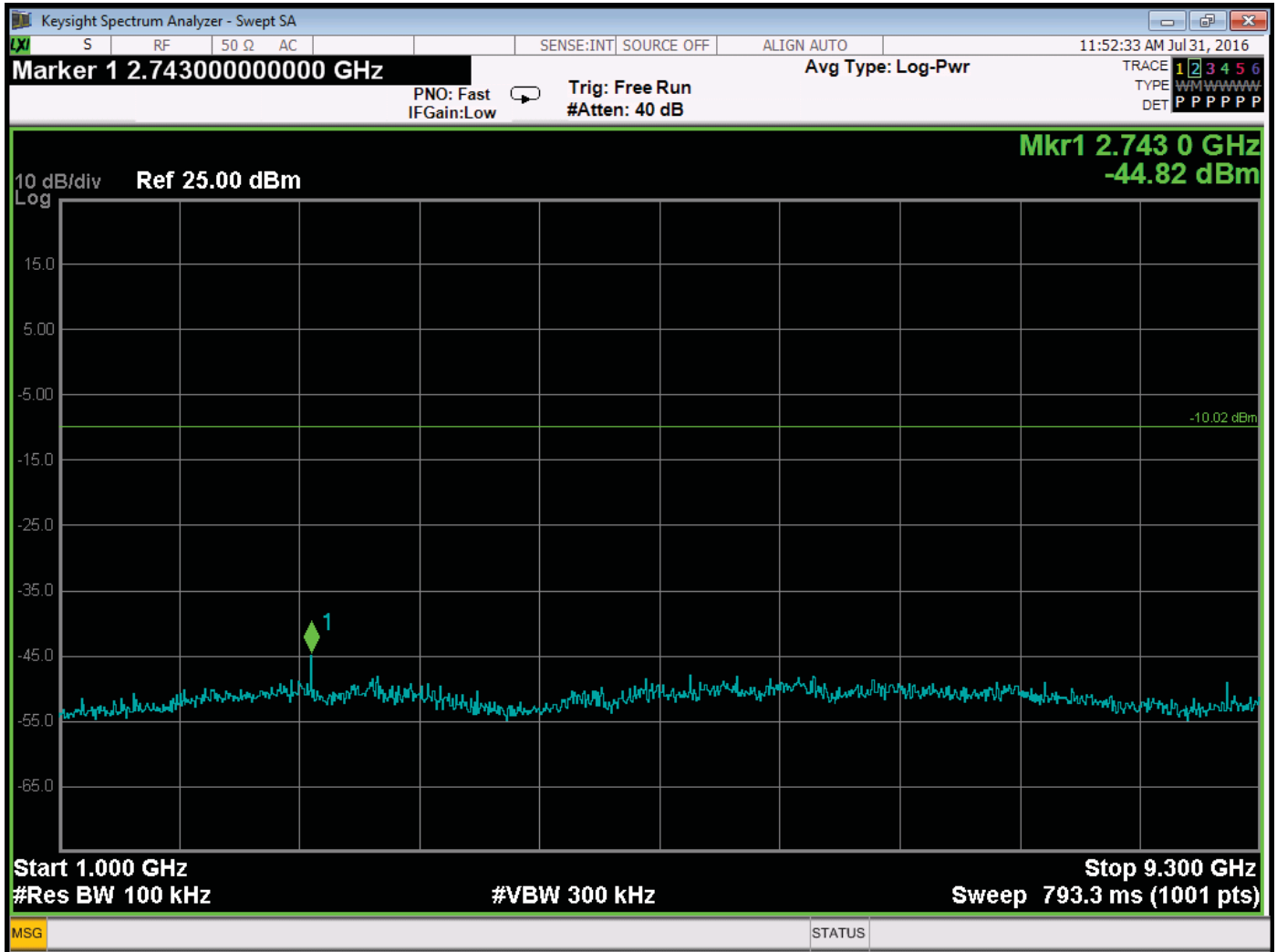

RF Antenna Conducted – Middle Channel – 1 GHz to 9.3 GHz

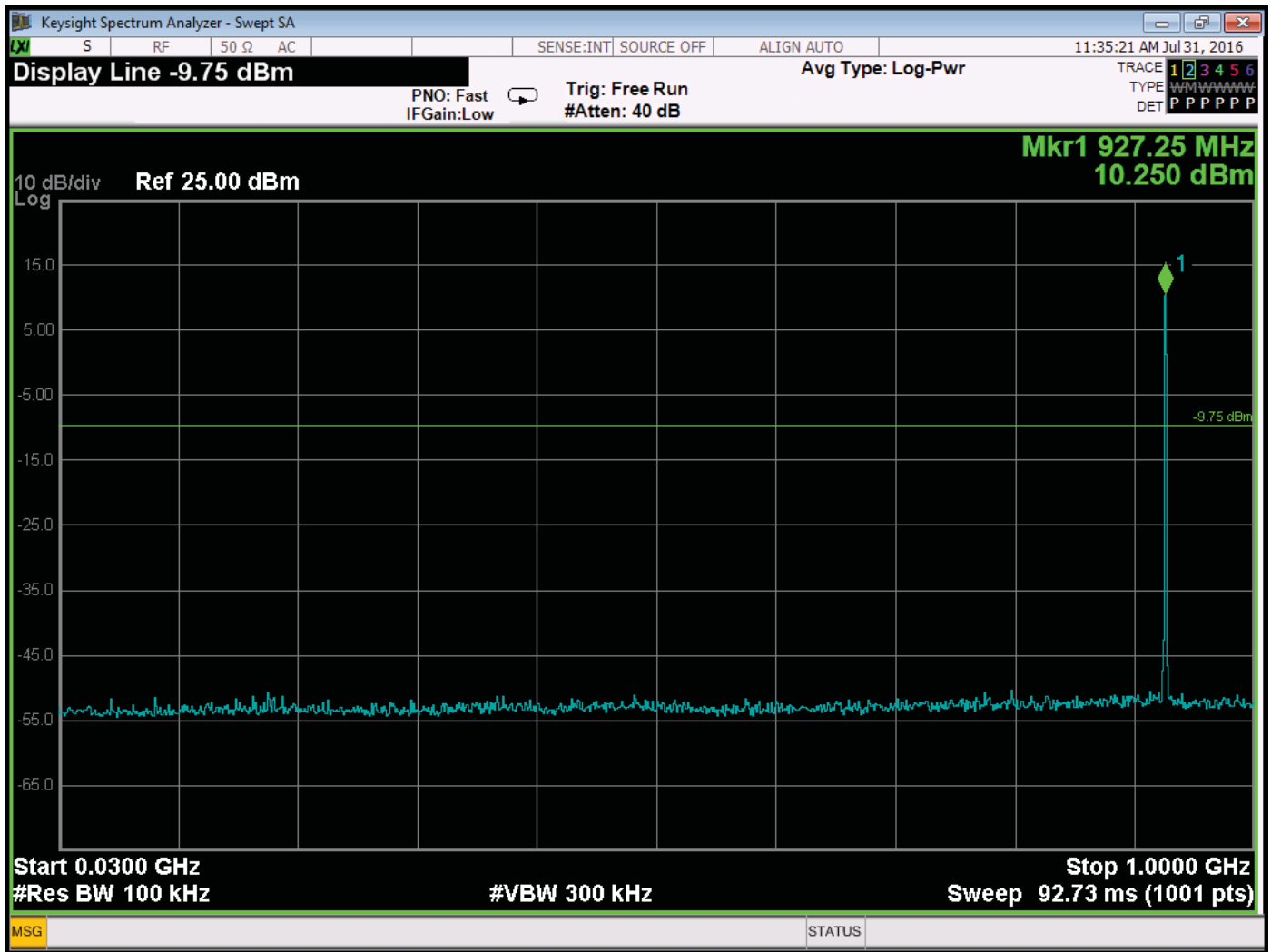

RF Antenna Conducted – High Channel – 30 MHz to 1 GHz

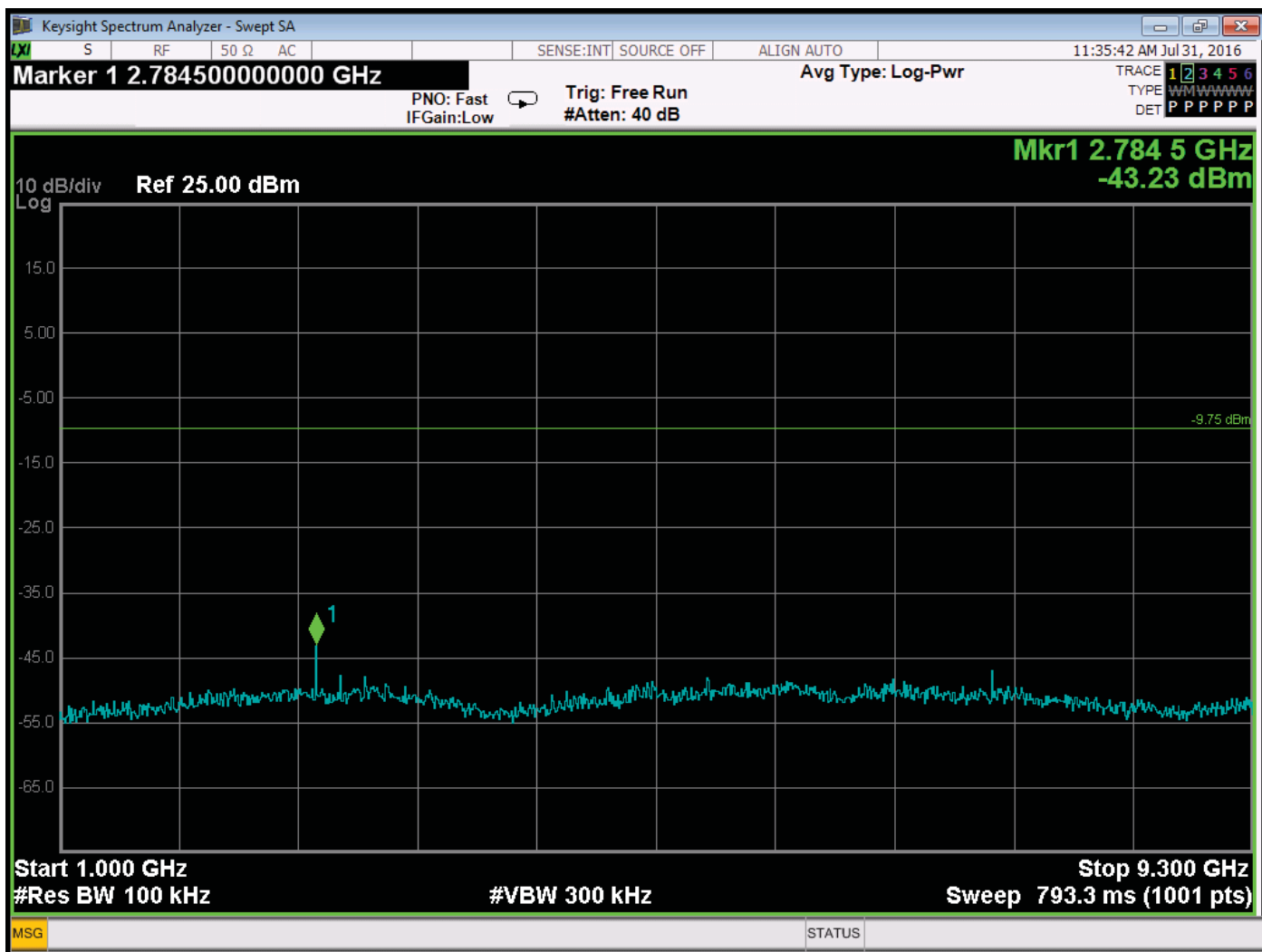

RF Antenna Conducted – High Channel – 1 GHz to 9.3 GHz



***PEAK POWER OUTPUT  
DATA SHEETS***

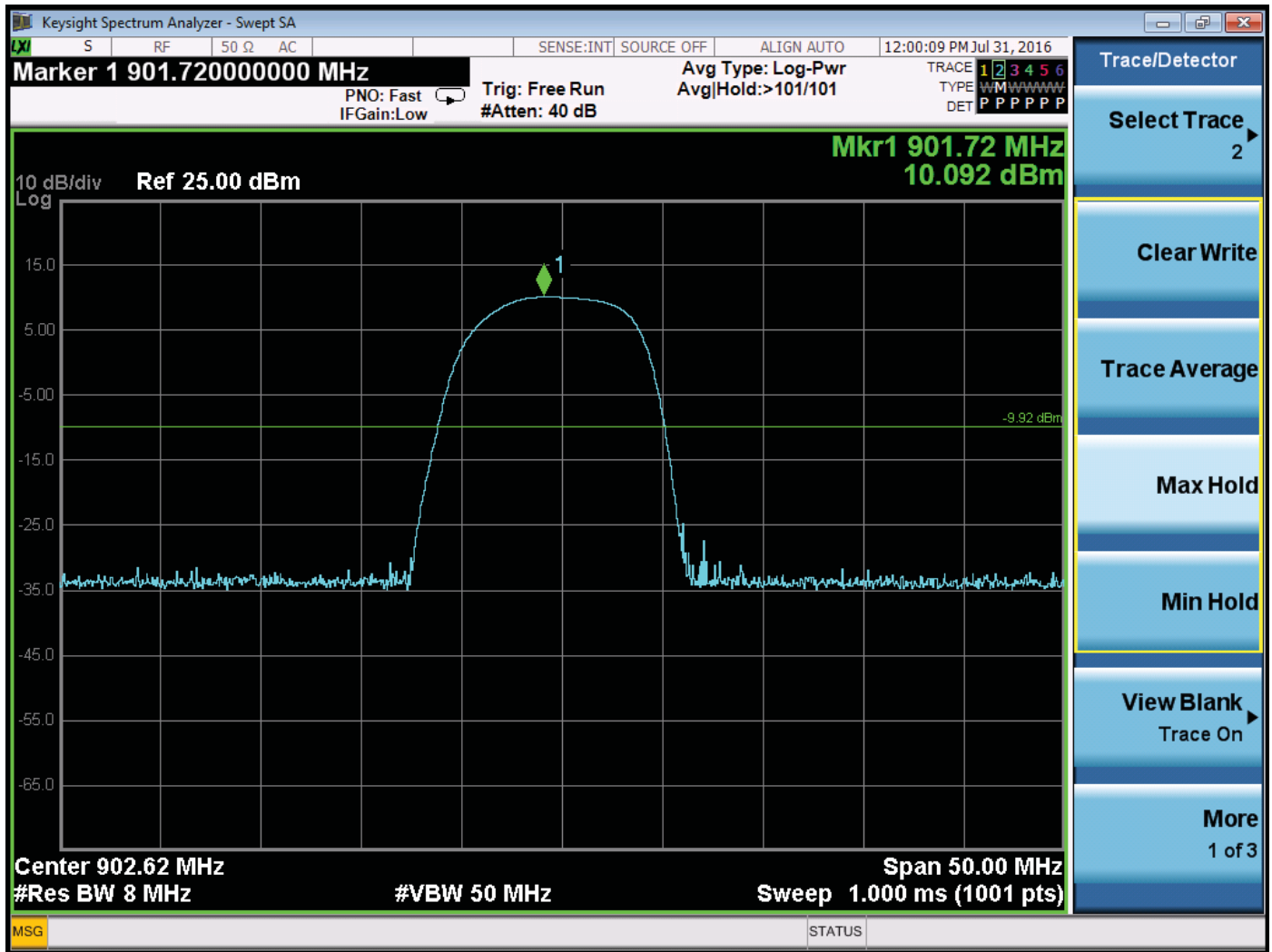

Peak Power Output – Low Channel

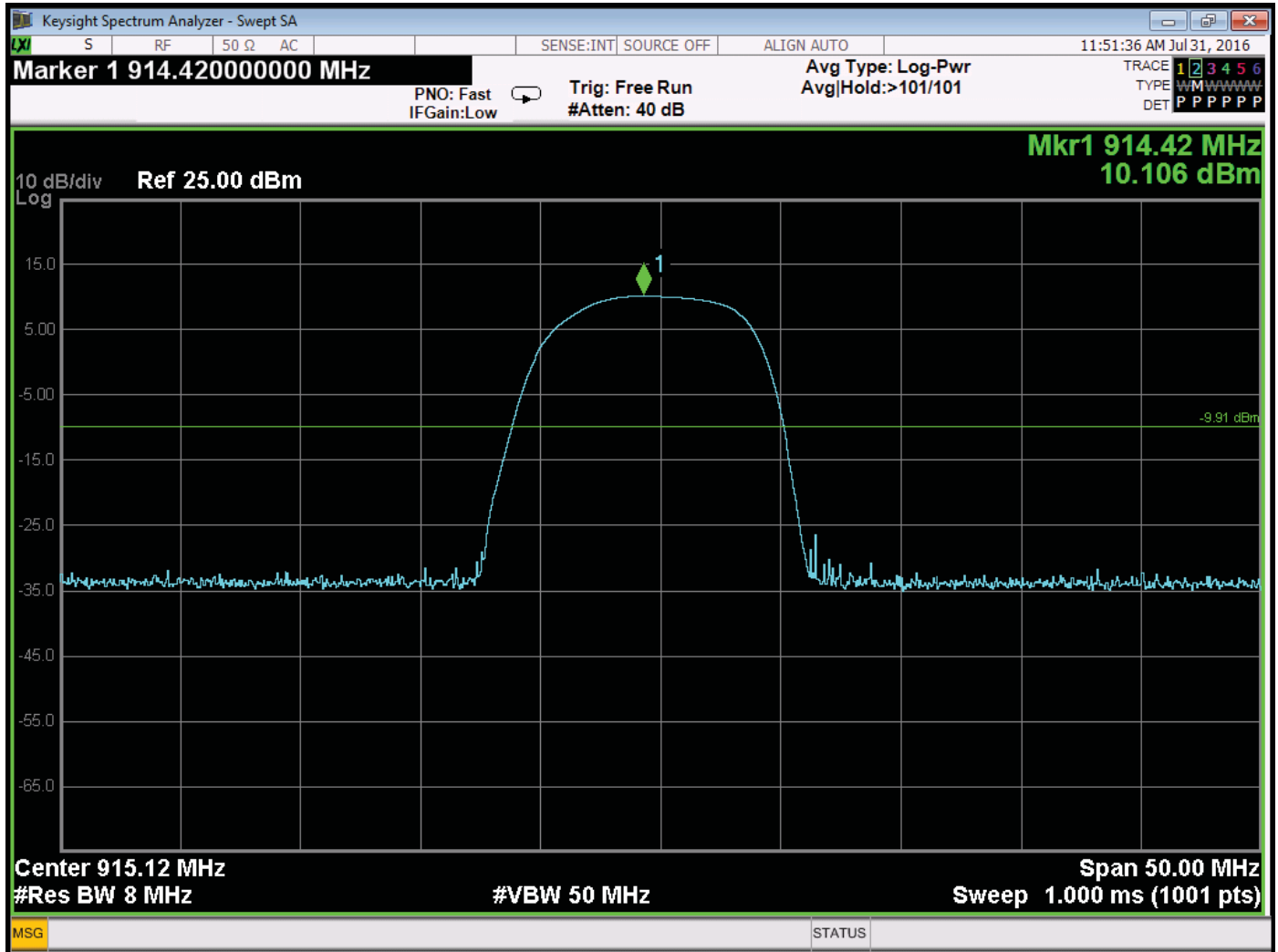

Peak Power Output – Middle Channel



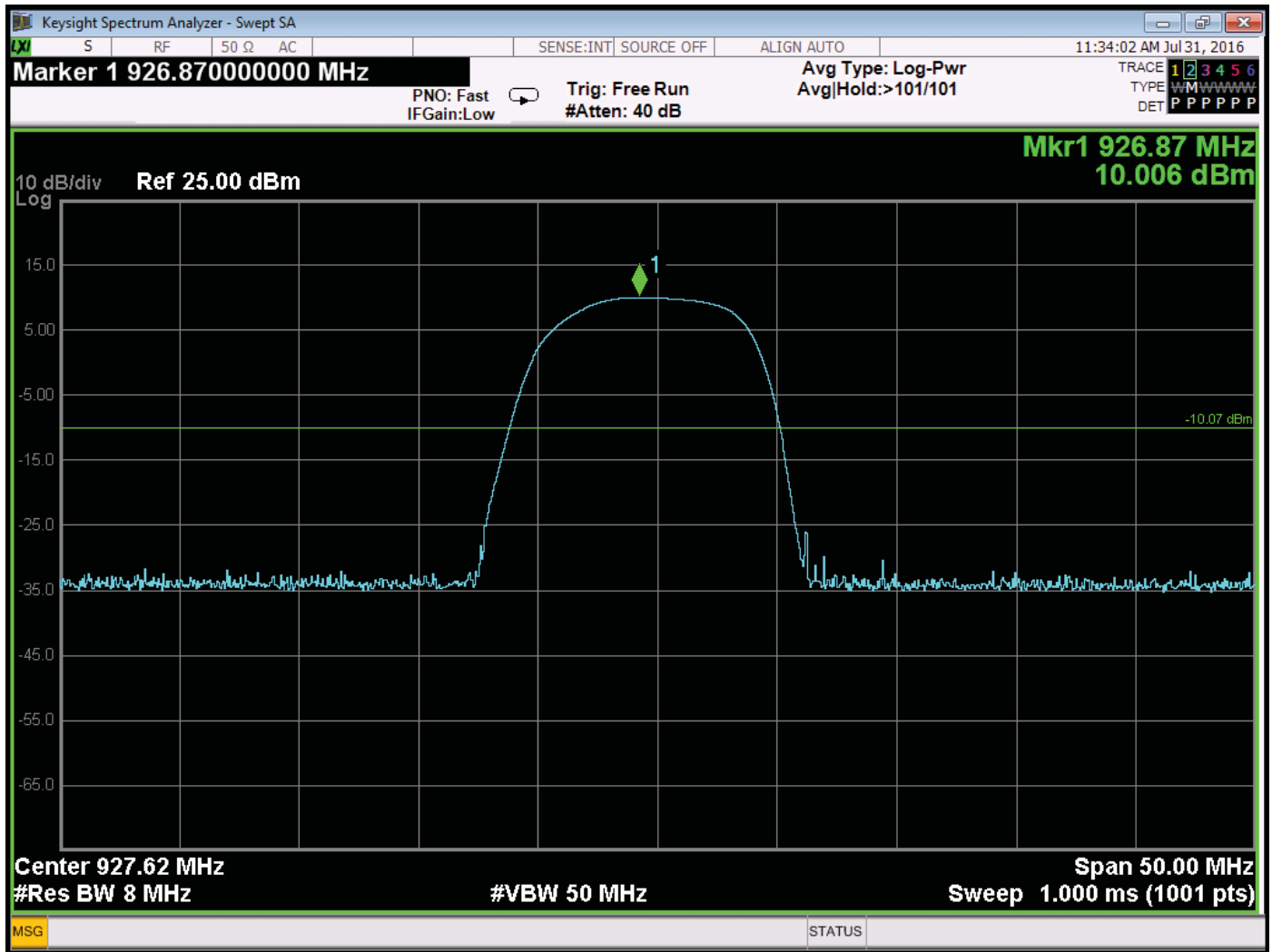

Peak Power Output – High Channel



***CHANNEL FREQUENCY SEPARATION  
DATA SHEET***

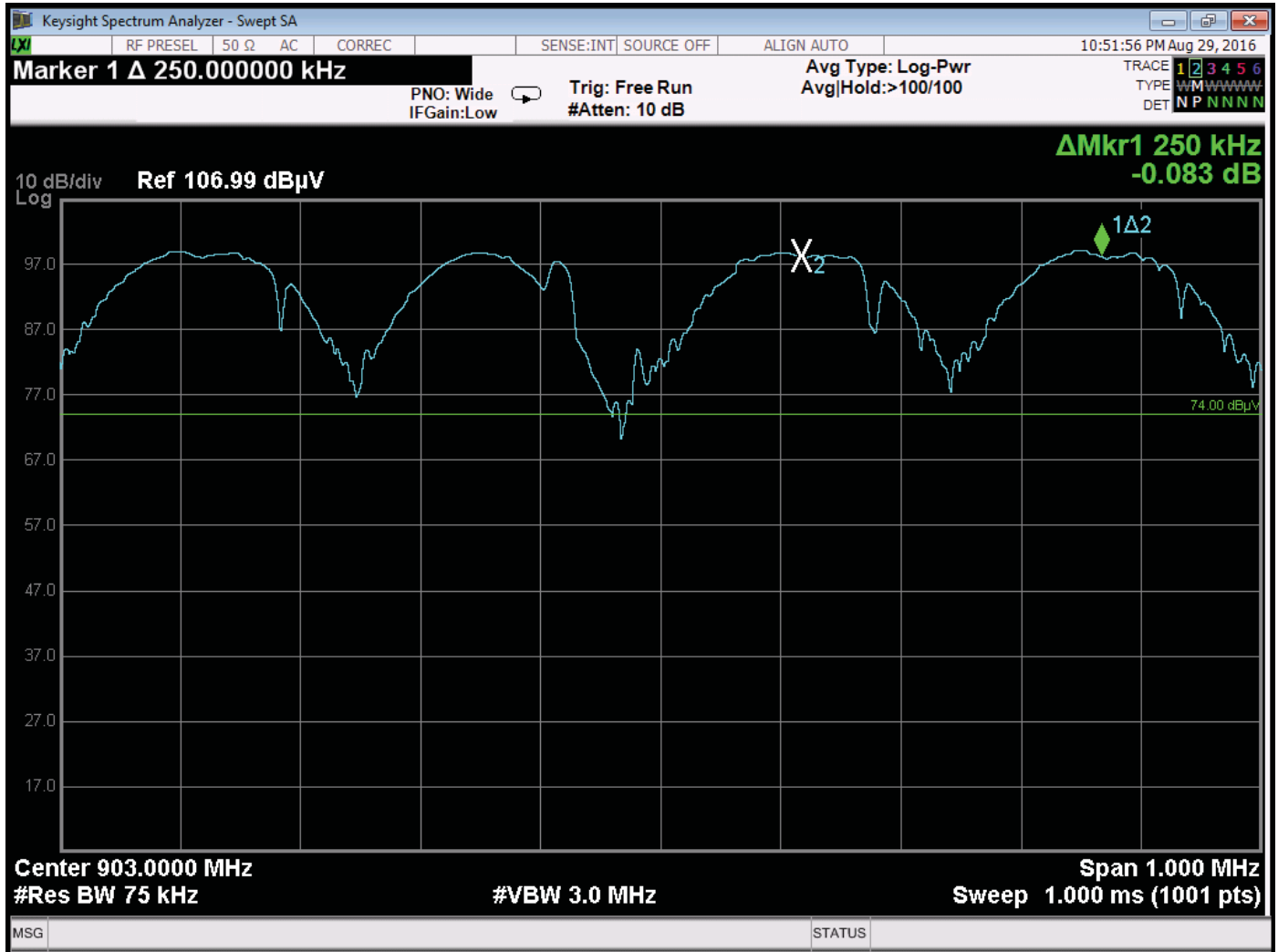

Channel Frequency Separation



***NUMBER OF FREQUENCIES***

***DATA SHEET***

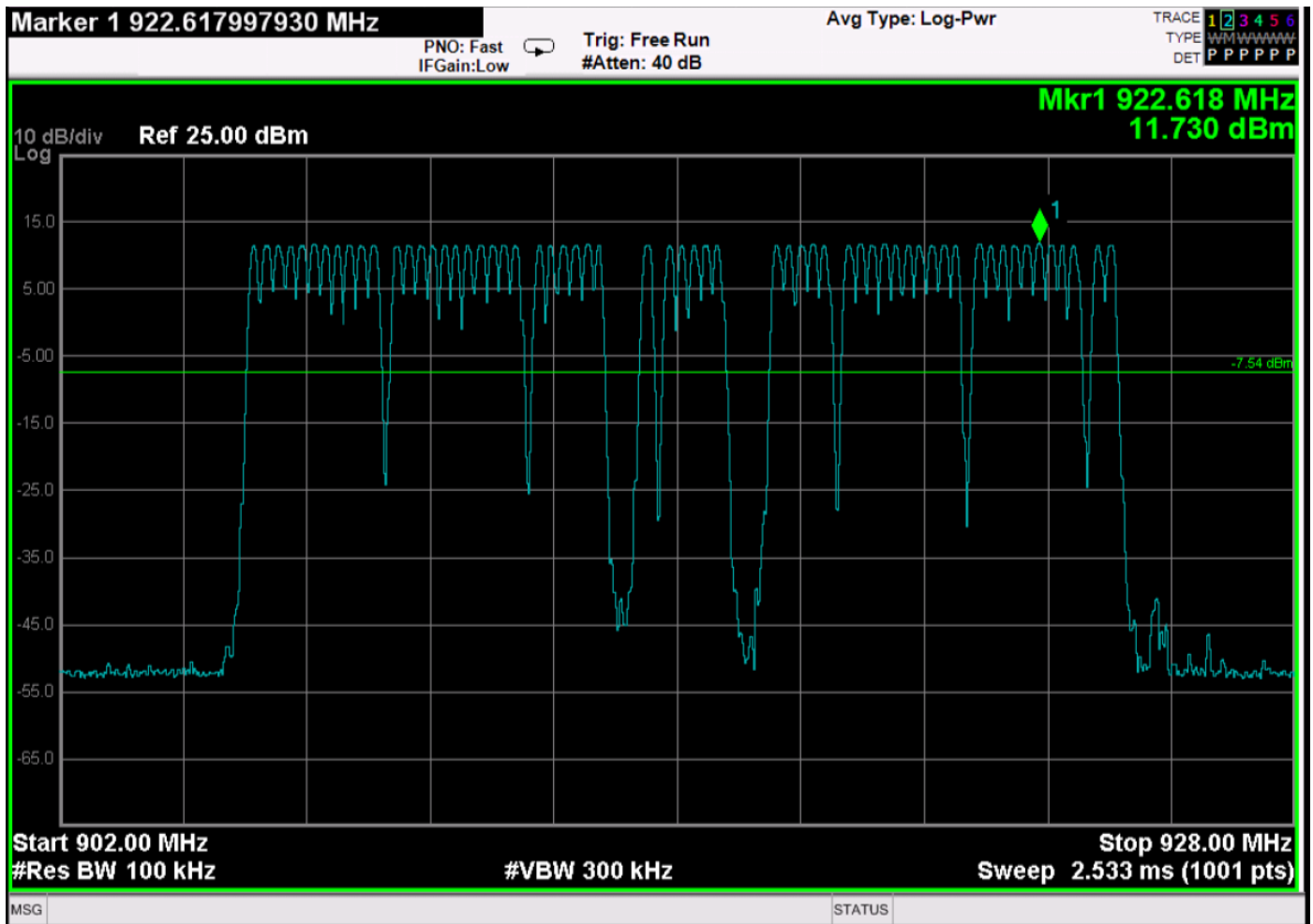

Number of Maximum Channels is 60 – Normal Band

**Brea Division**  
 114 Olinda Drive  
 Brea, CA 92823  
 (714) 579-0500

**Agoura Division**  
 2337 Troutdale Drive  
 Agoura, CA 91301  
 (818) 597-0600

**Silverado Division**  
 19121 El Toro Road  
 Silverado, CA 92676  
 (949) 589-0700

**Lake Forest Division**  
 20621 Pascal Way  
 Lake Forest, CA 92630  
 (949) 587-0400

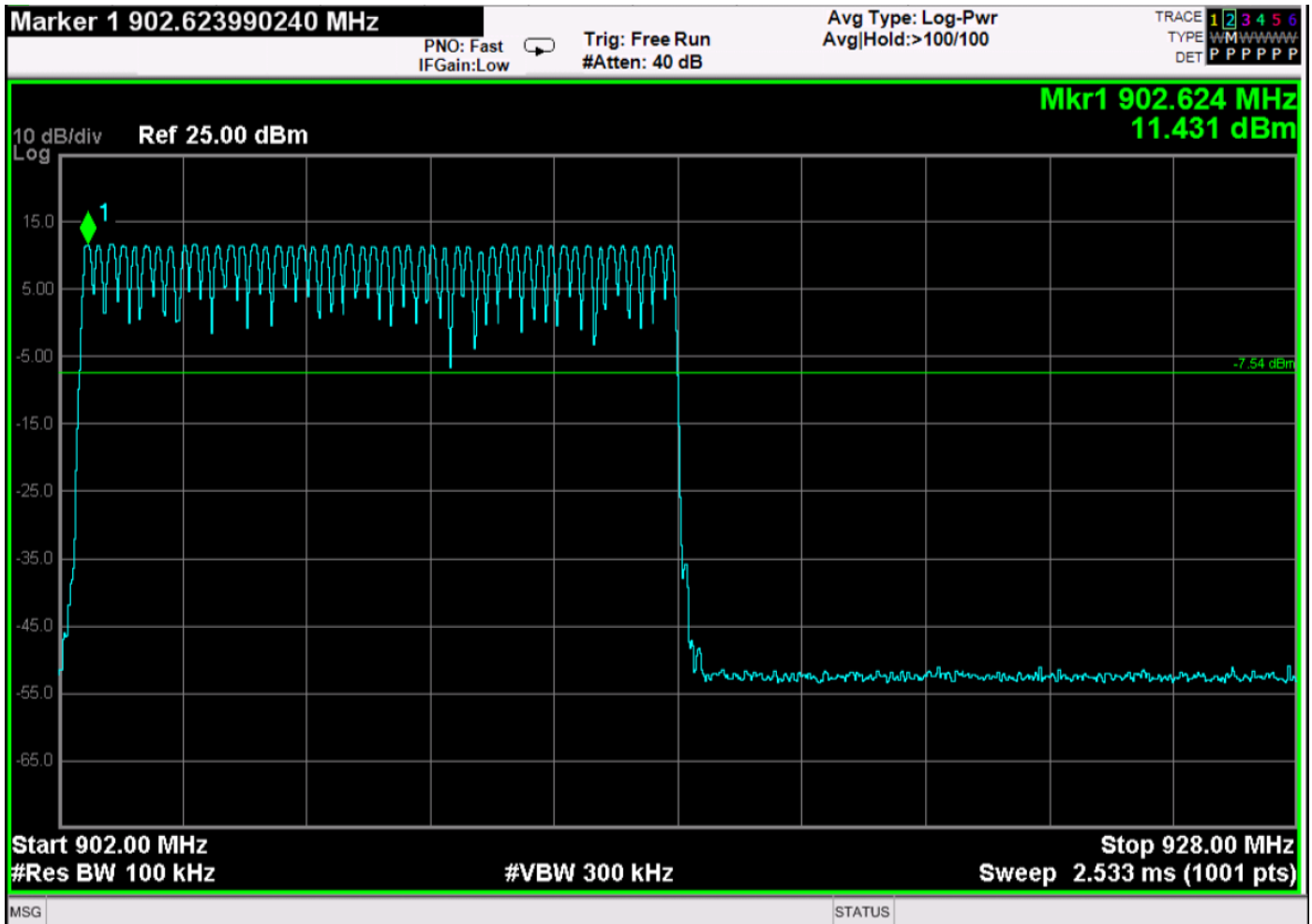

Number of Maximum Channels is 50 – Low Band

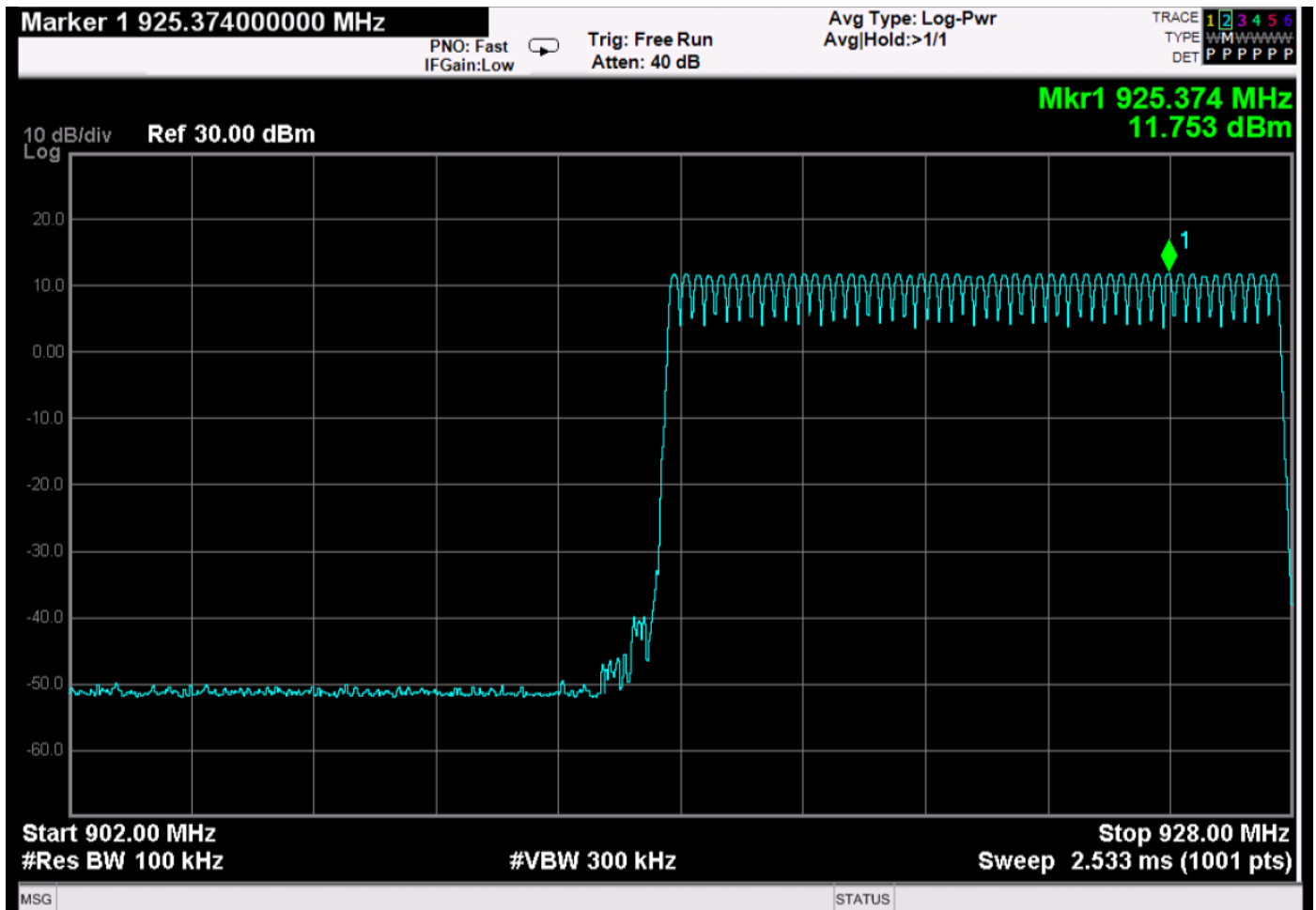

Number of Maximum Channels is 52 – High Band





***TIME OF OCCUPANCY  
DATA SHEETS***

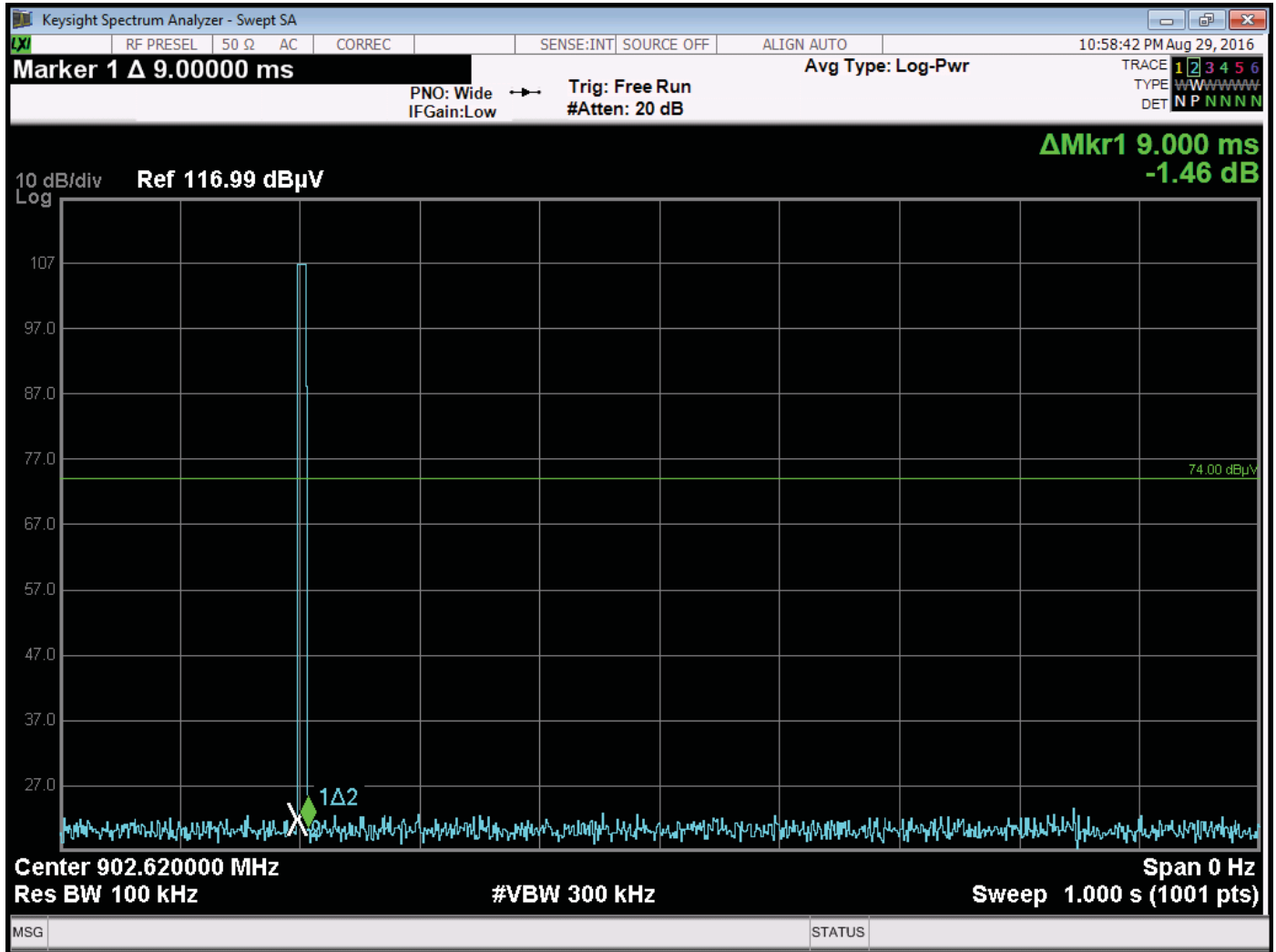

Time of One Pulse – 9 ms

Note: Worst Case Mode of low band hop table used, which results in the pulses appearing more frequently.

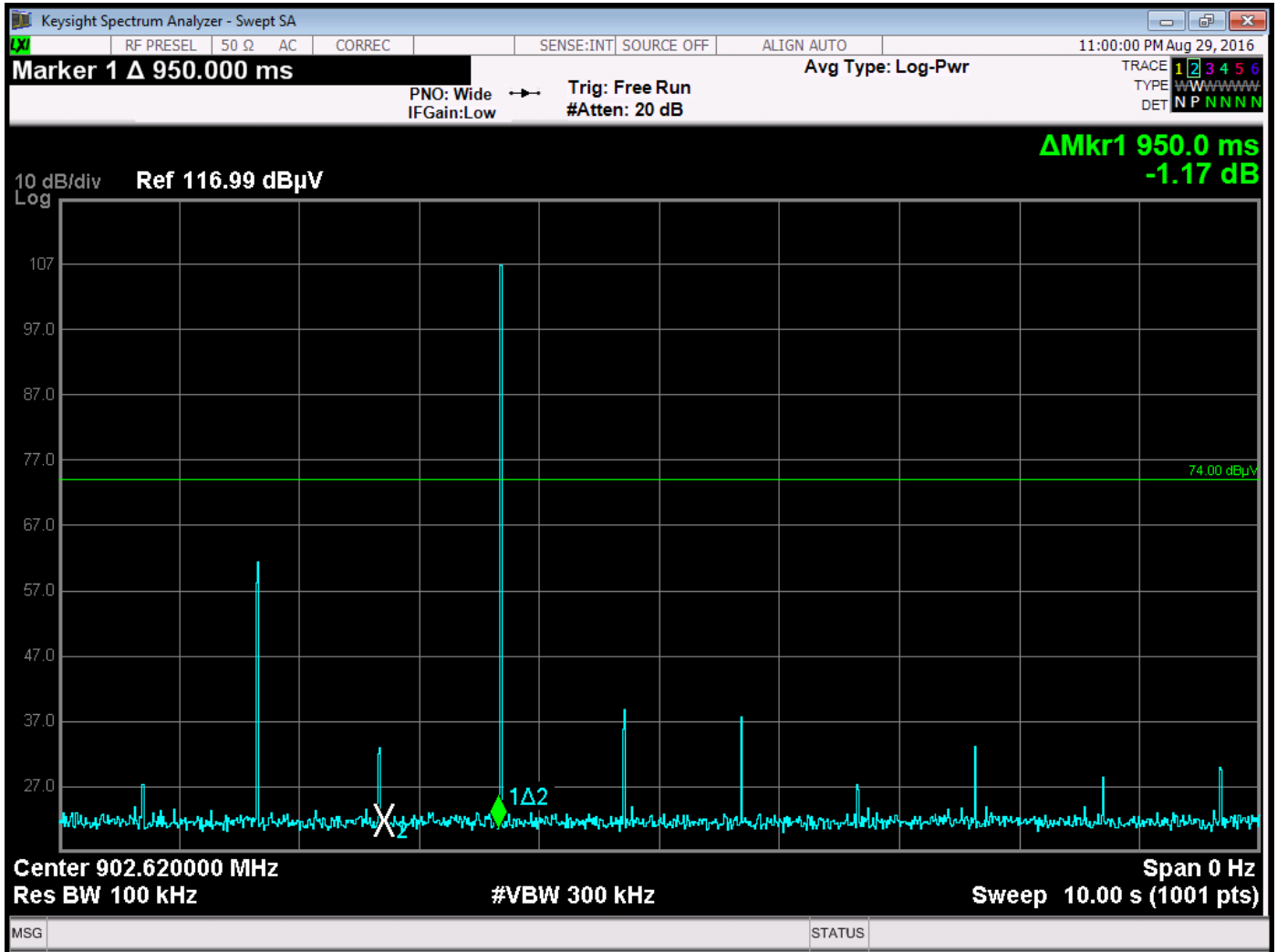

One Pulse Per 10 Seconds  
 Total Time = 18 ms per 20 seconds  
 Limit = 400 ms per 20 seconds  
 Note: Worst Case Mode of low band hop table used, which results in the pulses appearing more frequently.

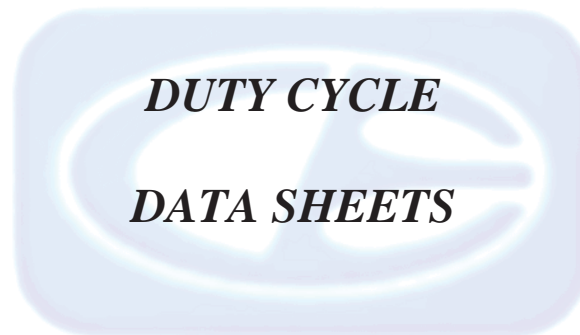

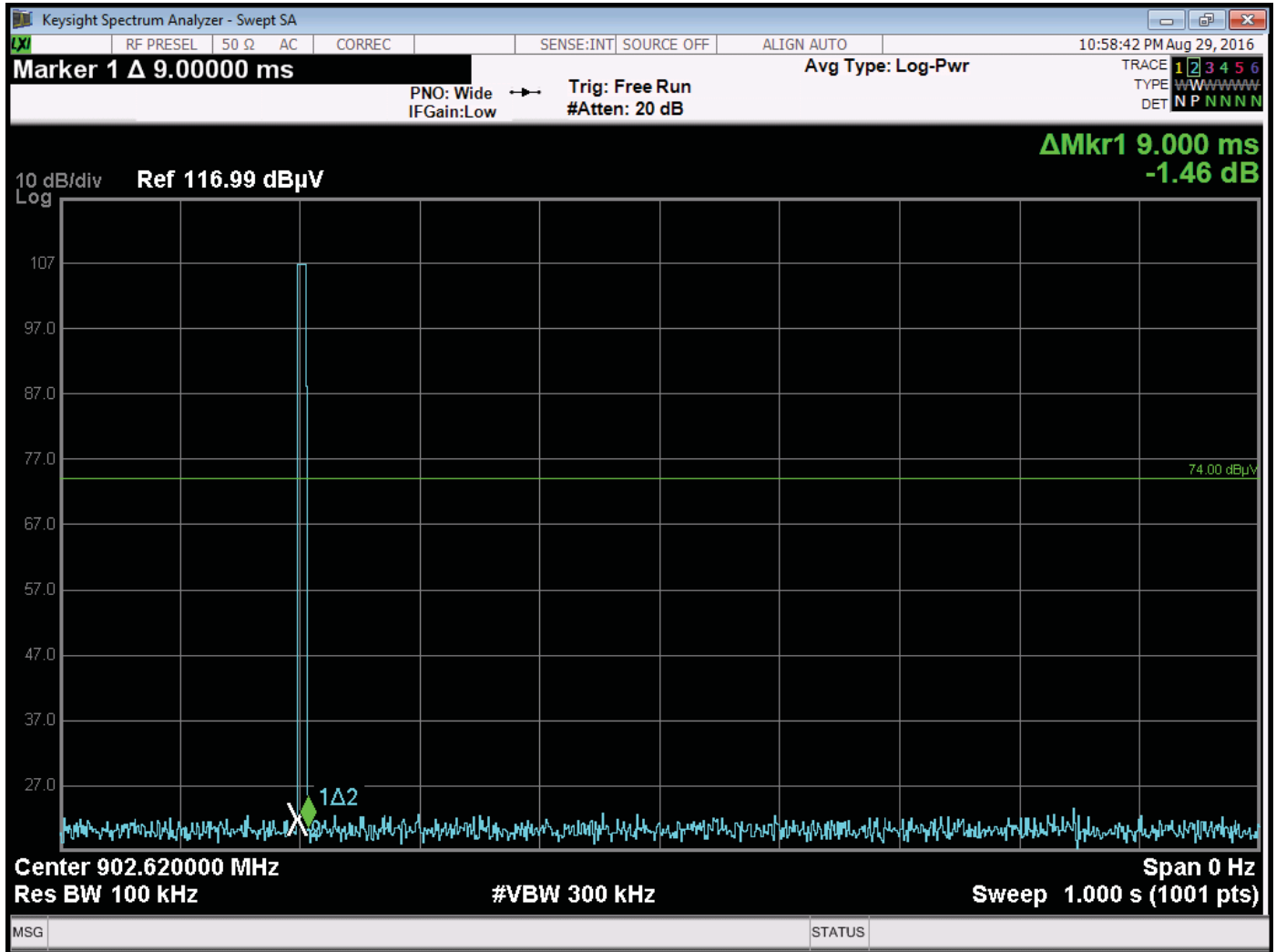

Time of One Pulse – 9 ms

Note: Worst Case Mode of low band hop table used, which results in the pulses appearing more frequently.

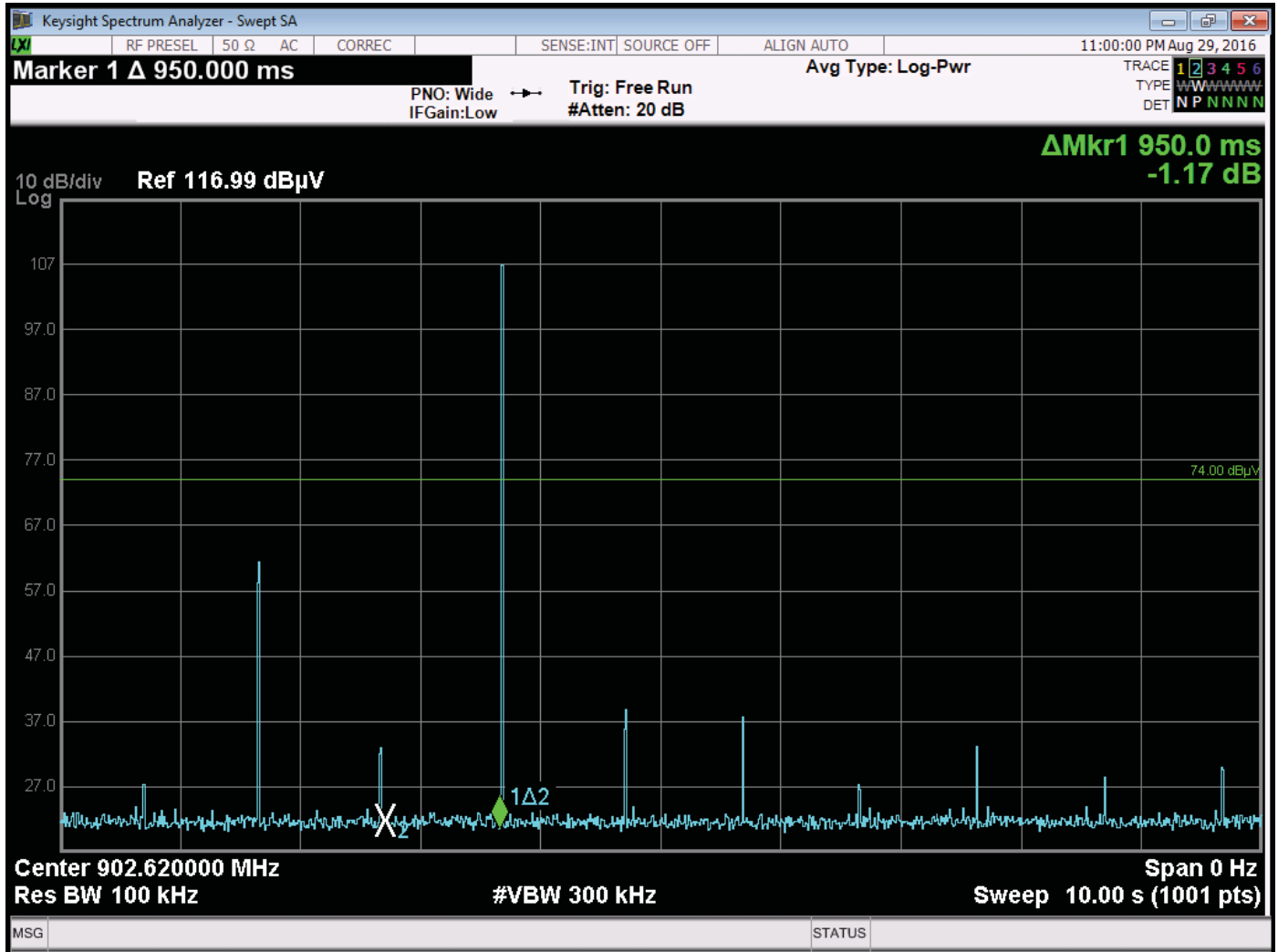

One pulse per 10 Seconds  
 Total duty cycle = 9 ms / 100 ms = 9%  
 Note: Worst Case Mode of low band hop table used, which results in the pulses appearing more frequently.