

FC-302V Radio User Manual



**Address: 6/F,17 Building, Guangqian Industrial Park, Longzhu Road, Xili Town, Nanshan
Shenzhen, China**

Tel: +86-755-86026600 +86-755-23230518

Fax: +86-755-86026300

E-mail: support@friendcom.com

Website: <http://www.friendcom.cn>

Shenzhen Friendcom Technology Development Co., Ltd.

Content

1 Product Description.....	3
2 Technical Specifications	4
3 Interface of the Radio.....	5
3.1 Pin Definition	6
4 Application Instruction.....	7
4.1 Hardware Installation	7
4.2 Operation Instruction.....	8
5 Maintenance and Repair.....	16
5.1 Dimensions	16
5.2 Removing & Replacing the Upper Cover	17
5.3 Removing & Replacing the Power Board & Shield Plate	17
5.4 Removing & Replacing the Main Board	18
5.5 Repairable/Replaceable Parts List	19
6 Accessories Available	20

1 Product Description

FC-302V is a synthesized 5-watt FM transceiver module, which is designed for data transportation and voice communication. For the voice communication, it can support selected pre-emphasis, squelch and audio amplifier. The radio is PLL(Phase Lock Loop Synthesizer) /microprocessor controlled. The application of two-point modulation with good low-frequency response in the radio also makes it a competitive choice for 9600bps rate data application. Compact dimension and wide range DC support make it flexible to use.

Features:

- CE, FCC& AS/NZS 4295: 2004 certified
- Programmable 16 channels with Dip-Switch
- Configurable power save feature
- Optional external channel configuration
- CTCSS/DCS
- Fast start-up time: 5ms
- SQ programmable via PC
- Pocsag Modulation
- PC programmable & Software tune & Calibration

Applications:

- Industrial telemetry & wireless remote control
- Gas and oil flow monitoring
- Electricity, water and gas utilities
- Earthquake, weather, environmental protection and urban lighting control
- Vehicle tracking and asset tracking systems
- Water monitoring, waste water management and irrigation control
- Railway, police, army automation system
- Aerial defense and fire alarm system
- Wireless Paging system

2 Technical Specifications

General Specification		
Working Frequency		136MHz~174MHz
Channel Spacing		6.25KHz/12.5KHz Programmable
Modulation Type		FM
Number of Channels		16
Nominal Working Voltage		12V DC
Extreme Working Voltage		9.5 V~16V DC
Storage Temperature		-40°C ~+80°C
Operating Temperature		-30°C ~+65°C
Current Consumption	Standby	<100mA
	Transmit 5 watts RF Power	<1.5A
	Transmit 1 watt RF Power	<1A
TX to RX Attack Time		<5ms
RX to TX attack time		<5ms
Frequency Error		<2.5ppm
Antenna Connector		BNC 50Ω
External interface		DB15 Female(optional male interface)

Transmitter Specification		
RF Power	6.25KHz Channel Spacing	1W/2W Programmable
	12.5KHz Channel Spacing	1W/2W/3W/4W/5W Programmable
Frequency Deviation	6.25KHz Channel Spacing	<1.25KHz
	12.5KHz Channel Spacing	<2.5KHz
	Subsonic	0.5KHz
Adjacent Channel Power	6.25KHz Channel Spacing	<-60dBc
	12.5KHz Channel Spacing	<-70dBc
Conducted Spurious Emission		<1GHz, <-36dBm >1GHz, <-30dBm
Modulation Sensitivity	Voice	8~15mV
	Data	80~130mV
TX SNR	6.25KHz Channel Spacing	>30dB
	12.5KHz Channel Spacing	>40dB
Receiver Specification		

RX Sensitivity (12dB SINAD)		<-119dBm Extreme<-115dBm
ACS		>70dB
Image Rejection		>70dB
IF Rejection		>70dB
Spurious Rejection		>70dB
Intermodulation Suppression		>65dB
Conducted Spurious Emission		<-57dBm
Receiving Audio Distortion		<5%
RX SNR	6.25KHz Channel Spacing	>30dB
	12.5KHz Channel Spacing	>40dB
Audio Output Power		0.5W @ 8Ωload

3 Interface of the Radio

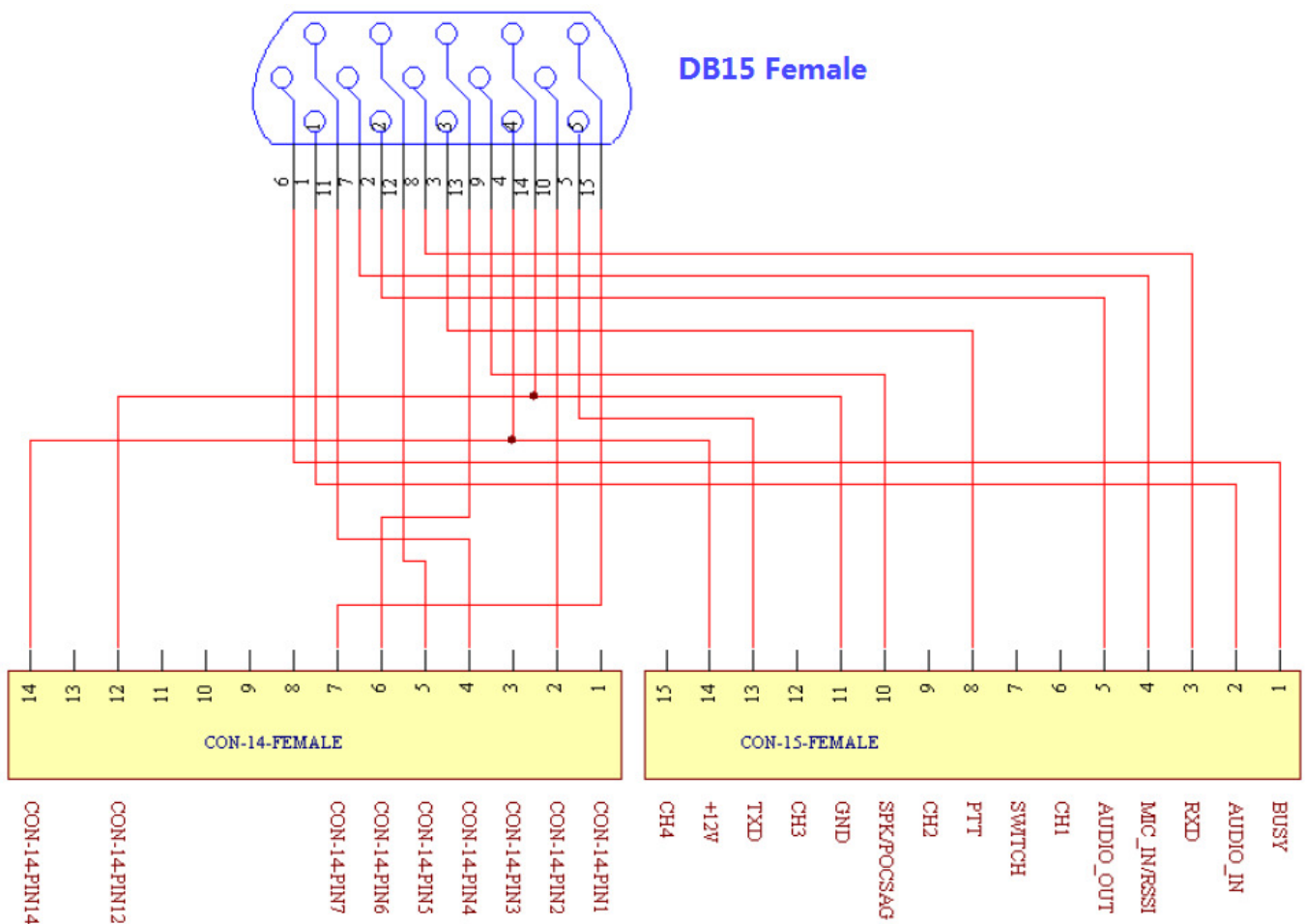

As shown in above picture, the pin definition of CON-14-FEMALE is related with internal devices (Modem board or Bridge board). Refer to Table 1.

Table 1

	Internal bridge
CON-14-PIN1	TFSK
CON-14-PIN2	RXD(RADIO)
CON-14-PIN3	EXT_PTT
CON-14-PIN4	TXD(RADIO)
CON-14-PIN5	RFSK
CON-14-PIN6	TFSK
CON-14-PIN7	EXT_PTT
CON-14-PIN12	GND
CON-14-PIN14	NC

3.1 Pin Assignment

As to FC-302V radio, the pin assignment is shown in Table 2.

Table 2

Pin Name	Pin No.	Description	Remark
AUDIO_IN (MOD IN)	1	Audio input. 3KHz LPF, Modulation sensitivity is 100mV.	AUDIO_IN is effective only when PIN 7(MIC) is vacant or with +5V high level. 3KHz LPF filter existed in audio channel.
AUDIO_OUT (AF OUT)	2	Audio output, 3KHz LPF. Output level at 60% frequency deviation is 250±50mV. This line has an internal pull-up resistor to +5V.	
PTT	3	TX control, active low, only when PTT is active AUDIO_IN and MIC IN are effective. This line has an internal pull- up to 5V.	
B+ (9.5~16V DC)	4	Positive pole input from DC power, nominal +12V.	
PROG (DATA OUT)	5	Programming data output, 5V TTL	
BUSY	6	Logical level output to indicate whether there is a carrier or not. Low lever = carrier, high level=no carrier. This line has a pull-up to +5V.	
MIC IN/RSSI	7	MIC IN: Microphone input. RSSI: To detect the air signal strength. Jumper selectable.	Can directly connect to electrets MIC, the DC voltage of this pin should lower than 3.5V, then MIC transmission can be activated.
PROG (DATA IN)	8	Programming data input, 5V TTL	
SPK/ POCSAG	9	SPK: Audio output from the audio amplifier, @ 8Ω. POCSAG: To transmit POCSAG code. Jumper selectable.	AUDIO_IN is effective only when PIN 7(MIC) is vacant or with +5V high level. 3KHz LPF filter existed in audio channel.
NC	10		
NC	11		
NC	12		
NC	13		
GND	14	Ground	
NC	15		

4 Application Instruction

Functions of PC(Personal Computer) software, hereafter called “FC-302 QuickSet v0.1.12”, will be illustrated. Main goal of this instruction is to save time for user by supporting exact usage of the software, at the same time, give a help to user who wants to utilize the radio for another applications. This programming software enables the various parameters of FC-302V to be read, modified, programmed and printed.

4.1 Hardware Installation

To apply PC software to radio application, FC-302 QuickSet En v0.1.12, programming cable, programming kit and PC are needed. In this chapter, instruction for connection of the equipment will be illustrated.

4.1.1 System Requirements

Computer

Normal personal computer or faster (recommended)

Operating System

Microsoft Windows XP & Windows 7

Communication Port

One available communication port (COM1, 2, 3 or others)

Hardware Accessories

Programming cable(RS232 to USB)

Programming kit

4.1.2 Connecting to Data Radio

Connection between the PC and the radio for parameter setting

The programming kit is used for connection as shown below.



No.	Descriptions
1	DB15 male connector for radio with DB15 female.
2	Power Supply (DC 12V)
3	DB15 female connector for radio with DB15 male.
4	DB9 female connector for RS-232 interface of computer.

The position of the jumper:

For radio's parameter setting, user should put the jumper on the position shown as below.

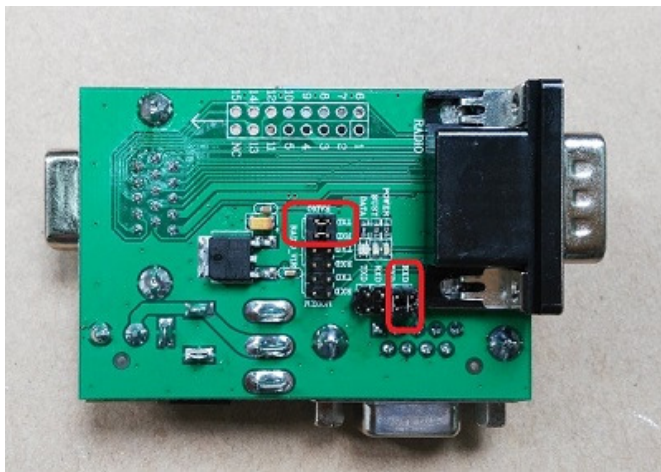

4.2 Operation Instruction

Detailed instruction for channel and system configuration is described. Especially, in input channel data, data input method for Rx,Tx frequency, Rx,Tx option such as CTCSS, DCS, scan and bandwidth is explained specifically. In addition, system option such as selection of squelch type, data value setting for power saving mode, Tx time out time, scan option and modem speed is detailed.

4.2.1 Overall View

Pin 6 (BUSY) and Pin 8 (Switch) of DB15 connector work as TX end and RX end of simulated serial port for data transmission in the first 2 minutes after the radio power on. The CON port is with characteristics of 9600bps, 8N1, TTL. If no valid command is sent from PC, the port will be disabled from serial simulation function and return to normal BUSY and Switch function.

Initially, click on the shortcut of PC software and then the following window shows up.

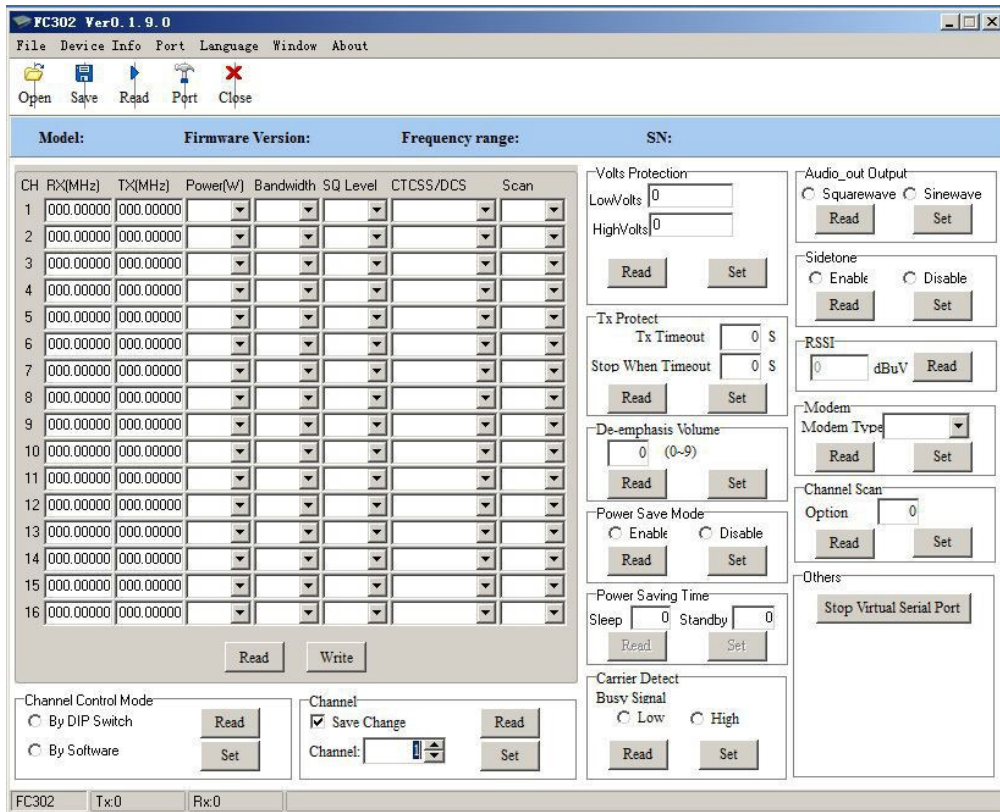

First of all , open the con port. The CON port is with characteristics of 9600bps, 8N1 and click “Open” as picture shows.

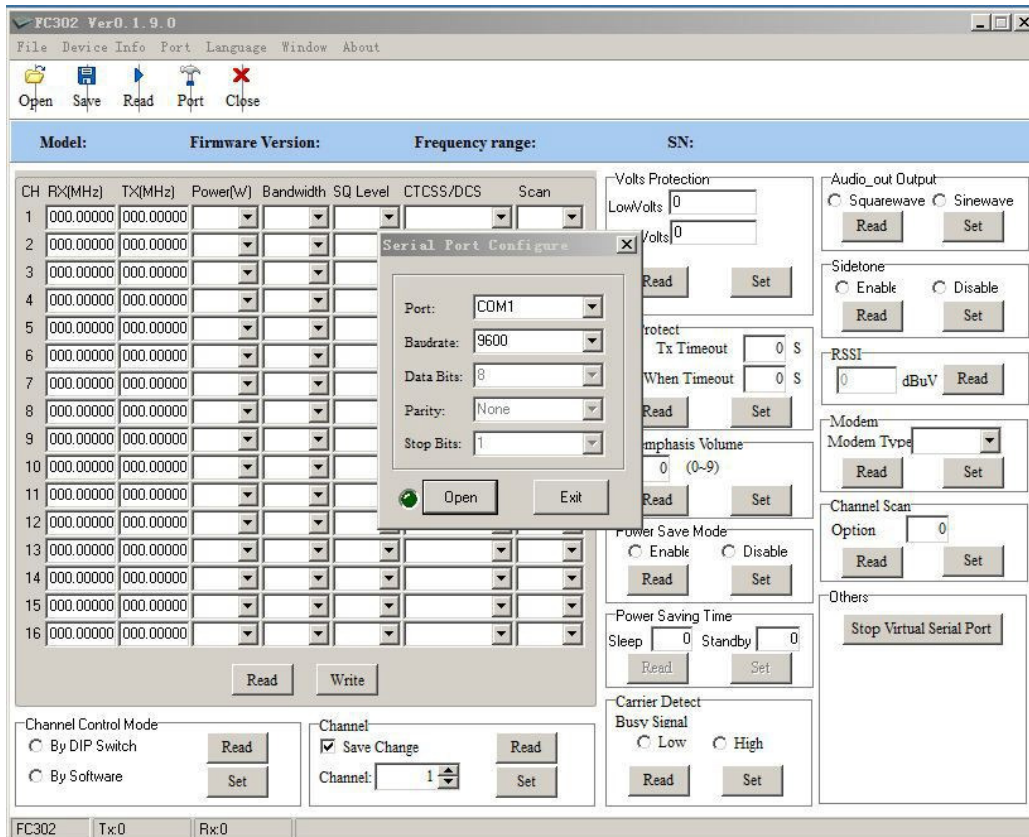

If user puts mouse cursor on the each icon in tool bar for a second, message for function indication is displayed.

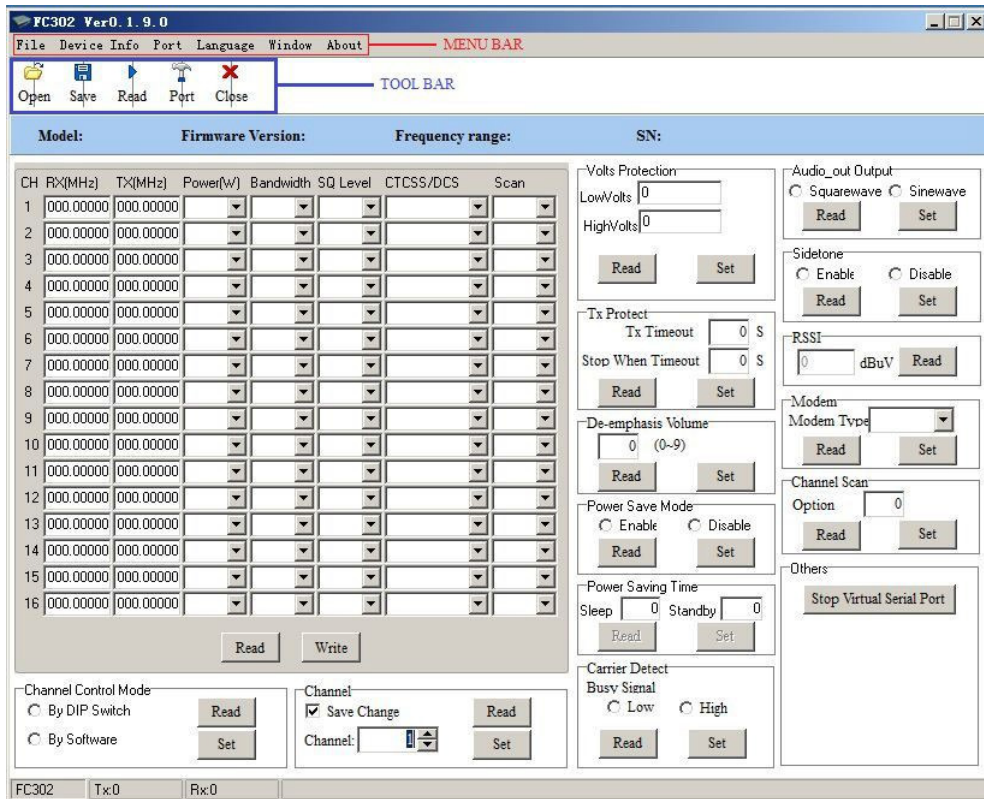

Power on the radio, after 5 seconds, click on the "Read", establish the communication with PC and radio. As the following picture:

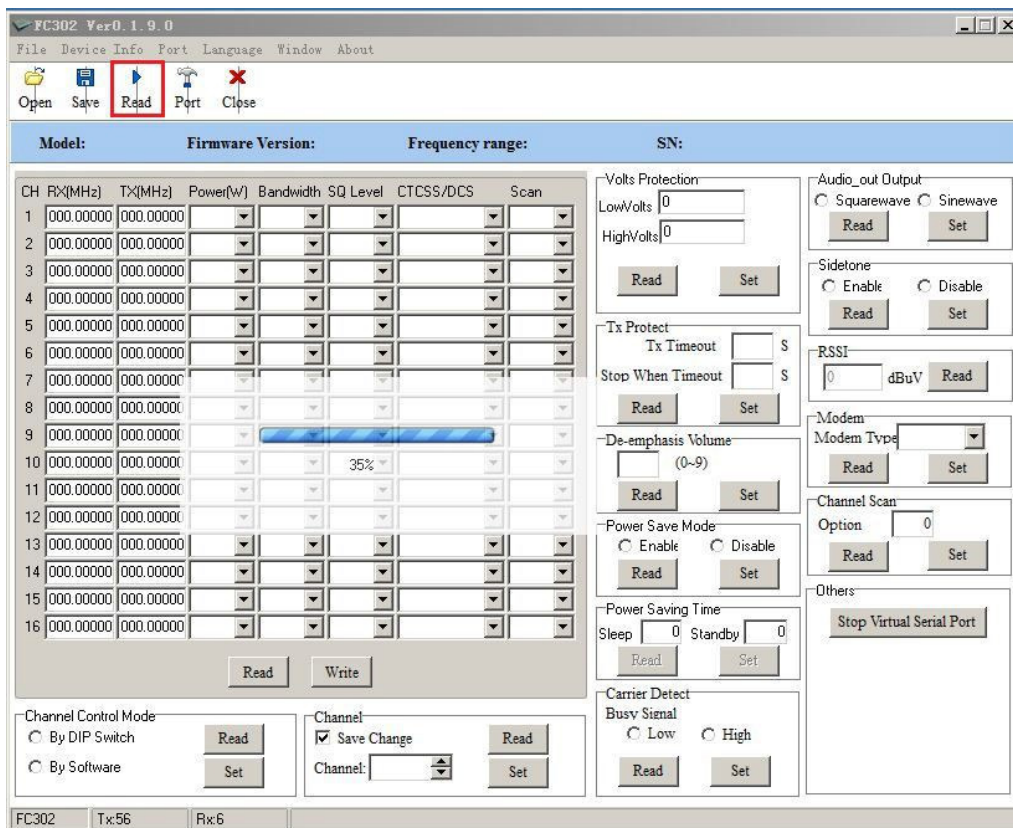

4.2.2 Input Channel Data

In this option part, user can input channel selection from 1 to 16, Rx,Tx frequency, Rx,Tx tone option such as CTCSS, DCS, power, switch and make SCAN list, and choose bandwidth, Narrow or Wide according to each channel.

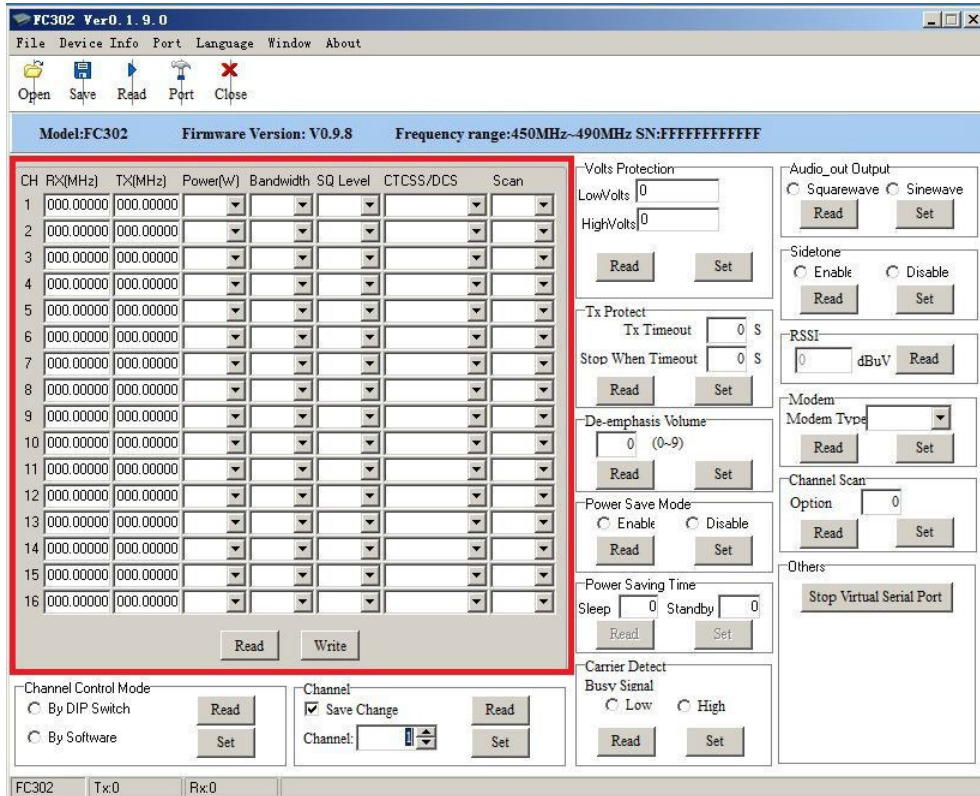

Fig. 4 Feature Column

Double-click on the any window inside red-rectangle area to set Rx,Tx frequency, Rx, Tx option for each channel.

4.2.2.1 Power

CH	RX(MHz)	TX(MHz)	Power(W)
1	150.12500	150.12500	2w
2	150.77500	150.77500	1w
3	000.00000	000.00000	3w
4	000.00000	000.00000	4w
			5w

1-5 output power can be programmable for each channel.

4.2.2.2 Bandwidth



User can decide the channel spacing in this feature with optional 6.25KHz (Narrow) or 12.5KHz (Wide) channel spacing.

4.2.2.3 SQ level



Five SQ levels can be select in our radio.

Level 0 is for fully open mute.

The audio signal will continuously transmit. Other levels with corresponding strength are shown as below:

L1: 0.15uV

L2: 0.25uV

L3: 0.35uV

L4: 0.45uV

L5: 0.55uV

4.2.2.4 CTCSS/DCS and Switch

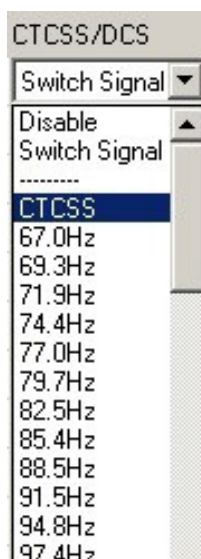

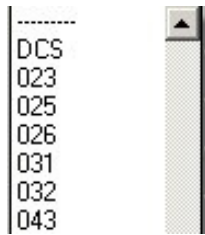

CTCSS/DCS

User can encode tones with CTCSS/DCS according to options shown in the picture. The feature is not available for high speed data transmission.

Switch

When we use radio remote: the Switch function can be use to change a logic from +5V to 0V minimum. The judging condition is long period of 260Hz, sine wave 300 Ms.

4.2.2.5 Scan

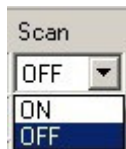

This feature allow user to decide scan mode and establish channel scan list. Radio will start to detect channels and stay on each channel for at least 100ms according to the established scan sequence. If a signal or conversation is detected on any channels in scan list, the radio will stop on that channel and you will monitor the signal or hear the conversation. When the signal or conversation is disappeared, the radio continues to scan.

4.2.3 System Configuration

4.2.3.1 Channel Control Mode

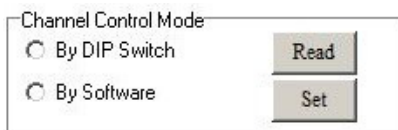

Radio’s channel can be selected by inner Dip(4) switch(HW) or serial command inputted from our PC software(SW). Only in SW control mode, channel can be selected in “Channel” column.

4.4.3.2 Working Channel

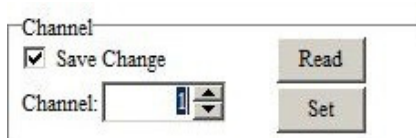

In this column, user select current channel for working.

4.2.3.3 Second Column Features

Volts Protection	
LowVolts	<input type="text" value="0"/>
HighVolts	<input type="text" value="0"/>
<input type="button" value="Read"/>	<input type="button" value="Set"/>
Tx Protect	
Tx Timeout	<input type="text" value="0"/> S
Stop When Timeout	<input type="text" value="0"/> S
<input type="button" value="Read"/>	<input type="button" value="Set"/>
De-emphasis Volume	
<input type="text" value="0"/>	(0-9)
<input type="button" value="Read"/>	<input type="button" value="Set"/>
Power Save Mode	
<input type="radio"/> Enable	<input type="radio"/> Disable
<input type="button" value="Read"/>	<input type="button" value="Set"/>
Power Saving Time	
Sleep	<input type="text" value="0"/>
Standby	<input type="text" value="0"/>
<input type="button" value="Read"/>	<input type="button" value="Set"/>
Carrier Detect	
Busy Signal	
<input type="radio"/> Low	<input type="radio"/> High
<input type="button" value="Read"/>	<input type="button" value="Set"/>

4.2.3.3.1 LED Status Indicator

The LED indicator gives realtime status of the radio's operation. Red for TX, and green for RX.

4.2.3.3.2 TX Protection

This feature, when enabled, limit the amount of time that user can continuously transmit. The time can be set from 1 second to 60 seconds. When timeout, radio will release PTT pinout. If user want to transmit again, he or she have to wait delay time (set by “stop when timeout”) after the radio released PTT.

4.2.3.3.3 De-emphasis Volume

FC-302V radio output voice via SPK Pin with 9 levels volume. User is able to select appropriate volume for the connected external speaker in this feature.

4.2.3.3.4 Power Save Mode

Here, you can enable Power save mode or disable. When enabled, radio will automatically switch between Sleep and Standby to lower power consumption. The time of Sleep and Standby can be set in “Power save time”.

However, for supporting fast attack time between TX and RX, the radio will keep in RX mode and the PLL keep working even in power save mode. Only the intermediate frequency circuit is off.

Power Save Time

When Power save is enable, sleep time can be programmed from 20 to 500 ms in 20ms increment with 1~25 optional values. That means 1 equals to 20 ms, 2 equals to 40ms 25 equal to 500ms

Standby time can also be programmed from 40 to 600 ms in 40ms increment with 1~15 optional values. That means 1 equals to 40ms, 2 equals to 80, 15 equals to 600ms.

4.2.3.3.5 Carrier Detect Busy Signal

This feature is to set active level of BUSY Pin, high or low. The status is transferred to user for the connection with external devices.

4.2.3.4 Third Column Features

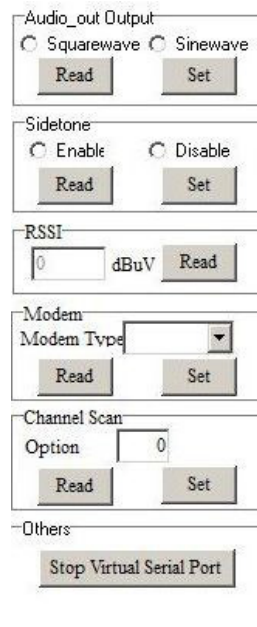

4.2.4.4.1 Audio-out

Output wave for Audio-out can be selected as square wave or sin wave.

4.2.4.4.2. Side Tone

When enabled, user can hear his own voice while transmitting voice. The sidetone volume is fixed at level 2 de-emphasis volume.

4.2.4.4.3 RSSI

To detect the air signal strength over the air;

Unit: dBuV;

4.2.4.4.4 Modem

Setting the signal coupling modes(AC coupling or DC coupling), from the modem baseband signal to the radio analog modulation interface.

4.2.4.4.5 Channel Scan

Scan modes are set up in “Option” and shown as below

0 -----normal scan with carry only

1 -----normal scan, carry with tone

2 -----priority scan, carry only

3 -----priority scan, carry with tone

If normal scan is enabled, radio will scan from initial channel to channel 16 sequentially. If priority scan is enabled, radio will scan the prioritized channel with more times. Prioritized channel is the working channel before the scan. For example, if prioritized channel is CH10 and initial channel is CH8, then the scan sequence is CH8, CH10, CH9, CH10, CH10, CH10, CH11, CH10.....CH16, CH10.

4.2.4.4.6 Others

As mentioned above, the BUSY signal, SWITCH and CTCSS/DCS will only be available after 2 minutes when user finish programming setting. If you click here, user does not need to wait the 2 minutes.

5 Maintenance and Repair

5.1 Dimensions

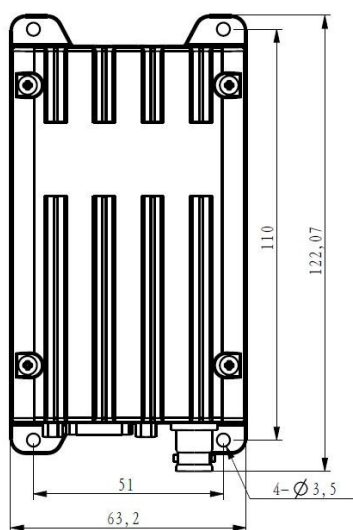

Fig.17 Top View

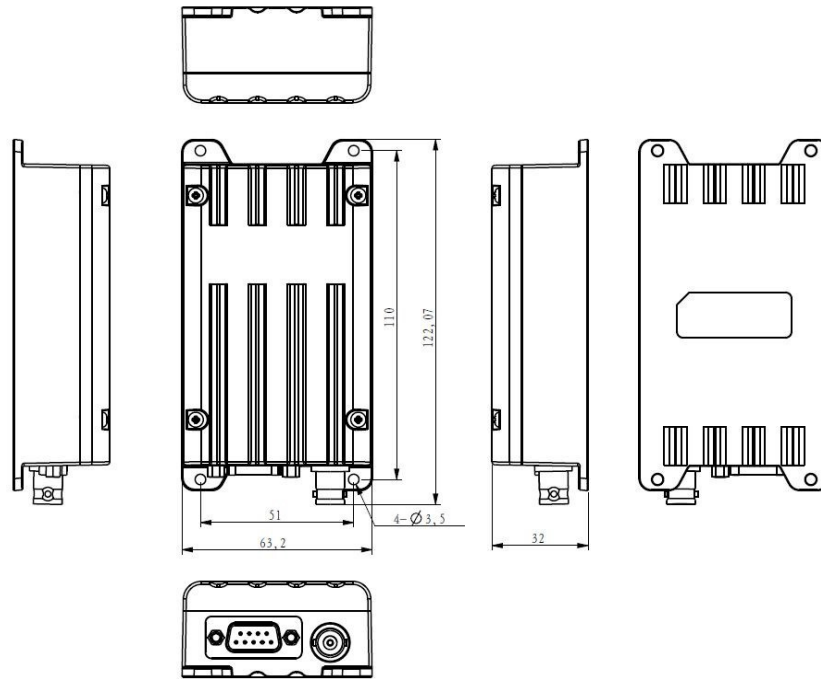

Fig. 18 Exterior View

5.2 Removing & Replacing the Upper Cover

Removing the Upper Cover

1. Unscrew the four upper cover mounting screws located on the upper cover of radio

To replace the Upper Cover

1. Reserve the steps taken to remove the Upper Cover.

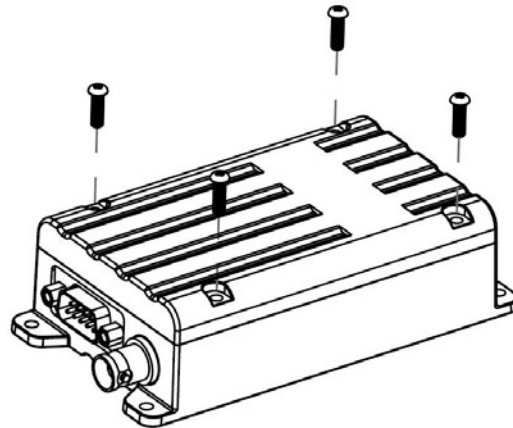

Fig. 19-Upper Cover Removal

5.3 Removing & Replacing the Power Board & Shield Plate

Removing the Power Board & Modem Board Assembly & Shield Plate

- 1 Removing the Upper Cover (refer to Removing & Replacing the Upper Cover)
- 2 Disconnect the DB15 pin connector on CON14.
- 3 Unscrew the 4 mounting screws.
- 4 Remove the Main Board Assembly.

5 Remove the Shield Plate.

To replace the Main board & Power board Assembly:

1. Reserve the steps taken to remove the Main board Assembly & Power board & Shield Plate.

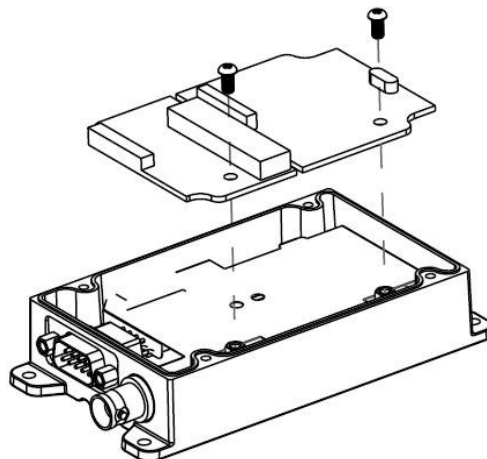

Fig. 20-Power board & Modem board Assembly Removal

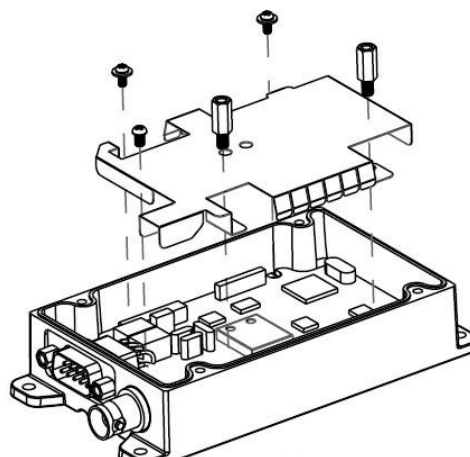

Fig. 21-Shield Plate Assembly Removal

5.4 Removing & Replacing the Main Board

- 1 Remove the Upper Cover (refer to Removing & Replacing the Upper Cover)
- 2 Remove the Power board, Modem Board & Shield Plate
(refer to Removing the Power board & Modem Board Assembly & Shield Plate)
- 3 Unscrew the 4 mounting standoffs.
- 4 Unsolder the antenna connector cable.
- 5 Remove the Main Board Assembly.

To replace the Main Board Assembly:

1. Reverse the steps taken to remove the Main Board Assembly.

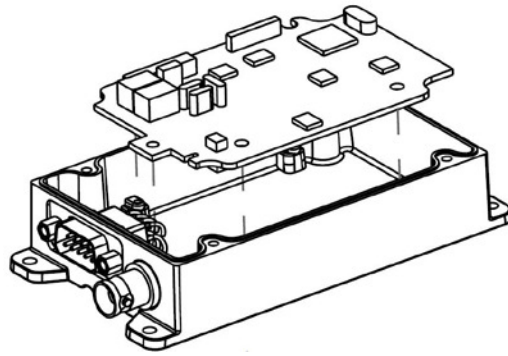

Fig. 21-Main Board Removal

5.5 Repairable/Replaceable Parts List

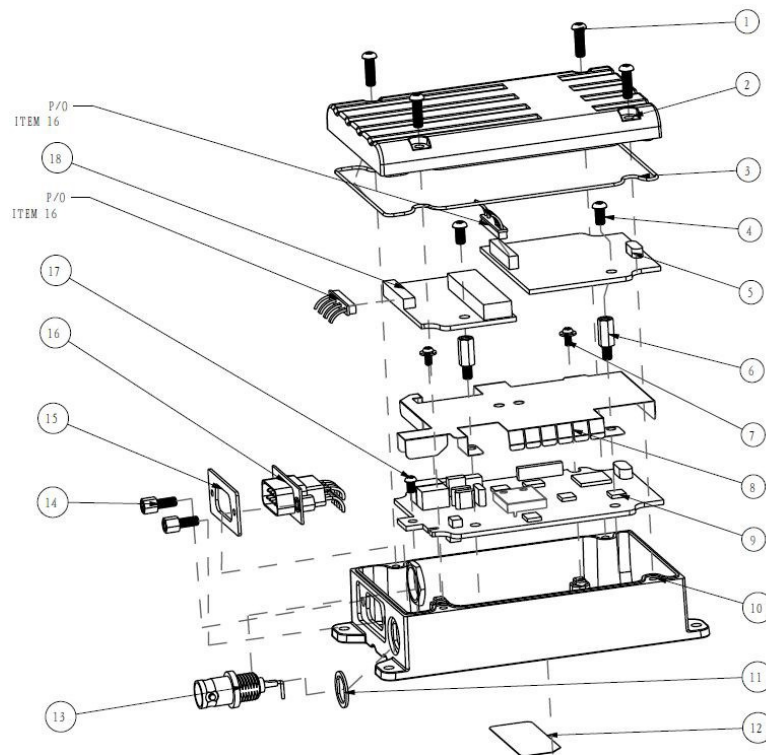

Fig. 22 Exploded View

REPAIRABLE/REPLACEABLE PARTS LIST			
ITEM #	QUANTITY	PART NUMBER	DESCRIPTION
1	4	2.30.0000026600	SCREW, PM3X16
2	1	2.10.0000061300	UPPER COVER
3	1	2.20.0000000058	LID SEALS
4	2	2.30.0000001400	SCREW, PM3X6
5	1	1.50.3021154101	DATA MODEM PCB ASSY
6	2	2.10.0000046000	STANDOFF, HEX, M/F, 9.5+6xM3
7	2	2.30.0000006100	SCREW, PWM2X4
8	1	1.95.0000000157	SHIELD PLATE
9	1	1.50.3021354100	MAIN BOARD PCB ASSY
10	1	2.10.0000061400	BOTTOM COVER
11	1	2.20.0000000057	BNC SEALS
12	1	2.40.0000099000	FCC COMPLIANCE LABEL
13	1	1.72.0000000071	BNC CONNECTOR, 50 OHM
14	2	2.30.0000026700	JACK SCREW
15	1	2.20.0000000056	DB9 SEALS
16	1	1.74.0000000297	D-SUB 9 CONNECTOR
17	1	2.30.0000006700	SCREW, PM2.5X5
18	1	1.50.3021154100	POWER BOARD PCB ASSY

NOTE:

1. BNC CONNECTOR (ITEM 13) INCLUDES ALL NECESSARY TO MOUNT CONNECTOR

6 Accessories Available

Please contact the Friendcom sales team for accessory information.

sales@friendcom.com

Tel: +86 755 23230544

Notice:

FCC Radiation Exposure Statement:

The equipment compliances with RF exposure guidelines. This equipment should be installed and operated with minimum distance 150cm between the radiator & your body, within the range the device supports the highest gain of antenna is 9.0dBi, if the antenna gain over 9.0dBi is not suggested to use within 150cm distance.