

RF TEST REPORT

Test item : Mobile Computer
Model No. : FCC: XM5
IC: XM5WA
Order No. : DTNC1410-04626, DTNC1410-04629
Date of receipt : 2014-10-23
Test duration : 2014-11-03 ~ 2014-11-17
Date of issue : 2014-11-26
Use of report : FCC & IC Original Grant

Applicant : Janam Technologies LLC
100 Crossways Park West Suite 105, Woodbury, New York 11797 USA

Test laboratory : DT&C Co., Ltd.
42, Yurim-ro, 154beon-gil, Cheoin-gu, Yongin-si, Gyeonggi-do, Korea 449-935

Test specification : §22(H), §24(E), RSS-132, RSS-133
Test environment : See appended test report
Test result : Pass Fail

The test results presented in this test report are limited only to the sample supplied by applicant and the use of this test report is inhibited other than its purpose. This test report shall not be reproduced except in full, without the written approval of DIG DT&C Co., Ltd.

Tested by:



Engineer
SeokHwan Hong

Reviewed by:



Technical Manager
HongHee Lee

Test Report Version

Test Report No.	Date	Description
DRTFCC1411-1498	Nov. 26, 2014	Initial issue

Table of Contents

1. GENERAL INFORMATION	4
2. INTRODUCTION	5
2.1. EUT DESCRIPTION.....	5
2.2. MEASURING INSTRUMENT CALIBRATION	5
2.3. TEST FACILITY	5
3. DESCRIPTION OF TESTS.....	6
3.1 ERP & EIRP	6
3.2 PEAK TO AVERAGE RATIO	8
3.3 OCCUPIED BANDWIDTH.	10
3.4 BAND EDGE EMISSIONS AT ANTENNA TERMINAL.....	11
3.5 SPURIOUS AND HARMONIC EMISSIONS AT ANTENNA TERMINAL.....	12
3.6 RADIATED SPURIOUS EMISSIONS	13
3.7 FREQUENCY STABILITY / VARIATION OF AMBIENT TEMPERATURE	14
4. LIST OF TEST EQUIPMENT.....	15
5. SUMMARY OF TEST RESULTS	16
6. SAMPLE CALCULATION	17
7. TEST DATA	18
7.1 EFFECTIVE RADIATED POWER.....	18
7.2 EQUIVALENT ISOTROPIC RADIATED POWER.....	19
7.3 RADIATED SPURIOUS EMISSIONS	20
7.3.1 RADIATED SPURIOUS EMISSIONS (GSM850)	20
7.3.2 RADIATED SPURIOUS EMISSIONS (WCDMA850)	21
7.3.3 RADIATED SPURIOUS EMISSIONS (HSUPA850)	22
7.3.4 RADIATED SPURIOUS EMISSIONS (GSM1900)	23
7.3.5 RADIATED SPURIOUS EMISSIONS (WCDMA1900)	24
7.3.6 RADIATED SPURIOUS EMISSIONS (HSUPA1900).....	25

1. GENERAL INFORMATION

Applicant Name: Janam Technologies LLC

Address: 100 Crossways Park West Suite 105, Woodbury, New York 11797 USA

FCC ID : UTWXM5WA

FCC Classification : Licensed Portable Transmitter Held to Ear (PCE)

EUT : Mobile Computer

Model Name : FCC: XM5
IC: XM5WA

Add Model Name : NA

Supplying power : DC 3.7V

Antenna Information : Internal Antenna
- Type: Built-In type

Tx Frequency : GSM850: 824.2 ~ 848.8 MHz
GSM1900: 1850.2 ~ 1909.8 MHz
EDGE850: 824.2 ~ 848.8 MHz
EDGE1900: 1850.2 ~ 1909.8 MHz
WCDMA850: 826.4 ~ 846.6 MHz
WCDMA1900: 1852.4 ~ 1907.6 MHz
HSUPA850: 826.4 ~ 846.6 MHz
HSUPA1900: 1852.4 ~ 1907.6 MHz

Rx Frequency : GSM850: 869.2 ~ 893.8 MHz
GSM1900: 1930.2 ~ 1989.8 MHz
EDGE850: 869.2 ~ 893.8 MHz
EDGE1900: 1930.2 ~ 1989.8 MHz
WCDMA850: 871.4 ~ 891.6 MHz
WCDMA1900: 1932.4 ~ 1987.6 MHz
HSUPA850: 871.4 ~ 891.6 MHz
HSUPA1900: 1932.4 ~ 1987.6 MHz

Max. RF Output Power : GSM850: 2.296W ERP(33.61dBm)
GSM1900: 1.239W EIRP(30.93dBm)
EDGE850: 0.414W ERP(26.17dBm)
EDGE1900: 0.459W EIRP(26.62dBm)
WCDMA850: 0.247W ERP(23.93dBm)
WCDMA1900: 0.361W EIRP(25.58dBm)
HSUPA850: 0.229W ERP(23.59dBm)
HSUPA1900: 0.344W EIRP(25.36dBm)

Emission Designator(s) : GSM850: 249KGXW
GSM1900: 247KGXW
EDGE850: 235KG7W
EDGE1900: 241KG7W
WCDMA850: 4M15F9W
WCDMA1900: 4M15F9W
HSUPA850: 4M17F9W
HSUPA1900: 4M17F9W

2. INTRODUCTION

2.1. EUT DESCRIPTION

The Equipment Under Test(EUT) supports a GSM/GPRS/EDGE /WCDMA/HSUPA and Bluetooth, 2.4GHz, 5GHz WLAN, NFC.

2.2. MEASURING INSTRUMENT CALIBRATION

The measuring equipment, which was utilized in performing the tests documented herein, has been calibrated in accordance with the manufacturer's recommendations for utilizing calibration equipment, which is traceable to recognized national standards.

2.3. TEST FACILITY

The 3m test site and conducted measurement facility used to collect the radiated data are located at the 38, Yurim-ro, 154beon-gil, Cheoin-gu, Yongin-si, Gyeonggi-do, Korea 449-935. The site is constructed in conformance with the requirements.

- **Semi anechoic chamber registration Number : 165783 (FCC) & 5740A-3 (IC)**

3. DESCRIPTION OF TESTS

3.1 ERP & EIRP

(Effective Radiated Power & Equivalent Isotropic Radiated Power)

Test Set-up

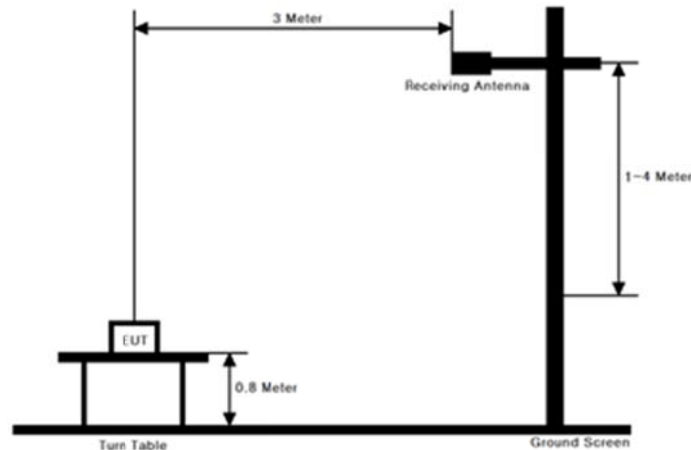

Test Procedure

- ANSI/TIA-603-C-2004 - Section 2.2.17
- KDB971168 v02r01 - Section 5.2.1

These measurements were performed at 3 & 10 m test site. The equipment under test is placed on a non-conductive table 0.8-meters above a turntable which is flush with the ground plane and 3 meters from the receive antenna.

Test setting

1. Set span to at least 1.5 times the OBW.
2. Set RBW = 1-5 % of the OBW, not to exceed 1 MHz.
3. Set VBW $\geq 3 \times$ RBW.
4. Set number of points in sweep $\geq 2 \times$ span / RBW.
5. Sweep time = auto couple.
6. Detector = RMS (power averaging).
7. If the EUT can be configured to transmit continuously (i.e., burst duty cycle ≥ 98 %), then set the trigger to free run.
8. If the EUT cannot be configured to transmit continuously (i.e., burst duty cycle < 98 %), then use a sweep trigger with the level set to enable triggering only on full power bursts and configure the EUT to transmit at full power for the entire duration of each sweep.
Ensure that the sweep time is less than or equal to the transmission burst duration.
9. Trace average at least 100 traces in power averaging (i.e., RMS) mode.
10. Compute the power by integrating the spectrum across the OBW of the signal using the instrument's band power measurement function, with the band limits set equal to the OBW band edges. If the instrument does not have a band power function, then sum the spectrum levels (in linear power units) at intervals equal to the RBW extending across the entire OBW of the spectrum.

The receive antenna height and turntable rotations were adjusted for the highest reading on the receive spectrum analyzer.

A half-wave dipole was substituted in place of the EUT. This dipole antenna was driven by a signal generator and the level of the signal generator was adjusted to obtain the same receive spectrum analyzer reading. The conducted power at the terminal of the substitute antenna is measured.

The ERP/EIRP is calculated using the following formula:

ERP/EIRP = The conducted power at the substitute antenna's terminal [dBm] + Substitute Antenna gain [dBd for ERP , dBi for EIRP]

For readings above 1 GHz, the above procedure is repeated using horn antennas and the difference between the gain of the horn antenna and an isotropic antenna are taken into consideration.

3.2 PEAK TO AVERAGE RATIO

Test set-up

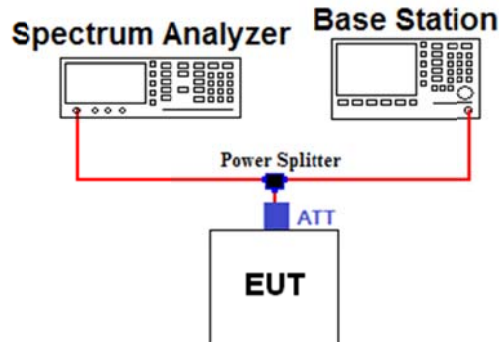

Test Procedure

A peak to average ratio measurement is performed using the following procedure.

■ CCDF Procedure

- KDB971168 v02r01-Section 5.7.1

1. Set resolution/measurement bandwidth \geq signal's occupied bandwidth
2. Set the number of counts to a value that stabilizes the measured CCDF curve
3. Set the measurement interval as follows:
 - 1) For continuous transmissions, set to 1 ms
 - 2) For burst transmissions, employ an external trigger that is synchronized with the EUT burst timing sequence, or use the internal burst trigger with a trigger level that allows the burst to stabilize and set the measurement interval to a time that is less than or equal to the burst duration.
4. Record the maximum PAPR level associated with a probability of 0.1%

■ Alternate Procedure**- KDB971168 v02r01-Section 5.7.2**

Use one of the measurement procedures of the peak power and record as P_{PK} .

Use one of the measurement procedures of the average power and record as P_{Avg} .

Both the peak and average power levels must be expressed in the same logarithmic units (e.g., dBm). Determine the PAPR from:

$$\text{PAPR (dB)} = P_{PK} \text{ (dBm)} - P_{Avg} \text{ (dBm)}.$$

- Peak Power Measurement

1. Set the RBW \geq OBW
2. Set VBW $\geq 3 \times$ RBW
3. Set span $\geq 2 \times$ RBW
4. Sweep time = auto couple
5. Detector = peak
6. Ensure that the number of measurement points \geq span/RBW.
7. Trace mode = max hold
8. Allow trace to fully stabilize.
9. Use the peak marker function to determine the peak amplitude level.

- Average Power Measurement

1. Set span to at least 1.5 times the OBW.
2. Set RBW = 1-5% of the OBW, not to exceed 1 MHz.
3. Set VBW $\geq 3 \times$ RBW.
4. Set number of points in sweep $\geq 2 \times$ span / RBW.
5. Sweep time = auto-couple.
6. Detector = RMS (power averaging).
7. If the EUT can be configured to transmit continuously (i.e., burst duty cycle $\geq 98\%$), then set the trigger to free run.
8. If the EUT cannot be configured to transmit continuously (i.e., burst duty cycle $< 98\%$), then use a sweep trigger with the level set to enable triggering only on full power bursts and configure the EUT to transmit at full power for the entire duration of each sweep. Ensure that the sweep time is less than or equal to the transmission burst duration.
9. Trace average at least 100 traces in power averaging (i.e., RMS) mode.
10. Compute the power by integrating the spectrum across the OBW of the signal using the instrument's band power measurement function, with the band limits set equal to the OBW band edges. If the instrument does not have a band power function, then sum the spectrum levels (in linear power units) at intervals equal to the RBW extending across the entire OBW of the spectrum.

3.3 OCCUPIED BANDWIDTH.

Test set-up

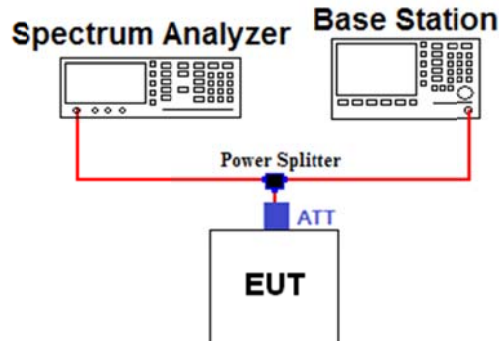

Offset value information

Frequency (MHz)	Offset Value (dB)	Frequency (MHz)	Offset Value (dB)
-	-	-	-
-	-	-	-
-	-	-	-
-	-	-	-
-	-	-	-
-	-	-	-

Note. 1: The offset values from EUT to Spectrum analyzer were measured and used for test.
Offset value = Cable A + Splitter + ATT + Cable B

Test Procedure

- KDB971168 v02r01-Section 4.2

The occupied bandwidth, that is the frequency bandwidth such that, below its lower and above its upper frequency limits, the mean powers radiated are each equal to 0.5 percent of the total mean power of a given emission.

Test setting

1. The signal analyzer's automatic bandwidth measurement capability was used to perform the 99 % occupied bandwidth and the 26 dB bandwidth. The bandwidth measurement was not influenced by any intermediate power nulls in the fundamental emission.
2. RBW = 1 ~ 5 % of the expected OBW & VBW ≥ 3 X RBW
3. Detector = Peak
4. Trance mode = Max hold
5. Sweep = Auto couple
6. The trace was allowed to stabilize
7. If necessary, step 2 ~ 6 were repeated after changing the RBW such that it would be within 1 ~ 5 % of the 99 % occupied bandwidth observed in step 6.

3.4 BAND EDGE EMISSIONS AT ANTENNA TERMINAL.

Test set-up

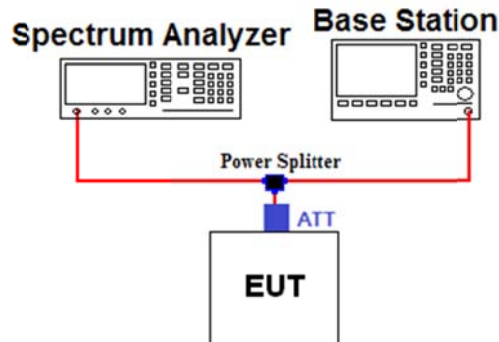

Offset value information

Frequency (MHz)	Offset Value (dB)	Frequency (MHz)	Offset Value (dB)	Frequency (MHz)	Offset Value (dB)
-	-	-	-	-	-
-	-	-	-	-	-
-	-	-	-	-	-
-	-	-	-	-	-

Note. 1: The offset value from EUT to Spectrum analyzer was measured and used for test.
Offset value = Cable A + Splitter + ATT + Cable B

Test Procedure

- KDB971168 v02r01 - Section 6.0

All out of band emissions are measured by means of a calibrated spectrum analyzer. The EUT was setup to maximum output power at its lowest and highest channel with all modulations.

The power of any spurious emission shall be attenuated below the transmitter power (P) by at least $43 + 10 \log(P)$ dB

Test setting

1. Start and stop frequency were set such that the band edge would be placed in the center of the plot
2. Span was set large enough so as to capture all out of band emissions near the band edge
3. RBW ≥ 1 % of the emission
4. VBW $\geq 3 \times$ RBW
5. Detector = RMS & Trace mode = Max hold
6. Sweep time = Auto couple or 1 s for band edge
7. Number of sweep point $\geq 2 \times$ span / RBW
8. The trace was allowed to stabilize

Note 1: In the 1 MHz bands immediately outside and adjacent to the frequency block a resolution bandwidth of **at least one percent** of the emission bandwidth of the fundamental emission of the transmitter may be employed to demonstrate compliance with the out-of-band emissions limit. The emission bandwidth is defined as the width of the signal between two points, one below the carrier center frequency and one above the carrier center frequency, outside of which all emission are attenuated at least 26 dB below the transmitter power.

3.5 SPURIOUS AND HARMONIC EMISSIONS AT ANTENNA TERMINAL.

Test set-up

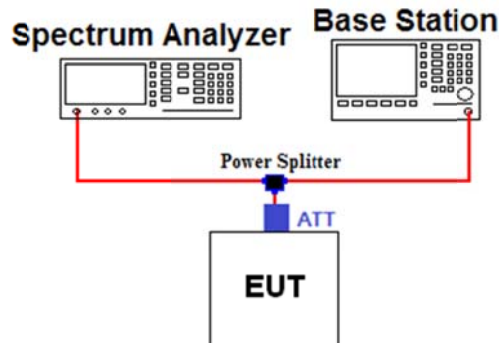

Offset value information

Frequency (MHz)	Offset Value (dB)	Frequency (MHz)	Offset Value (dB)	Frequency (MHz)	Offset Value (dB)
-	-	-	-	-	-
-	-	-	-	-	-
-	-	-	-	-	-
-	-	-	-	-	-

Note. 1: The offset value from EUT to Spectrum analyzer was measured and used for test.
Offset value = Cable A + Splitter + ATT + Cable B

Test Procedure

- KDB971168 v02r01 - Section 6.0

The level of the carrier and the various conducted spurious and harmonic frequencies is measured by means of a calibrated spectrum analyzer. The EUT was setup to maximum output power at its low, middle, high channel with all bandwidths. The spectrum is scanned from 30 MHz up to a frequency including its 10th harmonic.

The power of any spurious emission shall be attenuated below the transmitter power (P) by at least $43 + 10 \log(P)$ dB

Test setting

1. RBW = 100 KHz or 1 MHz & VBW $\geq 3 \times$ RBW (Refer to Note 1)
2. Detector = RMS & Trace mode = Max hold
3. Sweep time = Auto couple
4. Number of sweep point $\geq 2 \times$ span / RBW
5. The trace was allowed to stabilize

Note 1: Compliance with these provisions is based on the use of measurement instrumentation employing a resolution bandwidth of 100 kHz or greater for Part 22 and 1 MHz or greater for Part 24.

3.6 RADIATED SPURIOUS EMISSIONS

Test Set-up

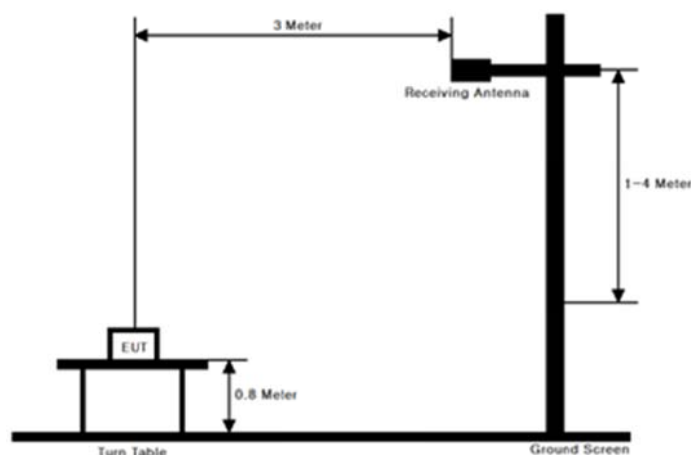

Test Procedure

- ANSI/TIA-603-C-2004 - Section 2.2.12
- KDB971168 v02r01 - Section 5.8

These measurements were performed at 3 & 10m test site. The equipment under test is placed on a non-conductive table 0.8-meters above a turntable which is flush with the ground plane and 3 meters from the receive antenna.

Test setting

1. RBW = 100 kHz for below 1 GHz and 1 MHz for above 1 GHz / VBW \geq 3 X RBW
2. Detector = Peak & Trace mode = Max hold
3. Sweep time = Auto couple
4. Number of sweep point \geq 2 X span / RBW
5. The trace was allowed to stabilize

The receive antenna height and turntable rotations were adjusted for the highest reading on the receive spectrum analyzer.

For radiated power measurements below 1 GHz, a half-wave dipole was substituted in place of the EUT. This dipole antenna was driven by a signal generator and the level of the signal generator was adjusted to obtain the same spectrum analyzer reading.

For radiated power measurements above 1 GHz, a Horn antenna was substituted in place of the EUT. This Horn antenna was driven by a signal generator and the level of the signal generator was adjusted to obtain the same spectrum analyzer reading. The difference between the gain of the horn and an isotropic antenna are taken into consideration.

This measurement was performed with the EUT oriented in 3 orthogonal axis.

3.7 FREQUENCY STABILITY / VARIATION OF AMBIENT TEMPERATURE

Test Set-up

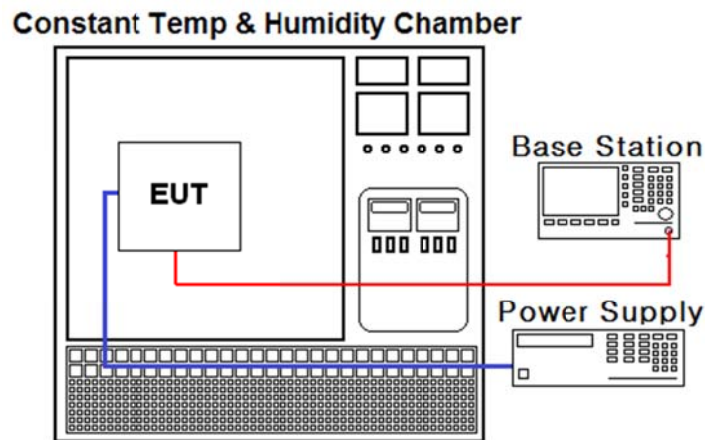

Test Procedure

- ANSI/TIA-603-C-2004
- KDB971168 v02r01 - Section 9.0

The frequency stability of the transmitter is measured by:

a.) **Temperature:**

The temperature is varied from - 30 °C to + 50 °C using an environmental chamber.

b.) **Primary Supply Voltage:**

The primary supply voltage is varied from 85 % to 115 % of the nominal value for non hand-carried battery and AC powered equipment. For hand-carried, battery-powered equipment, primary supply voltage is reduced to the battery operating end point which shall be specified by the manufacturer.

Specification:

The frequency stability shall be sufficient to ensure that the fundamental emission stays within the authorized frequency block for Part 24. The frequency stability of the transmitter shall be maintained within $\pm 0.00025\%$ (± 2.5 ppm) of the center frequency for Part 22.

Time Period and Procedure:

1. The carrier frequency of the transmitter is measured at room temperature.
(25 °C to provide a reference)
2. The equipment is turned on in a "standby" condition for one minute before applying power to the transmitter. Measurement of the carrier frequency of the transmitter is made within one minute after applying power to the transmitter.
3. Frequency measurements are made at 10 °C intervals ranging from -30 °C to +50 °C.
A period of at least one half-hour is provided to allow stabilization of the equipment at each temperature level.

4. LIST OF TEST EQUIPMENT

Type	Manufacturer	Model	Cal.Date (yy/mm/dd)	Next.Cal.Date (yy/mm/dd)	S/N
Spectrum Analyzer	Agilent	E4440A	14/10/21	15/10/21	US45303051
Vector Signal Generator	Rohde Schwarz	SMBV100A	14/01/07	15/01/07	255571
Signal Generator	Rohde Schwarz	SMF100A	14/07/01	15/07/01	102341
PreAmplifier	Agilent	8449B	14/02/27	15/02/27	3008A00370
Amplifier	HP	8447E	14/01/08	15/01/08	2945A02865
Dipole Antenna	Schwarzbeck	VHA9103	13/10/24	15/10/24	2116
Dipole Antenna	Schwarzbeck	VHA9103	14/04/01	16/04/01	2117
Dipole Antenna	Schwarzbeck	UHA9105	13/10/24	15/10/24	2261
Dipole Antenna	Schwarzbeck	UHA9105	14/04/01	16/04/01	2262
Bilog Antenna	Schwarzbeck	VULB9160	14/07/10	16/07/10	3151
HORN ANT	ETS	3115	14/02/26	16/02/26	6419
HORN ANT	ETS	3115	13/02/28	15/02/28	00021097
HORN ANT	A.H.Systems	SAS-574	13/03/20	15/03/20	154
HORN ANT	A.H.Systems	SAS-574	13/05/27	15/05/27	155
High-pass filter	Wainwright	WHKX1.0	14/09/11	15/09/11	9
High-Pass Filter	Wainwright	WHNX2.1	14/09/11	15/09/11	1
8960 Series 10 Wireless Comms Test Set	Agilent	E5515C	14/02/28	15/02/28	GB43461134
Universal Radio Communication Tester	Rohde Schwarz	CMU200	14/02/28	15/02/28	106760
Amplifier	EMPOWER	BBS3Q7ELU	14/09/12	15/09/12	1020
Thermo hygrometer	BODYCOM	BJ5478	14/05/13	15/05/13	120612-2

5. SUMMARY OF TEST RESULTS

FCC Part Section(s)	RSS Section(s)	Parameter	Status Note 1
2.1046	RSS-132 (5.4) RSS-133 (4.1)	Conducted Output Power	C Note 2
22.913(a) 24.232(c)	RSS-132 (5.4) [SRSP-503(5.1.3)] RSS-133 (6.4) [SRSP-510(5.1.2)]	Effective Radiated Power Equivalent Isotropic Radiated Power	C
22.917(a) 24.238(a) 2.1049	RSS-Gen (4.6.1)	Occupied Bandwidth	NA Note 3
22.917(a) 24.238(a) 2.1051	RSS-132 (5.5) RSS-133 (6.5)	Band Edge Spurious and Harmonic Emissions at Antenna Terminal	NA Note 3
24.232(d)	RSS-133 (6.4)	Peak to Average Ratio	NA Note 3
22.917(a) 24.238(a) 2.1053	RSS-132 (5.5) RSS-133 (6.5)	Radiated Spurious and Harmonic Emissions	C
22.355 24.235 2.1055	RSS-132 (5.3) RSS-133 (6.3)	Frequency Stability	NA Note 3

Note 1: **C**=Comply **NC**=Not Comply **NT**=Not Tested **NA**=Not Applicable

Note 2: Refer to RF Exposure Report (Test Report_SAR)

Note 3: These test items were not performed because this device uses the granted module.
(FCCID: QIPPHS8-P)

Please refer to the test report of the granted module.

The module test report number:

- MDE_CINTE_1108_FCCd, MDE_CINTE_1108_FCCe (By 7Layers AG)

The sample was tested according to the following specification:

ANSI/TIA/EIA-603-C-2004 and KDB 971168 D01 v02r01

6. SAMPLE CALCULATION

A. Emission Designator

GSM850 Emission Designator

Emission Designator = **249KGXW**

EDGE850 Emission Designator

Emission Designator = **235KG7W**

WCDMA850 Emission Designator

Emission Designator = **4M15F9W**

HSUPA850 Emission Designator

Emission Designator = **4M17F9W**

GSM1900 Emission Designator

Emission Designator = **247KGXW**

EDGE1900 Emission Designator

Emission Designator = **241KG7W**

WCDMA1900 Emission Designator

Emission Designator = **4M15F9W**

HSUPA1900 Emission Designator

Emission Designator = **4M17F9W**

Note: Emission designators of the granted module were used.

7. TEST DATA

7.1 EFFECTIVE RADIATED POWER

- GSM850 data

CH.	EUT Position (Axis)	Test Conditions(Power Step: 5)						
		Pol. (H/V)	LEVEL@ TX ANTENNA TERMINAL (dBm)	Antenna Gain (dBd)	ERP (dBm)	ERP (W)	Rated Voltage	Note.
824.2 128	Y	V	30.44	1.19	31.63	1.457	DC 3.7V	GSM
836.6 190	Y	V	29.63	1.19	30.82	1.207	DC 3.7V	GSM
848.8 251	Y	V	32.42	1.19	33.61	2.296	DC 3.7V	GSM
848.8 251	Y	V	24.98	1.19	26.17	0.414	DC 3.7V	EDGE

- WCDMA850 data

CH.	EUT Position (Axis)	Test Conditions(TPC bits all set to "1")						
		Pol. (H/V)	LEVEL@ TX ANTENNA TERMINAL (dBm)	Antenna Gain (dBd)	ERP (dBm)	ERP (W)	Rated Voltage	Note.
826.4 4132	Y	V	21.97	1.19	23.16	0.207	DC 3.7V	-
836.6 4183	X	H	21.45	1.19	22.64	0.184	DC 3.7V	-
846.6 4233	X	H	22.74	1.19	23.93	0.247	DC 3.7V	-

- HSUPA850 data

CH.	EUT Position (Axis)	Test Conditions(TPC bits all set to "1")						
		Pol. (H/V)	LEVEL@ TX ANTENNA TERMINAL (dBm)	Antenna Gain (dBd)	ERP (dBm)	ERP (W)	Rated Voltage	Note.
826.4 4132	Y	V	21.48	1.19	22.67	0.185	DC 3.7V	-
836.6 4183	X	H	21.17	1.19	22.36	0.172	DC 3.7V	-
846.6 4233	X	H	22.40	1.19	23.59	0.229	DC 3.7V	-

NOTES:

This EUT was tested under all configurations and the highest power is reported in GSM mode and WCDMA mode with HSDPA inactive at 12.2 kbps RMC and TPC bits set to "1" and in GSM mode using a Power Control Level of "0" in PCS Band and "5" in the Cellular Band. This EUT was tested with the fully charged battery. Also, we have done x, y, z planes in EUT and horizontal and vertical polarization of detecting antenna.

The worst case data is reported.

7.2 EQUIVALENT ISOTROPIC RADIATED POWER**- GSM1900 data**

CH.	EUT Position (Axis)	TEST CONDITIONS(Power Step: 0)						
		Pol. (H/V)	LEVEL@ TX ANTENNA TERMINAL (dBm)	Antenna Gain (dBi)	EIRP (dBm)	EIRP (W)	Rated Voltage	Note.
1850.2 512	Z	V	21.80	8.89	30.69	1.172	DC 3.7V	GSM
1880.0 661	Y	H	21.89	8.92	30.81	1.205	DC 3.7V	GSM
1909.8 810	Z	V	21.97	8.96	30.93	1.239	DC 3.7V	GSM
1909.8 810	Z	V	17.66	8.96	26.62	0.459	DC 3.7V	EDGE

- WCDMA1900 data

CH.	EUT Position (Axis)	Test Conditions(TPC bits all set to "1")						
		Pol. (H/V)	LEVEL@ TX ANTENNA TERMINAL (dBm)	Antenna Gain (dBi)	EIRP (dBm)	EIRP (W)	Rated Voltage	Note.
1850.2 9262	Z	V	16.50	8.89	25.39	0.346	DC 3.7V	-
1880.0 9400	Z	V	16.31	8.92	25.23	0.333	DC 3.7V	-
1909.8 9538	Z	V	16.62	8.96	25.58	0.361	DC 3.7V	-

- HSUPA1900 data

CH.	EUT Position (Axis)	Test Conditions(TPC bits all set to "1")						
		Pol. (H/V)	LEVEL@ TX ANTENNA TERMINAL (dBm)	Antenna Gain (dBi)	EIRP (dBm)	EIRP (W)	Rated Voltage	Note.
1850.2 9262	Z	V	15.98	8.89	24.87	0.307	DC 3.7V	-
1880.0 9400	Z	V	15.85	8.92	24.77	0.300	DC 3.7V	-
1909.8 9538	Z	V	16.40	8.96	25.36	0.344	DC 3.7V	-

NOTES:

This EUT was tested under all configurations and the highest power is reported in GSM mode and WCDMA mode with HSDPA inactive at 12.2 kbps RMC and TPC bits set to "1" and in GSM mode using a Power Control Level of "0" in PCS Band and "5" in the Cellular Band. This EUT was tested with the fully charged battery. Also, we have done x, y, z planes in EUT and horizontal and vertical polarization of detecting antenna.

The worst case data is reported.

7.3 RADIATED SPURIOUS EMISSIONS

7.3.1 RADIATED SPURIOUS EMISSIONS (GSM850)

Channel (ERP)	Freq. (MHz)	EUT Position (Axis)	POL (H/V)	LEVEL@ ANTENNA TERMINAL (dBm)	Substitute Antenna Gain (dBd)	Correct Generator Level (dBm)	Result (dBc)	Limit (dBc)
128 (1.457 W)	1648.47	Y	H	-61.85	6.50	-55.35	86.99	44.63
	2472.40	Y	H	-63.96	7.53	-56.43	88.07	
	-	-	-	-	-	-	-	
190 (1.207 W)	1672.95	Y	H	-61.84	6.53	-55.31	86.13	43.82
	2509.08	Y	H	-64.01	7.57	-56.44	87.26	
	-	-	-	-	-	-	-	
251 (2.296 W)	1697.79	Y	H	-61.80	6.56	-55.24	88.85	46.61
	2546.48	Y	H	-62.09	7.59	-54.50	88.11	
	-	-	-	-	-	-	-	

- Limit Calculation= $43 + 10 \log_{10}(\text{ERP [W]})$ [dBc]

- No other spurious and harmonic emissions were reported greater than listed emissions above table.

NOTES:

This EUT was tested under all configurations and the highest power is reported in GSM mode and WCDMA mode with HSDPA inactive at 12.2 kbps RMC and TPC bits set to "1" and in GSM mode using a Power Control Level of "0" in PCS Band and "5" in the Cellular Band. This EUT was tested with the fully charged battery. Also, we have done x, y, z planes in EUT and horizontal and vertical polarization of detecting antenna.

The worst case data is reported.

7.3.2 RADIATED SPURIOUS EMISSIONS (WCDMA850)

Channel (ERP)	Freq. (MHz)	EUT Position (Axis)	POL (H/V)	LEVEL@ ANTENNA TERMINAL (dBm)	Substitute Antenna Gain (dBd)	Correct Generator Level (dBm)	Result (dBc)	Limit (dBc)
4132 (0.207 W)	1649.74	Y	H	-52.79	6.51	-46.28	69.44	36.16
	-	-	-	-	-	-	-	
	-	-	-	-	-	-	-	
4183 (0.184 W)	1673.34	Y	H	-52.08	6.53	-45.55	68.19	35.64
	-	-	-	-	-	-	-	
	-	-	-	-	-	-	-	
4233 (0.247 W)	1696.77	Y	H	-52.58	6.55	-46.03	69.96	36.93
	-	-	-	-	-	-	-	
	-	-	-	-	-	-	-	

- Limit Calculation= $43 + 10 \log_{10}(ERP [W])$ [dBc]

- No other spurious and harmonic emissions were reported greater than listed emissions above table.

NOTES:

This EUT was tested under all configurations and the highest power is reported in GSM mode and WCDMA mode with HSDPA inactive at 12.2 kbps RMC and TPC bits set to "1" and in GSM mode using a Power Control Level of "0" in PCS Band and "5" in the Cellular Band. This EUT was tested with the fully charged battery. Also, we have done x, y, z planes in EUT and horizontal and vertical polarization of detecting antenna.

The worst case data is reported.

7.3.3 RADIATED SPURIOUS EMISSIONS (HSUPA850)

Channel (ERP)	Freq. (MHz)	EUT Position (Axis)	POL (H/V)	LEVEL@ ANTENNA TERMINAL (dBm)	Substitute Antenna Gain (dBd)	Correct Generator Level (dBm)	Result (dBc)	Limit (dBc)
4132 (0.185 W)	1649.28	Z	V	-55.06	6.50	-48.56	71.23	35.67
	-	-	-	-	-	-	-	
	-	-	-	-	-	-	-	
4183 (0.172 W)	1673.34	Z	V	-54.47	6.53	-47.94	70.30	35.36
	-	-	-	-	-	-	-	
	-	-	-	-	-	-	-	
4233 (0.229 W)	1698.72	Z	V	-54.25	6.56	-47.69	71.28	36.59
	-	-	-	-	-	-	-	
	-	-	-	-	-	-	-	

- Limit Calculation= $43 + 10 \log_{10}(\text{ERP [W]})$ [dBc]

- No other spurious and harmonic emissions were reported greater than listed emissions above table.

NOTES:

This EUT was tested under all configurations and the highest power is reported in GSM mode and WCDMA mode with HSDPA inactive at 12.2 kbps RMC and TPC bits set to "1" and in GSM mode using a Power Control Level of "0" in PCS Band and "5" in the Cellular Band. This EUT was tested with the fully charged battery. Also, we have done x, y, z planes in EUT and horizontal and vertical polarization of detecting antenna.

The worst case data is reported.

7.3.4 RADIATED SPURIOUS EMISSIONS (GSM1900)

Channel (EIRP)	Freq. (MHz)	EUT Position (Axis)	POL (H/V)	LEVEL@ ANTENNA TERMINAL (dBm)	Substitute Antenna Gain (dBi)	Correct Generator Level (dBm)	Result (dBc)	Limit (dBc)
512 (1.172 W)	3700.12	Y	V	-51.95	9.78	-42.17	72.86	43.69
	-	-	-	-	-	-	-	
	-	-	-	-	-	-	-	
	-	-	-	-	-	-	-	
661 (1.205 W)	3759.98	Y	V	-53.33	9.72	-43.61	74.42	43.81
	-	-	-	-	-	-	-	
	-	-	-	-	-	-	-	
	-	-	-	-	-	-	-	
810 (1.239 W)	3819.87	Y	V	-52.31	9.66	-42.65	73.58	43.93
	-	-	-	-	-	-	-	
	-	-	-	-	-	-	-	
	-	-	-	-	-	-	-	

- Limit Calculation = $43 + 10 \log_{10}(\text{EIRP [W]})$ [dBc]

- No other spurious and harmonic emissions were reported greater than listed emissions above table.

NOTES:

This EUT was tested under all configurations and the highest power is reported in GSM mode and WCDMA mode with HSDPA inactive at 12.2 kbps RMC and TPC bits set to "1" and in GSM mode using a Power Control Level of "0" in PCS Band and "5" in the Cellular Band. This EUT was tested with the fully charged battery. Also, we have done x, y, z planes in EUT and horizontal and vertical polarization of detecting antenna.

The worst case data is reported.

7.3.5 RADIATED SPURIOUS EMISSIONS (WCDMA1900)

Channel (EIRP)	Freq. (MHz)	EUT Position (Axis)	POL (H/V)	LEVEL@ ANTENNA TERMINAL (dBm)	Substitute Antenna Gain (dBi)	Correct Generator Level (dBm)	Result (dBc)	Limit (dBc)
9262 (0.346W)	3701.80	Y	H	-42.38	9.78	-32.60	57.99	38.39
	-	-	-	-	-	-	-	
	-	-	-	-	-	-	-	
	-	-	-	-	-	-	-	
9400 (0.333W)	3759.03	Y	H	-43.57	9.72	-33.85	59.08	38.23
	-	-	-	-	-	-	-	
	-	-	-	-	-	-	-	
	-	-	-	-	-	-	-	
9538 (0.361W)	3817.78	X	H	-43.14	9.67	-33.47	59.05	38.58
	-	-	-	-	-	-	-	
	-	-	-	-	-	-	-	
	-	-	-	-	-	-	-	

- Limit Calculation = $43 + 10 \log_{10}(\text{EIRP [W]})$ [dBc]

- No other spurious and harmonic emissions were reported greater than listed emissions above table.

NOTES:

This EUT was tested under all configurations and the highest power is reported in GSM mode and WCDMA mode with HSDPA inactive at 12.2 kbps RMC and TPC bits set to "1" and in GSM mode using a Power Control Level of "0" in PCS Band and "5" in the Cellular Band. This EUT was tested with the fully charged battery. Also, we have done x, y, z planes in EUT and horizontal and vertical polarization of detecting antenna.

The worst case data is reported.

7.3.6 RADIATED SPURIOUS EMISSIONS (HSUPA1900)

Channel (EIRP)	Freq. (MHz)	EUT Position (Axis)	POL (H/V)	LEVEL@ ANTENNA TERMINAL (dBm)	Substitute Antenna Gain (dBi)	Correct Generator Level (dBm)	Result (dBc)	Limit (dBc)
9262 (0.307W)	3701.92	X	H	-42.81	9.78	-33.03	57.90	37.87
	-	-	-	-	-	-	-	
	-	-	-	-	-	-	-	
	-	-	-	-	-	-	-	
9400 (0.300W)	3761.68	X	H	-44.02	9.72	-34.30	59.07	37.77
	-	-	-	-	-	-	-	
	-	-	-	-	-	-	-	
	-	-	-	-	-	-	-	
9538 (0.344W)	3820.42	X	H	-43.47	9.66	-33.81	59.17	38.36
	-	-	-	-	-	-	-	
	-	-	-	-	-	-	-	
	-	-	-	-	-	-	-	

- Limit Calculation = $43 + 10 \log_{10}(\text{EIRP [W]})$ [dBc]

- No other spurious and harmonic emissions were reported greater than listed emissions above table.

NOTES:

This EUT was tested under all configurations and the highest power is reported in GSM mode and WCDMA mode with HSDPA inactive at 12.2 kbps RMC and TPC bits set to "1" and in GSM mode using a Power Control Level of "0" in PCS Band and "5" in the Cellular Band. This EUT was tested with the fully charged battery. Also, we have done x, y, z planes in EUT and horizontal and vertical polarization of detecting antenna. The worst case data is reported.