



FCC Radio Test Report

FCC ID: UTWGT1WA

This report concerns: Original Grant

Project No. : 2312C115
Equipment : GT1 Head Unit
Brand Name : JANAM
Test Model : GT1
Series Model : N/A
Applicant : Janam Technologies LLC
Address : 999 South Oyster Bay Rd
Suite 409
Bethpage, NY 11714
USA
Manufacturer : Janam Technologies LLC
Address : 999 South Oyster Bay Rd
Suite 409
Bethpage, NY 11714
USA
Factory : VGC(SHENZHEN) Technology Co., Ltd
Address : Room 104, No. 1073 Fujin Road, Lougang Community, Songgang
Street, Baoan District, Shenzhen, Guangdong, China
Date of Receipt : Dec. 20, 2023
Date of Test : Dec. 20, 2023 ~ Jan. 10, 2024
Issued Date : Feb. 29, 2024
Report Version : R00
Test Sample : Engineering Sample No.: DG2023122070
Standard(s) : FCC CFR Title 47, Part 15, Subpart C

The above equipment has been tested and found compliance with the requirement of the relative standards by BTL Inc.

Prepared by :

Sheldon Ou

Approved by :

Welly Zhou

Room 108, Building 2, No. 1, Yile Road, Songshan Lake Zone, Dongguan City, Guangdong
523000 China

Tel: +86-769-8318-3000 Web: www.newbtl.com Service mail: btl_qa@newbtl.com

Declaration

BTL represents to the client that testing is done in accordance with standard procedures as applicable and that test instruments used has been calibrated with standards traceable to international standard(s) and/or national standard(s).

BTL's reports apply only to the specific samples tested under conditions. It is manufacture's responsibility to ensure that additional production units of this model are manufactured with the identical electrical and mechanical components. **BTL** shall have no liability for any declarations, inferences or generalizations drawn by the client or others from **BTL** issued reports.

The report must not be used by the client to claim product certification, approval, or endorsement by NVLAP, NIST, or any agency of the U.S. Government.

This report is the confidential property of the client. As a mutual protection to the clients, the public and ourselves, the test report shall not be reproduced, except in full, without our written approval.

BTL's laboratory quality assurance procedures are in compliance with the ISO/IEC 17025: 2017 requirements, and accredited by the conformity assessment authorities listed in this test report.

BTL is not responsible for the sampling stage, so the results only apply to the sample as received.

The information, data and test plan are provided by manufacturer which may affect the validity of results, so it is manufacturer's responsibility to ensure that the apparatus meets the essential requirements of applied standards and in all the possible configurations as representative of its intended use.

Limitation

For the use of the authority's logo is limited unless the Test Standard(s)/Scope(s)/Item(s) mentioned in this test report is (are) included in the conformity assessment authorities acceptance respective.

Please note that the measurement uncertainty is provided for informational purpose only and are not use in determining the Pass/Fail results.

Table of Contents	Page
REPORT ISSUED HISTORY	5
1 . SUMMARY OF TEST RESULTS	6
1.1 TEST FACILITY	7
1.2 MEASUREMENT UNCERTAINTY	7
1.3 TEST ENVIRONMENT CONDITIONS	7
2 . GENERAL INFORMATION	8
2.1 GENERAL DESCRIPTION OF EUT	8
2.2 DESCRIPTION OF TEST MODES	9
2.3 BLOCK DIAGRAM SHOWING THE CONFIGURATION OF SYSTEM TESTED	10
2.4 SUPPORT UNITS	10
3 . AC POWER LINE CONDUCTED EMISSIONS	11
3.1 LIMIT	11
3.2 TEST PROCEDURE	11
3.3 DEVIATION FROM TEST STANDARD	11
3.4 TEST SETUP	12
3.5 EUT OPERATING CONDITIONS	12
3.6 TEST RESULTS	12
4 . RADIATED EMISSION	13
4.1 LIMIT	13
4.2 TEST PROCEDURE	14
4.3 DEVIATION FROM TEST STANDARD	14
4.4 TEST SETUP	15
4.5 EUT OPERATING CONDITIONS	16
4.6 TEST RESULTS - 9 KHZ TO 30 MHZ	16
4.7 TEST RESULTS - 30 MHZ TO 1000 MHZ	16
5 . FREQUENCY TOLERANCE	17
5.1 LIMIT	17
5.2 TEST PROCEDURE	17
5.3 DEVIATION FROM STANDARD	17
5.4 TEST SETUP	17
5.5 EUT OPERATION CONDITIONS	17
5.6 TEST RESULTS	17
6 . BANDWIDTH TEST	18

Table of Contents	Page
6.1 LIMIT	18
6.2 TEST PROCEDURE	18
6.3 DEVIATION FROM STANDARD	18
6.4 TEST SETUP	18
6.5 EUT OPERATION CONDITIONS	18
6.6 TEST RESULTS	18
7 . MEASUREMENT INSTRUMENTS LIST	19
8 . EUT TEST PHOTO	21
APPENDIX A - AC POWER LINE CONDUCTED EMISSIONS	24
APPENDIX B - RADIATED EMISSION - 9 KHZ TO 30 MHZ	27
APPENDIX C - RADIATED EMISSION - 30 MHZ TO 1000 MHZ	32
APPENDIX D - FREQUENCY TOLERANCE	35
APPENDIX E - BANDWIDTH	37

REPORT ISSUED HISTORY

Report No.	Version	Description	Issued Date	Note
BTL-FCCP-1-2312C115	R00	Original Report.	Feb. 29, 2024	Valid

1. APPLICABLE STANDARDS

According to the specifications of the manufacturer, the EUT must comply with the requirements of the following standards:
ANSI C63.10-2013

2. SUMMARY OF TEST RESULTS

Test procedures according to the technical standard(s):

FCC CFR Title 47, Part 15, Subpart C				
Standard(s) Section	Test Item	Test Result	Judgment	Remark
15.207	AC Power Line Conducted Emissions	APPENDIX A	PASS	-----
15.225(a)-(d) 15.205(a) 15.209(a)	Radiated Emission	APPENDIX B APPENDIX C	PASS	-----
15.225(e)	Frequency Tolerance	APPENDIX D	PASS	-----
15.215(c)	Bandwidth	APPENDIX E	PASS	-----
15.203	Antenna Requirement	-----	PASS	Note(2)

Note:

- (1) "N/A" denotes test is not applicable in this test report
- (2) The device what use a permanently attached antenna were considered sufficient to comply with the provisions of 15.203.

2.1 TEST FACILITY

The test facilities used to collect the test data in this report is at the location of No. 3 Jinshagang 1st Rd. Shixia, Dalang Town, Dongguan City, Guangdong 523792.

BTL's Registration Number for FCC: 162128

BTL's Designation Number for FCC: CN5042

2.2 MEASUREMENT UNCERTAINTY

ISO/IEC 17025 requires that an estimate of the measurement uncertainties associated with the emissions test results be included in the report. The measurement uncertainties given below are based on a 95.45% confidence level (based on a coverage factor (k=2))

The BTL measurement uncertainty as below table:

A. AC power line conducted emissions test:

Test Site	Method	Measurement Frequency Range	U,(dB)
DG-C02	CISPR	150kHz ~ 30MHz	2.88

B. Radiated emissions test:

Test Site	Method	Measurement Frequency Range	U,(dB)
DG-CB01	CISPR	9kHz ~ 30MHz	2.36

Test Site	Method	Measurement Frequency Range	Ant. H / V	U,(dB)
DG-CB03 (3m)	CISPR	30MHz ~ 200MHz	V	4.40
		30MHz ~ 200MHz	H	3.62
		200MHz ~ 1,000MHz	V	4.58
		200MHz ~ 1,000MHz	H	3.98

C. Other Measurement test:

Test Item	Uncertainty
Frequency Tolerance	2.7 ppm
Temperature	0.8 °C
Humidity	2.2 %
Bandwidth	0.90 %

Note: Unless specifically mentioned, the uncertainty of measurement has not been taken into account to declare the compliance or non-compliance to the specification.

2.3 TEST ENVIRONMENT CONDITIONS

Test Item	Temperature	Humidity	Test Voltage	Tested By
AC Power Line Conducted Emissions	22°C	53%	AC 120V/60Hz	Hayden Chen
Radiated Emissions-9kHz to 30MHz	18-20°C	46-51%	AC 120V/60Hz	Hayden Chen
Radiated Emissions-30MHz to 1000MHz	23°C	42%	AC 120V/60Hz	Allen Tong
Frequency Tolerance	Normal & Extreme	51%	Normal & Extreme	Parker Yang
Bandwidth	23°C	51%	AC 120V/60Hz	Parker Yang

3. GENERAL INFORMATION

3.1 GENERAL DESCRIPTION OF EUT

Equipment	GT1 Head Unit
Brand Name	JANAM
Test Model	GT1
Series Model	N/A
Model Difference(s)	N/A
Power Source	1# DC Voltage supplied from AC adapter. Model: RC0653-1205000ZP 2# DC Power Supply.
Power Rating	1# I/P: 100-240V~ 50/60Hz 1.5A O/P: 12.0V $\overline{=}$ 5.0A 2# I/P: 12V $\overline{=}$ 5A
Operation Frequency	13.56 MHz
Antenna Type	Loop Antenna

Note:

1. For a more detailed features description, please refer to the manufacturer's specifications or the user's manual.

2. Channel List:

Test Channel	Test Frequency (MHz)
01	13.56

3.2 DESCRIPTION OF TEST MODES

The test system was pre-tested based on the consideration of all possible combinations of EUT operation mode.

Pretest Mode	Description
Mode 1	TX Mode_ 13.56MHz

Following mode(s) was (were) found to be the worst case(s) and selected for the final test.

AC power line conducted emissions test	
Final Test Mode	Description
Mode 1	TX Mode_ 13.56MHz

Radiated emissions test - Below 1GHz	
Final Test Mode	Description
Mode 1	TX Mode_ 13.56MHz

Conducted test	
Final Test Mode	Description
Mode 1	TX Mode_ 13.56MHz

Note:

(1) For radiated emission test, every axis (X, Y, Z) are verified. The test results shown in the following sections represent the worst case emissions.

3.3 BLOCK DIAGRAM SHOWING THE CONFIGURATION OF SYSTEM TESTED

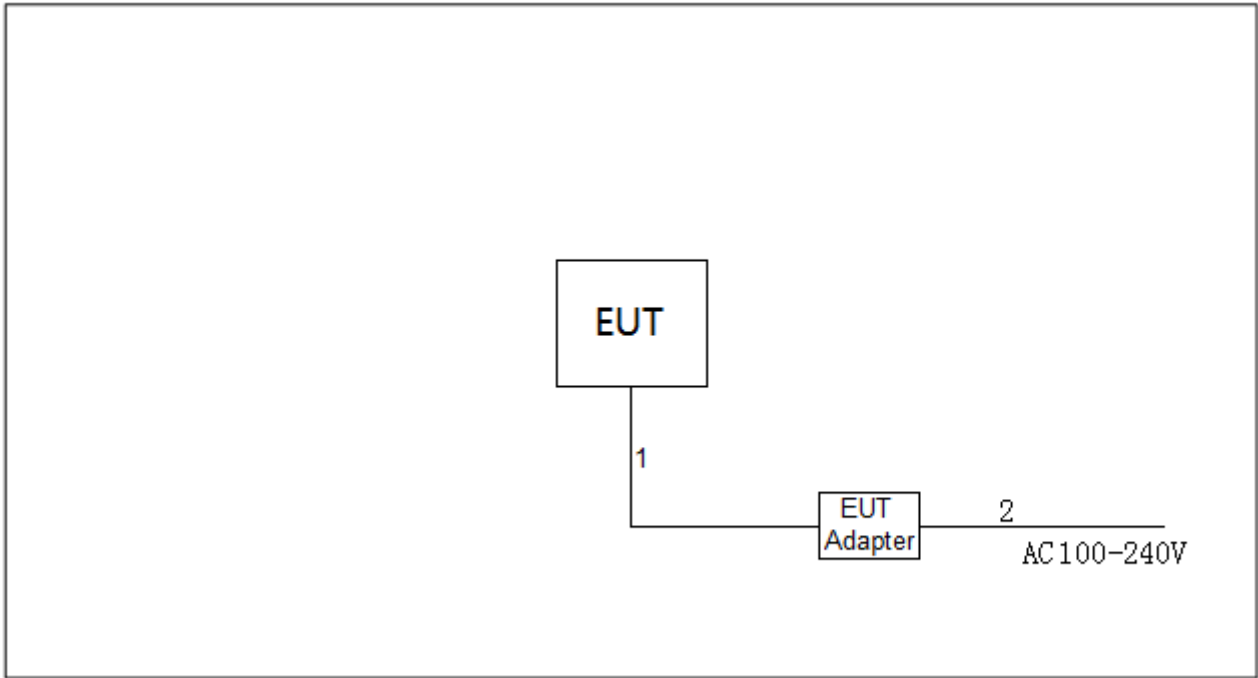

3.4 SUPPORT UNITS

Item	Equipment	Brand	Model No.	Series No.
-	-	-	-	-

Item	Cable Type	Shielded Type	Ferrite Core	Length
1	DC Cable	NO	NO	1.2m
2	AC Cable	NO	NO	1.5m

4. AC POWER LINE CONDUCTED EMISSIONS

4.1 LIMIT

Frequency of Emission (MHz)	Limit (dB μ V)	
	Quasi-peak	Average
0.15 - 0.5	66 to 56*	56 to 46*
0.5 - 5.0	56	46
5.0 - 30.0	60	50

Note:

- (1) The tighter limit applies at the band edges.
- (2) The limit of " * " marked band means the limitation decreases linearly with the logarithm of the frequency in the range.

4.2 TEST PROCEDURE

- a. The EUT was placed 0.8 meters from the horizontal ground plane with EUT being connected to the power mains through a line impedance stabilization network (LISN). All other support equipment powered from additional LISN(s). The LISN provide 50 Ohm/ 50uH of coupling impedance for the measuring instrument.
- b. Interconnecting cables that hang closer than 40 cm to the ground plane shall be folded back and forth in the center forming a bundle 30 to 40 cm long.
- c. I/O cables that are not connected to a peripheral shall be bundled in the center. The end of the cable may be terminated, if required, using the correct terminating impedance. The overall length shall not exceed 1 m.
- d. LISN at least 80 cm from nearest part of EUT chassis.
- e. For the actual test configuration, please refer to the related Item - EUT Test Photos.

The following table is the setting of the receiver

Receiver Parameter	Setting
Start Frequency	0.15 MHz
Stop Frequency	30 MHz
IF Bandwidth	9 kHz

4.3 DEVIATION FROM TEST STANDARD

No deviation.

4.4 TEST SETUP

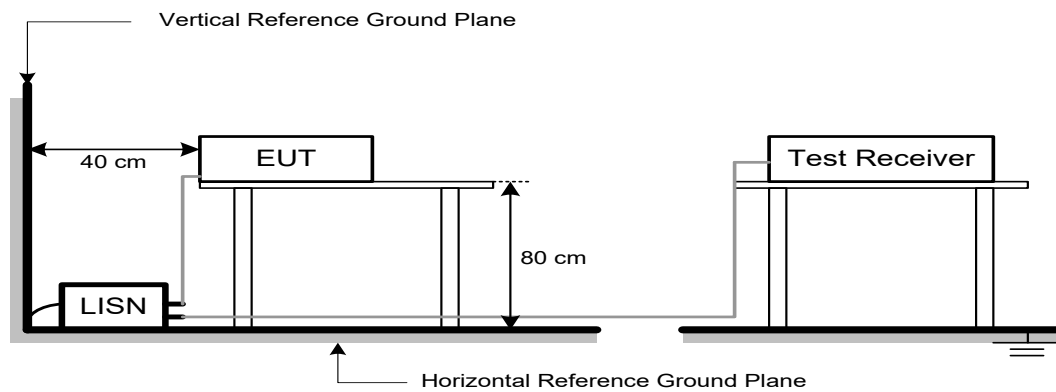

4.5 EUT OPERATING CONDITIONS

The EUT was configured for testing in a typical function (as a customer would normally use it), EUT was programmed to be in continuously transmitting data or hopping on mode.

4.6 TEST RESULTS

Please refer to the APPENDIX A.

Remark:

- (1) All readings are QP Mode value unless otherwise stated AVG in column of 『Note』 . If the QP Mode Measured value compliance with the QP Limits and lower than AVG Limits, the EUT shall be deemed to meet both QP & AVG Limits and then only QP Mode was measured, but AVG Mode didn't perform in this case, a "*" marked in AVG Mode column of Interference Voltage Measured.
- (2) Measuring frequency range from 150 kHz to 30 MHz.

5. RADIATED EMISSION

5.1 LIMIT

§15.225 (a)

The field strength of any emissions within the band 13.553-13.567 MHz shall not exceed 15,848 microvolts/meter at 30 meters.

§15.225 (b)

Within the bands 13.410-13.553 MHz and 13.567-13.710 MHz, the field strength of any emissions shall not exceed 334 microvolts/meter at 30 meters.

§15.225 (c)

Within the bands 13.110-13.410 MHz and 13.710-14.010 MHz the field strength of any emissions shall not exceed 106 microvolts/meter at 30 meters.

§15.225 (d)

The field strength of any emissions appearing outside of the 13.110-14.010 MHz band shall not exceed the general radiated emission limits in §15.209.

§15.209 (a)

Except as provided elsewhere in this subpart, the emissions from an intentional radiator shall not exceed the field strength levels specified in the following table:

LIMITS OF RADIATED EMISSION MEASUREMENT (9 kHz-1000 MHz)

Frequency (MHz)	Field Strength (microvolts/meter)	Measurement Distance (meters)
0.009-0.490	2400/F(kHz)	300
0.490-1.705	24000/F(kHz)	30
1.705-30.0	30	30
30-88	100	3
88-216	150	3
216-960	200	3
Above 960	500	3

Note:

- (1) The limit for radiated test was performed according to FCC CFR Title 47, Part 15, Subpart C.
- (2) The tighter limit applies at the band edges.
- (3) Emission level (dBuV/m)=20log Emission level (uV/m).

5.2 TEST PROCEDURE

The test set-up was made in accordance to the general provisions of ANSI C63.10-2013. The Equipment Under Test (EUT) was set up on a non-conductive table in the semi-anechoic chamber. The test was performed at the distance of 3 m between the EUT and the receiving antenna. The radiated emissions measurements were made in a typical installation configuration.

Sweep the whole frequency band through the range from 9 kHz to the 10th harmonic of the carrier, and the emissions less than 20 dB below the permissible value are reported.

During the test, below 30MHz, the center of the loop shall be 1 meters; above 30MHz, the height of receive antenna shall be moved from 1 to 4 meters, and the antenna shall be performed under horizontal and vertical polarization. The turntable shall be rotated from 0 to 360 degrees for detecting the maximum of radiated spurious signal level. The measurements shall be repeated with orthogonal polarization of the test antenna. The data of cable loss and antenna factor has been calibrated in full testing frequency range before the testing.

Spectrum Parameters	Setting
Start ~ Stop Frequency	9 kHz~150 kHz for RBW 200 Hz
Start ~ Stop Frequency	0.15 MHz~30 MHz for RBW 9 kHz
Start ~ Stop Frequency	30 MHz~1000 MHz for RBW 100 kHz

Receiver Parameters	Setting
Start ~ Stop Frequency	9 kHz~90 kHz for PK/AVG detector
Start ~ Stop Frequency	90 kHz~110 kHz for QP detector
Start ~ Stop Frequency	110 kHz~490 kHz for PK/AVG detector
Start ~ Stop Frequency	490 kHz~30 MHz for QP detector
Start ~ Stop Frequency	30 MHz~1000 MHz for QP detector

The radiated emission was measured in the following position: EUT stand-up position (Z axis), lie-down position (X, Y axis). The worst emission was found in stand-up position (Z axis) and the worst case was recorded.

5.3 DEVIATION FROM TEST STANDARD

No deviation.

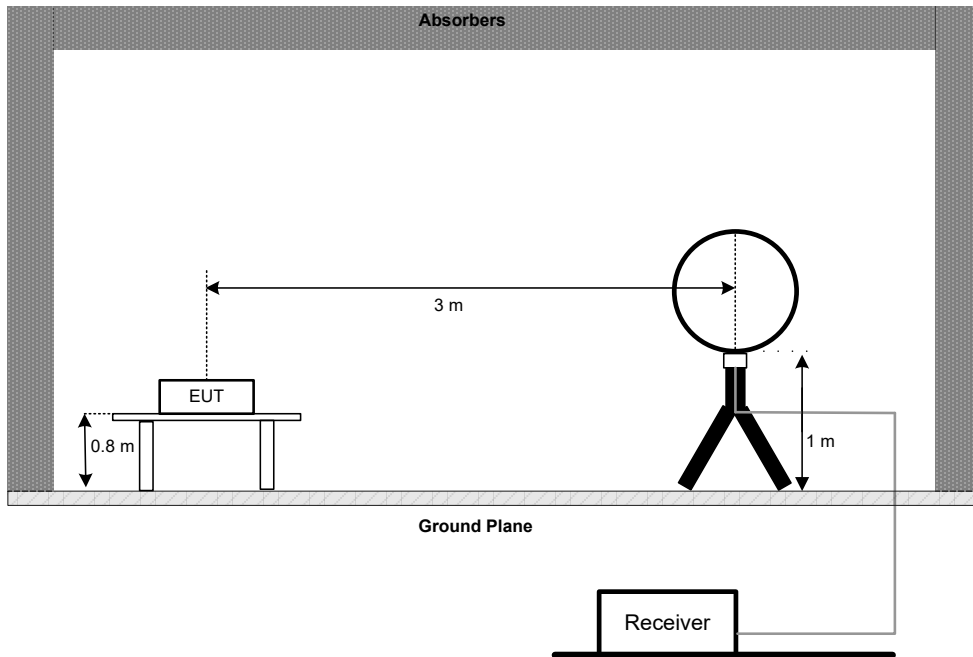
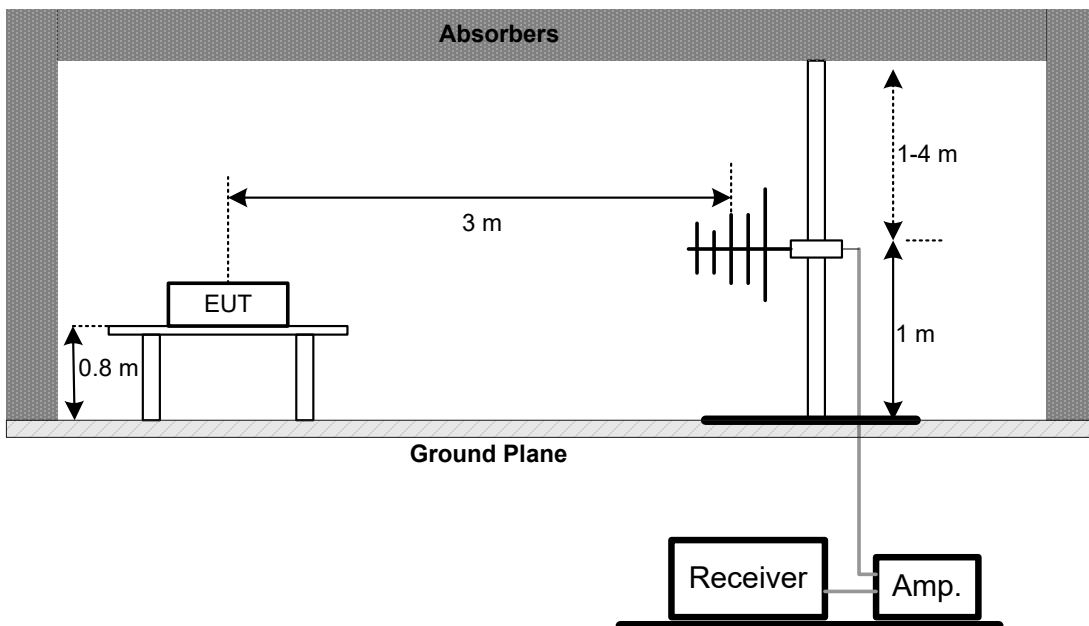
5.4 TEST SETUP**9 kHz to 30 MHz****30 MHz to 1000 MHz**

5.5 EUT OPERATING CONDITIONS

The EUT was programmed to be in continuously transmitting mode.

5.6 TEST RESULTS - 9 kHz TO 30 MHz

Please refer to the APPENDIX B.

Remark:

- (1) Distance extrapolation factor = $40 \log(\text{specific distance} / \text{test distance})$ (dB).
- (2) Limit line = specific limits (dBuV) + distance extrapolation factor.

5.7 TEST RESULTS - 30 MHz TO 1000 MHz

Please refer to the APPENDIX C.

6. FREQUENCY TOLERANCE

6.1 LIMIT

Section	Test Item	Limit
FCC 15.225(e)	Frequency Tolerance	± 1.356 kHz

6.2 TEST PROCEDURE

- a. The frequency tolerance of the carrier signal shall be maintained within $\pm 0.01\%$ of the operating frequency over a temperature variation of -20 degrees to $+ 50$ degrees C at normal supply voltage, and for a variation in the primary supply voltage from 85% to 115% of the rated supply voltage at a temperature of 20 degrees C. For battery operated equipment, the equipment tests shall be performed using a new battery.
- b. Spectrum Setting:

Spectrum Parameter	Setting
Span Frequency	100 kHz
RBW	10 kHz
VBW	30 kHz
Detector	RMS
Trace	Max Hold
Sweep Time	Auto

6.3 DEVIATION FROM STANDARD

No deviation.

6.4 TEST SETUP



6.5 EUT OPERATION CONDITIONS

The EUT tested system was configured as the statements of 4.5 unless otherwise a special operating condition is specified in the follows during the testing.

6.6 TEST RESULTS

Please refer to the APPENDIX D.

7. BANDWIDTH TEST

7.1 LIMIT

Section	Test Item	Limit
15.215(c)	20 dB Bandwidth	-

7.2 TEST PROCEDURE

- The EUT was directly connected to the spectrum analyzer and antenna output port as show in the block diagram below.
- Spectrum Setting:

Spectrum Parameter	Setting
Span Frequency	100 kHz
RBW	10 kHz
VBW	30 kHz
Detector	Peak
Trace	Max Hold
Sweep Time	Auto

7.3 DEVIATION FROM STANDARD

No deviation.

7.4 TEST SETUP



7.5 EUT OPERATION CONDITIONS

The EUT was programmed to be in continuously transmitting mode.

7.6 TEST RESULTS

Please refer to the APPENDIX E.

8. MEASUREMENT INSTRUMENTS LIST

AC Power Line Conducted Emissions					
Item	Kind of Equipment	Manufacturer	Type No.	Serial No.	Calibrated until
1	EMI Test Receiver	R&S	ESR3	103027	Jun. 16, 2024
2	TWO-LINE V-NETWORK	R&S	ENV216	101447	Jan. 07, 2024
3	Measurement Software	Farad	EZ-EMC Ver.NB-03A1-01	N/A	N/A
4	Cable	N/A	SFT205-NMNM-9M-001	9M	Nov. 27, 2024
5	643 Shield Room	ETS	6*4*3	N/A	N/A

Radiated Emissions - 9 kHz to 30 MHz					
Item	Kind of Equipment	Manufacturer	Type No.	Serial No.	Calibrated until
1	Active Loop Antenna	Schwarzbeck	FMZB 1513-60B	1513-60 B-034	Apr. 01, 2024
2	MXE EMI Receiver	Keysight	N9038A	MY56400091	Jan. 07, 2024
3	Cable	N/A	RW2350-3.8A-NMB M-1.5M	N/A	Jun. 10, 2024
4	Measurement Software	Farad	EZ-EMC Ver.NB-03A1-01	N/A	N/A
5	966 Chamber room	ETS	9*6*6	N/A	Jul. 11, 2024

Radiated Emissions - 30 MHz to 1000 MHz					
Item	Kind of Equipment	Manufacturer	Type No.	Serial No.	Calibrated until
1	Trilog-Broadband Antenna	Schwarzbeck	VULB 9168	1462	Dec. 13, 2024
2	Attenuator	EMC INSTRUMENT	EMCI-N-6-06	AT-06009	Dec. 13, 2024
3	Preamplifier	EMC INSTRUMENT	EMC001330	980863	Nov. 17, 2024
4	Cable	RegalWay	LMR400-NMNM-12.5m	N/A	Jul. 04, 2024
5	Cable	RegalWay	LMR400-NMNM-3m	N/A	Jul. 04, 2024
6	Cable	RegalWay	LMR400-NMNM-0.5m	N/A	Jul. 04, 2024
7	Receiver	Agilent	N9038A	MY52130039	Dec. 22, 2024
8	Positioning Controller	MF	MF-7802	N/A	N/A
9	Measurement Software	Farad	EZ-EMC Ver.NB-03A1-01	N/A	N/A
10	966 Chamber room	CM	9*6*6	N/A	May 17, 2024

Frequency Tolerance					
Item	Kind of Equipment	Manufacturer	Type No.	Serial No.	Calibrated until
1	Spectrum Analyzer	R&S	FSP40	100185	Jun. 16, 2024
2	Contact type voltage regulator	SAKO	TDGC2	N/A	Jul. 07, 2024
3	Table top type high and low temperature test chamber	CEPREI	CEEC-M64T-40	15-008	Jan. 07, 2024
4	PCB antenna	N/A	N/A	N/A	N/A
5	DC Block	N/A	N/A	N/A	N/A

Bandwidth					
Item	Kind of Equipment	Manufacturer	Type No.	Serial No.	Calibrated until
1	Spectrum Analyzer	R&S	FSP40	100185	Jun. 16, 2024
2	PCB antenna	N/A	N/A	N/A	N/A

Remark "N/A" denotes no model name, serial no. or calibration specified.
All calibration period of equipment list is one year.

9. EUT TEST PHOTO**AC Power Line Conducted Emissions Test Photos**

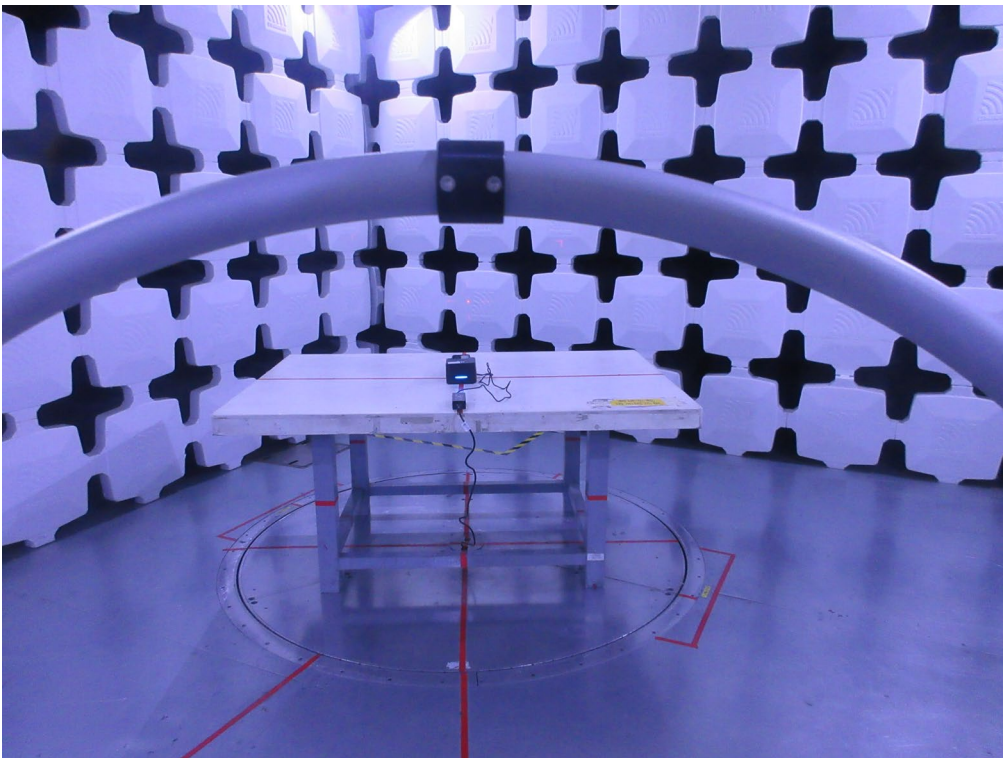
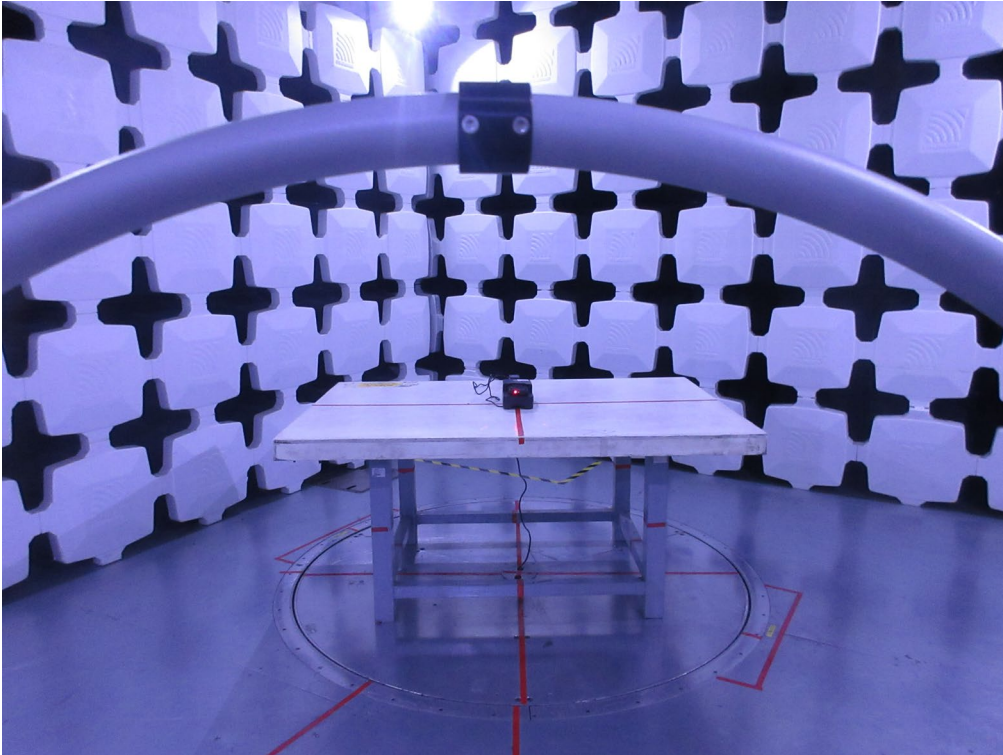
Radiated Emissions Test Photos**9 kHz to 30 MHz**

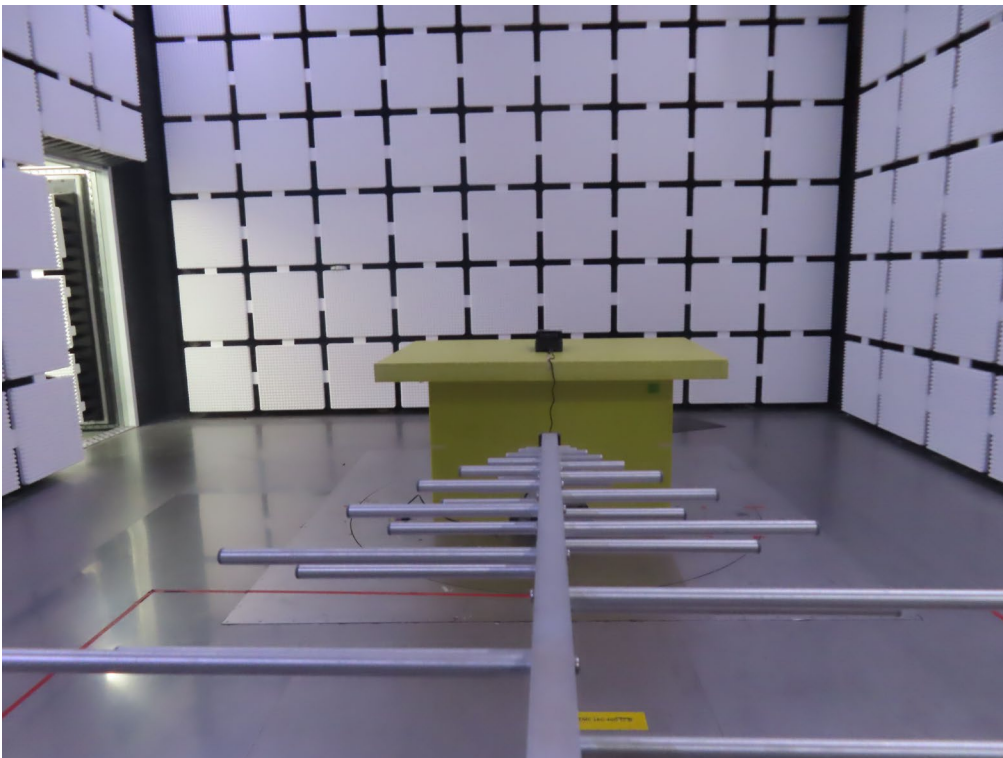
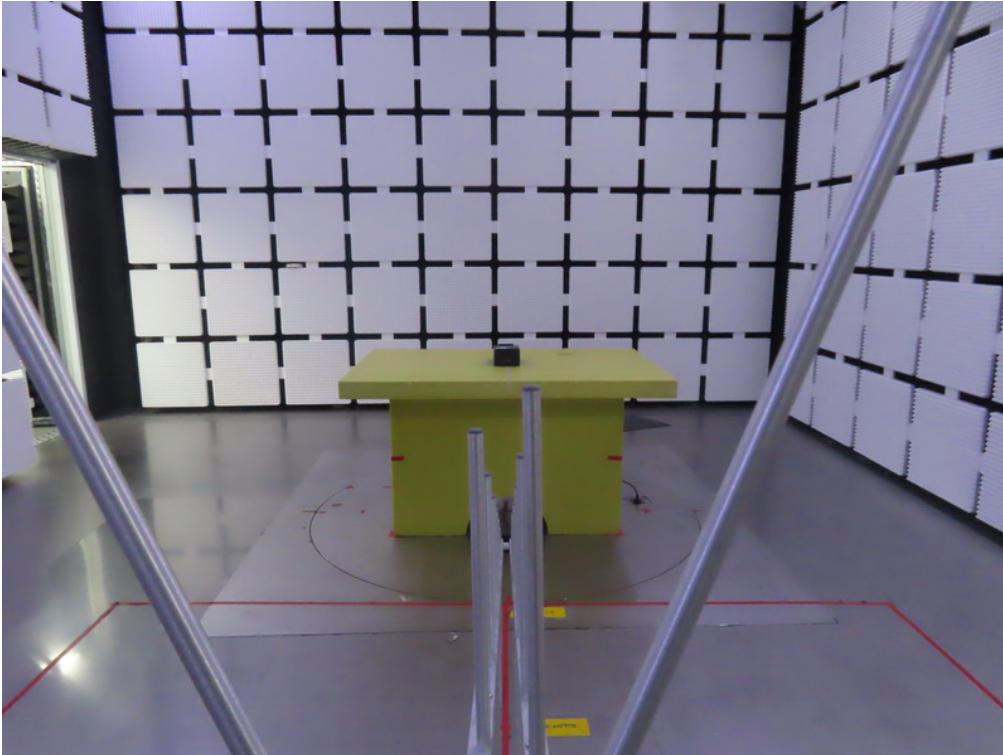
Radiated Emissions Test Photos**30 MHz to 1000 MHz**

APPENDIX A - AC POWER LINE CONDUCTED EMISSIONS

Test Mode	TX Mode_ 13.56MHz	Phase	Line
-----------	-------------------	-------	------

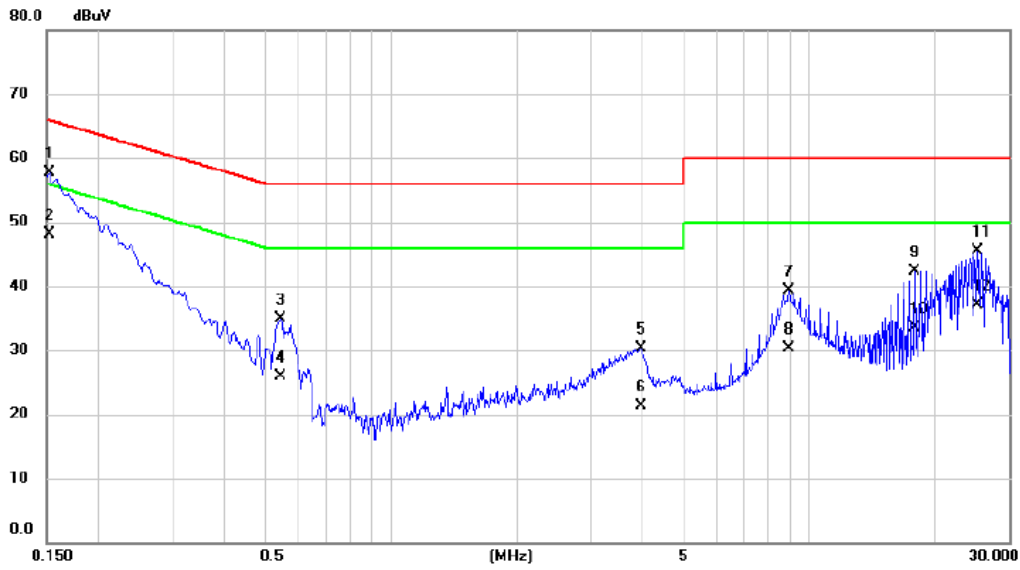

No.	Mk.	Freq.	Reading Level	Correct Factor	Measurement	Limit	Margin	Detector	Comment
		MHz	dBuV	dB	dBuV	dBuV	dB		
1		0.1522	47.92	9.69	57.61	65.88	-8.27	QP	
2	*	0.1522	38.40	9.69	48.09	55.88	-7.79	AVG	
3		0.5437	25.29	9.70	34.99	56.00	-21.01	QP	
4		0.5437	16.30	9.70	26.00	46.00	-20.00	AVG	
5		3.9705	20.57	9.82	30.39	56.00	-25.61	QP	
6		3.9705	11.50	9.82	21.32	46.00	-24.68	AVG	
7		8.9475	29.44	9.96	39.40	60.00	-20.60	QP	
8		8.9475	20.30	9.96	30.26	50.00	-19.74	AVG	
9		17.8980	32.13	10.18	42.31	60.00	-17.69	QP	
10		17.8980	23.40	10.18	33.58	50.00	-16.42	AVG	
11		25.2173	35.00	10.41	45.41	60.00	-14.59	QP	
12		25.2173	26.70	10.41	37.11	50.00	-12.89	AVG	

REMARKS:

(1) Measurement Value = Reading Level + Correct Factor.

(2) Margin Level = Measurement Value - Limit Value.

Test Mode	TX Mode_ 13.56MHz	Phase	Neutral
-----------	-------------------	-------	---------

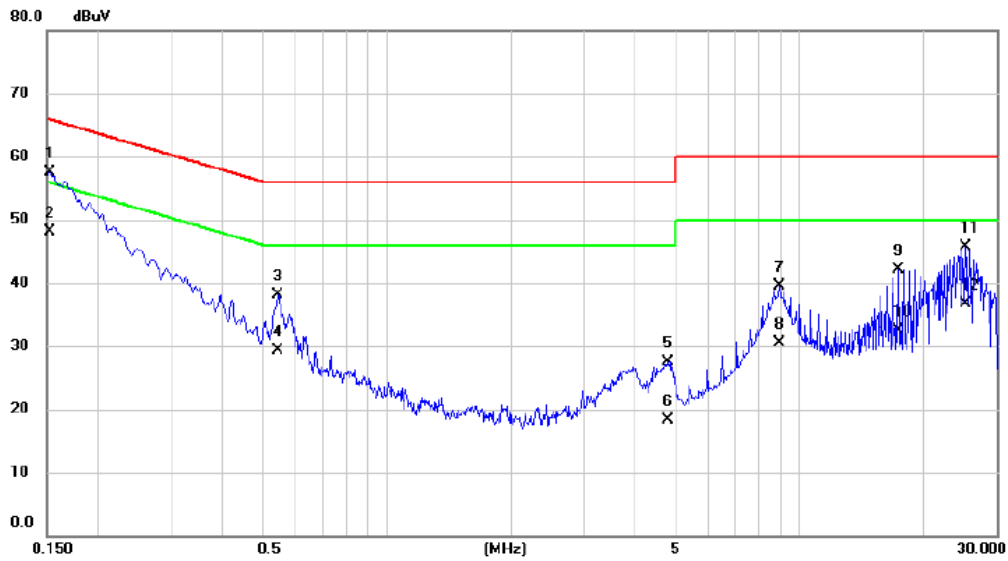

No.	Mk.	Freq. MHz	Reading Level dBuV	Correct Factor dB	Measure- ment dBuV	Limit dBuV	Margin dB	Detector	Comment
1		0.1522	47.88	9.66	57.54	65.88	-8.34	QP	
2	*	0.1522	38.40	9.66	48.06	55.88	-7.82	AVG	
3		0.5460	28.41	9.66	38.07	56.00	-17.93	QP	
4		0.5460	19.60	9.66	29.26	46.00	-16.74	AVG	
5		4.7828	17.67	9.81	27.48	56.00	-28.52	QP	
6		4.7828	8.40	9.81	18.21	46.00	-27.79	AVG	
7		8.9475	29.48	9.94	39.42	60.00	-20.58	QP	
8		8.9475	20.50	9.94	30.44	50.00	-19.56	AVG	
9		17.3558	31.96	10.15	42.11	60.00	-17.89	QP	
10		17.3558	22.30	10.15	32.45	50.00	-17.55	AVG	
11		25.2218	35.24	10.40	45.64	60.00	-14.36	QP	
12		25.2218	26.40	10.40	36.80	50.00	-13.20	AVG	

REMARKS:

- (1) Measurement Value = Reading Level + Correct Factor.
- (2) Margin Level = Measurement Value - Limit Value.

APPENDIX B - RADIATED EMISSION - 9 KHZ TO 30 MHZ

Test Mode	TX Mode_ 13.56MHz	Polarization	Ant 0°
-----------	-------------------	--------------	--------

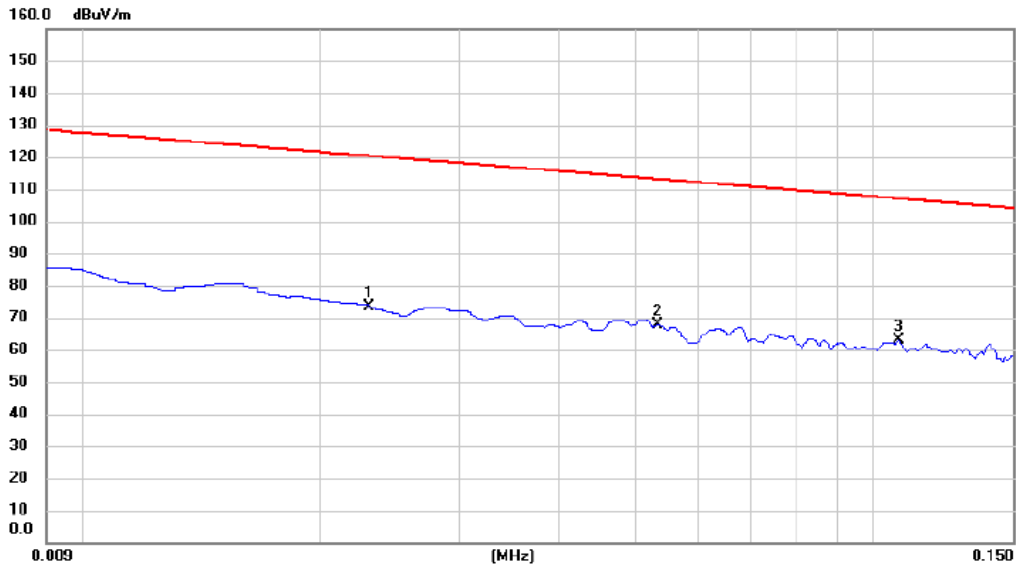

No.	Mk.	Freq. MHz	Reading Level dBuV	Correct Factor dB	Measure- ment dBuV/m	Limit dBuV/m	Margin dB	Detector	Comment
1		0.0230	53.26	20.18	73.44	120.40	-46.96	peak	
2		0.0534	47.96	19.81	67.77	113.13	-45.36	peak	
3	*	0.1076	43.07	19.83	62.90	107.08	-44.18	peak	

REMARKS:

- (1) Measurement Value = Reading Level + Correct Factor.
- (2) Margin Level = Measurement Value - Limit Value.

Test Mode	TX Mode_ 13.56MHz	Polarization	Ant 0°
-----------	-------------------	--------------	--------

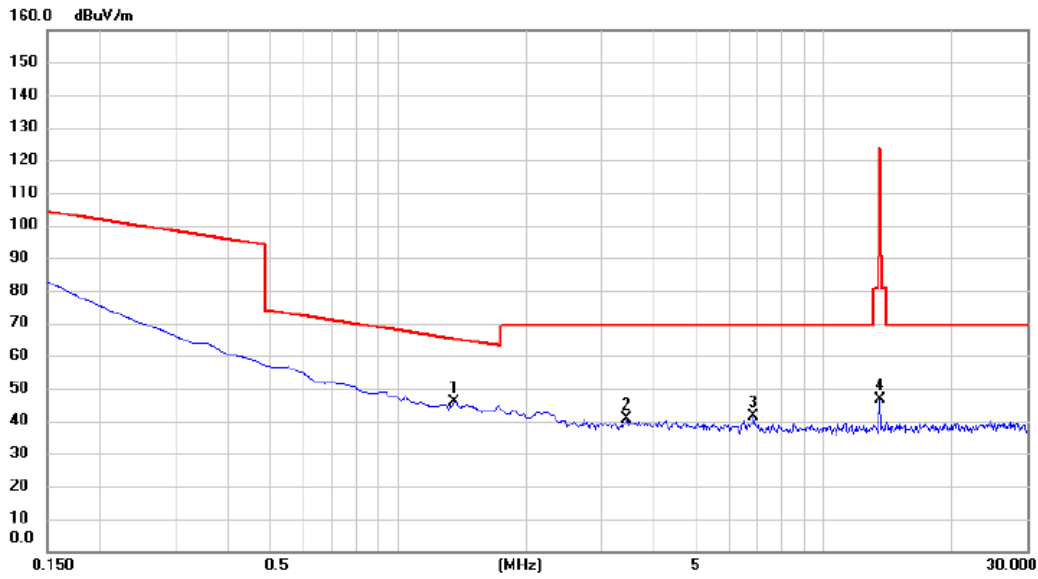

No.	Mk.	Freq. MHz	Reading Level dBuV	Correct Factor dB	Measure- ment dBuV/m	Limit dBuV/m	Margin dB	Detector	Comment
1	*	1.3590	26.08	19.84	45.92	65.19	-19.27	peak	
2		3.4483	20.81	19.89	40.70	69.50	-28.80	peak	
3		6.8064	21.31	20.01	41.32	69.50	-28.18	peak	
4		13.5675	26.24	20.25	46.49	90.50	-44.01	peak	

REMARKS:

- (1) Measurement Value = Reading Level + Correct Factor.
- (2) Margin Level = Measurement Value - Limit Value.

Test Mode	TX Mode_ 13.56MHz	Polarization	Ant 90°
-----------	-------------------	--------------	---------

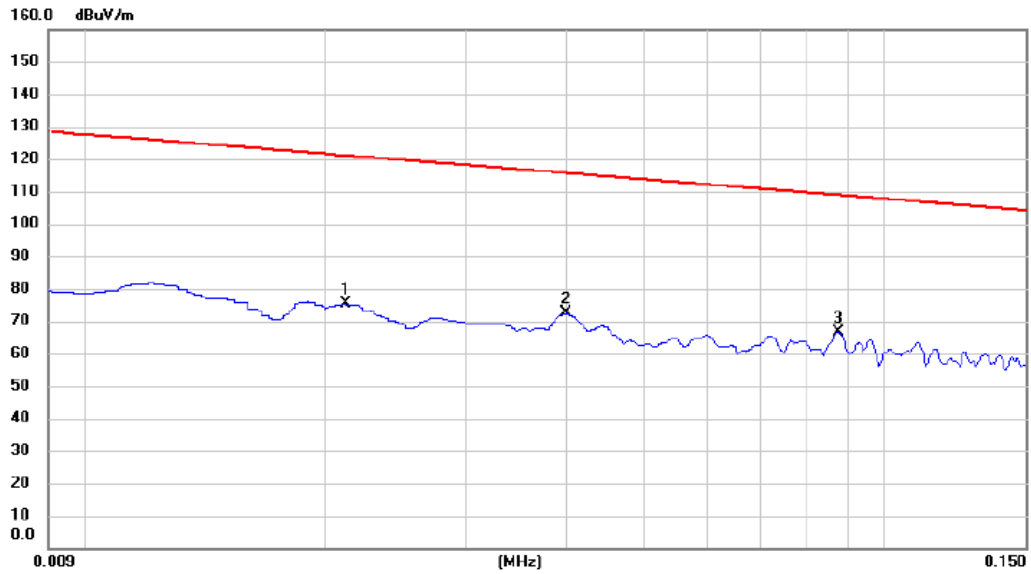

No.	Mk.	Freq. MHz	Reading Level dBuV	Correct Factor dB	Measure- ment dBuV/m	Limit dBuV/m	Margin dB	Detector	Comment
1		0.0212	54.95	20.28	75.23	121.11	-45.88	peak	
2		0.0400	52.62	19.80	72.42	115.63	-43.21	peak	
3	*	0.0874	46.64	19.86	66.50	108.88	-42.38	peak	

REMARKS:

- (1) Measurement Value = Reading Level + Correct Factor.
- (2) Margin Level = Measurement Value - Limit Value.

Test Mode	TX Mode_ 13.56MHz	Polarization	Ant 90°
-----------	-------------------	--------------	---------

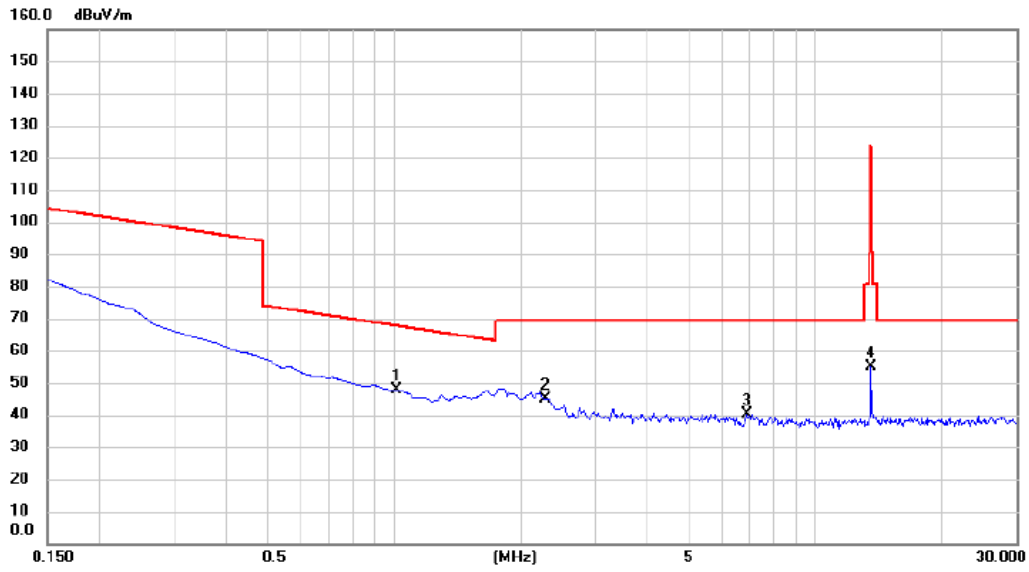

No.	Mk.	Freq.	Reading Level	Correct Factor	Measurement	Limit	Margin	Detector	Comment
		MHz	dBuV	dB	dBuV/m	dBuV/m	dB		
1	*	1.0156	27.92	19.87	47.79	67.70	-19.91	peak	
2		2.2845	25.22	19.81	45.03	69.50	-24.47	peak	
3		6.8960	20.36	20.01	40.37	69.50	-29.13	peak	
4		13.5525	34.83	20.25	55.08	90.50	-35.42	peak	

REMARKS:

- (1) Measurement Value = Reading Level + Correct Factor.
- (2) Margin Level = Measurement Value - Limit Value.

APPENDIX C - RADIATED EMISSION - 30 MHZ TO 1000 MHZ

Test Mode	TX Mode_ 13.56MHz	Polarization	Vertical
-----------	-------------------	--------------	----------

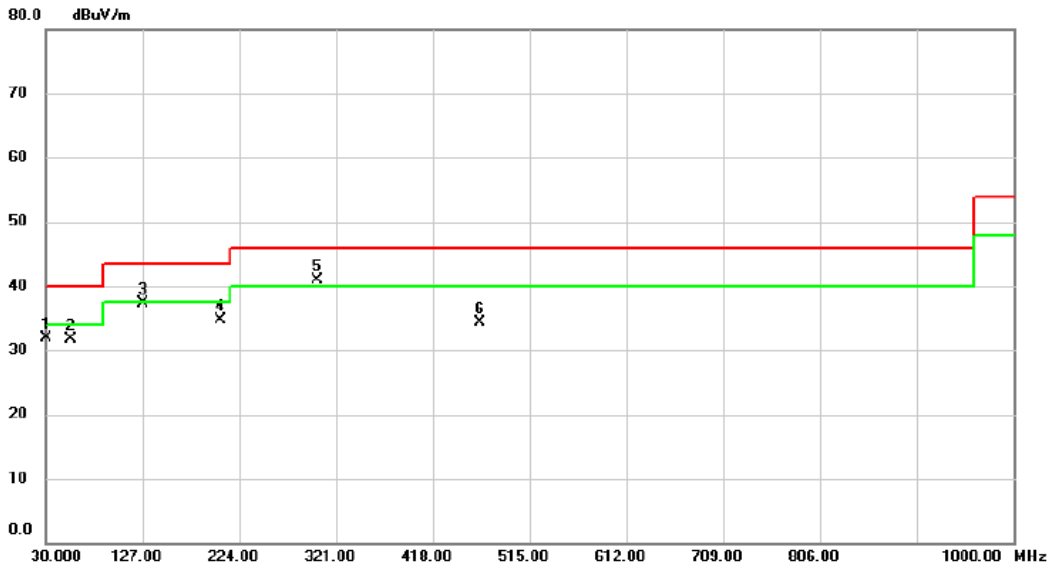

No. Mk.	Freq. MHz	Reading Level dBuV	Correct Factor dB	Measurement dBuV/m	Limit dBuV/m	Margin dB	Detector	Comment
1	30.0000	44.85	-12.95	31.90	40.00	-8.10	peak	
2	55.7050	43.31	-11.51	31.80	40.00	-8.20	peak	
3	127.9700	49.89	-12.64	37.25	43.50	-6.25	peak	
4	205.5700	48.92	-14.22	34.70	43.50	-8.80	peak	
5 *	302.0850	51.42	-10.57	40.85	46.00	-5.15	peak	
6	464.5600	40.79	-6.54	34.25	46.00	-11.75	peak	

REMARKS:

- (1) Measurement Value = Reading Level + Correct Factor.
- (2) Margin Level = Measurement Value - Limit Value.

Test Mode	TX Mode_ 13.56MHz	Polarization	Horizontal
-----------	-------------------	--------------	------------

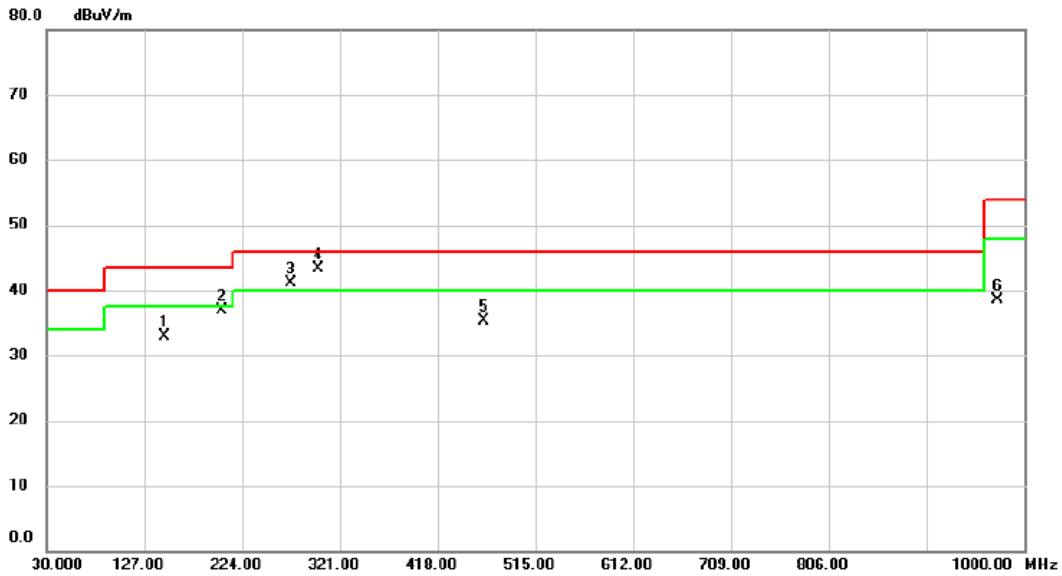

No.	Mk.	Freq. MHz	Reading Level dBuV	Correct Factor dB	Measure- ment dBuV/m	Limit dBuV/m	Margin dB	Detector	Comment
1		146.8850	44.29	-11.30	32.99	43.50	-10.51	peak	
2		204.1150	51.15	-14.22	36.93	43.50	-6.57	peak	
3	!	272.5000	52.47	-11.28	41.19	46.00	-4.81	peak	
4	*	299.1750	53.93	-10.67	43.26	46.00	-2.74	peak	
5		463.5900	41.94	-6.57	35.37	46.00	-10.63	peak	
6		973.3250	37.79	0.65	38.44	54.00	-15.56	peak	

REMARKS:

- (1) Measurement Value = Reading Level + Correct Factor.
- (2) Margin Level = Measurement Value - Limit Value.

APPENDIX D - FREQUENCY TOLERANCE

Test Mode	TX Mode_ 13.56MHz
-----------	-------------------

Frequency Tolerance Versus Environmental Temperature						
	Temperature (°C)	Voltage (V)	Frequency (MHz)	Frequency Error (kHz)	Limit (kHz)	Result
	20	120	13.5602	0.2	-	-
0 min	50	120	13.5602	0.2	+/- 1.356	PASS
	-20	120	13.5602	0.2	+/- 1.356	PASS
2 min	50	120	13.5602	0.2	+/- 1.356	PASS
	-20	120	13.5602	0.2	+/- 1.356	PASS
5 min	50	120	13.5602	0.2	+/- 1.356	PASS
	-20	120	13.5602	0.2	+/- 1.356	PASS
10 min	50	120	13.5602	0.2	+/- 1.356	PASS
	-20	120	13.5602	0.2	+/- 1.356	PASS

Frequency Tolerance Versus Input Voltage						
Temperature (°C)	Voltage (V)		Frequency (MHz)	Frequency Error (kHz)	Limit (kHz)	Result
20	V _{nom}	120	13.5602	0.2	-	-
20	V _{min}	102	13.5602	0.2	+/- 1.356	PASS
20	V _{max}	138	13.5602	0.2	+/- 1.356	PASS

APPENDIX E - BANDWIDTH

Test Mode	TX Mode_ 13.56MHz
-----------	-------------------

Frequency (MHz)	20 dB Bandwidth (MHz)	Result
13.56	0.0264	Complies

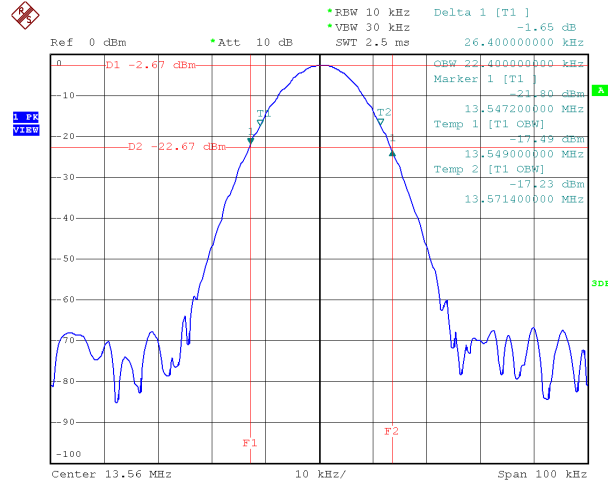

Date: 4.JAN.2024 18:15:28

End of Test Report