

8 7 6 5 4 3 2 1

REVISIONS				
ZONE	REV.	DESCRIPTION	DATE	APPROVED
	01	First Release	12/28/2016	
	02	Added FCC Label	3/23/2017	
	03	Sheet Metal changed for DB15 Clearance	7/24/2017	
	A	Production Release	7/27/2017	
	B	Changed Label PC DATA to XCVR SERIAL Added FCC Part 15 Statement	8/10/2017	

D

D

C

C

B

B

A

A

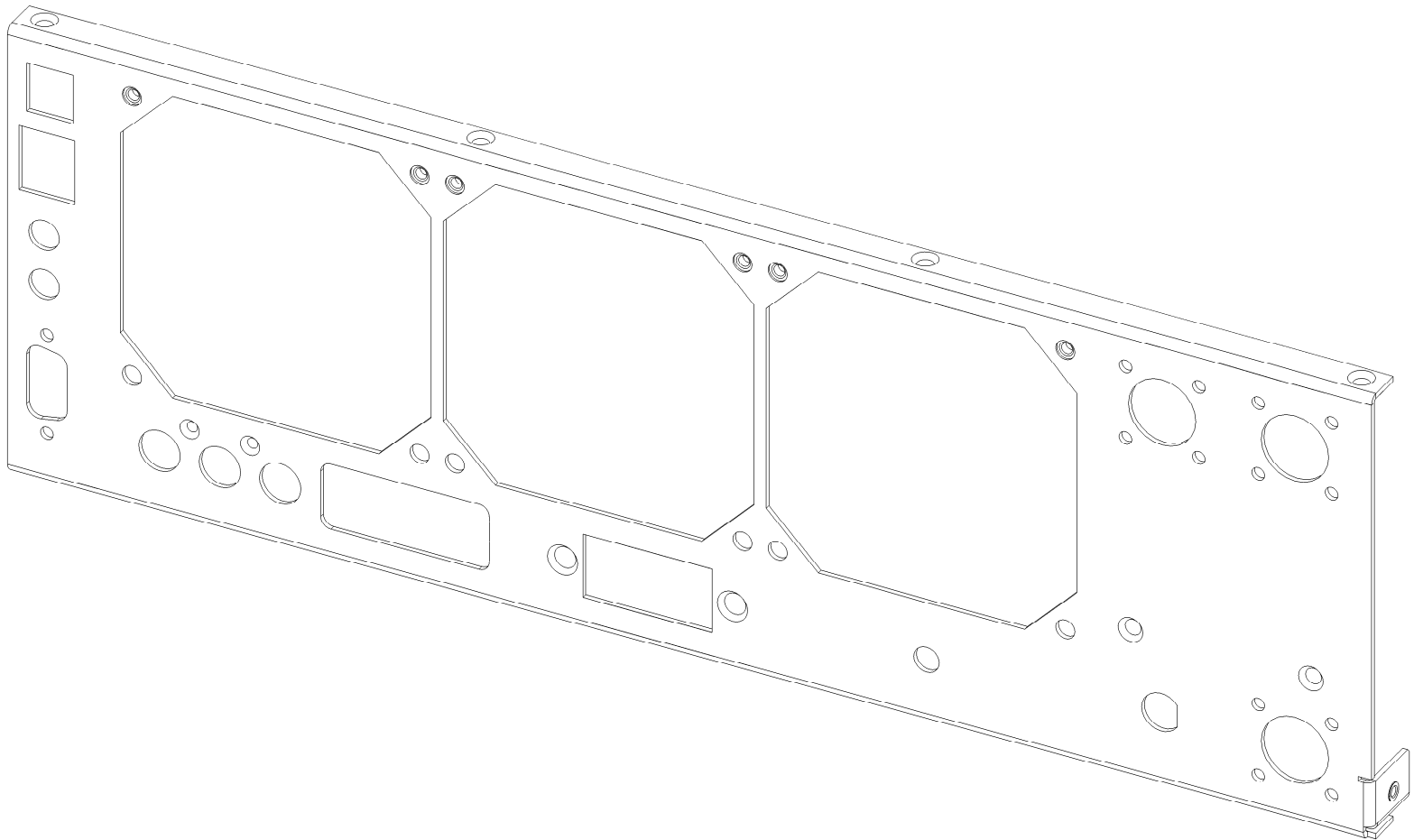

PROPRIETARY AND CONFIDENTIAL
 THE INFORMATION CONTAINED IN THIS DRAWING IS THE SOLE PROPERTY OF ELECRAFT INC. ANY REPRODUCTION IN PART OR AS A WHOLE WITHOUT THE WRITTEN PERMISSION OF ELECRAFT INC IS PROHIBITED.

		UNLESS OTHERWISE SPECIFIED:		NAME	DATE
		DIMENSIONS ARE IN INCHES	DRAWN	ACS	8/10/2017
		TOLERANCES:	CHECKED	RPW	8/10/2017
		FRACTIONAL ±	ENG APPR.	WAB	-
		ANGULAR: MACH ±.5 BEND ±	MFG APPR.	PDG	8/10/2017
		TWO PLACE DECIMAL ±0.02	Q.A.	CRS	-
		THREE PLACE DECIMAL ±0.01	COMMENTS:		
		INTERPRET GEOMETRIC TOLERANCING PER:			
		MATERIAL			
		FINISH			
NEXT ASSY	USED ON				
APPLICATION	DO NOT SCALE DRAWING				



TITLE: **KPA1500 Rear SilkScreen**

SIZE **B** DWG. NO. **E830040** REV **B**

SCALE: 1:1.5 WEIGHT: 0.18 SHEET 1 OF 2

8 7 6 5 4 3 2 1

8 7 6 5 4 3 2 1

D

D

C

C

B

B

A

A

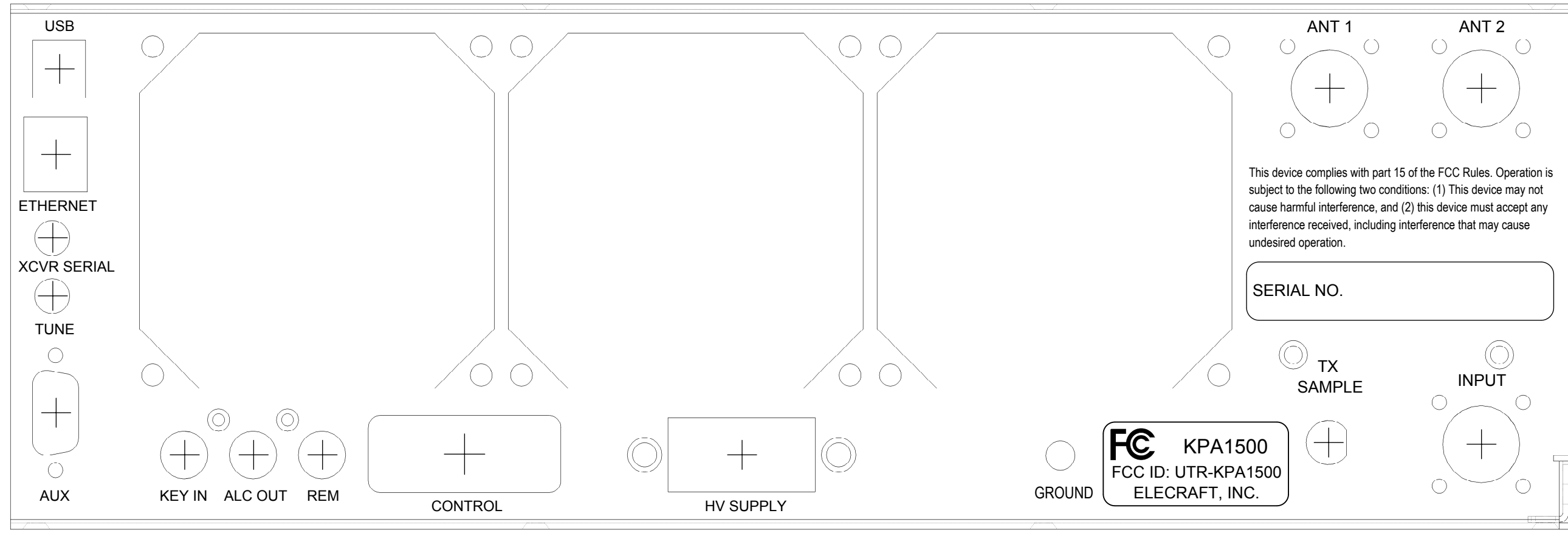

Notes:

1. Silkscreen color - WHITE
2. FCC Label Added - for Rev02
3. DB15 Cutout added for control signals

PROPRIETARY AND CONFIDENTIAL
 THE INFORMATION CONTAINED IN THIS DRAWING IS THE SOLE PROPERTY OF ELECRAFT INC. ANY REPRODUCTION IN PART OR AS A WHOLE WITHOUT THE WRITTEN PERMISSION OF ELECRAFT INC IS PROHIBITED.

		UNLESS OTHERWISE SPECIFIED:		NAME	DATE
		DIMENSIONS ARE IN INCHES		DRAWN	ACS 8/10/2017
		TOLERANCES:		CHECKED	RPW 8/10/2017
		FRACTIONAL ±		ENG APPR.	WAB -
		ANGULAR: MACH ±.5 BEND ±		MFG APPR.	PDG 8/10/2017
		TWO PLACE DECIMAL ±0.02		Q.A.	CRS -
		THREE PLACE DECIMAL ±0.01		COMMENTS:	
		INTERPRET GEOMETRIC TOLERANCING PER:			
		MATERIAL			
NEXT ASSY	USED ON	FINISH			
APPLICATION		DO NOT SCALE DRAWING			

ELECRAFT		
TITLE: KPA1500 Rear SilkScreen		
SIZE	DWG. NO.	REV
B	E830040	B
SCALE: 1:1	WEIGHT: 0.18	SHEET 2 OF 2

8 7 6 5 4 3 2 1