

- Area is applied by final assembly line
- Area is applied after mode typification

2:1

**Production Code (ZAYWW Dhhmm):**

	Meaning	Example
Z	Final Assembly Line Identification	A = EM D20 B = EM D40 C = EM D20-2
A	Initial Version of D501/D601	
Y	Year (last digit)	6 = 2016
WW	Calendar week	
D	Day of week	1 = Monday, 7 = Sunday
hh	Hours	24h mode
mm	Minutes	

**Mode Indication:**

X	Meaning
1	clean
2	clean, soft
3	clean, soft, polish
4	clean, soft, polish, massage
5	clean, pro clean, soft, polish, massage

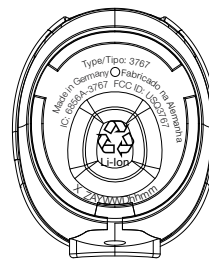
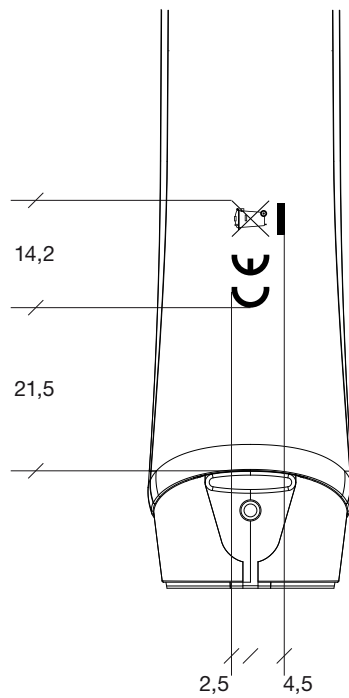

<b>RESTRICTED</b>	Project: <b>D601</b>		No: <b>90968274</b>				Sheet: <b>1 of 1</b>
	Article: <b>D601 Type Plate MN/NA</b>						Scale: <b>1 : 1</b>
							Tolerance: <b>± 0,3</b>
	Process: <b>Housing: Mold Marking</b>						Risk Classification: <b>n/a</b>
	Process: <b>Bottom: Laser Marking</b>						<b>BRAUN</b>
	Drawn	01.11.2016	Gasseling	00	HZ	01.11.2016	
Released			Index	Remarks	Date	Name	