

FCC and ISED Test Report

Paxton Access Ltd
Net2 Proximity Mifare Reader, Model: P50 (RFiD)

In accordance with FCC 47 CFR Part 15B,
ICES-003 and ISED RSS-GEN

Prepared for: Paxton Access Ltd
Paxton House
Home Farm Road
Brighton
BN1 9HU
United Kingdom



Add value.
Inspire trust.

FCC ID: USE353467 IC: 10217A-353467

COMMERCIAL-IN-CONFIDENCE

Document 75948439-01 Issue 01

SIGNATURE

NAME	JOB TITLE	RESPONSIBLE FOR	ISSUE DATE
Andy Lawson	Senior Engineer	Authorised Signatory	10 November 2020

Signatures in this approval box have checked this document in line with the requirements of TÜV SÜD document control rules.

ENGINEERING STATEMENT

The measurements shown in this report were made in accordance with the procedures described on test pages. All reported testing was carried out on a sample equipment to demonstrate limited compliance FCC 47 CFR Part 15B, ICES-003 and ISED RSS-GEN. The sample tested was found to comply with the requirements defined in the applied rules.

RESPONSIBLE FOR	NAME	DATE	SIGNATURE
Testing	Liang Tian	10 November 2020	

FCC Accreditation

90987 Octagon House, Fareham Test Laboratory

ISED Accreditation

12669A Octagon House, Fareham Test Laboratory

EXECUTIVE SUMMARY

A sample of this product was tested and found to be compliant with FCC 47 CFR Part 15B: 2019, ICES-003: 2016 and ISED RSS-GEN: Issue 5 and A1 (2019-03) for the tests detailed in section 1.3.



DISCLAIMER AND COPYRIGHT

This non-binding report has been prepared by TÜV SÜD with all reasonable skill and care. The document is confidential to the potential Client and TÜV SÜD. No part of this document may be reproduced without the prior written approval of TÜV SÜD. © 2020 TÜV SÜD. This report relates only to the actual item/items tested.

ACCREDITATION

Our UKAS Accreditation does not cover opinions and interpretations and any expressed are outside the scope of our UKAS Accreditation. Results of tests not covered by our UKAS Accreditation Schedule are marked NUA (Not UKAS Accredited).

TÜV SÜD
is a trading name of TÜV SÜD Ltd
Registered in Scotland at East Kilbride,
Glasgow G75 0QF, United Kingdom
Registered number: SC215164

TÜV SÜD Ltd is a
TÜV SÜD Group Company

Phone: +44 (0) 1489 558100
Fax: +44 (0) 1489 558101
www.tuv-sud.co.uk

TÜV SÜD
Octagon House
Concorde Way
Fareham
Hampshire PO15 5RL
United Kingdom



Contents

1	Report Summary	2
1.1	Report Modification Record.....	2
1.2	Introduction.....	2
1.3	Brief Summary of Results	3
1.4	Customer Supplied Form	4
1.5	Product Information	6
1.6	Deviations from the Standard.....	6
1.7	EUT Modification Record	6
1.8	Test Location	6
2	Test Details	7
2.1	Radiated Disturbance.....	7
3	Incident Reports	13
4	Measurement Uncertainty	14



1 Report Summary

1.1 Report Modification Record

Alterations and additions to this report will be issued to the holders of each copy in the form of a complete document.

Issue	Description of Change	Date of Issue
1	First Issue	10 November 2020

Table 1

1.2 Introduction

Applicant	Paxton Access Ltd
Manufacturer	Paxton Access Ltd
Model Number(s)	P50
Serial Number(s)	6767123
Hardware Version(s)	z-df53_Rev 3
Software Version(s)	V1.11
Number of Samples Tested	1
Test Specification/Issue/Date	FCC 47 CFR Part 15B: 2019 ICES-003: 2016 ISED RSS-GEN: Issue 5 and A1 (2019-03)
Order Number	193063
Date	24-February-2020
Date of Receipt of EUT	17-April-2020
Start of Test	28-September-2020
Finish of Test	28-September-2020
Name of Engineer(s)	Liang Tian
Related Document(s)	ANSI C63.4: 2014



1.3 Brief Summary of Results

A brief summary of the tests carried out in accordance with FCC 47 CFR Part 15B, ICES-003 and ISED RSS-GEN is shown below.

Section	Specification Clause			Test Description	Result	Comments/Base Standard
	Part 15B	ICES-003	RSS-GEN			
Configuration and Mode: DC Powered - Idle						
2.1	15.109	6.2	7.1	Radiated Disturbance	Pass	ANSI C63.4: 2014

Table 2



1.4 Customer Supplied Form

Equipment Description

Technical Description: <i>(Please provide a brief description of the intended use of the equipment)</i>	Net2 Proximity Mifare Reader for access control. It has dual frequency functionality for reading tokens with 125 kHz and 13.56 MHz carrier frequencies.
Manufacturer:	Paxton Access Ltd
Model:	P50
Part Number:	353-467
Hardware Version:	z-df53_Rev 3
Software Version:	V1.11
FCC ID (if applicable)	USE353467
IC ID (if applicable)	10217A-353467

Intentional Radiators

Technology	RFID	RFID
Frequency Band (MHz)	0.125	13.56
Conducted Declared Output Power (dBm)	-47	-44
Antenna Gain (dBi)	< 2	< 2
Supported Bandwidth(s) (MHz)	5 kHz	1.1 kHz
Modulation Scheme(s)	AM	AM
ITU Emission Designator	5K001D	5K331D
Bottom Frequency (MHz)	0.125	13.56
Middle Frequency (MHz)	0.125	13.56
Top Frequency (MHz)	0.125	13.56

Un-intentional Radiators

Highest frequency generated or used in the device or on which the device operates or tunes	27.12 MHz
Lowest frequency generated or used in the device or on which the device operates or tunes	125 kHz
Class A Digital Device (Use in commercial, industrial or business environment) <input type="checkbox"/>	
Class B Digital Device (Use in residential environment only) <input checked="" type="checkbox"/>	

AC Power Source

AC supply frequency:		Hz
Voltage		V
Max current:		A
Single Phase <input type="checkbox"/> Three Phase <input type="checkbox"/>		



DC Power Source

Nominal voltage:	13	V
Extreme upper voltage:	13.83	V
Extreme lower voltage:	12.61	V
Max current:	120	mA

Battery Power Source

Voltage:		V
End-point voltage:		V (Point at which the battery will terminate)
Alkaline <input type="checkbox"/> Leclanche <input type="checkbox"/> Lithium <input type="checkbox"/> Nickel Cadmium <input type="checkbox"/> Lead Acid* <input type="checkbox"/> *(Vehicle regulated)		
Other <input type="checkbox"/>	Please detail:	

Charging

Can the EUT transmit whilst being charged	Yes <input type="checkbox"/> No <input checked="" type="checkbox"/>
---	---

Temperature

Minimum temperature:	-20.0	°C
Maximum temperature:	+55.0	°C

Antenna Characteristics

Antenna connector <input type="checkbox"/>	State impedance		Ohm
Temporary antenna connector <input type="checkbox"/>	State impedance		Ohm
Integral antenna <input checked="" type="checkbox"/>	Type: PCB Antenna & Coil Antenna	Gain	< 2 dBi
External antenna <input type="checkbox"/>	Type:	Gain	dBi
For external antenna only: Standard Antenna Jack <input type="checkbox"/> If yes, describe how user is prohibited from changing antenna (if not professional installed): Equipment is only ever professionally installed <input type="checkbox"/> Non-standard Antenna Jack <input type="checkbox"/>			

Ancillaries (if applicable)

Manufacturer:		Part Number:	
Model:		Country of Origin:	

I hereby declare that the information supplied is correct and complete.

Name: Kevin Feeney
 Position held: Compliance Engineer
 Date: 20.03.2020



1.5 Product Information

1.5.1 Technical Description

The equipment under test (EUT) was a Net2 Proximity Mifare Reader, used for access control.

It has dual frequency functionality for reading tokens with 125 kHz and 13.56 MHz carrier frequencies.

1.5.2 Test Configuration

Configuration	Description
DC Powered	The EUT was powered by a 12 V DC supply from the control panel which was powered by 117 V 60 Hz AC.

Table 3

1.5.3 Mode(s) of Operation

Mode	Description
Idle	The EUT was operating in a mode in which it has the capability to transmit, however no commands were sent to the EUT to ensure the device was operating in an idle state.

Table 4

1.6 Deviations from the Standard

No deviations from the applicable test standard were made during testing.

1.7 EUT Modification Record

The table below details modifications made to the EUT during the test programme.

The modifications incorporated during each test are recorded on the appropriate test pages.

Modification State	Description of Modification still fitted to EUT	Modification Fitted By	Date Modification Fitted
Net2 Proximity Mifare Reader, Model: P50, Serial Number: 6767123			
0	As supplied by the customer	Not Applicable	Not Applicable

Table 5

1.8 Test Location

TÜV SÜD conducted the following tests at our Fareham Test Laboratory.

Test Name	Name of Engineer(s)	Accreditation
Configuration and Mode: DC Powered - Idle		
Radiated Disturbance	Liang Tian	UKAS

Table 6

Office Address:

Octagon House, Concorde Way,
Segensworth North, Fareham, Hampshire,
PO15 5RL, United Kingdom



2 Test Details

2.1 Radiated Disturbance

2.1.1 Specification Reference

FCC 47 CFR Part 15B, Clause 15.109
ICES-003, Clause 6.2
ISED RSS-GEN, Clause 7.1

2.1.2 Equipment Under Test and Modification State

P50, S/N: 6767123 - Modification State 0

2.1.3 Date of Test

28-September-2020

2.1.4 Test Method

The EUT was set up on a non-conductive table 0.8 m above a reference ground plane within a semi-anechoic chamber on a remotely controlled turntable.

A pre-scan of the EUT emissions profile using a peak detector was made at a 3 m antenna distance whilst varying the antenna-to-EUT azimuth and polarisation.

For an EUT which could reasonable be used in multiple planes, pre-scans were performed with the EUT orientated in X, Y and Z planes with reference to the ground plane.

Using a list of the highest emissions detected during the pre-scan along with their bearing and associated antenna polarisation, the EUT was then formally measured using a Quasi-Peak, Peak or CISPR Average detector as appropriate.

The readings were maximised by adjusting the antenna height, polarisation and turntable azimuth, in accordance with the specification.

2.1.5 Example Calculation

Below 1 GHz:

$$\begin{aligned} \text{Quasi-Peak level (dB}\mu\text{V/m)} &= \text{Receiver level (dB}\mu\text{V)} + \text{Correction Factor (dB/m)} \\ \text{Margin (dB)} &= \text{Quasi-Peak level (dB}\mu\text{V/m)} - \text{Limit (dB}\mu\text{V/m)} \end{aligned}$$

Above 1 GHz:

$$\begin{aligned} \text{CISPR Average level (dB}\mu\text{V/m)} &= \text{Receiver level (dB}\mu\text{V)} + \text{Correction Factor (dB/m)} \\ \text{Margin (dB)} &= \text{CISPR Average level (dB}\mu\text{V/m)} - \text{Limit (dB}\mu\text{V/m)} \end{aligned}$$

$$\begin{aligned} \text{Peak level (dB}\mu\text{V/m)} &= \text{Receiver level (dB}\mu\text{V)} + \text{Correction Factor (dB/m)} \\ \text{Margin (dB)} &= \text{Peak level (dB}\mu\text{V/m)} - \text{Limit (dB}\mu\text{V/m)} \end{aligned}$$

2.1.6 Example Test Setup Diagram

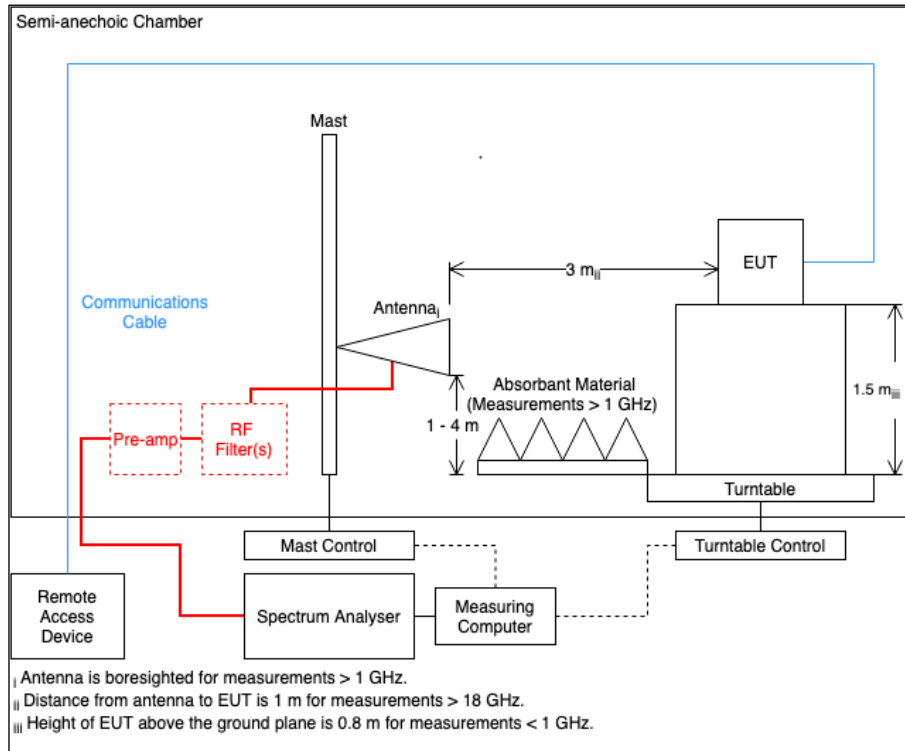

Figure 1

2.1.7 Environmental Conditions

Ambient Temperature 20.9 °C
 Relative Humidity 46.0 %

2.1.8 Specification Limits

Required Specification Limits, Field Strength - Class B Test Limit at a 3 m Measurement Distance		
Frequency Range (MHz)	Test Limit (µV/m)	Test Limit (dBµV/m)
30 to 88	100	40.0
88 to 216	150	43.5
216 to 960	200	46.0
Above 960	500	54.0

Supplementary information:
 Note 1. A Quasi-peak detector is to be used for measurements below 1 GHz.
 Note 2. A CISPR Average detector is to be used for measurements above 1 GHz.
 Note 3. The Peak test limit above 1 GHz is 20 dB higher than the CISPR Average test limit.

Table 7



2.1.9 Test Results

Results for Configuration and Mode: DC Powered - Idle.

This test was performed to the requirements of the Class B limits.

Performance assessment of the EUT made during this test: Pass.

Detailed results are shown below.

Highest frequency generated or used within the EUT: 27.12 MHz
 Which necessitates an upper frequency test limit of: 1 GHz

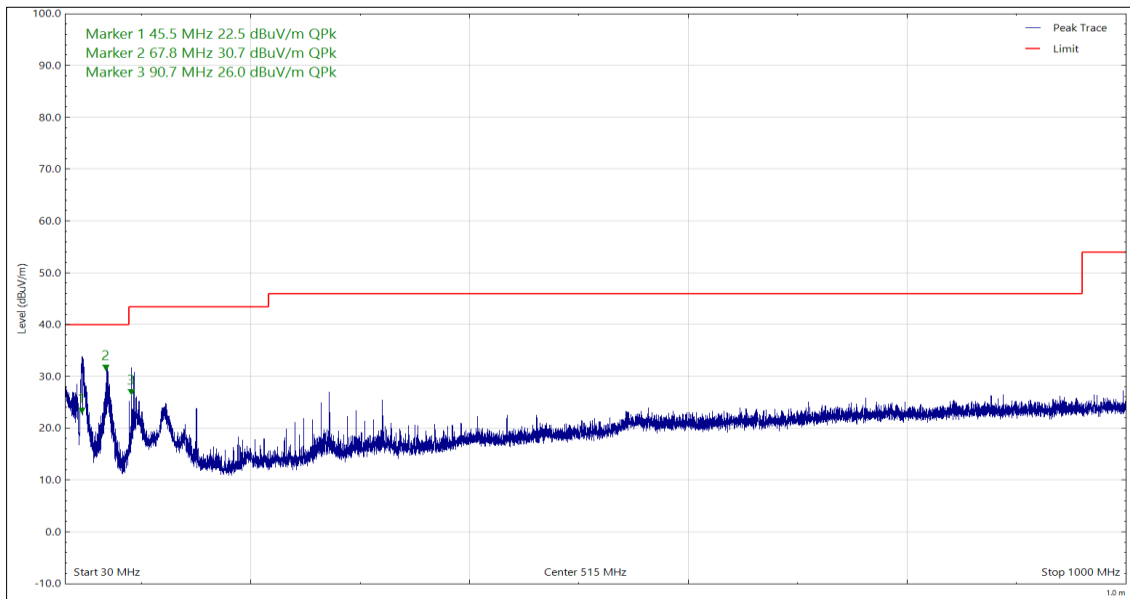

Figure 2 - 30 MHz to 1 GHz, Quasi-Peak, Vertical

Frequency (MHz)	Level (dBuV/m)	Limit (dBuV/m)	Margin (dB)	Detector	Angle (°)	Height (cm)	Polarisation
45.512	22.5	40.0	-17.5	Q-Peak	356	238	Vertical
67.815	30.7	40.0	-9.3	Q-Peak	44	100	Vertical
90.702	26.0	43.5	17.5	Q-Peak	307	100	Vertical

Table 8

No other final measurements were made as all other peak emissions seen above the measurement system noise floor during the pre-scan were greater than 10 dB below the test limit.

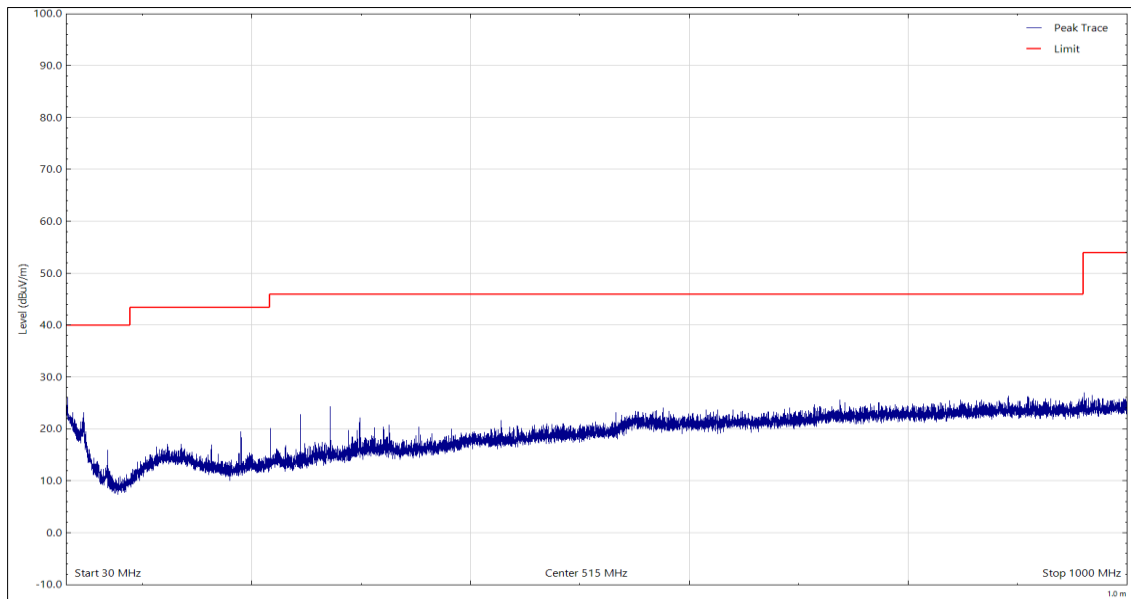

Figure 3 - 30 MHz to 1 GHz, Quasi-Peak, Horizontal

Frequency (MHz)	Level (dBuV/m)	Limit (dBuV/m)	Margin (dB)	Detector	Angle (°)	Height (cm)	Polarisation
*							

Table 9

*No final measurements were made as all peak emissions seen above the measurement system noise floor during the pre-scan were greater than 10 dB below the test limit.



Figure 4 - Test Setup - 30 MHz to 1 GHz



2.1.10 Test Location and Test Equipment Used

This test was carried out in EMC Chamber 5.

Instrument	Manufacturer	Type No	TE No	Calibration Period (months)	Calibration Due
Screened Room (5)	Rainford	Rainford	1545	36	23-Jan-2021
EmX Emissions Software	TUV SUD	V1.6.3	5125	-	Software
Turntable Controller	Inn-Co GmbH	CO 1000	1606	-	TU
Mast Controller	Maturo GmbH	NCD	4810	-	TU
Tilt Antenna Mast	Maturo GmbH	TAM 4.0-P	4811	-	TU
2m SMA Cable	Junkosha	MWX221-02000AMSAMS/A	5517	12	01-Apr-2021
8m N-Type Cable	Junkosha	MWX221-08000NMSNMS/B	5520	12	24-Mar-2021
EMI Test Receiver	Rohde & Schwarz	ESW44	5527	12	06-Feb-2021
Antenna with permanent attenuator (Bilog)	Chase	CBL6143	2904	24	30-Sep-2021

Table 10

TU – Traceability Unscheduled



3 Incident Reports

No incidents reports were raised.



4 Measurement Uncertainty

For a 95% confidence level, the measurement uncertainties for defined systems are:

Test Name	Measurement Uncertainty
Radiated Disturbance	30 MHz to 1 GHz, Bilog Antenna, ± 5.2 dB 1 GHz to 40 GHz, Horn Antenna, ± 6.3 dB

Table 11

Worst case error for both Time and Frequency measurement 12 parts in 10^6 .

Measurement Uncertainty Decision Rule

Determination of conformity with the specification limits is based on the decision rule according to IEC Guide 115: 2007, clause 4.4.3 and 4.5.1.