



TEST REPORT

Test Report No. : UL-RPT-RP11888510-616A

Manufacturer : Paxton Access Ltd
Model Name / PMN : Paxton10 Reader Keypad
HVIN : 010-721
FCC ID : USE010721
IC Certification No. : IC: 10217A-010721
Technology : RFID – 13.56 MHz
Test Standard(s) : FCC Parts 15.207, 15.209(a) & 15.225;
ISED Canada RSS-Gen Issue 4 November 2014 Sections 6.6, 6.11,
6.12, 6.13 & 8.8, RSS-210 Issue 9 August 2016 Section B.6

1. This test report shall not be reproduced in full or partial, without the written approval of UL VS LTD.
2. The results in this report apply only to the sample(s) tested.
3. The sample tested is in compliance with the above standard(s).
4. The test results in this report are traceable to the national or international standards.
5. Version 1.0.

Date of Issue: 19 January 2018

Checked by:

Ian Watch
Senior Engineer, Radio Laboratory

Company Signatory:

Sarah Williams
Senior Engineer, Radio Laboratory



This laboratory is accredited by UKAS.
The tests reported herein have been
performed in accordance with its terms
of accreditation.

UL VS LTD

Pavilion A, Ashwood Park, Ashwood Way, Basingstoke, Hampshire, RG23 8BG, UK
Telephone: +44 (0)1256 312000
Facsimile: +44 (0)1256 312001

This page has been left intentionally blank.

Table of Contents

1. Customer Information.....	4
2. Summary of Testing.....	5
2.1. General Information	5
2.2. Summary of Test Results	5
2.3. Methods and Procedures	6
2.4. Deviations from the Test Specification	6
3. Equipment Under Test (EUT)	7
3.1. Identification of Equipment Under Test (EUT)	7
3.2. Description of EUT	7
3.3. Modifications Incorporated in the EUT	7
3.4. Additional Information Related to Testing	8
3.5. Support Equipment	9
4. Operation and Monitoring of the EUT during Testing	10
4.1. Operating Modes	10
4.2. Configuration and Peripherals	10
5. Measurements, Examinations and Derived Results	11
5.1. General Comments	11
5.2. Test Results	12
5.2.1. Transmitter AC Conducted Spurious Emissions	12
5.2.2. Transmitter Fundamental Field Strength	18
5.2.3. Transmitter Radiated Spurious Emissions	24
5.2.4. Transmitter Band Edge Radiated Emissions	33
5.2.5. Transmitter 99% Emission Bandwidth	35
5.2.6. Transmitter Frequency Stability (Temperature & Voltage Variation)	37
6. Measurement Uncertainty	40
7. Report Revision History	41
8. Appendix 1	42

1. Customer Information









Company Name:	Paxton Access Ltd
Address:	Paxton House Home Farm Brighton Sussex BN1 9HU United Kingdom

2. Summary of Testing

2.1. General Information

Specification Reference:	47CFR15.225
Specification Title:	Code of Federal Regulations Volume 47 (Telecommunications): Part 15 Subpart C (Radio Frequency Devices) - Section 15.225
Specification Reference:	47CFR15.207 and 47CFR15.209
Specification Title:	Code of Federal Regulations Volume 47 (Telecommunications): Part 15 Subpart C (Intentional Radiators) - Sections 15.207 and 15.209
Specification Reference:	RSS-Gen Issue 4 November 2014
Specification Title:	General Requirements for Compliance of Radio Apparatus
Specification Reference:	RSS-210 Issue 9 August 2016
Specification Title:	Licence-exempt Radio Apparatus: Category I Equipment.
Site Registration:	FCC: 209735; ISED Canada: 3245B-2
Location of Testing:	UL VS LTD, Unit 3 Horizon, Wade Road, Kingsland Business Park, Basingstoke, Hampshire, RG24 8AH, United Kingdom
Test Dates:	20 December 2017 to 18 January 2018

2.2. Summary of Test Results

FCC Reference (47CFR)	ISED Canada Reference	Measurement	Result
Part 15.207	RSS-Gen 8.8	Transmitter AC Conducted Emissions	
Part 15.225(a)(b)(c)(d)	RSS-Gen 6.12 RSS-210 B.6	Transmitter Fundamental Field Strength	
Part 15.209(a)/ 15.225(d)	RSS-Gen 6.13 RSS-210 B.6	Transmitter Radiated Emissions	
Part 15.209(a)/ 15.225(c)(d)	RSS-Gen 6.13 RSS-210 B.6	Transmitter Band Edge Radiated Emissions	
N/A	RSS-Gen 6.6	Transmitter 99% Emission Bandwidth	
Part 15.225(e)	RSS-Gen 6.11 RSS-210 B.6	Transmitter Frequency Stability (Temperature & Voltage Variation)	
Key to Results			
 = Complied  = Did not comply			

2.3. Methods and Procedures

Reference:	ANSI C63.4-2014
Title:	American National Standard for Methods of Measurement of Radio-Noise Emissions from Low-Voltage Electrical and Electronic Equipment in the Range of 9 kHz to 40 GHz
Reference:	ANSI C63.10-2013
Title:	American National Standard of Procedures for Compliance Testing of Unlicensed Wireless Devices
Reference:	FCC KDB Publication Number 414788 D01 Date: 18 April 2017
Title:	TEST SITES FOR RADIATED EMISSION MEASUREMENTS
Reference:	FCC KDB 174176 D01 Line Conducted FAQ v01r01 June 3, 2015
Title:	AC Power-Line Conducted Emissions Frequently Asked Questions

2.4. Deviations from the Test Specification

For the measurements contained within this test report, there were no deviations from, additions to, or exclusions from the test specification identified above.

3. Equipment Under Test (EUT)

3.1. Identification of Equipment Under Test (EUT)

Brand Name:	Paxton10
Model Name / PMN:	Paxton10 Reader Keypad
HVIN:	010-721
Test Sample Serial Number:	Marked as '13.56 MHz Tx Mode Sample'
Hardware Version:	Rev D, z-n051k Rev 5, z-n053 Rev 3
Software Version:	2.07.6540.30069
FCC ID:	USE010721
ISED Canada Certification Number:	IC: 10217A-010721

3.2. Description of EUT

The Equipment Under Test was a keypad reader for a door entry system. It contains 125 kHz and 13.56 MHz transmitters. The antenna is integral.

3.3. Modifications Incorporated in the EUT

No modifications were applied to the EUT during testing.

3.4. Additional Information Related to Testing

Tested Technology:	RFID	
Category of Equipment:	Transceiver	
Channel Spacing:	Single channel device	
Transmit Frequency Range:	13.56 MHz	
Power Supply Requirement:	Nominal	120 VAC 60 Hz
	Minimum	102 VAC 60 Hz
	Maximum	138 VAC 60 Hz
Tested Temperature Range:	Minimum	-20 °C
	Maximum	55 °C

3.5. Support Equipment

The following support equipment was used to exercise the EUT during testing:

Description:	Paxton10
Brand Name:	Paxton10 controller
Model Name or Number:	010-121
Serial Number:	2934419
Hardware Version:	Rev C
Software Version:	2.07.6540.30069

Description:	Paxton10
Brand Name:	Paxton10 door connector
Model Name or Number:	010-519
Serial Number:	3652604
Hardware Version:	Rev C
Software Version:	Not marked or stated

Description:	PoE Injector
Brand Name:	Phihong
Model Name or Number:	POE-31U-1AT

Description:	Ethernet router
Brand Name:	TP Link
Model Name or Number:	TL-WR84XX

Description:	Ethernet cable. Length 0.5 metres
Brand Name:	Not marked or stated
Model Name or Number:	Not marked or stated

Description:	Ethernet cable. Length 1.0 metre. Quantity 2.
Brand Name:	Not marked or stated
Model Name or Number:	Not marked or stated

Description:	Laptop PC
Brand Name:	Dell
Model Name or Number:	Latitude D610

4. Operation and Monitoring of the EUT during Testing

4.1. Operating Modes

The EUT was tested in the following operating mode(s):

- Transmitting with a modulated carrier in RFID test mode.

4.2. Configuration and Peripherals

The EUT was tested in the following configuration(s):

- The EUT and support equipment was configured following customer's test mode instructions 'Paxton10 Keypad reader – test set-up for radio testing'.
- The EUT started transmitting as soon as it was connected to the Paxton10 Controller.
- The support equipment was placed in a screened box away from the EUT during final radiated emission measurements.
- The Paxton10 system was powered from a PoE injector connected to an AC mains supply during all tests.

5. Measurements, Examinations and Derived Results

5.1. General Comments

Measurement uncertainties are evaluated in accordance with current best practice. Our reported expanded uncertainties are based on standard uncertainties, which are multiplied by an appropriate coverage factor to provide a statistical confidence level of approximately 95%. Please refer to *Section 6: Measurement Uncertainties* for details.

In accordance with UKAS requirements all the measurement equipment is on a calibration schedule. All equipment was within the calibration period on the date of testing.

5.2. Test Results

5.2.1. Transmitter AC Conducted Spurious Emissions

Test Summary:

Test Engineers:	Ian Watch & Victor Carmon	Test Date:	13 January 2018
Test Sample Serial Numbers:	13.56 MHz Tx Mode Sample		

FCC Reference:	Part 15.207
ISED Canada Reference:	RSS-Gen 8.8
Test Method Used:	ANSI C63.10 Section 6.2 / FCC KDB 174176 and Notes below

Environmental Conditions:

Temperature (°C):	20 to 21
Relative Humidity (%):	36 to 39

Note(s):

1. The EUT was connected to a 120 VAC 60 Hz single phase supply single phase supply via a LISN.
2. A pulse limiter was fitted between the LISN and the test receiver.
3. Pre-scans were performed and markers placed on the highest live and neutral measured levels. Final measurements were performed on the marker frequencies and the results entered into the tables below.
4. In accordance with FCC KDB 174176 Q4, tests were also performed with a 240 VAC 60 Hz single phase supply as this was within the voltage range marked on the PoE supply for the Paxton10 system.

Transmitter AC Conducted Spurious Emissions (continued)

Test setup:

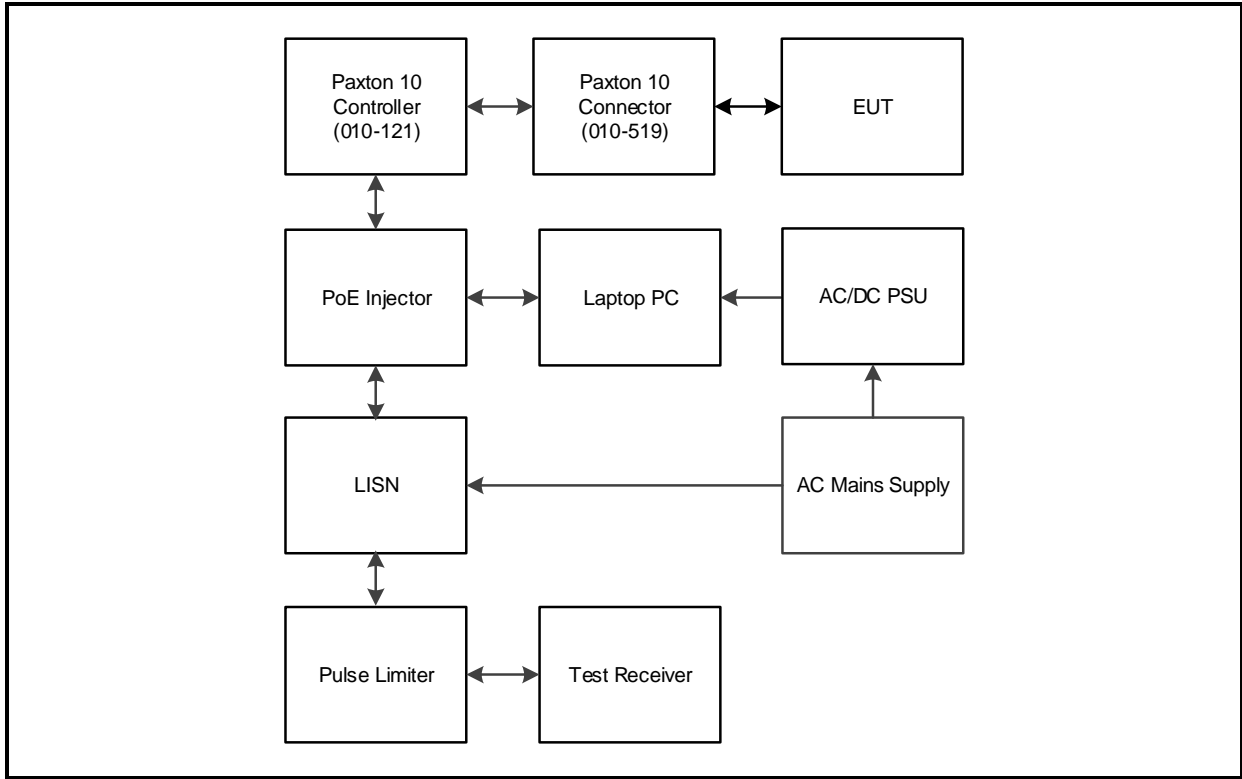

Transmitter AC Conducted Spurious Emissions (continued)**Results: Live / Quasi Peak / 120 VAC 60 Hz**

Frequency (MHz)	Line	Level (dB μ V)	Limit (dB μ V)	Margin (dB)	Result
0.172500	Live	47.6	64.8	17.2	Complied
0.226500	Live	40.3	62.6	22.3	Complied
0.667500	Live	34.4	56.0	21.6	Complied
3.079500	Live	37.7	56.0	18.3	Complied
13.560000	Live	48.3	60.0	11.7	Complied
22.096500	Live	41.2	60.0	18.8	Complied

Results: Live / Average / 120 VAC 60 Hz

Frequency (MHz)	Line	Level (dB μ V)	Limit (dB μ V)	Margin (dB)	Result
0.267000	Live	37.3	51.2	13.9	Complied
0.402000	Live	36.4	47.8	11.4	Complied
0.667500	Live	33.7	46.0	12.3	Complied
3.079500	Live	37.2	46.0	8.8	Complied
13.560000	Live	42.6	50.0	7.4	Complied
21.160500	Live	41.0	50.0	9.0	Complied

Results: Neutral / Quasi Peak / 120 VAC 60 Hz

Frequency (MHz)	Line	Level (dB μ V)	Limit (dB μ V)	Margin (dB)	Result
0.168000	Neutral	45.3	65.1	19.8	Complied
0.402000	Neutral	39.4	57.8	18.4	Complied
0.667500	Neutral	35.2	56.0	20.8	Complied
3.214500	Neutral	38.0	56.0	18.0	Complied
13.560000	Neutral	48.6	60.0	11.4	Complied
21.165000	Neutral	40.1	60.0	19.9	Complied

Results: Neutral / Average / 120 VAC 60 Hz

Frequency (MHz)	Line	Level (dB μ V)	Limit (dB μ V)	Margin (dB)	Result
0.267000	Neutral	37.1	51.2	14.1	Complied
0.402000	Neutral	36.4	47.8	11.4	Complied
0.667500	Neutral	33.7	46.0	12.3	Complied
3.214500	Neutral	37.4	46.0	8.6	Complied
13.555500	Neutral	37.4	50.0	12.6	Complied
21.165000	Neutral	40.1	50.0	9.9	Complied

Transmitter AC Conducted Spurious Emissions (continued)

Results: 120 VAC 60 Hz

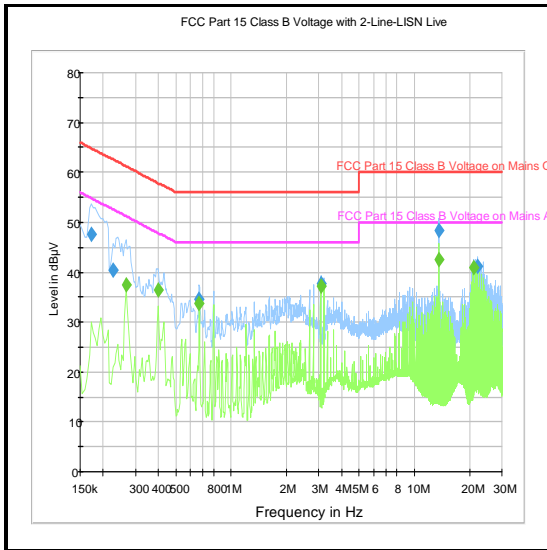

Live

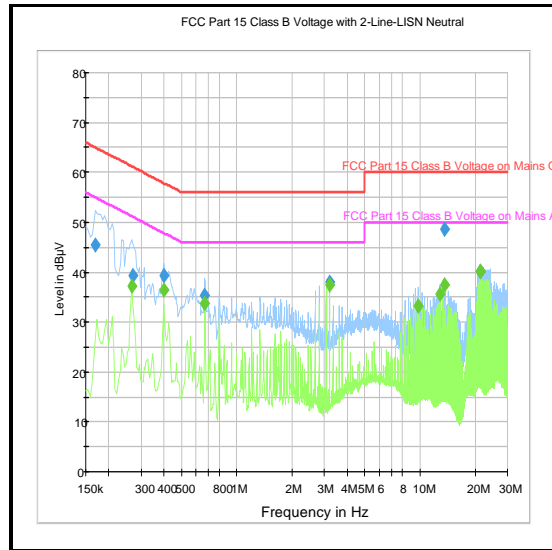

Neutral

Note: These plots are pre-scans and for indication purposes only. For final measurements, see accompanying tables.

Transmitter AC Conducted Spurious Emissions (continued)**Results: Live / Quasi Peak / 240 VAC 60 Hz**

Frequency (MHz)	Line	Level (dB μ V)	Limit (dB μ V)	Margin (dB)	Result
0.267000	Live	41.2	61.2	20.0	Complied
0.402000	Live	42.2	57.8	15.6	Complied
1.923000	Live	33.4	56.0	22.6	Complied
2.679000	Live	39.3	56.0	16.7	Complied
13.555500	Live	43.7	60.0	16.3	Complied
24.112500	Live	39.8	60.0	20.2	Complied

Results: Live / Average / 240 VAC 60 Hz

Frequency (MHz)	Line	Level (dB μ V)	Limit (dB μ V)	Margin (dB)	Result
0.402000	Live	34.7	47.8	13.1	Complied
0.667500	Live	34.4	46.0	11.6	Complied
2.679000	Live	38.6	46.0	7.4	Complied
13.263000	Live	38.5	50.0	11.5	Complied
13.560000	Live	42.6	50.0	7.4	Complied
22.105500	Live	43.3	50.0	6.7	Complied

Results: Neutral / Quasi Peak / 240 VAC 60 Hz

Frequency (MHz)	Line	Level (dB μ V)	Limit (dB μ V)	Margin (dB)	Result
0.267000	Neutral	42.4	61.2	18.8	Complied
0.415500	Neutral	42.4	57.5	15.1	Complied
1.207500	Neutral	35.2	56.0	20.8	Complied
2.679000	Neutral	38.9	56.0	17.1	Complied
13.560000	Neutral	48.9	60.0	11.1	Complied
23.581500	Neutral	41.3	60.0	18.7	Complied

Results: Neutral / Average / 240 VAC 60 Hz

Frequency (MHz)	Line	Level (dB μ V)	Limit (dB μ V)	Margin (dB)	Result
0.267000	Neutral	37.3	51.2	13.9	Complied
0.402000	Neutral	36.7	47.8	11.1	Complied
0.672000	Neutral	34.8	46.0	11.2	Complied
2.679000	Neutral	39.5	46.0	6.5	Complied
13.555500	Neutral	39.1	50.0	10.9	Complied
23.581500	Neutral	40.5	50.0	9.5	Complied

Transmitter AC Conducted Spurious Emissions (continued)

Results: 240 VAC 60 Hz

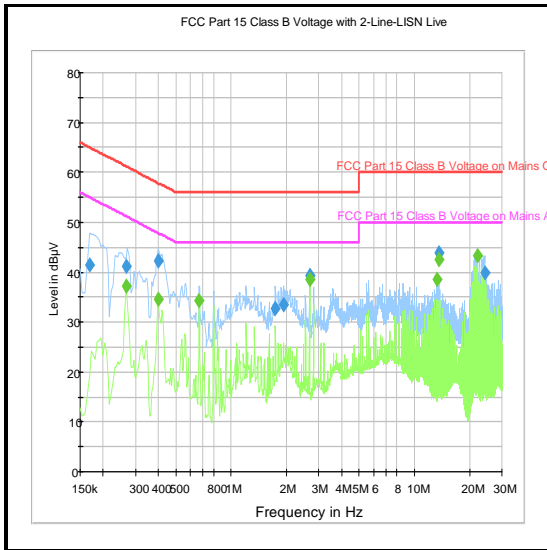

Live

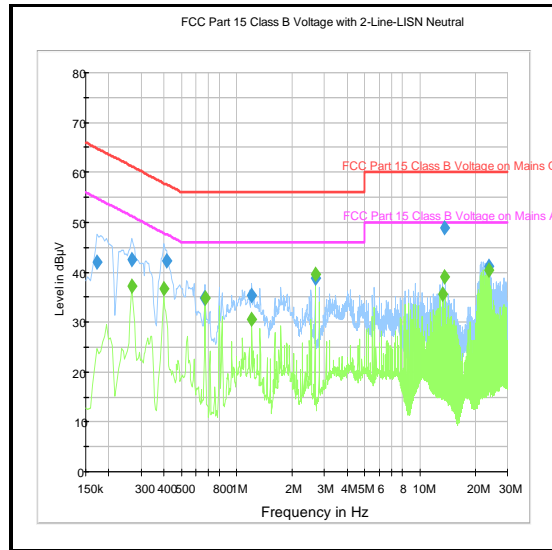

Neutral

Note: These plots are pre-scans and for indication purposes only. For final measurements, see accompanying tables.

Test Equipment Used:

Asset No.	Instrument	Manufacturer	Type No.	Serial No.	Date Calibration Due	Cal. Interval (Months)
M2013	Thermohyrometer	Testo	608-H1	45066419	20 Jun 2018	12
A649	LISN	Rohde & Schwarz	ESH3-Z5	825562/008	31 May 2018	12
A1830	Pulse Limiter	Rohde & Schwarz	ESH3-Z2	100668	09 May 2018	12
M1263	Test Receiver	Rohde & Schwarz	ESIB7	100265	13 Nov 2018	12

5.2.2. Transmitter Fundamental Field Strength**Test Summary:**

Test Engineers:	Ian Watch & Victor Carmon	Test Dates:	20 December 2017 to 02 January 2018
Test Sample Serial Number:	13.56 MHz Tx Mode Sample		

FCC Reference:	Part 15.225(a)(b)(c)(d)
ISED Canada Reference:	RSS-Gen 6.12 / RSS-210 B.6
Test Method Used:	ANSI C63.10 Section 6.4 and Notes below

Environmental Conditions:

Temperature (°C):	9 to 20
Relative Humidity (%):	40 to 87

Note(s):

1. The limit is specified at a test distance of 30 metres. However, as specified by FCC Section 15.31 (f)(2) / RSS-Gen Section 6.4, measurements may be performed at a closer distance and the measured level corrected to the specified measurement distance by using the square of an inverse linear distance extrapolation factor (40dB/decade).
2. It was not possible to determine the emission value at the test distances specified below 30 MHz on an open field test site, therefore in accordance with 47 CFR 15.31(f) / RSS-Gen Section 6.4, measurements were made at closer distances. Attempts were made to measure the fundamental at 30 metres on an open field test site on 20 December 2017. Unfortunately, the fundamental could not be seen above the ambient emissions or the noise floor of the measurement system at a distance of 30 metres, therefore the measurement was repeated at a reduced measurement distance of 3 metres using a measurement bandwidth of 10 kHz.
3. The fundamental field strength level on the open field test site was maximized by rotating the measurement antenna and EUT. A peak level of 64.2 dB μ V/m in a 10 kHz measurement bandwidth, at a measurement distance of 3 metres was recorded and shown on the pre-scan plots below.
4. Further measurements were performed in the semi-anechoic chamber using a test receiver with a peak detector and measurement bandwidth of 10 kHz. An RF level offset of -0.6 dB was used on the test receiver to replicate the result on the open field test site. Refer to results plot '*Fundamental field strength and spectrum mask / measured at 3 metres in a semi-anechoic chamber*'. A further -40 dB was added to the RF level offset to extrapolate the level measured at 3 metres to the required distance of 30 metres.
5. Final measurements were performed in the semi-anechoic chamber in accordance with ANSI C63.10 Clause 4.1.4.2.1 and CISPR 16-1-1, a quasi-peak detector was used in conjunction with a measurement bandwidth of 9 kHz and 0.2 second sweep time. A level of 23.7 dB μ V/m at a measurement distance of 3 metres (extrapolated to 30 metres) was recorded.
6. Background scans of the open field test site and further information are shown in Appendix 1 of this test report.

Transmitter Fundamental Field Strength (continued)**Note(s):**

7. A transducer factor was used on the spectrum analyser during open field tests. This factor includes correction between the fixed gain of the magnetic loop antenna and the calibration values. It also includes the insertion loss of the RF cable used to connect the antenna to the spectrum analyser which was incorporated into the annual calibration of the magnetic loop antenna.
8. For compliance with the spectrum mask, refer to Section 5.2.4 of this test report.
9. Assets M1956 Steel Rule, A2686 Measuring Wheel and A2955 Protractor, were used to support offsite measurements. The calibrated steel rule was used to verify the accuracy of the measuring wheel and the protractor used to ensure the accuracy of the EUT position during testing.

Test setup for fundamental field strength measurements:

Measurements on an Open Field Test Site

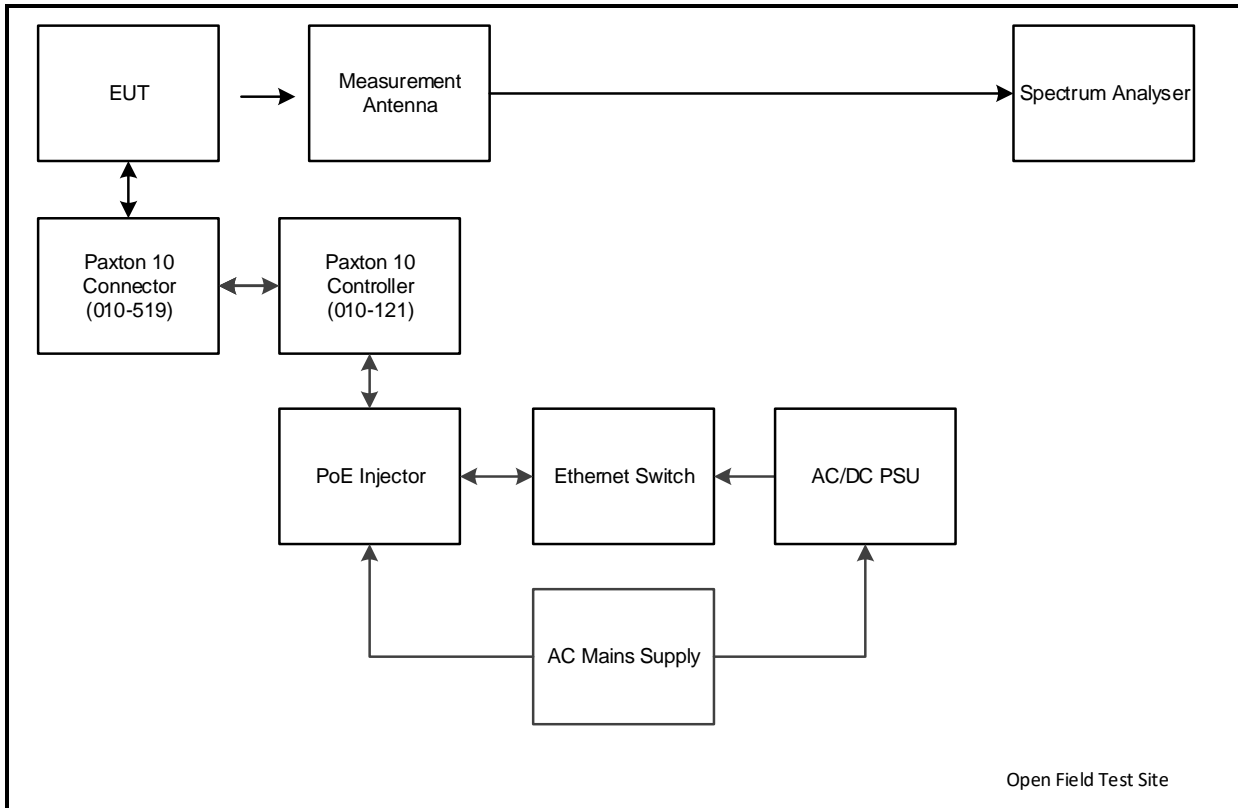

Transmitter Fundamental Field Strength (continued)
Measurements in a semi-anechoic chamber

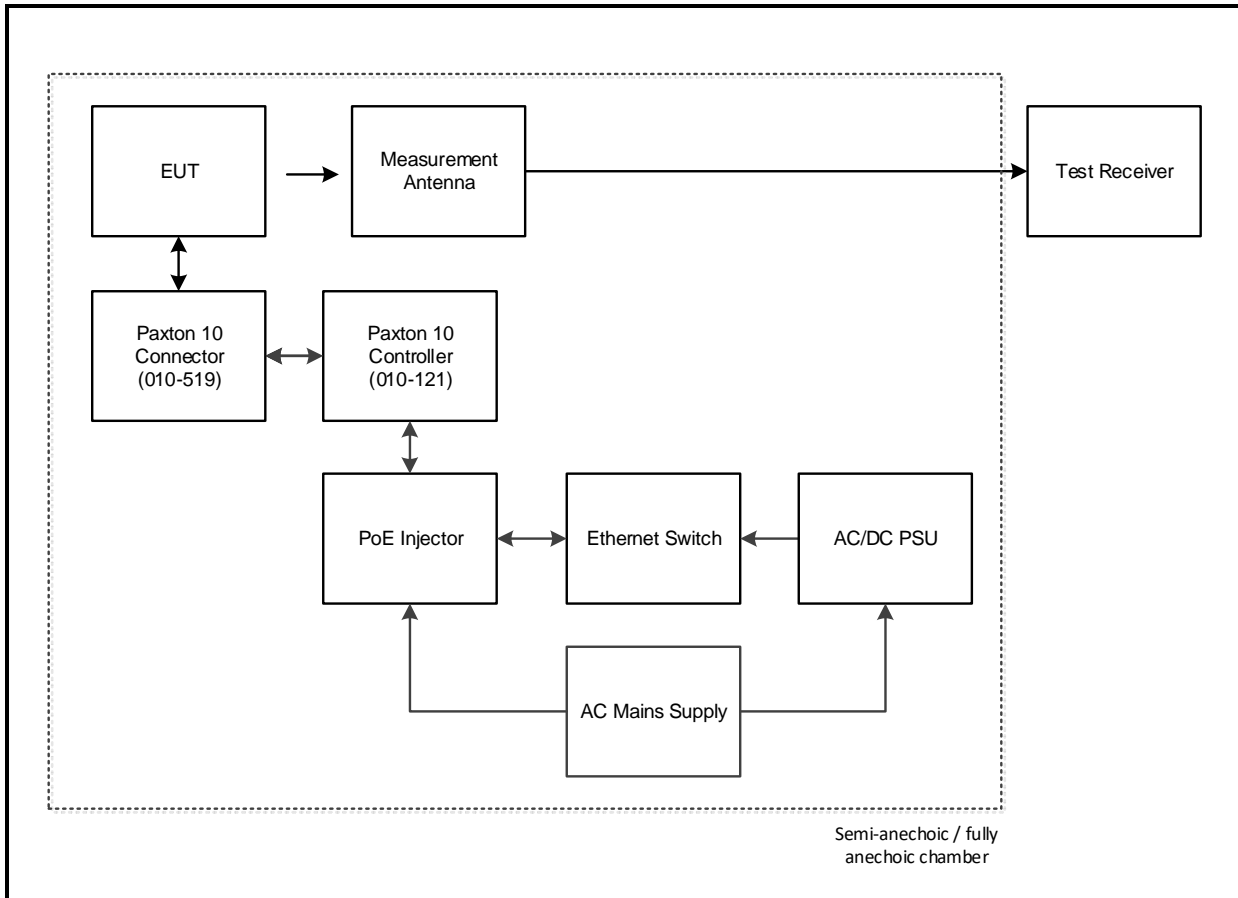

Transmitter Fundamental Field Strength (continued)

Results: Quasi Peak

Frequency (MHz)	Measurement Antenna Position	Level (dB μ V/m)	Limit at 30 m (dB μ V/m)	Margin (dB)	Result
13.56	Tip of antenna 90° from EUT	23.7	84.0	60.3	Complied

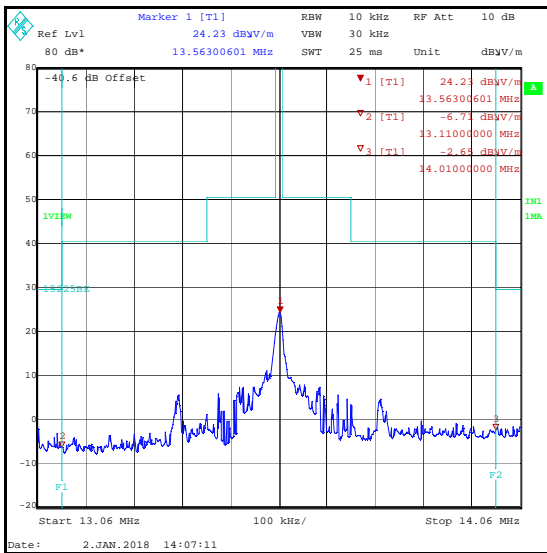

Fundamental field strength and spectrum mask / measured at 3 metres in a semi-anechoic chamber

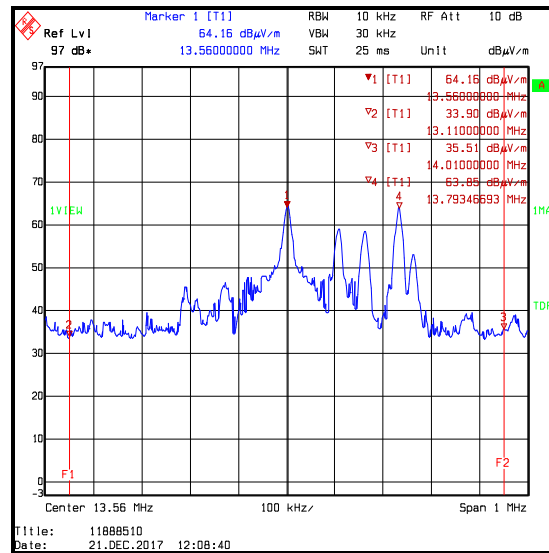

EUT operating / measured at 3 metres on an open field test site

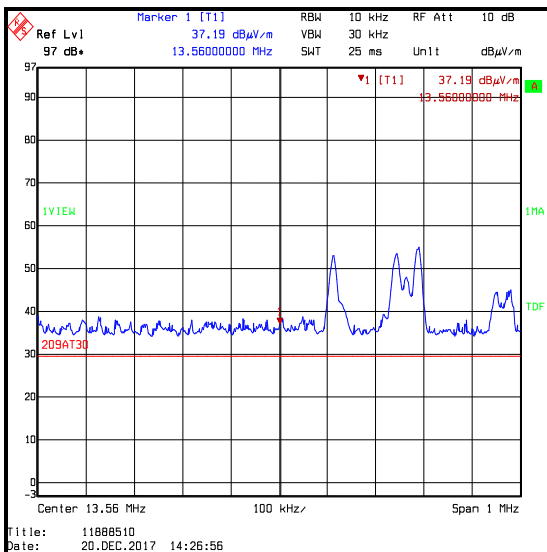

Fundamental field strength / EUT operating / measured at 30 metres / measured on an open field test site with 10 kHz measurement bandwidth (fundamental is below the noise floor)

Transmitter Fundamental Field Strength (continued)**Test Equipment Used:**

Asset No.	Instrument	Manufacturer	Type No.	Serial No.	Date Calibration Due	Cal. Interval (Months)
M2016	Thermohygrometer	Testo	608-H1	45046428	22 Feb 2018	12
M1568	Magnetic Loop Antenna	Rohde & Schwarz	HFH2-Z2	879284/2	08 May 2018	12
M127	Spectrum Analyser	Rohde & Schwarz	FSEB	842659/016	01 Dec 2018	12
M1273	Test Receiver	Rohde & Schwarz	ESIB26	100275	20 Apr 2018	12
M1956	Precision Steel Rule	Rabone	(64SR) 0-35-406	4501361/2204	22 Apr 2020	60
A2686	Distance Measuring Wheel	Rolson	50799	Not stated	Calibrated before use	-
A2955	Protractor	Not marked or stated	9781907550980	#1	Calibration not required	-
K0001	Semi-Anechoic Chamber	Rainford EMC	N/A	N/A	31 Jan 2018	-
M2009	Thermohygrometer	Testo	608-H1	45046699	20 Jun 2018	12

5.2.3. Transmitter Radiated Spurious Emissions

Test Summary:

Test Engineers:	Ian Watch & Victor Carmon	Test Dates:	20 December 2017 to 11 January 2018
Test Sample Serial Number:	13.56 MHz Tx Mode Sample		

FCC Reference:	Parts 15.225(d) & 15.209(a)
ISED Canada Reference:	RSS-Gen 6.13 / RSS-210 B.6
Test Method Used:	ANSI C63.10 Sections 6.3, 6.4 and 6.5 and Notes below
Frequency Range:	9 kHz to 1000 MHz

Environmental Conditions:

Temperature (°C):	9 to 22
Relative Humidity (%):	37 to 87

Note(s):

1. A *bona fide* attempt was made to perform measurements at the distances specified in Part 15.209(a) / RSS Gen Section 8.9 on an open field test site. It was not possible to determine the spurious emission values at the test distances specified below 30 MHz on an open field test site, therefore in accordance with 47 CFR 15.31(f) & RSS-Gen Section 6.4, measurements were made at closer distances. Attempts were made to measure spurious emissions at 3, 30 and 300 metres on an open field test site on 20 December 2017 & 21 December 2017. Unfortunately, spurious emissions from the EUT could not be seen above the ambient emissions present at the open field test site or the noise floor of the measurement system. Tests were repeated at a measurement distance of 3 metres in a semi-anechoic chamber and final measurement result plots from the semi-anechoic chamber tests on 02 January 2018 & 11 January 2018 are shown in this section. In addition, the open field test result plots for measurements between 9 kHz and 30 MHz are also shown. These measurement plots are identical to background scan plots of the open field test site. Background scans of the open field test site and further information are shown in Appendix 1 of this test report.
2. The final measured value, for the given emissions, in the table below incorporates the calibrated antenna factor and cable loss. Only final measurements for spurious emissions in the range 30 MHz to 1 GHz were recorded. Markers were placed on the peaks of the pre-scan plot and final measurements were performed using a quasi-peak detector. Measurements between 30 MHz and 1 GHz were initially made with the EUT and support equipment placed at a height of 0.8 metres above the test chamber floor. Radiated emissions from the support equipment were observed and further testing, including final measurements, were performed with the support equipment placed outside the test chamber.
3. Measurements on 11 January 2018 were performed in a semi-anechoic chamber (UL VS LTD Asset Number K0001) at a distance of 3 metres. The EUT was placed at a height of 80 cm above the reference ground plane in the centre of the chamber turntable. Between 30 MHz and 1 GHz, maximum emission levels were determined by height searching the measurement antenna over the range 1 metre to 4 metres.
4. Measurement plots in this section for tests between 9 kHz and 30 MHz on an open field test site have markers placed on the highest level ambient emissions. This is for information only.
5. All other emissions shown on the pre-scan plots were investigated and found to be >20 dB below the applicable limit or below the measurement system noise floor.
6. A transducer factor was used on the spectrum analyser during open field tests. This factor includes correction between the fixed gain of the magnetic loop antenna and the calibration values. It also includes the value of the RF cable used to connect the antenna to the spectrum analyser which was incorporated into the annual calibration of the magnetic loop antenna.

Transmitter Radiated Spurious Emissions (continued)

Test setup for radiated measurements:

Measurements on an Open Field Test Site

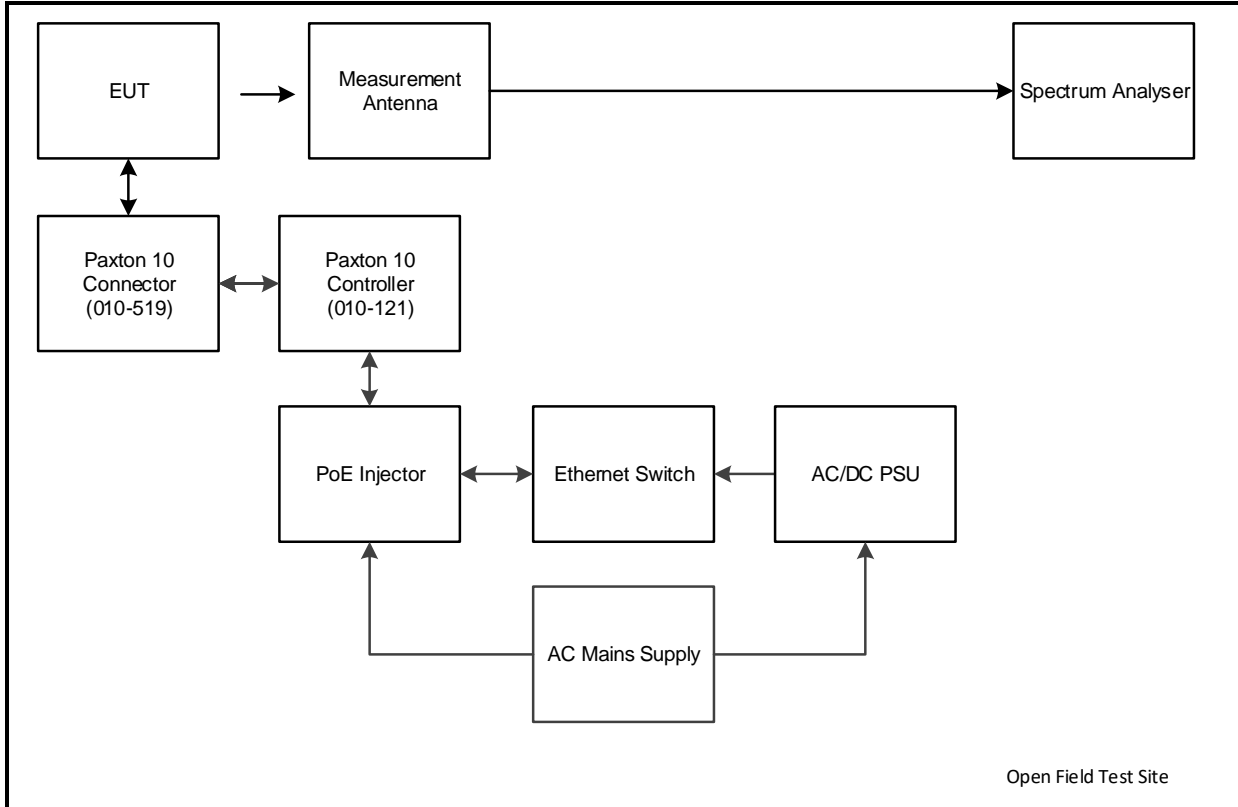

Transmitter Radiated Spurious Emissions (continued)
Measurements below 30 MHz in a semi-anechoic chamber

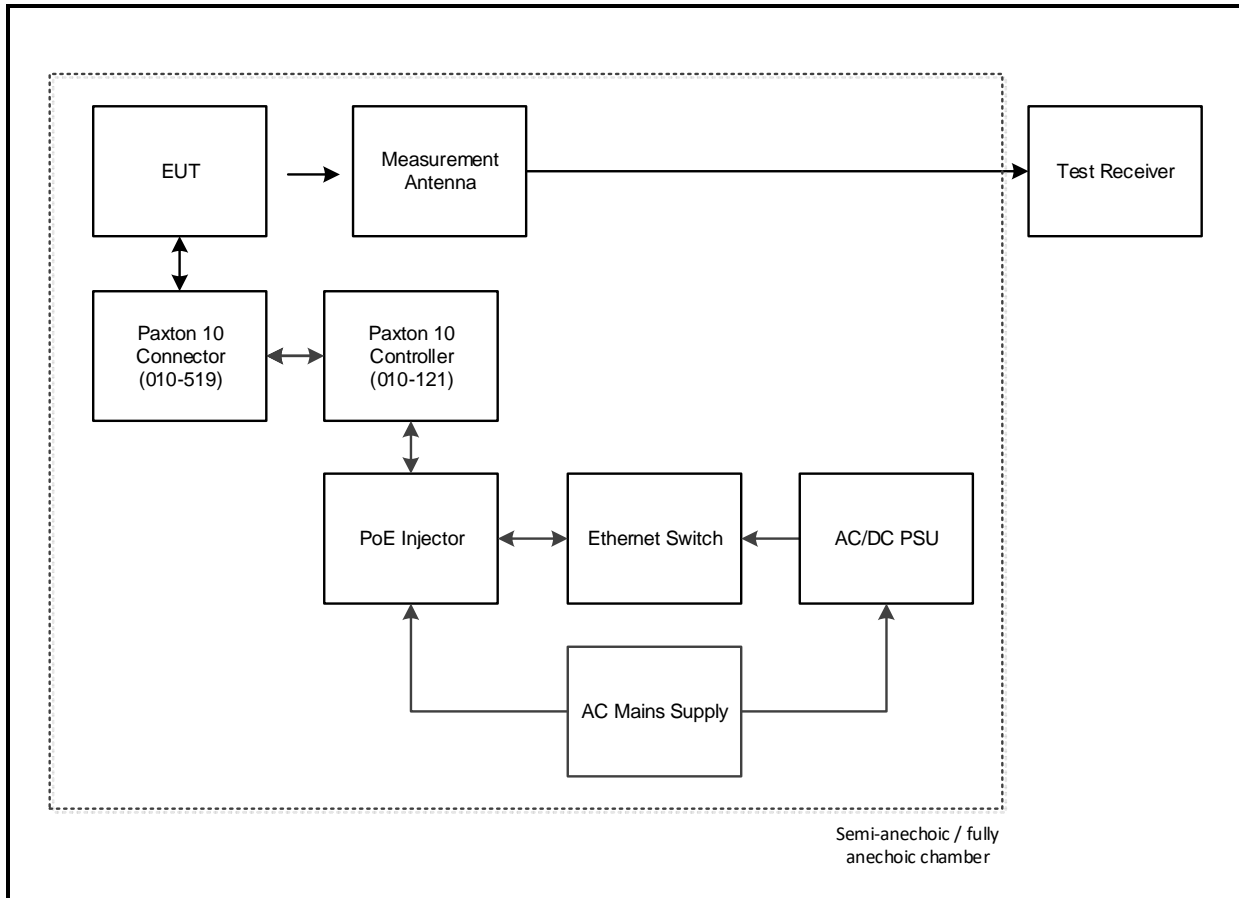

Transmitter Radiated Spurious Emissions (continued)

Measurements above 30 MHz in a semi-anechoic chamber

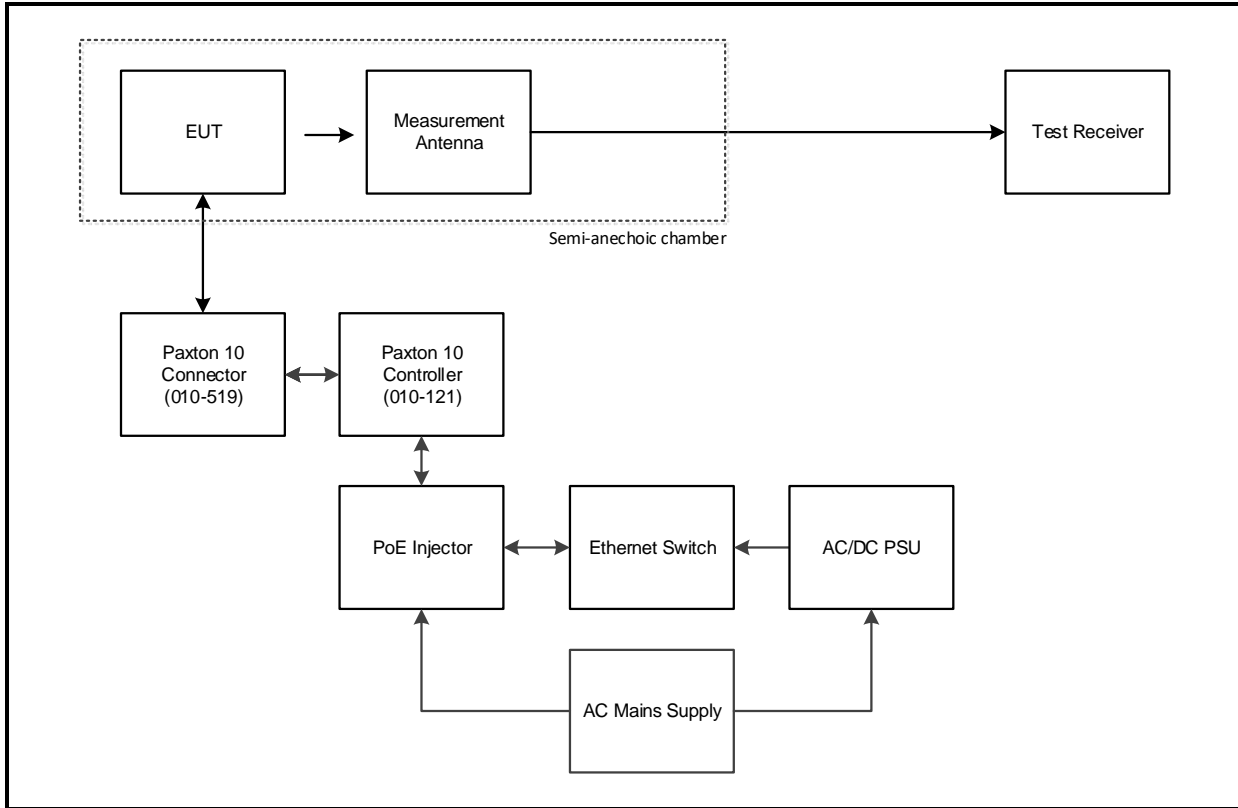

Transmitter Radiated Spurious Emissions (continued)**Results: Quasi Peak**

Frequency (MHz)	Antenna Polarity	Level (dB μ V/m)	Limit (dB μ V/m)	Margin (dB)	Result
40.691	Vertical	33.9	40.0	6.1	Complied
65.659	Vertical	19.4	40.0	20.6	Complied
67.809	Vertical	35.7	40.0	4.3	Complied
75.496	Vertical	29.6	40.0	10.4	Complied
188.243	Horizontal	12.9	43.5	30.6	Complied
250.035	Vertical	31.9	46.0	14.1	Complied

Transmitter Radiated Spurious Emissions (continued)

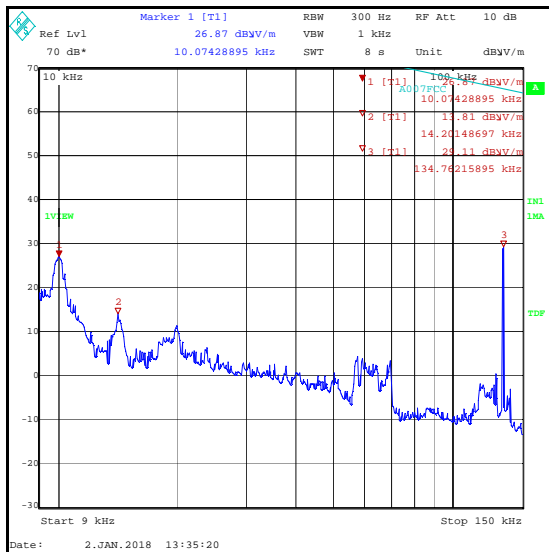

9 kHz to 150 kHz / peak detector / measured at 3 metres extrapolated to 30 metres / measured in a semi-anechoic chamber

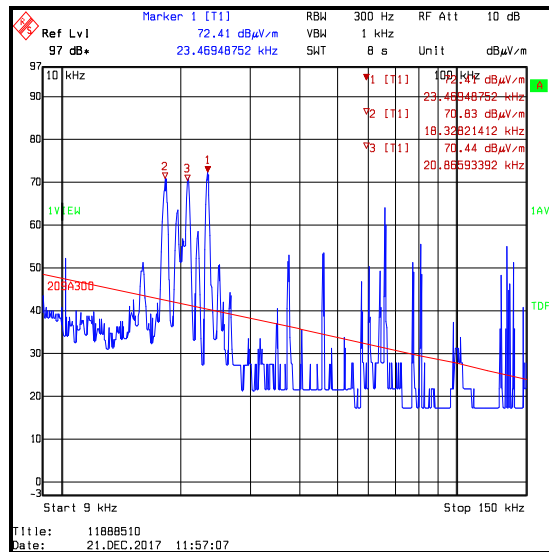

9 kHz to 150 kHz / average detector / EUT operating / measured at 3 metres on an open field test site

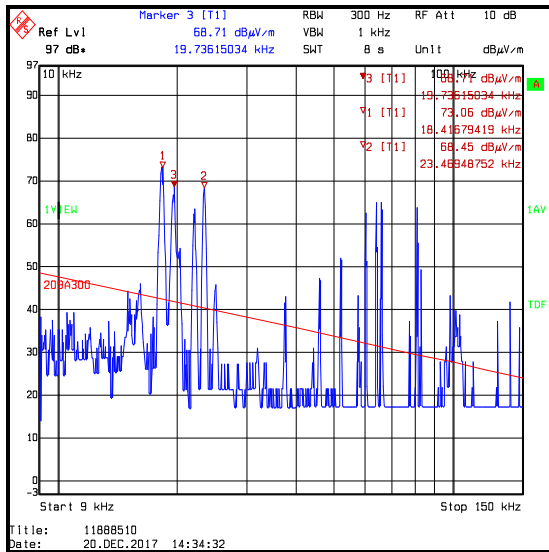

9 kHz to 150 kHz / average detector / EUT operating / measured at 30 metres on an open field test site

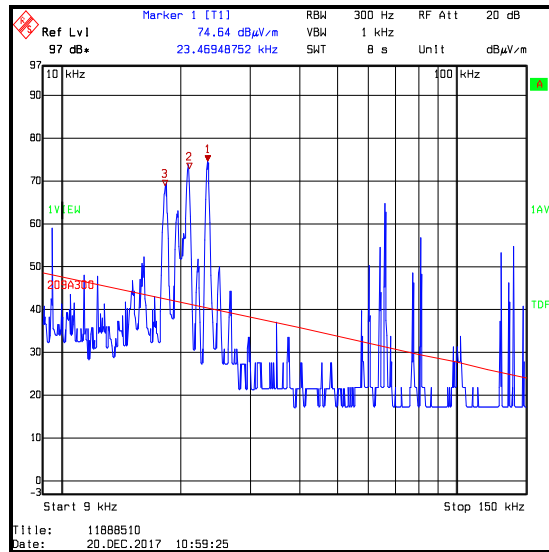

9 kHz to 150 kHz / average detector / EUT operating / measured at 300 metres on an open field test site

Note: These plots are pre-scans and for indication purposes only. For final measurements, see accompanying table.

Transmitter Radiated Spurious Emissions (continued)

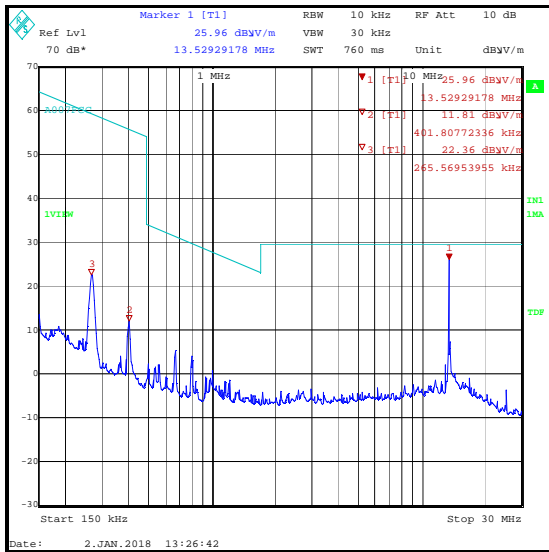

150 kHz to 30 MHz / peak detector (worst case) / EUT operating / measured at 3 metres extrapolated to 30 metres / measured in a semi-anechoic chamber

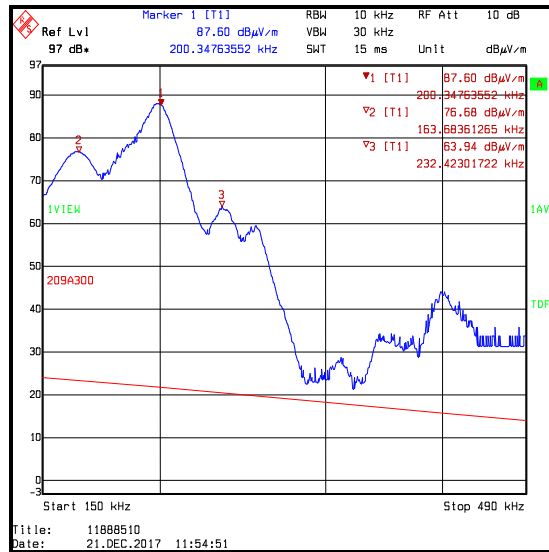

150 kHz to 490 kHz / average detector / EUT operating / measured at 3 metres on an open field test site



150 kHz to 490 kHz / average detector / EUT operating / measured at 30 metres on an open field test site

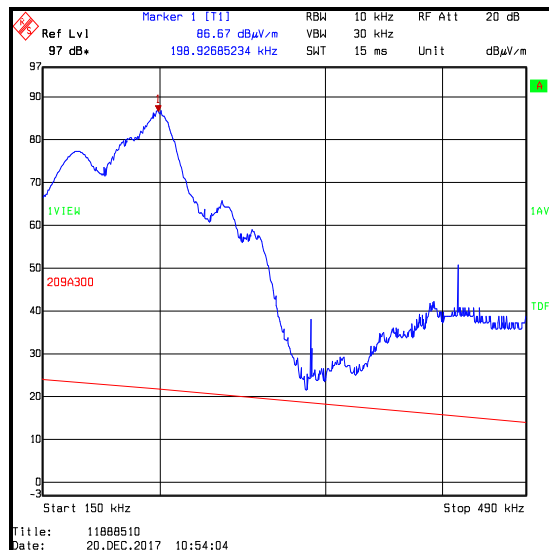

150 kHz to 490 kHz / average detector / EUT operating / measured at 300 metres on an open field test site

Note: These plots are pre-scans and for indication purposes only. For final measurements, see accompanying table.

Transmitter Radiated Spurious Emissions (continued)

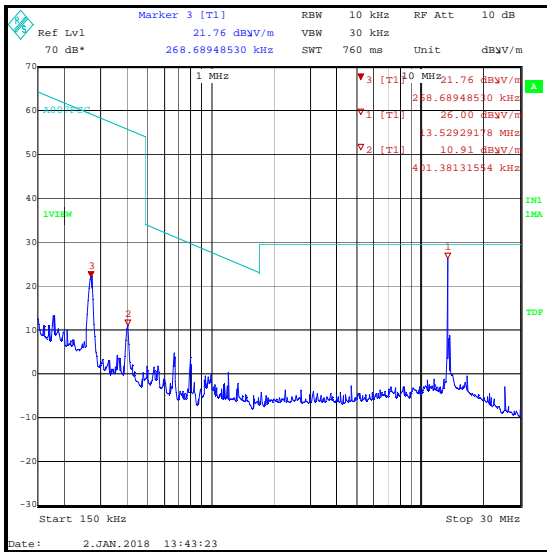

150 kHz to 30 MHz / peak detector / measured at 3 metres extrapolated to 30 metres / measured in a semi-anechoic chamber

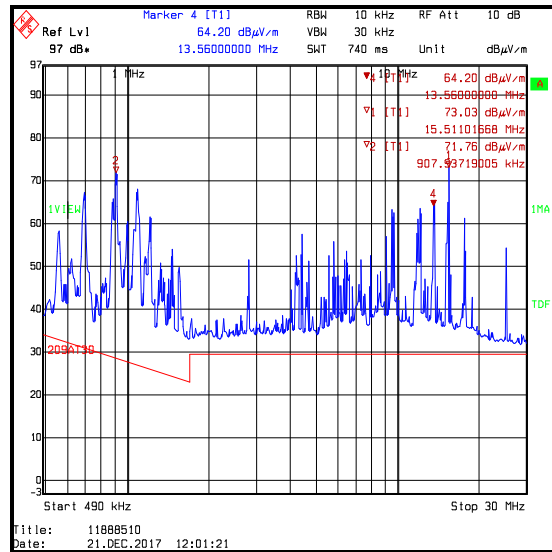

490 kHz to 30 MHz / peak detector / EUT operating / measured at 3 metres on an open field test site

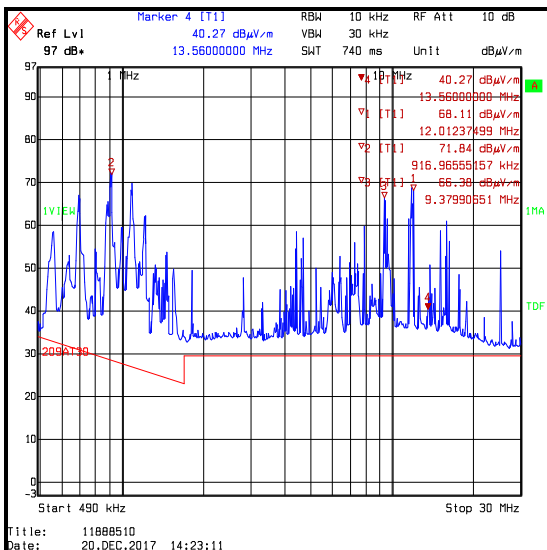

490 kHz to 30 MHz / peak detector / EUT operating / measured at 30 metres on an open field test site

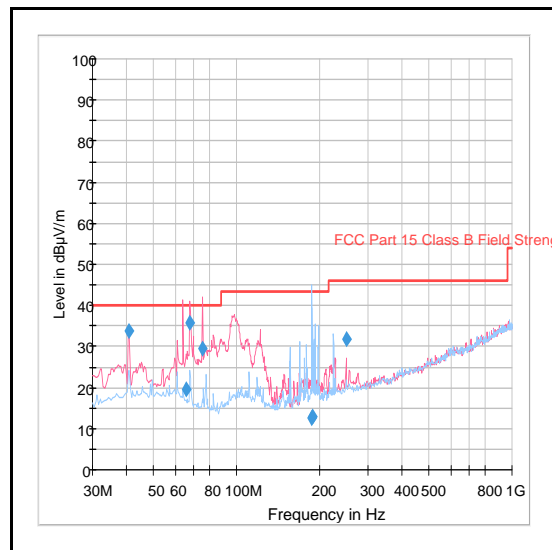

30 MHz to 1 GHz / peak detector (worst case) / measured at 3 metres in a semi-anechoic chamber

Note: These plots are pre-scans and for indication purposes only. For final measurements, see accompanying table.

Transmitter Radiated Spurious Emissions (continued)**Test Equipment Used:**

Asset No.	Instrument	Manufacturer	Type No.	Serial No.	Date Calibration Due	Cal. Interval (Months)
M2016	Thermohygrometer	Testo	608-H1	45046428	22 Feb 2018	12
M2009	Thermohygrometer	Testo	608-H1	45046699	20 Jun 2018	12
M1568	Magnetic Loop Antenna	Rohde & Schwarz	HFH2-Z2	879284/2	08 May 2018	12
A1834	Attenuator	Hewlett Packard	8491B	104444	23 Feb 2018	12
M127	Spectrum Analyser	Rohde & Schwarz	FSEB	842659/016	01 Dec 2018	12
A2959	Antenna	Schwatzbeck	VULB 9163	9613-967	16 Nov 2018	12
G0543	Preamplifier	Sonama	310N	230801	15 Jun 2018	12
M1273	Test Receiver	Rohde & Schwarz	ESIB26	100275	20 Apr 2018	12
M1956	Precision Steel Rule	Rabone	(64SR) 0-35-406	4501361/2204	22 Apr 2020	60
A2686	Distance Measuring Wheel	Rolson	50799	Not stated	Calibrated before use	-
A2955	Protractor	Not marked or stated	9781907550980	#1	Calibration not required	-
K0001	Semi-Anechoic Chamber	Rainford EMC	N/A	N/A	31 Jan 2018	12
M2009	Thermohygrometer	Testo	608-H1	45046699	20 Jun 2018	12

5.2.4. Transmitter Band Edge Radiated Emissions**Test Summary:**

Test Engineers:	Ian Watch & Victor Carmon	Test Dates:	21 December 2017 & 02 January 2018
Test Sample Serial Number:	13.56 MHz Tx Mode Sample		

FCC Reference:	Parts 15.225(c)(d) & 15.209(a)
ISED Canada Reference:	RSS-Gen 6.13 / RSS-210 B.6
Test Method Used:	ANSI C63.10 Section 6.4 and Notes below

Environmental Conditions:

Temperature (°C):	9 to 20
Relative Humidity (%):	40 to 87

Note(s):

1. A *bona fide* attempt was made to perform measurements at the distances specified in Part 15.209(a) / RSS Gen Section 8.9. It was not possible to determine the band edge emission values at the test distances specified below 30 MHz on an open field test site due to the presence of ambient emissions, therefore in accordance with 47 CFR 15.31(f) / RSS-Gen Section 6.4, measurements were made at closer distances. Attempts were made to measure the fundamental and band edges at a distance of 30 metres on an open field test site on 21 December 2017. Unfortunately, the emission could not be seen above the ambient emissions or the noise floor of the measurement system at 30 metres and the test was repeated on the open field site at a distance of 3 metres. Background scans of the open field test site are shown in Appendix 1 of this test report.
2. The measurement was repeated in a semi-anechoic chamber at a distance of 3 metres. An RF level offset on the test receiver was used to replicate the fundamental field strength level measured at 3 metres on an open field test site and an additional -40 dB was incorporated to extrapolate the measured level to the required measurement distance of 30 metres.
3. The test receiver resolution bandwidth was set to 10 kHz and video bandwidth 30 kHz. A peak detector was used, sweep time was set to auto and the trace mode was Max Hold. The span was set to 1 MHz. Markers were placed at the lower and upper band edges. The results are given in the tables below.
4. The test setup was the same as radiated spurious emissions tests.

Transmitter Band Edge Radiated Emissions (continued)

Results: Peak / Lower Band Edge

Frequency (MHz)	Level (dBµV/m)	Limit (dBµV/m)	Margin (dB)	Result
13.11	-6.7	29.5	36.2	Complied

Results: Peak / Upper Band Edge

Frequency (MHz)	Level (dBµV/m)	Limit (dBµV/m)	Margin (dB)	Result
14.01	-2.6	29.5	32.1	Complied

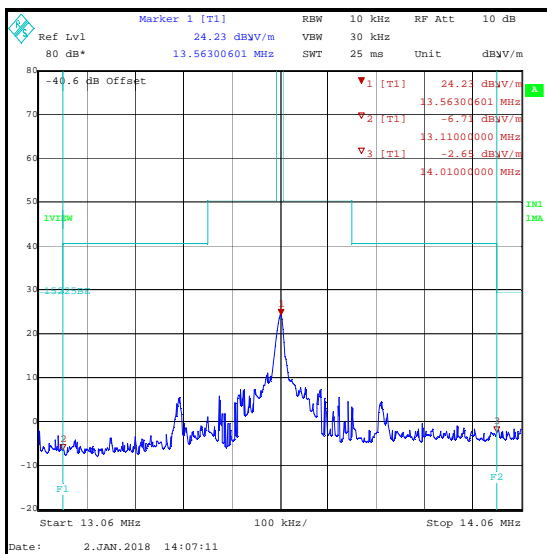

EUT operating / measured at 3 metres extrapolated to 30 metres / measured in a semi-anechoic chamber

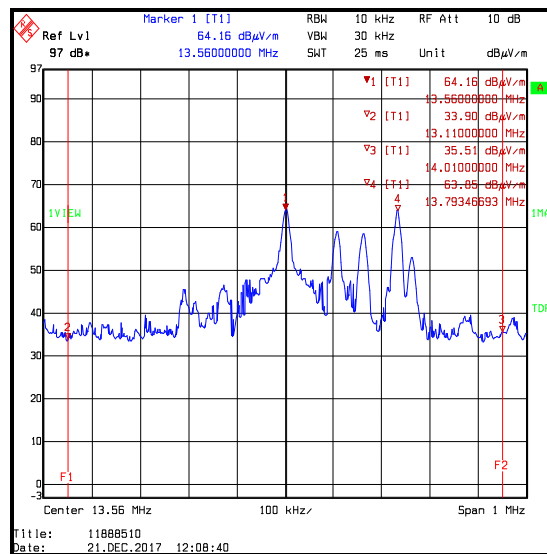

EUT operating / measured at 3 metres on an open field test site

Test Equipment Used:

Asset No.	Instrument	Manufacturer	Type No.	Serial No.	Date Calibration Due	Cal. Interval (Months)
M2016	Thermohygrometer	Testo	608-H1	45046428	22 Feb 2018	12
M1568	Magnetic Loop Antenna	Rohde & Schwarz	HFH2-Z2	879284/2	08 May 2018	12
M127	Spectrum Analyser	Rohde & Schwarz	FSEB	842659/016	01 Dec 2018	12
M1273	Test Receiver	Rohde & Schwarz	ESIB26	100275	20 Apr 2018	12
M1956	Precision Steel Rule	Rabone	(64SR) 0-35-406	4501361/2204	22 Apr 2020	60
A2686	Distance Measuring Wheel	Rolson	50799	Not stated	Calibrated before use	-
A2955	Protractor	Not marked or stated	9781907550980	#1	Calibration not required	-
K0001	Semi-Anechoic Chamber	Rainford EMC	N/A	N/A	31 Jan 2018	-
M2009	Thermohygrometer	Testo	608-H1	45046699	20 Jun 2018	12

5.2.5. Transmitter 99% Emission Bandwidth

Test Summary:

Test Engineers:	Ian Watch & Victor Carmon	Test Date:	18 January 2018
Test Sample Serial Number:	13.56 MHz TX mode sample		

FCC Reference:	N/A
ISED Canada Reference:	RSS-Gen 6.6
Test Method Used:	ANSI C63.10 Section 6.9.2

Environmental Conditions:

Temperature (°C):	24
Relative Humidity (%):	35

Note(s):

1. 99% Occupied bandwidth was measured using the 99% occupied bandwidth function of a spectrum analyser.

Test setup:

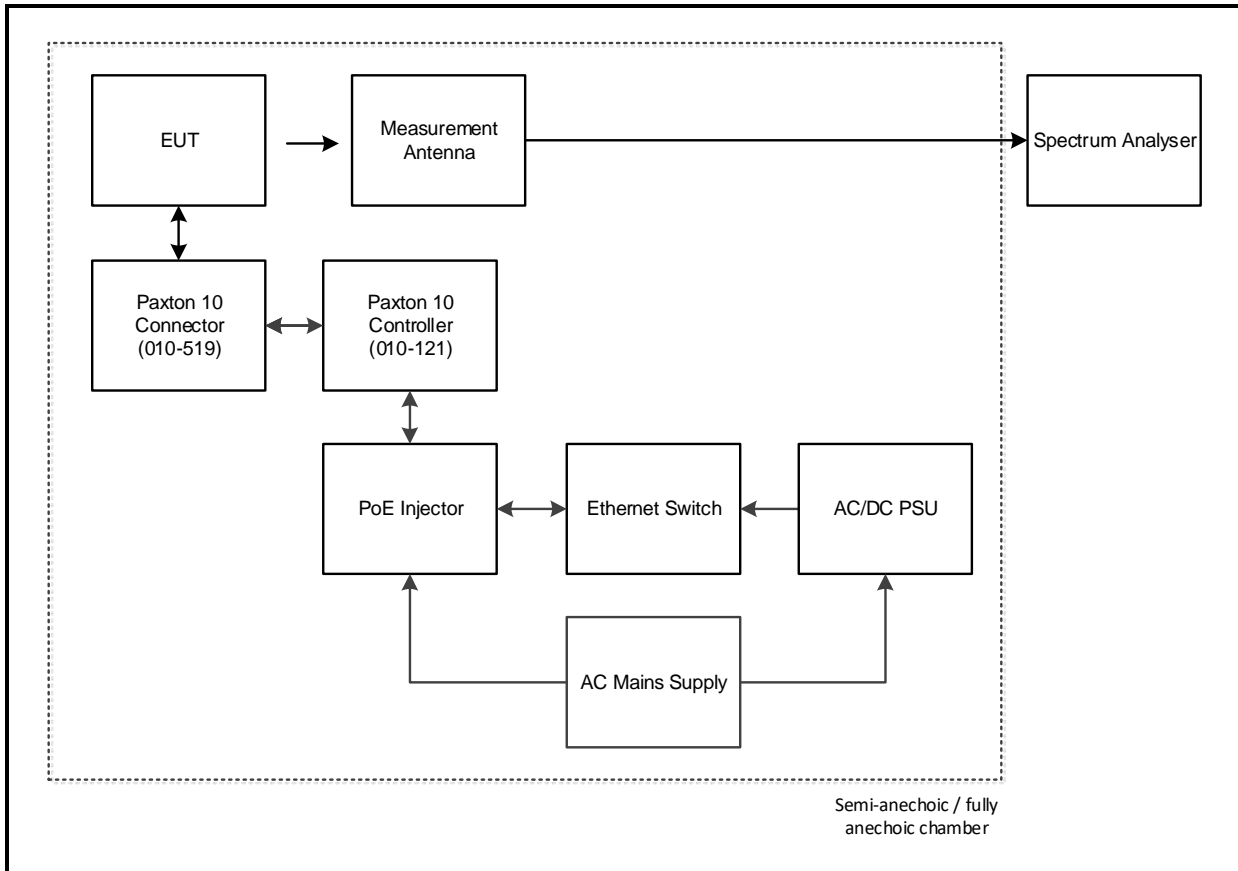

Transmitter 99% Emission Bandwidth (continued)

Results:

99% Emission Bandwidth (kHz)
1403

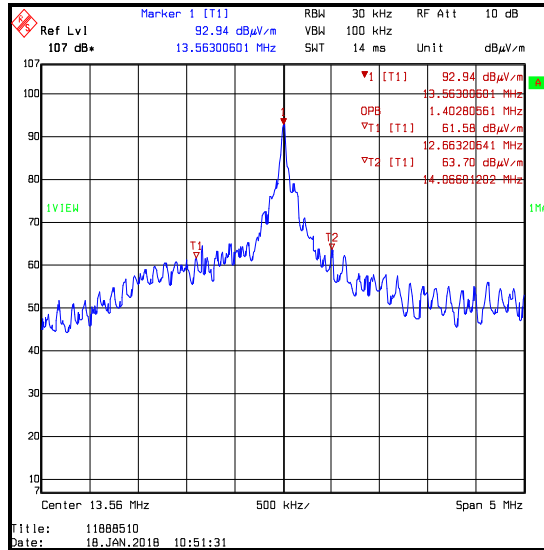

Test Equipment Used:

Asset No.	Instrument	Manufacturer	Type No.	Serial No.	Date Calibration Due	Cal. Interval (Months)
M2009	Thermohygrometer	Testo	608-H1	45046699	20 Jun 2018	12
K0001	Semi-Anechoic Chamber	Rainford EMC	N/A	N/A	31 Jan 2018	12
M127	Spectrum Analyser	Rohde & Schwarz	FSEB	842659/016	01 Dec 2018	12
M1568	Magnetic Loop Antenna	Rohde & Schwarz	HFH2-Z2	879284/2	08 May 2018	12

5.2.6. Transmitter Frequency Stability (Temperature & Voltage Variation)**Test Summary:**

Test Engineers:	Ian Watch & Victor Carmon	Test Date:	12 January 2018
Test Sample Serial Number:	System 2 13.56 MHz TX mode sample		

FCC Reference:	Part 15.225(e)
ISED Canada Reference:	RSS-Gen 6.11 / RSS-210 B.6
Test Method Used:	ANSI C63.10 Sections 6.8.1 and 6.8.2

Environmental Conditions:

Ambient Temperature (°C):	22 to 24
Ambient Relative Humidity (%):	35

Note(s):

1. Testing at voltage extremes was performed with the system powered by a variable AC power supply.
2. Frequency stability measurements were performed with a modulated carrier. The measurements were performed using the spectrum analyser marker counter function. The marker counter function was set to 1 Hz before any measurements were performed.
3. Frequency error was measured using a calibrated Rohde & Schwarz test receiver.
4. Temperature was monitored throughout the test with a calibrated digital thermometer.
5. Voltage was monitored throughout the test with a calibrated digital voltmeter.

Transmitter Frequency Stability (Temperature & Voltage Variation) (continued)

Test setup:

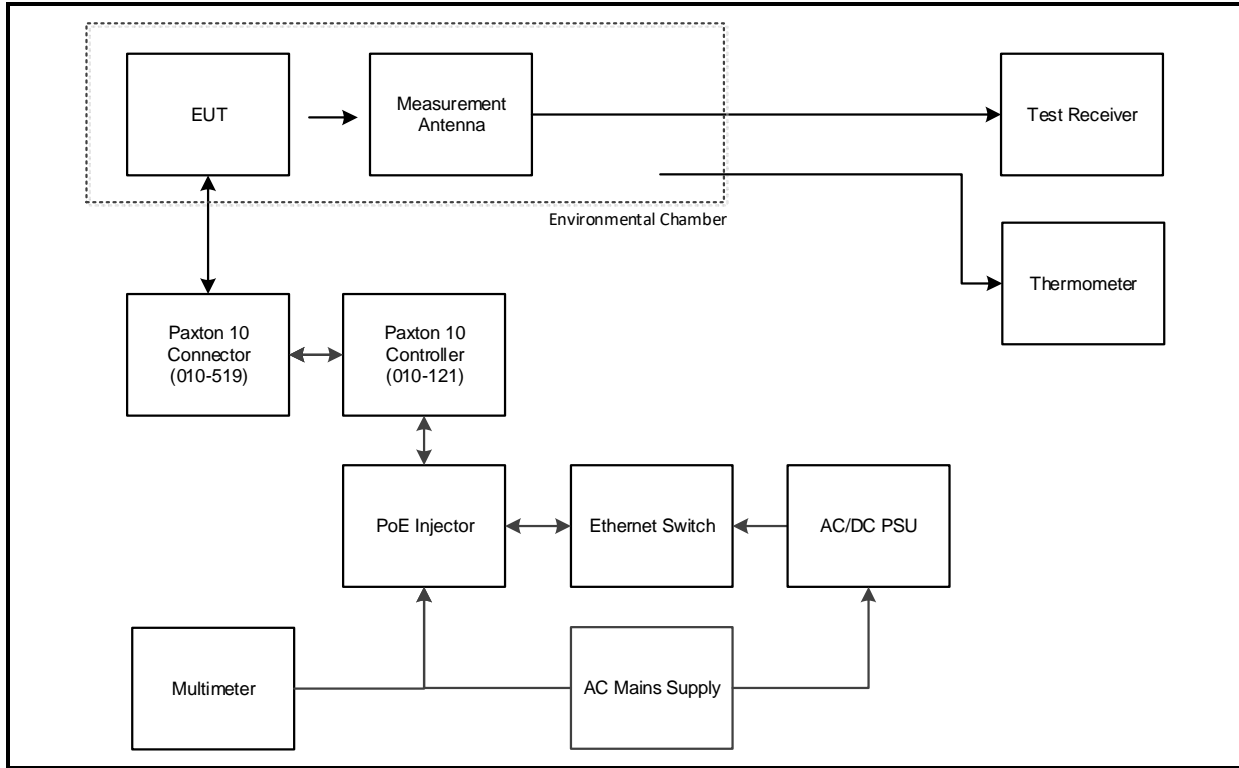

Transmitter Frequency Stability (Temperature & Voltage Variation) (continued)**Results: Maximum frequency error of the EUT with variations in ambient temperature**

Temperature (°C)	Time after Start-up			
	0 minutes	2 minutes	5 minutes	10 minutes
-20	13.559804 MHz	13.559765 MHz	13.559803 MHz	13.559811 MHz
20	13.559766 MHz	13.559754 MHz	13.559763 MHz	13.559762 MHz
55	13.559672 MHz	13.559733 MHz	13.559708 MHz	13.559778 MHz

Frequency with Worst Case Deviation (MHz)	Frequency Error (Hz)	Frequency Error (%)	Limit (%)	Margin (%)	Result
13.559672	328	0.0024	0.01	0.0076	Complied

Results: Maximum frequency error of the EUT with variations in nominal operating voltage at an ambient temperature of 20°C

Supply Voltage (V)	Nominal Frequency (MHz)	Measured Frequency (MHz)	Frequency Error (Hz)	Frequency Error (%)	Limit (%)	Margin (%)	Result
102	13.56	13.559763	237	0.0017	0.01	0.0083	Complied
120	13.56	13.559762	238	0.0018	0.01	0.0082	Complied
138	13.56	13.559730	270	0.0020	0.01	0.0080	Complied

Test Equipment Used:

Asset No.	Instrument	Manufacturer	Type No.	Serial No.	Date Calibration Due	Cal. Interval (Months)
M1656	Thermohygrometer	JM Handelspunkt	30.5015.13	None stated	22 Feb 2018	12
M1815	Environmental Chamber	Votsch	VT4002	521/83083	Calibrated before use	-
M1643	Thermometer	Fluke	52II	18890136	20 Apr 2018	12
S0539	Variable AC Power Supply	Kikusui	PCR 1000L	13010170	Calibrated before use	-
M122	Multimeter	Fluke	77	64910017	26 Apr 2018	12
M1874	Test Receiver	Rohde & Schwarz	ESU26	100553	28 Nov 2018	12

6. Measurement Uncertainty

No measurement or test can ever be perfect and the imperfections give rise to error of measurement in the results. Consequently the result of a measurement is only an approximation to the value of the measurand (the specific quantity subject to measurement) and is only complete when accompanied by a statement of the uncertainty of the approximation.

The expression of uncertainty of a measurement result allows realistic comparison of results with reference values and limits given in specifications and standards.

The uncertainty of the result may need to be taken into account when interpreting the measurement results.

The reported expanded uncertainties below are based on a standard uncertainty multiplied by an appropriate coverage factor such that a confidence level of approximately 95% is maintained. For the purposes of this document "approximately" is interpreted as meaning "effectively" or "for most practical purposes".

Measurement Type	Range	Confidence Level (%)	Calculated Uncertainty
AC Conducted Spurious Emissions	0.15 MHz to 30 MHz	95%	±4.69 dB
Frequency Stability	13 MHz to 14 MHz	95%	±1.62 ppm
99% Emission Bandwidth	13 MHz to 14 MHz	95%	±3.92 %
Radiated Spurious Emissions	9 kHz to 30 MHz	95%	±4.39 dB
Radiated Spurious Emissions	30 MHz to 1000 MHz	95%	±2.94 dB
Transmitter Fundamental Field Strength	13 MHz to 14 MHz	95%	±4.39 dB

The methods used to calculate the above uncertainties are in line with those recommended within the various measurement specifications. Where measurement specifications do not include guidelines for the evaluation of measurement uncertainty the published guidance of the appropriate accreditation body is followed.

7. Report Revision History

Version Number	Revision Details		
	Page No(s)	Clause	Details
1.0	-	-	Initial Version

8. Appendix 1

GPS coordinates of test location

Mag loop location (lower marker on photo)

N51° 08.739' W001° 26.328'

30 metre test point (middle marker on photo)

N51° 08.755' W001° 26.325'

300 metre test point (upper marker on photo)

N51° 08.895' W001° 26.289'



Details of 3 metre and 30 metre open field test site used on 20 December 2017 & 21 December 2017

Temperature: 9 °C to 16 °C

Relative Humidity: 71% to 84%

Ground conditions: Wet

Measurements at 3 and 30 metres

The test site was free from underground metal objects.

The EUT was powered at its nominal voltage from its power supply. The power supply was connected to a single phase supply from a portable generator. A power cable was run across the field to the EUT. An RCD was fitted to the power source. The generator was located 50 metres from the EUT and surrounded by radio absorbent material. For safety purposes, an RCD was fitted to the generator output.

The EUT was placed on a plastic table at a height of 0.8 metres above ground level. All associated cables and support equipment were arranged according to ANSI C63.10-2013 Section 6.12.

The spectrum analyser used for measurements was located in a vehicle 30 metres from the magnetic loop antenna. Power to the test equipment was from a single phase supply.

The test distance was from the centre of the mag loop antenna to the closest periphery of the EUT. This distance was maintained as the EUT was rotated.

Initially, The EUT was rotated through 360 degrees in 60 degree steps at both measurement distances. The mag loop antenna was rotated through 90 degrees in 30 degree steps at every position the EUT was moved to. The EUT and mag loop antenna were then rotated in small increments in order to maximise emission levels.

Details of 300 metre open field test site used on 20 December 2017 & 21 December 2017

Temperature: 9 °C to 16 °C

Relative Humidity: 71% to 84%

Ground conditions: Wet

Measurements at 300 metres

The test site was free from underground metal objects.

The EUT was powered at its nominal voltage from its PoE power supply. The power supply was connected to a single phase supply from a portable generator. A power cable was run across the field to the EUT. An RCD was fitted to the power source. The generator was located 50 metres from the EUT and surrounded by radio absorbent material. For safety purposes, an RCD was fitted to the generator output.

The EUT was placed on a plastic table at a height of 0.8 metres above ground level. All associated cables were arranged according to ANSI C63.10-2013 Section 6.12.

The spectrum analyser used for measurements was located in a vehicle 30 metres from the magnetic loop antenna. Power to the test equipment was from a single phase agricultural supply.

The test distance was from the centre of the mag loop antenna to the closest periphery of the EUT. This distance was maintained as the EUT was rotated.

Initially, The EUT was rotated through 360 degrees in 60 degree steps at both measurement distances. The mag loop antenna was rotated through 90 degrees in 30 degree steps at every position the EUT was moved to. The EUT and mag loop antenna were then rotated in small increments in order to maximise emission levels.

Comparison of open field test site with semi-anechoic chamber measurements at 3 metres

Radiated measurements were performed on an open field test site and within a 5 metre semi-anechoic chamber.

For the signal source, a modified loop antenna was connected to a signal generator at the transmit side. A standard active magnetic loop antenna was connected to a spectrum analyser at the receive side. The signal generator was set to its maximum supported output power and the signal was transmitted to the spectrum analyser via the two antennas and associated RF cables.

A sweep in small frequency increments was performed from 9 kHz to 30 MHz. The sweep was repeatedly performed with both antennas rotated about the axis in various orientations. Received levels for all orientations were recorded and the maximum levels for the open field test site and the semi-anechoic chamber are shown on the graph below. Full data for both tests are archived on the UL VS LTD IT server and available for inspection on request.

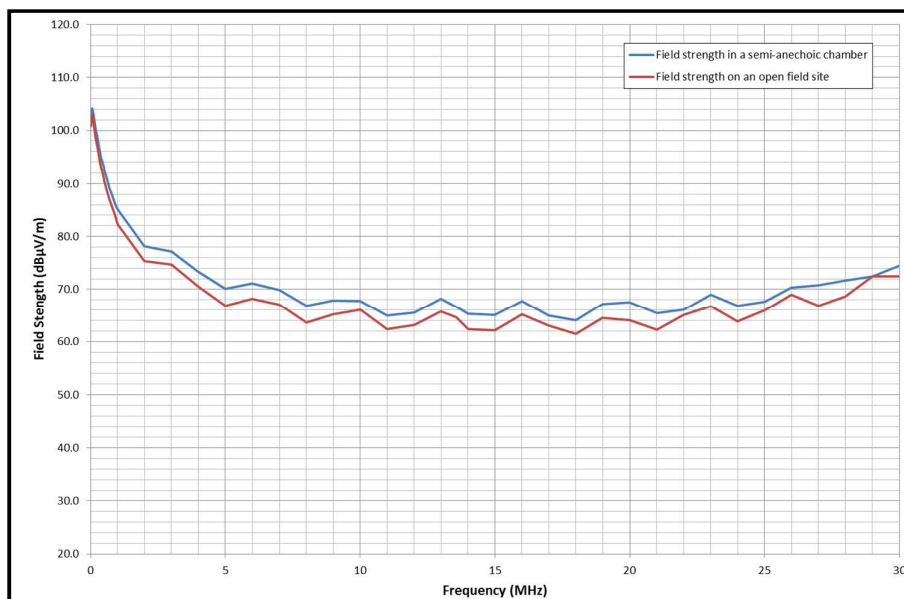

The conclusion was that the open field test site compares well with the semi-anechoic chamber at a measurement distance of 3 metres. If anything, the semi-anechoic chamber results are generally slightly higher. This means that if the measurement passes in the semi-anechoic chamber, it will pass with a higher margin on an open field test site.

The magnetic loop antenna used to perform these measurements is the same antenna or same type of antenna used during measurements contained in this test report.

Verification of open field test site and semi-anechoic chamber measurements at 3 metres prior to performing measurements

Two reference units are used for verification of the measurement system before testing commences. Both reference units are door entry systems modified by the manufacturer for test purposes only.

One reference unit transmits a continuous, unmodulated signal at a fixed frequency of 125 kHz when a 12 Volt battery is connected. The output power is fixed and known to be stable.

The second transmits a continuous, unmodulated signal at a fixed frequency of 13.56 MHz when a 12 Volt battery is connected. The output power is fixed and known to be stable.

Both frequencies are commonly used RFID frequencies.

A UL VS LTD internal verification document explains the procedure in detail. A brief description is given below.

The centre of the magnetic loop antenna is placed exactly 3 metres from the reference unit. The reference unit is placed on a plastic table at a height of 0.8 metres above floor level and the centre of the mag loop antenna is 1 metre above the floor level. The mag loop antenna and reference unit are oriented in certain positions to ensure repeatability.

Each reference unit is connected to a 12 Volt battery and once transmitting, the maximum raw received level at each of the two frequencies is read on the spectrum analyser by using the marker peak function. The measured level has to be within certain levels as specified in the UL VS LTD internal test procedure. The plot of the verification measurement is archived on the UL VS LTD IT server. The peak level of each reference unit is recorded on a spreadsheet which is also archived on the UL VS LTD IT server.

The internal verification procedure and verification plots are available for inspection on request.

Radiated measurements below 30 MHz were performed in a semi-anechoic chamber at a distance of 3 metres.

Verification plots of the two reference units at a measurement distance of 3 metres are shown on the following page. Plots were taken on an open field test site (20 December 2017) and in a semi-anechoic chamber (02 January 2018).

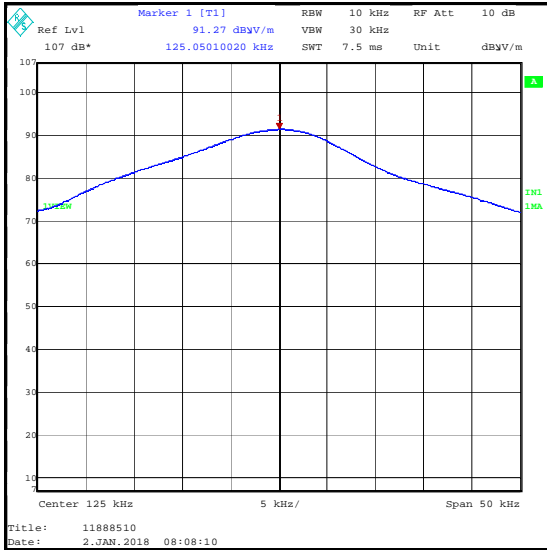

125 kHz reference unit signal at 3 metres in a semi-anechoic chamber on 02 January 2018

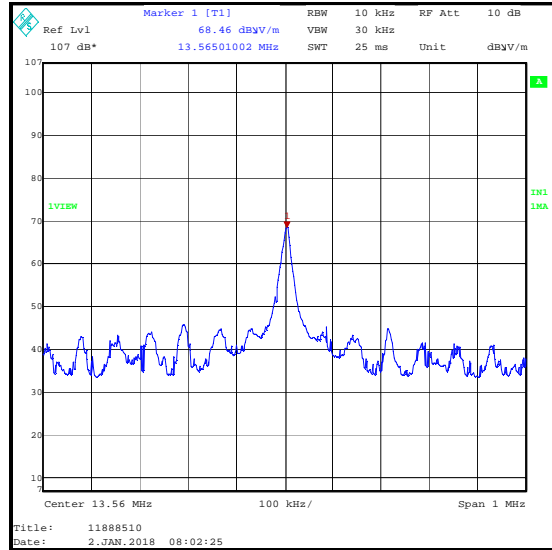

13.56 MHz reference unit signal at 3 metres in a semi-anechoic chamber on 02 January 2018

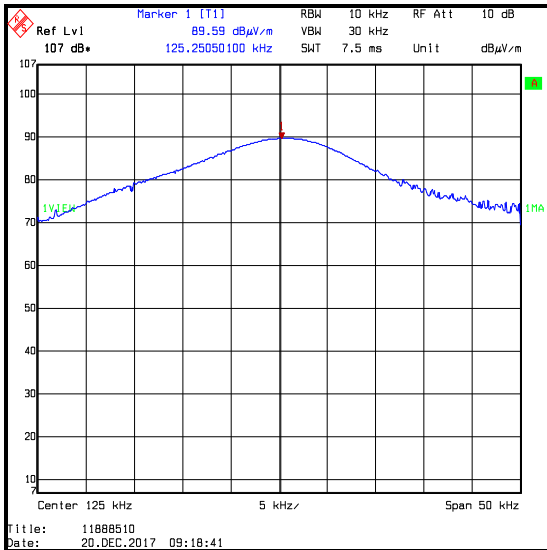

125 kHz reference unit signal at 3 metres on an open field test site on 20 December 2017

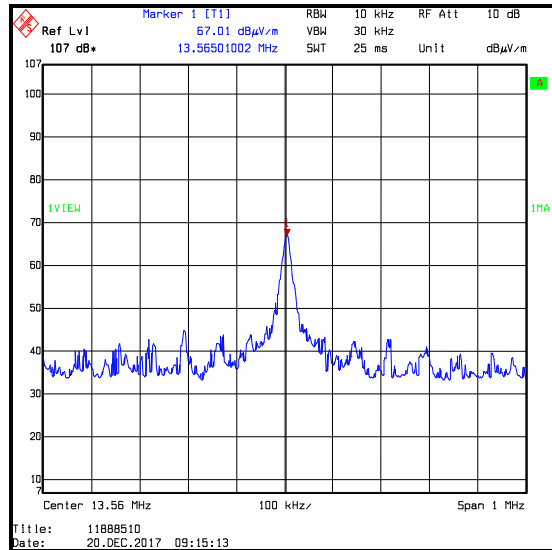

13.56 MHz reference unit signal at 3 metres on an open field test site on 20 December 2017

Note(s):

1. The above plots show comparable measurements of reference units on an open field test site and in a semi-anechoic chamber at spot frequencies.

Background scans of the open field test site

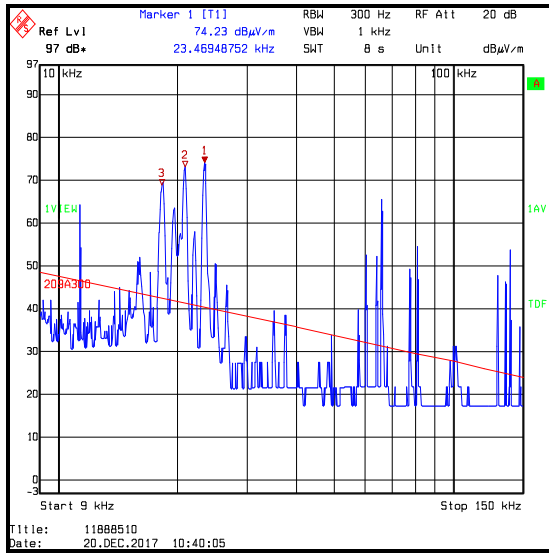

**Frequency range: 9 kHz to 150 kHz
Average detector / background scan**

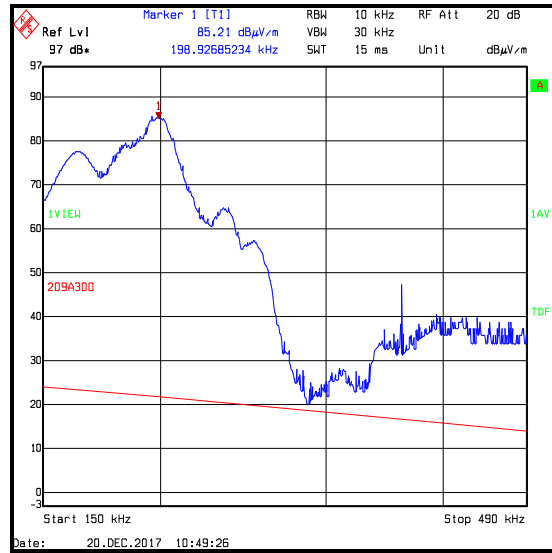

**Frequency range: 150 kHz to 490 kHz
Average detector / background scan**

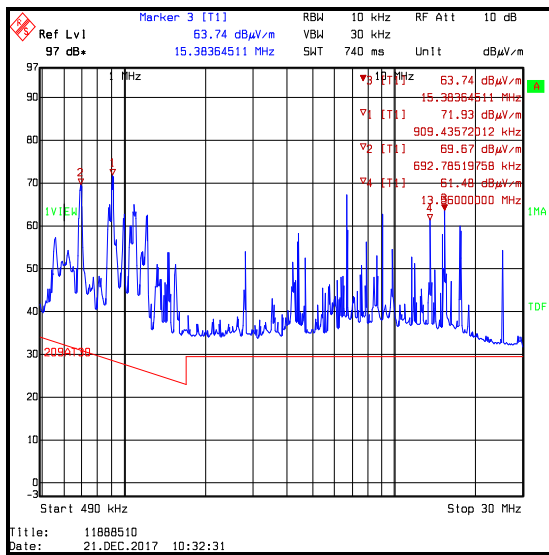

**Frequency range: 490 kHz to 30 MHz
Peak detector / background scan**

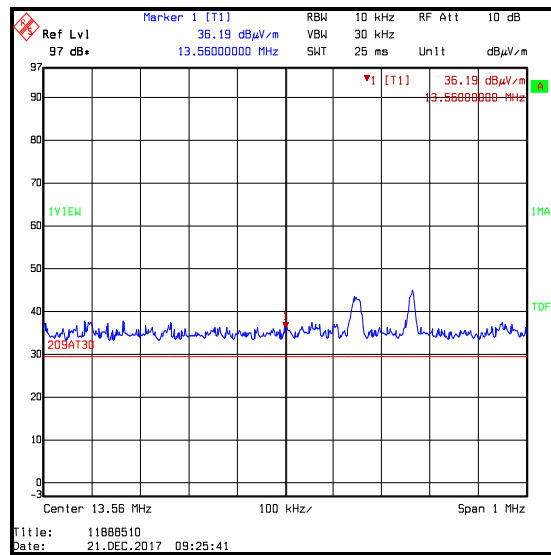

**Frequency range: 13.06 MHz to 14.06 MHz
/ background scan of the open field test site**

Note(s):

1. The above plots are background scans of the open field test site. The EUT and generator (when used) were turned off when the background scans were performed.

--- END OF REPORT ---