

## RADIO TEST REPORT

**Report Reference No.** ..... : POCE11073026RF

Compiled by (+ signature) ..... Jomy Qiu

*Jomy qiu*

Approved by (+ signature) ..... Ada Li

*Ada Li*

Date of issue ..... : 2011-08-11

Total number of pages ..... 81

**Applicant's name** ..... : ALFA NETWORK Inc.

Address ..... : 4F-1 No.106, Rueiguang Rd., Neihu Distric, Taipei City 114

**Manufacture's Name** ..... : ALFA NETWORK Inc.

Address ..... : 4F-1 No.106, Rueiguang Rd., Neihu Distric, Taipei City 114

**Factory's Name** ..... : ALFA NETWORK Inc.

Address ..... : 4F-1 No.106, Rueiguang Rd., Neihu Distric, Taipei City 114

**Test specification:**

Standard ..... : FCC Part 15.247

Test procedure ..... : ANSI C63.4 : 2003

Non-standard test method ..... : N/A

**Test item description**

Product name ..... : Outdoor Long Range USB CPE with N male connector

Trademark ..... : /

Model and/or type reference : TUBE-U(N)

Rating(s) ..... : DC 5V by USB

**Possible test case verdicts:**

- test case does not apply to the test object N/A  
.....:
- test object does meet the requirement.: P (Pass)
- test object does not meet the requirement .....: F (Fail)

**Testing** .....

Date of receipt of test item .....: 2011-08-2  
Date (s) of performance of tests .....: 2011-08-2~2011-08-10

**General remarks:**

**The test results presented in this report relate only to the object tested.**

**The results contained in this report reflect the results for this particular model and serial number. It is the responsibility of the manufacturer to ensure that all production models meet the intent of the requirements detailed within this report.**

**This report would be invalid test report without all the signatures of testing technician and approver.**

**This report shall not be reproduced, except in full, without the written approval of the Issuing testing laboratory.**

**Table of Contents**

	<b>Page</b>
<b>1 . SUMMARY OF TEST RESULTS</b>	<b>5</b>
1.1 TEST FACILITY	6
1.2 MEASUREMENT UNCERTAINTY	6
<b>2 . GENERAL INFORMATION</b>	<b>7</b>
2.1 GENERAL DESCRIPTION OF EUT	7
2.2 DESCRIPTION OF TEST MODES	9
2.3 TABLE OF PARAMETERS OF TEXT SOFTWARE SETTING	9
2.4 BLOCK DIGRAM SHOWING THE CONFIGURATION OF SYSTEM TESTED	10
2.5 DESCRIPTION OF SUPPORT UNITS(CONDUCTED MODE)	11
2.6 EQUIPMENTS LIST FOR ALL TEST ITEMS	12
<b>3 . EMC EMISSION TEST</b>	<b>13</b>
3.1 CONDUCTED EMISSION MEASUREMENT	13
3.1.1 POWER LINE CONDUCTED EMISSION LIMITS	13
3.1.2 TEST PROCEDURE	14
3.1.3 DEVIATION FROM TEST STANDARD	14
3.1.4 TEST SETUP	14
3.1.5 EUT OPERATING CONDITIONS	15
3.1.6 TEST RESULTS	16
3.2 RADIATED EMISSION MEASUREMENT	18
3.2.1 RADIATED EMISSION LIMITS	18
3.2.2 TEST PROCEDURE	19
3.2.3 DEVIATION FROM TEST STANDARD	19
3.2.4 TEST SETUP	20
3.2.5 EUT OPERATING CONDITIONS	20
3.2.6 TEST RESULTS (BETWEEN 9KHZ – 1000 MHZ)	21
3.2.7 TEST RESULTS (ABOVE 1000 MHZ)	23
<b>4 . POWER SPECTRAL DENSITY TEST</b>	<b>45</b>
4.1 APPLIED PROCEDURES / LIMIT	45
4.1.1 TEST PROCEDURE	45
4.1.2 DEVIATION FROM STANDARD	45
4.1.3 TEST SETUP	45
4.1.4 EUT OPERATION CONDITIONS	45
4.1.5 TEST RESULTS	46
<b>5 . BANDWIDTH TEST</b>	<b>54</b>
5.1 APPLIED PROCEDURES / LIMIT	54
5.1.1 TEST PROCEDURE	54

**Table of Contents**

	<b>Page</b>
5.1.2 DEVIATION FROM STANDARD	54
5.1.3 TEST SETUP	54
5.1.4 EUT OPERATION CONDITIONS	54
5.1.5 TEST RESULTS	55
<b>6 . PEAK OUTPUT POWER TEST</b>	<b>63</b>
6.1 APPLIED PROCEDURES / LIMIT	63
6.1.1 TEST PROCEDURE	63
6.1.2 DEVIATION FROM STANDARD	63
6.1.3 TEST SETUP	63
6.1.4 EUT OPERATION CONDITIONS	63
6.1.5 TEST RESULTS	64
<b>7 . ANTENNA CONDUCTED SPURIOUS EMISSION</b>	<b>66</b>
7.1 APPLIED PROCEDURES / LIMIT	66
7.1.1 TEST PROCEDURE	66
7.1.2 DEVIATION FROM STANDARD	66
7.1.3 TEST SETUP	67
7.1.4 EUT OPERATION CONDITIONS	67
7.1.5 TEST RESULTS	68
<b>8 . RF EXPOSURE TEST</b>	<b>76</b>
8.1 APPLIED PROCEDURES / LIMIT	76
8.1.1 MPE CALCULATION METHOD	77
8.1.2 TEST RESULTS	78
<b>9 . EUT TEST PHOTO</b>	<b>80</b>

## 1. SUMMARY OF TEST RESULTS

Test procedures according to the technical standards:

<b>FCC Part15 (15.247) , Subpart C</b>			
Standard Section	Test Item	Judgment	Remark
15.207	Conducted Emission	PASS	
15.247 (c)	Antenna conducted Spurious Emission	PASS	
15.247 (a)(2)	6dB Bandwidth	PASS	
15.247 (b)	Peak Output Power	PASS	
15.247 (c)	Radiated Spurious Emission	PASS	
15.247 (d)	Power Spectral Density	PASS	
15.203	Antenna Requirement	PASS	
1.1307 1.1310 2.1091 2.1093	RF Exposure Compliance	PASS	

**NOTE:**

(1) "N/A" denotes test is not applicable in this Test Report

## 1.1 TEST FACILITY

NTEK Testing Technology Co., Ltd.

Add. : 1/F, Building E, Fenda Science Park, Sanwei Community, Xixiang Street, Bao'an District, Shenzhen P.R. China

## 1.2 MEASUREMENT UNCERTAINTY

The reported uncertainty of measurement  $y \pm U$ , where expanded uncertainty  $U$  is based on a standard uncertainty multiplied by a coverage factor of  $k=2$ , providing a level of confidence of approximately **95 %**.

A. Conducted Measurement :

Test Site	Method	Measurement Frequency Range	U , (dB)	NOTE
C01	ANSI	150 KHz ~ 30MHz	1.94	

B. Radiated Measurement :

No.	Item	Uncertainty
1	Conducted Emission Test	$\pm 1.38\text{dB}$
2	Radiated Emission Test	$\pm 3.17\text{dB}$
3	RF power,conducted	$\pm 0.16\text{dB}$
4	Spurious emissions,conducted	$\pm 0.21\text{dB}$
5	All emissions,radiated(<1G)	$\pm 4.68\text{dB}$
6	All emissions,radiated(>1G)	$\pm 4.89\text{dB}$

## 2. GENERAL INFORMATION

### 2.1 GENERAL DESCRIPTION OF EUT

Equipment	Outdoor Long Range USB CPE with N male connector	
Trade Name	ALFA	
Model Name	TUBE-U(N)	
OEM Brand/Model Name	N/A	
Product Description	The EUT is a Dreampad	
	Operation Frequency:	802.11b: 2412~2462 MHz 802.11g: 2412~2462 MHz 802.11n(20MHzchannel): 2412~2462 MHz 802.11n(40MHzchannel): 2422~2452 MHz
	Modulation Type:	CCK/OFDM/DBPSK/DAPSK
	Bit Rate of Transmitter	802.11b:11/5.5/2/1 Mbps 802.11g:54/48/36/24/18/12/9/6 Mbps 802.11n(20MHz):72 Mbps 802.11n(40MHz):150 Mbps
	Number Of Channel	11 CH, Please see Note 2.
	Antenna Designation:	Please see Note 3.
	Antenna Gain(Peak)	Please see Note 3.
	Output Power:	802.11b: 26.71 dBm (Max.) 802.11g: 25.57dBm (Max.) 802.11n (20MHz):25.55dBm(Max) 802.11n (40MHz):25.99dBm(Max)
	Based on the application, features, or specification exhibited in User's Manual, the EUT is considered as an ITE/Computing Device. More details of EUT technical specification, please refer to the User's Manual.	
	Channel List	Please refer to the Note 2.
Power Source	DC 5V from PC	
Power Rating	DC 5V(USB)	
Connecting I/O Port(s)	Please refer to the User's Manual	
Products Covered	N/A	
EUT Modification(s)	N/A	

Note

:

1. For a more detailed features description, please refer to the manufacturer's specifications or the User's Manual.

2.

Channel List							
Channel	Frequency (MHz)	Channel	Frequency (MHz)	Channel	Frequency (MHz)	Channel	Frequency (MHz)
01	2412	04	2427	07	2442	10	2457
02	2417	05	2432	08	2447	11	2462
03	2422	06	2437	09	2452		

3.

Table for Filed Antenna

Ant	Brand	Model Name	Antenna Type	Connector	Gain (dBi)	NOTE
1	N/A	N/A	External Omni Antenna	Reserve N-type	1.1	N/A



## 2.2 DESCRIPTION OF TEST MODES

To investigate the maximum EMI emission characteristics generates from EUT, the test system was pre-scanning tested base on the consideration of following EUT operation mode or test configuration mode which possible have effect on EMI emission level. Each of these EUT operation mode(s) or test configuration mode(s) mentioned above was evaluated respectively.

Pretest Mode	Description
Mode 1	802.11b CH1/ CH6/ CH11
Mode 2	802.11g CH1/ CH6/ CH11
Mode 3	802.11n CH1/ CH6/ CH11
Mode 4	802.11n CH2/ CH6/ CH10

For Conducted Emission	
Final Test Mode	Description
TX	NORMAL LINK

For Radiated Emission	
Final Test Mode	Description
Mode 1	802.11b CH1/ CH6/ CH11
Mode 2	802.11g CH1/ CH6/ CH11
Mode 3	802.11n CH1/ CH6/ CH11
Mode 4	802.11n CH2/ CH6/ CH10

Note:

(1) The measurements are performed at the highest, middle, lowest available channels.

## 2.3 TABLE OF PARAMETERS OF TEXT SOFTWARE SETTING

During testing channel & power controlling software provided by the customer was used to control the operating channel as well as the output power level. The RF output power selection is for the setting of RF output power expected by the customer and is going to be fixed on the firmware of the final end product power parameters of WLAN

Test software Version	Test program: Ralink RT3x7x_V1.5.2.0		
Frequency	2412 MHz	2437 MHz	2462 MHz
802.11b	42	42	42
802.11g	45	45	45
802.11n	45	45	45

## 2.4 BLOCK DIGRAM SHOWING THE CONFIGURATION OF SYSTEM TESTED

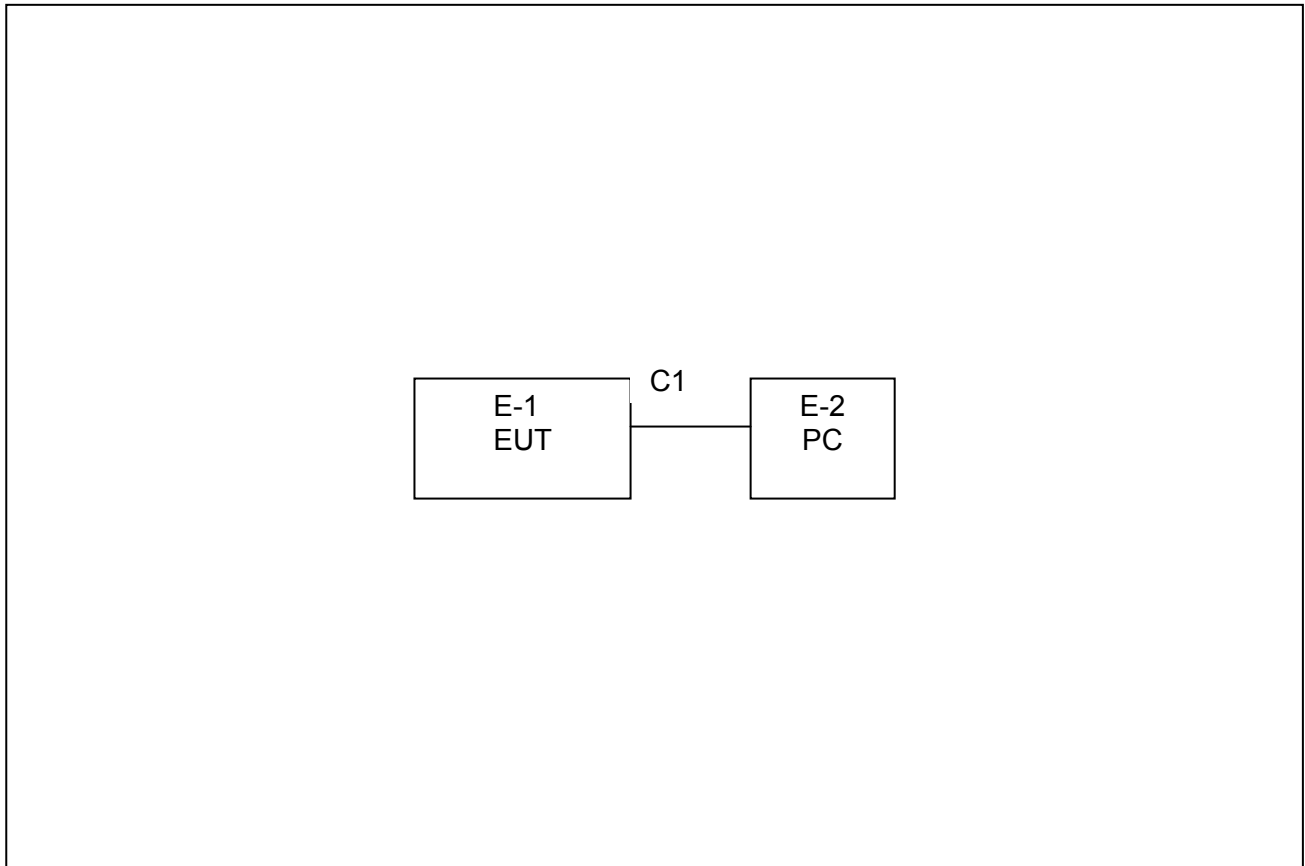

## 2.5 DESCRIPTION OF SUPPORT UNITS(CONDUCTED MODE)

The EUT has been tested as an independent unit together with other necessary accessories or support units. The following support units or accessories were used to form a representative test configuration during the tests.

Item	Equipment	Mfr/Brand	Model/Type No.	FCC ID	Series No.	Note
E-1	Outdoor Long Range USB CPE with N male connector	ALFA	TUBE-U(N)	UQ2TUBEUN	N/A	EUT
E-2	Notebook computer	IBM	2366	N/A	N/A	AU

Item	Shielded Type	Ferrite Core	Length	Note
C1	NO	NO	5M	

Note:

- (1) The support equipment was authorized by Declaration of Confirmation.
- (2) For detachable type I/O cable should be specified the length in cm in 『Length』 column.

## 2.6 EQUIPMENTS LIST FOR ALL TEST ITEMS

<b>Radiation Test Equipment:</b>					
No	Test Equipment	Manufacturer	Model No	Serial No	Cal. Due Date dd-mm-yy
1	Spectrum Analyzer	Agilent	E4407B	160400005	2012-4-24
2	Test Receiver	R&S	ESPI7	101318	2012-4-24
3	Bilog Antenna	TESEQ	CBL6111D	31216	2012-4-24
4	50Ω Coaxial Switch	Anritsu	MP59B	620026441 6	2012-4-24
5	Spectrum Analyzer	ADVANTEST	R3182	150900201	2012-4-24
6	Low Noise Pre Amplifier	Tsj	MLA-0120-A02-34	2648A0473 8	2012-4-24
7	Broadband Horn Antenna	SCHWARZBEC K	BBHA9120D	451	2012-4-24
8	Loop Antenna	ARA	PLA-1030/B	1029	2012-3-19

<b>Conduction Test equipment</b>					
No	Test Equipment	Manufacturer	Model No	Serial No	Cal. Due Date dd-mm-yy
1**	Test Receiver	R&S	ESCI	101160	2012-4-24
2	LISN	R&S	ENV216	101313	2012-4-24
3	LISN	Kyoritsu	KNW-407	8-1789-3	2012-4-24
4**	50Ω Coaxial Switch	Anritsu	MP59B	620026441 7	2012-4-24
5	Passive Voltage Probe	R&S	ESH2-Z3	100196	2012-4-24
6	Absorbing clamp	R&S	MDS-21	100423	2012-4-24

### 3. EMC EMISSION TEST

#### 3.1 CONDUCTED EMISSION MEASUREMENT

##### 3.1.1 POWER LINE CONDUCTED EMISSION Limits (Frequency Range 150KHz-30MHz)

FREQUENCY (MHz)	Class A (dBuV)		Class B (dBuV)		Standard
	Quasi-peak	Average	Quasi-peak	Average	
0.15 -0.5	79.00	66.00	66 - 56 *	56 - 46 *	CISPR
0.50 -5.0	73.00	60.00	56.00	46.00	CISPR
5.0 -30.0	73.00	60.00	60.00	50.00	CISPR

0.15 -0.5	79.00	66.00	66 - 56 *	56 - 46 *	FCC
0.50 -5.0	73.00	60.00	56.00	46.00	FCC
5.0 -30.0	73.00	60.00	60.00	50.00	FCC

Note:

- (1) The tighter limit applies at the band edges.
- (2) The limit of " \* " marked band means the limitation decreases linearly with the logarithm of the frequency in the range.

The following table is the setting of the receiver

Receiver Parameters	Setting
Attenuation	10 dB
Start Frequency	0.15 MHz
Stop Frequency	30 MHz
IF Bandwidth	9 kHz

### 3.1.2 TEST PROCEDURE

- a. The EUT was placed 0.4 meters from the horizontal ground plane with EUT being connected to the power mains through a line impedance stabilization network (LISN). All other support equipments powered from additional LISN(s). The LISN provide 50 Ohm/ 50uH of coupling impedance for the measuring instrument.
- b. Interconnecting cables that hang closer than 40 cm to the ground plane shall be folded back and forth in the center forming a bundle 30 to 40 cm long.
- c. I/O cables that are not connected to a peripheral shall be bundled in the center. The end of the cable may be terminated, if required, using the correct terminating impedance. The overall length shall not exceed 1 m.
- d. LISN at least 80 cm from nearest part of EUT chassis.
- e. For the actual test configuration, please refer to the related Item –EUT Test Photos.

### 3.1.3 DEVIATION FROM TEST STANDARD

No deviation

### 3.1.4 TEST SETUP

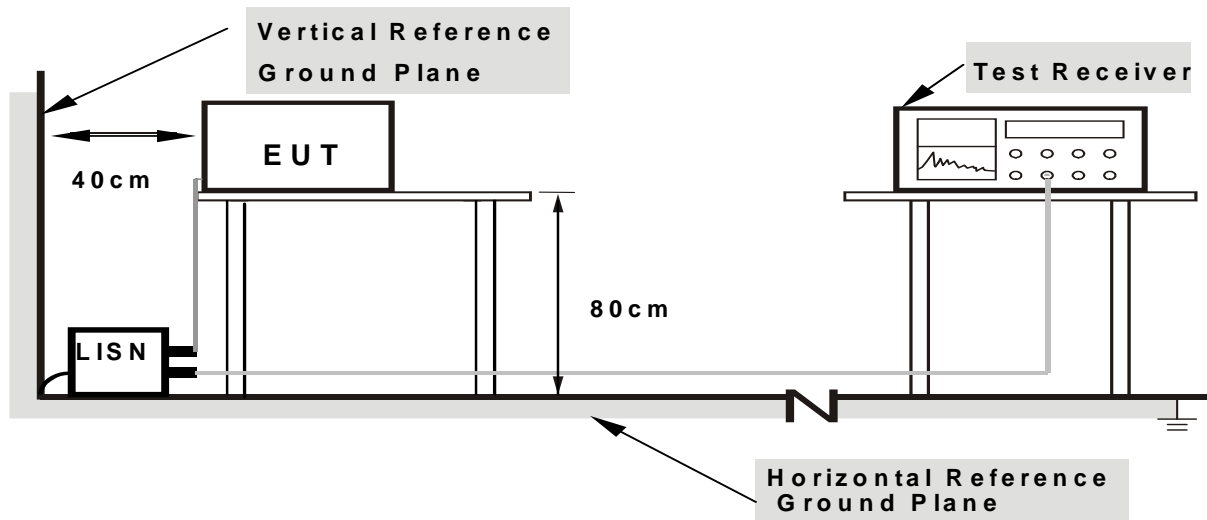

**Note: 1.Support units were connected to second LISN.**

**2.Both of LISNs (AMN) are 80 cm from EUT and at least 80 from other units and other metal planes**

### **3.1.5 EUT OPERATING CONDITIONS**

The EUT was configured for testing in a typical fashion (as a customer would normally use it). The EUT has been programmed to continuously transmit during test. This operating condition was tested and used to collect the included data.

### 3.1.6 TEST RESULTS

EUT :	Outdoor Long Range USB CPE with N male connector	Model Name. :	TUBE-U(N)
Temperature :	26 °C	Relative Humidity :	54%
Pressure :	1010hPa	Test Date :	2011-8-8
Test Mode :	Normal Link	Phase :	L
Test Voltage :	DC 5V From PC		

Frequency (MHz)	Factor (dB)	Meter Reading (dBμV)		Emission Level (dBμV)		Limits (dBμV)		Margin (dB)	
		QP	Average	QP	Average	QP	Average	QP	Average
0.1620	11.68	36.19	23.95	47.87	35.63	65.36	55.36	-17.49	-19.73
0.2060	11.10	34.90	25.51	46.00	36.61	63.37	53.53	-17.37	-16.92
0.3140	10.71	33.97	24.55	44.68	35.26	59.86	49.86	-15.18	-14.60
*0.4260	10.49	34.10	26.61	44.59	37.10	57.33	47.33	-12.74	-10.23
0.6380	10.28	29.35	22.10	39.63	32.38	56.00	46.00	-16.37	-13.62
8.8220	10.26	28.43	23.53	38.69	33.79	60.00	50.00	-21.31	-16.21

Remark:

1. All readings are Quasi-Peak and Average values.
2. Factor = Insertion Loss + Cable Loss.
3. '\*' means the worst case

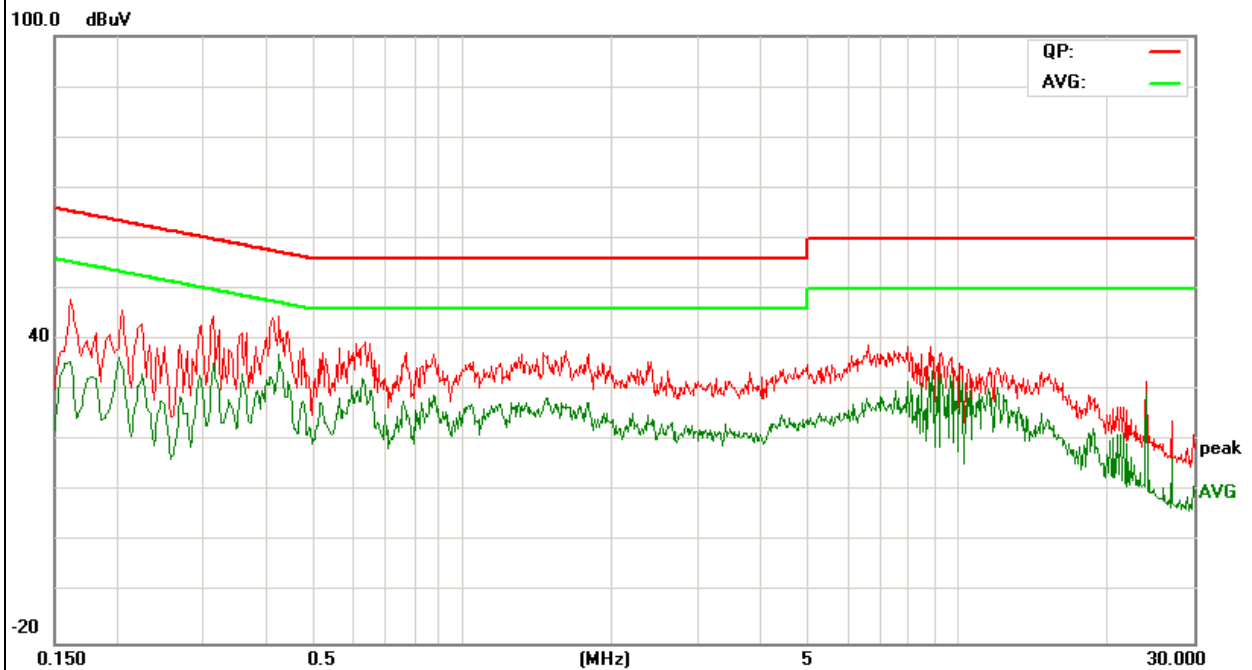



EUT :	Outdoor Long Range USB CPE with N male connector	Model Name. :	TUBE-U(N)
Temperature :	26 °C	Relative Humidity :	54%
Pressure :	1010hPa	Test Date :	2011-8-5
Test Mode :	Normal Link	Phase :	N
Test Voltage :	DC 5V From PC		

Frequency (MHz)	Factor (dB)	Meter Reading (dBμV)		Emission Level (dBμV)		Limits (dBμV)		Margin (dB)	
		QP	Average	QP	Average	QP	Average	QP	Average
0.1620	11.68	36.19	23.95	47.87	35.63	65.36	55.36	-17.49	-19.73
0.2060	11.10	34.90	25.51	46.00	36.61	63.37	53.53	-17.37	-16.92
0.3140	10.71	33.97	24.55	44.68	35.26	59.86	49.86	-15.18	-14.60
*0.4260	10.49	34.10	26.61	44.59	37.10	57.33	47.33	-12.74	-10.23
0.6380	10.28	29.35	22.10	39.63	32.38	56.00	46.00	-16.37	-13.62
8.8220	10.26	28.43	23.53	38.69	33.79	60.00	50.00	-21.31	-16.21

Remark:

1. All readings are Quasi-Peak and Average values.
2. Factor = Insertion Loss + Cable Loss.
3. '\*' means the worst case

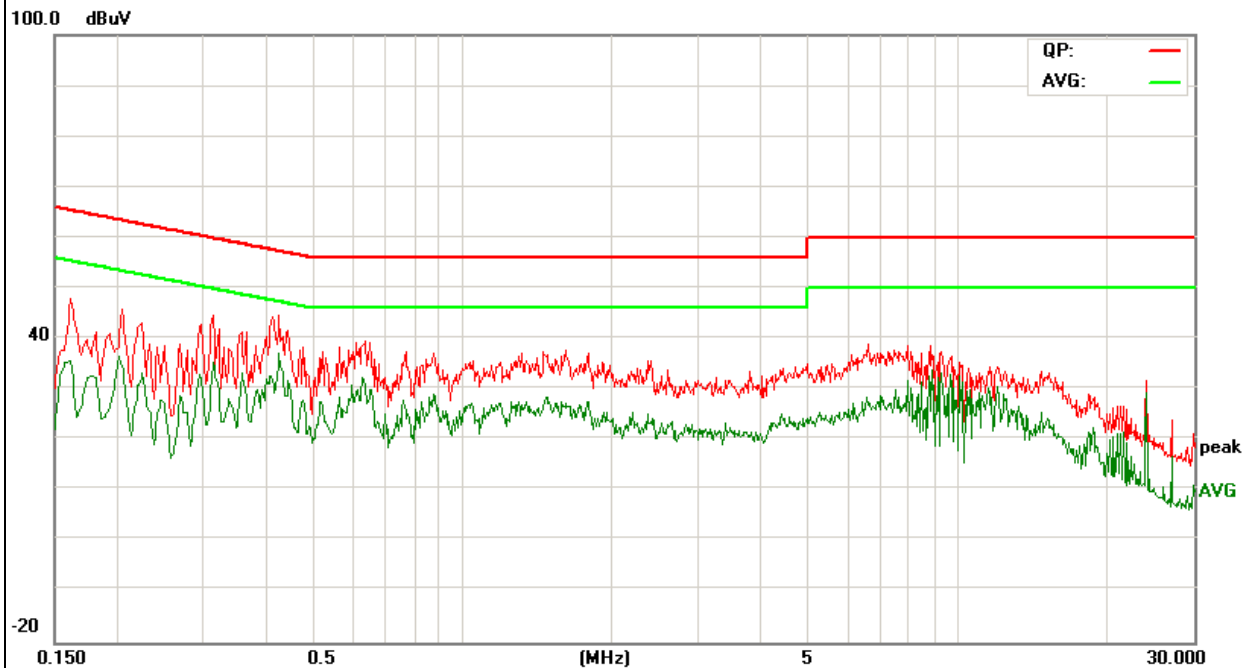

### 3.2 RADIATED EMISSION MEASUREMENT

#### 3.2.1 RADIATED EMISSION LIMITS (Frequency Range 9kHz-1000MHz)

20dBc in any 100 kHz bandwidth outside the operating frequency band. In case the emission fall within the restricted band specified on 15.205(a), then the 15.209(a) limit in the table below has to be followed.

Frequencies (MHz)	Field Strength (micorvolts/meter)	Measurement Distance (meters)
0.009~0.490	2400/F(KHz)	300
0.490~1.705	24000/F(KHz)	30
1.705~30.0	30	30
30~88	100	3
88~216	150	3
216~960	200	3
Above 960	500	3

#### LIMITS OF RADIATED EMISSION MEASUREMENT (Above 1000MHz)

FREQUENCY (MHz)	Class A (dBuV/m) (at 3M)		Class B (dBuV/m) (at 3M)	
	PEAK	AVERAGE	PEAK	AVERAGE
Above 1000	80	60	74	54

Notes:

- (1) The limit for radiated test was performed according to FCC PART 15C.
- (2) The tighter limit applies at the band edges.
- (3) Emission level (dBuV/m)=20log Emission level (uV/m).

Spectrum Parameter	Setting
Attenuation	Auto
Start Frequency	1000 MHz
Stop Frequency	10th carrier harmonic
RB / VB (emission in restricted band)	1 MHz / 1 MHz for Peak, 1 MHz / 10Hz for Average

Receiver Parameter	Setting
Attenuation	Auto
Start ~ Stop Frequency	9kHz~150kHz / RB 200Hz for QP
Start ~ Stop Frequency	150kHz~30MHz / RB 9kHz for QP
Start ~ Stop Frequency	30MHz~1000MHz / RB 120kHz for QP

### **3.2.2 TEST PROCEDURE**

- a. The measuring distance of at 3 m shall be used for measurements at frequency up to 1GHz. For frequencies above 1GHz, any suitable measuring distance may be used.
- b. The EUT was placed on the top of a rotating table 0.8 meters above the ground at a 3 meter open area test site. The table was rotated 360 degrees to determine the position of the highest radiation.
- c. The height of the equipment or of the substitution antenna shall be 0.8 m; the height of the test antenna shall vary between 1 m to 4 m. Both horizontal and vertical polarizations of the antenna are set to make the measurement.
- d. The initial step in collecting conducted emission data is a spectrum analyzer peak detector mode pre-scanning the measurement frequency range. Significant peaks are then marked and then Quasi Peak detector mode re-measured.
- e. If the Peak Mode measured value compliance with and lower than Quasi Peak Mode Limit, the EUT shall be deemed to meet QP Limits and then no additional QP Mode measurement performed.
- f. For the actual test configuration, please refer to the related Item –EUT Test Photos.

### **3.2.3 DEVIATION FROM TEST STANDARD**

No deviation

### 3.2.4 TEST SETUP

(A) Radiated Emission Test Set-Up, Frequency Below 1000MHz

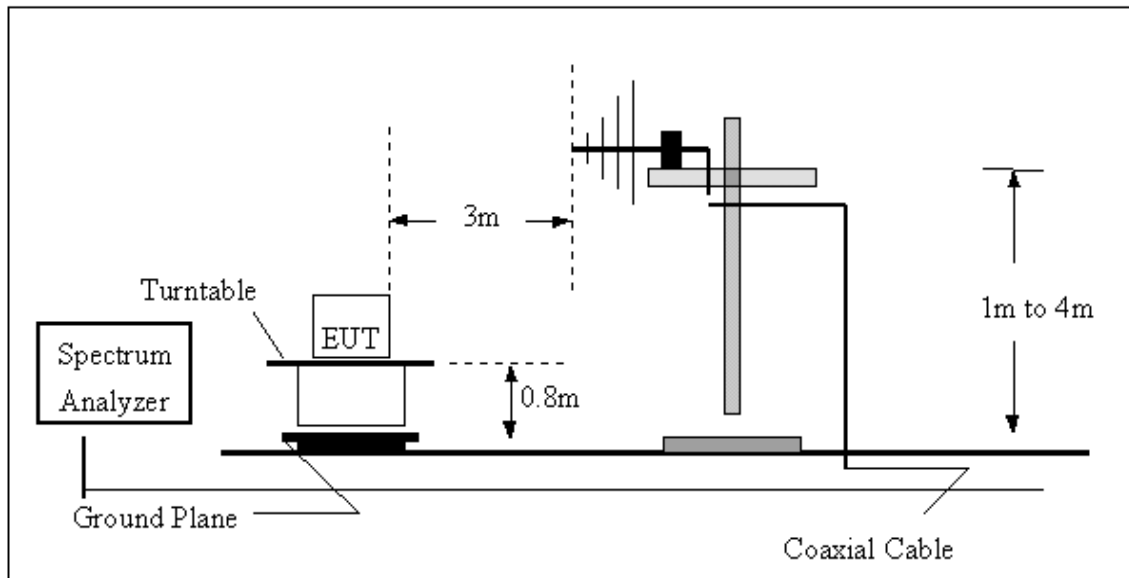

(B) Radiated Emission Test Set-Up Frequency Above 1 GHz

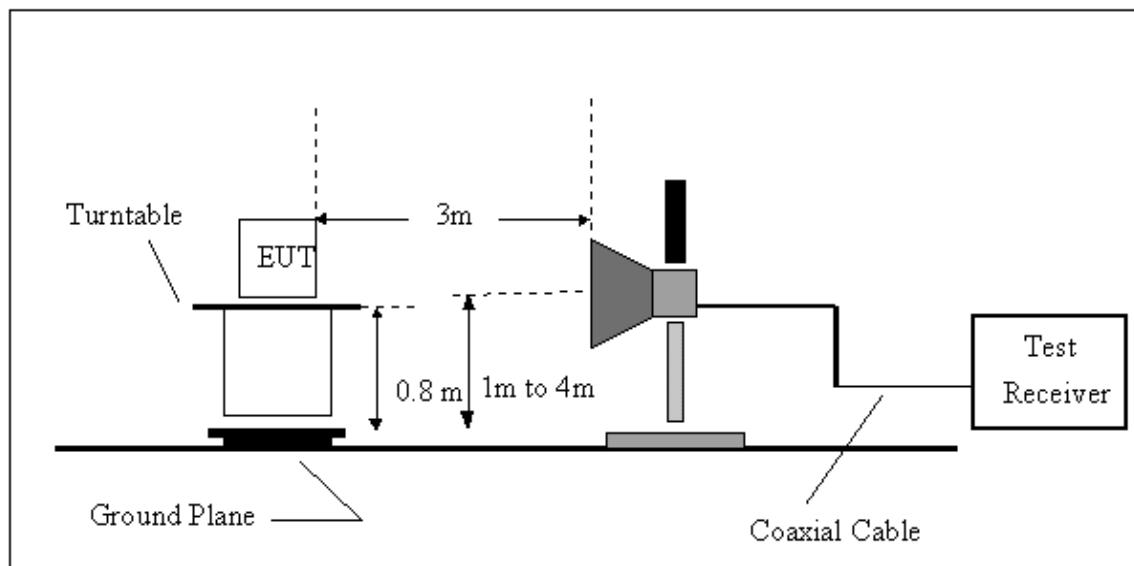

### 3.2.5 EUT OPERATING CONDITIONS

The EUT tested system was configured as the statements of 4.1.6 Unless otherwise a special operating condition is specified in the follows during the testing.

### 3.2.6 TEST RESULTS (BETWEEN 9KHZ – 1000 MHZ)

EUT :	Outdoor Long Range USB CPE with N male connector	Model Name :	TUBE-U(N)
Temperature :	20 °C	Relative Humidity :	48%
Pressure :	1010 hPa	Test Voltage :	DC 5V from PC
Test Mode :	TX	Polarization :	Horizontal

Frequency (MHz)	Meter Reading (dBμV)	Factor (dB)	Emission Level (dBμV/m)	Limits (dBμV/m)	Margin (dB)	Detector Type
99.9000	32.10	0.75	32.85	43.50	-10.65	Quasi-Peak
123.6700	34.20	0.60	34.80	43.50	-8.70	Quasi-Peak
300.2100	30.10	1.57	31.67	46.00	-14.33	Quasi-Peak
512.1200	28.05	1.42	29.47	46.00	-16.57	Quasi-Peak

Remark:

1. Factor = Antenna Factor + Cable Loss – Pre-amplifier.

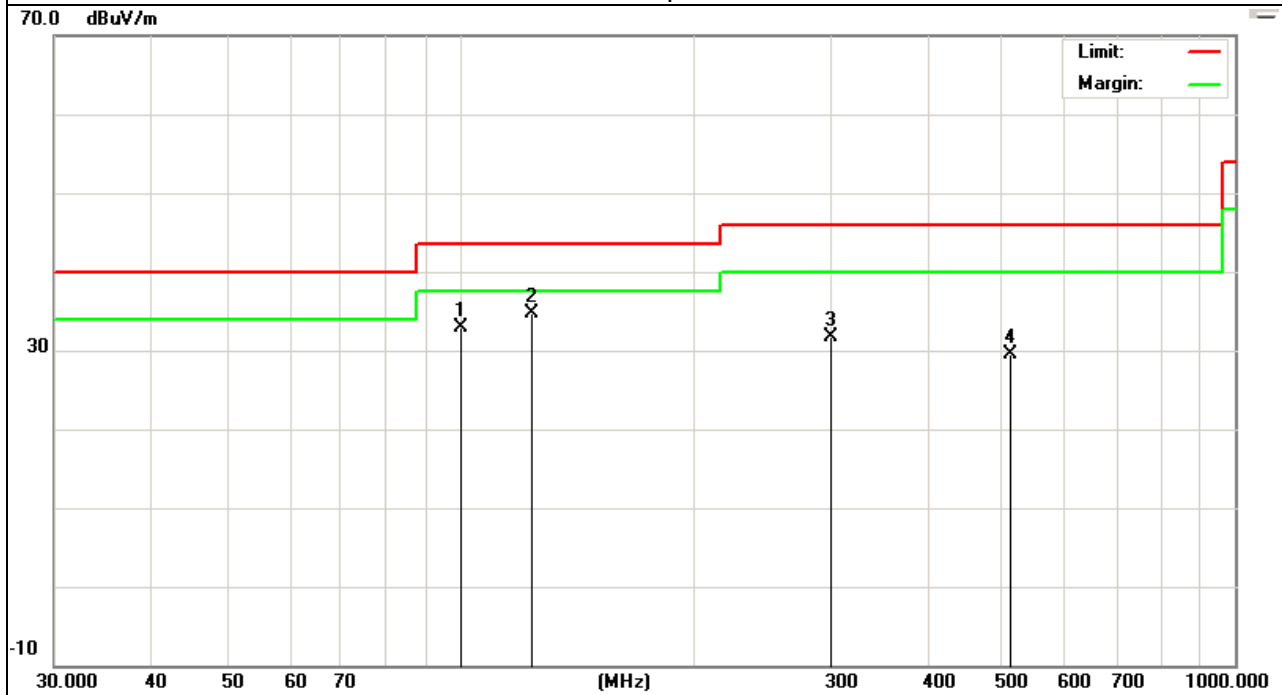

EUT :	Outdoor Long Range USB CPE with N male connector	Model Name :	TUBE-U(N)
Temperature :	20 °C	Relative Humidity :	48%
Pressure :	1010 hPa	Test Voltage :	DC 5V from PC
Test Mode :	TX	Polarization :	Vertical

Frequency (MHz)	Meter Reading (dBµV)	Factor (dB)	Emission Level (dBµV/m)	Limits (dBµV/m)	Margin (dB)	Detector Type
99.9000	30.21	0.75	30.96	43.50	-12.54	Quasi-Peak
123.6900	28.34	0.60	28.94	43.50	-14.56	Quasi-Peak
245.1700	25.26	1.10	26.36	46.00	-19.64	Quasi-Peak
300.2700	27.32	1.56	28.88	46.00	-17.12	Quasi-Peak

Remark:

1. Factor = Antenna Factor + Cable Loss – Pre-amplifier.

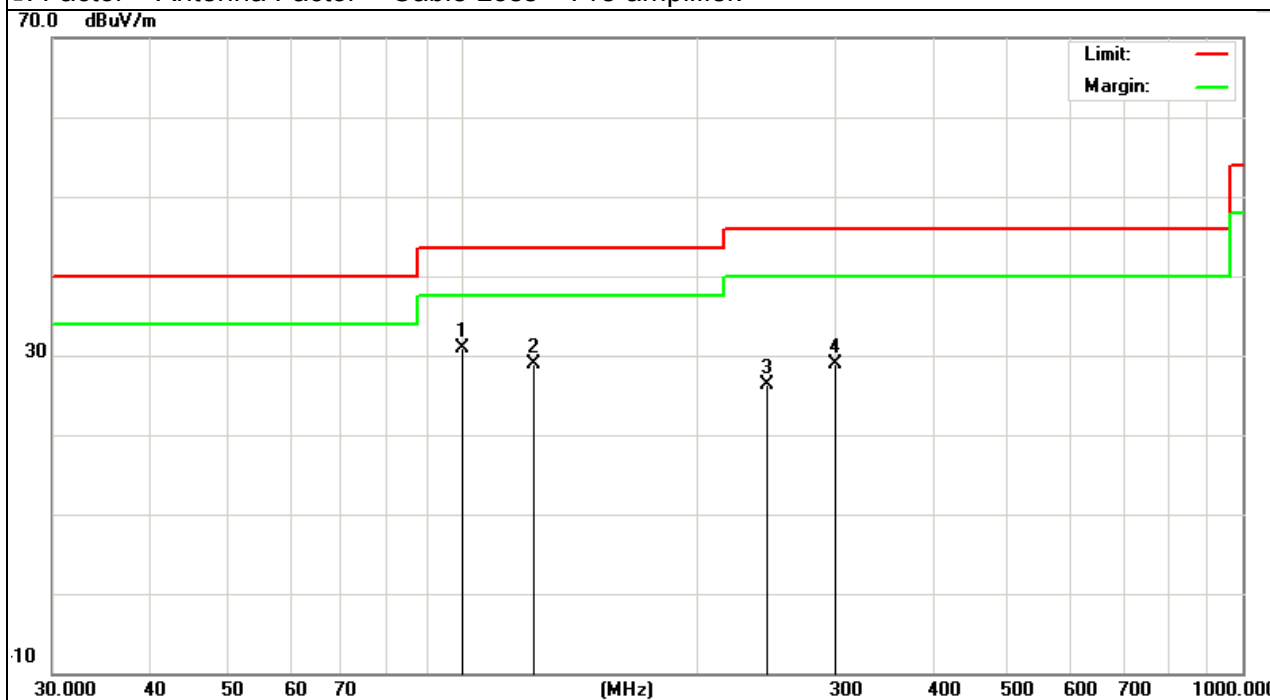

### 3.2.7 TEST RESULTS (ABOVE 1000 MHZ)

EUT :	Outdoor Long Range USB CPE with N male connector	Model Name :	TUBE-U(N)
Temperature :	20 °C	Relative Humidity :	48%
Pressure :	1010 hPa	Test Voltage :	DC 5V From PC
Test Mode :	CH1 (802.11b Mode)	Polarization :	Horizontal

Frequency (MHz)	Meter Reading (dBµV)	Factor (dB)	Emission Level (dBµV/m)	Limits (dBµV/m)	Margin (dB)	Detector Type
2400.00	19.31	32.65	51.96	74.00	-22.04	peak
2400.00	16.21	32.65	48.86	54.00	-5.14	AVG
4824.00	-1.21	44.04	42.83	74.00	-31.17	peak
4824.00	-3.41	44.04	40.63	54.00	-13.37	AVG
7236.00	0.21	48.03	48.24	74.00	-25.76	peak
7236.00	-3.21	48.03	44.91	54.00	-9.09	AVG

Remark:

- Factor = Antenna Factor + Cable Loss – Pre-amplifier.
- No emission detected above 18GHz

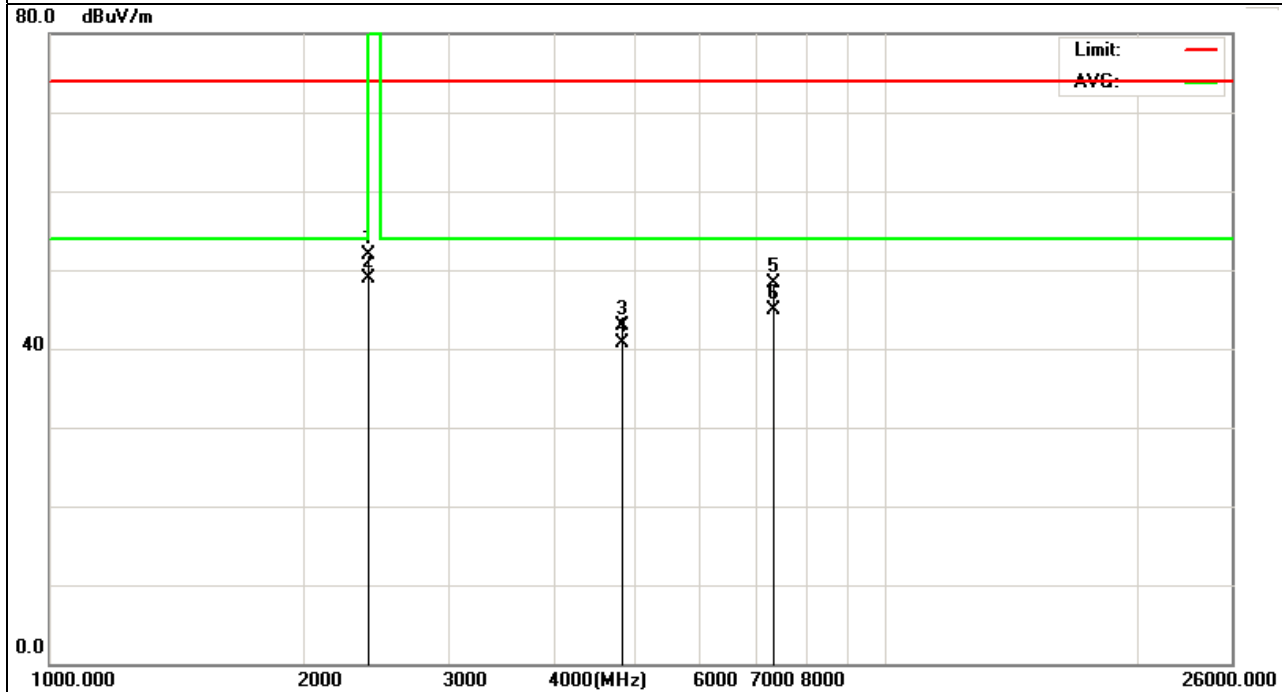

EUT :	Outdoor Long Range USB CPE with N male connector	Model Name :	TUBE-U(N)
Temperature :	20 °C	Relative Humidity :	48%
Pressure :	1010 hPa	Test Voltage :	DC5V from PC
Test Mode :	CH1 (802.11b Mode)	Polarization :	Vertical

Frequency (MHz)	Meter Reading (dBµV)	Factor (dB)	Emission Level (dBµV/m)	Limits (dBµV/m)	Margin (dB)	Detector Type
2400.00	15.21	32.65	47.86	74.00	-26.14	peak
2400.00	13.44	32.65	46.09	54.00	-7.91	AVG
4824.00	-3.44	44.04	40.60	74.00	-33.40	peak
4824.00	-7.44	44.04	36.60	54.00	-17.40	AVG
7326.00	-5.32	48.03	42.71	74.00	-31.29	peak
7326.00	-8.13	48.03	39.90	54.00	-14.10	AVG

Remark:

- Factor = Antenna Factor + Cable Loss – Pre-amplifier.
- No emission detected above 18GHz

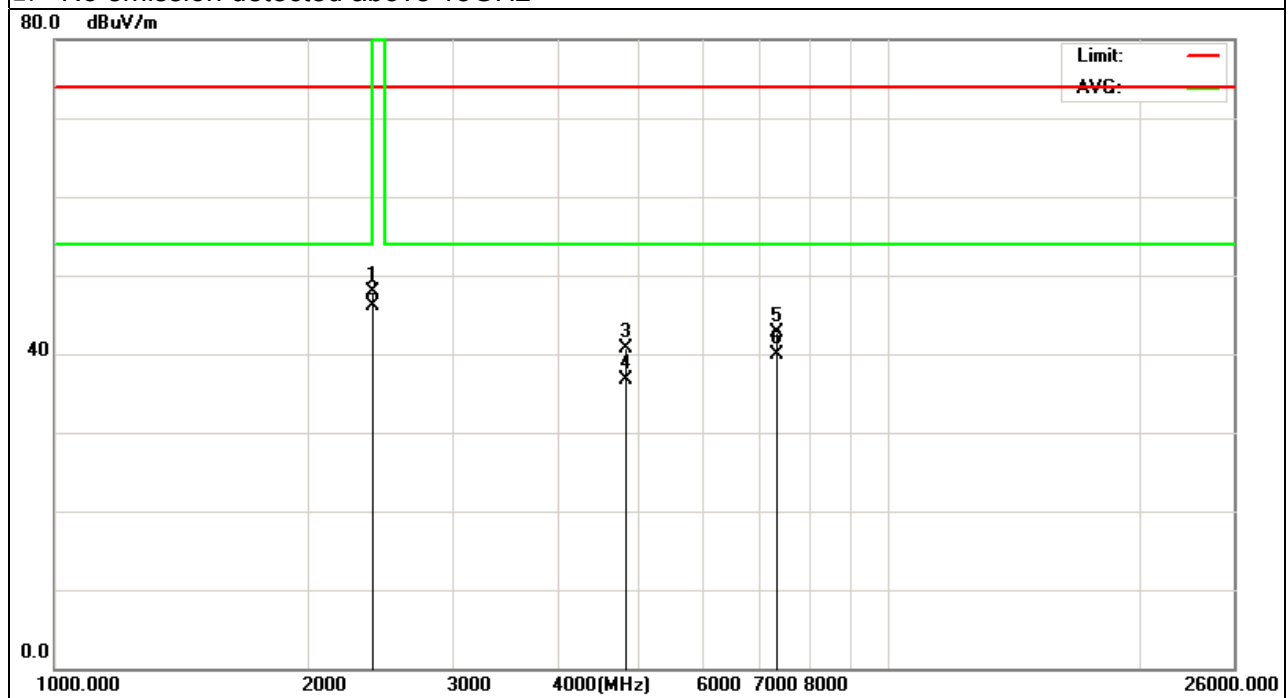



EUT :	Outdoor Long Range USB CPE with N male connector	Model Name :	TUBE-U(N)
Temperature :	20 °C	Relative Humidity :	48%
Pressure :	1010 hPa	Test Voltage :	DC5V from PC
Test Mode :	CH6 (802.11b Mode)	Polarization :	Horizontal

Frequency (MHz)	Meter Reading (dBμV)	Factor (dB)	Emission Level (dBμV/m)	Limits (dBμV/m)	Margin (dB)	Detector Type
4874.00	-0.13	44.07	43.94	74.00	-30.06	peak
4874.00	-4.25	44.07	39.82	54.00	-14.18	AVG
7311.00	-3.87	47.97	44.10	74.00	-29.90	peak
7311.00	-5.22	47.97	42.75	54.00	-11.25	AVG

Remark:

- Factor = Antenna Factor + Cable Loss – Pre-amplifier.
- No emission detected above 18GHz

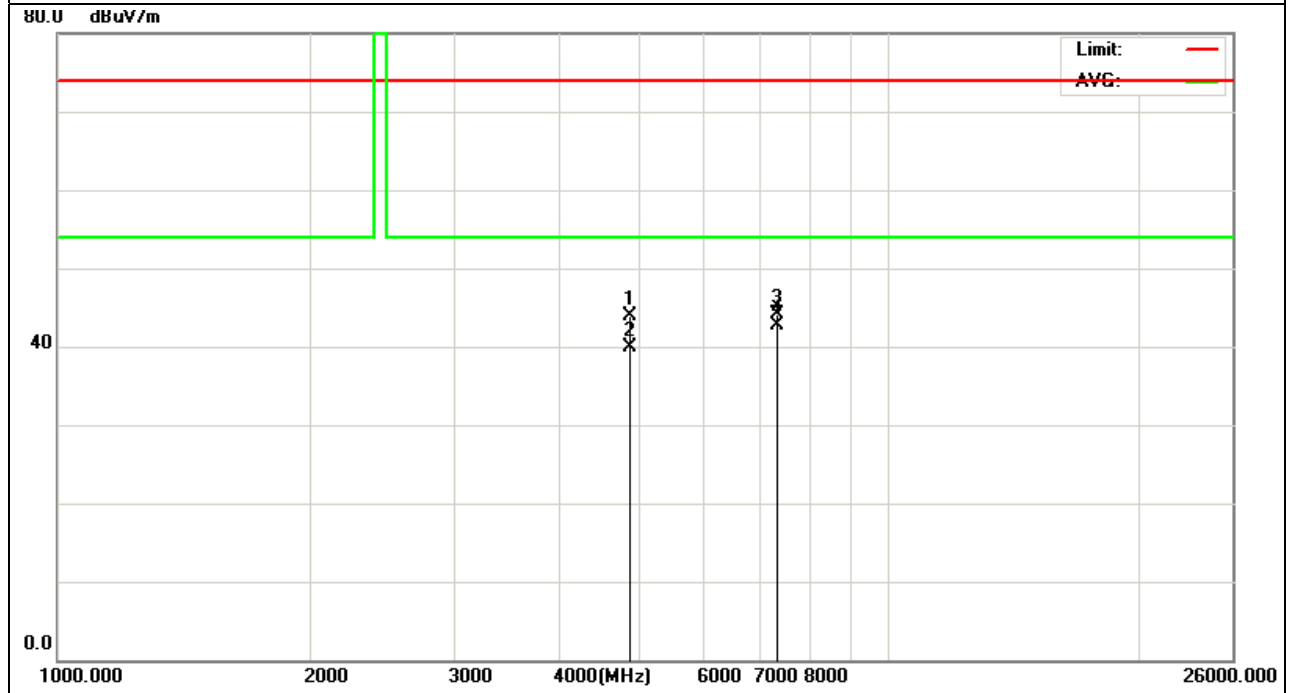

EUT :	Outdoor Long Range USB CPE with N male connector	Model Name :	TUBE-U(N)
Temperature :	20 °C	Relative Humidity :	48%
Pressure :	1010 hPa	Test Voltage :	DC5V from PC
Test Mode :	CH6 (802.11b Mode)	Polarization :	Vertical

Frequency (MHz)	Meter Reading (dBμV)	Factor (dB)	Emission Level (dBμV/m)	Limits (dBμV/m)	Margin (dB)	Detector Type
4874.00	1.32	44.07	45.39	74.00	-28.61	peak
4874.00	-3.54	44.07	40.53	54.00	-13.47	AVG
7311.00	0.54	47.97	48.51	74.00	-25.49	peak
7311.00	-4.31	47.97	43.66	54.00	-10.34	AVG

Remark:

- Factor = Antenna Factor + Cable Loss – Pre-amplifier.
- No emission detected above 18GHz

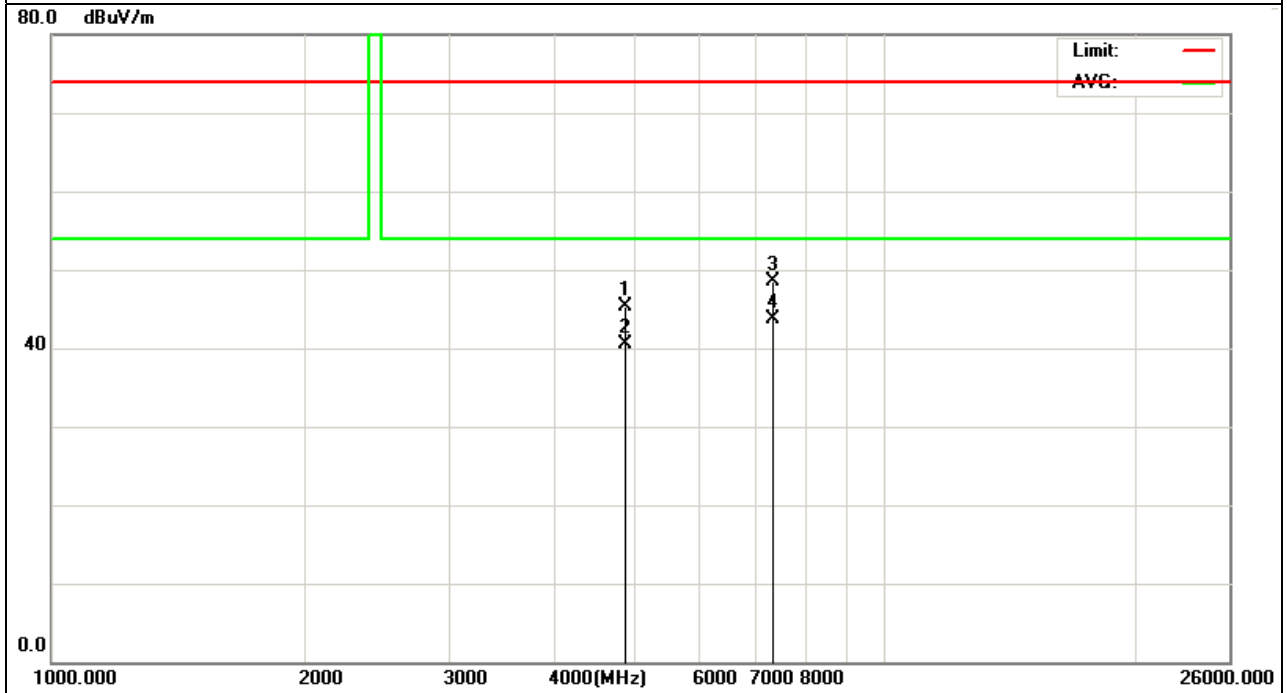

EUT :	Outdoor Long Range USB CPE with N male connector	Model Name :	TUBE-U(N)
Temperature :	20 °C	Relative Humidity :	48%
Pressure :	1010 hPa	Test Voltage :	DC5V from PC
Test Mode :	CH11 (802.11b Mode)	Polarization :	Horizontal

Frequency (MHz)	Meter Reading (dBµV)	Factor (dB)	Emission Level (dBµV/m)	Limits (dBµV/m)	Margin (dB)	Detector Type
2483.5	18.24	33.27	51.51	74.00	-22.49	peak
2483.5	14.33	33.27	47.60	54.00	-6.40	AVG
4924.00	1.31	44.10	45.41	74.00	-25.89	peak
4924.00	-5.31	44.10	38.79	54.00	-15.21	AVG
7386.00	-4.32	48.31	43.99	74.00	-30.01	peak
7386.00	-7.76	48.31	40.55	54.00	-13.45	AVG

Remark:

- Factor = Antenna Factor + Cable Loss – Pre-amplifier.
- No emission detected above 18GHz

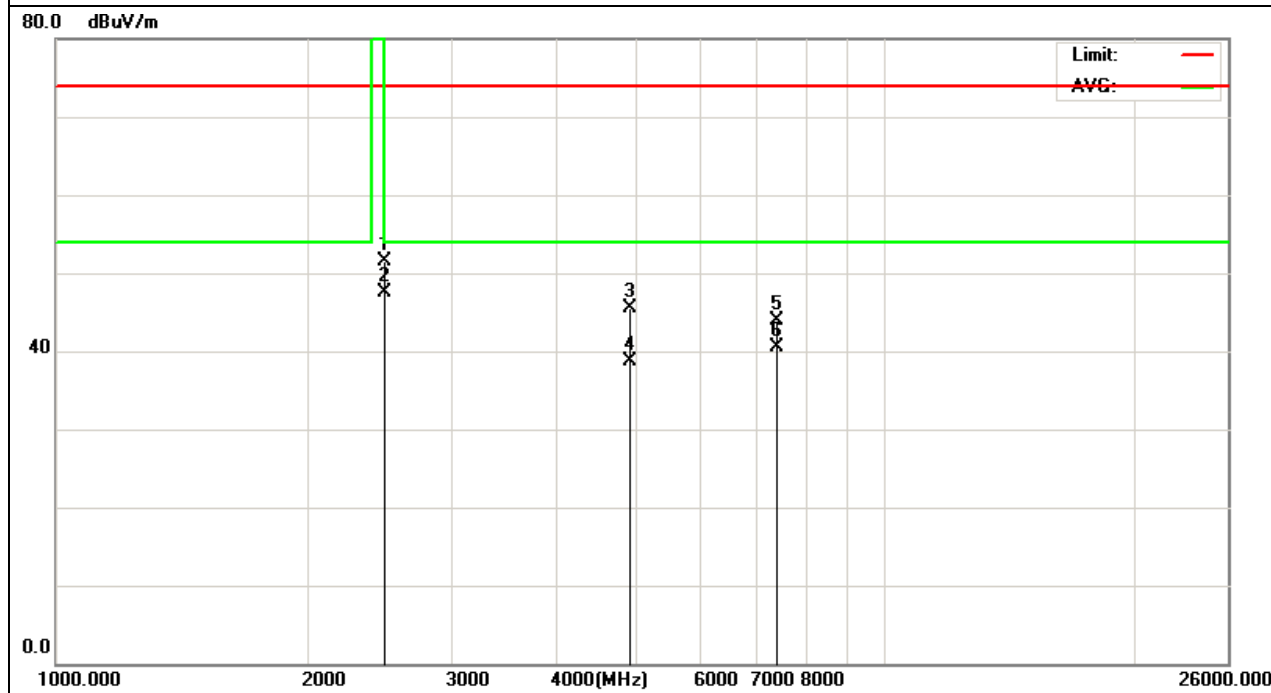

EUT :	Outdoor Long Range USB CPE with N male connector	Model Name :	TUBE-U(N)
Temperature :	20 °C	Relative Humidity :	48%
Pressure :	1010 hPa	Test Voltage :	DC5V from PC
Test Mode :	CH11 (802.11b Mode)	Polarization :	Vertical

Frequency (MHz)	Meter Reading (dBµV)	Factor (dB)	Emission Level (dBµV/m)	Limits (dBµV/m)	Margin (dB)	Detector Type
2483.5	52.11	4.36	56.47	74.00	-17.53	peak
2483.5	43.98	4.36	48.34	54.00	-5.66	AVG
4924.00	44.77	12.24	57.01	74.00	-16.99	peak
4924.00	35.51	12.24	47.75	54.00	-6.25	AVG
7386.00	35.58	18.50	54.08	74.00	-19.92	peak
7386.00	27.23	18.50	45.73	54.00	-8.27	AVG

Remark:

- Factor = Antenna Factor + Cable Loss – Pre-amplifier.
- No emission detected above 18GHz

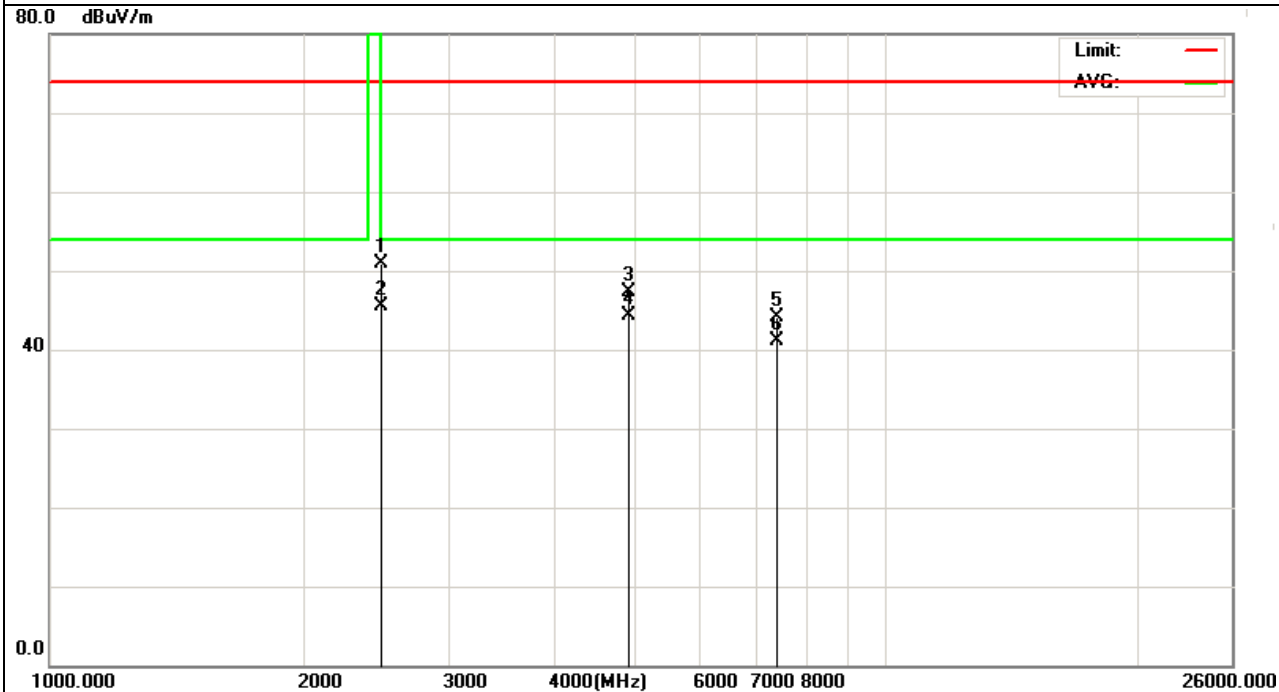

EUT :	Outdoor Long Range USB CPE with N male connector	Model Name :	TUBE-U(N)
Temperature :	20 °C	Relative Humidity :	48%
Pressure :	1010 hPa	Test Voltage :	DC5V from PC
Test Mode :	CH1 (802.11g Mode)	Polarization :	Horizontal

Frequency (MHz)	Meter Reading (dBµV)	Factor (dB)	Emission Level (dBµV/m)	Limits (dBµV/m)	Margin (dB)	Detector Type
2400.00	19.50	32.65	52.15	74.00	-21.85	peak
2400.00	15.23	32.65	47.88	54.00	-6.12	AVG
4824.00	0.23	44.04	44.27	74.00	-29.73	peak
4824.00	-3.43	44.04	40.61	54.00	-13.39	AVG
7236.00	1.21	48.03	49.24	74.00	-24.76	peak
7236.00	-4.23	48.03	43.80	54.00	-10.20	AVG

Remark:

- Factor = Antenna Factor + Cable Loss – Pre-amplifier.
- No emission detected above 18GHz

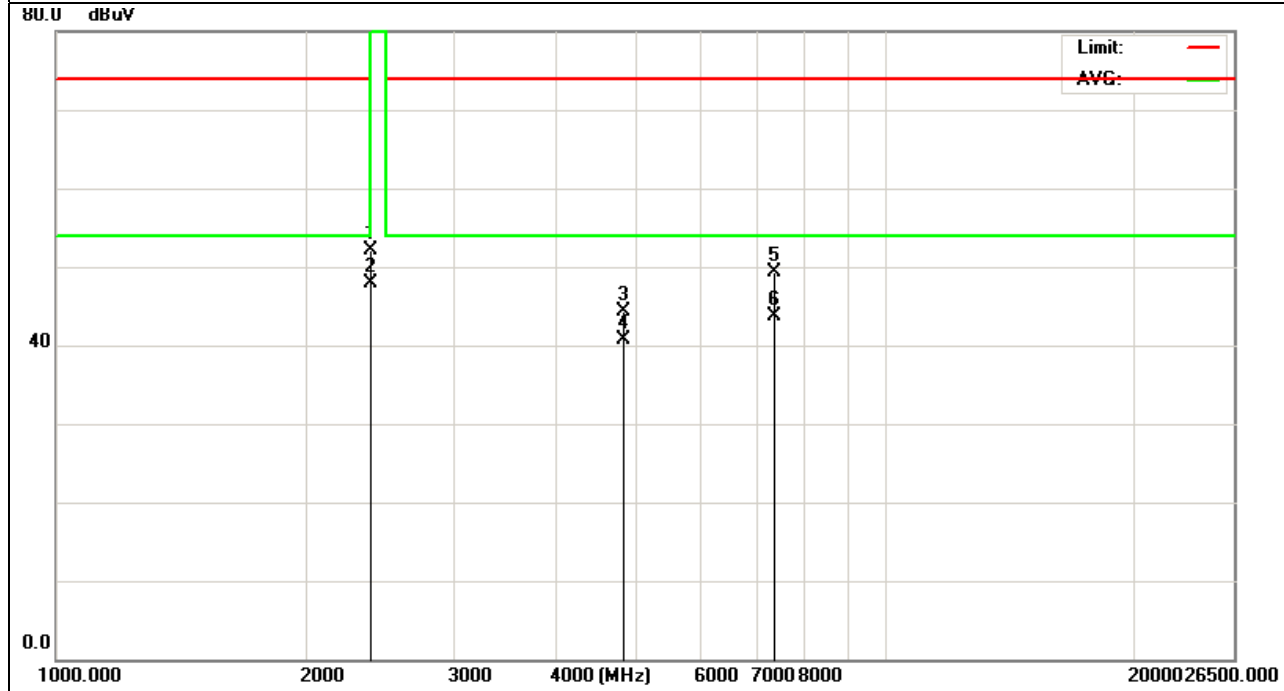

EUT :	Outdoor Long Range USB CPE with N male connector	Model Name :	TUBE-U(N)
Temperature :	20 °C	Relative Humidity :	48%
Pressure :	1010 hPa	Test Voltage :	DC5V from PC
Test Mode :	CH1 (802.11g Mode)	Polarization :	Vertical

Frequency (MHz)	Meter Reading (dBµV)	Factor (dB)	Emission Level (dBµV/m)	Limits (dBµV/m)	Margin (dB)	Detector Type
2400.00	20.09	32.65	52.74	74.00	-21.26	peak
2400.00	15.98	32.65	48.63	54.00	-5.37	AVG
4824.00	1.11	44.04	45.15	74.00	-28.85	peak
4824.00	-7.45	44.04	36.59	54.00	-17.41	AVG
7236.00	-3.33	47.63	44.30	74.00	-29.70	peak
7236.00	-5.43	47.63	42.20	54.00	-11.80	AVG

Remark:

- Factor = Antenna Factor + Cable Loss – Pre-amplifier.
- No emission detected above 18GHz

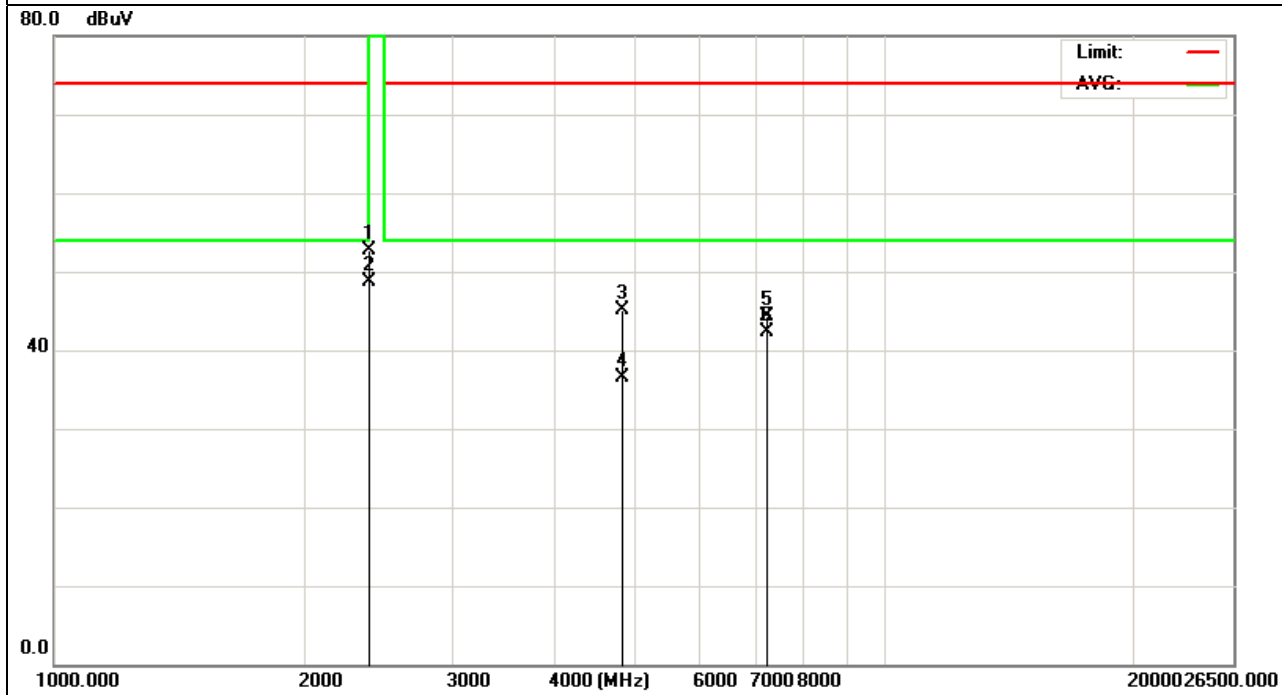

EUT :	Outdoor Long Range USB CPE with N male connector	Model Name :	TUBE-U(N)
Temperature :	20 °C	Relative Humidity :	48%
Pressure :	1010 hPa	Test Voltage :	DC5V from PC
Test Mode :	CH6 (802.11g Mode)	Polarization :	Horizontal

Frequency (MHz)	Meter Reading (dBµV)	Factor (dB)	Emission Level (dBµV/m)	Limits (dBµV/m)	Margin (dB)	Detector Type
4874.00	-0.13	44.07	43.94	74.00	-30.06	peak
4874.00	-4.25	44.07	39.82	54.00	-14.18	AVG
7311.00	-3.87	47.97	44.10	74.00	-29.90	peak
7311.00	-5.22	47.97	42.75	54.00	-11.25	AVG

Remark:

- Factor = Antenna Factor + Cable Loss – Pre-amplifier.
- No emission detected above 18GHz

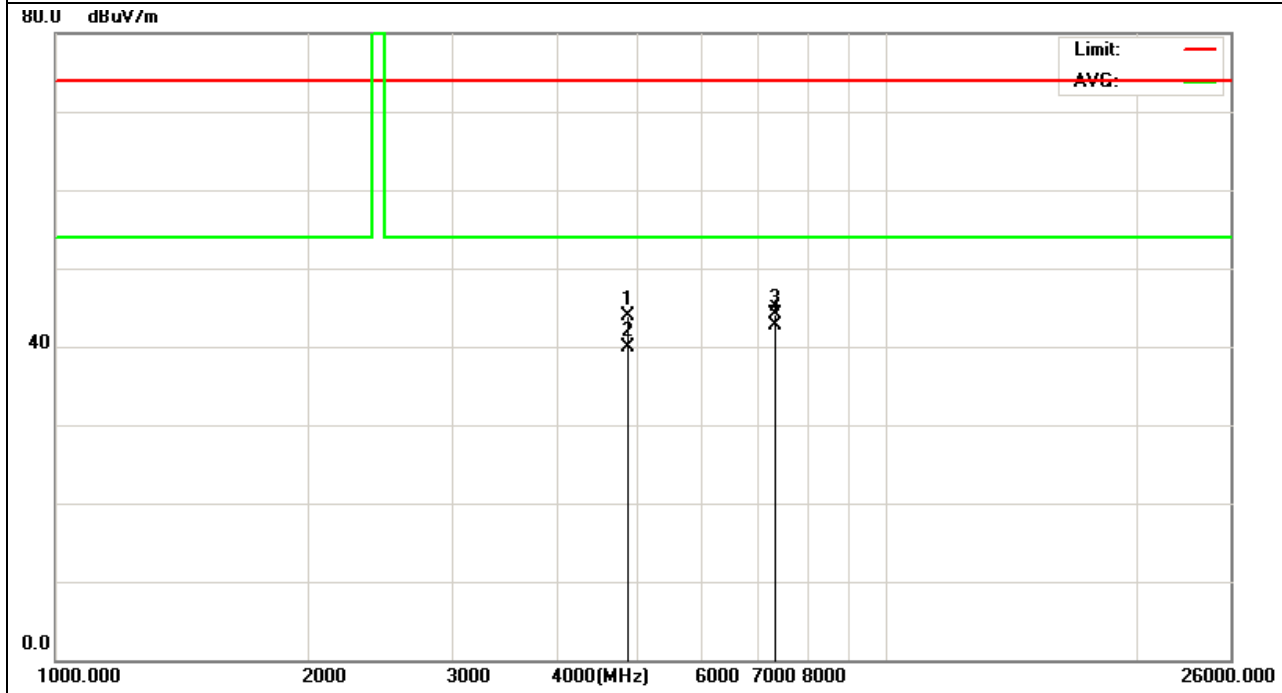

EUT :	Outdoor Long Range USB CPE with N male connector	Model Name :	TUBE-U(N)
Temperature :	20 °C	Relative Humidity :	48%
Pressure :	1010 hPa	Test Voltage :	DC5V from PC
Test Mode :	CH6 (802.11g Mode)	Polarization :	Vertical

Frequency (MHz)	Meter Reading (dBµV)	Factor (dB)	Emission Level (dBµV/m)	Limits (dBµV/m)	Margin (dB)	Detector Type
4874.00	1.32	44.07	45.39	74.00	-28.61	peak
4874.00	-3.54	44.07	40.53	54.00	-13.47	AVG
7311.00	0.54	47.97	48.51	74.00	-25.49	peak
7311.00	-4.31	47.97	43.66	54.00	-10.34	AVG

Remark:

- Factor = Antenna Factor + Cable Loss – Pre-amplifier.
- No emission detected above 18GHz

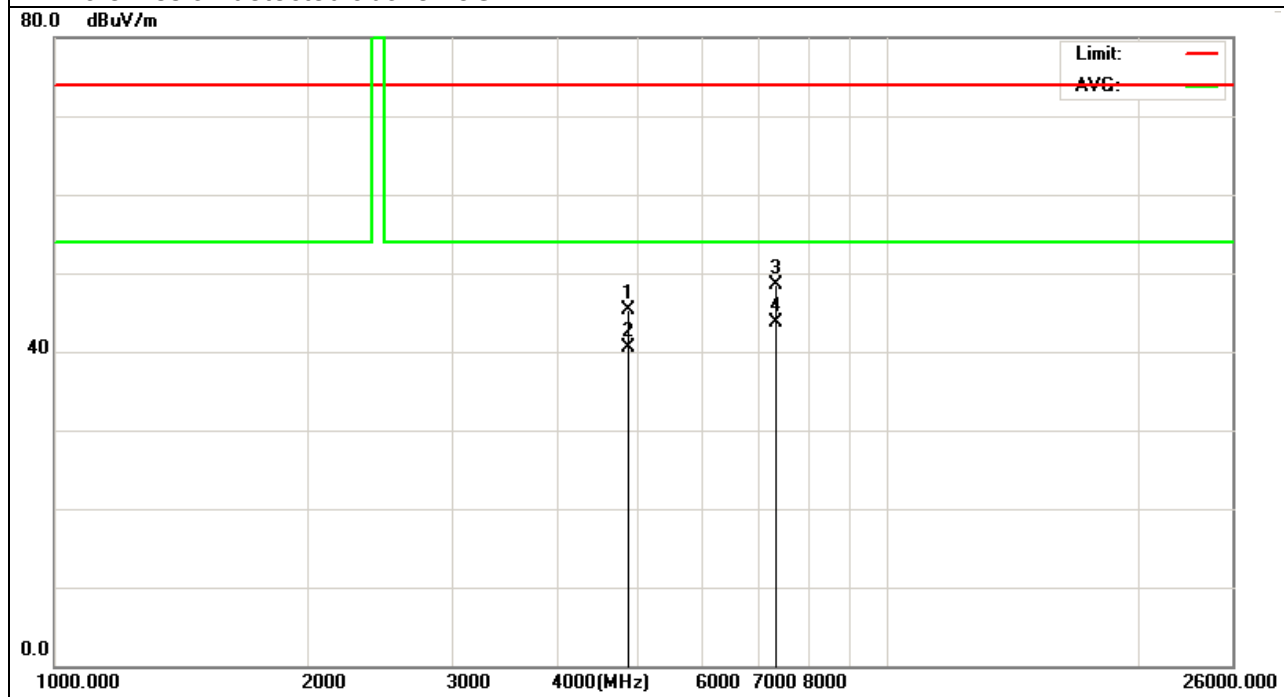



EUT :	Outdoor Long Range USB CPE with N male connector	Model Name :	TUBE-U(N)
Temperature :	20 °C	Relative Humidity :	48%
Pressure :	1010 hPa	Test Voltage :	DC5V from PC
Test Mode :	CH11 (802.11g Mode)	Polarization :	Horizontal

Frequency (MHz)	Meter Reading (dBµV)	Factor (dB)	Emission Level (dBµV/m)	Limits (dBµV/m)	Margin (dB)	Detector Type
2483.5	18.76	33.27	52.03	74.00	-21.97	peak
2483.5	14.43	33.27	47.70	54.00	-6.30	AVG
4924.00	7.43	44.10	51.53	74.00	-22.47	peak
4924.00	2.12	44.10	46.22	54.00	-7.78	AVG
7386.00	-4.15	48.31	44.16	74.00	-29.84	peak
7386.00	28.56	48.31	41.09	54.00	-12.91	AVG

Remark:

- Factor = Antenna Factor + Cable Loss – Pre-amplifier.
- No emission detected above 18GHz

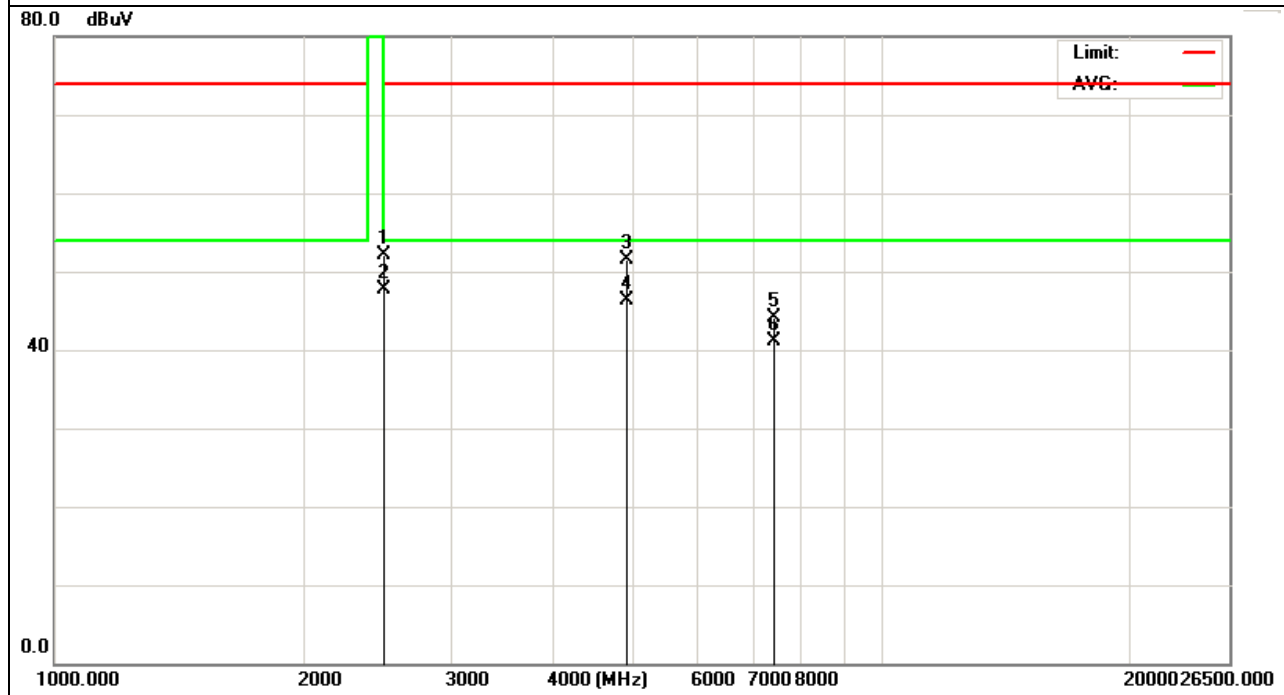

EUT :	Outdoor Long Range USB CPE with N male connector	Model Name :	TUBE-U(N)
Temperature :	20 °C	Relative Humidity :	48%
Pressure :	1010 hPa	Test Voltage :	DC5V from PC
Test Mode :	CH11(802.11g Mode)	Polarization :	Vertical

Frequency (MHz)	Meter Reading (dBµV)	Factor (dB)	Emission Level (dBµV/m)	Limits (dBµV/m)	Margin (dB)	Detector Type
2483.50	21.43	33.27	54.70	74.00	-19.30	peak
2483.50	14.34	33.27	47.61	54.00	-6.39	AVG
4924.00	5.67	44.10	49.77	74.00	-24.23	peak
4924.00	0.12	44.10	44.22	54.00	-9.78	AVG
7386.00	-4.21	48.31	44.10	74.00	-29.90	peak
7386.00	-8.13	48.31	40.18	54.00	-13.82	AVG

Remark:

- Factor = Antenna Factor + Cable Loss – Pre-amplifier.
- No emission detected above 18GHz

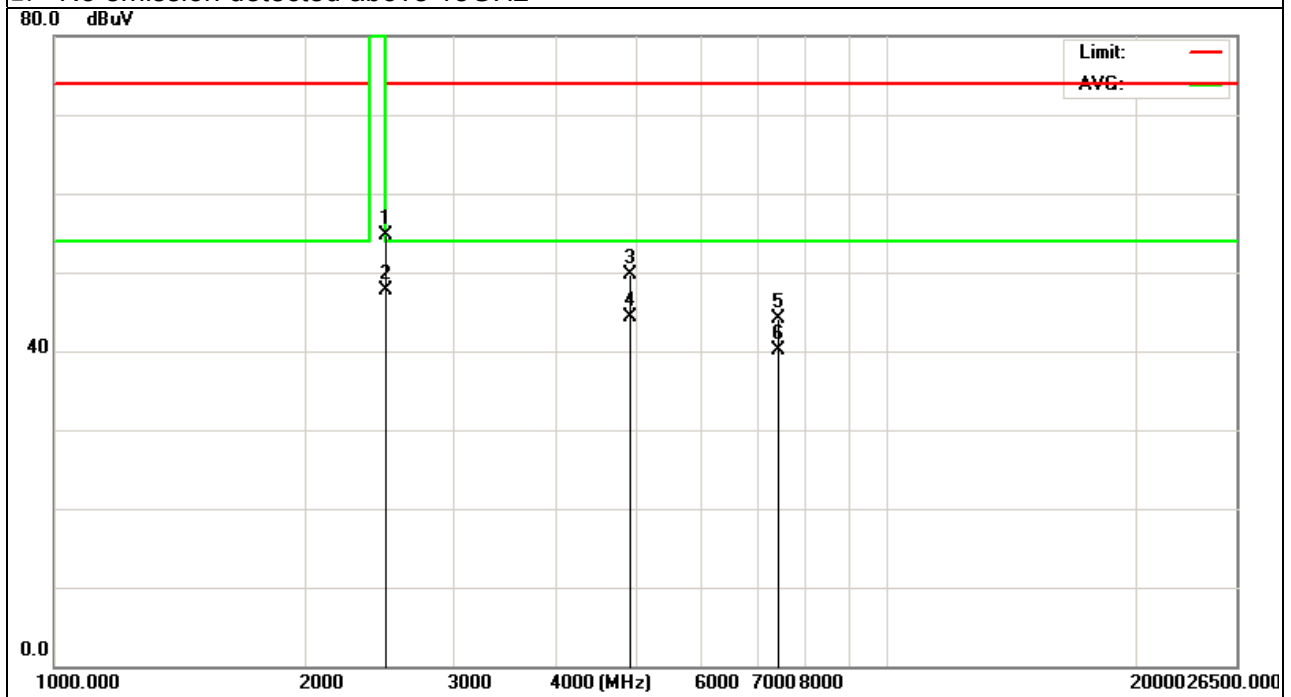

EUT :	Outdoor Long Range USB CPE with N male connector	Model Name :	TUBE-U(N)
Temperature :	20 °C	Relative Humidity :	48%
Pressure :	1010 hPa	Test Voltage :	DC5V from PC
Test Mode :	CH1 (802.11N Mode,20MHz)	Polarization :	Horizontal

Frequency (MHz)	Meter Reading (dBµV)	Factor (dB)	Emission Level (dBµV/m)	Limits (dBµV/m)	Margin (dB)	Detector Type
2400.00	18.12	32.65	50.77	74.00	-23.23	peak
2400.00	14.12	32.65	46.77	54.00	-7.23	AVG
4824.00	3.13	44.04	47.17	74.00	-26.83	peak
4824.00	-3.33	44.04	40.71	54.00	-13.29	AVG
7236.00	-5.14	48.03	42.89	74.00	-31.11	peak
7236.00	-10.22	48.03	37.81	54.00	-16.19	AVG

Remark:

- 3. Factor = Antenna Factor + Cable Loss – Pre-amplifier.
- 4. No emission detected above 18GHz

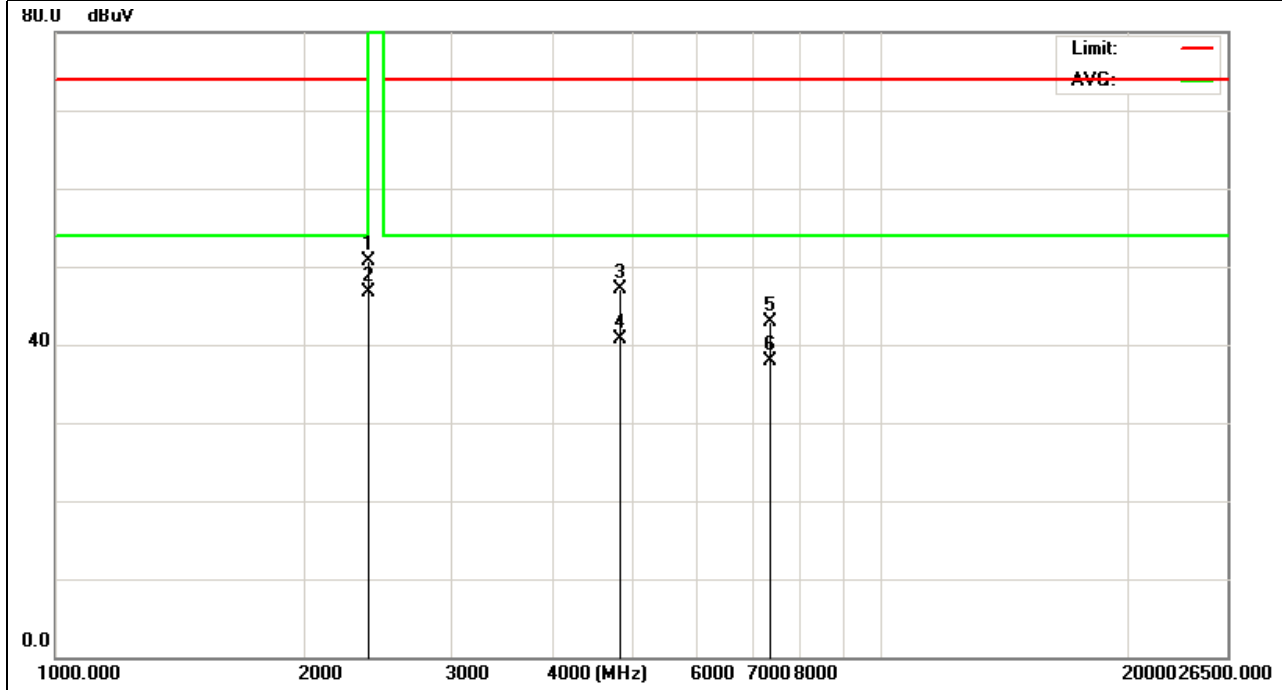

EUT :	Outdoor Long Range USB CPE with N male connector	Model Name :	TUBE-U(N)
Temperature :	20 °C	Relative Humidity :	48%
Pressure :	1010 hPa	Test Voltage :	DC5V from PC
Test Mode :	CH1 (802.11N Mode,20MHz)	Polarization :	Vertical

Frequency (MHz)	Meter Reading (dBµV)	Factor (dB)	Emission Level (dBµV/m)	Limits (dBµV/m)	Margin (dB)	Detector Type
2400.00	19.99	32.65	52.64	74.00	-21.36	peak
2400.00	15.98	32.65	48.63	54.00	-5.37	AVG
4824.00	4.96	44.04	49.00	74.00	-25.00	peak
4824.00	-3.10	44.04	40.90	54.00	-13.06	AVG
7236.00	-2.13	48.03	45.90	74.00	-28.10	peak
7236.00	-6.18	48.03	41.85	54.00	-12.15	AVG

Remark:

- 3. Factor = Antenna Factor + Cable Loss – Pre-amplifier.
- 4. No emission detected above 18GHz

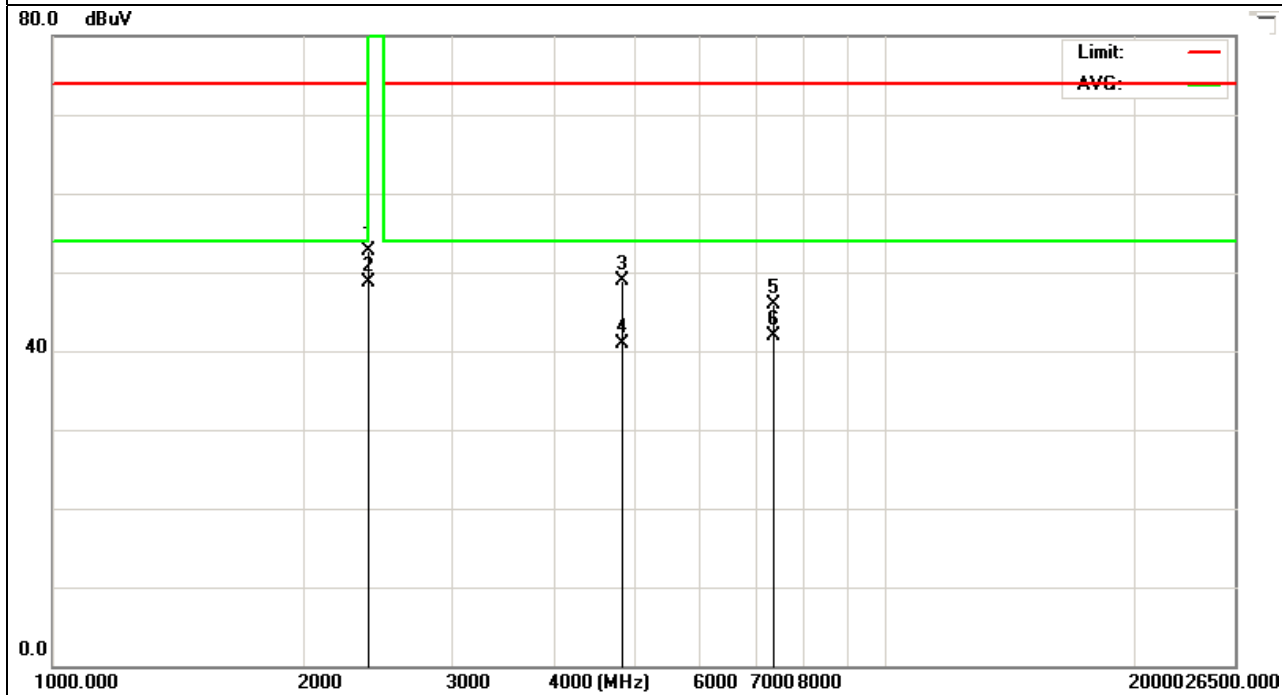

EUT :	Outdoor Long Range USB CPE with N male connector	Model Name :	TUBE-U(N)
Temperature :	20 °C	Relative Humidity :	48%
Pressure :	1010 hPa	Test Voltage :	DC5V from PC
Test Mode :	CH6 (802.11N Mode,20MHz)	Polarization :	Horizontal

Frequency (MHz)	Meter Reading (dBµV)	Factor (dB)	Emission Level (dBµV/m)	Limits (dBµV/m)	Margin (dB)	Detector Type
4874.00	4.24	44.07	48.07	74.00	-25.70	peak
4874.00	0.05	44.07	44.12	54.00	-9.88	AVG
7311.00	-3.11	47.97	44.86	74.00	-29.14	peak
7311.00	-7.11	47.97	40.86	54.00	-13.14	AVG

Remark:

- 3. Factor = Antenna Factor + Cable Loss – Pre-amplifier.
- 4. No emission detected above 18GHz

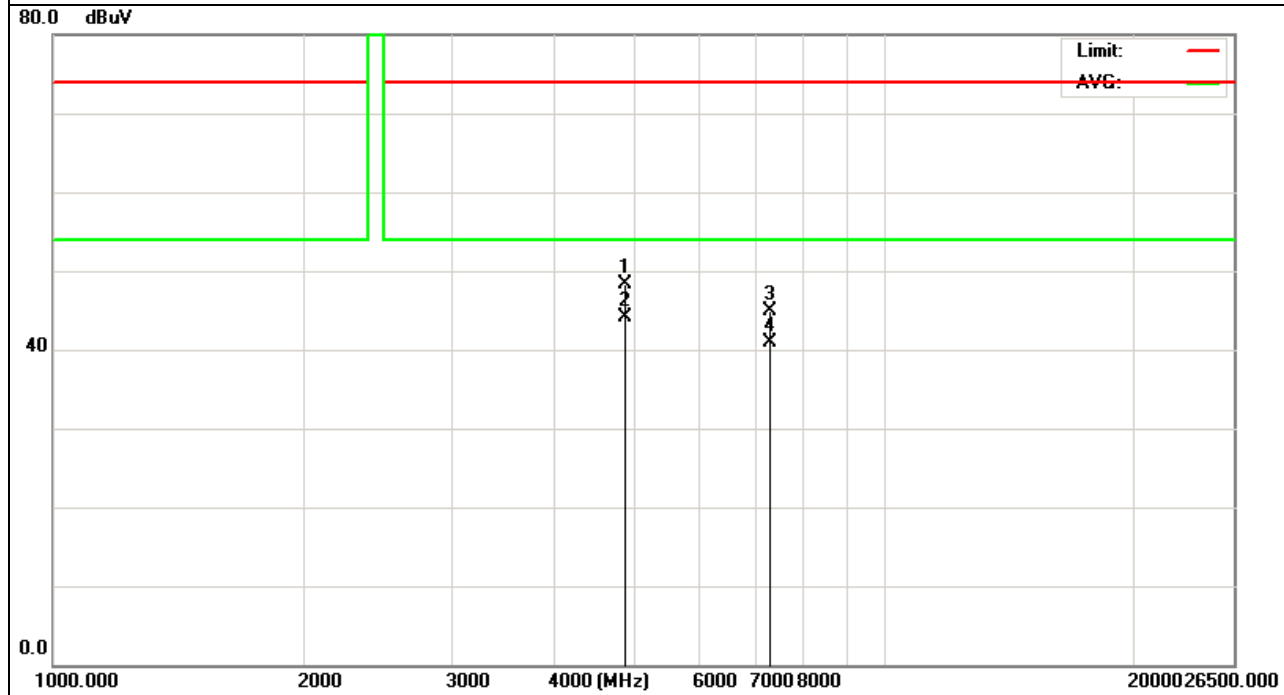

EUT :	Outdoor Long Range USB CPE with N male connector	Model Name :	TUBE-U(N)
Temperature :	20 °C	Relative Humidity :	48%
Pressure :	1010 hPa	Test Voltage :	DC5V from PC
Test Mode :	CH6 (802.11N Mode,20MHz)	Polarization :	Vertical

Frequency (MHz)	Meter Reading (dBµV)	Factor (dB)	Emission Level (dBµV/m)	Limits (dBµV/m)	Margin (dB)	Detector Type
4874.00	5.89	44.07	49.96	74.00	-24.04	peak
4874.00	-1.11	44.07	42.96	54.00	-11.04	AVG
7311.00	-1.21	47.97	46.76	74.00	-27.24	peak
7311.00	-6.34	47.97	41.63	54.00	-12.37	AVG

Remark:  
 3. Factor = Antenna Factor + Cable Loss – Pre-amplifier.  
 4. No emission detected above 18GHz

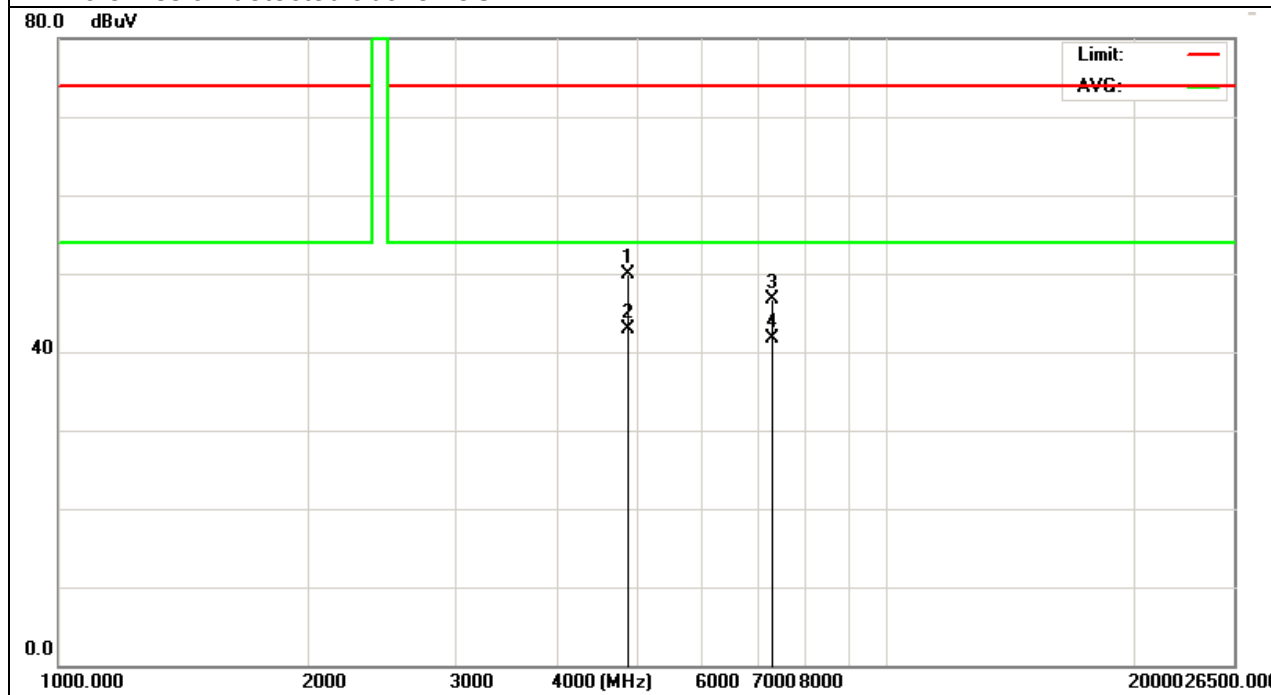

EUT :	Outdoor Long Range USB CPE with N male connector	Model Name :	TUBE-U(N)
Temperature :	20 °C	Relative Humidity :	48%
Pressure :	1010 hPa	Test Voltage :	DC5V from PC
Test Mode :	CH11 (802.11N Mode,20MHz)	Polarization :	Horizontal

Frequency (MHz)	Meter Reading (dBµV)	Factor (dB)	Emission Level (dBµV/m)	Limits (dBµV/m)	Margin (dB)	Detector Type
2483.5	16.31	33.27	49.58	74.00	-24.42	peak
2483.5	12.31	33.27	45.58	54.00	-8.42	AVG
4924.00	3.12	44.10	47.22	74.00	-26.78	peak
4924.00	-4.19	44.10	39.91	54.00	-14.09	AVG
7386.00	-5.12	48.31	43.19	74.00	-30.81	peak
7386.00	-9.77	48.31	38.54	54.00	-15.46	AVG

Remark:

- 3. Factor = Antenna Factor + Cable Loss – Pre-amplifier.
- 4. No emission detected above 18GHz

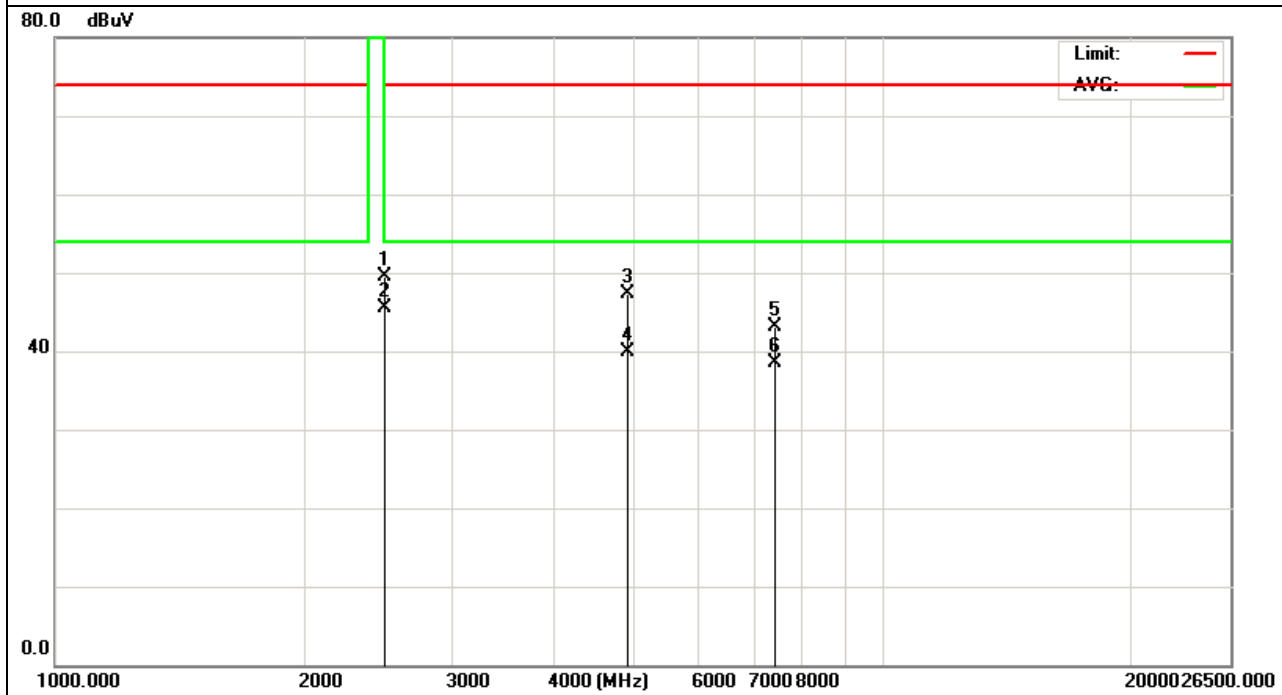

EUT :	Outdoor Long Range USB CPE with N male connector	Model Name :	TUBE-U(N)
Temperature :	20 °C	Relative Humidity :	48%
Pressure :	1010 hPa	Test Voltage :	DC 5V from PC
Test Mode :	CH11(802.11N Mode,20MHz)	Polarization :	Vertical

Frequency (MHz)	Meter Reading (dBµV)	Factor (dB)	Emission Level (dBµV/m)	Limits (dBµV/m)	Margin (dB)	Detector Type
2483.50	21.43	33.27	54.70	74.00	-19.30	peak
2483.50	14.34	33.27	47.61	54.00	-6.39	AVG
4924.00	5.67	44.10	49.77	74.00	-24.23	peak
4924.00	0.12	44.10	44.22	54.00	-9.78	AVG
7386.00	-4.21	48.31	44.10	74.00	-29.90	peak
7386.00	-8.13	48.31	40.18	54.00	-13.82	AVG

Remark:

- 3. Factor = Antenna Factor + Cable Loss – Pre-amplifier.
- 4. No emission detected above 18GHz

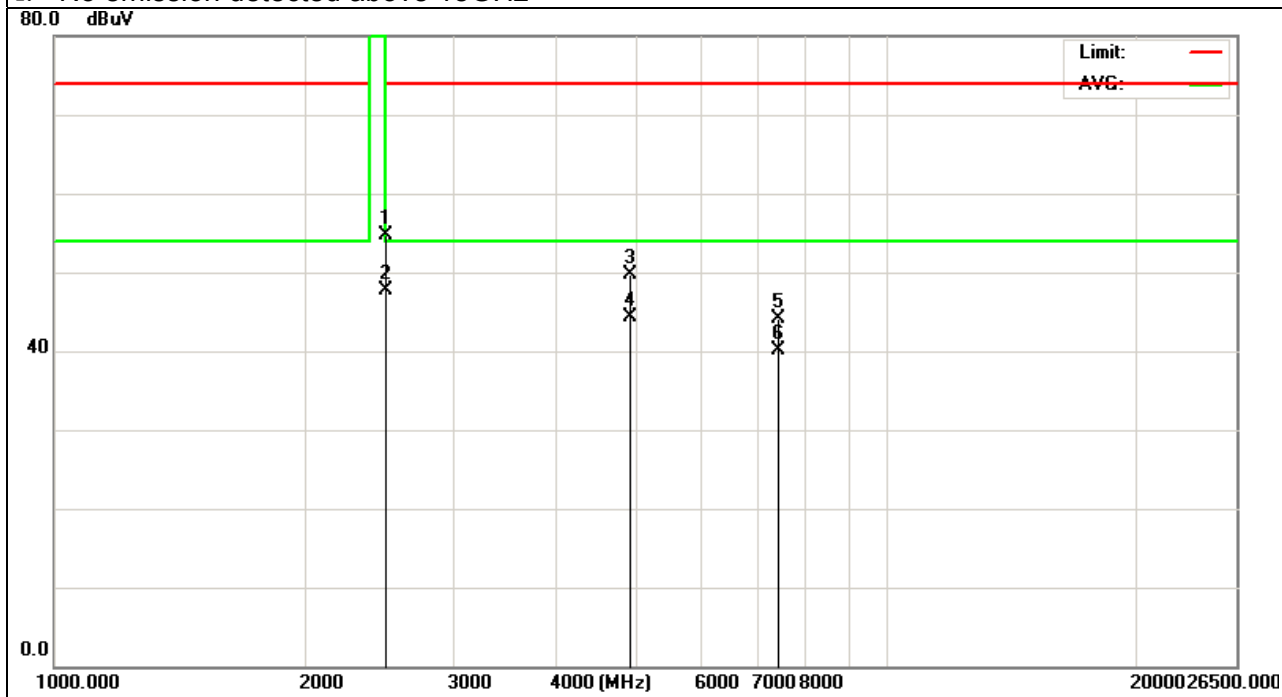



EUT :	Outdoor Long Range USB CPE with N male connector	Model Name :	TUBE-U(N)
Temperature :	20 °C	Relative Humidity :	48%
Pressure :	1010 hPa	Test Voltage :	DC 5V from PC
Test Mode :	CH2 (802.11N Mode,40MHz)	Polarization :	Horizontal

Frequency (MHz)	Meter Reading (dBµV)	Factor (dB)	Emission Level (dBµV/m)	Limits (dBµV/m)	Margin (dB)	Detector Type
2400.00	18.87	32.65	51.52	74.00	-22.48	peak
2400.00	15.21	32.65	47.86	54.00	-6.14	AVG
4844.00	4.11	44.04	48.15	74.00	-25.85	peak
4844.00	-3.22	44.04	40.82	54.00	-13.18	AVG
7266.00	-5.13	48.03	42.90	74.00	-31.10	peak
7266.00	-8.77	48.03	39.26	54.00	-14.74	AVG

Remark:

- 5. Factor = Antenna Factor + Cable Loss – Pre-amplifier.
- 6. No emission detected above 18GHz

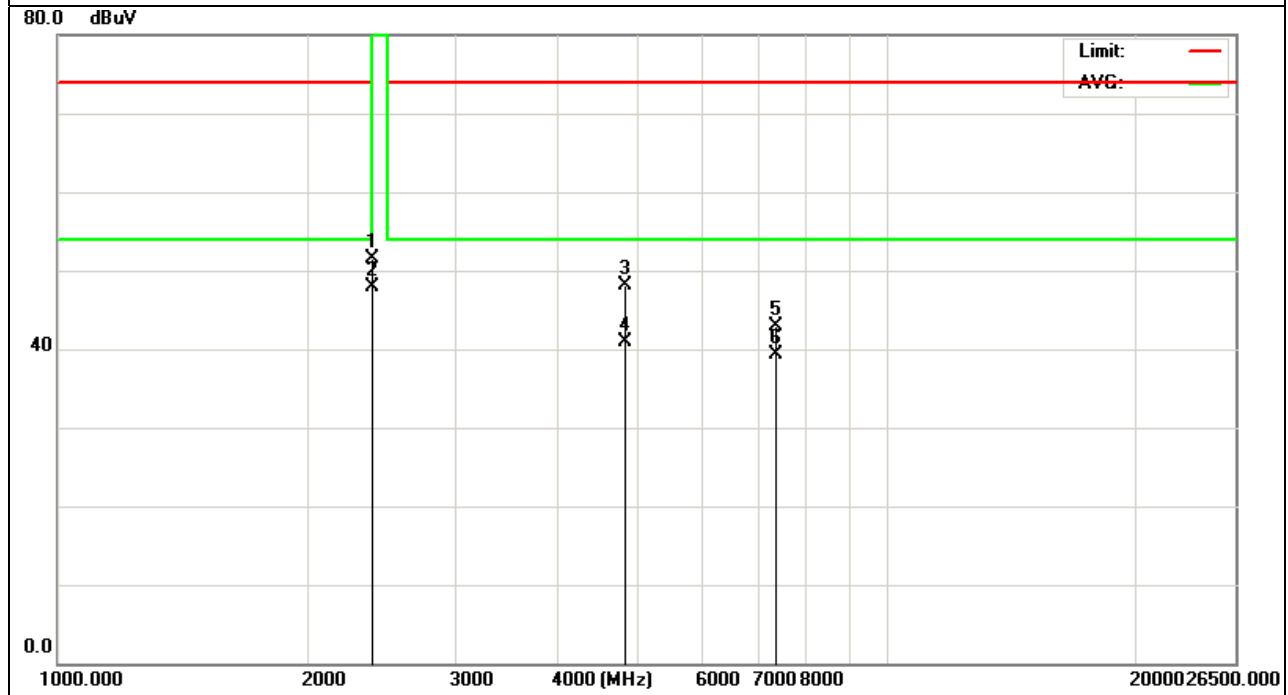

EUT :	Outdoor Long Range USB CPE with N male connector	Model Name :	TUBE-U(N)
Temperature :	20 °C	Relative Humidity :	48%
Pressure :	1010 hPa	Test Voltage :	DC 5V from PC
Test Mode :	CH2 (802.11N Mode,40MHz)	Polarization :	Vertical

Frequency (MHz)	Meter Reading (dBµV)	Factor (dB)	Emission Level (dBµV/m)	Limits (dBµV/m)	Margin (dB)	Detector Type
2400.00	19.99	32.65	52.64	74.00	-21.36	peak
2400.00	15.98	32.65	48.63	54.00	-5.37	AVG
4844.00	4.96	44.04	49.00	74.00	-25.00	peak
4844.00	-3.10	44.04	40.90	54.00	-13.06	AVG
7266.00	-5.13	48.03	42.90	74.00	-31.10	peak
7266.00	-6.18	48.03	41.85	54.00	-12.15	AVG

Remark:

- 5. Factor = Antenna Factor + Cable Loss – Pre-amplifier.
- 6. No emission detected above 18GHz

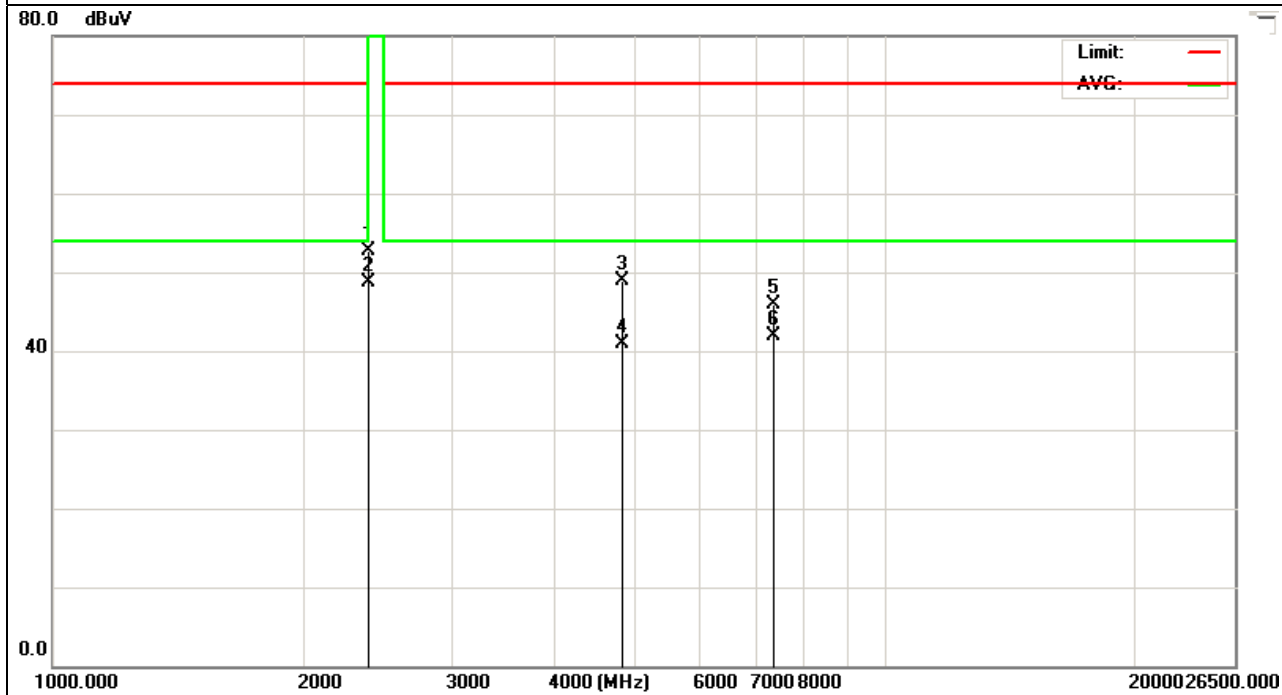

EUT :	Outdoor Long Range USB CPE with N male connector	Model Name :	TUBE-U(N)
Temperature :	20 °C	Relative Humidity :	48%
Pressure :	1010 hPa	Test Voltage :	DC 5V from PC
Test Mode :	CH10 (802.11N Mode,40MHz)	Polarization :	Horizontal

Frequency (MHz)	Meter Reading (dBμV)	Factor (dB)	Emission Level (dBμV/m)	Limits (dBμV/m)	Margin (dB)	Detector Type
2483.5	15.34	33.27	48.62	74.00	-25.39	peak
2483.5	10.43	33.27	43.70	54.00	-10.30	AVG
4904.00	-1.13	44.09	42.96	74.00	-31.04	peak
4904.00	-6.88	44.09	37.21	54.00	-16.79	AVG

Remark:

- 5. Factor = Antenna Factor + Cable Loss – Pre-amplifier.
- 6. No emission detected above 18GHz

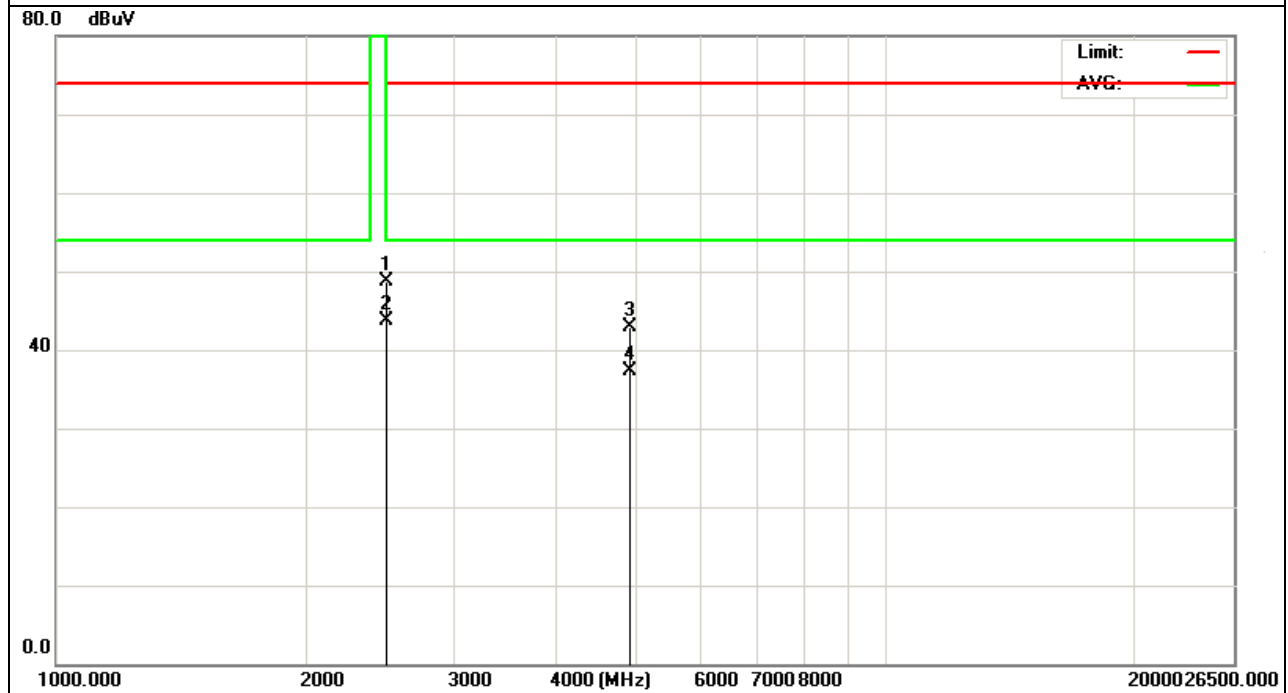

EUT :	Outdoor Long Range USB CPE with N male connector	Model Name :	TUBE-U(N)
Temperature :	20 °C	Relative Humidity :	48%
Pressure :	1010 hPa	Test Voltage :	DC 5V from PC
Test Mode :	CH10(802.11N Mode,40MHz)	Polarization :	Vertical

Frequency (MHz)	Meter Reading (dBµV)	Factor (dB)	Emission Level (dBµV/m)	Limits (dBµV/m)	Margin (dB)	Detector Type
2483.5	13.31	33.27	46.58	74.00	-27.42	peak
2483.5	8.81	33.27	42.08	54.00	-11.92	AVG
4904.00	-4.12	44.09	39.97	74.00	-34.03	peak
4904.00	-7.33	44.09	36.76	54.00	-17.24	AVG

Remark:

- 5. Factor = Antenna Factor + Cable Loss – Pre-amplifier.
- 6. No emission detected above 18GHz

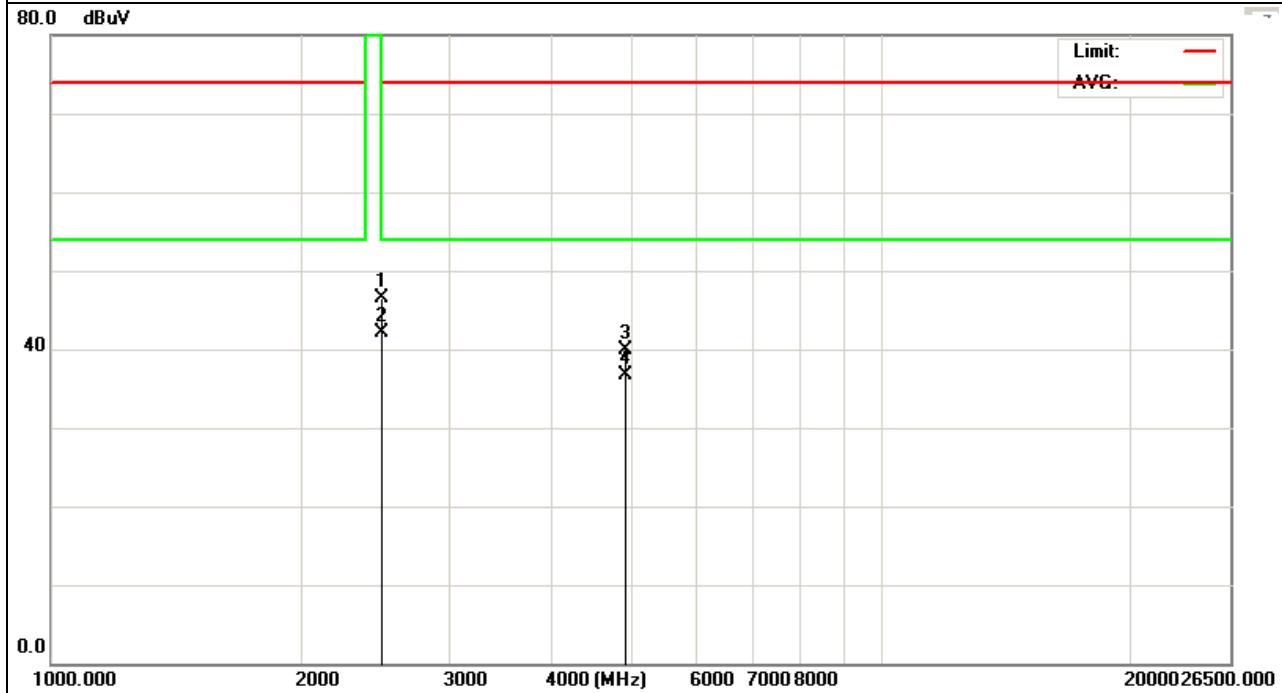

#### 4. POWER SPECTRAL DENSITY TEST

##### 4.1 APPLIED PROCEDURES / LIMIT

FCC Part15 (15.247) , Subpart C				
Section	Test Item	Limit	Frequency Range (MHz)	Result
15.247 (d) & A8.2	Power Spectral Density	8 dBm (in any 3KHz)	2400-2483.5	PASS

Spectrum Parameters	Setting
Attenuation	Auto
Span Frequency	> Operating Frequency Range
RB	3 kHz
VB	30 kHz
Detector	Peak
Trace	Max Hold
Sweep Time	500s

##### 4.1.1 TEST PROCEDURE

- a. The EUT was directly connected to the spectrum analyzer and antenna output port as show in the block diagram below,
- b. Spectrum Setting : RBW= 3KHz, VBW=30KHz, Sweep time = 500s.

##### 4.1.2 DEVIATION FROM STANDARD

No deviation.

##### 4.1.3 TEST SETUP

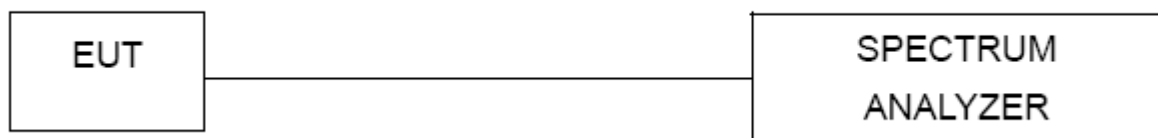

##### 4.1.4 EUT OPERATION CONDITIONS

The EUT tested system was configured as the statements of 4.1.6 Unless otherwise a special operating condition is specified in the follows during the testing.

### 4.1.5 TEST RESULTS

EUT :	Outdoor Long Range USB CPE with N male connector	Model Name :	TUBE-U(N)
Temperature :	25 °C	Relative Humidity :	60%
Pressure :	1015 hPa	Test Voltage :	DC 5V from PC
Test Mode :	TX B MODE /CH01, CH06, CH11		

Frequency	Power Density (dBm)	Limit (dBm)	Result
2412 MHz	-11.15	8	<b>PASS</b>
2437 MHz	-11.70	8	<b>PASS</b>
2462 MHz	-12.32	8	<b>PASS</b>

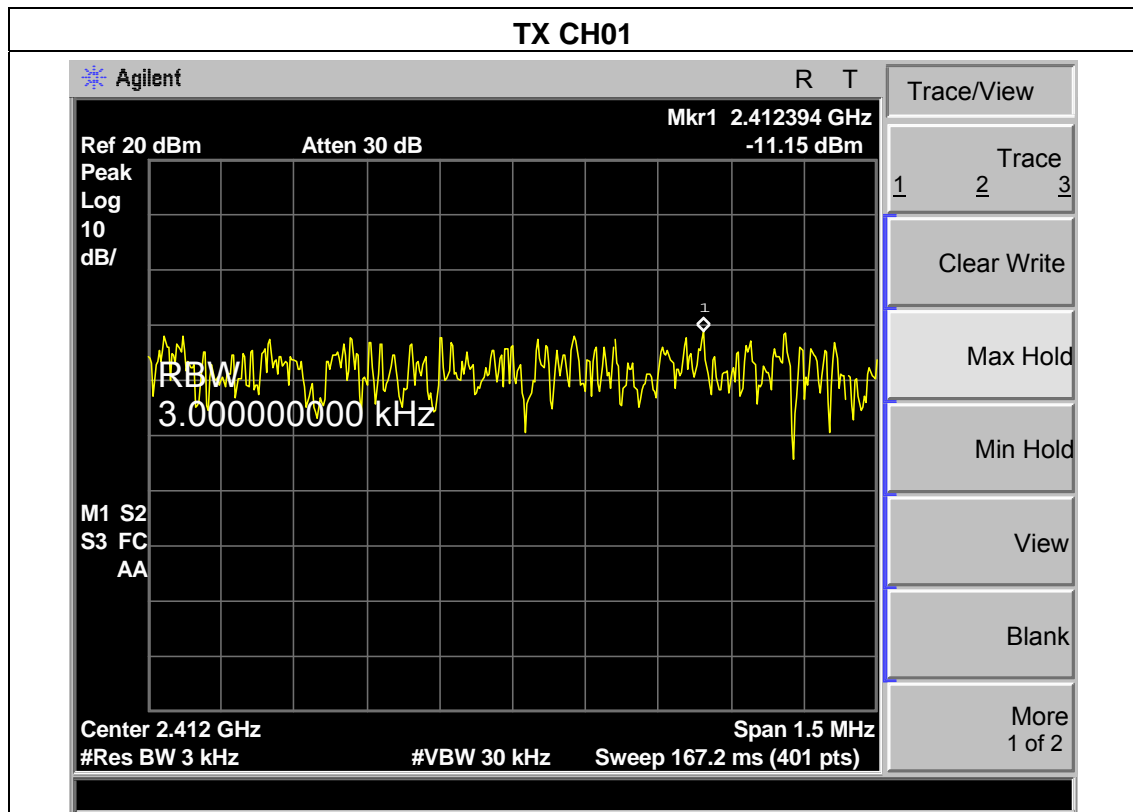

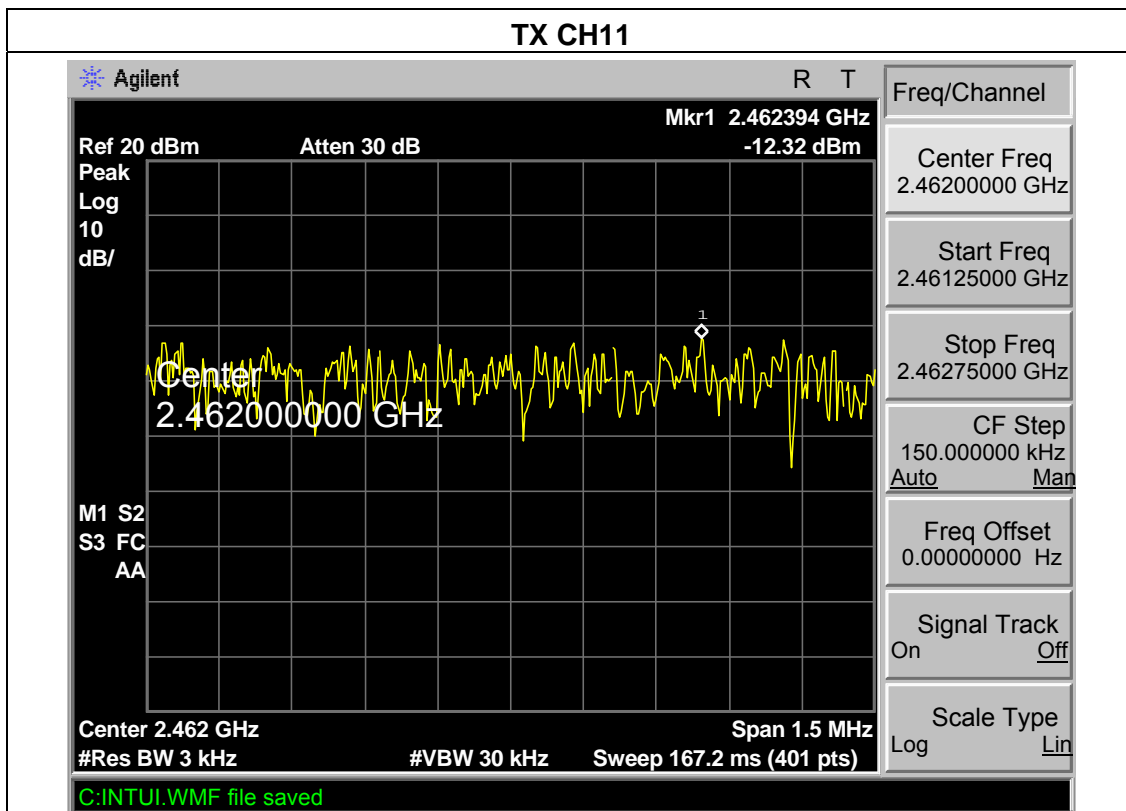
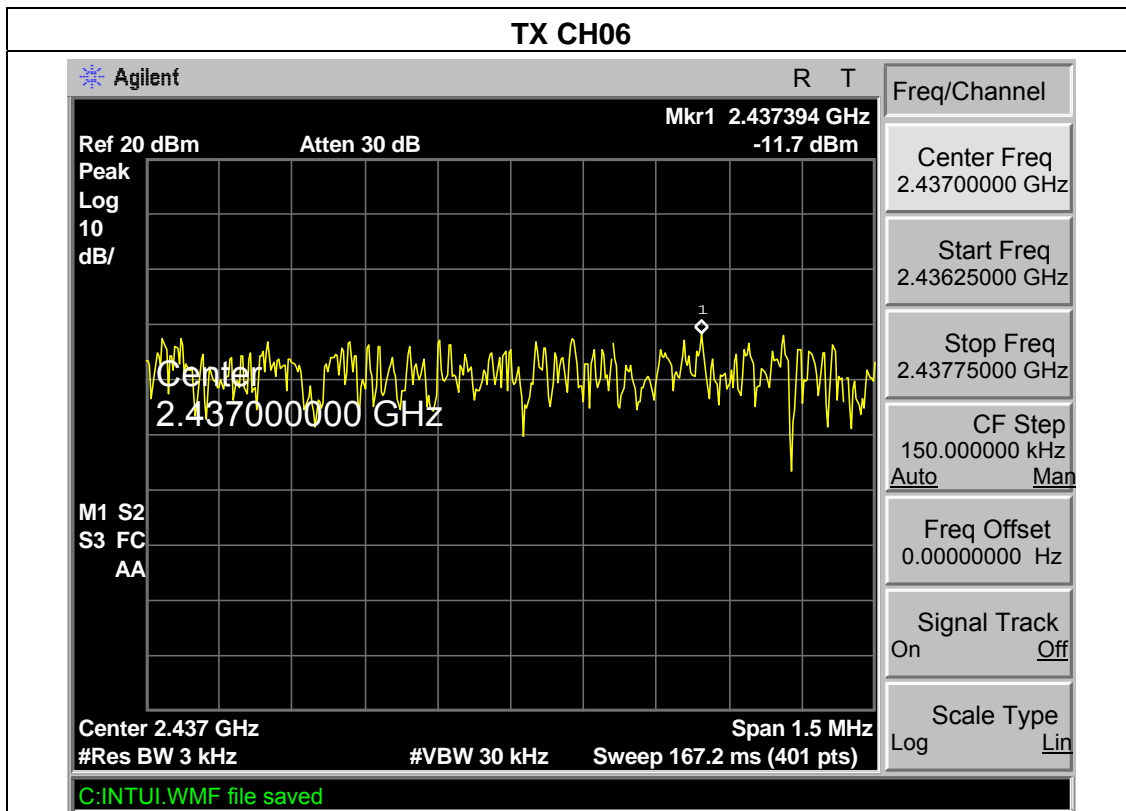

EUT :	Outdoor Long Range USB CPE with N male connector	Model Name :	TUBE-U(N)
Temperature :	25 °C	Relative Humidity :	60%
Pressure :	1015 hPa	Test Voltage :	DC 5V from PC
Test Mode :	TX G MODE /CH01, CH06, CH11		

Frequency	Power Density (dBm)	Limit (dBm)	Result
2412 MHz	-16.62	8	<b>PASS</b>
2437MHz	-19.25	8	<b>PASS</b>
2462 MHz	-17.50	8	<b>PASS</b>

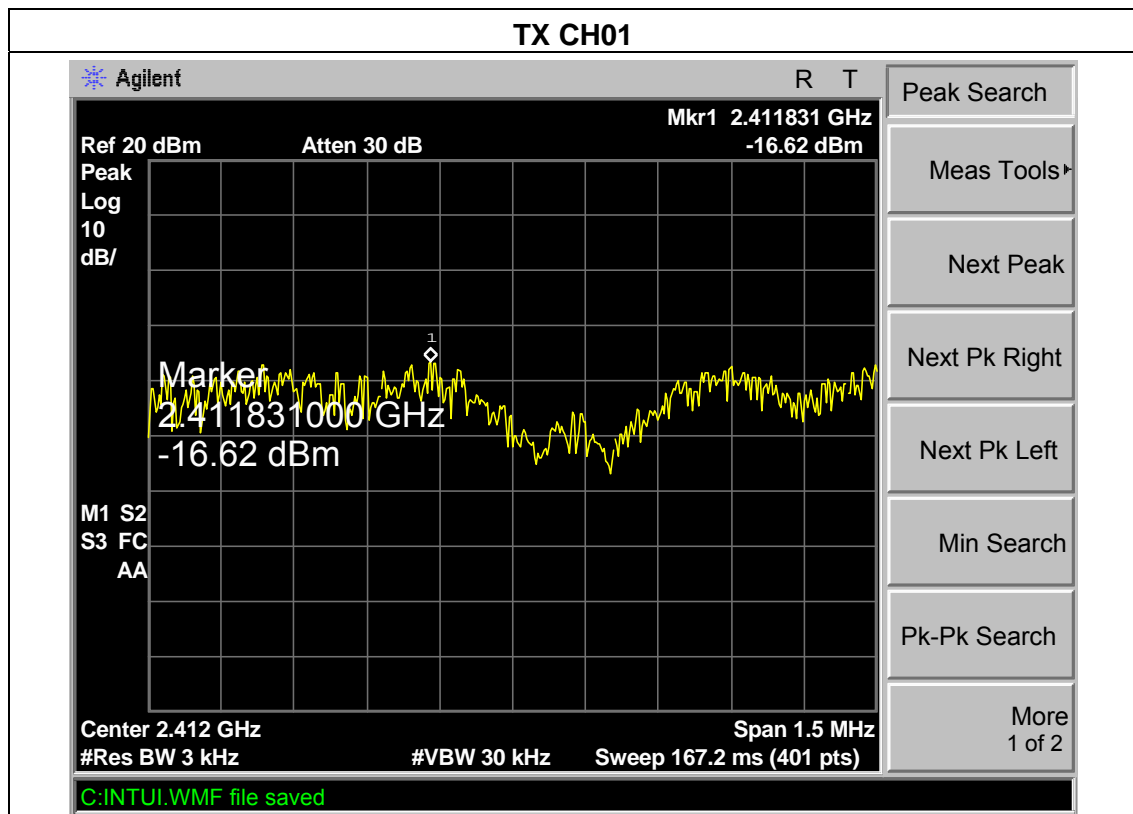



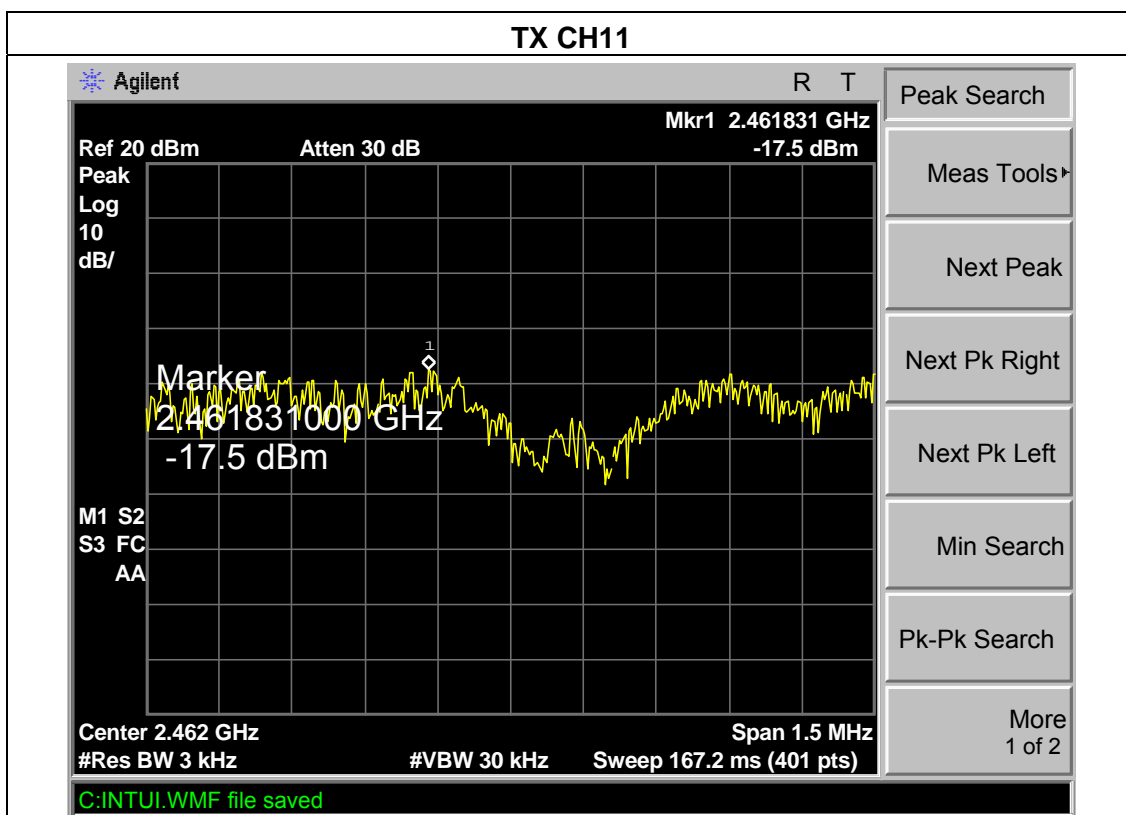
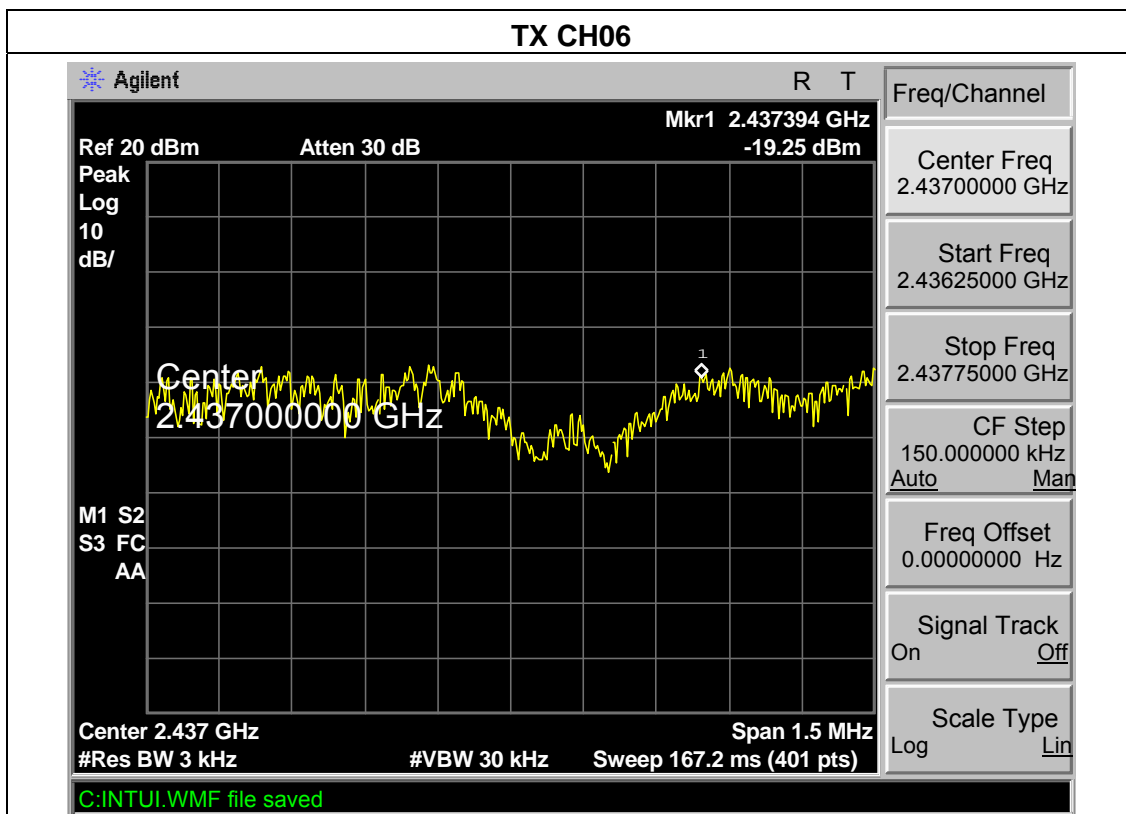

EUT :	Outdoor Long Range USB CPE with N male connector	Model Name :	TUBE-U(N)
Temperature :	25 °C	Relative Humidity :	60%
Pressure :	1015 hPa	Test Voltage :	DC5V from PC
Test Mode :	TX N MODE /CH01, CH06, CH11, 20MHz		

Frequency	Power Density (dBm)	Limit (dBm)	Result
2412 MHz	-19.45	8	<b>PASS</b>
2437MHz	-19.78	8	<b>PASS</b>
2462 MHz	-19.88	8	<b>PASS</b>

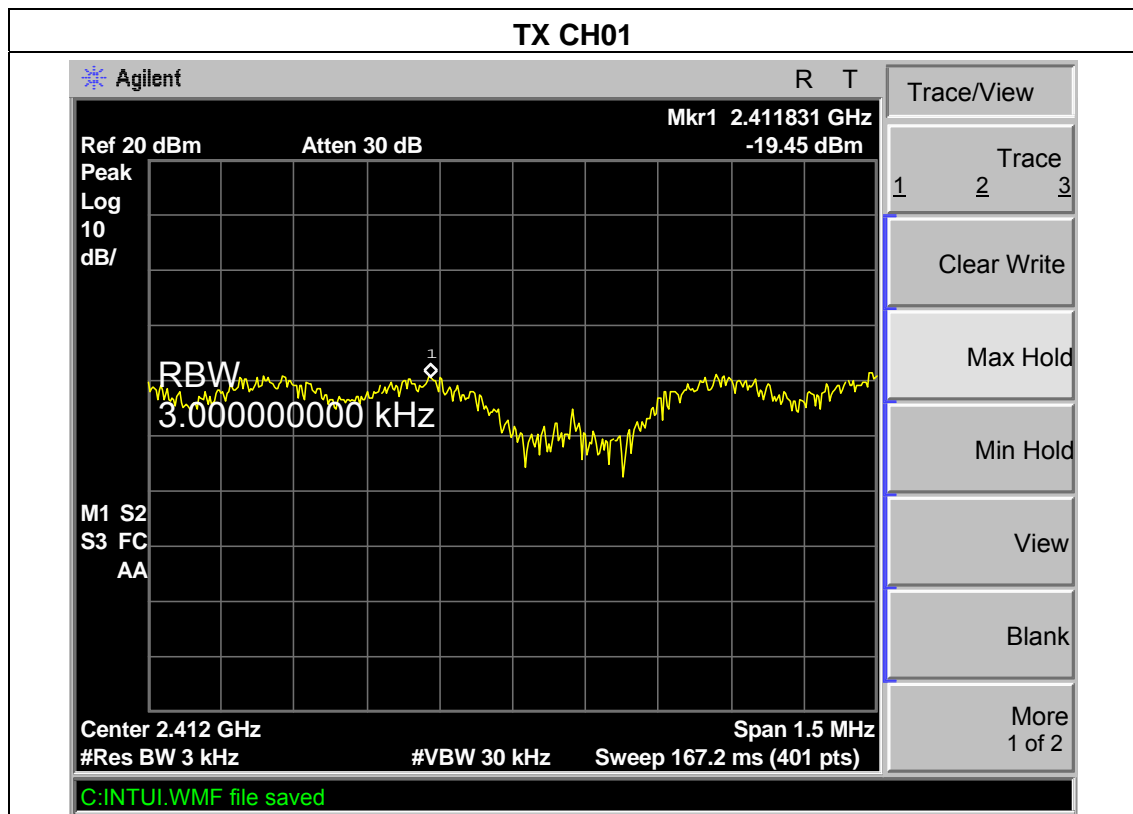

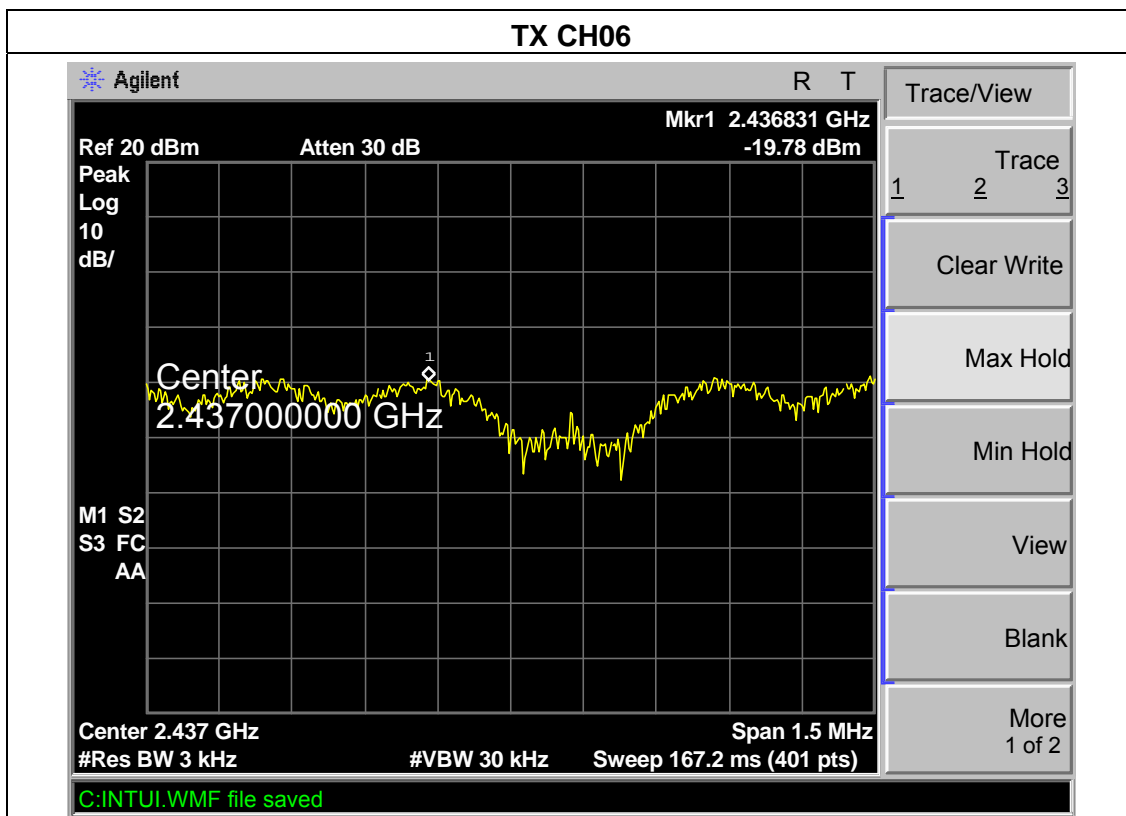

EUT :	Outdoor Long Range USB CPE with N male connector	Model Name :	TUBE-U(N)
Temperature :	25 °C	Relative Humidity :	60%
Pressure :	1015 hPa	Test Voltage :	DC5V from PC
Test Mode :	TX N MODE /CH01, CH06, CH11, 40MHz		

Frequency	Power Density (dBm)	Limit (dBm)	Result
2422 MHz	-20.65	8	<b>PASS</b>
2452 MHz	-20.94	8	<b>PASS</b>

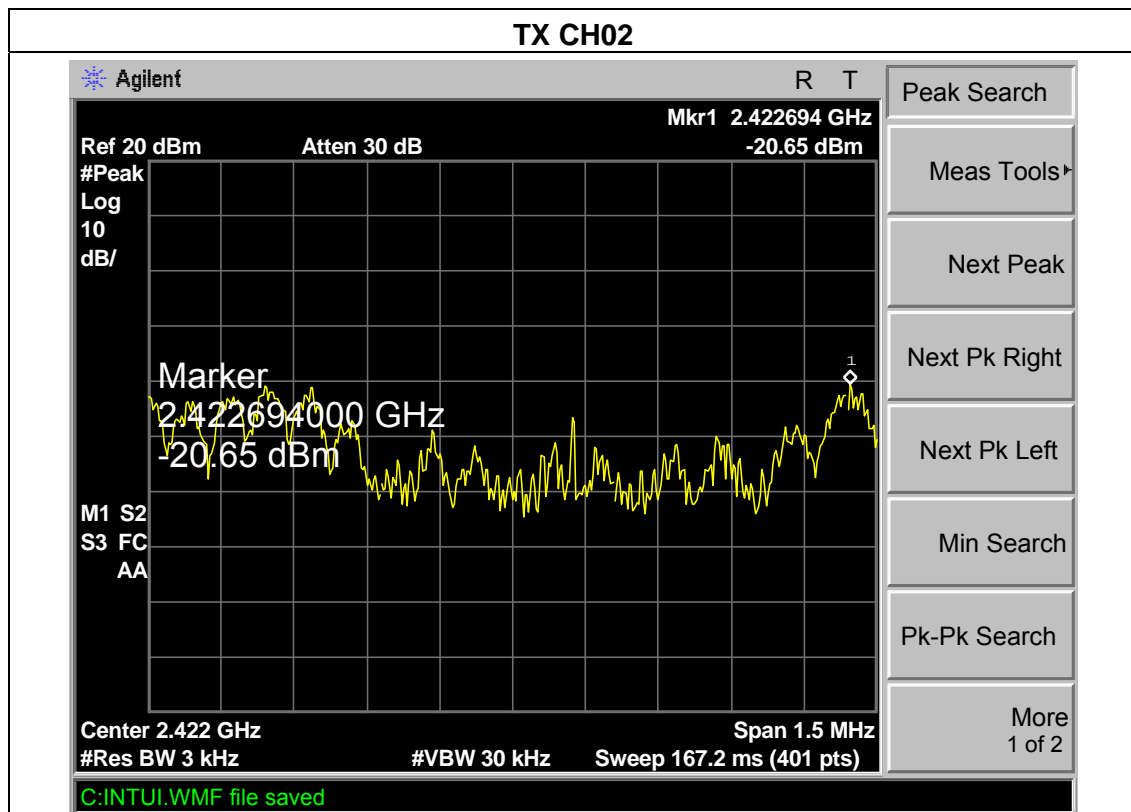

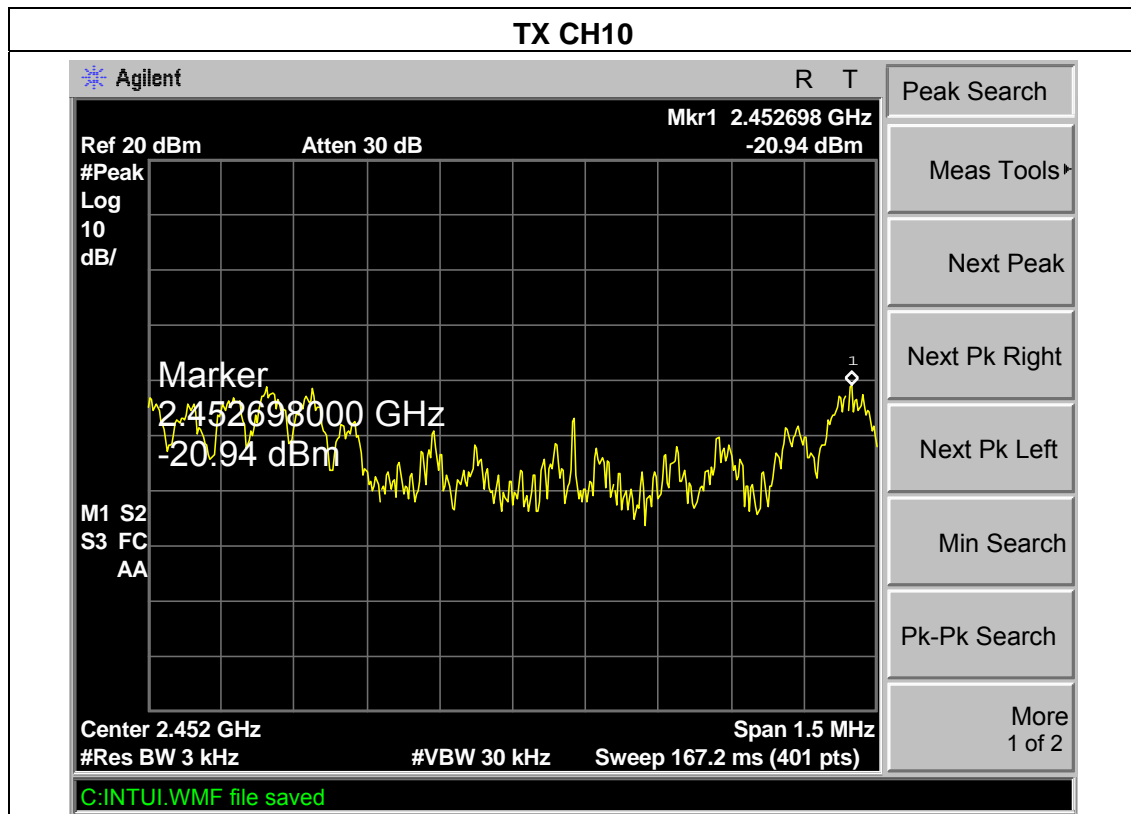

## 5. BANDWIDTH TEST

### 5.1 APPLIED PROCEDURES / LIMIT

FCC Part15 (15.247) , Subpart C & RSS-210 Annex 8				
Section	Test Item	Limit	Frequency Range (MHz)	Result
15.247 (a)(2)& A8.2	Bandwidth	$\geq 500\text{KHz}$ (6dB bandwidth)	2400-2483.5	PASS

Spectrum Parameter	Setting
Attenuation	Auto
Span Frequency	$>$ Measurement Bandwidth or Channel Separation
RB	30 kHz (20dB Bandwidth) / 100 kHz (Channel Separation)
VB	100 kHz (20dB Bandwidth) / 300 kHz (Channel Separation)
Detector	Peak
Trace	Max Hold
Sweep Time	Auto

#### 5.1.1 TEST PROCEDURE

- a. The EUT was directly connected to the spectrum analyzer and antenna output port as show in the block diagram below,
- b. Spectrum Setting : RBW= 100KHz, VBW=100KHz, Sweep time = Auto.

#### 5.1.2 DEVIATION FROM STANDARD

No deviation.

#### 5.1.3 TEST SETUP

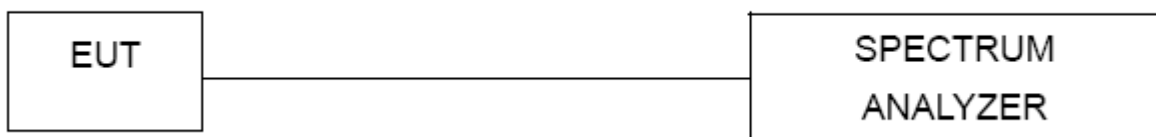

#### 5.1.4 EUT OPERATION CONDITIONS

The EUT tested system was configured as the statements of 4.1.6 Unless otherwise a special operating condition is specified in the follows during the testing.

### 5.1.5 TEST RESULTS

EUT :	Outdoor Long Range USB CPE with N male connector	Model Name :	TUBE-U(N)
Temperature :	25 °C	Relative Humidity :	60%
Pressure :	1012 hPa	Test Voltage :	DC 5V from PC
Test Mode :	TX B MODE /CH01, CH06, CH11		

Frequency	6dB Bandwidth (MHz)	99% Occupied BW (MHz)	Channel Separation (MHz)	Result
2412 MHz	11.16	13.79	>=500KHz	<b>PASS</b>
2437 MHz	11.13	13.79	>=500KHz	<b>PASS</b>
2462 MHz	11.13	13.79	>=500KHz	<b>PASS</b>

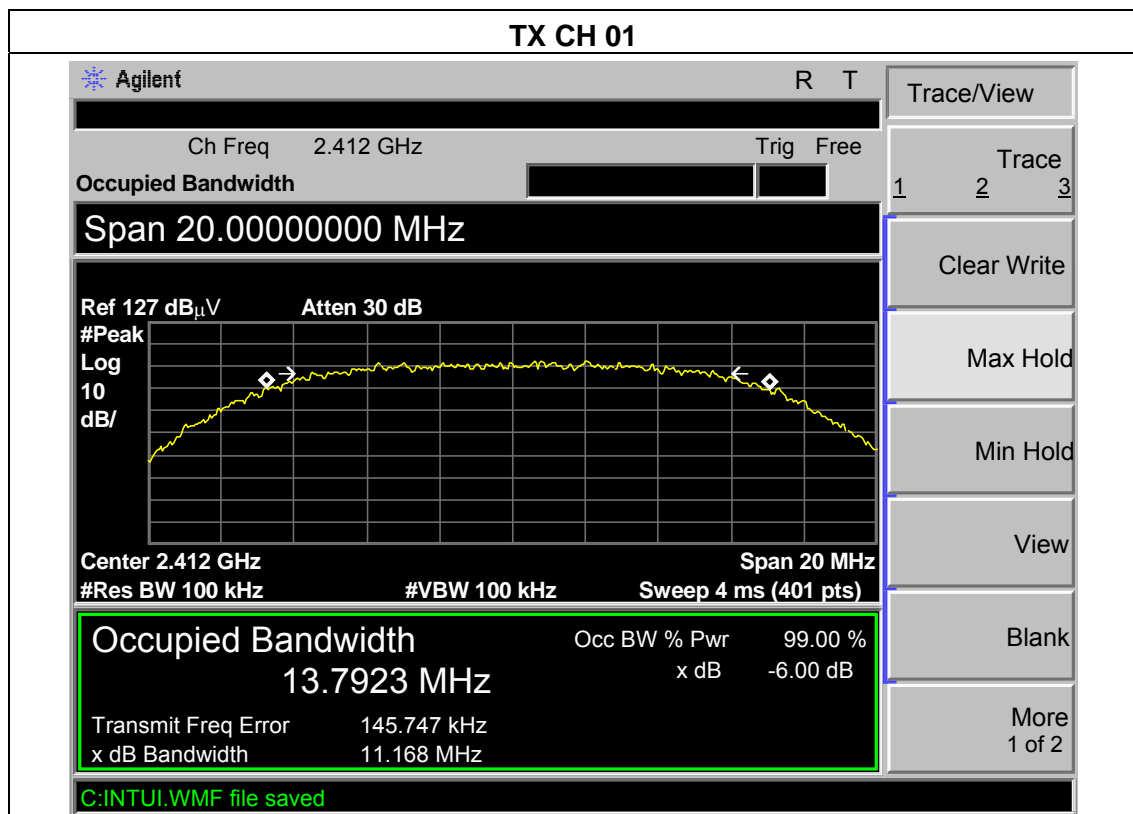

### TX CH 06

Agilent
R T

Ch Freq 2.437 GHz
Trig Free

**Occupied Bandwidth**

Center 2.43700000 GHz

Ref 127 dB $\mu$ V
Atten 30 dB

#Peak  
Log  
10  
dB/

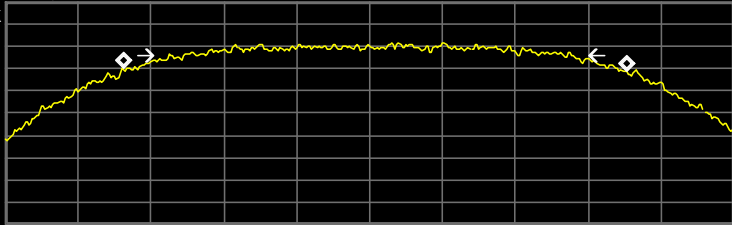

Center 2.437 GHz
Span 20 MHz

#Res BW 100 kHz
#VBW 100 kHz
Sweep 4 ms (401 pts)

Occupied Bandwidth	Occ BW % Pwr	99.00 %
13.7948 MHz	x dB	-6.00 dB
Transmit Freq Error	137.869 kHz	
x dB Bandwidth	11.131 MHz	

C:INTUI.WMF file saved

Freq/Channel	
Center Freq	2.43700000 GHz
Start Freq	2.42700000 GHz
Stop Freq	2.44700000 GHz
CF Step	2.00000000 MHz
Auto	Man
Freq Offset	0.00000000 Hz
Signal Track	On <u>Off</u>
Scale Type	Log <u>Lin</u>

### TX CH 11

Agilent
R T

Ch Freq 2.462 GHz
Trig Free

**Occupied Bandwidth**

Center 2.46200000 GHz

Ref 127 dB $\mu$ V
Atten 30 dB

#Peak  
Log  
10  
dB/

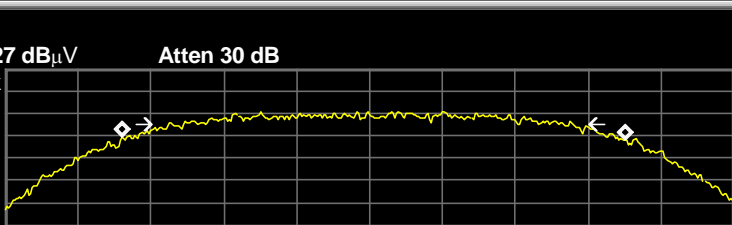

Center 2.462 GHz
Span 20 MHz

#Res BW 100 kHz
#VBW 100 kHz
Sweep 4 ms (401 pts)

Occupied Bandwidth	Occ BW % Pwr	99.00 %
13.7984 MHz	x dB	-6.00 dB
Transmit Freq Error	122.447 kHz	
x dB Bandwidth	11.132 MHz	

C:INTUI.WMF file saved

Freq/Channel	
Center Freq	2.46200000 GHz
Start Freq	2.45200000 GHz
Stop Freq	2.47200000 GHz
CF Step	2.00000000 MHz
Auto	Man
Freq Offset	0.00000000 Hz
Signal Track	On <u>Off</u>
Scale Type	Log <u>Lin</u>



EUT :	Outdoor Long Range USB CPE with N male connector	Model Name :	TUBE-U(N)
Temperature :	25 °C	Relative Humidity :	60%
Pressure :	1012 hPa	Test Voltage :	DC 5v from PC
Test Mode :	TX G MODE /CH01, CH06, CH11		

Frequency	6dB Bandwidth (MHz)	99% Occupied BW (MHz)	Channel Separation (MHz)	Result
2412 MHz	16.52	16.39	>=500KHz	<b>PASS</b>
2437 MHz	16.49	16.36	>=500KHz	<b>PASS</b>
2462 MHz	16.49	16.37	>=500KHz	<b>PASS</b>

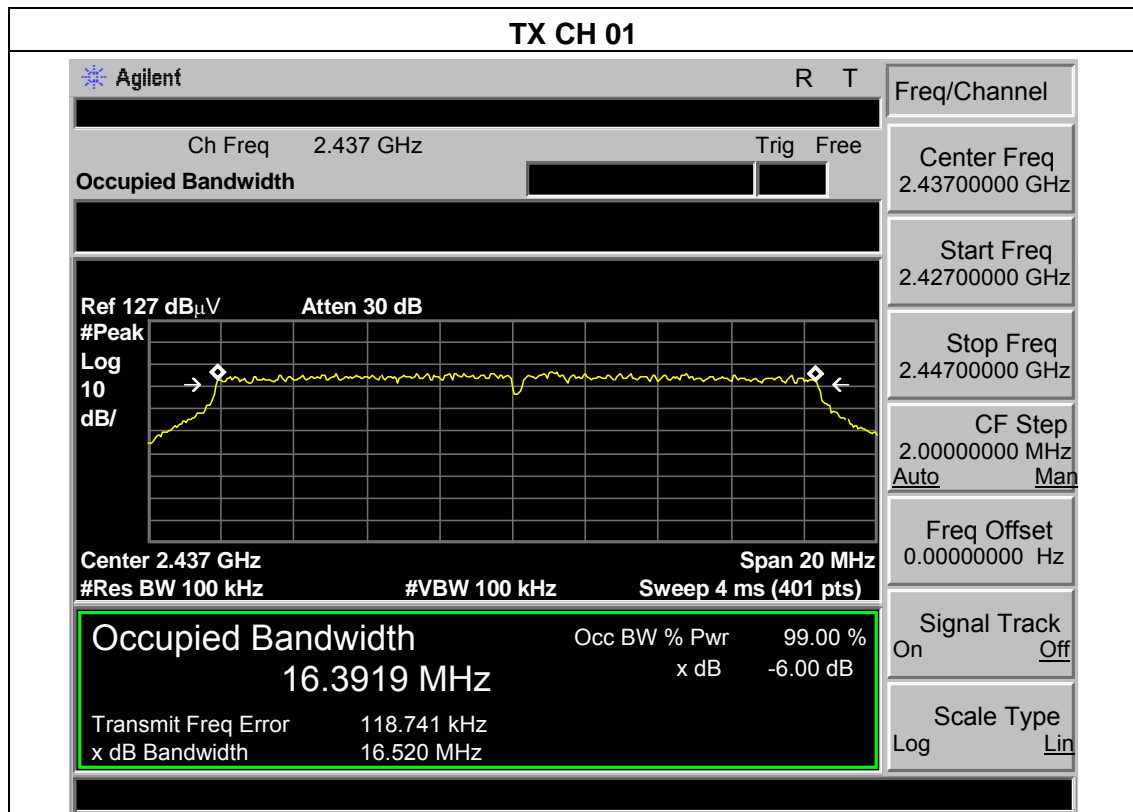

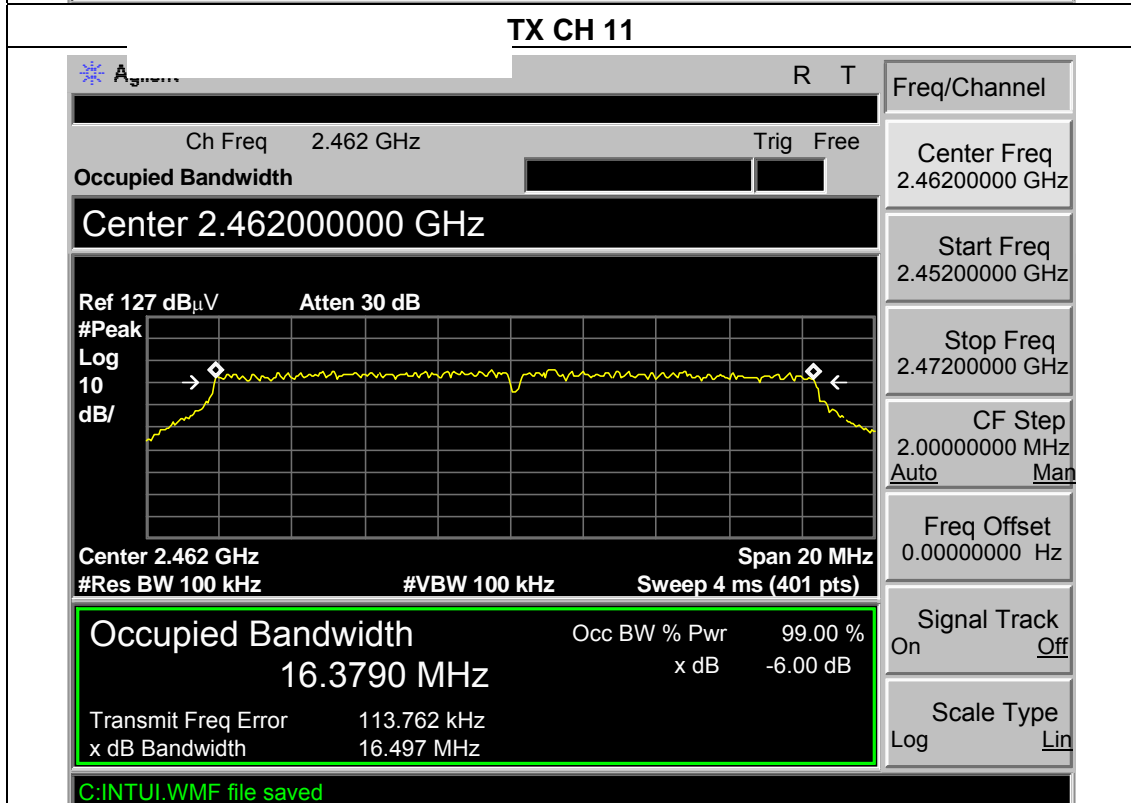
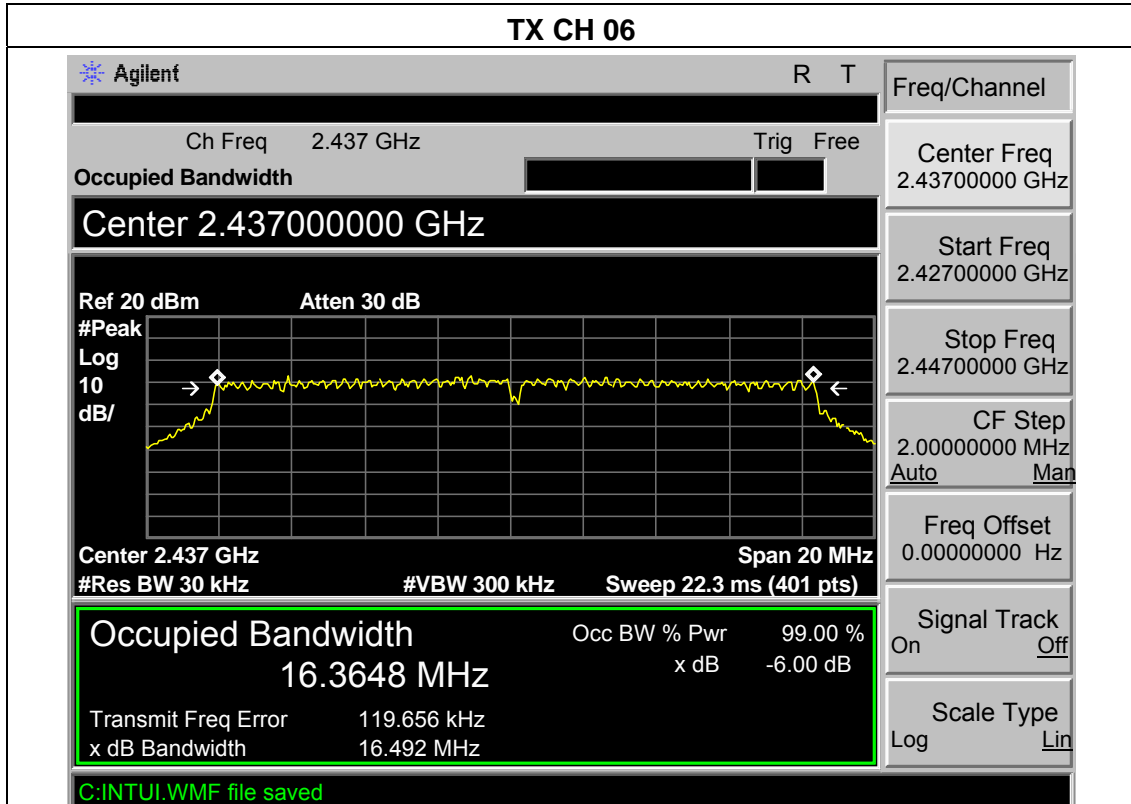

EUT :	Outdoor Long Range USB CPE with N male connector	Model Name :	TUBE-U(N)
Temperature :	25 °C	Relative Humidity :	60%
Pressure :	1012 hPa	Test Voltage :	DC 5V From PC
Test Mode :	TX N MODE /CH01, CH06, CH11(20MHz)		

Frequency	6dB Bandwidth (MHz)	99% Occupied BW (MHz)	Channel Separation (MHz)	Result
2412 MHz	16.50	16.38	>=500KHz	<b>PASS</b>
2437 MHz	16.51	16.38	>=500KHz	<b>PASS</b>
2462 MHz	16.49	16.39	>=500KHz	<b>PASS</b>

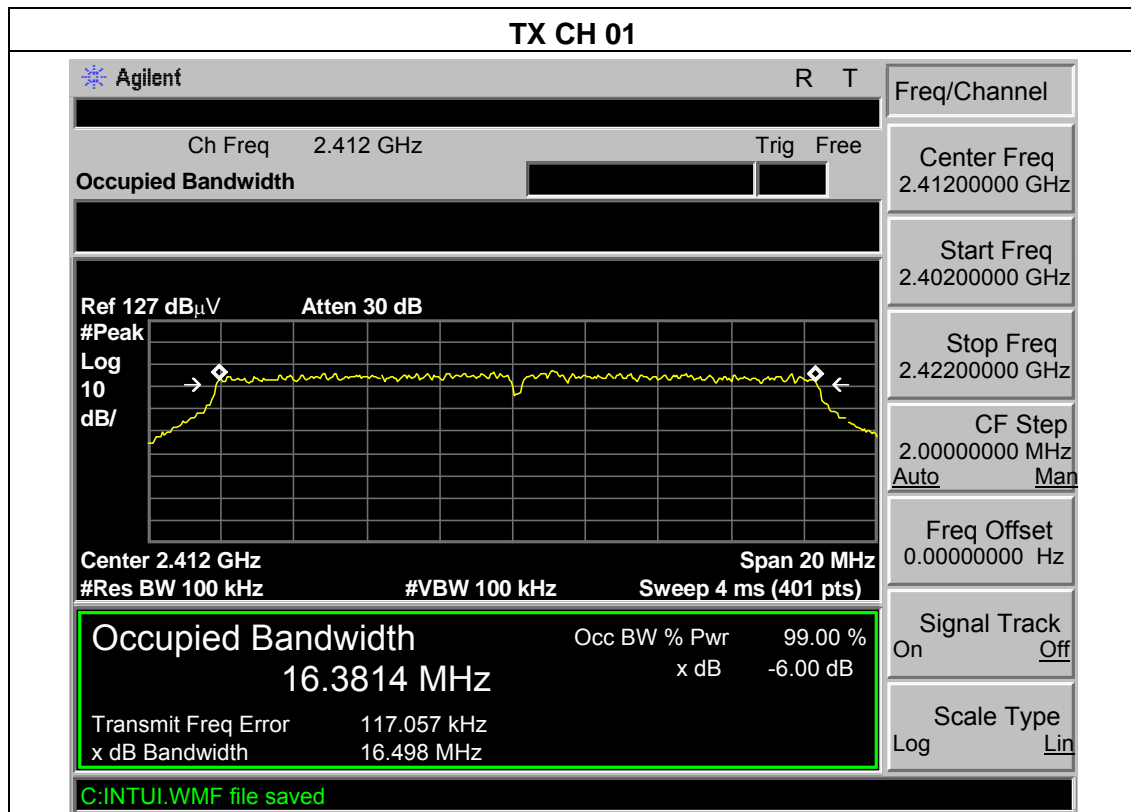

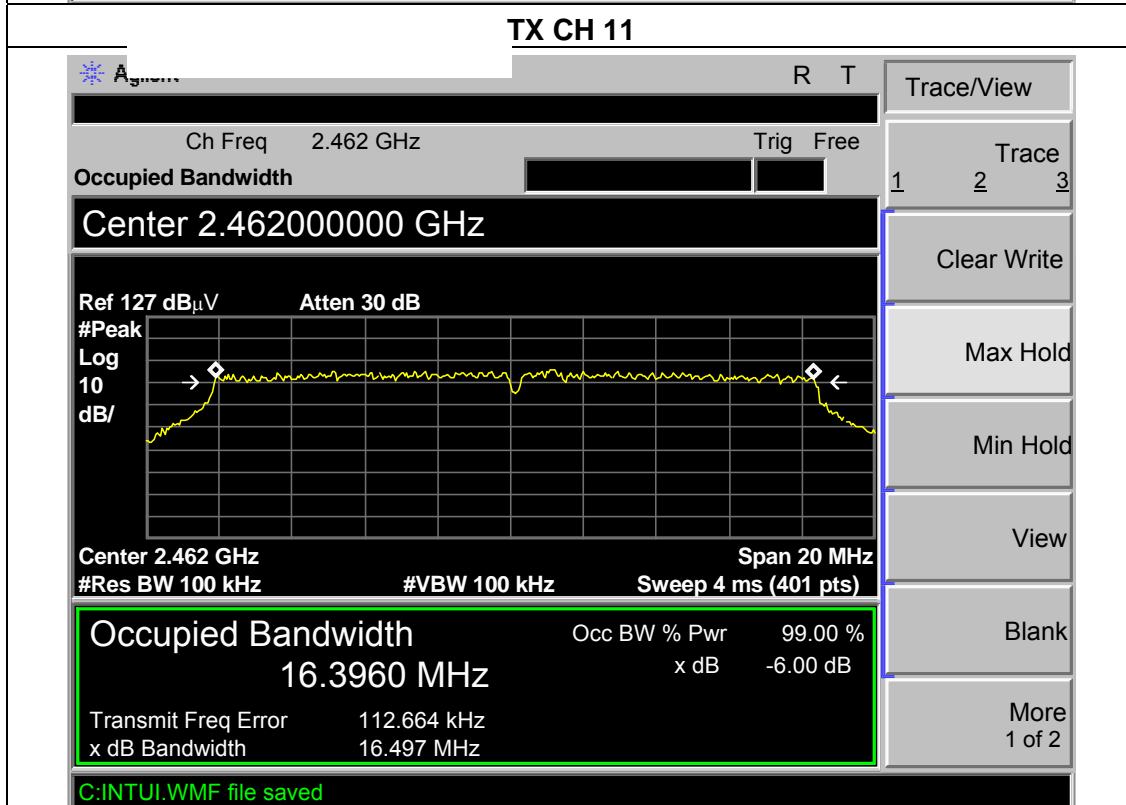
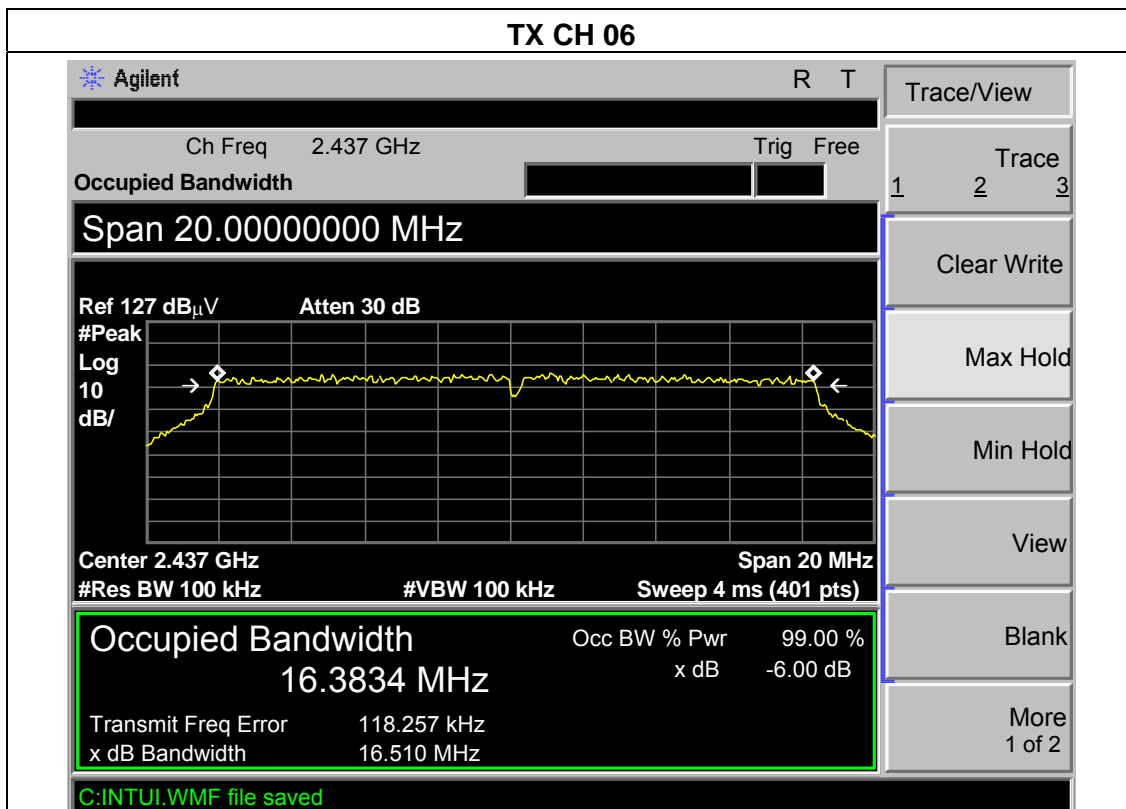

EUT :	Outdoor Long Range USB CPE with N male connector	Model Name :	TUBE-U(N)
Temperature :	25 °C	Relative Humidity :	60%
Pressure :	1012 hPa	Test Voltage :	DC5v from PC
Test Mode :	TX N MODE /CH01, CH06, CH11(40MHz)		

Frequency	6dB Bandwidth (MHz)	99% Occupied BW (MHz)	Channel Separation (MHz)	Result
2422 MHz	36.44	36.07	>=500KHz	<b>PASS</b>
2452 MHz	36.43	35.83	>=500KHz	<b>PASS</b>

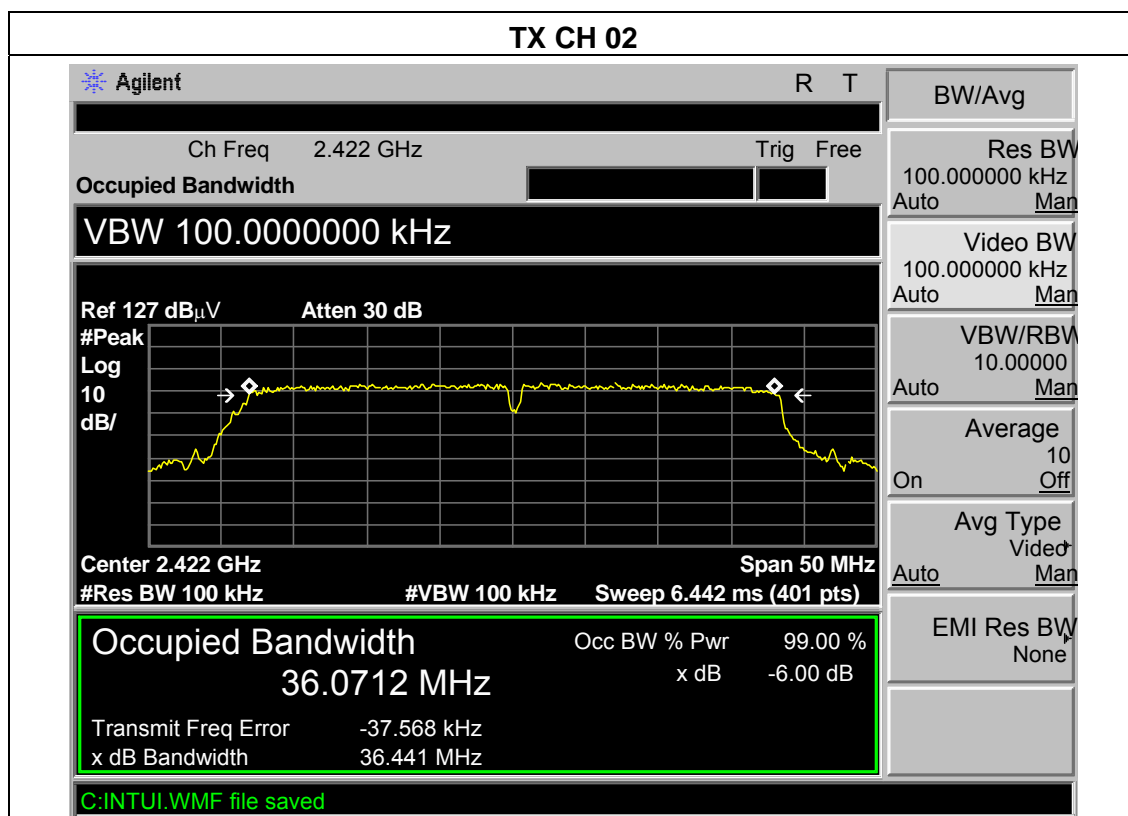

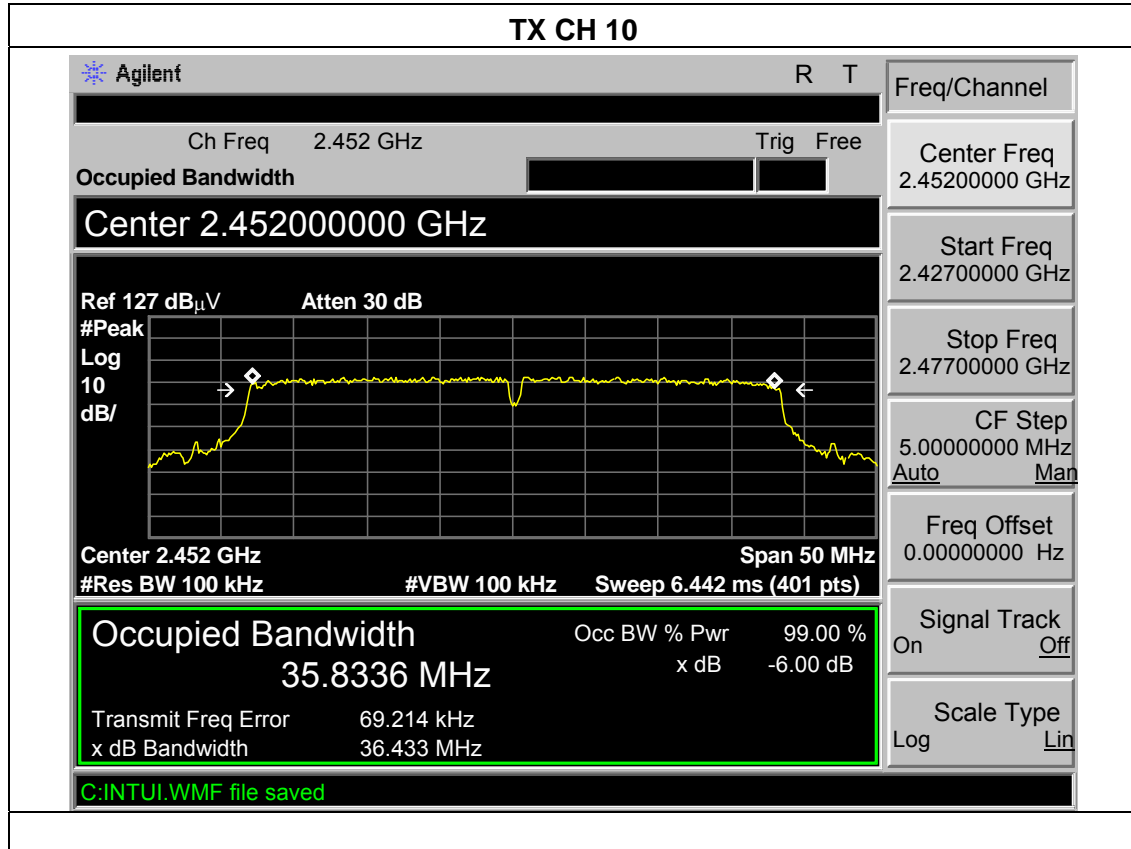

## 6. PEAK OUTPUT POWER TEST

### 6.1 APPLIED PROCEDURES / LIMIT

FCC Part15 (15.247) , Subpart C & RSS-210 Annex 8				
Section	Test Item	Limit	Frequency Range (MHz)	Result
15.247 (b)(1) & A8.4	Peak Output Power	1 watt or 30dBm	2400-2483.5	PASS

#### 6.1.1 TEST PROCEDURE

- a. The EUT was directly connected to the Power meter

#### 6.1.2 DEVIATION FROM STANDARD

No deviation.

#### 6.1.3 TEST SETUP



#### 6.1.4 EUT OPERATION CONDITIONS

The EUT tested system was configured as the statements of 4.1.6 Unless otherwise a special operating condition is specified in the follows during the testing.

**6.1.5 TEST RESULTS**

EUT :	Outdoor Long Range USB CPE with N male connector	Model Name :	TUBE-U(N)
Temperature :	25 °C	Relative Humidity :	60%
Pressure :	1012 hPa	Test Voltage :	DC5V from PC
Test Mode :	TX B MODE /CH01, CH06, CH11		

Test Channel	Frequency (MHz)	Average output power (dBm)	LIMIT (dBm)	LIMIT (W)
CH01	2412	26.71	30	1
CH06	2437	26.32	30	1
CH11	2462	26.34	30	1

EUT :	Outdoor Long Range USB CPE with N male connector	Model Name :	TUBE-U(N)
Temperature :	25 °C	Relative Humidity :	60%
Pressure :	1012 hPa	Test Voltage :	DC5V from PC
Test Mode :	TX G MODE /CH01, CH06, CH11		

Test Channel	Frequency (MHz)	Average output power (dBm)	LIMIT (dBm)	LIMIT (W)
CH01	2412	25.57	30	1
CH06	2437	25.56	30	1
CH11	2462	25.14	30	1

EUT :	Outdoor Long Range USB CPE with N male connector	Model Name :	TUBE-U(N)
Temperature :	25 °C	Relative Humidity :	60%
Pressure :	1012 hPa	Test Voltage :	DC5V from PC
Test Mode :	TX N MODE /CH01, CH06, CH11(20MHz)		

Test Channel	Frequency (MHz)	Average output power (dBm)	LIMIT (dBm)	LIMIT (W)
CH01	2412	25.55	30	1
CH06	2437	25.51	30	1
CH11	2462	25.32	30	1



EUT :	Outdoor Long Range USB CPE with N male connector	Model Name :	TUBE-U(N)
Temperature :	25 °C	Relative Humidity :	60%
Pressure :	1012 hPa	Test Voltage :	DC5V from PC
Test Mode :	TX N MODE /CH01, CH06, CH11(40MHz)		

Test Channel	Frequency (MHz)	Average output power (dBm)	LIMIT (dBm)	LIMIT (W)
CH02	2422	25.17	30	1
CH06	2437	25.99	30	1
CH10	2452	25.12	30	1

## 7. ANTENNA CONDUCTED SPURIOUS EMISSION

### 7.1 APPLIED PROCEDURES / LIMIT

20dBc in any 100 kHz bandwidth outside the operating frequency band. In case the emission fall within the restricted band specified on 15.205(a), then the 15.209(a) limit in the table below has to be followed.

Frequencies (MHz)	Field Strength (micorvolts/meter)	Measurement Distance (meters)
0.009~0.490	2400/F(KHz)	300
0.490~1.705	24000/F(KHz)	30
1.705~30.0	30	30
30~88	100	3
88~216	150	3
216~960	200	3
Above 960	500	3

The following table is the setting of the spectrum analyzer.

Spectrum Parameter	Setting
Attenuation	Auto
Span Frequency	100 MHz
RB / VB (emission in restricted band)	1MHz / 1MHz for Peak, 1 MHz / 10Hz for Average
RB / VB (other emission)	100 KHz /100 KHz for Peak

#### 7.1.1 TEST PROCEDURE

- a. The EUT was directly connected to the spectrum analyzer and antenna output port as show in the block diagram below,
- b. Spectrum Setting : RBW= 100KHz, VBW=100KHz, Sweep time = Auto.

#### 7.1.2 DEVIATION FROM STANDARD

No deviation.

### 7.1.3 TEST SETUP



### 7.1.4 EUT OPERATION CONDITIONS

The EUT tested system was configured as the statements of 4.1.6 Unless otherwise a special operating condition is specified in the follows during the testing.

### 7.1.5 TEST RESULTS

EUT :	Outdoor Long Range USB CPE with N male connector	Model Name :	TUBE-U(N)
Temperature :	25 °C	Relative Humidity :	60%
Pressure :	1012 hPa	Test Voltage :	DC5v from PC
Test Mode :	TX B MODE /CH01, CH11		

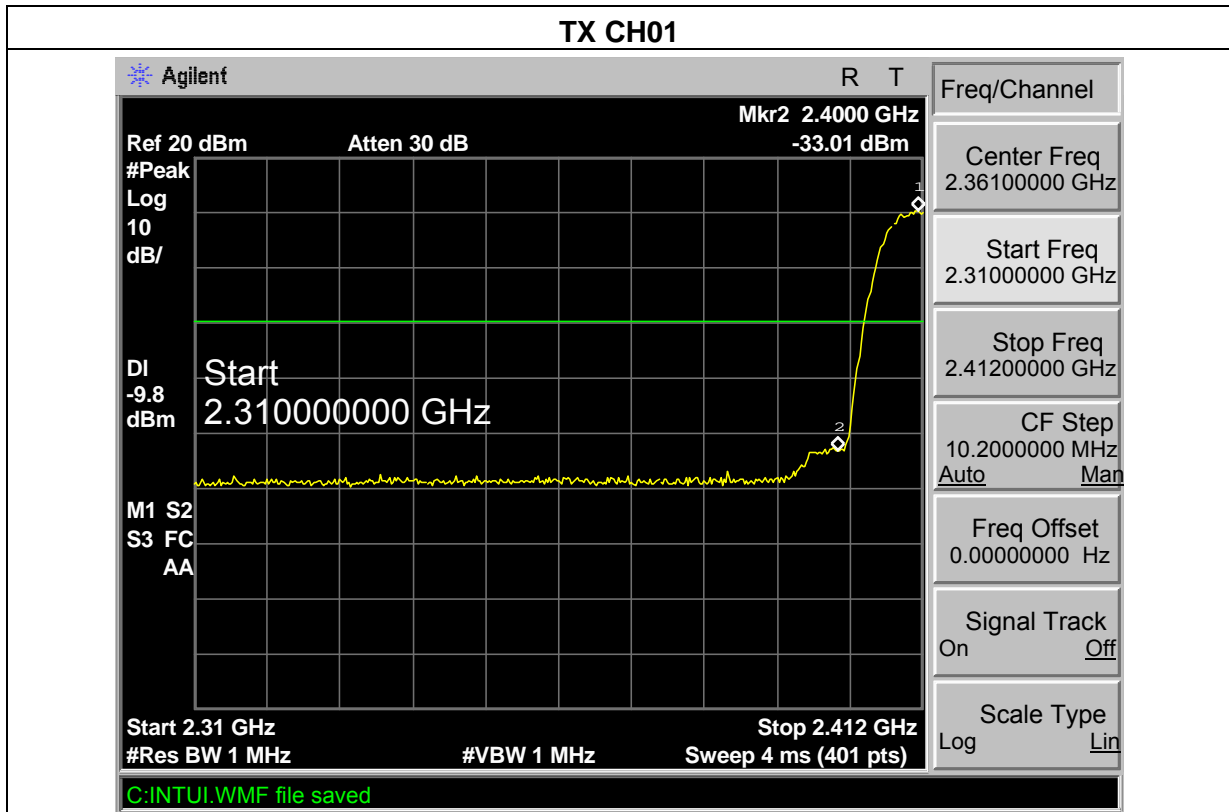

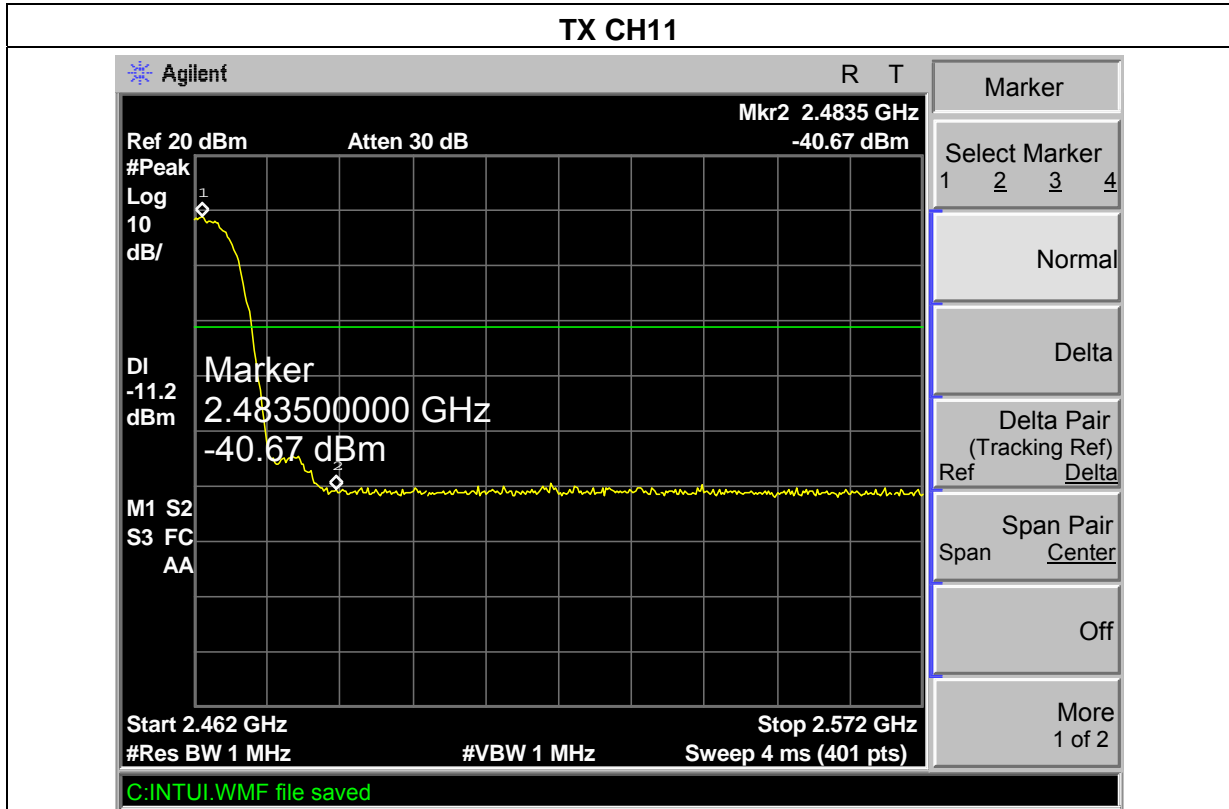

EUT :	Outdoor Long Range USB CPE with N male connector	Model Name :	TUBE-U(N)
Temperature :	25 °C	Relative Humidity :	60%
Pressure :	1012 hPa	Test Voltage :	DC 5V from PC
Test Mode :	TX G MODE /CH01, CH11		

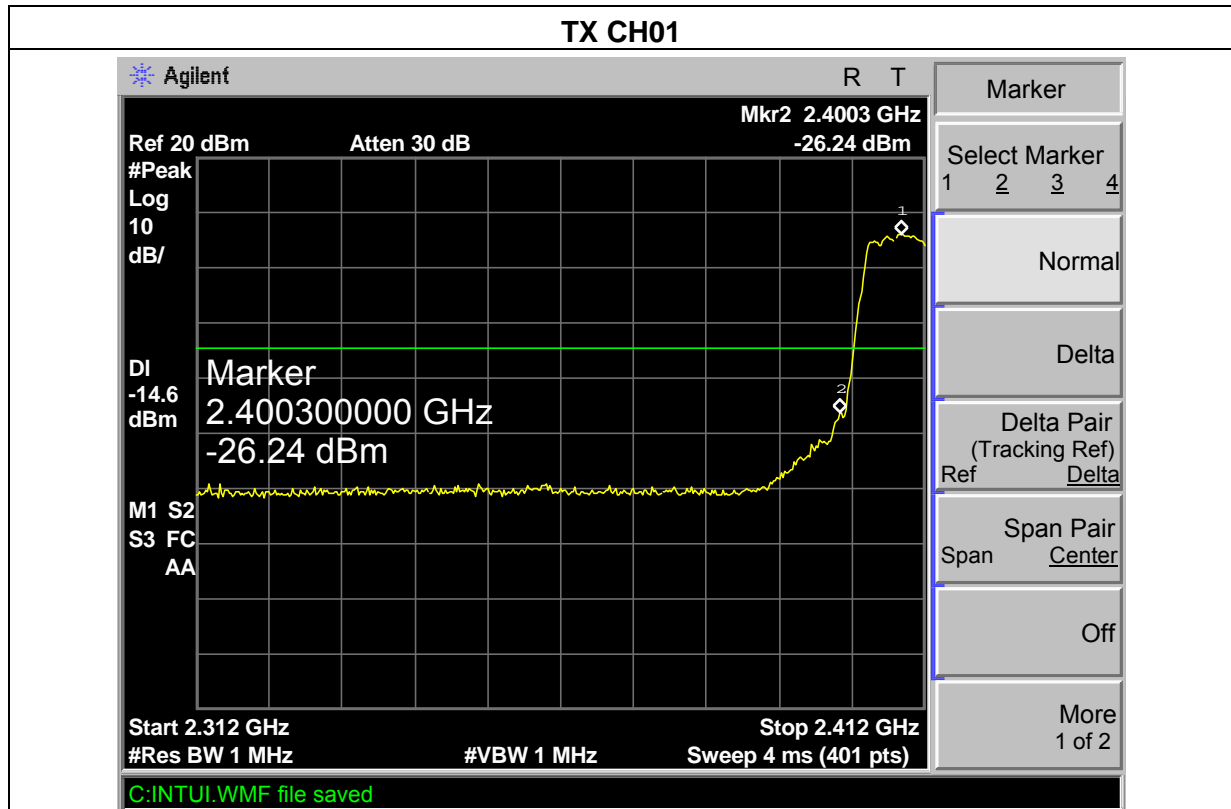

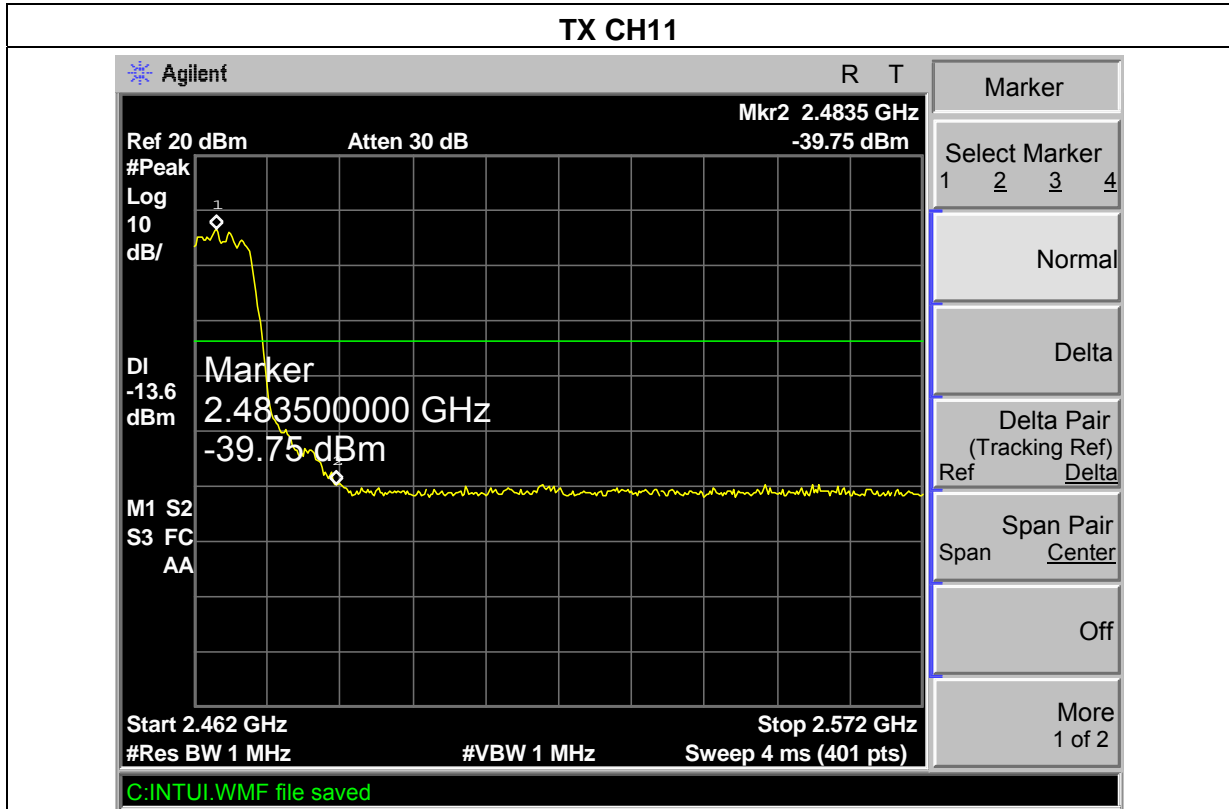

EUT :	Outdoor Long Range USB CPE with N male connector	Model Name :	TUBE-U(N)
Temperature :	25 °C	Relative Humidity :	60%
Pressure :	1012 hPa	Test Voltage :	DC 5V from PC
Test Mode :	TX N MODE /CH01, CH11(20MHz)		

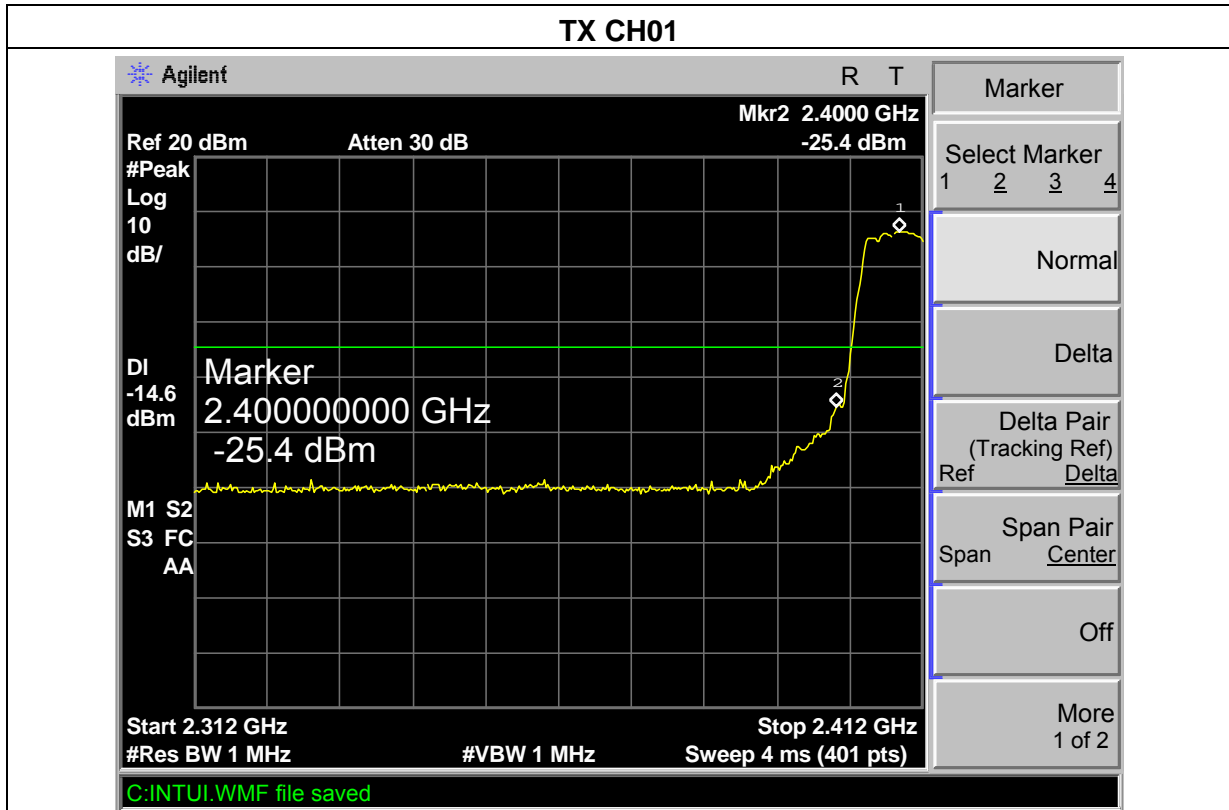



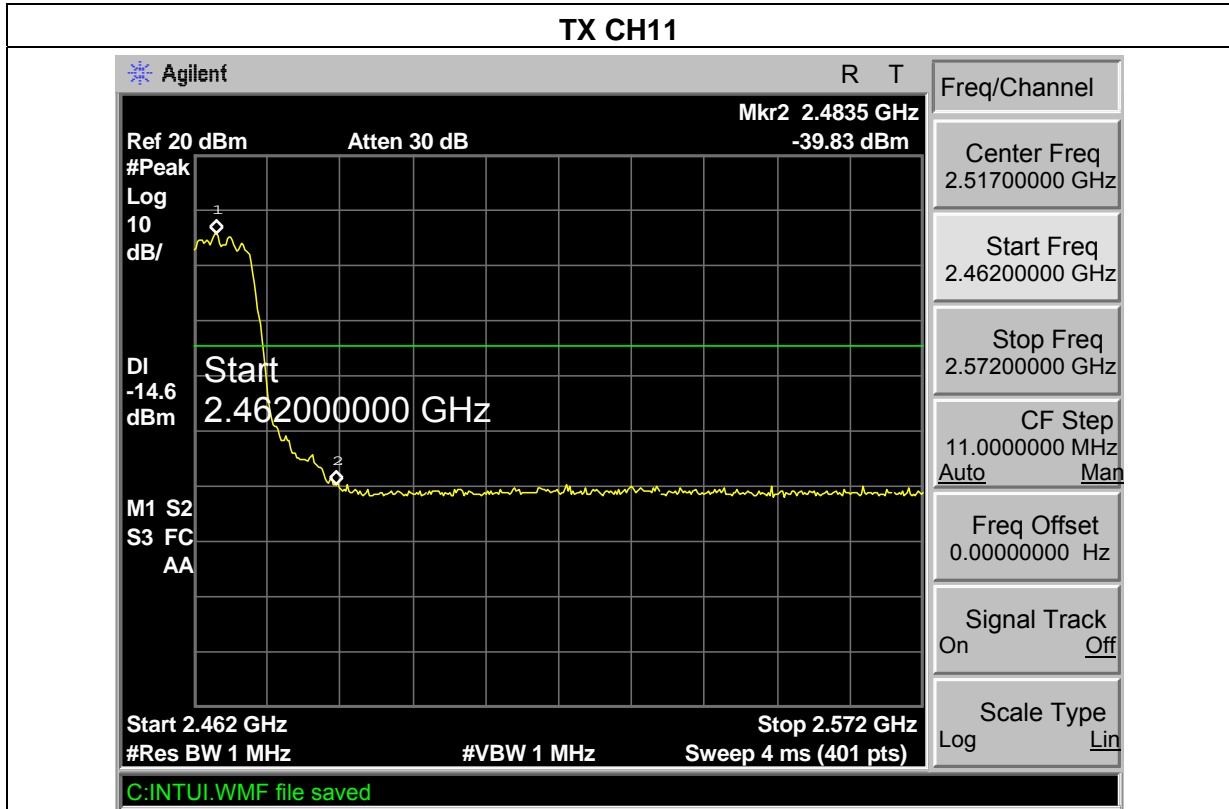

EUT :	Outdoor Long Range USB CPE with N male connector	Model Name :	TUBE-U(N)
Temperature :	25 °C	Relative Humidity :	60%
Pressure :	1012 hPa	Test Voltage :	DC5V from PC
Test Mode :	TX N MODE /CH01, CH11(40MHz)		

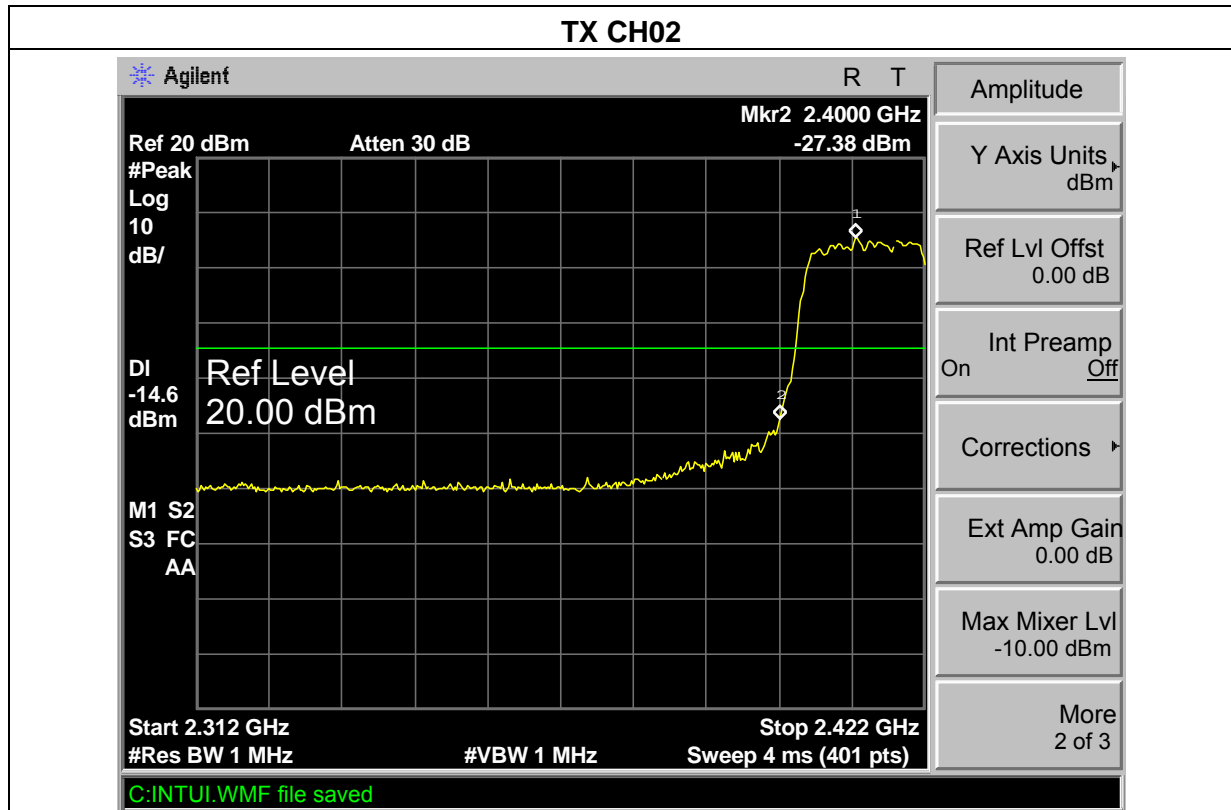

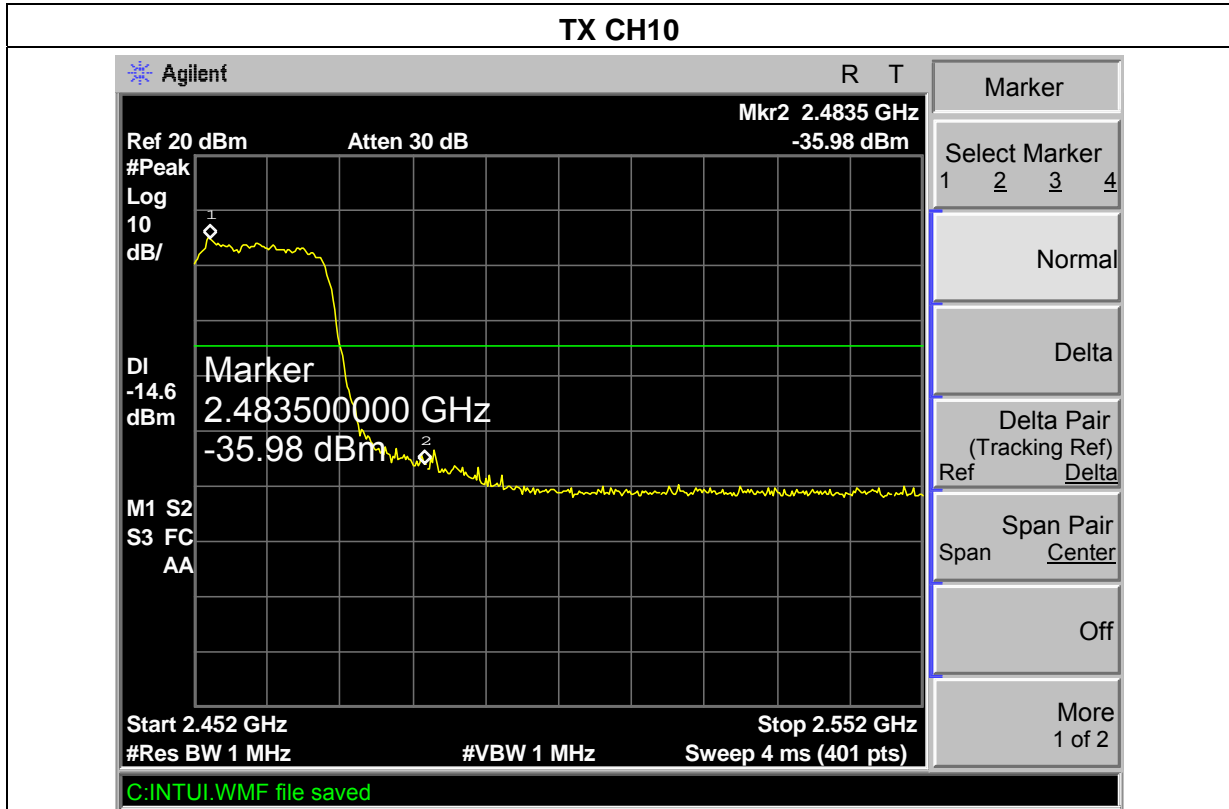

## 8. RF EXPOSURE TEST

### 8.1 APPLIED PROCEDURES / LIMIT

These devices are not exempted from compliance does not exceed the Commission’s RF exposure guidelines. Unless a device operates at substantially low power levels, with a low gain antenna(s), supporting information is generally needed to establish the various potential operating configurations and exposure conditions of a transmitter and its antenna(s) in order to determine compliance with the RF exposure guidelines.

In order to demonstrate compliance with MPE requirement (see Section 2.1091), the following information is typically needed:

Calculation that estimates the minimum separation distance (20 cm or more) between an antenna and persons required to satisfy power density limits defined for free space.

Antenna installation and device operating instructions for installers (professional/unskilled users), and the parties responsible for ensuring compliance with the RF exposure requirement. Any caution statements and/or warning labels that are necessary in order to comply with the exposure limits. Any other RF exposure related issues that may affect MPE compliance.

FCC 1.1310: The criteria listed in the following table shall be used to evaluate the environmental impact of human exposure to radio-frequency (RF) radiation as specified in 1.1307(b).

#### (A) Limits for Occupational / Controlled Exposure

Frequency Range (MHz)	Electric Field Strength (E) (V/m)	Magnetic Field Strength (H) (A/m)	Power Density (S) (mW/cm <sup>2</sup> )	Averaging Time  E  <sup>2</sup> ,  H  <sup>2</sup> or S (minutes)
0.3-3.0	614	1.63	(100)*	6
3.0-30	1842 / f	4.89 / f	(900 / f)*	6
30-300	61.4	0.163	1.0	6
300-1500			F/300	6
1500-100,000			5	6

#### (B) Limits for General Population / Uncontrolled Exposure

Frequency Range (MHz)	Electric Field Strength (E) (V/m)	Magnetic Field Strength (H) (A/m)	Power Density (S) (mW/cm <sup>2</sup> )	Averaging Time  E  <sup>2</sup> ,  H  <sup>2</sup> or S (minutes)
0.3-1.34	614	1.63	(100)*	30
1.34-30	824/f	2.19/f	(180/f)*	30
30-300	27.5	0.073	0.2	30
300-1500			F/1500	30
1500-100,000			1.0	30

Note: f = frequency in MHz ; \*Plane-wave equivalent power density

### 8.1.1 MPE CALCULATION METHOD

Calculation Method of RF Safety Distance:

$$S = \frac{PG}{4\pi r^2} = \frac{EIRP}{4\pi r^2}$$

P :power input to the antenna in Mw

EIRP :Equivalent(effective) isotropic radiated power.

S :power density mW/ cm<sup>2</sup>

G ;numeric gain of antenna relative to isotropic radiator

R :distance to centre of radiation in cm

FCC radio frequency exposure limits may be exceeded at distances closer than r cm from the antenna of this device

$$r = \sqrt{\frac{PG}{4\pi S}} = \sqrt{\frac{EIRP}{4\pi S}}$$

EIRP=10<sup>(Antenna Gain+Peak Output Power/10)</sup>

Note:

1. s=1.0 mW /cm<sup>2</sup> for limits for General Population/Uncontrolled Exposures.
2. The time averaged power over 30 minutes will be equaled Output Power.
3. Minimum calculated separation distance between antenna and persons required:0.53 cm
4. The Power Density at a distance of 20cm calculated from the formula is far below the limit of 1MW/ cm<sup>2</sup>
5. For portable device,the power limit is 60/f(in GHz) mW

### 8.1.2 TEST RESULTS

EUT :	Outdoor Long Range USB CPE with N male connector	Model Name :	TUBE-U(N)
Temperature :	25 °C	Relative Humidity :	60%
Pressure :	1012 hPa	Test Voltage :	DC5V from PC
Test Mode :	TX Mode		

Operating Mode:802.11 b

Channel (MHz)	Average output power (dBm)	Power Density (S) (mW/ cm2)	Limit of Power Density (S) (mW/ cm2)	Result
2412	26.71	0.100G	1	Pass
2437	26.32	0.F€JJ	1	Pass
2462	26.34	0.FF€4	1	Pass

Operating Mode:802.11 g

Channel (MHz)	Average output power (dBm)	Power Density (S) (mW/ cm2)	Limit of Power Density (S) (mW/ cm2)	Result
2412	25.57	0.€JG	1	Pass
2437	25.56	0.0922	1	Pass
2462	25.14	0.0837	1	Pass

Operating Mode:802.11 N(20MHz)

Channel (MHz)	Average output power (dBm)	Power Density (S) (mW/ cm2)	Limit of Power Density (S) (mW/ cm2)	Result
2412	25.55	0.0920	1	Pass
2437	25.51	0.0912	1	Pass
2462	25.32	0.0873	1	Pass

Operating Mode:802.11 N (40MHz)

<b>Channel (MHz)</b>	<b>Average output power (dBm)</b>	<b>Power Density (S) (mW/ cm<sup>2</sup>)</b>	<b>Limit of Power Density (S) (mW/ cm<sup>2</sup>)</b>	<b>Result</b>
2422	25.17	0.0843	1	Pass
2437	25.99	0.1018	1	Pass
2452	25.12	0.0833	1	Pass

## 9. EUT TEST PHOTO

### Radiated Measurement Photos



### Conducted Measurement Photos





