

Model Name		Rev
		R01
Size	Page Name	Engineer
C		
Date:	Thursday, February 09, 2012	Sheet 5 of 12

VDD25
VDD33

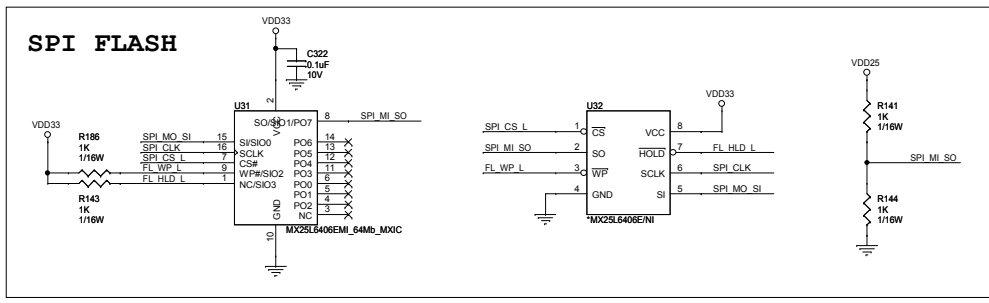

Model Name		Rev
		R01
Size	Page Name	Engineer
C		
Date:	Thursday, February 09, 2012	Sheet 6 of 12

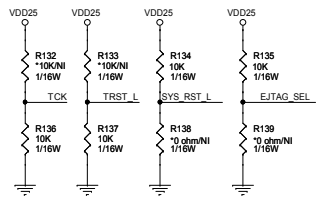
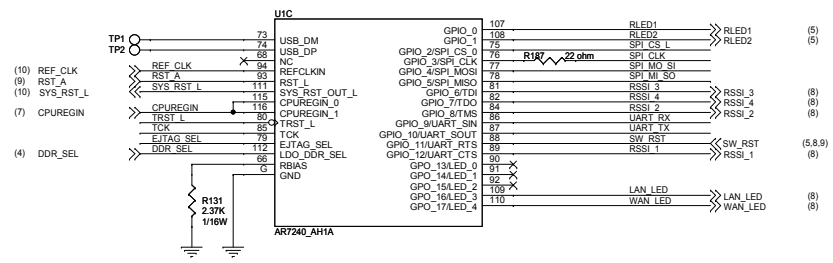
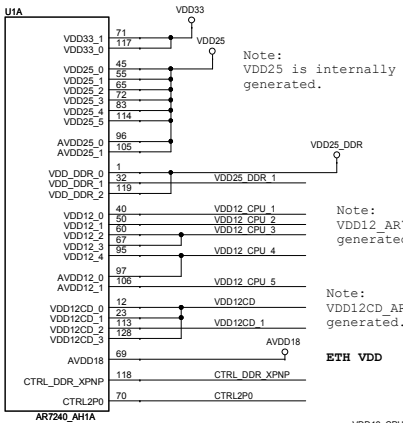

Note:
VDD25 is internally generated.

Note:
VDD12_AR7240 is internally generated.

Note:
VDD12CD_AR7240 is internally generated.

ETH VDD

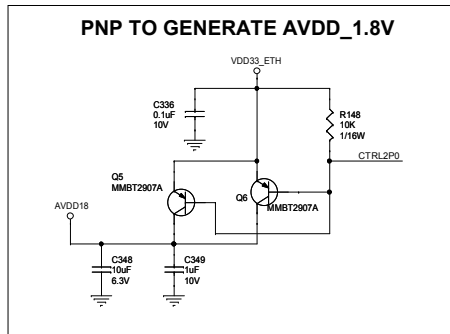
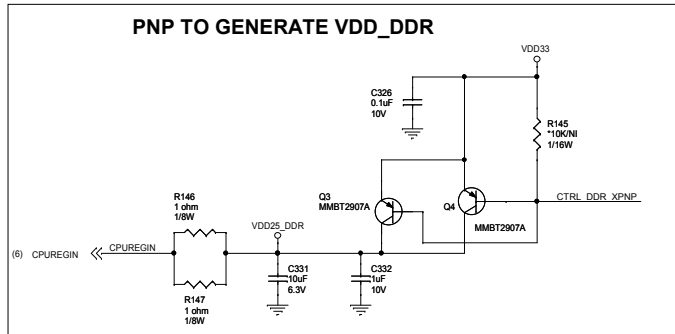
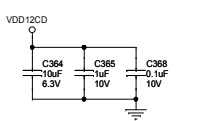
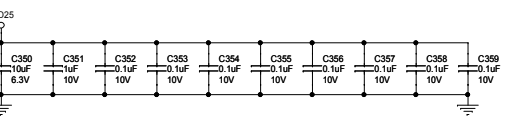
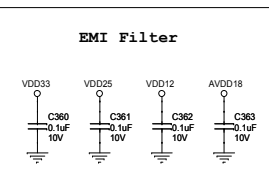
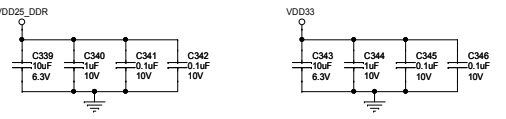
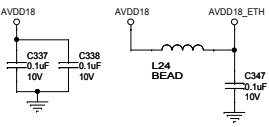
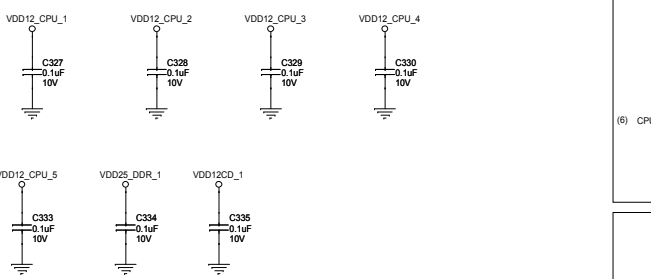

Model Name		Rev
		R01
Size	Page Name	Engineer
C		
Date:	Thursday, February 09, 2012	Sheet 7 of 12

LED

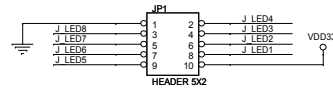
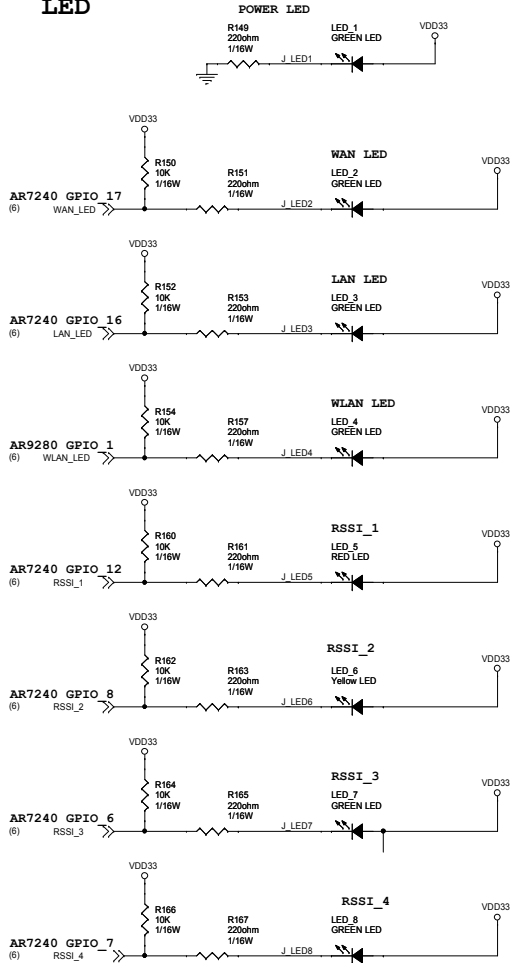

FACTORY DEFAULT/ SOFTWARE RESET

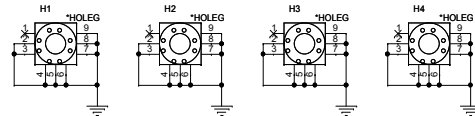
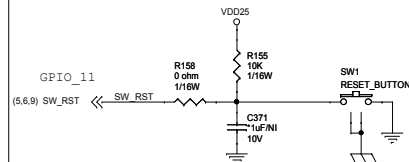

Model Name		Rev
		R01
Size	Page Name	Engineer
C		
Date:	Thursday, February 09, 2012	Sheet 8 of 12

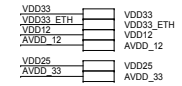
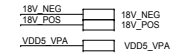
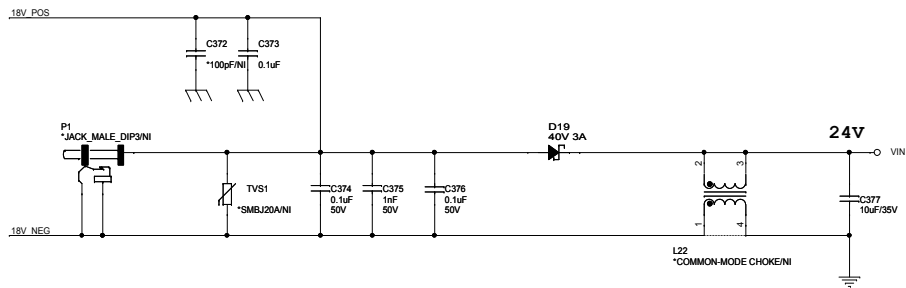

Layout Aspect References

VDD5_VPA = 0.6A (PA)
 3.3V = 0.345A
 2.5V = 0.23A
 1.2V = 0.41A

GND Isolated

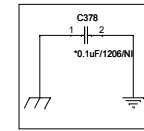

8~24V -> 5V, I_{max}=3A V_{out} = 0.925*(68K+15K/15K) = 5.118V

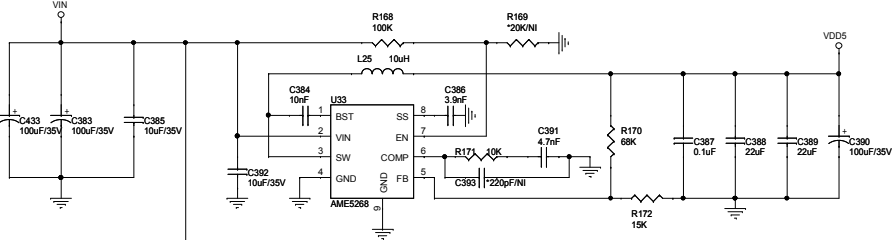

Note:
 5V_VPA is used for PA VDD.

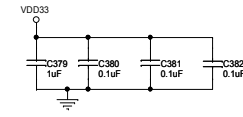
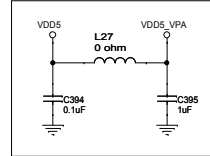

3.3V -> 1.2V, I_{max}=600mA

8~24V -> 3.3V, I_{max}=3A V_{out} = 0.925*(39K+15K/15K) = 3.33V

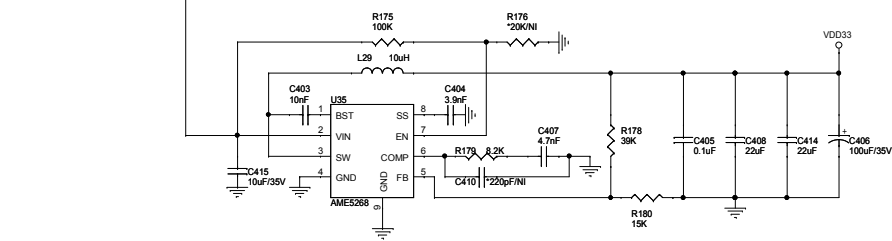

Note:
 VDD12_RF is used for AR9283.

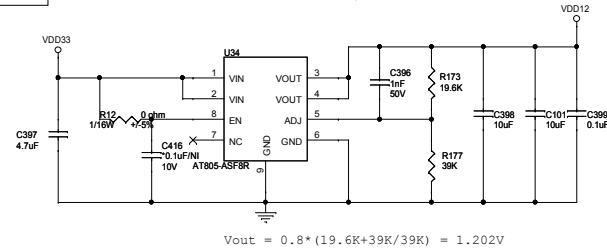
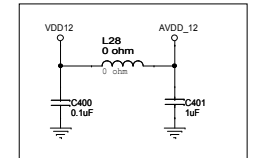

V_{out} = 0.8*(19.6K+39K/39K) = 1.202V

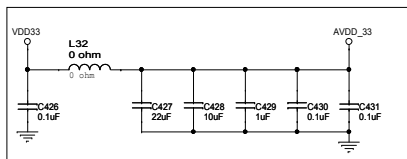
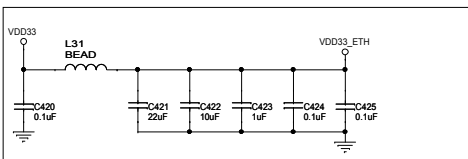

Model Name		Rev
		R01
Size	Page Name	Engineer
C		
Date:	Thursday, February 09, 2012	Sheet 8 of 12

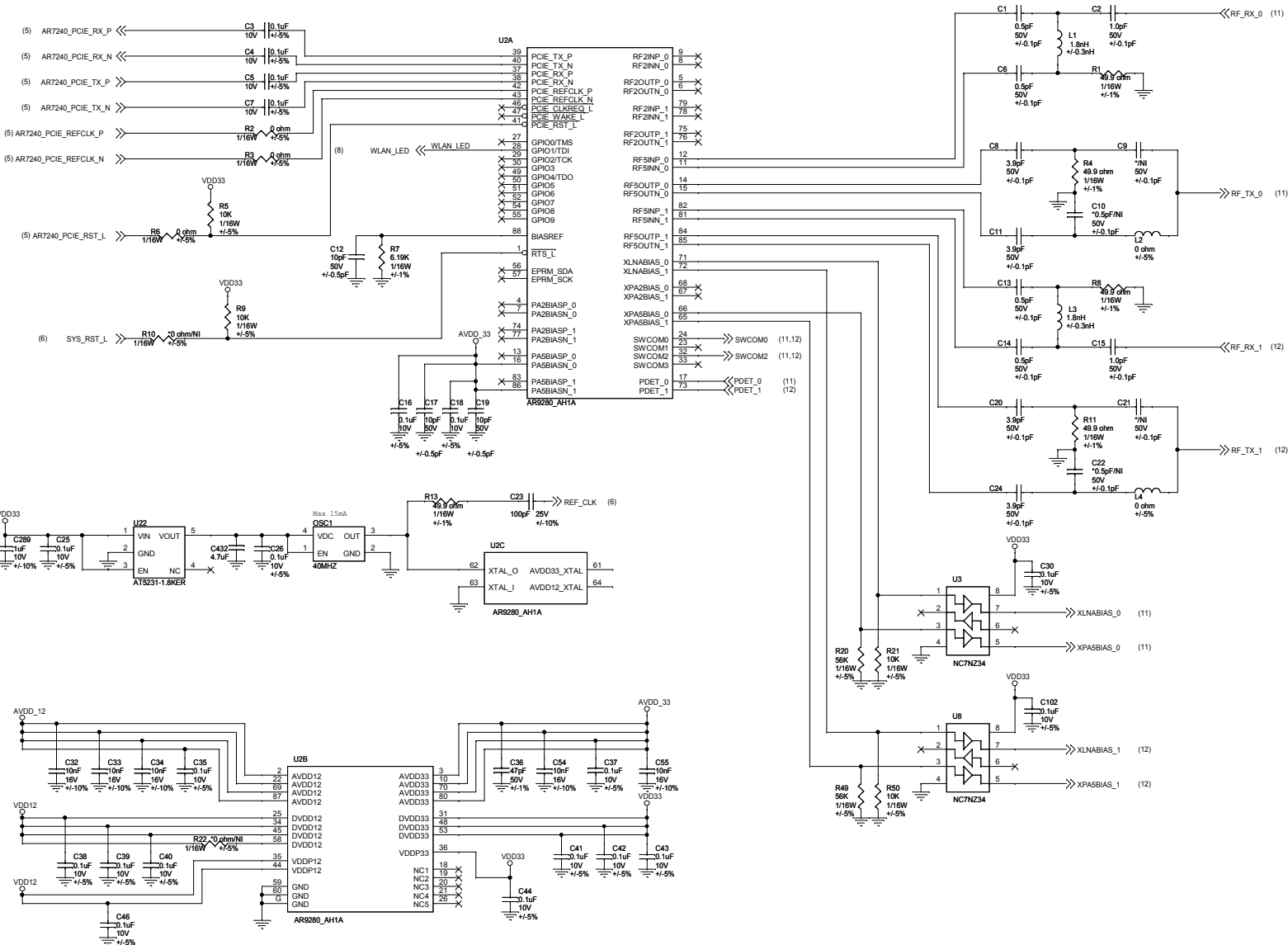

Model Name		Rev
		R01
Size	Page Name	Engineer
C		
Date:	Thursday, February 09, 2012	Sheet 10 of 12

