

FCC RADIO TEST REPORT

Report Reference No. : NTEK-2011NT12091126E

Compiled by (+ signature) : Tom Zhang

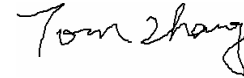

Approved by (+ signature) : Bovey Yang



Applicant's name : ALFA NETWORK Inc.

Address..... : 4F-1 No.106, Rueiguang Rd., Neihu Distric, Taipei City 114

Manufacture's Name : ALFA NETWORK Inc.

Address..... : 4F-1 No.106, Rueiguang Rd., Neihu Distric, Taipei City 114

Test specification:

Standard : FCC Part15.247

Test procedure : ANSI C63.4-2003

Test item description

Product name : IEEE 802.11b/g/n Long Range AP-Router

FCC ID : UQ2525H

Trademark : ALFA

Model and/or type reference : AIP-W525H, AIP-W515H, W525H, W515H, G2N, G2NH, AWAP02O-15H, AWAP02O-25H

Rating(s) : DC 12V, 300mA, 3.6W

Testing Laboratory information:

Testing Laboratory Name : NTEK Testing Technology Co., Ltd

Address : 1/F, Building E, Fenda Science Park, Sanwei Community, Xixiang Street, Bao ' an District, Shenzhen P.R. China.

This device described above has been tested by NTEK Testing Technology Co., Ltd, and the test results show that the equipment under test (EUT) is in compliance with the FCC requirements. And it is applicable only to the tested sample identified in the report.

This report shall not be reproduced except in full, without the written approval of NTEK Testing Technology Co., Ltd, this document may be altered or revised by NTEK Testing Technology Co., Ltd, personal only, and shall be noted in the revision of the documen

Testing

Date of receipt of test item : 1 Dec. 2011

Date (s) of performance of tests : 1 Dec. 2011 ~7 Dec. 2011

Date of Issue..... : 7 Dec. 2011

Test Result..... : **Pass**

Table of Contents

	Page
1 . SUMMARY OF TEST RESULTS	4
1.1 TEST FACILITY	5
1.2 MEASUREMENT UNCERTAINTY	5
2 . GENERAL INFORMATION	6
2.1 GENERAL DESCRIPTION OF EUT	6
2.2 DESCRIPTION OF TEST MODES	8
2.3 TABLE OF PARAMETERS OF TEXT SOFTWARE SETTING	8
2.4 BLOCK DIGRAM SHOWING THE CONFIGURATION OF SYSTEM TESTED	9
2.5 DESCRIPTION OF SUPPORT UNITS(CONDUCTED MODE)	10
2.6 EQUIPMENTS LIST FOR ALL TEST ITEMS	11
3 . EMC EMISSION TEST	12
3.1 CONDUCTED EMISSION MEASUREMENT	12
3.1.1 POWER LINE CONDUCTED EMISSION LIMITS	12
3.1.2 TEST PROCEDURE	13
3.1.3 DEVIATION FROM TEST STANDARD	13
3.1.4 TEST SETUP	13
3.1.5 EUT OPERATING CONDITIONS	13
3.1.6 TEST RESULTS	14
3.2 RADIATED EMISSION MEASUREMENT	16
3.2.1 RADIATED EMISSION LIMITS	16
3.2.2 TEST PROCEDURE	17
3.2.3 DEVIATION FROM TEST STANDARD	17
3.2.4 TEST SETUP	18
3.2.5 EUT OPERATING CONDITIONS	19
3.2.6 TEST RESULTS (BETWEEN 9KHZ – 30 MHZ)	20
3.2.7 TEST RESULTS (BETWEEN 30MHZ – 1GHZ)	21
3.2.8 TEST RESULTS (ABOVE 1000 MHZ)	23
4 .BAND EDGE EMISSION	47
5 . POWER SPECTRAL DENSITY TEST	63
5.1 APPLIED PROCEDURES / LIMIT	63
5.1.1 TEST PROCEDURE	63
5.1.2 DEVIATION FROM STANDARD	63
5.1.3 TEST SETUP	63
5.1.4 EUT OPERATION CONDITIONS	63
5.1.5 TEST RESULTS	64

Table of Contents

	Page
6 . BANDWIDTH TEST	72
6.1 APPLIED PROCEDURES / LIMIT	72
6.1.1 TEST PROCEDURE	72
6.1.2 DEVIATION FROM STANDARD	72
6.1.3 TEST SETUP	72
6.1.4 EUT OPERATION CONDITIONS	72
6.1.5 TEST RESULTS	73
7 . PEAK OUTPUT POWER TEST	81
7.1 APPLIED PROCEDURES / LIMIT	81
7.1.1 TEST PROCEDURE	81
7.1.2 DEVIATION FROM STANDARD	81
7.1.3 TEST SETUP	81
7.1.4 EUT OPERATION CONDITIONS	81
7.1.5 TEST RESULTS	82
8 . EUT TEST PHOTO	86
APPENDIX-PHOTOGRAPHS OF EUT CONSTRUCTIONAL DETAILS	

1. SUMMARY OF TEST RESULTS

Test procedures according to the technical standards:

FCC Part15 (15.247) , Subpart C			
Standard Section	Test Item	Judgment	Remark
15.207	Conducted Emission	PASS	
15.247 (a)(2)	6dB Bandwidth	PASS	
15.247 (b)	Peak Output Power	PASS	
15.247 (c)	Radiated Spurious Emission	PASS	
15.247 (d)	Power Spectral Density	PASS	
15.203	Antenna Requirement	PASS	

1.1 TEST FACILITY

NTEK Testing Technology Co., Ltd

Add. : 1/F, Building E, Fenda Science Park, Sanwei Community, Xixiang Street, Bao'an District, Shenzhen P.R. China.

FCC FRN Registration Nombre:238937; IC Registration Nombre:9270A-1

1.2 MEASUREMENT UNCERTAINTY

The reported uncertainty of measurement $y \pm U$, where expanded uncertainty U is based on a standard uncertainty multiplied by a coverage factor of $k=2$, providing a level of confidence of approximately **95 %**.

No.	Item	Uncertainty
1	Conducted Emission Test	$\pm 1.38\text{dB}$
2	Radiated Emission Test	$\pm 3.17\text{dB}$
3	RF power,conducted	$\pm 0.16\text{dB}$
4	Spurious emissions,conducted	$\pm 0.21\text{dB}$
5	All emissions,radiated(<1G)	$\pm 4.68\text{dB}$
6	All emissions,radiated(>1G)	$\pm 4.89\text{dB}$

2. GENERAL INFORMATION

2.1 GENERAL DESCRIPTION OF EUT

Equipment	IEEE 802.11b/g/n Long Range AP-Router	
Trade Name	ALFA	
Model Name	AIP-W525H, AIP-W515H, W525H, W515H, G2N, G2NH, AWAP02O-15H, AWAP02O-25H	
OEM Brand/Model Name	N/A	
Model Difference	N/A	
Product Description	The EUT is a Travel Router	
	Operation Frequency:	802.11b/g/n(20MHz): 2412~2462 MHz 802.11n(40MHz):2422~2452 MHz
	Modulation Type:	CCK/OFDM/DBPSK/DAPSK
	Bit Rate of Transmitter	802.11b:11/5.5/2/1 Mbps 802.11g:54/48/36/24/18/12/9/6 Mbps 802.11n(20MHz):54/144.44/130/117/115.56/104/86.67/78/52/6.5 Mbps 802.11n(40MHz):300/270/240/180/150/120/108/90/54 Mbps
	Number Of Channel	11 CH, Please see Note 2.
	Antenna Designation:	Please see Note 3.
	Antenna Gain(Peak)	Please see Note 3.
	Output Power(EIRP):	802.11b(A): 23.01 dBm (Max.) 802.11g (A): 26.17 dBm (Max.) 802.11n(20M) : 28.88 dBm (Max.) 802.11n (40M): 28.89 dBm (Max.)
	Based on the application, features, or specification exhibited in User's Manual, the EUT is considered as an ITE/Computing Device. More details of EUT technical specification, please refer to the User's Manual.	
	Channel List	Please refer to the Note 2.
Power Source	DC 12V	
Connecting I/O Port(s)	Please refer to the User's Manual	
Products Covered	N/A	

Note
:

1. For a more detailed features description, please refer to the manufacturer's specifications or the User's Manual.

2.

Channel List for 802.11b/g/n(20MHz)							
Channel	Frequency (MHz)	Channel	Frequency (MHz)	Channel	Frequency (MHz)	Channel	Frequency (MHz)
01	2412	04	2427	07	2442	10	2457
02	2417	05	2432	08	2447	11	2462
03	2422	06	2437	09	2452		

Channel List for 802.11b/g/n(40MHz)							
Channel	Frequency (MHz)	Channel	Frequency (MHz)	Channel	Frequency (MHz)	Channel	Frequency (MHz)
03	2422	06	2437	09	2452		
04	2427	07	2442				
05	2432	08	2447				

3.

Table for Filed Antenna

Ant	Brand	Model Name	Antenna Type	Connector	Gain (dBi)	NOTE
A	N/A	N/A	external Antenna	N/A	-1	Inverse spiral antenna
B	N/A	N/A	external Antenna	NA	-1	Inverse spiral antenna

The Control software(MP_TEST2.exe) can control antenna A and antenna B, For 802.11b/g mode, when antenna A is transmitting, antenna B closed, when antenna B is transmitting, antenna A closed. For 802.11n 20/40MHz mode ,two antennas simultaneously transmit. And the data is recorded for radiated emission.

2.2 DESCRIPTION OF TEST MODES

To investigate the maximum EMI emission characteristics generates from EUT, the test system was pre-scanning tested base on the consideration of following EUT operation mode or test configuration mode which possible have effect on EMI emission level. Each of these EUT operation mode(s) or test configuration mode(s) mentioned above was evaluated respectively.

Pretest Mode	Description
Mode 1	802.11b CH1/ CH6/ CH11
Mode 2	802.11g CH1/ CH6/ CH11
Mode 3	802.11n(20) CH1/ CH6/ CH11
Mode 4	802.11n(40) CH3/ CH6/ CH9

For Conducted Emission	
Final Test Mode	Description
Mode 5	NORMAL LINK

For Radiated Emission	
Final Test Mode	Description
Mode 1	802.11b CH1/ CH6/ CH11
Mode 2	802.11g CH1/ CH6/ CH11
Mode 3	802.11n(20) CH1/ CH6/ CH11
Mode 4	802.11n(40) CH3/ CH6/ CH9

Note:

- (1) The measurements are performed at the highest, middle, lowest available channels.
- (2) The measurements are performed at all Bit Rate of Transmitter, the worst data was reported

2.3 TABLE OF PARAMETERS OF TEXT SOFTWARE SETTING

During testing channel & power controlling software provided by the customer was used to control the operating channel as well as the output power level. The RF output power selection is for the setting of RF output power expected by the customer and is going to be fixed on the firmware of the final end product power parameters of WLAN

Test software Version	Test program: MP_TEST.exe		
802.11b	2412 MHz	2437 MHz	2462 MHz
802.11g	2412 MHz	2437 MHz	2462 MHz
802.11n(20MHz)	2412 MHz	2437 MHz	2462 MHz
802.11n(40MHz)	2422 MHz	2437 MHz	2452 MHz

2.4 BLOCK DIGRAM SHOWING THE CONFIGURATION OF SYSTEM TESTED

Radiated:

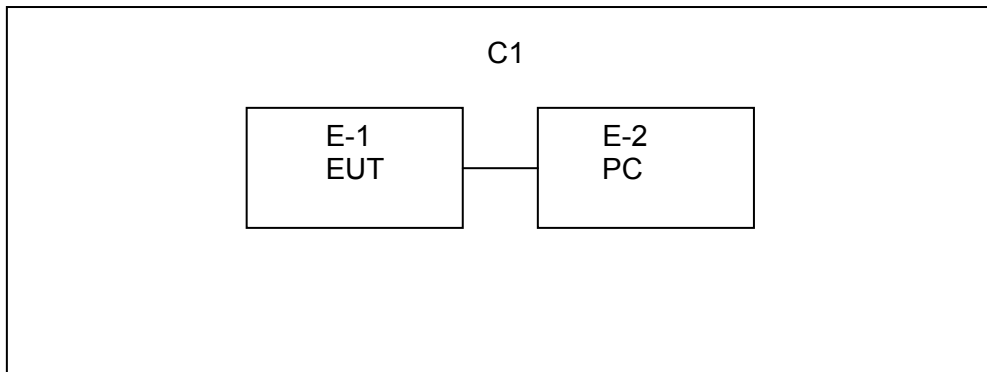

2.5 DESCRIPTION OF SUPPORT UNITS(CONDUCTED MODE)

The EUT has been tested as an independent unit together with other necessary accessories or support units. The following support units or accessories were used to form a representative test configuration during the tests.

Item	Equipment	Mfr/Brand	Model/Type No.	Series No.	Note
E-1	Travel Router	N/A	AIP-W525H	N/A	EUT
E-2	Notebook computer	IBM	2366	N/A	N/A

Item	Shielded Type	Ferrite Core	Length	Note
C1	NO	NO	0.5M	net cable

Note:

- (1) The support equipment was authorized by Declaration of Confirmation.
- (2) For detachable type I/O cable should be specified the length in cm in 『Length』 column.

2.6 EQUIPMENTS LIST FOR ALL TEST ITEMS

Radiation Test equipment

Item	Kind of Equipment	Manufacturer	Type No.	Serial No.	Calibrated until
1	Spectrum Analyzer	Agilent	E4407B	160400005	Jul. 06. 2012
2	Test Receiver	R&S	ESPI	101318	Jul. 06. 2012
3	Bilog Antenna	TESEQ	CBL6111D	31216	Jul. 06. 2012
4	50Ω Coaxial Switch	Anritsu	MP59B	6200264416	Jul. 06. 2012
5	Spectrum Analyzer	ADVANTEST	R3132	150900201	Jul. 06. 2012
6	Horn Antenna	EM	EM-AH-10180	2011071402	Jul. 06. 2012
7	Horn Ant	Schwarzbeck	BBHA 9170	9170-181	Jul. 06. 2012
8	Amplifier	EM	EM-30180	060538	Jul. 06. 2012
9	Loop Antenna	ARA	PLA-1030/B	1029	Jul. 06. 2012
10	Power Meter	R&S	NRVS	100696	Jul. 06. 2012

Conduction Test equipment

Item	Kind of Equipment	Manufacturer	Type No.	Serial No.	Calibrated until
1	Test Receiver	R&S	ESCI	101160	Jul. 06. 2012
2	LISN	R&S	ENV216	101313	Jul. 06. 2012
3	LISN	EMCO	3816/2	00042990	Jul. 06. 2012
4	50Ω Coaxial Switch	Anritsu	MP59B	6200264417	Jul. 06. 2012
5	Passive Voltage Probe	R&S	ESH2-Z3	100196	Jul. 06. 2012
6	Absorbing clamp	R&S	MOS-21	100423	Jul. 06. 2012

3. EMC EMISSION TEST

3.1 CONDUCTED EMISSION MEASUREMENT

3.1.1 POWER LINE CONDUCTED EMISSION Limits (Frequency Range 150KHz-30MHz)

FREQUENCY (MHz)	Class A (dBuV)		Class B (dBuV)		Standard
	Quasi-peak	Average	Quasi-peak	Average	
0.15 -0.5	79.00	66.00	66 - 56 *	56 - 46 *	CISPR
0.50 -5.0	73.00	60.00	56.00	46.00	CISPR
5.0 -30.0	73.00	60.00	60.00	50.00	CISPR

0.15 -0.5	79.00	66.00	66 - 56 *	56 - 46 *	FCC
0.50 -5.0	73.00	60.00	56.00	46.00	FCC
5.0 -30.0	73.00	60.00	60.00	50.00	FCC

Note:

- (1) The tighter limit applies at the band edges.
- (2) The limit of " * " marked band means the limitation decreases linearly with the logarithm of the frequency in the range.

The following table is the setting of the receiver

Receiver Parameters	Setting
Attenuation	10 dB
Start Frequency	0.15 MHz
Stop Frequency	30 MHz
IF Bandwidth	9 kHz

3.1.2 TEST PROCEDURE

- The EUT was placed 0.4 meters from the horizontal ground plane with EUT being connected to the power mains through a line impedance stabilization network (LISN). All other support equipments powered from additional LISN(s). The LISN provide 50 Ohm/ 50uH of coupling impedance for the measuring instrument.
- Interconnecting cables that hang closer than 40 cm to the ground plane shall be folded back and forth in the center forming a bundle 30 to 40 cm long.
- I/O cables that are not connected to a peripheral shall be bundled in the center. The end of the cable may be terminated, if required, using the correct terminating impedance. The overall length shall not exceed 1 m.
- LISN at least 80 cm from nearest part of EUT chassis.
- For the actual test configuration, please refer to the related Item –EUT Test Photos.

3.1.3 DEVIATION FROM TEST STANDARD

No deviation

3.1.4 TEST SETUP

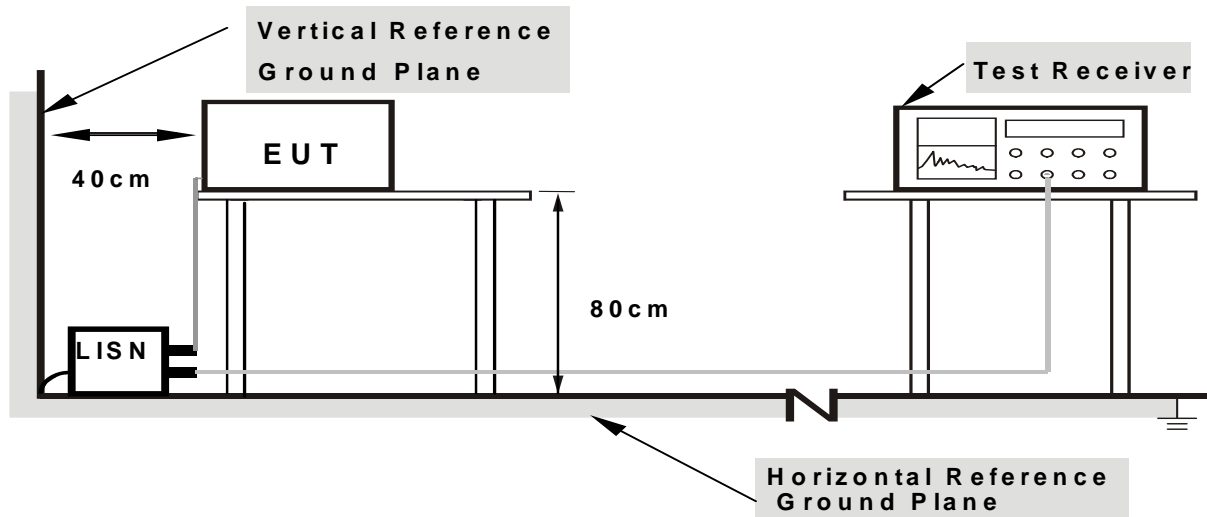

Note: 1. Support units were connected to second LISN.

2. Both of LISNs (AMN) are 80 cm from EUT and at least 80 cm from other units and other metal planes

3.1.5 EUT OPERATING CONDITIONS

The EUT was configured for testing in a typical fashion (as a customer would normally use it). The EUT has been programmed to continuously transmit during test. This operating condition was tested and used to collect the included data.

3.1.6 TEST RESULTS

EUT :	IEEE 802.11b/g/n Long Range AP-Router	Model Name. :	AIP-W525H
Temperature :	26 °C	Relative Humidity :	54%
Pressure :	1010hPa	Test Date :	2011-12-1
Test Mode :	Normal Link	Phase :	L
Test Voltage :	DC 12V		

Freq. (MHz)	Reading (dBuV)	Factor (dBuV)	Measurement (dBuV)	Limit (dBuV)	Over (dB)	Detector
0.17	36.32	10.45	46.77	64.96	-18.19	QP
0.17	33.71	10.45	44.16	54.96	-10.8	AVG
6.226	34.06	10.66	44.72	60	-15.28	QP
6.226	27.4	10.66	38.06	50	-11.94	AVG
17.814	40.68	10.72	51.4	60	-8.6	QP
17.814	29.65	10.72	40.37	50	-9.63	AVG

Remark:

1. All readings are Quasi-Peak and Average values.
2. Factor = Insertion Loss + Cable Loss.

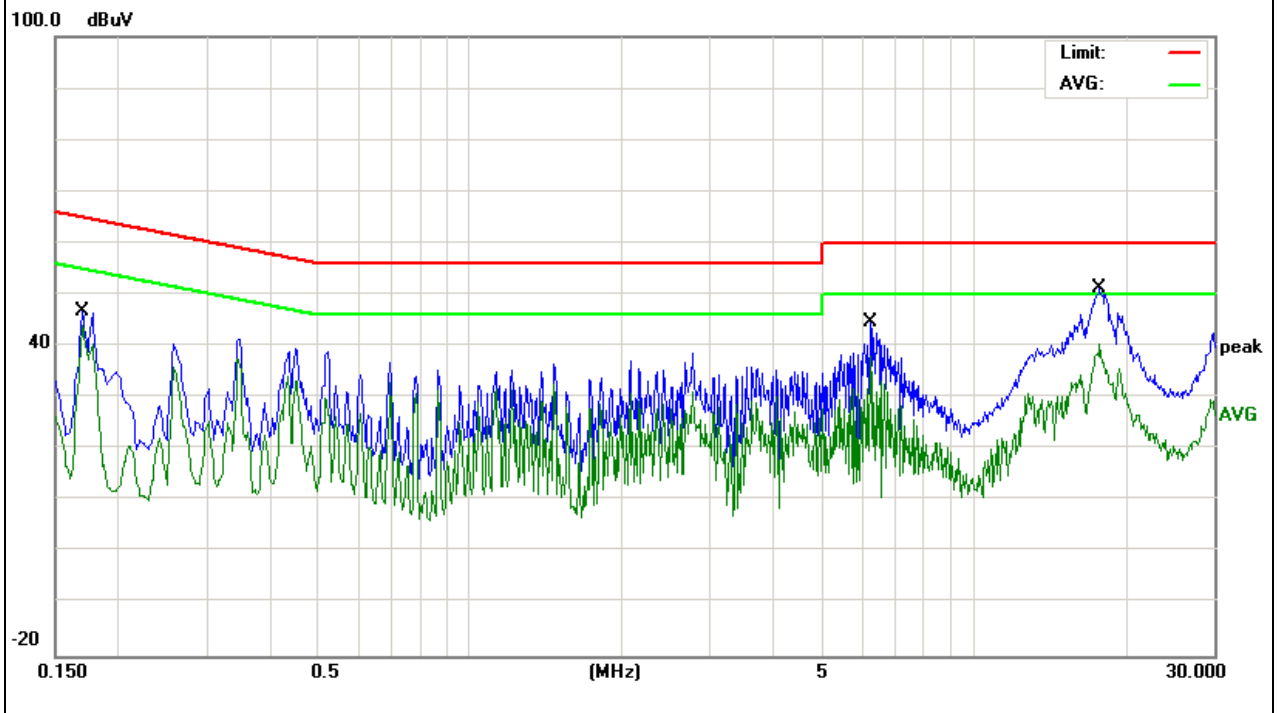

EUT :	IEEE 802.11b/g/n Long Range AP-Router	Model Name. :	AIP-W525H
Temperature :	26 °C	Relative Humidity :	54%
Pressure :	1010hPa	Test Date :	2011-12-1
Test Mode :	Normal Link	Phase :	N
Test Voltage :	DC 12V		

Freq. (MHz)	Reading (dBuV)	Factor (dBuV)	Measurement (dBuV)	Limit (dBuV)	Over (dB)	Detector
0.1737	40.02	10.36	50.38	64.78	-14.4	QP
0.1737	38.19	10.36	48.55	54.78	-6.23	AVG
6.2259	35.52	10.68	46.2	60	-13.8	QP
6.3098	27.46	10.67	38.13	50	-11.87	AVG
13.9177	32.37	10.72	43.09	50	-6.91	AVG
17.6377	42.34	10.75	53.09	60	-6.91	QP

Remark:

1. All readings are Quasi-Peak and Average values.
2. Factor = Insertion Loss + Cable Loss.

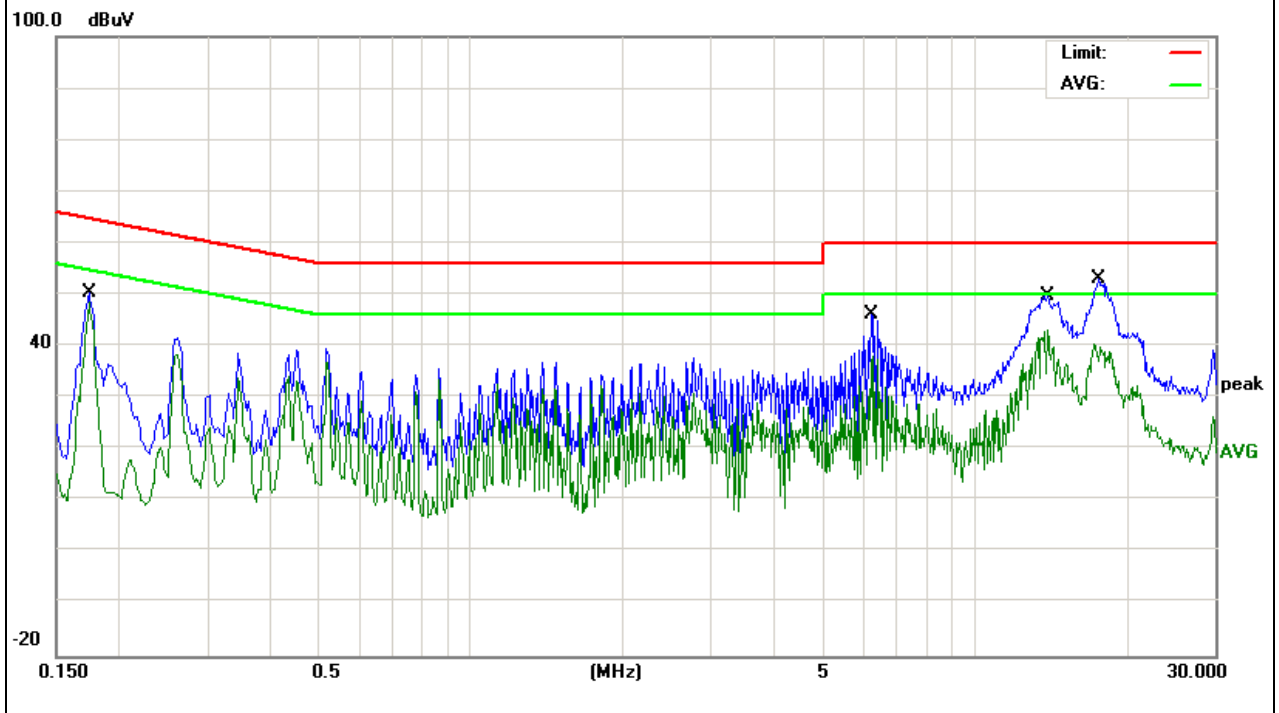

3.2 RADIATED EMISSION MEASUREMENT

3.2.1 RADIATED EMISSION LIMITS (Frequency Range 9kHz-1000MHz)

20dBc in any 100 kHz bandwidth outside the operating frequency band. In case the emission fall within the restricted band specified on 15.205(a), then the 15.209(a) limit in the table below has to be followed.

Frequencies (MHz)	Field Strength (microrvolts/meter)	Measurement Distance (meters)
0.009~0.490	2400/F(KHz)	300
0.490~1.705	24000/F(KHz)	30
1.705~30.0	30	30
30~88	100	3
88~216	150	3
216~960	200	3
Above 960	500	3

LIMITS OF RADIATED EMISSION MEASUREMENT (Above 1000MHz)

FREQUENCY (MHz)	Class A (dBuV/m) (at 3M)		Class B (dBuV/m) (at 3M)	
	PEAK	AVERAGE	PEAK	AVERAGE
Above 1000	80	60	74	54

Notes:

- (1) The limit for radiated test was performed according to FCC PART 15C.
- (2) The tighter limit applies at the band edges.
- (3) Emission level (dBuV/m)=20log Emission level (uV/m).

Spectrum Parameter	Setting
Attenuation	Auto
Start Frequency	1000 MHz
Stop Frequency	10th carrier harmonic
RB / VB (emission in restricted band)	1 MHz / 1 MHz for Peak, 1 MHz / 10Hz for Average

Receiver Parameter	Setting
Attenuation	Auto
Start ~ Stop Frequency	9kHz~150kHz / RB 200Hz for QP
Start ~ Stop Frequency	150kHz~30MHz / RB 9kHz for QP
Start ~ Stop Frequency	30MHz~1000MHz / RB 120kHz for QP

3.2.2 TEST PROCEDURE

- a. The measuring distance of at 3 m shall be used for measurements at frequency up to 1GHz. For frequencies above 1GHz, any suitable measuring distance may be used.
- b. The EUT was placed on the top of a rotating table 0.8 meters above the ground at a 3 meter open area test site. The table was rotated 360 degrees to determine the position of the highest radiation.
- c. The height of the equipment or of the substitution antenna shall be 0.8 m; the height of the test antenna shall vary between 1 m to 4 m. Both horizontal and vertical polarizations of the antenna are set to make the measurement.
- d. The initial step in collecting conducted emission data is a spectrum analyzer peak detector mode pre-scanning the measurement frequency range. Significant peaks are then marked and then Quasi Peak detector mode re-measured.
- e. If the Peak Mode measured value compliance with and lower than Quasi Peak Mode Limit, the EUT shall be deemed to meet QP Limits and then no additional QP Mode measurement performed.
- f. For the actual test configuration, please refer to the related Item –EUT Test Photos.

Note:

Both horizontal and vertical antenna polarities were tested and performed pretest to three orthogonal axis. The worst case emissions were reported

3.2.3 DEVIATION FROM TEST STANDARD

No deviation

3.2.4 TEST SETUP

(A) Radiated Emission Test-Up Frequency Below 30MHz

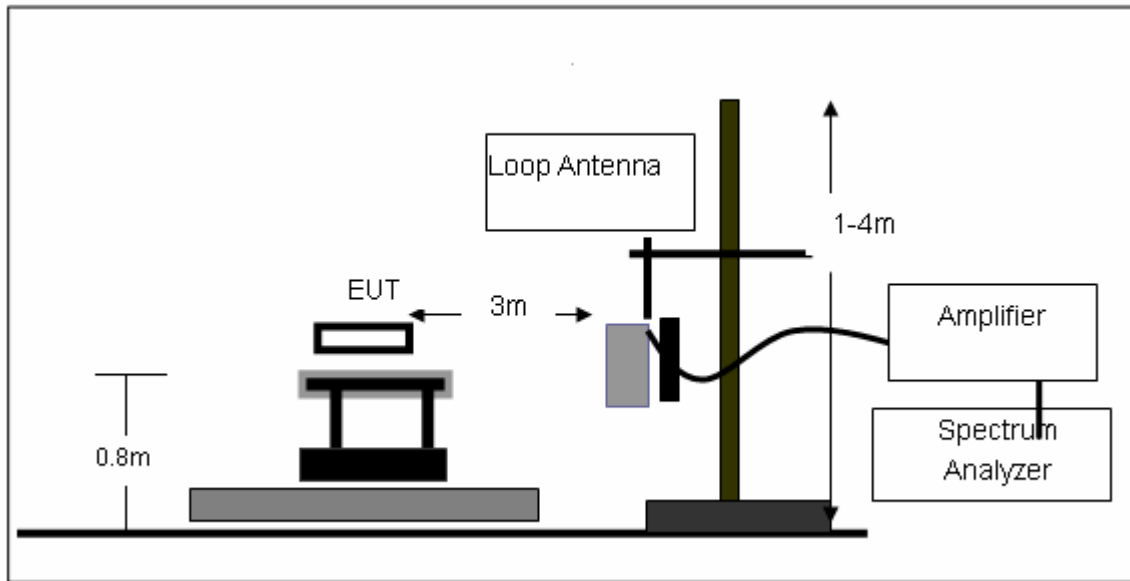

(B) Radiated Emission Test-Up Frequency 30MHz~1GHz

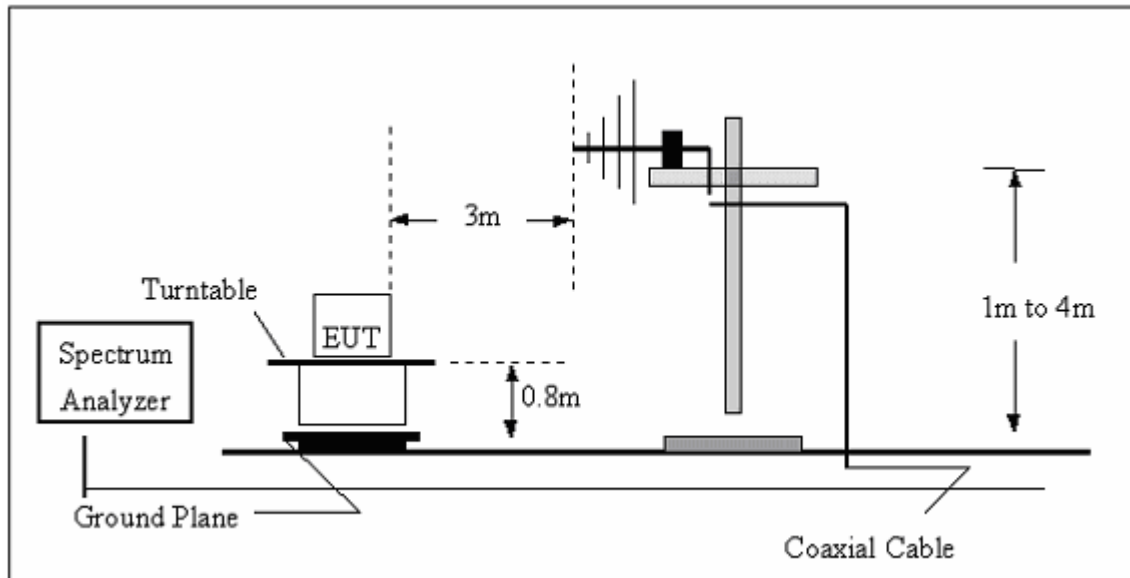

(C) Radiated Emission Test-Up Frequency Above 1GHz

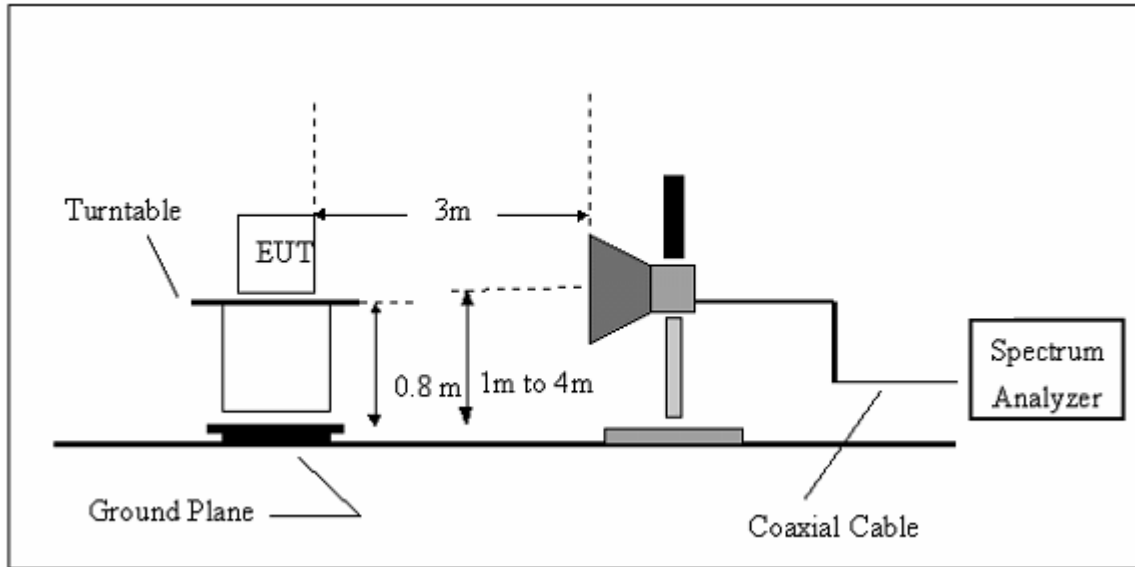

3.2.5 EUT OPERATING CONDITIONS

The EUT tested system was configured as the statements of 2.4 Unless otherwise a special operating condition is specified in the follows during the testing.

3.2.6 TEST RESULTS (BETWEEN 9KHZ – 30 MHZ)

EUT :	IEEE 802.11b/g/n Long Range AP-Router	Model Name. :	AIP-W525H
Temperature :	20 °C	Relative Humidity :	48%
Pressure :	1010 hPa	Test Voltage :	DC 12V
Test Mode :	TX	Polarization :	--

Freq. (MHz)	Reading (dBuV/m)	Limit (dBuV/m)	Margin (dB)	State P/F
--	--	--	--	PASS
--	--	--	--	PASS

NOTE:

The amplitude of spurious emissions which are attenuated by more than 20dB below the permissible value has no need to be reported.

Distance extrapolation factor = $20 \log(\text{specific distance}/\text{test distance})$ (dB);

Limit line = specific limits(dBuv) + distance extrapolation factor.

3.2.7 TEST RESULTS (BETWEEN 30MHZ – 1GHZ)

EUT :	IEEE 802.11b/g/n Long Range AP-Router	Model Name :	AIP-W525H
Temperature :	20 °C	Relative Humidity :	48%
Pressure :	1010 hPa	Test Voltage :	DC 12V
Test Mode :	TX	Polarization :	Horizontal

Frequency (MHz)	Meter Reading (dBμV)	Factor (dB)	Emission Level (dBμV/m)	Limits (dBμV/m)	Margin (dB)	Detector Type
71.3298	26.21	6.19	32.4	40	-7.6	QP
102.7192	23.4	10.8	34.2	43.5	-9.3	QP
545.1825	10.13	23.47	33.6	46	-12.4	QP

Remark:

- Factor = Antenna Factor + Cable Loss – Pre-amplifier.

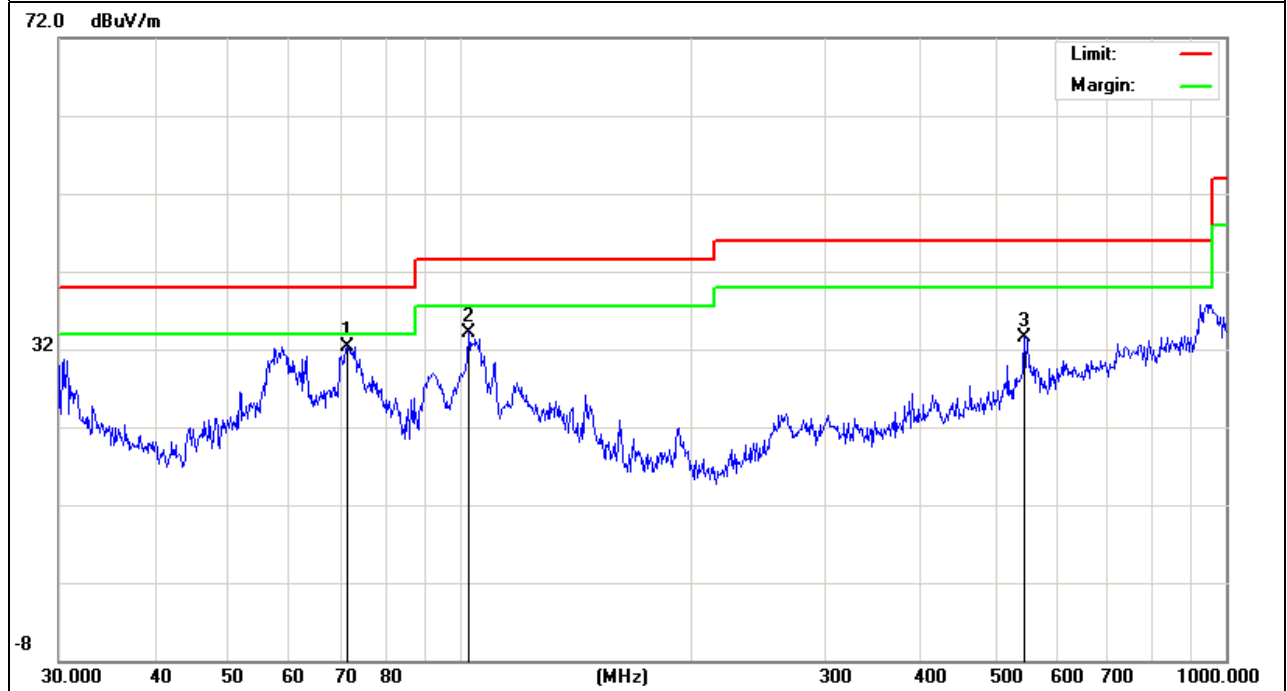

EUT :	IEEE 802.11b/g/n Long Range AP-Router	Model Name :	AIP-W525H
Temperature :	20 °C	Relative Humidity :	48%
Pressure :	1010 hPa	Test Voltage :	DC 12V
Test Mode :	TX	Polarization :	Vertical

Frequency (MHz)	Meter Reading (dBµV)	Factor (dB)	Emission Level (dBµV/m)	Limits (dBµV/m)	Margin (dB)	Detector Type
32.634	18.71	16.99	35.7	40	-4.3	QP
81.7831	26.95	8.05	35	40	-5	QP
541.3721	9.14	23.46	32.6	46	-13.4	QP

Remark:

1. Factor = Antenna Factor + Cable Loss – Pre-amplifier.

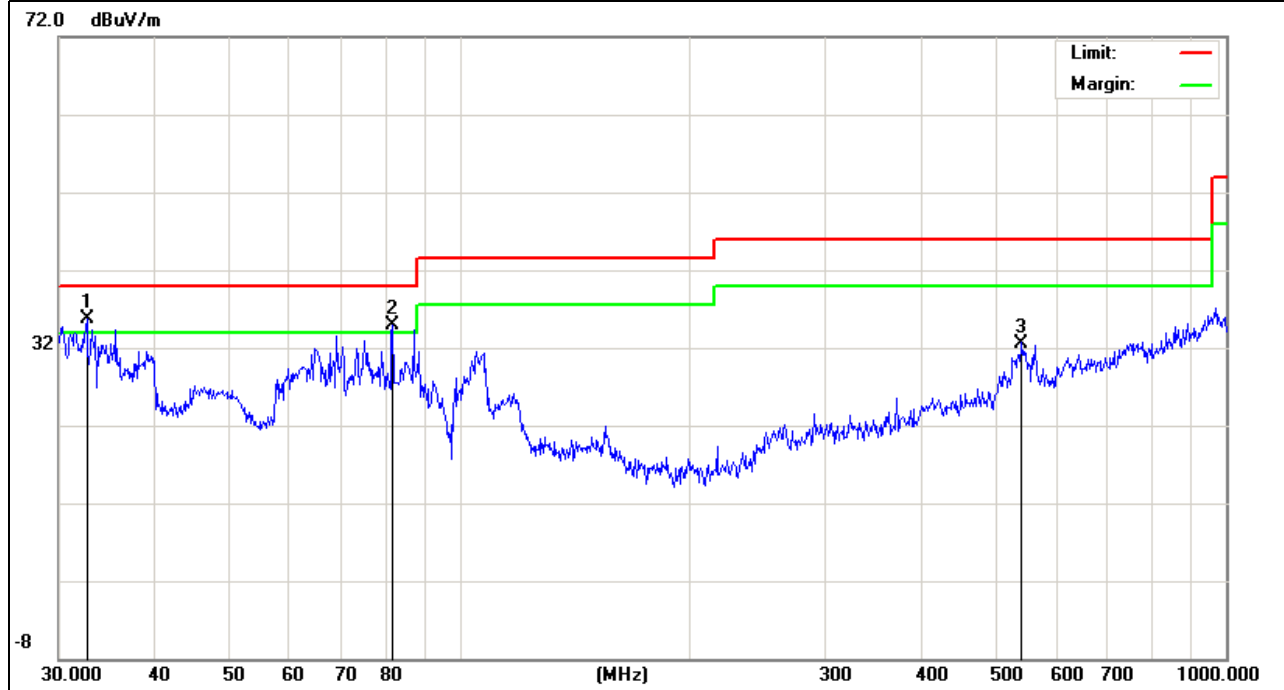

3.2.8 TEST RESULTS (ABOVE 1000 MHZ)

EUT :	IEEE 802.11b/g/n Long Range AP-Router	Model Name :	AIP-W525H
Temperature :	20 °C	Relative Humidity :	48%
Pressure :	1010 hPa	Test Voltage :	DC 12V
Test Mode :	CH1 (802.11b Mode)/2412	Polarization :	Horizontal

Frequency (MHz)	Meter Reading (dBµV)	Factor (dB)	Emission Level (dBµV/m)	Limits (dBµV/m)	Margin (dB)	Detector Type
1143.2	55.85	-4.69	51.16	74	-22.84	peak
1143.2	45.33	-4.69	40.64	54	-13.36	AVG
4810.62	46.52	10.41	56.93	74	-17.07	peak
4810.62	32.74	10.41	43.15	54	-10.85	AVG
7215.94	46.52	12.39	58.91	74	-15.09	peak
7215.94	30.48	12.39	42.87	54	-11.13	AVG
9623.14	36.88	16.06	52.94	74	-21.06	peak
9623.14	25.45	16.06	41.51	54	-12.49	AVG

Remark:

Factor = Antenna Factor + Cable Loss – Pre-amplifier.

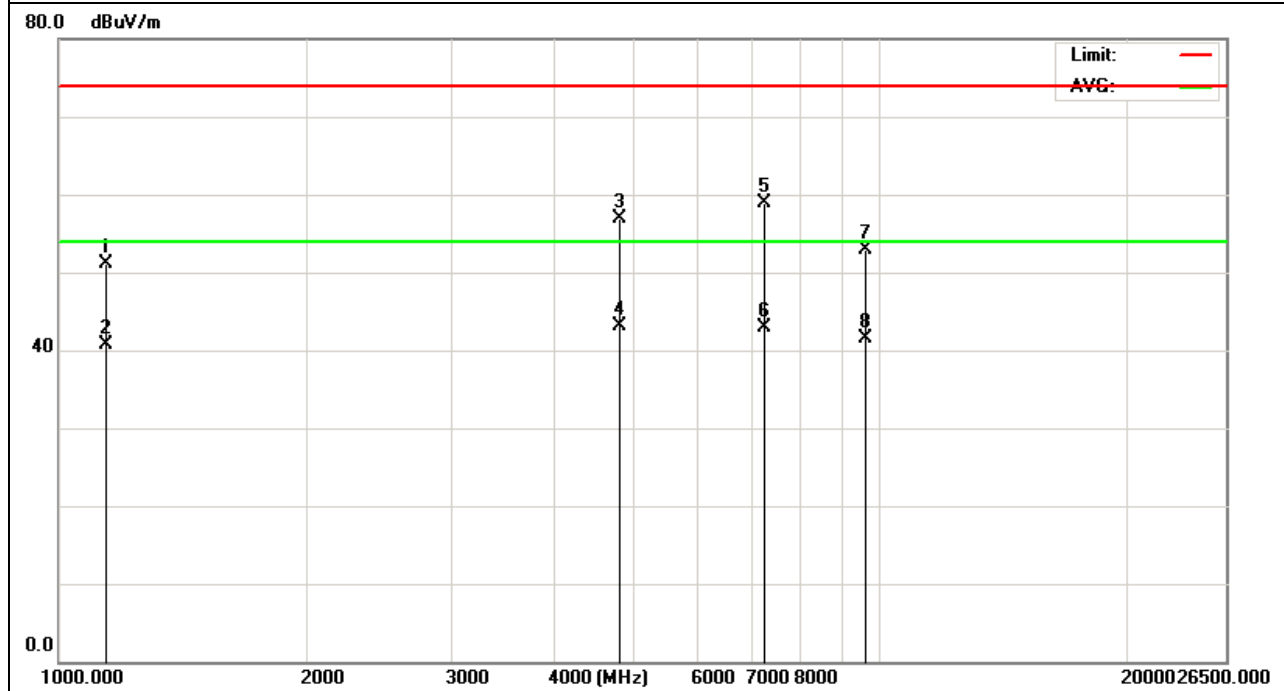

EUT :	IEEE 802.11b/g/n Long Range AP-Router	Model Name :	AIP-W525H
Temperature :	20 °C	Relative Humidity :	48%
Pressure :	1010 hPa	Test Voltage :	DC 12V
Test Mode :	CH1 (802.11b Mode)/2412	Polarization :	Vertical

Frequency (MHz)	Meter Reading (dBμV)	Factor (dB)	Emission Level (dBμV/m)	Limits (dBμV/m)	Margin (dB)	Detector Type
1143.2	55.1	-4.69	50.41	74	-23.59	peak
1143.2	44.03	-4.69	39.34	54	-14.66	AVG
4810.62	45.53	10.41	55.94	74	-18.06	peak
4810.62	32.23	10.41	42.64	54	-11.36	AVG
7215.94	46.52	12.39	58.91	74	-15.09	peak
7215.94	28.09	12.39	40.48	54	-13.52	AVG

Remark:
 Factor = Antenna Factor + Cable Loss – Pre-amplifier.

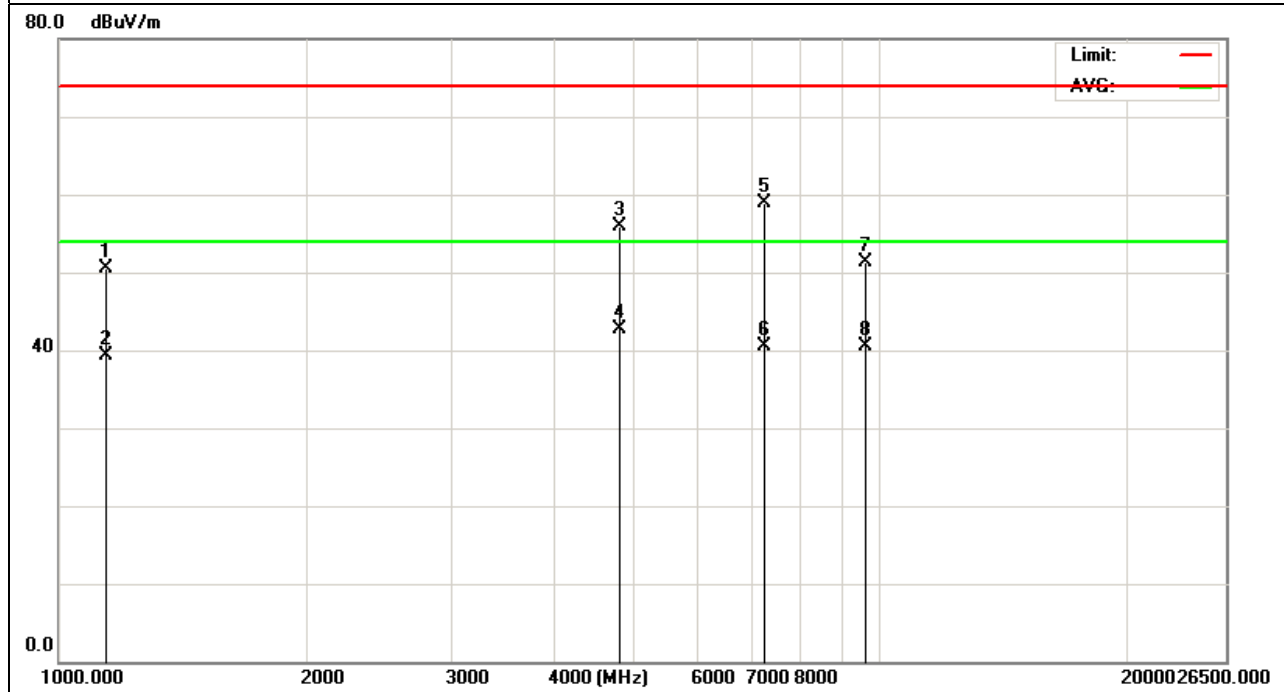

EUT :	IEEE 802.11b/g/n Long Range AP-Router	Model Name :	AIP-W525H
Temperature :	20 °C	Relative Humidity :	48%
Pressure :	1010 hPa	Test Voltage :	DC 12V
Test Mode :	CH6 (802.11b Mode)/2437	Polarization :	Horizontal

Frequency (MHz)	Meter Reading (dBµV)	Factor (dB)	Emission Level (dBµV/m)	Limits (dBµV/m)	Margin (dB)	Detector Type
1645.32	53.46	-3.05	50.41	74	-23.59	peak
1645.32	42.39	-3.05	39.34	54	-14.66	AVG
4882.16	45.58	10.36	55.94	74	-18.06	peak
4882.16	32.28	10.36	42.64	54	-11.36	AVG
7323.45	46.14	12.77	58.91	74	-15.09	peak
7323.45	27.71	12.77	40.48	54	-13.52	AVG

Remark:

- Factor = Antenna Factor + Cable Loss – Pre-amplifier.
- No emission detected above 18GHz

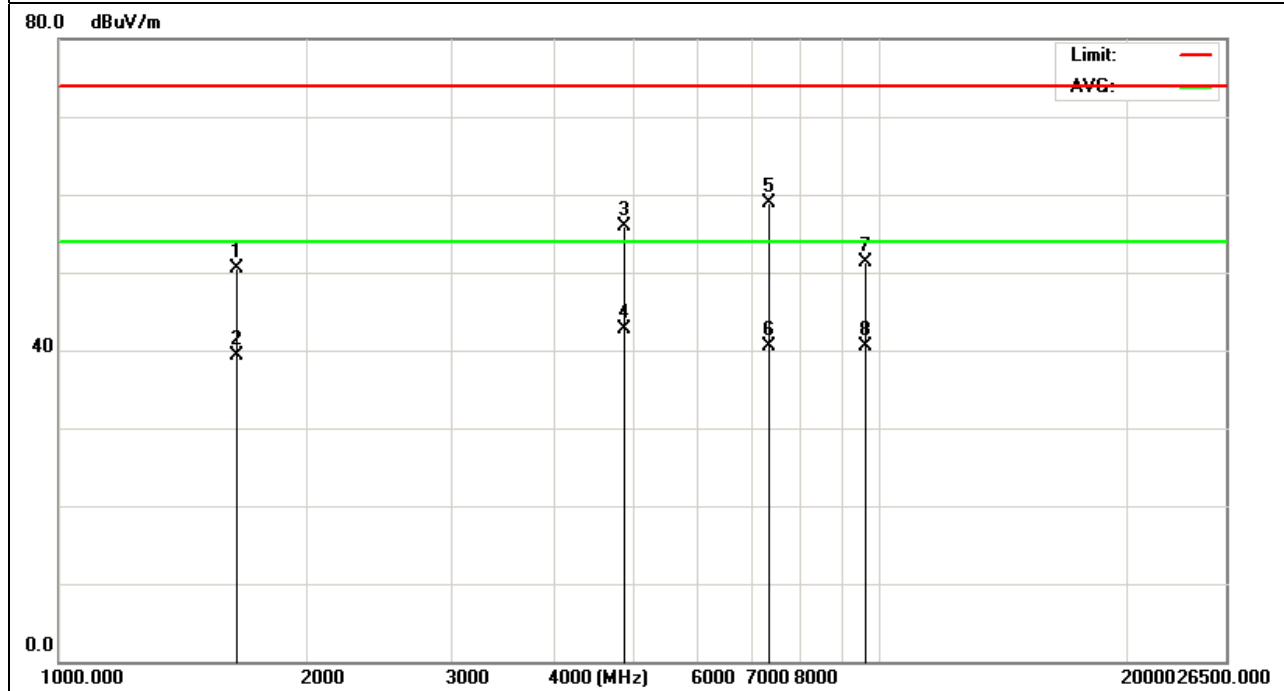

EUT :	IEEE 802.11b/g/n Long Range AP-Router	Model Name :	AIP-W525H
Temperature :	20 °C	Relative Humidity :	48%
Pressure :	1010 hPa	Test Voltage :	DC 12V
Test Mode :	CH6 (802.11b Mode)/2437	Polarization :	Vertical

Frequency (MHz)	Meter Reading (dBμV)	Factor (dB)	Emission Level (dBμV/m)	Limits (dBμV/m)	Margin (dB)	Detector Type
1645.32	57.61	-3.05	54.56	74	-19.44	peak
1645.32	44.83	-3.05	41.78	54	-12.22	AVG
4882.16	40.88	10.36	51.24	74	-22.76	peak
4882.16	30.61	10.36	40.97	54	-13.03	AVG
7323.45	42.97	12.77	55.74	74	-18.26	peak
7323.45	28.51	12.77	41.28	54	-12.72	AVG
9623.14	34.58	16.06	50.64	74	-23.36	peak
9623.14	23.81	16.06	39.87	54	-14.13	AVG

Remark:

- Factor = Antenna Factor + Cable Loss – Pre-amplifier.
- No emission detected above 18GHz

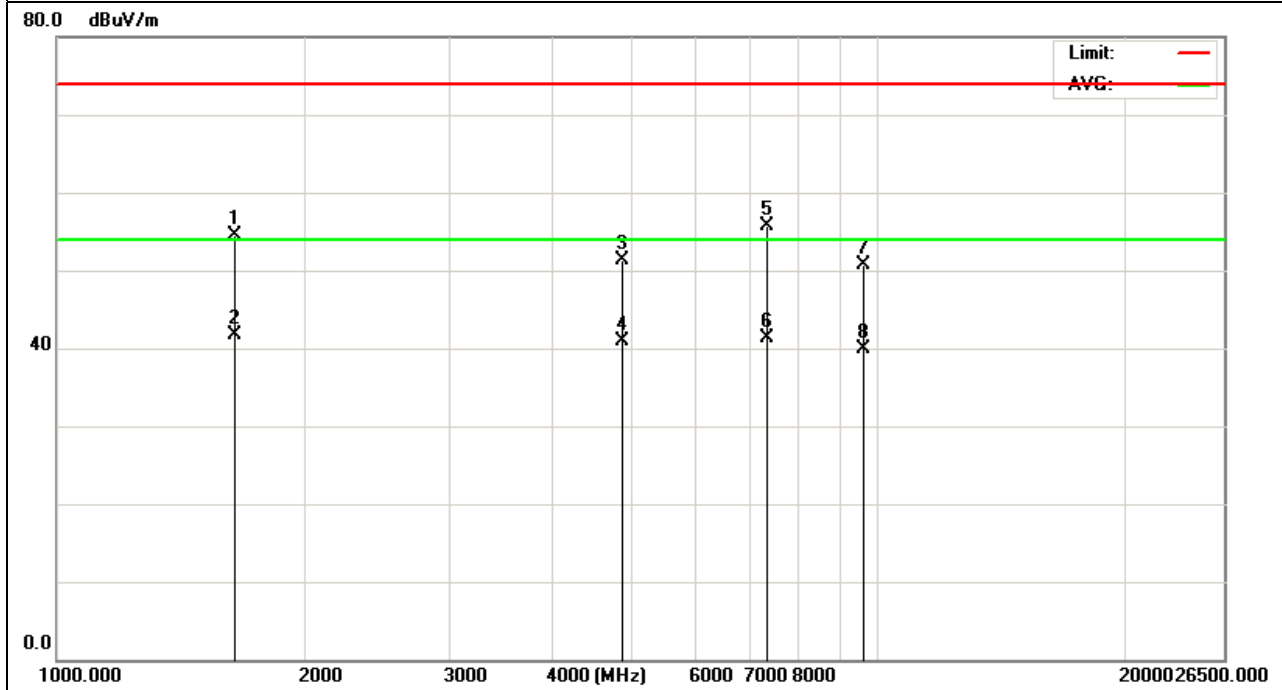

EUT :	IEEE 802.11b/g/n Long Range AP-Router	Model Name :	AIP-W525H
Temperature :	20 °C	Relative Humidity :	48%
Pressure :	1010 hPa	Test Voltage :	DC 12V
Test Mode :	CH11 (802.11b Mode)/2462	Polarization :	Horizontal

Frequency (MHz)	Meter Reading (dBμV)	Factor (dB)	Emission Level (dBμV/m)	Limits (dBμV/m)	Margin (dB)	Detector Type
1884.32	55.55	-1.89	53.66	74	-20.34	peak
1884.32	44.86	-1.89	42.97	54	-11.03	AVG
4954.81	44.48	10.49	54.97	74	-19.03	peak
4954.81	32.26	10.49	42.75	54	-11.25	AVG
7431.66	37.63	13.03	50.66	74	-23.34	peak
7431.66	28.88	13.03	41.91	54	-12.09	AVG
9911.54	32.08	16.2	48.28	74	-25.72	peak
9911.54	19.91	16.2	36.11	54	-17.89	AVG

Remark:

- 3. Factor = Antenna Factor + Cable Loss – Pre-amplifier.
- 4. No emission detected above 18GHz

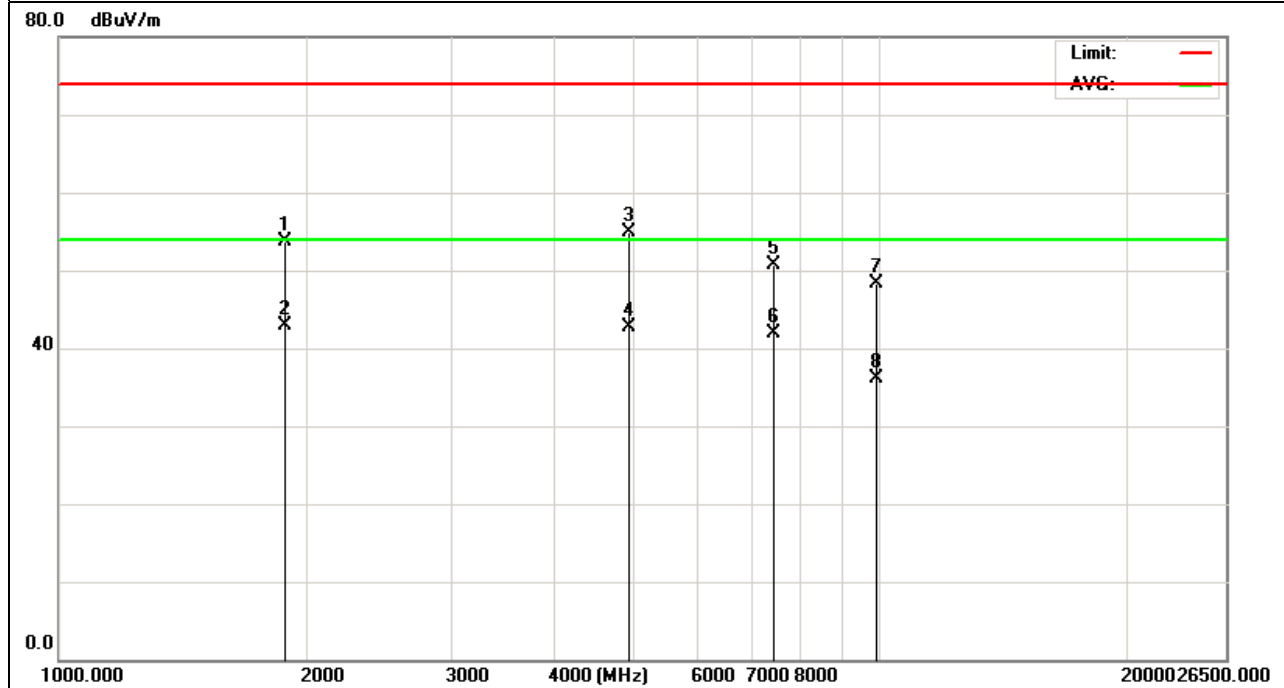

EUT :	IEEE 802.11b/g/n Long Range AP-Router	Model Name :	AIP-W525H
Temperature :	20 °C	Relative Humidity :	48%
Pressure :	1010 hPa	Test Voltage :	DC 12V
Test Mode :	CH11 (802.11b Mode)/2462	Polarization :	Vertical

Frequency (MHz)	Meter Reading (dBµV)	Factor (dB)	Emission Level (dBµV/m)	Limits (dBµV/m)	Margin (dB)	Detector Type
1884.32	55.17	-1.89	53.28	74	-20.72	peak
1884.32	44.5	-1.89	42.61	54	-11.39	AVG
4954.81	42.67	10.49	53.16	74	-20.84	peak
4954.81	30.92	10.49	41.41	54	-12.59	AVG
7431.66	37.99	13.03	51.02	74	-22.98	peak
7431.66	27.94	13.03	40.97	54	-13.03	AVG
9911.54	31.44	16.2	47.64	74	-26.36	peak
9911.54	19.14	16.2	35.34	54	-18.66	AVG

Remark:

Factor = Antenna Factor + Cable Loss – Pre-amplifier.

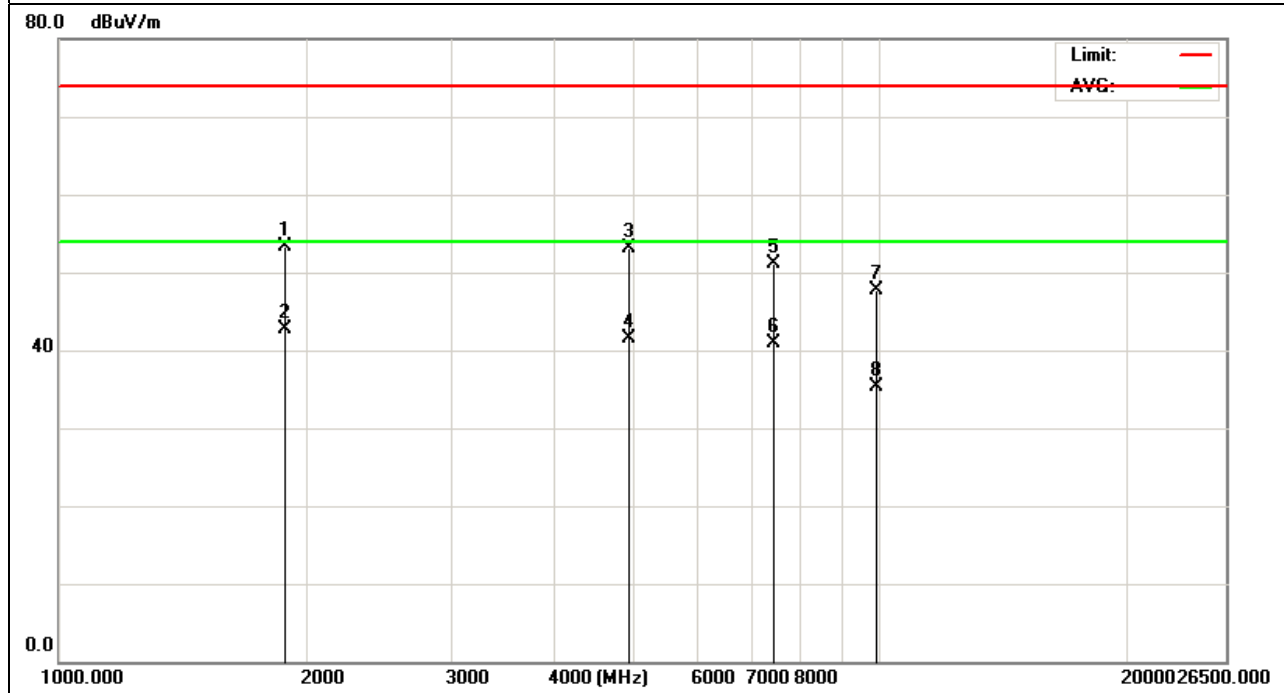

EUT :	IEEE 802.11b/g/n Long Range AP-Router	Model Name :	AIP-W525H
Temperature :	20 °C	Relative Humidity :	48%
Pressure :	1010 hPa	Test Voltage :	DC 12V
Test Mode :	CH1 (802.11g Mode)/2412	Polarization :	Horizontal

Frequency (MHz)	Meter Reading (dBμV)	Factor (dB)	Emission Level (dBμV/m)	Limits (dBμV/m)	Margin (dB)	Detector Type
1231.15	56.52	-3.88	52.64	74	-21.36	peak
1231.15	45.37	-3.88	41.49	54	-12.51	AVG
4810.62	45.13	10.41	55.54	74	-18.46	peak
4810.62	32.23	10.41	42.64	54	-11.36	AVG
7215.94	42.59	12.39	54.98	74	-19.02	peak
7215.94	28.28	12.39	40.67	54	-13.33	AVG
9623.14	34.05	16.06	50.11	74	-23.89	peak
9623.14	23.29	16.06	39.35	54	-14.65	AVG

Remark:

Factor = Antenna Factor + Cable Loss – Pre-amplifier.

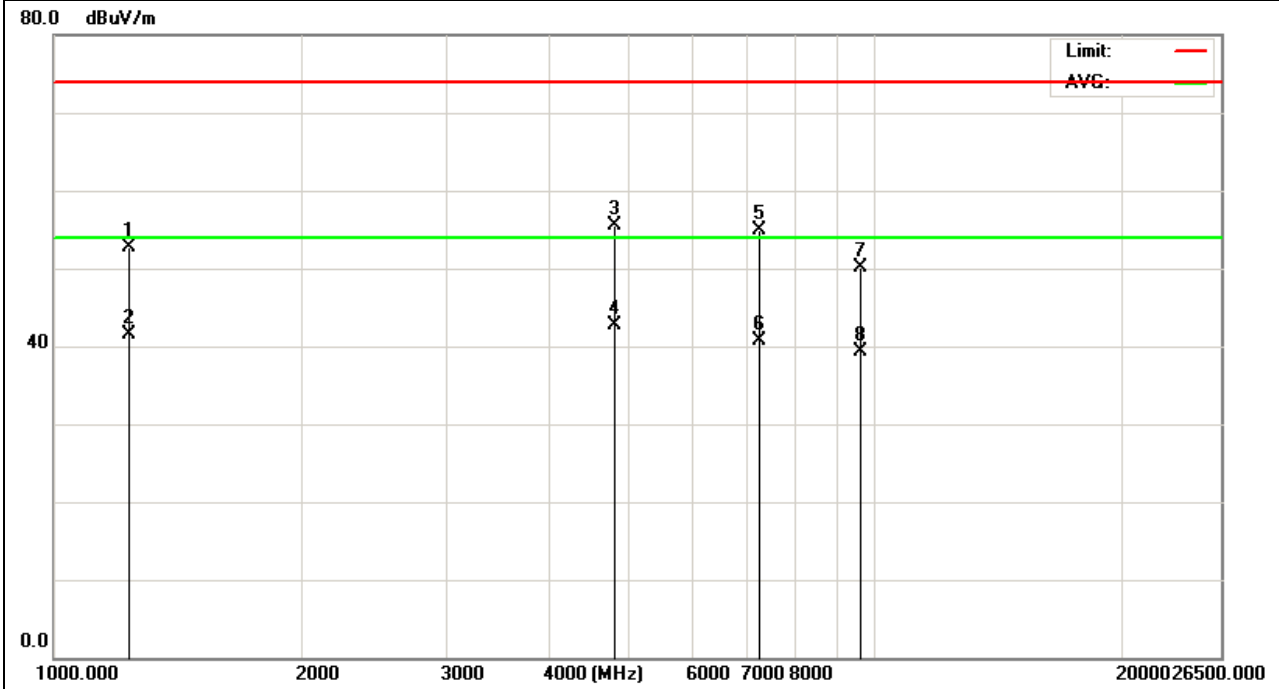

EUT :	IEEE 802.11b/g/n Long Range AP-Router	Model Name :	AIP-W525H
Temperature :	20 °C	Relative Humidity :	48%
Pressure :	1010 hPa	Test Voltage :	DC 12V
Test Mode :	CH1 (802.11g Mode)/2412	Polarization :	Vertical

Frequency (MHz)	Meter Reading (dBμV)	Factor (dB)	Emission Level (dBμV/m)	Limits (dBμV/m)	Margin (dB)	Detector Type
1231.64	54.23	-3.88	50.35	74	-23.65	peak
1231.64	44.54	-3.88	40.66	54	-13.34	AVG
4810.62	43.12	10.41	53.53	74	-20.47	peak
4810.62	31.7	10.41	42.11	54	-11.89	AVG
7215.94	41.27	12.39	53.66	74	-20.34	peak
7215.94	28.29	12.39	40.68	54	-13.32	AVG
9623.14	34.72	16.06	50.78	74	-23.22	peak
9623.14	24.17	16.06	40.23	54	-13.77	AVG

Remark:

Factor = Antenna Factor + Cable Loss – Pre-amplifier.

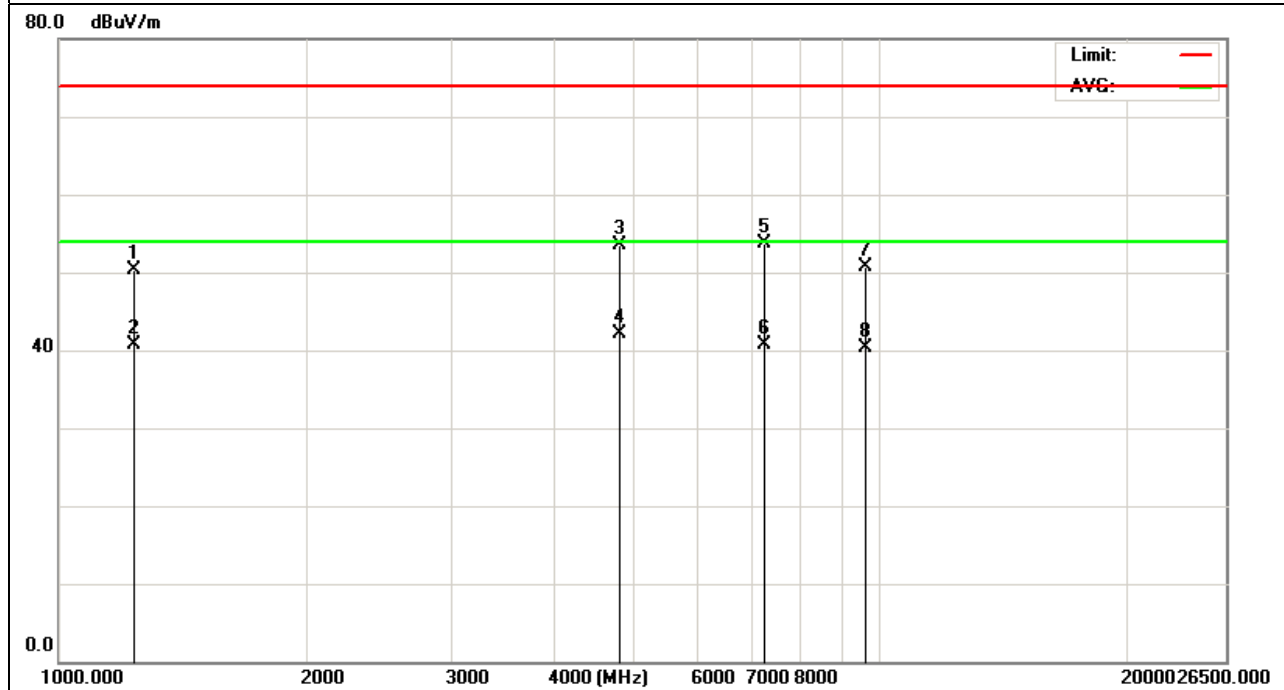

EUT :	IEEE 802.11b/g/n Long Range AP-Router	Model Name :	AIP-W525H
Temperature :	20 °C	Relative Humidity :	48%
Pressure :	1010 hPa	Test Voltage :	DC 12V
Test Mode :	CH6 (802.11g Mode)/2437	Polarization :	Horizontal

Frequency (MHz)	Meter Reading (dBμV)	Factor (dB)	Emission Level (dBμV/m)	Limits (dBμV/m)	Margin (dB)	Detector Type
1556.24	55.32	-3.68	51.64	74	-22.36	peak
1556.24	44.01	-3.68	40.33	54	-13.67	AVG
4882.16	46.2	10.36	56.56	74	-17.44	peak
4882.16	33.45	10.36	43.81	54	-10.19	AVG
7323.45	42.4	12.77	55.17	74	-18.83	peak
7323.45	28.2	12.77	40.97	54	-13.03	AVG

Remark:
Factor = Antenna Factor + Cable Loss – Pre-amplifier.

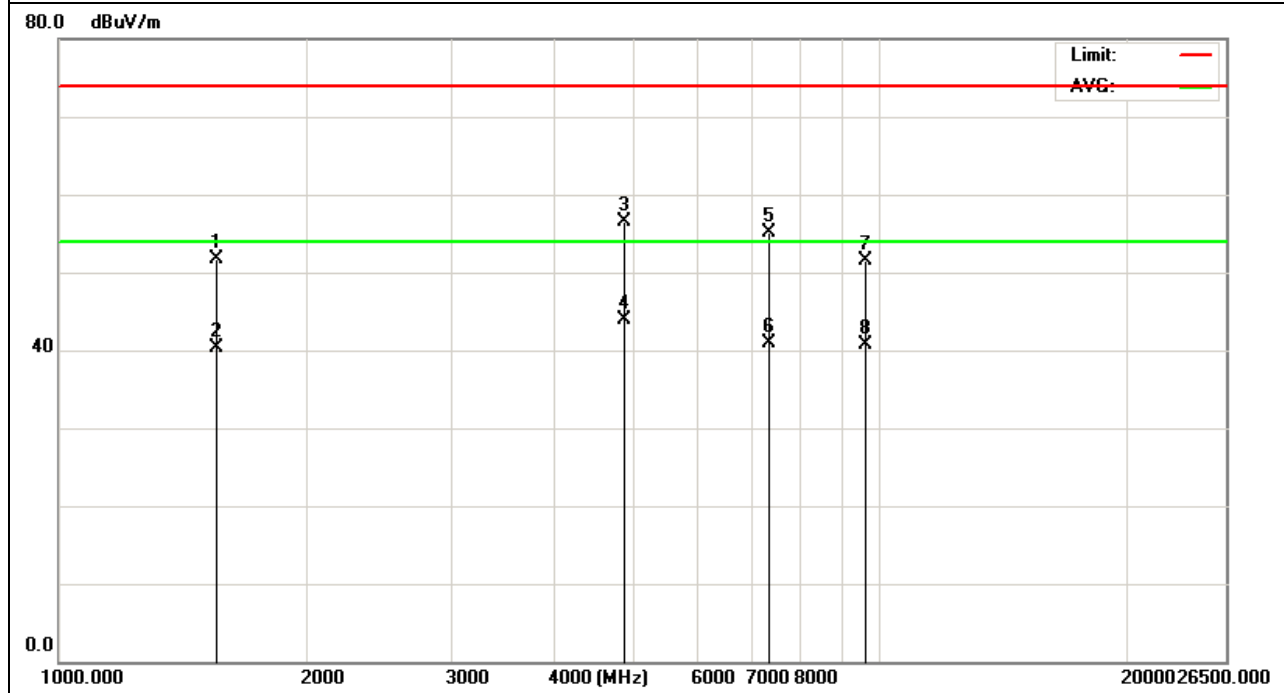

EUT :	IEEE 802.11b/g/n Long Range AP-Router	Model Name :	AIP-W525H
Temperature :	20 °C	Relative Humidity :	48%
Pressure :	1010 hPa	Test Voltage :	DC 12V
Test Mode :	CH6 (802.11g Mode)/2437	Polarization :	Vertical

Frequency (MHz)	Meter Reading (dBµV)	Factor (dB)	Emission Level (dBµV/m)	Limits (dBµV/m)	Margin (dB)	Detector Type
1556.24	56.87	-3.68	53.19	74	-20.81	peak
1556.24	46.02	-3.68	42.34	54	-11.66	AVG
4882.16	42.61	10.36	52.97	74	-21.03	peak
4882.16	31.48	10.36	41.84	54	-12.16	AVG
7323.45	41.42	12.77	54.19	74	-19.81	peak
7323.45	30.07	12.77	42.84	54	-11.16	AVG

Remark:
Factor = Antenna Factor + Cable Loss – Pre-amplifier.

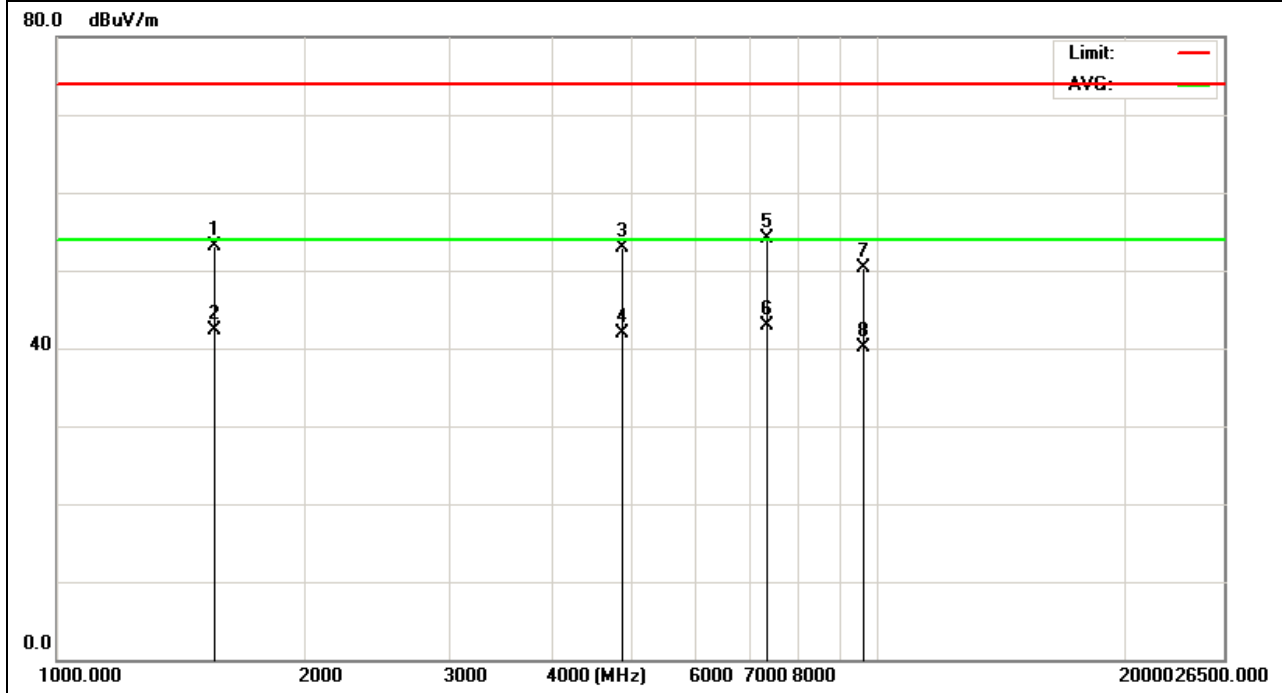

EUT :	IEEE 802.11b/g/n Long Range AP-Router	Model Name :	AIP-W525H
Temperature :	20 °C	Relative Humidity :	48%
Pressure :	1010 hPa	Test Voltage :	DC 12V
Test Mode :	CH11 (802.11g Mode)/2462	Polarization :	Horizontal

Frequency (MHz)	Meter Reading (dBμV)	Factor (dB)	Emission Level (dBμV/m)	Limits (dBμV/m)	Margin (dB)	Detector Type
1884.32	52.55	-1.89	50.66	74	-23.34	peak
1884.32	42.68	-1.89	40.79	54	-13.21	AVG
4954.81	43.82	10.49	54.31	74	-19.69	peak
4954.81	32.3	10.49	42.79	54	-11.21	AVG
7431.66	37.96	13.03	50.99	74	-23.01	peak
7431.66	26.33	13.03	39.36	54	-14.64	AVG
9911.54	32.49	16.2	48.69	74	-25.31	peak
9911.54	21.44	16.2	37.64	54	-16.36	AVG

Remark:

Factor = Antenna Factor + Cable Loss – Pre-amplifier.

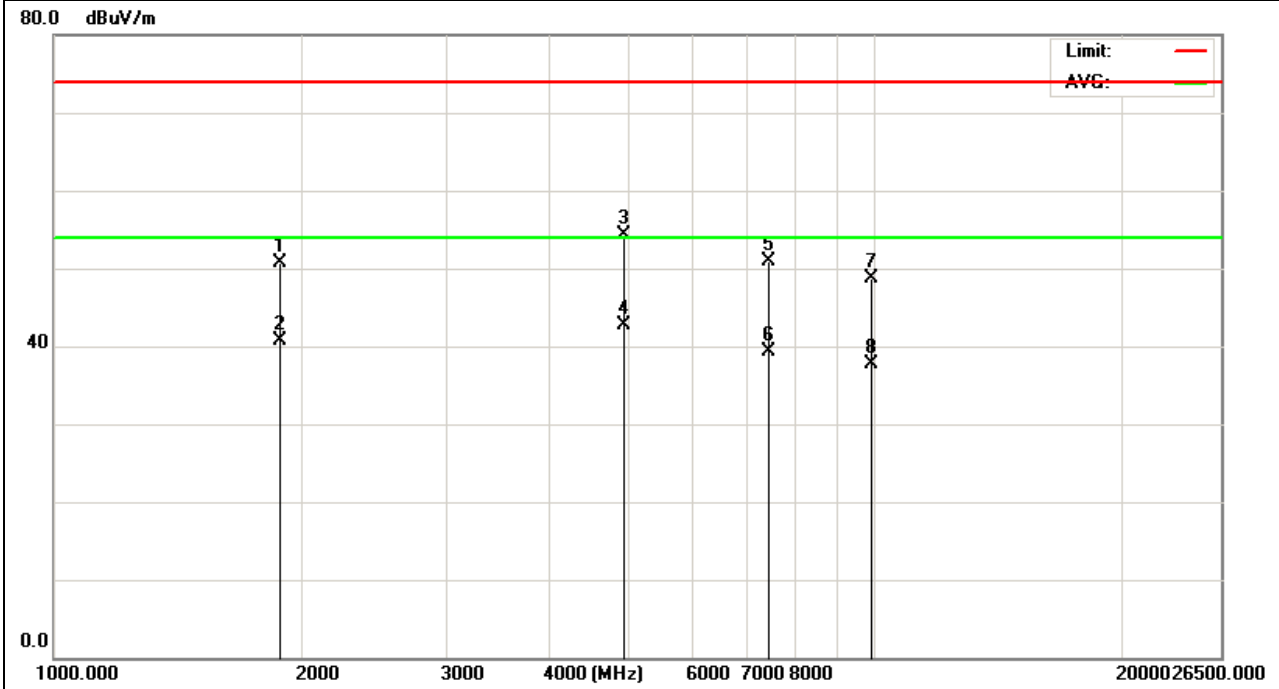

EUT :	IEEE 802.11b/g/n Long Range AP-Router	Model Name :	AIP-W525H
Temperature :	20 °C	Relative Humidity :	48%
Pressure :	1010 hPa	Test Voltage :	DC 12V
Test Mode :	CH11(802.11g Mode)/2462	Polarization :	Vertical

Frequency (MHz)	Meter Reading (dBµV)	Factor (dB)	Emission Level (dBµV/m)	Limits (dBµV/m)	Margin (dB)	Detector Type
1884.32	53.15	-1.89	51.26	74	-22.74	peak
1884.32	42.77	-1.89	40.88	54	-13.12	AVG
4954.81	42.8	10.49	53.29	74	-20.71	peak
4954.81	31.1	10.49	41.59	54	-12.41	AVG
7431.66	38.63	13.03	51.66	74	-22.34	peak
7431.66	27.15	13.03	40.18	54	-13.82	AVG
9911.54	33.27	16.2	49.47	74	-24.53	peak
9911.54	21.09	16.2	37.29	54	-16.71	AVG

Remark:

Factor = Antenna Factor + Cable Loss – Pre-amplifier.

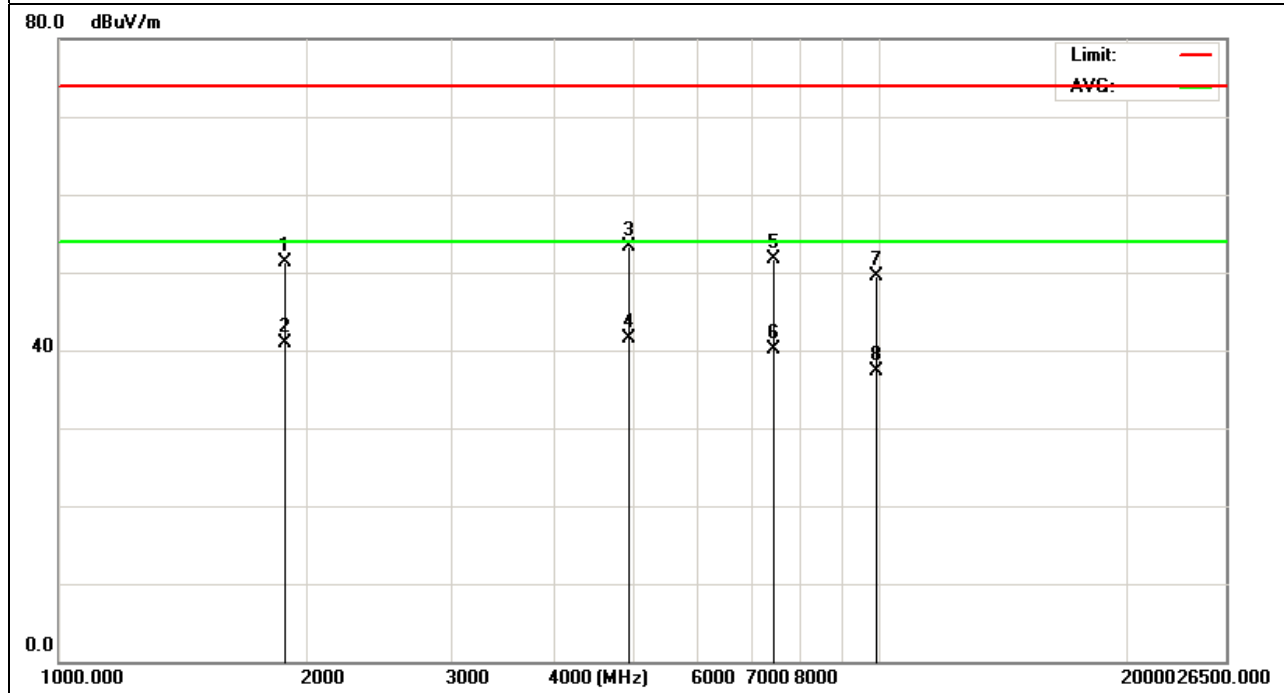

EUT :	IEEE 802.11b/g/n Long Range AP-Router	Model Name :	AIP-W525H
Temperature :	20 °C	Relative Humidity :	48%
Pressure :	1010 hPa	Test Voltage :	DC 12V
Test Mode :	CH1(802.11n Mode)/20MHz (A+B)Antenna	Polarization :	Horizontal

Frequency (MHz)	Meter Reading (dBµV)	Factor (dB)	Emission Level (dBµV/m)	Limits (dBµV/m)	Margin (dB)	Detector Type
4824.14	42.85	10.44	53.29	74	-20.71	peak
4824.14	31.15	10.44	41.59	54	-12.41	AVG
7239.35	39.27	12.39	51.66	74	-22.34	peak
7239.35	27.79	12.39	40.18	54	-13.82	AVG
9648.23	33.8	15.67	49.47	74	-24.53	peak
9648.23	21.62	15.67	37.29	54	-16.71	AVG

Remark:
Factor = Antenna Factor + Cable Loss – Pre-amplifier.

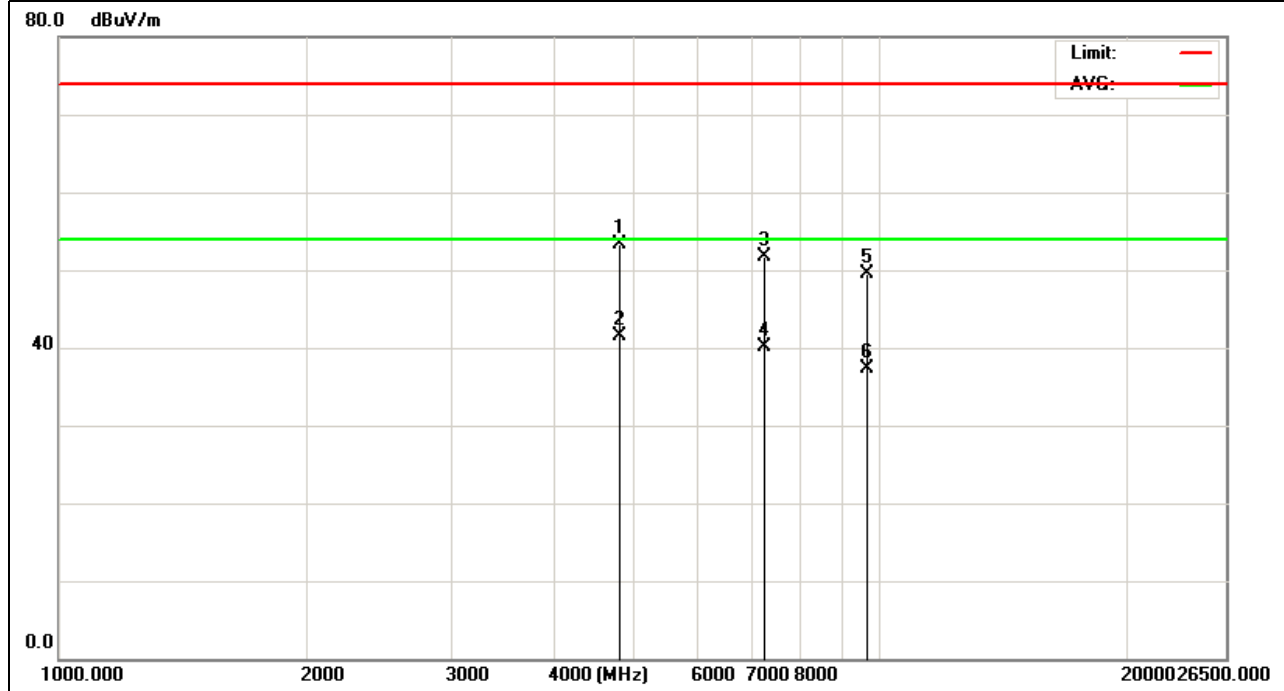

EUT :	IEEE 802.11b/g/n Long Range AP-Router	Model Name :	AIP-W525H
Temperature :	20 °C	Relative Humidity :	48%
Pressure :	1010 hPa	Test Voltage :	DC 12V
Test Mode :	CH1(802.11n Mode)/20MHz (A+B)Antenna	Polarization :	Vertical

Frequency (MHz)	Meter Reading (dBµV)	Factor (dB)	Emission Level (dBµV/m)	Limits (dBµV/m)	Margin (dB)	Detector Type
4824.14	43.68	10.44	54.12	74	-19.88	peak
4824.14	31.91	10.44	42.35	54	-11.65	AVG
7239.35	38.35	12.39	50.74	74	-23.26	peak
7239.35	27.94	12.39	40.33	54	-13.67	AVG
9648.23	31.58	15.67	47.25	74	-26.75	peak
9648.23	18.11	15.67	33.78	54	-20.22	AVG

Remark:
Factor = Antenna Factor + Cable Loss – Pre-amplifier.

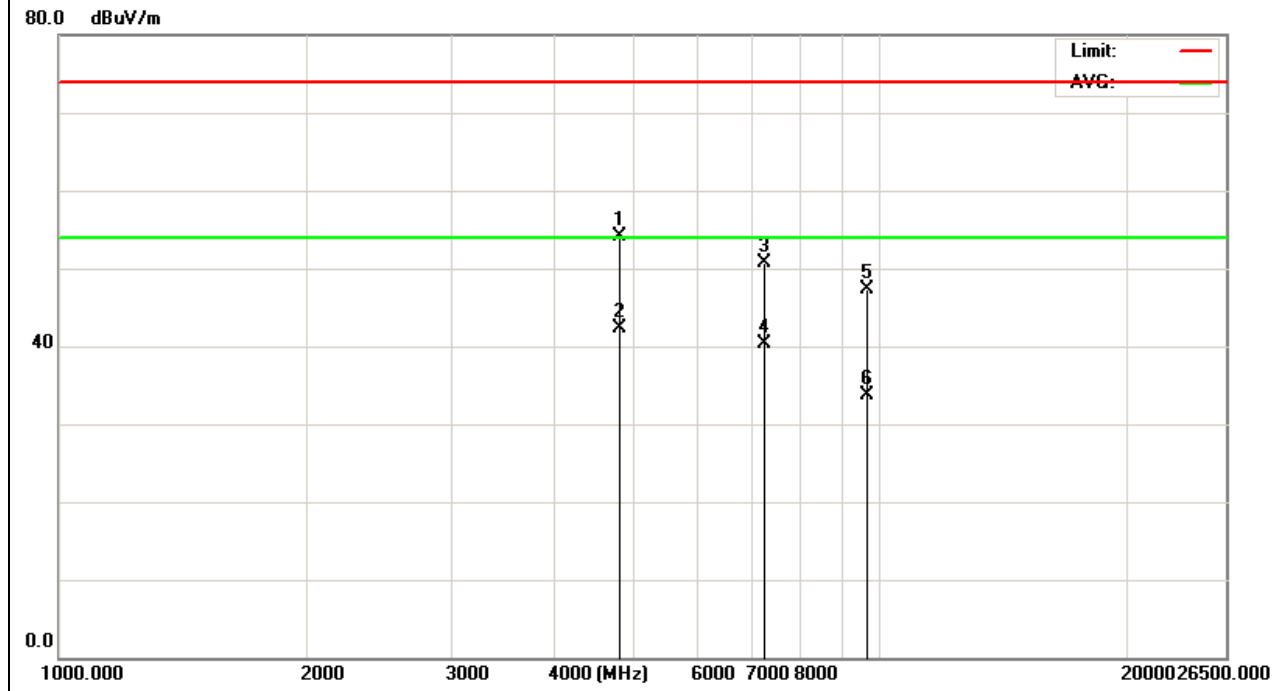

EUT :	IEEE 802.11b/g/n Long Range AP-Router	Model Name :	AIP-W525H
Temperature :	20 °C	Relative Humidity :	48%
Pressure :	1010 hPa	Test Voltage :	DC 12V
Test Mode :	CH6(802.11n Mode)/20MHz (A+B)Antenna	Polarization :	Horizontal

Frequency (MHz)	Meter Reading (dBμV)	Factor (dB)	Emission Level (dBμV/m)	Limits (dBμV/m)	Margin (dB)	Detector Type
4874.33	45.24	10.4	55.64	74	-18.36	peak
4874.33	33.27	10.4	43.67	54	-10.33	AVG
7311.84	38.79	12.75	51.54	74	-22.46	peak
7311.84	28.73	12.75	41.48	54	-12.52	AVG
9648.23	29.66	15.67	45.33	74	-28.67	peak
9648.23	16.45	15.67	32.12	54	-21.88	AVG

Remark:
 Factor = Antenna Factor + Cable Loss – Pre-amplifier.

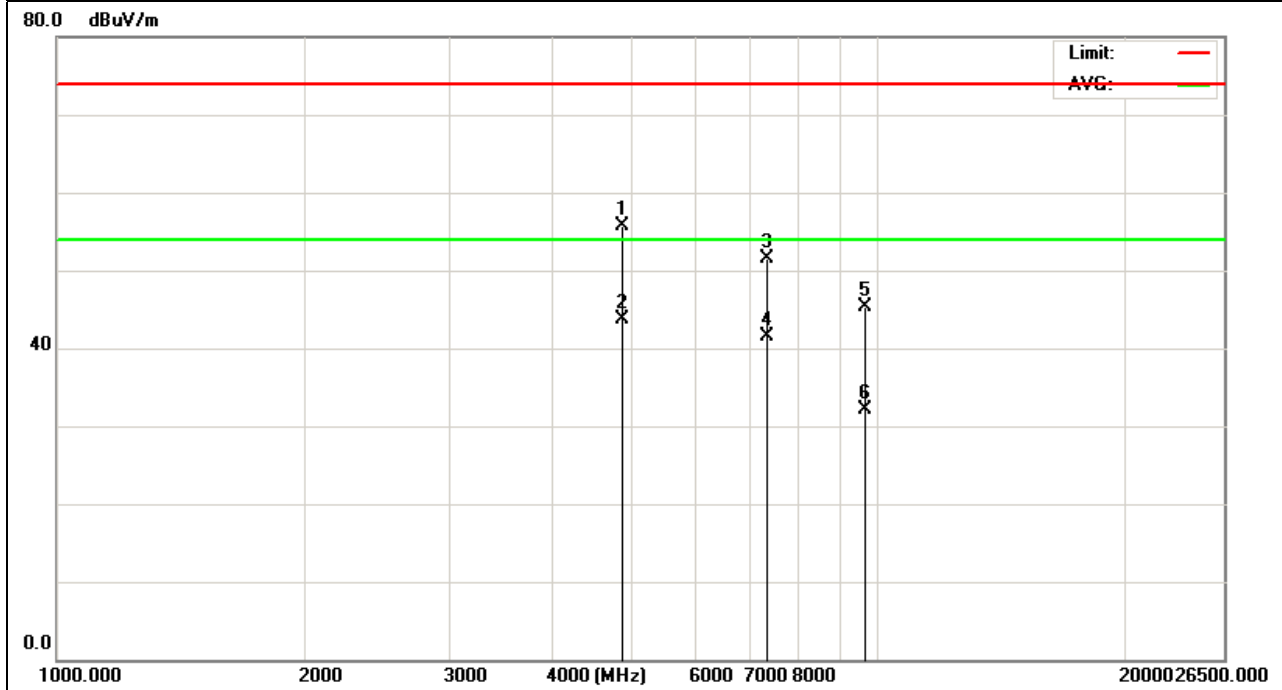

EUT :	IEEE 802.11b/g/n Long Range AP-Router	Model Name :	AIP-W525H
Temperature :	20 °C	Relative Humidity :	48%
Pressure :	1010 hPa	Test Voltage :	DC 12V
Test Mode :	CH6(802.11n Mode)/20MHz (A+B)Antenna	Polarization :	Vertical

Frequency (MHz)	Meter Reading (dBμV)	Factor (dB)	Emission Level (dBμV/m)	Limits (dBμV/m)	Margin (dB)	Detector Type
4874.33	42.86	10.4	53.26	74	-20.74	peak
4874.33	31.79	10.4	42.19	54	-11.81	AVG
7311.84	37.94	12.75	50.69	74	-23.31	peak
7311.84	27.56	12.75	40.31	54	-13.69	AVG
9648.23	29.3	15.67	44.97	74	-29.03	peak
9648.23	22.52	15.67	38.19	54	-15.81	AVG

Remark:
Factor = Antenna Factor + Cable Loss – Pre-amplifier.

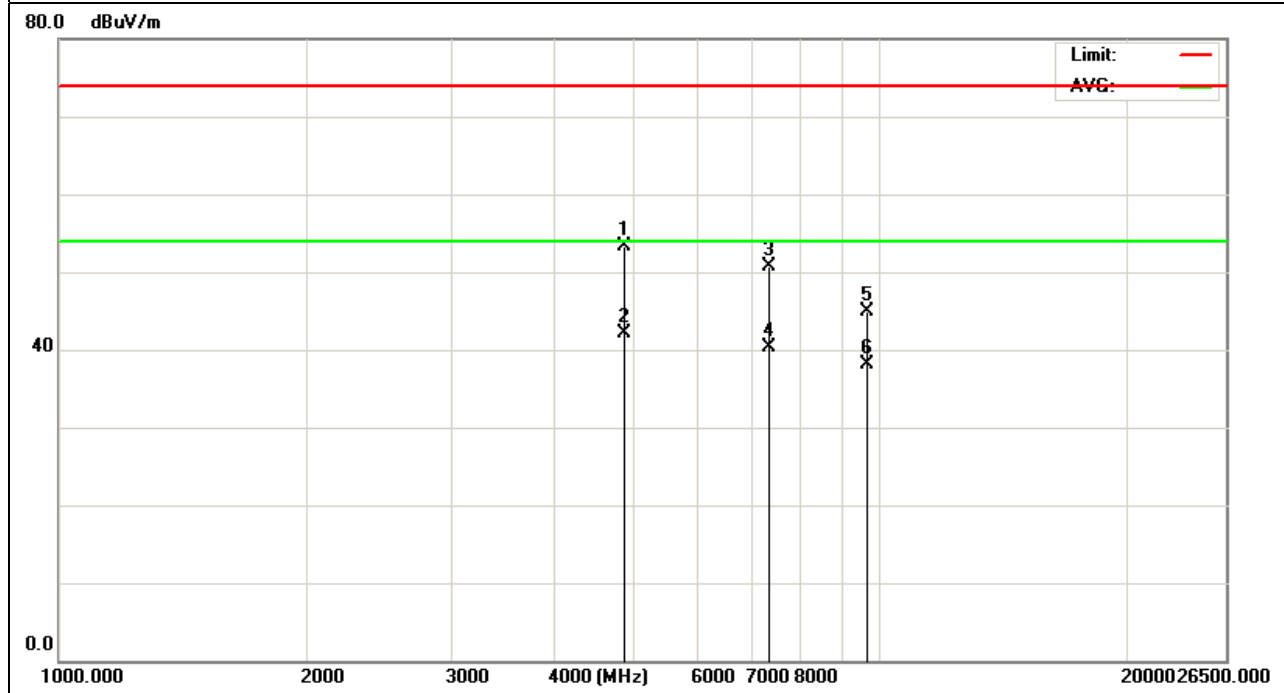

EUT :	IEEE 802.11b/g/n Long Range AP-Router	Model Name :	AIP-W525H
Temperature :	20 °C	Relative Humidity :	48%
Pressure :	1010 hPa	Test Voltage :	DC 12V
Test Mode :	CH11(802.11n Mode)/20MHz (A+B)Antenna	Polarization :	Horizontal

Frequency (MHz)	Meter Reading (dBμV)	Factor (dB)	Emission Level (dBμV/m)	Limits (dBμV/m)	Margin (dB)	Detector Type
4924.11	42.87	10.39	53.26	74	-20.74	peak
4924.11	31.8	10.39	42.19	54	-11.81	AVG
7386.19	38.01	12.68	50.69	74	-23.31	peak
7386.19	27.63	12.68	40.31	54	-13.69	AVG
9848.95	29.04	15.93	44.97	74	-29.03	peak
9848.95	22.26	15.93	38.19	54	-15.81	AVG

Remark:
Factor = Antenna Factor + Cable Loss – Pre-amplifier.

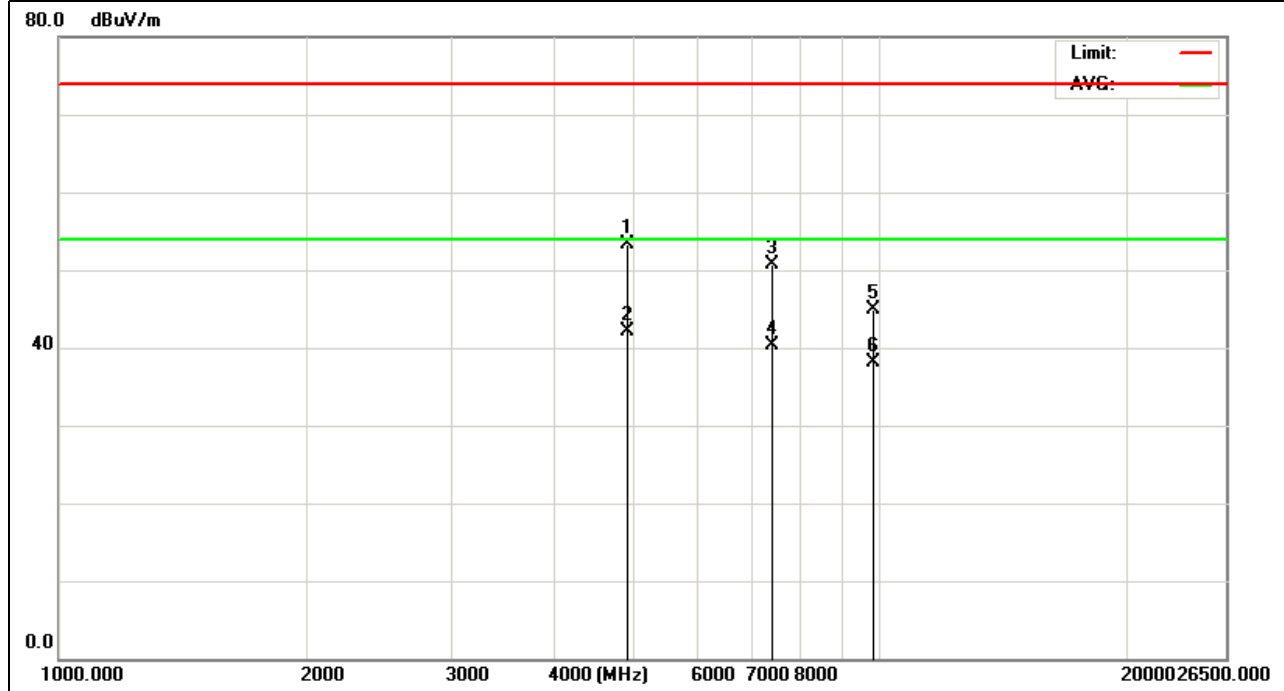

EUT :	IEEE 802.11b/g/n Long Range AP-Router	Model Name :	AIP-W525H
Temperature :	20 °C	Relative Humidity :	48%
Pressure :	1010 hPa	Test Voltage :	DC 12V
Test Mode :	CH11(802.11n Mode)/20MHz (A+B)Antenna	Polarization :	Vertical

Frequency (MHz)	Meter Reading (dBμV)	Factor (dB)	Emission Level (dBμV/m)	Limits (dBμV/m)	Margin (dB)	Detector Type
4924.11	39.62	10.39	50.01	74	-23.99	peak
4924.11	28.99	10.39	39.38	54	-14.62	AVG
7386.19	35.26	12.68	47.94	74	-26.06	peak
7386.19	24.7	12.68	37.38	54	-16.62	AVG
9848.95	26.23	15.93	42.16	74	-31.84	peak
9848.95	18.23	15.93	34.16	54	-19.84	AVG

Remark:
Factor = Antenna Factor + Cable Loss – Pre-amplifier.

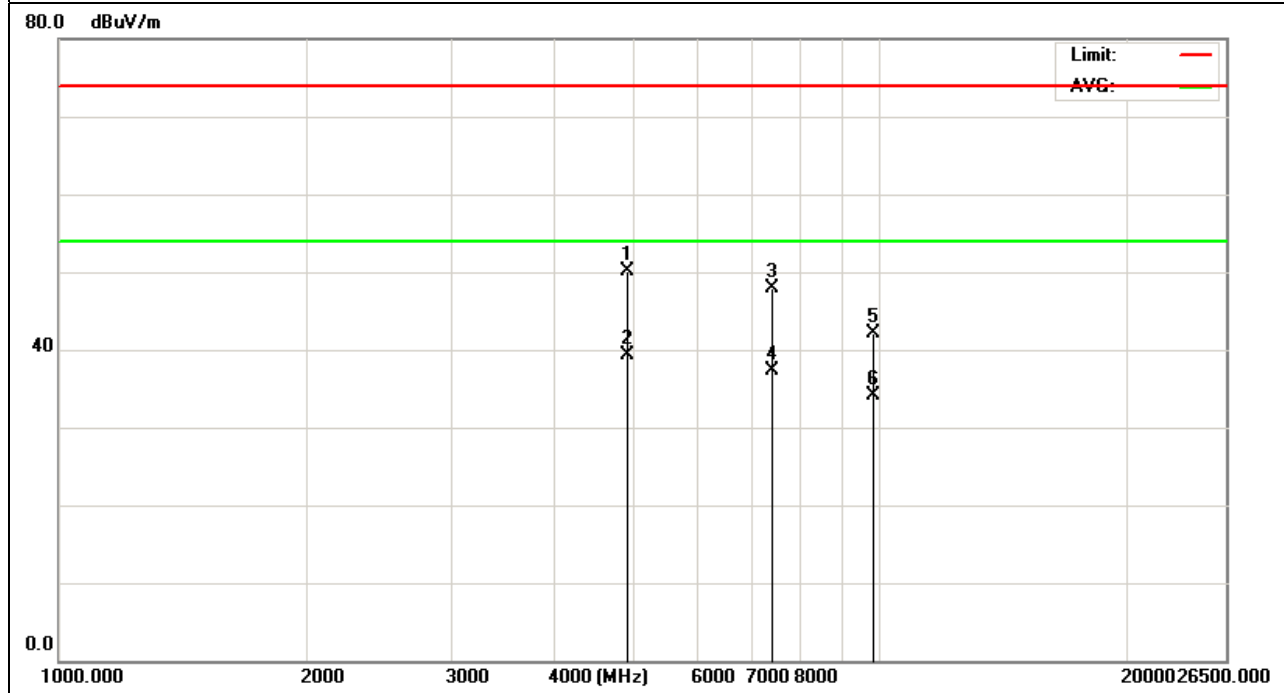

EUT :	IEEE 802.11b/g/n Long Range AP-Router	Model Name :	AIP-W525H
Temperature :	20 °C	Relative Humidity :	48%
Pressure :	1010 hPa	Test Voltage :	DC 12V
Test Mode :	CH3(802.11n Mode)/40MHz (A+B)Antenna	Polarization :	Horizontal

Frequency (MHz)	Meter Reading (dBµV)	Factor (dB)	Emission Level (dBµV/m)	Limits (dBµV/m)	Margin (dB)	Detector Type
4844.45	35.15	10.5	45.65	54	-8.35	AVG
4844.54	48.69	10.5	59.19	74	-14.81	peak
7266.95	38.17	12.5	50.67	74	-23.33	peak
7266.95	28.92	12.5	41.42	54	-12.58	AVG
9688.26	29.98	15.99	45.97	74	-28.03	peak
9688.26	23.39	15.99	39.38	54	-14.62	AVG

Remark:
Factor = Antenna Factor + Cable Loss – Pre-amplifier.

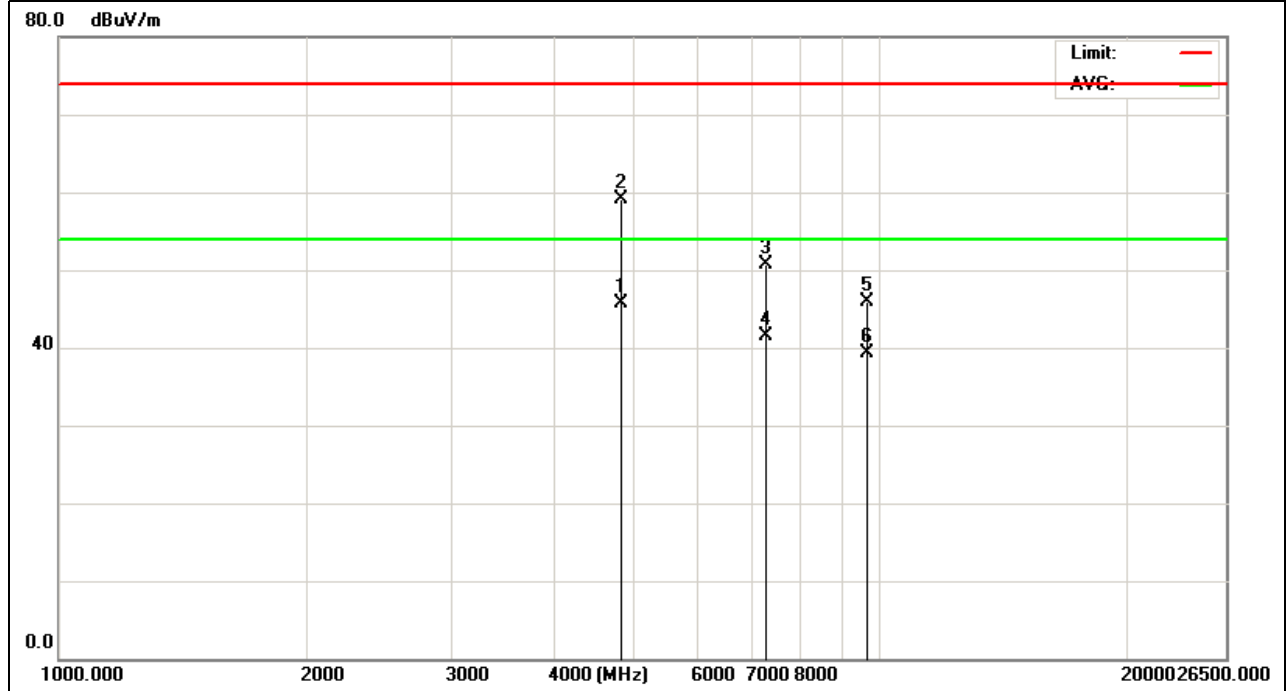

EUT :	IEEE 802.11b/g/n Long Range AP-Router	Model Name :	AIP-W525H
Temperature :	20 °C	Relative Humidity :	48%
Pressure :	1010 hPa	Test Voltage :	DC 12V
Test Mode :	CH3(802.11n Mode)/40MHz (A+B)Antenna	Polarization :	Vertical

Frequency (MHz)	Meter Reading (dBµV)	Factor (dB)	Emission Level (dBµV/m)	Limits (dBµV/m)	Margin (dB)	Detector Type
4844.45	30.66	10.5	41.16	54	-12.84	AVG
4844.54	48.76	10.5	59.26	74	-14.74	peak
7266.95	42.17	12.5	54.67	74	-19.33	peak
7266.95	27.44	12.5	39.94	54	-14.06	AVG
9688.26	28.49	15.99	44.48	74	-29.52	peak
9688.26	21.7	15.99	37.69	54	-16.31	AVG

Remark:
Factor = Antenna Factor + Cable Loss – Pre-amplifier.

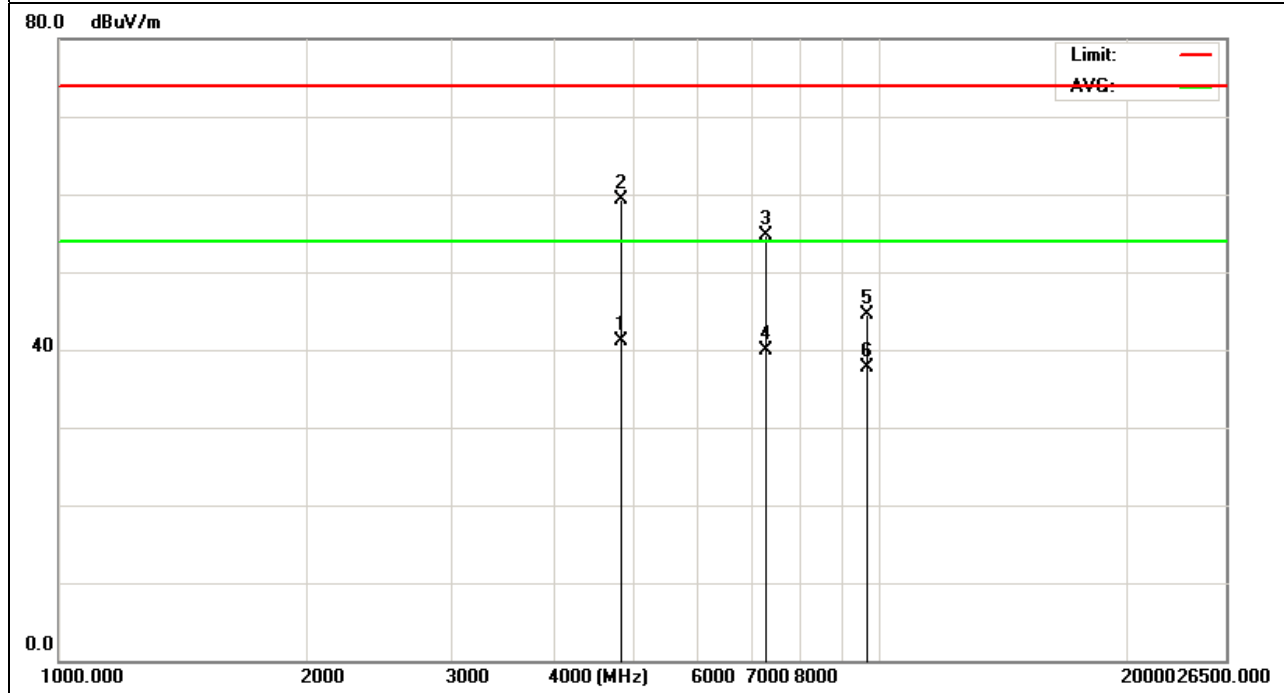

EUT :	IEEE 802.11b/g/n Long Range AP-Router	Model Name :	AIP-W525H
Temperature :	20 °C	Relative Humidity :	48%
Pressure :	1010 hPa	Test Voltage :	DC 12V
Test Mode :	CH6(802.11n Mode)/40MHz (A+B)Antenna	Polarization :	Horizontal

Frequency (MHz)	Meter Reading (dBµV)	Factor (dB)	Emission Level (dBµV/m)	Limits (dBµV/m)	Margin (dB)	Detector Type
4874.33	45.86	10.4	56.26	74	-17.74	peak
4874.33	34.79	10.4	45.19	54	-8.81	AVG
7311.84	39.79	12.75	52.54	74	-21.46	peak
7311.84	29.92	12.75	42.67	54	-11.33	AVG
9648.23	33.51	15.67	49.18	74	-24.82	peak
9648.23	22.62	15.67	38.29	54	-15.71	AVG

Remark:
Factor = Antenna Factor + Cable Loss – Pre-amplifier.

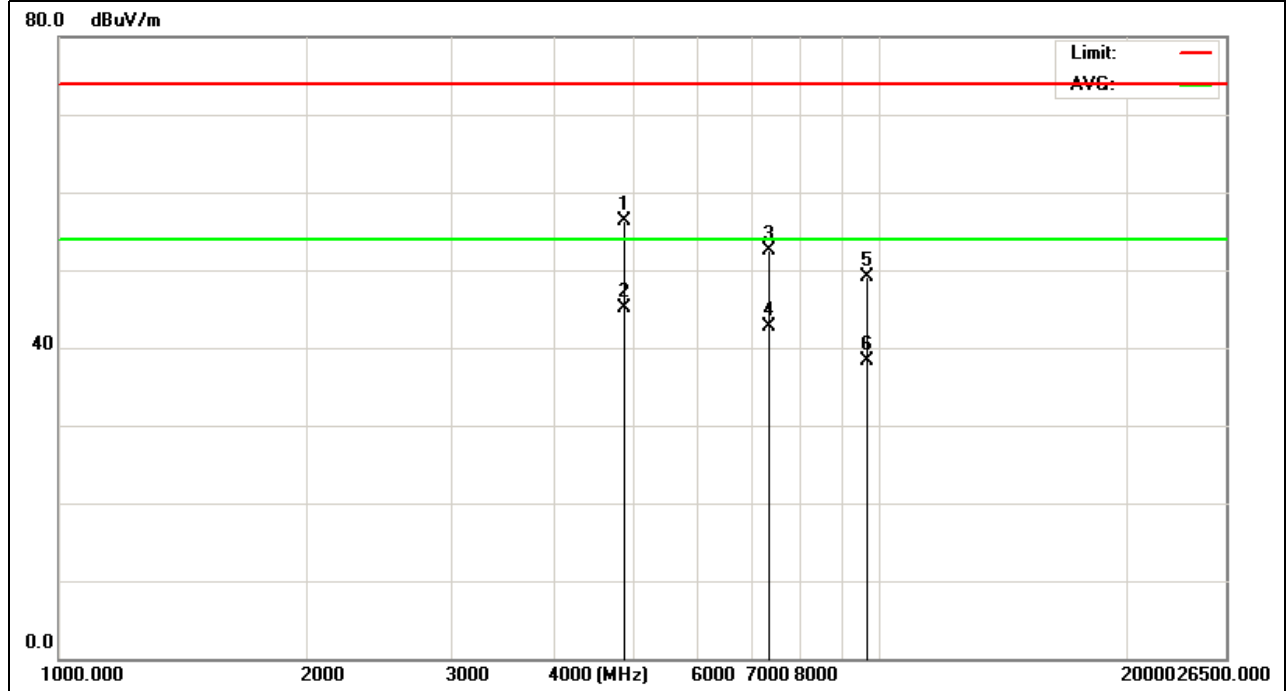

EUT :	IEEE 802.11b/g/n Long Range AP-Router	Model Name :	AIP-W525H
Temperature :	20 °C	Relative Humidity :	48%
Pressure :	1010 hPa	Test Voltage :	DC 12V
Test Mode :	CH6(802.11n Mode)/40MHz (A+B)Antenna	Polarization :	Vertical

Frequency (MHz)	Meter Reading (dBμV)	Factor (dB)	Emission Level (dBμV/m)	Limits (dBμV/m)	Margin (dB)	Detector Type
4874.33	44.57	10.4	54.97	74	-19.03	peak
4874.33	34.57	10.4	44.97	54	-9.03	AVG
7311.84	38.44	12.75	51.19	74	-22.81	peak
7311.84	29.72	12.75	42.47	54	-11.53	AVG
9648.23	29.3	15.67	44.97	74	-29.03	peak
9648.23	23.51	15.67	39.18	54	-14.82	AVG

Remark:
Factor = Antenna Factor + Cable Loss – Pre-amplifier.

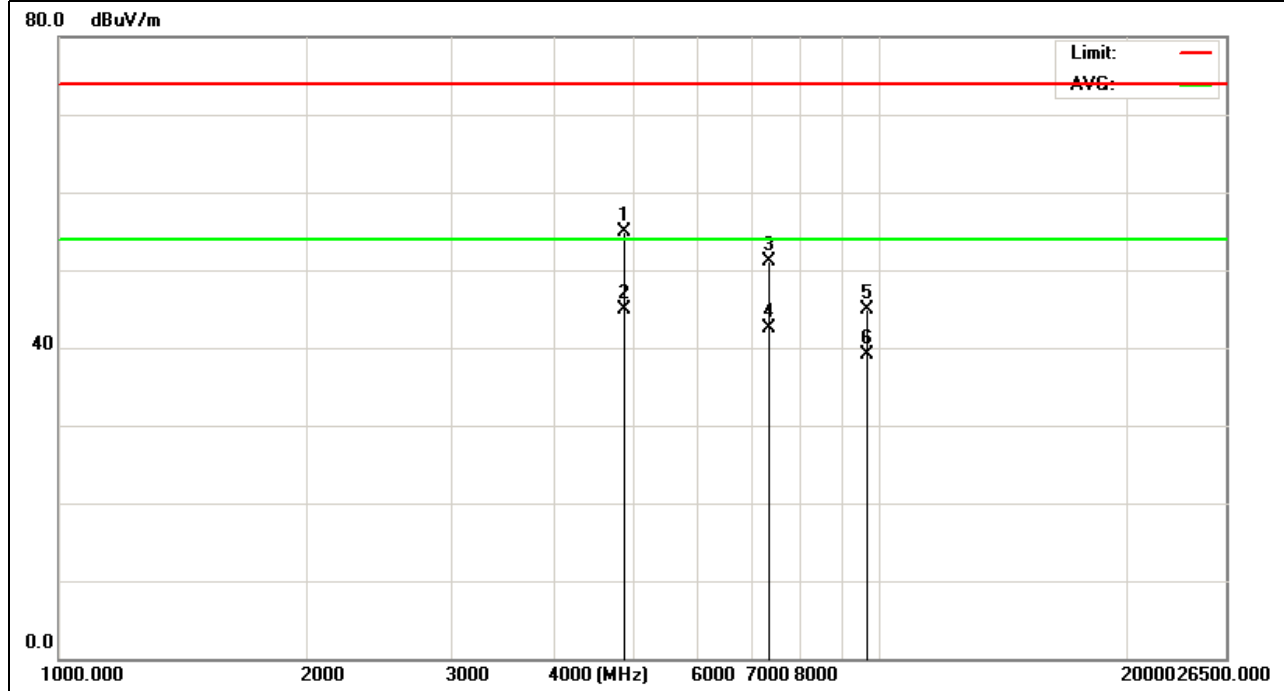

EUT :	IEEE 802.11b/g/n Long Range AP-Router	Model Name :	AIP-W525H
Temperature :	20 °C	Relative Humidity :	48%
Pressure :	1010 hPa	Test Voltage :	DC 12V
Test Mode :	CH9(802.11n Mode)/40MHz (A+B)Antenna	Polarization :	Horizontal

Frequency (MHz)	Meter Reading (dBµV)	Factor (dB)	Emission Level (dBµV/m)	Limits (dBµV/m)	Margin (dB)	Detector Type
4904.18	42.97	10.29	53.26	74	-20.74	peak
4904.18	30.9	10.29	41.19	54	-12.81	AVG
7356.29	38.1	12.79	50.89	74	-23.11	peak
7359.29	28.38	12.79	41.17	54	-12.83	AVG
9808.54	28.86	16.11	44.97	74	-29.03	peak
9808.54	23.07	16.11	39.18	54	-14.82	AVG

Remark:
Factor = Antenna Factor + Cable Loss – Pre-amplifier.

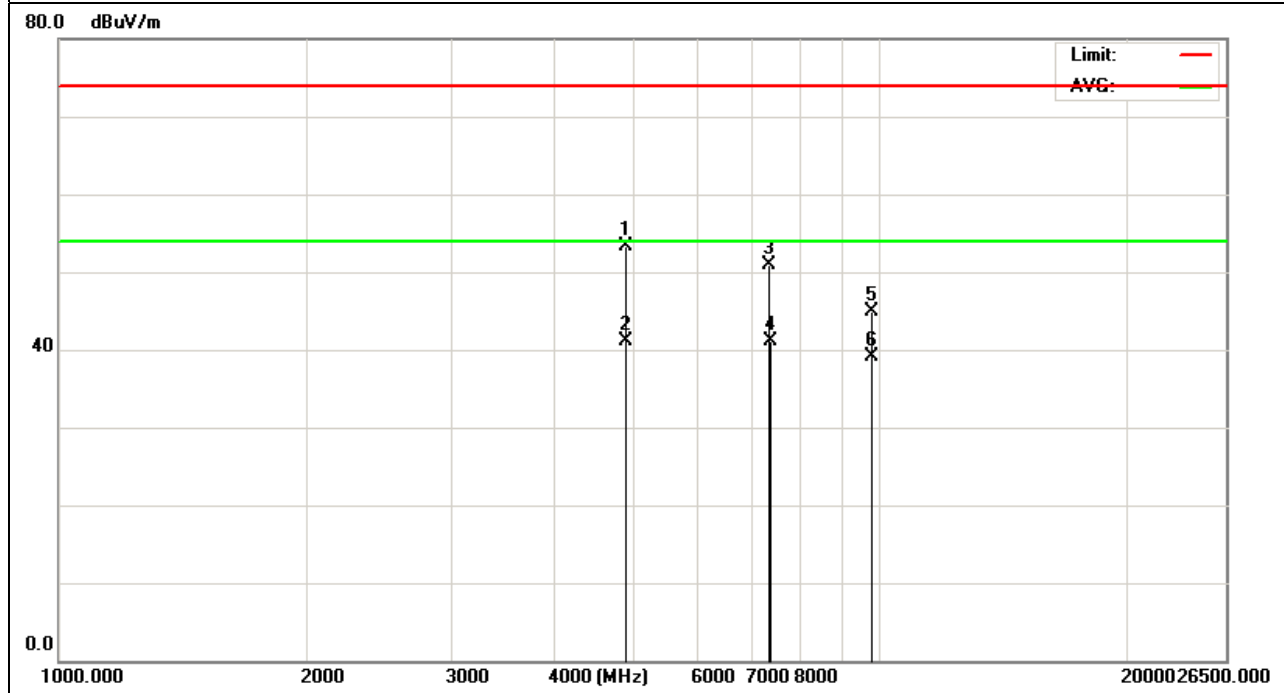

EUT :	IEEE 802.11b/g/n Long Range AP-Router	Model Name :	AIP-W525H
Temperature :	20 °C	Relative Humidity :	48%
Pressure :	1010 hPa	Test Voltage :	DC 12V
Test Mode :	CH9(802.11n Mode)/40MHz (A+B)Antenna	Polarization :	Vertical

Frequency (MHz)	Meter Reading (dBµV)	Factor (dB)	Emission Level (dBµV/m)	Limits (dBµV/m)	Margin (dB)	Detector Type
4904.18	43.82	10.29	54.11	74	-19.89	peak
4904.18	32.35	10.29	42.64	54	-11.36	AVG
7356.29	37.77	12.79	50.56	74	-23.44	peak
7359.29	30.19	12.79	42.98	54	-11.02	AVG
9808.54	29.33	16.11	45.44	74	-28.56	peak
9808.54	24.63	16.11	40.74	54	-13.26	AVG

Remark:
Factor = Antenna Factor + Cable Loss – Pre-amplifier.

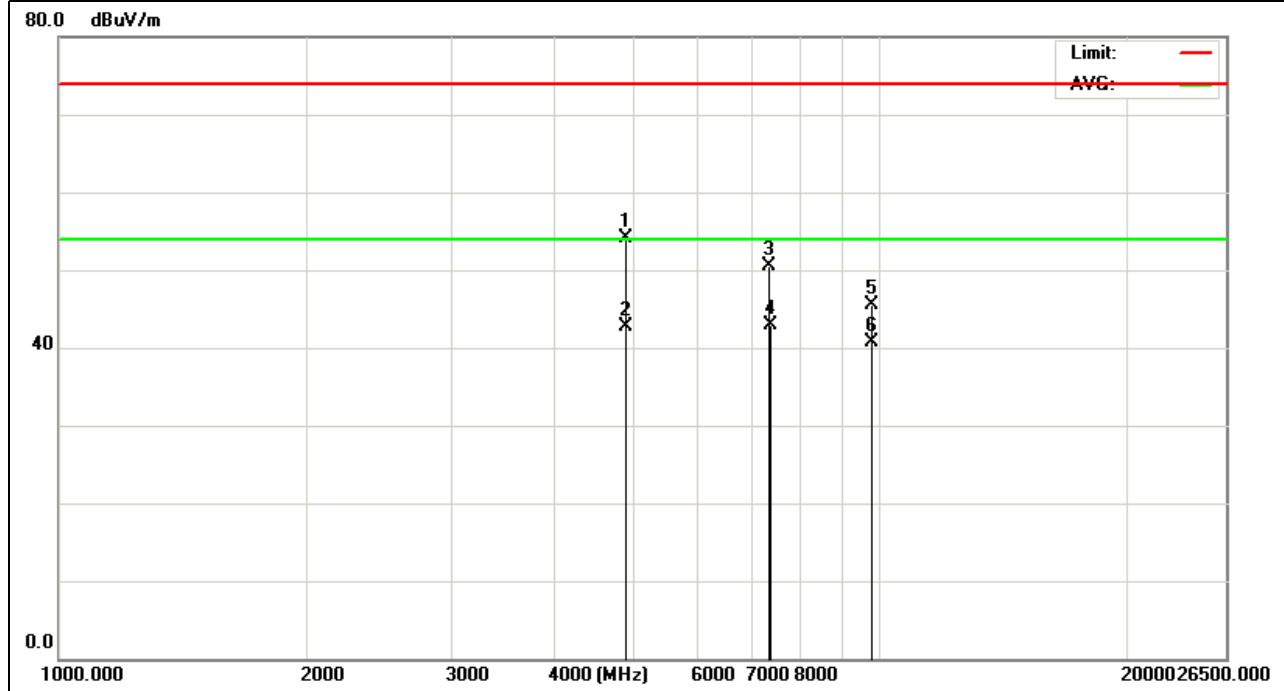

4.BAND EDGE EMISSION

EUT :	IEEE 802.11b/g/n Long Range AP-Router	Model Name :	AIP-W525H
Temperature :	20 °C	Relative Humidity :	48%
Pressure :	1010 hPa	Test Voltage :	DC 12V
Test Mode :	CH1(802.11b Mode)	Polarization :	Horizontal

Frequency (MHz)	Meter Reading (dBµV)	Factor (dB)	Emission Level (dBµV/m)	Limits (dBµV/m)	Margin (dB)	Detector Type
2400	41.18	-0.69	40.49	74	-33.51	peak
2400	37.94	-0.69	37.25	54	-16.75	AVG

Remark:
 Factor = Antenna Factor + Cable Loss – Pre-amplifier.

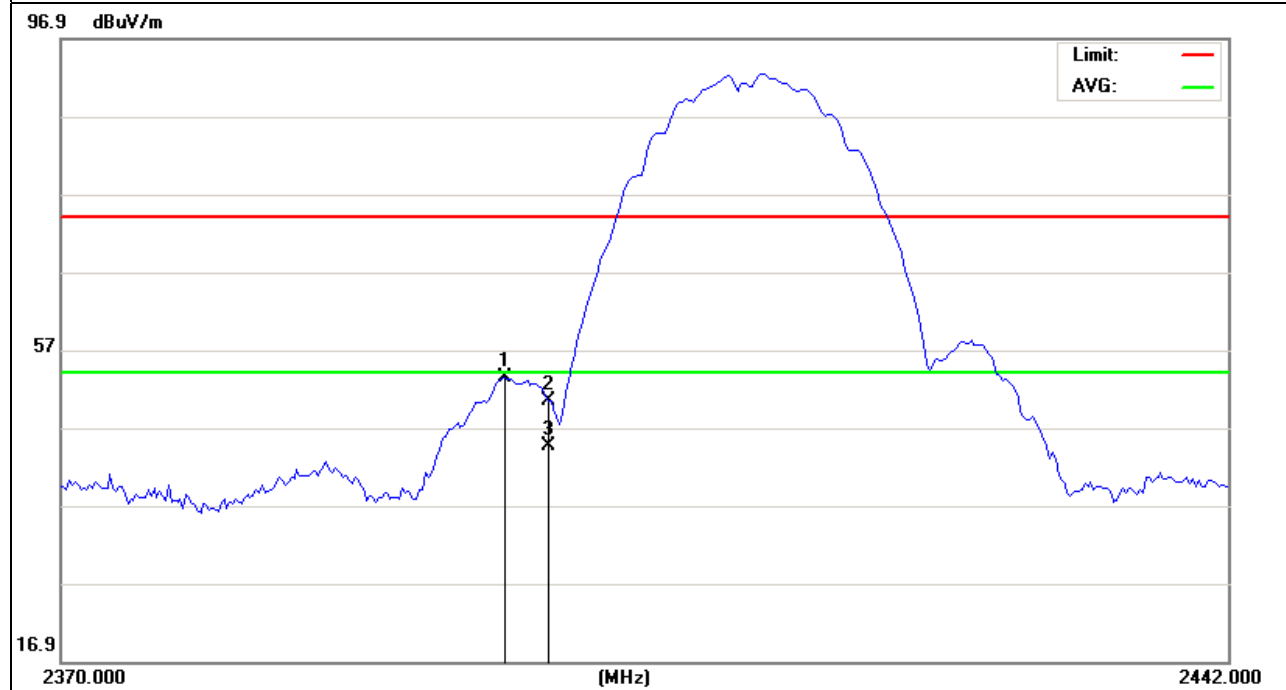

EUT :	IEEE 802.11b/g/n Long Range AP-Router	Model Name :	AIP-W525H
Temperature :	20 °C	Relative Humidity :	48%
Pressure :	1010 hPa	Test Voltage :	DC 12V
Test Mode :	CH1(802.11b Mode)	Polarization :	Vertical

Frequency (MHz)	Meter Reading (dBμV)	Factor (dB)	Emission Level (dBμV/m)	Limits (dBμV/m)	Margin (dB)	Detector Type
2439.12	56.19	-0.69	55.5	74	-18.5	peak
2439.12	40.97	-0.69	40.28	54	-13.72	AVG

Remark:
 Factor = Antenna Factor + Cable Loss – Pre-amplifier.

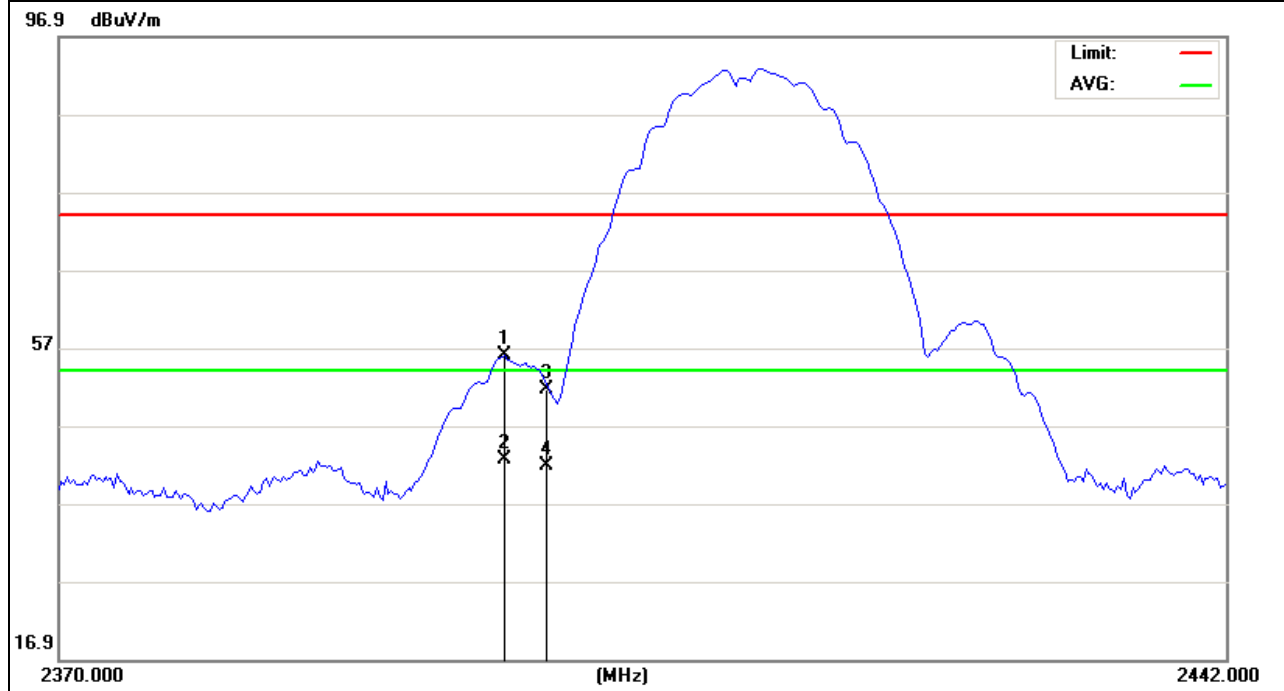

EUT :	IEEE 802.11b/g/n Long Range AP-Router	Model Name :	AIP-W525H
Temperature :	20 °C	Relative Humidity :	48%
Pressure :	1010 hPa	Test Voltage :	DC 12V
Test Mode :	CH11(802.11b Mode)	Polarization :	Horizontal

Frequency (MHz)	Meter Reading (dBμV)	Factor (dB)	Emission Level (dBμV/m)	Limits (dBμV/m)	Margin (dB)	Detector Type
2483.5	41.16	-0.47	40.69	74	-33.31	peak
2483.5	34.11	-0.47	33.64	54	-20.36	AVG

Remark:
 Factor = Antenna Factor + Cable Loss – Pre-amplifier.

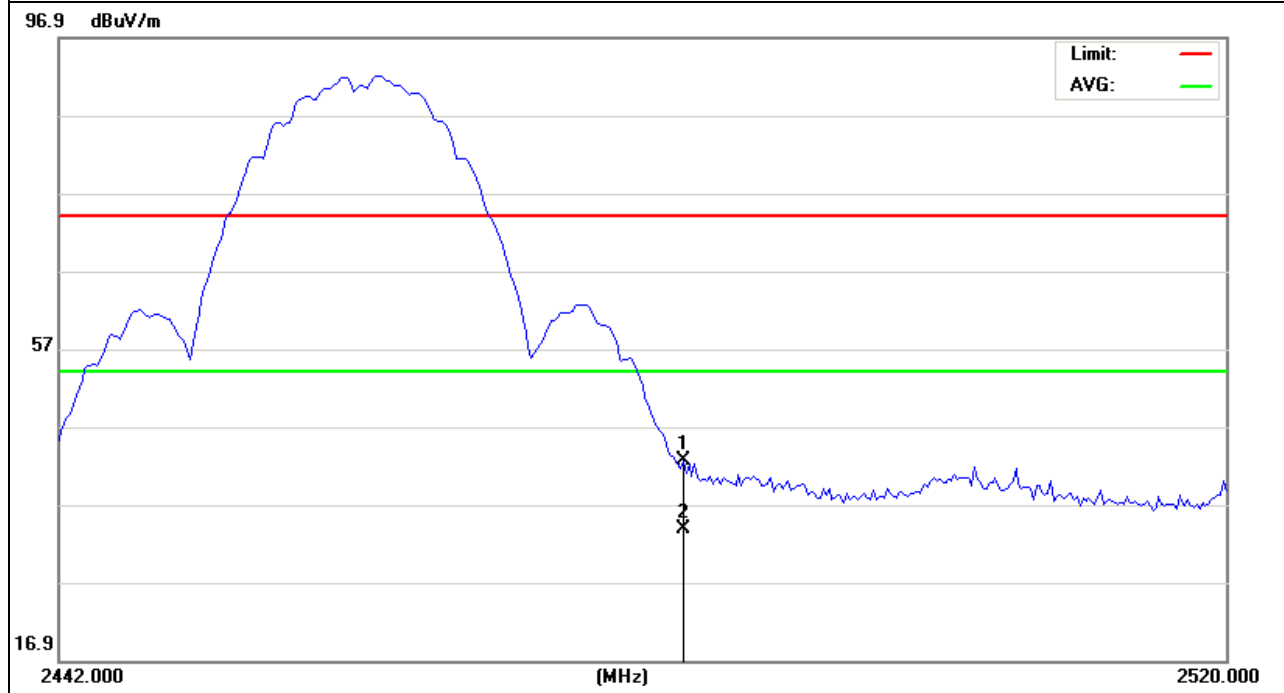

EUT :	IEEE 802.11b/g/n Long Range AP-Router	Model Name :	AIP-W525H
Temperature :	20 °C	Relative Humidity :	48%
Pressure :	1010 hPa	Test Voltage :	DC 12V
Test Mode :	CH11(802.11b Mode)	Polarization :	Vertical

Frequency (MHz)	Meter Reading (dBμV)	Factor (dB)	Emission Level (dBμV/m)	Limits (dBμV/m)	Margin (dB)	Detector Type
2483.5	40.16	-0.47	39.69	74	-34.31	peak
2483.5	33.11	-0.47	32.64	54	-21.36	AVG

Remark:
 Factor = Antenna Factor + Cable Loss – Pre-amplifier.

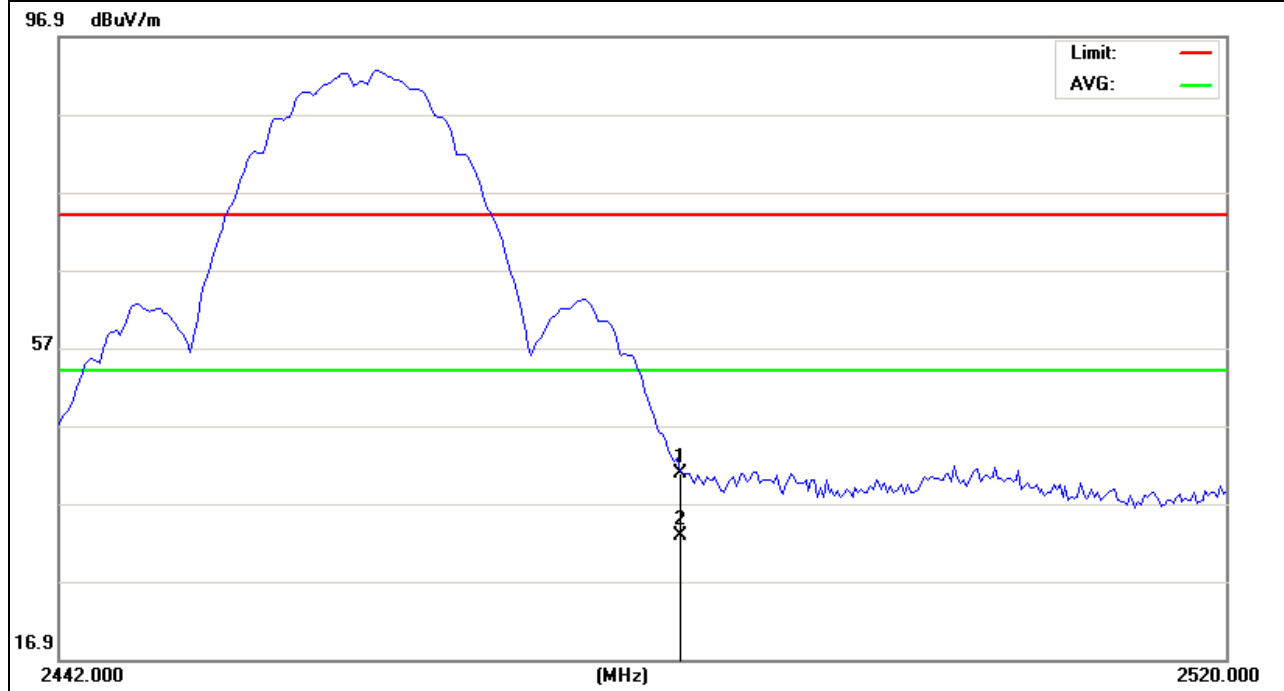

EUT :	IEEE 802.11b/g/n Long Range AP-Router	Model Name :	AIP-W525H
Temperature :	20 °C	Relative Humidity :	48%
Pressure :	1010 hPa	Test Voltage :	DC 12V
Test Mode :	CH1(802.11g Mode)	Polarization :	Horizontal

Frequency (MHz)	Meter Reading (dBμV)	Factor (dB)	Emission Level (dBμV/m)	Limits (dBμV/m)	Margin (dB)	Detector Type
2400	66.94	-0.69	66.25	74	-7.75	peak
2400	48.19	-0.69	47.5	54	-6.5	AVG

Remark:
 Factor = Antenna Factor + Cable Loss – Pre-amplifier.

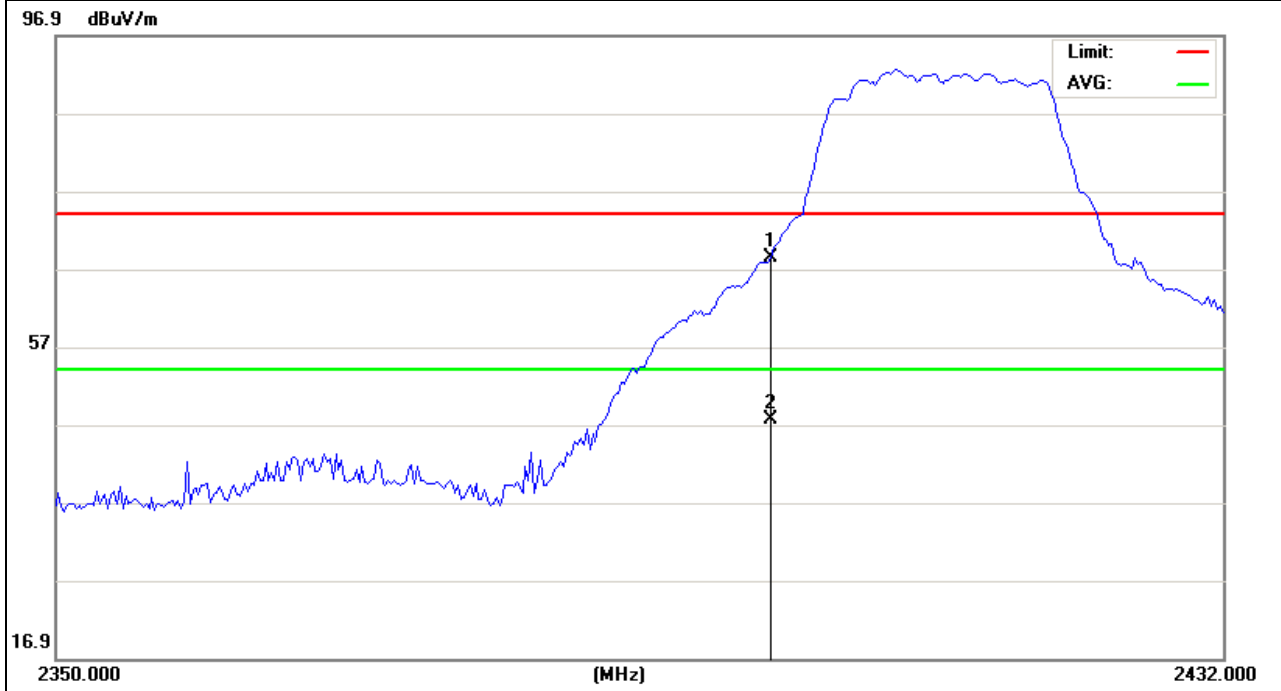

EUT :	IEEE 802.11b/g/n Long Range AP-Router	Model Name :	AIP-W525H
Temperature :	20 °C	Relative Humidity :	48%
Pressure :	1010 hPa	Test Voltage :	DC 12V
Test Mode :	CH1(802.11gMode)	Polarization :	Vertical

Frequency (MHz)	Meter Reading (dBμV)	Factor (dB)	Emission Level (dBμV/m)	Limits (dBμV/m)	Margin (dB)	Detector Type
2400	68.54	-0.69	67.85	74	-6.15	peak
2400	46.68	-0.69	45.99	54	-8.01	AVG

Remark:
 Factor = Antenna Factor + Cable Loss – Pre-amplifier.

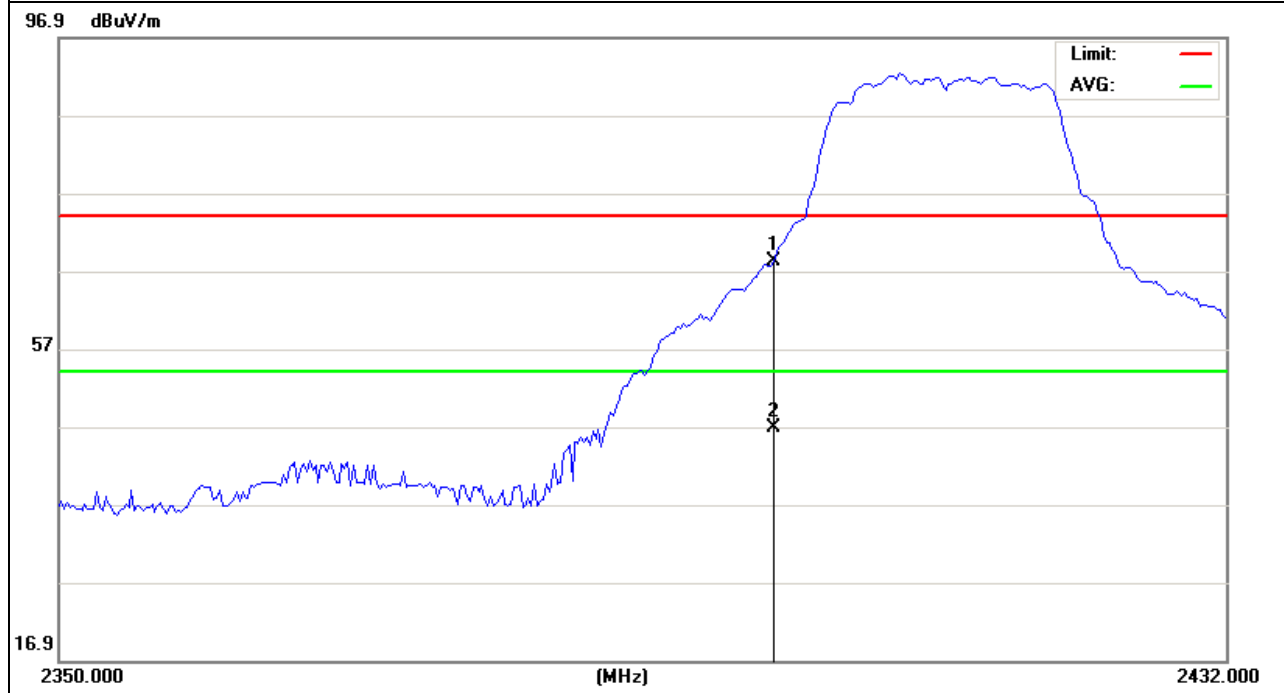

EUT :	IEEE 802.11b/g/n Long Range AP-Router	Model Name :	AIP-W525H
Temperature :	20 °C	Relative Humidity :	48%
Pressure :	1010 hPa	Test Voltage :	DC 12V
Test Mode :	CH11(802.11g Mode)	Polarization :	Horizontal

Frequency (MHz)	Meter Reading (dBμV)	Factor (dB)	Emission Level (dBμV/m)	Limits (dBμV/m)	Margin (dB)	Detector Type
2483.5	62.38	-0.47	61.91	74	-12.09	peak
2483.5	47.24	-0.47	46.77	54	-7.23	AVG

Remark:
 Factor = Antenna Factor + Cable Loss – Pre-amplifier.

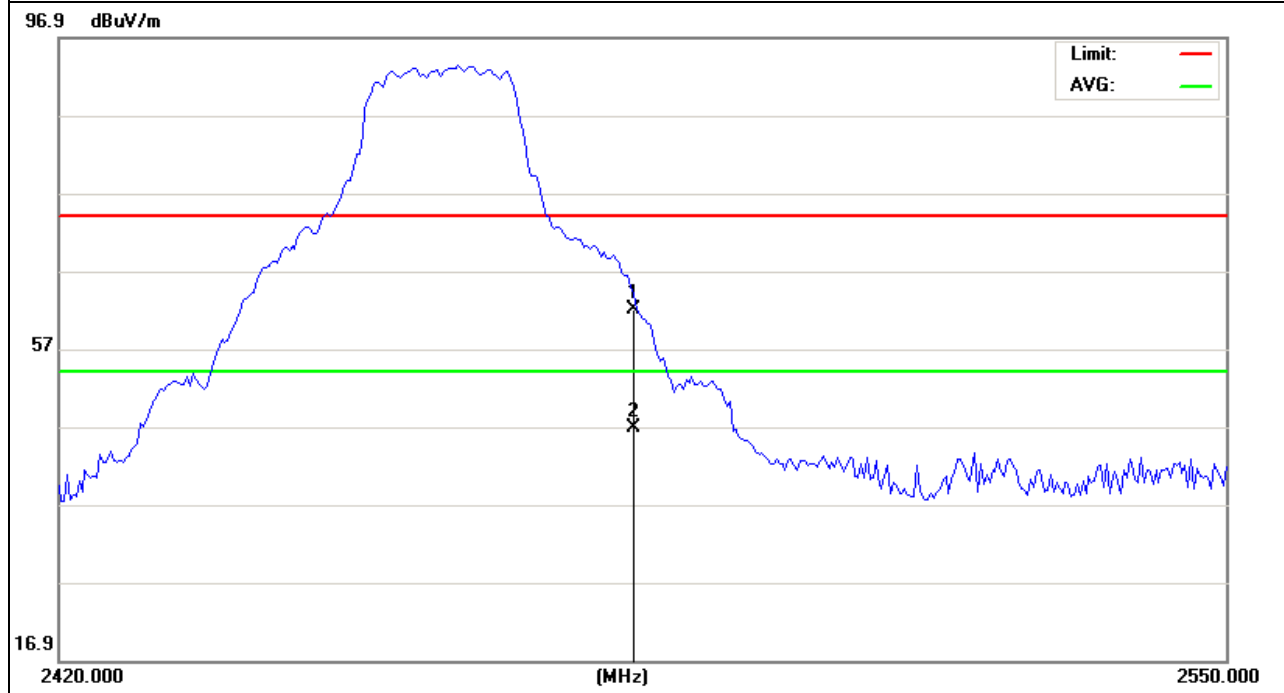

EUT :	IEEE 802.11b/g/n Long Range AP-Router	Model Name :	AIP-W525H
Temperature :	20 °C	Relative Humidity :	48%
Pressure :	1010 hPa	Test Voltage :	DC 12V
Test Mode :	CH11(802.11g Mode)	Polarization :	Vertical

Frequency (MHz)	Meter Reading (dBμV)	Factor (dB)	Emission Level (dBμV/m)	Limits (dBμV/m)	Margin (dB)	Detector Type
2483.5	63.3	-0.47	62.83	74	-11.17	peak
2483.5	48.27	-0.47	47.8	54	-6.2	AVG

Remark:
 Factor = Antenna Factor + Cable Loss – Pre-amplifier.

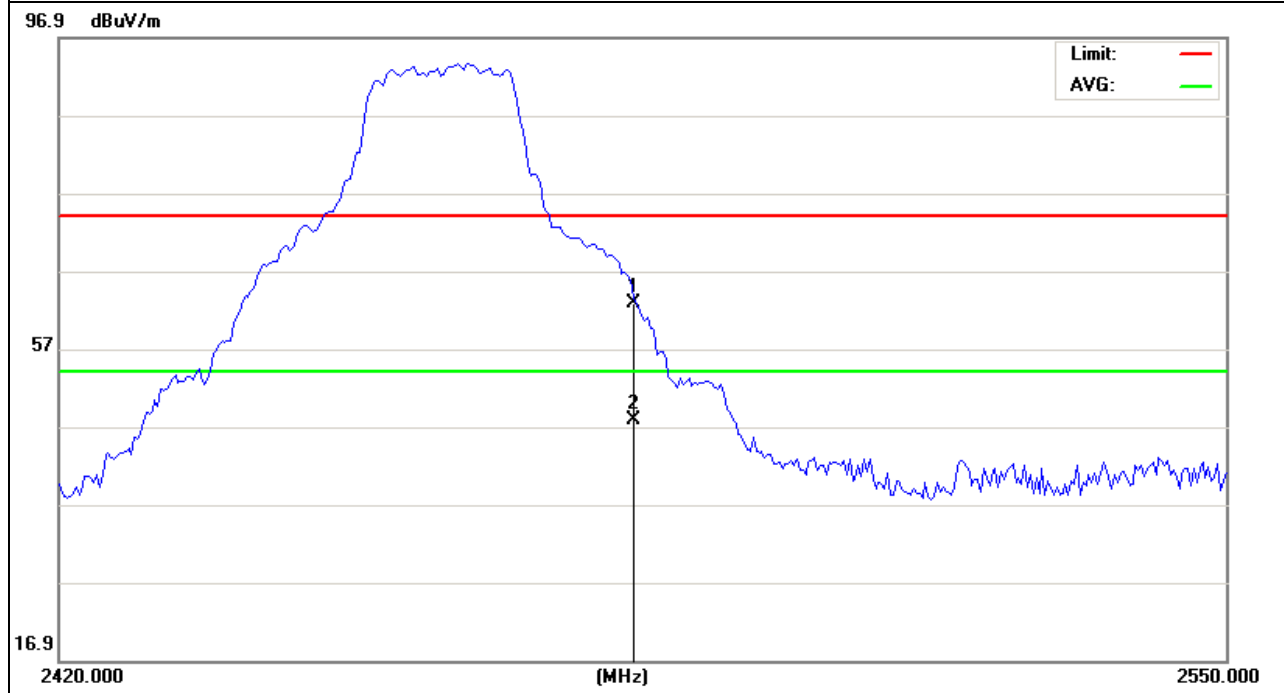

EUT :	IEEE 802.11b/g/n Long Range AP-Router	Model Name :	AIP-W525H
Temperature :	20 °C	Relative Humidity :	48%
Pressure :	1010 hPa	Test Voltage :	DC 12V
Test Mode :	CH1(802.11N Mode)/20MHz (A+B)Antenna	Polarization :	Horizontal

Frequency (MHz)	Meter Reading (dBμV)	Factor (dB)	Emission Level (dBμV/m)	Limits (dBμV/m)	Margin (dB)	Detector Type
2400	69.37	-0.69	68.68	74	-5.32	peak
2400	49.66	-0.69	48.97	54	-5.03	AVG

Remark:
Factor = Antenna Factor + Cable Loss – Pre-amplifier.

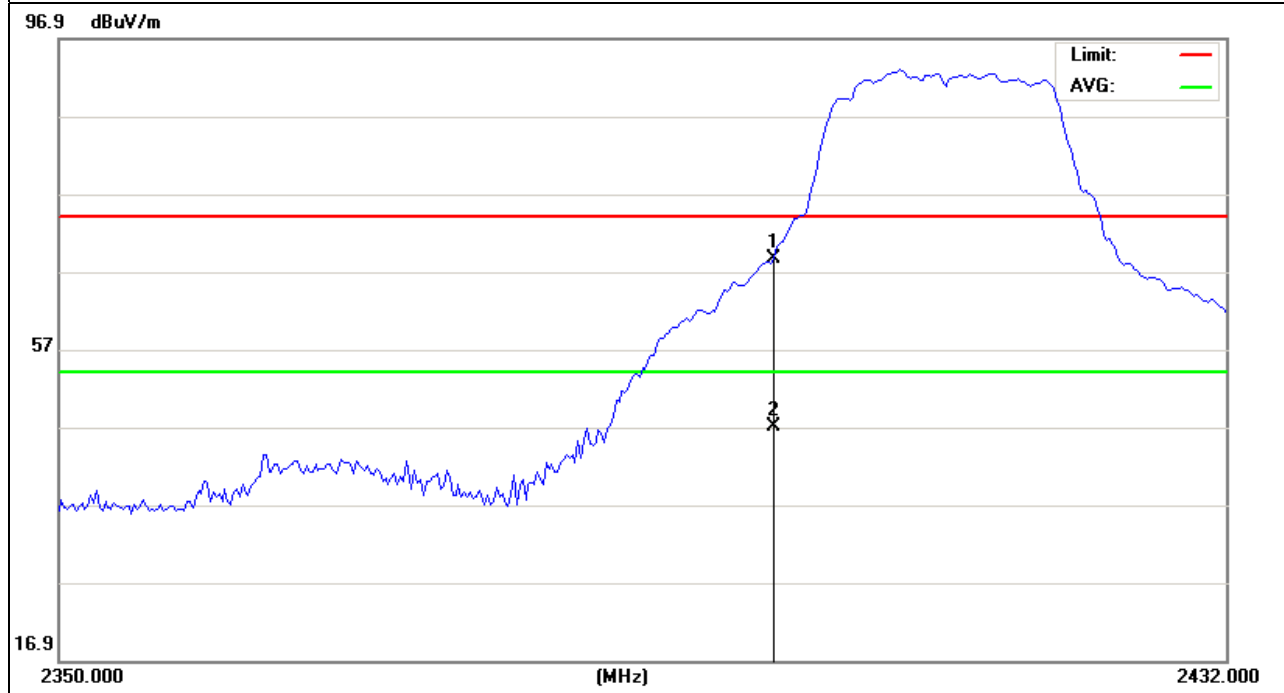

EUT :	IEEE 802.11b/g/n Long Range AP-Router	Model Name :	AIP-W525H
Temperature :	20 °C	Relative Humidity :	48%
Pressure :	1010 hPa	Test Voltage :	DC 12V
Test Mode :	CH1(802.11N Mode)/20MHz (A+B)Antenna	Polarization :	Vertical

Frequency (MHz)	Meter Reading (dBμV)	Factor (dB)	Emission Level (dBμV/m)	Limits (dBμV/m)	Margin (dB)	Detector Type
2400	69.37	-0.69	68.68	74	-5.32	peak
2400	48.88	-0.69	48.19	54	-5.81	AVG

Remark:
Factor = Antenna Factor + Cable Loss – Pre-amplifier.

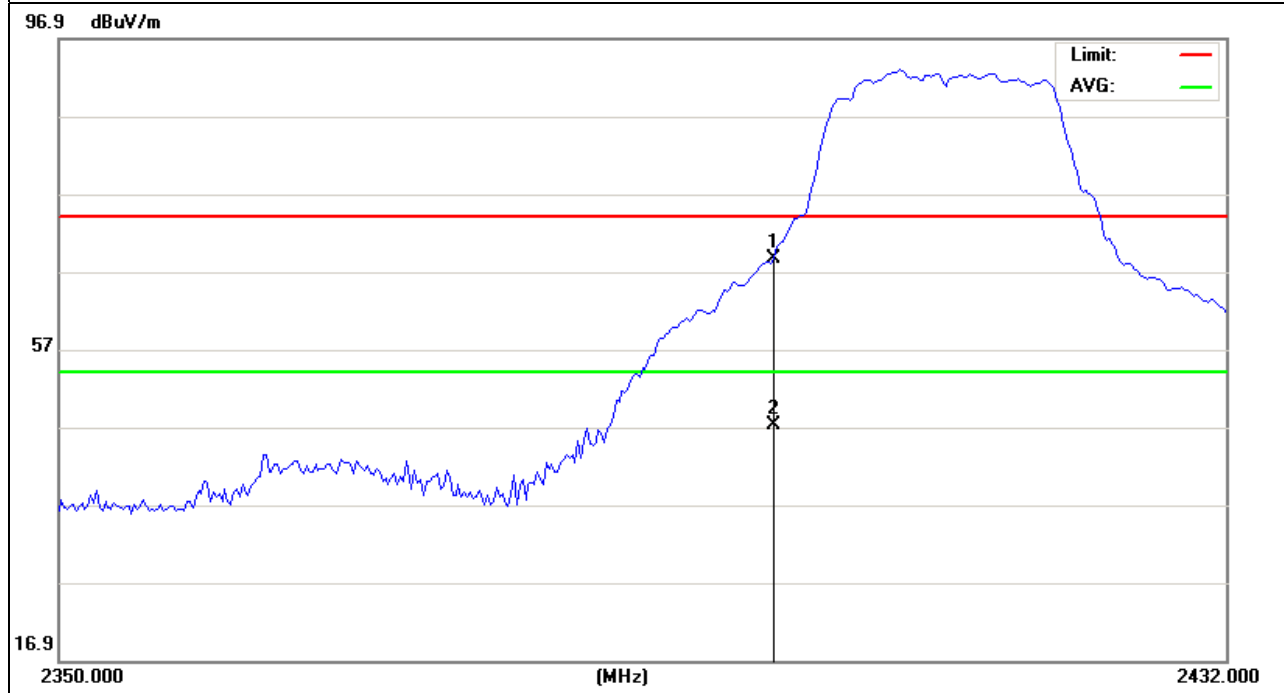

EUT :	IEEE 802.11b/g/n Long Range AP-Router	Model Name :	AIP-W525H
Temperature :	20 °C	Relative Humidity :	48%
Pressure :	1010 hPa	Test Voltage :	DC 12V
Test Mode :	CH11(802.11N Mode)/20MHz (A+B)Antenna	Polarization :	Horizontal

Frequency (MHz)	Meter Reading (dBμV)	Factor (dB)	Emission Level (dBμV/m)	Limits (dBμV/m)	Margin (dB)	Detector Type
2483.5	65.03	-0.47	64.56	74	-9.44	peak
2483.5	47.12	-0.47	46.65	54	-7.35	AVG

Remark:
Factor = Antenna Factor + Cable Loss – Pre-amplifier.

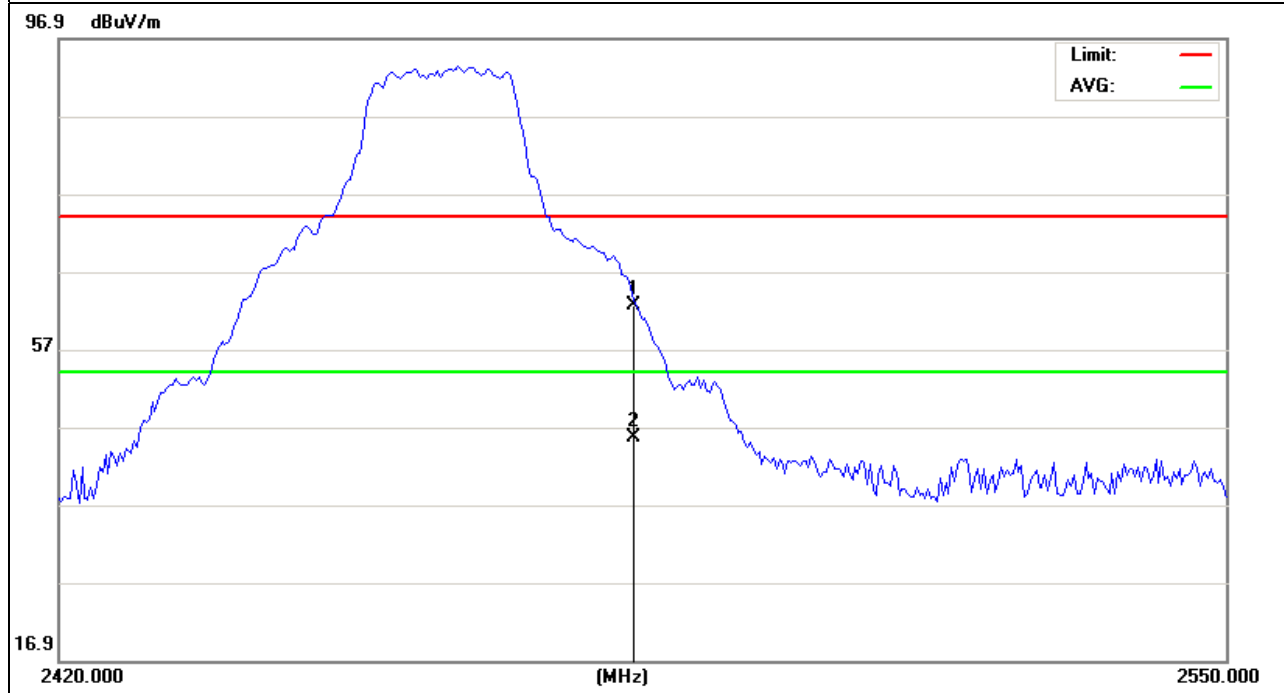

EUT :	IEEE 802.11b/g/n Long Range AP-Router	Model Name :	AIP-W525H
Temperature :	20 °C	Relative Humidity :	48%
Pressure :	1010 hPa	Test Voltage :	DC 12V
Test Mode :	CH11(802.11N Mode)/20MHz (A+B)Antenna	Polarization :	Vertical

Frequency (MHz)	Meter Reading (dBμV)	Factor (dB)	Emission Level (dBμV/m)	Limits (dBμV/m)	Margin (dB)	Detector Type
2483.5	64.33	-0.47	63.86	74	-10.14	peak
2483.5	47.29	-0.47	46.82	54	-7.18	AVG

Remark:
Factor = Antenna Factor + Cable Loss – Pre-amplifier.

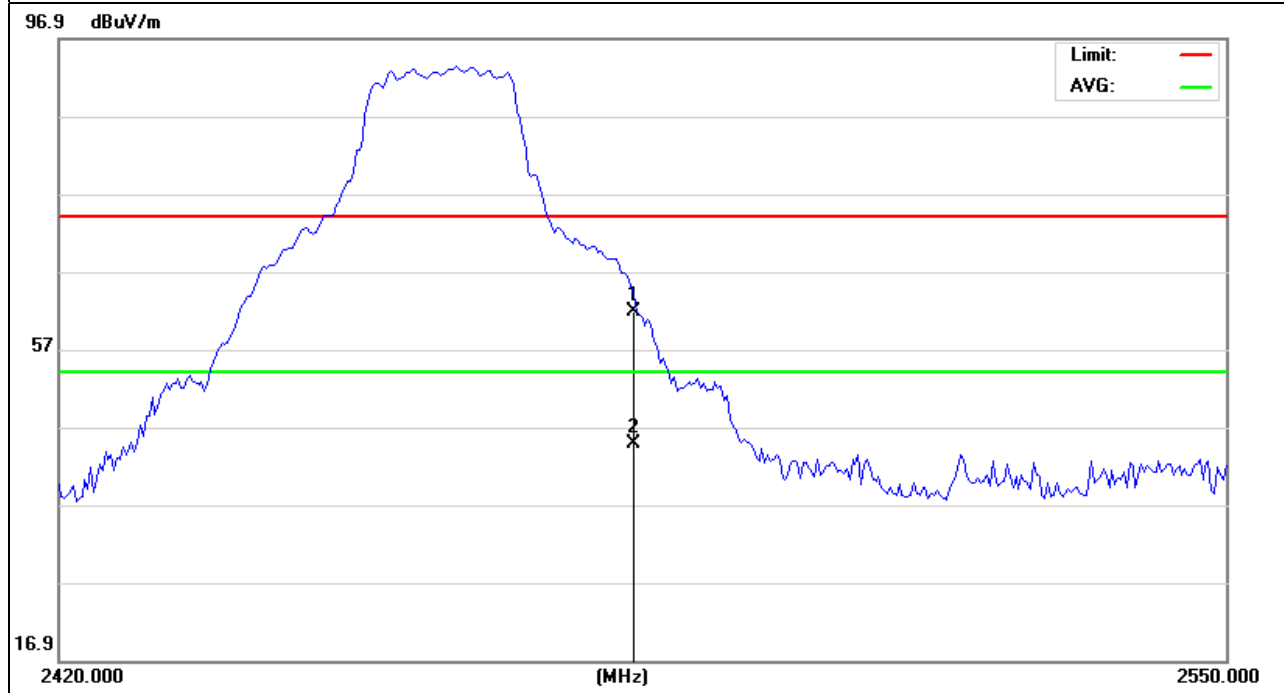

EUT :	IEEE 802.11b/g/n Long Range AP-Router	Model Name :	AIP-W525H
Temperature :	20 °C	Relative Humidity :	48%
Pressure :	1010 hPa	Test Voltage :	DC 12V
Test Mode :	CH3(802.11n Mode)/40M (A+B)Antenna	Polarization :	Horizontal

Frequency (MHz)	Meter Reading (dBμV)	Factor (dB)	Emission Level (dBμV/m)	Limits (dBμV/m)	Margin (dB)	Detector Type
2400	83.86	-0.47	66.4	74	-7.6	peak
2400	65.25	-0.47	47.79	54	-7.21	AVG

Remark:
 Factor = Antenna Factor + Cable Loss – Pre-amplifier.

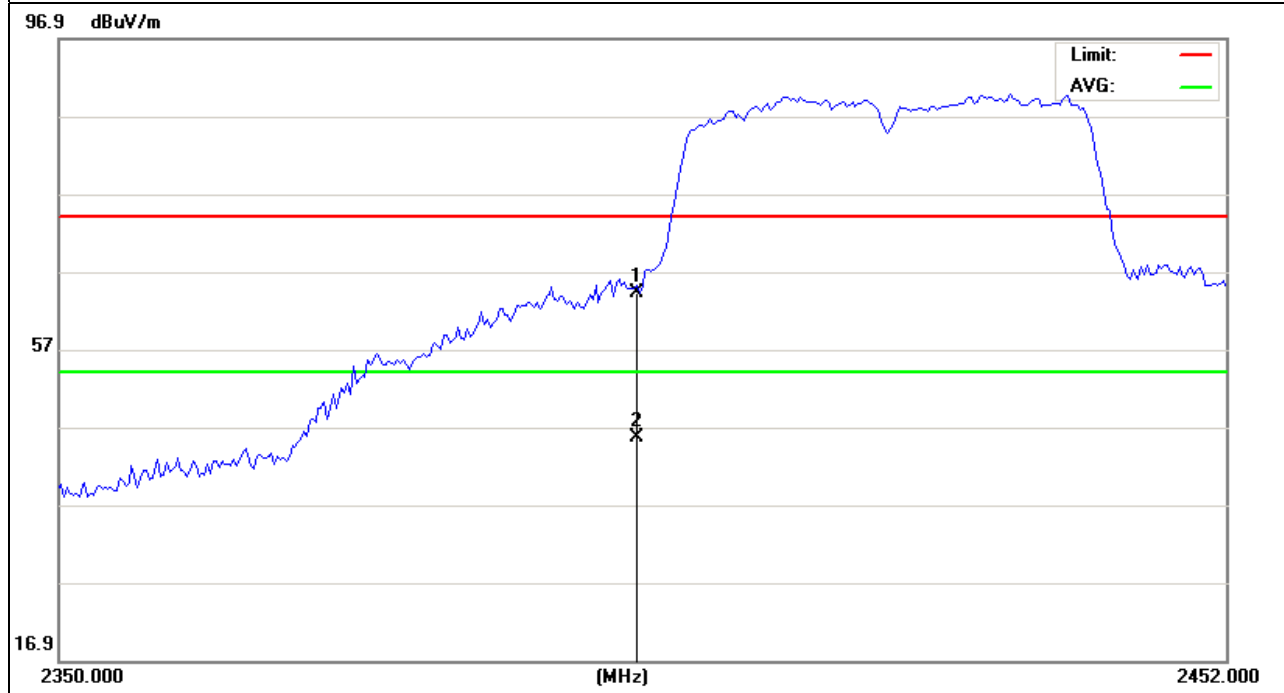

EUT :	IEEE 802.11b/g/n Long Range AP-Router	Model Name :	AIP-W525H
Temperature :	20 °C	Relative Humidity :	48%
Pressure :	1010 hPa	Test Voltage :	DC 12V
Test Mode :	CH3(802.11n Mode)/40M (A+B)Antenna	Polarization :	Vertical

Frequency (MHz)	Meter Reading (dBμV)	Factor (dB)	Emission Level (dBμV/m)	Limits (dBμV/m)	Margin (dB)	Detector Type
2483.5	67.47	-0.47	67	74	-7	peak
2483.5	47.12	-0.47	46.65	54	-7.35	AVG

Remark:
Factor = Antenna Factor + Cable Loss – Pre-amplifier.

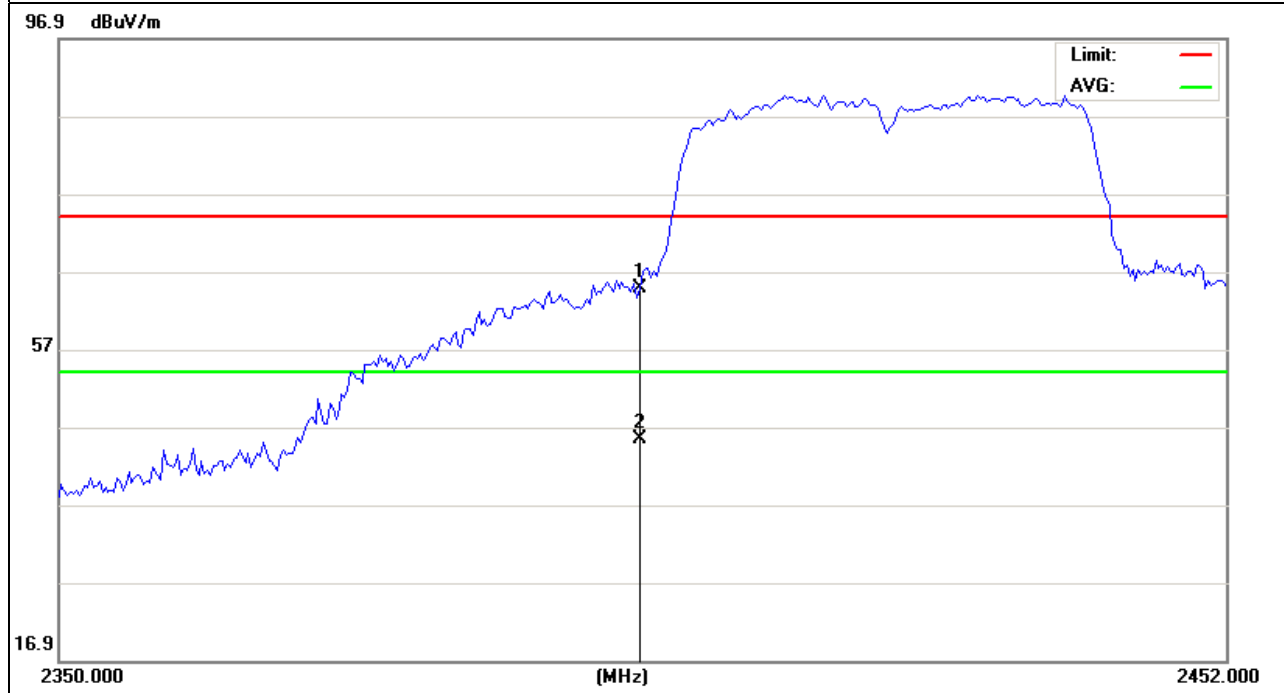

EUT :	IEEE 802.11b/g/n Long Range AP-Router	Model Name :	AIP-W525H
Temperature :	20 °C	Relative Humidity :	48%
Pressure :	1010 hPa	Test Voltage :	DC 12V
Test Mode :	CH9(802.11n Mode)/40MHz (A+B)Antenna	Polarization :	Horizontal

Frequency (MHz)	Meter Reading (dBµV)	Factor (dB)	Emission Level (dBµV/m)	Limits (dBµV/m)	Margin (dB)	Detector Type
2483.5	68.32	-0.47	67.85	74	-6.15	peak
2483.5	48.31	-0.47	47.84	54	-6.16	AVG

Remark:
Factor = Antenna Factor + Cable Loss – Pre-amplifier.

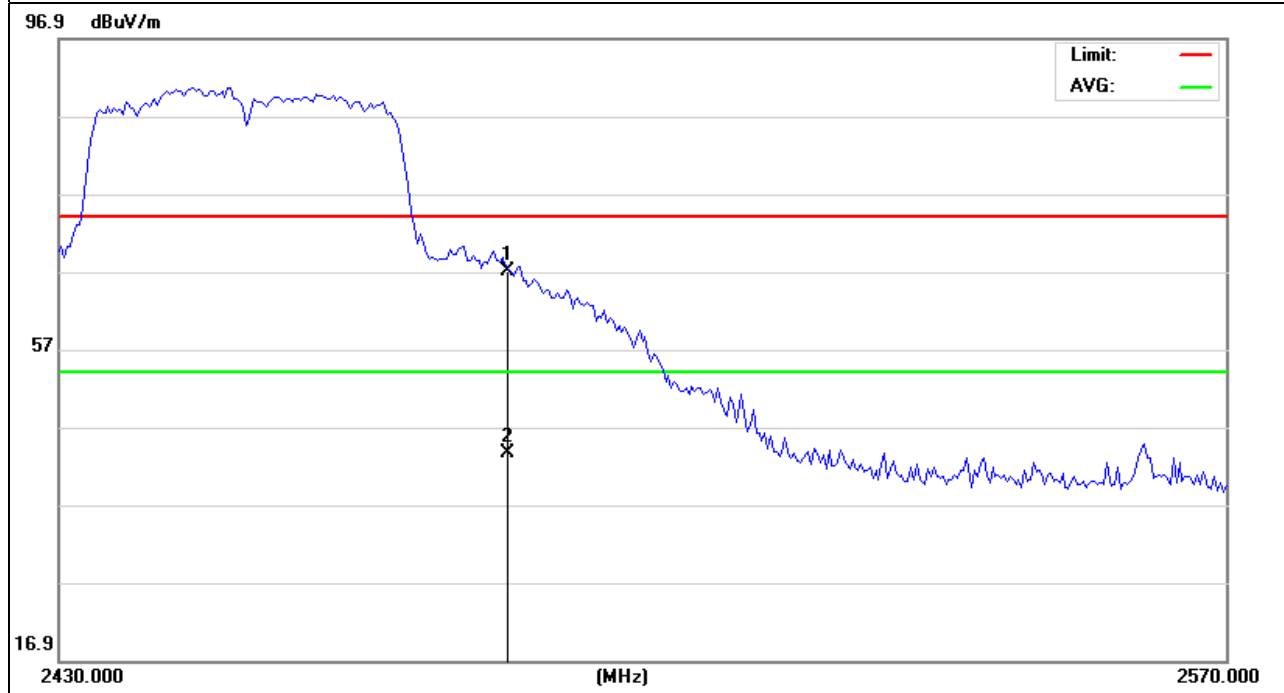

EUT :	IEEE 802.11b/g/n Long Range AP-Router	Model Name :	AIP-W525H
Temperature :	20 °C	Relative Humidity :	48%
Pressure :	1010 hPa	Test Voltage :	DC 12V
Test Mode :	CH9(802.11n Mode)/40MHz (A+B)Antenna	Polarization :	Vertical

Frequency (MHz)	Meter Reading (dBμV)	Factor (dB)	Emission Level (dBμV/m)	Limits (dBμV/m)	Margin (dB)	Detector Type
2483.5	68.69	-0.47	68.22	74	-5.78	peak
2483.5	48.78	-0.47	48.31	54	-5.69	AVG

Remark:
 Factor = Antenna Factor + Cable Loss – Pre-amplifier.

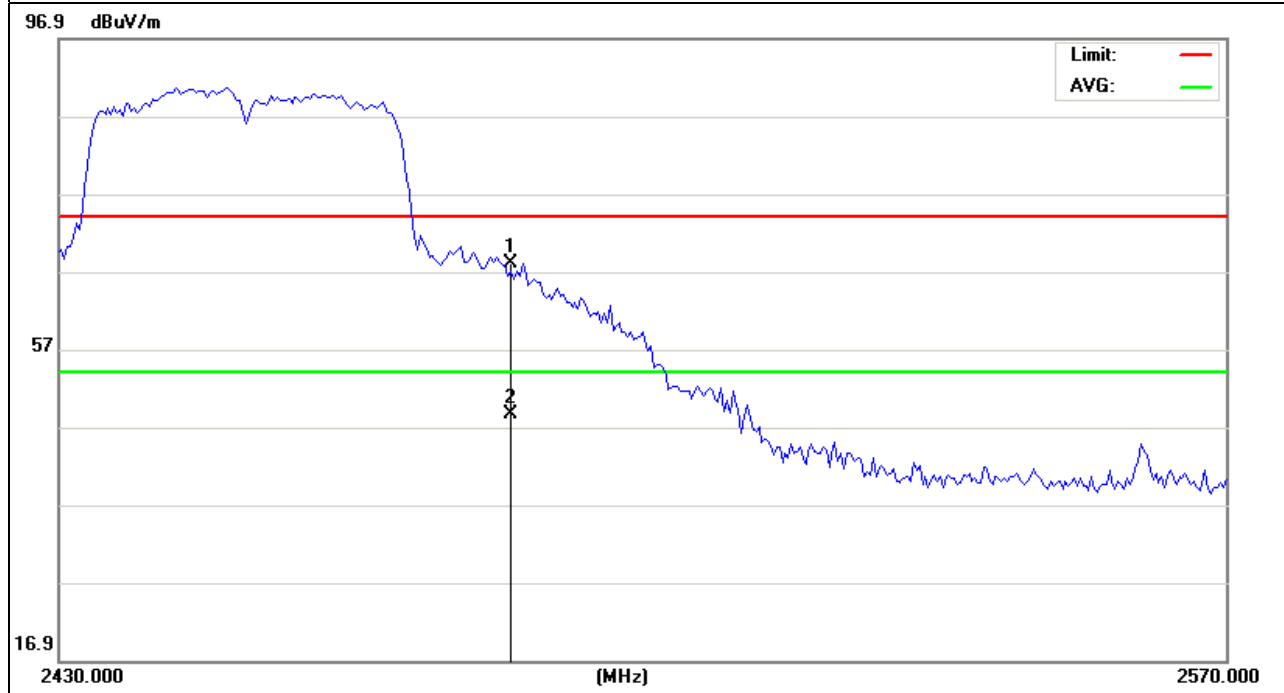

5. POWER SPECTRAL DENSITY TEST

5.1 APPLIED PROCEDURES / LIMIT

FCC Part15 (15.247) , Subpart C				
Section	Test Item	Limit	Frequency Range (MHz)	Result
15.247	Power Spectral Density	8 dBm (in any 3KHz)	2400-2483.5	PASS

Spectrum Parameters	Setting
Attenuation	Auto
Span Frequency	> Operating Frequency Range
RB	3 kHz
VB	30 kHz
Detector	Peak
Trace	Max Hold
Sweep Time	500s

5.1.1 TEST PROCEDURE

- a. The EUT was directly connected to the spectrum analyzer and antenna output port as show in the block diagram below,
- b. Spectrum Setting : RBW= 3KHz, VBW=30KHz, Sweep time = 500s.

5.1.2 DEVIATION FROM STANDARD

No deviation.

5.1.3 TEST SETUP



5.1.4 EUT OPERATION CONDITIONS

The EUT tested system was configured as the statements of 2.1 Unless otherwise a special operating condition is specified in the follows during the testing.

5.1.5 TEST RESULTS

EUT :	IEEE 802.11b/g/n Long Range AP-Router	Model Name :	AIP-W525H
Temperature :	25 °C	Relative Humidity :	60%
Pressure :	1015 hPa	Test Voltage :	DC 12V
Test Mode :	TX B MODE /CH01, CH06, CH11		

Frequency	Power Density A (dBm)	Power Density B (dBm)	Limit (dBm)	Result
2412 MHz	6.516	1.321	8	PASS
2437MHz	6.161	1.158	8	PASS
2462 MHz	5.936	1.669	8	PASS

Note: A(B) Represent the value of antenna A and B, The worst data is A Antenna , only shown Antenna A Plot.

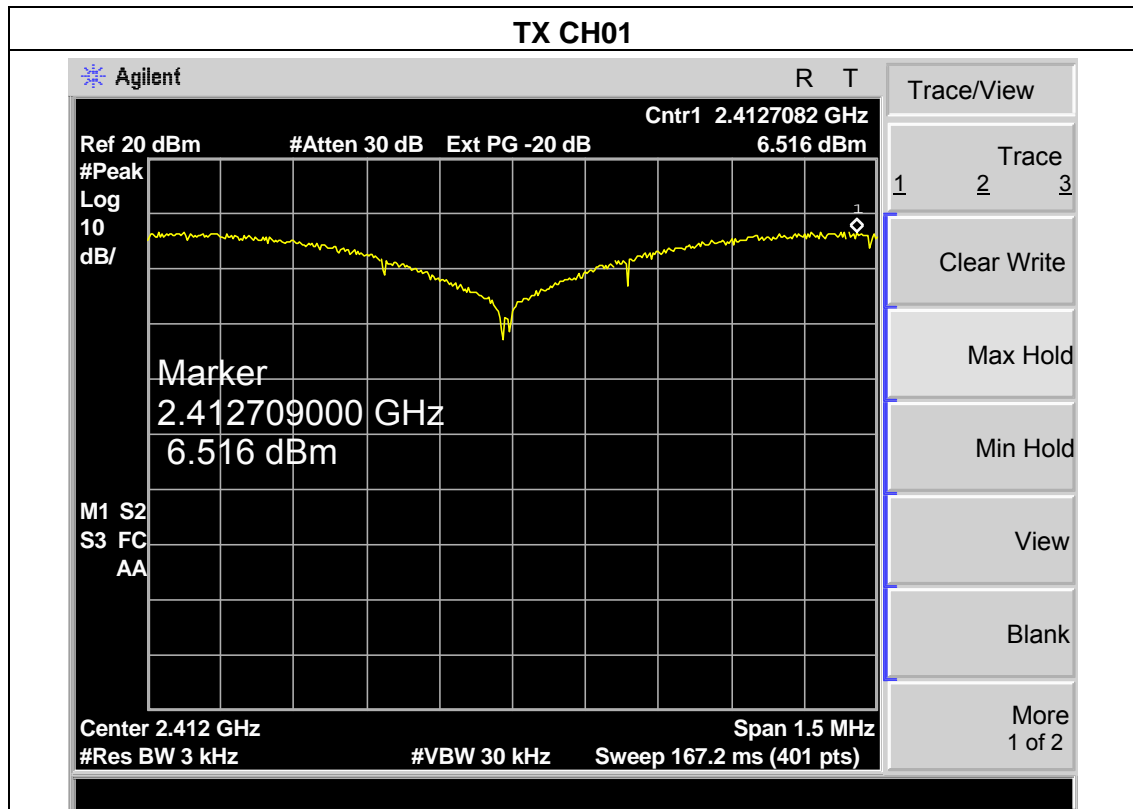

TX CH06

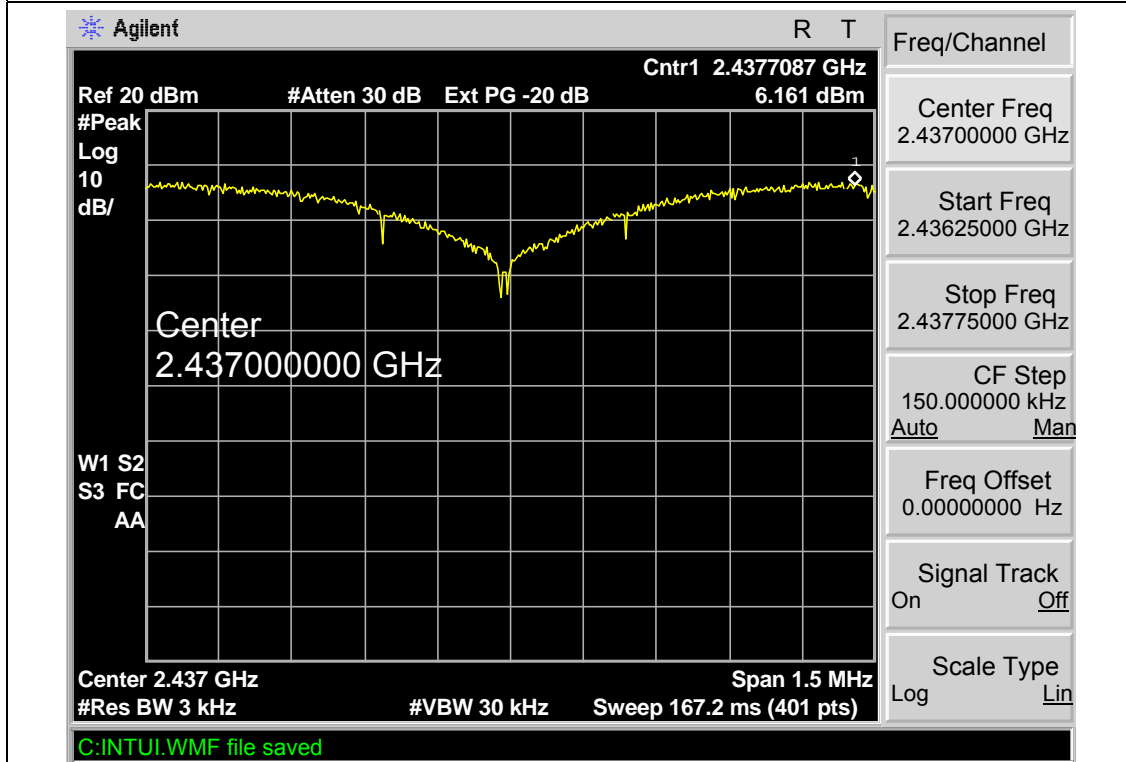

TX CH11

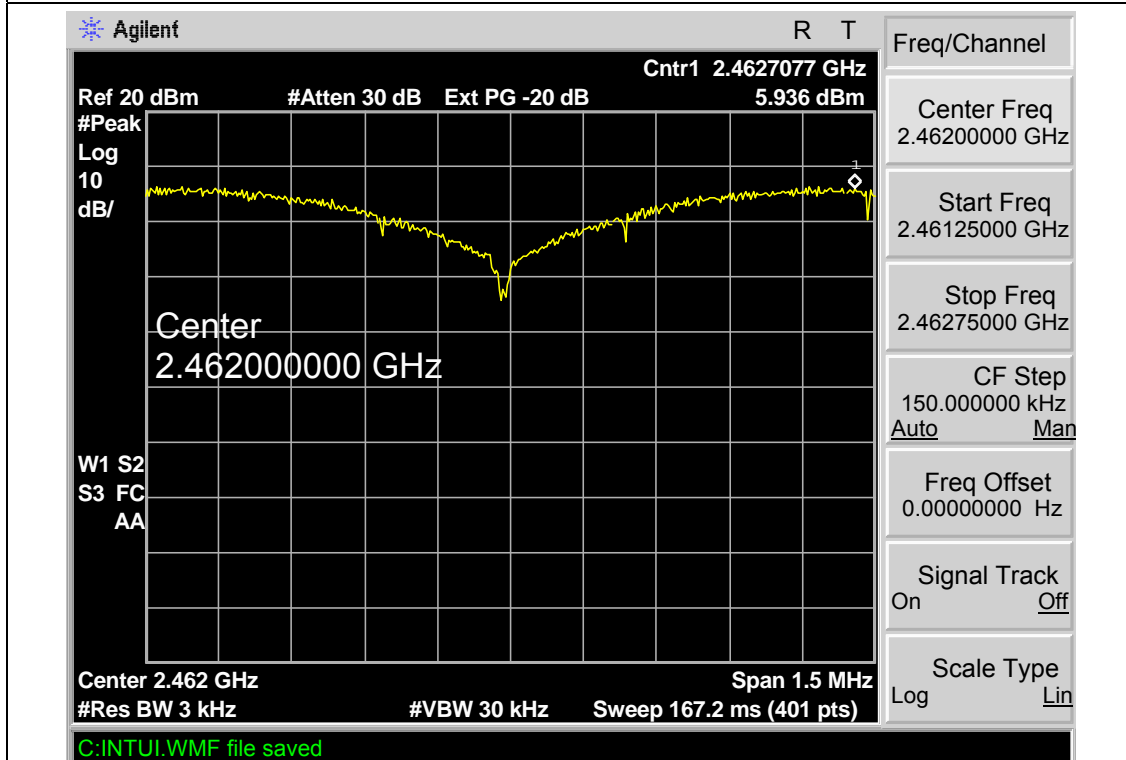

EUT :	IEEE 802.11b/g/n Long Range AP-Router	Model Name :	AIP-W525H
Temperature :	25 °C	Relative Humidity :	60%
Pressure :	1015 hPa	Test Voltage :	DC 12V
Test Mode :	TX G MODE /CH01, CH06, CH11		

Frequency	Power Density A (dBm)	Power Density B (dBm)	Limit (dBm)	Result
2412 MHz	5.182	1.226	8	PASS
2437MHz	5.346	1.687	8	PASS
2462 MHz	3.118	1.011	8	PASS

Note: A(B) Represent the value of antennaA and B,The worst data is A Antenna , only shown Antenna A Plot.

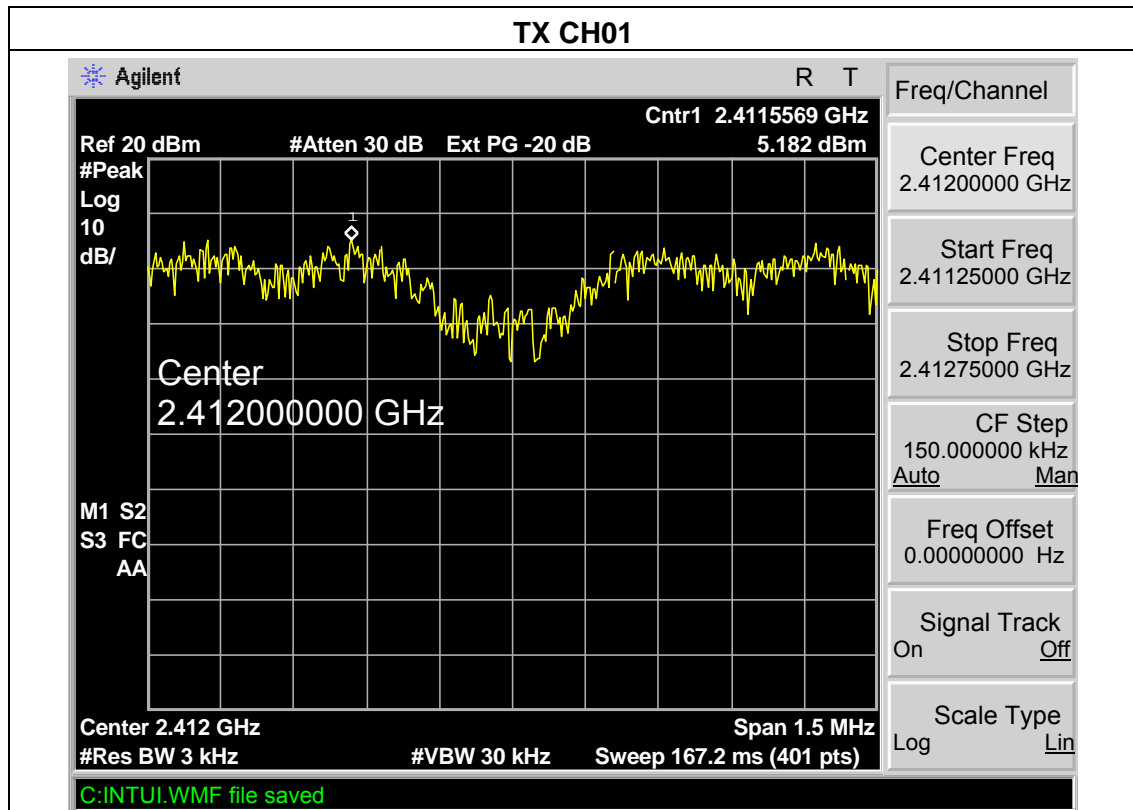

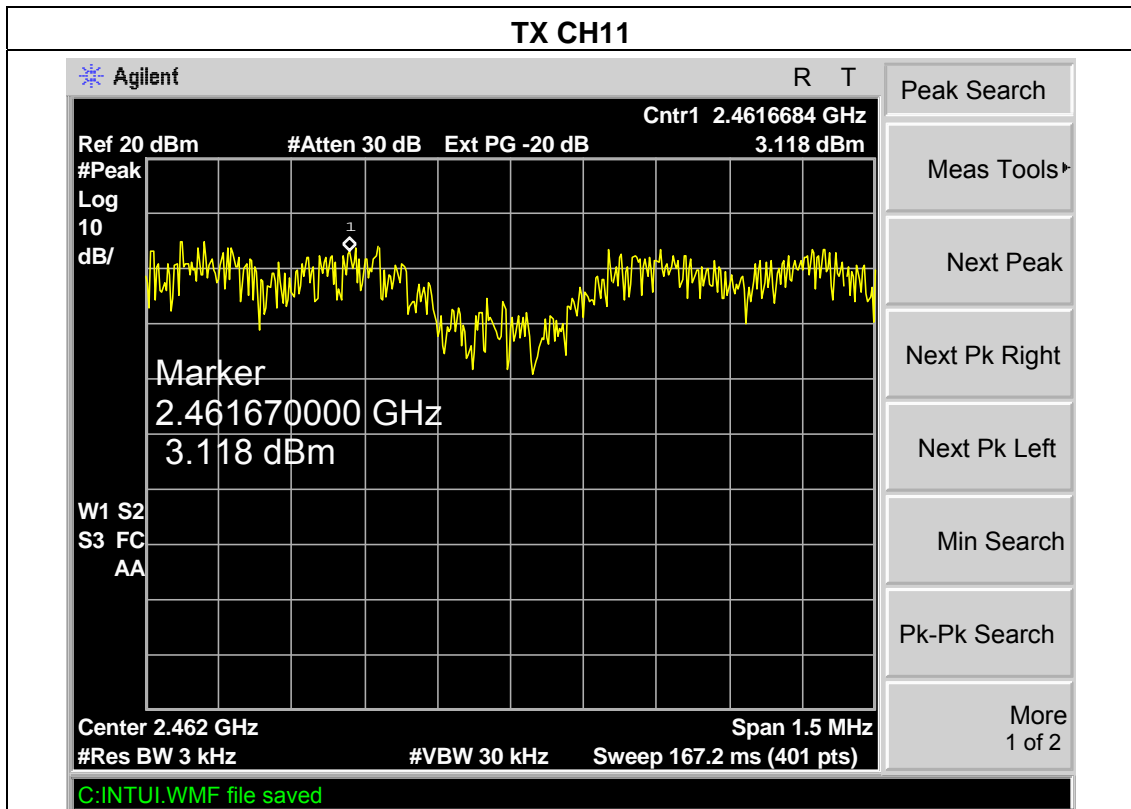
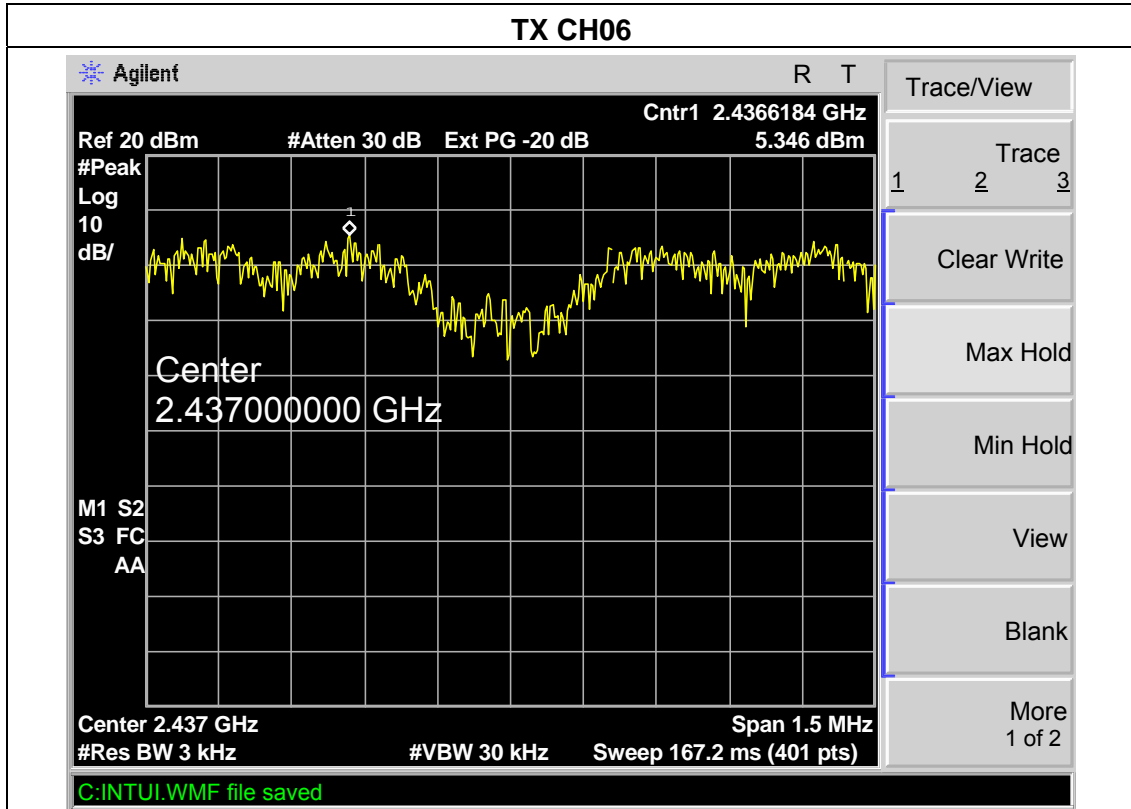

EUT :	IEEE 802.11b/g/n Long Range AP-Router	Model Name :	AIP-W525H
Temperature :	25 °C	Relative Humidity :	60%
Pressure :	1015 hPa	Test Voltage :	DC 12V
Test Mode :	TX n MODE /CH01, CH06, CH11		

Frequency	Power Density A (dBm)	Power Density B (dBm)	Total Power (dBm)	Limit (dBm)	Result
2412 MHz	3.118	1.154	4.59	8	PASS
2437MHz	3.302	1.264	4.65	8	PASS
2462 MHz	4.317	1.365	4.98	8	PASS

Note: A(B) Represent the value of antennaA and B,The worst data is A Antenna a ,only shown Antenna A Plot.

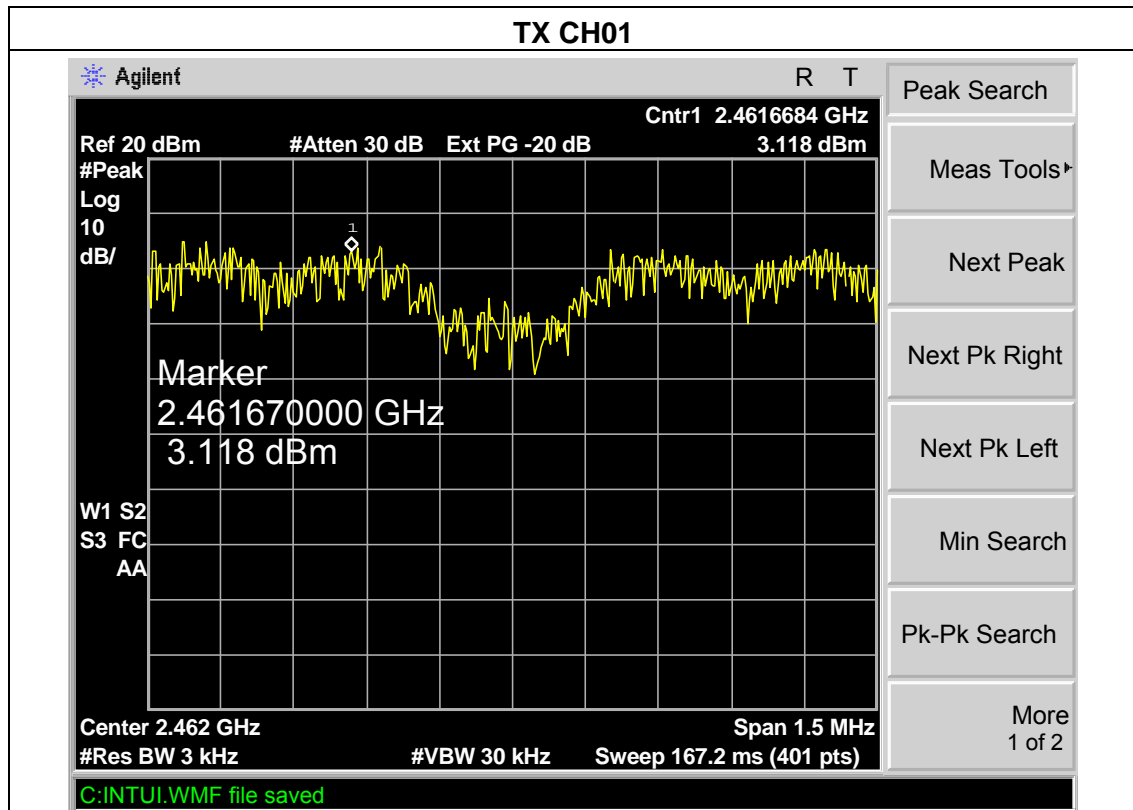

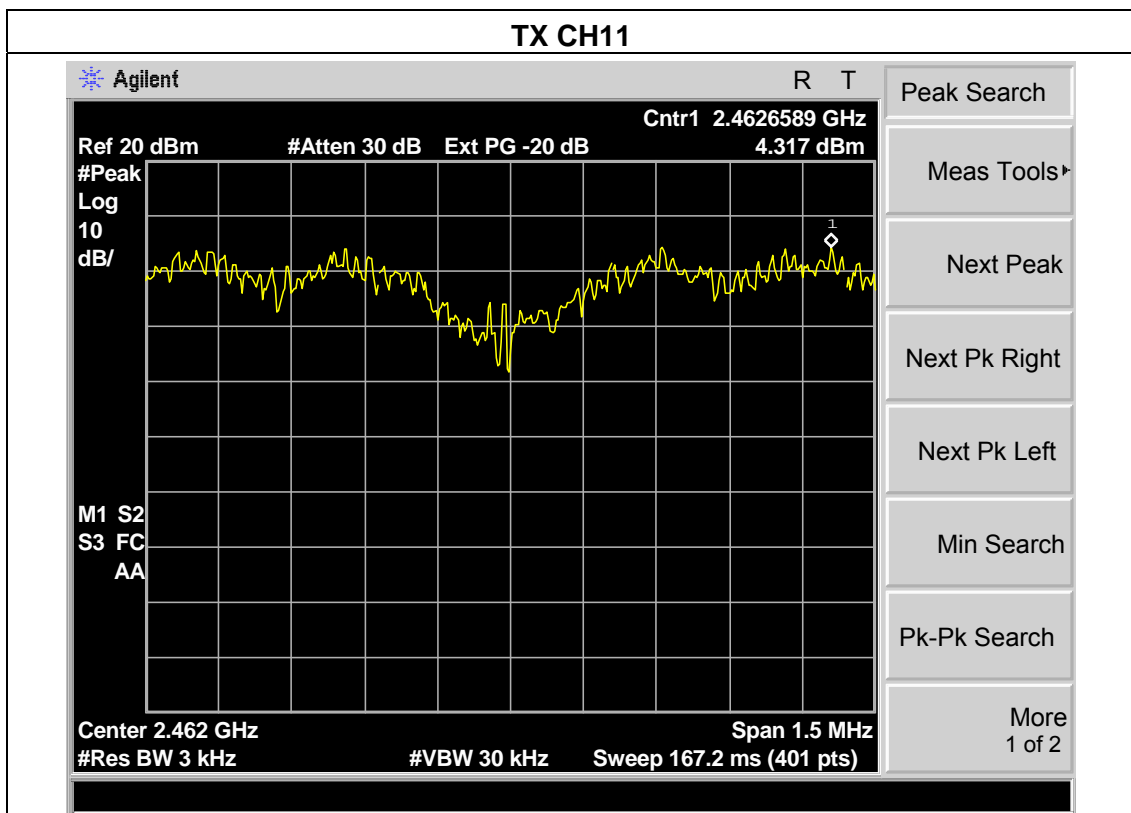
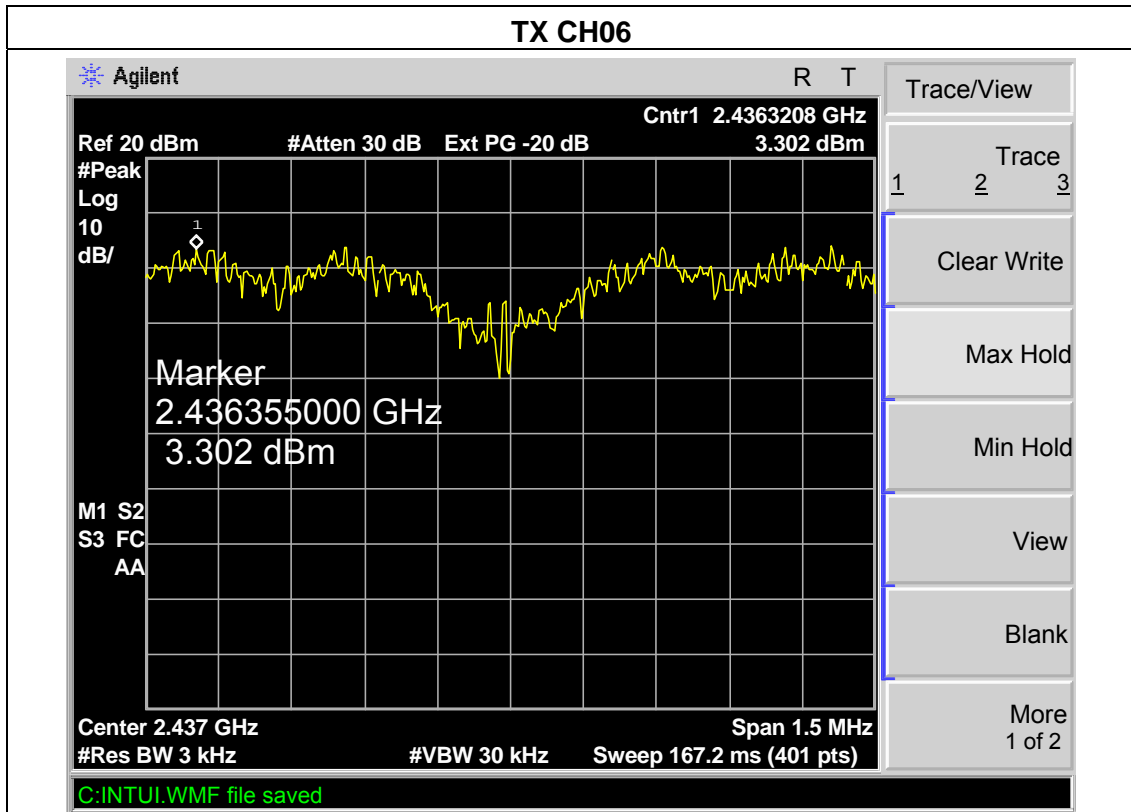

EUT :	IEEE 802.11b/g/n Long Range AP-Router	Model Name :	AIP-W525H
Temperature :	25 °C	Relative Humidity :	60%
Pressure :	1015 hPa	Test Voltage :	DC 12V
Test Mode :	TX n MODE /CH03, CH06, CH09/40MHz		

Frequency	Power Density A (dBm)	Power Density B (dBm)	Total Power (dBm)	Limit (dBm)	Result
2412 MHz	2.992	1.065	3.54	8	PASS
2437MHz	5.974	1.664	6.12	8	PASS
2462 MHz	3.805	1.007	4.15	8	PASS

Note: A(B) Represent the value of antenna A and B, The worst data is A Antenna , only shown Antenna A Plot.

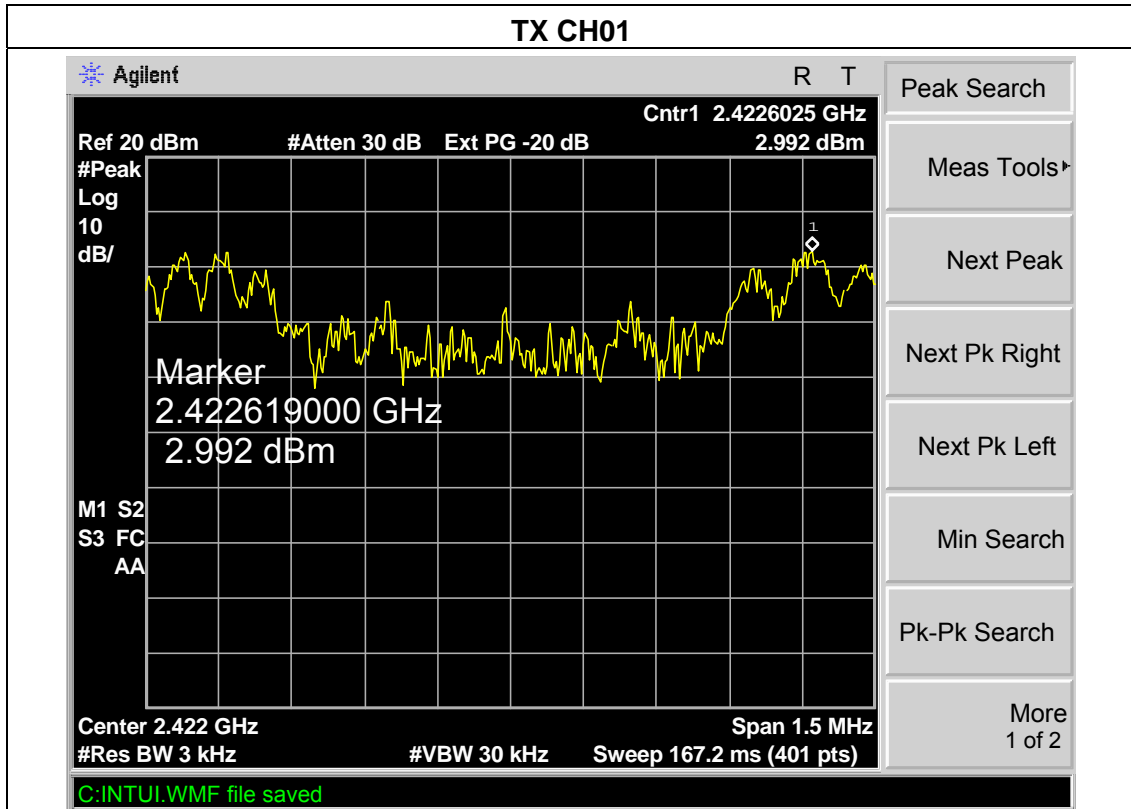

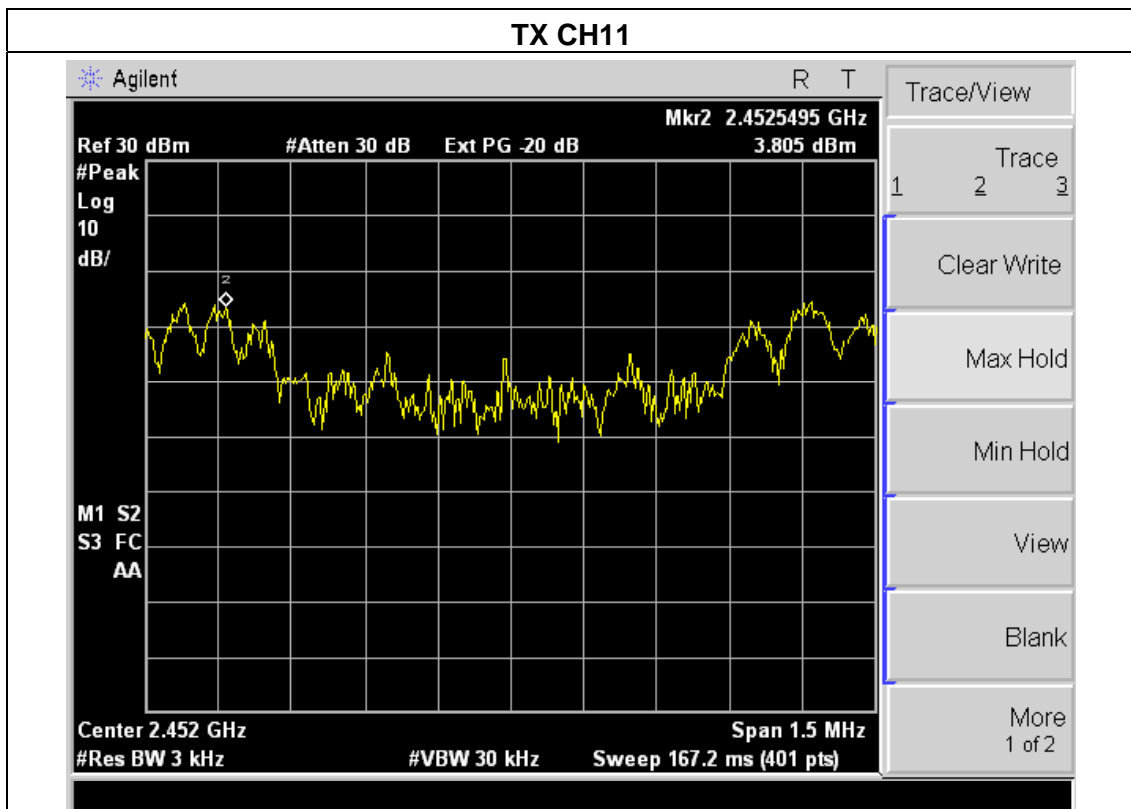
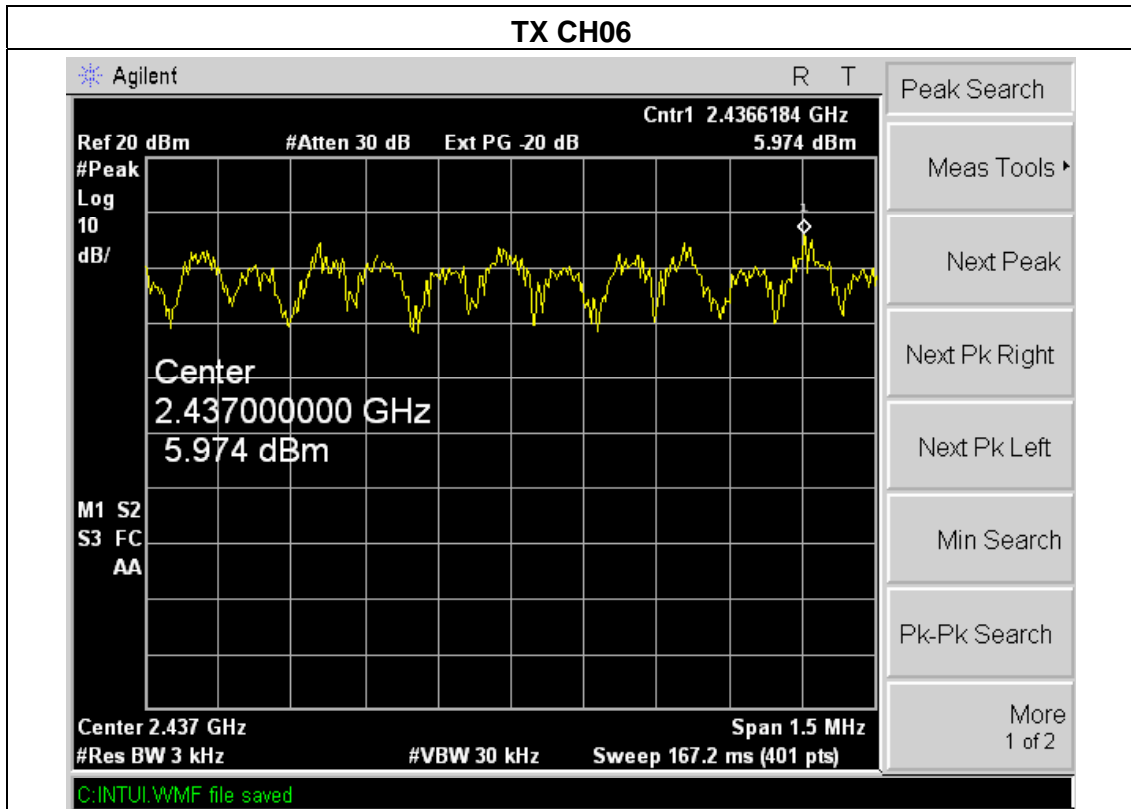

6. BANDWIDTH TEST

6.1 APPLIED PROCEDURES / LIMIT

FCC Part15 (15.247) , Subpart C				
Section	Test Item	Limit	Frequency Range (MHz)	Result
15.247(a)(2)	Bandwidth	$\geq 500\text{KHz}$ (6dB bandwidth)	2400-2483.5	PASS

Spectrum Parameter	Setting
Attenuation	Auto
Span Frequency	$>$ Measurement Bandwidth or Channel Separation
RB	30 kHz (20dB Bandwidth) / 100 kHz (Channel Separation)
VB	100 kHz (20dB Bandwidth) / 300 kHz (Channel Separation)
Detector	Peak
Trace	Max Hold
Sweep Time	Auto

6.1.1 TEST PROCEDURE

- a. The EUT was directly connected to the spectrum analyzer and antenna output port as show in the block diagram below,
- b. Spectrum Setting : RBW= 100KHz, VBW=100KHz, Sweep time = Auto.

6.1.2 DEVIATION FROM STANDARD

No deviation.

6.1.3 TEST SETUP

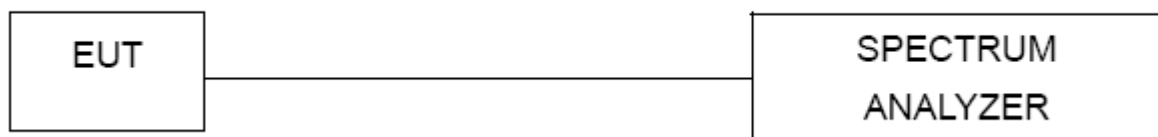

6.1.4 EUT OPERATION CONDITIONS

The EUT tested system was configured as the statements of 2.4 Unless otherwise a special operating condition is specified in the follows during the testing.

6.1.5 TEST RESULTS

EUT :	IEEE 802.11b/g/n Long Range AP-Router	Model Name :	AIP-W525H
Temperature :	25 °C	Relative Humidity :	60%
Pressure :	1012 hPa	Test Voltage :	DC 12V
Test Mode :	TX B MODE /CH01, CH06, CH11		

Frequency	6dB Bandwidth (MHz)	99% Occupied BW (MHz)	Channel Separation (MHz)	Result
2412 MHz	10.07	14.59	>=500KHz	PASS
2437 MHz	9.85	14.68	>=500KHz	PASS
2462 MHz	10.11	14.74	>=500KHz	PASS

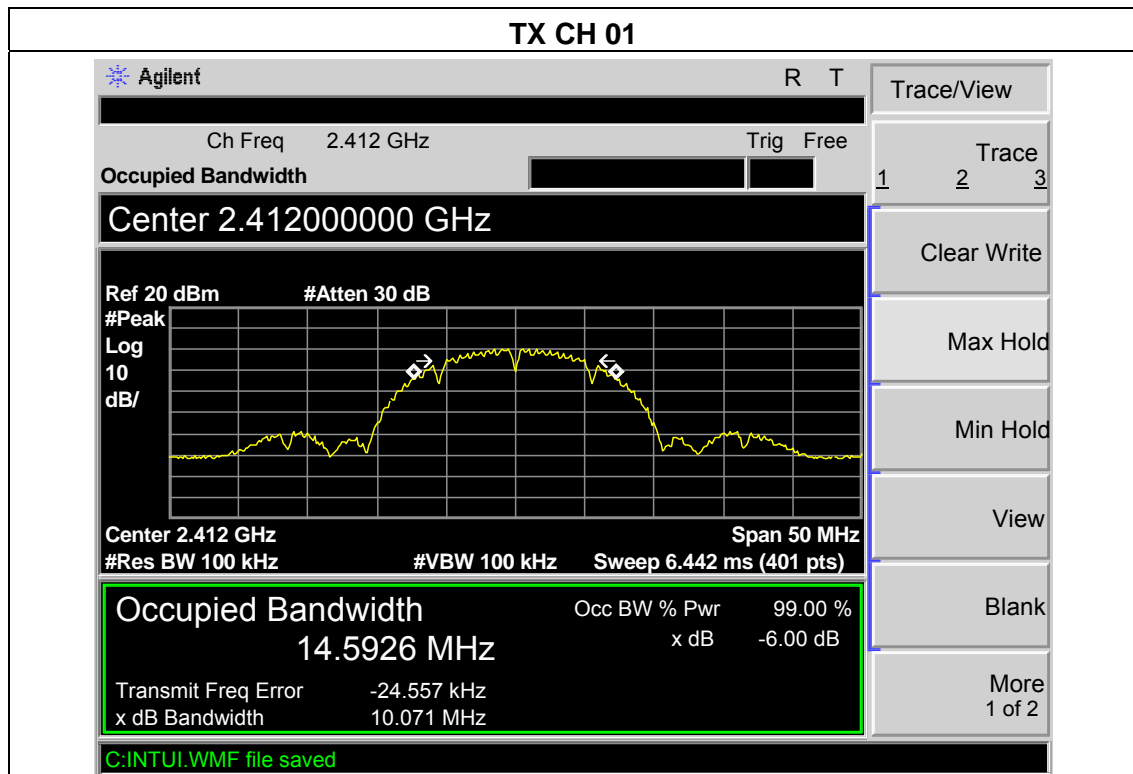

TX CH 06

Agilent
R T

Ch Freq 2.437 GHz Trig Free

Occupied Bandwidth
Trace/View

Center 2.43700000 GHz

Ref 20 dBm #Peak
#Atten 30 dB

Log 10 dB/

Center 2.437 GHz Span 50 MHz
 #Res BW 100 kHz #VBW 100 kHz Sweep 6.442 ms (401 pts)

Occupied Bandwidth	Occ BW % Pwr	99.00 %
14.6864 MHz	x dB	-6.00 dB
Transmit Freq Error	-32.155 kHz	
x dB Bandwidth	9.859 MHz	

C:INTUI.WMF file saved

TX CH 11

Agilent
R T

Ch Freq 2.462 GHz Trig Free

Occupied Bandwidth
Freq/Channel

Center 2.46200000 GHz

Ref 20 dBm #Peak
#Atten 30 dB

Log 10 dB/

Center 2.462 GHz Span 50 MHz
 #Res BW 100 kHz #VBW 100 kHz Sweep 6.442 ms (401 pts)

Occupied Bandwidth	Occ BW % Pwr	99.00 %
14.7417 MHz	x dB	-6.00 dB
Transmit Freq Error	-52.996 kHz	
x dB Bandwidth	10.117 MHz	

C:INTUI.WMF file saved

EUT :	IEEE 802.11b/g/n Long Range AP-Router	Model Name :	AIP-W525H
Temperature :	25 °C	Relative Humidity :	60%
Pressure :	1012 hPa	Test Voltage :	DC 12V
Test Mode :	TX G MODE /CH01, CH06, CH11		

Frequency	6dB Bandwidth (MHz)	99% Occupied BW (MHz)	Channel Separation (MHz)	Result
2412 MHz	16.59	16.47	>=500KHz	PASS
2437 MHz	16.66	16.52	>=500KHz	PASS
2462 MHz	16.65	16.51	>=500KHz	PASS

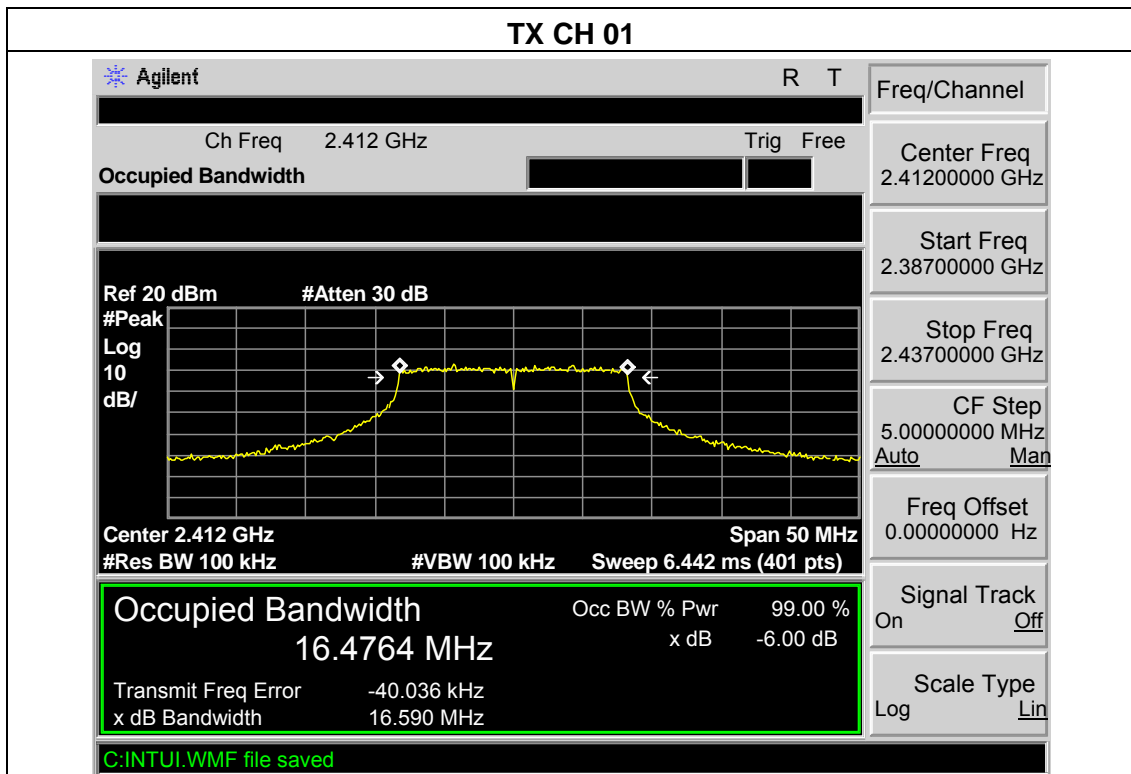

TX CH 06

Agilent
R T

Ch Freq 2.437 GHz
Trig Free

Occupied Bandwidth

Ref Level 20.00 dBm

Ref 20 dBm
#Atten 30 dB

#Peak

Log

10

dB/



Center 2.437 GHz

#Res BW 100 kHz

#VBW 100 kHz

Sweep 6.442 ms (401 pts)

Span 50 MHz

Occupied Bandwidth
16.5208 MHz

Occ BW % Pwr 99.00 %

x dB -6.00 dB

Transmit Freq Error -25.721 kHz

x dB Bandwidth 16.662 MHz

Amplitude

Y Axis Units dBm

Ref Lvl Offst 0.00 dB

Int Preamp On Off

Corrections

Ext Amp Gain 0.00 dB

Max Mixer Lvl -10.00 dBm

More 2 of 3

TX CH 11

Agilent
R T

Ch Freq 2.462 GHz
Trig Free

Occupied Bandwidth

Ref Level 20.00 dBm

Ref 20 dBm
#Atten 30 dB

#Peak

Log

10

dB/

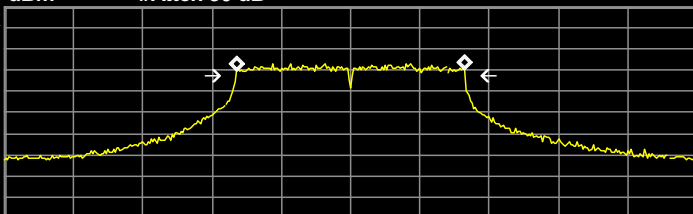

Center 2.462 GHz

#Res BW 100 kHz

#VBW 100 kHz

Sweep 6.442 ms (401 pts)

Span 50 MHz

Occupied Bandwidth
16.5163 MHz

Occ BW % Pwr 99.00 %

x dB -6.00 dB

Transmit Freq Error -20.195 kHz

x dB Bandwidth 16.658 MHz

Trace/View

Trace 1 2 3

Clear Write

Max Hold

Min Hold

View

Blank

More 1 of 2

C:\INTUI.WMF file saved

EUT :	IEEE 802.11b/g/n Long Range AP-Router	Model Name :	AIP-W525H
Temperature :	25 °C	Relative Humidity :	60%
Pressure :	1012 hPa	Test Voltage :	DC 12V
Test Mode :	TX n MODE /CH01, CH06, CH11/20MHz		

Frequency	6dB Bandwidth (MHz)	99% Occupied BW (MHz)	Channel Separation (MHz)	Result
2412 MHz	17.83	17.68	>=500KHz	PASS
2437 MHz	17.86	17.69	>=500KHz	PASS
2462 MHz	17.87	17.70	>=500KHz	PASS

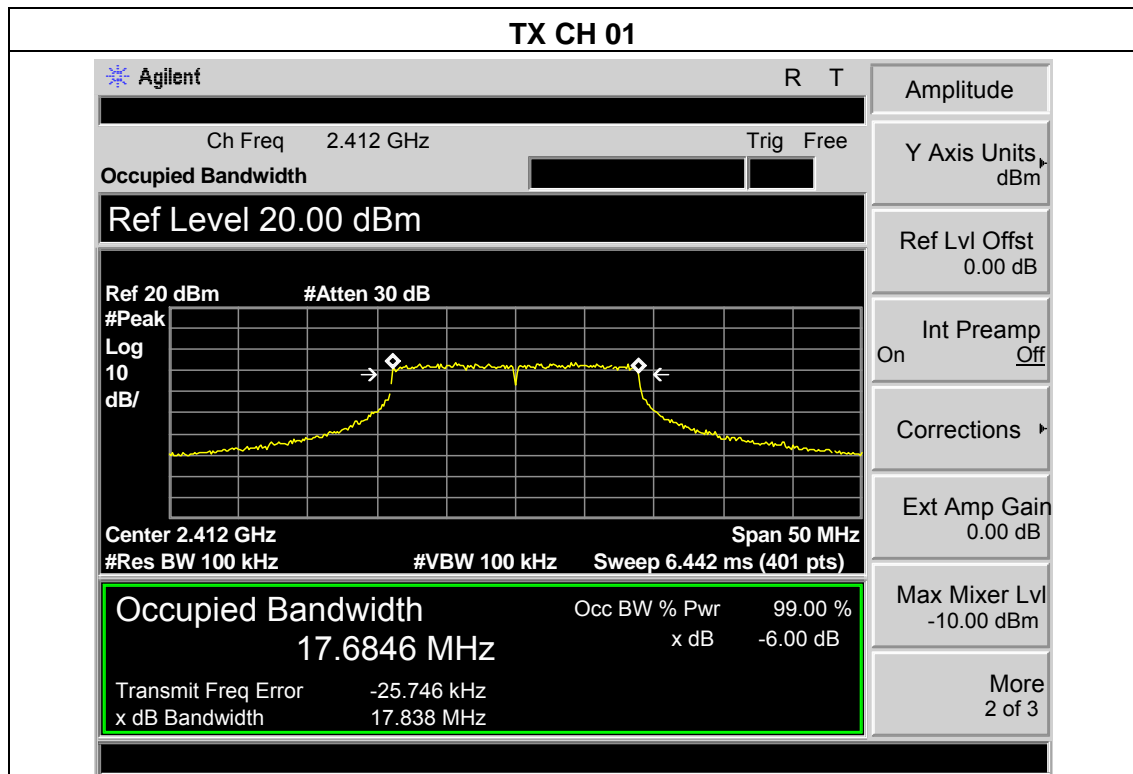

TX CH 06

Agilent R T

Ch Freq 2.437 GHz Trig Free

Occupied Bandwidth [Bar]

Center 2.43700000 GHz

Ref 20 dBm #Atten 30 dB

#Peak

Log 10 dB/



Center 2.437 GHz Span 50 MHz

#Res BW 100 kHz #VBW 100 kHz Sweep 6.442 ms (401 pts)

Occupied Bandwidth

17.6934 MHz

Transmit Freq Error -27.366 kHz

x dB Bandwidth 17.857 MHz

C:INTUI.WMF file saved

Freq/Channel

Center Freq 2.43700000 GHz

Start Freq 2.41200000 GHz

Stop Freq 2.46200000 GHz

CF Step 5.00000000 MHz
Auto Man

Freq Offset 0.00000000 Hz

Signal Track On Off

Scale Type Log Lin

TX CH 11

Agilent R T

Ch Freq 2.462 GHz Trig Free

Occupied Bandwidth [Bar]

Ref 20 dBm #Atten 30 dB

#Peak

Log 10 dB/

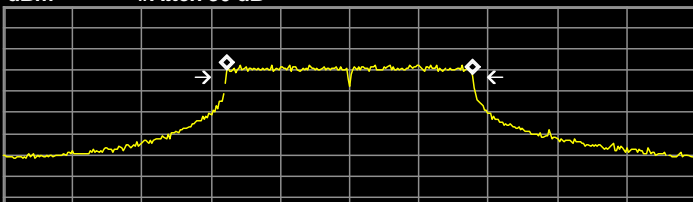

Center 2.462 GHz Span 50 MHz

#Res BW 100 kHz #VBW 100 kHz Sweep 6.442 ms (401 pts)

Occupied Bandwidth

17.7051 MHz

Transmit Freq Error -22.977 kHz

x dB Bandwidth 17.877 MHz

C:INTUI.WMF file saved

Trace/View

Trace 1 2 3

Clear Write

Max Hold

Min Hold

View

Blank

More 1 of 2

EUT :	IEEE 802.11b/g/n Long Range AP-Router	Model Name :	AIP-W525H
Temperature :	25 °C	Relative Humidity :	60%
Pressure :	1012 hPa	Test Voltage :	DC 12V
Test Mode :	TX n MODE /CH03, CH06, CH09/40MHz		

Frequency	6dB Bandwidth (MHz)	99% Occupied BW (MHz)	Channel Separation (MHz)	Result
2412 MHz	36.53	36.02	>=500KHz	PASS
2437 MHz	36.53	35.98	>=500KHz	PASS
2462 MHz	36.54	35.99	>=500KHz	PASS

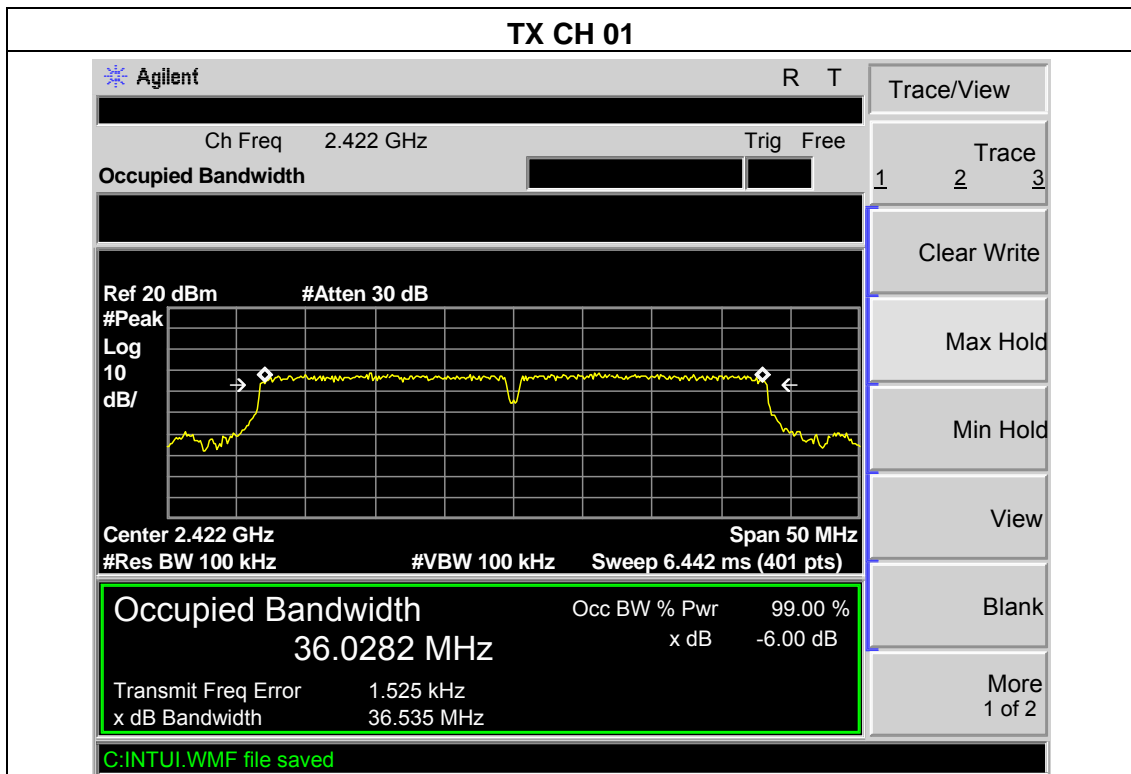

TX CH 06

Agilent R T

Ch Freq 2.437 GHz Trig Free

Occupied Bandwidth [Bar]

Ref 20 dBm #Atten 30 dB

#Peak

Log 10 dB/

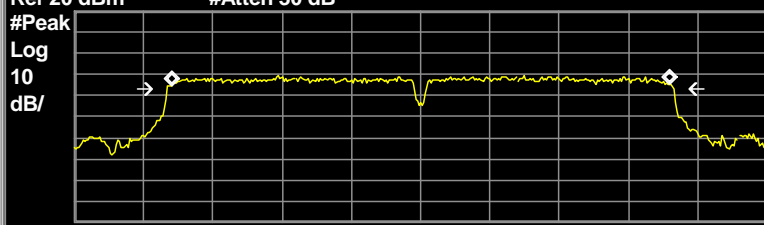

Center 2.437 GHz Span 50 MHz

#Res BW 100 kHz #VBW 100 kHz Sweep 6.442 ms (401 pts)

Occupied Bandwidth Occ BW % Pwr 99.00 %

35.9824 MHz x dB -6.00 dB

Transmit Freq Error -2.338 kHz

x dB Bandwidth 36.535 MHz

C:INTUI.WMF file saved

Freq/Channel

Center Freq 2.43700000 GHz

Start Freq 2.41200000 GHz

Stop Freq 2.46200000 GHz

CF Step 5.00000000 MHz
Auto Man

Freq Offset 0.00000000 Hz

Signal Track On Off

Scale Type Log Lin

TX CH 11

Agilent R T

Ch Freq 2.452 GHz Trig Free

Occupied Bandwidth [Bar]

Center 2.45200000 GHz

Ref 20 dBm #Atten 30 dB

#Peak

Log 10 dB/

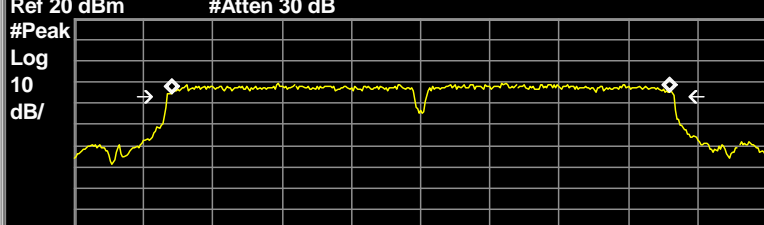

Center 2.452 GHz Span 50 MHz

#Res BW 100 kHz #VBW 100 kHz Sweep 6.442 ms (401 pts)

Occupied Bandwidth Occ BW % Pwr 99.00 %

35.9930 MHz x dB -6.00 dB

Transmit Freq Error 8.028 kHz

x dB Bandwidth 36.547 MHz

C:INTUI.WMF file saved

Trace/View

Trace 1 2 3

Clear Write

Max Hold

Min Hold

View

Blank

More 1 of 2

7. PEAK OUTPUT POWER TEST

7.1 APPLIED PROCEDURES / LIMIT

FCC Part15 (15.247) , Subpart C				
Section	Test Item	Limit	Frequency Range (MHz)	Result
15.247(b)(1)	Peak Output Power	1 watt or 30dBm	2400-2483.5	PASS

7.1.1 TEST PROCEDURE

- a. The EUT was directly connected to the spectrum analyzer.

7.1.2 DEVIATION FROM STANDARD

No deviation.

7.1.3 TEST SETUP



7.1.4 EUT OPERATION CONDITIONS

The EUT tested system was configured as the statements of 2.4 Unless otherwise a special operating condition is specified in the follows during the testing.

7.1.5 TEST RESULTS

EUT :	IEEE 802.11b/g/n Long Range AP-Router	Model Name :	AIP-W525H
Temperature :	25 °C	Relative Humidity :	60%
Pressure :	1012 hPa	Test Voltage :	DC 12V
Test Mode :	TX B MODE /CH01, CH06, CH11		

Test Channel	Frequency (MHz)	Peak output power. Antenna A (dBm)	Peak output power. Antenna B (dBm)	Antenna Gain A(B) (dBi)	Max. Power (dBm)	LIMIT (dBm)
CH01	2412	23.47	19.87	-1	22.47	30
CH06	2437	23.18	18.66	-1	22.18	30
CH11	2462	24.01	18.67	-1	23.01	30

Note: A(B) Represent the value of antennaA and B

Max Peak power plot.(A)

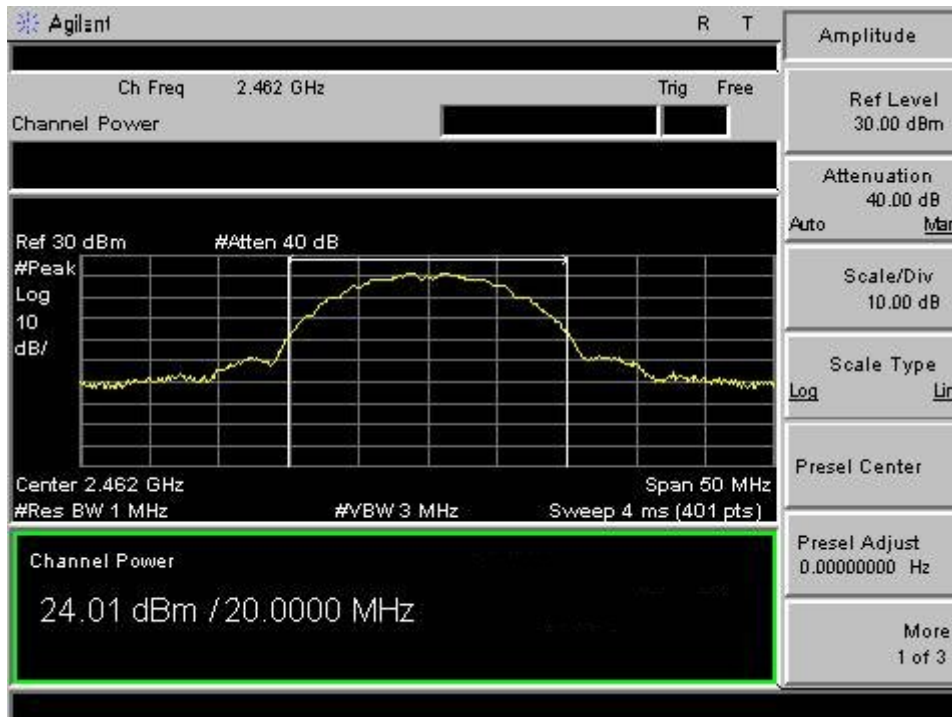

EUT :	IEEE 802.11b/g/n Long Range AP-Router	Model Name :	AIP-W525H			
Temperature :	25 °C	Relative Humidity :	60%			
Pressure :	1012 hPa	Test Voltage :	DC 12V			
Test Mode :	TX G MODE /CH01, CH06, CH11/20MHz					
Test Channel	Frequency (MHz)	Peak output power. Antenna A (dBm)	Peak output power. Antenna B (dBi)	Antenna Gain A(B) (dBi)	Max. Power (dBm)	LIMIT (dBm)
CH01	2412	26.98	18.64	-1	25.98	30
CH06	2437	27.17	18.66	-1	26.17	30
CH11	2462	26.45	18.24	-1	25.45	30

Note: A(B) Represent the value of antennaA and B

Max Peak power plot.(A)

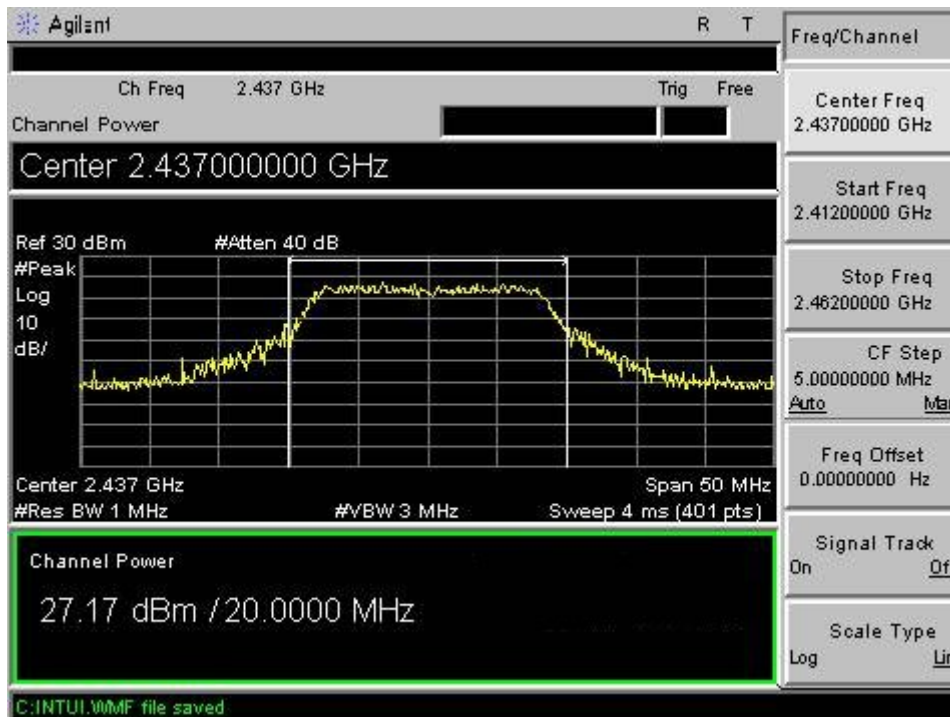

EUT :	IEEE 802.11b/g/n Long Range AP-Router	Model Name :	AIP-W525H
Temperature :	25 °C	Relative Humidity :	60%
Pressure :	1012 hPa	Test Voltage :	DC 12V
Test Mode :	TX N MODE /CH01, CH06, CH11		

Test Channel	Frequency (MHz)	Peak output power. Antenna A(B) (dBm)	Antenna Gain A(B) dBi	EIRP A(B) dBm	Total Power dBm	LIMIT dBm
CH01	2412	27.22(18.12)	-1	26.22(17.12)	26.7239	30
CH06	2437	27.15(18.42)	-1	26.15(17.42)	26.7578	30
CH11	2462	27.35(18.33)	-1	26.35(17.33)	26.86274	30

Note: A(B) Represent the value of antennaA and B

Max Peak power plot.(A)



8. EUT TEST PHOTO

Radiated Measurement Photos

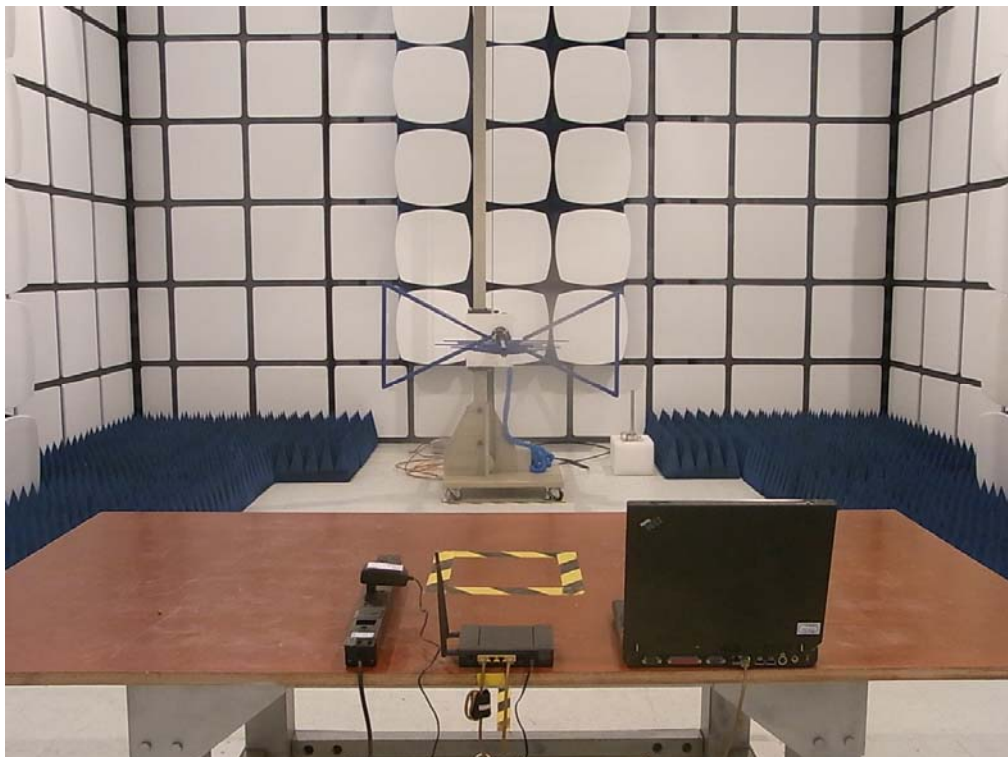
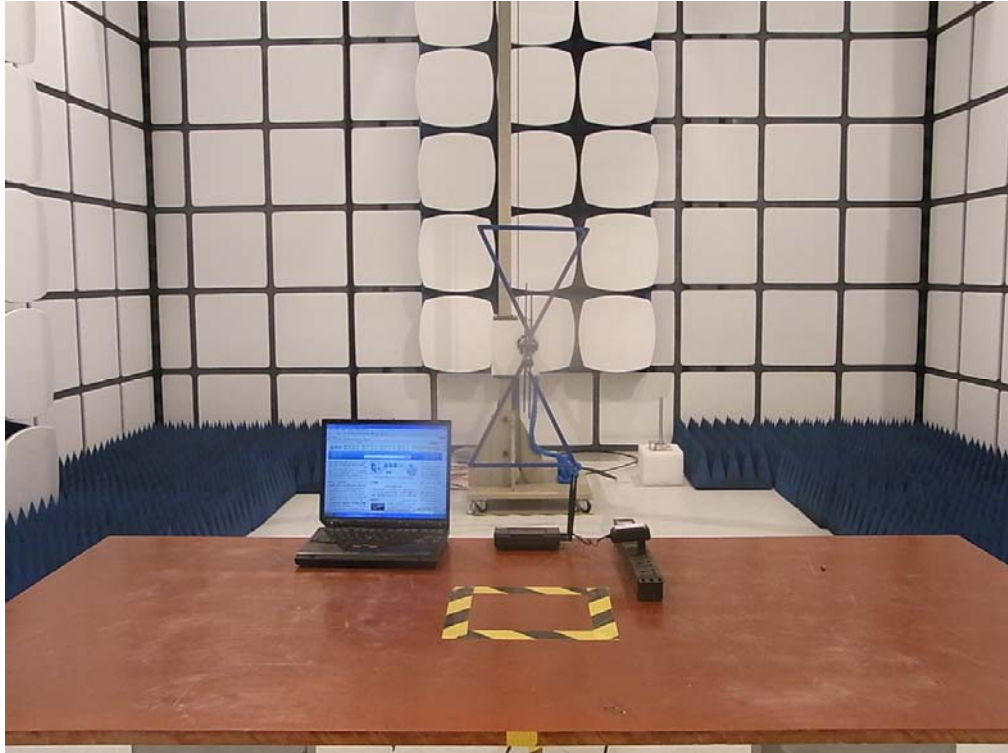

Conducted Measurement Photos

