

## RADIO TEST REPORT

Report Reference No. : POCE11091951RF

Compiled by (+ signature) ..... Jummy Qiu

*Jummy Qiu*

Approved by (+ signature) ..... Ada Li

*Ada Li*

Date of issue .....: 2011-09-26

Total number of pages ..... 77

**Applicant's name** .....: ALFA NETWORK Inc.

Address .....: 4F-1 No.106, Rueiguang Rd., Neihu Distric, Taipei City 114

**Manufacture's Name** .....: ALFA NETWORK Inc.

Address .....: 4F-1 No.106, Rueiguang Rd., Neihu Distric, Taipei City 114

**Factory's Name** .....: ALFA NETWORK Inc.

Address .....: 4F-1 No.106, Rueiguang Rd., Neihu Distric, Taipei City 114

**Test specification:**

Standard .....: FCC Part 15.247

Test procedure .....: ANSI C63.4 : 2003

Non-standard test method .....: N/A

**Test item description**

Product name ..... : IEEE 802.11b/g/n Long-Range USB Adapter

Trademark ..... : /

Model and/or type reference : AWUS036NHR, UBDo-nr, UBDo-ntr, UBDo-nr8

Rating(s) ..... : DC 5V by USB

**Possible test case verdicts:**

- test case does not apply to the test object N/A  
..... :
- test object does meet the requirement. : P (Pass)
- test object does not meet the requirement..... : F (Fail)

**Testing..... :**

Date of receipt of test item ..... : 2011-09-19  
Date (s) of performance of tests..... : 2011-09-21~2011-09-24

**General remarks:**

**The test results presented in this report relate only to the object tested.**

**The results contained in this report reflect the results for this particular model and serial number. It is the responsibility of the manufacturer to ensure that all production models meet the intent of the requirements detailed within this report.**

**This report would be invalid test report without all the signatures of testing technician and approver.**

**This report shall not be reproduced, except in full, without the written approval of the Issuing testing laboratory.**

**Table of Contents**

	<b>Page</b>
<b>1 . SUMMARY OF TEST RESULTS</b>	<b>5</b>
1.1 TEST FACILITY	6
1.2 MEASUREMENT UNCERTAINTY	6
<b>2 . GENERAL INFORMATION</b>	<b>7</b>
2.1 GENERAL DESCRIPTION OF EUT	7
2.2 DESCRIPTION OF TEST MODES	9
2.3 TABLE OF PARAMETERS OF TEXT SOFTWARE SETTING	9
2.4 BLOCK DIGRAM SHOWING THE CONFIGURATION OF SYSTEM TESTED	10
2.5 DESCRIPTION OF SUPPORT UNITS(CONDUCTED MODE)	11
2.6 EQUIPMENTS LIST FOR ALL TEST ITEMS	12
<b>3 . EMC EMISSION TEST</b>	<b>13</b>
3.1 CONDUCTED EMISSION MEASUREMENT	13
3.1.1 POWER LINE CONDUCTED EMISSION LIMITS	13
3.1.2 TEST PROCEDURE	14
3.1.3 DEVIATION FROM TEST STANDARD	14
3.1.4 TEST SETUP	14
3.1.5 EUT OPERATING CONDITIONS	15
3.1.6 TEST RESULTS	16
3.2 RADIATED EMISSION MEASUREMENT	18
3.2.1 RADIATED EMISSION LIMITS	18
3.2.2 TEST PROCEDURE	19
3.2.3 DEVIATION FROM TEST STANDARD	19
3.2.4 TEST SETUP	20
3.2.5 EUT OPERATING CONDITIONS	20
3.2.6 TEST RESULTS (BETWEEN 9KHZ – 1000 MHZ)	21
3.2.7 TEST RESULTS (ABOVE 1000 MHZ)	23
<b>4 . POWER SPECTRAL DENSITY TEST</b>	<b>47</b>
4.1 APPLIED PROCEDURES / LIMIT	47
4.1.1 TEST PROCEDURE	47
4.1.2 DEVIATION FROM STANDARD	47
4.1.3 TEST SETUP	47
4.1.4 EUT OPERATION CONDITIONS	47
4.1.5 TEST RESULTS	48
<b>5 . BANDWIDTH TEST</b>	<b>56</b>
5.1 APPLIED PROCEDURES / LIMIT	56
5.1.1 TEST PROCEDURE	56

**Table of Contents**

	<b>Page</b>
5.1.2 DEVIATION FROM STANDARD	56
5.1.3 TEST SETUP	56
5.1.4 EUT OPERATION CONDITIONS	56
5.1.5 TEST RESULTS	57
<b>6 . PEAK OUTPUT POWER TEST</b>	<b>65</b>
6.1 APPLIED PROCEDURES / LIMIT	65
6.1.1 TEST PROCEDURE	65
6.1.2 DEVIATION FROM STANDARD	65
6.1.3 TEST SETUP	65
6.1.4 EUT OPERATION CONDITIONS	65
6.1.5 TEST RESULTS	66
<b>7 . ANTENNA CONDUCTED SPURIOUS EMISSION</b>	<b>68</b>
7.1 APPLIED PROCEDURES / LIMIT	68
7.1.1 TEST PROCEDURE	68
7.1.2 DEVIATION FROM STANDARD	68
7.1.3 TEST SETUP	69
7.1.4 EUT OPERATION CONDITIONS	69
7.1.5 TEST RESULTS	70
<b>8 . EUT TEST PHOTO</b>	<b>78</b>

## 1. SUMMARY OF TEST RESULTS

Test procedures according to the technical standards:

<b>FCC Part15 (15.247) , Subpart C</b>			
Standard Section	Test Item	Judgment	Remark
15.207	Conducted Emission	PASS	
15.247 (c)	Antenna conducted Spurious Emission	PASS	
15.247 (a)(2)	6dB Bandwidth	PASS	
15.247 (b)	Peak Output Power	PASS	
15.247 (c)	Radiated Spurious Emission	PASS	
15.247 (d)	Power Spectral Density	PASS	
15.203	Antenna Requirement	PASS	

**NOTE:**

(1) "N/A" denotes test is not applicable in this Test Report

## 1.1 TEST FACILITY

NTEK Testing Technology Co., Ltd.

Add. : 1/F, Building E, Fenda Science Park, Sanwei Community, Xixiang Street, Bao'an District, Shenzhen P.R. China

## 1.2 MEASUREMENT UNCERTAINTY

The reported uncertainty of measurement  $y \pm U$ , where expanded uncertainty  $U$  is based on a standard uncertainty multiplied by a coverage factor of  $k=2$ , providing a level of confidence of approximately **95 %**.

A. Conducted Measurement :

Test Site	Method	Measurement Frequency Range	U , (dB)	NOTE
C01	ANSI	150 KHz ~ 30MHz	1.94	

B. Radiated Measurement :

No.	Item	Uncertainty
1	Conducted Emission Test	$\pm 1.38\text{dB}$
2	Radiated Emission Test	$\pm 3.17\text{dB}$
3	RF power,conducted	$\pm 0.16\text{dB}$
4	Spurious emissions,conducted	$\pm 0.21\text{dB}$
5	All emissions,radiated(<1G)	$\pm 4.68\text{dB}$
6	All emissions,radiated(>1G)	$\pm 4.89\text{dB}$

## 2. GENERAL INFORMATION

### 2.1 GENERAL DESCRIPTION OF EUT

Equipment	IEEE 802.11b/g/n Long-Range USB Adapter	
Trade Name	ALFA	
Model Name	AWUS036NHR, UBDo-nr, UBDo-ntr, UBDo-nr8	
OEM Brand/Model Name	N/A	
Product Description	The EUT is a Dreampad	
	Operation Frequency:	802.11b: 2412~2462 MHz 802.11g: 2412~2462 MHz 802.11n(20MHzchannel): 2412~2462 MHz 802.11n(40MHzchannel): 2422~2452 MHz
	Modulation Type:	CCK/OFDM/DBPSK/DAPSK
	Bit Rate of Transmitter	802.11b:11/5.5/2/1 Mbps 802.11g:54/48/36/24/18/12/9/6 Mbps 802.11n(20MHz):72 Mbps 802.11n(40MHz):150 Mbps
	Number Of Channel	11 CH, Please see Note 2.
	Antenna Designation:	Please see Note 3.
	Antenna Gain(Peak)	Please see Note 3.
	Output Power:	802.11b: 26.83 dBm (Max.) 802.11g: 26.27dBm (Max.) 802.11n (20MHz):25.79dBm(Max) 802.11n (40MHz):25.96dBm(Max)
	Based on the application, features, or specification exhibited in User's Manual, the EUT is considered as an ITE/Computing Device. More details of EUT technical specification, please refer to the User's Manual.	
	Channel List	Please refer to the Note 2.
Power Source	DC 5V from PC	
Power Rating	DC 5V(USB)	
Connecting I/O Port(s)	Please refer to the User's Manual	
Products Covered	N/A	

Note

:

1. For a more detailed features description, please refer to the manufacturer's specifications or the User's Manual.

2.

Channel List							
Channel	Frequency (MHz)	Channel	Frequency (MHz)	Channel	Frequency (MHz)	Channel	Frequency (MHz)
01	2412	04	2427	07	2442	10	2457
02	2417	05	2432	08	2447	11	2462
03	2422	06	2437	09	2452		

3.

Table for Filed Antenna

Ant	Brand	Model Name	Antenna Type	Connector	Gain (dBi)	NOTE
1	N/A	N/A	External Omni Antenna	Reserve N-type	1.1	N/A



**2.2 DESCRIPTION OF TEST MODES**

To investigate the maximum EMI emission characteristics generates from EUT, the test system was pre-scanning tested base on the consideration of following EUT operation mode or test configuration mode which possible have effect on EMI emission level. Each of these EUT operation mode(s) or test configuration mode(s) mentioned above was evaluated respectively.

Pretest Mode	Description
Mode 1	802.11b CH1/ CH6/ CH11
Mode 2	802.11g CH1/ CH6/ CH11
Mode 3	802.11n CH1/ CH6/ CH11
Mode 4	802.11n CH3/ CH6/ CH9

For Conducted Emission	
Final Test Mode	Description
TX	NORMAL LINK

For Radiated Emission	
Final Test Mode	Description
Mode 1	802.11b CH1/ CH6/ CH11
Mode 2	802.11g CH1/ CH6/ CH11
Mode 3	802.11n CH1/ CH6/ CH11
Mode 4	802.11n CH3/ CH6/ CH9

Note:

- (1) The measurements are performed at the highest, middle, lowest available channels.

**2.3 TABLE OF PARAMETERS OF TEXT SOFTWARE SETTING**

During testing channel & power controlling software provided by the customer was used to control the operating channel as well as the output power level. The RF output power selection is for the setting of RF output power expected by the customer and is going to be fixed on the firmware of the final end product power parameters of WLAN

Test software Version	Test program: MP_Kit_RTL11n_SingleChip_9xC_USB_v024		
	2412 MHz	2437 MHz	2462 MHz
802.11b	42	42	42
802.11g	45	45	45
802.11n(20M)	45	45	45
802.11n(40M)	45	45	45

## 2.4 BLOCK DIGRAM SHOWING THE CONFIGURATION OF SYSTEM TESTED

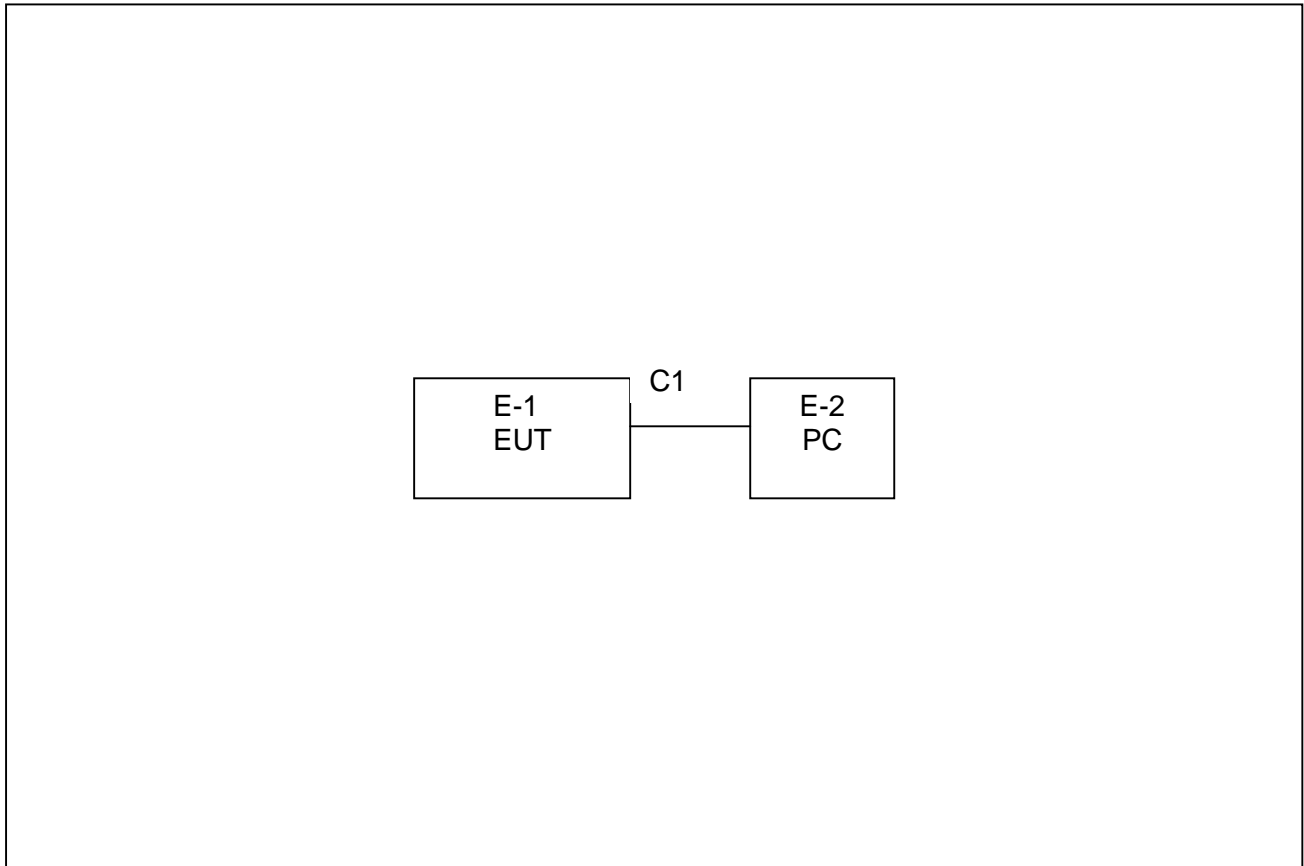

**2.5 DESCRIPTION OF SUPPORT UNITS(CONDUCTED MODE)**

The EUT has been tested as an independent unit together with other necessary accessories or support units. The following support units or accessories were used to form a representative test configuration during the tests.

Item	Equipment	Mfr/Brand	Model/Type No.	Series No.	Note
E-1	IEEE 802.11b/g/n Long-Range USB Adapter	ALFA	AWUS036NHR	N/A	EUT
E-2	Notebook computer	IBM	2366	N/A	AU

Item	Shielded Type	Ferrite Core	Length	Note
C1	NO	NO	2m	

Note:

- (1) The support equipment was authorized by Declaration of Confirmation.
- (2) For detachable type I/O cable should be specified the length in m in 『Length』 column.

**2.6 EQUIPMENTS LIST FOR ALL TEST ITEMS**

<b>Radiation Test Equipment:</b>					
No	Test Equipment	Manufacturer	Model No	Serial No	Cal. Due Date dd-mm-yy
1	Spectrum Analyzer	Agilent	E4407B	160400005	2012-4-24
2	Test Receiver	R&S	ESPI7	101318	2012-4-24
3	Bilog Antenna	TESEQ	CBL6111D	31216	2012-4-24
4	50Ω Coaxial Switch	Anritsu	MP59B	620026441 6	2012-4-24
5	Spectrum Analyzer	ADVANTEST	R3182	150900201	2012-4-24
6	Low Noise Pre Amplifier	Tsj	MLA-0120-A02-34	2648A0473 8	2012-4-24
7	Broadband Horn Antenna	SCHWARZBEC K	BBHA9120D	451	2012-4-24
8	Loop Antenna	ARA	PLA-1030/B	1029	2012-3-19

<b>Conduction Test equipment</b>					
No	Test Equipment	Manufacturer	Model No	Serial No	Cal. Due Date dd-mm-yy
1**	Test Receiver	R&S	ESCI	101160	2012-4-24
2	LISN	R&S	ENV216	101313	2012-4-24
3	LISN	Kyoritsu	KNW-407	8-1789-3	2012-4-24
4**	50Ω Coaxial Switch	Anritsu	MP59B	620026441 7	2012-4-24
5	Passive Voltage Probe	R&S	ESH2-Z3	100196	2012-4-24
6	Absorbing clamp	R&S	MDS-21	100423	2012-4-24

### 3. EMC EMISSION TEST

#### 3.1 CONDUCTED EMISSION MEASUREMENT

##### 3.1.1 POWER LINE CONDUCTED EMISSION Limits (Frequency Range 150KHz-30MHz)

FREQUENCY (MHz)	Class A (dBuV)		Class B (dBuV)		Standard
	Quasi-peak	Average	Quasi-peak	Average	
0.15 -0.5	79.00	66.00	66 - 56 *	56 - 46 *	CISPR
0.50 -5.0	73.00	60.00	56.00	46.00	CISPR
5.0 -30.0	73.00	60.00	60.00	50.00	CISPR

0.15 -0.5	79.00	66.00	66 - 56 *	56 - 46 *	FCC
0.50 -5.0	73.00	60.00	56.00	46.00	FCC
5.0 -30.0	73.00	60.00	60.00	50.00	FCC

Note:

- (1) The tighter limit applies at the band edges.
- (2) The limit of " \* " marked band means the limitation decreases linearly with the logarithm of the frequency in the range.

The following table is the setting of the receiver

Receiver Parameters	Setting
Attenuation	10 dB
Start Frequency	0.15 MHz
Stop Frequency	30 MHz
IF Bandwidth	9 kHz

### 3.1.2 TEST PROCEDURE

- a. The EUT was placed 0.4 meters from the horizontal ground plane with EUT being connected to the power mains through a line impedance stabilization network (LISN). All other support equipments powered from additional LISN(s). The LISN provide 50 Ohm/ 50uH of coupling impedance for the measuring instrument.
- b. Interconnecting cables that hang closer than 40 cm to the ground plane shall be folded back and forth in the center forming a bundle 30 to 40 cm long.
- c. I/O cables that are not connected to a peripheral shall be bundled in the center. The end of the cable may be terminated, if required, using the correct terminating impedance. The overall length shall not exceed 1 m.
- d. LISN at least 80 cm from nearest part of EUT chassis.
- e. For the actual test configuration, please refer to the related Item –EUT Test Photos.

### 3.1.3 DEVIATION FROM TEST STANDARD

No deviation

### 3.1.4 TEST SETUP

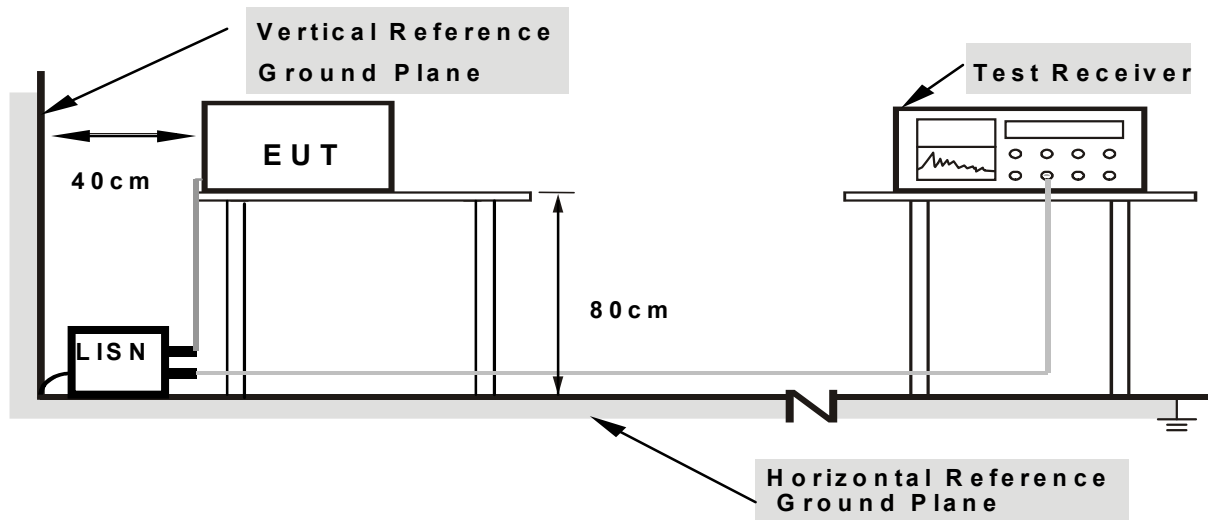

**Note: 1.Support units were connected to second LISN .**

**2.Both of LISNs (AMN) are 80 cm from EUT and at least 80 from other units and other metal planes**

### **3.1.5 EUT OPERATING CONDITIONS**

The EUT was configured for testing in a typical fashion (as a customer would normally use it). The EUT has been programmed to continuously transmit during test. This operating condition was tested and used to collect the included data.

### 3.1.6 TEST RESULTS

EUT :	IEEE 802.11b/g/n Long-Range USB Adapter	Model Name. :	AWUS036NHR
Temperature :	26 °C	Relative Humidity :	54%
Pressure :	1010hPa	Test Date :	2011-9-22
Test Mode :	Normal Link	Phase :	L
Test Voltage :	DC 5V From PC AC 120V/60Hz		

No.	Frequency (MHz)	Reading (dBuV)	Correction (dB)	Result (dBuV)	Limit (dBuV)	Margin (dB)	Remark
1	0.1700	50.44	10.35	60.79	64.96	-4.17	peak
2	0.1740	40.74	10.36	51.10	54.77	-3.67	AVG
3	1.8340	33.18	10.44	43.62	56.00	-12.38	peak
4	1.8340	32.89	10.44	43.33	46.00	-2.67	AVG
5	7.6580	31.28	10.68	41.96	50.00	-8.04	AVG
6	7.9860	34.53	10.69	45.22	60.00	-14.78	peak

Remark:

1. All readings are Quasi-Peak and Average values.
2. Factor = Insertion Loss + Cable Loss.
3. '\*' means the worst case

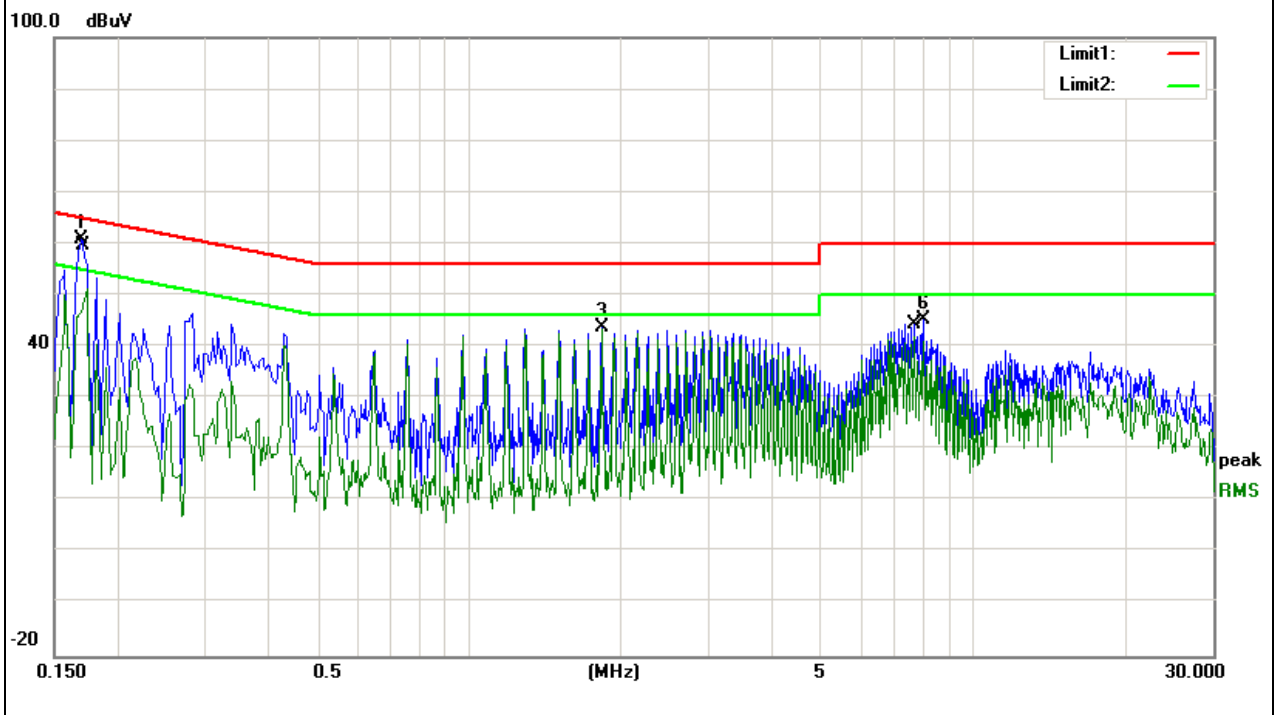



EUT :	IEEE 802.11b/g/n Long-Range USB Adapter	Model Name. :	AWUS036NHR
Temperature :	26 °C	Relative Humidity :	54%
Pressure :	1010hPa	Test Date :	2011-9-22
Test Mode :	Normal Link	Phase :	N
Test Voltage :	DC 5V From PC AC 120V/60Hz		

No.	Frequency (MHz)	Reading (dBuV)	Correction (dB)	Result (dBuV)	Limit (dBuV)	Margin (dB)	Remark
1	0.1660	48.26	10.45	58.71	65.16	-6.45	peak
2	0.1660	37.22	10.45	47.67	55.16	-7.49	AVG
3	8.0900	31.28	10.68	41.96	60.00	-18.04	peak
4	8.0900	28.94	10.68	39.62	50.00	-10.38	AVG
5	15.6380	31.29	10.71	42.00	60.00	-18.00	peak
6	15.6380	28.85	10.71	39.56	50.00	-10.44	AVG

Remark:

1. All readings are Quasi-Peak and Average values.
2. Factor = Insertion Loss + Cable Loss.
3. '\*' means the worst case

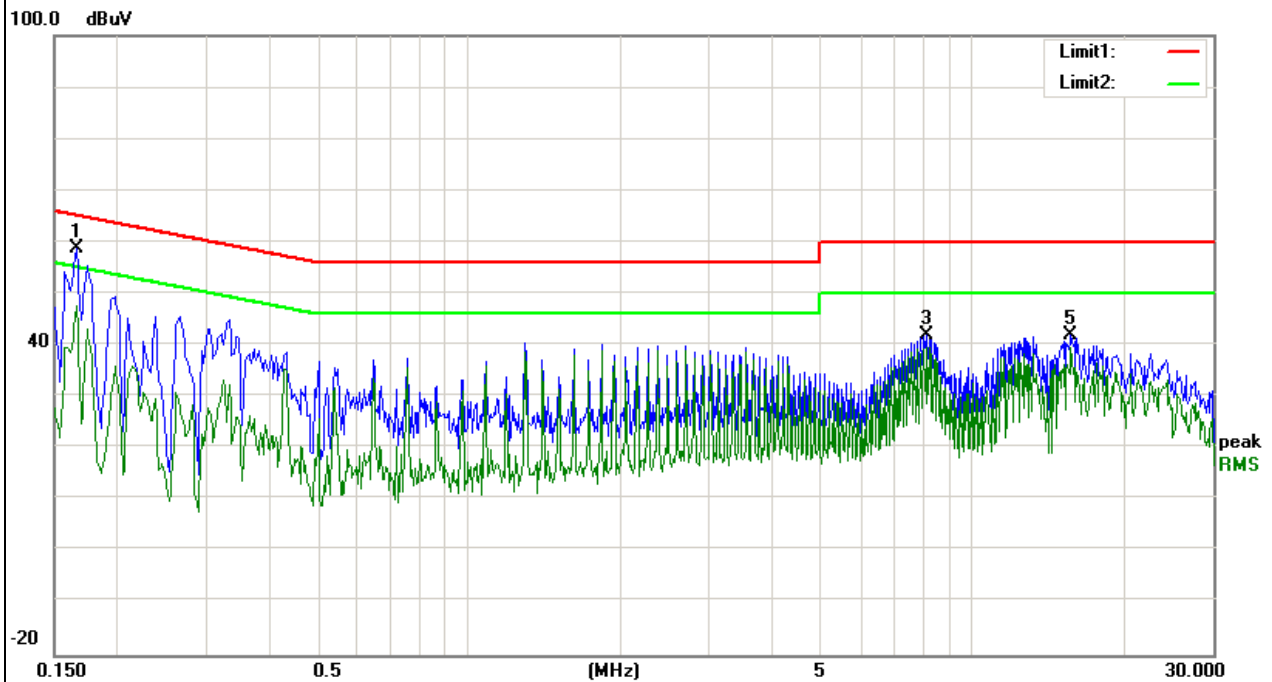

### 3.2 RADIATED EMISSION MEASUREMENT

#### 3.2.1 RADIATED EMISSION LIMITS (Frequency Range 9kHz-1000MHz)

20dBc in any 100 kHz bandwidth outside the operating frequency band. In case the emission fall within the restricted band specified on 15.205(a), then the 15.209(a) limit in the table below has to be followed.

Frequencies (MHz)	Field Strength (micorvolts/meter)	Measurement Distance (meters)
0.009~0.490	2400/F(KHz)	300
0.490~1.705	24000/F(KHz)	30
1.705~30.0	30	30
30~88	100	3
88~216	150	3
216~960	200	3
Above 960	500	3

#### LIMITS OF RADIATED EMISSION MEASUREMENT (Above 1000MHz)

FREQUENCY (MHz)	Class A (dBuV/m) (at 3M)		Class B (dBuV/m) (at 3M)	
	PEAK	AVERAGE	PEAK	AVERAGE
Above 1000	80	60	74	54

Notes:

- (1) The limit for radiated test was performed according to FCC PART 15C.
- (2) The tighter limit applies at the band edges.
- (3) Emission level (dBuV/m)=20log Emission level (uV/m).

Spectrum Parameter	Setting
Attenuation	Auto
Start Frequency	1000 MHz
Stop Frequency	10th carrier harmonic
RB / VB (emission in restricted band)	1 MHz / 1 MHz for Peak, 1 MHz / 10Hz for Average

Receiver Parameter	Setting
Attenuation	Auto
Start ~ Stop Frequency	9kHz~150kHz / RB 200Hz for QP
Start ~ Stop Frequency	150kHz~30MHz / RB 9kHz for QP
Start ~ Stop Frequency	30MHz~1000MHz / RB 120kHz for QP

### **3.2.2 TEST PROCEDURE**

- a. The measuring distance of at 3 m shall be used for measurements at frequency up to 1GHz. For frequencies above 1GHz, any suitable measuring distance may be used.
- b. The EUT was placed on the top of a rotating table 0.8 meters above the ground at a 3 meter open area test site. The table was rotated 360 degrees to determine the position of the highest radiation.
- c. The height of the equipment or of the substitution antenna shall be 0.8 m; the height of the test antenna shall vary between 1 m to 4 m. Both horizontal and vertical polarizations of the antenna are set to make the measurement.
- d. The initial step in collecting conducted emission data is a spectrum analyzer peak detector mode pre-scanning the measurement frequency range. Significant peaks are then marked and then Quasi Peak detector mode re-measured.
- e. If the Peak Mode measured value compliance with and lower than Quasi Peak Mode Limit, the EUT shall be deemed to meet QP Limits and then no additional QP Mode measurement performed.
- f. For the actual test configuration, please refer to the related Item –EUT Test Photos.

### **3.2.3 DEVIATION FROM TEST STANDARD**

No deviation

### 3.2.4 TEST SETUP

(A) Radiated Emission Test Set-Up, Frequency Below 1000MHz

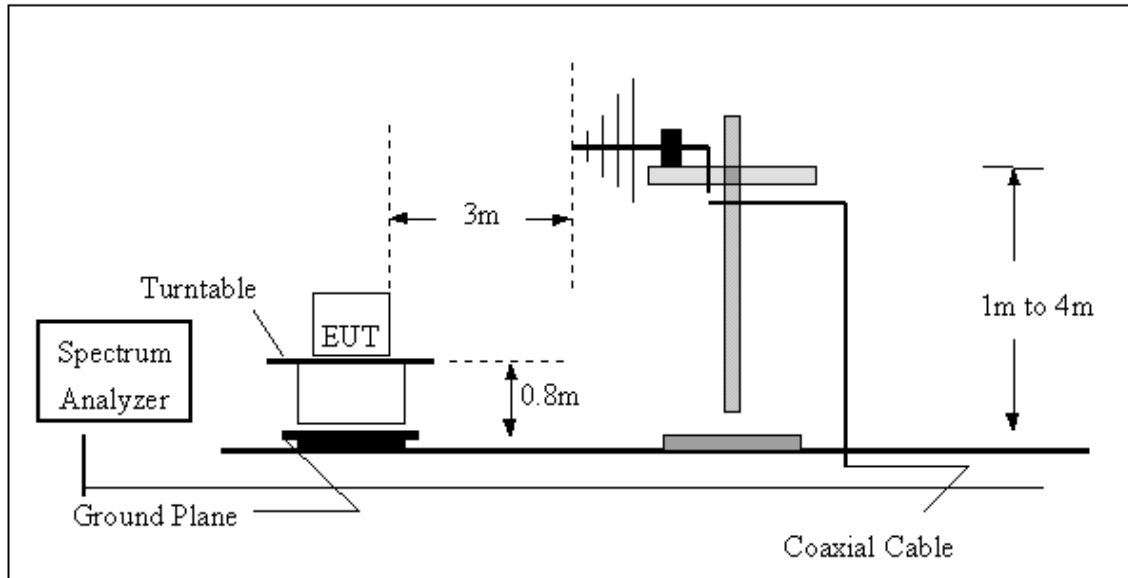

(B) Radiated Emission Test Set-Up Frequency Above 1 GHz

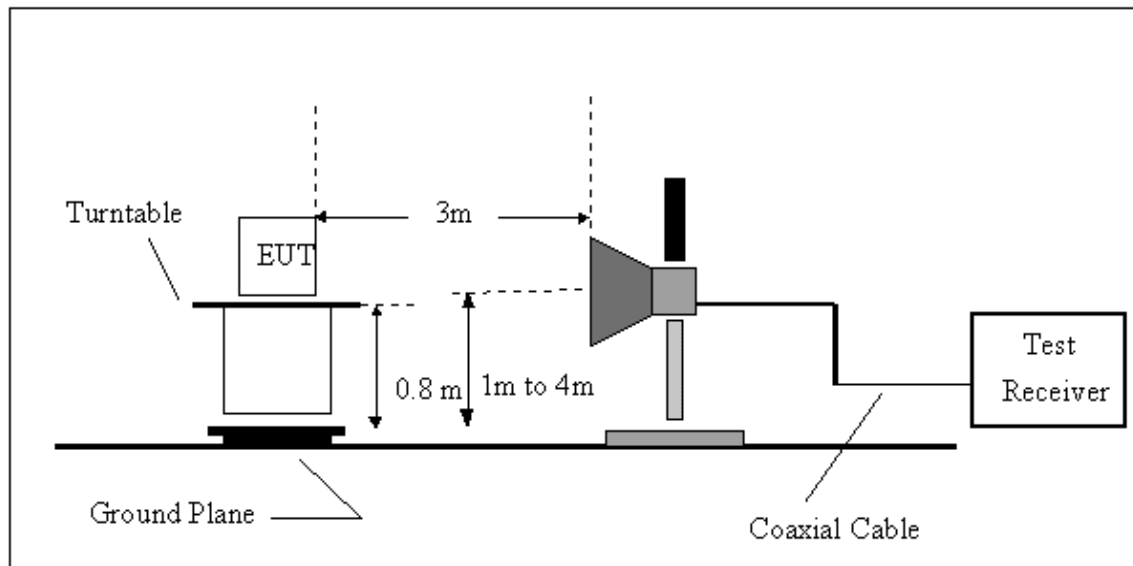

### 3.2.5 EUT OPERATING CONDITIONS

The EUT tested system was configured as the statements of 4.1.6 Unless otherwise a special operating condition is specified in the follows during the testing.

**3.2.6 TEST RESULTS (BETWEEN 9KHZ – 1000 MHZ)**

EUT :	IEEE 802.11b/g/n Long-Range USB Adapter	Model Name :	AWUS036NHR
Temperature :	20 °C	Relative Humidity :	48%
Pressure :	1010 hPa	Test Voltage :	DC 5V from PC
Test Mode :	TX	Polarization :	Horizontal

No.	Mk.	Freq. MHz	Reading Level dBuV	Correct Factor dB	Measure- ment dBuV/m	Limit dBuV/m	Over dB	Detector
1		83.2298	24.85	8.35	33.20	40.00	-6.80	QP
2		196.5098	26.45	8.69	35.14	43.50	-8.36	QP
3	*	355.4273	26.28	15.47	41.75	46.00	-4.25	QP

Remark:

- Factor = Antenna Factor + Cable Loss – Pre-amplifier.

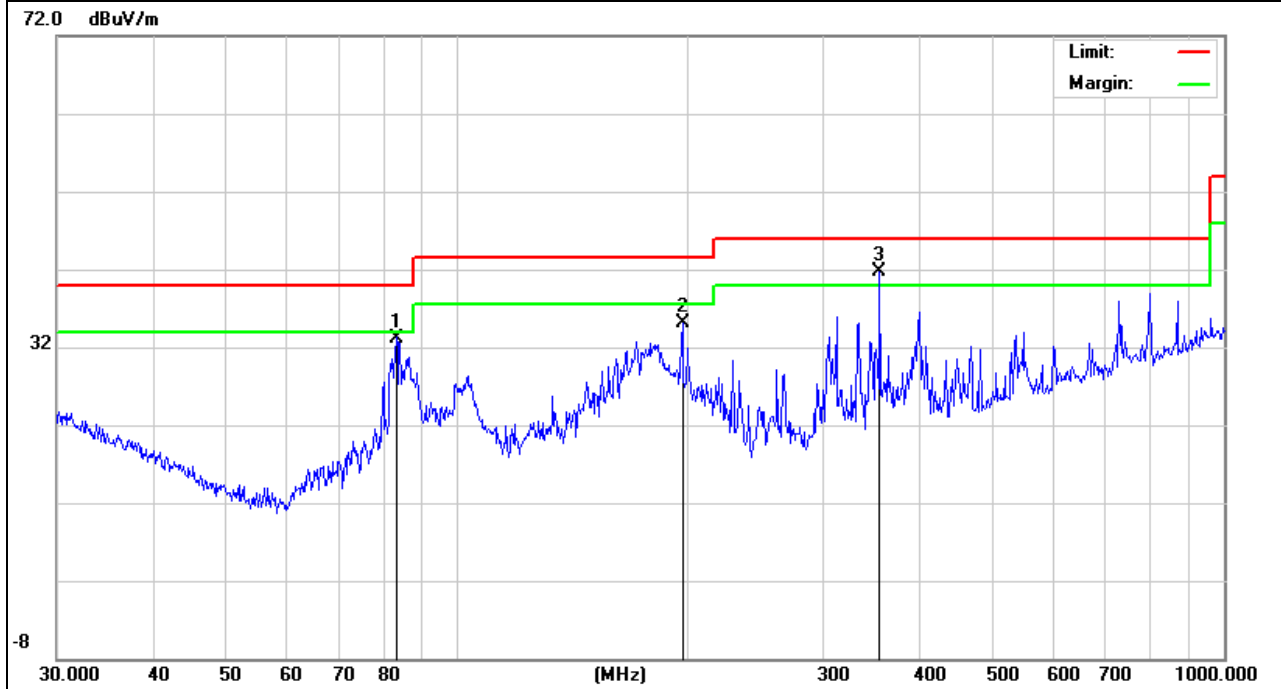

EUT :	IEEE 802.11b/g/n Long-Range USB Adapter	Model Name :	AWUS036NHR
Temperature :	20 °C	Relative Humidity :	48%
Pressure :	1010 hPa	Test Voltage :	DC 5V from PC
Test Mode :	TX	Polarization :	Vertical

No.	Mk.	Freq.	Reading Level	Correct Factor	Measurement	Limit	Over	Detector
		MHz	dBuV	dB	dBuV/m	dBuV/m	dB	
1		133.1511	22.85	11.96	34.81	43.50	-8.69	QP
2		467.2349	19.12	18.49	37.61	46.00	-8.39	QP
3	*	798.9797	14.68	23.84	38.52	46.00	-7.48	QP

Remark:

1. Factor = Antenna Factor + Cable Loss – Pre-amplifier.

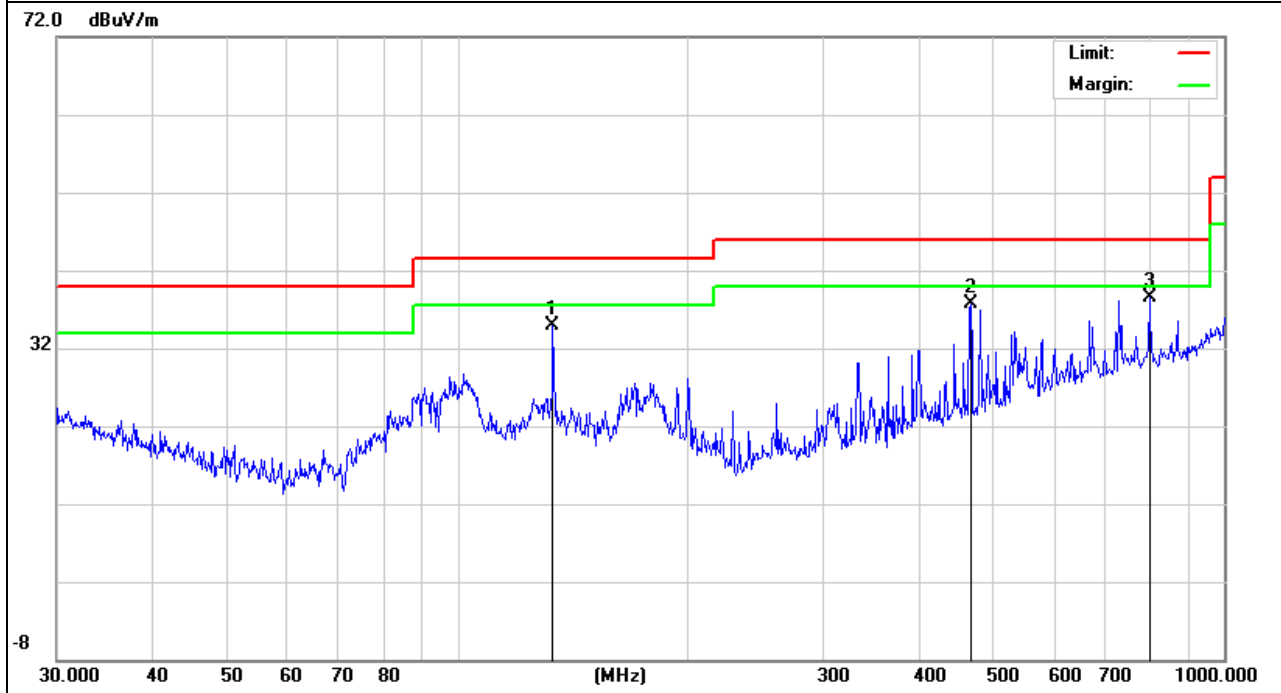

**3.2.7 TEST RESULTS (ABOVE 1000 MHZ)**

EUT :	IEEE 802.11b/g/n Long-Range USB Adapter	Model Name :	AWUS036NHR
Temperature :	20 °C	Relative Humidity :	48%
Pressure :	1010 hPa	Test Voltage :	DC 5V From PC
Test Mode :	CH1 (802.11b Mode)	Polarization :	Horizontal

Frequency (MHz)	Meter Reading (dBµV)	Factor (dB)	Emission Level (dBµV/m)	Limits (dBµV/m)	Margin (dB)	Detector Type
2400.00	21.31	32.65	52.96	74.00	-21.04	peak
2400.00	18.21	32.65	50.86	54.00	-3.14	AVG
4824.00	1.21	44.04	44.83	74.00	-29.17	peak
4824.00	-2.41	44.04	41.63	54.00	-12.37	AVG
7236.00	221	48.03	50.24	74.00	-23.76	peak
7236.00	-2.21	48.03	46.91	54.00	-7.09	AVG

Remark:

- Factor = Antenna Factor + Cable Loss – Pre-amplifier.

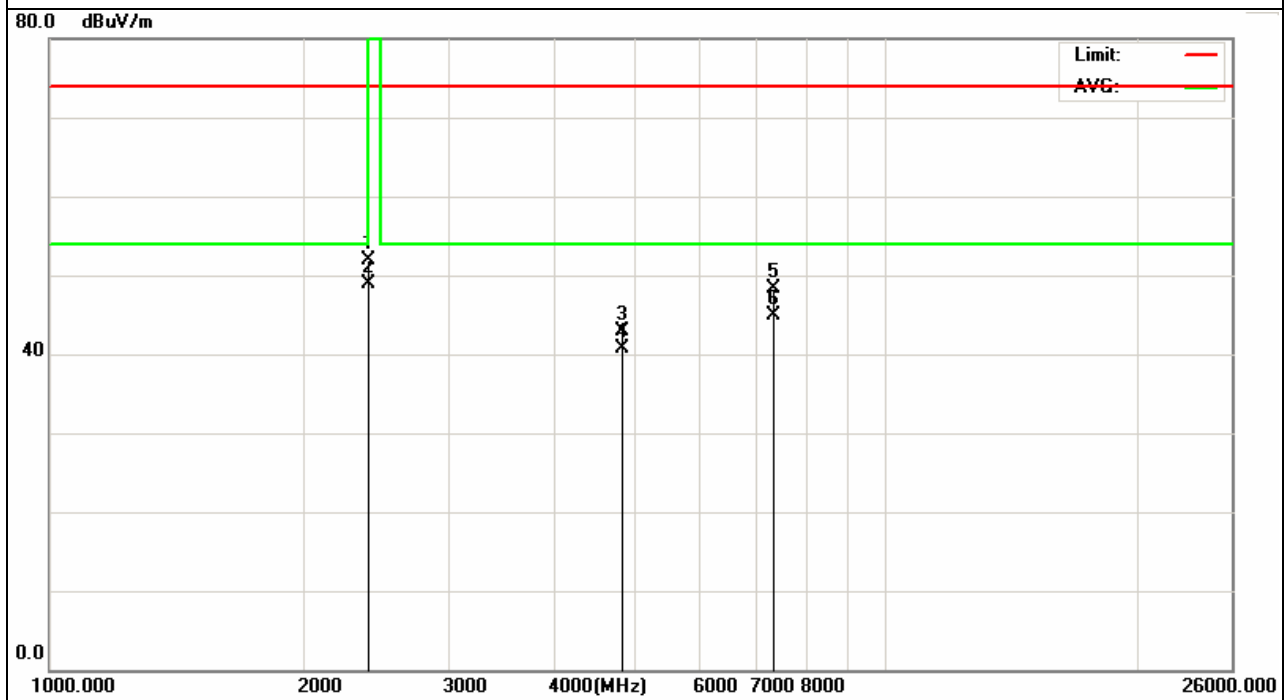

EUT :	IEEE 802.11b/g/n Long-Range USB Adapter	Model Name :	AWUS036NHR
Temperature :	20 °C	Relative Humidity :	48%
Pressure :	1010 hPa	Test Voltage :	DC5V from PC
Test Mode :	CH1 (802.11b Mode)	Polarization :	Vertical

Frequency (MHz)	Meter Reading (dBμV)	Factor (dB)	Emission Level (dBμV/m)	Limits (dBμV/m)	Margin (dB)	Detector Type
2400.00	17.21	32.65	49.86	74.00	-24.14	peak
2400.00	15.44	32.65	48.09	54.00	-5.91	AVG
4824.00	-1.44	44.04	42.60	74.00	-31.40	peak
4824.00	-5.44	44.04	38.60	54.00	-15.40	AVG
7326.00	-2.32	48.03	45.71	74.00	-28.29	peak
7326.00	-6.13	48.03	41.90	54.00	-12.10	AVG

Remark:

- Factor = Antenna Factor + Cable Loss – Pre-amplifier.

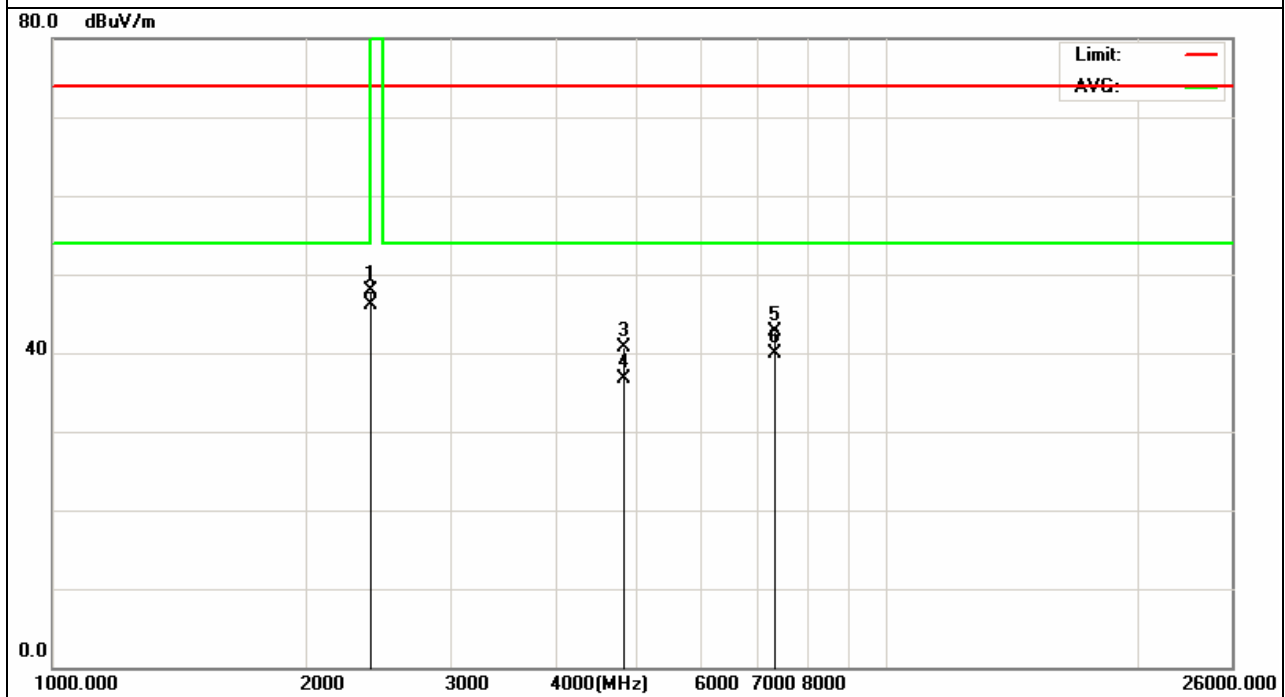



EUT :	IEEE 802.11b/g/n Long-Range USB Adapter	Model Name :	AWUS036NHR
Temperature :	20 °C	Relative Humidity :	48%
Pressure :	1010 hPa	Test Voltage :	DC5V from PC
Test Mode :	CH6 (802.11b Mode)	Polarization :	Horizontal

Frequency (MHz)	Meter Reading (dBµV)	Factor (dB)	Emission Level (dBµV/m)	Limits (dBµV/m)	Margin (dB)	Detector Type
4874.00	-1.13	44.07	42.94	74.00	-31.06	peak
4874.00	-2.25	44.07	41.82	54.00	-12.18	AVG
7311.00	-1.87	47.97	46.10	74.00	-27.90	peak
7311.00	-4.22	47.97	43.75	54.00	-10.25	AVG

Remark:

- Factor = Antenna Factor + Cable Loss – Pre-amplifier.

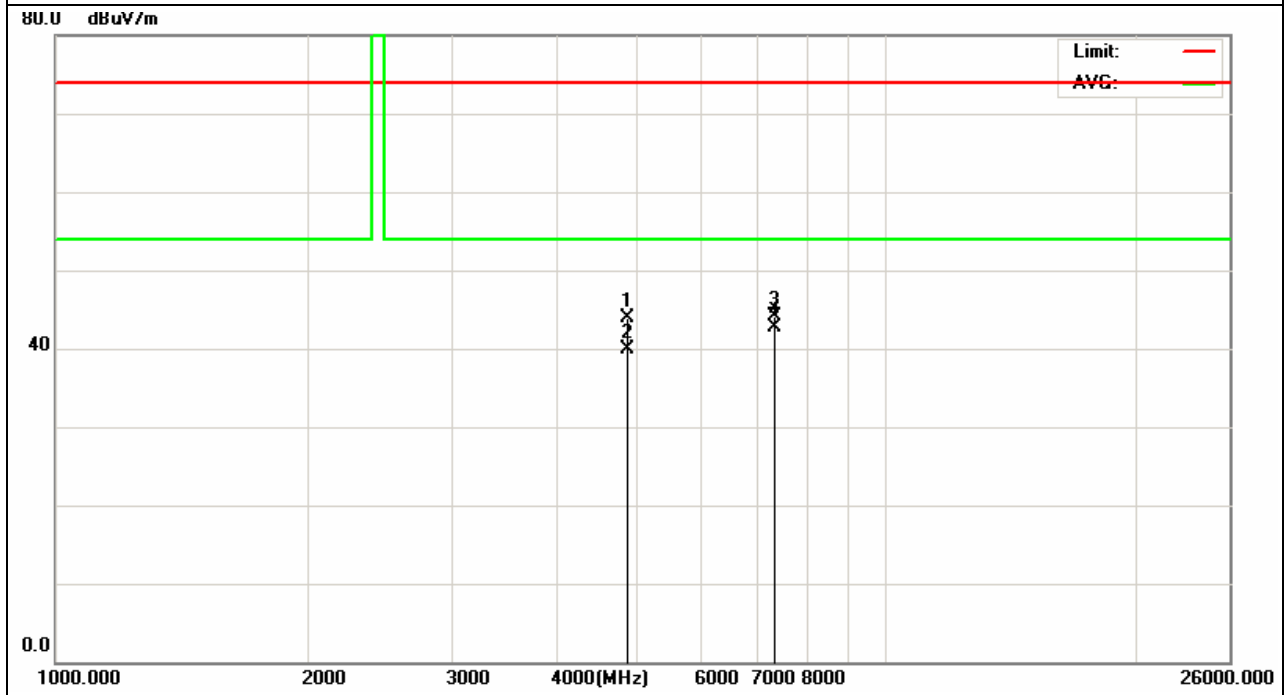

EUT :	IEEE 802.11b/g/n Long-Range USB Adapter	Model Name :	AWUS036NHR
Temperature :	20 °C	Relative Humidity :	48%
Pressure :	1010 hPa	Test Voltage :	DC5V from PC
Test Mode :	CH6 (802.11b Mode)	Polarization :	Vertical

Frequency (MHz)	Meter Reading (dBμV)	Factor (dB)	Emission Level (dBμV/m)	Limits (dBμV/m)	Margin (dB)	Detector Type
4874.00	4.32	44.07	48.39	74.00	-25.61	peak
4874.00	-0.54	44.07	43.53	54.00	-10.47	AVG
7311.00	3.54	47.97	51.51	74.00	-22.49	peak
7311.00	-1.31	47.97	46.66	54.00	-7.34	AVG

Remark:

- Factor = Antenna Factor + Cable Loss – Pre-amplifier.

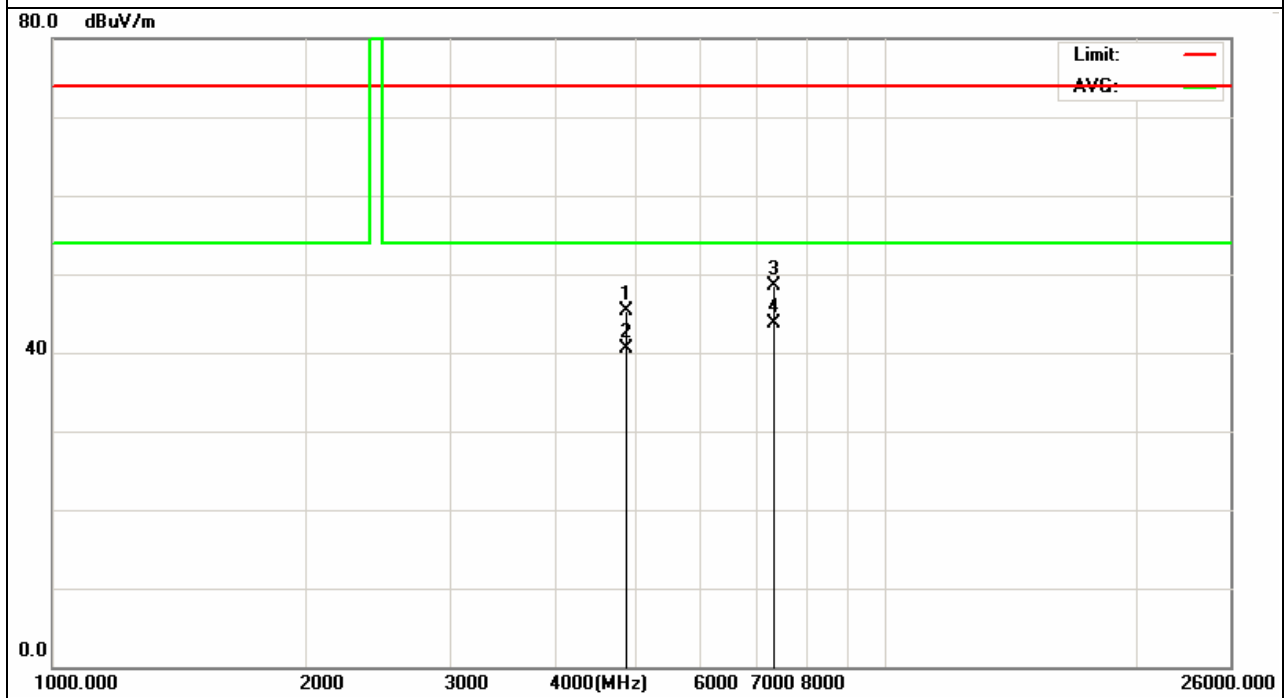

EUT :	IEEE 802.11b/g/n Long-Range USB Adapter	Model Name :	AWUS036NHR
Temperature :	20 °C	Relative Humidity :	48%
Pressure :	1010 hPa	Test Voltage :	DC5V from PC
Test Mode :	CH11 (802.11b Mode)	Polarization :	Horizontal

Frequency (MHz)	Meter Reading (dBµV)	Factor (dB)	Emission Level (dBµV/m)	Limits (dBµV/m)	Margin (dB)	Detector Type
2483.5	19.24	33.27	52.51	74.00	-21.49	peak
2483.5	14.33	33.27	47.60	54.00	-6.40	AVG
4924.00	4.31	44.10	48.41	74.00	-22.89	peak
4924.00	-5.31	44.10	38.79	54.00	-15.21	AVG
7386.00	-2.32	48.31	45.99	74.00	-28.01	peak
7386.00	-5.76	48.31	42.55	54.00	-11.45	AVG

Remark:

- Factor = Antenna Factor + Cable Loss – Pre-amplifier.

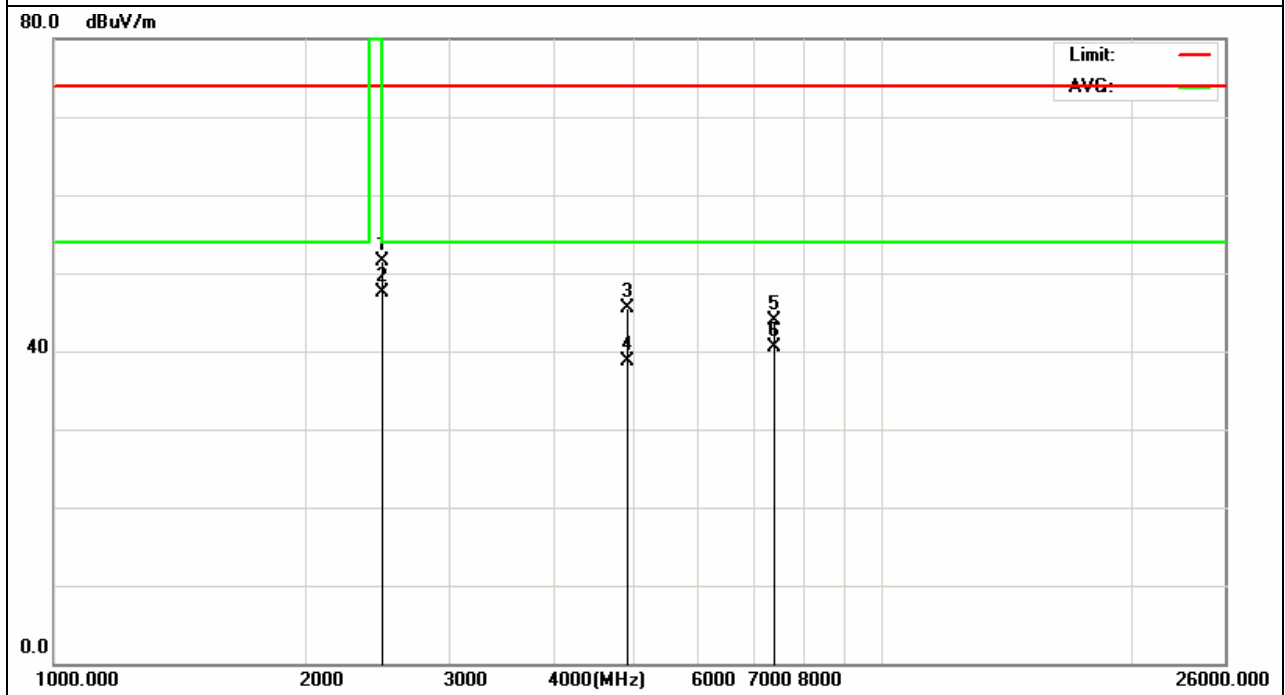

EUT :	IEEE 802.11b/g/n Long-Range USB Adapter	Model Name :	AWUS036NHR
Temperature :	20 °C	Relative Humidity :	48%
Pressure :	1010 hPa	Test Voltage :	DC5V from PC
Test Mode :	CH11 (802.11b Mode)	Polarization :	Vertical

Frequency (MHz)	Meter Reading (dBµV)	Factor (dB)	Emission Level (dBµV/m)	Limits (dBµV/m)	Margin (dB)	Detector Type
2483.5	54.11	4.36	58.47	74.00	-15.53	peak
2483.5	43.98	4.36	48.34	54.00	-5.66	AVG
4924.00	42.77	12.24	59.01	74.00	-14.99	peak
4924.00	35.51	12.24	47.75	54.00	-6.25	AVG
7386.00	37.58	18.50	56.08	74.00	-17.92	peak
7386.00	27.23	18.50	45.73	54.00	-8.27	AVG

Remark:

- Factor = Antenna Factor + Cable Loss – Pre-amplifier.

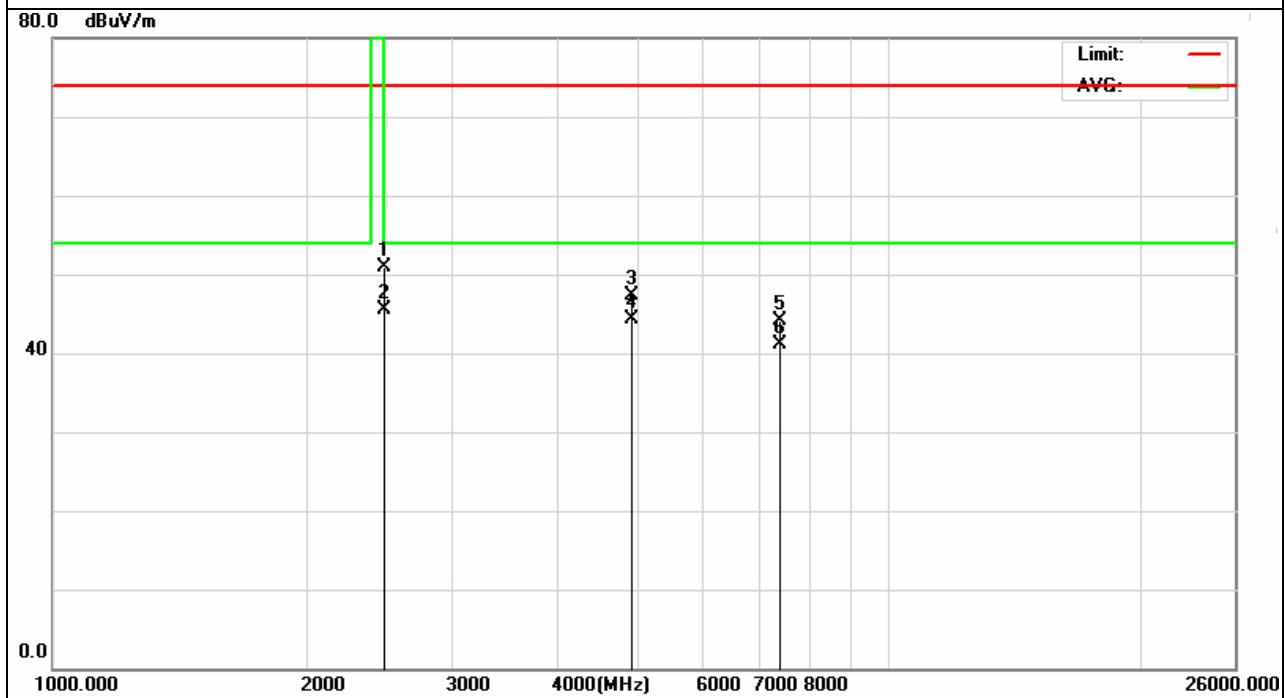

EUT :	IEEE 802.11b/g/n Long-Range USB Adapter	Model Name :	AWUS036NHR
Temperature :	20 °C	Relative Humidity :	48%
Pressure :	1010 hPa	Test Voltage :	DC5V from PC
Test Mode :	CH1 (802.11g Mode)	Polarization :	Horizontal

Frequency (MHz)	Meter Reading (dBµV)	Factor (dB)	Emission Level (dBµV/m)	Limits (dBµV/m)	Margin (dB)	Detector Type
2400.00	21.50	32.65	54.15	74.00	-19.85	peak
2400.00	16.23	32.65	48.88	54.00	-5.12	AVG
4824.00	2.23	44.04	46.27	74.00	-27.73	peak
4824.00	-1.43	44.04	42.61	54.00	-11.39	AVG
7236.00	1.21	48.03	49.24	74.00	-24.76	peak
7236.00	-2.23	48.03	45.80	54.00	-8.20	AVG

Remark:

- Factor = Antenna Factor + Cable Loss – Pre-amplifier.

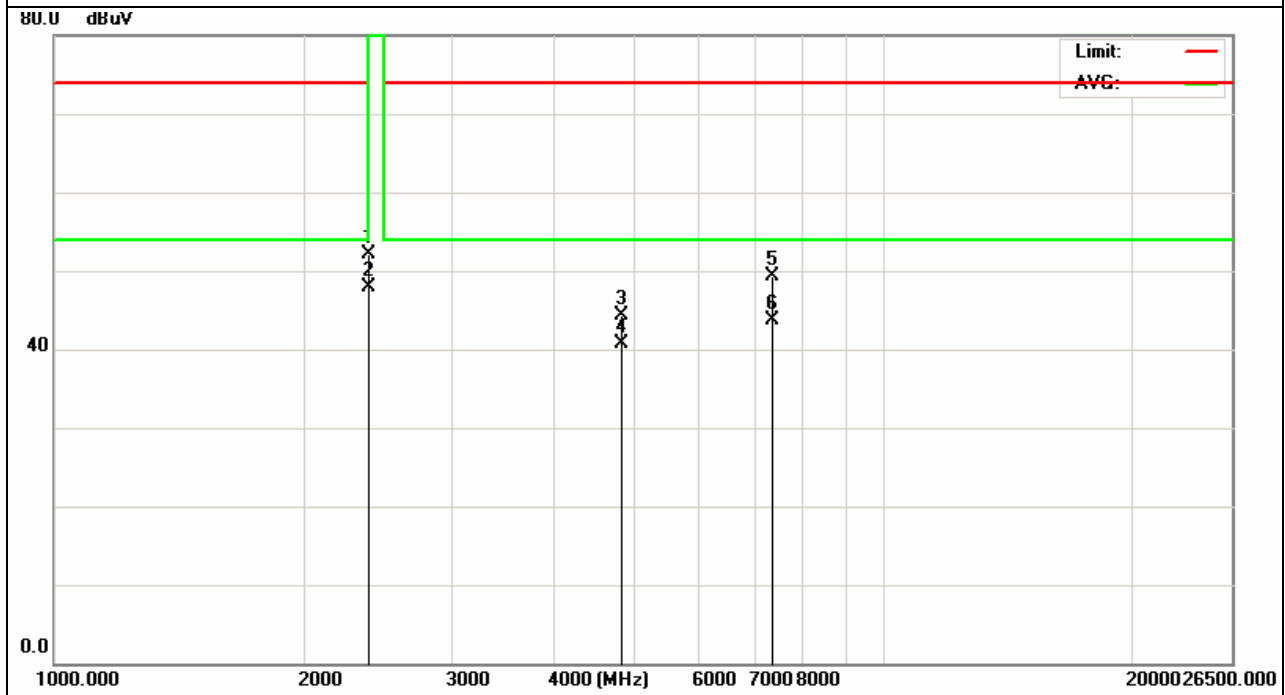

EUT :	IEEE 802.11b/g/n Long-Range USB Adapter	Model Name :	AWUS036NHR
Temperature :	20 °C	Relative Humidity :	48%
Pressure :	1010 hPa	Test Voltage :	DC5V from PC
Test Mode :	CH1 (802.11g Mode)	Polarization :	Vertical

Frequency (MHz)	Meter Reading (dBμV)	Factor (dB)	Emission Level (dBμV/m)	Limits (dBμV/m)	Margin (dB)	Detector Type
2400.00	20.09	32.65	52.74	74.00	-21.26	peak
2400.00	15.98	32.65	48.63	54.00	-5.37	AVG
4824.00	1.11	44.04	45.15	74.00	-28.85	peak
4824.00	-7.45	44.04	36.59	54.00	-17.41	AVG
7236.00	-3.33	47.63	44.30	74.00	-29.70	peak
7236.00	-5.43	47.63	42.20	54.00	-11.80	AVG

Remark:

- Factor = Antenna Factor + Cable Loss – Pre-amplifier.

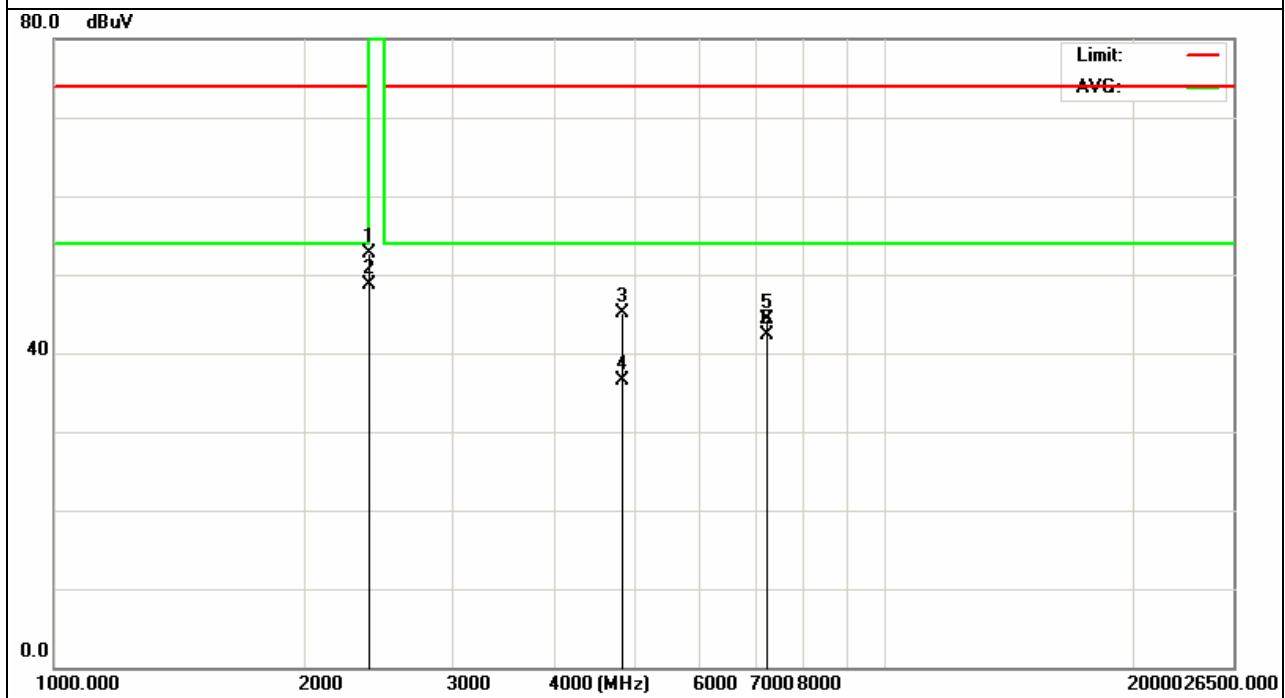

EUT :	IEEE 802.11b/g/n Long-Range USB Adapter	Model Name :	AWUS036NHR
Temperature :	20 °C	Relative Humidity :	48%
Pressure :	1010 hPa	Test Voltage :	DC5V from PC
Test Mode :	CH6 (802.11g Mode)	Polarization :	Horizontal

Frequency (MHz)	Meter Reading (dBμV)	Factor (dB)	Emission Level (dBμV/m)	Limits (dBμV/m)	Margin (dB)	Detector Type
4874.00	1.13	44.07	45.94	74.00	-28.06	peak
4874.00	-1.25	44.07	42.82	54.00	-11.18	AVG
7311.00	-3.87	47.97	44.10	74.00	-29.90	peak
7311.00	-5.22	47.97	42.75	54.00	-11.25	AVG

Remark:

- Factor = Antenna Factor + Cable Loss – Pre-amplifier.

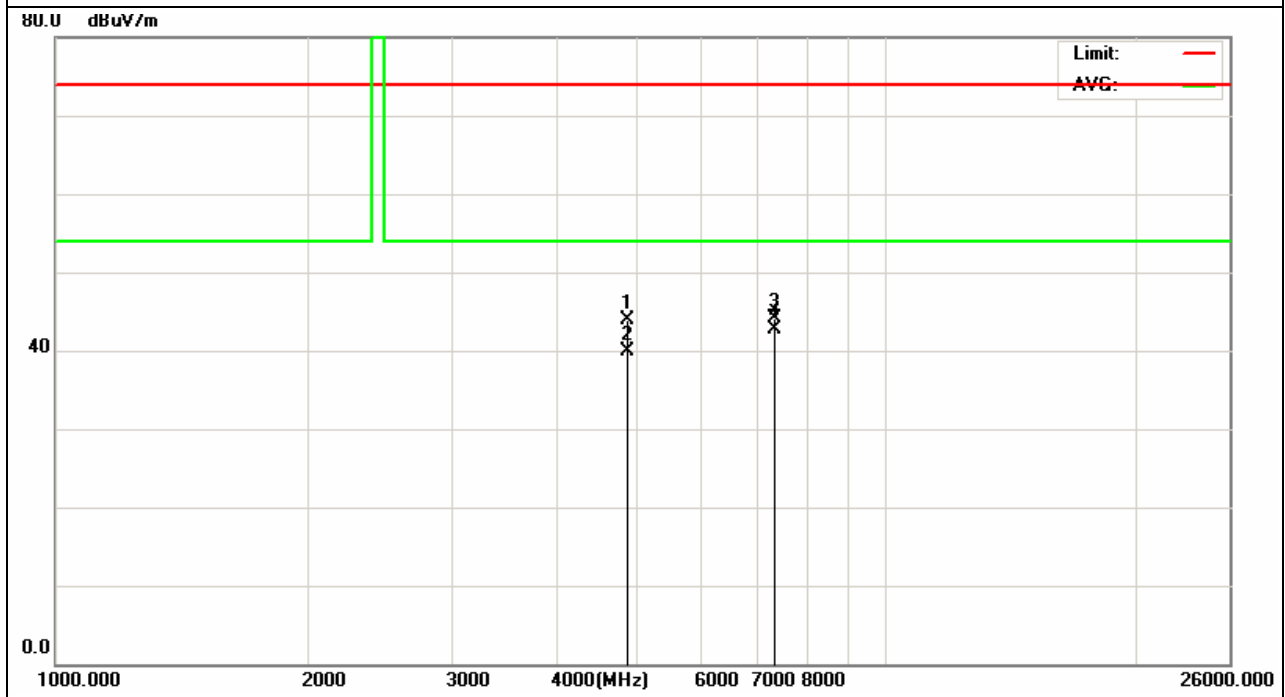

EUT :	IEEE 802.11b/g/n Long-Range USB Adapter	Model Name :	AWUS036NHR
Temperature :	20 °C	Relative Humidity :	48%
Pressure :	1010 hPa	Test Voltage :	DC5V from PC
Test Mode :	CH6 (802.11g Mode)	Polarization :	Vertical

Frequency (MHz)	Meter Reading (dBµV)	Factor (dB)	Emission Level (dBµV/m)	Limits (dBµV/m)	Margin (dB)	Detector Type
4874.00	4.32	44.07	48.39	74.00	-25.61	peak
4874.00	-2.54	44.07	41.53	54.00	-12.47	AVG
7311.00	0.54	47.97	48.51	74.00	-25.49	peak
7311.00	-4.31	47.97	43.66	54.00	-10.34	AVG

Remark:

- Factor = Antenna Factor + Cable Loss – Pre-amplifier.

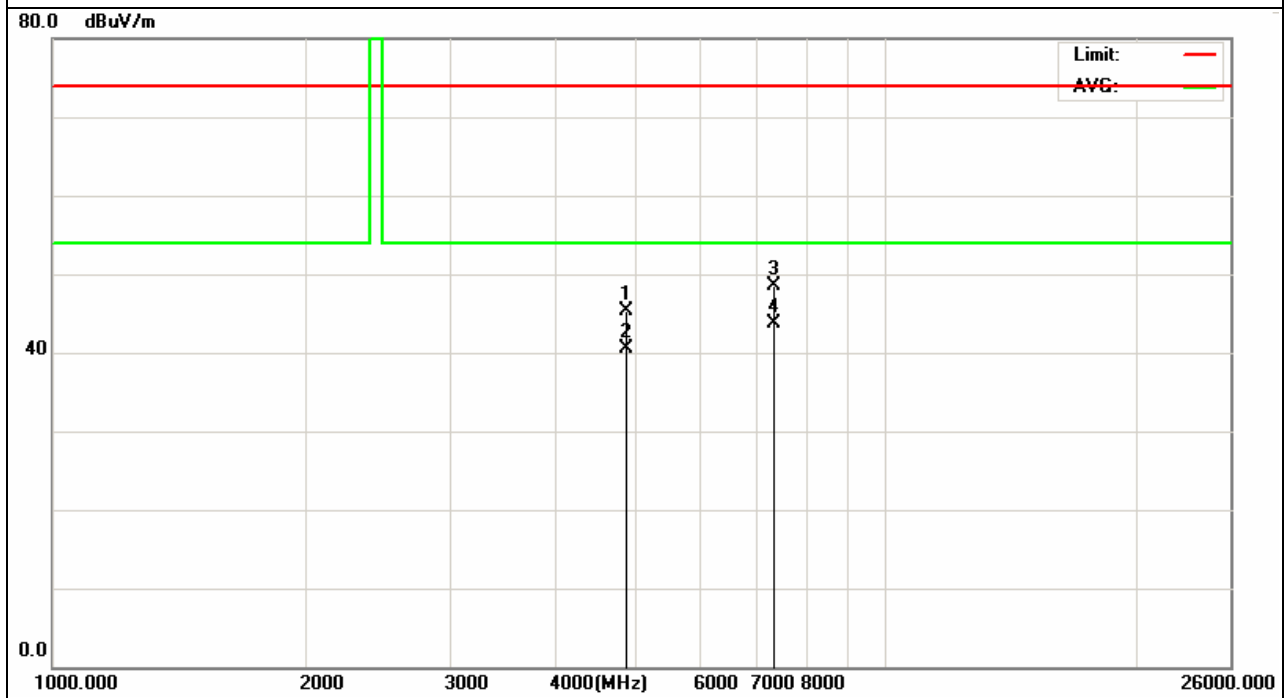



EUT :	IEEE 802.11b/g/n Long-Range USB Adapter	Model Name :	AWUS036NHR
Temperature :	20 °C	Relative Humidity :	48%
Pressure :	1010 hPa	Test Voltage :	DC5V from PC
Test Mode :	CH11 (802.11g Mode)	Polarization :	Horizontal

Frequency (MHz)	Meter Reading (dBµV)	Factor (dB)	Emission Level (dBµV/m)	Limits (dBµV/m)	Margin (dB)	Detector Type
2483.5	21.76	33.27	55.03	74.00	-19.97	peak
2483.5	14.43	33.27	47.70	54.00	-6.30	AVG
4924.00	9.43	44.10	53.53	74.00	-20.47	peak
4924.00	2.12	44.10	46.22	54.00	-7.78	AVG
7386.00	-4.15	48.31	44.16	74.00	-29.84	peak
7386.00	30.56	48.31	43.09	54.00	-10.91	AVG

Remark:

- Factor = Antenna Factor + Cable Loss – Pre-amplifier.

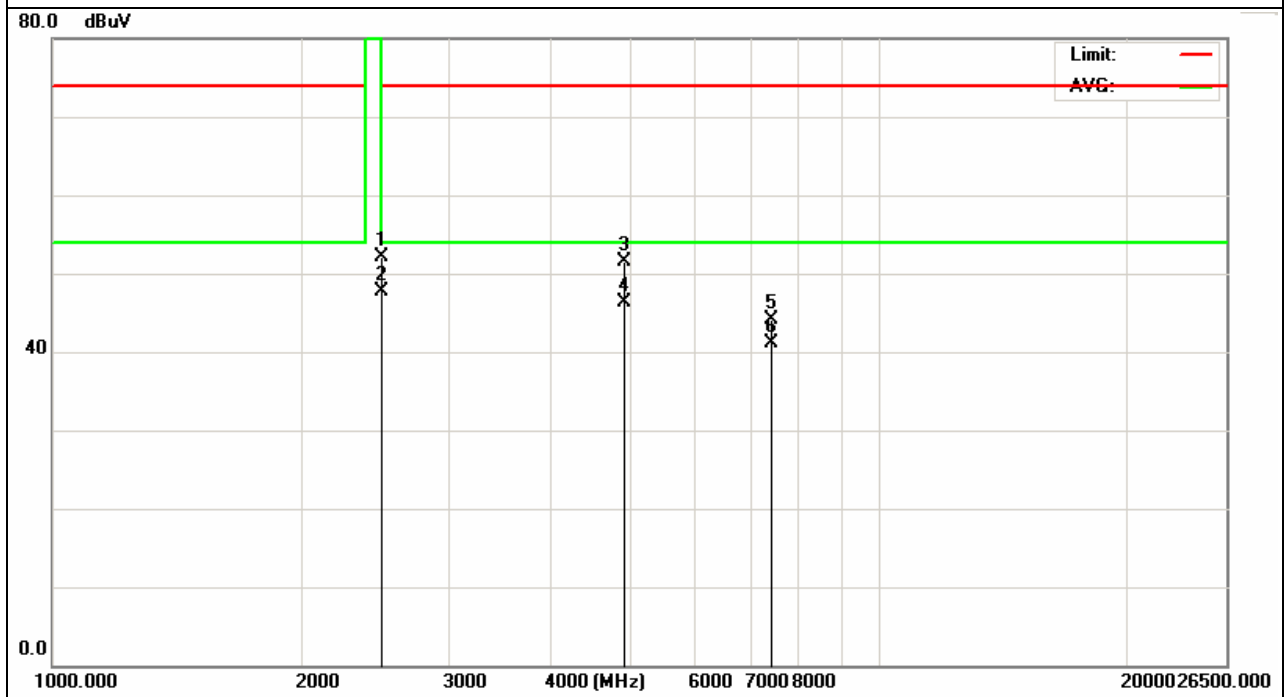

EUT :	IEEE 802.11b/g/n Long-Range USB Adapter	Model Name :	AWUS036NHR
Temperature :	20 °C	Relative Humidity :	48%
Pressure :	1010 hPa	Test Voltage :	DC5V from PC
Test Mode :	CH11(802.11g Mode)	Polarization :	Vertical

Frequency (MHz)	Meter Reading (dBµV)	Factor (dB)	Emission Level (dBµV/m)	Limits (dBµV/m)	Margin (dB)	Detector Type
2483.50	23.43	33.27	56.70	74.00	-17.30	peak
2483.50	15.34	33.27	48.61	54.00	-5.39	AVG
4924.00	8.67	44.10	52.77	74.00	-21.23	peak
4924.00	0.12	44.10	44.22	54.00	-9.78	AVG
7386.00	-1.21	48.31	47.10	74.00	-26.90	peak
7386.00	-8.13	48.31	40.18	54.00	-13.82	AVG

Remark:

- Factor = Antenna Factor + Cable Loss – Pre-amplifier.

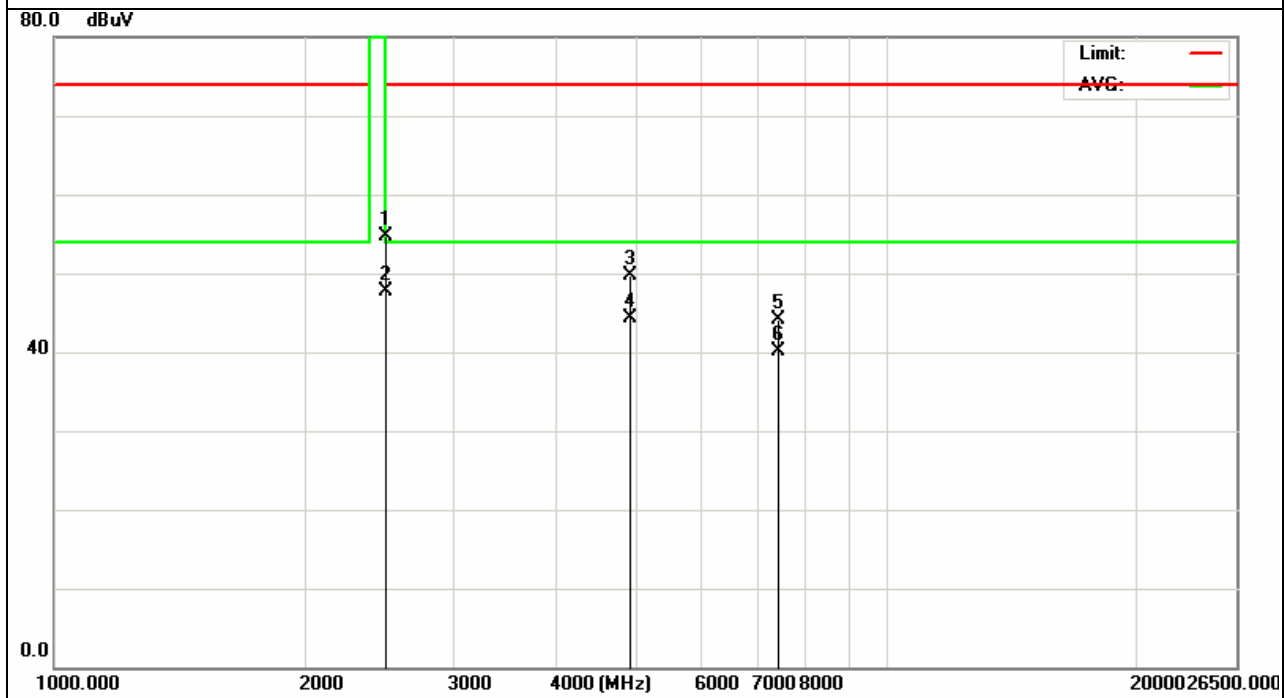

EUT :	IEEE 802.11b/g/n Long-Range USB Adapter	Model Name :	AWUS036NHR
Temperature :	20 °C	Relative Humidity :	48%
Pressure :	1010 hPa	Test Voltage :	DC5V from PC
Test Mode :	CH1 (802.11N Mode,20MHz)	Polarization :	Horizontal

Frequency (MHz)	Meter Reading (dBµV)	Factor (dB)	Emission Level (dBµV/m)	Limits (dBµV/m)	Margin (dB)	Detector Type
2400.00	20.12	34.65	50.77	74.00	-20.23	peak
2400.00	16.12	32.65	48.77	54.00	-5.23	AVG
4824.00	5.13	44.04	49.17	74.00	-24.83	peak
4824.00	-3.33	44.04	40.71	54.00	-13.29	AVG
7236.00	-3.14	48.03	44.89	74.00	-29.11	peak
7236.00	-9.22	48.03	38.81	54.00	-15.19	AVG

Remark:

- Factor = Antenna Factor + Cable Loss – Pre-amplifier.

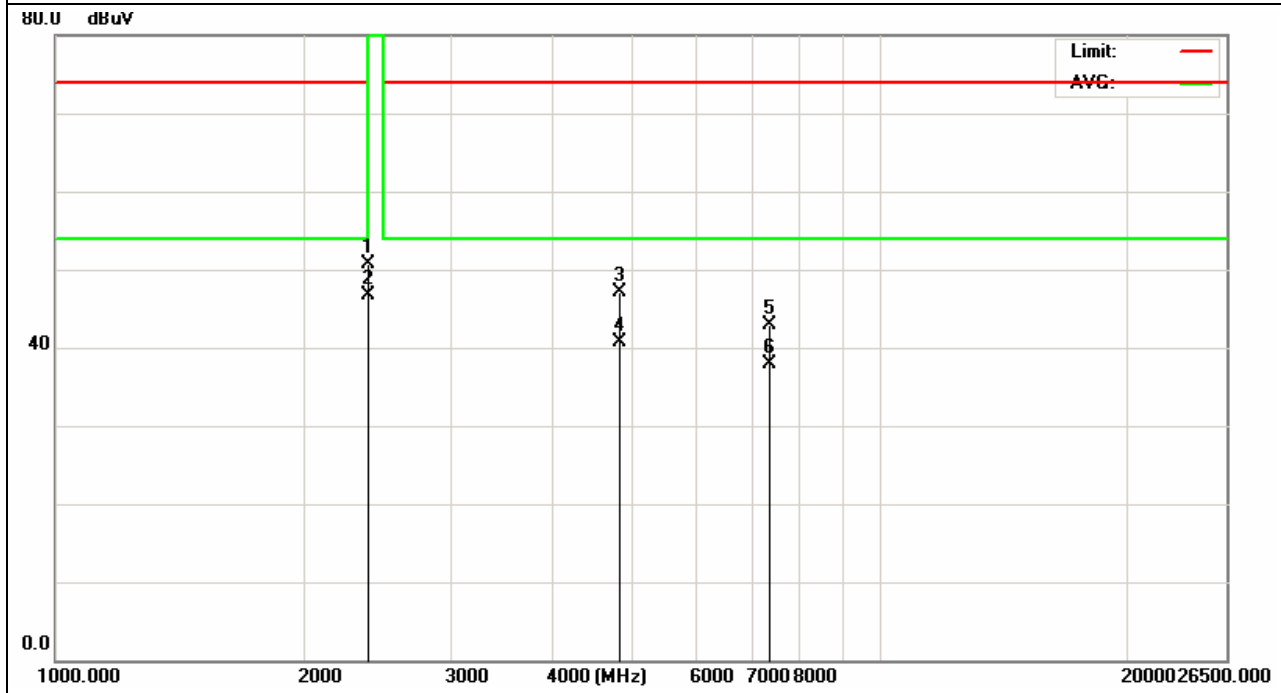

EUT :	IEEE 802.11b/g/n Long-Range USB Adapter	Model Name :	AWUS036NHR
Temperature :	20 °C	Relative Humidity :	48%
Pressure :	1010 hPa	Test Voltage :	DC5V from PC
Test Mode :	CH1 (802.11N Mode,20MHz)	Polarization :	Vertical

Frequency (MHz)	Meter Reading (dBμV)	Factor (dB)	Emission Level (dBμV/m)	Limits (dBμV/m)	Margin (dB)	Detector Type
2400.00	21.99	32.65	54.64	74.00	-19.36	peak
2400.00	15.98	32.65	48.63	54.00	-5.37	AVG
4824.00	6.96	44.04	51.00	74.00	-23.00	peak
4824.00	-1.10	44.04	42.90	54.00	-11.06	AVG
7236.00	2.13	48.03	49.90	74.00	-24.10	peak
7236.00	-6.18	48.03	41.85	54.00	-12.15	AVG

Remark:

- Factor = Antenna Factor + Cable Loss – Pre-amplifier.

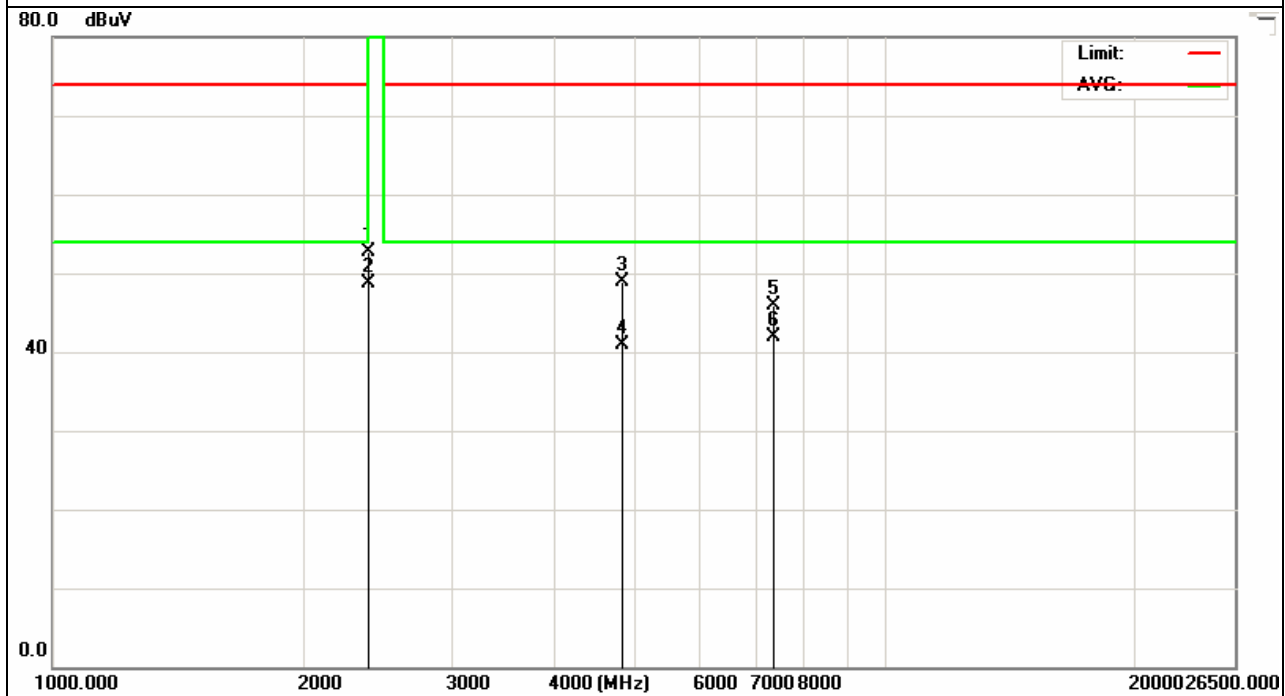

EUT :	IEEE 802.11b/g/n Long-Range USB Adapter	Model Name :	AWUS036NHR
Temperature :	20 °C	Relative Humidity :	48%
Pressure :	1010 hPa	Test Voltage :	DC5V from PC
Test Mode :	CH6 (802.11N Mode,20MHz)	Polarization :	Horizontal

Frequency (MHz)	Meter Reading (dBμV)	Factor (dB)	Emission Level (dBμV/m)	Limits (dBμV/m)	Margin (dB)	Detector Type
4874.00	4.24	44.07	48.07	74.00	-25.70	peak
4874.00	0.05	44.07	44.12	54.00	-9.88	AVG
7311.00	-3.11	47.97	44.86	74.00	-29.14	peak
7311.00	-7.11	47.97	40.86	54.00	-13.14	AVG

Remark:

- Factor = Antenna Factor + Cable Loss – Pre-amplifier.

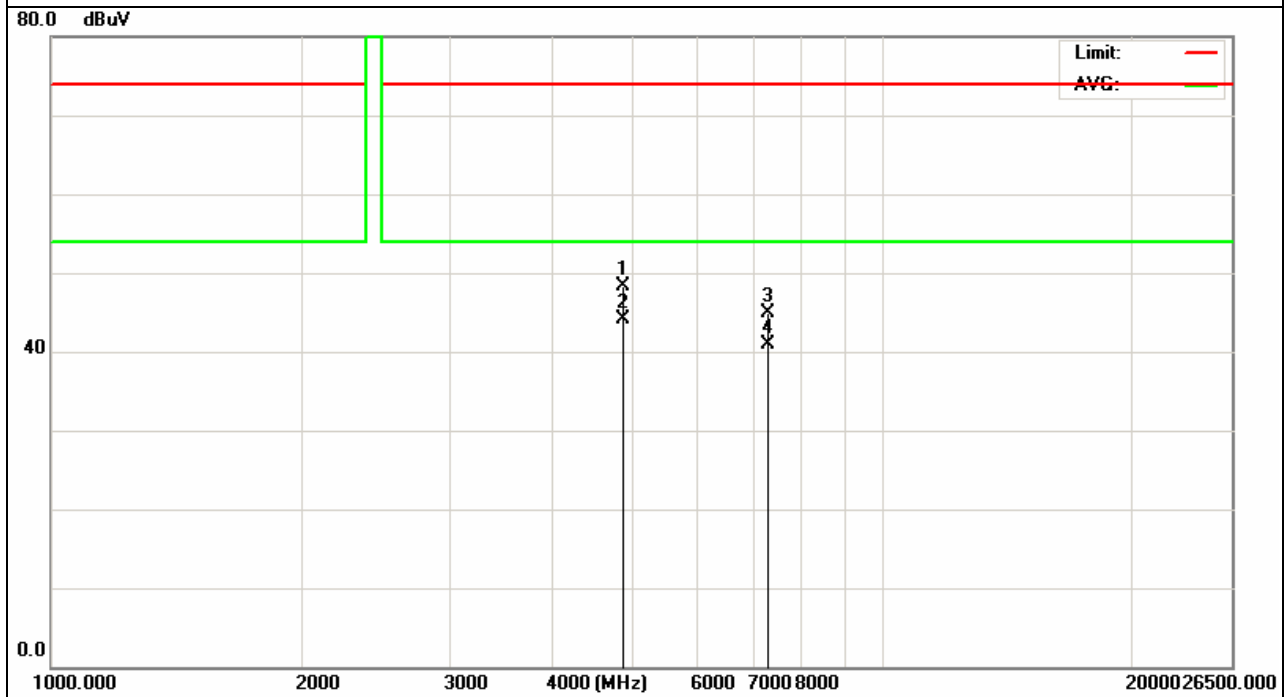

EUT :	IEEE 802.11b/g/n Long-Range USB Adapter	Model Name :	AWUS036NHR
Temperature :	20 °C	Relative Humidity :	48%
Pressure :	1010 hPa	Test Voltage :	DC5V from PC
Test Mode :	CH6 (802.11N Mode,20MHz)	Polarization :	Vertical

Frequency (MHz)	Meter Reading (dBµV)	Factor (dB)	Emission Level (dBµV/m)	Limits (dBµV/m)	Margin (dB)	Detector Type
4874.00	8.89	44.07	52.96	74.00	-21.04	peak
4874.00	0.11	44.07	43.96	54.00	-10.04	AVG
7311.00	1.21	47.97	48.76	74.00	-25.24	peak
7311.00	-4.34	47.97	43.63	54.00	-10.37	AVG

Remark:

- Factor = Antenna Factor + Cable Loss – Pre-amplifier.

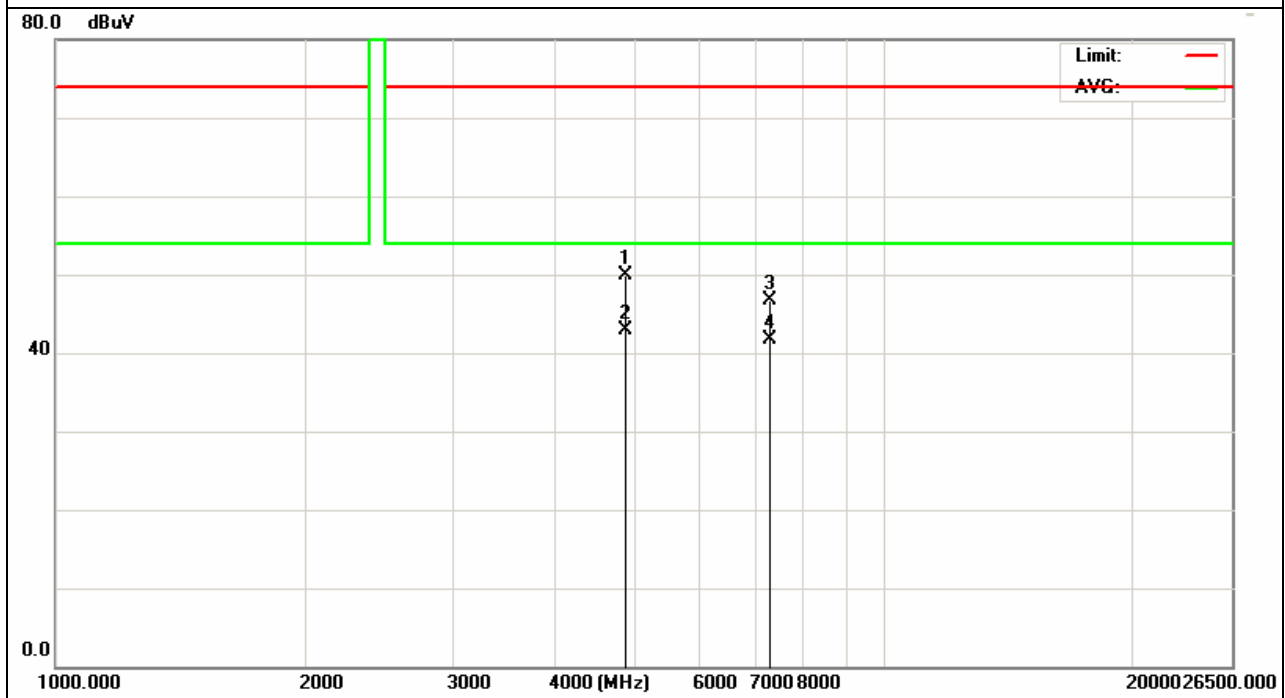

EUT :	IEEE 802.11b/g/n Long-Range USB Adapter	Model Name :	AWUS036NHR
Temperature :	20 °C	Relative Humidity :	48%
Pressure :	1010 hPa	Test Voltage :	DC5V from PC
Test Mode :	CH11 (802.11N Mode,20MHz)	Polarization :	Horizontal

Frequency (MHz)	Meter Reading (dBµV)	Factor (dB)	Emission Level (dBµV/m)	Limits (dBµV/m)	Margin (dB)	Detector Type
2483.5	18.31	33.27	51.58	74.00	-22.42	peak
2483.5	12.31	33.27	45.58	54.00	-8.42	AVG
4924.00	6.12	44.10	50.22	74.00	-23.78	peak
4924.00	-4.19	44.10	39.91	54.00	-14.09	AVG
7386.00	-2.12	48.31	46.19	74.00	-27.81	peak
7386.00	-9.77	48.31	38.54	54.00	-15.46	AVG

Remark:

- Factor = Antenna Factor + Cable Loss – Pre-amplifier.

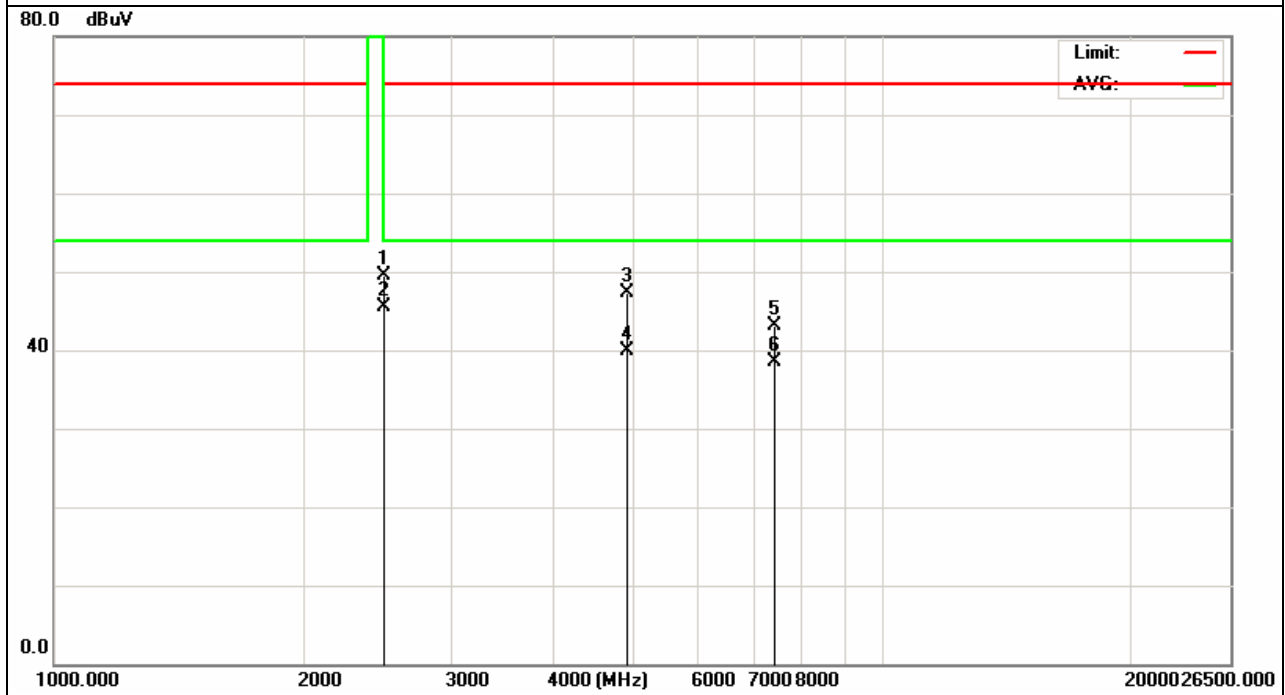

EUT :	IEEE 802.11b/g/n Long-Range USB Adapter	Model Name :	AWUS036NHR
Temperature :	20 °C	Relative Humidity :	48%
Pressure :	1010 hPa	Test Voltage :	DC 5V from PC
Test Mode :	CH11(802.11N Mode,20MHz)	Polarization :	Vertical

Frequency (MHz)	Meter Reading (dBµV)	Factor (dB)	Emission Level (dBµV/m)	Limits (dBµV/m)	Margin (dB)	Detector Type
2483.50	24.43	36.27	54.70	74.00	-16.30	peak
2483.50	15.34	33.27	48.61	54.00	-5.39	AVG
4924.00	7.67	44.10	51.77	74.00	-22.23	peak
4924.00	0.12	44.10	44.22	54.00	-9.78	AVG
7386.00	0.21	48.31	48.10	74.00	-25.90	peak
7386.00	-8.13	48.31	40.18	54.00	-13.82	AVG

Remark:

- Factor = Antenna Factor + Cable Loss – Pre-amplifier.

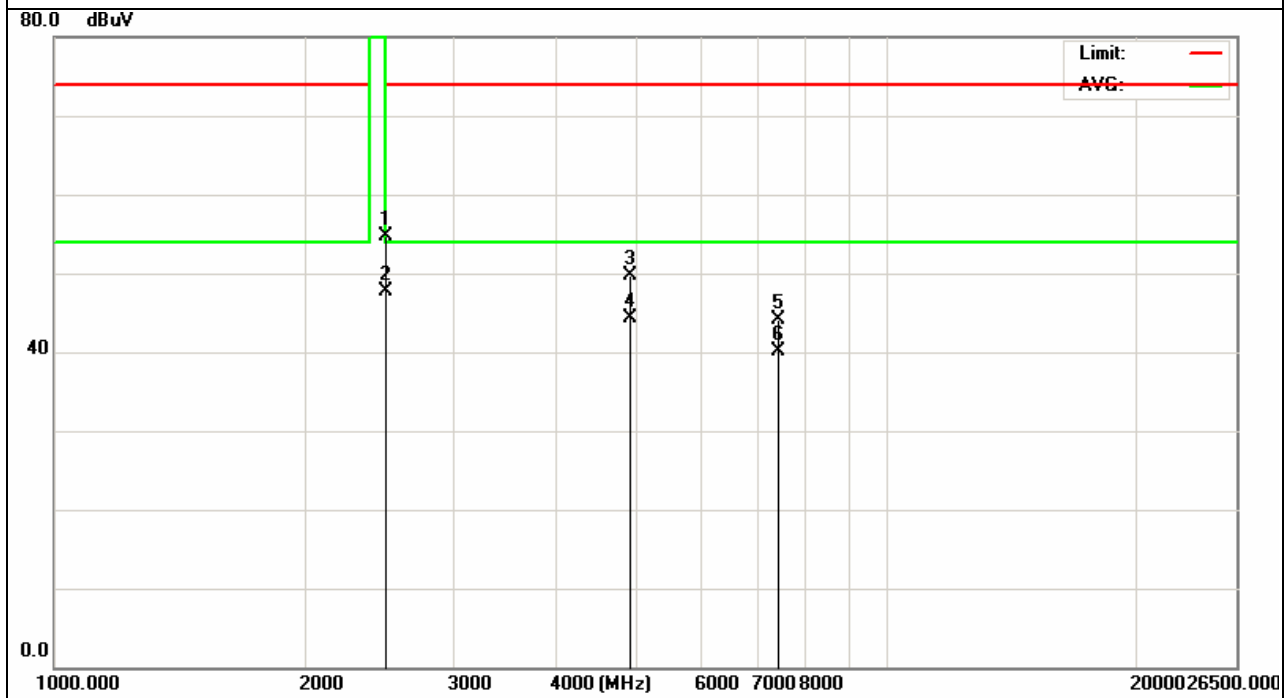



EUT :	IEEE 802.11b/g/n Long-Range USB Adapter	Model Name :	AWUS036NHR
Temperature :	20 °C	Relative Humidity :	48%
Pressure :	1010 hPa	Test Voltage :	DC 5V from PC
Test Mode :	CH3 (802.11N Mode,40MHz)	Polarization :	Horizontal

Frequency (MHz)	Meter Reading (dBμV)	Factor (dB)	Emission Level (dBμV/m)	Limits (dBμV/m)	Margin (dB)	Detector Type
2400.00	21.87	32.65	54.52	74.00	-19.48	peak
2400.00	15.21	32.65	47.86	54.00	-6.14	AVG
4844.00	4.11	44.04	48.15	74.00	-25.85	peak
4844.00	-2.60	44.04	41.44	54.00	-12.56	AVG
7266.00	-5.13	48.03	42.90	74.00	-31.10	peak
7266.00	-8.77	48.03	39.26	54.00	-14.74	AVG

Remark:

- Factor = Antenna Factor + Cable Loss – Pre-amplifier.

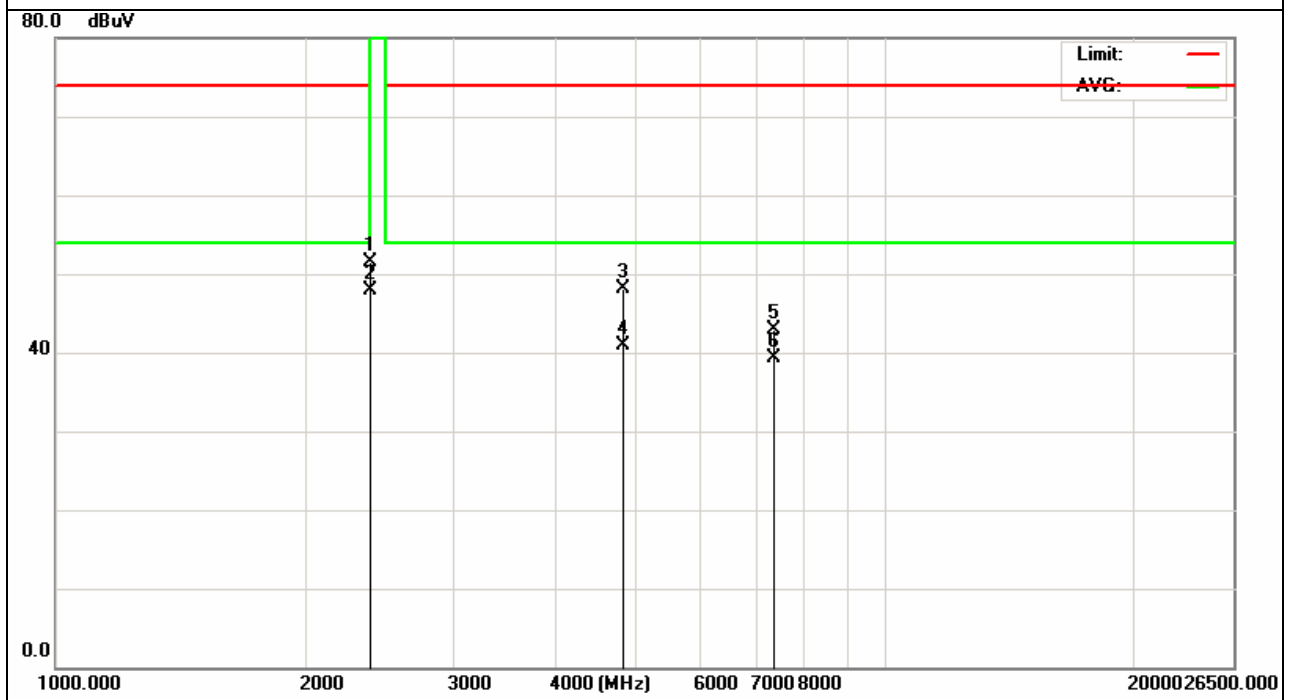

EUT :	IEEE 802.11b/g/n Long-Range USB Adapter	Model Name :	AWUS036NHR
Temperature :	20 °C	Relative Humidity :	48%
Pressure :	1010 hPa	Test Voltage :	DC 5V from PC
Test Mode :	CH3 (802.11N Mode,40MHz)	Polarization :	Vertical

Frequency (MHz)	Meter Reading (dBμV)	Factor (dB)	Emission Level (dBμV/m)	Limits (dBμV/m)	Margin (dB)	Detector Type
2400.00	19.99	32.65	52.64	74.00	-21.36	peak
2400.00	15.98	32.65	48.63	54.00	-5.37	AVG
4844.00	4.96	44.04	49.00	74.00	-25.00	peak
4844.00	-3.10	44.04	40.90	54.00	-13.06	AVG
7266.00	-5.13	48.03	42.90	74.00	-31.10	peak
7266.00	-6.18	48.03	41.85	54.00	-12.15	AVG

Remark:

- Factor = Antenna Factor + Cable Loss – Pre-amplifier.

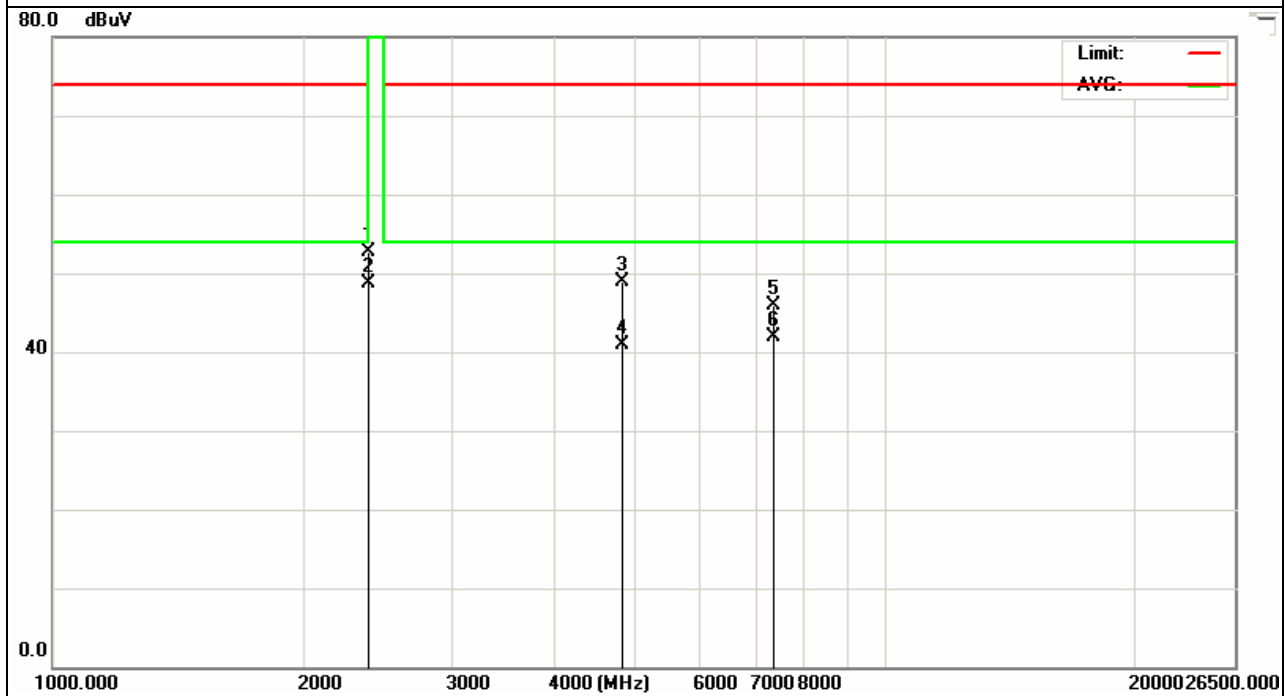

EUT :	IEEE 802.11b/g/n Long-Range USB Adapter	Model Name :	AWUS036NHR
Temperature :	20 °C	Relative Humidity :	48%
Pressure :	1010 hPa	Test Voltage :	DC 5V from PC
Test Mode :	CH6 (802.11N Mode,40MHz)	Polarization :	Horizontal

Frequency (MHz)	Meter Reading (dBµV)	Factor (dB)	Emission Level (dBµV/m)	Limits (dBµV/m)	Margin (dB)	Detector Type
4874.00	5.05	44.07	49.12	74.00	-24,88	peak
4874.00	-0.31	44.07	43.76	54.00	-10.24	AVG
7311.00	-3.11	47.97	44.86	74.00	-29.14	peak
7311.00	-9.16	47.97	38.81	54.00	-15.19	AVG

Remark:

2. Factor = Antenna Factor + Cable Loss – Pre-amplifier.

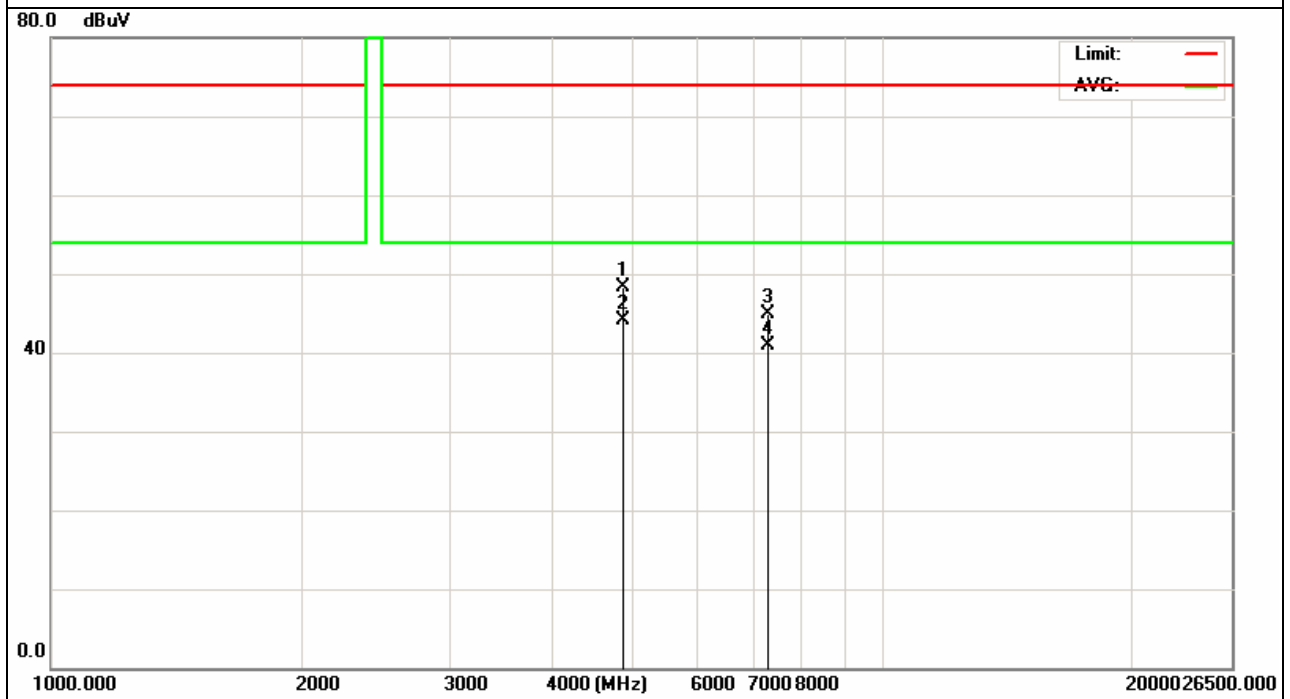

EUT :	IEEE 802.11b/g/n Long-Range USB Adapter	Model Name :	AWUS036NHR
Temperature :	20 °C	Relative Humidity :	48%
Pressure :	1010 hPa	Test Voltage :	DC 5V from PC
Test Mode :	CH6(802.11N Mode,40MHz)	Polarization :	Vertical

Frequency (MHz)	Meter Reading (dBµV)	Factor (dB)	Emission Level (dBµV/m)	Limits (dBµV/m)	Margin (dB)	Detector Type
4874.00	3.32	44.07	47.39	74.00	-26.61	peak
4874.00	-0.96	44.07	43.11	54.00	-10.89	AVG
7311.00	1.25	47.97	49.22	74.00	-24.78	peak
7311.00	-1.31	47.97	46.66	54.00	-7.34	AVG

Remark:

2. Factor = Antenna Factor + Cable Loss – Pre-amplifier.

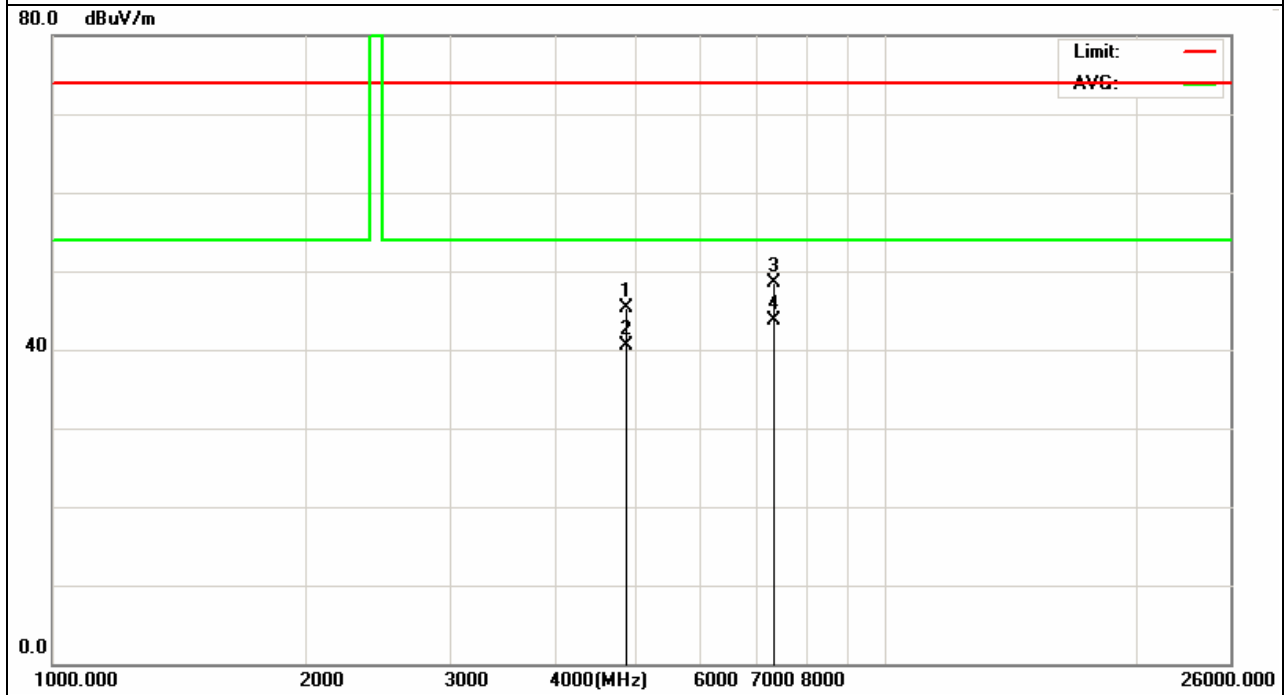

EUT :	IEEE 802.11b/g/n Long-Range USB Adapter	Model Name :	AWUS036NHR
Temperature :	20 °C	Relative Humidity :	48%
Pressure :	1010 hPa	Test Voltage :	DC 5V from PC
Test Mode :	CH9 (802.11N Mode,40MHz)	Polarization :	Horizontal

Frequency (MHz)	Meter Reading (dBµV)	Factor (dB)	Emission Level (dBµV/m)	Limits (dBµV/m)	Margin (dB)	Detector Type
2483.5	18.28	33.27	51.55	74.00	-22.45	peak
2483.5	11.34	33.27	44.61	54.00	-9.39	AVG
4904.00	-1.13	44.09	42.96	74.00	-31.04	peak
4904.00	-6.88	44.09	37.21	54.00	-16.79	AVG

Remark:

- Factor = Antenna Factor + Cable Loss – Pre-amplifier.

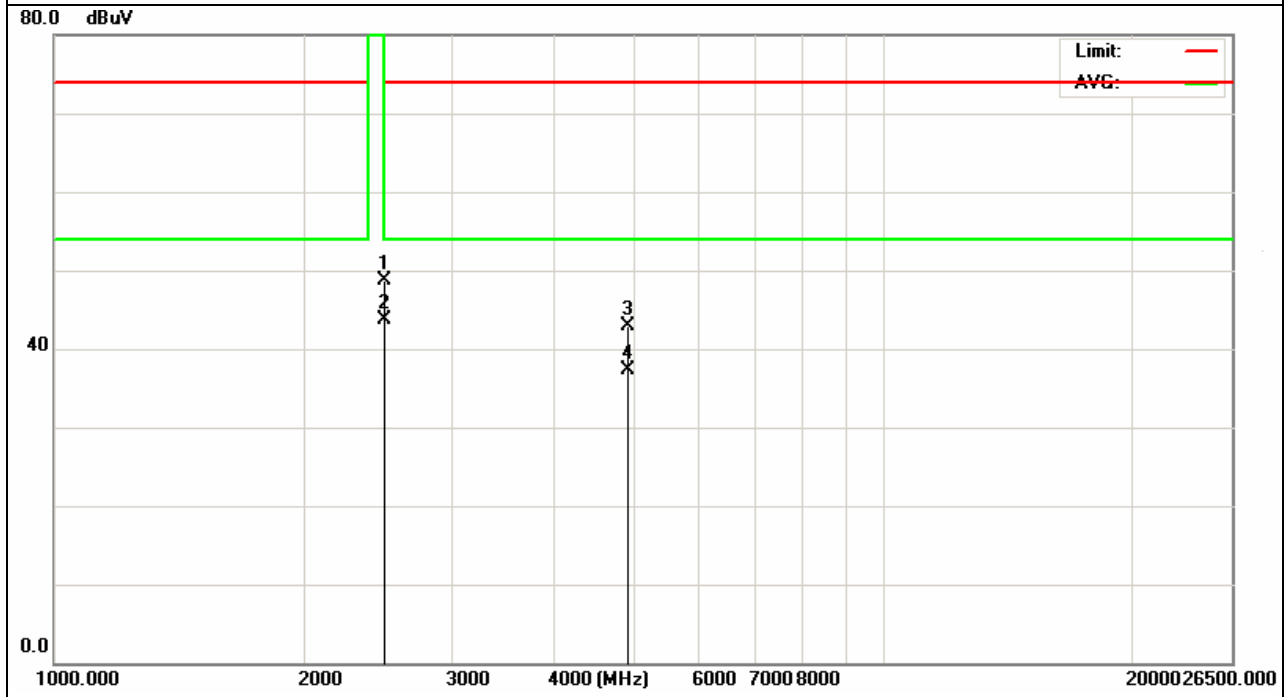

EUT :	IEEE 802.11b/g/n Long-Range USB Adapter	Model Name :	AWUS036NHR
Temperature :	20 °C	Relative Humidity :	48%
Pressure :	1010 hPa	Test Voltage :	DC 5V from PC
Test Mode :	CH9(802.11N Mode,40MHz)	Polarization :	Vertical

Frequency (MHz)	Meter Reading (dBµV)	Factor (dB)	Emission Level (dBµV/m)	Limits (dBµV/m)	Margin (dB)	Detector Type
2483.5	15.11	33.27	48.38	74.00	-25.62	peak
2483.5	8.81	33.27	42.08	54.00	-11.92	AVG
4904.00	-5.87	44.09	38.22	74.00	-35.78	peak
4904.00	-5.38	44.09	38.71	54.00	-15.29	AVG

Remark:

- Factor = Antenna Factor + Cable Loss – Pre-amplifier.

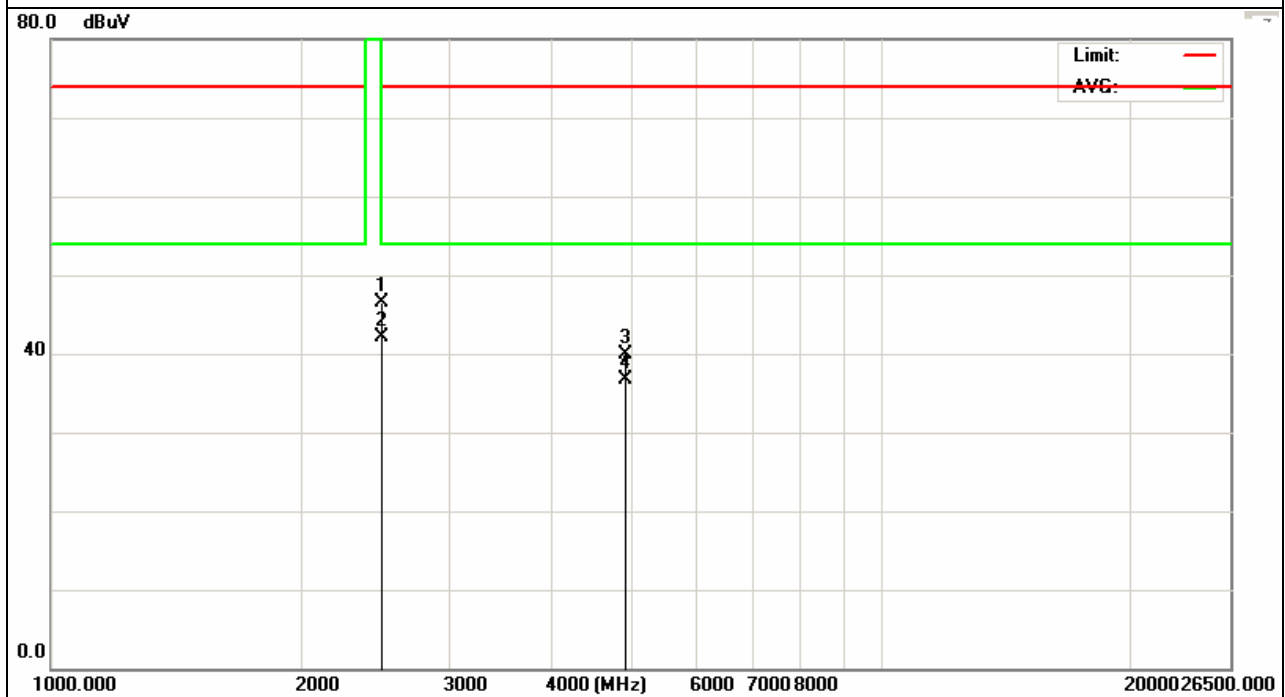

#### 4. POWER SPECTRAL DENSITY TEST

##### 4.1 APPLIED PROCEDURES / LIMIT

FCC Part15 (15.247) , Subpart C				
Section	Test Item	Limit	Frequency Range (MHz)	Result
15.247 (d) & A8.2	Power Spectral Density	8 dBm (in any 3KHz)	2400-2483.5	PASS

Spectrum Parameters	Setting
Attenuation	Auto
Span Frequency	> Operating Frequency Range
RB	3 kHz
VB	30 kHz
Detector	Peak
Trace	Max Hold
Sweep Time	500s

##### 4.1.1 TEST PROCEDURE

- a. The EUT was directly connected to the spectrum analyzer and antenna output port as show in the block diagram below,
- b. Spectrum Setting : RBW= 3KHz, VBW=30KHz, Sweep time = 500s.

##### 4.1.2 DEVIATION FROM STANDARD

No deviation.

##### 4.1.3 TEST SETUP



##### 4.1.4 EUT OPERATION CONDITIONS

The EUT tested system was configured as the statements of 4.1.6 Unless otherwise a special operating condition is specified in the follows during the testing.

### 4.1.5 TEST RESULTS

EUT :	IEEE 802.11b/g/n Long-Range USB Adapter	Model Name :	AWUS036NHR
Temperature :	25 °C	Relative Humidity :	60%
Pressure :	1015 hPa	Test Voltage :	DC 5V from PC
Test Mode :	TX B MODE /CH01, CH06, CH11		

Frequency	Power Density (dBm)	Limit (dBm)	Result
2412 MHz	6.516	8	<b>PASS</b>
2437 MHz	6.161	8	<b>PASS</b>
2462 MHz	5.936	8	<b>PASS</b>

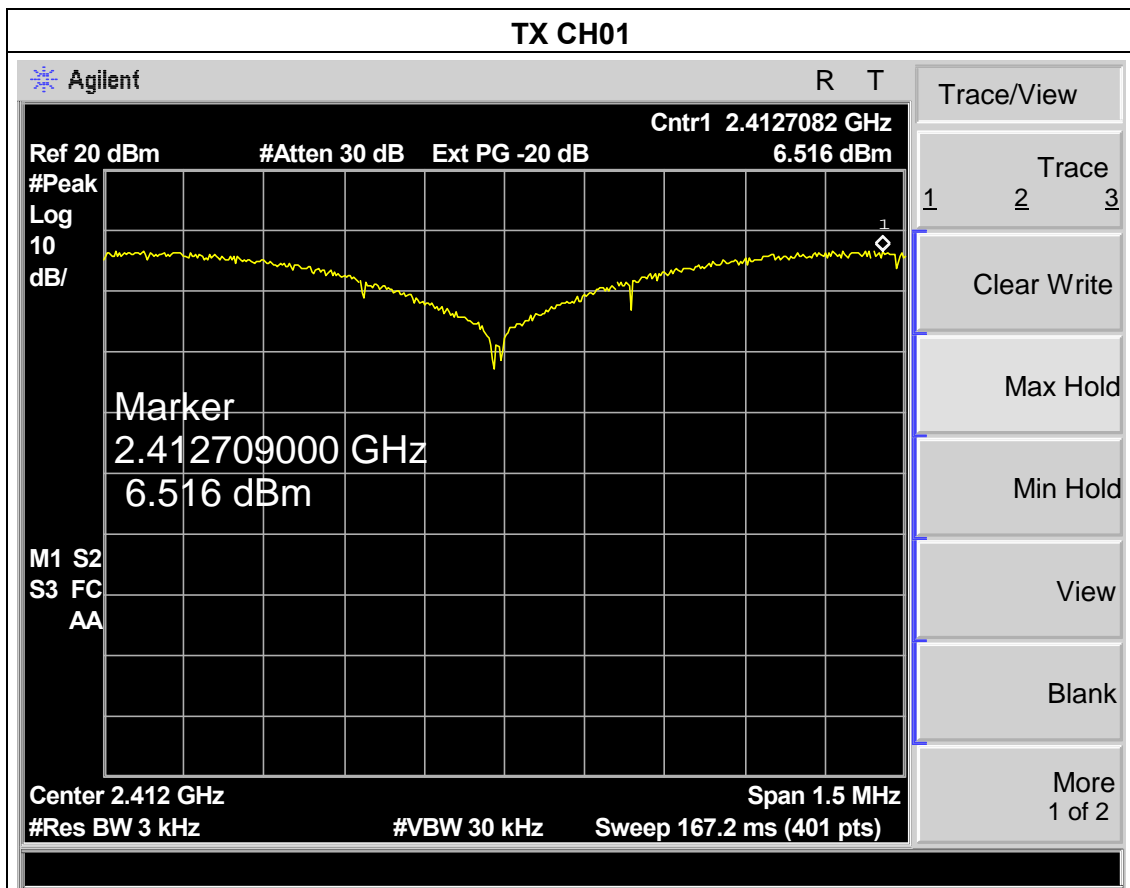



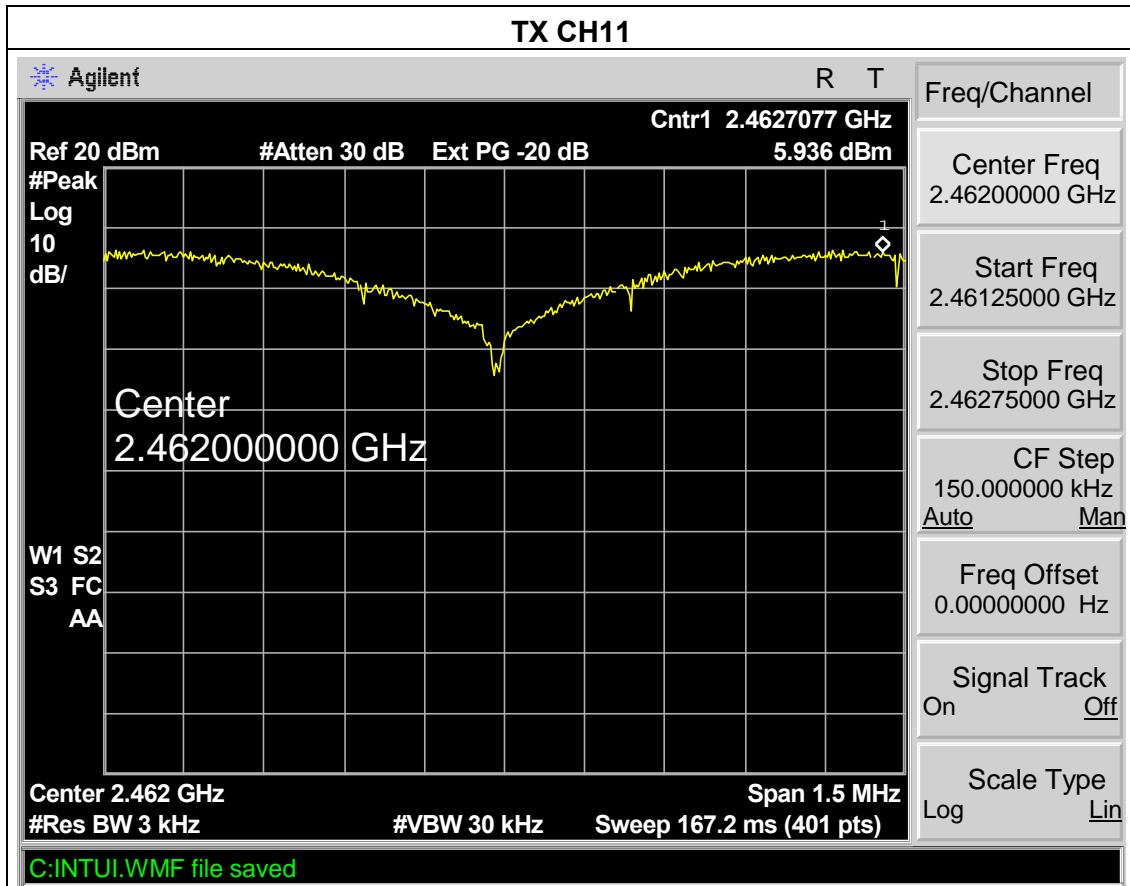
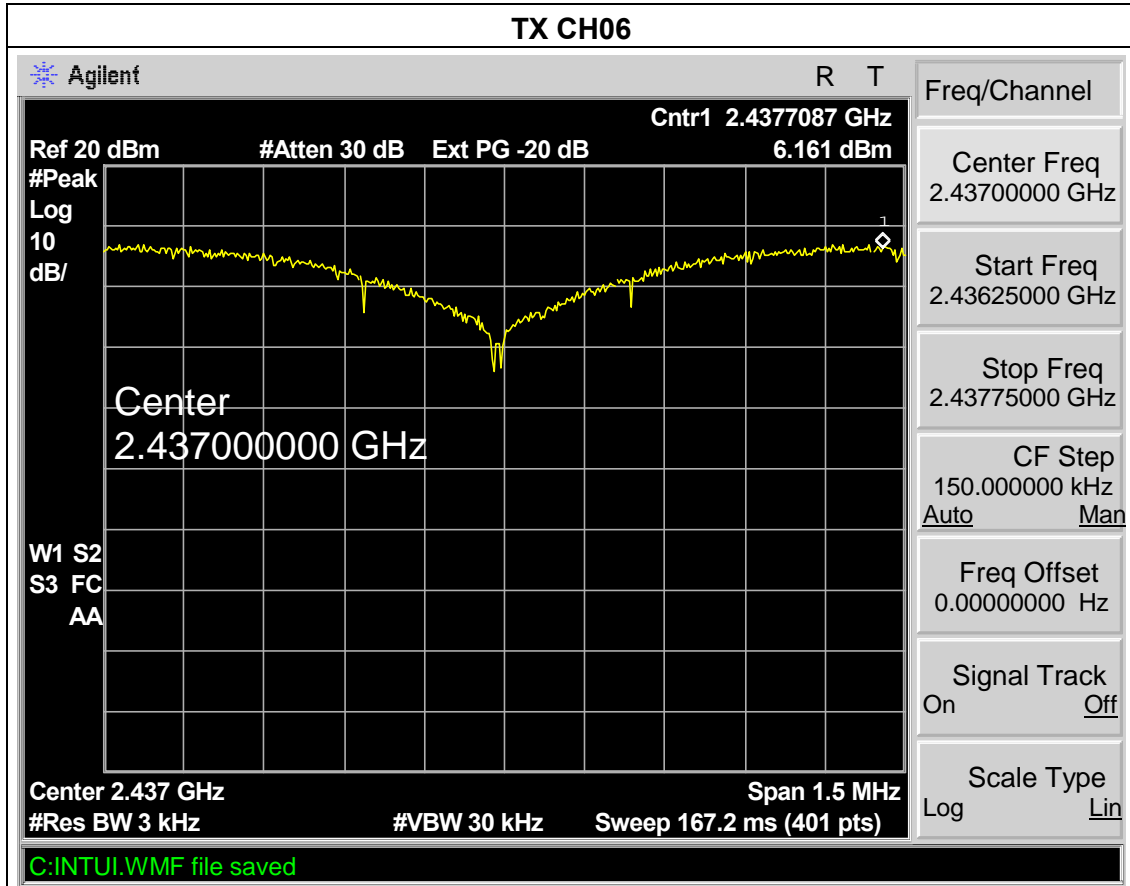

EUT :	IEEE 802.11b/g/n Long-Range USB Adapter	Model Name :	AWUS036NHR
Temperature :	25 °C	Relative Humidity :	60%
Pressure :	1015 hPa	Test Voltage :	DC 5V from PC
Test Mode :	TX G MODE /CH01, CH06, CH11		

Frequency	Power Density (dBm)	Limit (dBm)	Result
2412 MHz	5.182	8	<b>PASS</b>
2437MHz	5.346	8	<b>PASS</b>
2462 MHz	3.118	8	<b>PASS</b>

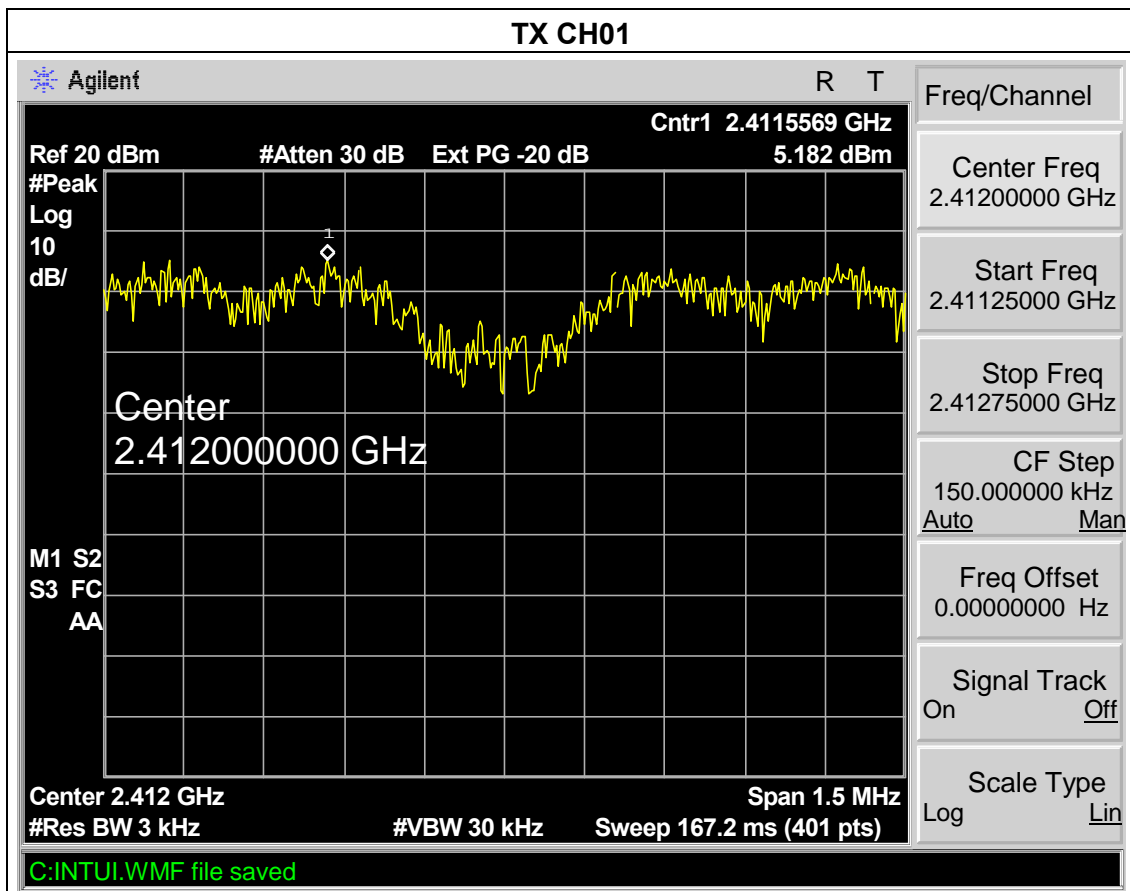

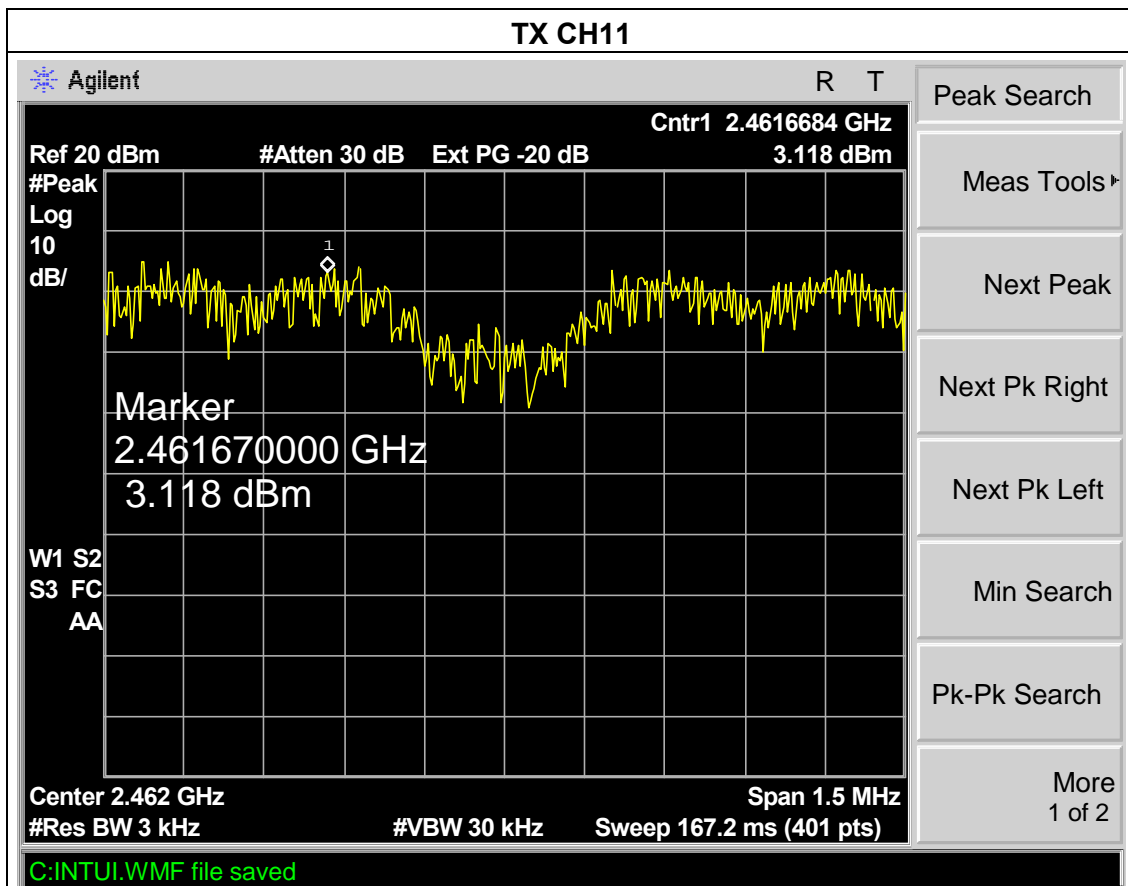
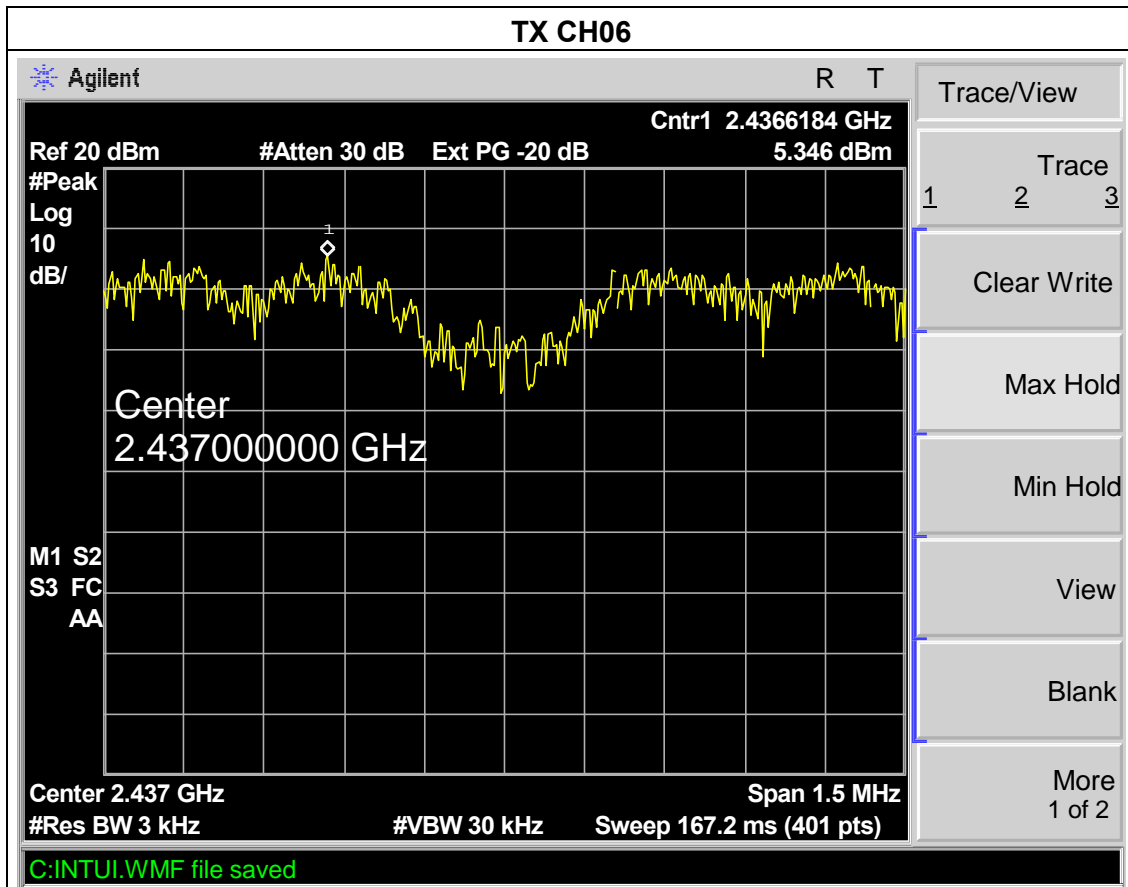

EUT :	IEEE 802.11b/g/n Long-Range USB Adapter	Model Name :	AWUS036NHR
Temperature :	25 °C	Relative Humidity :	60%
Pressure :	1015 hPa	Test Voltage :	DC5V from PC
Test Mode :	TX N MODE /CH01, CH06, CH11, 20MHz		

Frequency	Power Density (dBm)	Limit (dBm)	Result
2412 MHz	3.063	8	<b>PASS</b>
2437MHz	3.302	8	<b>PASS</b>
2462 MHz	4.317	8	<b>PASS</b>

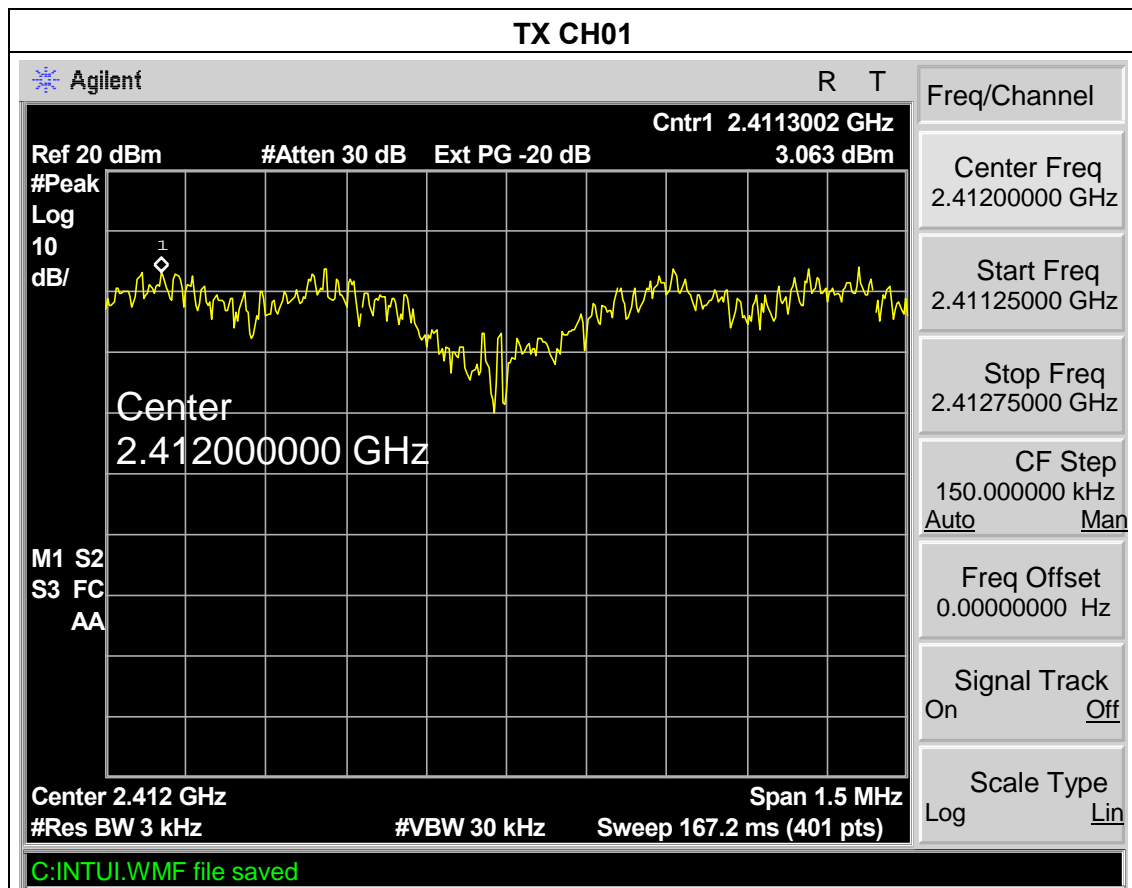

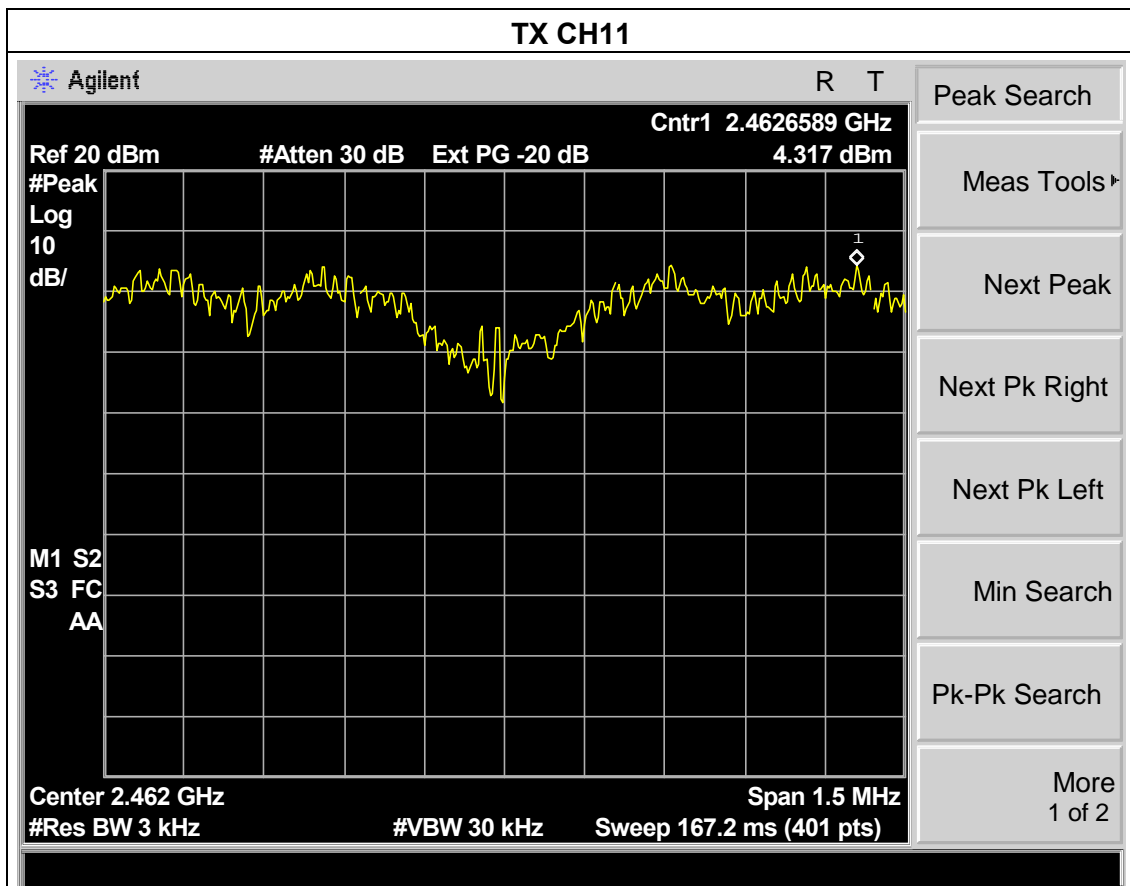
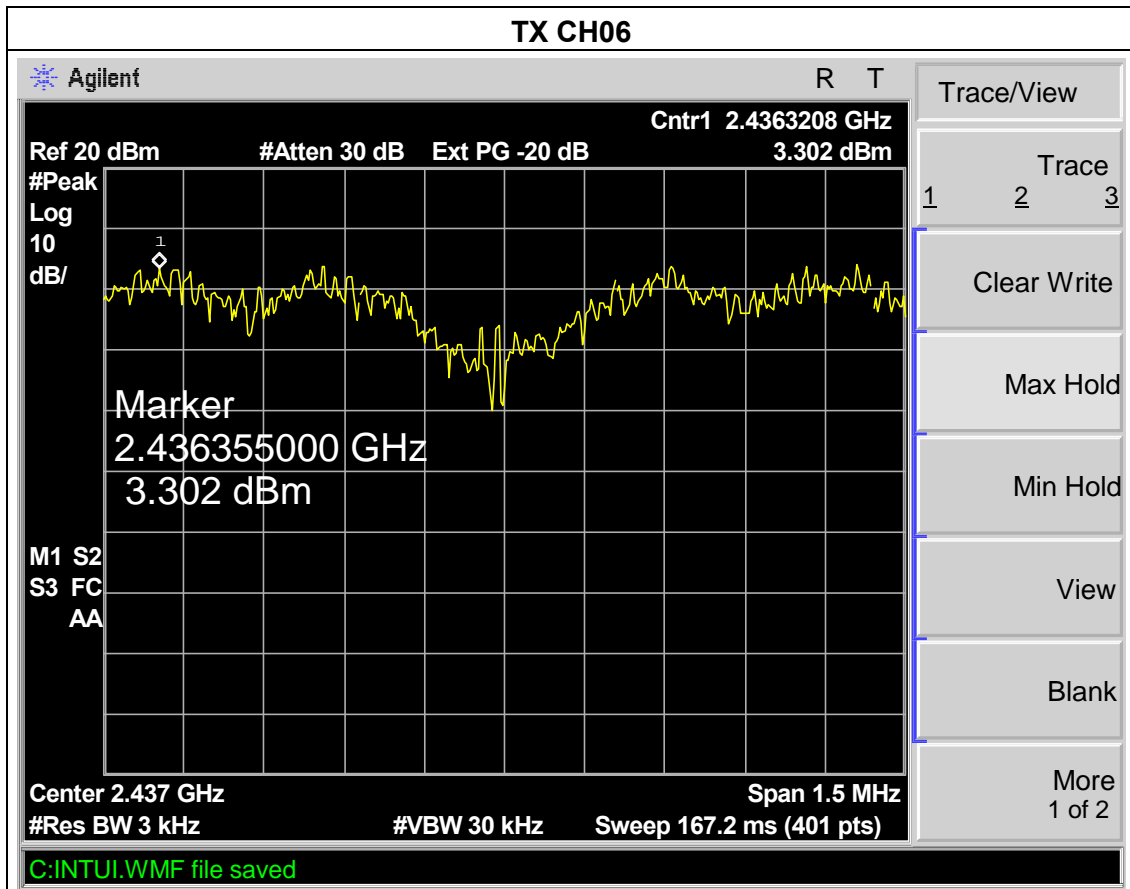

EUT :	IEEE 802.11b/g/n Long-Range USB Adapter	Model Name :	AWUS036NHR
Temperature :	25 °C	Relative Humidity :	60%
Pressure :	1015 hPa	Test Voltage :	DC5V from PC
Test Mode :	TX N MODE CH03/CH06/CH09, 40MHz		

Frequency	Power Density (dBm)	Limit (dBm)	Result
2422 MHz	2.992	8	<b>PASS</b>
2437 MHz	2.278	8	<b>PASS</b>
2452 MHz	5.974	8	<b>PASS</b>

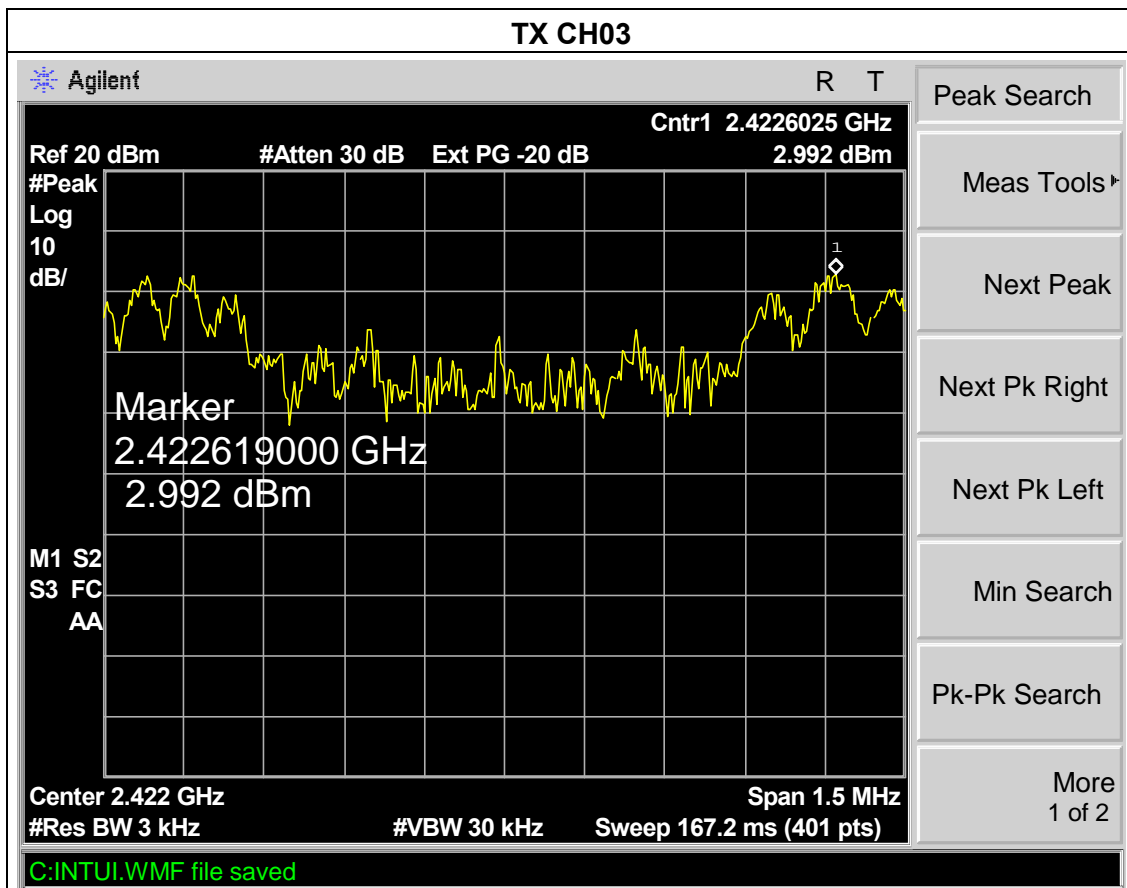

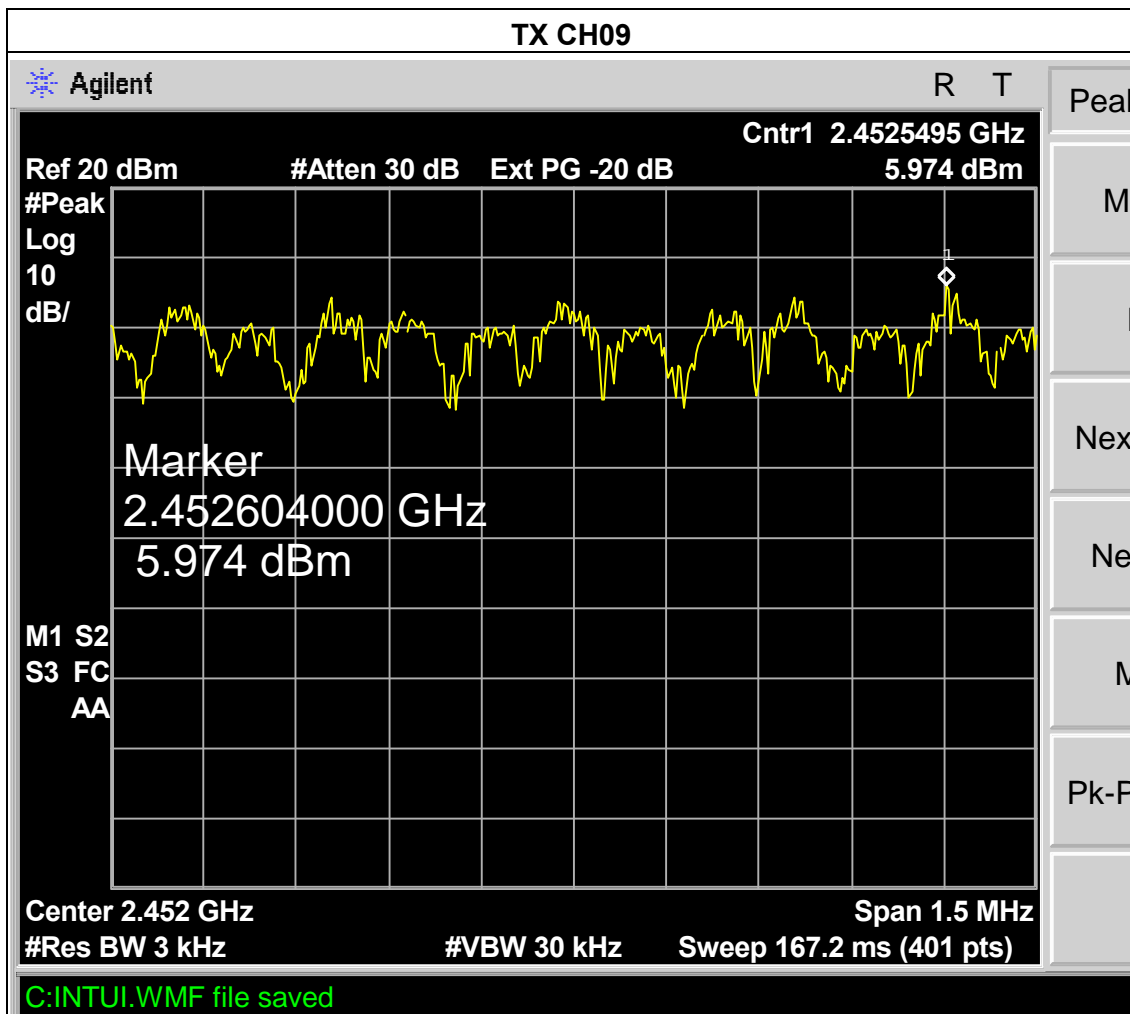
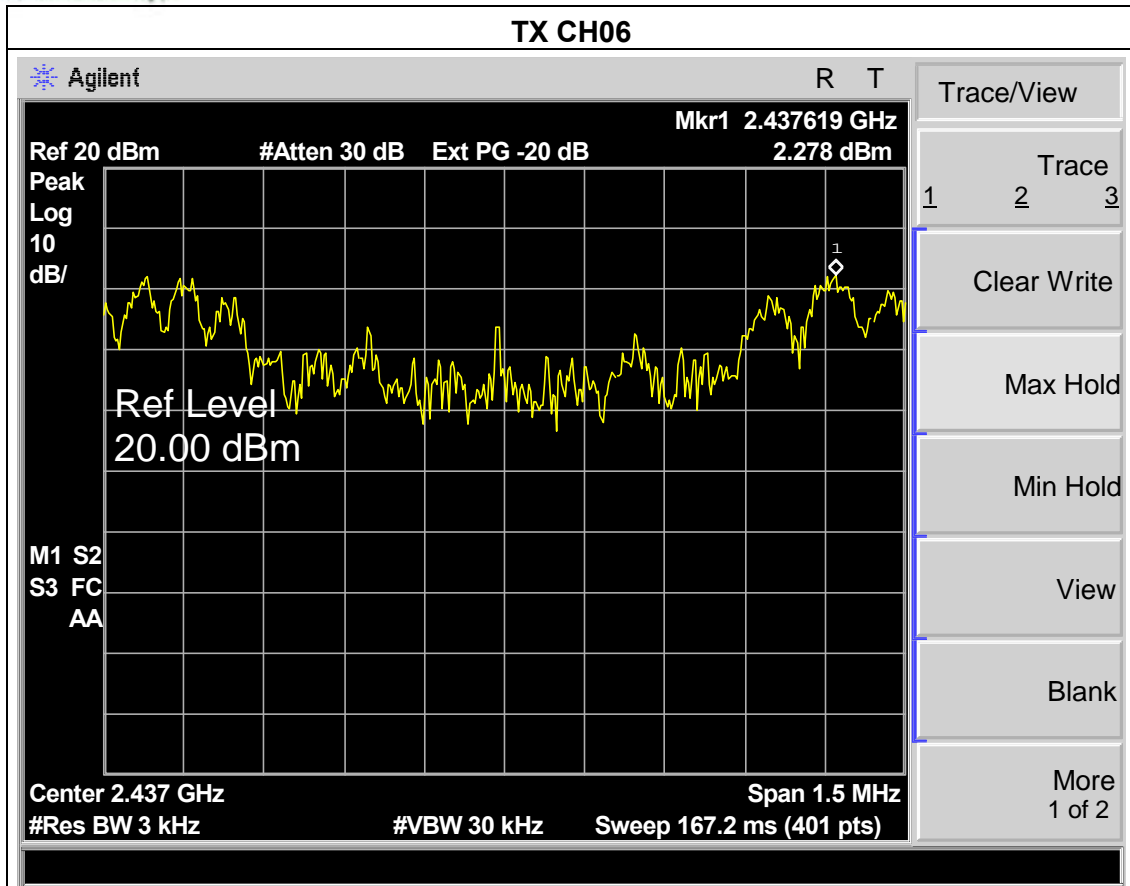

## 5. BANDWIDTH TEST

### 5.1 APPLIED PROCEDURES / LIMIT

FCC Part15 (15.247) , Subpart C & RSS-210 Annex 8				
Section	Test Item	Limit	Frequency Range (MHz)	Result
15.247 (a)(2)& A8.2	Bandwidth	$\geq 500\text{KHz}$ (6dB bandwidth)	2400-2483.5	PASS

Spectrum Parameter	Setting
Attenuation	Auto
Span Frequency	$>$ Measurement Bandwidth or Channel Separation
RB	30 kHz (20dB Bandwidth) / 100 kHz (Channel Separation)
VB	100 kHz (20dB Bandwidth) / 300 kHz (Channel Separation)
Detector	Peak
Trace	Max Hold
Sweep Time	Auto

#### 5.1.1 TEST PROCEDURE

- a. The EUT was directly connected to the spectrum analyzer and antenna output port as show in the block diagram below,
- b. Spectrum Setting : RBW= 100KHz, VBW=100KHz, Sweep time = Auto.

#### 5.1.2 DEVIATION FROM STANDARD

No deviation.

#### 5.1.3 TEST SETUP

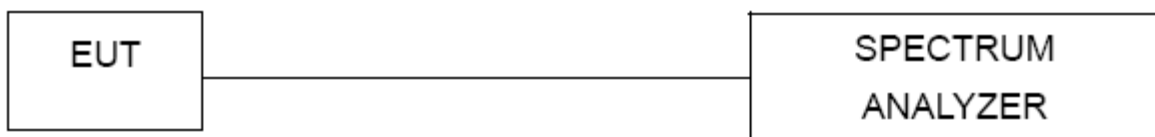

#### 5.1.4 EUT OPERATION CONDITIONS

The EUT tested system was configured as the statements of 4.1.6 Unless otherwise a special operating condition is specified in the follows during the testing.



### 5.1.5 TEST RESULTS

EUT :	IEEE 802.11b/g/n Long-Range USB Adapter	Model Name :	AWUS036NHR
Temperature :	25 °C	Relative Humidity :	60%
Pressure :	1012 hPa	Test Voltage :	DC 5V from PC
Test Mode :	TX B MODE /CH01, CH06, CH11		

Frequency	6dB Bandwidth (MHz)	99% Occupied BW (MHz)	Channel Separation (MHz)	Result
2412 MHz	10.072	14.802	>=500KHz	<b>PASS</b>
2437 MHz	10.092	14.798	>=500KHz	<b>PASS</b>
2462 MHz	10.037	14.803	>=500KHz	<b>PASS</b>

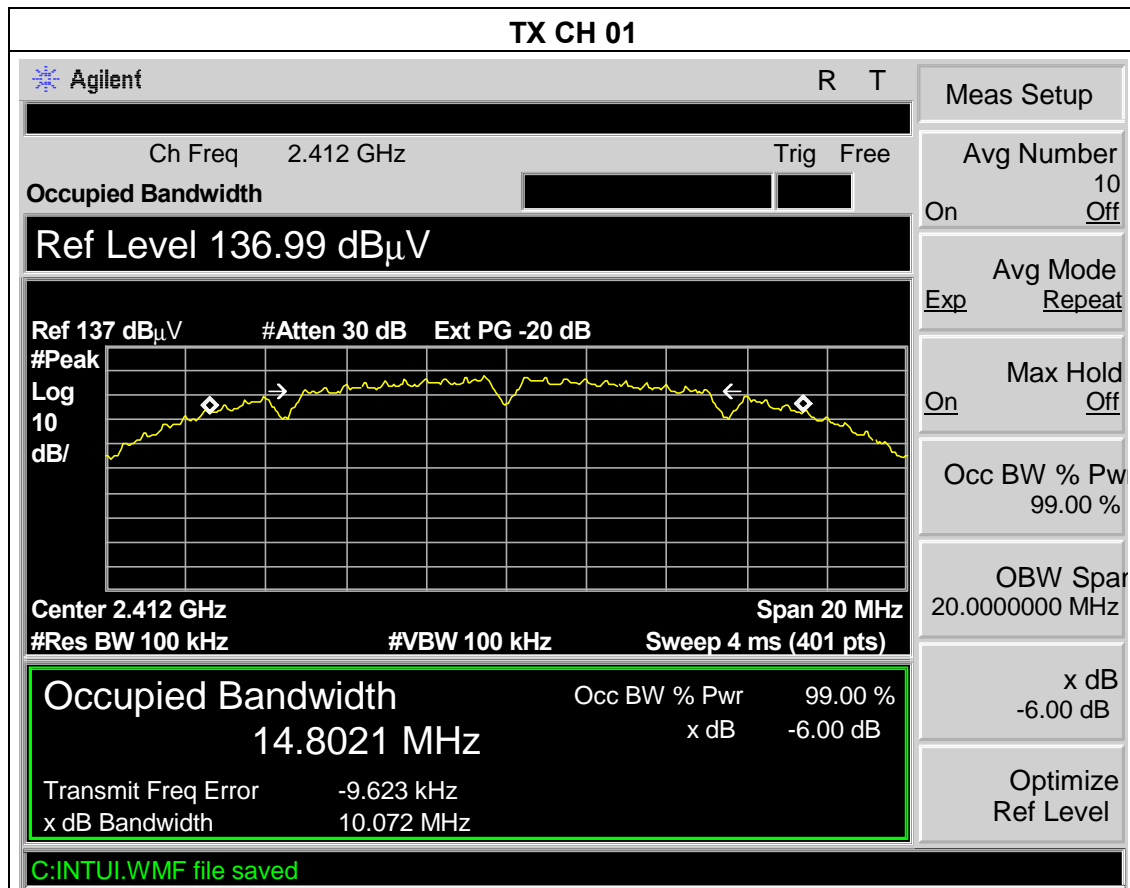

### TX CH 06

Agilent
R T

---

Ch Freq 2.437 GHz
Trig Free

Occupied Bandwidth                                          

## Center 2.43700000 GHz

Ref 137 dB<sub>μ</sub>V
#Atten 30 dB
Ext PG -20 dB

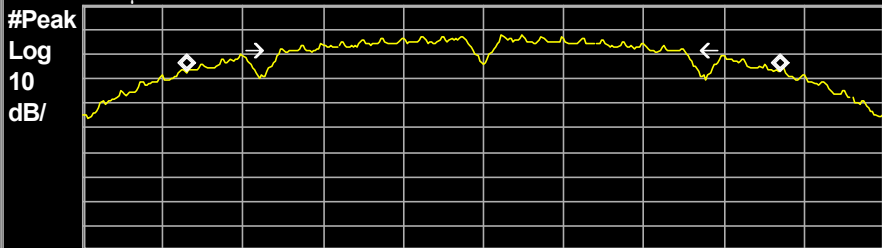

Center 2.437 GHz
Span 20 MHz

#Res BW 100 kHz
#VBW 100 kHz
Sweep 4 ms (401 pts)

<b>Occupied Bandwidth</b>	Occ BW % Pwr	99.00 %
<b>14.7983 MHz</b>	x dB	-6.00 dB
Transmit Freq Error	-8.363 kHz	
x dB Bandwidth	10.092 MHz	

C:INTUI.WMF file saved

Meas Setup	
Avg Number	10
	<input type="checkbox"/> On <input type="checkbox"/> Off
Avg Mode	Repeat
Exp	Repeat
Max Hold	Off
	<input type="checkbox"/> On <input type="checkbox"/> Off
Occ BW % Pwr	99.00 %
OBW Spar	20.0000000 MHz
x dB	-6.00 dB
Optimize	Ref Level

### TX CH 11

Agilent
R T

---

Ch Freq 2.462 GHz
Trig Free

Occupied Bandwidth                                          

## Center 2.46200000 GHz

Ref 137 dB<sub>μ</sub>V
#Atten 30 dB
Ext PG -20 dB

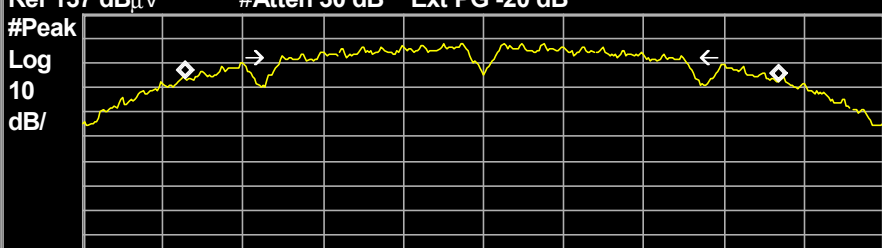

Center 2.462 GHz
Span 20 MHz

#Res BW 100 kHz
#VBW 100 kHz
Sweep 4 ms (401 pts)

<b>Occupied Bandwidth</b>	Occ BW % Pwr	99.00 %
<b>14.8035 MHz</b>	x dB	-6.00 dB
Transmit Freq Error	-40.181 kHz	
x dB Bandwidth	10.037 MHz	

C:INTUI.WMF file saved

Meas Setup	
Avg Number	10
	<input type="checkbox"/> On <input type="checkbox"/> Off
Avg Mode	Repeat
Exp	Repeat
Max Hold	Off
	<input type="checkbox"/> On <input type="checkbox"/> Off
Occ BW % Pwr	99.00 %
OBW Spar	20.0000000 MHz
x dB	-6.00 dB
Optimize	Ref Level

EUT :	IEEE 802.11b/g/n Long-Range USB Adapter	Model Name :	AWUS036NHR
Temperature :	25 °C	Relative Humidity :	60%
Pressure :	1012 hPa	Test Voltage :	DC 5v from PC
Test Mode :	TX G MODE /CH01, CH06, CH11		

Frequency	6dB Bandwidth (MHz)	99% Occupied BW (MHz)	Channel Separation (MHz)	Result
2412 MHz	16.502	16.369	>=500KHz	<b>PASS</b>
2437 MHz	16.518	16.391	>=500KHz	<b>PASS</b>
2462 MHz	16.537	16.407	>=500KHz	<b>PASS</b>

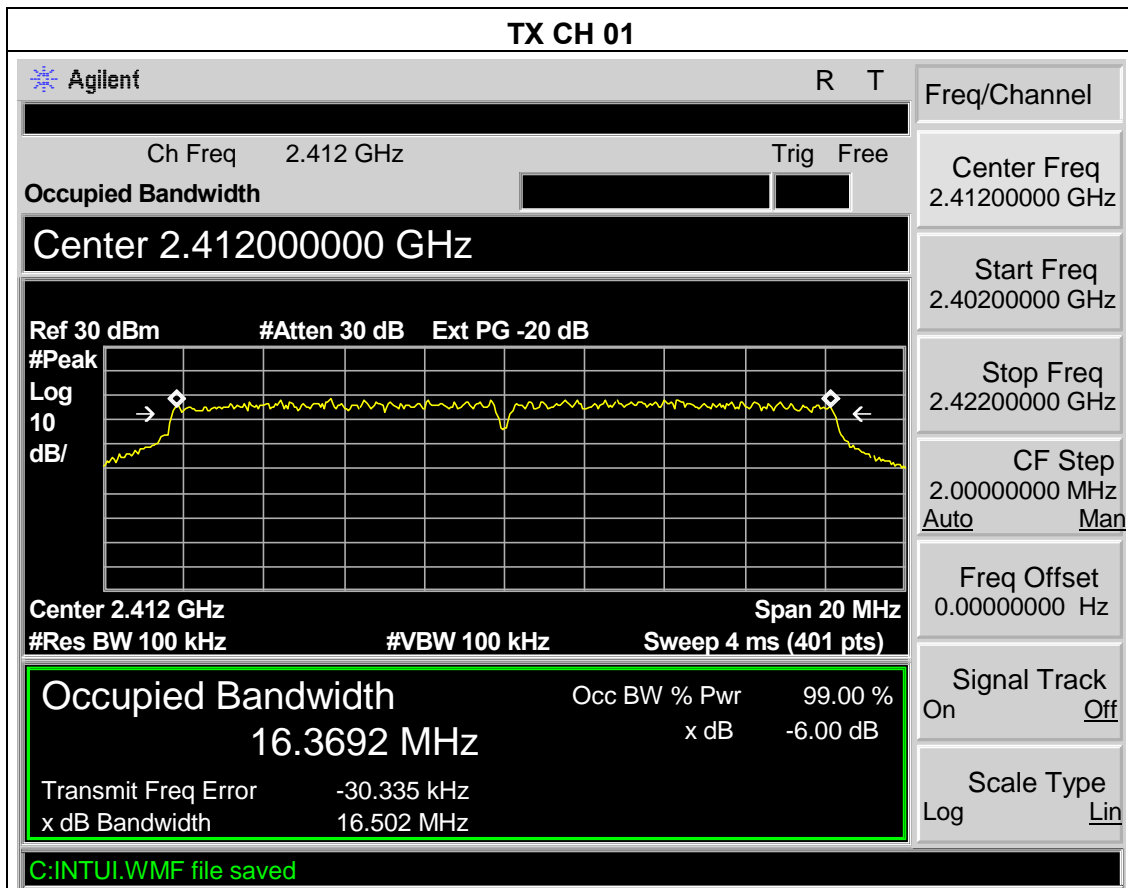

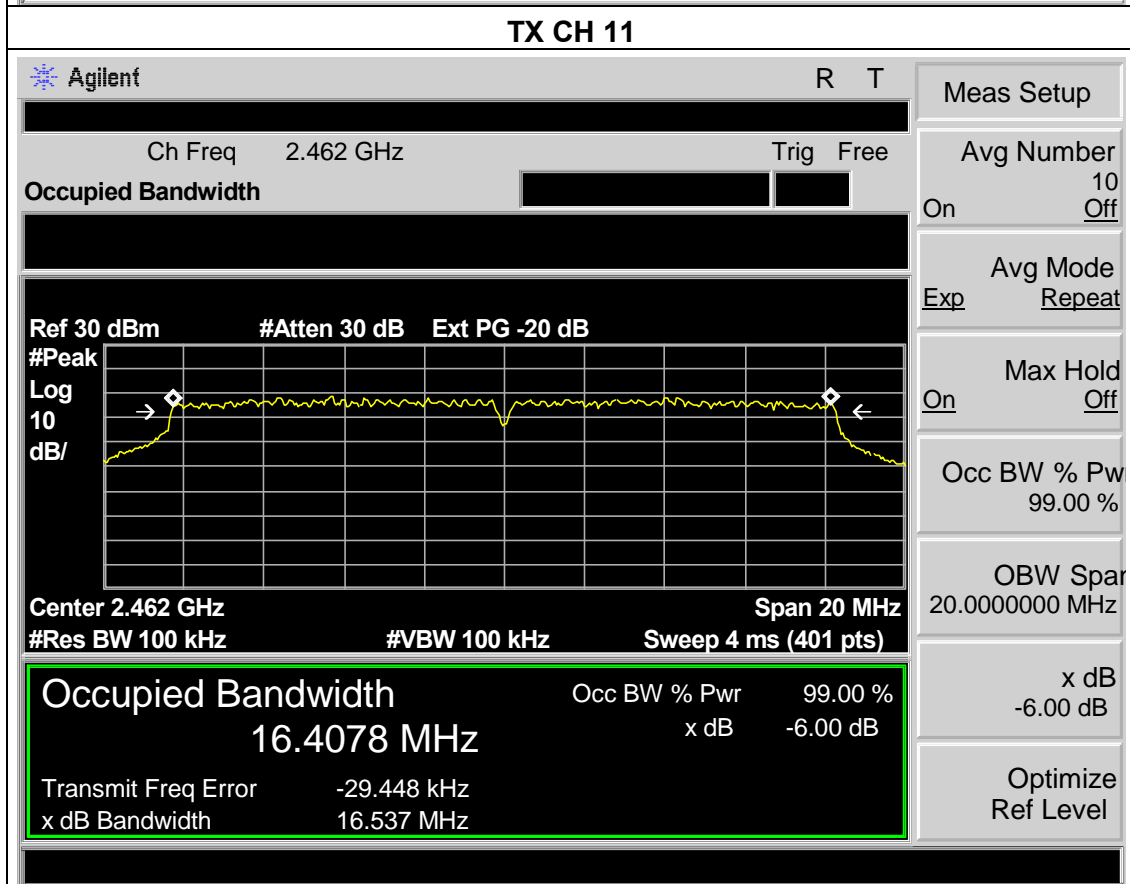
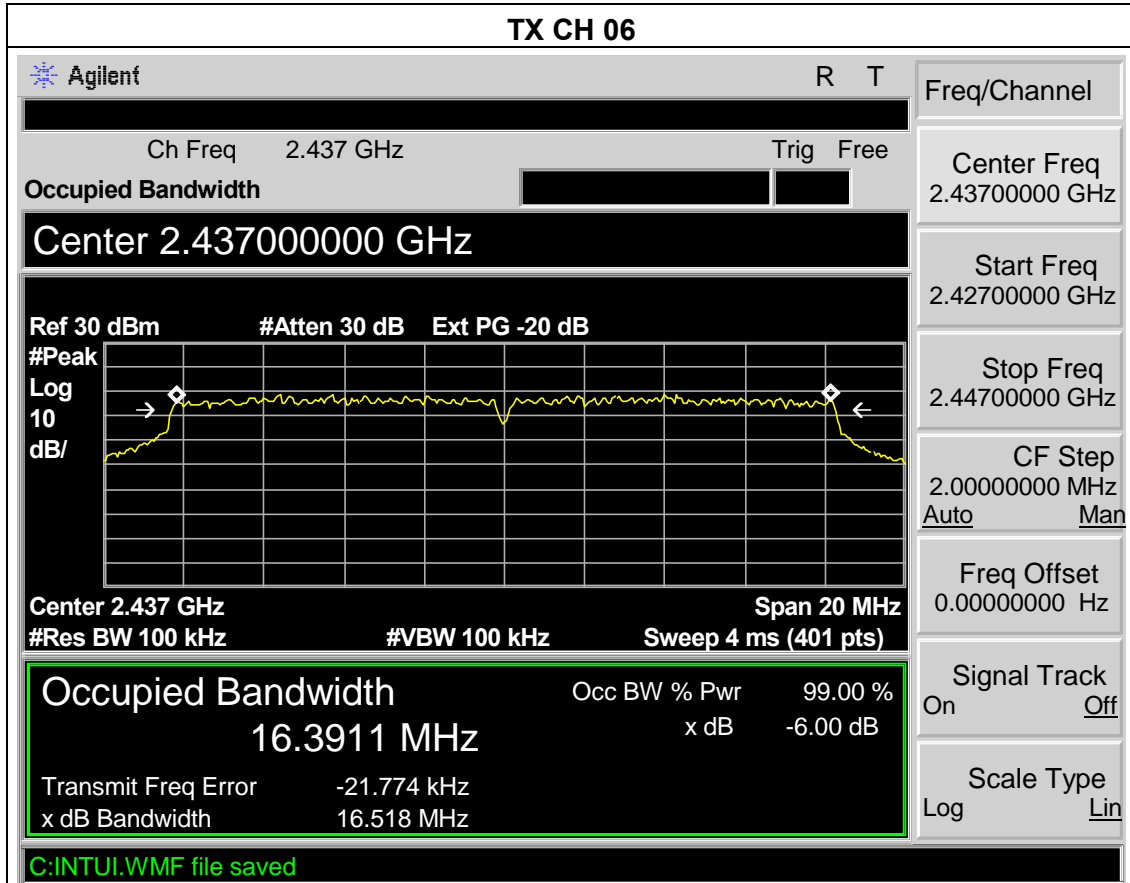

EUT :	IEEE 802.11b/g/n Long-Range USB Adapter	Model Name :	AWUS036NHR
Temperature :	25 °C	Relative Humidity :	60%
Pressure :	1012 hPa	Test Voltage :	DC 5V From PC
Test Mode :	TX N MODE /CH01, CH06, CH11(20MHz)		

Frequency	6dB Bandwidth (MHz)	99% Occupied BW (MHz)	Channel Separation (MHz)	Result
2412 MHz	17.770	17.557	>=500KHz	<b>PASS</b>
2437 MHz	17.752	17.585	>=500KHz	<b>PASS</b>
2462 MHz	17.768	17.583	>=500KHz	<b>PASS</b>

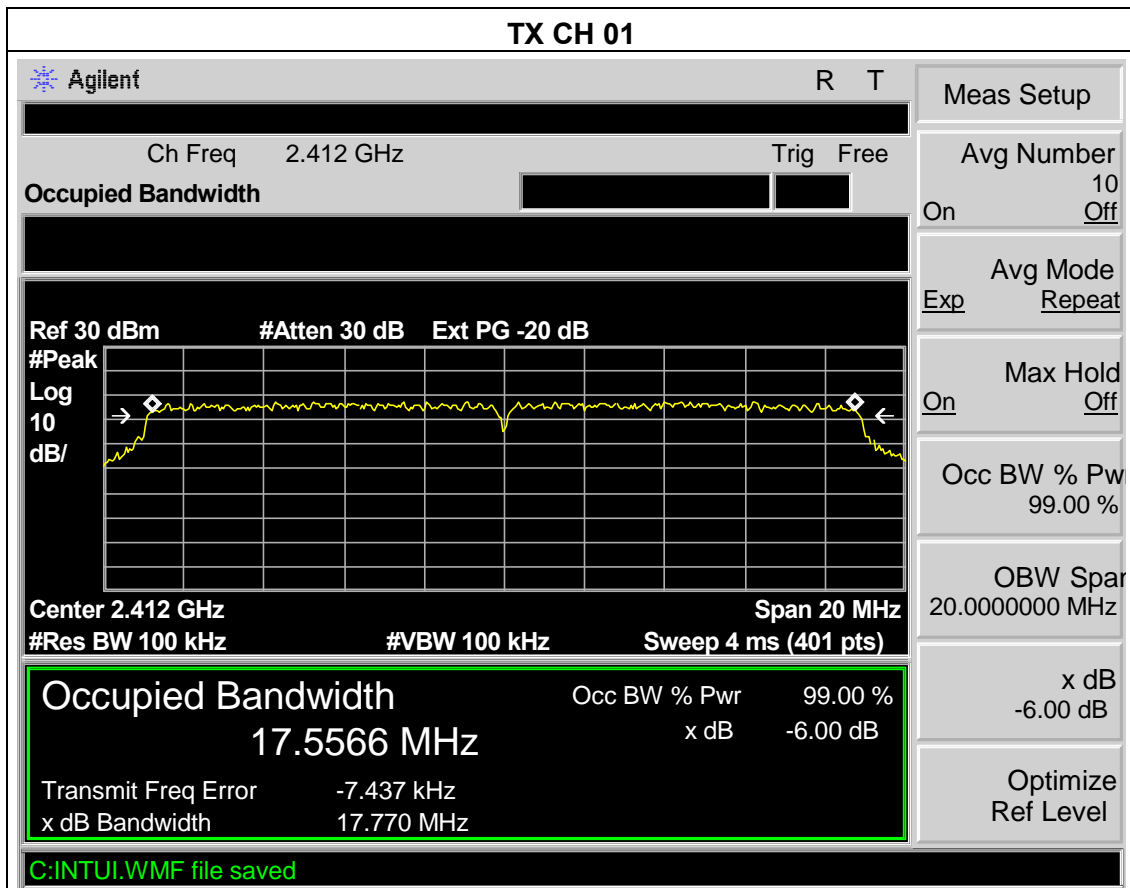

### TX CH 06

Agilent
R T

---

Ch Freq 2.437 GHz
Trig Free

Occupied Bandwidth

**Center 2.43700000 GHz**

Ref 30 dBm
#Atten 30 dB
Ext PG -20 dB

#Peak  
Log  
10  
dB/

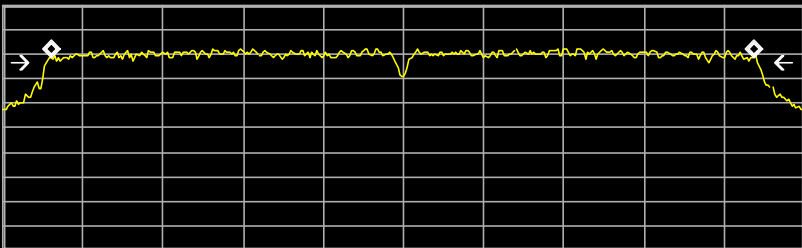

Center 2.437 GHz Span 20 MHz

#Res BW 100 kHz #VBW 100 kHz

Sweep 4 ms (401 pts)

<b>Occupied Bandwidth</b>	Occ BW % Pwr	99.00 %
<b>17.5854 MHz</b>	x dB	-6.00 dB
Transmit Freq Error	-20.813 kHz	
x dB Bandwidth	17.752 MHz	

Freq/Channel

Center Freq 2.43700000 GHz

Start Freq 2.42700000 GHz

Stop Freq 2.44700000 GHz

CF Step 2.00000000 MHz  
Auto Man

Freq Offset 0.00000000 Hz

Signal Track On Off

Scale Type Log Lin

C:INTUI.WMF file saved

### TX CH 11

Agilent
R T

---

Ch Freq 2.462 GHz
Trig Free

Occupied Bandwidth

**Center 2.46200000 GHz**

Ref 30 dBm
#Atten 30 dB
Ext PG -20 dB

#Peak  
Log  
10  
dB/

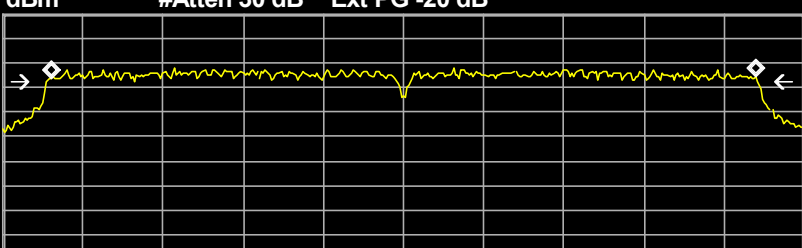

Center 2.462 GHz Span 20 MHz

#Res BW 100 kHz #VBW 100 kHz

Sweep 4 ms (401 pts)

<b>Occupied Bandwidth</b>	Occ BW % Pwr	99.00 %
<b>17.5828 MHz</b>	x dB	-6.00 dB
Transmit Freq Error	-16.099 kHz	
x dB Bandwidth	17.768 MHz	

Freq/Channel

Center Freq 2.46200000 GHz

Start Freq 2.45200000 GHz

Stop Freq 2.47200000 GHz

CF Step 2.00000000 MHz  
Auto Man

Freq Offset 0.00000000 Hz

Signal Track On Off

Scale Type Log Lin

C:INTUI.WMF file saved

EUT :	IEEE 802.11b/g/n Long-Range USB Adapter	Model Name :	AWUS036NHR
Temperature :	25 °C	Relative Humidity :	60%
Pressure :	1012 hPa	Test Voltage :	DC5v from PC
Test Mode :	TX N MODE CH03 /CH06/CH09(40MHz)		

Frequency	6dB Bandwidth (MHz)	99% Occupied BW (MHz)	Channel Separation (MHz)	Result
2422 MHz	36.407	35.957	>=500KHz	<b>PASS</b>
2437 MHz	36.366	35.912	>=500KHz	<b>PASS</b>
2452 MHz	36.414	35.940	>=500KHz	<b>PASS</b>

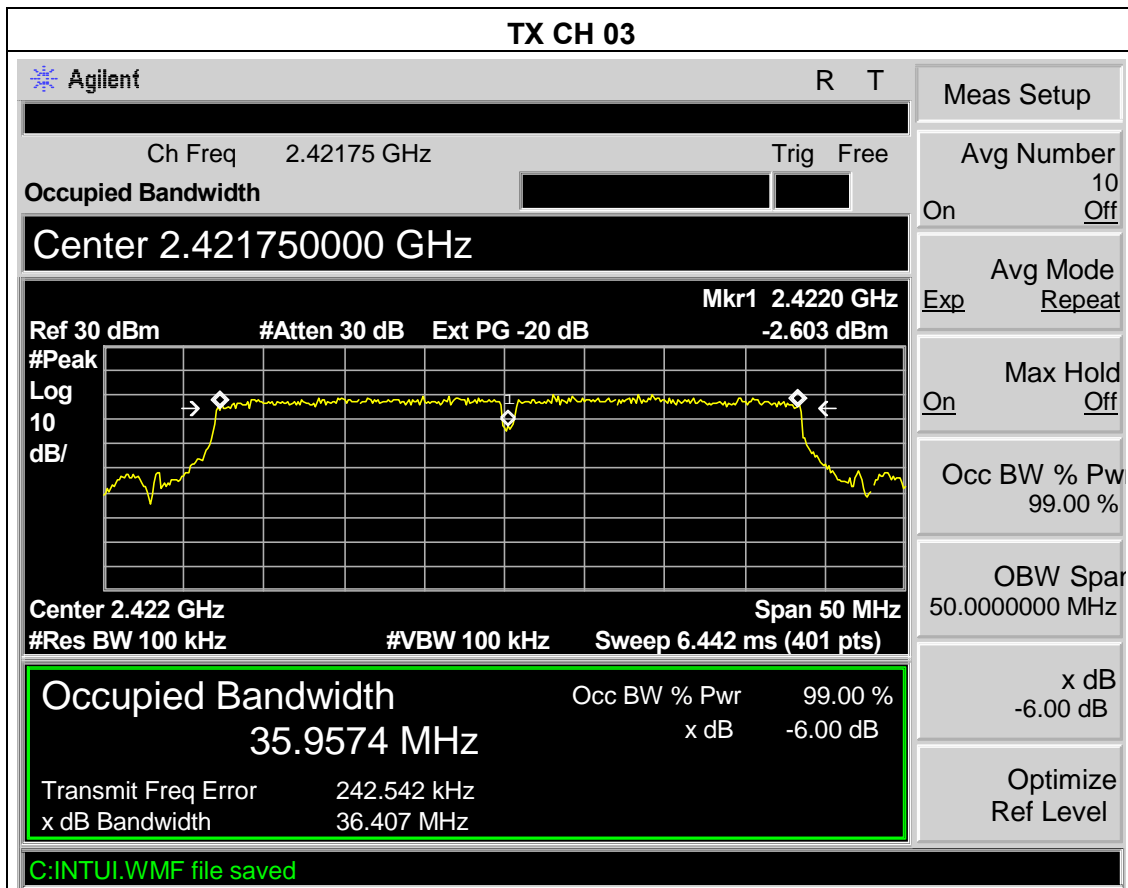

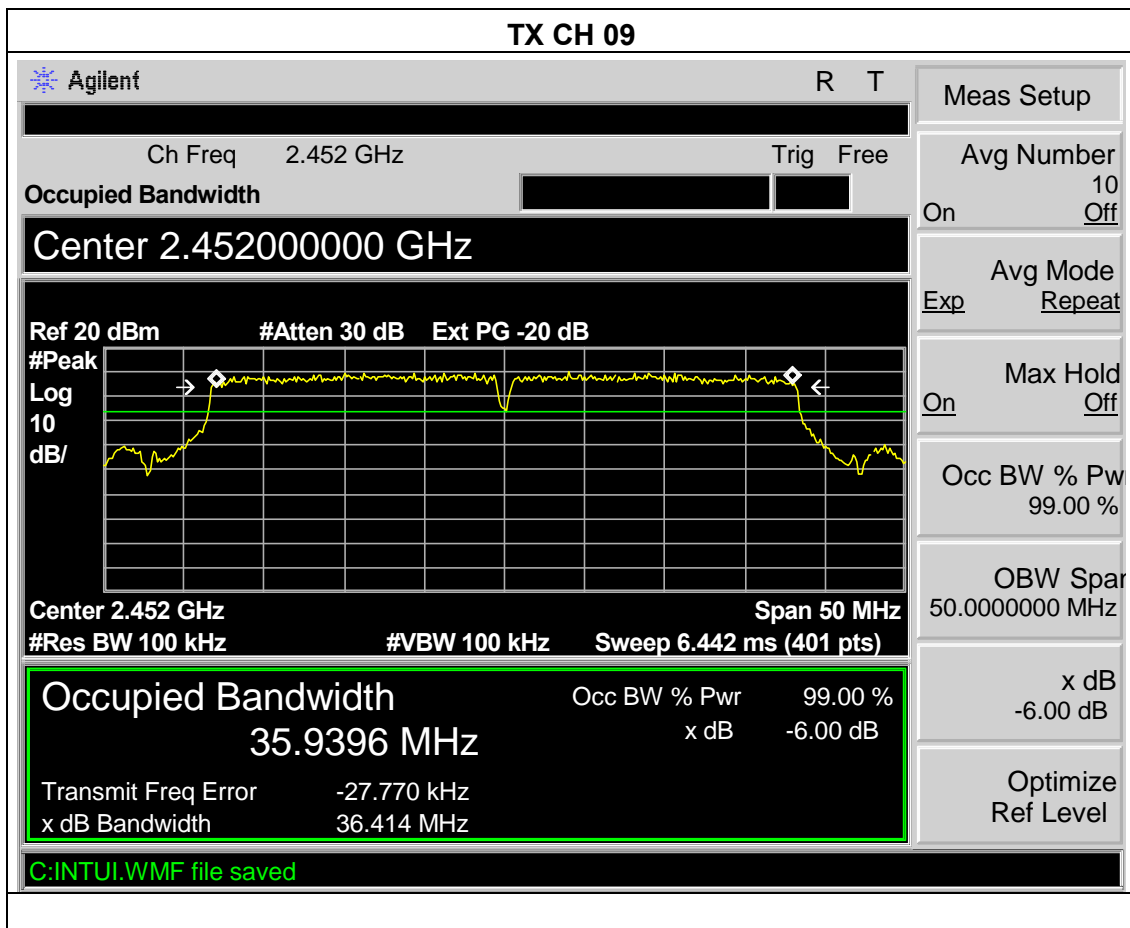
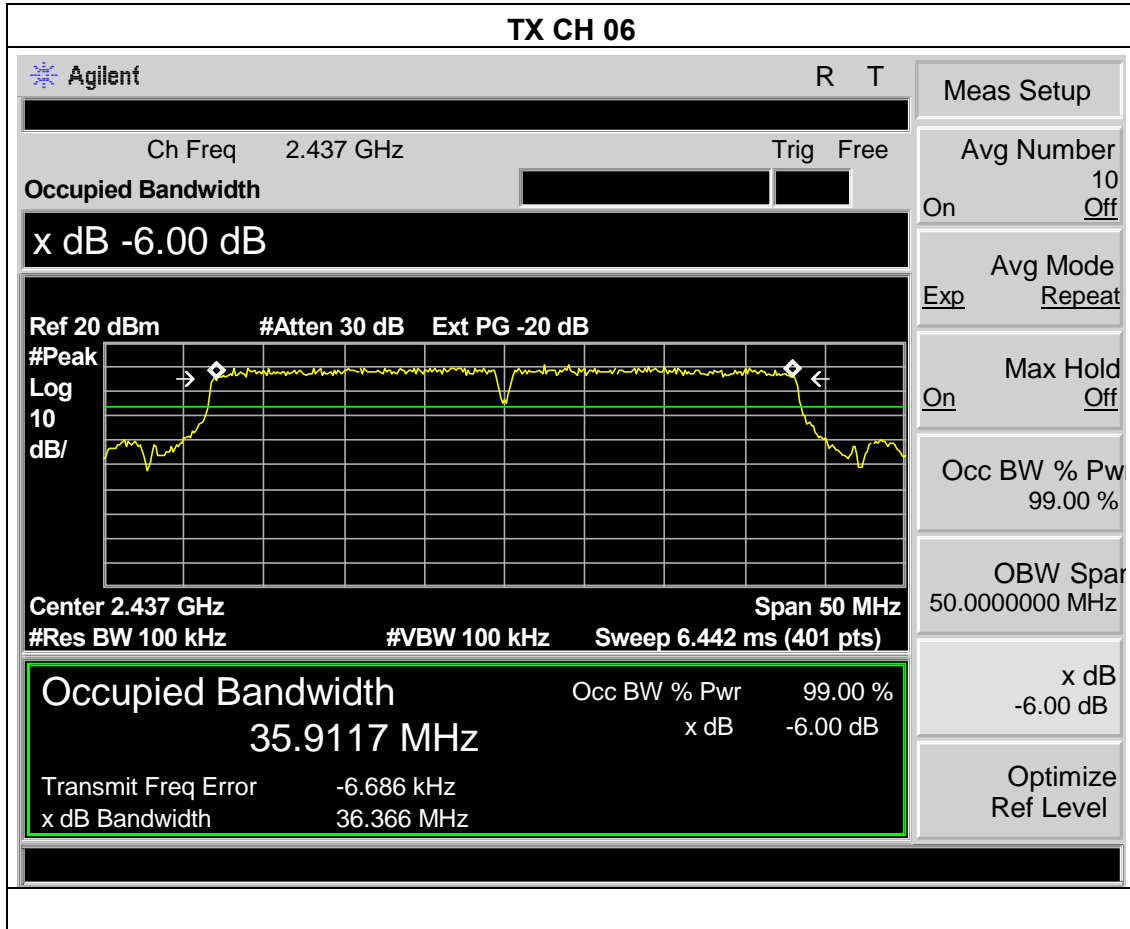



## 6. PEAK OUTPUT POWER TEST

### 6.1 APPLIED PROCEDURES / LIMIT

FCC Part15 (15.247) , Subpart C & RSS-210 Annex 8				
Section	Test Item	Limit	Frequency Range (MHz)	Result
15.247 (b)(1) & A8.4	Peak Output Power	1 watt or 30dBm	2400-2483.5	PASS

#### 6.1.1 TEST PROCEDURE

- a. The EUT was directly connected to the Power meter

#### 6.1.2 DEVIATION FROM STANDARD

No deviation.

#### 6.1.3 TEST SETUP



#### 6.1.4 EUT OPERATION CONDITIONS

The EUT tested system was configured as the statements of 4.1.6 Unless otherwise a special operating condition is specified in the follows during the testing.

**6.1.5 TEST RESULTS**

EUT :	IEEE 802.11b/g/n Long-Range USB Adapter	Model Name :	AWUS036NHR
Temperature :	25 °C	Relative Humidity :	60%
Pressure :	1012 hPa	Test Voltage :	DC5V from PC
Test Mode :	TX B MODE /CH01, CH06, CH11		

Test Channel	Frequency (MHz)	Peak output power (dBm)	LIMIT (dBm)	LIMIT (W)
CH01	2412	26.77	30	1
CH06	2437	26.57	30	1
CH11	2462	26.83	30	1

EUT :	IEEE 802.11b/g/n Long-Range USB Adapter	Model Name :	AWUS036NHR
Temperature :	25 °C	Relative Humidity :	60%
Pressure :	1012 hPa	Test Voltage :	DC5V from PC
Test Mode :	TX G MODE /CH01, CH06, CH11		

Test Channel	Frequency (MHz)	Peak output power (dBm)	LIMIT (dBm)	LIMIT (W)
CH01	2412	26.27	30	1
CH06	2437	26.16	30	1
CH11	2462	26.14	30	1

EUT :	IEEE 802.11b/g/n Long-Range USB Adapter	Model Name :	AWUS036NHR
Temperature :	25 °C	Relative Humidity :	60%
Pressure :	1012 hPa	Test Voltage :	DC5V from PC
Test Mode :	TX N MODE /CH01, CH06, CH11(20MHz)		

Test Channel	Frequency (MHz)	Peak output power (dBm)	LIMIT (dBm)	LIMIT (W)
CH01	2412	25.68	30	1
CH06	2437	25.49	30	1
CH11	2462	25.79	30	1

EUT :	IEEE 802.11b/g/n Long-Range USB Adapter	Model Name :	AWUS036NHR
Temperature :	25 °C	Relative Humidity :	60%
Pressure :	1012 hPa	Test Voltage :	DC5V from PC
Test Mode :	TX N MODE /CH03, CH06, CH09(40MHz)		

Test Channel	Frequency (MHz)	Peak output power (dBm)	LIMIT (dBm)	LIMIT (W)
CH02	2422	25.58	30	1
CH06	2437	25.84	30	1
CH09	2452	25.96	30	1

## 7. ANTENNA CONDUCTED SPURIOUS EMISSION

### 7.1 APPLIED PROCEDURES / LIMIT

20dBc in any 100 kHz bandwidth outside the operating frequency band. In case the emission fall within the restricted band specified on 15.205(a), then the 15.209(a) limit in the table below has to be followed.

Frequencies (MHz)	Field Strength (micorvolts/meter)	Measurement Distance (meters)
0.009~0.490	2400/F(KHz)	300
0.490~1.705	24000/F(KHz)	30
1.705~30.0	30	30
30~88	100	3
88~216	150	3
216~960	200	3
Above 960	500	3

The following table is the setting of the spectrum analyzer.

Spectrum Parameter	Setting
Attenuation	Auto
Span Frequency	100 MHz
RB / VB (emission in restricted band)	1MHz / 1MHz for Peak, 1 MHz / 10Hz for Average
RB / VB (other emission)	100 KHz /100 KHz for Peak

#### 7.1.1 TEST PROCEDURE

- a. The EUT was directly connected to the spectrum analyzer and antenna output port as show in the block diagram below,
- b. Spectrum Setting : RBW= 100KHz, VBW=100KHz, Sweep time = Auto.

#### 7.1.2 DEVIATION FROM STANDARD

No deviation.

### 7.1.3 TEST SETUP



### 7.1.4 EUT OPERATION CONDITIONS

The EUT tested system was configured as the statements of 4.1.6 Unless otherwise a special operating condition is specified in the follows during the testing.

7.1.5 TEST RESULTS

EUT :	IEEE 802.11b/g/n Long-Range USB Adapter	Model Name :	AWUS036NHR
Temperature :	25 °C	Relative Humidity :	60%
Pressure :	1012 hPa	Test Voltage :	DC5v from PC
Test Mode :	TX B MODE /CH01, CH11		



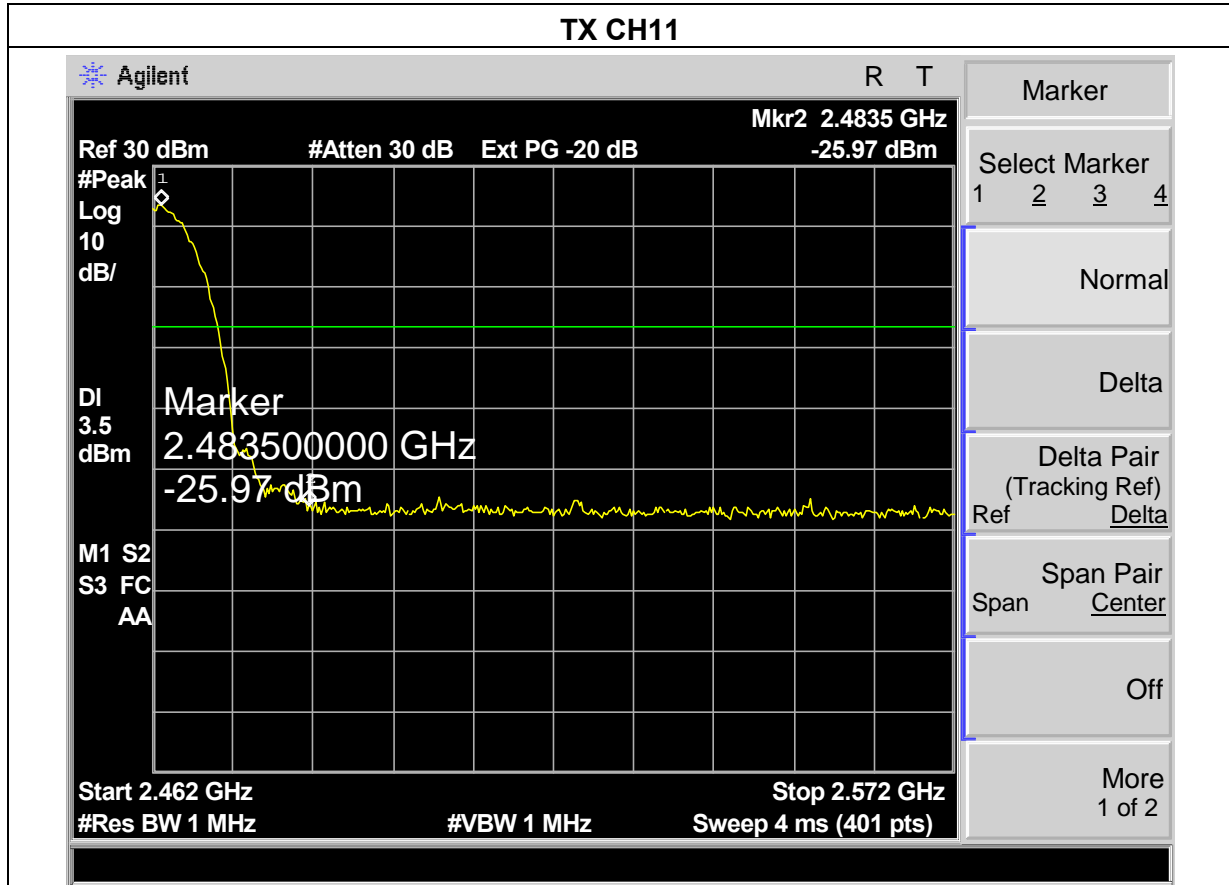

EUT :	IEEE 802.11b/g/n Long-Range USB Adapter	Model Name :	AWUS036NHR
Temperature :	25 °C	Relative Humidity :	60%
Pressure :	1012 hPa	Test Voltage :	DC 5V from PC
Test Mode :	TX G MODE /CH01, CH11		

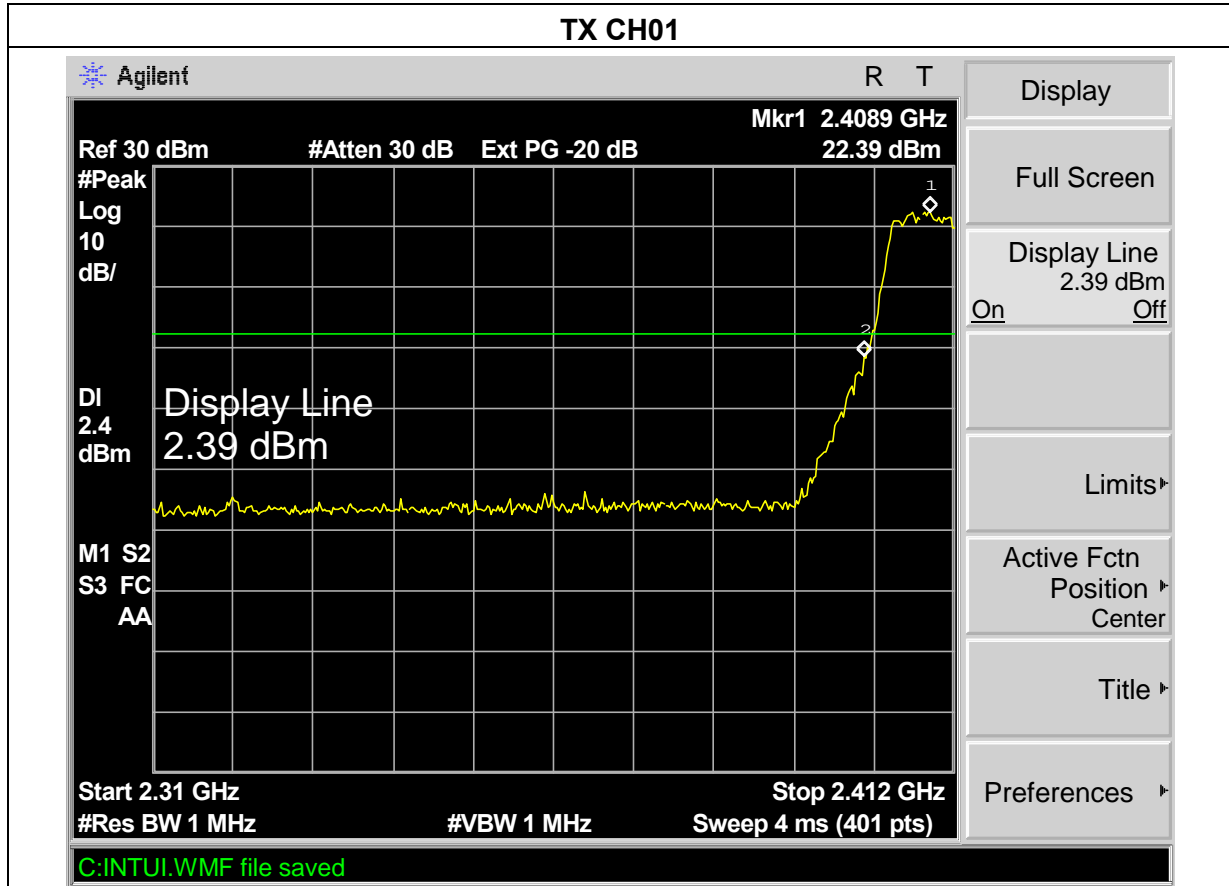



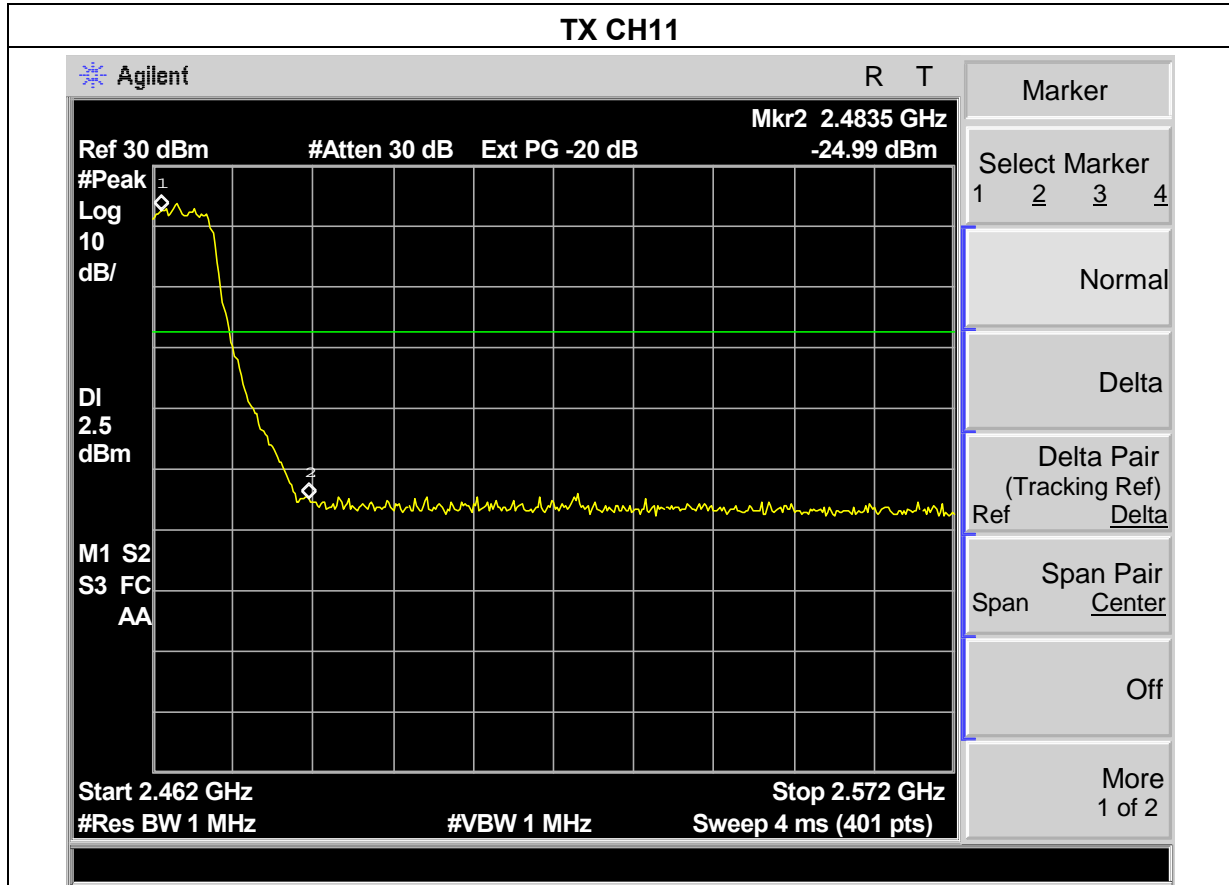

EUT :	IEEE 802.11b/g/n Long-Range USB Adapter	Model Name :	AWUS036NHR
Temperature :	25 °C	Relative Humidity :	60%
Pressure :	1012 hPa	Test Voltage :	DC 5V from PC
Test Mode :	TX N MODE /CH01, CH11(20MHz)		



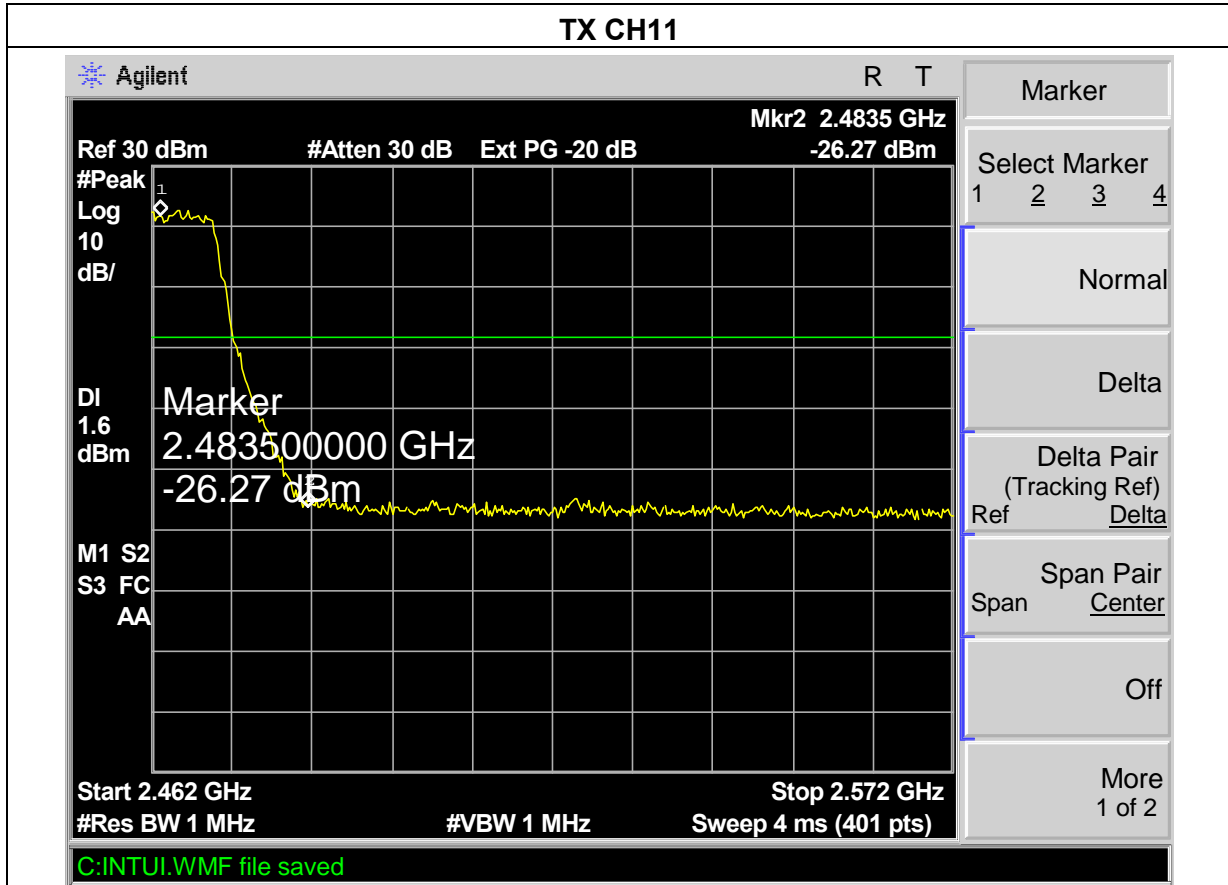

EUT :	IEEE 802.11b/g/n Long-Range USB Adapter	Model Name :	AWUS036NHR
Temperature :	25 °C	Relative Humidity :	60%
Pressure :	1012 hPa	Test Voltage :	DC5V from PC
Test Mode :	TX N MODE /CH03, CH09(40MHz)		



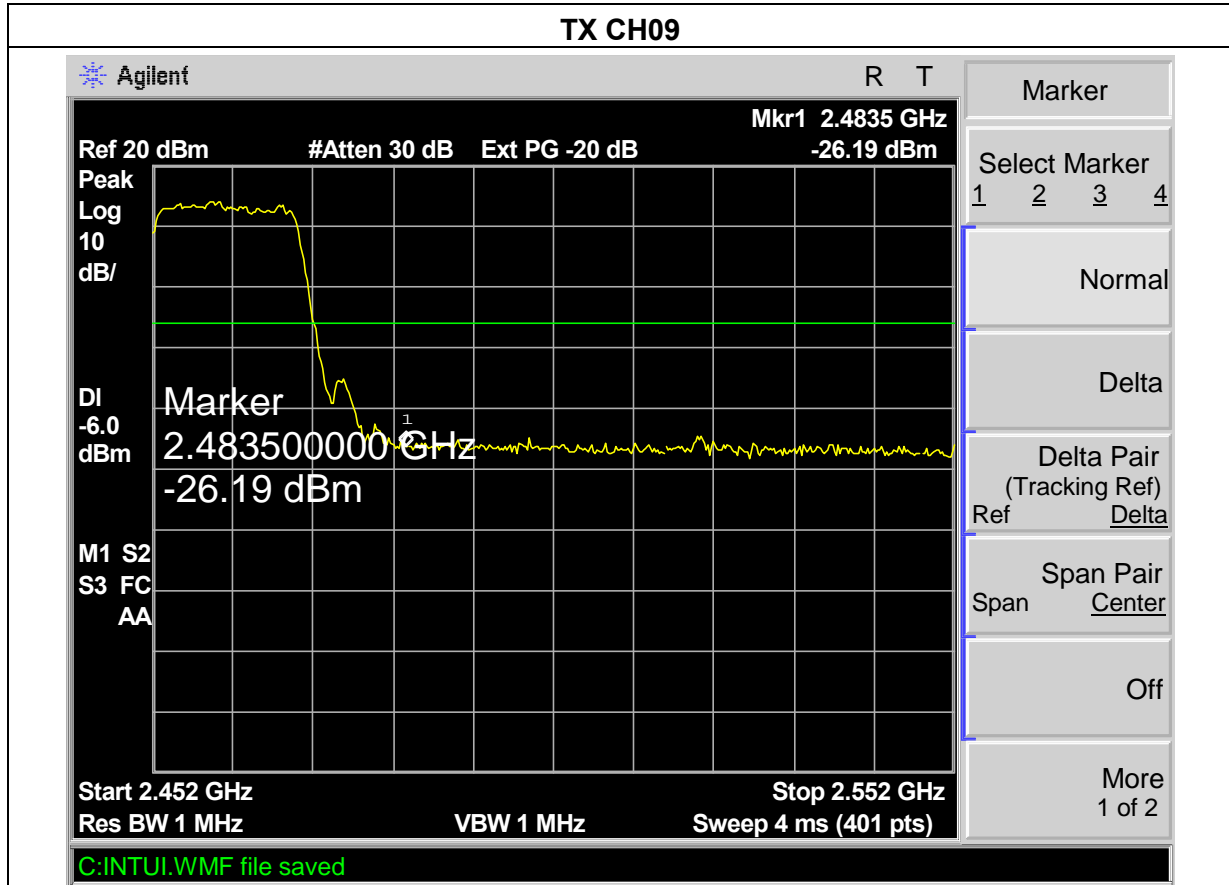

## 8. EUT TEST PHOTO

### Radiated Measurement Photos

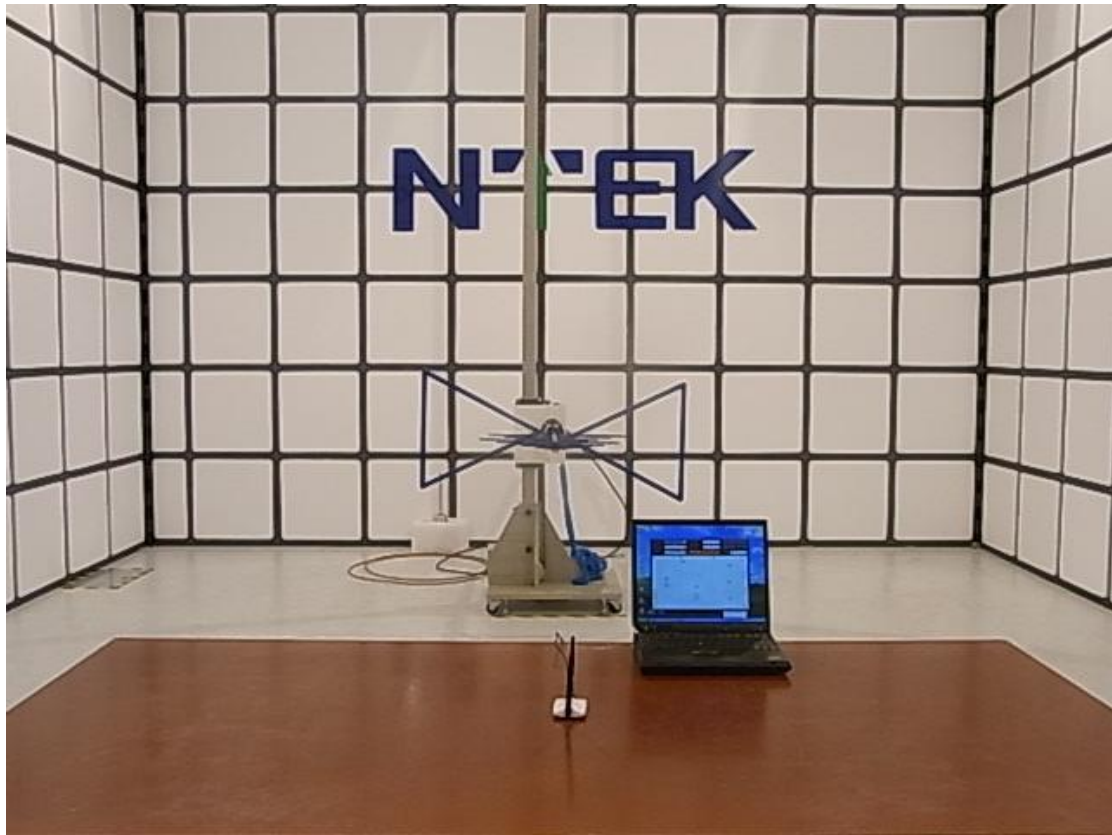

### Conducted Measurement Photos

