



CONFORMANCE TEST REPORT FOR HUMAN EXPOSURE TO ELECTROMAGNETIC FIELDS

Report No. : SRMC2009-H024-E0014

Product Name: GSM/GPRS/EDGE Tribands/WCDMA

Digital Mobile Phone

Product Model: H311A

Applicant: Inventec Appliances (Jiangning) Corporation

Manufacture: Inventec Appliances (Jiangning) Corporation

Specification: FCC OET Bulletin 65 (Edition 97-01)

Supplement C (Edition 01-01)

47CFR 2.1093

FCC ID: UPMW310001

The State Radio Monitoring Center

State Radio Spectrum Monitoring and Testing Center

No.80 Beilishi Road Xicheng District Beijing, China

Tel: 86-10-68009202 Fax: 86-10-68009205

Executive Summary

The H311A is a GSM/GPRS/EDGE Tribands/WCDMA Digital Mobile Phone. The phone can operate in the PCS1900MHz frequency range. The device has an internal integrated antenna. The system concepts used are the GSM1900 and GPRS1900 (Class 12) standards.

The objective of the measurements done by SRMC (The State radio monitoring center) was the dosimetric assessment of one device in the GSM1900 standards. The examinations have been carried out with the dosimetric assessment system, "DASY4".

The measurements were made according to FCC OET Bulletin 65 (Edition 97-01) Supplement C (Edition 01-01) and 47CFR 2.1093 Evaluating Compliance with FCC Guidelines for Human Exposure to Radiofrequency Electromagnetic Fields. All measurements have been performed in accordance to the recommendations given by SPEAG.

The maximum SAR of the H311A mobile phone is

Mode	CH/f(MHz)	Power	Position	Limit (mW/g)/1g	Measured (mW/g)	Result
GPRS1900	810/1909.8	29.9dBm	Towards ground	1.6	0.940	PASS

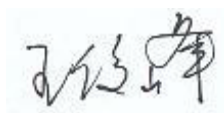
Checked By: 

Tested By: 

This Test Report Is Issued By: 

Issued date: **2009.10.21**

Tables of Contents

1. General information	3
1.1 Notes of the test report	3
1.2 Information about the testing laboratory	3
1.3 Applicant's details	3
1.4 Manufacturer's details	3
1.5 Application details	4
1.6 Information of Test Sample	4
1.7 Auxiliary Equipment (AE)	4
1.8 Reference	5
2. Subject of Investigation	6
2.1 The Standard IEC 62209-1-2005	6
2.2 Distinction Between Exposed Population, Duration of Exposure and Frequencies	6
2.3 Distinction between Maximum Permissible Exposure and SAR Limits	7
3 The IEC 62209-1-2005 Measurement Requirements	8
3.1 General Requirements	8
3.2 Phantom specifications (shell and liquid)	8
3.3 Specifications of the SAR measurement equipment	9
3.4 Scanning system specifications	9
3.5 Mobile phone holder specifications	9
4. Measurement preparation	9
4.1 General preparation	9
4.2 Simplified performance checking	10
4.3 Preparation of the mobile phone under test	10
4.4 Position of the mobile phone in relation to the phantom	10
4.5 Tests to be performed	11
5. The Measurement system	12
5.1 DAS4 Information	12
5.2 Test Equipments:	14
5.3 Uncertainty Assessment	15
6. Test Results	16
6.1 Test Environment:	16
6.2 Test Method and Procedure	16
6.3 Test Configuration	17
6.4 Test Results	17
7. Appendix	20
7.1 Administrative Data	20
7.2 Device under Test and Test Conditions	20
7.3 Tissue Recipes	22
7.4 Material Parameters	22
7.5 Simplified Performance Checking	24
7.6 Setup for System Performance Check	25

7.7 Test Results	27
7.8 Pictures of the device under test.....	38
7.9 Test Positions for the Device under test.....	38
7.10 Picture to demonstrate the required liquid depth	40
7.11 Certificate of conformity.....	40

1. General information

1.1 Notes of the test report

The test report may only be reproduced or published in full. Reproduction or publication of extracts from the report requires the prior written permission of The State Radio Monitoring Center.

The test results relate only to individual items of the samples which have been tested.

1.2 Information about the testing laboratory

Company: The State Radio Monitoring Center
State Radio Spectrum Monitoring and Testing Center
Address: No.80 Beilishi Road, Xicheng District, Beijing China
City: Beijing
Country or Region: China
Contacted person: Wang Junfeng
Tel: +86 10 68009181 +86 10 68009202
Fax: +86 10 68009195 +86 10 68009205
Email: Wangjf@srrc.org.cn

1.3 Applicant's details

Company: Inventec Appliances (Jiangning) Corporation
Address: 133, Jiangjun Road, Jiangning Economic and Technological
Development Zone
City: Nanjing, Jiangsu
Country or Region: P.R. China
Contacted person: William Zhang
Tel: +86 25 52262313
Fax: +86 25 52218366
Email: zhang.william@inventec-inc.com

1.4 Manufacturer's details

Company: Inventec Appliances (Jiangning) Corporation
Address: 133, Jiangjun Road, Jiangning Economic and Technological
Development Zone
City: Nanjing, Jiangsu
Country or Region: P.R.China
Contacted person: William Zhang
Tel: +86 25 52262313
Fax: +86 25 52218366
Email: zhang.william@inventec-inc.com

1.5 Application details

Date of receipt of test samples: 2009.7.30

Date of test: 2009.10.15

1.6 Information of Test Sample

□Name EUT	GSM/GPRS/EDGE Digital Mobile Phone with Bluetooth
□type	H311A
□Frequency range	PCS1900: Tx:1850~1910MHz Rx:1930~1990MHz Bluetooth: 2402-2480MHz
□Power Level	PCS1900:0 (30dBm) GPRS1900: 0(30dBm) EDGE 1900:2(26 dBm)
□Channel spacing	GSM/GPRS/EDGE: 200kHz Bluetooth: 1MHz
□Duty Cycle	GSM: 1:8 GPRS/EDGE: 1:4
□Modulation	GSM/GPRS/EDGE: GMSK/8PSK Bluetooth: GFSK
□Power supply	3.7V
□Test condition of declaration	Normal
Product Stage	production unit
□IMEI Number	355753030000001

1.7 Auxiliary Equipment (AE)

AE No.	Name	Model	Manufacturer	Serial Number
AE 1	Adapter	APW305UB-03-06	SHENZHEN ANTHIN POWER SUPPLY CO., LTD.	----
AE 2	Battery	PBH31IAZ10	Leung's communication & electric products(guangzhou) ltd.	----

1.8 Reference

IEC 62209-1-2005: Human exposure to radio frequency fields from hand-held and body-mounted wireless communication devices – Human models, instrumentation, and procedures –Part 1:Procedure to determine the specific absorption rate (SAR) for hand-held devices used in close proximity to the ear (frequency range of 300 MHz to 3 GHz)

ANSI C95.1–1999: IEEE Standard for Safety Levels with Respect to Human Exposure to Radio Frequency Electromagnetic Fields, 3 kHz to 300 GHz

OET Bulletin 65 (Edition 97-01) and Supplement C(Edition 01-01): Additional Information for Evaluating Compliance of Mobile and Portable Devices with FCC Limits.

47CFR 2.1093

IEEE 1528–2003: Recommended Practice for Determining the Peak Spatial-Average Specific Absorption Rate (SAR) in the Human Body Due to Wireless Communications Devices: Experimental Techniques.

“SAR Evaluation Considerations for Handsets with Multiple Transmitters and Antennas--Sept 2008”- 648474 D01 SAR Handsets Multi Xmitter and Ant, v01r05

[DAY4]

Schmid & partner Engineering AG: DAY4 Manual. Nov.2003

2. Subject of Investigation

The H311A is a GSM/GPRS/EDGE Tribands/WCDMA Digital Mobile Phone. The phone can operate in the PCS1900MHz frequency range. The device has a internal integrated antenna. The system concepts used are the GSM1900 and GPRS1900 (Class 12) standards.



Fig 1: picture of the device under test

The objective of the measurements done by SRMC was the domestic assessment of one device in the GSM 1900 standard. The examinations have been carried out with the domestic assessment system “DASY4” described below.

2.1 The Standard IEC 62209-1-2005

IEC 62209-1-2005 is Basic standard for Human exposure to radio frequency fields from hand-held and body-mounted wireless communication devices – Human models, instrumentation, and procedures –Part 1:Procedure to determine the specific absorption rate (SAR) for hand-held devices used in close proximity to the ear (frequency range of 300 MHz to 3 GHz)

2.2 Distinction Between Exposed Population, Duration of Exposure and Frequencies

The European Standard [CENELEC2001] distinguishes between controlled and uncontrolled environment. Controlled environments are locations where there is exposure that may be incurred by persons who are aware of the potential for exposure as a concomitant of employment or by other cognizant

persons-Uncontrolled environments are locations where there is the exposure of individuals who have no knowledge or control of their exposure. The exposures may occur in living quarters or workplaces. For exposure in controlled environments higher field strengths are admissible. In addition the duration of exposure is considered.

Due to the influence of frequency on important parameters, as the penetration depth of the electromagnetic fields into the human body and the absorption capability of different tissues, the limits in general vary with frequency.

ANSI C95.1–1999: IEEE Standard for Safety Levels with Respect to Human Exposure to Radio Frequency Electromagnetic Fields, 3 kHz to 300 GHz. It specifies the maximum exposure limit of 1.6 W/kg as averaged over any 1 gram of tissue for portable devices being used within 20 mm of the user in the uncontrolled environment.

2.3 Distinction between Maximum Permissible Exposure and SAR Limits

The biological relevant parameter describing the effects of electromagnetic fields in the frequency range of interest is the specific absorption rate SAR (dimension: power/mass). It is a measure of the power absorbed per unit mass. The SAR may be spatially averaged over the total mass of an exposed body or its parts. The SAR is calculated from the r.m.s. electric field strength E inside the human body, the conductivity σ and the mass density ρ of the biological tissue:

$$SAR = \frac{\sigma E_i^2}{\rho}$$
$$SAR = c_i \left. \frac{dT}{dt} \right|_t = 0$$

The specific absorption rate describes the initial rate of temperature rise dT/dt as a function of the specific heat capacity c of the tissue. A limitation of the specific absorption rate prevents an excessive heating of the human body by electromagnetic energy.

As it is sometimes difficult to determine the SAR directly by measurement (e.g. whole body averaged SAR), the standard specifies more readily measurable maximum permissible exposures in terms of external electric E and magnetic field strength H and power density S , derived from the SAR limits. The limits for E , H and S have been fixed so that even under worst case conditions, the limits for the specific absorption rate SAR are not exceeded.

For the relevant frequency range the maximum permissible exposure may be exceeded if the exposure can be shown by appropriate techniques to produce SAR values below the corresponding limits.

3 The IEC 62209-1-2005 Measurement Requirements

This basic standard applies to any electromagnetic field (EM) transmitting devices intended to be used with the radiating part of the equipment in close proximity to the human ear including mobile phones, cordless phones, etc. The frequency range is 300 MHz to 3 GHz.

The objective of the standard is to specify the method for demonstration of compliance with the Specific absorption rate (SAR) limits for such equipment. The measurement system is composed of the phantom, the SAR measurement equipment, the scanning system and the mobile phone holder.

3.1 General Requirements

The test shall be performed using a miniature probe that is automatically positioned to measure the internal E-field distribution in a phantom model representing the human head exposed to the EM fields produced by mobile phones. From the measured E-field values, the SAR distribution and the maximum mass averaged SAR value shall be calculated.

The test shall be performed in a laboratory conforming to the following environmental conditions:

- the ambient temperature shall be in the range of 15 °C to 30°C and the variation shall not exceed 2 °C during the test;
- the mobile phone shall not interact with the local mobile networks;
- care shall be taken to avoid significant influence on SAR measurements by ambient EM sources;
- care shall be taken to avoid significant influence on SAR measurements by any reflection from the environment (such as floor, positioner, etc.).
- Validation of the system shall be done at least once a year according to the protocol defined in annex D of IEC 62209-1-2005 Standard.

3.2 Phantom specifications (shell and liquid)

Phantom requirements

The physical characteristics of the phantom model (size and shape) shall resemble the head and neck of a user since the shape is a dominant parameter for exposure. The phantom shall be made from material with dielectric properties similar to those of head tissues. To enable field scanning within it, the material shall be liquid contained in a head and neck shaped shell model. The shell model acts as a shaped container and shall be as unobtrusive as possible. The hand shall not be modeled.

The shell of the phantom shall be made of low loss and low permittivity material: $\tan(\delta) \leq 0,05$ and $\epsilon \leq 5$. The thickness of the phantom is defined in the CAD files and the tolerance shall be $\pm 0,2$ mm in the area defined in the CAD files (where the phone touches the head).

Reference points on the phantom:

The probe positioning shall be defined in relation to three well defined points on the phantom. These points R1, R2 and R3 shall be used to calibrate the positioning system. Three other points, M for mouth, LE for left ear and/or RE for right ear (maximum acoustic coupling), shall be defined on the phantom(s) (see Figure 2). These points shall be used to allow reproducible positioning of the mobile phone in relation to the phantom.

3.3 Specifications of the SAR measurement equipment

The measurement equipment shall be calibrated as a complete system. The probe shall be calibrated together with the amplifier, measurement device and data acquisition system.

The measurement equipment shall be calibrated in each tissue equivalent liquid at the appropriate operating frequency and temperature according to the methodology defined in IEC 62209-1-2005 .The minimum detection limit shall be lower than 0,02 W/kg and the maximum detection limit shall be higher than 100 W/kg. The linearity shall be within 0,5 dB over the SAR range from 0,02 to 100 W/kg. The isotropy shall be within 1 dB. Sensitivity, linearity and isotropy shall be determined in the tissue equivalent liquid. The response time shall be specified. .

3.4 Scanning system specifications

The scanning system holding the probe shall be able to scan the whole exposed volume of the phantom in order to evaluate the three-dimensional SAR distribution. The mechanical structure of the scanning system shall not interfere with the SAR measurements.

The accuracy of the probe tip positioning over the measurement area shall be less than 0,2 mm. The sampling resolution shall be 1 mm or less.

3.5 Mobile phone holder specifications

The mobile phone holder shall permit the phone to be positioned according to a tolerance of 1° in the tilt angle. It shall be made of low loss and low permittivity material(s): $\tan(\delta) \leq 0,05$ and $\epsilon \leq 5$.

4. Measurement preparation

4.1 General preparation

The dielectric properties of the tissue equivalent materials shall be measured prior to the SAR measurements and at the same temperature with a tolerance of 2° C. The measured values shall comply with the values defined at the specific frequencies in IEC 62209-1-2005 6.1.1. with a tolerance of 5 % for

relative permittivity and conductivity.

The phantom shell shall be filled with the tissue equivalent liquid. The depth of the tissue equivalent liquid inside the phantom and at the vertical position of the ear canal shall be at least 15 cm. The liquid shall be carefully stirred before the measurement and it shall be free of air bubbles. The coordinate system of the scanning system shall be aligned to the coordinate system of the phantom with a tolerance of 0,2 mm.

4.2 Simplified performance checking

The purpose of the simplified performance check is to verify that the system operates within its specifications, check is a simple test of repeatability to make sure that the system works correctly during the compliance test. The check shall be performed in order to detect possible drift over short time periods and other errors in the system,

The simplified performance check shall be carried out according to annex D of IEC 62209-1-2005. The simplified performance check shall be performed prior to compliance tests and the result shall be within $\pm 10\%$ of the target value. After the system validation check. The simplified performance check shall be performed at a central frequency of each transmitting band of the mobile phone.

4.3 Preparation of the mobile phone under test

The tested mobile phone shall use its internal transmitter. The battery shall be fully charged before each measurement. The output power and frequency (channel) shall be controlled by 8960(base station simulator). H311A transmit its highest output peak power level allowed by the system. , The BTS antenna shall be placed at least 50 cm from the phone. The signal emitted by the emulator at antenna feed point shall be lower than the output level of the phone by at least 30 dB.

4.4 Position of the mobile phone in relation to the phantom

The mobile phone shall be tested in the cheek and tilted positions on left and right sides of the phantom.

Definition of the cheek position:

- a) Position the device with the vertical centre line of the body of the device and the horizontal line crossing the centre of the ear piece in a plane parallel to the sagittal plane of the phantom. While maintaining the device in this plane, align the vertical centre line with the reference plane containing the three ear and mouth reference points (M, RE and LE) and align the centre of the ear piece with the line RE-LE;
- b) Translate the mobile phone box towards the phantom with the ear piece aligned with the line LE-RE until the phone touches the ear. While maintaining the device in the reference plane and maintaining the phone contact with the

ear, move the bottom of the box until any point on the front side is in contact with the cheek of the phantom or until contact with the ear is lost.

Definition of the tilted position:

- a) Position the device in the Tilt position described above;
- b) While maintaining the device in the reference plane described above and pivoting against the ear, move it outward away from the mouth by an angle of 15 degrees or until contact with the ear is lost. (see Figure 2)

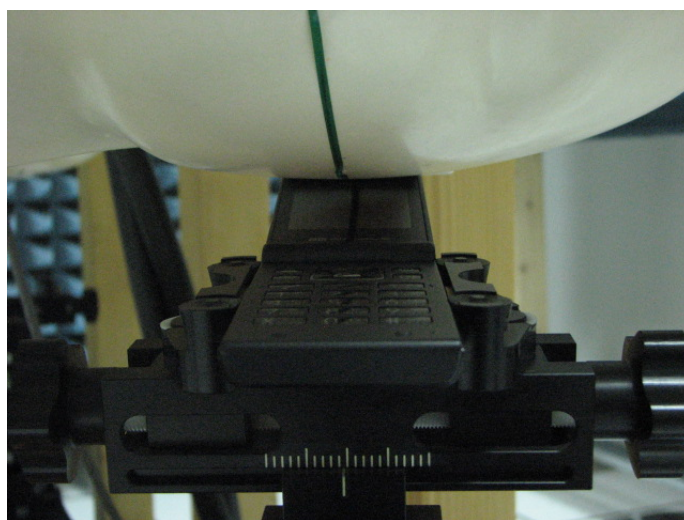

Fig 2 - Definition of the reference lines and points, on the phone and on the phantom and initial position

4.5 Tests to be performed

Tests shall be performed with both phone positions described in 4.4, on the left and right sides of the head and using the centre frequency of each operating band. The configuration giving rise to the maximum mass-averaged SAR shall be used to test the low-end and the high-end frequencies of the transmitting band. If the mobile phone has a retractable antenna, all of the tests described above shall be performed both with .The antenna extended and with it retracted. When considering multi- mode and multi-band mobile phones, all of the above tests shall be performed in each transmitting mode/band with the corresponding maximum peak power level.

5. The Measurement system

5.1 DASY4 Information

DASY4 is an abbreviation of "Dosimetric Assessment System" and describes a system that is able to determine the SAR distribution inside a phantom of a human being according to different standards. The DASY4 system consists of the following items as shown in Fig3. Fig4 shows the installation in the SRMC laboratory [DASY2004].

- High precision robot with controller
- Measurement server(for surveillance of the robot operation and signal filtering)
- Data acquisition electronics DAE (for signal amplification and altering)
- Field probes calibrated for use in liquids
- Electro-optical converter EOC (conversion from the optical into a digital signal)
- Light beam (improving of the absolute probe positioning accuracy)
- Two SAM phantoms filled with tissue simulating liquid
- DASY4 software
- SEMCAD

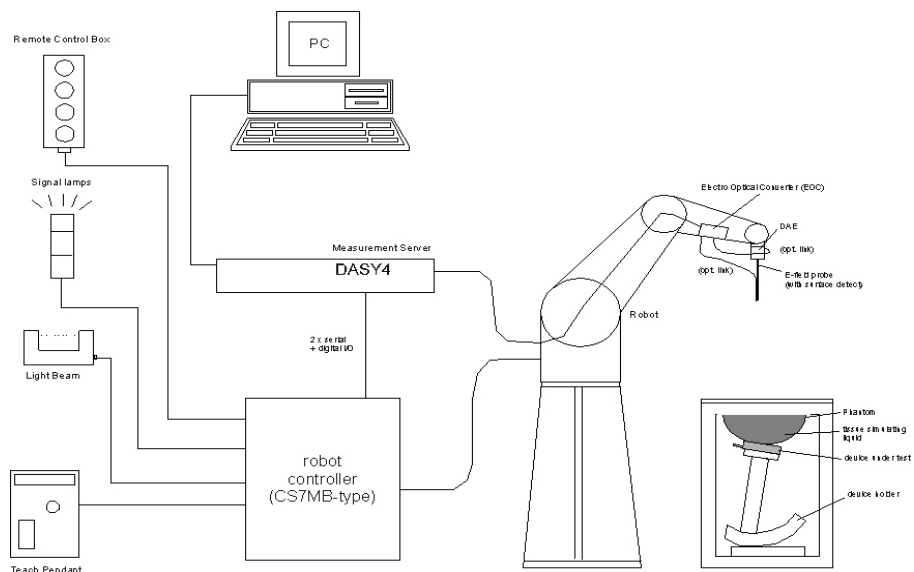

Fig3. The DASY4 measurement system

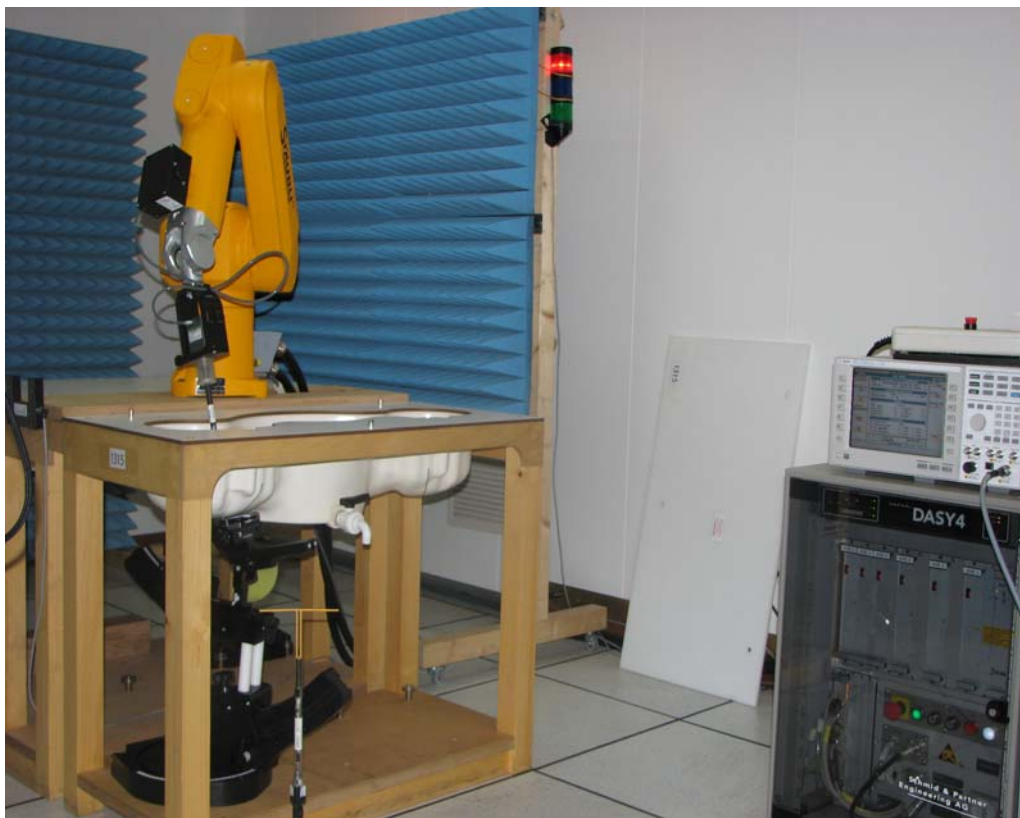

Fig 4. The measurement set-up with two SAM phantoms containing tissue simulating liquid

5.2 Test Equipments:

Name		Serial Number	Last Cal. Data
DASY4 SYSTEM			
Software Version	V4.7	N/A	N/A
Dosimetric E-Field probe	ES3DV3	3128	2009.06
Data Acquisition Electronics	DAE4	725	2009.06
Phantom	SAM	1267	N/A
Phantom	SAM	1315	N/A
Performance checking			
System Validation Dipole	D835V2	473	2008.06
System Validation Dipole	D1900V2	5d024	2008.06
RF source	E4428C	MY45280865	2008.8
RF Amplifier	5S1G4	0323472	N/A
Power Meter	E4417A	MY45101182	2008.8
Power Meter probe	E4412A	MY41502214	2008.8
Power Meter probe	E4412A	MY41502130	2008.8
Attenuator	2	BM0059	2008.8
Attenuator	2	BM6452	2008.8
Attenuator	2	BM8993	2008.8
Directional Coupler	778D-012	13733	2008.8
Material Measurement			
Network Analyzer	8714ET	US40372083	2008.8
Dielectric Probe Kit	85070D	US33030365	N/A
General			
Radio Tester	8960	GB43194054	2008.8

Note: the Dipole Calibration interval is 24 months

Table 1. Test Equipments lists

5.3 Uncertainty Assessment

DASY4 Uncertainty Budget According to IEC 62209-1 [3]								
Error description	Uncertainty value	Prob. Dist.	Div.	(c_i) 1g	(c_i) 10g	Std.Unc (1g).	Std.Unc. (10g)	(v_i) V_{eff}
Measurement system								
Probe calibration	±5.9%	N	1	1	1	±5.9%	±5.9%	∞
Axial isotropy	±4.7%	R	$\sqrt{3}$	0.7	0.7	±1.9%	±1.9%	∞
Hemispherical isotropy	±9.6%	R	$\sqrt{3}$	0.7	0.7	±3.9%	±3.9%	∞
Boundary effects	±1.0%	R	$\sqrt{3}$	1	1	±0.6%	±0.6%	∞
Linearity	±4.7%	R	$\sqrt{3}$	1	1	±2.7%	±2.7%	∞
System detection limits	±1.0%	R	$\sqrt{3}$	1	1	±0.6%	±0.6%	∞
Readout electronics	±0.3%	N	1	1	1	±0.3%	±0.3%	∞
Response time	±0.8%	R	$\sqrt{3}$	1	1	±0.5%	±0.5%	∞
Integration time	±2.6%	R	$\sqrt{3}$	1	1	±1.5%	±1.5%	∞
RF ambient noise	±3.0%	R	$\sqrt{3}$	1	1	±1.7%	±1.7%	∞
RF ambient reflections	±3.0%	R	$\sqrt{3}$	1	1	±1.7%	±1.7%	∞
Probe positioner	±0.4%	R	$\sqrt{3}$	1	1	±0.2%	±0.2%	∞
Probe positioning	±2.9%	R	$\sqrt{3}$	1	1	±1.7%	±1.7%	∞
Max.SAR Eval.	±1.0%	R	$\sqrt{3}$	1	1	±0.6%	±0.6%	∞
Test Sample Related								
Device Positioning	±2.9%	N	1	1	1	±2.9%	±2.9%	145
Device holder	±3.6%	N	1	1	1	±3.6%	±3.6%	5
Power drift	±5.0%	R	$\sqrt{3}$	1	1	±2.9%	±2.9%	∞
Phantom and Setup								
Phantom uncertainty	±4.0%	R	$\sqrt{3}$	1	1	±2.3%	±2.3%	∞
Liquid conductivity(target)	±5.0%	R	$\sqrt{3}$	0.64	0.43	±1.8%	±1.2%	∞
Liquid conductivity(meas.)	±2.5%	N	1	0.64	0.43	±1.6%	±1.1%	∞
Liquid conductivity(target)	±5.0%	R	$\sqrt{3}$	0.6	0.49	±1.7%	±1.4%	∞
Liquid onductivity(means.)	±2.5%	N	1	0.6	0.49	±1.5%	±1.2%	∞
Combined std. Uncertainty						±10.9%	±10.7%	387
Expanded STD Uncertainty						±21.9%	±21.4%	

Table 2. Uncertainty assessment

6. Test Results

6.1 Test Environment:

Ambient Temperature: 24.0°C Relative Humidity: 35.5% Atmosphere:
101.0kPa

6.2 Test Method and Procedure

a) Measure the local SAR at a test point within 10 mm of the inner surface of the phantom. The test point shall also be close to the ear;

b) verify that the measured SAR at the point used in item 1 is stable after 3 minutes within $\pm 5\%$ in order to ensure that there is no drift due to the mobile phone electronics;

c) Measure the SAR distribution within the phantom. The spatial grid step shall be less than 20 mm. If surface scanning is used, then the distance between the geometrical centre of the probe detectors and the inner surface of the phantom shall be constant within $\pm 0,5$ mm and less than 8 mm. If volume scanning is performed, then the scanning volume shall be as close as possible to the inner surface of the phantom (less than 8 mm), the grid step shall be 5 mm or less, the grid shall extend to a depth of 25 mm and then go directly to item 6;

d) From the scanned SAR distribution, identify the position of the maximum SAR value, as well as the positions of any local maxima with SAR values of more than 50 % of the maximum value;

e) Measure SAR with a grid step less than 5 mm in a volume with a minimum size of 30 mm by 30 mm and 25 mm in depth. Separate grids shall be centred on each of the local SAR maxima;

f) Use interpolation and extrapolation procedures defined in annex C of IEC 62209-1-2005 to determine the local SAR values at the spatial resolution needed for mass averaging;

g) Repeat the SAR measurement at the initial test point used in item 1. If the two results differ by more than $\pm 5\%$ from the final value obtained in item 2, the measurements shall be repeated with a fully charged battery or the actual drift shall be included in the uncertainty evaluation.

Tests shall be performed with both phone positions of cheek and tilted, on the left and right sides of the head and using the centre frequency of each operating band. Then the configuration giving rise to the maximum mass-averaged SAR shall be used to test the low-end and the high-end frequencies of the transmitting band. If the mobile phone has a retractable antenna, all of the tests described above shall be performed both with the antenna extended and with it retracted. When considering multi- mode and

multi-band mobile phones, all of the above tests shall be performed in each transmitting mode/band with the corresponding maximum peak power level.

6.3 Test Configuration

The test shall be performed in the shield room.

Please refer to chapter 7.8; 7.9 of this test report for photo of this test setup.

6.4 Test Results

During the process of testing, the EUT was controlled via Rhode & Schwarz Digital Radio Communication tester (CMU-200) to ensure the maximum power transmission and proper modulation. This result contains conducted output power and ERP for the EUT. In all cases, the measured peak output power should be greater and within 5% than EMI measurement.

Refer to “SAR Evaluation Considerations for Handsets with Multiple Transmitters and Antennas--Sept 2008 ” When stand-alone SAR evaluation is not required and the antenna is ≥ 5 cm from other antennas, simultaneous transmission SAR evaluation is also not required for that antenna. Therefore, it does not need to be included in the simultaneous transmission evaluation of other antennas that require it. so Bluetooth would not be included in the SAR report.

Mode: GSM1900

f_L (MHz)=1850.2MHz f_M (MHz)=1880.0MHz f_H (MHz)=1909.8MHz

SAR Values (Head, 1900MHz Band)

Limit of SAR (W/kg)	1 g Average
	1.6
Test Case	Measurement Result (mW/g)
	1 g Average
Left hand, Touch cheek , f_H	---
Left hand, Touch cheek, f_M	0.129
Left hand, Touch cheek , f_L	---
Left hand, Tilt 15 Degree, f_M	0.052
Right hand, Touch cheek , f_H	---
Right hand, Touch cheek, f_M	0.116
Right hand, Touch cheek f_L	---
Right hand, Tilt 15 Degree, f_M	0.041

So, the maximum SAR is

		SAR(mW/g)
--	--	------------------

Configuration	Position	f _L (MHz)	f _M (MHz)	f _H (MHz)
Left Side	cheek	---	0.129	---

Note1: Please refer to 7.7 of this test report for graphical results.

Table 3. SAR Results

Mode: GSM1900

f_L(MHz)=1850.2MHz f_M(MHz)=1880.0MHz f_H(MHz)=1909.8MHz

SAR Values (Body, 1900MHz Band) with the headset

Limit of SAR (W/kg)	1g Average	
	1.6	
Test Case	Measurement Result (mW/g)	
	1g Average	
Towards ground f _H	---	
Towards ground f _M	0.156	
Towards ground f _L	---	
Back ground f _H	---	
Back ground f _M	0.138	
Back ground f _L	---	

So, the maximum SAR is

Phantom Configuration	SAR(mW/g)		
	f _L (MHz)	f _M (MHz)	f _H (MHz)
Towards ground	---	0.156	---

Table 4. SAR Results

Mode: GPRS 1900/EDGE 1900

f_L (MHz)=1850.2MHz f_M (MHz)=1880.0MHz f_H (MHz)=1909.8MHz

SAR Values (Body, 1900MHz Band with Bluetooth)

Limit of SAR (W/kg)		1g Average
		1.6
Test Case		Measurement Result (mW/g)
		1g Average
Towards ground	f_H GPRS	0.940
Towards ground	f_M GPRS	0.660
Towards ground	f_L GPRS	0.828
Towards ground	f_H EDGE	---
Towards ground	f_M EDGE	0.514
Towards ground	f_L EDGE	---

So, the maximum SAR is

Phantom Configuration	SAR(mW/g)		
	f_L (MHz)	f_M (MHz)	f_H (MHz)
Towards ground	---	0.940	---

Table 5. SAR Results

7. Appendix

7.1 Administrative Data

Date of validation: 2009.7.30
 Date of measurement: 2009.7.30
 Data stored: SRMC2009-H024-E0014

7.2 Device under Test and Test Conditions

TYPE: H311A

Date of receipt: 2009.7.30

IMEI: 355753030000001

Equipment class: Portable device

Power Class: GSM1900 tested with power level 0 (30dBm)
 GPRS1900 tested with power level 0 (30dBm)
 EDGE 1900 tested with power level 2(26 dBm)

RF exposure environment: General Population

Power supply: Internal Battery (Other batteries not available)

Measurement Standards: GSM1900

Method to establish a call: GSM1900: Base station simulator, using the air interface

Modulation: GMSK / 8PSK

TX range: GSM1900:1850~1910MHz

RX range: GSM1900:1930~1990MHz

Used TX Channels: L: ch512; M: ch661; H: ch810 (refer to the table 5)

Mode	GSM850(Head/Body)			GSM1900(Head/Body)		
	Duty cycle: 1:8(12.5%)			Duty cycle: 1:8(12.5%)		
Channel	---	---	---	512	661	810
Frequency(MHz)	---	---	---	1850.2	1880.0	1909.8
Measured Power(dBm)	---	---	---	29.7	29.7	29.7

Mode	GPRS850(Body) Duty cycle: 1:4(25%)			GPRS1900(Body) Duty cycle: 1:4(25%)		
	Channel	---	---	512	661	810
Frequency(MHz)	---	---	---	1850.2	1880.0	1909.8
Measured Power(dBm)	---	---	---	29.8	29.6	29.9

Mode	EDGE850 Duty cycle: 1:2(50%)			EDGE1900 Duty cycle: 1:2(50%)		
	Channel	---	---	512	661	810
Frequency(MHz)	---	---	---	1850.2	1880.0	1909.8
Measured Power(dBm)	---	---	---	24.2	24.1	24.0

Note: The GPRS Mode is tested with a duty cycle of 1:4 (25%) in the worst case configuration in each band, and the EDGE Mode is tested with a duty cycle of 1:2 (50%) in the worst case configuration in each band.

Table 6. Frequency and Measured power of EUT's Tx channels

Used Phantom: SAM Twin Phantom V4.0, as defined by IEC 62209-1-2005 and delivered by Schmid&Parb1er Engineering AG

7.3 Tissue Recipes

Head Tissue Simulant

The following recipes are provided in percentage by weight.

1900 MHz:

44,45 %	2-(2-butoxyethoxy) ethanol
55.24 %	de-ionised water
0.31 %	NaCl salt

Body Tissue Simulant

The following recipes are provided in percentage by weight.

1900MHz:

70.17%	de-ionised water
29.44%	DGBE
0.39 %	Salt

7.4 Material Parameters

For the measurement of the following parameters the HP 85070D dielectric probe kit is used, representing the open-ended coaxial probe measurement procedure. Liquid temperature during the test: 22.3°C, tested date 2009.7.30.

Head		ϵ_r	σ [S/m]	Temperature	
				Ambient [°C]	Liquid [°C]
1900MHz	Recommended Value	40±1.9	1.40±0.07	15-30	-
	Measured Value	39.0	1.44	24.0	22.3

Body		ϵ_r	σ [S/m]	Temperature	
				Ambient [°C]	Liquid [°C]
1900MHz	Recommended Value	53.3±2.7	1.52±0.08	15-30	-
	Measured Value	54.6	1.49	24.0	22.3

Table7: Parameters of the head tissue simulating liquids

7.5 Simplified Performance Checking

The manufacturer calibrates the probes annually. Dielectric parameters of the tissue simulants were measured every day using the dielectric probe kit and the network analyser. A system check measurement was made following the determination of the dielectric parameters of the simulant, using the dipole validation kit. A power level of 250 mW was supplied to the dipole antenna, which was placed under the flat section of the twin SAM phantom. The system checking results (dielectric parameters and SAR values) are given in the table below.

The target values were adopted from the manufactures calibration certificates which are attached in the appendix. Table 9 includes the uncertainty assessment for the system performance checking which was suggested by the IEC 62209-1-2005 and determined by Schmid & Partner Engineering AG. The expanded uncertainty is assessed to be $\pm 21.9\%$.
 Liquid temperature during the test: 22.3°C. System validation date: 2009.7.30

		SAR _{1g} [w/kg]	ϵ_r	σ [S/m]	Temperature	
					Ambient[°C]	Liquid[°C]
1900MHz	Target Value	39.7	40±1.9	1.40±0.07	15-30	-
	Measured Value	39.9	39.0	1.44	24.0	22.3

All SAR values are normalized to 1W forward power. Plot of the system checking scans are given in Appendix7.7

Table 8: Validation results, 1900 MHz

7.6 Setup for System Performance Check

(see also Chapter 16 System Performance Check of DAY 4 System handbook)

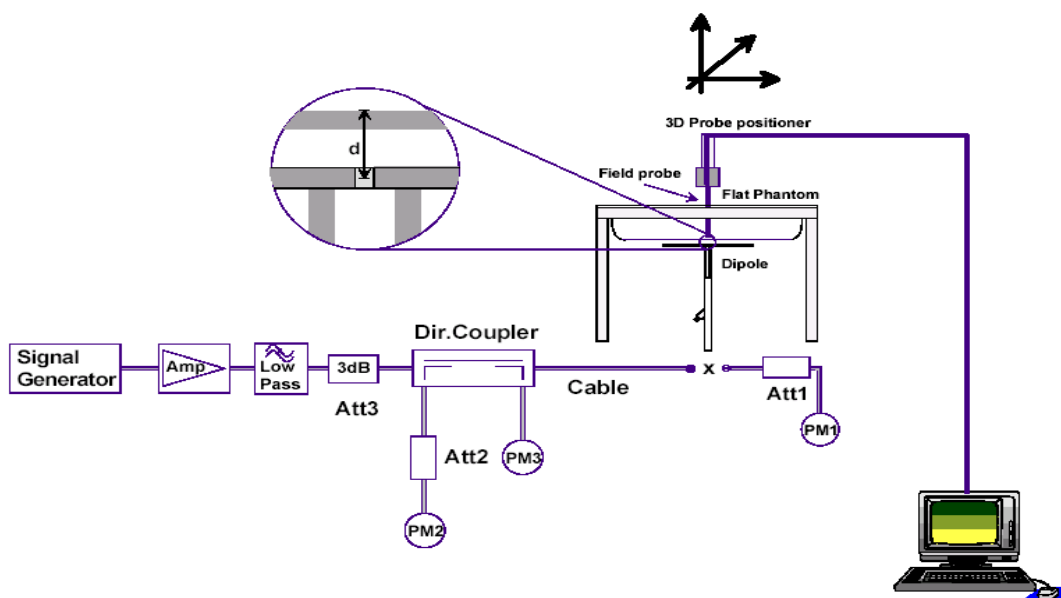

Fig5. Setup for system performance Check

First the power meter PM1 is connected to the cable and it measures the forward power at the location of the dipole connector (X). The signal generator is adjusted for the desired forward power at the dipole connector (taking into account the (Att1) value) and the power meter PM2 is read at that level. Then after connecting the cable to the dipole, the signal generator is readjusted for the same reading at the power meter PM2. If the signal generator does not allow a setting in 0,01 dB steps, the remaining difference at PM2 must be taken into consideration. PM3 records the reflected power from the dipole and ensures that the value is not changed from the previous value. The reflected power should be 20 dB below the forwarded power.

Error description	ToL.	Prob. Dist.	Div.	(c_i) 1g	(c_i) 10g	Std.Unc (1g).	Std.Unc (10g)	(v_i) V_{eff}
Measurement system								
Probe calibration	±5.9%	N	1	1	1	±5.9%	±5.9%	∞
Axial isotropy	±4.7%	R	$\sqrt{3}$	1	1	±2.7%	±2.7%	∞
Hemispherical isotropy	±9.6%	R	$\sqrt{3}$	0	0	0	0	∞
Boundary effects	±1.0%	R	$\sqrt{3}$	1	1	±0.6%	±0.6%	∞
Linearity	±4.7%	R	$\sqrt{3}$	1	1	±2.7%	±2.7%	∞
System detection limits	±1.0%	R	$\sqrt{3}$	1	1	±0.6%	±0.6%	∞
Readout electronics	±0.3%	N	1	1	1	±0.3%	±0.3%	∞
Response time	0	R	$\sqrt{3}$	1	1	0	0	∞
Integration time	0	R	$\sqrt{3}$	1	1	0	0	∞
RF ambient noise	±3.0%	R	$\sqrt{3}$	1	1	±1.7%	±1.7%	∞
RF ambient reflections	±3.0%	R	$\sqrt{3}$	1	1	±1.7%	±1.7%	∞
Probe positioner	±0.4%	R	$\sqrt{3}$	1	1	±0.2%	±0.2%	∞
Probe positioning	±2.9%	R	$\sqrt{3}$	1	1	±1.7%	±1.7%	∞
Algorithms for Max.SAR Eval.	±1.0%	R	$\sqrt{3}$	1	1	±0.6%	±0.6%	∞
Dipole								
Dipole Axis to Liquid Distance	±2.0%	R	$\sqrt{3}$	1	1	±1.2%	±1.2%	∞
Input power and SAR drift meas.	±4.7%	N	1	1	1	±2.7%	±2.7%	∞
Phantom and Tissue Param								
Phantom uncertainty	±4.0%	R	$\sqrt{3}$	1	1	±2.3%	±2.3%	∞
Liquid conductivity(target)	±5.0%	R	$\sqrt{3}$	0.64	0.43	±1.8%	±1.2%	∞
Liquid conductivity(meas.)	±2.5%	N	1	0.64	0.43	±1.6%	±1.1%	∞
Liquid conductivity(target)	±5.0%	R	$\sqrt{3}$	0.6	0.49	±1.7%	±1.4%	∞
Liquid conductivity (means.)	±2.5%	N	1	0.6	0.49	±1.5%	±1.2%	∞
Combined std. Uncertainty						±9.2%	±8.9%	∞
Coverage Factor for 95%		$k_p = 2$						
Expanded STD Uncertainty						±18.4%	±17.8%	

Table 9:Uncertainty Budget for the system performance check

7.7 Test Results

SYSTEM CHECKING SCANS

1900 MHz

DUT: Dipole 1900 MHz; Type: D1900V2; Serial: D1900V2 - SN:5d113

Medium parameters used (interpolated): $f = 1900$ MHz; $\sigma = 1.44$ mho/m; $\epsilon_r = 39$; $\rho = 1000$ kg/m³

DASY4 Configuration:

Probe: ES3DV3 - SN3128; ConvF(4.75, 4.75, 4.75); Calibrated: 6/22/2009

Electronics: DAE4 Sn725; Calibrated: 6/15/2009

Sensor-Surface: 4mm (Mechanical Surface Detection)

Phantom: SAM 1267; Type: SAM; Serial: 1267

Measurement SW: DASY4, V4.7 Build 80; Postprocessing SW: SEMCAD, V1.8 Build 186

$d=15$ mm, $P_{in}=250$ mW/Zoom Scan (7x7x7) (7x7x7)/Cube 0: Measurement grid: $dx=5$ mm,
 $dy=5$ mm, $dz=5$ mm

Reference Value = 92.3V/m; Power Drift = -0.047 dB

Peak SAR (extrapolated) = 17.8 W/kg

SAR(1 g) = 9.98 mW/g; SAR(10 g) = 5.32 mW/g

Maximum value of SAR (measured) = 11.6 mW/g

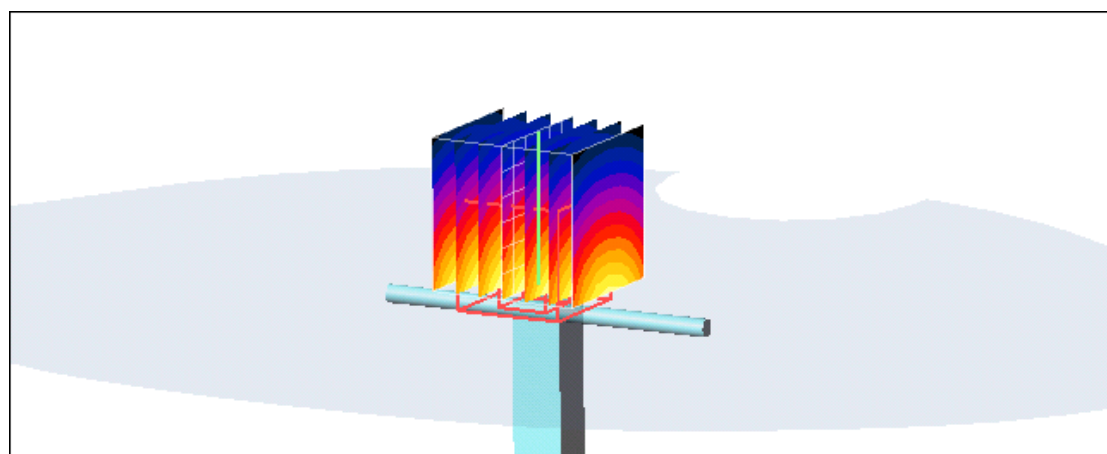
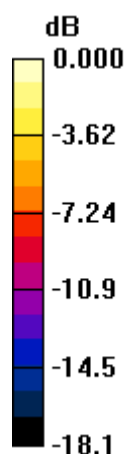

0 dB = 11.6 mW/g

GSM (1900MHz/Head)

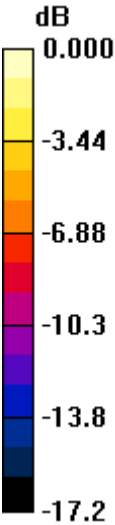
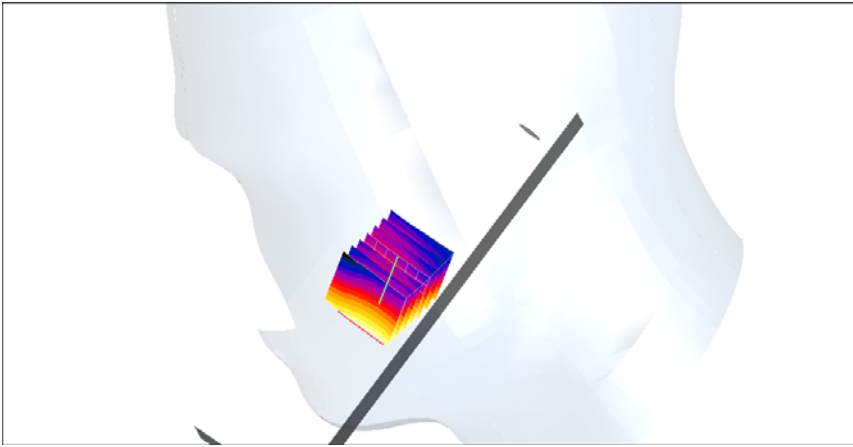
Right Side	Touch	1880 MHz
<p>Medium parameters used (interpolated): $f = 1880 \text{ MHz}$; $\sigma = 1.44 \text{ mho/m}$; $\epsilon_r = 39$; $\rho = 1000 \text{ kg/m}^3$</p> <p>DASY4 Configuration:</p> <p>Probe: ES3DV3 - SN3128; ConvF(4.75, 4.75, 4.75); Calibrated: 6/22/2009 Electronics: DAE4 Sn725; Calibrated: 6/15/2009 Sensor-Surface: 4mm (Mechanical Surface Detection) Phantom: SAM 1267; Type: SAM; Serial: 1267 Measurement SW: DASY4, V4.7 Build 80; Postprocessing SW: SEMCAD, V1.8 Build 186</p> <p>Touch position - Middle/Zoom Scan (7x7x7) (7x7x7)/Cube 0: Measurement grid: $dx=5\text{mm}$, $dy=5\text{mm}$, $dz=5\text{mm}$ Reference Value = 3.84 V/m; Power Drift = 0.06 dB Peak SAR (extrapolated) = 0.170 W/kg SAR(1 g) = 0.116 mW/g; SAR(10 g) = 0.075 mW/g Info: Interpolated medium parameters used for SAR evaluation. Maximum value of SAR (measured) = 0.124 mW/g</p>		
<div style="display: flex; align-items: center;"> <div style="margin-right: 20px;"> <p>dB</p>  </div> <div style="flex-grow: 1;">  </div> </div> <p style="text-align: center; margin-top: 20px;">0 dB = 0.124mW/g</p>		

Right Side

Tilt

1880 MHz

Medium parameters used (interpolated): $f = 1880$ MHz; $\sigma = 1.44$ mho/m; $\epsilon_r = 39$; $\rho = 1000$ kg/m³

DASY4 Configuration:

Probe: ES3DV3 - SN3128; ConvF(4.75, 4.75, 4.75); Calibrated: 6/22/2009

Electronics: DAE4 Sn725; Calibrated: 6/15/2009

Sensor-Surface: 4mm (Mechanical Surface Detection)

Phantom: SAM 1267; Type: SAM; Serial: 1267

Measurement SW: DASY4, V4.7 Build 80; Postprocessing SW: SEMCAD, V1.8 Build 186

Tilt position - Middle/Zoom Scan (7x7x7) (7x7x7)/Cube 0: Measurement grid: dx=5mm, dy=5mm, dz=5mm

Reference Value = 5.19 V/m; Power Drift = 0.023 dB

Peak SAR (extrapolated) = 0.064 W/kg

SAR(1 g) = 0.041 mW/g; SAR(10 g) = 0.025 mW/g

[Info: Interpolated medium parameters used for SAR evaluation.](#)

Maximum value of SAR (measured) = 0.046 mW/g

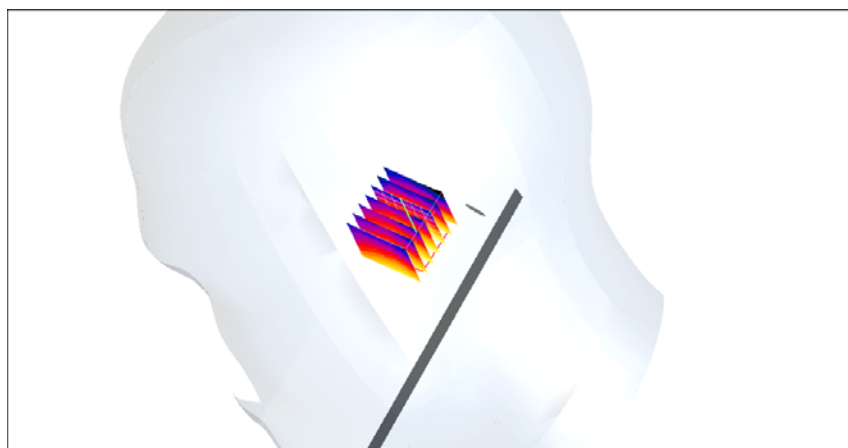
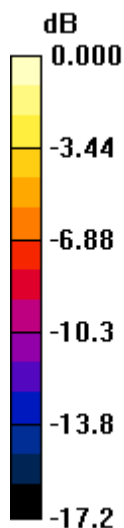

0 dB = 0.046 mW/g

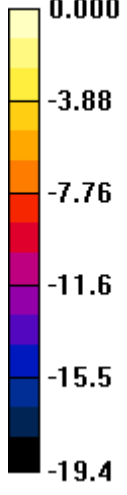
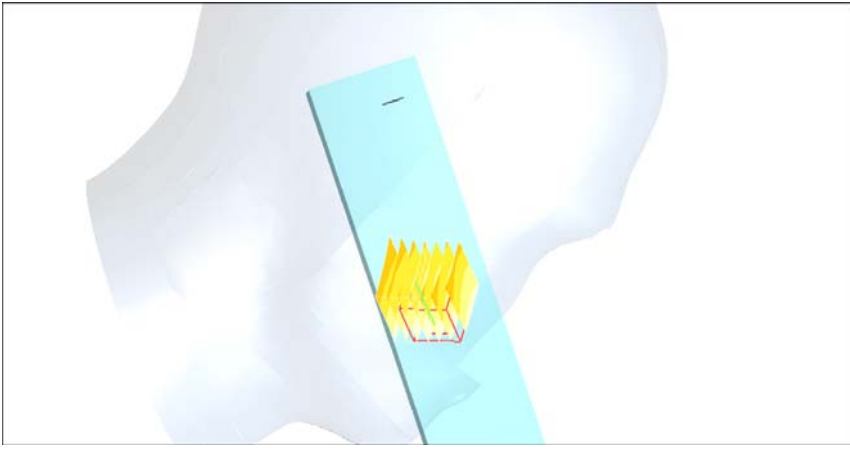
Left Side	Cheek	1880 MHz
Medium parameters used (interpolated): $f = 1880$ MHz; $\sigma = 1.44$ mho/m; $\epsilon_r = 39$; $\rho = 1000$ kg/m ³		
DASY4 Configuration: Probe:ES3DV3 - SN3128; ConvF(4.75, 4.75, 4.75); Calibrated: 6/22/2009 Electronics: DAE4 Sn725; Calibrated: 6/15/2009 Sensor-Surface: 4mm (Mechanical Surface Detection) Phantom: SAM 1267; Type: SAM; Serial: 1267 Measurement SW: DASY4, V4.7 Build 80; Postprocessing SW: SEMCAD, V1.8 Build 186		
<p>Touch position - Middle/Zoom Scan (7x7x7) (7x7x7)/Cube 0: Measurement grid: $dx=5$mm, $dy=5$mm, $dz=5$mm Reference Value = 1.37 V/m; Power Drift = 0.093 dB Peak SAR (extrapolated) = 0.188 W/kg SAR(1 g) = 0.129 mW/g; SAR(10 g) = 0.085 mW/g Info: Interpolated medium parameters used for SAR evaluation. Maximum value of SAR (measured) = 0.140 mW/g</p>		
<div style="display: flex; align-items: center;"> <div style="margin-right: 20px;"> <p>dB</p>  <p>0.000 -3.88 -7.76 -11.6 -15.5 -19.4</p> </div> <div style="flex-grow: 1;">  </div> </div> <p style="text-align: center; margin-top: 20px;">0 dB = 0.140 mW/g</p>		

Left Side

Tilt

1880 MHz

Medium parameters used (interpolated): $f = 1880\text{MHz}$; $\sigma = 1.44\text{ mho/m}$; $\epsilon_r = 39$; $\rho = 1000\text{ kg/m}^3$

DASY4 Configuration:

Probe: ES3DV3 - SN3128; ConvF(4.75, 4.75, 4.75); Calibrated: 6/22/2009

Electronics: DAE4 Sn725; Calibrated: 6/15/2009

Sensor-Surface: 4mm (Mechanical Surface Detection)

Phantom: SAM 1267; Type: SAM; Serial: 1267

Measurement SW: DASY4, V4.7 Build 80; Postprocessing SW: SEMCAD, V1.8 Build 186

Tilt position - Middle/Zoom Scan (7x7x7) (7x7x7)/Cube 0: Measurement grid: $dx=5\text{mm}$, $dy=5\text{mm}$, $dz=5\text{mm}$

Reference Value = 4.41 V/m; Power Drift = 0.114 dB

Peak SAR (extrapolated) = 0.081 W/kg

SAR(1 g) = 0.052 mW/g; SAR(10 g) = 0.031 mW/g

[Info: Interpolated medium parameters used for SAR evaluation.](#)

Maximum value of SAR (measured) = 0.056 mW/g

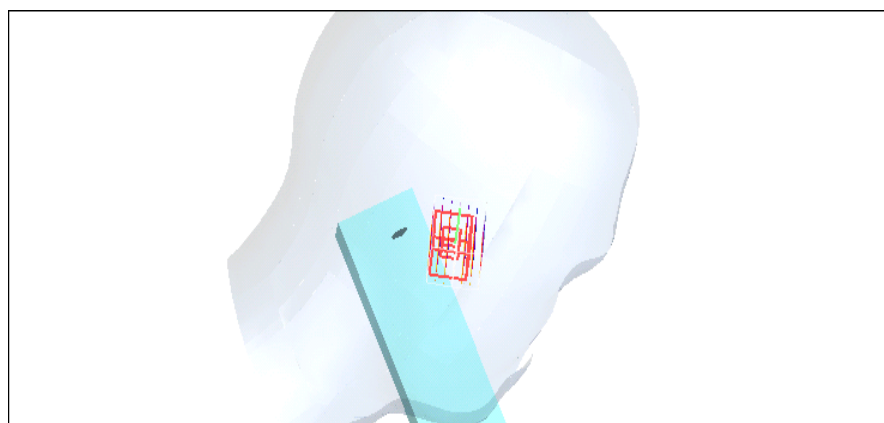
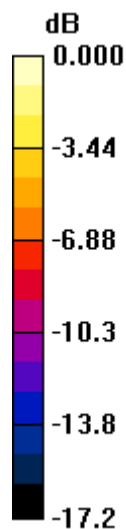

0 dB = 0.056mW/g

GSM (1900MHz/Body) with the headset

Towards ground

1880 MHz

Medium parameters used (interpolated): $f = 1880$ MHz; $\sigma = 1.49$ mho/m; $\epsilon_r = 54.6$; $\rho = 1000$ kg/m³

DASY4 Configuration:

Probe: ES3DV3 - SN3128; ConvF(4.4, 4.4, 4.4); Calibrated: 6/22/2009

Electronics: DAE4 Sn725; Calibrated: 6/15/2009

Sensor-Surface: 4mm (Mechanical Surface Detection)

Phantom: SAM 1267; Type: SAM; Serial: 1267

Measurement SW: DASY4, V4.7 Build 80; Postprocessing SW: SEMCAD, V1.8 Build 186

Towards ground/Zoom Scan (7x7x7)/Cube 0: Measurement grid: $dx=5$ mm, $dy=5$ mm, $dz=5$ mm

Reference Value = 5.46 V/m; Power Drift = -0.202 dB

Peak SAR (extrapolated) = 0.230 W/kg

SAR(1 g) = 0.156 mW/g; SAR(10 g) = 0.101 mW/g

Maximum value of SAR (measured) = 0.169 mW/g

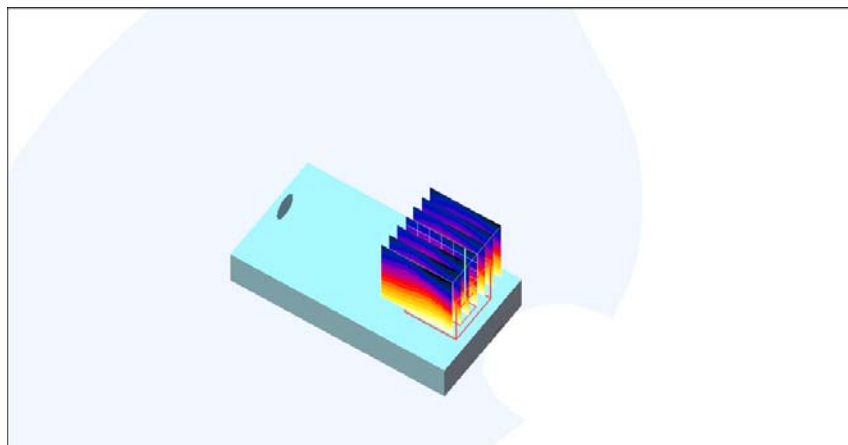
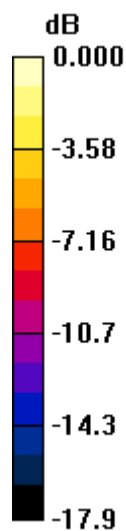

0 dB = 0.169 mW/g

Back ground

1880 MHz

Medium parameters used (interpolated): $f = 1880$ MHz; $\sigma = 1.49$ mho/m; $\epsilon_r = 54.6$; $\rho = 1000$ kg/m³

DASY4 Configuration:

Probe: ES3DV3 - SN3128; ConvF(4.4, 4.4, 4.4); Calibrated: 6/22/2009

Electronics: DAE4 Sn725; Calibrated: 6/15/2009

Sensor-Surface: 4mm (Mechanical Surface Detection)

Phantom: SAM 1267; Type: SAM; Serial: 1267

Measurement SW: DASY4, V4.7 Build 80; Postprocessing SW: SEMCAD, V1.8 Build 186

Towards Phatom/Zoom Scan (7x7x7)/Cube 0: Measurement grid: $dx=5$ mm, $dy=5$ mm, $dz=5$ mm

Reference Value = 7.77 V/m; Power Drift = -0.032 dB

Peak SAR (extrapolated) = 0.221 W/kg

SAR(1 g) = 0.138 mW/g; SAR(10 g) = 0.084 mW/g

Maximum value of SAR (measured) = 0.149 mW/g

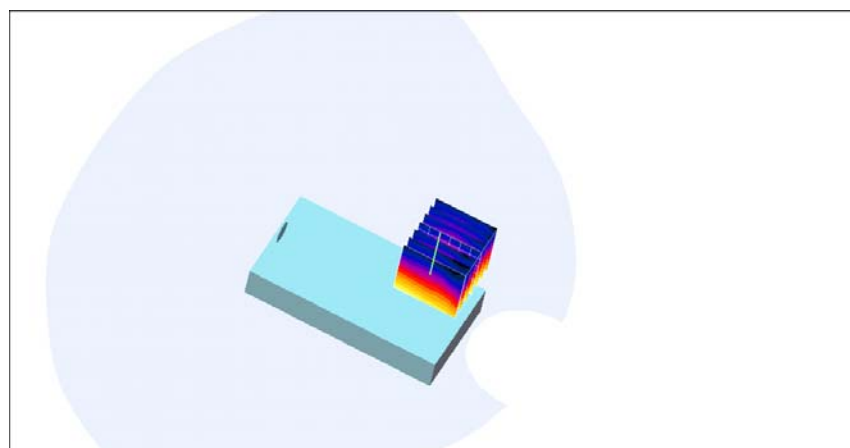
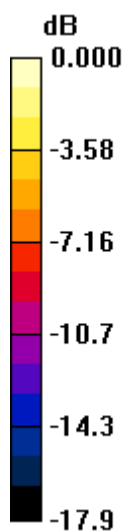

0 dB = 0.149mW/g

GPRS (1900MHz/Body) with the headset

Towards ground

1880 MHz

Medium parameters used (interpolated): $f = 1880$ MHz; $\sigma = 1.49$ mho/m; $\epsilon_r = 54.6$; $\rho = 1000$ kg/m³

DASY4 Configuration:

Probe: ES3DV3 - SN3128; ConvF(4.4, 4.4, 4.4); Calibrated: 6/22/2009

Electronics: DAE4 Sn725; Calibrated: 6/15/2009

Sensor-Surface: 4mm (Mechanical Surface Detection)

Phantom: SAM 1267; Type: SAM; Serial: 1267

Measurement SW: DASY4, V4.7 Build 80; Postprocessing SW: SEMCAD, V1.8 Build 186

Towards ground GPRS Mid/Zoom Scan (7x7x7)/Cube 0: Measurement grid: dx=5mm, dy=5mm, dz=5mm

Reference Value = 17.3 V/m; Power Drift = -0.220dB

Peak SAR (extrapolated) = 1.07 W/kg

SAR(1 g) = 0.660 mW/g; SAR(10 g) = 0.405 mW/g

Maximum value of SAR (measured) = 0.718 mW/g

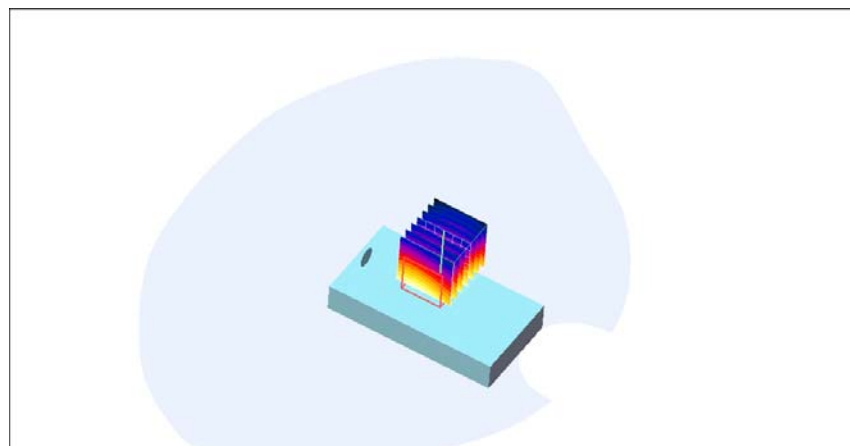
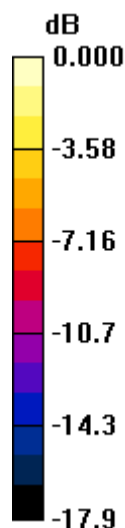

0 dB = 0.718 mW/g

Towards ground

1850.2 MHz

Medium parameters used (interpolated): $f = 1850.2$ MHz; $\sigma = 1.46$ mho/m; $\epsilon_r = 53.8$; $\rho = 1000$ kg/m³

DASY4 Configuration:

Probe: ES3DV3 - SN3128; ConvF(4.4, 4.4, 4.4); Calibrated: 6/22/2009

Electronics: DAE4 Sn725; Calibrated: 6/15/2009

Sensor-Surface: 4mm (Mechanical Surface Detection)

Phantom: SAM 1267; Type: SAM; Serial: 1267

Measurement SW: DASY4, V4.7 Build 80; Postprocessing SW: SEMCAD, V1.8 Build 186

Towards ground GPRS LOW/Zoom Scan (7x7x7)/Cube 0: Measurement grid: dx=5mm, dy=5mm, dz=5mm

Reference Value = 15.7 V/m; Power Drift = -0.210 dB

Peak SAR (extrapolated) = 1.33 W/kg

SAR(1 g) = 0.828 mW/g; SAR(10 g) = 0.502 mW/g

[Info: Interpolated medium parameters used for SAR evaluation.](#)

Maximum value of SAR (measured) = 0.897 mW/g

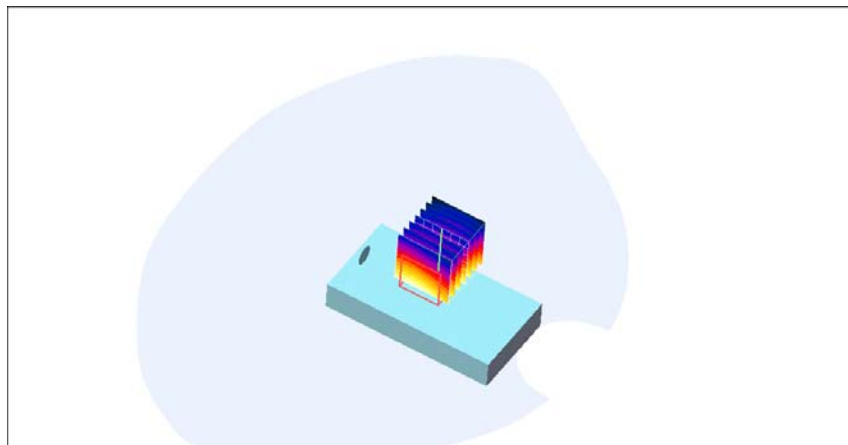
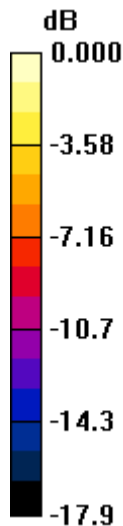

0 dB = 0.897 mW/g

Towards ground

1909.8 MHz

Medium parameters used (interpolated): $f = 1909.8$ MHz; $\sigma = 1.52$ mho/m; $\epsilon_r = 54.6$; $\rho = 1000$ kg/m³

DASY4 Configuration:

Probe: ES3DV3 - SN3128; ConvF(4.4, 4.4, 4.4); Calibrated: 6/22/2009

Electronics: DAE4 Sn725; Calibrated: 6/15/2009

Sensor-Surface: 4mm (Mechanical Surface Detection)

Phantom: SAM 1267; Type: SAM; Serial: 1267

Measurement SW: DASY4, V4.7 Build 80; Postprocessing SW: SEMCAD, V1.8 Build 186

Towards ground GPRS HIGH/Zoom Scan (7x7x7)/Cube 0: Measurement grid: dx=5mm, dy=5mm, dz=5mm

Reference Value = 16.3 V/m; Power Drift = -0.106 dB

Peak SAR (extrapolated) = 1.52 W/kg

SAR(1 g) = 0.940 mW/g; SAR(10 g) = 0.564 mW/g

Maximum value of SAR (measured) = 1.01 mW/g

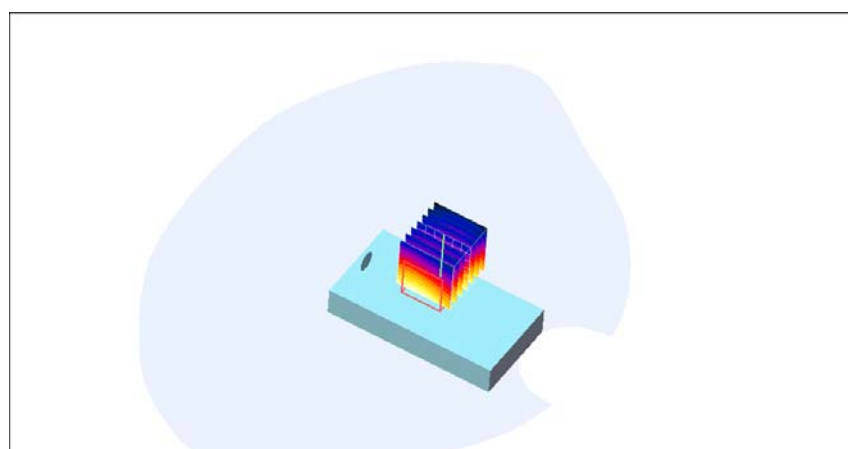
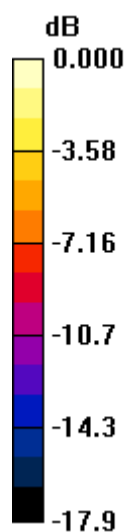

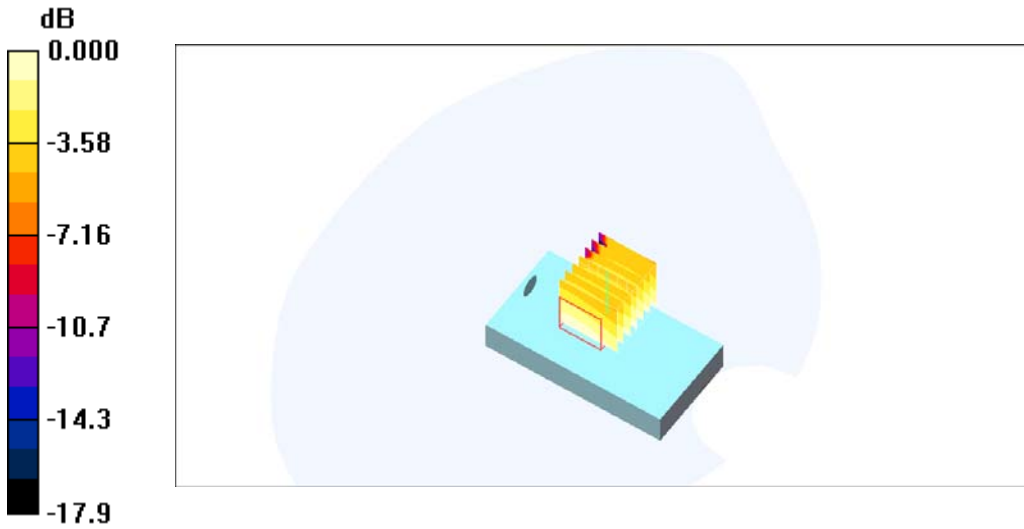

0 dB = 1.01 mW/g

EDGE (1900MHz/Body) with the headset

Towards ground	1880 MHz
Medium parameters used (interpolated): $f = 1880$ MHz; $\sigma = 1.49$ mho/m; $\epsilon_r = 54.6$; $\rho = 1000$ kg/m ³	
DASY4 Configuration:	
Probe: ES3DV3 - SN3128; ConvF(4.4, 4.4, 4.4); Calibrated: 6/22/2009	
Electronics: DAE4 Sn725; Calibrated: 6/15/2009	
Sensor-Surface: 4mm (Mechanical Surface Detection)	
Phantom: SAM 1267; Type: SAM; Serial: 1267	
Measurement SW: DASY4, V4.7 Build 80; Postprocessing SW: SEMCAD, V1.8 Build 186	
Towards ground EDGE/Zoom Scan (7x7x7)/Cube 0: Measurement grid: dx=5mm, dy=5mm, dz=5mm	
Reference Value = 15.3 V/m; Power Drift = -0.033 dB	
Peak SAR (extrapolated) = 0.921 W/kg	
SAR(1 g) = 0.514 mW/g; SAR(10 g) = 0.321 mW/g	
Maximum value of SAR (measured) = 0.559 mW/g	
 <p>0 dB = 0.559mW/g</p>	

7.8 Pictures of the device under test

the device under test

 A black mobile phone is shown from the front, lying flat on a light-colored wooden surface. A metal ruler is placed horizontally above the phone, showing markings from 20 to 35 centimeters. The phone's screen is dark and reflects light.	 A black mobile phone is shown from the back, lying flat on a light-colored wooden surface. A metal ruler is placed horizontally above the phone, showing markings from 20 to 35 centimeters. A white label with the text 'FCC ID: UPMW310001' is visible on the left side of the back cover.
<p>Front view of the device</p>	<p>back view of the device</p>
 A black mobile phone is shown from the front, lying flat on a light-colored wooden surface. A metal ruler is placed horizontally above the phone, showing markings from 17 to 37 centimeters. The phone's keypad and screen are visible.	
<p>Front view of the device</p>	

7.9 Test Positions for the Device under test



Cheek position, left side

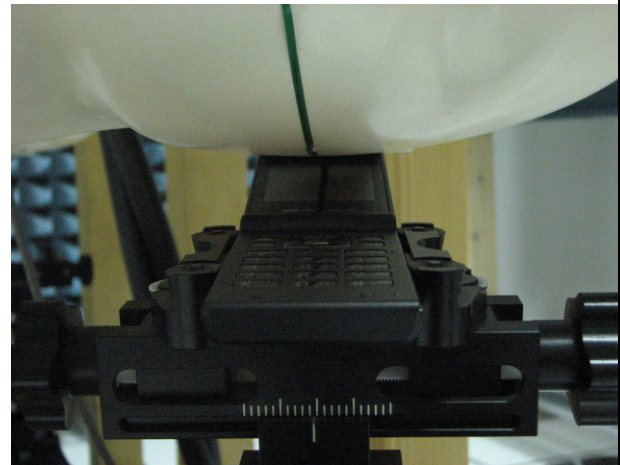

Tilt position, left side

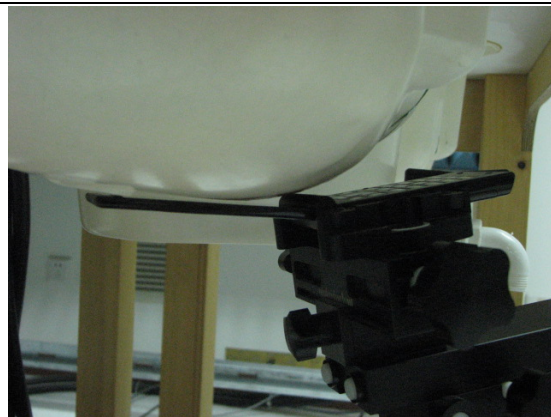

Cheek position, Right side

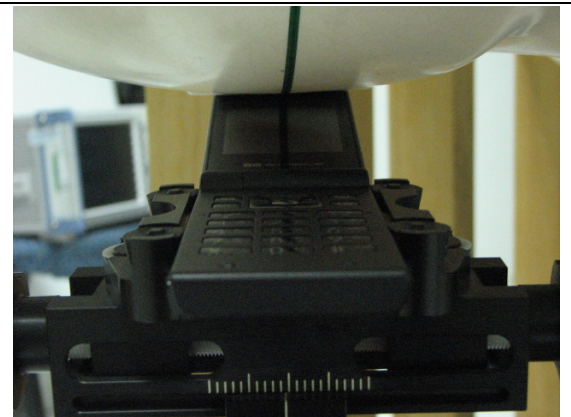

Tilt position, Right side



Body position with the headset



The width of the spacer

Test Positions for the Device under test

7.10 Picture to demonstrate the required liquid depth

the liquid depth in the used SAM phantoms



Liquid depth for SAR Measurement

7.11 Certificate of conformity

Calibration Laboratory of
Schmid & Partner
Engineering AG
 Zeughausstrasse 43, 8004 Zurich, Switzerland



S Schweizerischer Kalibrierdienst
C Service suisse d'étalonnage
S Servizio svizzero di taratura
S Swiss Calibration Service

Accredited by the Swiss Accreditation Service (SAS)
 The Swiss Accreditation Service is one of the signatories to the EA
 Multilateral Agreement for the recognition of calibration certificates

Accreditation No.: **SCS 108**

Client **SRMC (PTT)**

Certificate No: **DAE4-725_Jun09**

CALIBRATION CERTIFICATE

Object **DAE4 - SD 000 D04 BJ - SN: 725**

Calibration procedure(s) **QA CAL-06.v12
 Calibration procedure for the data acquisition electronics (DAE)**

Calibration date: **June 15, 2009**

Condition of the calibrated item **In Tolerance**

This calibration certificate documents the traceability to national standards, which realize the physical units of measurements (SI).
 The measurements and the uncertainties with confidence probability are given on the following pages and are part of the certificate.

All calibrations have been conducted in the closed laboratory facility: environment temperature (22 ± 3)°C and humidity < 70%.

Calibration Equipment used (M&TE critical for calibration)

Primary Standards	ID #	Cal Date (Certificate No.)	Scheduled Calibration
Fluke Process Calibrator Type 702	SN: 6295803	30-Sep-08 (No: 7673)	Sep-09
Keithley Multimeter Type 2001	SN: 0810278	30-Sep-08 (No: 7670)	Sep-09
Secondary Standards	ID #	Check Date (in house)	Scheduled Check
Calibrator Box V1.1	SE UMS 006 AB 1004	05-Jun-09 (in house check)	In house check: Jun-10

	Name	Function	Signature
Calibrated by:	Daniel Hess	Technician	<i>D. Hess</i>
Approved by:	Fin Bomholt	R&D Director	<i>F. Bomholt</i>

Issued: June 18, 2009

This calibration certificate shall not be reproduced except in full without written approval of the laboratory.

Calibration Laboratory of
Schmid & Partner
Engineering AG
Zeughausstrasse 43, 8004 Zurich, Switzerland



S Schweizerischer Kalibrierdienst
C Service suisse d'étalonnage
S Servizio svizzero di taratura
S Swiss Calibration Service

Accredited by the Swiss Accreditation Service (SAS)
The Swiss Accreditation Service is one of the signatories to the EA
Multilateral Agreement for the recognition of calibration certificates

Accreditation No.: SCS 108

Glossary

DAE data acquisition electronics
Connector angle information used in DASY system to align probe sensor X to the robot coordinate system.

Methods Applied and Interpretation of Parameters

- *DC Voltage Measurement*: Calibration Factor assessed for use in DASY system by comparison with a calibrated instrument traceable to national standards. The figure given corresponds to the full scale range of the voltmeter in the respective range.
- *Connector angle*: The angle of the connector is assessed measuring the angle mechanically by a tool inserted. Uncertainty is not required.
- The following parameters as documented in the Appendix contain technical information as a result from the performance test and require no uncertainty.
 - *DC Voltage Measurement Linearity*: Verification of the Linearity at +10% and -10% of the nominal calibration voltage. Influence of offset voltage is included in this measurement.
 - *Common mode sensitivity*: Influence of a positive or negative common mode voltage on the differential measurement.
 - *Channel separation*: Influence of a voltage on the neighbor channels not subject to an input voltage.
 - *AD Converter Values with inputs shorted*: Values on the internal AD converter corresponding to zero input voltage
 - *Input Offset Measurement*: Output voltage and statistical results over a large number of zero voltage measurements.
 - *Input Offset Current*: Typical value for information; Maximum channel input offset current, not considering the input resistance.
 - *Input resistance*: DAE input resistance at the connector, during internal auto-zeroing and during measurement.
 - *Low Battery Alarm Voltage*: Typical value for information. Below this voltage, a battery alarm signal is generated.
 - *Power consumption*: Typical value for information. Supply currents in various operating modes.

DC Voltage Measurement

A/D - Converter Resolution nominal

High Range: 1LSB = 6.1 μ V, full range = -100...+300 mV
Low Range: 1LSB = 61nV, full range = -1.....+3mV

DASY measurement parameters: Auto Zero Time: 3 sec; Measuring time: 3 sec

Calibration Factors	X	Y	Z
High Range	404.179 \pm 0.1% (k=2)	404.931 \pm 0.1% (k=2)	404.498 \pm 0.1% (k=2)
Low Range	3.90830 \pm 0.7% (k=2)	3.98545 \pm 0.7% (k=2)	3.98641 \pm 0.7% (k=2)

Connector Angle

Connector Angle to be used in DASY system	236 $^{\circ}$ \pm 1 $^{\circ}$
---	-----------------------------------

Appendix

1. DC Voltage Linearity

High Range	Input (μV)	Reading (μV)	Error (%)
Channel X + Input	200000	199999.9	0.00
Channel X + Input	20000	20008.43	0.04
Channel X - Input	20000	-19998.02	-0.01
Channel Y + Input	200000	200000	0.00
Channel Y + Input	20000	20006.27	0.03
Channel Y - Input	20000	-20001.56	0.01
Channel Z + Input	200000	200000	0.00
Channel Z + Input	20000	20005.16	0.03
Channel Z - Input	20000	-20002.80	0.01

Low Range	Input (μV)	Reading (μV)	Error (%)
Channel X + Input	2000	2000	0.00
Channel X + Input	200	199.84	-0.08
Channel X - Input	200	-199.88	-0.06
Channel Y + Input	2000	1999.9	0.00
Channel Y + Input	200	199.32	-0.34
Channel Y - Input	200	-200.12	0.06
Channel Z + Input	2000	2000.1	0.00
Channel Z + Input	200	199.14	-0.43
Channel Z - Input	200	-201.59	0.80

2. Common mode sensitivity

DASY measurement parameters: Auto Zero Time: 3 sec; Measuring time: 3 sec

	Common mode Input Voltage (mV)	High Range Average Reading (μV)	Low Range Average Reading (μV)
Channel X	200	10.11	9.02
	- 200	-7.46	-8.62
Channel Y	200	-10.61	-10.93
	- 200	10.67	9.94
Channel Z	200	-3.58	-3.89
	- 200	2.46	2.29

3. Channel separation

DASY measurement parameters: Auto Zero Time: 3 sec; Measuring time: 3 sec

	Input Voltage (mV)	Channel X (μV)	Channel Y (μV)	Channel Z (μV)
Channel X	200	-	2.29	0.66
Channel Y	200	1.63	-	4.98
Channel Z	200	-0.38	-0.06	-

4. AD-Converter Values with inputs shorted

DASY measurement parameters: Auto Zero Time: 3 sec; Measuring time: 3 sec

	High Range (LSB)	Low Range (LSB)
Channel X	16213	14897
Channel Y	16224	15636
Channel Z	16106	16320

5. Input Offset Measurement

DASY measurement parameters: Auto Zero Time: 3 sec; Measuring time: 3 sec

Input 10M Ω

	Average (μ V)	min. Offset (μ V)	max. Offset (μ V)	Std. Deviation (μ V)
Channel X	-0.29	-1.24	1.43	0.33
Channel Y	-2.73	-3.64	-1.66	0.39
Channel Z	-1.10	-2.27	-0.24	0.35

6. Input Offset Current

Nominal Input circuitry offset current on all channels: <25fA

7. Input Resistance

	Zeroing (MOhm)	Measuring (MOhm)
Channel X	0.2001	200.5
Channel Y	0.2000	201.5
Channel Z	0.2000	200.0

8. Low Battery Alarm Voltage (verified during pre test)

Typical values	Alarm Level (VDC)
Supply (+ Vcc)	+7.9
Supply (- Vcc)	-7.6

9. Power Consumption (verified during pre test)

Typical values	Switched off (mA)	Stand by (mA)	Transmitting (mA)
Supply (+ Vcc)	+0.0	+6	+14
Supply (- Vcc)	-0.01	-8	-9

Calibration Laboratory of
 Schmid & Partner
 Engineering AG
 Zeughausstrasse 43, 8004 Zurich, Switzerland



S Schweizerischer Kalibrierdienst
C Service suisse d'étalonnage
S Servizio svizzero di taratura
S Swiss Calibration Service

Accredited by the Swiss Accreditation Service (SAS)
 The Swiss Accreditation Service is one of the signatories to the EA
 Multilateral Agreement for the recognition of calibration certificates

Accreditation No.: **SCS 108**

Client **SRMC (PTT)**

Certificate No: **ES3-3128_Jun09**

CALIBRATION CERTIFICATE

Object: **ES3DV3 - SN:3128**

Calibration procedure(s): **QA CAL-01.v6 and QA CAL-23.v3
 Calibration procedure for dosimetric E-field probes**

Calibration date: **June 22, 2009**

Condition of the calibrated item: **In Tolerance**

This calibration certificate documents the traceability to national standards, which realize the physical units of measurements (SI).
 The measurements and the uncertainties with confidence probability are given on the following pages and are part of the certificate.

All calibrations have been conducted in the closed laboratory facility: environment temperature (22 ± 3)°C and humidity < 70%.

Calibration Equipment used (M&TE critical for calibration)

Primary Standards	ID #	Cal Date (Certificate No.)	Scheduled Calibration
Power meter E4419B	GB41293874	1-Apr-09 (No. 217-01030)	Apr-10
Power sensor E4412A	MY41495277	1-Apr-09 (No. 217-01030)	Apr-10
Power sensor E4412A	MY41498087	1-Apr-09 (No. 217-01030)	Apr-10
Reference 3 dB Attenuator	SN: S5054 (3c)	31-Mar-09 (No. 217-01026)	Mar-10
Reference 20 dB Attenuator	SN: S5086 (20b)	31-Mar-09 (No. 217-01028)	Mar-10
Reference 30 dB Attenuator	SN: S5129 (30b)	31-Mar-09 (No. 217-01027)	Mar-10
Reference Probe ES3DV2	SN: 3013	2-Jan-09 (No. ES3-3013_Jan09)	Jan-10
DAE4	SN: 660	9-Sep-08 (No. DAE4-660_Sep08)	Sep-09
Secondary Standards	ID #	Check Date (in house)	Scheduled Check
RF generator HP 8848C	US3842U01700	4-Aug-99 (in house check Oct-07)	In house check: Oct-09
Network Analyzer HP 8753E	US37390585	18-Oct-01 (in house check Oct-08)	In house check: Oct-09

Calibrated by:	Name	Function	Signature
	Jeton Kastrati	Laboratory Technician	
Approved by:	Name	Function	Signature
	Katja Pokovic	Technical Manager	

Issued: June 22, 2009

This calibration certificate shall not be reproduced except in full without written approval of the laboratory.

Calibration Laboratory of
Schmid & Partner
Engineering AG
Zeughausstrasse 43, 8004 Zurich, Switzerland



S Schweizerischer Kalibrierdienst
C Service suisse d'étalonnage
S Servizio svizzero di taratura
S Swiss Calibration Service

Accredited by the Swiss Accreditation Service (SAS)
The Swiss Accreditation Service is one of the signatories to the EA
Multilateral Agreement for the recognition of calibration certificates

Accreditation No.: SCS 108

Glossary:

TSL	tissue simulating liquid
NORM _{x,y,z}	sensitivity in free space
ConvF	sensitivity in TSL / NORM _{x,y,z}
DCP	diode compression point
Polarization φ	φ rotation around probe axis
Polarization ϑ	ϑ rotation around an axis that is in the plane normal to probe axis (at measurement center), i.e., $\vartheta = 0$ is normal to probe axis

Calibration is Performed According to the Following Standards:

- IEEE Std 1528-2003, "IEEE Recommended Practice for Determining the Peak Spatial-Averaged Specific Absorption Rate (SAR) in the Human Head from Wireless Communications Devices: Measurement Techniques", December 2003
- IEC 62209-1, "Procedure to measure the Specific Absorption Rate (SAR) for hand-held devices used in close proximity to the ear (frequency range of 300 MHz to 3 GHz)", February 2005

Methods Applied and Interpretation of Parameters:

- NORM_{x,y,z}**: Assessed for E-field polarization $\vartheta = 0$ ($f \leq 900$ MHz in TEM-cell; $f > 1800$ MHz: R22 waveguide). NORM_{x,y,z} are only intermediate values, i.e., the uncertainties of NORM_{x,y,z} does not effect the E²-field uncertainty inside TSL (see below ConvF).
- NORM(f)_{x,y,z}** = NORM_{x,y,z} * frequency_response (see Frequency Response Chart). This linearization is implemented in DASY4 software versions later than 4.2. The uncertainty of the frequency response is included in the stated uncertainty of ConvF.
- DCP_{x,y,z}**: DCP are numerical linearization parameters assessed based on the data of power sweep (no uncertainty required). DCP does not depend on frequency nor media.
- ConvF and Boundary Effect Parameters**: Assessed in flat phantom using E-field (or Temperature Transfer Standard for $f \leq 800$ MHz) and inside waveguide using analytical field distributions based on power measurements for $f > 800$ MHz. The same setups are used for assessment of the parameters applied for boundary compensation (alpha, depth) of which typical uncertainty values are given. These parameters are used in DASY4 software to improve probe accuracy close to the boundary. The sensitivity in TSL corresponds to NORM_{x,y,z} * ConvF whereby the uncertainty corresponds to that given for ConvF. A frequency dependent ConvF is used in DASY version 4.4 and higher which allows extending the validity from ± 50 MHz to ± 100 MHz.
- Spherical isotropy (3D deviation from isotropy)**: in a field of low gradients realized using a flat phantom exposed by a patch antenna.
- Sensor Offset**: The sensor offset corresponds to the offset of virtual measurement center from the probe tip (on probe axis). No tolerance required.

ES3DV3 SN:3128

June 22, 2009

Probe ES3DV3

SN:3128

Manufactured:	July 11, 2006
Last calibrated:	January 24, 2007
Recalibrated:	June 22, 2009

Calibrated for DASYS Systems

(Note: non-compatible with DASYS2 system!)

ES3DV3 SN:3128

June 22, 2009

DASY - Parameters of Probe: ES3DV3 SN:3128

Sensitivity in Free Space ^A			Diode Compression ^B	
NormX	1.26 ± 10.1%	μV/(V/m) ²	DCP X	92 mV
NormY	1.36 ± 10.1%	μV/(V/m) ²	DCP Y	94 mV
NormZ	1.32 ± 10.1%	μV/(V/m) ²	DCP Z	94 mV

Sensitivity in Tissue Simulating Liquid (Conversion Factors)

Please see Page 8.

Boundary Effect

TSL	900 MHz	Typical SAR gradient: 5 % per mm		
	Sensor Center to Phantom Surface Distance		3.0 mm	4.0 mm
	SAR _{be} [%] Without Correction Algorithm		9.7	5.5
	SAR _{be} [%] With Correction Algorithm		0.7	0.5

TSL	1750 MHz	Typical SAR gradient: 10 % per mm		
	Sensor Center to Phantom Surface Distance		3.0 mm	4.0 mm
	SAR _{be} [%] Without Correction Algorithm		8.9	5.2
	SAR _{be} [%] With Correction Algorithm		0.8	0.6

Sensor Offset

Probe Tip to Sensor Center **2.0 mm**

The reported uncertainty of measurement is stated as the standard uncertainty of measurement multiplied by the coverage factor k=2, which for a normal distribution corresponds to a coverage probability of approximately 95%.

^A The uncertainties of NormX,Y,Z do not affect the E²-field uncertainty inside TSL (see Page 8).

^B Numerical linearization parameter: uncertainty not required.

ES3DV3 SN:3128

June 22, 2009

Frequency Response of E-Field

(TEM-Cell:ifi110 EXX, Waveguide: R22)

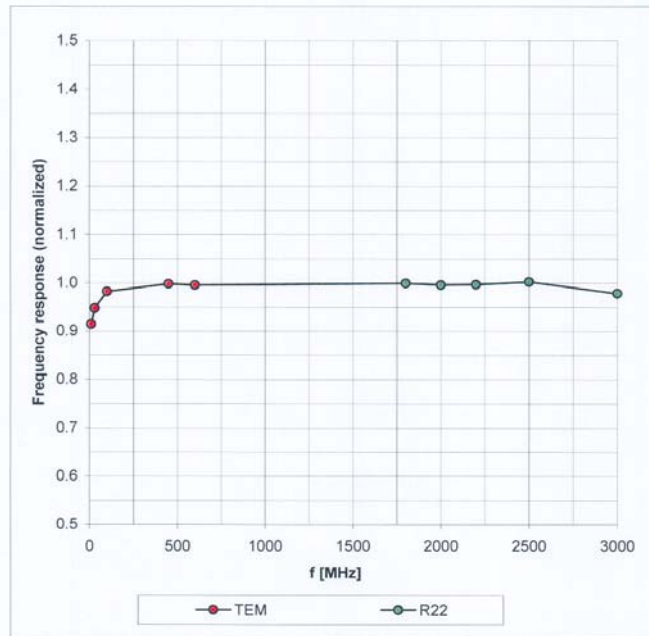

Uncertainty of Frequency Response of E-field: $\pm 6.3\%$ (k=2)

ES3DV3 SN:3128

June 22, 2009

Receiving Pattern (ϕ), $\vartheta = 0^\circ$

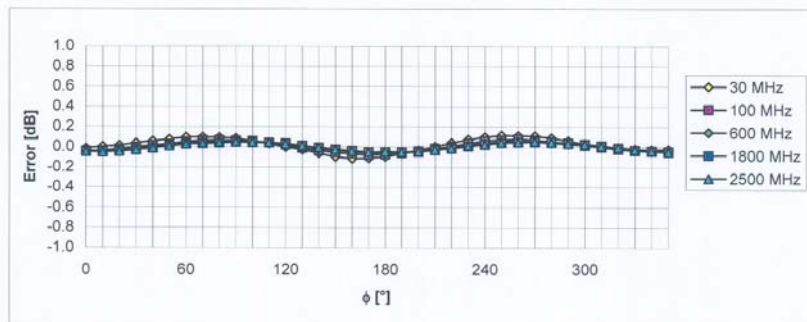
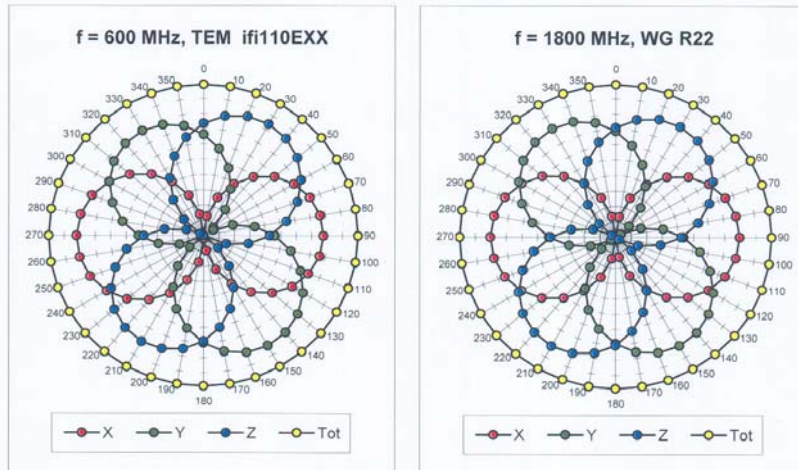

Uncertainty of Axial Isotropy Assessment: $\pm 0.5\%$ ($k=2$)

ES3DV3 SN:3128

June 22, 2009

Dynamic Range $f(\text{SAR}_{\text{head}})$ (Waveguide R22, $f = 1800$ MHz)

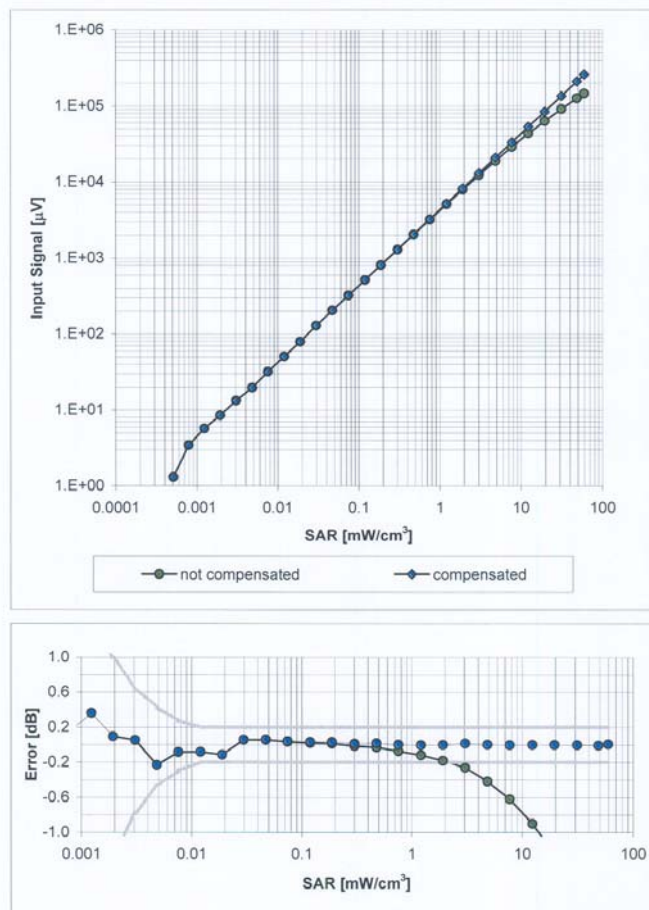

Uncertainty of Linearity Assessment: $\pm 0.6\%$ ($k=2$)

ES3DV3 SN:3128

June 22, 2009

Conversion Factor Assessment

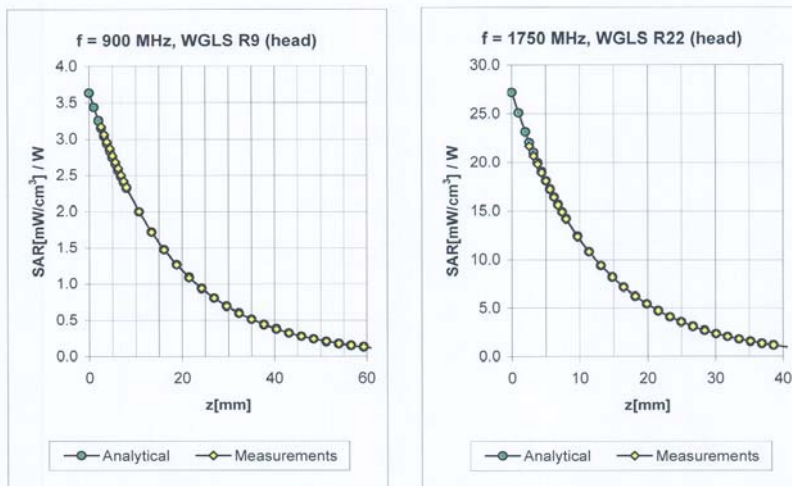

f [MHz]	Validity [MHz] ^c	TSL	Permittivity	Conductivity	Alpha	Depth	ConvF Uncertainty
835	± 50 / ± 100	Head	41.5 ± 5%	0.90 ± 5%	0.94	1.06	5.68 ± 11.0% (k=2)
900	± 50 / ± 100	Head	41.5 ± 5%	0.97 ± 5%	0.83	1.11	5.52 ± 11.0% (k=2)
1750	± 50 / ± 100	Head	40.1 ± 5%	1.37 ± 5%	0.52	1.43	4.93 ± 11.0% (k=2)
1900	± 50 / ± 100	Head	40.0 ± 5%	1.40 ± 5%	0.52	1.46	4.75 ± 11.0% (k=2)
2000	± 50 / ± 100	Head	40.0 ± 5%	1.40 ± 5%	0.42	1.60	4.69 ± 11.0% (k=2)
835	± 50 / ± 100	Body	55.2 ± 5%	0.97 ± 5%	0.74	1.21	5.72 ± 11.0% (k=2)
900	± 50 / ± 100	Body	55.0 ± 5%	1.05 ± 5%	0.79	1.15	5.58 ± 11.0% (k=2)
1750	± 50 / ± 100	Body	53.4 ± 5%	1.49 ± 5%	0.37	1.93	4.60 ± 11.0% (k=2)
1900	± 50 / ± 100	Body	53.3 ± 5%	1.52 ± 5%	0.36	2.06	4.40 ± 11.0% (k=2)
2000	± 50 / ± 100	Body	53.3 ± 5%	1.52 ± 5%	0.38	2.04	4.46 ± 11.0% (k=2)

^c The validity of ± 100 MHz only applies for DASY v4.4 and higher (see Page 2). The uncertainty is the RSS of the ConvF uncertainty at calibration frequency and the uncertainty for the indicated frequency band.

ES3DV3 SN:3128

June 22, 2009

Deviation from Isotropy in HSL

Error (ϕ, ϑ), $f = 900$ MHz

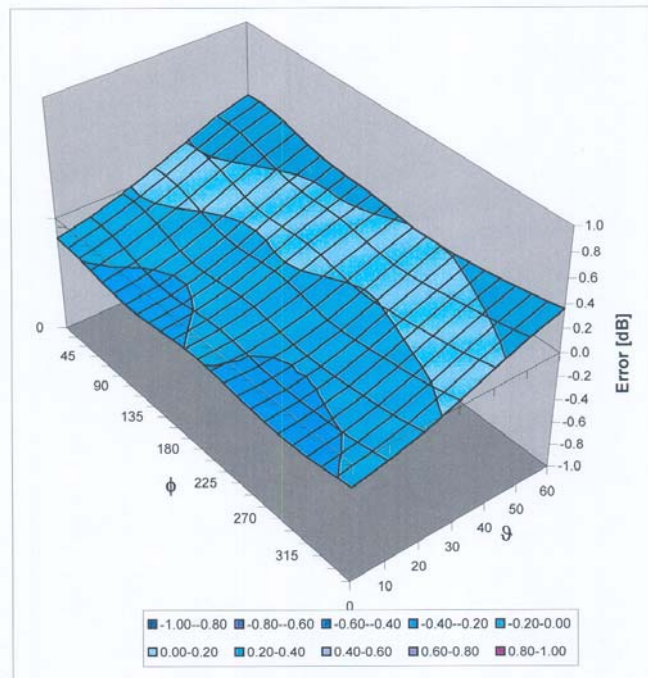

Uncertainty of Spherical Isotropy Assessment: $\pm 2.6\%$ ($k=2$)

Schmid & Partner Engineering AG

s p e a g

Zeughausstrasse 43, 8004 Zurich, Switzerland
 Phone +41 1 245 9700, Fax +41 1 245 9779
 info@speag.com, http://www.speag.com

Certificate of conformity / First Article Inspection

Item	SAM Twin Phantom V4.0
Type No	QD 000 P40 C
Series No	TP-1150 and higher
Manufacturer / Origin	Untersee Composites Hauptstr. 69 CH-8559 Fruthwilen Switzerland

Tests

The series production process used allows the limitation to test of first articles.
 Complete tests were made on the pre-series Type No. QD 000 P40 AA, Serial No. TP-1001 and on the series first article Type No. QD 000 P40 BA, Serial No. TP-1006. Certain parameters have been retested using further series units (called samples).

Test	Requirement	Details	Units tested
Shape	Compliance with the geometry according to the CAD model.	IT'IS CAD File (*)	First article, Samples
Material thickness	Compliant with the requirements according to the standards	2mm +/- 0.2mm in specific areas; 6mm +/- 0.2mm at ERP	First article, Samples
Material parameters	Dielectric parameters for required frequencies	200 MHz – 3 GHz Relative permittivity < 5 Loss tangent < 0.05.	Material sample TP 104-5
Material resistivity	The material has been tested to be compatible with the liquids defined in the standards if handled and cleaned according to the instructions	DEGMBE based simulating liquids	Pre-series, First article, Samples

Standards

- [1] CENELEC EN 50361
- [2] IEEE Std 1528-200x Draft CD 1.1 (Dec 02)
- [1] and [3].

Conformity

Based on the sample tests above, we certify that this item is in compliance with the uncertainty requirements of SAR measurements specified in standard [1] and draft standards [2] and [3].

Date 7.8.2003

Signature / Stamp  Schmid & Partner Engineering AG 

Zeughausstrasse 43, CH-8004 Zurich
Tel. +41 1 245 97 00, Fax +41 1 245 97 79